



BHARAT HEAVY ELECTRICALS LIMITED

BAP – Ranipet, 632406

M M – PURCHASE Department (FGD)

NIT

BHEL Ranipet Enq for.: Trolley

Date: 18-09-2021

Sub: Requirement for “Supply or Trolley as per Scope” for NTPC-Dadri by BHEL-Ranipet.

Scope of supply: As subjected above in confirmation with Quality plan. The scope consists of:

Enq sl no	BHEL Material code	Description	Unit	Qty	Delivery by
1	RFW113640001	Supply of Manual operated wheel mounted Platform (seamless) trolley (chequered plate 8'x6' platform) of 4T load carry capacity, as per drg 4-FW-790-01396 REVOO AND SPEC: FGD:PTY, REV:00	Set	1	15-10-2021

Destination: BHEL Site, NTPC-Dadri

Delivery required date: As per above scope of supply or within 1 month from the date of manufacturing clearance, whichever is later. Bidder to quote the best possible delivery from the date of manufacturing clearance. Abnormal quoted delivery, liable for rejection of offer.

Technical requirement

- (a). **Manufacturing: Document Submission-**Drawing, Data sheet and quality plan shall be submitted upon ordering for approval by BHEL. **Manufacturing clearance** will be provided upon approval of drawing with data sheet and QAP. Manufacturing shall be as per attached technical specification in the bid, Approved drawing, Quality plan and Data sheet. **Inspection:** as per Cl (b) below stated. **Dispatch Clearance:** Upon submission of inspection reports along with test certificates in original and Packing list dispatch clearance will be provided by BHEL.
- (b). **Inspection:** Inspection (call to be raise by supplier at BHEL CQIR portal) before despatch at supplier's works (as per Quality terms and Quality plan) by BHEL/ authorised agency (TPI-Third Party Inspection) for indigenous supplies at BHEL cost. Inspection includes for painting and packing also, as applicable. All the Test and inspection reports shall be sent to BHEL-Ranipet for review and dispatch clearance. Packing list and weighment details shall be sent for release of GMS by Engineering-BAP. Base on release of GMS, CoC No shall be issued by QC-BHEL. On receipt of CoC, and packing list, request letter from commercial-BAP to be submitted to QC-BHEL for issue of MDCC.
- (c). **Packing requirement:** Packing shall be waterproof and as per tech spec. All item shall be packed as per technical spec. and the material code with description & Supplier name shall be marked on the packing.
- (d). **Documents:** Accepted IR copy along with relevant test certificates (in original) before despatch to be given to BHEL. This is required for Dispatch clearance.
- (e). **Reverse Auction** shall be conducted, overall package wise L1 shall be taken for Ordering.
- (f). **Delivery Location:** FOR destination (BHEL Site, NTPC-Dadri)



BHARAT HEAVY ELECTRICALS LIMITED

BAP – Ranipet, 632406

M M – PURCHASE Department (FGD)

Note:

1. Quote shall be in INR only
2. Relevant documents/formats are attached in Additional scope of GeM bid.
3. Quoted rate shall be inclusive of GST, as per GeM terms and condition.
4. Non Submission of any of required documents as listed below, attracts for offer rejection.
5. Package wise evaluation methodology shall be adopted
6. Participation shall be treated as participant has accepted all the terms and conditions (technical and commercial) of tender.

List of documents to be attached (signed stamped copy):

1. NIT and GeM bid copy
2. Tech spec filled in along with all annexures. Make sure to submit the required documents against the cl 15 of technical specification.
3. Filled in QAP (Sample attached) along with CQR/annexure Q
4. Filled-in Make in India declaration on Letter head (format attached)
5. Udyam portal registration copy if MSE bidder

For any query: Kindly provide the “Trolley-Dadri” in the subject of mail.

mail: ckbharti@bhel.in; vjm@bhel.in

Ph: 9488 58 9287 / 7010 75 1675

You may raise the query through GeM also.





Bharat Heavy Electricals Ltd
Boiler Auxiliaries Plant
Ranipet-632 406

FLUE GAS DESULPHURISATION DEPT
TECHNICAL SPECIFICATION

SPECIFICATION NO: FGD:PTY:R00

REV NO:00

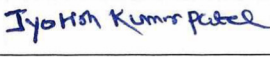
PAGE NO 01 OF 02

DATE	DESCRIPTION	PREPARED	CHECKED	APPROVED
09-09-2021	Fresh Release	 ANUPAM KUSHWAHA	 JYOTISH KUMAR PATEL	 V.KESAVAN
Sl no	Description	Specification of Platform Trolley	Vendor Acceptance /	
1	Scope of supply	1) Platform Trolley having Load carrying capacity (Rated) - 4T		
2	Overload Margin	25% on Rated capacity		
3	Material Grade	IS 2062 (MS)		
4	Numbers Of Wheels	4		
5	Wheel Material	Solid Rubber type		
6	Wheel Diameter	Minimum 400 mm		
7	Overall Dimension (length x Width x Height)	As per attached Enquiry GA drawing		
8	Thickness of Sheet	Minimum 4mm Chequered plate		
9	Outer depth of frame	100 mm		
10	Truss Member	Vendor to specify, as per vendor design.		
11	Wheel axle size	Vendor to specify, as per vendor design.		
12	Foot Brake facilities	No		
13	Finishing of surface edge	Free from sharp edges and rounded edge / corner		
14	Pulling Frame & handle	As per attached Enquiry GA drawing		
15	Weight of Trolley	Vendor to specify		
16	Type of Wheel Movement	Vendor to Specify		

BIDDER SIGN WITH SEAL AND DATE:

17	Painting	SURFACE PREPARATION: Power Tool Cleaning to St3 (SSPC-SP3)	
		PRIMER PAINT: Red Oxide Zinc Phosphate Primer to IS: 12744 (Two coats) DFT ($\mu\text{m min.}$) : 60	
		FINISH PAINT: Synthetic Enamel to IS 2932 Shade: Grey white RAL 9002 (Two coats) DFT ($\mu\text{m min.}$) : 60	
		TOTAL DFT IN ($\mu\text{m min.}$) : 120	
18	Inspection at vendor works	i) Inspection by BHEL or its authorized agency. ii) Material Test Certificates shall be submitted during inspection.	
19	Warranty	12 months on delivery	
20	Document to be submitted along with offer	i) The Vendor shall furnish point wise reply and submit seal & signed copy of this specification. ii) The Vendor shall submit the dimensional GA drawing / catalogues indicating materials of construction and weight along with the offer for information. iii) Vendor to provided Quality plan with the offer.	
21	Packing	Vendor to Specify for Packing during offer. The packing shall be strong enough to withstand without any damage to material and paint, during transit and till receipt of material at site. BHEL SITE OFFICE, 2 X 490 MW, FGD PACKAGE (STAGE 2) NCTPS — NTPC DADRI GAUTAM BUDH NAGAR, UP — 201008,INDIA	
22	Outside the Shipment	PO number, vendor name, item size, material code, model number, Quantity inside the box to be mentioned.	
23	Drawing	A typical GA drawing is attached in Enquiry for reference.	
24	Document to be submitted after PO	Vendor to submit the Platform Trolley GA drawing to BHEL before starting of manufacturing for review and approval.	

95E10-05Z-MJ-7

ALL DIMENSIONS ARE IN MM

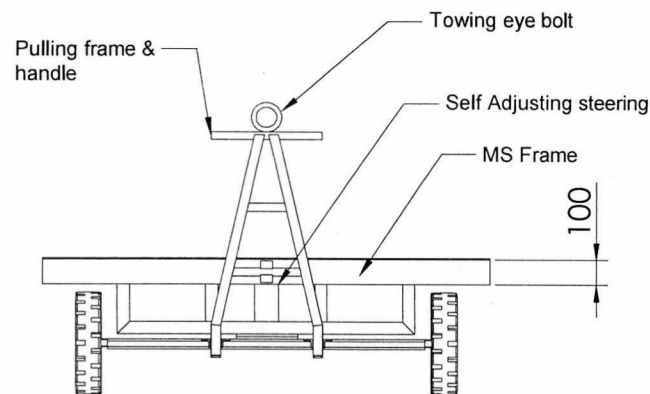
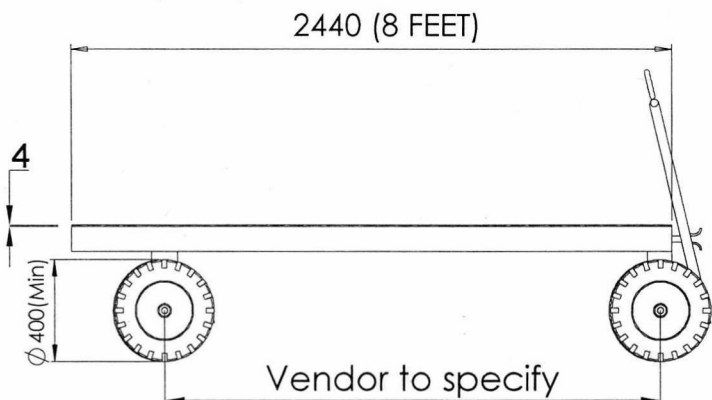
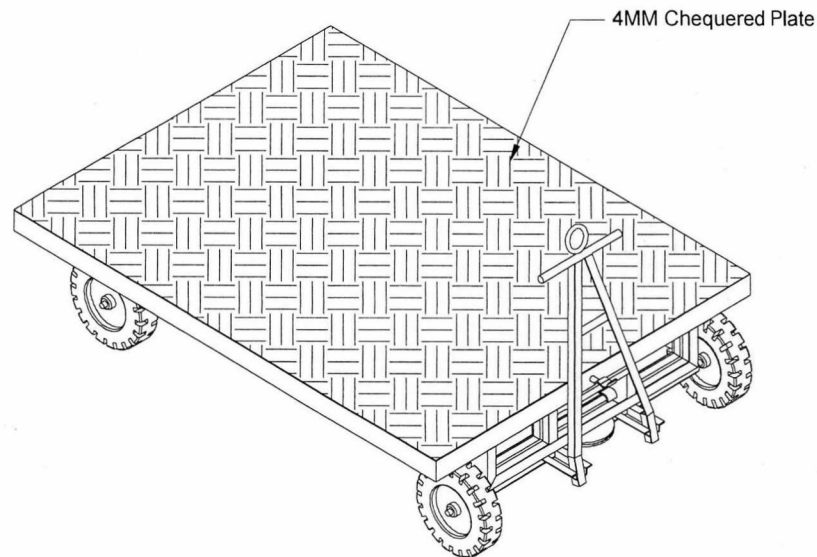
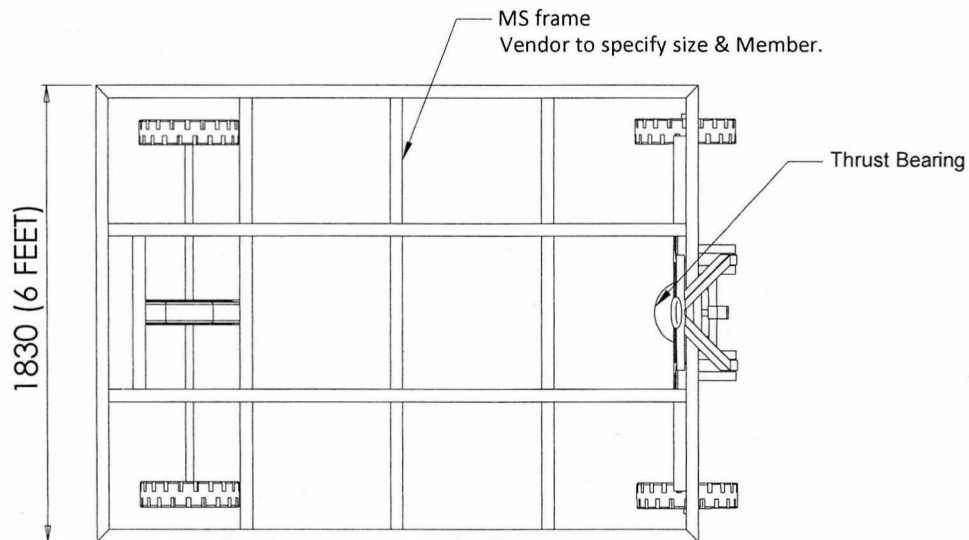

Material of Construction

1	Frame	: IS 2062 (MS)
2	Tyre	: Solid Rubber Type
3	Wheel bearing	: Vendor to specify Make and Model number
4	Steering thrust bearing	: Vendor to specify Make and Model number

NOTE:

1. DELIVERY AT DADRI SITE DELHI.

CUSTOMER NO. : G501, G502			
PROJECT : DADRI STAGE-II (2X490 MW) FLUE GAS DESULPHURIZATION SYSTEM			
 NTPC Limited <small>(A GOVERNMENT OF INDIA ENTERPRISE) ENGINEERING DIVISION, NOIDA U.P.</small>			
	BHARAT HEAVY ELECTRICALS LTD. UNIT: BOILER AUXILIARIES PLANT, RANIPET - 632 406.	NAME	SIGN
DRWN	JYOTISH KUMAR PATEL	-sd-	08-08-2021
CHD	SHANMUGA SUNDARAM S	-sd-	08-09-2021
APPD	KESAVAN V	-sd-	08-09-2021
TITLE : GA OF PLATFORM TROLLEY WITH 4MM CHEQUERED PLATE 8X6 FEET 4 TON CARRYING CAPACITY			
BHEL DRG NO. 4-FW-790-01396		SCALE : NTS	
		SHEET 01 OF 01	REV. 00

Bharat Heavy Electricals Limited
Ranipet-632406, India.
Quality Assurance (Mech)

DAD: FGD: PLATFORM TROLELY: 267
Dt. 14-09-2021

Indent No:RFW11364/00, Dt:13.09.2021	Project : DADARI (2X490 MW)
PGMA : FW790	Item: PLATFORM TROLLEY WITH CHEQUERED PLATE as per Indent.
Tech Spec: FGD: PTY, Rev: 00. Dt:09.09.2021, DRG No: 4-FW-790-01396, Rev:00	

Following are Quality recommendation

1. All the items shall be inspected at Manufacturer/Supplier works as per BHEL approved QP/Approved datasheet and Technical Specification.
2. Physical Inspection shall be done by BHEL/BHEL AIA at Manufacturer/Supplier works.
3. BHEL Approved Source is acceptable.
4. Arrange Vendor QP (Inspection Plan) for BHEL review and approval.
5. Vendor QP shall be as per attached MQP format comprising Raw Material TC review, in process and final inspection.
6. Vendor to submit applicable Catalogue also for the indented item.
7. Painting shall be as per Specification CI: 17 and Packing/ preservations of items shall be as per BHEL Specification CI:21.
8. BHEL Authorized representatives shall have the right to witness the necessary inspection and testing of goods mentioned in the PO. The supplier shall inform BHEL in advance about the readiness of the goods for inspection and testing. Inspection / Inspection wavier / approval by BHEL does not absolve Supplier's responsibility for conformity of the specification as per the terms of PO. Material Test Certificates shall be submitted to BHEL.
9. Annexure 'Q' shall be part of enquiry File and shall be filled by Supplier with their duly sign and seal.
10. **General Inspection Notes:**
 - a. Latest version of standards & Specification shall be applied.
 - b. Materials shall be procured in compliance to Functional Technical specification.
 - c. Gauges and measuring instruments with valid calibration only shall be used.
 - d. Inspection / Inspection wavier / approval by BHEL does not absolve Supplier's responsibility for conformity of the specification as per the terms of PO.
 - e. BHEL /BHEL Authorized representatives shall have the right to witness the necessary inspection and testing of goods mentioned in the PO.
 - f. In case of Vendor Drawing & Datasheet, it needs approval by BHEL Engineering.
 - g. This QP shall be read along with relevant PO, BHEL Specification / Drawing/Datasheet.

This is for your information and further necessary action at your end please.

Prepared by.
Rakesh Kr Madhu (Dy.Mgr/QA)

Reviewed & Approved by.
K Renjith(Mgr/QA)

Manufacturer's Logo, if available	MANUFACTURER'S NAME & ADDRESS:	MANUFACTURING QUALITY PLAN						PROJECT:				
		PRODUCT:						BHEL PO NO & DATE:		REV NO:		
Format No		SUB-SYSTEM :						MQP NO:		DATE: DD/MM/YYYY		PAGE: 1 OF 1
SL. NO	COMPONENT & OPERATIONS	CHARACTERISTICS	CLASS	TYPE OF CHECK	QUANTUM OF CHECK	REFERENCE DOCUMENT	ACCEPTANCE NORMS	FORMAT OF RECORD	AGENCY			REMARKS
1	2	3	4	5	6	7	8	9	M	C	N	11

1.0	RAW MATERIALS & BOUGHT OUT ITEMS (BOI):											
									√			
									√			
									√			
2.0	INPROCESS CONTROLS:											
									√			
									√			
									√			
3.0	FINAL INSPECTION :											
									√			
									√			
									√			
4.0	PAINTING, MARKING, PACKING AND PRESERVATION:											
									√			
									√			
5.0	CERTIFICATION:											
									√			
									√			
									√			

		LEGEND: * RECORDS IDENTIFIED WITH "TICK" (√) SHALL BE ESSENTIALLY INCLUDED BY SUPPLIER IN QA DOCUMENTATION. ** M: MANUFACTURER, C: BHEL / BHEL AIA, N: CUSTOMER; P: PERFORM, W: WITNESS, V: VERIFICATION; CLASS: A - CRITICAL; B - MAJOR; C - MINOR; MTC- MILL /MANUFACTURER'S TEST CERTIFICATE; IR- INSPECTION REPORT.
PREPARED BY	REVIEWED & APPROVED BY	
MANUFACTURER	MAIN SUPPLIER (BHEL)	
SIGNATURE & SEAL		

Annexure Q

	Indent No:	Enquiry no:	
Sl.No	BHEL / Customer Requirements		## Specific confirmations by the manufacturer (Acceptable/Not acceptable)
	Quality Plan Requirement: (If SQP is not given & Vendor QP applicable)		
	(i) MQP (Manufacturing Quality Plan) shall be submitted in attached format for BHEL/Customer review & approval. Our SQP/Typical MQP/ MQP Format is attached for guidance & use.		
	(ii) MQP shall invariably cover w.r.t Inward inspection including on Raw material Procurement, In process and Final inspection in elaborated way/details.		
	(iii) Bidder shall also to give specific confirmation that on need basis, their competent officials shall visit to BHEL / customer for finalization of Quality plan including test procedure/methodology during preaward / post award approval / detailed engineering in the event of an order.		
	(iv) No deviation on BHEL/Customer approved MQP/ SQP (In case BHEL SQP is provided) is acceptable.		
1	(v) Bidder shall agree to submit all cross referred documents other than codes/standards to BHEL/Customer/Consultant.		
	Important Notes shall be included in MQP : (a) Latest revision of Standard s & Specification shall apply. Only International Standards are applicable. (b) Materials shall be procured in compliance to Functional Technical Specification. (c) Inspection shall be in compliance with Approved Quality Control Procedure for the Product. (d) NDT shall be carried out by Qualified Personnel with compliance to Approved NDT Procedures and Acceptance Norms, as per ASME standard. (e) Gauges and measuring Instruments, with valid calibration only shall be used. (f) Cleaning and Painting of products shall be carried out as per Approved Painting Schedule. (g) Finished Products shall be packed to comply with Approved Packing Schedule. (h) Welding shall be carried out by Qualified Personnel with compliance to Approved NDT Procedures and Acceptance Norms, as per ASME standard.		
2	Domestic / Inland Inspection will be carried out by BHEL/BHEL appointed Third Party Inspection Agency (TPIA) / Customer/Customer Appointed Inspection Agency/Consultant. This is applicable for all Stage inspection and Final Inspection identified as "W" - Witness or "CHP" - Customer Hold Point as per customer approved Quality Plan/ Technical specification / Approved Drawing/ Approved Data sheet / Scheme / PID / PFD / SLD (Process Instrumentation Diagram / Process Flow Diagram / Single Line Diagram) etc. (as applicable).		
3	Inspection Agency for Foreign Bidders and also for Indian Bidder but importing from Foreign Sources: (1) Any one of the following Third Party Inspection Agency (TPIA) shall be appointed by the bidder and same shall be furnished by the bidder in techno commercial bid itself. (2) The details of TPIA with contact details like Name of the official, Phone no, Email id shall also to be submitted during pre/post award. However cost for such inspection agency shall be borne by the bidder only. Inspection charges for such inspection agency shall be indicated separately so that if BHEL/Customer is undertaking the inspection by on their own , then these charges are non claimable by the bidder. List of TPIA 1.M/s Bureau Veritas 2.M/s TUV-Nord 3.M/s TUV-SUD 4.M/s TUV Rheinland 5.M/s Lloyds Register 6.M/s SGS 7.M/s Germanischer Lloyds 8.M/s QUEST 9.M/s Certification Engineers International 10.M/s Intertek 11.M/s IR Class Systems and Solutions 12.M/s DNV 13. M/s Fichtner 14. M/s ABS Inspection Services		

Sl.No	BHEL / Customer Requirements	## Specific confirmations by the manufacturer (Acceptable/Not acceptable)
4	<p>Stage Inspection during manufacturing Process : Stage Inspection during manufacturing shall be carried out as per approved quality plan and all necessary documents shall be provided for review, verification and clearance for further processing. This inspection call shall be given well in advance (at least 2 weeks before) to TPI/Bidder's own inspection agency to avoid delay in the manufacturing processes.</p>	
5	<p>Inspection before despatch for domestic supplier : Inspection before despatch at supplier's works shall be carried out by BHEL appointed Inspection agency (as in Sl no. 2). Inspection shall be done as per approved Quality plan/ Technical specification/ Approved Drawing/ Approved Data sheet .</p>	
6	<p>Inspection at Foreign Source/Supplier: (a) As in sl no: 3. shall be ensured without fail (b) No material / items shall be despatched without getting the written communication from BHEL / Customer inspection carried out by Bidder appointed Third Party Inspection Agency (As per Sl no.3) / Customer/Customer Appointed Inspection Agency/Consultant. This is applicable for all Stage inspection and Final Inspection identified as "W" - Witness or "CHP" - Customer Hold Point as per customer approved Quality Plan/ Technical specification / Approved Drawing/ Approved Data sheet / Scheme / PID / PFD / SLD (Process Instrumentation Diagram / Process Flow Diagram / Single Line Diagram) etc. (As applicable). Inspection before despatch for Foreign supplier : Inspection before despatch at supplier's works shall be carried out by bidder appointed inspection agencies having international presence at vendors and or vendor's sub vendor works. Inspection shall be done as per approved Quality plan/ Technical specification/ Approved Drawing/ Approved Data sheet by TPIA mentioned in Sl no: 03 at supplier's cost.</p>	
7	<p>Painting shall be done strictly as per BHEL/Customer approved painting schedule / scheme only. Paint Thickness / Paint shade shall be ensured as per BHEL / Customer approved painting schedule / specification / data sheet etc. No deviation is acceptable unless otherwise accepted by BHEL/Customer in writing. Any conflict if any among BHEL / Customer approved painting schedule / Spec / data sheet etc. shall be brought to the notice of BHEL well in advance before proceeding including the BOI being procured for assy / skid like motors etc.</p>	
8	<p>Specific conformation for document package in the event of an order (2 Hard copies & soft copy in PDF file) is to be given containing the following with proper linkages (i) Index Sheet (ii) MQP/RQP/Endorsement Sheet (As applicable) (iii) TCs identified by BHEL/ Customer for record for "CHP" / "W" and Verification portion ("V") as given in approved QP. (iv) Final inspection report + TC including Chemical + Mechanical + HT + NDT etc. (v) Third party Inspection report + TC (vi) Customer CHP/ MDCC (vii) Type test / Performance Test reports conducted (viii) Type test / Performance Test approval/ clearance obtained from BHEL/Customer (ix) BOM with As Build Drgs with actual make / rating used with BHEL/customer approved drawings.</p>	
9	<p>Packing / Seaworthy Packing shall be as per BHEL Packing schedule / approved drg / sketch. This shall be ensured to take care transit / handling / transshipment in Road / Sea / Air. Photographs are to be submitted for BHEL review before despatching the material as per contract conditions.</p>	
10	<p>Outsourcing of test facilities: Bidder shall ensure all the testing facilities in house. However If any of the test facilities are not available with successful bidder, then bidder shall ensure the same at NABL accredited third party lab / Govt / Govt Lab for major testing such as NDT, Electrical & Mechanical testing.</p>	
11	<p>Important Note: No deviation on the above requirement 01 to 10 is acceptable with respect to Quality Requirement and those offers not meeting these specific customer requirement is liable for rejection and hence the bidder shall submit all the required documentary evidences in the offer itself.</p>	
12	<p>## Necessarily to be filled up by the bidder at the time of offer itself otherwise the offer may not be considered w.r.t Quality Requirement being customer specific requirement.</p>	

VENDOR SIGN AND STAMP:

Vendor Name & Address:

*(To be submitted In the company letter head by supplier)

Form - 1

Subject: Public Procurement (Preference to Make In india)

References:

- 1.P-45021/2/2017-B.E-II dated. 15th June-2017,
- 2.P-45021/2/2017-PP(BE-II) dated. 28th May-2018 ,
- 3.P-45021/2/2017-PP(BE-II) dated. 29th May-2019.
- 4.P-45021/2/2017-PP(BE-II) dated. 4th June-2020

We hereby declare with reference to above subject and references that M/s --
------(Tick whichever is applicable as below)

"Class-I local supplier" meeting the requirement of minimum local content equal to 50%(fifty percent) or more defined in the above government notification for the goods and services (or)

"Class-II local Supplier" meeting the requirement of local content 20% to less than 50%(fifty percent) defined in the above government notification for the goods and services

Please mention the details against the following:

Enquiry no:----- dated. -----

Type of Supplier (Class-I/Class-II)

Product:-----

Project:.....

Details of location at which local value addition will be made is as follows:

We also understand that the false declarations will be in breach of the code of Integrity under rule 175(1)(i)(h) of the General financial rules for which a bidder or its successors can be debarred for up to two years as per Rule 151(iii) of the General Financial Rules along with such other actions as may be permissible under law.

Authorized Signature M/s _____

(Signature and seal)

Place:.....

Date:.....

From.

M/s _____

Address: _____

***(To be submitted In the company letter head by supplier)**

Form – 2

I/we are bidder from _____ (Address with country). We do not belong to any of the below category mentioned.

1. Any of entity/office/workshop of your organisation/incorporation, established in a country sharing land border with India, If yes, provide the full address of all such locations.
2. Any of subsidiary of your organisation/incorporation, established in a country sharing land border with India, If yes, provide the full address of all such locations.
3. Any of entity/office/workshop of your organisation/incorporation, controlled in a country sharing land border with India, If yes, provide the full address of all such locations.
4. Any of entity whose beneficial owner is situated in a country sharing land border with India, If yes, provide the full name, address of all such locations.
5. Any Indian Agent available, If so, Provide details of address and contacts.
6. Any employee/directors who is/are citizen of country sharing land border with India, If yes, provide the full name, employee code and address of all such locations.
7. Any of consortium/joint venture of your organisation/incorporation, established in a country sharing land border with India, If yes, provide the full address of all such locations.

Meaning of beneficial owner

- 1) In case of a company or limited liability partnership, beneficial owner is the natural person, who, whether acting alone or together, or through one or more judicial person, has a controlling ownership interest or who exercises control through other means.

Explanation

- a) Controlling ownership interest means ownership of or entitlement to more than twenty-five percent of shares or capital or profits of the company.
- b) “control” shall include the right to appoint majority of the directors or to control the management rights or shareholder’s agreement or voting agreement.
- 2) In case or a partnership firm the beneficial owner is the natural person (s) who whether acting alone or together or through one or more judicial person, has ownership of the entitlement to more than fifteen percent of capital or profits of the partnership.
- 3) In case of an unincorporated association or body of individuals, the beneficial owner is the natural person(s), who, whether acting alone or together or through one or more judicial person, has ownership of the entitlement to more than fifteen percent of the property or capital or [profits of such association or body of individual.
- 4) Where no natural person is identified under (1) or (2) or (3) above, the beneficial owner is the relevant natural person who holds the position of senior managing official.
- 5) In case of a trust, the identification of beneficial owner (s) shall include identification of the author of the trust, the trustee, the beneficiaries with fifteen percent or more interest in the trust and any other natural person exercising ultimate effective control over the trust and any other

***(To be submitted In the company letter head by supplier)**

natural person exercising the ultimate effective control over the trust through a chain of control of ownership.

- 6) An agent is a person employed to do any act for another, or to represent another in dealing with third person.

We have read the clause regarding restriction on procurement from a bidder of a country which shares a land border with India, we hereby declare that we do not belongs to any such country and are eligible to be considered.

In case, any of information is found to be false, even after bid acceptance, immediate termination may happen and action will be taken as per law.

Format is being filled without altering any of the clause mentioned in the given format**

Dated: _____

Authorised Sign and stamp_____