

CAUTION: The information on this document is the property of BHARAT HEAVY ELECTRICALS LTD. It must not be used directly or indirectly in any way detrimental to the interest of the company.

REV	DATE	ALTERED
		CHECKED

ALL DIMENSIONS ARE IN MILLIMETRES

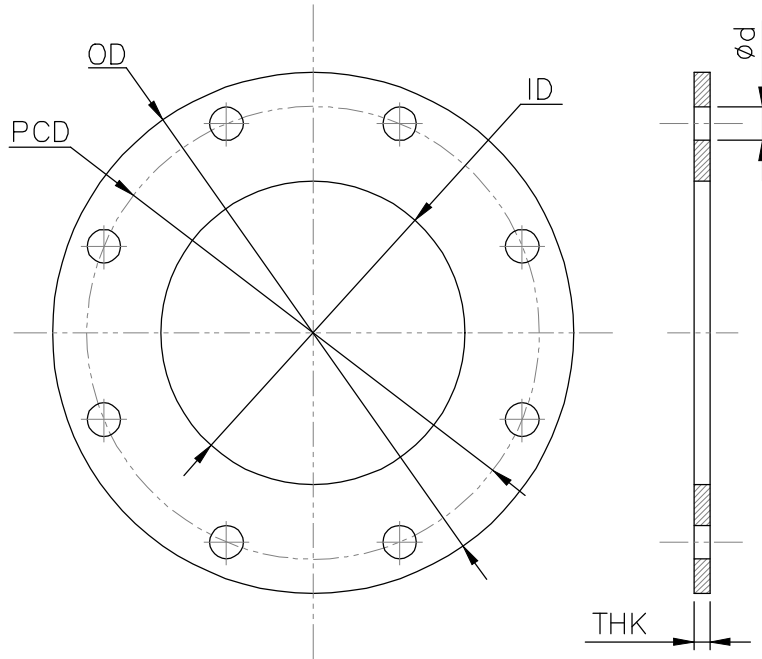

### PTFE GASKET

#### DIMENSION DETAILS

ITEM NO	SIZE (NB)	ID (MM)	OD (MM)	PCD (MM)	HOLE DIA	HOLE NOS.	THK (MM)	DRILLING STANDARD
1	50	62	150	120.7	19	4	4	ASME B16.5 #150.
2	80	91	190	152.4	19	4	4	ASME B16.5 #150.
3	100	114	230	190.5	19	8	4	ASME B16.5 #150.
4	125	141	254	215.9	22	8	4	ASME B16.5 #150.
5	150	168	279	241.3	22	8	4	ASME B16.5 #150.
6	200	221.5	343	298.5	22	8	4	AWWA C207 CLASS D
7	250	276	406	362	26	12	4	AWWA C207 CLASS D

#### NOTES

1. MATERIAL: PTFE (ANTI-CORROSION, COMPRESSED, NON-ASBESTOS TYPE).
2. OPERATING TEMP. OF FLUID SHALL BE 30° C TO 150° C.

FOR TENDER PURPOSE ONLY

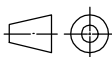
	<b>BHARAT HEAVY ELECTRICALS LTD.,</b> UNIT: BOILER AUXILIARIES PLANT. RANIPET - 632 406.		DRN	NAME	SIGN	DATE	NO. OF VAR
			CHD	M.VIGNESH		22.01.22	
			APPD	DHEERAJ KR		22.01.22	
DEPT WS	GRADE OF UNTOL.DIM		SCALE	WEIGHT (KG).	REF. TO ASSY./OLD DRG.		ITEM NO.
CODE 9776	PR: QA: 500		NTS	---			
TITLE			CARD CODE	DRAWING NO.			REV
PTFE GASKET			U 01	4-FW-000-01471			00

**CQR (CONTRACT QUALITY REQUIREMENT)**  
**Quality Assurance (Mech)**

PANKI: PTFE GASKETS: 695

Dt. 05-04-2023

Project: PANKI (1X660 MW)

SL No	Item Name	Indent No	PGMA	Drawing
01	PTFE GASKETS	RFW21958	FW867	4-FW-000-01471

Following are Quality requirements:

1. Inspection of all the items applicable at Vendor works as per BHEL QP(PTFE GASKET:393/01,DT:10.12.2020) /Specification/ Approved Drawing/ Approved Data sheet.
2. Physical Inspection shall be done by BHEL/BHEL AIA, at Vendor works.
3. Packing of items shall be as per BHEL Engg Approved Packing Drawing/Packing Specifications.
4. BHEL Authorized representatives shall have the right to witness the necessary inspection and testing of goods mentioned in the PO. The supplier shall inform BHEL in advance about the readiness of the goods for inspection and testing. Inspection / Inspection wavier / approval by BHEL does not absolve Supplier's responsibility for conformity of the specification as per the terms of PO. Material Test Certificates shall be submitted to BHEL.
5. Annexure 'Q' shall be part of enquiry File and shall be filled by Supplier with their duly sign and seal.
6. Supplier should be manufacturer not a trader/Agent. *(If the OEM/Principal engaging the services of an agent to participate on their behalf, vendor will be acceptable with respect to Quality requirement provided acceptance on Point No 2,3, 6 and 8 shall be accepted to supplier)*
7. **General Inspection Notes:**
  - a. Latest version of standards & Specification shall be applied.
  - b. Materials shall be procured in compliance to Functional Technical specification.
  - c. Gauges and measuring instruments with valid calibration only shall be used.
  - d. Inspection / Inspection wavier / approval by BHEL does not absolve Supplier's responsibility for conformity of the specification as per the terms of PO.
  - e. BHEL /BHEL Authorized representatives shall have the right to witness the necessary inspection and testing of goods mentioned in the PO.
  - f. In case of Vendor Drawing & Datasheet, it needs approval by BHEL Engineering.
  - g. QP shall be read along with relevant PO, BHEL Specification / Approved Drawing/Datasheet.

Sd\ - Rakesh Kr Madhu  
Dy/Mgr-QA

Sd\ - K Renjith  
Mgr/QA

1397589/2023/BAP-QA

MECH



Ranipet

MANUFACTURER'S NAME &  
ADDRESSBHEL/ BHEL APPROVED  
SOURCE

## STANDARD QUALITY PLAN

ITEM: PTFE GASKETS

QP. NO.: PTFE GASKET :393

Rev No. :01



Date: 10.12.2020

Page 1 of 2

PROJECT: AS PER PO.

SL NO	COMPONENT & OPERATION	CHARACTERISTICS	CLASS OF CHECK	TYPE OF CHECK	QUANTUM OF CHECK		REFERENCE DOCUMENTS	ACCEPTANCE NORMS	FORMAT OF RECORD		Agency			REMARKS
					6				9	D	M	B	C	
1	2	3	4	5	M	B/C	7	8	9	D	**10			11

1.0 RAW MATERIALS (Polytetrafluoroethylene)													
1.1	PTFE	Appearance and Density	Major	Visual & Measurement	One Sample / Batch		Manufacturer Plant Procedure/ Relevant Standard/ Approved Datasheet/ Drawing	TC	√	P	V	-	
1.2	PTFE	Tensile Strength & Elongation	Major	Measurement	One Sample / Batch		Manufacturer Plant Procedure/ Relevant Standard/ Approved Datasheet/ Drawing	TC	√	P	V	-	
1.3	PTFE	Hardness	Major	Measurement	One Sample / Batch		Manufacturer Plant Procedure/ Relevant Standard/ Approved Datasheet/ Drawing	TC	√	P	V	-	
2.0 INPROCESS CONTROL													
2.1	Machining	Cutting/Machining	Major	Dimension Measurement	100%	100%	Datasheet/ Drawing	Report	√	P	V	-	
3.0 FINAL INSPECTION													
3.1	Final Testing of PTFE Gasket	Visual & Dimension	Major	Visual & Measurement	100%	100%	P.O. / Material Specification/ Relevant Standard/ Approved Datasheet/ Drawing	Report	√	P	W	-	
3.2	Identification, Packing & Preservations	Visual	Major	Visual	100%	100%	P.O. / Material Specification/ Relevant Standard/ Approved Datasheet/ Drawing	COC	-	P	V	-	

Manufacturer/ Supplier	Legends:	Prepared by	Reviewed and Approved by
	M – Manufacturer / Subcontractor, B - BHEL /BHEL Authorized Inspection Agency, C – Customer/ Customer Authorized Inspection Agency, P - perform, V - Verification of reports W - Witness, TC - Test certificate "D" – Record, identified with tick (√) shall be essentially included by Supplier in QA documentation. COC- Certificate of Conformance.		
Sign & Stamp with date		Rakesh Kr Madhu/Dy Mgr(QA)	K Renjith (Mgr/QA)

1397589/2023/BAP-QA

MECH



Ranipet

MANUFACTURER'S NAME &  
ADDRESSBHEL/ BHEL APPROVED  
SOURCE

## STANDARD QUALITY PLAN

ITEM: PTFE GASKETS

QP. NO.: PTFE GASKET :393

Rev No. :01

Date: 10.12.2020

Page 2 of 2

PROJECT: AS PER PO.

SL NO	COMPONENT & OPERATION	CHARACTERISTICS	CLASS OF CHECK	TYPE OF CHECK	QUANTUM OF CHECK		REFERENCE DOCUMENTS	ACCEPTANCE NORMS	FORMAT OF RECORD		Agency			REMARKS
					6				9	D	M	B	C	
1	2	3	4	5	M	B/C	7	8	9	D	**10			11



## Note:

1. Materials shall be procured in compliance to Functional Technical Specification/Drawing.
2. Gauges and measuring Instruments, with valid calibration only shall be used
3. Finished Products shall be packed to comply with approved Packing Schedule..
4. All the inspection report as per P.O. shall be submitted to BHEL for Review and record purpose.

**\*\* This QP Shall be read along with relevant P.O. and BHEL Drawing/Specification.**

Record of revision

REV NO	DATE	DESCRIPTION
00	14.03.2020	Original Issue
01	10.12.2020	Reviewed and totally revised

Manufacturer/ Supplier	Legends:	Prepared by	Reviewed and Approved by
	M – Manufacturer / Subcontractor, B - BHEL /BHEL Authorized Inspection Agency, C – Customer/ Customer Authorized Inspection Agency, P - perform, V - Verification of reports W - Witness, TC - Test certificate "D" – Record, identified with tick (√) shall be essentially included by Supplier in QA documentation. COC- Certificate of Conformance.		
Sign & Stamp with date		Rakesh Kr Madhu/Dy Mgr(QA)	K Renjith (Mgr/QA)

## Annexure Q

		Indent No:	Enquiry no:	
Sl.No	BHEL / Customer Requirements	## Specific confirmations by the manufacturer (Acceptable/Not acceptable)		
	<b>Quality Plan Requirement: (If SQP is not given &amp; Vendor QP applicable)</b>			
	(i) MQP (Manufacturing Quality Plan) shall be submitted in attached format for BHEL/Customer review & approval. Our SQP/Typical MQP/ MQP Format is attached for guidance & use.			
	(ii) MQP shall invariably cover w.r.t Inward inspection including on Raw material Procurement, In process and Final inspection in elaborated way/details.			
	(iii) Bidder shall also to give specific confirmation that on need basis, their competent officials shall visit to BHEL / customer for finalization of Quality plan including test procedure/methodology during preaward / post award approval / detailed engineering in the event of an order.			
	(iv) No deviation on BHEL/Customer approved MQP/ SQP (In case BHEL SQP is provided) is acceptable.			
1	(v) Bidder shall agree to submit all cross referred documents other than codes/standards to BHEL/Customer/Consultant.			
	<b>Important Notes shall be included in MQP :</b> (a) Latest revision of Standard s & Specification shall apply. Only International Standards are applicable. (b) Materials shall be procured in compliance to Functional Technical Specification. (c) Inspection shall be in compliance with Approved Quality Control Procedure for the Product. (d) NDT shall be carried out by Qualified Personnel with compliance to Approved NDT Procedures and Acceptance Norms, as per ASME standard. (e) Gauges and measuring Instruments, with valid calibration only shall be used. (f) Cleaning and Painting of products shall be carried out as per Approved Painting Schedule. (g) Finished Products shall be packed to comply with Approved Packing Schedule. (h) Welding shall be carried out by Qualified Personnel with compliance to Approved NDT Procedures and Acceptance Norms, as per ASME standard.			
2	<b>Domestic / Inland Inspection</b> will be carried out by BHEL/BHEL appointed Third Party Inspection Agency (TPIA) / Customer/Customer Appointed Inspection Agency/Consultant. This is applicable for all Stage inspection and Final Inspection identified as "W" - Witness or "CHP" - Customer Hold Point as per customer approved Quality Plan/ Technical specification / Approved Drawing/ Approved Data sheet / Scheme / PID / PFD / SLD (Process Instrumentation Diagram / Process Flow Diagram / Single Line Diagram) etc. (as applicable).			
3	<b>Inspection Agency for Foreign Bidders and also for Indian Bidder but importing from Foreign Sources:</b> (1) Any one of the following Third Party Inspection Agency (TPIA) shall be appointed by the bidder and same shall be furnished by the bidder in techno commercial bid itself. (2) The details of TPIA with contact details like Name of the official, Phone no, Email id shall also to be submitted during pre/post award. However cost for such inspection agency shall be borne by the bidder only. Inspection charges for such inspection agency shall be indicated separately so that if BHEL/Customer is undertaking the inspection by on their own , then these charges are non claimable by the bidder. For NTPC Project ensure TPI Approved by NTPC. Refer our QC Procurement email in this regard. <b>List of TPIA</b> 1.M/s Bureau Veritas 2.M/s TUV-Nord 3.M/s TUV-SUD 4.M/s TUV Rheinland 5.M/s Lloyds Register 6.M/s SGS 7.M/s Germanischer Lloyds 8.M/s QUEST 9.M/s Certification Engineers International 10.M/s Intertek 11.M/s IR Class Systems and Solutions 12.M/s DNV 13. M/s Fichtner 14. M/s ABS Inspection Services			

Sl.No	BHEL / Customer Requirements	## Specific confirmations by the manufacturer (Acceptable/Not acceptable)
4	<b>Stage Inspection during manufacturing Process</b> : Stage Inspection during manufacturing shall be carried out as per approved quality plan and all necessary documents shall be provided for review, verification and clearance for further processing. This inspection call shall be given well in advance (at least 2 weeks before) to TPI/Bidder's own inspection agency to avoid delay in the manufacturing processes.	
5	<b>Inspection before despatch for domestic supplier</b> : Inspection before despatch at supplier's works shall be carried out by BHEL appointed Inspection agency (as in Sl no. 2). Inspection shall be done as per approved Quality plan/ Technical specification/ Approved Drawing/ Approved Data sheet .	
6	<b>Inspection at Foreign Source/Supplier:</b> (a) As in sl no: 3. shall be ensured without fail (b) No material / items shall be despatched without getting the written communication from BHEL / Customer inspection carried out by Bidder appointed Third Party Inspection Agency (As per Sl no.3) / Customer/Customer Appointed Inspection Agency/Consultant. This is applicable for all Stage inspection and Final Inspection identified as "W" - Witness or "CHP" - Customer Hold Point as per customer approved Quality Plan/ Technical specification / Approved Drawing/ Approved Data sheet / Scheme / PID / PFD / SLD (Process Instrumentation Diagram / Process Flow Diagram / Single Line Diagram) etc. (As applicable). Inspection before despatch for Foreign supplier : Inspection before despatch at supplier's works shall be carried out by bidder appointed inspection agencies having international presence at vendors and or vendor's sub vendor works. Inspection shall be done as per approved Quality plan/ Technical specification/ Approved Drawing/ Approved Data sheet by TPIA mentioned in Sl no: 03 at supplier's cost.	
7	<b>Painting</b> shall be done strictly as per BHEL/Customer approved painting schedule / scheme only. Paint Thickness / Paint shade shall be ensured as per BHEL / Customer approved painting schedule / specification / data sheet etc. No deviation is acceptable unless otherwise accepted by BHEL/Customer in writing. Any conflict if any among BHEL / Customer approved painting schedule / Spec / data sheet etc. shall be brought to the notice of BHEL well in advance before proceeding including the BOI being procured for assy / skid like motors etc.	
8	Specific conformation for document package in the event of an order (2 Hard copies & soft copy in PDF file) is to be given containing the following with proper linkages (i) Index Sheet (ii) MQP/RQP/Endorsement Sheet (As applicable) (iii) TCs identified by BHEL/ Customer for record for "CHP" / "W" and Verification portion ("V") as given in approved QP. (iv) Final inspection report + TC including Chemical + Mechanical + HT + NDT etc. (v) Third party Inspection report + TC (vi) Customer CHP/ MDCC (vii) Type test / Performance Test reports conducted (viii) Type test / Performance Test approval/ clearance obtained from BHEL/Customer (ix) BOM with As Build Drgs with actual make / rating used with BHEL/customer approved drawings.	
9	<b>Packing / Seaworthy Packing</b> shall be as per BHEL Packing schedule / approved drg / sketch. This shall be ensured to take care transit / handling / transshipment in Road / Sea / Air. Photographs are to be submitted for BHEL review before despatching the material as per contract conditions.	
10	<b>Outsourcing of test facilities:</b> Bidder shall ensure all the testing facilities in house. However If any of the test facilities are not available with successful bidder, then bidder shall ensure the same at NABL accredited third party lab / Govt / Govt Lab for major testing such as NDT, Electrical & Mechanical testing.	
11	<b>Important Note:</b> No deviation on the above requirement 01 to 10 is acceptable with respect to Quality Requirement and those offers not meeting these specific customer requirement is liable for rejection and hence the bidder shall submit all the required documentary evidences in the offer itself.	
12	## Necessarily to be filled up by the bidder at the time of offer itself otherwise the offer may not be considered w.r.t Quality Requirement being customer specific requirement.	

VENDOR SIGN AND STAMP:

Vendor Name &amp; Address:

\*(To be submitted In the company letter head by supplier)

## Form - 1

**Subject:** Public Procurement (Preference to Make In india)

**References:**

- 1.P-45021/2/2017-B.E-II dated. 15<sup>th</sup> June-2017,
- 2.P-45021/2/2017-PP(BE-II) dated. 28<sup>th</sup> May-2018 ,
- 3.P-45021/2/2017-PP(BE-II) dated. 29<sup>th</sup> May-2019.
- 4.P-45021/2/2017-PP(BE-II) dated. 4<sup>th</sup> June-2020

We hereby declare with reference to above subject and references that M/s --  
------(Tick whichever is applicable as below)

"Class-I local supplier" meeting the requirement of minimum local content equal to 50%(fifty percent) or more defined in the above government notification for the goods and services (or)

"Class-II local Supplier" meeting the requirement of local content 20% to less than 50%(fifty percent) defined in the above government notification for the goods and services

Please mention the details against the following:

Enquiry no:----- dated. -----

Type of Supplier (Class-I/Class-II) .....

Product:-----

Project:.....

Details of location at which local value addition will be made is as follows:

\_\_\_\_\_

We also understand that the false declarations will be in breach of the code of Integrity under rule 175(1)(i)(h) of the General financial rules for which a bidder or its successors can be debarred for up to two years as per Rule 151(iii) of the General Financial Rules along with such other actions as may be permissible under law.

Authorized Signature M/s \_\_\_\_\_

(Signature and seal)

Place:.....

Date:.....

From.

M/s \_\_\_\_\_

Address: \_\_\_\_\_

**\*(To be submitted In the company letter head by supplier)**

## **Form – 2**

I/we are bidder from \_\_\_\_\_ (Address with country). We do not belong to any of the below category mentioned.

1. Any of entity/office/workshop of your organisation/incorporation, established in a country sharing land border with India, If yes, provide the full address of all such locations.
2. Any of subsidiary of your organisation/incorporation, established in a country sharing land border with India, If yes, provide the full address of all such locations.
3. Any of entity/office/workshop of your organisation/incorporation, controlled in a country sharing land border with India, If yes, provide the full address of all such locations.
4. Any of entity whose beneficial owner is situated in a country sharing land border with India, If yes, provide the full name, address of all such locations.
5. Any Indian Agent available, If so, Provide details of address and contacts.
6. Any employee/directors who is/are citizen of country sharing land border with India, If yes, provide the full name, employee code and address of all such locations.
7. Any of consortium/joint venture of your organisation/incorporation, established in a country sharing land border with India, If yes, provide the full address of all such locations.

### **Meaning of beneficial owner**

- 1) In case of a company or limited liability partnership, beneficial owner is the natural person, who, whether acting alone or together, or through one or more judicial person, has a controlling ownership interest or who exercises control through other means.

### **Explanation**

- a) Controlling ownership interest means ownership of or entitlement to more than twenty-five percent of shares or capital or profits of the company.
- b) “control” shall include the right to appoint majority of the directors or to control the management rights or shareholder’s agreement or voting agreement.
- 2) In case or a partnership firm the beneficial owner is the natural person (s) who whether acting alone or together or through one or more judicial person, has ownership of the entitlement to more than fifteen percent of capital or profits of the partnership.
- 3) In case of an unincorporated association or body of individuals, the beneficial owner is the natural person(s), who, whether acting alone or together or through one or more judicial person, has ownership of the entitlement to more than fifteen percent of the property or capital or [profits of such association or body of individual.
- 4) Where no natural person is identified under (1) or (2) or (3) above, the beneficial owner is the relevant natural person who holds the position of senior managing official.
- 5) In case of a trust, the identification of beneficial owner (s) shall include identification of the author of the trust, the trustee, the beneficiaries with fifteen percent or more interest in the trust and any other natural person exercising ultimate effective control over the trust and any other

**\*(To be submitted In the company letter head by supplier)**

natural person exercising the ultimate effective control over the trust through a chain of control of ownership.

- 6) An agent is a person employed to do any act for another, or to represent another in dealing with third person.

We have read the clause regarding restriction on procurement from a bidder of a country which shares a land border with India, we hereby declare that we do not belongs to any such country and are eligible to be considered.

In case, any of information is found to be false, even after bid acceptance, immediate termination may happen and action will be taken as per law.

Format is being filled without altering any of the clause mentioned in the given format\*\*

Dated: \_\_\_\_\_

Authorised Sign and stamp\_\_\_\_\_