

1219056/2022/BAP-9781\_COML

**Pre-Qualification Requirement  
To**

**Participate in Tender for Rubber Expansion Joint Procurement  
(To be submitted along with Offer for Technical BID Evaluation)**

**Following are the Pre-Qualification Requirement**

Sl No.	Criteria	Document proofs to be submitted	Bidder Compliance (Yes/No/Comment)
01	Bidder should be a Manufacturer of Rubber Expansion Joints.	Registration certificate / Certificate of Incorporation/Self declaration	
02	Experience Certificates (PO copies of REJ of similar sizes)	A) List of customers to whom rubber expansion joints of similar sizes supplied, B) Unpriced PO copy of similar sizes and relevant (i) Proof of supply (such as Invoice/ SRV/GRN/LWB). (ii) Test report & Inspection report of same PO.	
03	Bidders shall not have been black-listed / kept on hold /given Business holiday for a specified period by any Public Sector Undertaking or Government Departments/any other units of BHEL.	Self-declaration to be submitted by Bidder.	
04	Confirmation to the Specification / Drawing / Dimension / Size, Quality plan and Inspection check list.	Sealed and Signed copy of Technical specification FWQS:024 Rev02 with point wise reply shall be submitted as a proof of conformity.	

- BHEL reserves the right to verify information / confirmation furnished by asking additional documents Proofs etc.
- BHEL reserves the right to visit supplier's works to audit and inspect to ensure the capability for technical evaluation.
- Compliance to all the above Pre-qualification requirements is mandatory. In absence of PQR compliance vendor's offer are liable for rejection.

**Declaration:**

We understand that all the proofs/documents submitted by our firm for all the above points are subject to verification and in case BHEL finds any discrepancy in any of the documents submitted by us like fake/false/forged documents, Certificates or information, action may be taken against our firm as per extant guidelines of BHEL.

**Bidder's Seal & Signature**

	<b>Bharat Heavy Electricals Ltd</b> <b>Boiler Auxiliaries Plant</b> Ranipet-632 406	<b>FLUE GAS DESULPHURIZATION</b> <b>DEPT. TECHNICAL</b> <b>SPECIFICATION</b>
	<b>TECHNICAL SPECIFICATION: FWQS:024</b>	

02	30.10.2022	REJ NB80 SIZE INCLUSION	<i>Anupam K</i> ANUPAM K	<i>Jyotish K Patel</i> JYOTISH K PATEL	<i>V.Kesavan</i> V.KESAVAN
01	01.09.2022	Datasheet modifications	ANUPAM K	JYOTISH K PATEL	V.KESAVAN
00	25.06.2021	FRESH RELEASE	ANUPAM K	SHANMUGA S S	V.KESAVAN
REV	DATE	DESCRIPTION	PREPARED	CHECKED	APPROVED

Sl.no	Item	RUBBER EXPANSION JOINTS	Vendor Acceptance/ Comments
1	Scope of supply	<p>The scope covers the design, manufacturing, testing, packing and supply of rubber Expansion Joints for pipelines in the duty condition as specified in datasheet.</p> <p>(1) Supply of rubber expansion joint with swiveling metallic flanges with fasteners (Galvanized).</p> <p>(2) Galvanised control plates (shall be welded with flanges)</p> <p>(3) Galvanised control rods (Tie rod) with Nuts, bolts &amp; Washers</p>	
2	Qualification (PQR) criteria	<p>(a) Vendor should be a manufacturer of Rubber Expansion Joints.</p> <p>(b) Vendor shall submit the list of previously supplied REJ similar /higher sizes, with customer names along with at least one unpriced PO copy as proof of experience.</p> <p>(c) Previous inspection/ test report to be furnished for the similar/higher sizes along with offer.</p>	
3	Sizes	350NB,300NB,200NB,150 NB,125 NB,100 NB &80NB	
4	Application-Fluid	Gypsum Slurry : <b>350NB,300NB &amp; 200NB</b> Air/Water : <b>150NB,125NB ,100NB &amp; 80NB</b>	
5	Type	<b>Filled Single Arch Type for: 350NB, 300NB &amp; 200NB sizes</b> <b>Open Single Arch Type for : 150NB,125 NB,100NB &amp;80NB sizes</b>	
6	Flange	All holes and dimensions shall be as per ANSI B16.5 Class 150	
7	Connection Type	Minimum One side flange shall be loose/slip-on swivelling type. <b>Note:</b> Flanges will be in single piece (both ends). Split type of flange is not acceptable.	
8	Galvanizing	Flanges, Control Plates, Control Rods, Nuts & Washers all shall be galvanized- <b>40μ thick.</b>	

Bidder's sign &amp; seal

9	Sample requirement	During enquiry stage, one number of typical sample of rubber expansion joint to be sent to BHEL for review.  <b>Note:</b> Vendors who have earlier sent their REJ sample to BAP, RANIPET, need not to send again. Proof of earlier sent of REJ sample such as Delivery copy / LR copy /E-mail Reference etc. shall be enclosed along with Vendor offer. Other new vendors must send their typical sample of REJ to BHEL BAP RANIPET.	
10	Inspection at vendor works	(a) Inspection by BHEL or its authorized agency. (b) Material Test Certificates from authorized NABL Lab shall be submitted during inspection.	
11	Documents to be furnished: (1) During the offer stage- (a), (b)& (c) (2) After placement of order (d) & (e)	(a) The Vendor shall furnish duly signed of this specification and PQR with seal providing pointwise confirmation. (b) Manufacturing product catalogue. (c) Dimensional drawing with indicating MOC and weight. (d) Vendor to provide Quality plan. (e) Test certificates. i) Hydro test certificate. ii) Material composition certificate. iii) Routine test of dimensional compliance. iv) Standard test methods and copies of certificate.	
12	Packing	(a) Rubber Expansion Joints of each size/ Type/ rating/ Standard/ Material should be suitably packed separately. Each package shall marked with same above so that the Expansion Joints shall be Identified easily (b) The part items of the equipment should be identified by the tag numbers and should be packed as to minimize the possibility of damage during storage or transit. The equipment shall be protected for a storage of 12 months at site, if any extra precaution is to be taken by the Purchaser for storage beyond 18 months the same shall be explicitly indicated in the operation and maintenance manuals.	
13	Outside the packing	PO number, vendor name, item size, material code, model number, quantity inside the box, gross weight and net weight to be mentioned.	
14	Drawing	Typical drawing is attached for reference.	
15	Guarantee & Warranty	Vendor shall guarantee for trouble free operation and against defects of quality, workmanship of the product for a period of 18 months from the date of supply or 12 months from the commissioning, whichever is earlier.	
16	Design life	15000 cycles	
17	Design standard	Vendor to specify	
18	Operation condition	REJ shall not go permanent set/ deformation under the operating conditions.	

**TECHNICAL DATASHEET FOR RUBBER EXPANSION JOINTS**

Sl. No.	1	2	3	4	5	6	7	8
<b>Location</b>	RC Spray Header	RC Spray Header	JAS Input	JAS Input / Mist Eliminator Washing Pipe Inlet	Mist Eliminator Washing Pipe Inlet	Mist Eliminator Washing Pipe Inlet	Mist Eliminator Washing Pipe Inlet	Vendor to Confirm
<b>Flow media</b>	<b>Gypsum Slurry</b>	<b>Gypsum Slurry</b>	<b>Gypsum Slurry</b>	<b>Air/ Water</b>	<b>Water</b>	<b>Water</b>	<b>Water</b>	
<b>Purpose</b>	Anti-Vibration/ Displacement	Anti-Vibration / Displacement	Anti-Vibration / Displacement	Anti-Vibration / Displacement	Anti-Vibration / Displacement	Anti-Vibration / Displacement	Anti-Vibration / Displacement	
<b>Pipe Size</b>	<b>NB 350</b>	<b>NB 300</b>	<b>NB 200</b>	<b>NB 150</b>	<b>NB125</b>	<b>NB 100</b>	<b>NB 80</b>	
<b>Arch type</b>	<b>Filled</b>	<b>Filled</b>	<b>Filled</b>	<b>Open</b>	<b>Open</b>	<b>Open</b>	<b>Open</b>	
<b>Face-To-Face Length (including rubber lining)</b>	<b>200mm</b>	<b>150 mm</b>	<b>150 mm</b>	<b>150 mm</b>	<b>150 mm</b>	<b>150 mm</b>	<b>150 mm</b>	
<b>Service conditions</b>	<b>Operating Temp. (Deg.C)</b>	70	70	100	100	70	70	70
	<b>Design Temp. (Deg.C)</b>	80	80	110	110	80	80	80
	<b>Working pressure (g) kg/cm<sup>2</sup></b>	8	8	8	8	8	8	8
	<b>Hydro Test Pressure kg/cm<sup>2</sup> (g)</b>	12	12	12	12	12	12	12
	<b>Installation Position</b>	Horizontal/ Vertical/ Inclined	Horizontal/ Vertical/ Inclined	Horizontal/ Vertical/ Inclined	Horizontal/ Vertical/ Inclined	Horizontal/ Vertical/ Inclined	Horizontal/ Vertical/ Inclined	Horizontal/ Vertical/ Inclined
<b>Shore Hardness</b>	65±5 shore A	65±5 shore A	65±5 shore A	65±5 shore A	65±5 shore A	65±5 shore A	65±5 shore A	
<b>Axial Movement (mm)</b>	<b>Compression</b>	30*	30*	30*	19	19	19	19
	<b>Extension</b>	17*	17*	17*	11	11	11	11
<b>Lateral Movement (mm)</b>	19*	19*	16*	16	16	16	16	
<b>Flange Details</b>	O.D. (mm)	534	483	343	279	254	229	190.5
	PCD (mm)	476.2	431.8	298.5	241.3	215.9	190.5	152.4
	Bolt Hole Dia. (mm)	28.4	25.4	22.2	22.2	22.2	19.1	19
	No. Of Hole (nos.)	12	12	8	8	8	8	4
	Thickness (mm) as per ANSI B16.5	35	32	28	25	24	24	24

Control Rod Length (mm)	380±5	300±5	300±5	300±5	300±5	300±5	300±5	
Control Rod dia. (Ø)mm	Ø24	Ø24	Ø16	Ø16	Ø16	Ø16	Ø16	
Control plate thick (mm)Min.	26	24	20	18	18	18	18	

\* Compression, extension & lateral movement are given for wide open arch.

Vendor to furnish maximum movement values for wide filled arch type REJ during tender stage. It should be less than 50% of the above values.

### Material of Construction:

ITEM	MATERIAL	Vendor Acceptance/Comments
Fixed Flange	IS 2062+ Chloroprene Rubber	
Loose Flange	IS 2062+ Chloroprene Rubber	
Rubber Outer Cover	EPDM	
Reinforcing Fabric	Chemical fibre	
Reinforcing Cord	Chemical fibre	
Rubber Inner Tube	Chloroprene Rubber	
Control Ring/Plate (Control plates shall be welded on the flanges. Bolted type is not acceptable)	IS:2062 Gr. A With 40 µ Galvanised.	
Tie Rod/control bolt, Nut, Lock nut & Washer	IS:1367 CL 8.8 With 40 µ Galvanised	

**Remarks:** One Set of Rubber Expansion joint/bellow consists of following items explained in below table-

Items	350 NB/300 NB	200NB/150NB/125NB/100NB/80NB	Vendor Acceptance /Comments
Bellow	1 no.	1 no.	
Flange(1 fixed +1 slip on)	2 nos.	2 nos.	
Control plates	8 nos.	4 nos.	
Tie rod/Control bolts	4 nos.	2 nos.	
Nut	16 nos.	8 nos.	
Lock Nut	16 nos.	8 nos.	
Washer	16 nos.	8 nos.	

Note: For FGD application wide arch design only applicable.

TYPICAL DRAWING OF RUBBER EXPANSION JOINT WITH BOM

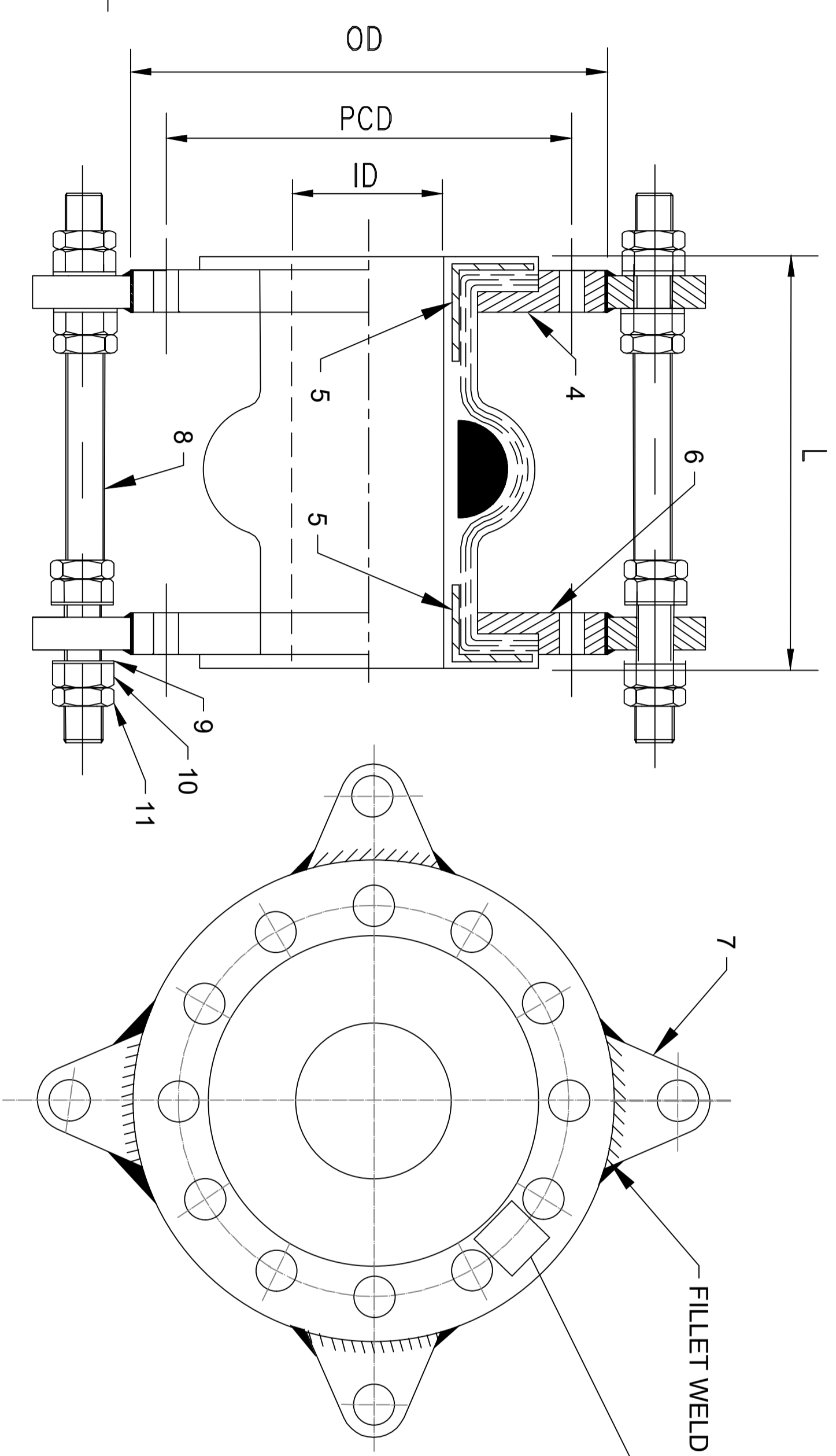

DETAIL OF CONSTRUCTION

FILLED WITH SOFT RUBBER

NOTE:  
 1. NOT APPLICABLE TO 150, 125, 100 & 80NB SIZES.  
 2. APPLICABLE TO 350, 300 & 200NB SIZES ONLY.

PRINTED METAL PLATE FIXED ON THE INNER SIDE OF METAL FLANGE.  
 PO NO:  
 MATERIAL CODE:  
 REL SIZE:  
 APPLICATION : SLURRY OR AIR / WATER  
 MFG. MONTH & YEAR

PART NO.	NAME OF PART	MATERIAL	QNTY IN NOS. (FOR 300NB & ABOVE)	QNTY IN NOS. (FOR 300NB & BELOW)
11	LOCK NUT	IS 1367 CL 8.8 +GAL 40μ	4X4	4X2
10	NUT	IS 1367 CL8.8 +GAL 40μ	4X4	4X2
9	WASHER	IS 2016 CL 8.8+GAL 40μ	4X4	4X2
8	CONTROL ROD	IS 1367 CL8.8 +GAL 40μ	4	2
7	CONTROL PLATE	IS 2062+GAL 40μ	4X2	2X2
6	LOOSE FLANGE	IS 2062+CR+GAL 40μ	1	1
5	NIPPLE	IS 2062+GAL 40μ	2	2
4	FLANGE	IS 2062+ CR+GAL 40μ	1	1
3	RUBBER OUTER COVER	EPDM		
2	REINFORCING FABRIC	CHEMICAL FIBER		
1	RUBBER INNER TUBE	CHLOROPRENE RUBBER		

BILL OF MATERIALS

DEPT	NAME	SIGN	DATE
DRN	ARUN KUMAR		10.11.19
CHD	ASHISH KUSH.		10.11.19
APPD	V.KESAVAN		10.11.19

TITLE:  
 GA DRAWING OF RUBBER EXPANSION JOINT

DRG .NO:

SCALE : NTS  
 REV NO  
 00

**Quality Assurance (Mech)**  
**CONTRACT QUALITY REQUIREMENT (CQR)**

MPLG: FGD: REJ: 647

Dt. 27-12-2022

PROJECT	INDENT NO	INDENT DATE	PGMA	TECHNICAL SPECIFICATION
RAMAGUNDEM,NABI-660MW, BHUSAWAL,NABI-250MW,NSPCL BHILAI,BONGAIGAON,PATRATU	Q85127752	16.12.2022	FW223	FWQS 024:R02,DT:30.10.2022

ITEM NAME: RUBBER EXPANSION JOINT

1. All the items shall be inspected at Manufacturer works as per BHEL QP/ Approved Drawing/Approved datasheet and Technical Specification.
2. Physical Inspection shall be done by BHEL/BHEL AIA at Manufacturer works.
3. BHEL Approved source is acceptable for NTPC Projects and for BHUSAWAL Projects commercial project coordinator may be contacted for vendor acceptance if any.
4. Arrange Vendor acceptance for BHEL QP (EXP JOINT: 392/02, DT: 09.02.2022) with their duly sign and seal.
5. NTPC or Any other Customer latest approved QP if any for similar application available with vendor may be shared on Vendor specific.
6. Packing of items shall be as per BHEL Engg Approved Packing Drawing/Technical Specifications.
7. BHEL Authorized representatives shall have the right to witness the necessary inspection and testing of goods mentioned in the PO. The supplier shall inform BHEL in advance about the readiness of the goods for inspection and testing. Inspection / Inspection wavier / approval by BHEL does not absolve Supplier's responsibility for conformity of the specification as per the terms of PO. Material Test Certificates shall be submitted to BHEL.
8. Annexure 'Q' shall be part of enquiry File and shall be filled by Supplier with their duly sign and seal.
9. **General Inspection Notes:**
  - a. Latest version of standards & Specification shall be applied.
  - b. Materials shall be procured in compliance to Functional Technical specification.
  - c. Gauges and measuring instruments with valid calibration only shall be used.
  - d. Inspection / Inspection wavier / approval by BHEL does not absolve Supplier's responsibility for conformity of the specification as per the terms of PO.
  - e. BHEL /BHEL Authorized representatives shall have the right to witness the necessary inspection and testing of goods mentioned in the PO.
  - f. In case of Vendor Drawing & Datasheet, it needs approval by BHEL Engineering.
  - g. This QP shall be read along with relevant PO, BHEL Specification / Approved Drawing/Datasheet.

This is for your information and further necessary action at your end please.

Sd\ - Rakesh Kr Madhu  
Dy/Mgr-QA



Sd\ - K Renjith  
Mgr/QA

1224397/2022/BAP/QA MECH

 Ranipet	MANUFACTURER'S NAME & ADDRESS BHEL/ BHEL APPROVED SOURCE	<b>STANDARD QUALITY PLAN</b> ITEM: RUBBER EXPANSION JOINT QP. NO.: EXPANSION JOINT :392 Rev No. :02 Date: 09.02.2022 Page 1 of 3	PROJECT: AS PER PO.
---	---	---	---------------------

SL NO	COMPONENT & OPERATION	CHARACTERISTICS	CLASS OF CHECK	TYPE OF CHECK	QUANTUM OF CHECK		REFERENCE DOCUMENTS	ACCEPTANCE NORMS	FORMAT OF RECORD		Agency			REMARKS
					M	B/C			M	B	C			
1	2	3	4	5	M	B/C	7	8	9	D	10	11		



1.0 RAW MATERIALS *														
1.1	Polymer Identification	Physical Properties	Major	Qualitative Analysis /Testing	1 Sample/ Lot /Melt / Heat	1 Sample/ Lot/Melt /Heat	BHEL Spec. / Approved Drawing	Presence of Butyl Rubber	Test Certificate.	√	P	V	-	(*As per Tech Spec/ Approved Drawing/ Data sheet)
1.2	Rubber (Physical Properties)	a) Tensile Strength	Major	Testing	1 Sample/ Lot /Melt / Heat	1 Sample/ Lot/Melt /Heat	Approved Drawing / Data sheet	Approved Drawing/ Data sheet	Test Report	√	P	V	-	
		b) Elongation at Break	Major	Testing	1 Sample/ Lot /Melt / Heat	1 Sample/ Lot /Melt / Heat	Approved Drawing / Data sheet	Approved Drawing / Data sheet	Test Report	√	P	V	-	
		c) Shore Hardness	Major	Test	1 Sample/Lot /Melt / Heat		ASTM D-2240	65±5° Sh.A ( As per Relevant Std)	Test Report	√	P	V	-	
1.3	EPDM Rubber	a) Tensile Strength	Major	Testing	1 Sample/ Lot /Melt / Heat	1 Sample/ Lot /Melt / Heat	ASTM D-412	Minimum 80Kg/cm2	Test Report	√	P	V	-	
		b) Elongation at Break	Major	Testing	1 Sample/ Lot /Melt / Heat	1 Sample/ Lot /Melt / Heat	ASTM D-412	Minimum 250%	Test Report	√	P	V	-	
		c) Shore Hardness	Major	Measurement	1 Sample/Lot /Melt / Heat		ASTM D-2240	65±5° Sh.A	Test Report	√	P	V	-	

Manufacturer Name	<b>Legends:</b> M – Manufacturer / Subcontractor, B - BHEL /BHEL Authorized Inspection Agency, C - Customer, P - perform, V - Verification of reports W - Witness, TC - Test certificate "D" – Record, identified with tick (√) shall be essentially included by Supplier in QA documentation.	Prepared by	Reviewed and Approved by
Sign & Stamp with Date		 Rakesh Kr Madhu (Dy Manager / QA)	 K Renjith (Manager / QA)

1224397/2022/BAP/QA MECH

 Ranipet		MANUFACTURER'S NAME & ADDRESS BHEL/ BHEL APPROVED SOURCE		<b>STANDARD QUALITY PLAN</b>				PROJECT: AS PER PO.																	
		<b>ITEM:</b> RUBBER EXPANSION JOINT		<b>QP. NO.:</b> EXPANSION JOINT :392 <b>Rev No. :</b> 02 <b>Date:</b> 09.02.2022 <b>Page 2 of 3</b>		SL NO		COMPONENT & OPERATION		CHARACTERISTICS		CLASS OF CHECK		TYPE OF CHECK		QUANTUM OF CHECK 6		REFERENCE DOCUMENTS		ACCEPTANCE NORMS		FORMAT OF RECORD		Agency M   B   C	
1		2		3		4		5		M		B/C		7		8		9		D		10		11	

1.4	Metal Flange & Stretcher Olate	Chem. & Mech. Test ( Tensile, Elongation, at Break and Yield strength)	Major	Testing	1 Sample for Entire Supply	ASTM A36	ASTM A36	Test Certificates	√	P	V	-	
1.5	Control Rods	DO	Major	Testing	1 Sample/Lot /Melt / Heat	ASTM A 307 Gr.-B	ASTM A307 Gr.-B	Test Certificates	√	P	V	-	
1.6	Nut & Lock Nut	Chem. & Mech. Properties ( Hardness & Proof Load)	Major	Profile Inspection (Reduced Scope)	1 Sample/Lot /Melt / Heat	ASTM A307B + GAL+50μ / BHEL Spec. / Drawing		Test Certificates	√	P	V	-	
1.7	Final Product	Rubber Bellows Visual & Dimensional Conformity	Major	Measurement	1 Sample/Lot /Melt / Heat	As per Approved Drawing	As per Approved Drawing	Report	√	P	V	-	
2.0	<b>FINAL INSPECTION</b>												
2.1	Hydrostatic Test	Hydro test	Major	Testing	1 Sample/Lot /Melt / Heat	As per Approved./ Drawing/Data sheet	No Leakage	Test Report	√	P	W	-	<b>Duration of Hydro test shall be 10 Minutes</b>
2.2	Deflection Check	Deflection Test	Major	Testing in Axial Compression by 10 mm.	1 Sample/Lot /Melt / Heat	Technical Specification/ As per Approved./ Drawing/Data sheet/ Relevant Standard	Technical Specification/ As per Approved./ Drawing/Data sheet/ Relevant Standard	Test Report	√	P	W	-	<b>Duration of all the Deflection Test shall be 2 minutes.</b>
				In Axial Elongation by 10 mm.				Test Report	√	P	W	-	
				Lateral Deflection by 10 mm				Test Report	√	P	W	-	
3.0	<b>PACKING &amp; PRESERVATION</b>												

Manufacturer Name		<b>Legends:</b> M – Manufacturer / Subcontractor, B - BHEL /BHEL Authorized Inspection Agency, C - Customer, P - perform, V - Verification of reports W - Witness, TC - Test certificate "D" – Record, identified with tick (√) shall be essentially included by Supplier in QA documentation.	Prepared by		Reviewed and Approved by	
Sign & Stamp with Date			 Rakesh Kr Madhu (Dy Manager / QA)		 K Renjith (Manager / QA)	

1224397/2022/BAP/QA MECH



 Ranipet		MANUFACTURER'S NAME & ADDRESS BHEL/ BHEL APPROVED SOURCE		<b>STANDARD QUALITY PLAN</b>				PROJECT: AS PER PO.																	
		<b>ITEM:</b> RUBBER EXPANSION JOINT		<b>QP. NO.:</b> EXPANSION JOINT :392 <b>Rev No. :</b> 02 <b>Date:</b> 09.02.2022 <b>Page 3 of 3</b>		SL NO		COMPONENT & OPERATION		CHARACTERISTICS		CLASS OF CHECK		TYPE OF CHECK		QUANTUM OF CHECK 6		REFERENCE DOCUMENTS		ACCEPTANCE NORMS		FORMAT OF RECORD		Agency M   B   C	
1		2		3		4		5		M		B/C		7		8		9		D		10		11	

3.1	Packing	Verification	Major	Verification of packing	100%	100%	Plant procedure and Packing	PO/Specificat ion/ Drawing	Paint and packing Report	√	P	V	-	
-----	---------	--------------	-------	-------------------------	------	------	-----------------------------	----------------------------	--------------------------	---	---	---	---	--

Notes: a. Latest version of standards & Specification shall be applied.  
 b. Materials shall be procured in compliance to Functional Technical specification.  
 c. Gauges and measuring instruments with valid calibration only shall be used.  
 d. Inspection / Inspection wavier / approval by BHEL does not absolve Supplier's responsibility for conformity of the specification as per the terms of PO.  
 e. BHEL /BHEL Authorized representatives shall have the right to witness the necessary inspection and testing of goods mentioned in the PO.  
 f. In case of Vendor Drawing & Datasheet, it needs approval by BHEL Engineering.  
 g. This QP shall be read along with relevant PO, BHEL Specification / Approved Drawing/Datasheet.

### RECORD OF REVISION

REV NO	DATE	DESCRIPTION
00	04.02.2020	Original Issue – First submission
01	05.02.2020	Revised based on feedback from QC-proc.
02	09.02.2022	QP Class 1.1 updated.

Manufacturer Name		<b>Legends:</b> M – Manufacturer / Subcontractor, B - BHEL /BHEL Authorized Inspection Agency, C - Customer, P - perform, V - Verification of reports W - Witness, TC - Test certificate "D" – Record, identified with tick (√) shall be essentially included by Supplier in QA documentation.	Prepared by		Reviewed and Approved by	
Sign & Stamp with Date						
		Rakesh Kr Madhu (Dy Manager / QA)		K Renjith (Manager / QA)		

## Annexure Q

Indent No:		Enquiry no:	
Sl.No	BHEL / Customer Requirements	## Specific confirmations by the manufacturer (Acceptable/Not acceptable)	
	<b>Quality Plan Requirement: (If SQP is not given &amp; Vendor QP applicable)</b>		
	(i) MQP (Manufacturing Quality Plan) shall be submitted in attached format for BHEL/Customer review & approval. Our SQP/Typical MQP/ MQP Format is attached for guidance & use.		
	(ii) MQP shall invariably cover w.r.t Inward inspection including on Raw material Procurement, In process and Final inspection in elaborated way/details.		
	(iii) Bidder shall also to give specific confirmation that on need basis, their competent officials shall visit to BHEL / customer for finalization of Quality plan including test procedure/methodology during preaward / post award approval / detailed engineering in the event of an order.		
	(iv) No deviation on BHEL/Customer approved MQP/ SQP (In case BHEL SQP is provided) is acceptable.		
1	(v) Bidder shall agree to submit all cross referred documents other than codes/standards to BHEL/Customer/Consultant.		
	<b>Important Notes shall be included in MQP :</b> (a) Latest revision of Standard s & Specification shall apply. Only International Standards are applicable. (b) Materials shall be procured in compliance to Functional Technical Specification. (c) Inspection shall be in compliance with Approved Quality Control Procedure for the Product. (d) NDT shall be carried out by Qualified Personnel with compliance to Approved NDT Procedures and Acceptance Norms, as per ASME standard. (e) Gauges and measuring Instruments, with valid calibration only shall be used. (f) Cleaning and Painting of products shall be carried out as per Approved Painting Schedule. (g) Finished Products shall be packed to comply with Approved Packing Schedule. (h) Welding shall be carried out by Qualified Personnel with compliance to Approved NDT Procedures and Acceptance Norms, as per ASME standard.		
2	<b>Domestic / Inland Inspection</b> will be carried out by BHEL/BHEL appointed Third Party Inspection Agency (TPIA) / Customer/Customer Appointed Inspection Agency/Consultant. This is applicable for all Stage inspection and Final Inspection identified as "W" - Witness or "CHP" - Customer Hold Point as per customer approved Quality Plan/ Technical specification / Approved Drawing/ Approved Data sheet / Scheme / PID / PFD / SLD (Process Instrumentation Diagram / Process Flow Diagram / Single Line Diagram) etc. (as applicable).		
3	<b>Inspection Agency for Foreign Bidders and also for Indian Bidder but importing from Foreign Sources:</b> (1) Any one of the following Third Party Inspection Agency (TPIA) shall be appointed by the bidder and same shall be furnished by the bidder in techno commercial bid itself. (2) The details of TPIA with contact details like Name of the official, Phone no, Email id shall also to be submitted during pre/post award. However cost for such inspection agency shall be borne by the bidder only. Inspection charges for such inspection agency shall be indicated separately so that if BHEL/Customer is undertaking the inspection by on their own , then these charges are non claimable by the bidder. For NTPC Project ensure TPI Approved by NTPC. Refer our QC Procurement email in this regard. <b>List of TPIA</b> 1.M/s Bureau Veritas 2.M/s TUV-Nord 3.M/s TUV-SUD 4.M/s TUV Rheinland 5.M/s Lloyds Register 6.M/s SGS 7.M/s Germanischer Lloyds 8.M/s QUEST 9.M/s Certification Engineers International 10.M/s Intertek 11.M/s IR Class Systems and Solutions 12.M/s DNV 13. M/s Fichtner 14. M/s ABS Inspection Services		

1224397/2022/BAP-QA\_MECH

Sl.No	BHEL / Customer Requirements	## Specific confirmations by the manufacturer (Acceptable/Not acceptable)
4	<b>Stage Inspection during manufacturing Process</b> : Stage Inspection during manufacturing shall be carried out as per approved quality plan and all necessary documents shall be provided for review, verification and clearance for further processing. This inspection call shall be given well in advance (at least 2 weeks before) to TPI/Bidder's own inspection agency to avoid delay in the manufacturing processes.	
5	<b>Inspection before despatch for domestic supplier</b> : Inspection before despatch at supplier's works shall be carried out by BHEL appointed Inspection agency (as in Sl no. 2). Inspection shall be done as per approved Quality plan/ Technical specification/ Approved Drawing/ Approved Data sheet .	
6	<b>Inspection at Foreign Source/Supplier:</b> (a) As in sl no: 3. shall be ensured without fail (b) No material / items shall be despatched without getting the written communication from BHEL / Customer inspection carried out by Bidder appointed Third Party Inspection Agency (As per Sl no.3) / Customer/Customer Appointed Inspection Agency/Consultant. This is applicable for all Stage inspection and Final Inspection identified as "W" - Witness or "CHP" - Customer Hold Point as per customer approved Quality Plan/ Technical specification / Approved Drawing/ Approved Data sheet / Scheme / PID / PFD / SLD (Process Instrumentation Diagram / Process Flow Diagram / Single Line Diagram) etc. (As applicable). Inspection before despatch for Foreign supplier : Inspection before despatch at supplier's works shall be carried out by bidder appointed inspection agencies having international presence at vendors and or vendor's sub vendor works. Inspection shall be done as per approved Quality plan/ Technical specification/ Approved Drawing/ Approved Data sheet by TPIA mentioned in Sl no: 03 at supplier's cost.	
7	<b>Painting</b> shall be done strictly as per BHEL/Customer approved painting schedule / scheme only. Paint Thickness / Paint shade shall be ensured as per BHEL / Customer approved painting schedule / specification / data sheet etc. No deviation is acceptable unless otherwise accepted by BHEL/Customer in writing. Any conflict if any among BHEL / Customer approved painting schedule / Spec / data sheet etc. shall be brought to the notice of BHEL well in advance before proceeding including the BOI being procured for assy / skid like motors etc.	
8	Specific conformation for document package in the event of an order (2 Hard copies & soft copy in PDF file) is to be given containing the following with proper linkages (i) Index Sheet (ii) MQP/RQP/Endorsement Sheet (As applicable) (iii) TCs identified by BHEL/ Customer for record for "CHP" / "W" and Verification portion ("V") as given in approved QP. (iv) Final inspection report + TC including Chemical + Mechanical + HT + NDT etc. (v) Third party Inspection report + TC (vi) Customer CHP/ MDCC (vii) Type test / Performance Test reports conducted (viii) Type test / Performance Test approval/ clearance obtained from BHEL/Customer (ix) BOM with As Build Drgs with actual make / rating used with BHEL/customer approved drawings.	
9	<b>Packing / Seaworthy Packing</b> shall be as per BHEL Packing schedule / approved drg / sketch. This shall be ensured to take care transit / handling / transshipment in Road / Sea / Air. Photographs are to be submitted for BHEL review before despatching the material as per contract conditions.	
10	<b>Outsourcing of test facilities:</b> Bidder shall ensure all the testing facilities in house. However If any of the test facilities are not available with successful bidder, then bidder shall ensure the same at NABL accredited third party lab / Govt / Govt Lab for major testing such as NDT, Electrical & Mechanical testing.	
11	<b>Important Note:</b> No deviation on the above requirement 01 to 10 is acceptable with respect to Quality Requirement and those offers not meeting these specific customer requirement is liable for rejection and hence the bidder shall submit all the required documentary evidences in the offer itself.	
12	## Necessarily to be filled up by the bidder at the time of offer itself otherwise the offer may not be considered w.r.t Quality Requirement being customer specific requirement.	

VENDOR SIGN AND STAMP:

Vendor Name &amp; Address:

\*(To be submitted In the company letter head by supplier)

## **Form - 1**

**Subject:** Public Procurement (Preference to Make In india)

**References:**

- 1.P-45021/2/2017-B.E-II dated. 15<sup>th</sup> June-2017,
- 2.P-45021/2/2017-PP(BE-II) dated. 28<sup>th</sup> May-2018 ,
- 3.P-45021/2/2017-PP(BE-II) dated. 29<sup>th</sup> May-2019.
- 4.P-45021/2/2017-PP(BE-II) dated. 4<sup>th</sup> June-2020

We hereby declare with reference to above subject and references that M/s -----(Tick whichever is applicable as below)

"Class-I local supplier" meeting the requirement of minimum local content equal to 50%(fifty percent) or more defined in the above government notification for the goods and services (or)

"Class-II local Supplier" meeting the requirement of local content 20% to less than 50%(fifty percent) defined in the above government notification for the goods and services

Please mention the details against the following:

Enquiry no:----- dated. -----

Type of Supplier (Class-I/Class-II) .....

Product:-----

Project:.....

Details of location at which local value addition will be made is as follows:

---

We also understand that the false declarations will be in breach of the code of Integrity under rule 175(1)(i)(h) of the General financial rules for which a bidder or its successors can be debarred for up to two years as per Rule 151(iii) of the General Financial Rules along with such other actions as may be permissible under law.

Authorized Signature M/s \_\_\_\_\_

(Signature and seal)

Place:.....

Date:.....

From.

M/s \_\_\_\_\_

Address: \_\_\_\_\_

**Note:** For offer value INR 10 crores or more, shall be vetted/endorsed by statutory auditor or cost auditor, for the declared local content.

**\*(To be submitted In the company letter head by supplier)**

## **Form – 2**

I/we are bidder from \_\_\_\_\_ (Address with country). We do not belong to any of the below category mentioned.

1. Any of entity/office/workshop of your organisation/incorporation, established in a country sharing land border with India, If yes, provide the full address of all such locations.
2. Any of subsidiary of your organisation/incorporation, established in a country sharing land border with India, If yes, provide the full address of all such locations.
3. Any of entity/office/workshop of your organisation/incorporation, controlled in a country sharing land border with India, If yes, provide the full address of all such locations.
4. Any of entity whose beneficial owner is situated in a country sharing land border with India, If yes, provide the full name, address of all such locations.
5. Any Indian Agent available, If so, Provide details of address and contacts.
6. Any employee/directors who is/are citizen of country sharing land border with India, If yes, provide the full name, employee code and address of all such locations.
7. Any of consortium/joint venture of your organisation/incorporation, established in a country sharing land border with India, If yes, provide the full address of all such locations.

### **Meaning of beneficial owner**

- 1) In case of a company or limited liability partnership, beneficial owner is the natural person, who, whether acting alone or together, or through one or more judicial person, has a controlling ownership interest or who exercises control through other means.

### **Explanation**

- a) Controlling ownership interest means ownership of or entitlement to more than twenty-five percent of shares or capital or profits of the company.
  - b) “control” shall include the right to appoint majority of the directors or to control the management rights or shareholder’s agreement or voting agreement.
- 2) In case or a partnership firm the beneficial owner is the natural person (s) who whether acting alone or together or through one or more judicial person, has ownership of the entitlement to more than fifteen percent of capital or profits of the partnership.
  - 3) In case of an unincorporated association or body of individuals, the beneficial owner is the natural person(s), who, whether acting alone or together or through one or more judicial person, has ownership of the entitlement to more than fifteen percent of the property or capital or [profits of such association or body of individual.
  - 4) Where no natural person is identified under (1) or (2) or (3) above, the beneficial owner is the relevant natural person who holds the position of senior managing official.
  - 5) In case of a trust, the identification of beneficial owner (s) shall include identification of the author of the trust, the trustee, the beneficiaries with fifteen percent or more interest in the trust and any other natural person exercising ultimate effective control over the trust and any other

**\*(To be submitted In the company letter head by supplier)**

natural person exercising the ultimate effective control over the trust through a chain of control of ownership.

- 6) An agent is a person employed to do any act for another, or to represent another in dealing with third person.

We have read the clause regarding restriction on procurement from a bidder of a country which shares a land border with India, we hereby declare that we do not belongs to any such country and are eligible to be considered.

In case, any of information is found to be false, even after bid acceptance, immediate termination may happen and action will be taken as per law.

Format is being filled without altering any of the clause mentioned in the given format\*\*

Dated: \_\_\_\_\_

Authorised Sign and stamp\_\_\_\_\_