



TECHNICAL SPECIFICATION OF FGD ABSORBER AGITATORS

TRY/PE-BM/FGD/AGITATOR SPEC:001/ Rev 01





BHARAT HEAVY ELECTRICALS LIMITED
(A GOVT OF INDIA UNDERTAKING)

BOILER MOUNTING–PRODUCT ENGG(FB)
BHEL -TRICHY

TECHNICAL SPECIFICATION OF FGD ABSORBER AGITATORS

SPECIFICATION NO : TRY/PE-BM/FGD/AGITATOR SPEC:001/REV 01
BUYER (EPC) : BHEL
APPLICATION : WET LIMESTONE FGD

01	28-03-2022	General Revision	 Sathiesh Kumar S Manager PE / FB (BM)	 R Gopinath Manager PE / FB (BM)	 V. Gunasekaran DGM PE / FB (BM)
00	01-07-2021	Fresh Release	Sathiesh Kumar S	R Gopinath	V. Gunasekaran
REV	Date	Description	Prepared	Checked	Approved

This document is meant for the exclusive purpose of bidding against this specification and shall not be transferred, reproduced or otherwise used for purposes other than that for which it is specifically issued.



TECHNICAL SPECIFICATION OF FGD ABSORBER AGITATORS

TRY/PE-BM/FGD/AGITATOR SPEC:001/ Rev 01

I) DOCUMENTS TO BE SUBMITTED ALONG WITH THE OFFER:

Sl. No	Description	Offer part	Purpose
1.	Documents for meeting the Pre-Qualification Requirement as per Annexure-X has to be submitted along with supporting documents	Part -1	Qualification requirement for considering the offer
2.	Reference list – Annexure-I	Part -1	Qualification requirement for considering the offer
3.	Compliance to the Agitator and Motor Technical Specification with all Annexures.	Part-1	Technical evaluation
4.	Compliance to the Agitator Indicative MQP (Annexure-VIII) & CQR for LT Motors if Applicable (Annexure-IX)	Part -1	Technical evaluation
5.	GA drawing, Exploded view with Material of construction, total weight of all Agitators models offered	Part -1	Technical evaluation
6.	Schedule of Guarantees (Annexure-V) specific to the Enquiry	Part -1	Technical evaluation
7.	List of Deviations (Annexure-VI)	Part -1	Technical evaluation
8.	Duly filled, Mandatory Spare list (Annexure-XI)	Part -1	Technical evaluation
9.	Motor vendor list and mechanical seal vendor list	Part -1	Technical evaluation
10.	Start-up & Commissioning Spares	Part -1	Technical evaluation
11.	List of Special Tools	Part -1	Technical evaluation
12.	Catalogue	Part -1	Technical evaluation
13.	Duly filled Annexure –XII , FGD ABSORBER AGITATOR Checklist Cum Datasheet . All the documents and data as mentioned in the Annexure-XII shall be submitted by bidder for evaluation, else the offer is liable for technical rejection	Part -1	Technical evaluation



TECHNICAL SPECIFICATION OF FGD ABSORBER AGITATORS

TRY/PE-BM/FGD/AGITATOR SPEC:001/ Rev 01

II) DOCUMENTS TO BE SUBMITTED AFTER CONTRACT:

Sl. No.	Description	Purpose	Delivery Time
1.	GA drawing, Exploded view, sectional view with Material of construction, mechanical seal, gearbox for all Agitator models	END CUSTOMER/BHEL approval to start manufacturing	2 week
2.	Data sheet for all Agitator	END CUSTOMER/BHEL approval to start	2 week
3.	Agitator Performance curve of all Agitators	END CUSTOMER/BHEL approval to start	2 week
4.	Electrical motor GA drawing & Data sheet and performance curves of all motors	END CUSTOMER/BHEL approval to start manufacturing	2 week
5.	Quality plan & Inspection and Test Procedure	END CUSTOMER/BHEL approval for inspection	2 month after contract
6.	Agitator and Motor Sizing Calculation (Annexure-III)	END CUSTOMER/BHEL approval to start	2 week
7.	Bending moment and Shaft design calculation	END CUSTOMER/BHEL approval to start manufacturing	2 week
8.	GA, BOM and Technical details of Emergency Flush Pipe with Flanges and Blind Flange	END CUSTOMER/BHEL approval to start manufacturing	2 week
9.	GA, BOM and Technical details of Agitator Nozzles and Emergency Flush Pipe Nozzles GA, BOM and Technical details	For Fabrication	2 week
10.	Utility Consumption	To arrange utility	2 week
11.	Foundation Data including Anchor plan	To civil design	2 week
12.	Lubricating oil list	Record purpose	4 week
13.	Special tools list	For maintenance	4 week
14.	Installation and assembly procedure	For erection	4 week
15.	Approximate weight of each skid	To arrange lifting device	4 week
16.	Pre Commissioning Check List	For erection	4 week
17.	Operation and Maintenance Manual	For O&M	4 week
18.	Start-up & Commissioning Spares	For commissioning	4 week
19.	List of Special Tools	For arranging	4 week
20.	P & I Diagram (if applicable)	For information	4 week



TECHNICAL SPECIFICATION OF FGD ABSORBER AGITATORS

TRY/PE-BM/FGD/AGITATOR SPEC:001/ Rev 01

CONTENTS:

MAIN SUPPLY	
1.0	APPLICABLE CODES & REGULATIONS
2.0	INTENT OF SPECIFICATION
3.0	PROVENNESS CRITERIA / QUALIFICATION REQUIREMENTS
4.0	MATERIAL OF CONSTRUCTION
5.0	SCOPE OF SUPPLY
6.0	GENERAL REQUIREMENTS
7.0	PACKING & FORWARDING
8.0	SUPERVISION OF ERECTION, TESTING & COMMISSIONING
9.0	EXCLUSION
10.0	INSPECTION, TESTING AND QUALITY REQUIREMENTS
11.0	PAINTING
12.0	SPARES, TOOLS & TACKLES
13.0	PERFORMANCE GUARANTEE
14.0	BID EVALUATION CRITERIA FOR POWER CONSUMPTION
15.0	LIQUIDATED DAMAGES FOR POWER CONSUMPTION
16.0	WARRANTY / DEFECT LIABILITY
17.0	FIRST FILL OF CONSUMABLES
18.0	TRAINING
19.0	DELIVERY CONDITION
20.0	DOCUMENTATION



TECHNICAL SPECIFICATION OF FGD ABSORBER AGITATORS

TRY/PE-BM/FGD/AGITATOR SPEC:001/ Rev 01

1.0 APPLICABLE CODES & REGULATIONS

The design and materials shall conform to the requirements of applicable codes and regulations of the latest edition. The design, manufacture, installation and testing of the Agitator shall follow the latest applicable Indian/International (AISI / ASME/EN/Japanese) Standards.

2.0 INTENT OF SPECIFICATION

This specification covers the minimum requirements for the complete design, material, manufacturing, shop inspection, testing at the manufacturer's works, supervision of erection & performance testing at bidder's works/ site of Agitators along with accessories which is furnished in the Flue Gas Desulfurization plant for END CUSTOMER Project. The following points have to be noted.

- a. Agitators are envisaged in FGD Absorber.
- b. Bidder shall assume full unit responsibility for the entire equipment assembly and make all possible efforts to comply strictly with the requirements of this specification and other specifications/attachments to inquiry/order.
- c. The Bidder shall offer only proven design which meets the Provenness /Pre-qualification requirement of END CUSTOMER. Necessary document evidences as per **Annexure-X for qualification** shall be submitted along with the bid. If bidder doesn't meet the specified Provenness criteria, their offer will be rejected.
- d. In case, deviations are considered essential by the Bidder (after exhausting all possible efforts), the same shall be separately listed in the Bidder's proposal under separate section, titled as "List of Deviations/Exceptions to the Enquiry Document (**ANNEXURE VI- LIST OF DEVIATIONS OR EXCEPTIONS TO THE ENQUIRY DOCUMENT**)
- e. Any deviation, not listed under the above section, even if reflected in any other portion of the proposal, shall not be considered applicable.
- f. No deviation or exception shall be permitted without the written approval of the purchaser.
- g. Compliance to this specification shall not relieve the Bidder of the responsibility of furnishing equipment and accessories/auxiliaries of proper design, materials and workmanship to meet the specified start up and operating conditions.
- h. In case, the Bidder considers requirement of additional instrumentation, controls, safety devices and any other accessories/auxiliaries essential for safe and satisfactory operation of the equipment, the same shall be recommended along with reasons in a separate section and include the same in scope of supply.
- i. All accessories, items of work, though not indicated but required to make the system complete for its safe, efficient, reliable and trouble free operation and maintenance shall also be in supplier's scope unless specifically excluded.

3.0 PROVENNESS CRITERIA/PRE-QUALIFICATION REQUIREMENT:

The Bidders are required to meet the Pre-Qualification Requirement (PQR) for Agitators as per the Provenness Criteria & shall submit the credentials as called in **Annexure-X. Only Manufacturers qualifying as per the Qualification requirement shall be considered for placement order.**

4.0 POWER SUPPLY DETAILS:

Refer Clause 5.3 for details.



TECHNICAL SPECIFICATION OF FGD ABSORBER AGITATORS

TRY/PE-BM/FGD/AGITATOR SPEC:001/ Rev 01

5.0 SCOPE OF SUPPLY

Scope for the bidders shall include Design, Manufacturing, Supply, and Supervision of Erection & Commissioning

Design: Includes basic engineering, detail engineering, preparation and submission of engineering drawings/calculations/datasheets/quality assurance documents/field quality plans, storage instructions, commissioning procedures, operation & maintenance manuals, performance guarantee test procedures and assisting BHEL in obtaining time bound approval from END CUSTOMER.

Supply: Includes manufacturing/fabrication, shop floor testing, stage inspections, final inspections, painting & packing.

Supervision of Erection & commissioning: Includes supervision of erection & commissioning, supervision of trial operation, training of customer's O&M Personnel.

Scope of bidder	
AGITATOR ASSEMBLY complete with	
i.	AGITATOR Blades
ii.	AGITATOR Shafts
iii.	Coupling arrangement (Flexible)
iv.	Single Mechanical Seals
v.	Shaft Sleeve
vi.	Lanterns/ Stools (Bearing Housing), Safety Guard
vii.	Bearings
viii.	Agitator Mounting Flanges with gaskets and fasteners
ix.	Drive Motor(IE3) with gearbox / belt and pulley arrangement
x.	Supporting arrangement of Side Entry Agitator on the tank Wall.
xii.	Supply of Agitator Vessel Nozzle and Emergency Flush Pipe Nozzle shall be in BHEL Scope, however bidder to provide complete documents like Nozzle General Arrangement with Sectional & Plan views, BOM, Shop Manufacturing/Fabrication drawing, Procedure, Material Cutting Plan drawings indicating all required dimensions and sizes for Manufacturing/Fabrication of Agitator Vessel & Emergency Flush Pipe Nozzles. Any technical support required for Manufacturing/Fabrication of Nozzles shall be extended by bidder post order stage.
xiii.	Agitator end mating flange, gaskets, fasteners and all other accessories for mounting agitator on the Agitator Vessel Nozzle shall be in bidder scope.
xiii.	Emergency Flushing system for startup consisting of Pipe with Flange, Nozzle mating flange, Blind flange for plugging, gaskets, fasteners and all other accessories required for completeness Emergency Flushing system shall be in bidder scope.
xiv.	Foundation plate with foundation bolts
xv.	Painting and Rust Prevention during shipment and construction
xvi.	Supervision of Erection & commissioning at site
xvii.	Conducting and Proving of Performance guarantee tests at site
xviii.	Special tools & tackles as applicable
xix.	Start-up spares as applicable
xx.	Installation, operation and maintenance manuals
xxi.	Any other items required for completeness of the equipment except the items covered in the exclusions.



TECHNICAL SPECIFICATION OF FGD ABSORBER AGITATORS

TRY/PE-BM/FGD/AGITATOR SPEC:001/ Rev 01

The scope of supply for AGITATORS shall include but not limited to the following:

5.1	TECHNICAL REQUIREMENTS
1.	Agitators shall be supplied in tanks and vessels to prevent caking and settlement of particles out of the slurry, e.g. in the absorber vessel.
2.	All agitators shall be designed for continuous operation unless otherwise specified. The design of the agitators shall be of proven type. CFD analysis, if required, shall be provided during detailed engineering or drawing approval stage at no extra cost.
3.	Standard type agitators with suitable characteristics shall be used wherever practical. The agitators shall be complete with motor, gearbox, agitator shaft, coupling, safety guards, mechanical seal (for side entry agitators), impeller, support legs, agitator mounting flange including bolts nuts and gasket etc.
4.	All agitator parts and accessories in contact with the stirred fluid shall be constructed of materials specifically designed for the conditions and nature of the stirred fluid and be resistant to erosion and corrosion.
5.	MOC of various agitator parts shall be as per “Technical Information for sizing of Absorber Agitators for respective project” . This does not release the bidder of the responsibility for selecting the correct materials. All parts which are in contact with slurry or in contact with slurry fumes shall be considered as wetted part. The material selected shall be suitable to the service conditions.
6.	Each agitator and its associated equipment shall be arranged in such a manner as to permit easy access for operation, maintenance and agitator removal without interrupting plant operation. It shall be possible to remove the sealing devices of the Agitators of the absorber vessel without having to drain completely the absorber.
7.	To prevent mechanical blocking load start-up after standstill of pumps, piping and agitators for slurries shall be applied with C-hose connection.
8.	Lifting lugs and eyes and other special tackle shall be provided as necessary to permit easy handling of the agitators and their components.
9.	Static and dynamic (as far as applicable) balancing of all agitators shall be carried out after assembly.
10.	All agitator parts and components shall be designed and calculated for fatigue life, considering maximum bending loads, induced by fluctuating hydraulic forces and torsional loads, based on the installed motor power. For side entry agitators the alternating bending moment resulting from impeller and shaft weight has to be considered additionally.
11.	All exposed moving parts shall be covered by guards.
12.	The shape of the impeller blades of side entry agitators shall be designed to avoid wear on the impellers which will affect the agitator performance as specified for a minimum period of 2 years of continuous operation under design conditions for the range of coal & limestone specified in the specification. In order to avoid excessive wear impeller tip speeds must not exceed 12 m/s
13.	Belt drives (if applicable) shall be properly designed to provide a minimum lifetime of 2 years under design conditions
14.	Clause Deleted.
15.	Maintaining a uniform concentration over the 95% of liquid column. Absolute sweeping of solid particle from tank bottom is a must for all Agitators. If speed is required to be increased to guarantee the above requirements; the same can be increased by vendor.



TECHNICAL SPECIFICATION OF FGD ABSORBER AGITATORS

TRY/PE-BM/FGD/AGITATOR SPEC:001/ Rev 01

16.	For Absorber, Auxiliary Tank and Drain Sump Agitators : There shall not be any slurry settlement at the Bottom of the Tank and all solids shall be suspended off the tank bottom (i.e. Off Bottom suspension)
17.	It is to be noted that in continuous process any deposit at tank bottom is the loss of material which are not getting converted as per process. Hence, total loss of material by sedimentation is a loss to FGD Process & determines the "In efficiency of the Agitator".
18.	Vendor should ensure nil settlement; utilization of solid material shall be a guaranteed parameter and will be assessed in percentage (%) term to net wet of solid mass of inflow or out flow. This is one of the guarantee parameter.
19.	Agitator and its driver shall perform on the test stand at shop and on the Agitator's permanent location at site within vibration limit the vibration of combined unit will be the responsibility of Agitator manufacturer. Agitator manufacturer is to ensure that Site performance of vibration is one of the "Acceptance Criteria" of the equipment. Please note vibration at test stand can only be taken as for information.
20.	Every Tank will have a pump whose suction line shall be connected to tank. These pumps are to operate continuously at the lowest operating level which is decided by Process requirement. Hence, the minimum operating level of liquid in every tank for every Agitator is a must to assess the combined operation of Agitator as well as that of pump alone. The Tank water level is indicated as per " Technical Information for sizing of Absorber Agitators ".
21.	Agitator must have low-pitch propeller with low solidity ratio and low Power Number. Power number shall be in the range of 0.3-0.35(preferably) or lower. The Maximum Input Power at motor terminal shall be considered as a guaranteed parameter under "Schedule of Guaranteed Parameters" in "Annexure-V-Schedule of Guarantees" and the same shall be calculated for maximum liquid level in tank. A calculation of power specifying the hydraulic power of Agitator, Seal loss, Gear box and Motor internal loss must be submitted along with the offer. A characteristics curve showing power versus liquid level should be submitted from the lowest liquid level, required for Agitator to maximum liquid level in the tank. Motor should be selected based on the highest power demand with a margin as per clause 5.3.2 at maximum liquid level as indicated in "Technical Information for sizing of Absorber Agitators", taking into account frequency variation.
22.	" Typical Arrangement of side entry agitator in absorber " drawing is provide with the specification wherein scope demarcation, height restriction of the agitator are indicated. Bidder to provide full compliance for this drawing with Signature and Seal.
5.2	CONSTRUCTIONAL FEATURES
A)	BLADE AND HUB OF PROPELLER
i)	The type of impeller shall be selected on the basis of suspended solids where the work is being performed. The selected profile shall be consistent with the specified operating conditions ,i.e., the type of tank, solid concentration etc.
ii)	It must be possible to remove the blades from their joining point. Each blade shall be made of one single piece.
iii)	The Blade design of the Agitator to be of most efficient design in order to offer least power consumption. The Agitator power consumption is part of the guarantee parameters.
iv)	Although Agitator will have substantial low speed because of reduction Gear Box, hydraulic unbalance at impeller can cause severe vibration, hence it is mandatory that rotating assembly shall be dynamically balanced to its rated speed.



TECHNICAL SPECIFICATION OF FGD ABSORBER AGITATORS

TRY/PE-BM/FGD/AGITATOR SPEC:001/ Rev 01

v)	Impeller should be dynamically balanced to Gr: G16: ISO-1940 after rubber lining of shaft.
B)	SEAL
I.	Agitators should be provided with Single Stage mechanical seal. the mechanical seal should be as per ISO-21049 / API 682.
II.	The wetted parts of the mechanical seal material shall be minimum "ASTM A240 SUPER DUPLEX 2507" and shall be suitable for the slurry service conditions.
III.	The Mechanical Seals shall be so arranged that repacking or fitting of replacement seals can be carried out with the minimum of disruption to plant operation.
IV.	Design the mechanical seals chamber to have sufficient room to lubricate and get seal face cool with its own slurry.
V.	Provide requirements for periodical flushing to rinse the seal face for leaked slurry.
VI.	All mechanical seals, regardless of type or arrangement, shall be of the cartridge design. Hook sleeve cartridge should not be used.
VII.	Requirement of flushing water, its quantity, and pressure to be indicated in data sheet.
VIII.	Zero leakage is the intension of this specification. However, quantity of leakage, if it is unavoidable, it should have a provision of collecting / or discharging back to the tank.
IX.	Mechanical seals shall be fitted and installed in the Agitator before shipment and shall be clean. Mechanical seals shall be plugged with screw for shipping.
X.	Intention of the specification is not to specify Type of Seal, Seal design, Spring configuration, Seal configuration, Balanced or Unbalance type etc. Agitator manufacturer to decide the same along with seal manufacturer the best seal that is suitable for the offered Agitator
XI.	Seal life has to be guaranteed, taking into consideration all its components for 25000 hrs. If the seals fail before the completion of guaranteed period, the same should be replaced free of cost by the bidder.
XII.	The sub-vendor of the seal shall be approved by END CUSTOMER during contract execution.
C)	SHAFT
	Use of dissimilar material at flange joint shall be avoided to eliminate any crevice corrosion. Spacing of the shaft joint should not be more than 3.0 m for easy assembly if it is more than 40kg. If welding is used for joining two tubes, welding joint must be 100% radio graphed. If split shaft is proposed for larger tanks , shaft flange at the joining interface has to be rubber lined at manufacturer's works and necessary fasteners have to be provided.
D)	BEARING & BEARING HOUSING IN GEAR BOX
I.	Bearing shall be of rolling type radial and thrust bearing (FAG/SKF make only) as required. Thrust bearing shall be sized for continuous operation under all specified condition.
II.	Thrust bearing shall provide full load capability if the Agitator's normal direction of rotation is reversed. Up-thrust and Down-thrust load must be taken into account in sizing bearing. Life of the every anti-friction bearing, used in the bearing housing as per manufacturer's design, should have L10 of 25000 hr. (minimum).



TECHNICAL SPECIFICATION OF FGD ABSORBER AGITATORS

TRY/PE-BM/FGD/AGITATOR SPEC:001/ Rev 01

III.	Bearing housing should be grease/oil lubricated. If bearing is oil lubricated, constant-level sight-feed oiler of 100cc size or bigger capacity is to be provided. Bearing housing should have oil drain, constant oil level indicator. A provision of one(1) number G1/2" thread (ISO-228, Part-1) port is required for remote control of temperature of bearing housing oil bath RTD.
IV.	If bearing housing requires cooling water, volume and pressure of cooling water is to be indicated in Technical Data Sheet.
V.	Lubricating oil will be the responsibility of Gear Box manufacturer. Hence, manufacturer has to make arrangement of first fill of oil at installation and at commissioning stage. Quantity of oil and its grade is to be indicated in Drawing and Operation Manual.
E)	MATERIALS
	Agitator components designated as "Full Compliance Material" shall meet the requirements of the industry specification as listed for the material in the " Technical Information for sizing of Absorber Agitators " as well as in the specification in the respective section.
F)	Driver (Motor)
I.	Driver shall be sized to meet all specified operating conditions including bearing housing, seal, external gear box and coupling loss(if any).
II.	Motor shall be able to accelerate to speed at reduced voltage and frequency as specified in "Site Power Supply Condition" as per Clause: 5.3.
III.	It should meet Motor specification enclosed (Refer clause 5.3 of the specification).
G)	GEAR BOX
	Complete up-thrust and down-thrust, developed by Agitator shall be taken by thrust bearing housing of Gear Box. Rating of at Gear box shall be at least 1.5 times the rated torque of Agitator.
H)	COUPLING & COUPLING GUARD
I.	Coupling and coupling guard should be supplied between driver and driven equipment.
II.	Coupling should be designed taking into consideration adequate service factor.
III.	Design rating of the coupling (excluding service factor) should be indicated in data sheet.
IV.	Coupling must be having locking screw so that it does not slide over shaft in due course operation.
V.	It is desirable that for servicing of seal, coupling half should not be removed. Coupling should be dynamically balanced to Gr: G6.3, ISO-1940.
VI.	Removable coupling guard shall conform to the requirements of all applicable national, industrial or statutory regulations.



TECHNICAL SPECIFICATION OF FGD ABSORBER AGITATORS

TRY/PE-BM/FGD/AGITATOR SPEC:001/ Rev 01

I)	PLATE AND FASTENING BOLTS
I.	Alignment between Gear Head Shaft and Agitator shaft shall be within the permissible limit of Gear Box. Similarly, misalignment between Motor shaft and Gear Box Shaft shall be within 0.050 micron (radial) and 2 degree (angular) or better as per requirement of Motor and Gear Box
II.	Clause Deleted
J)	OTHER COMPONENTS
	All fasteners used in wetted condition must be of alloy material or better material (bidder shall refer to the “Technical Information for sizing of Absorber Agitators” for details regarding the MOC of Wetted Fasteners) so that even if it comes in contact with liquid by swelling of rubber, thread remains unaffected. All fasteners provided inside the tank (even if it is exposed to the slurry vapour) shall be treated as wetted part only.
	GENERAL REQUIREMENT OF SIDE ENTRY AGITATORS:
I.	All Agitators shall be designed for continuous operation.
II.	The Material of Construction (MOC) of side entry Agitators shall be as per “Technical Information for sizing of Absorber Agitators” .
III.	It should be of Flange mounted type.
IV.	“Nozzle size” on which Agitator shall be mounted, shall have enough opening to Insert rotating assembly (i.e. impeller hub) from side.
V.	The Bidder to consider Gypsum Sedimentation during stoppage of Agitator.
VI.	<p>The following information to be provided along with the bid:</p> <ul style="list-style-type: none"> a) <u>Impeller Diameter</u> b) <u>Impeller Speed</u> c) <u>Agitator Pumping Capacity (m³/min)</u> d) <u>Volume per Agitator:</u> e) <u>Basis for selection of motor rating (calculation)</u> f) <u>Basis for selection of gear box, shaft, impeller etc.,</u>

5.3 MOTOR

1.	For Technical specification of LT AC Motors - Refer Annexure – VII
2.	Maximum continuous rating (MCR) of the motor shall have at least 20% margin over the maximum load demand of the driven equipment including voltage and frequency variation. <i>This clause shall supersede the clause “10.C” in the Technical specification of</i>



TECHNICAL SPECIFICATION OF FGD ABSORBER AGITATORS

TRY/PE-BM/FGD/AGITATOR SPEC:001/ Rev 01

LT AC Motors - Annexure – VII.

Guideline for minimum motor rating calculation of agitator is as below,

MINIMUM MOTOR RATING CALCULATION:

a. Calculated Volume of the Slurry Tank, $M^3 = \text{Width(M)} \times \text{Depth(M)} \times \text{Maximum liquid level in the tank(M)}$

For dimensions refer “*Technical Information for sizing of Absorber Agitators*”, for Width, Depth and Maximum liquid level in the tank.

b. Slurry Volume handled by each agitator = $\frac{\text{Calculated Volume of the Slurry Tank}}{\text{No: of agitator (i.e. 2 no's)}}$

c. Calculated Motor Rating = Slurry Volume handled by each agitator x 0.065 Kw.

Note: 0.065 Kw is the minimum motor rating per M^3 volume.

3. d. **Minimum Motor Rating = 20% margin over the Calculated Motor Rating (as per clause 5.3.2).**

Note: the above “Minimum Motor Rating” is the minimum design requirement, However Vendor may decide a higher motor rating based on the design and experience.

Calculation illustration with example:

Tank dimensions: - Width = 26.9M; Depth=10.9M; Max. liquid level in the tank=6M.

a. Calculated Volume of the Slurry Tank, $M^3 = 26.9 \times 10.9 \times 6 = 1759.26 M^3$.

b. Slurry Volume handled by each agitator = $\frac{1759.26}{2} = 879.63 M^3$

c. Calculated Motor Rating = $879.63 \times 0.065 = 57.19 Kw$.

d. **Minimum Motor Rating = 68.62 Kw (With 20% margin over 57.19Kw).**

6.0 GENERAL REQUIREMENTS:

S.No	Description
1.	Metric unit shall be used in the drawings and in the any displays on the equipment's. Special attention should be taken that the unit of pressure shall be in dual scales of kPa and kg/cm ² G. For instance the pressure gauges should have dual unit's indication.
2.	Descriptions in the drawings, in the documents, and in the displays shall be in English
3.	All rotating parts such as coupling shall be covered with suitable protective guards. Guards shall be



TECHNICAL SPECIFICATION OF FGD ABSORBER AGITATORS

TRY/PE-BM/FGD/AGITATOR SPEC:001/ Rev 01

S.No	Description
	easily removable type.
4.	The equipment shall be designed to withstand the corrosive and moist environment in which these are proposed to operate.
5.	Noise level produced by any rotating equipment individually or collectively shall not exceed 85 dB measured at a distance of 1.0 meters from the source in any direction and 1.5m above operating floor.
6.	The overall vibration level shall be as per ISO 10816.
7.	Suitable drain connections shall be provided.
8.	The equipment shall be suitable for stable operation continuously.
9.	Corrosion allowance: Corrosion allowance for entire equipment shall be in accordance with latest applicable Indian / International standard.
10.	Unless otherwise specified , flanges shall be in accordance with ANSI B16.5 Class 150
11.	Name plate: All equipment shall be provided with nameplates indicating the item number and service name. Name plates shall be of 304 Stainless steel plate and placed at a readily visible location. Nameplate of main equipment shall have enough information, which will be confirmed during engineering phase. Stainless steel nameplates for all instruments and valves shall be provided.
12.	Rotation arrows shall be cast in or attached with stainless steel plate on each item of rotation equipment at a readily visible location.
13.	Unless otherwise specified, all equipment items where the weight exceeds 15 kg shall be provided with suitable lifting lugs, ears or ring bolts or tapped holes for lifting rings. Minimum shock factor for lifting lugs shall be minimum 2.0. The position of lifting lugs and reference dimension shall be shown on GA and/or outline drawings. NDT shall be conducted for lifting lugs. When any spreader bars are required for lifting and laydown, the bidder shall provide spreader bar with equipment.
14.	Skid Mount/Transportation: Equipment shall be fabricated as skid mount design as much as practical to minimize erection at the site.
15.	If the driver/driven equipment train is in the resonance condition or any vibration problems occur, the bidder shall solve the problems in a timely manner.
16.	Bidder shall provide the necessary gaskets.
17.	All the surfaces of the carbon steel should be rust prevented before shipment for the period of at least 12 months for storage and construction.
18.	Bidder to provide capacity of crane or hoist required for material handling and the details of heaviest component to be handled.
19.	The list of all Bought out items with makes and country of origin to be mentioned along with offer to be submitted.



TECHNICAL SPECIFICATION OF FGD ABSORBER AGITATORS

TRY/PE-BM/FGD/AGITATOR SPEC:001/ Rev 01

S.No	Description
20.	Quality Plan to be submitted along with the offer.
21.	Cost towards the participation in discussions/meetings, providing technical assistance during technical discussions/meetings with customer for approval of drawing/documents etc. TA/DA, boarding and lodging to attend these meetings shall be borne by the bidder and shall be inclusive in supply portion.
22.	Material of construction for all equipment/components shall be subject to END CUSTOMER/ BHEL approval during detail engineering. Accordingly bidder shall consider MOC for all equipment/component as per best engineering practice, global standard and global references.
23.	Bidder to provide sub vendor list and Bidder shall strictly adhere to END CUSTOMER approved vendor list. In case bidder proposes an additional vendor for an item or vendor approval is required for any new item, acceptance shall be subject to approval by END CUSTOMER/ BHEL before placing order and bidder shall submit relevant documents to take up with END CUSTOMER for approval.
24.	It shall be the complete responsibility of the successful bidders to obtain "Sub Vendor Approval" from BHEL / END CUSTOMER for all equipment's & components. Any delay in sub vendor's approval should not affect the project schedule. If any of the sub vendors does not have the approval of END CUSTOMER/ BHEL, the same may be replaced with another END CUSTOMER/BHEL approved sub-vendor only, without any price implications to BHEL.
25.	<p>The modalities of inspection (Stage, Final, In-process) shall be finalized during detail engineering after submission of quality assurance plan (QAP). It shall be reviewed by the END CUSTOMER and BHEL. Bidder shall follow the procedures of inspection as per the approved QAP. Bidder has to submit the following documents along with inspection call and if any other documents required as per approved QAP.</p> <ul style="list-style-type: none">- Raw material inspection certificate- Internal test reports- Statutory certificates as required.- All inspection & testing shall be carried out based on the following documents:<ul style="list-style-type: none">a. Relevant Standardsb. Specificationsc. Approved drawingsd. Data Sheetse. Calibration certificate for all the measuring instrumentsf. Bidder should also coordinate in getting the MDCC's (Material Dispatch clearance certificate) and all types of IC's (Inspection Certificates) from the END CUSTOMER along with BHEL.
26.	During detail engineering, bidder to strictly adhere to BHEL/END CUSTOMER drawing formats, document numbering, quality plan & FQP formats
27.	The identification and numbering of equipment, systems, items, etc. of supply, as well as of all documents and drawings shall be in accordance with reference Designation System for Power Plants



TECHNICAL SPECIFICATION OF FGD ABSORBER AGITATORS

TRY/PE-BM/FGD/AGITATOR SPEC:001/ Rev 01

S.No	Description
	- KKS system.
28.	Complete detail engineering drawings, calculations, selection of components etc. shall be reviewed & subject to approval of BHEL/END CUSTOMER during detail engineering
29.	Bidder shall furnish necessary inputs & drawings of all equipment in editable Auto CAD/ MS-Word /Excel format.
30.	During detail engineering, successful bidder shall ensure flow of drawings/documents as per schedule. Any comments from BHEL/END CUSTOMER should be addressed timely by the bidder.
31.	Bidder to note that list above is not exhaustive and any work /items required for completing the smooth operation and ensuring satisfactory running of the machines till final hand over to the end user shall also be in the scope of the bidder.
32.	Bidder shall submit the signed and stamped copy of all the pages which constitutes this technical enquiry specification signed by authorized signatory and clearly mentioning each clause under following two categories to avoid any ambiguity in scope understanding & the scope division along with technical offer. a. "Accepted without deviation and considered in scope of work" b. "Not considered in scope of work"
7.0	PACKING AND FORWARDING
1.	Proper packing to be ensured. Indigenous Supply: Agitator & sub system assembly shall be wrapped in polythene bags & packed in a strong rigid wooden crate. Rain water should not enter into the Agitator internals during storage in the outer yard of power plant. Imported Supply: All imported supply should be packed as per Sea worthy packing standards PE-TS-888-100-A001. All imported items should have Sea worthy packing. Liberal packing materials and struts shall be provided to arrest rolling and to protect from transit damages.
2.	Equipment and process materials shall be packed and semi-knocked down, to the extent possible, to facilitate handling and storage and to protect bearings and other machine surfaces from oxidation. Each container, box, crate or bundle shall be reinforced with steel strapping in such a manner that breaking of one strap will not cause complete failure of packaging. The packing shall be of best standard to withstand rough handling and to provide suitable protection from tropical weather while in transit and while awaiting erection at the site.
3.	Equipment and materials in wooden cases or crates shall be properly cushioned to withstand the abuse of handling, transportation and storage. Packing shall include preservatives suitable to tropical conditions. All machine surfaces and bearings shall be coated with oxidation preventive compounds. All parts subject to damage when in contact with water shall be coated with suitable grease and wrapped in heavy asphalt or tar impregnated paper.
4.	Crates and packing material used for shipping will become the property of owner.(END CUSTOMER)
5.	Packaging or shipping units shall be designed within the limitations of the unloading facilities of the receiving ports and the ship will be used. It shall be the bidder's responsibility to investigate these



TECHNICAL SPECIFICATION OF FGD ABSORBER AGITATORS

TRY/PE-BM/FGD/AGITATOR SPEC:001/ Rev 01

S.No	Description
	limitations and to provide suitable packaging and shipping to permit transportation to site.
6.	Packing (tare) shall be part of the equipment cost and shall not be subject to return. The packing should ensure integrity and cohesiveness of each delivery batch of equipment during transportation. In case of equipment assemblies and unit's delivery in the packing of glass, plastics or paper the specification of packing with the material and weight characteristics are to be indicated.
7.	Each package should have the following inscriptions and signs stenciled with an indelible ink legibly and clearly: <ul style="list-style-type: none">a. Destinationb. Package Numberc. Gross and Net Weightd. Dimensionse. Lifting placesf. Handling marks and the following delivery marking
8.	Each package or shipping units shall be clearly marked or stenciled on at least two sides as per the dispatch instruction gives during the contract: In addition, each package or shipping unit shall have the symbol painted in red on at least two sides of the package, covering one fourth of the area of the side.
9.	Each part of the equipment which is to be shipped as a separate piece or smaller parts packed within the same case shall be legibly marked to show the unit of which it is part, and match marked to show its relative position in the unit, to facilitate assembly in the field. Unit marks and match marks shall be made with steel stamps and with paint.
10.	Each case shall contain a packing list showing the detailed contents of the package. When any technical documents are supplied together with the shipment of materials no single package shall contain more than one set of such documents. Shipping papers shall clearly indicate in which packages the technical documents are contained.
11.	The case number shall be written in the form of a fraction, the numerator of which is the serial number of the case and the denominator the total number of case in which a complete unit of equipment is packed.
12.	Wherever necessary besides usual inscriptions the cases shall bear special indication such as "Top", "Do not turn over", "Care" , "Keep Dry" etc. as well as indication of the center of gravity (with red vertical lines) and places for attaching slings (with chain marks)
13.	Marking for Safe handling: To ensure safe handling, packing case shall be marked to show the following: <ul style="list-style-type: none">a. Upright positionb. Sling position and center of Gravity positionc. Storage categoryd. Fragile components (to be marked properly with a clear warning for safe handling)



TECHNICAL SPECIFICATION OF FGD ABSORBER AGITATORS

TRY/PE-BM/FGD/AGITATOR SPEC:001/ Rev 01

S.No	Description
14.	Each crate or package is to contain a packing list in a waterproof envelope. All items are to be clearly marked for easy identification against the packing List. All cases, packages etc. are to be clearly marked on the outside to indicate the total weight where the weight is bearing and the correct position of the slings are to bear an identification mark relating them to the appropriate shipping documents. All stencil marks on the outside of cases are either to be made in waterproof material or protected by shellac or varnish to prevent obliteration in transit.
15.	The packing slip shall contain the following information: - Customer name, Name of the equipment, Purchase Order number with Date, Address of the delivery site, Name and Address of the Sender, Serial Number of Agitator, BHEL item Code, Gross Weight and Net weight of Supplied items.
16.	Prior to transport from manufacturer's work to destination, components of the unit shall be completely cleaned to remove any foreign particles. Flange faces and other machined surfaces shall be protected by an easily removable rust preventive coating followed by suitable wrapping.
17.	All necessary painting, corrosion protection & preservation measures shall be taken as specified in painting schedule. Supplier shall consider the coastal environment zone which is defined as "very severe" during final finishing/shipping.
18.	Successful bidder shall furnish the detail packing /shipment box details with information like packing box size, type of packing, weight of each consignment, sequence no. of dispatch, no. of consignment for each deliverable item against each billing break up units/ billable blocks. Without these details the BBU shall not be approved during detail engineering. Also, complete billing break-up with above mentioned details shall be submitted within 10days of LOI.
19.	All items/equipment shall be dispatched in properly packed condition (i.e. no item shall be dispatched in loose condition such that it becomes difficult to store/identify its location at site at a later stage).
20.	Cases which cannot be marked as above shall have metal tags with the necessary markings on them. The metal tags shall be securely attached to the packages with strong steel binding wire. Each piece, Skid, Case or package shipped separately shall be labelled or tagged properly.



TECHNICAL SPECIFICATION OF FGD ABSORBER AGITATORS

TRY/PE-BM/FGD/AGITATOR SPEC:001/ Rev 01

S.No	Description
8.0	SUPERVISION OF ERECTION, TESTING AND COMMISSIONING
1.	The erection of Agitators will be done by owner as per Erection Manual and check List. However, the bidder shall make visit as per enquiry/PO for the supervision of erection, pre-commissioning & post-commissioning check-up, start-up, testing and trial runs of all the items covered under the scope of supply.
2.	<p>Optional price to be quoted by the bidder in terms of price per man-day for erection and commissioning support.</p> <p>If commissioning engineer is deputed from Indian office, then the payment will be released in INR only.</p> <p>This service will be utilized by BHEL-site through power sector regions. Separate PO will be released by BHEL-Site through power sector regions to avail the vendor's supervision service.</p> <p>Depending upon the actual duration of erection and commissioning support availed, the payment will be paid by BHEL- power sector regions based on the vendor quoted amount (price per man-day).</p> <p>The price calculated for 07 days of erection and commissioning per absorber will be considered for price comparison.</p>
3.	The bidder will be informed well in advance for the visit.
4.	All TA/DA, Site Expenses, Travel charges boarding and lodging shall be borne by the bidder and shall be inclusive in supervision portion.
5.	Price comparison for evaluating the lowest bid will be considered all Main Supply, Supervision of E&C charges and Mandatory Spares price all together.
9.0	EXCLUSION
	<p>The following work associated with the Agitators will be by others:</p> <ul style="list-style-type: none">a. Walkways, platforms and laddersb. Element handling hoists.



TECHNICAL SPECIFICATION OF FGD ABSORBER AGITATORS

TRY/PE-BM/FGD/AGITATOR SPEC:001/ Rev 01

S.No	Description
10.0	INSPECTION, TESTING AND QUALITY REQUIREMENTS
	<p>A detail quality plan is to be submitted along with offer for all items marked "Full Compliance Material". Refer "Annexure – VIII" for Indicative Quality Plan & "Annexure – IX" Customer Quality Requirements for LT motors.</p> <p>NOTE: <i>Indicative Quality Plan</i> is for reference purpose only and is not exhaustive. All relevant points of Technical Specification shall be addressed in the Final MQP. The MQP approval will be given only post-contract stage and is subject to the addition of inspection stages or quantum by the customer and shall be performed by the Supplier without any cost/delivery implication.</p> <p>The General inspection requirements to be considered are as below:</p>
1.	Bidder shall furnish written copies of shop production, fabrication and quality test procedures and drawings to be used on the Agitators for review by BHEL/END CUSTOMER prior to manufacture.
2.	The Bidder shall furnish performance test procedure along with standard. The test procedure will be reviewed and approved by the BHEL/END CUSTOMER.
3.	Since there is no standard for "Acceptance Test Procedure" for Agitator, Agitator manufacturer is to submit a test procedure and Quality Plan, clearly indicating that equipment will meet the desired parameter.
4.	Power consumption at motor terminal and vibration of equipment will be conducted at site. Vendor to indicate other material tests that are to be conducted as per their practice in their Quality plan.
5.	Clause Deleted.
6.	DYNAMICS
7.1	CRITICAL SPEED
7.1.1	Operation speed of the Agitator motor shall be at least 25% below the first critical speed
7.1.2	Additional to the requirement of the critical speed of Agitator, as specified above. Agitator manufacturer is to analyze the torsional critical speed of combined system of Agitator, Gear Box and Motor to establish that the torsional critical speed is well off the operating speed by 20% from the operating speed.
7.2	VIBRATION SEVERITY
7.2.1	During performance test, unfiltered vibration measurements shall be made with running of Agitator in Air. Measurement shall be taken on the Gear Box thrust bearing housings as well in motor top.
7.2.2	Guaranteed Site vibration of the equipment on its own pedestal, at commissioning with normal level of liquid and with maximum liquid at respective tank, Vibration limit at site will be as per ISO-10816.
7.2.3	Vibration measurements of bearing housing shall be made in root mean square (RMS) velocity.
7.2.4	Vibration levels measured on the non-rotating parts shall not exceed the zone limit "B" as defined in ISO 10816 at steady conditions and shall not exceed the zone limit "C" as defined in ISO 10816 at



TECHNICAL SPECIFICATION OF FGD ABSORBER AGITATORS

TRY/PE-BM/FGD/AGITATOR SPEC:001/ Rev 01

S.No	Description
	transient conditions.
8.	For surfaces with rubber lining Welding shall be visually inspected to verify the absence of rough area and unacceptable transition between surfaces which prevent the adequate adherence of rubber. The acceptance criteria shall be as per latest standard.
9.	For surfaces with rubber lining, degree of cleaning shall be visually checked before the application of the coating. There must be no area with oxidation, dirt or partially or generalized corrosion defects.
10.	Test certificates shall be issued for each lot of raw material used in the coating, corresponding to specific weight and traction resistance.
11.	For surfaces with rubber lining, adherence test shall be conducted on production samples. Adherence test shall be conducted on the actual surface through hammering. In order to verify the absence of air packets (or) surface without adherence.
12.	For surfaces with rubber lining, Coating thickness shall be checked at 100%. A High voltage porosity test will be conducted on 100 % of the coated surface.
13.	Out of all Agitators One Number of each type will be inspected at the Bidder's works before dispatch or where the test facilities are available.
14.	The Bidder shall conduct performance test for the remaining Agitators and submit the reports.
15.	Contract shaft mechanical seals shall be used during shop tests, unless the seal design is unsuitable for the shop-test condition, if applicable.
16.	Agitators shall not be released for shipment, until shop tests data and performance tests curves have been approved by Owner.
17.	Bidder should furnish performance guarantee as per applicable standard guarantee for the design, manufacture, material and safe operation of the equipment's.
18.	BHEL shall witness the test at Bidder's works and a notice of minimum three (3) weeks shall be given for attending the inspection.
19.	Bidder to arrange all calibrated gauges, Instruments during inspection.
20.	Mechanical running and the performance test shall be carried out. Bidder to arrange Motor of same / higher rating for the shop test and inspection.
21.	Final acceptance of the quality plan will be approved by ultimate user (hereafter called END CUSTOMER) during post order stage. Hence, it is expected that manufacturer to submit quality plan (QAP) along with the offer. The same shall be followed at post order stage also. QAP should be as per the best practice followed internationally to avoid any conflict of interest.
22.	Raw material of fastener must undergo Inter-granular Corrosion test as per ISO-3651, Part-1 for Nitric Acid test.



TECHNICAL SPECIFICATION OF FGD ABSORBER AGITATORS

TRY/PE-BM/FGD/AGITATOR SPEC:001/ Rev 01

S.No	Description
11.0	PAINTING
1.	<p>Painting details for agitator support: -</p> <p>Surface Preparation: Blast Cleaning SA 2.5</p> <p>PRIMER COAT:</p> <p>a. Primer: One coat of Two component moisture curing zinc (ethyl) silicate primer coat (Min 80% metallic zinc content in dry film, solid by volume minimum 60% ±2). Zinc dust composition and properties shall be as per Type II as per ASTM D520-00 DFT- 70µ</p> <p>Intermediate: One coat of Two component polyamide cured epoxy with MIO content (containing lamellar MIO Min 30% on pigment, solid by volume min. 80%±2) DFT- 100µ .</p> <p>FINISH COAT:</p> <p>Two coats of two pack aliphatic isocyanate cured acrylic polyurethane paint to IS 13213 solid by volume min.55%±2) DFT- 35µ/ coat With gloss retention (SSPC paint spec no.36, ASTM D4587, D2244, D523 of level 2 after min. 1000 hrs exposure, gloss less than 30 and colour change less than 2.0Δ E)</p> <p>COLOUR CODE</p> <p>Base: To be informed during contract stage</p> <p>Lettering: To be informed during contract stage</p>
2.	Rust preventive paint after inspection at shop floor before dispatch shall be in bidder's scope
3.	Corrosion protection, coating and galvanizing, painting shall be taken care by the bidder. Bidder shall submit the painting scheme during detail Engg in line with the specification and shall be subject to approval of BHEL / END CUSTOMER.
12.0	SPARES, TOOLS & TACKLES
	Any special tools & tackles required for the entire equipment to disassemble, assemble or maintain the units, they shall be included in the quotation and furnished as part of the initial supply of the machine. List of special tools & tackles shall be decided by bidder as per his proven practice. When special tools are provided, they shall be packaged in separate, boxes with lugs and marked as "Special Tools for (tag / item number)." Each tool shall be stamped or tagged to indicate its intended usage. Levers and eye bolts for the removal of parts to be serviced shall be submitted with special tools.
12.1	START UP & COMMISSIONING SPARES
	Start-up & Commissioning Spares shall be part of the main supply of the Agitators. Start-up & commissioning spares are those spares which may be required during the start- up and commissioning of the equipment/system. All spares required for successful operation till commissioning of Agitator shall come under this category. Bidder shall provide an adequate stock of such start up and commissioning spares, the same shall be supplied along with main supply to the site for the equipment erection and commissioning. The spares must be available at site before the equipment's are energized. The List of such spares to be provided during bidding stage.



TECHNICAL SPECIFICATION OF FGD ABSORBER AGITATORS

TRY/PE-BM/FGD/AGITATOR SPEC:001/ Rev 01

S.No	Description
12.2	RECOMMENDED SPARES
	Bidders shall also furnish the recommended spares list along with the offer required for 3 years of normal operation of the plant and should be independent of the list of the mandatory spares. Prices of recommended spares will not be used for evaluation of the bids. The price of these spares will remain valid up to 6 months after placement of Notification of Award for the main equipment
12.3	MANDATORY SPARES:
	<p>Bidder to quote for the mandatory spares as per the Mandatory Spare list given for a specific project (Refer "Annexure-XI").</p> <p>Bidder shall quote for the "Mandatory Spares Part List", and it will be considered for L1 evaluation. mandatory spare parts items shall be handed over separately and shall not be mixed with the supply of the main equipment parts. Spares shall be sent in pre-decided lots in containers/secure boxes. All boxes/containers are to be distinctly marked in red color with boldly written "S" mark on each face of the containers. Spares shall not be dispatched before dispatch of corresponding main equipment's. Each item shall be labelled in English and be packed against damage and sealed to prevent deterioration from corrosion. The protection shall be sufficient for a minimum of 10 years' storage in a dry weatherproof building.</p> <p>All spares supplied under this contract shall be strictly inter-changeable with the parts for which they are intended for replacements. All the mandatory spares shall be manufactures along with the main equipment components as a continuous operation as per same specification and quality plan.</p> <p>Any special tools & tackles required for the entire equipment to disassemble, assemble or maintain the units, they shall be included in the quotation and furnished as part of the initial supply of the machine. List of special tools & tackles shall be decided by bidder as per his proven practice. When special tools are provided, they shall be packaged in separate, boxes with lugs and marked as "Special Tools for (tag / item number)." Each tool shall be stamped or tagged to indicate its intended usage. Levers and eye bolts for the removal of parts to be serviced shall be submitted with special tools.</p>
13.0	PERFORMANCE GUARANTEE
	<p>All performance tests for Agitators shall be carried out by bidder in accordance with any latest international codes/standards.</p> <p>Bidder shall furnish Performance guarantee for the design, manufacture, material, safe and trouble-free operation of the Agitators and its accessories</p> <p>The Bidder shall ensure a design of the equipment to achieve an average target availability of 98% for 120 days and average target availability of 95% for 1 year.</p> <p>Noise level ≤ 85 dB (A) at 1m horizontal distance from equipment/enclosures and 1.5m above operating floor is to be guaranteed.</p> <p>Vibration levels measured on the non-rotating parts shall not exceed the zone limit "B" as defined in ISO 10816 at steady conditions and shall not exceed the zone limit "C" as defined in ISO 10816 at transient conditions.</p>



TECHNICAL SPECIFICATION OF FGD ABSORBER AGITATORS

TRY/PE-BM/FGD/AGITATOR SPEC:001/ Rev 01

S.No	Description
	Acceptance tests to be carried out as per the procedure defined by the bidder which shall be submitted for BHEL/ END CUSTOMER approval. In the event that the performance test is unsuccessful, bidder shall take necessary remedial action at his cost and the performance test shall be repeated.
14.0	WARRANTY/DEFECT LIABILITY
1.	The Bidder warrants that the equipment's/items shall be free from defects in the design, engineering, materials and workmanship of the Plant and Equipment supplied and of the work executed. The Warranty Period shall be twenty-four (24) months from the date of Supply or eighteen (18) months from the date of commissioning, whichever first occurs. If during the Warranty/Defect Liability Period any defect should be found in the design, engineering, materials and workmanship of the Plant and Equipment supplied or of the work executed by the Bidder, the Bidder shall promptly, in consultation and agreement with BHEL regarding appropriate remedying of the defects, and at its cost, repair, replace or otherwise make good (as the Bidder shall, at its discretion, determine) such defect as well as any damage to the Facilities caused by such defect.
2.	In case of failure of the equipment to meet the guarantee, END CUSTOMER/BHEL reserves the right to reject the equipment. However, END CUSTOMER/BHEL reserves the right to use the equipment until new equipment supplied by bidder meets the guaranteed requirement .
15.0	FIRST FILL OF CONSUMABLES:
	Bidder's scope shall also include supply and filling of all chemicals, reagents, resins, lubricants, grease, filters and consumable items for operation up to commissioning including top up requirements. All lubricants proposed for the plant operation shall be suitable for all operating and environmental conditions that will be met on site consistent with good maintenance procedures as instructed in the maintenance manuals.
	Detailed specifications for the lubricating oil, grease, gases, servo fluids, control fluids, chemicals including items qualities and quantities required per month of the plant operation for the END CUSTOMER/BHEL's approval herein shall be furnished within 2 months of placement of Order. On completion of erection complete list of bearings/equipment giving their location and identification marks shall be furnished to BHEL along with lubrication requirements. All types of consumables, lubricants and grease shall be readily obtainable locally and the number of different types shall be kept to a minimum. For each type and grade of lubricant recommended, bidder shall list at least three equivalent lubricants manufactured by alternative companies.
16.0	TRAINING
	Successful bidder shall provide comprehensive training for END CUSTOMER/BHEL Engineering, O&M, Erection & Commissioning staffs at site covering all aspects of the Agitators - Operation & Maintenance, Troubleshooting etc.



TECHNICAL SPECIFICATION OF FGD ABSORBER AGITATORS

TRY/PE-BM/FGD/AGITATOR SPEC:001/ Rev 01

S.No	Description
17.0	CONFLICT
	Bidder's equipment shall be designed for and shall meet the service, performance and minimum level of quality requirements specified. Bidder shall be solely responsible for advising END CUSTOMER in writing of any conflicts between the specifications and Bidder's design, including performance and levels of quality. Bidder agrees that its obligations, liabilities and warranties shall not be diminished or extinguished due to its meeting the requirements of the Specification.
18.0	DOCUMENTATION
A	DOCUMENTS TO BE SUBMITTED ALONG WITH THE OFFER
	The Bidder shall submit all documents, drawings, diagrams and all such information, which are necessary to fully understand the offer for techno – commercial Offer. Vendors are requested to comply with above in all respect.
B	DOCUMENTS TO BE SUBMITTED AFTER AWARD OF CONTRACT
	<p>The Successful bidder shall submit necessary data, documents and drawings for review, approval as specified in this specification. Drawings that are reviewed by the END CUSTOMER/ BHEL will be returned to bidder with a transmittal letter with any comments and / or questions marked on the drawings or noted in the letter. All comments and questions must be resolved before a resubmission of drawings / documents. If the design has not developed enough to resolve some of the comments or questions, bidder shall place a "hold" on those items or areas of design. END CUSTOMER/ BHEL reserves the right to return drawings unprocessed to bidder if there exists any evidence that bidder has not acknowledged all comments and questions.</p> <p>All necessary GA drawings, sections, sub-assembly drawings, specifications of main and sub components and necessary set of operation & maintenance manual as asked by END CUSTOMER must be furnished by bidder in soft and hard copy forms. For all documents softcopy format shall be searchable pdf, however in addition all drawings, diagrams shall be supplied in ACAD or other editable format and all lists in Excel format. Further break up of technical documents will be discussed during finalization of the purchase contract.</p> <p>Unless agreed otherwise, Ten (10) hard copies and five (05) sets of electronic copies of all documents are to be submitted in the English language. Electronic Copies shall be submitted in primary original data format (e.g. DOC, XLS, DWG) as well as in a printable non-proprietary document format (e.g. PDF). Especially P&IDs shall be submitted as DWG files and PDF files. Bidder to ensure submission of hard copies as per END CUSTOMER requirement for all engineering drg/doc and for all subsequent revisions along with a soft copy through email to concerned project team.</p>



TECHNICAL SPECIFICATION OF FGD ABSORBER AGITATORS

TRY/PE-BM/FGD/AGITATOR SPEC:001/ Rev 01

ANNEXURE-I – REFERENCE LIST

Project :

Enquiry No :

REFERENCE LIST as per format shown below. (Reference plant details for Horizontal Agitators)

S.No	Project Name , Customer & Plant capacity	Coal fired Yes/No	Wet Limest one Based FGD Yes/No	Model	Size of Tank	Type Horizontal / Vertical	Speed rpm	Year of Commg	Qty

Note :

Bidders shall also submit reference list of Horizontal agitators as per the format given above.

BIDDER SIGN : _____

DESIGNATION : _____

DATE : _____

BIDDER SIGN WITH SEAL AND DATE:



TECHNICAL SPECIFICATION OF FGD ABSORBER AGITATORS

TRY/PE-BM/FGD/AGITATOR SPEC:001/ Rev 01

Annexure-II TECHNICAL DATASHEET OF AGITATORS (TO BE FILLED FOR EACH AGITATOR)

Project :

Enquiry No:

SL.NO	PARAMETERS	UNITS	DATA
1.	General		
1.1	Project		
1.2	Ultimate Customer		
1.3	Location		
1.4	Order Number/Enquiry No		
1.5	Agitator Name		
1.6	Service		
1.7	Installation		
1.8	No. of Agitator per Tank		
1.9	Total No's of Agitator for all the units		
1.10	Type of Agitator		SIDE ENTRY
1.11	Model Number		
1.12	No of Stage(No of propeller per Agitator)		
1.13	Mounting of Agitator		
1.14	Mounting of Gear Head		
1.15	Mounting of Motor		
2	Performance Details		
a.	Input power at Motor terminal at highest frequency and Maximum liquid level in tank	KW	
b.	Input power at Motor terminal at Normal frequency (50Hz) and Normal liquid level in tank	KW	
c.	Motor rating	KW	
d.	Rated speed	rpm	
e.	Critical Speed	rpm	
f.	Tip speed	m/s	
g.	Direction of rotation of Motor and Gear box viewed from Motor non-driving end		
h.	Direction of rotation of Agitator viewed from Gear head end		
i.	Minimum submergence required over blade centre line for continuous operation	mm	
j.	Impeller diameter	mm	
k.	Minimum clearance required below impeller centre line	mm	
l.	Maximum liquid level over propeller centre line up to which Agitator can work without overloading of motor at 50Hz	mm	



TECHNICAL SPECIFICATION OF FGD ABSORBER AGITATORS

TRY/PE-BM/FGD/AGITATOR SPEC:001/ Rev 01

3	Construction Features		
3.1	Impeller		
	a) Type		
	b) Diameter(tip to tip)	mm	
	c) Hub diameter	mm	
	d) No of blade per Impeller		
	e) Thickness of blade	mm	
3.2	Tube thickness, if any	mm	
3.3	Shaft diameter at coupling (GH-Agitator)	mm	
3.4	Length of Top shaft	mm	
3.5	Connection Details		
	· Blade to Hub:		
	· Hub to Shaft/Tube		
	· Line Shaft to Line shaft		
	· Line shaft to top shaft		
3.6	Bearings in Gear Head		
	Thrust bearings Housing		
	a) Type		
	b) Make		
	Bearing Number		
	· Radial Bearing		
	· Radial Bearing		
	· Thrust Bearing		
	c) Type of lubrication		
	d) Lubricator		
3.7	Coupling between Agitator & Gear Head		
	a) Type		
	b) Make & Model No.		
	c) Rating	KW/rpm	
3.8	Stuffing Box/Mechanical Seal		
	a) Type		
	b) Details of gland packing		
	c) No of packing		
	d) Cooling water		
	e) Lubrication type		
	f) Qty of grease and interval of lubrication.		
4	Material of Construction		
a.	Blade of Impeller		
b.	Hub of Impeller		
c.	Base Plate/Gear head Stand		
d.	Line Shaft & Line shaft Coupling		
e.	Impeller Shaft		
f.	Top Shaft		
g.	Gland Sleeve		
h.	Location of Thrust bearing		
i.	Coupling guard		



TECHNICAL SPECIFICATION OF FGD ABSORBER AGITATORS

TRY/PE-BM/FGD/AGITATOR SPEC:001/ Rev 01

j.	Fasteners in Wet region		
k.	Fasteners in Dry region		
l.	Stuffing Box		
m.	Gland		
n.	Gland packing		
5	Weight		
	a) Bare Agitator weight Kgs		
	b)Rotating Assembly weight Kgs		
	c) Motor weight Kgs		
	d) Gear Head weight Kgs		
	e)Wt. of the equipment, (a+c+d)		
	f) Heaviest single piece component of Agitator to be handled. Kgs		



TECHNICAL SPECIFICATION OF FGD ABSORBER AGITATORS

TRY/PE-BM/FGD/AGITATOR SPEC:001/ Rev 01

Annexure-III MOTOR SIZING CALCULATION (TO BE FILLED FOR EACH AGITATOR)

Project :

Enquiry No :

S.No	Parameters		Data
1	Tank size (Dimension in m)		
2	Specific Gravity of Slurry	ρ	
3	IMPELLER TIP DIA(in m)	d	
4	AGITATOR SPEED(RPM)	n	
5	POWER NO OF THE AGITATOR	N_p	
6	NO OF IMPELLER STAGES	l	
7	AGITATOR POWER(P)	$N_p * \rho * d^5 * n^3 * l$	
8	GEARBOX EFFICIENCY	η_1	
9	BEARING TRANSMISSION EFFICIENCY	η_2	
10	EFFICIENCY DUE TO ANY OTHER LOSSES	η_3	
11	MECHANICAL POWER REQUIRED	$\text{Agitator BKW} = P / (\eta_1 * \eta_2 * \eta_3)$	
12	MOTOR EFFICIENCY	η	
13	Rated Input Power at Motor Terminal at Normal water level and at Normal voltage and Frequency or Agitator BKW	$\text{Power consumed at Motor terminal} = \text{Agitator BKW} / \eta$	
14	MOTOR POWER (KW)	Motor Power shall be at least 1.2 times the Power consumed at Motor Terminal.	



TECHNICAL SPECIFICATION OF FGD ABSORBER AGITATORS

TRY/PE-BM/FGD/AGITATOR SPEC:001/ Rev 01

Annexure-IV MOTOR DATASHEET FOR AGITATORS (TO BE FILLED FOR EACH AGITATOR)

Project :

Enquiry No :

SL.NO	DESCRIPTION	DATA
A.	GENERAL	
1.	Manufacturer & Country of origin.	
2.	Equipment driven by motor	"Name of the Agitator"
3.	Motor type	
4.	Quantity	
B.	DESIGN AND PERFORMANCE DATA	
1.	Frame size	
2.	Type of duty	
3.	Type of enclosure /Method of cooling/ Degree of protection	
4.	Applicable standard to which motor generally conforms	
5.	Efficiency class as per IS 12615(IE3)	
6.	(a)Whether motor is flame proof	
	(b)If yes, the gas group to which it conforms as per IS:2148	
7.	Type of mounting	
8.	Direction of rotation as viewed from DE END	
9.	Standard continuous rating at 40 deg.C. Ambient temp. as per Indian Standard (KW)	
10.	Derated rating for specified normal condition i.e. 50 deg. C ambient temperature (KW)	
11.	Maximum continuous load demand of driven equipment in KW	
12.	Rated Voltage (volts)	
13.	Permissible variation of :	
	a. Voltage (Volts)	
	b. Frequency (Hz)	
	c. Combined voltage and frequency	
14.	Rated speed at rated voltage and frequency(RPM)	
15.	At rated Voltage and frequency:	
	a. Full load current	
	b. No load current	
16.	Power Factor at	



TECHNICAL SPECIFICATION OF FGD ABSORBER AGITATORS

TRY/PE-BM/FGD/AGITATOR SPEC:001/ Rev 01

	a. 100%/75%/50% load	
	b. NO load	
	c. Starting.	
17.	Efficiency at rated voltage and Frequency,	
	a.100% load	
	b. 75% load	
	c. 50% load	
18.	Starting current (amps) at	
	a. 100 % voltage	
	b. 85% voltage	
	c. 80% voltage	
19.	Minimum permissible starting Voltage (Volts)	
20.	Starting time with minimum permissible voltage/80%/ 100%/ 110%	
	a. Without driven equipment coupled	
	b. With driven equipment coupled	
21.	Safe stall time with 100% ,110% & 80% of rated voltage	
	a. From hot condition	
	b. From cold condition	
22.	Torques :	
	a. Starting torque at min. permissible voltage(kg-mtr.)/ rated voltage	
	b. Pull up torque at rated voltage.	
	c. Pull out torque	
	d. Min accelerating torque (kg.m) available at lowest permissible starting voltage	
	e. Rated torque (kg.m)	
23.	Stator winding resistance per phase (ohms at 20 Deg.C.)	
24.	GD2 value of motors	
25.	No of permissible successive starts when motor is in hot condition	
26.	Locked Rotor KVA Input	
27.	Locked Rotor KVA/KW	
28.	Vibration limit :Velocity (mm/s)	
29.	Noise level limit (dBA)	
C.	CONSTRUCTIONAL FEATURES	
1.	Stator winding insulation	
	a. Class & Type	



TECHNICAL SPECIFICATION OF FGD ABSORBER AGITATORS

TRY/PE-BM/FGD/AGITATOR SPEC:001/ Rev 01

	b. Winding Insulation Process	
	c. Tropicalised (Yes/No)	
	d. Temperature rise over specified maximum ambient temperature of 50 deg C	
	e. Method of temperature measurement	
	f. Stator winding connection	
2.	Main Terminal Box	
	a. Type	
	b. Location(viewed from NDE side)	
	c. Entry of cables(bottom/side)	
	d. Recommended cable size(To be matched with cable size envisaged by owner)	
	e. Fault level (MVA),Fault level duration(sec)	
	f. Cable glands & lugs details (shall be suitable for power cable)	
3.	Type of DE/NDE Bearing	
4.	Motor Paint shade	
5.	Weight of	
	a. Motor stator (KG)	
	b. Motor Rotor (KG)	
	c. Total weight (KG)	
D.	List of accessories.	
1.	Space Heaters (Nos./Power in watts/supply voltage)	
2.	Terminal Box for Space Heater (Yes/No)	
3.	Speed switch (Yes/No)	
	No of contacts and contact ratings of speed switch	
4.	Insulation of bearing (Yes/No)	
5.	Noise reducer(Yes/No)	
6.	Grounding pads	
	i) No and size on motor body	
	ii) Nos on terminal Box	
7.	Any other fitments	
E.	List of curves.	
	Torque speed characteristic of the motor	



TECHNICAL SPECIFICATION OF FGD ABSORBER AGITATORS

TRY/PE-BM/FGD/AGITATOR SPEC:001/ Rev 01

	Thermal withstand characteristic	
	Starting. current Vs. Time	
	Starting. current Vs speed	
	P.F. and Effi. Vs Load	



TECHNICAL SPECIFICATION OF FGD ABSORBER AGITATORS

TRY/PE-BM/FGD/AGITATOR SPEC:001/ Rev 01

Annexure-V -Schedule of Guarantees (TO BE FILLED FOR EACH AGITATOR)

Project:

Enquiry No:

Agitator Name:

SL. NO.	DESCRIPTION	UNIT	DATA
1	Rated Input Power at Motor Terminal at Normal water level and at Normal voltage and Frequency (*)	KW	
2	Possible Rate of deposit of solid particles at tank bottom of total solid particle inflow/outflow	%	
2	Noise level at a distance of 1.0 meter from the equipment at site	dB(A)	85
3	Maximum vibration velocity at site (RMS)	mm/sec	
4	Life of Agitator components parts from the date of Commissioning for continuous operation		24 months
5	Anti-friction Bearing		25000 hrs.

BIDDER SIGN : _____

DESIGNATION : _____

DATE : _____



TECHNICAL SPECIFICATION OF FGD ABSORBER AGITATORS

TRY/PE-BM/FGD/AGITATOR SPEC:001/ Rev 01

Annexure-VI-- LIST OF DEVIATIONS OR EXCEPTIONS TO THE ENQUIRY DOCUMENT

Project :

Enquiry No:

*We hereby accept to the Technical Specification for agitators and **all the parameters for this project**

SIGNATURE OF BIDDER -----

NAME -----

DESIGNATION -----

(OR)

*The following are the technical deviations to the specification:

SI No	Clause No	Page No	Description of Deviation

SIGNATURE OF BIDDER -----

NAME -----

DESIGNATION -----

*Strike out whichever is not applicable

BIDDER SIGN WITH SEAL AND DATE:

SIDE VIEW

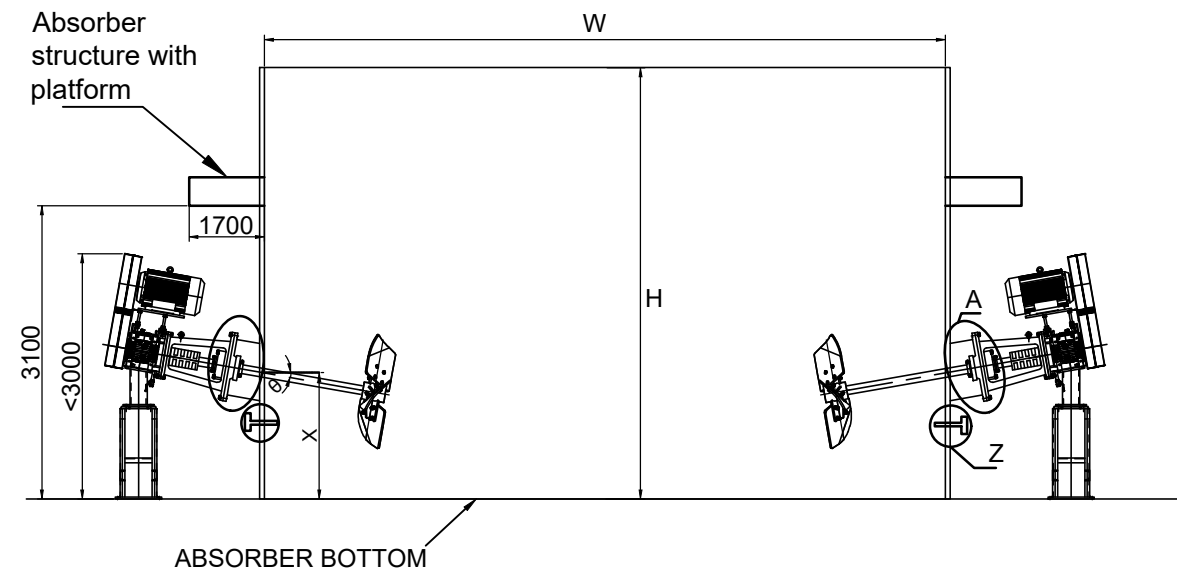

TOP VIEW

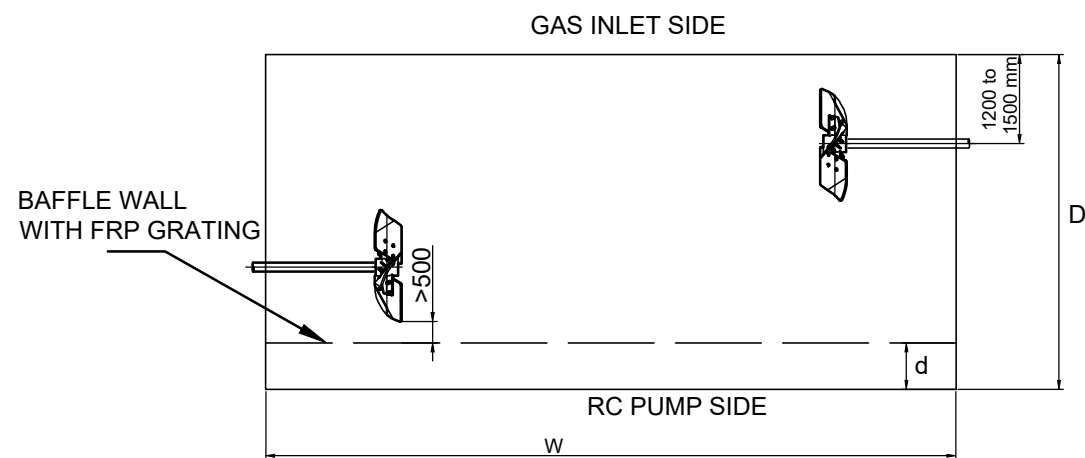

NOTES:-

1. TYPICAL ARRANGEMENT IS SHOWN WITH V BELT & PULLEY. VENDOR CAN ALSO OFFER GEAR BOX DRIVEN AGITATOR.
2. FOR TANK HEIGHT (H), WIDTH(W) AND DEPTH(D), BIDDER SHALL REFER TO BE TECHNICAL INFORMATION FOR SIZING OF ABSORBER AGITATORS
3. BAFFLE WALL IS LOCATED AT A DISTANCE 'd' FROM THE ABSORBER WALL
IF $D < \text{or} = 9900 \text{ MM}$, THEN $d = 2200 \text{ MM}$
 $D > 9900 \text{ MM}$, THEN $d = (D - 8000) \text{ MM}$
THE ABSORBER AGITATOR SHALL BE DESIGNED TO PREVENT THE SLURRY SETTLEMENT AT BOTTOM OF THE ENTIRE TANK INCLUDING THE AREA BETWEEN THE BAFFLE WALL AND THE ABSORBER WALL.
4. THE AGITATOR LOCATION SHALL BE SUGGESTED BY VENDOR CONSIDERING THE LOCATION OF THE BAFFLE WALL. BAFFLE WALL IS MADE OF FRP GRATINGS, VENDOR TO INDICATE THE VALUE OF X AND θ .
5. AGITATOR AND EMERGENCY FLUSH LINE NOZZLES SUPPLY BY BHEL, HOWEVER COMPLETE DESIGN, ENGINEERING, PRODUCTION DRAWINGS AND SUPPORT FOR PRODUCTION ARE IN AGITATOR VENDOR SCOPE

ABSORBER AGITATOR NOZZLE ARRANGEMENT

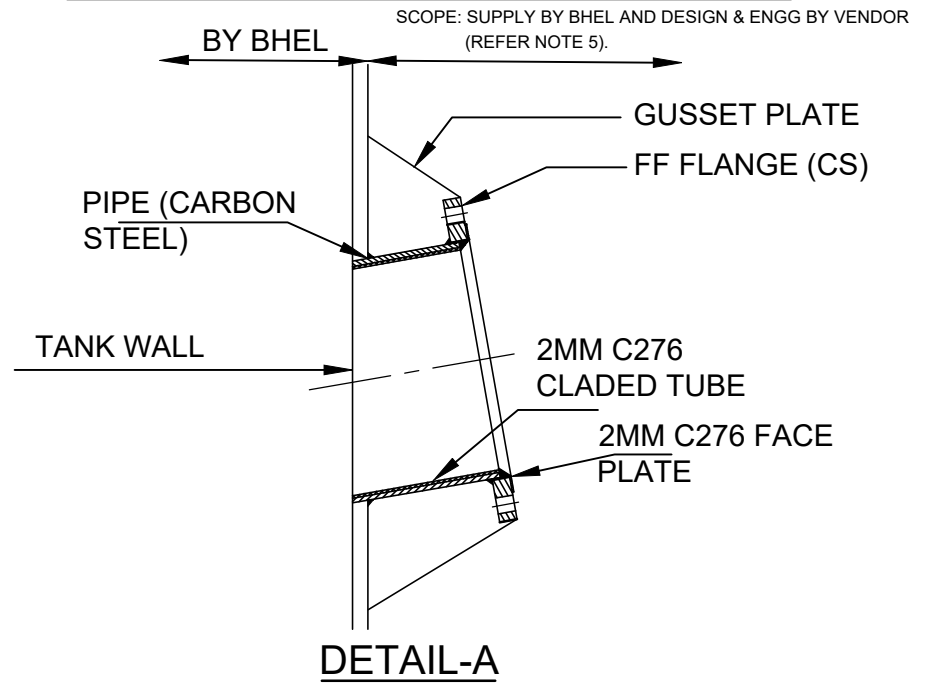

EMERGENCY FLUSH PIPE ARRANGEMENT (ABSORBER AGITATOR)

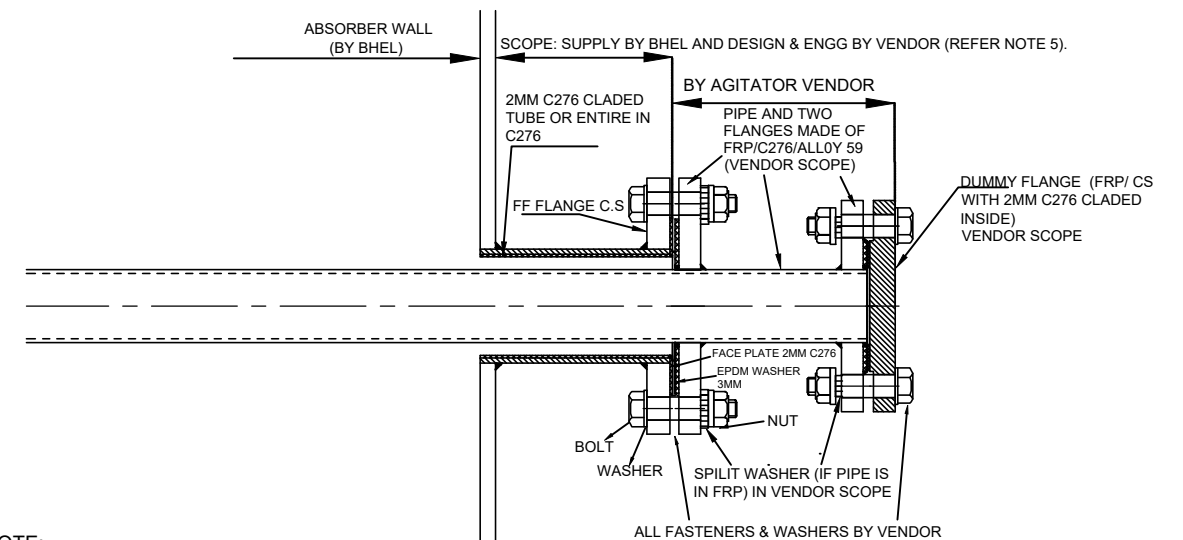

NOTE:

FLAT FACE SHEET ON C276 CLADDING FLANGE SHALL ACT AS RAISED FACE. OD OF C276 SHEET ON THE FLANGE SHALL BE EQUAL TO ASME B16.5 CLASS 150.

DETAIL-Z

CAUTION: The information on this document is the property of BHARAT HEAVY ELECTRICALS LTD. It must not be used directly or indirectly in any way detrimental to the interest of the company.	TYPE OF PRODUCT OR NAME OF CUSTOMER/PROJECT		FGD SYSTEM PACKAGE			
	Bharat Heavy Electricals Ltd UNIT: HIGH PRESSURE BOILER PLANT TIRUCHIRAPALLI - 620014		DRN	NAME	SIGNATURE	DATE
			CHD	THANGAMALAR P		21.03.2021
			APPD	SATHESH KUMAR S		21.03.2021
DEPT	BM	ALL DIMENSIONS ARE IN MM	PROJECTION	SCALE	WEIGHT (Kg)	REF TO ASSY / OLD DWG
CODE	121		NTS			
TITLE					DRAWING NO :	REV
TYPICAL ARRANGEMENT OF SIDE ENTRY AGITATOR IN ABSORBER					3-FG-365-08024	00

TECHNICAL INFORMATION FOR SIZING OF ABSORBER AGITATORS
PROJECT: TANGEDCO 1X800 MW AT NORTH CHENNAI FGD SYSTEM PACKAGE

1	Absorber Details	
1.1	Tank shape	Rectangular
1.2	Dimension of tank (m)	23.9 W X 9.9 D X 5.0H
1.3	Capacity of tank (in m3)	1183.05 m ³
1.4	No. of absorber tank	1 no.
1.5	Total no. of tanks	1 no.
2	Agitator selection data	
2.1	Type	Marine Propeller – Horizontal Type (Side Entry)
2.2	Medium to be handled	Gypsum slurry
2.3	Seal Type	Mechanical seal (emergency flush start) required in case of side entry
2.4	Duty	continuous
2.5	Agitator location	Outdoor
2.6	Operation	Whenever Recirculation Pumps are not running.
2.7	MOC of Agitator	Agitator Shaft (which is continuously in contact with slurry) and blades shall be made with Alloy 926 or better material
2.8	Minimum liquid level in the tank	4.7
2.9	Normal liquid level in the tank	5.0
2.10	Maximum liquid level in the tank	6
2.11	Quantity of Agitators per Tank	2 No's + 1 warehouse spare
2.12	Total Quantity	3 nos x 1 units = 3 nos
3	Slurry Analysis	
3.1	Maximum solid particle size	200 mesh (74 μ)
3.2	Normal solid particle size, d50	325 mesh (44 μ)
3.3	Solid to be handled	gypsum along with Limestone & other impurities
3.4	Chloride concentration	max 30000 ppm
3.5	Hardness of particle	5-7 mohs scale
3.6	Slurry concentration, wt%	30%
3.7	Sp. Gravity of slurry	1.219
3.8	Sp. Gravity of Lime Stone & Gypsum	2.32(avg)
3.9	Viscosity of Slurry	10 cP
3.10	pH	4 to 8
3.11	SiO ₂ Content	4 to 6 g/l
3.12	Temperature	Normal 62 deg C; Design 70 deg C.
3	Power loading for auxiliary power consumption	not applicable
4	Power loading per KW in USD	refer tender spec
5	Mandatory spares	Please refer to marketing mandatory spares list

Project: NORTH CHENNAI 1x800 MW- FGD									
Cont No: G802		Rev 00		Rev 01		Rev 02		Rev 03	
		Sign	Date	Sign	Date	Sign	Date	Sign	Date
Engineer	VV		15.03.22						
Reviewer	PNR		15.02.22						
Approver	ACR		15.03.22						



BHARAT HEAVY ELECTRICALS LIMITED

HIGH PRESSURE BOILER PLANT, TIRUCHIRAPALLI-620 014

CONTROLS & INSTRUMENTATION/FB

Page 1 of 7

TECHNICAL SPECIFICATION OF

LT AC MOTORS (SAFE AREA)

SPECIFICATION REFERENCE – TCI : 140, Rev. 13

Revision History

Rev. No.	Date	Description	Prepared & Reviewed	Approved
01 -12		Earlier Revisions	-Sd-	-Sd-
13	05-03-22	General Revisit	M. M. M. Jombh	D. Karitha 8/3/2022



Sl. No.	Description	Requirement
1	Site Conditions :-	
	Altitude above MSL	500 meters
	Ambient temperature	50° C
	Relative Humidity	100 %
	Atmosphere	Tropical, dusty, salty, corrosive and highly polluted environment.
2	Motor type	Squirrel cage type induction motor suitable for direct on line starting through any type of breaker.
3	Applicable Standards	IS-325, IS 12615, IS/IEC-60034, IS-12065, IS-12075, IS 15999, IS/IEC-60529, IS 4029, IS-1231, IS-6362, IS-2253. (Latest version of relevant standards shall be referred).
4	Type of Enclosure and degree of protection	Totally Enclosed Fan Cooled (TEFC), IP-55 as per IS/IEC-60529
5	Duty Cycle	Continuous, S1
6	Energy Efficiency Class	IE2/IE-3 as per IS-12615/IEC 60034-30. Refer project specific transmittal furnished along with enquiry for applicable energy efficiency class.
7	Rated Voltage & Tolerance	415 V AC, 3 Phase, $\pm 10\%$.
8	Rated Frequency & Tolerance	50 Hz, $\pm 5\%$
9	Combined voltage & frequency tolerance	10 % (absolute sum)
10	General Requirements	<p>a. All motors shall be so designed that maximum inrush currents, locked rotor and pull out torque, developed at the extreme voltage and frequency variations do not endanger the motor and driven equipment.</p> <p>b. Motor shall be designed to keep the torsional and rotational natural frequencies of vibration, at least 25 percent above the motor rated speed ranges to avoid resonant vibration over the operating speed range of the motor and driven equipment.</p>



Sl. No.	Description	Requirement
		c. Maximum continuous rating (MCR) of the motor shall have at least 15 % margin over the maximum load demand of the driven equipment including voltage and frequency variation. (Applicable only if vendor supplies motor along with the driven equipment or load).
11	Torque requirements	Accelerating torque at any speed with the lowest permissible starting voltage shall be at least 10% of motor full load torque. Pull Out torque at rated voltage shall not be less than 205 % of full load torque.
12	Requirements during Starting & Running	<ul style="list-style-type: none">• Motor shall start with rated load and accelerate to full speed with 80 % rated voltage at motor terminals• The motor shall be capable of withstanding the stresses imposed if started at 110 % rated voltage.• The motor shall be capable of operating satisfactorily at full load for 5 minutes without injurious heating with 75 % rated voltage at motor terminals.
13	Momentary Overload withstanding capability	The motor shall be designed to withstand momentary overload of 60% of full load torque for 15 seconds without any damage.
14	Momentary Over speed Withstanding capability	The motor shall be designed to withstand 120 % of rated speed for 2 minutes without any mechanical damage.
15	Hot thermal withstand curve	Margin of at least 10% over the full load current
16	Class of Insulation	Class-F insulation with temperature rise limited to Class-B. Temperature rise of the motor shall be limited to 70° C (by resistance method) over an ambient temperature of 50° C.
17	Stress withstanding capability during Bus Transfer	The motor may be subjected to sudden application of 150 % rated voltage during bus transfer, due to the phase difference between the incoming voltage and motor residual voltage.
18	Capacity to restart for rated voltage	<ul style="list-style-type: none">a. Two successive starts from cold condition.b. Three equally spread starts per hour.c. Two hot starts in succession, with motor initially running at normal temperature.



Sl. No.	Description	Requirement
19	Starting Current	The starting current (% of FLC) shall be limited as per the standard IS-12615.
20	Locked Rotor Condition	<p>The ratio of Locked Rotor KVA at rated voltage to rated KW shall not exceed as indicated below (without any further tolerance)</p> <p>For Motor rating from 50 KW and up to 110 KW: 11</p>
21	Locked Rotor with-stand time	For motor with starting time up to 20 seconds at minimum permissible voltage during starting, the locked rotor withstand time under hot condition at highest voltage limit shall be at least 2.5 seconds more than starting time.
		For motor with starting time more than 20 seconds but not exceeding 45 seconds at minimum permissible voltage during starting, the locked rotor withstand time under hot condition at highest voltage limit shall be at least 5 seconds more than the starting time.
		For motor with starting time more than 45 seconds at minimum permissible voltage during starting, the locked rotor withstand time under hot condition at highest voltage limit shall be 10% more than the starting time
		Vendor to provide Speed switches mounted on the motor shaft in case the above requirement is not met with.
22	Type of balancing of rotor	Dynamic balancing
23	Method of cooling	IC-0411 as per IS-6362
24	Direction of cooling air flow	NDE side to DE Side
25	Winding wire	<p>Enameled Copper Wire, Grade-2, as per IS-13730, Part-3.</p> <p>Windings shall be non-hygroscopic, oil resistant and flame resistant.</p>
26	Treatment on Winding Insulation	Winding Insulation shall be given tropical and fungicidal treatment for operation of motor in hot, humid & tropical climate.



Sl. No.	Description	Requirement
27	Bearing	<p>Deep Groove Ball Bearing or Roller bearing as per the motor design, properly sealed to protect against the ingress of dust and water.</p> <p>Lubrication : Grease.</p>
28	Noise level	Noise level shall be limited to 85 dB at 1 meter distance.
29	Vibration level	The peak amplitude of vibration shall be as per IS-12075 (Limits of Severity-Normal grade shall be followed).
30	Shaft extension	Motor shall be provided with key slotted bare shaft extension, with key at the drive end.
31	Terminal box	<p>Weather proof terminal box shall be provided. The terminal box shall be capable of being turned through 360° in steps of 180° or 90°. Shall meet IP 55 protection class requirements as per IS 60529.</p> <p>Minimum Distance between center of the terminal stud & the gland plate and Minimum inter-phase/phase-earth air clearance shall be provided as per IS/IEC standards. Refer Project Specific transmittal for project specific requirements of dimensions.</p> <p>Terminal box shall have adequate space to terminate the Power cable applicable to the motor by using suitable lugs.</p> <p>Connection diagram shall be marked inside the terminal box.</p> <p>The terminal box shall be capable of withstanding a fault level of 50 kA rms for 1 second (Voltage : 415 V) at the terminals.</p>
32	Cable Entries, Cable Glands & Lugs	<p>Cable entries, Cable glands and Lugs shall be provided suitable for the power cable size, which will be indicated after PO placement during datasheet approval. Tentative sizes are indicated in the project specific transmittal.</p> <p>Double Compression type, brass with nickel plated, weather proof cable glands shall be provided – Quantity to be matched with the number of entries.</p> <p>6 Nos. of Tinned Copper Lugs shall be provided.</p>
33	Terminals	Separate Terminals for Space heaters and Windings with suitable connecting links shall be supplied.



Sl. No.	Description	Requirement
34	Earthing provisions	Earthing provisions shall be provided on motor body (2 nos. at opposite locations) and in terminal boxes as per the standard.
35	Space heater for motors rated 30 KW and above	Separate space heater suitable for 240 V AC, Single Phase supply shall be provided.
36	Lifting device	Eye bolt.
37	Project specific requirements	Vendor to take care of the project specific requirements indicated in the annexure - "Project specific transmittal".
38	Name Plates	Motor shall have name plate as per relevant IS and in addition, Manufacture's name, frame size, Energy Efficiency class, Insulation class, Bearing details, year of manufacture shall also be indicated.
39	Type test reports	<p>Type test reports shall be produced for the following tests as per the requirements spelt in the standards,</p> <ul style="list-style-type: none">• Measurement of resistance of windings of stator.• No load test at rated voltage to determine input current power and speed• Full load test to determine efficiency, power factor and slip.• Temperature rise test.• Momentary excess torque test.• High voltage test.• Test for vibration severity of motor.• Test for noise levels of motor.• Test for degree of protection.• Over speed test.• Energy Efficiency test. <p>In case the vendor is not able to submit report of the type test(s) conducted within last 5 years from the date of bid opening, or in case the type test report(s) are not found to be meeting the specification requirements, the vendor shall conduct all such tests either in an independent laboratory or at manufacturer's works in presence of Owner's representative under this contract, free of cost to the Owner and submit the reports for approval.</p>



Sl. No.	Description	Requirement
40	Confirmation and Documents to be submitted by the vendor, during Purchase Enquiry.	Vendor to indicate the references of the technical specification, project specific annexure and indicate "No Deviation" in the Sub-Delivery Enquiry deviation form. Any deviation shall only be indicated in the Sub-Delivery Enquiry deviation form. Deviations indicated elsewhere in the offer will not be considered.
41	Documents to be submitted by the vendor for approval by BHEL/Customer, after placement of purchase order.	3 Sets of the following: - a. Final technical Data sheet as per the format submitted by BHEL. b. Motor GA drawing indicating details of foundation, shaft dimensions and terminal box arrangement with complete dimensions. c. Motor Characteristic curves (Torque Vs. Speed, Current Vs. Speed, Speed Vs. time, Current Vs. time, Efficiency and PF Vs. load, Thermal withstand characteristic) d. O & M manuals.
42	Packing	The packing shall be suitable for safe transport, safe delivery at site and shall avoid damages due to environmental conditions during storage at site.
43	Painting	Paint shade shall be as per the purchase enquiry. The finish shall be corrosion resistant, epoxy based paint.

Taking care of the above indicated technical requirements in full, vendor to submit Sub-delivery enquiry deviation (SDED) format sent along with the purchase enquiry, without any deviations. Any deviation/clarification in the technical requirements has to be indicated only in the SDED format. Other than the SDED format, hidden deviations indicated elsewhere in the offer will not be considered.

Controls & Instrumentation/Fossil Boilers
Project Specific Transmittal for LT AC motors and DC motors

Transmittal Ref. : TR:LT AC MOTOR:NC-FGD

Project Details :

Project/Rating : NORTH CHENNAI TPS, 1 X 800 MW

Table - 1, Power cable size for LT AC motors: -

Vendor to provide the cable entry and supply cable-glands, lugs as per the technical specification requirement suitable for the power cable sizes as indicated below. The cable sizes indicated below are tentative. The actual power cable size based on the cable run length will be intimated during technical evaluation stage, before placement of purchase order.

Sl. No.	From (KW)	To (KW)	Power Cable size in sq. mm. (#)
1.	2.21	7.5	3C-16mm ² (AL)
2.	7.51	11.00	3C-16mm ² (AL)/3C-25 mm ² (AL)
3.	11.10	18.50	3C-25mm ² (AL)/3C-50 mm ² (AL)
4.	18.51	45.00	3C-50mm ² (AL)/3C-95 mm ² (AL)
5.	45.01	75.00	3C-95mm ² (AL)/3C-150 mm ² (AL)/3C-240 mm ² (AL)
6.	75.01	110.00	3C-150 mm ² (AL)/3C-240 mm ² (AL)

Table-2 (Applicable to LT AC Motors) :-

Sl. No.	Motor rating (KW)	Minimum Distance between centre of motor terminal and the gland plate (mm)
1	Up to 3 KW	As per manufacturers' practice
2	Above 3 KW – Up to 7 KW	85
3	Above 7 KW – Up to 13 KW	115
4	Above 13 KW – Up to 24 KW	167
5	Above 24 KW – Up to 37 KW	196
6	Above 37 KW – Up to 55 KW	249
7	Above 55 KW – Up to 90 KW	277
8	Above 90 KW – Up to 125 KW	331

Table-3 Applicable for LT AC motors :-

Minimum inter-phase and phase-earth air clearance for LT AC motors with lugs installed shall be as follow

Sl. No.	Motor MCR in KW	Clearance (in mm)
1	Up to 110 KW	10
2	Above 110 KW – Up to 150 KW	12.5

Note :

This document has to be referred along with the technical specification of the motor. If requirements of common features/points are spelt out in both, project specific transmittal and technical specification (TCI:140, Rev. 13), then the requirements indicated in project specific transmittal will supersede the respective clauses of the technical specification.



SECTION : 3.1- MOTORS

1.0.0 INTENT OF SPECIFICATION

This section covers the technical requirements of HT and LT Motors.

2.0.0 CODES AND STANDARDS

The equipment to be furnished under this specification shall be in accordance with the applicable section of the latest edition (including amendments) of the following Indian Standards (IS), IEC publications and other codes, especially the Indian Statutory Regulation, except where modified and /or supplemented by this specification.

- a) IS: 325 Three phase induction motors
- b) IS: 12615 Energy efficient induction motors
- c) IS: 900 Code of practice for installation and maintenance of induction motors
- d) IS: 996 Single-phase AC induction motor for general purpose
- e) IS: 1231 Dimensions of three-phase foot-mounted induction motors
- f) IS: 2223 Dimensions of flange mounted AC induction motors
- g) IS: 4029 Guide for testing three-phase induction motors
- h) IS: 8789 Values of performance characteristics for three-phase induction motors
- i) IS: 13555 Guide for selection and application of 3-phase AC induction motors for different types of driven equipment
- j) IS: 5571 Guide for selection of electrical equipment for hazardous areas
- k) IS: 12065 Permissible limits of noise level for rotating electrical machines
- l) IS: 12075 Mechanical vibration of rotating electrical machines
- m) IS: 9334 Electrical motor operated actuators
- n) IS 60034-5 Degree of protection provided by Integral design of rotating electrical machines
- o) IS 60034-8 Terminal marking and direction of rotation
- p) IS 60079-1 Equipment protection by flame proof enclosure
- q) IS 60034-1 Rotating electrical machines.
- r) IS 60079 Explosive atmospheres
- s) IS/IEC 60529 Degrees of protection provided by enclosures (IP code)
- t) IEC 60034 Rotating electrical machines.

3.0.0 TECHNICAL REQUIREMENTS

3.1.0 Design ambient temperature

Motors shall be suitable for an ambient temperature of 50 degree C and relative humidity of 95% and shall deliver the rated output without exceeding its guaranteed temperature limits. The equipment shall operate in highly polluted environment.

3.2.0 Supply voltage

Motors rated up to and including 415V are termed as LT motors and the motors rated higher than 415V are termed as HT motors.

Motors shall be capable of delivering the rated output under following voltage and frequency variations without exceeding its guaranteed temperature limits.



- Frequency variation : (+) 3% and (-) 5%
- Voltage variation for LT motors : (±) 10%
- ~~Voltage variation for HT motors : (±) 10%~~
- Combined variation of voltage and frequency : 10% (absolute sum)

All the motors shall be so designed that maximum inrush currents, locked rotor torque and pullout torque developed at extreme voltage and frequency variations do not endanger the motor and the driven equipment.

3.3.0 System Parameters

Sl. No.	Description	HT System	LT System
1.	Voltage level	11 KV Above 2000 KW 6.6KV above 160KW & upto 2000KW	240 V : up to 0.2 KW 415 V : >0.2 KW and up to 160 KW.
2.	System earthing	Earthed through resistance. Earth fault current : 300 Amps	415V: Solidly grounded.
3.	System fault level	50 KA for 3 sec for 11KV 40KA for 1sec for 6.6KV	50 KA for 1 second
4.	Fault withstand rating of motor terminal box (Breaker operated)	50 KA for 0.25 sec for 11KV 40KA for 0.25 sec for 6.6KV	50 KA for 0.25 second

3.4.0 Type

- AC Motors shall be squirrel cage induction type unless otherwise it is specified. All the motor shall be bi-directional.

3.5.0 Duty

- All AC motors shall be squirrel cage three phase/single phase induction motors. All the motor shall be designed for bi-directional rotation.
- Motors shall be suitable for installation in hot, humid and tropical atmosphere and polluted at places with coal ash and fly ash or any dusty chemical handling area.
- All LV motors above 10KW shall be with S1 duty.

3.6.0 Design margin

- Motor rating shall be selected higher than the maximum load demand of the driven equipment, as per the criteria stated in mechanical section of this specification, under entire operating range, including voltage and frequency variation.
- The motor name plate rating shall have 15% margin over duty point input (or) 10% margin over the maximum demand of driven equipment whichever is higher considering highest system frequency.
- The motor characteristics shall match the requirements of the driven equipment so that adequate starting, accelerating; pull up, breakdown and full load torques are available for the intended service.
- Service shall be considered as 1.0 only.



3.7.0 Method of Starting

- All the motors shall be suitable for direct on-line starting on full load.
- ~~HT Motors will be controlled through vacuum circuit breaker.~~
- LT motors rated less than 90KW will be controlled through MPCB/MCCB and contactor. LT motors rated 90 KW and above will be controlled through air circuit breaker (ACB).

3.8.0 Efficiency

All the continuous duty motors shall be energy efficient type. For LT motors, it shall be IE3 class as per IS 12615. For HT motors, efficiency shall be more than 95%.

3.9.0 Temperature rise

- Winding Insulation shall be Class F.
- Temperature rise of motors shall not exceed 70°C over air temperature of 50°C by resistance method, while delivering its maximum rated output.

3.10.0 Starting voltage

- a) Motors shall be capable of starting and accelerating the load at following starting voltage, with direct on line starting, without exceeding specified winding temperatures.
 - ~~HT Motors : 95% of rated voltage~~
 - LT motors : 80% of rated voltage
- b) During fast changeover of power supply source, vector difference between the motor residual voltage and the incoming supply voltage will be about 150% of the rated voltage and the motors shall withstand voltage stress and torque stress developed during that time, which may last for a period of one (1) second.
- c) The motor shall be capable of operating at full load at a supply voltage of 80% of the rated voltage for 5 minutes.
- d) The motor shall be capable of withstanding the stresses imposed if started at 110% rated voltage.
- e) Motor shall not stall if the supply voltage drops to 70% of the rated voltage two (2) second duration

3.11.0 No. of Starts

Continuous duty motors shall be suitable for the following starting requirements under the specified conditions of load, torque and inertia.

- No. of consecutive hot starts shall be 2 (with initial temperature of the motor at full load operating level).
- No. of consecutive cold starts shall be 3 (with initial temperature of the motor at ambient temperature).
- For conveyor motors, no. of consecutive hot starts shall be 3 (with initial temperature of the motor at full load operating level).



3.12.0 Starting current

- ~~Motor shall be designed for direct online starting at full voltage. Starting current shall not exceed 6 times full load current for all auxiliaries. No further tolerances are applicable on starting current specified above for HT motors.~~
- For LT motors, the applicable starting current shall be limited to 7.2 times of full load current including all tolerance.

3.13.0 Locked rotor withstand time

- ~~The locked rotor withstand time for HT motors under hot conditions at 110% rated voltage shall be more than the starting time at minimum permissible voltage specified above by atleast three seconds or 15% of the accelerating time whichever is greater.~~
- For the LT motors having starting time upto 20 seconds at minimum permissible voltage, the locked rotor withstand time under hot condition at highest voltage limit shall be at least 2.5 seconds more than the starting time.
- For the motors having starting time more than 20 seconds and up to 45 seconds at minimum permissible voltage, the locked rotor withstand time under hot condition at highest voltage limit shall be at least 5 seconds more than the starting time.
- For motors having starting time more than 45 seconds at minimum permissible voltage, the locked rotor withstand time under hot condition at highest voltage limit shall be more than starting time by at least 10% of the starting time.
- The motors shall be designed to withstand 120% of rated speed for 2 minutes without any mechanical damage
- All motors shall be so designed that maximum in rush currents and locked rotor and pull out torque developed by them at extreme voltage and frequency variation do not endanger the motor & driven equipment.

3.14.0 Torque Requirements

- Accelerating torque at any speed with the lowest permissible starting voltage shall be at least 10% motor full load torque.
- Pull out torque at rated voltage shall not be less than 205% of full load torque.
- Motors subjected to reverse rotation shall be designed to withstand the stresses encountered when starting with non-energized shaft rotating at 125% of rated speed in reverse direction.
- The motor shall be designed to withstand momentary overload of 60% of full load torque for 15 second without any damage.

3.15.0 Enclosure

- a) All motor enclosures shall conform to the degree of protection IP 55 unless otherwise specified. Motor for outdoor or semi outdoor service shall be of weather proof construction.
- b) For hazardous location, the enclosure of motors shall have flame proof construction conforming to applicable standard.



3.16.0 Cooling

- LT motors shall be totally enclosed fan cooled (TEFC), type IC411. The cooling shall be effected by self-driven bi-directional centrifugal fan protected by fan cover.
- ~~HT motors can be totally enclosed fan cooled (TEFC) or totally enclosed tube ventilated (TETV) or closed air circuit air cooled (CACA) type.~~
- Motors rated >3000KW can be closed air circuit water cooled (CACW).
- Motors with CACA/CACW heat exchangers shall have dial type thermometer with adjustable alarm contacts to indicate the following:
 - Hot and cold air temperatures of the closed air circuit for CACA motors.
 - Hot and cold, air and water temperatures for CACW motors.
- The Alarm switch contact rating shall be minimum 0.5 A at 220 V DC and 5A at 240 V AC.

3.17.0 Winding

- Winding shall be class F insulation with temperature limited to class B. Insulation shall be Non-hygroscopic, oil resistant, and flame resistant. Winding, fittings and hardware shall be corrosion resistant. Winding shall be tropicalized and suitably varnished, baked and treated for operating satisfactorily in humid and corrosive atmosphere.
- For the VFD operated drives, insulation shall be designed to take care of stresses due to high Dv/dt. Motors shall be wound with dual coated winding wires and impregnated with VPI process. Further for such application, insulated bearings shall be provided to avoid circulating current caused by shaft induced voltages.
- Space heaters rated for 240V AC, 50 Hz supply shall be provided for motors rated 30KW and above to maintain windings in dry condition when motor is standstill.
- For HT motors, insulation shall be Vacuum Impregnated (VPI).
- ~~HT motors shall withstand 1.2/50 microsec impulse Voltage wave of 4U+5 KV (U=Line voltage in KV). The coil inter-turn insulation shall be suitable for 0.3/3msec surge of 32KVp and 12KVp for 11KV & 6.6KV system respectively, followed by 1 min power frequency high voltage test of appropriate voltage on inter turn insulation.~~

Temperature Detectors

- ~~All 11KV motors shall be provided with six (6) nos. duplex, or twelve (12) nos. simplex type winding temperature detectors, i.e. two (2) nos. duplex or four (4) nos. Simplex per phase.~~
- ~~11KV motor bearing shall be provided with duplex type temperature detectors.~~
- ~~The temperature detector mentioned above shall be resistance type, 3 wire, platinum wound, 100 Ohms at 0°C.~~
- Leads of all simplex type motor winding RTDS and motor bearing RTDS shall be wired up to respective switchgear metering & protection compartment. From which one set of RTDS will be connected to numerical protection relay and another set shall be kept free for DCS/PLC connectivity.
- Five number of Temperature detectors / thermistors shall be provided for L.T. motors above 90 KW (3 numbers winding temperatures & 2 numbers bearing temperatures)



3.18.0 Bearings

- Motor shall be provided with antifriction bearings, unless sleeve bearings are required by the motor application. Bearings shall be provided with seals to prevent leakage of lubricant or entrance of foreign matters like dirt, water etc. into the bearing area.
- Sleeve bearings shall be split type, ring oiled with permanently aligned, close running shaft sleeves. Grease lubricated bearings shall be pre-lubricated and shall have provisions for in-service positive lubrication with grease nipple and relief holes.
- Vertical shaft motors shall be provided with thrust and guide bearings. Thrust bearing of tilting pad type is preferred. However, if anti-friction bearings can take vertical thrust, thrust and guide bearings are not required.
- Lubricant shall not deteriorate under all service conditions. The lubricants shall be limited to normally available types. For motors rated 30KW and above re-lubrication facility shall be provided.
- For motor with forced lubrication, a shaft driven oil pump shall be provided along with an electrical auxiliary pump. Alternatively, two motor driven pumps may be provided, one working and one standby. All necessary auxiliaries and accessories shall be provided to complete the system. A pressure gauge and pressure switch for low oil pressure warning and to start the standby oil pump automatically shall also be provided. A motor driven jacking oil pump may be provided, for heavy shaft loads.
- Flow switches shall be provided for monitoring oil flow of forced lubrication bearings, if used. Alarm switch contact rating shall be minimum 0.5 A at 220 V DC and 10A at 230 V AC.
- For bearing temperature measurement, duplex RTDs shall be provided for each bearing and shall be wired upto the terminal box.
- Each bearing shall be provided with dial type thermometer.
- ~~For all VFD operated motors and motors rated above 1000KW shall have insulated bearings to prevent flow of shaft currents.~~

3.19.0 Terminal Boxes

- For single core cables, gland plate shall be non-magnetic material. Terminal box shall be capable of being turned 360° in steps of 90°, unless otherwise approved. The terminal boxes shall be split type with removable cover with access to connections.
- Terminals for motors shall be stud type, thoroughly insulated from the frame. The terminals shall be clearly identified by phase markings, with corresponding direction of rotation marked on the non-driving end of the motor.
- The terminal box shall be capable of withstanding maximum system fault current for 0.25 sec for all breaker operated motors and shall be provided with explosion vent.
- For contactor operated LT motors, the terminal box shall be capable of withstanding the fault current for 0.2 sec minimum and operating time of MPCB/MCCB.
- Removable gland plates of thickness not less than 2.5 mm sheet steel or 3 mm aluminium (for single core cables) shall be provided for cable boxes.
- Cable spreader box shall be provided for larger cable sizes.



- Cable boxes of HT motors shall be phase segregated type. The terminals of three phases shall be segregated by barriers of metal or fibre glass. For HT motors, cable box design shall be suitable for accommodating cable termination kits.
- Separate terminal box for space heaters shall be provided.
- A separate terminal box of IP 55 degree of protection shall be provided for temperature detectors.
- Motor 1000 KW and above shall be provided with three differential current transformers mounted over the neutral leads within the enclosure. Loose 3 numbers CT for mounting on switchgear side shall be in bidder's scope. The arrangement shall be such as to permit easy access for C.T. testing and replacement. Current transformer characteristics shall match Owner's requirements to be intimated later to the successful bidder. The CT details shall be finalized during detail engineering. Neutral terminal box shall have IP 55 degree of protection.
- The secondary leads of CT shall be wired to separate auxiliary terminal box of IP 55 degree of protection
- All the accessory terminal boxes shall be located on the same side of the main (power) terminal box.
- For LT motors, terminal box shall be located on top, unless otherwise specified.

3.20.0 Earthing Terminals

The frame of each motor shall be provided with two separate and distinct grounding pads complete with tapped hole, GI bolts and washer. The terminal box shall have a separate grounding terminal.

The grounding connection shall be suitable for accommodation of ground conductors as follows :

Above 100 to 200 KW	: 75x10 mm GS flat
Above 55 KW to 100 KW	: 50x6 mm GS flat
Above 22 KW to 55 KW	: 50x6 mm GS flat
Above 5.5 KW to 22 KW	: 25x6 mm GS flat
Fractional HP LV Motors	: 8 SWG GS Wire

3.21.0 Noise and Vibration

- Motors shall be selected with low noise levels in accordance with IS 12065. Noise level for all motors shall be limited to 85db (A).
- The peak amplitude of the vibration shall also be within the specified limits of IS: 12075.
- All HT motors shall be provided with vibration pads for mounting vibration detectors. Motors shall withstand vibration produced by driven equipment.

3.22.0 Name Plates

Motor shall have stainless steel nameplate(s) showing diagram of connections, all particulars as per IS: 325 / IS: 12615 and shall also have 'BEE' marking.

In addition to the minimum information required by IEC/IS, the following information shall be shown on motor rating plate:

- Temperature rise in °C under rated condition and method of measurement.



- Degree of protection.
- Bearing identification no. and recommended lubricant.
- Location of insulated bearings.

3.23.0 Drain plug

Motor shall have drain plugs so located that they will drain the water, resulting from the condensation or other causes from all pockets of the motor casing.

3.24.0 Lifting provision

Motor weighing 25 Kg. or more shall be provided with eyebolt or other adequate provision of lifting.

3.25.0 Dowel pins

The motor shall be designed to permit easy access for drilling holes through motor feet or mounting flange for installation of dowel pins after assembling the motor and driven equipment

4.0.0 INSTALLATION

Installation shall be carried out as per IS: 900.

5.0.0 PAINTING

Painting shall be carried out by an approved process. Pretreatment shall conform to applicable standard. The equipment shall be subject to a coat of red oxide primer paint. All inside and outside surface shall be painted with epoxy based paint. The final thickness of paint film on steel shall not be less than 100 microns. Paint Shade for the Motor shall be RAL 7032 (Siemens Grey). Sufficient quantity of touch-up paint shall be furnished for application at site.

6.0.0 TESTING AND INSPECTION

- 6.1.0 Tests shall be performed in presence of Owner's representatives. Successful Bidder shall give atleast fifteen (15) days advance notice for witnessing the tests. Copies of certified reports of all tests carried out at the works shall be furnished. The equipment shall be dispatched from works, only after receipt of Owner's written approval of the test reports.
- 6.2.0 Routine and Type Tests are to be conducted for all HT motors and for LT motors above 60 KW rating in presence of customer's representative as per IS:325, IS:4722, IS:9283 and required copies of test certificates are to be furnished for approval.
- 6.3.0 Test certificates for Routine tests conducted as per IS:325, IS:4722, IS:9283 for motors of rating 60 KW and below shall be submitted for TANGEDCO review, approval and dispatch clearance.
- 6.4.0 The following minimum tests/ checks shall be conducted at site. Any other tests/ checks as per the manufacturer's recommendation shall also be carried out
- i) Measurement of vibration.
 - ii) Measurement of insulation resistance and polarization index
 - iii) Measurement of full load current.
 - iv) Test running of the motors, checking the temperature rise and identifying the hot spot etc.



7.0.0 OTHERS

- 7.1.0 The responsibility of co-ordination with electrical agencies and obtaining all necessary clearances shall be the contractor.
- 7.2.0 Canopy shall be provided for outdoor motors.
- 7.3.0 Contractor shall provide fully compatible electrical system, equipment, accessories and services.

Supplier Logo		MANUFACTURING QUALITY PLAN (* Indicative*)						PROJECT: PACKAGE: FGD PACKAGE						
		Manufacturer Name and Address				ITEM: AGITATOR		CONTRACT No.:						
						QP NO: ,REV:0 DT:		CUST No:						
						Page 1 of 2		Contractor- BHEL						
SL. NO.	COMPONENT OPERATION	CHARATERISTICS	CLASS	TYPE OF CHECK	QUATUM OF CHECK		REFERENCE DOCUMENT	ACCEPTANCE NORMS	FORMAT OF RECORD		AGENCY			REMARKS
					M	C/N				D*	M	C	N	
1	2	3	4	5	6		7	8	9	D*	10			11

1.0	Raw Material Inspection													
1.1	All materials including casting & forgings	Chem. & Mech. Dimensions Surface Defects	MA MA MA	Review of MTC Measurement Visual	1/Heat 100% 100%	1/H eat - -	As per Spec. & Appd. Dwg.	TC IR IR	√	P P P	V - -	V - -		
2.0	Motor: Review of Manufacture Test Certificate													
3.0	In Process Inspection													
3.1	Welding Qualifications	WPS & PQR	MA	WPS, PQR & WPQ	100%		ASME Sec IX	IR	√	P	V	V	Recent qualified WPS,PQR and WPQ shall be submitted for review during inspection.	
3.2	Marking, Cutting, Edge Preparation Tacking	Dimensions	MA	Measurement	100%	-	Appd. Dwg.	IR		P	-	-		
3.3	Welds	Dimensions & Surface Quality	MA	Measurement & Visual	100%		Appd. Dwg. & .ASME Sec VIII	IR	√	P	W	V		
3.4	Machining of Components	Dimensions Surface Defects	MA	Measurement Visual	100% 100%	- -	Appd. Dwg.	IR		P P	- -	- -		
3.5	Impeller	Static balance test	MA	Measurement	100%		As per Specs.	TR	√	P	V	V		
3.6	Rubber Lining	Spark test, Hardness, Adhesion test, Coating thickness, High voltage porosity test	MA	Measurement	100%		As per Specs./ Appd Dwg & Data sheet	TR	√	P	W	V		
3.7	Assembly	Dimensions Completeness	MA	Measurement Visual	100% 100%		Appd.Drg.	IR	√	P P	V V	V V		
4.0	Final Inspection													
4.1	Final Assembly	Overall Dimensions & Completeness	MA MA	Measurement Visual	100%	10%	Appd.Drg. & Spec.	IR	√	P	W	V		

MANUFACTURER	Prepared by	LEGEND: * RECORDS, IDENTIFIED WITH "TICK" (√) UNDER COLUMN 'D'SHALL BE SUBMITTED TO CUSTOMER AS A QA DOCUMENTATION PACKAGE. M: MANUFACTURE/SUB SUPPLIER, C MAIN CONTRACTOR/ N: NTPC/ P: PERFORM W: WITNESS AND V: REVIEW OF RECORDS			
	Approved by				
SIGNATURE			FOR CUSTOMER USE	REVIEWED BY	APPROVED BY

Supplier Logo		MANUFACTURING QUALITY PLAN (* Indicative*)						PROJECT: PACKAGE: FGD PACKAGE						
		Manufacturer Name and Address				ITEM: AGITATOR		CONTRACT No.:						
						QP NO: ,REV:0 DT:		CUST No:						
						Page 2 of 2		Contractor- BHEL						
SL. NO.	COMPONENT OPERATION &	CHARATERISTICS	CLASS	TYPE OF CHECK	QUATUM OF CHECK		REFERENCE DOCUMENT	ACCEPTANCE NORMS	FORMAT OF RECORD		AGENCY			REMARKS
					M	C/N				D*	M	C	N	
1	2	3	4	5	6		7	8	9	D*	10			11

4.2	Free Air Run Test of complete assembly	Measurement Current, RPM, Noise & Vibration	MA	Measurement	100%	10%	Vendor Standard / Approved Drawing / Data Sheet	IR	√	P	W	W	
4.3	Review of QA Documents	Verification of QA Documents	MA	Verification	100%	100%	As per Appd.MQP	IR		P	V	V	
5.0	Painting & Preservation												
5.1		Painting material	MI	Review of MTC	100%		Appd. "Painting Procedure" / Approved Painting Schedule	IR	√	P	V	-	
5.2		Surface treatment and inspection	MI	Visual	100%	-	-do-	IR	√	P	-	-	
5.3		DFT Check	MI	Measurement	10%		-do-	IR	√	P	V	-	
5.4		Painting Surface Quality	MI	Visual	100%		-do-	IR	√	P	V	-	
6.0	Inspection before Delivery												
6.1	Packing	Size, appearance & firmness	MI	Measurement & Visual	100%		As per "Packing Procedure"	IR	√	P	V	-	
6.2	Deliver Documents	Markings, Packing List & Detail Packing List, etc. Check	MI	Verification	100%		As per "Packing Procedure"	IR	√	P	V	-	

NOTES:

- For Agitator Motor rating is 45KW and motor make NTPC/BHEL Approved source.
- Routine test report duly witnessed by main contractor as per applicable standard shall be reviewed during inspection (more than 30KW Rating).

****The above mentioned QP is for reference purpose only and is not exhaustive. Engineering Technical specification is the base document for QP. All relevant points of Technical Specification shall be addressed in the Final MQP. The MQP approval will be given only post-contract stage and is subject to the addition of inspection stages or quantum by the customer and shall be performed by the Supplier without any cost/delivery implication ****

MANUFACTURER	Prepared by	LEGEND: * RECORDS, IDENTIFIED WITH "TICK" (√) UNDER COLUMN 'D' SHALL BE SUBMITTED TO CUSTOMER AS A QA DOCUMENTATION PACKAGE. M: MANUFACTURE/SUB SUPPLIER, C MAIN CONTRACTOR/ N: NTPC/ P: PERFORM W: WITNESS AND V: REVIEW OF RECORDS			
	Approved by				
SIGNATURE			FOR CUSTOMER USE	REVIEWED BY	APPROVED BY



ANNEXURE - XI
MANDATORY SPARES FOR FGD ABSORBER AGITATOR

PROJECT : NORTH CHENNAI FGD 1 (1X800MW)

REFERENCE: 8216/FJ365/Mandatory Spares/01

Enquiry No:

Agitator Model:

S.NO	BHEL MATERIAL CODE	ITEM DESCRIPTION	REQUIRED QUANTITY	APPLICABILITY	Bidder Item Description	Model/Part no/Type	SET Details indicating the qty in nos.	Remarks
1		Impeller Assembly	1 no. of each type and size					
2		Bearing Assembly	1 no. of each type and size					
3		Motor	1 no. of each type and size					
4		Belt and Pulley (If applicable)	1 no. of each type and size					
5		Gear Box Assembly (If Applicable)	1 no. of each type and size					
6		Agitator shaft assembly	1 no. of each type and size					
7		Shaft seal	1 no. of each type and size					
8		Complete Agitator assembly	1 no. of each type and size					

NOTE:

1. Bidder to clearly mention the SET details in against each item, indicating item description & Qty in nos.
2. Bidder shall furnish item covered in an assembly with item description, qty in nos.

ANNEXURE –XII - FGD ABSORBER AGITATOR – Checklist Cum Datasheet

PROJECT: TANGEDCO 1X800 MW AT NORTH CHENNAI FGD SYSTEM PACKAGE

REF NO: FGD/AGITATOR/CCD/8216

A. MANDATORY DOCUMENTS TO BE SUBMITTED ALONG WITH OFFER

SL. NO	PURPOSE	DESCRIPTION	VENDOR ACCEPTANCE/ COMMENTS
1	Qualification requirements	Supporting Documents for meeting the Technical PQR as per Annexure - X	
2	Compliance to the technical specification	The following technical documents provided along with the enquiry shall be signed with seal , indicating the full compliance of the bidder. i. Complete Specification along with Annexures ii. Typical Arrangement of side entry agitator drawing iii. Technical Information for sizing of Absorber Agitators iv. C&I Technical Specification of Motors - Annexure-VII v. Quality Plan (Annexure – VIII)	
3	Deviations	Deviation in specification shall not be entertained, however in case of any deviation, the same shall be listed in “List of Deviations”- Annexure-VI . Deviation mentioned in any other document shall not be considered applicable.	
4	Technical Evaluation	GA drawing with exploded view with dimensions, material of construction, total weight etc. Bidder to comply the Agitator assembly “Height Limitation” in line with the “Typical Arrangement of side entry agitator drawing” .	
5		Duly filled, Schedule of Guarantees as per Annexure-V	
6		Duly filled, Mandatory Spare list as per Annexure-XI	
7		List of Start-up & Commissioning Spares	
8		List of Special Tools	
Important Note: Offers containing partial or Incomplete documents are liable for rejection.			

B. DATASHEET

S.NO	PARAMETER	UNIT	DATA TO BE FILLED BY BIDDER
1	Tank Size [WXDXH]	Metres	23.9WX9.9DX5.0H
2	Tank Volume	m ³	At Normal liquid level [5M]: 1183.05M ³ At Maximum liquid Level [6M]: 1419.66M ³
3	No: of Agitator per Tank	No	2
4	Model no. of Agitator		
5	Type of Impeller		
6	No. of stages of Impellers	No	
7	No. of blades per Impeller	No	
8	Impeller Diameter	mm	
9	Impeller Speed	RPM	
10	Agitator Pumping Capacity	m ³ /min	
11	Volume Per Agitator	m ³	
12	Mechanical Seal Type		
13	Motor Rating	Kw	
14	MOC of the following		Bidder MOC
14.1	Blade of impeller	Alloy 926 or better material	
14.2	Hub of impeller		
14.3	Shaft		
14.4	Mounting base/Fasteners in Wetted parts		
14.5	Fasteners in Non Wetted parts	GI fastener (40 μ plated) /SS	
14.6	Mechanical seal	Super Duplex 2507 or better	
14.7	Flush pipe for Start-up with flanges	FRP or Alloy 926 or Alloy 59	

Bidder Sign with Seal and Date