

BUYERS SPECIFIC ADDITIONAL TERMS & CONDITIONS
ITEM NAME: PRESSURE GAUGE
PROJECTS: SIPAT STPP STG-III, SINGARENI AND YAMUNA NAGAR

SCOPE OF ENQUIRY:

E-bids on GeM portal are invited from bidders for the supply of PRESSURE GAUGE for SIPAT STPP STG-III, SINGARENI AND YAMUNA NAGAR as per requirement mentioned below:

Sl. No.	Material Code & Item Description	Total Quantity	Projects	LOT Quantity	Delivery Requirement
1.	HW7310198077 PRESSURE GAUGE AR-150; RANGE: 0-16 BAR AND SPECIFICATION - HW7310198.615 / ST48001.615 SPEC: HW7310198 REV: 06 SIZE: HW7310198.615	13 No.	NTPC SIPAT STPP STG-III	4 No.	05/11/2027
			SINGARENI TPP	4 No.	29/07/2027
			YAMUNA NAGAR	4 No.	30/04/2027
			YAMUNA NAGAR MANDATORY SPARE	1 No.	30/04/2027
2.	HW7310198085 PRESSURE GAUGE AR-150; RANGE: - 1 TO + 15 BAR AND SPECIFICATION - HW7310198.607 / ST48001.607 SPEC: HW7310198 REV: 06 SIZE: HW7310198.607	4 No.	NTPC SIPAT STPP STG-III	1 No.	05/11/2027
			SINGARENI TPP	1 No.	29/07/2027
			YAMUNA NAGAR	1 No.	30/04/2027
			YAMUNA NAGAR MANDATORY SPARE	1 No.	30/04/2027
3.	HW7310198093 PRESSURE GAUGE AR-150; RANGE: 0 TO 6 BAR AND SPECIFICATION -HW7310198.613 / ST48001.613 SPEC: HW7310198 REV: 06 SIZE: HW7310198.613	4 No.	NTPC SIPAT STPP STG-III	1 No.	05/11/2027
			SINGARENI TPP	1 No.	29/07/2027
			YAMUNA NAGAR	1 No.	30/04/2027
			YAMUNA NAGAR MANDATORY SPARE	1 No.	30/04/2027
4.	HW7310198107 PRESSURE GAUGE AR-150; RANGE: 0 TO 250 BAR AND SPECIFICATION - HW7310198.621 / ST48001.621 SPEC: HW7310198 REV: 06 SIZE: HW7310198.621	4 No.	NTPC SIPAT STPP STG-III	1 No.	05/11/2027
			SINGARENI TPP	1 No.	29/07/2027
			YAMUNA NAGAR	1 No.	30/04/2027
			YAMUNA NAGAR MANDATORY SPARE	1 No.	30/04/2027
5.	HW7310198115 PRESSURE GAUGE AR-150; RANGE: 0 TO 10 BAR AND SPECIFICATION - HW7310198.614 / ST48001.614 SPEC: HW7310198 REV: 06 SIZE: HW7310198.614	19 No.	NTPC SIPAT STPP STG-III	6 No.	05/11/2027
			SINGARENI TPP	6 No.	29/07/2027
			YAMUNA NAGAR	6 No.	30/04/2027
			YAMUNA NAGAR MANDATORY SPARE	1 No.	30/04/2027

1. Project Detail with consignee address:

[A] Project Name	SIPAT STAGE-III (1X800 MW)
Consignee Address	Head of Project Sipat Super Thermal Power Project, Stage-III (1X800 MW) P.O : Ujjwal Nagar, District : Bilaspur Chhatisgarh - 495555
[B] Project Name	1X800MW SINGARENI TPP SCCL
Consignee Address	The Project Manager, 1x800mw Singareni Thermal Power Plant Stage-2, Pegadapally (Village), Jaipur (Mandal), Mancherial (Dist), 504216 Telangana
[C] Project Name	1X800MW YAMUNA NAGAR HPGCL
Consignee Address	OFFICE OF CHIEF ENGINEER/DCRTPP, HARYANA POWER GENERATION CORPORATION LIMITED (HPGCL), 1X800 MW ULTRA SUPERCRITICAL EXPANSION UNIT, DEEN BANDHU CHHOTU RAM THERMAL POWER PLANT (DCRTPP), VPO- PANSARA, YAMUNA NAGAR, HARYANA-135001, INDIA

3. BUYERS SPECIFIC ADDITIONAL TERMS & CONDITIONS IN ADDITION TO GTC

Sl. No.	Terms	Description	Supplier confirmation
1.	Special Instruction	Please provide 8 digit HSN code for Pressure Gauge along with spares.	
2.	Documents Checklist:	<p>Please submit signed and stamped copy of your offer on each page along with following documents;</p> <ul style="list-style-type: none"> • Buyer Specific T&C. • Technical PQR & its supportive document. • Technical drawing & purchase specification. • Certificate/self-certification for minimum local content as per PPP-MII order. • Replica of price bid schedule without prices with part-I offer. 	
3.	Special Instruction of Technical requirement	IN ADDITION TO PACKING INSTRUCTIONS GIVEN IN SPEC. NO. ST48001 (CL. NO. 8.0), SPEC NO. ST33002 (CL. NO. 3.1 A & 3.2 B) SHOULD BE FOLLOWED FOR PACKING OF ALL ITEMS.	
		ITEM SHALL BE DISPATCHED IN SUITABLE "WOODEN BOXES WITH MULTIPLE STEEL STRIPS AROUND " WHICH CAN WITHSTAND TRANSIT MOVEMENT, LOCAL ENVIRONMENT AND MOISTURE/ WATER.	
		FOR ITEM WITH MATERIAL CODE: HW7310198077 FOR MAIN ITEM: FOLLOWING KKS TAGS TO BE PUNCHED ON RESPECTIVE TAG PLATES for SIPAT STPP STG-III, SINGARENI AND YAMUNA NAGAR are MAG10CP511, MAG10CP512, MAG10CP501, MAG20CP502	
		FOR ITEM WITH MATERIAL CODE: HW7310198085 FOR MAIN ITEM: FOLLOWING KKS TAGS TO BE PUNCHED ON RESPECTIVE TAG PLATES for SIPAT STPP STG-III, SINGARENI AND YAMUNA NAGAR are MAC01CP501	
		FOR ITEM WITH MATERIAL CODE: HW7310198093 FOR MAIN ITEM: FOLLOWING KKS TAGS TO BE PUNCHED ON RESPECTIVE TAG PLATES for SIPAT STPP STG-III, SINGARENI AND YAMUNA NAGAR are MAV86CP511	
		FOR ITEM WITH MATERIAL CODE: HW7310198107 FOR MAIN ITEM: FOLLOWING KKS TAGS TO BE PUNCHED ON RESPECTIVE TAG PLATES for SIPAT STPP STG-III, SINGARENI AND YAMUNA NAGAR are MAV67CP505	
		FOR ITEM WITH MATERIAL CODE: HW7310198115 FOR MAIN ITEM: FOLLOWING KKS TAGS TO BE PUNCHED ON RESPECTIVE TAG PLATES for SIPAT STPP STG-III, SINGARENI AND YAMUNA NAGAR are MAV41CP501, MAV41CP502, PGB11CP501, PGB11CP502 PGB12CP501, PGB12CP502	
		FOR ITEM AGAINST MANDATORY SPARE FOR YAMUNANAGAR PROJECT RESPECTIVE RANGE OF THE ITEM/ MATERIAL CODE TO BE PUNCHED ON THE TAG PLATE AND THIS ITEM AND THESE ITEM SHALL BE PACKED SEPERATELY IN A GREEN COLOURED PAINTED " WOODEN BOX WITH MULTIPLE STEEL STRIPS AROUND " WHICH CAN WITHSTAND TRANSIT MOVEMENT LOCAL ENVIRONMENT AND MOISTURE/ WATER FOR RESPECTIVE WO.	
		FOR PREFIX IN TAGS (IF APPLICABLE) , SHALL BE INFORMED DURING DRAWING APPROVAL.	
	THESE KKS TAGS SHALL ALSO BE LISTED ON DRAWINGS/ DATASHEETS IN CASE OF P.O		
4.	Quality Requirement	VENDORS TO SUBMIT ENDORSED COPY OF THE BHEL SQP QA/BE/QP/913, REV. 04. ALONG WITH OFFER.	
		VENDORS HAS TO CONFIRM FOR INSPECTION BY BHEL/BHEL TPIA M/S. QUEST AS PER ATTACHED BHEL SQP QA/BE/QP/913, REV. 04.	
		The Charges for Pre-Inspection would be borne by BHEL. However at least 15 days' notice is to be provided for arranging Pre-Inspection.	
5.	Compliance of GTC on GeM	General Terms and Conditions on GeM 4.0 (Version 1.29) Dtd -25/03/2026 or it's latest revision on GeM portal shall be applicable against this enquiry. Kindly confirm to compliance the same for this tender.	
6.	Pre-Qualification Requirements	The Pre-Qualification Requirements have been compiled. All the bidders should ensure submission of complete details and documents as called for in these requirements. The Offers submitted by the bidders would be scrutinized with respect to Pre-Qualification Requirements first. Techno-Commercial offer of only those bidders shall be evaluated who meet the Pre-Qualification Requirements.	
7.	Make in India Clause	"For this procurement, the local content to categorize a supplier as a Class I local supplier/ Class II local Supplier/ Non-local supplier and purchase preference to Class I local supplier, is as defined in Public Procurement (Preference to Make in India), Order 2017 dated 19.07.2024 issued by DPIIT. In case of subsequent orders issued by the nodal ministry, changing the definition of local content for the items of the NIT, the same shall be applicable even if issued after issue of this NIT, but before opening of Part-II bids against this NIT".	

		As per Make in India Order, only Class-1 and Class-2 local supplies are eligible to bid in this tender enquiry. For this eligibility criteria, bidders are required to submit certificate of Minimum local content as specified in attached Make In India Declaration format.	
8.	Compliance of Rule 144 (xi) of GFR 2017	Compliance of Restrictions under Rule 144 (xi) of GFR 2017 shall be as per GeM.	
9.	Bid validity/ Validity of offer	Please note that validity of the offer shall be 180 days from the date opening of Techno-Commercial bid (Part-I bid) on GeM portal. Offer of bidder's having validity less than 180 days shall liable to reject. Please confirm. The required validity is considering that offer is complete & clear w.r.t. PQR and all techno-commercial conditions. Vendors need to extend their offer validity for the time taken by them in responding BHEL's comments/clarification sought during techno-commercial scrutiny of the offer. In case regret by any bidder for such validity extension, their offer shall liable to be reject. Please confirm.	
10.	Loading and unloading	Vendor's scope will not cover Loading & Unloading at Final destination of delivery. Unloading at final destination (i.e. BHEL site) is in BHEL 'scope. Loading and unloading at other intermediate places due to any permitted transshipment will be the responsibility of the vendor. Kindly note	
11.	Prices/Basis of Quotation	The offered prices of the items shall remain firm and fixed till the execution of the contract, kindly confirm. Kindly confirm that your quote prices are inclusive of P&F, Freight & GST for Total quantity on GeM portal. Transit Insurance would be arranged by BHEL. Please quote your prices accordingly. Delivery Term shall be Ex-Works with freight Pre-paid up to project destination basis. Bidders can dispatch goods through any Indian Bank Association approved transporters having their branch at HARIDWAR / destination. If material is dispatched through other than Indian Bank Association approved transporter, material to be delivered on door delivery basis. In case of dispatch of material through any other unapproved transporter, payment shall be made only after receipt of material and any additional charges payable to the transporter shall be to the bidder's account. Any demurrage / godown rent payable to the transporter /or to godown's owner due to any delay attributed by the supplier shall be recovered from supplier's account	
12.	Special Instructions:	<u>SIPAT STPP STG-III, SINGARENI AND YAMUNA NAGAR projects:</u> <ul style="list-style-type: none"> • Please inform 8 digit HSN code for Pressure Gauge along with spares. • 08 DIGIT GST HSN CODE to be provided & mentioned in your invoice & packing list. • ORIGINAL (GR/LR , MDCC, PKG LIST) ARE REQUIRED FOR BILLING. • MATERIAL IS TO BE DESPATCHED ON DOOR DELIVERY BASIS TO SITE. • BHEL BBU NOS. TO BE MENTIONED IN PACKING LIST BY VENDOR. • Original (Invoice, GR/LR, Bill of Lading (if applicable), Air Way Bill (if applicable), Pkg. List, Certificate of origin (if applicable), E-Way bill are required for billing. • <u>For Yamuna Nagar Project-</u> Mandatory spares need to be packed in separate boxes. Mandatory spares to be written in Bold Letters on all sides of packing boxes. Mandatory spares are to be supplied along with Main Equipment but mandatorily in separate box. The packing list item description are in accordance with the approved BBU or Correlation Certificate approved by Engineering is required for MDCC and billing. • Vendor to ensure submission billing documents in the same month of material despatch. If vendor fail to provide the despatch documents in the same month GST Penalty shall be applicable and bear by vendor as per GST rule. 	
13.	Evaluation criteria	Evaluation would be done on the basis of total landed cost for the complete scope/requirement covered in the enquiry.	
14.	Evaluation Currency	The evaluation currency for this tender shall be INR.	

15.	Payment terms:	<p>The payment shall be done after receipt of Material at BHEL respective project site, within no. of days as defined in the below table from the date of receipt of Material at site i.e. MRC date).</p> <table border="1" data-bbox="370 142 1240 312"> <thead> <tr> <th>Type of Bidder</th> <th>Payment Terms (Number of Days)</th> </tr> </thead> <tbody> <tr> <td>Micro & Small Enterprises (MSEs)</td> <td>45 days</td> </tr> <tr> <td>Medium Enterprises</td> <td>60 days</td> </tr> <tr> <td>Non MSME</td> <td>90 days</td> </tr> </tbody> </table> <p>The Payment terms are subject to receipt of non-discrepant document from supplier. Note: <i>This is in supersession of 10 days' time as provided in Clause 12 of GeM GTC and also 45 days from CRAC as provided in the standard format of GeM Bid under Payment Timelines.</i></p>	Type of Bidder	Payment Terms (Number of Days)	Micro & Small Enterprises (MSEs)	45 days	Medium Enterprises	60 days	Non MSME	90 days	
Type of Bidder	Payment Terms (Number of Days)										
Micro & Small Enterprises (MSEs)	45 days										
Medium Enterprises	60 days										
Non MSME	90 days										
16.	GeM charges	GeM charges if any shall be either side only i.e. buyer's GeM charges shall be in buyer's account and seller's GeM charges shall be on seller's account. Please confirm.									
17.	Contract execution	Bidder's are advised to read GeM related query & clarification carefully on GeM portal. Order shall be executed through GeM.									
18.	Reverse Auction (E-bidding)	BHEL shall be resorting to Reverse Auction (RA) on GEM portal as per GEM functionalities for this tender. RA shall be conducted among the techno-commercially qualified bidders.									
19.	Quantity Variation	<p>BHEL reserves the right to cancel tender or reject any or all the quotations without assigning any reasons thereof.</p> <p>BHEL also reserves the right to increase or decrease the tendered quantities or quantity of individual material code may be dropped as a whole also.</p> <p>Vendors should be prepared to accept order for reduced Quantity without any extra charges. Vendor should also be prepared for giving discount in case of Increase in Quantity.</p> <p>Vendor has to take manufacturing clearance from BHEL before starting manufacturing of material. In case ordered quantity is reduced at the time of manufacturing clearance, then payment shall be made accordingly as per decreased quantity. Kindly confirm.</p>									
20.	Delivery Period	<p>Please note that BHEL's Delivery requirements are mentioned above under heading Scope of Enquiry. Early delivery w.r.t. above lot delivery will be accepted only after written confirmation from BHEL. BHEL reserve right to reject early delivery request of bidders / suppliers.</p> <p>Delivery period indicated in GeM bid is only indicative and final delivery of tender shall be taken as mentioned above.</p> <p>Accordingly bidders to confirm the above deliveries or quote their best possible delivery in no of months / weeks from the date of placement of Purchase order, including all activities like document approval, inspection by TPI time etc.</p>									
21.	Technical Document/ Drawing approval conditions	<p>Drawings/Data sheets/documents/QAP etc. as called for in the specifications shall be submitted by Vendor for BHEL/ Customer approval within 30 days of purchase order. BHEL shall approve these drawings/data sheets/ documents / QAP etc. within 30 days of receipt.</p> <p>Any comments on the documents shall be given by BHEL within 7 days of submission and vendor shall submit revised document / reply to comments, within 7 days of BHEL comments. However, total time for Document submission and approval shall not exceed 30 days for respective party.</p> <p>Delivery is from the date of PO, accordingly, delay in submission / revision of the documents by the vendor will automatically account for to vendor. In case of delay on account of BHEL in comments / approval of the documents, the delivery shall be re-scheduled by the no of days taken by BHEL in excess to 30 days. For delay analysis cumulative no of days (including time taken in comments), shall be considered for delivery extension.</p>									
22.	Liquidated Damages (LD) for late delivery	<p>Liquidated Damages shall be lot wise as per clause no. 15 (iii) of General terms and conditions on GeM 4.0 (Version 1.29) as under: kindly confirm.</p> <p>"If the Seller/Service Provider fails to deliver any or all of the Goods/Services within the original/re-fixed delivery period(s) specified in the contract, the Buyer will be entitled to deduct/recover the Liquidated Damages for the delay, unless covered under Force Majeure conditions aforesaid, @ 0.5% of the contract value of delayed quantity per week or part of the week of delayed period as pre-estimated damages not exceeding 10% of the contract value of delayed quantity without any controversy/dispute of any sort whatsoever".</p> <p>The date of LR would be treated as the date of delivery for penalty purposes.</p>									

23.	MDCC clause	<p>Please note that, material shall be dispatched only after issue of Material dispatch clearance certificate (MDCC) from end customer. For issue of MDCC, vendors are required to submit all test certificates (TC) and inspection report of third party (IR) to BHEL. After review & acceptance of the quality document, BHEL will forward the same to end customer for issuance of MDCC. MDCC shall be issued within 7 days of receipt of complete quality documents / TCs,. In case of delay in issuance of MDCC, only delivery shall be extended by no of days taken by BHEL in excess to 7 days and all other terms and conditions of PO shall remains same & binding.</p> <p>In case any material is dispatched without MDCC and any loss is incurred by Supplier/Vendor for any reason whatsoever, BHEL shall not be responsible in any manner to compensate the supplier in this regard.</p> <p>Kindly confirm.</p>	
24.	BREACH OF CONTRACT, REMEDIES AND TERMINATION:	<p>The following shall amount to breach of contract:</p> <p>I. Non-supply of material/ non-completion of work by the Supplier/Vendor within scheduled delivery/ completion period as per contract or as extended from time to time.</p> <p>II. The Supplier/Vendor fails to perform as per the activity schedule and there are sufficient reasons even before expiry of the delivery/ completion period to justify that supplies shall be inordinately delayed beyond contractual delivery/ completion period.</p> <p>III. The Supplier/Vendor delivers equipment/ material not of the contracted quality.</p> <p>IV. The Supplier/Vendor fails to replace the defective equipment/ material/ component as per guarantee clause.</p> <p>V. Withdrawal from or abandonment of the work by the Supplier/Vendor before completion as per contract.</p> <p>VI. Assignment, transfer, subletting of Contract by the Supplier/Vendor without BHEL's written permission resulting in termination of Contract or part thereof by BHEL.</p> <p>VII. Non-compliance to any contractual condition or any other default attributable to Supplier/Vendor.</p> <p>VIII. Any other reason(s) attributable to Vendor towards failure of performance of contract. In case of breach of contract, BHEL shall have the right to terminate the Purchase Order/ Contract either in whole or in part thereof without any compensation to the Supplier/Vendor.</p> <p>IX. Any of the declarations furnished by the contractor at the time of bidding and/ or entering into the contract for supply are found untruthful and such declarations were of a nature that could have resulted in non-award of contract to the contractor or could expose BHEL and/ or Owner to adverse consequences, financial or otherwise.</p> <p>X. Supplier/Vendor is convicted of any offence involving corrupt business practices, antinational activities or any such offence that compromises the business ethics of BHEL, in violation of the Integrity Pact entered into with BHEL has the potential to harm the overall business of BHEL/ Owner.</p> <p>Note-Once BHEL considers that a breach of contract has occurred on the part of Supplier/Vendor, BHEL shall notify the Supplier/Vendor by way of notice in this regard. Contractor shall be given an opportunity to rectify the reasons causing the breach of contract within a period of 14 days. In case the contractor fails to remedy the breach, as mentioned in the notice, to the satisfaction of BHEL, BHEL shall have the right to take recourse to any of the remedial actions available to it under the relevant provisions of contract.</p> <p>Remedies in case of Breach of Contract.</p> <p>i) Wherein the period as stipulated in the notice issued under above clause has expired and Supplier/Vendor has failed to remedy the breach, BHEL will have the right to terminate the contract on the ground of "Breach of Contract" without any further notice to contractor.</p> <p>ii) Upon termination of contract, BHEL shall be entitled to recover an amount equivalent to 10% of the Contract Value for the damages on account of breach of contract committed by the Supplier/Vendor. This amount shall be recovered by way of encashing the security instruments like performance bank guarantee etc available with BHEL against the said contract. In case the value of the security instruments available is less than 10% of the contract value, the balance amount shall be recovered from other financial remedies (i.e. available bills of the Supplier/Vendor, retention amount, from the money due to the Supplier/Vendor etc. with BHEL) or the other legal remedies shall be pursued.</p> <p>iii) wherever the value of security instruments like performance bank guarantee available with BHEL against the said contract is 10% of the contract value or more, such security instruments to the extent of 10% contract value will be encashed. In case no security instruments are available or the value of the security instruments available is less than 10% of the contract value, the 10% of the contract value or the balance amount, as the case may be, will be recovered in all or any of the following manners:</p>	

		<p>iv) In case the amount recovered under sub clause (a) above is not sufficient to fulfil the amount recoverable then; a demand notice to deposit the balance amount within 30 days shall be issued to Supplier/Vendor.</p> <p>v) If Supplier/Vendor fails to deposit the balance amount within the period as prescribed in demand notice, following action shall be taken for recovery of the balance amount:</p> <p>a) from dues available in the form of Bills payable to defaulted Supplier/Vendor against the same contract.</p> <p>b) If it is not possible to recover the dues available from the same contract or dues are insufficient to meet the recoverable amount, balance amount shall be recovered from any money(s) payable to Supplier/Vendor under any contract with other Units of BHEL including recovery from security deposits or any other deposit available in the form of security instruments of any kind against Security deposit or EMD.</p> <p>vi) In-case recoveries are not possible with any of the above available options, Legal action shall be initiated for recovery against defaulted supplier/Vendor.</p> <p>vii) It is an agreed term of contract that this amount shall be a genuine pre-estimate of damages that BHEL would incur in completion of balance contractual obligation of the contract through any other agency and BHEL will not be required to furnish any other evidence to the Supplier/Vendor for the purpose of estimation of damages.</p> <p>viii) In addition to the above, imposition of liquidated damages, debarment, termination, de-scoping, short-closure, etc., shall be applied as per provisions of the contract.</p> <p>Note:</p> <p>1) The defaulting Supplier/Vendor shall not be eligible for participation in any of the future enquiries floated by BHEL to complete the balance work. The defaulting contractor shall mean and include:</p> <p>(a) In case defaulted Supplier/Vendor is the Sole Proprietorship Firm, any Sole Proprietorship Firm owned by same Sole Proprietor.</p> <p>(b) In case defaulted Supplier/Vendor is The Partnership Firm, any firm comprising of same partners/ some of the same partners ; or sole proprietorship firm owned by any partner(s) as a sole proprietor.</p>	
25.	Suspension of Business Dealings with Suppliers / Contractors:	<p>The offers of the bidders who are under suspension as also the offers of the bidders, who engage the services of the banned firms / principal / agents, shall be rejected. The list of banned firms is available on BHEL web site www.bhel.com.</p> <p>If any bidder / supplier / contractor during pre-tendering / tendering / post tendering / award / execution / post-execution stage indulges in any act, including but not limited to, mal-practices, cheating, bribery, fraud or and other misconduct or formation of cartel so as to influence the bidding process or influence the price or tampers the tendering process or acts or omits in any manner which tantamount to an offence punishable under any provision of the Indian Penal Code, 1860(Bhartiya Nyaya Samhita 2023) or any other law in force in India, or does anything which is actionable under the Guidelines for Suspension of Business dealings, action may be taken against such bidder / supplier / contractor as per extant guidelines of the company available on www.bhel.com and / or under applicable legal provisions. Guidelines for suspension of business dealings is available in the webpage: http://www.bhel.com/vender_registration/vender.php.</p>	
26.	Settlement of Dispute, CONCILIATION & ARBITRATION:	<p>Settlement of Dispute</p> <p>If any dispute or difference of any kind whatsoever shall arise between BHEL and the Supplier/Vendor, arising out of the contract for the performance of the work whether during the progress of contract termination, abandonment or breach of the contract, it shall in the first place referred to Designated Officer / IEM for amicable resolution by the parties. Designated Officer / IEM who within 60 days after being requested shall give written notice of his decision to the contractor. Save as hereinafter provided, such decision in respect of every matter so referred shall forthwith be given effect to by the Supplier/Vendor who shall proceed with the work with all due diligence, whether he or BHEL desires to resolve the dispute as hereinafter provided or not. If after the Designated Engineer has given written notice of this decision to the party and no intention to pursue the dispute has been communicated to him by the affected party within 30 days from the receipt of such notice, the said decision shall become final and binding on the parties. In the event the Supplier/Vendor being dissatisfied with any such decision or if amicable settlement cannot be reached then all such disputed issues shall be resolved through conciliation in terms of the BHEL Conciliation Scheme 2018 as per 'CONCILIATION' Clause.</p> <p>CONCILIATION:</p>	

		<p>Any dispute, difference or controversy of whatever nature howsoever arising under or out of or in relation to this Agreement (including its interpretation) between the Parties, and so notified in writing by either Party to the other Party (the "Dispute") shall, in the first instance, be attempted to be resolved amicably in accordance with the conciliation procedure as per BHEL Conciliation Scheme 2018. The proceedings of Conciliation shall broadly be governed by Part-III of the Arbitration and Conciliation Act 1996 or any statutory modification thereof and as provided in - "Procedure for conduct of conciliation proceedings" (as available in www.bhel.com).</p> <p>ARBITRATION: Except as provided elsewhere in this Contract, in case Parties are unable to reach amicable settlement (whether by Conciliation to be conducted as provided herein above or otherwise) in respect of any dispute or difference; arising out of the formation, breach, termination, validity or execution of the Contract; or, the respective rights and liabilities of the Parties; or, in relation to interpretation of any provision of the Contract; or, in any manner touching upon the Contract (hereinafter referred to as the 'Dispute'), then, either Party may, refer the disputes to Arbitral Institution and such dispute to be adjudicated by Sole Arbitrator appointed in accordance with the Rules of said Arbitral Institution.</p> <p>A party willing to commence arbitration proceeding shall invoke Arbitration Clause by giving notice to the other party in terms of section 21 of the Arbitration & Conciliation Act, 1996 (hereinafter referred to as the 'Notice') before referring the matter to arbitral institution. The Notice shall be addressed to the Head of the Region, Power Sector/ Unit, BHEL, executing the Contract and shall contain the particulars of all claims to be referred to arbitration with sufficient detail and shall also indicate the monetary amount of such claim including interest, if any.</p> <p>After expiry of 30 days from the date of receipt of aforesaid notice, the party invoking the Arbitration shall submit that dispute to the Arbitral Institutions (shall be identified by the contract issuing agency) and that dispute shall be adjudicated in accordance with their respective Arbitration Rules. The matter shall be adjudicated by a Sole Arbitrator who shall necessarily be a Retd Judge having considerable experience in commercial matters to be appointed/nominated by the respective institution. The cost/expenses pertaining to the said Arbitration shall also be governed in accordance with the Rules of the respective Arbitral Institution. The decision of the party invoking the Arbitration for reference of dispute to a specific Arbitral institution for adjudication of that dispute shall be final and binding on both the parties and shall not be subject to any change thereafter. The institution once selected at the time of invocation of dispute shall remain unchanged.</p> <p>The fee and expenses shall be borne by the parties as per the Arbitral Institutional rules.</p> <p>The Arbitration proceedings shall be in English language and the seat and venue of Arbitration shall be at the court(s) of Haridwar. Subject to the above, the provisions of Arbitration & Conciliation Act 1996 and any amendment thereof shall be applicable. All matters relating to this Contract and arising out of invocation of Arbitration clause are subject to the exclusive jurisdiction of the Court(s) situated at Haridwar , shall have exclusive jurisdiction.</p> <p>Notwithstanding any reference to the Designated Engineer or Conciliation or Arbitration herein, a. the parties shall continue to perform their respective obligations under the Contract unless they otherwise agree. Settlement of Dispute clause cannot be invoked by the Contractor, if the Contract has been mutually closed or 'No Demand Certificate' has been furnished by the Contractor or any Settlement Agreement has been signed between the Employer and the Contractor.</p> <p>It is agreed that Mechanism of resolution of disputes through arbitration shall be available only in the cases where the value of the dispute is less than Rs. 10 Crores. In case the disputed amount Claim, Counter claim including interest is Rs. 10 crores and above, the parties shall be within their rights to take recourse to remedies other than Arbitration, as may be available to them under the applicable laws after prior intimation to the other party. Subject to the aforesaid conditions, provisions of the Arbitration and Conciliation Act, 1996 and any statutory modifications or re-enactment thereof as amended from time to time, shall apply to the arbitration proceedings under this clause. In case, multiple arbitrations are invoked (whether sub-judice or arbitral award passed) by any party to under this contract, then the cumulative value of claims (including interest claimed or awarded) in all such arbitrations shall be taken in account while arriving at the total claim in dispute for the subject contract for the purpose of clause mentioned above. Disputes having cumulative value of less than 10 crores shall be resolved through arbitration and any additional dispute shall be adjudicated by the court of competent jurisdiction.</p>	
27.	Action against Bidders / vendor /	In order to protect the commercial interests of BHEL, BHEL shall take action against supplies / contractors by way of suspension of business dealings, who either fail to perform or are in default	

	supplier / contractor in case of default:	<p>without any reasonable cause, cause loss of business/ money/ reputation, indulge in malpractices, cheating, bribery, fraud or any other misconduct or formation of cartels so as to influence the bidding process or influence the price etc.</p> <p>Suspension of Business Dealings could be in the form of "Hold" or "Banning" a supplier/ contractor or a bidder and shall be as per "Guidelines for Suspension of Business Dealings with Suppliers/ Contractors" available at BHEL's website "https://www.bhel.com/guidelines-suspension-business-dealings-supplierscontractors"</p>													
28.	MICRO AND SMALL ENTERPRISES (MSE):	<p>Any Bidder falling under MSE category shall furnish the following details & submit documentary evidence/ Govt. Certificate etc. in support of the same along with their techno-commercial offer.</p> <table border="1" data-bbox="370 384 1357 520"> <thead> <tr> <th>Type under MSE</th> <th>SC/ST owned</th> <th>Women owned</th> <th>Others (excluding SC/ ST & Women Owned)</th> </tr> </thead> <tbody> <tr> <td>Micro</td> <td></td> <td></td> <td></td> </tr> <tr> <td>Small</td> <td></td> <td></td> <td></td> </tr> </tbody> </table> <p>Note: If the bidder does not furnish the above, offer shall be processed construing that the bidder is not falling under MSE category.</p> <p>a) MSE suppliers can avail the intended benefits in respect of the procurements related to the Goods and Services only (Definition of Goods and Services as enumerated by Govt. of India vide Office Memorandum F. No. 21(8)/2011-MA dtd. 09/11/2016 office of AS & DC, MSME) only if they submit along with the offer, attested copies of either Udyam Registration. Date to be reckoned for determining the deemed validity will be the last date of Technical Bid submission. Non-submission of supporting document in GeM portal will lead to consideration of their bids at par with other bidders. No benefits shall be applicable for this enquiry if the above required documents are not uploaded at the time of bid submission. Documents submitted by the bidder shall be verified by BHEL for rendering the applicable benefits.</p>	Type under MSE	SC/ST owned	Women owned	Others (excluding SC/ ST & Women Owned)	Micro				Small				
Type under MSE	SC/ST owned	Women owned	Others (excluding SC/ ST & Women Owned)												
Micro															
Small															
29.	JURISDICTION:	<p>This contract shall be governed by the Law for the time being in force in the Republic of India. Subject to clause(s) mentioned above of this contract, the Civil Court having original Civil Jurisdiction at Haridwar shall alone have exclusive jurisdiction in regard to all matters in respect of the Contract.</p>													
30.	Force Majeure	<p>"Force Majeure" shall mean circumstance which is: a) beyond control of either of the parties to contract, b) either of the parties could not reasonably have provided against the event before entering into the contract, c) having arisen, either of the parties could not reasonably have avoided or overcome, and d) is not substantially attributable to either of the parties And Prevents the performance of the contract, Such circumstances include but shall not be limited to: i) War, hostilities , invasion, act of foreign enemies. ii) Rebellion, terrorism, revolution, insurrection, military or usurped power, or civil war. iii) Riot, commotion or disorder by persons other than the contractor's personnel and other employees of the contractor and sub-contractors. iv) Strike or lockout not solely involving the contractor's personnel and other employees of the contractor and sub-contractors. v) Encountering munitions of war, explosive materials, ionizing radiation or contamination by radio-activity, except as may be attributable to the contractor's use of such munitions, explosives, radiation or radio- activity. vi) Natural catastrophes such as earthquake, tsunami, volcanic activity, hurricane or typhoon, flood, fire, cyclones etc. vii) Epidemic, pandemic etc.</p> <p>The following events are explicitly excluded from Force Majeure and are solely the responsibilities of the non-performing party: a) any strike, work-to-rule action, goslow or similar labour difficulty (b) late delivery of equipment or material (unless caused by Force Majeure event) and (c) economic hardship.</p> <p>If either party is prevented, hindered or delayed from or in performing any of its obligations under the Contract by an event of Force Majeure, then it shall notify the other in writing of the occurrence of such event and the circumstances thereof within 15 (fifteen) days after the occurrence of such event.</p> <p>The party who has given such notice shall be excused from the performance or punctual performance of its obligations under the Contract for so long as the relevant event of Force Majeure continues and to the extent that such party's performance is prevented, hindered or delayed. The Time for Completion shall be extended by a period of time equal to period of delay caused due to such Force Majeure event.</p> <p>Delay or non-performance by either party hereto caused by the occurrence of any event of Force Majeure shall not</p> <p>i) Constitute a default or breach of the Contract. ii) Give rise to any claim for damages or additional cost expense occasioned thereby, if and to the extent that such delay or non-performance is caused by the occurrence of an event of Force Majeure.</p> <p>BHEL at its discretion may consider short closure of contract after 1 year of imposition of Force Majeure in line with extant guidelines. In any case, Supplier/Vendor cannot consider deemed short-</p>													

		closure after 1 year of imposition of Force Majeure	
31.	Cartel Formation	The Bidder declares that they will not enter into any illegal or undisclosed agreement or understanding, whether formal or informal with other Bidder(s). This applies in particular to prices, specifications, certifications, subsidiary contracts, submission or non-submission of bids or any other actions to restrict competitiveness or to introduce cartelization in the bidding process. In case, the Bidder is found having indulged in above activities, suitable action shall be taken by BHEL as per extant policies/ guidelines.	
32.	Order of Precedence:	In the event of any ambiguity or conflict between the Tender Documents, the order of precedence shall be in the order below: <ul style="list-style-type: none"> a. Amendments/Clarifications/Corrigenda/Errata etc. issued in respect of the tender documents by BHEL. b. Buyer Added Bid Specific ATC c. GeM Bid Technical Conditions of Contract (TCC) d. GeM GTC 	
33.	Conflict of interest:	A bidder shall not have conflict of interest with other bidders. Such conflict of interest can lead to anti-competitive practices to the detriment of Procuring Entity's interests. The bidder found to have a conflict of interest shall be disqualified. A bidder may be considered to have a conflict of interest with one or more parties in this bidding process, if: <ul style="list-style-type: none"> a) they have controlling partner (s) in common; or b) they receive or have received any direct or indirect subsidy/financial stake from any of them; or c) they have the same legal representative/agent for purposes of this bid; or d) they have relationship with each other, directly or through common third parties, that puts them in a position to have access to information about or influence on the bid of another Bidder; or e) Bidder participates in more than one bid in this bidding process. Participation by a Bidder in more than one Bid will result in the disqualification of all bids in which the parties are involved. However, this does not limit the inclusion of the components/ sub-assembly/ Assemblies from. one bidding manufacturer in more than one bid; or f) In cases of agents quoting in offshore procurements, on behalf of their principal manufacturers, one agent cannot represent two manufacturers or quote on their behalf in a particular tender enquiry. One manufacturer can also authorize only one agent/dealer. There can be only one bid from the following: 1. The principal manufacturer directly or through one Indian agent on his behalf; and 2. Indian/foreign agent on behalf of only one principal or g) A Bidder or any of its affiliates participated as a consultant in the preparation of the design or technical specifications of the contract that is the subject of the Bid or h) In case of a holding company having more than one independently manufacturing units, or more than one unit having common business ownership/management, only one unit should quote. Similar restrictions would apply to closely related sister companies. Bidders must proactively declare such sister/ common business/ management units in same/ similar line of business. 	
34.	Guarantee clause	Kindly confirm that Guarantee for the supplied Pressure Gauge along with Spares against all manufacturing defects for a period of "24 months from the date of shipment or 12 months from date commissioning whichever is earlier" . In case of any failure or trouble reported from site, the supplier should depute their representative immediately to attend the problem and replace the defective component/part if required, without any additional cost to BHEL. Please note that offers with guarantee period lesser than above mentioned guarantee period may result in rejection of the offer.	
35.	Order Acceptance:	Ink signed order acceptance shall be furnished within 15 days of order placement. In case, order acceptance do not received within 15 days of order placement, PO deemed to be accepted by you.	
36.	Beneficiary of PO	Kindly confirm on whom the PO will be placed in the event of ordering.	
37.	IP Address	The bids received from same IP address shall be outrightly rejected and shall not be considered for further evaluation.	
38.	Dispatch documents	Following dispatch documents to be provided immediately after directly dispatch to BHEL Project site for billing purpose: <ul style="list-style-type: none"> • Guarantee/Warrantee Certificates • E- Invoice and commercial invoice • GeM invoice • Original consignee copies of GR/LR/RR (Material shall be dispatched on door delivery basis without consignee copy) • Packing list • Original GST compliance certificate • E-way bill • MRC/POD/Receipted LR/RR/GR copy (as per proof of delivery of material at BHEL Project site) 	

39.	Additional Conditions for Assessment	BHEL reserves the right to consider / Not-consider the offers based on the evaluation of documents submitted for the Pre-Qualification Criteria (PQR).	
		BHEL also reserves the right to have on-site assessment of the facilities at supplier's works during the bid evaluation.	
40.	Bidder Contact details	Please provide Contact details of your representative for techno-commercial clarifications: Mobile no. & Email id (minimum 2 person)	

SPECIAL NOTE FOR BIDDERS:

- a. In the event of our customer order covering this tender being cancelled /placed on hold /otherwise modified, BHEL would be constrained to accordingly cancel / hold / modify the tender at any stage of execution.
- b. BHEL may negotiate the L1 rate, if not meeting our budget / estimated cost. BHEL may re-float the tender opened, if L1 price is not acceptable to BHEL even after negotiation.
- c. Any change in applicable rates of Tax or any other statutory levies (Direct / Indirect) or any new introduction of any levy by means of statute and its corresponding liability for the deliveries beyond the agreed delivery date for reasons not attributable to BHEL will be to vendors account. BHEL will not reimburse the same and any subsequent claim in this respect will be summarily rejected.
- d. BHEL reserves its right to reject an offer due to unsatisfactory past performance by the respective Vendor in the execution of any contract to any BHEL project / Unit.
- e. The offers of the bidders who are under suspension and also the offers of the bidders, who engage the services of the banned firms /principal/agents, shall be rejected. The list of banned firms is available on BHEL web site www.bhel.com.
- f. Recovery / deduction as applicable as per Direct and Indirect taxes as notified by Govt. Of India from time to time will be made and information/certificate for such deduction/recoveries shall be provided by BHEL to the vendor.
- g. If the delivery of supply as detailed above gets delayed beyond the delivery period, the Supplier/Vendor shall request for a delivery extension and BHEL at its discretion may extend the Contract. However, if any 'Delivery extension' is granted to the Supplier/Vendor for completion of supply, due to backlog attributable to the Supplier/Vendor, then it shall be without prejudice to the rights of BHEL to impose LD for the delays attributable to the Supplier/Vendor.
- h. In case BHEL increase the quantity during currency of the contract in line with quantity variation clause of GeM bid, delivery extension on pro-rata basis shall be given for supply of these additional quantity.

Following documents are an integral part of this Tender Enquiry and endorsed copies of these documents (duly signed and stamped on each page, as a token of acceptance) are to be submitted/uploaded along with offer on GeM portal against this bid.

1. Please submit replica of Price schedule (without prices) showing "quoted" in place of price along with techno-commercial bid (Part-I).
2. Please submit signed & Stamped copy (each page) of duly filled of confirmation column of "Buyers Specific Additional Terms & Conditions (ATC)" and its clause wise supporting documents where required.
3. Please submit signed & stamped copy (each page) for qualifying PQR with proper filled information and related supporting documents as mentioned in PQR.
4. Please submit certificate of Minimum local content as specified in the Make In India Certificate of the tender



BHARAT HEAVY ELECTRICALS LIMITED

HEEP-HARIDWAR, UTTARAKHAND (249403)

General Instructions and Standard Terms & Conditions for bidding against Tender Enquiry (GISTC)

For Indian Bidders (Version Jun-2025, Rev: 08)

Annexure-3

Declaration for treatment of cases regarding conflict of interest

The bidder notes that a conflict of interest would said to have occurred in the tender process and execution of the resultant contract, in case of any of the following situations:

- a) If its personnel have a close personal, financial, or business relationship with any personnel of BHEL who are directly or indirectly related to the procurement or execution process of the contract, which can affect the decision of BHEL directly or indirectly;
- b) The bidder (or his allied firm) provided services for the need assessment/ procurement planning of the Tender process in which it is participating;
- c) Procurement of goods directly from the manufacturers/suppliers shall be preferred. However, if the OEM/Principal insists on engaging the services of an agent, such agent shall not be allowed to represent more than one manufacturer/ supplier in the same tender. Moreover, either the agent could bid on behalf of the manufacturer/ supplier or the manufacturer/ supplier could bid directly but not both. In case bids are received from both the manufacturer/ supplier and the agent, bid received from the agent shall be ignored. However, this shall not debar more than one Authorized distributor (with/ or without the OEM) from quoting equipment manufactured by an Original Equipment Manufacturer (OEM) in procurements under a Proprietary Article Certificate.
- d) A bidder participates in more than one bid in this tender process. Participation in any capacity by a Bidder (including the participation of a Bidder as a partner/ JV member or sub-contractor in another bid or vice-versa) in more than one bid shall result in the disqualification of all bids in which he is a party. However, this does not limit the participation of an entity as a sub-contractor in more than one bid if he is not bidding independently in his own name or as a member of a JV.

The Bidder declares that they have read and understood the above aspects, and the bidder confirms that such conflict of interest does not exist and undertakes that they will not enter into any illegal or undisclosed agreement or understanding, whether formal or informal with other Bidder(s), in this regard. This applies in particular to prices, specifications, certifications, subsidiary contracts, submission or non-submission of bids or any other actions to restrict competitiveness or to introduce cartelization in the bidding process.

In case, the Bidder is found having indulged in above activities, the same will be considered as a violation of the tender conditions, and suitable action shall be taken by BHEL as per extant policies/ guidelines.

(Signature of the authorized signatory of the bidder)

DECLARATION REGARDING MINIMUM LOCAL CONTENT IN LINE WITH
REVISED PUBLIC PROCUREMENT (PREFERENCE TO MAKE IN INDIA), ORDER 2017- REVISION
DATED 19TH JULY, 2024 AND SUBSEQUENT ORDER(S)

(To be typed and submitted in the Letter Head of the Entity/Firm providing certificate as applicable)

To,
(Write Name & Address of Officer of BHEL inviting the Tender)
Dear Sir,

Sub: Declaration reg. minimum local content in line with Public Procurement (Preference to Make in India), Order 2017-Revision, dated 19th July, 2024 and subsequent order(s).

Ref: 1) Tender Enquiry No:

2) All other pertinent issues till date

We hereby certify that the items offered by (specify the name of the organization here) has a local content of _____ % and this meets the local content requirement for '**Class-I local supplier**' / '**Class II local supplier**' ** as defined in Public Procurement (Preference to Make in India), Order 2017Revision dated 19.07.2024 issued by DPIIT and subsequent order(s).

The details of the location(s) at which the local value addition is made are as follows:

1. _____ 2. _____

3. _____ 4. _____

...

Thanking you,
Yours faithfully,

(Signature, Date & Seal of Authorized Signatory of the Bidder)

** - Strike out whichever is not applicable.

Note:

1. Bidders to note that above format, duly filled & signed by authorized signatory, shall be submitted along with the techno-commercial offer.
2. In case the bidder's quoted value is in excess of Rs. 10 crores, the authorized signatory for this declaration shall necessarily be the statutory auditor or cost auditor of the company (in the case of companies) or a practicing cost accountant or practicing chartered accountant (in respect of suppliers other than companies).
3. In the event of false declaration, actions as per the above order and as per BHEL Guidelines shall be initiated against the bidder.



BHARAT HEAVY ELECTRICALS LIMITED, HARIDWAR

Control & Instrumentation Engineering (CIE)

PRE-QUALIFICATION REQUIREMENT

Brief Description- Pressure Gauge for Steam Turbine Applications

DOCUMENT NO.

CIE/PG/PQR Rev 01

Dt: 15.10.25

Item Name / Description : Pressure Gauge

BHEL Material Codes : W97372603161, W97372603170, W97372603188, W97372603196, W97372603200, W97372603218, W97372603528, W97372603536, W97372603552, W97372603404, W97372603382, W97372603390, W97372603560, W97372603579, W97372603633, W97372603625, W97372603609, W97372603617, W97372603587, W97372603595, W97372603706, W97372603692, W97372603684, W97372603676, W97372603650, W97372603668, W97372603641, W97372603714, HW7310198077, HW7310198085, HW7310198093, HW7310198107, HW7310198115, HW7310198018, HW7310198026, HW7310198034, HW7310198042, HW7310198050, HW7310198069

SR. NO.	PRE-QUALIFICATION REQUIREMENTS	VENDOR RESPONSE
1.	Bidder should be manufacturer or Authorized Supplier of the Pressure Gauge or similar item suitable for Steam / Water and Oil Medium and supporting Documents / Authorization Letter to be provided in support of same.	
2.	Bidder / Authorized supplier should have supplied 5 Nos. Pressure Gauge in past 5 years from date of Enquiry. Unpriced PO copies / Experience List and supporting documents to be submitted in support of same.	
3.	BHEL intends to verify the capability of Bidder/ Authorized Supplier to arrange / conduct Type Tests. For this Bidder/Authorized supplier should have capability to conduct / arrange following Type Test from government accredited laboratory. A Certificate / Confirmation Letter confirming this, is to be submitted by the Bidder/ Authorized supplier- (a) Degree of Protection (b) Endurance Test (c) Temperature Influence Test (d) Shock Test	

Notes –

SR. NO.	NOTES	VENDOR RESPONSE
1	BHEL reserve the right to verify the information submitted by Bidder. In case the information is found to be false / incorrect, the offer shall be rejected. Bidder to confirm.	

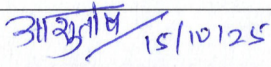
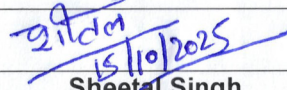
Worked by	Reviewed & Approved by
 15/10/25	 15/10/2025
A. Srivastava Manger	Sheetal Singh Sr. Manager

MANUFACTURER'S NAME AND ADDRESS		QUALITY PLAN					TO BE FILLED BY BHEL		TO BE FILLED BY BHEL			
BHEL	VENDOR'S NAME	ITEM	Pressure Gauge		QP NO.	QA/BE/QP/913						
				REV	04							
		DRG. NO.	AS PER PO									
		SPEC.	AS PER PO									
	REV	AS PER PO				Page 1 of 1						
SL. NO.	COMPONENT & OPERATIONS	CHARACTERISTICS	CLASS	TYPE OF CHECK	QUANTUM OF CHECK	REFERENCE DOCUMENT	ACCEPTANCE NORMS	FORMAT OF RECORDS	AGENCY			REMARKS
1	2	3	4	5	6	7	8	9	D	10	11	

1.00	In-coming Raw Material											
1.01	Material (Bourdon Tube, movement, Shank, Case)	Chemical & Mechanical	Major	Chemical composition	100% (Lot Wise)	Ordering Spec.	Ordering Spec./ BHEL Appd. Data Sheet	MTC	√	P	V	
2.00	In-Process Inspection											
2.01	Soundness of Assembly of Different Parts		Major	Visual & dimensional	100%	Manuf. Standard	Manuf. Standard	Internal record		P	-	
3.00	Final Inspection											
3.10	Type Test											
												NOTE-1
3.20	Routine Test											
3.21		Accuracy test/ Calibration	Critical	Accuracy test	100%	Ordering Spec./ BHEL Appd. Data Sheet	Ordering Spec./ BHEL Appd. Data Sheet	TC	√	P	W	
3.22		Over Load Test	Critical	Over load test	100%	Ordering Spec./ BHEL Appd. Data Sheet	Ordering Spec./ BHEL Appd. Data Sheet	TC	√	P	W	
3.23		Visual & Dimension	Critical	Visual & Dimensions	100%	Ordering Spec./ BHEL Appd. Data Sheet	Ordering Spec./ BHEL Appd. Data Sheet	TC	√	P	W	
4.00	Identification & Marking											
4.01	Identification/Marking/ Firmness of Tagging of each Instruments		Major	Visual	100%	Ordering Spec./ BHEL Appd. Data Sheet	Ordering Spec./ BHEL Appd. Data Sheet	Internal record	√	P	V	
4.02	Completeness of TCs /COC & Inspection report		Major	Visual & Physical	100%	Ordering Spec./ BHEL Appd. Data Sheet	Ordering Spec./ BHEL Appd. Data Sheet	Documents	√	P	V	
5.00	Soundness of Packing against transit Damage											
			Critical	Physical & Visual	100%	Ordering Spec./ Vendor's Std.	Ordering Spec./ BHEL Appd. Data Sheet	Internal record	√	P	-	

NOTE:

1. Type test clearance from BHEL engineering is to be verified by inspection engineer during inspection at vendor's works.
2. Manufacturer to maintain calibrated instruments having better accuracy than the item under the test. Inspection engineer shall check the same.
3. Witness by inspection agency to be random 10% of each material code (minimum 1 pieces per material code) from each lot whichever is higher. However vendor to carry out 100% tests internally and tests report shall be reviewed by inspection engineer during inspection at Vendor's works.

MANUFACTURER/SUBCONTRACTOR	LEGEND: ! RECORDS IDENTIFIED WITH 'TICK' SHALL BE ESSENTIALLY INCLUDED BY CONTRACTOR IN QA DOCUMENTATION. M: MANUFACTURER / SUBCONTRACTOR B: BHEL / NOM. INSPECTION AGENCY N: CUSTOMER INDICATE 'P' PERFORM 'W' WITNESS AND 'V' VERIFICATION ALL 'W' INDICATED IN COLUMN 'N' SHALL BE 'CHP' OF CUSTOMER	FOR CUSTOMER USE	APPROVED BY 	Digitally signed by Sachin Jain Date: 2020.06.15 10:48:28 +05'30'
----------------------------	--	------------------	---	---



उत्पाद मानक

HW7310198

ST- 48001

PRODUCT STANDARD
STEAM TURBINE ENGINEERING

पृष्ठ 1 का 7

Page 1 of 7

दिनांक एवं हस्ताक्षर
SIGN & DATE

SUPERSEDES
INVENTORY NO.

सामग्री सूची संख्या
को अधिकृत करता है।

COPYRIGHT AND CONFIDENTIAL

The information on this document is the property of Bharat Heavy Electrical Limited. It must not be used directly or indirectly in any way detrimental to the interest of the company.

स्वत्वाधिकार एवं गोपनीय

इस प्रलेख में दी गई सूचना भारत हेवी इलेक्ट्रिकल्स की सम्पत्ति है इसका प्रयोग एवं आख्या कर्म को किसी भी तरह प्रयोग, को कि कंपनी के हित में हानिकारक होना किया जाए।

PRESSURE GAUGE WITH S.S. BOURDON TUBE
AND SAFETY BLOW OUT DEVICE

0.0 SCOPE:

This specification covers the requirements of stainless steel bourdon tube type pressure gauges with bottom and back connections suitable for steam / water and oil service mediums in power plant applications.

1.0 DESIGNATION

(A) A pressure gauge of Form AR (direct mounting , bottom connection) thread size G 1/2", dial size 100 mm and range 0-10 kg/cm2, size no.114 (Ref Table 1 & 2) shall be designated as :

1.1 ON DRAWINGS :

- i) Drg. Col : ST-48001.114
- ii) Description Col : PRESSURE GAUGE AR100, 0-10 kg/cm2.
- iii) Material specn. : ST 448001

1.2 FOR PLACING PURCHASE INDENTS AND PURCHASE ORDERS :
PRESSURE GAUGE AR100, 0-10 kg/cm2, ST48001.114.

(B) A pressure gauge Form JR (panel mounting , back connection) thread size G 1/2" ,dial size 100 and range 0-10 kg/cm2 , size no.314 (Ref Table 1&2) shall be designated as :

1.3 ON DRAWINGS :

- i) Drg. Col : ST48001.314
- ii) Description Col : Pressure gauge JR100 , 0-10 kg/cm2

1.4 FOR PLACING PURCHASE INDENTS AND PURCHASE ORDERS:
Pressure Gauge JR100 , 0-10 kg/cm2 , ST-48001.314.

2.0 Compliance with national / International standard : IS : 3624(1987), IS: 13947(1993) /EN 837-1.

हस्ताक्षर एवं दिनांक SIGN & DATE	नाम NAME	दिनांक एवं हस्ताक्षर SIGN. & DATE
PSC member	अनुवादक TRANSLATED BY	
TSX	निर्माणकर्ता WORKED BY	J.S.BHANDARI
QAX	परीक्षणकर्ता CHECKED BY	VINOD KUMAR
सहमत विभाग AGREED DEPT.	पर्यवेक्षणकर्ता SUPERVISED BY	B.S. RANA
सामग्री सूची संख्या INVENTORY NO. P-5186	स्वीकृति : APPROVED : K.B. BATRA	
	ST 3.50	
Rev. No. 06	निर्माण : PREPARED	जारी : ISSUED
Date 07/07/25	TSX (HEEP) HWR	दिनांक : DATE 20.05.1988
WORKED BY L. KUMAR	SIGN & DATE Lalit Kumar	
CHECKED BY S.K. CHAURHAN	SIGN & DATE Ashutosh	
CHANGE ADVICE NO	TSX(STE)-25-87	

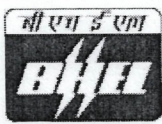
दिनांक एवं हस्ताक्षर SIGN & DATE		<h1 style="text-align: center;">उत्पाद मानक (हीप : हरिद्वार)</h1> <h2 style="text-align: center;">PRODUCT STANDARD (HEEP: HARIDWAR)</h2>	HW7310198 ST-48001	
SUPERSEDES INVENTORY NO.	NO.		पृष्ठ 7 का 2 Page 2 of 7	
सामग्री सूची संख्या को अधिकृत करता है	COPYRIGHT AND CONFIDENTIAL The information on this document is the property of Bharat Heavy Electrical Limited. It must not be used directly or indirectly in any way detrimental to the interest of the company	<p>3.0 TECHNICAL REQUIREMENTS: The gauges shall generally comply with IS:3624 or EN:837-1 with the following specific requirements:</p> <p>3.1 SENSING ELEMENT TYPE: BOURDON TUBE</p> <p>3.2 MATERIAL OF SENSING ELEMENT, SHANK & OTHER PARTS IN CONTACT WITH SERVICE MEDIUM: Stainless Steel AISI316 or equivalent.</p> <p>3.3 MOVEMENT PARTS MATERIAL: Stainless Steel or suitable material (for high life and without backlash).</p> <p>3.4 CASE: It shall be of stainless steel. The case shall be water and dust tight with degree of protection equivalent to IP65 as per IS:13947 or IS/IEC60529. The back wall of the case shall be provided with a blowout safety device to permit rapid and safe dissipation of internal pressure in the event of leakage or burst in the pressure responsive element.</p> <p>3.5 BEZEL RING: It shall be made of stainless-steel sheet.</p> <p>3.6 DIAL AND SCALE: Dial shall be made up of suitable metal with anti-corrosive finish. The dial shall be clearly printed with black markings on non-reflective white background. The scale shall be concentric (an angle of approx. 270 degree) and graduated in kg/cm² or bar as specified in the purchase order.</p>		
स्वत्वधिकार एवं गोपनीय	इस प्रदेय में दी गई सूचना भारत हेवी एलेक्ट्रिकल्स लिमिटेड की सम्पत्ति है सुरक्षा के उद्देश्य से किसी भी तरह प्रयोग जो कि कंपनी के हित में हानिकारक हो सके	<p>3.7 DIAL SIZE: For size AR (direct mounting bottom connection). Nominal Dial size should be considered as 150(+10) mm i.e. Dial size 150/160 mm both are acceptable as per EN 837-1.</p> <p>3.8 POINTER: The pointer shall be of suitable metal with black finish. Zero adjustment facility shall be provided.</p> <p>3.9 WINDOW: It shall be either of transparent acrylic plastic or safety laminated glass (toughened glass).</p> <p>3.10 MOUNTING: Direct for From AR (Ref. Fig 1) and flush for From JR (Ref. Fig 2).</p>		
दिनांक एवं हस्ताक्षर SIGN & DATE	Sandeep 14/11/25	<p>3.11 ACCURACY: Equal or better than $\pm 1\%$ of full-scale deflection.</p> <p>3.12 AMBIENT CONDITION: Ambient temperature up to 60 degree centigrade and relative humidity 95%.</p>		
सामग्री सूची संख्या INVENTORY NO.	REV. NO. 06	SUPERSEEDS	निर्माणकर्ता WORKED BY BRIJ LAL RAM	श्रीलालराम 07/07/25
सामग्री सूची संख्या INVENTORY NO.	REV. NO. 06		जांचकर्ता CHECKED BY ASHUTOSH SRIVASTAVA	अशुतोष 07/07/25

निम्नलिखित हस्ताक्षर SIGN & DATE		उत्पाद मानक (हीप : हरिद्वार) PRODUCT STANDARD (HEEP: HARIDWAR)		HW7310198 ST-48001 पृष्ठ 7 का 3 Page 3 of 7	
सामग्री सूची संख्या को अतिरिक्तित्व करना है NO	<p>3.13 OVER PRESSURE: As per IS: 3624 or EN: 837-1</p> <p>4.0 IDENTIFICATION TAG: In addition to the instrument name plate one separate stainless-steel blank tag (20 x 60 mm) shall be fastened with the gauge.</p> <p>5.0 TEST CERTIFICATE: Three copies of following test certificates shall be furnished</p> <p>5.1 The gauge shall be tested for the following tests and degree of protection as per IS :3624 / EN: 837-1 certificates produced.</p> <p>i) Routine tests: As per IS :3624 or EN: 837-1 a) Accuracy Test (class 1B)/ Calibration. b) Overload Test</p> <p>ii) Type Tests • a) Endurance Test: As per IS :3624 or EN: 837-1 b) Enclosure Protection Class • IP65 as per IS :13947(1993) c) Temp. Influence Test: As per IS :3624 or EN: 837-1 d) Shock test As per IS :3624 or EN: 837-1</p> <p>5.2 Material certificate for element, movement, shank, case,</p> <p>6.0 GUARANTEE CERTIFICATE: A guarantee certificate for trouble free performance for 24 months from the date of shipment or 12 months from the date of commissioning whichever is earlier shall be furnished</p> <p>7.0 DOCUMENT: Two copies of descriptive catalogs indicating sectional, dimensional and mounting details with the help of sketches, full technical particulars including material specification of all components and data against the technical requirement of this specification shall be furnished by the bidder along with the offer. Three copies of the same shall be furnished after placement of purchase order.</p> <p>8.0 PACKING: Each gauge shall be sealed individually in a bubbled polythene sheet and packed in a thermocole box, the process connection shall additionally be protected by suitable cap. Such boxes in turn shall be packed in a carton or case with adequate cushioning materials in order to be capable of withstanding normal transmit risk without damage. If required the package shall be seaworthy.</p>				
COPYRIGHT AND CONFIDENTIAL The information on this document is the property of Bharat Heavy Electrical Limited. It must not be used directly or indirectly in any way detrimental to the interest of the company					
स्वत्वधिकार एवं गोपनीय इस दस्तावेज में की गई सूचना भारत हीवी एलेक्ट्रिकल लिमिटेड की संपत्ति है प्रकृत सूचना को बिना अनुमति के किसी भी तरह प्रयोग या कि कंपनी के हित में हस्तिकारक हो न किया जाय।					
निम्नलिखित हस्ताक्षर SIGN & DATE <i>Sandep 14/7/25</i>					
सामग्री सूची संख्या INVENTORY NO. P-5186	REV. NO. 06	SUPERSEEDS	निर्माणकर्ता WORKED BY BRIJ LAL RAM	07/07/25	07/07/25
			जांचकर्ता CHECKED BY ASHUTOSH SRIVASTAVA	07/07/25	07/07/25

दिनांक एवं हस्ताक्षर SIGN & DATE		उत्पाद मानक PRODUCT STANDARD STEAM TURBINE ENGINEERING	HW 7310198 ST- 48001
			पृष्ठ 4 का 7 Page 4 of 7

सामग्री सूची संख्या
को अधिकारिणित करना है ।
SUPERSEDES
INVENTORY NO.

9.0 MARKING :

The following details shall be marked on the packing case :

a) Manufacturer's name or trade mark.

b) BHEL order number .

10.0 SPARE :

The suppliers shall enclose a list of spare parts required for five years normal operation and quote for the same separately.

11.0 QUALITY PLAN :

Detail Quality plan for the tests and checks to be carried out during material induction, manufacturing and final stages shall be submitted in BHEL's format alongwith in house standard procedures/norms for BHEL's approval .

12.0 CROSS REFERED : IS: 3624(1987), IS: 13947(1993) and EN : 837-1

स्वत्वाधिकार एवं गोपनीय
इस दस्तावेज में दी गई सूचना भारत के ही इस्तेमाल के लिए है। इसका प्रयोग एवं अपर्याप्त रूप से किसी भी तरह प्रयोग, जो कि कम्पनी के हित में हानिकारक हो न किया जाए ।
The information on this documents is the property of Bharat Heavy Electrical Limited. It must not be used directly or indirectly in any way detrimental to the interest of the company.
COPYRIGHT AND CONFIDENTIAL

हस्ताक्षर एवं दिनांक
SIGN & DATE

सामग्री सूची संख्या
INVENTORY NO
P-5786

REV NO.
06

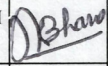
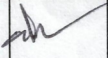
निर्माणकर्ता Worked by	J.S BHANDARI		18/6/12
जांचकर्ता Checked by	V.KUMAR		19/6/12

सामग्री सूची संख्या को अधिकृतित करना है	SUPERSEDES INVENTORY NO.	<u>TABLE -1</u> MEASURING RANGE, DIMENSION AND SIZE NUMBER (KG/CM2):	
--	--------------------------------	---	--

ALL dimensions are in mm

Measuring Range	Form Dial size Nom.	AR		JR	
		100	150 (Refer clause 3.7 also)	100	150
Kg/cm ²	d1	-	-	5.2	5.8
	PCD d2	-	-	116	178
	OD d3	-	-	134±2	196±2
Panel cut out		-	-	102	165

Size Number				
-1 to 0	101	201	301	401
-1 to 0.6	102	202	302	402
-1 to 1.5	103	203	303	403
-1 to 3	104	204	304	404
-1 to 5	105	205	305	405
-1 to 9	106	206	306	406
-1 to 15	107	207	307	407
0 to 0.6	108	208	308	408
0 to 1	109	209	309	409
0 to 1.6	110	210	310	410
0 to 2.5	111	211	311	411
0 to 4	112	212	312	412
0 to 6	113	213	313	413
0 to 10	114	214	314	414
0 to 16	115	215	315	415
0 to 25	116	216	316	416
0 to 40	117	217	317	417
0 to 60	118	218	318	418
0 to 100	119	219	319	419
0 to 160	120	220	320	420
0 to 250	121	221	321	421
0 to 400	122	222	322	422
0 to 600	123	223	323	423
0 to 1000	124	224	324	424

COPYRIGHT AND CONFIDENTIAL
The information on this document is the property of Bharat Heavy Electrical Limited. It must not be used directly or indirectly in any way detrimental to the interest of the company

स्वत्वाधिकार एवं गोपनीय
इस प्रलेख में दी गई सूचना भारत हीवी एलेक्ट्रिकल लिमिटेड की सम्पत्ति है। इसका प्रत्यक्ष एवं अप्रत्यक्ष रूप से किसी भी तरह प्रयोग, जो कि कंपनी के हित में हानिकारक

दिनांक एवं हस्ताक्षर
SIGN & DATE
Sandeep 14/7/25

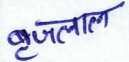
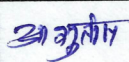
सामग्री सूची संख्या INVENTORY NO.	REV. NO.	SUPERSEEDS	निर्माणकर्ता WORKED BY	BRIJ LAL RAM		07/07/25
P-5186	06		जांचकर्ता CHECKED BY	ASHUTOSH SRIVASTAVA		07/07/25



उत्पाद मानक (हीप : हरिद्वार)

HW7310198

ST-48001

PRODUCT STANDARD (HEEP: HARIDWAR)

पृष्ठ 7 का 6
Page 6 of 7दिनांक एवं हस्ताक्षर
SIGN & DATESUPERSEDES
INVENTORY
NO.सामग्री सूची संख्या को
अधिकृतित करता है

COPYRIGHT AND CONFIDENTIAL

The information on this document is the property of Bharat Heavy Electrical Limited. It must not be used directly or indirectly in any way detrimental to the interest of the company

स्वत्वाधिकार एवं गोपनीय

इस संकेत में दी गई सूचना भारत हेवी एलेक्ट्रिकल्स लिमिटेड की सम्पत्ति है, इसका प्रयोग एवं अप्रत्यक्ष रूप से किसी भी तरह प्रयोग, जो कि कंपनी के हित में हानिकारक

दिनांक एवं हस्ताक्षर
SIGN & DATE

Sandeep 14/7/15

सामग्री सूची संख्या
INVENTORY NO.

P-5186

REV. NO.

06

SUPERSEEDS

निर्माणकर्ता
WORKED BY

BRIJ LAL RAM

07/07/25

जांचकर्ता
CHECKED BYASHUTOSH
SRIVASTAVA

07/07/25

TABLE -2

MEASURING RANGE, DIMENSION AND SIZE NUMBER (BAR)

ALL dimensions are in mm

Measuring Range	Form Dial size Nom.	AR		JR	
		100	150 (Refer clause 3.7 also)	100	150
Bars	d1	-	-	5.2	5.8
	PCD d2	-	-	116	178
	OD d3	-	-	134±2	196±2
Panel cut out		-	-	102	165

Size Number

-1 to 0	501	601	701	801
-1 to 0.6	502	602	702	802
-1 to 1.5	503	603	703	803
-1 to 3	504	604	704	804
-1 to 5	505	605	705	805
-1 to 9	506	606	706	806
-1 to 15	507	607	707	807
0 to 0.6	508	608	708	808
0 to 1	509	609	709	809
0 to 1.6	510	610	710	810
0 to 2.5	511	611	711	811
0 to 4	512	612	712	812
0 to 6	513	613	713	813
0 to 10	514	614	714	814
0 to 16	515	615	715	815
0 to 25	516	616	716	816
0 to 40	517	617	717	817
0 to 60	518	618	718	818
0 to 100	519	619	719	819
0 to 160	520	620	720	820
0 to 250	521	621	721	821
0 to 400	522	622	722	822
0 to 600	523	623	723	823
0 to 1000	524	624	724	824

उत्पाद मानक

HW 7310198

PRODUCT STANDARD
STEAM TURBINE ENGINEERING

ST- 48001

पृष्ठ 7 का 7

Page 7 of 7



दिनांक एवं हस्ताक्षर
SIGN & DATE

सामग्री सूची संख्या
को अधिकतम करता है ।
SUPERSEDES
INVENTORY NO.

COPYRIGHT AND CONFIDENTIAL

The information on this document is the property of Bharat Heavy Electricals Limited. It must not be used directly or indirectly in any way detrimental to the interest of the company.

स्वत्वाधिकार एवं गोपनीय

इस प्रलेख में दी गई सूचना भारत हेवी इलेक्ट्रिकल्स की सम्पत्ति है। इसका प्रयोग अन्यथा रूप से किसी भी तरह प्रयोग, जो कि सीधे या अप्रत्यक्ष रूप से इसका हित नष्ट करे, न किया जाए।

हस्ताक्षर एवं दिनांक
SIGN & DATE

सामग्री सूची संख्या
INVENTORY NO.

REV NO.

06

निर्माणकर्ता

J.S BHANDARI

Worked by

V.KUMAR

जांचकता

Checked by

FORM AR
(WITHOUT MOUNTING FLANGE)

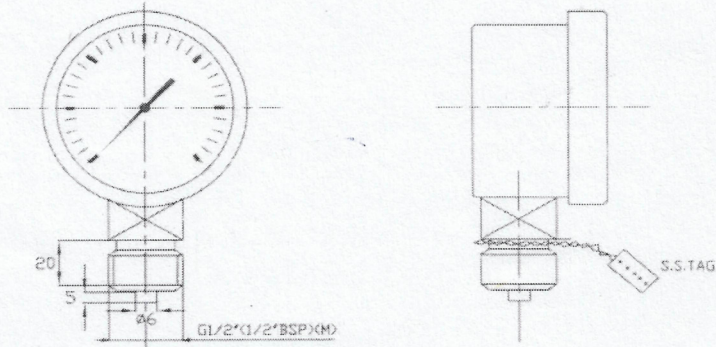

FIG. 1

FORM JR
(WITH MOUNTING FLANGE)

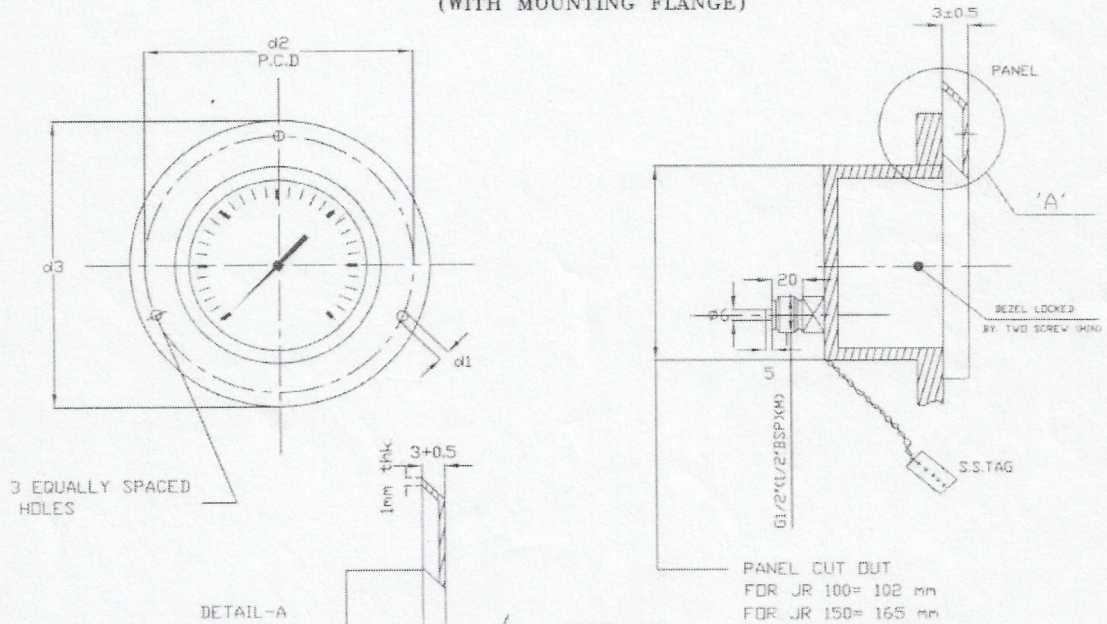

FIG. 2

J.S Bhandari 12/6/12
V.Kumar 13/6/12

दिनांक एवं हस्ताक्षर SIGN & DATE		उत्पाद मानक (हीप : हरिद्वार)	ST33002
		PRODUCT STANDARD (HEEP: HARIDWAR)	पृष्ठ 10 का 1 Page 1 of 10

सुपरसेडस INVENTORY NO	<p style="text-align: right;"><u>BASED ON OWN EXPERIENCE</u></p> <p style="text-align: center;"><u>GENERAL AND SEAWORTHY PACKING INSTRUCTIONS FOR TURBINE INSTRUMENTATION EQUIPMENT & ACCESSORIES</u></p>

This instruction covers the packing instruction for the safe dispatch and delivery of turbine instrumentation equipment like Electronic modules/ components, Indicator, Recorders, Transmitter, gauges, switches and other allied items, control cabinets & desks, Fitting, mounting accessories, impulse pipe lines and other related equipment and accessories.

2.0 INTRODUCTION:

The Turbine instrumentation equipment, components, cabinets and other accessories are of precision storage and special packaging is necessary to ensure safe transit and delivery of these items at the sites. Packaging should be done to protect these sophisticated and precision items against damage by means of shocks and vibration during handling and transportation, moisture, dust and other adverse climatic and environmental conditions. This specification is arranged in section as below:

- SECTION A: General packaging instructions common for all categories of items.
- SECTION B: Electronic modules, instruments & allied items.
- SECTION C: Starter panels.
- SECTION D: Fitting, mounting accessories and
- SECTION E: Impulse pipes.

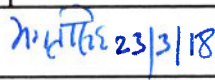



दिनांक एवं हस्ताक्षर SIGN & DATE		नाम NAME	दिनांक एवं हस्ताक्षर SIGNATURE & DATE
		अनुवादक TRANSLATED BY	
STE	D.K.RAY	निर्माणकर्ता WORKED BY	BRIJ LAL RAM
QAX	S. Chandra	जांचकर्ता CHECKED BY	LAXMI KANT MISHRA
TSX	LALIT KUMAR	पर्यवेक्षणकर्ता SUPERVISED BY	VINOD KUMAR
महामन विभाग AGREED DEPTT.	नाम NAME	दिनांक एवं हस्ताक्षर DATE & SIGNATURE	
REAFFIRM YEAR-2025	स्वीकृत APPROVED : B.S.RANA		Gr. NO. ST6.18
REV.NO.	02	निर्माण PREPARED : C.I.E	आरी ISSUED : TSX
Dt.	24/02/2025	दिनांक DATE : 16.03.81	
CHANGE ADVICE NO.	TSX(CIE)-25-47		





स्वातंत्र्यकार एवं गोपनीय
 इस प्रलेख में दी गई सूचना भारत के ही संप्रति के अधिकार प्रकृत
 एवं अन्तर्गत रूप में किसी भी तरह प्रयोग को कि कम्पनी के हित में हानिकारक हो न
 किताब जाय.

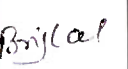





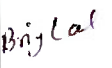

COPYRIGHT AND CONFIDENTIAL
 The information on this documents is the property of Bharat Heavy Electrical Limited. It must not be used directly or indirectly in any way detrimental to the interest of the company



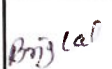

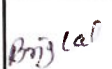
मासकी सूची मन्दा को
 अप्रतिनिध करण है

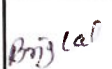
दिनांक एवं हस्ताक्षर
 SIGN & DATE

रिकॉर्ड नंबर SIGN & DATE		उत्पाद मानक (हीप : हरिद्वार) PRODUCT STANDARD (HEEP: HARIDWAR)		ST33002 पृष्ठ 10 का 2 Page 2 of 10	
SUPERSEDES INVENTORY	3.0 <u>PACKAGING INSTRUCTIONS :</u>				
भारतीय नौकाओं अधिकारित लोगो #	3.1 (A) <u>GENERAL :</u>	(i) The packaging should be done in a clean, dust free packing area/room. (ii) Wherever possible, the original packing materials like thermocol box/ chips, packing paper, board, cotton waste, rubberized coir, wood wool etc. should be used for packaging of these equipments etc. (iii) All the items should be thoroughly checked for any possible mechanical damage/ distortion/ dents and rust/ corrosion etc. Appropriate rectification measures should be taken to remove such defects and if required engineering division should be consulted. (iv) While packaging, all the items should be temporarily stored on raised wooden platform covered with clean parchment paper. (v) The repacking of all the bought out items must be done in the original way as they were received from the manufacturers/ suppliers. It must be ensured that the polythene bags are properly sealed, air tight and sufficient cushioning with rubberized coir or wood wool has been provided to various items and containers/ boxes. (vi) The packing box should be made water proof by putting a continuous barrier of water- proof bitumen paper/craft paper over the internal surfaces of the box to make it sufficiently impervious to water, and small silica gel bags suitably placed inside the packages. This can be done by using tar felt on the top of all the boxes. It should project by 50mm on all the sides and projected part should be nailed and overlap of the tar felt should be avoided. (vii) The packaging should be done in such a way that the individual instruments/ containers/ boxes do not have relative movement inside the packing box during handling and transportation. Sufficient stiffness should be provided on the packing boxes to withstand mechanical shocks/ vibrations and other transit hazards. (viii) Wherever necessary, threaded/ machined portion should be coated with grease and wrapped with wax paper and tied with thread. Alternatively, threaded part may be wrapped with corrugated paper.			
COPYRIGHT AND CONFIDENTIAL The information on this documents is the property of Bharat Heavy Electrical Limited. It must not be used directly or indirectly in any way detrimental to the interest of the company					
स्वत्वाधिकार एवं गोपनीय इस प्रतीक में की गई सूचना भारत हेवी इलेक्ट्रिकल्स लिमिटेड की सम्पत्ति है इसका प्रयोग पाठ्य अथवा अन्य किसी भी तरह प्रयोग और कि सम्पत्ति के हित में इस्तेमाल नहीं किया जाय।					
रिकॉर्ड नंबर SIGN & DATE 	REV. NO. 02		निर्माणकर्ता WORKED BY	BRIJ LAL RAM	 23/03/18
भारतीय नौकाओं INVENTORY NO. P-5284			जांचकर्ता CHECKED BY	LAXMIKANT MISHRA	 23/03/18

दिनांक एवं प्रमाणित SIGN & DATE		उत्पाद मानक (हीप : हरिद्वार) PRODUCT STANDARD (HEEP: HARIDWAR)		ST33002 पृष्ठ 10 का 3 Page 3 of 10	
SUPERSEDES INVENTORY श्रमणी मूली संख्या में अभिलेखित करना है	3.2 (B) ELECTRONIC MODULES INSTRUMENTS AND ALLIED ITEMS: <ul style="list-style-type: none"> (i) All the Electronic modules/instruments and accessories should bear respective tag numbers as indicated in the shipping list. (ii) Individual instruments like indicators, recorders, transmitters, gauges, switches, detectors and electronic modules/ components should be sealed air tight in polythene bags which should contain silica gel in small bags of cotton cloth. Also volatile corrosion inhibitor (VCI) powder on table can be put in the bags/boxes containing the instruments. (iii) After sealing in polythene bags these items should be packed in small sized boxes, preferably original ones, with sufficient thermocol chip/ molded thermocol box/ card board box as the case may be. These boxes should be packed with sticking cello tapes and cotton tapes. (iv) The outside of these smaller boxes should carry dispatch unit number, packing box number and the tag number of the instrument/ equipment as shown in the shipping list. (v) Number of such small sized boxes should be kept in bigger sized box/carbon and these boxes/cartons should be in turn securely placed in the packing box in such a way that no damaged occurs because of handling, shifting, lifting or transportation. (vi) Thermocouple and Resistance thermometer shall be packed in suitable sized wooden box with appropriate & sufficient cushioning materials. 				
COPYRIGHT AND CONFIDENTIAL The information on this documents is the property of Bharat Heavy Electrical Limited It must not be used directly or indirectly in any way detrimental to the interest of the company	3.3 (C) CABINETS & STARTER PANELS : <ul style="list-style-type: none"> (i) The cabinet or starter panels should be clamped securely and firmly to the base plate of packing box with suitable nuts & bolts. (ii) The cabinets or starter panels shall be sealed airtight with polythene bags and a cotton bag containing silica gel shall be place inside the cabinets. As the cabinets/ starter panels etc. contain small mechanical contacts so VCI paper can be wrapped all around and fixed with tape. (iii) Sufficient stiffness/braces with padded cushions should be provided to ensure rigid packing. 				
	स्वाधिकार एवं गोपनीय इस प्रबंध में की गई सेवा का श्रेय एवं अधिकार बिना किसी भी शर्त के केवल भारत भारती लिमिटेड को ही प्राप्त है। इसका प्रयोग अन्य किसी भी उद्देश्य के लिए बिना भारत भारती लिमिटेड की लिखित अनुमति के किया जा सकता है।				
दिनांक एवं प्रमाणित SIGN & DATE 					
श्रमणी मूली संख्या INVENTORY NO. P-5284	REV. NO. 02		निर्माणकर्ता WORKED BY BRIJ LAL RAM		28/03/18
			जांचकर्ता CHECKED BY LAXMIKANT MISHRA		28/03/18

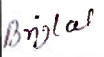
दिनांक एवं तिथि SIGN & DATE		<p style="text-align: center;">उत्पाद मानक (हीप : हरिद्वार)</p> <p style="text-align: center;">PRODUCT STANDARD (HEEP: HARIDWAR)</p>	<p style="text-align: center;">ST33002</p> <p style="text-align: center;">पृष्ठ 10 का 4 Page 4 of 10</p>								
SUPERSEDES INVENTORY सामग्री सूची नकल को अतिरिक्त करना है	<p>3.4 (D) FITTINGS & MOUNTING ACCESSORIES ETC. :</p> <p>(i) This category includes items like instrument valves, nipples, brackets, fasteners etc.</p> <p>(ii) Apply appropriate coating of grease on the threaded and machine portion and wrap the individual item with wax paper and tie with thread.</p>										
COPYRIGHT AND CONFIDENTIAL The information on this documents is the property of Bharat Heavy Electrical Limited. It must not be used directly or indirectly in any way detrimental to the interest of the company	<p>3.5 (E) IMPULSE PIPE LINES :</p> <p>(i) Impulse pipe lines are to be closed at both the ends by rubber plugs/ Neoprene grommets to prevent the clogging of pipelines by foreign materials/ dust, wood powder etc.</p> <p>(ii) While packing these pipelines care should be taken that no heavy material is put on top of them. This is necessary to ensure protection against mechanical damage.</p> <p>(iii) All the impulse pipe lines in a packing box should be tied with steel wires in small groups of 10-15 pipe lines</p> <p>(iv) Due care should be taken so that loose item such as above do not collide with each other causing damage to thread /machined part.</p>										
स्वत्वाधिकार एवं गोपनीय इस प्रलेख में की गई सूचना भारत हेवी इलेक्ट्रिकल्स लिमिटेड की सम्पत्ति है. इसका प्रयोग एवं प्रसारण अन्य से किसी भी रूप में बिना इस कंपनी के लिखित अनुमति के किया जाना नहीं है.	<p>4.0 SEA-WORTHY PACKING INSTRUCTIONS FOR EXPORT PROJECTS AND SEA COASTAL PROJECTS:</p> <p>4.1 GENERAL The standard covers guide lines for making Sea- worthy standard packing boxes to be used for transportation for export orders. Vendors shall be responsible for packing and shall meet the minimum requirements specified herein.</p> <p>4.2 SCOPE IN ADDITION TO CLAUSE NO. 1.0 AS ABOVE The procedure specifies minimum guidelines to be complied with for packing of electrical and electronic Components /Assemblies/Equipments. This specification shall be suitable for different handling operations and the adverse conditions during transportation and during indoor/outdoor storage for period of minimum two years.</p>										
दिनांक एवं तिथि SIGN & DATE 	<p>4.3 WOOD SPECIFICATION FOR PACKING The wood used for packing shall conform to specification ISPM NO. 15. (International Standards for Phytosanitary Measures).</p>										
सामग्री सूची संख्या INVENTORY NO P-5284	REV. NO. 02		<table border="1"> <tr> <td>निर्माणकर्ता WORKED BY</td> <td>BRIJ LAL RAM</td> <td></td> <td>28/03/18</td> </tr> <tr> <td>जांचकर्ता CHECKED BY</td> <td>LAXMIKANT MISHRA</td> <td></td> <td>28/03/18</td> </tr> </table>	निर्माणकर्ता WORKED BY	BRIJ LAL RAM		28/03/18	जांचकर्ता CHECKED BY	LAXMIKANT MISHRA		28/03/18
निर्माणकर्ता WORKED BY	BRIJ LAL RAM		28/03/18								
जांचकर्ता CHECKED BY	LAXMIKANT MISHRA		28/03/18								

निम्न सूची संख्या में SIGN & DATE		उत्पाद मानक (हीप : हरिद्वार) PRODUCT STANDARD (HEEP: HARIDWAR)		ST33002 पृष्ठ 10 का 5 Page 5 of 10	
सुपेर्सेडिड INVENTORY	<p>4.4 REQUIREMENTS FOR PACKING CASE:</p> <p>4.4.1 All equipment and materials shall be suitably coated wrapped, or covered and boxed or crated for export shipment so as to prevent damage during handling and storage at the Site. Cardboard containers (if any) shall be enclosed in a solid wooden container to avoid damage during transit.</p> <p>4.4.2 Equipment and process materials shall be packed and semi knocked down, to the extent possible, to facilitate handling and storage and to protect bearings and other machine surfaces from oxidation. Each container box, crate or bundle shall be reinforced with steel strapping, in such a manner that breaking of one strap will not cause complete failure of the packaging. The packing shall be of best standard to withstand rough handling and to provide suitable protection from tropical weather while in transit and while awaiting erection at the site.</p> <p>4.4.3 Waterproof paper and felt linings shall overlap at seams at least 15mm and the seams shall be secured together.</p> <p>4.4.4 Equipment and materials in wooden cases or crates shall be properly cushioned to withstand the abuse of handling, transportation and storage. Packing shall include preservatives suitable for tropical conditions. All machine surfaces and bearings shall be coated with oxidation preventative compounds. All parts subject to damage when in contact with water shall be coated with suitable grease and wrapped in heavy asphalt or tar impregnated paper.</p> <p>4.4.5 Fumigation of boxes including plywood/spacers shall be carried out as per ISPM 15 to make it pest free. All wood packing in each consignment shall be free from bark and all visible signs and fungal attack at the time of shipment.</p> <p>4.4.6 Components sub-assemblies and assemblies sensitive to climatic conditions shall be packed seal tight. All the openings of the sensitive components, sub-assemblies and assemblies shall be blanketed to prevent the ingress of dust and moisture. The components sub-assemblies and assemblies shall be completely covered with 2 layers of polyethylene sheet. Polyethylene sheet to be used shall be UV stabilized. All sharp corners and edges are to be protected by rubber mats to prevent damage the polyethylene sheet. Top surface of the case shall be free from dents to prevent rain water pockets.</p>				
COPYRIGHT AND CONFIDENTIAL The information on this documents is the property of Bharat Heavy Electrical Limited. It must not be used directly or indirectly in any way detrimental to the interest of the company					
स्वत्वाधिकार एवं गोपनीय इस प्रस्ताव में दी गई सूचना भारत भारती लिमिटेड की संपत्ति है। इसका प्रयोग अन्य किसी भी उद्देश्य के लिए या इसका प्रसारण अन्य किसी भी उद्देश्य के लिए न किया जाय।					
निम्न सूची संख्या में SIGN & DATE 					
सामग्री सूची संख्या INVENTORY NO. P-5286	REV. NO. 02		निर्माणकर्ता WORKED BY BRIJ LAL RAM		28/03/18
			जांचकर्ता CHECKED BY LAXMIKANT MISHRA		28/03/18

शारीरी मूल्य मंडल को प्रतिबिम्बित करता है
 SUPERSEDES INVENTORY

4.4.7 The four sides shall be lined, from inside with multi-layered polyethylene sheet of at least 120 GSM and tacked at suitable places.

Whenever specified in addition to the polyethylene sheet the top cover will have a layer of bitumen felt over the cover. This should project about 100 - 250 mm on all sides shall be provided between frame and planks of the end and side shook as shown in Fig. (For reference only.)

COPYRIGHT AND CONFIDENTIAL
 The information on this documents is the property of Bharat Heavy Electrical Limited. It must not be used directly or indirectly in any way detrimental to the interest of the company

स्वत्वाधिकार एवं गोपनीय
 इस प्रलेख में की गई सूचना भारत की प्रौद्योगिकी विभिन्नता की सम्पत्ति है इसका प्रयोग एवं प्रसारण अन्य में किसी की तसट प्रयोग को बिना कम्पनी के लिख में इतिकारक हो न किया जाय।

चिह्न एवं तारीख
SIGN & DATE
[Signature] 27/03/18

शारीरी मूल्य मंडल
INVENTORY NO.
 P-5284

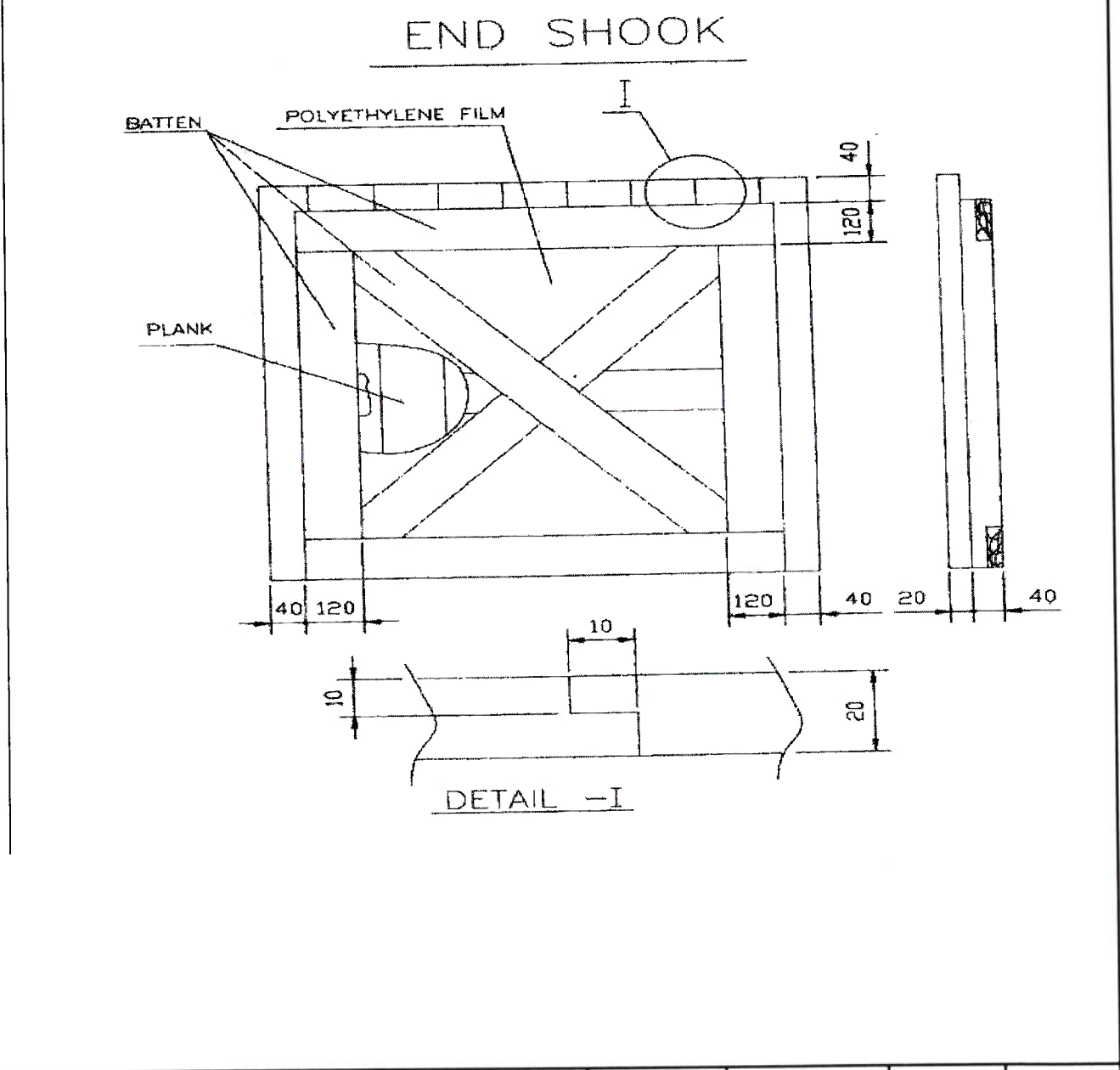

REV. NO. 02		निर्माणकर्ता WORKED BY	BRIJ LAL RAM	<i>Brij Lal</i>	23/03/18
		जांचकर्ता CHECKED BY	LAXMIKANT MISHRA	<i>[Signature]</i>	23/03/18



उत्पाद मानक (हीप : हरिद्वार)

ST33002

PRODUCT STANDARD (HEEP: HARIDWAR)

पृष्ठ 10 का 7
Page 7 of 10

निर्माण प्रमाण
SIGN & DATE

सुपेर्सेडेड
INVENTORY

कॉपीराइट एंड कॉन्फिडेंटियल
The information on this document is the property of Bharat Heavy Electrical Limited. It must not be used directly or indirectly in any way detrimental to the interest of the company

स्वायत्तिका एंड गोपनीय
इस प्रलेख में दी गई सूचना भारत हेवी इलेक्ट्रिकल्स लिमिटेड की संपत्ति है। इसका प्रयोग अन्य अर्थों में बिना लिखित अनुमति के बिना न किया जाय।

निर्माण प्रमाण
SIGN & DATE

सामग्री सूची संख्या
INVENTORY NO.

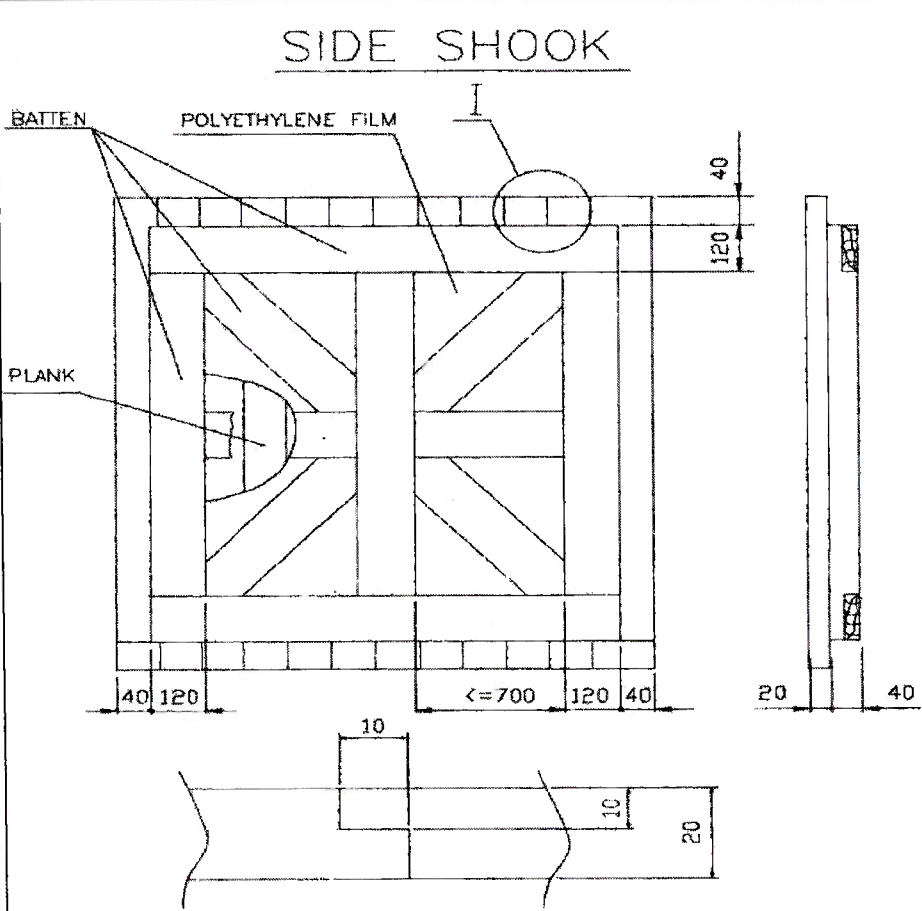

DETAIL - I

* DIMENSIONS SHOWN IN ABOVE FIGGURE ARE INDICATIVE ONLY.

It is preferable to have a single piece of the above multi-layered polyethylene sheet fixed on the four sides. In case jointing is unavoidable, it should be done by overlapping of approximately 100 mm.

Place the Components/cartons with corrosion inhibitors duly applied wherever necessary for place suitably, thin muslin cloths bags containing minimum 100 grams (approx.) of activated Blue Silica Gel as per IS 3401-1992/ BS 3482-1991 with standard particle size of 3 to 6 mesh (5.6 to 2.8mm), wherever necessary. Alternatively, VCI Powder as per IS 6263-1972/ IEC 68-2-30:1980 or Tablet may be used. Approximately 7 m3 VCI paper is necessary for 1 m3 of packed item. VCI Paper shall not be used for components made of aluminum, aluminum alloys, Zinc, Copper, Brass, cadmium & silver. VCI powder is sprinkled inside the piping components ends and shall be protected with end cover.

REV. NO. 02

निर्माणकर्ता
WORKED BY

जांचकर्ता
CHECKED BY

BRIJ LAL RAM



LAXMIKANT MISHRA

Brijlal

[Signature]

23/03/18

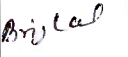
23/03/18

निर्यात एवं इन्वेंटरी SIGN & DATE		उत्पाद मानक (हीप : हरिद्वार) PRODUCT STANDARD (HEEP: HARIDWAR)		ST33002 पृष्ठ 10 का 8 Page 8 of 10		
सुपरसेड इन्वेंटरी SUPERSEDES INVENTORY	<p>All packages shall be covered on all sides with suitable GI sheets.</p> <p>4.4.8 Cover the whole equipment with polyethylene sheet of at least 120 GSM, on all sides preferably by a single piece.</p> <p>4.4.9 Silica gel is used for this purpose to protect the contents over sufficiently long time from corrosion. At the time of use, silica gel should be so dried that its color becomes dark blue. These shall be filled in small cotton bags. Before sealing the equipment, the silica gel bags should be kept inside the polyethylene film cover at different locations. The quantity of silica gel should not be less than 2.0 Kg per m3 volume of the packing box.</p> <p>4.4.10 Each case shall contain a packing list showing the detailed contents of the package. When any technical documents are supplied along with the shipment of materials no single package shall contain more than one set of such documents. Shipping papers shall clearly indicate in which packages the technical documents are contained.</p> <p>4.4.11 The case number shall be written in the form of a fraction, the numerator of which is the serial number of the case and the denominator the total number of case in which a complete unit of equipment is packed.</p> <p>4.4.12 Wherever necessary besides usual Inscriptions the cases shall bear special indication such as "Top", "Do not turn over", "Care", "Keep dry", etc., as well as indication of the center of gravity (with red vertical lines) and places for attaching slings (with chain marks). For all fragile equipment, unit should take special care to pack and label with additional markings such as " FRAGILE, HANDLE WITH CARE", "LIFTING POINTS", "THIS WAY UP", " DO NOT STACK" etc. to protect them from damage in transit.</p> <p>4.4.13 Completeness of Contents of each packing case:</p> <p>Concerned CQA/Unit QC/Third Party Inspection Agency shall verify the completeness of contents of each package w.r.t. packing list both in terms of quality and quantity before authorizing dispatch of the consignment.</p> <p>Packing commensurate with international standards and accepted norms will be ensured by CQA/ Unit QC/Third Party Inspection Agency. Packing has to be sea-worthy and secure. As far as possible, the packing has to be rectangular in shape for optimum space utilization in the ship and economize on shipping costs. Projections on packages are prohibited.</p>					
कॉपीराइट एंड कॉन्फिडेंशियल COPYRIGHT AND CONFIDENTIAL The information on this documents is the property of Bharat Heavy Electrical Limited. It must not be used directly or indirectly in any way detrimental to the interest of the company						
स्वत्वाधिकार एवं गोपनीय स्वत्वाधिकार एवं गोपनीय इस दस्तावेज में की गई सूचना भारत हेवी इलेक्ट्रिकल्स लिमिटेड की सम्पत्ति है इसका प्रयोग एवं प्रकाशन अन्य से किसी भी प्रकार में बिना इस कम्पनी के लिखित अनुमति के नहीं किया जाये।						
निर्यात एवं इन्वेंटरी SIGN & DATE						
सामग्री सूची संख्या INVENTORY NO. P-5284	REV. NO. 02		निर्माणकर्ता WORKED BY	BRIJ LAL RAM		23/03/18
			जांचकर्ता CHECKED BY	LAXMIKANT MISHRA		23/03/18

SUPERSEDES INVENTORY
 सामग्री सूची, संख्या को अधिकतम करना है

4.4.14 Completeness of Contents of each packing case:
 The packing list has to be checked and certified by the Inspection agency with due signatures. All packages shall be enclosed in suitable GI sheets on all sides. The top of box should be covered by GI sheet in single length & width.

No loose items Gunny bag packing is allowed for shipment.

4.4.15 Provision of Inspection Windows on Packages:
 Vendors should provide inspection window of size 6" x 4" (glass perplex) for customs examination for all packages (above 1.5 x 1.5 x 1.5 cum) involving panels of any kind. Care would be taken to ensure that all packages are properly sealed to avoid ingress of moisture, rodents etc. Packing slip folders shall be attached outside with each box.

4.4.16 Provision of Humidity Indicator:

- i. Humidity indicator must be provided in each packing boxes. Humidity indicator shall be placed behind inspection window or as far as practicable from the nearest unit of desiccant.
- ii. Use a three-spot paper card type 1x4 inches in size to show humidity with instruction as indicated in figure below. The spots indicate relative humidity of 50 percent, 40 percent and 30 percent, top to bottom, by changing color from blue to pink.

HUMIDITY INDICATOR

EXAMINE ITEM IF PINK	50
CHANGE DESSICANT IF PINK	40
WARNING IF PINK	30

4.4.17 Marking for Safe Handling:
 To ensure safe handling, packing case shall be marked to show the following:

- i. Upright position.
- ii. Sling position and Centre of Gravity position.
- iii. Storage category.

Fragile components (to be marked properly with a clear warning for safe handling).

COPYRIGHT AND CONFIDENTIAL
 The information on this documents is the property of Bharat Heavy Electrical Limited It must not be used directly or indirectly in any way detrimental to the interest of the company

स्वत्वाधिकार एवं गोपनीय
 इस प्रलेख में दी गई सूचना भारत भारती लिमिटेड का संपत्ति है इसका प्रयोग एवं प्रकाशक रूप में किसी भी प्रकार से बिना भारत भारती लिमिटेड के लिखित अनुमति के किया जाना नहीं है

निष्कापक संख्या
SIGN & DATE
[Signature] 23/03/18

सामग्री सूची संख्या INVENTORY NO. <i>P-59284</i>	REV. NO. 02		निर्माणकर्ता WORKED BY BRIJ LAL RAM	<i>Brij Lal</i>	23/03/18
			जांचकर्ता CHECKED BY LAXMIKANT MISHRA	<i>Laxmi Kant</i>	23/03/18

SUPERSEDES INVENTORY
 मासिक सूची संख्या में प्रतिबिम्बित करना है

4.4.18 Shipping Documentation including those covered by customs requirements:

- i. Packing List (O&M manual to be listed in packing list, if sent along with consignment).
- ii. Fumigation certificate for wooden boxes

4.4.19 THE FOLLOWING DETAILS ARE TO BE MARKED ON THE PACKING CASES:

- a) Address of consignee.
- b) Purchase Order No.
- c) Description of item or title of packing list.
- d) Case identification Number.
- e) Net Weight.
- f) Gross Weight.
- g) Dimensions of box
- h) Marking showing upright position.
- i) Marking showing umbrella (i.e. for machines/ components to be stored under covered storage).

MARKING ON PACKING BOXES

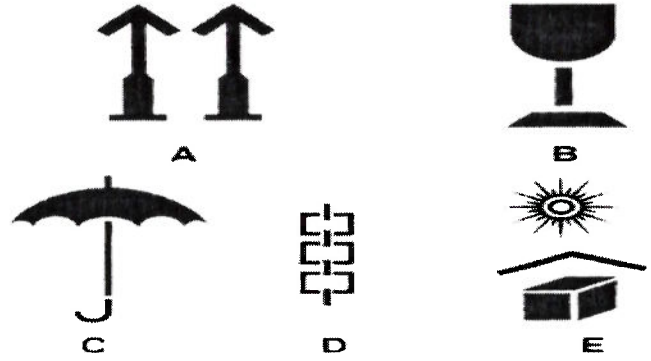

- A** UPRIGHT
- B** FRAGILE
- C** PROTECTION FROM FALLING OR CONDENSING MOISTURE
- D** SLING POSITION
- E** PROTECTION FROM DIRECT RADIATION

5.0 CROSS REFERED STANDARD:
 IS 3401-1992, BS 3482-1991, IS 6263-1972 & IEC 68-2-30:1980.

COPYRIGHT AND CONFIDENTIAL
 The information on this documents is the property of Bharat Heavy Electrical Limited. It must not be used directly or indirectly in any way detrimental to the interest of the company

स्वत्वाधिकार एवं गोपनीय
 इस प्रलेख में दी गई सूचना भारत भारती लिमिटेड की संपत्ति है। इसका प्रयोग एवं आशयक रूप में किसी भी प्रकार का प्रयोग जो कि कंपनी के हित में हानिकारक हो न किया जाय।

विनामक एवं तारीख
SIGN & DATE
(Handwritten signature and date)

मासिक सूची संख्या INVENTORY NO. <i>P-5284</i>	REV. NO. 02		निर्माणकर्ता WORKED BY BRIJ LAL RAM	<i>Brij Lal</i>	<i>23/03/18</i>
			जांचकर्ता CHECKED BY LAXMIKANT MISHRA	<i>(Signature)</i>	<i>23/03/18</i>