



BHARAT HEAVY ELECTRICALS LIMITED

(A Govt. of India Undertaking)
2x660 MW MAITREE STPP
RAMPAL, BAGERHAT, BANGLADESH

TENDER No:- MSTPP:ELECT:CONSTPOWER:O&M_TENDER/05-2022/001/T1

Date: 05/06/2022

LIST OF TENDER DOCUMENTS

01. TABLE OF CONTENTS	Page No. 01
02. NOTICE INVITING TENDER	Page No. 02
03. PRE-QUALIFICATION CRITERIA (ANNEXURE – I)	Page No. 16
04. NO DEVIATION CERTIFICATE (ANNEXURE – II)	Page No. 18
05. FORMAT FOR SEEKING CLARIFICATION (ANNEXURE – III)	Page No. 19
06. GENERAL CONDITIONS OF CONTRACT (VOLUME – I)	Page No. 20
07. PRICE SCHEDULE (VOLUME – II)	Page No. 27

TOTAL PAGES OF TENDER DOCUMENTS : 31 PAGES

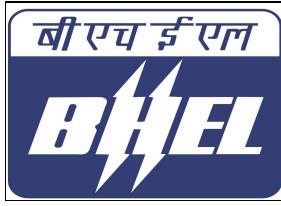

BHARAT HEAVY ELECTRICALS LIMITED

(A Govt. of India Undertaking)
2x660 MW MAITREE STPP
RAMPAL, BAGERHAT, BANGLADESH

TENDER No:- MSTPP:ELECT:CONSTPOWER:O&M_TENDER/05-2022/001/T1

Date: 05/06/2022

NOTICE INVITING TENDER (NIT)

Open Tender

**Operation & Maintenance (O&M) of the
Construction Power Network for a period of 12
Months wef 01/07/2022 to 30/06/2023 at 2X660
MW, MSTPP, Rampal, Bagerhat, Bangladesh**

**BHARAT HEAVY ELECTRICALS LIMITED
(A GOVT. OF INDIA UNDERTAKING)
POWER SECTOR – EASTERN REGION
2 X 660 MW MSTPP, Rampal, Bagerhat, Bangladesh**

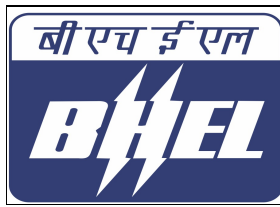
**BHARAT HEAVY ELECTRICALS LIMITED**

(A Govt. of India Undertaking)
2x660 MW MAITREE STPP
RAMPAL, BAGERHAT, BANGLADESH

TENDER No:- MSTPP:ELECT:CONSTPOWER:O&M_TENDER/05-2022/001/T1**Date: 05/06/2022****NOTICE INVITING TENDER (NIT)****Ref: MSTPP:ELECT:CONSTPOWER:O&M_TENDER/05-2022/001/NIT****Date: 10/06/2022**

SEALED OFFERS are invited from **REPUTED AND EXPERIENCED LOCAL BIDDERS** (meeting Pre-Qualification Criteria as mentioned IN Annexure – I) for the subject job by the undersigned on behalf of BHARAT HEAVY ELECTRICALS LIMITED as per the tender document.

ISSUE OF TENDER TO ANY BIDDER SHALL NOT CONSTRUCT THAT THE BIDDER IS CONSIDERED TO BE QUALIFIED. FOLLOWING POINTS RELEVANT TO THE TENDER MAY PLEASE BE NOTED AND COMPLIED WITH:

SALIENT DETAILS OF NIT

Sl no	Issue	Description	
i	TENDER NUMBER	MSTPP:ELECT:CONSTPOWER:O&M_TENDER/05-2022/001/T1 , DATE: 05/06/2022	
ii	SUBJECT OF THE JOB	Open Tender for Operation & Maintenance (O&M) of the Construction Power Network for a period of 12 Months wef 01/07/2022 to 30/06/2023 at 2X660 MW, MSTPP, Rampal, Bagerhat, Bangladesh	
iii	DETAILS OF TENDER DOCUMENT		
a)	Volume – I	GENERAL CONDITIONS OF CONTRACT (GCC)	Applicable
b)	Volume – II	PRICE SCHEDULE (ABSOLUTE VALUE)	Applicable
c)	Annexure – I	PRE-QUALIFICATION CRITERIA	Applicable
d)	Annexure - II	NO DEVIATION CERTIFICATE	Applicable
e)	Annexure - III	FORMAT FOR SEEKING CLARIFICATION	
iv	ISSUE OF TENDER DOCUMENTS	In BHEL website (https://www.bhel.com/tenders): For tender view & download purpose only.	Applicable
v	DUE DATE & TIME & ADDRESS OF OFFER SUBMISSION	TENDER START DATE :: 11/06/2022 (09:00 Hrs) DUE DATE OF OFFER SUBMISSION :: 20/06/2022 (15:00 Hrs) Offer to be submitted in the form of Hard copy to the following address: Shri Mrinal Kanti Sana CM, Electrical & C&I Bharat Heavy Electricals Ltd., Power Sector Easter Region, 2X660 MW Maitree Super Thermal Power Project, Upazilla: Rampal, Dist: Bagerhat, Division: Khulna, Bangladesh, Pin code: 9340	Applicable
vi	OPENING OF TECHNO-COMMERCIAL BID OF TENDER	21/06/2022 (12:00 Hrs)	Applicable
	OPENING OF PRICE BID OF TENDER	22/06/2022 (12:00 Hrs)	Applicable
vii	CURRENCY	BANGLADESHI TAKA (BDT)	Applicable

**BHARAT HEAVY ELECTRICALS LIMITED**

(A Govt. of India Undertaking)
2x660 MW MAITREE STPP
RAMPAL, BAGERHAT, BANGLADESH

TENDER No:- MSTPP:ELECT:CONSTPOWER:O&M_TENDER/05-2022/001/T1**Date: 05/06/2022**

viii	COST OF TENDER	NIL	Applicable
ix	LAST DATE OF SEEKING CLARIFICATION	16/06/2022 (12:00 Hrs)	Applicable
x	EMD AMOUNT	BDT 84,000.00 (BDT Eighty Four Thousand Only)	Applicable
xi	SD AMOUNT	5 % of the Awarded Contract Value	Applicable
xii	SCHEDULE OF PRE-BID DISCUSSION (PBD)	Not Applicable here.	Not Applicable
xiii	LATEST UPDATES	Latest updates on the Important Dates, Amendments, Correspondences, Corrigenda, Clarifications, Changes, Errata, Modifications, Revisions, etc.to Tender Specifications will be hosted in BHEL webpage only. Please go to www.bhel.com → Tender Notice. Bidders to keep themselves updated with all such information.	Shall be intimated over mentioned webpage

Description	Documents to be Submitted
GENERAL PART	<ol style="list-style-type: none"><u>Covering Letter</u> :: Signed & Stamped copy of Covering letter of Offer by Authorized Representative of the Bidder.<u>Entire Tender Documents</u> :: Signed & Stamped copies of all the pages of entire Tender Documents. Signature and Stamp should be at the bottom of the pages.<u>Filled-in Formats</u> :: Filled-in and Signed & Stamped copies of the<ol style="list-style-type: none">Format as given in GCC (Volume – I) andFormat at the end of Pre-Qualification Criteria (Annexure – I) (FORMAT TO BE FILLED-IN & SUBMITTED BY BIDDER ALONGWITH DOCUMENTS OF PRE-QUALIFICATION CRITERIA) by Authorized Representative of the Bidder.<u>No Deviation Certificate</u> :: Signed & Stamped copy of No Deviation Certificate (Annexure - II) in bidder's letterhead by Authorized Representative of the Bidder.
PRE-QUALIFICATION PART	<ol style="list-style-type: none"><u>Supporting Documents for Pre-Qualification</u> :: Signed & Stamped copies of all the necessary supporting documents etc., as applicable in case of Pre-Qualification Criteria (Annexure – I) by Authorized Representative of the Bidder.
PRICE BID PART	<ol style="list-style-type: none">Bidder must sign with stamp at the bottom on (A) PREAMBLE and at the designated place in (B) PRICE SCHEDULE REV 0.0 of Price Schedule (Volume – II.)Bidder must duly fill-in the best rates in (B) PRICE SCHEDULE REV 0.0 of Price Schedule (Volume – II) and check whether all fields have been covered aptly.The Price Schedule is to be submitted in a separate sealed envelope as COVER-II after filling-in. Any other document uploaded in the price bid, apart from tendered Price schedule, shall not be taken into cognizance for evaluation of offer.

The aforementioned parts shall be sent in Two Separate Sealed Envelopes/Covers as segregated hereunder:

ENVELOPES / COVER NO.	SHALL CONTAIN FOLLOWING PARTS
COVER – I (TECHNO-COMMERCIAL BID)	The following should be grouped in together by the Bidder: <ul style="list-style-type: none">All the documents as mentioned in GENERAL PART and PRE-QUALIFICATION PART above.
COVER – II (PRICE BID)	The following should be grouped in together by the Bidder: <ul style="list-style-type: none">All the documents as mentioned in PRICE BID PART above.



BHARAT HEAVY ELECTRICALS LIMITED

(A Govt. of India Undertaking)
2x660 MW MAITREE STPP
 RAMPAL, BAGERHAT, BANGLADESH

TENDER No:- MSTPP:ELECT:CONSTPOWER:O&M_TENDER/05-2022/001/T1

Date: 05/06/2022

This preface part has been construed as part of Tender Document and shall be read along-with others Volumes of Tender. Unless otherwise specified, in case of any confusion of any clause/ provision of this preface or any conflict/ inconsistency of any clause/ provision of this preface with that of other volumes, the same shall be brought out by the Bidder in writing to BHEL for clarification or during pre-bid discussions, if applicable, failing which most stringent interpretation in favour of BHEL shall be adopted and the same shall be binding to the bidder.

All the tender clauses are individually applicable for Contract unless specifically mentioned separately/differently, as applicable. The contractor shall arrange and comply with all the rules and regulations of Bangladesh authorities, all statutory laws including minimum wages, workmen compensation etc. All registration and statutory inspection fees, if any, in respect of the work executed by the contractor shall be to his account.

CLAUSE NO	DESCRIPTION
1.0	Project Information
1.1	<p>Introduction</p> <p>Project Name : 2X660 MW MAITREE SUPER THERMAL POWER PROJECT Name of the Owner : BIFPCL Capacity : 2 X 660 MW</p> <p>The project is located in Rampal Upazila of Bagerhat District between latitude and longitude of 22 deg. 37' 0" N to 22 deg. 34' 30" N and 89 deg. 32' 0" E to 89 deg. 34' 5' E respectively.</p> <p>Site is 14 KM northeast of Mongla port and 14 KM northwest of Sundarban and is infringed by Posur & Moidara to the west & south east respectively.</p> <p>It is essential that the bidder visit site and acquaint with the conditions prevailing at site before submission of the bid. The information given herein is for general guidance and shall not be contractually binding on BHEL.</p> <p>Nearest Town : Mongla (14 KM)</p> <p>Nearest Commercial Airport : Jesore (107 km from Project site)</p>

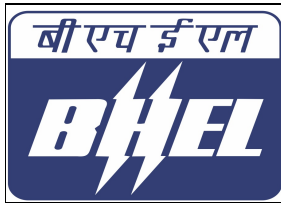

BHARAT HEAVY ELECTRICALS LIMITED

(A Govt. of India Undertaking)
2x660 MW MAITREE STPP
 RAMPAL, BAGERHAT, BANGLADESH

TENDER No:- MSTPP:ELECT:CONSTPOWER:O&M_TENDER/05-2022/001/T1

Date: 05/06/2022

1.2	Approach to Site The nearest town Khulna is at a distance of 23 km from project site. The site is Connected by road from Mangla- Khulna Highway. Nearest Domestic airport is Jessor, Bangladesh at a distance of about 107 KM and international airport is Dhaka at a distance of 263 KM, Bangladesh
2.0	Site Visit The contractor should visit project site and acquire full knowledge and information about site conditions. The bidder must visit site, to acquaint himself with the conditions prevailing at site and in and around the plant premises, together with all the statutory, obligatory, mandatory requirements of various authorities before submission of the bid.
3.0	33 KV & 11 KV Supply Line Diagram at 2 X 660 MW MSTPP

33KV SUPPLY FROM MONGLA 132/33KV S/S THROUGH 33KV LINE EXECUTED BY WZPDCL (LINE LENGTH-17KM) ⚡

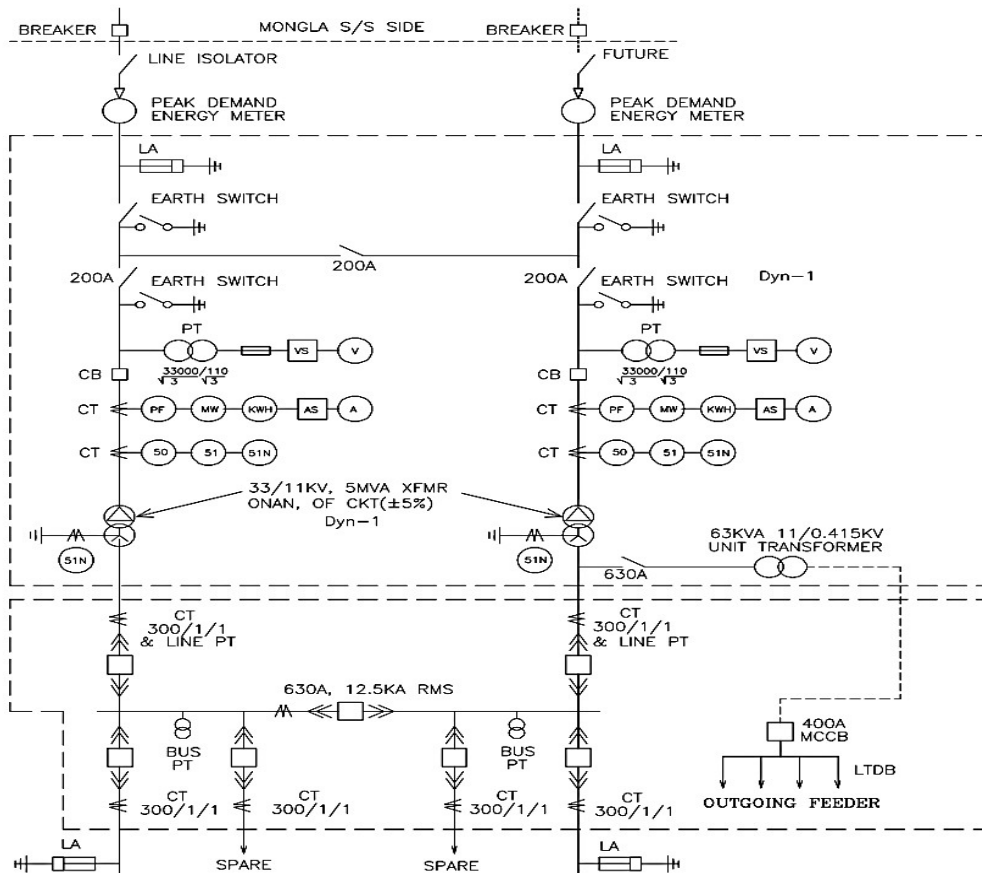

पावर सेक्टर पूर्वी क्षेत्र (मुख्यालय)

POWER SECTOR EASTERN REGION, DJ-9/1, SALLAKECITY, KOLKATA - 700 091

फैक्स/Fax:(033) 23211960 फ़ोन/Phone:बोर्ड/EPABX: 23398220

Page-6 of 31



BHARAT HEAVY ELECTRICALS LIMITED

(A Govt. of India Undertaking)
2x660 MW MAITREE STPP
RAMPAL, BAGERHAT, BANGLADESH

TENDER No:- MSTPP:ELECT:CONSTPOWER:O&M_TENDER/05-2022/001/T1

Date: 05/06/2022

(A) Important Instructions regarding Participating in Tender	
Clause No.	Descriptions
1.0	The offer shall be sent as per following details in separate sealed envelopes containing of TWO COVERS. Complete set of Offer shall be sent: To Shri Mrinal Kanti Sana, CM, Electrical & C&I Bharat Heavy Electricals Ltd., Power Sector Easter Region, 2X660 MW Maitree Super Thermal Power Project, Upazilla: Rampal, Dist: Bagerhat, Division: Khulna, Bangladesh, Pin code: 9340
2.0	All documents/ annexures submitted with the offer shall be properly annexed and placed in respective places of the offer as per enclosure list mentioned in the covering letter. BHEL shall not be responsible for any missing documents
3.0	The bidder may also consult this office before submitting their offers, for any clarifications regarding any clarification/queries related to the tender as per ANNEXURE – III: Format for seeking clarification. LAST DATE OF SEEKING CLARIFICATION :: 16/06/2022 (12:00 Hrs) Since the job shall be executed at BIFPCL/MAITREE, RAMPAL, BAGERHAT Site, bidders must visit site/ work area and study the job content, facilities available, availability of materials, prevailing site conditions including law & order situation etc. before quoting for this tender. They may also consult this office before submitting their offers, for any clarifications regarding scope of work, facilities available at sites or on terms and conditions. No additional claim shall be entertained by BHEL in future, on account of non-acquaintance of above.
4.0	Bidders to note specifically that all pages of tender document, including these NIT pages for this particular tender shall be submitted by them (after signing/stamping on each page) as a part of their offer. Price shall not be mentioned by them anywhere in the techno-commercial portion of offer, it shall be mentioned in the relevant price schedule only and submitted in separate sealed envelope. In case of any clarification, bidder may contact this office as mentioned above.
5.0	All the documents submitted with the offer shall be signed & stamped in each page by the Bidder or the authorised representative. No overwriting/ correction in tender documents by bidders shall be allowed. However, if correction is unavoidable, the same may be signed by authorized signatory.
6.0	No Deviation with respect to Tender Clauses and no additional clauses/ suggestions/ clarification in Techno-commercial Bid/ Price Bid shall normally be considered by BHEL. Bidders are requested to positively comply with the same. Offers with deviation are liable for rejection. The Bidder shall have to submit No Deviation Certificate in his Letterhead with due signature and stamp as per the format given in Annexure – II.
4.0	The Price Bids of only those bidders will be opened who will be qualified for the subject job on the basis of Pre-Qualification Criteria in Techno-Commercial Bids, (as in Annexure – I). BHEL's decision in this regard shall be final & binding to the bidder. BHEL also reserve the right to reject the bidder with unsatisfactory past performance in execution of a contract. BHEL's decision in this regard shall be final & binding to the bidder.
5.0	The bidder may depute their authorized representative during the opening of techno-commercial Bid & Price Bid as per schedule. One authorized representative of the bidder shall be allowed to attend the bid opening.
6.0	However, BHEL will go ahead with the opening of bids (Techno-Commercial Bid/ Price Bid) in the case non-availability of bidder representative.
7.0	Validity of all the Price offer shall be of Six (06) Months from the due date of Tender submission (Including extension, if any).
8.0	The bidders shall not enter into any undisclosed M.O.U. or any understanding amongst themselves with respect to tender.
9.0	Bidders to note specifically that all pages of tender document, including these NIT pages for this particular tender shall be submitted by them (after signing/stamping on each page) as a part of their offer. Price shall not be mentioned by them anywhere in the techno-commercial portion of offer, it shall be mentioned in the relevant price schedule only and submitted in separate sealed envelope. In case of any clarification, bidder may contact this office.

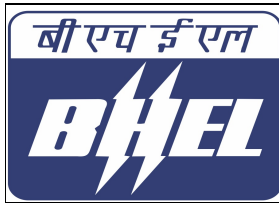

BHARAT HEAVY ELECTRICALS LIMITED

(A Govt. of India Undertaking)
2x660 MW MAITREE STPP
RAMPAL, BAGERHAT, BANGLADESH

TENDER No:- MSTPP:ELECT:CONSTPOWER:O&M_TENDER/05-2022/001/T1

Date: 05/06/2022

10.0	The bidder may have to produce Original Document(s) for verification, if so, decided by BHEL.
11.0	Successful bidder shall have to submit additional set of tender/sign on tender document provided by BHEL, if so decided by BHEL.
12.0	BHEL reserves the right to accept or reject any or all offer without assigning any reasons thereof. BHEL also reserve the right to cancel the tender wholly or partly without assigning any reason thereof. In addition, BHEL shall not entertain any correspondence from bidders in this matter
13.0	BHEL may decide holding Pre-bid Discussion [PBD] with all intending bidders. On such communication from BHEL, the bidder shall ensure participation for the same at the appointed time, date and place as may be decided by BHEL. Outcome of PBD (if any) shall also form part of tender.
14.0	In case of absence of any queries from bidder(s), their quoted price will be PRESUMED to be final and complete with reference to the tender documents (including Tender change notices (TCNs), clarifications, corrigendum issued by BHEL, if any). Bidders are requested to study the tender documents in detail and prepare their queries/clarifications accordingly. All such queries / clarifications shall be cleared/replied by BHEL. Such clarification letters, corrigendum and/or Tender change notices (TCNs), if issued by BHEL, shall form part of tender document.
15.0	In the event of any conflict between requirement of any clause of this specification/ documents /drawings /data sheets etc. or requirements of different codes/ standards specified/ contradictions between any two clauses of tender document, the same to be brought to the knowledge of BHEL by bidders in writing for clarification before due date of seeking clarification, otherwise, more stringent requirement as may be interpreted by BHEL shall prevail and shall be binding on you. Any typing error/missing pages/other clerical errors in the tender documents, noticed by the Bidder must be pointed out before submission of offer, or else, BHEL's interpretation shall prevail & binding on the Bidder.
16.0	Unless specifically mentioned otherwise, bidder's quoted price shall deem to be in compliance with tender including PBD.
17.0	Tender document containing above mentioned Volumes & Annexures shall be signed & stamped in all pages including this covering letter. Price bid shall be furnished in the specified format enclosed with the tender. Any additional copy, if required, may be taken by photocopying from the tender document given in the web, if any.
18.0	The bidder shall submit documents in support of possession of 'Pre-Qualification Criteria' duly self-certified and stamped by the authorized signatory, indexed and properly linked in the format for PQR. In case BHEL requires any other documents/proofs, these shall be submitted immediately (if applicable).
19.0	BHEL reserves the right to open the price bid of the offers in camera, the date & time to open the tender opening shall be intimated to the bidders in case BHEL decides it to be 'Public Opening' and in such a case, one authorized representative of the bidder shall be allowed to attend.
20.0	Bidders are required to submit their BEST price as per tender Price Schedule format in the form & manner as mentioned in tender.
21.0	Price Bids shall be evaluated as the Total Price as quoted. However, Unit Rates shall also be furnished, if applicable, in the Price Schedule.
22.0	Bid should be free from correction, overwriting, using corrective fluid, etc. Any interlineation, cutting, erasure or overwriting shall be valid only if they are self-attested under full signature(s) of person(s) signing the bid else bid shall be liable for rejection.
23.0	Taxes and duties shall be as per PART- C of the tender. Statutory variation of taxes and duties (plus or minus) in accordance with Govt. Notifications to the account of BHEL. Any imposition of new / additional Duty / Tax at the time of supply shall be borne by BHEL.
24.0	Bidders are requested to note that the accepted / agreed tender terms (technical or commercial)in their original offer cannot be altered / withdrawn by their own during the processing of tender.
25.0	Unsolicited discounts received after opening of techno commercial bid shall not be considered for evaluation. However, if the party who has submitted the unsolicited discount/rebate becomes the L-1 party, then the awarded price shall be after considering the discount.
26.0	The offers of the bidders who are on the banned list as also the offer of the bidders, who engage the services of the banned firms, shall be rejected. The list of banned firms is available on BHEL web site www.bhel.com Integrity commitment, performance of the contract and punitive action thereof:

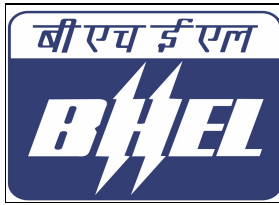

BHARAT HEAVY ELECTRICALS LIMITED

(A Govt. of India Undertaking)
2x660 MW MAITREE STPP
RAMPAL, BAGERHAT, BANGLADESH

TENDER No:- MSTPP:ELECT:CONSTPOWER:O&M_TENDER/05-2022/001/T1

Date: 05/06/2022

	<p>a) <u>Commitment by BHEL:</u></p> <p>i) BHEL commits to take all measures necessary to prevent corruption in connection with the tender process and execution of the contract. BHEL will during the tender process treat all Bidder(s) in a transparent and fair manner, and with equity.</p> <p>b) <u>Commitment by Bidder/ Supplier/ Contractor:</u></p> <p>i) The bidder/ supplier/ contractor commits to take all measures to prevent corruption and will not directly or indirectly influence any decision or benefit which he is not legally entitled to nor will act or omit in any manner which tantamount to an offence punishable under any provision of the Indian Penal Code, 1860 or any other law in force in India.</p> <p>ii) The bidder/ supplier/ contractor will, when presenting his bid, disclose any and all payments he has made, and is committed to or intends to make to agents, brokers or any other intermediaries in connection with the award of the contract and shall adhere to relevant guidelines issued from time to time by Govt. of India/ BHEL.</p> <p>iii) The bidder/ supplier/ contractor will perform/ execute the contract as per the contract terms & conditions and will not default without any reasonable cause, which causes loss of business/ money/ reputation, to BHEL.</p>
27.0	<p>The Bidder along with its associate/collaborators/sub-contractors/sub-vendors/consultants/service providers shall strictly adhere to BHEL Fraud Prevention Policy displayed on BHEL website http://www.bhel.com and shall immediately bring to the notice of BHEL management about any fraud or suspected fraud as soon as it comes to their notice.</p>
28.0	<p>If any bidder/ supplier/ contractor during pre-tendering/ tendering/ post tendering/ award/ execution/ post-execution stage includes in mal-practices, cheating, bribery, fraud or and other misconduct or formation of cartel so as to influence the bidding process or influence the price or acts or omits in any manner which tantamount to an offence punishable under any provision of the Indian Penal code, 1860 or any other law in force in India, then, action may be taken against such bidder/ supplier/ contractor as per extant guidelines of the company available on www.bhel.com and/ or under applicable legal provisions.</p>
28.0	<p>ORDER OF PRECEDENCE:</p> <p>In the event of any ambiguity or conflict between the Tender Documents, the order of precedence shall be in the order below:</p> <ol style="list-style-type: none">AMENDMENTS/CLARIFICATIONS/CORRIGENDA/ERRATA etc. issued in respect of the tender documents by BHEL.NOTICE INVITING TENDER (NIT)PRICE SCHEDULE: Volume – IIGENERAL CONDITIONS OF CONTRACT (GCC): Volume – I



BHARAT HEAVY ELECTRICALS LIMITED

(A Govt. of India Undertaking)
2x660 MW MAITREE STPP
 RAMPAL, BAGERHAT, BANGLADESH

TENDER No:- MSTPP:ELECT:CONSTPOWER:O&M_TENDER/05-2022/001/T1

Date: 05/06/2022

(B) Scope of Work with Terms & Conditions	
Clause No.	Descriptions
1.0	Scope
	The scope covers operation & maintenance of entire construction power system including but not limited to BHEL site office, residential colony, stores, storage & fabrication yard etc including providing all equipment/ materials, labour, supervision, T&Ps, consumables as detailed in the Technical specification and terms & conditions of tender taking into account all clarifications, confirmations and agreements till date for 2x660 MW Maitree Super Thermal power project at Moidara village, Rampal upazila, Bagerhat district, Bangladesh.
2.0	Taxes & Duties etc.
2.1	(i) All taxes, Charges, Royalties and other Taxes for the work and for the execution of the contract shall be borne by the Bidder and shall not be payable extra by BHEL. (ii) The Bidder shall accept The Bidder rates/ price inclusive of all taxes, duties as mentioned above etc, together with variation thereto during contract period including extension, if any. BHEL shall not release any additional payment in this regard. (iii) The Bidder should have valid VAT Registration Number and 12 digit TIN number in Bangladesh prior to start of work. (iv) The Bidder must issue VAT INVOICE as per said law. If VAT is exempted subsequently, the applicable VAT rate of BANGLADESH and amount thereof will not be payable and will be deducted from Gross Amount charged to BHEL. (v) A.I.T under Income Tax Act of Bangladesh, VAT etc shall be deducted at prevailing rates on Gross Invoice Value from the bills unless Exemption Certificate from the appropriate authority/ authorities is/ are furnished (vi) The Bidder are responsible for The Bidder own Income Tax Liability, if any and BHEL will not bear any such liability.
2.2	New tax & duties, if imposed subsequent to latest due date of offer submission, as per NIT & TCN, as applicable, by statutory authority after due date of submission of latest price offer and within the contract period including extension, if any (provided reason for extension is not attributable to The Bidder), shall be reimbursed by BHEL at actual on production of relevant supporting document to the satisfaction of BHEL. However, The Bidder shall obtain prior approval from BHEL before depositing new taxes & duties.
3.0	Security Deposit
3.1	There will be a Security Deposit which will be calculated while releasing out the WO.
3.2	Upon acceptance of Tender, the successful Tenderer should deposit the required amount of Security Deposit for satisfactory completion of work and the security amount will be 5 % of the awarded contract value
3.3	The security Deposit should be furnished before start of the work by the contractor
3.4	Security Deposit may be furnished in any one of the following forms > Cheque in favour of BHEL in SBI, Khulna, Bangladesh(BDT A/c. No. 05620257520201) > Pay Order / Demand Draft in favour of BHEL in SBI, Khulna, Bangladesh NB: At least 50% of the Security Deposit should be deposited in any form as prescribed above before start of the work and the balance 50% may be recovered from the running bills. NB: Security deposit shall not carry any interest.
4.0	Earnest Money Deposit (EMD)
	Every Bidder must be accompanied by the prescribed amount of <u>Earnest Money Deposit (EMD)</u> in the manner as described herein :- i) EMD shall be furnished along with the OFFER in full as per the amount indicated as follows :- > 84,000.00 (BDT Eighty Four Thousand Only) ii) EMD is to be paid in :- > Cheque in favour of BHEL in SBI, Khulna, Bangladesh (BDT A/c. No. 05620257520201) > Pay Order / Demand Draft in favour of BHEL in SBI, Khulna, Bangladesh iii) No other form of EMD remittance shall be acceptable to BHEL iv) EMD to be deposited two days before Tender Opening date, otherwise the Bid is liable to be rejected. v) EMD by the bidder will be forfeited as per Tender Documents if :-



BHARAT HEAVY ELECTRICALS LIMITED

(A Govt. of India Undertaking)
2x660 MW MAITREE STPP
RAMPAL, BAGERHAT, BANGLADESH

TENDER No:- MSTPP:ELECT:CONSTPOWER:O&M_TENDER/05-2022/001/T1

Date: 05/06/2022

	<ul style="list-style-type: none">➤ After opening the tender, the bidder revokes his tender within the validity period or increases his earlier quoted rates.➤ The bidder does not commence the work within the stipulated period as per WO issued to it. In case the WO is silent in this regard then "within 15 days after award of contract" may presumed. <p>vi) EMD shall not carry any interest.</p> <p>vii) In the case of unsuccessful bidders, the Earnest Money will be refunded to them within a time frame of 30 days after acceptance of award by successful Bidder.</p> <p>viii) The amount of EMD will be adjusted to amount of SD while taken in account, for the successful Bidder.</p>
5.0	Completion Period of the O&M Contract The O&M Contract shall start from 01/07/2022 for a period of 12 Months i.e. will end on 30/06/2022.
6.0	Terms of Payment <p>(a) The Price for Operation & Maintenance will be paid in each month (Total = 12 months) as certified by BHEL Engineer.</p> <p>(b) Bidder shall submit the Bidder's Running Account Bill, signed by Bidder's appointed Power of Attorney, once in a month at the end of each month. The RA Bill complete in all respect, accompanied by BHEL Engineer's Certified Measurement Sheets, jointly signed, will be paid, subject to completeness and correctness. Income Tax and VAT at the prevailing rates on gross value of work done & applicable surcharge shall be deducted from The Bidder bill, unless exempted by the Income Tax Authority.</p> <p>(c) 100% net payment shall be released on satisfactory completion of job as certified by site authority, through BEFTN/Cheque to the Bank account, as provided by the L1 Bidder after finalization of Tendering process within 30 days from the date of submission of Bidder's Running Account Bill to BHEL Office, Maitree STPP</p> <p>(d) 5% will be retained from each bill which will be released on completion of Operation & Maintenance period in all respect as certified by site authority.</p> <p>(e) Payment shall be made in Bangladesh Taka.</p> <p>(f) The accepted rate of individual items shall remain Firm throughout the contract period including extension period, if any without any escalation.</p> <p>(g) The Bidder should have valid VAT Registration Number and 12 digit TIN Number in Bangladesh and the same is to be furnished during submission of Bills</p> <p>(h) The quotation should be valid at least for a period of SIX (06) MONTHS from the tender due date of submission (extended, if any).</p> <p>(i) Price Variation Clause (PVC) / Over Run Compensation (ORC) / Rate Revision are not applicable in this Tender.</p>
7.0	Mobilisation Advance / IBRA No mobilization advance/ IBRA will be paid to the Bidder.
8.0	Price Variation Clause/ Over Run Compensation Not applicable for this contract
9.0	Paying Authority Paying authority shall be Construction Manager (Electrical) of BHEL, 2X660 MW MSTPP, Rampal Site.
10.0	Insurance for Machineries/Equipments & Manpower Bidder shall arrange Insurance for all machineries/equipments as well as employed Manpower, covered under this package.
11.0	Medical of Manpower Bidder shall arrange Medical Check-up of all the Manpower, during processing of Gate-Passes and during any routine/sudden health assessment on his own expense. Provision of First-Aid Treatment relating to 11KV Electrical Hazards/Electrocutions should be present with the Bidder at all times.
12.0	Uniforms of Manpower Bidder shall arrange proper Uniforms for all the Manpower, during the working-time inside Plant premises. The Uniforms should be of 2 sets for each employee.
13.0	Accommodation for Manpower



BHARAT HEAVY ELECTRICALS LIMITED

(A Govt. of India Undertaking)
2x660 MW MAITREE STPP
 RAMPAL, BAGERHAT, BANGLADESH

TENDER No:- MSTPP:ELECT:CONSTPOWER:O&M_TENDER/05-2022/001/T1

Date: 05/06/2022

	Bidder shall arrange suitable Accommodation for all the Manpower, inside/outside the MSTPP Plant premises, for the whole period of the Contract. BHEL will not be liable for any sort of dispute/claims/compensations arising out of this issue in any means or in any nature thereof.
14.0	Safety Appliances for Individual & 11KV Network Bidder shall be liable to provide all sort of Safety Appliances/ Personal Protective Equipments (PPEs) for Individual Manpower as well as the 11KV Construction Network, required for the Operation & Maintenance of the Contract.
15.0	Charges for Mobile Handsets and Monthly Mobile Bills Bidder shall ensure payment of Charges for Mobile Handsets and Monthly Bills of each & every Manpower for the smooth and effective communication among Supervisors and Workers during overhauling/maintenance/emergency restoration jobs at Site.
16.0	Required T&Ps & Consumables During the O&M Contract of the Construction Power, Bidder shall ensure the true availability of required T&Ps at all times. <ul style="list-style-type: none"> ◆ Tentative List of T&Ps to be deployed by the Bidder within quoted rates:- <ol style="list-style-type: none"> 1. Crimping Tool of all Sizes 2. Box Spanner Sets 3. Vacuum Cleaner cum Blower 4. Handheld Multimeter (Digital – 1000V) 5. 2500 KV Hand Operated Insulation Tester 6. Earth Tester 7. Phase Sequence Tester 8. Handheld Emergency Light 9. Tong Tester upto 1000A 10. Other handheld tools like Screw Driver, Spanner, Pliers etc. 11. Tree/Grass Cutting Tools 12. Digging Tools 13. Flash Light/Torches 14. Folding Ladder 15. Rubber Gloves for 33/11 KV – 3 sets each 16. Hot Gun/Blower for Heat Sink of Cable Jointing Kit 17. Lever Hoist Ratchet Pulley Hoist (750 KG to 9000 KG) 18. HV Discharge Rod. ◆ Tentative List of Consumables to be deployed by the Bidder within quoted rates:- <ol style="list-style-type: none"> 1. PVC Insulation Tapes 2. White Spirit 3. Kerosene/Petrol/Diesel 4. Detergent/Soap/Cleaning chemicals 5. Gas for Heat Sink Work for End Joints 6. Other Consumables as required. • BHEL will not be responsible for any sort of delay in restoration time after due overhauling/maintenance of any portion of the network due to shortage/absence of required T&Ps and/or Consumables.
17.0	Local Transportation for shifting 11 KV Materials/T&Ps across the Plant The Bidder should maintain/perpetuate the means of transportation of important 11 KV Materials/T&Ps across the Plant for quick and prompt accomplishment of jobs at site. There will be no means of transportation to be provided by BHEL.
18.0	Liquidated Damage/ Penalty
18.1	Whenever any Manpower of the awarded Agency will be going on Leave, the Bidder has to positively arrange for Equivalent alternative Manpower in lieu of the same, who is going on Leave, well in advance. In case the Bidder fail to deploy requisite manpower as per direction of BHEL / Site and fail to operate and maintain the “Construction Power System”, and this non-functioning continues for more than one day, due to the Bidder fault, the Liquidated damage shall be levied @ 0.25% of the contract price (O&M part of the Price schedule) for such non-functioning of each day or part thereof . The liability for delay shall not in any case exceed 5% (five percent) of the contract price, including taxes, duties (O&M part of the price schedule).
18.2	All other terms shall be as per the provision of GCC of tender in this regard.



BHARAT HEAVY ELECTRICALS LIMITED

(A Govt. of India Undertaking)
2x660 MW MAITREE STPP
RAMPAL, BAGERHAT, BANGLADESH

TENDER No:- MSTPP:ELECT:CONSTPOWER:O&M_TENDER/05-2022/001/T1

Date: 05/06/2022

19.0	Nature of Duty & Manpower to be maintained			
	The Bidder shall provide round the clock (3 shift basis) Operation & Maintenance Services of entire Construction Power System installed inside MSTPP boundary including providing all equipment/ materials, labour, supervision, T&Ps, consumables etc with following Manpower as depicted below:-			
	SL NO	DESCRIPTION	NO OF PERSONS	REMARKS
	1	DIPLOMA ENGINEER	01 (ONE)	SHOULD HAVE 5 YRS OF EXPERIENCE
2	ELECTRICIAN	03 (THREE)		
3	ASSISTANT ELECTRICIAN	03 (THREE)		
The above staff shall be equipped with all tools & tackles required for providing successful services towards operation & maintenance both preventive & shutdown repairing/ maintenance round the clock along with all requisite consumables etc.				
Special Note on Charges of Deduction on absence of Manpower				
(i) During absence/leave of any Manpower of the aforesaid list, equivalent alternative Manpower should have to be provided. If the Bidder fails to do so and the absence prevails for more than <u>one day</u> , BHEL reserves the right to deduct the cost of the Manpower in pro-rata basis (with an Overhead of 30%) from the RA Bills starting from the <u>2nd day of the absence</u> of that Manpower.				
Additionally there will be a Penalty of Liquidated damage (as per Point No. 18.0 of (B) Scope of Work with Terms & Conditions of NIT), which will be levied @ 0.25% of the contract price (O&M part of the Price schedule) for such non-functioning of each day or part thereof. The liability for delay shall not in any case exceed 5% (five percent) of the contract price, including taxes, duties (O&M part of the price schedule).				
(ii) Payment of all Manpower should be cleared for each month within the first 7 days of the next month & Wage Sheet should be submitted to BHEL along with RA Bills . If BHEL experiences any sort of Manpower crisis or delay in Jobs due to problems arising out of the Non-timely Payment to the Manpower or O&M Manpower report to BHEL regarding the Non-timely Payment of Wages, BHEL reserves the right to recover that Manpower Wages as per the available record of previous submitted Wage Sheet from the RA Bills & to pay directly to the O&M Manpower and in those cases, an Overhead charges @ 30% of the amount paid for those wages of manpower, will be levied from the Bidder.				
20.0	Quality Assurance Program & Occupational Health, Safety & Environment Management			
20.1	BHEL, Power Sector Eastern Region (PSER) is ISO-9002 certified company. Quality of work to customer's satisfaction and system requirements are the essence of ISO-9002 certification. BHEL, PSER has also obtained HSE certification (ISO-14001 & OHSAS-18001). The Bidder will organize/ plan/ perform all The Bidder activities to meet with these standards. The Bidder's Engineers & Supervisors shall be adequately qualified and also inclined to do a quality job. The quality assurance engineer shall co-ordinate all aspects of quality control, inspection, implementation of quality assurance procedures laid down in Quality Plan and technical specification by BHEL. The Bidder shall fill up quality assurance log sheets/ formats and submit to BHEL for joint inspection and acceptance. The Bidder shall fill up, maintain & preserve the quality records in computerized media. BHEL's authorized representative shall be given free access at all time to such quality related records etc for inspection, review etc			
20.2	The Bidder shall adopt suitable quality assurance program to control activities as necessary. Such program shall be outlined by The Bidder and shall be finally accepted by the BHEL/ owner. The Bidder quality assurance program shall generally cover the following:-			
20.2.1	Bidder's Organization Structure and Qualification Data of Key Personnel for the Management and Implementation of the proposed Quality Assurance Program.			
20.2.2	System for site erection control including process controls and fabrication and assembly controls			
20.2.3	Control of non-conforming items and system for corrective actions.			

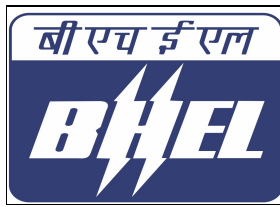

BHARAT HEAVY ELECTRICALS LIMITED

(A Govt. of India Undertaking)
2x660 MW MAITREE STPP
RAMPAL, BAGERHAT, BANGLADESH

TENDER No:- MSTPP:ELECT:CONSTPOWER:O&M_TENDER/05-2022/001/T1

Date: 05/06/2022

20.2.4	Inspection and test procedure for all site related works.
20.2.5	Calibration and testing of measuring and testing equipment (IMTEs) at appropriate intervals
20.2.6	System for quality audit
20.2.7	System for indication and appraisal of inspection status
20.2.8	System for maintenance of records.
20.3	The Bidder will comply with HSE (Health, safety & environment) requirements of BHEL. All applicable OCPs (Operational control procedures) will be followed by the bidder as per BHEL instructions. This will be done as part of normal scope of work. The Bidder will follow applicable OCPs, within accepted rates. Suitable measures will be taken by the bidder for waste management and environment related laws/ legislation as a part of normal construction activities.
20.3.1	The Bidder shall refer to BHEL HSE Manual No. HSEP:14-MAITREE: DATE:01.03.16 or customer's safety manual, available at site, and comply with its directives/ stipulations during execution of the job. In case of any recovery made by customer BIFPCL due to lapses on The Bidder part during execution, the same shall be recovered on back to back basis from The Bidder without prejudice to any other rights of the BHEL.
20.4	The Bidder shall ensure that all The Bidder staff/ employees are exposed to periodical training programmes conducted by qualified agencies/ personnel on ISO 9002 Standards.
21.0	Additional Health, Safety & Environment Management Clauses
	<p>In addition to existing clause of HSE of tender, following points will also be added to HSE clause to which the Bidder shall comply with in order to get the payment as enumerated above, The Bidder will follow HSE policy of BHEL/ PSER and work as per the safety guidelines which is in line with ISO:14001 and OHSAS:18001 standards, A list of the guidelines which should be strictly followed by the Bidder is as follows. The Bidder's scope shall not be limited to the followings (1.0 to 40.0) only but shall be guided by the HSE related policies/ guidelines of BHEL as revised to suit the requirement of the standards and statutory requirements.</p> <p>1.0 = Nominate a safety officer, preferably The Bidder Diploma Engineer, who will supervise all the HSE aspects. 2.0 = The safety officer will participate in all safety meeting conducted by BHEL. 3.0 = Submit site safety plan indicating safety measures to be taken, fire fighting equipments & PPE to be deployed. 4.0 = Report every near miss incident to BHEL. 5.0 = Report accident report immediately after the occurrence. 6.0 = Obtain operation control procedures (OCPs) from BHEL for the work to be executed 7.0 = Follow factory act. 8.0 = Every worker should use PPE as per his trade. All PPE should confirm to IS. 9.0 = Conduct tool box meeting with workers everyday before start of work instructing about the use of PPE. The outcome of the meeting to be recorded in a register. 10.0 = Check fitness of the PPE and lifting tackles weekly and record in a register which will be verified by BHEL. 11.0 = No person below 18 years will be employed. 12.0 = Deploy fire-fighting equipments and refill before expiry. 13.0 = Keep fire extinguishers of adequate type near the hot job and near the Electrical Machines. 14.0 = Copy of valid Test certificates of all T&Ps should be given to BHEL as soon as the item enters the project, without which the T&P can not be allowed to be used. 15.0 = No body will be allowed to work above 2 meters without safety belt/ harness with lifeline secured to a fixed member. 16.0 = Good housekeeping has to be maintained. All debris shall be removed from workplace within shortest possible time. 17.0 = Approach roads should not be blocked with cables, materials or debris. 18.0 = First aid boxes have to be kept and maintained with all requisite materials as per Factory act. 19.0 = Trained person has to be kept for giving first aid. 20.0 = Adequate illumination shall be provided where working. 21.0 = All vehicles should have backlight, reverse horn and reversing light. 22.0 = Crane operator shall have proper license. 23.0 = Crane should have reverse horn. 24.0 = Only skilled person maintain and operate electrical items. 25.0 = ELCB/RCCB/RCD has to be used. No temporary connection shall be allowed. 26.0 = All fuses shall have standard rating and capacity.</p>

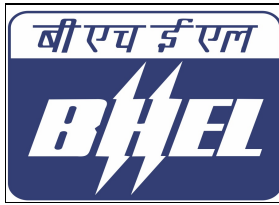

BHARAT HEAVY ELECTRICALS LIMITED

(A Govt. of India Undertaking)
2x660 MW MAITREE STPP
RAMPAL, BAGERHAT, BANGLADESH

TENDER No:- MSTPP:ELECT:CONSTPOWER:O&M_TENDER/05-2022/001/T1

Date: 05/06/2022

	27.0 = All power supply cables should be laid above 3 meter level or underground. 28.0 = All persons should have Height Pass. 29.0 = Water-logging of working area shall be removed. 30.0 = For operating portable machines 3 pin plugs shall be used. 31.0 = Oxygen and DA cylinders shall be separated labeling full or empty. Full cylinders shall be kept upright. 32.0 = Cylinders are not transported by rolling. 33.0 = All Oil Drums shall be kept horizontal. 34.0 = Excavated area shall be barricaded off with red-& white tape. 35.0 = Proper slope of excavation shall be maintained. 36.0 = Proper sign board and illumination shall be maintained at excavated area. 37.0 = Wherever possible safety net shall be provided. 38.0 = Proper platform and hand rail has to be provided at the work place. 39.0 = All Electrical Equipments shall be earthed at two points. 40.0 = Temporary platform should be strong enough, have proper approach and hand rails. The above clauses are indicative only and not exhaustive. The other activities to maintain strong HSE conditions at site which may be beyond the above list of guidelines shall have to be done by the Bidder.
23.0	Other Points
23.1	The Bidder shall have to observe all work quality, safety regulations, general technical guide lines as stipulated in relevant clauses tender specification.
23.2	The Bidder shall send power of attorney, who shall sign the measurement books, bills, material receipt & other vouchers connected with this contract.
23.3	All other terms and conditions as stipulated in the tender document as well as in above mentioned references shall be applicable to this contract.
23.4	The Bidder need to submit The Bidder unqualified acceptance to the WO, once awarded the Contract being L1, within 10 (ten) days from the issue date of the WO.

for BHARAT HEAVY ELECTRICALS LTD.

Siddhartha Chakraborty
Engineer/Electrical (CMG)/ Maitree Site

All the bidders are requested to note that all the errata / technical clarifications / corrigendum / extension etc. shall be published in website www.bhel.com only. As such, all the bidders are requested to be in continuous touch with the website after this NIT is published.

Agency	Contact details	
BHEL – PSER, MAITREE SITE	Address	Bharat Heavy Electricals Ltd., Power Sector Easter Region, 2x660 MW Maitree Super Thermal Power Project, Upazilla: Rampal, Dist: Bagerhat, Division: Khulna, Bangladesh, Pin code: 9340
	Phone no.	+8801730593232 (WhatsApp: +919800172596)
	E-mail ID	siddhartha.chakraborty@bhel.in

Enclosures:

01. Notice Inviting Tender with Terms & Conditions
02. ANNEXURE – I: Pre-Qualification Criteria.
03. ANNEXURE – II: No Deviation Certificate
04. ANNEXURE – III: Format for Seeking Clarification
05. VOLUME – I: General Conditions of Contract
06. VOLUME – II: Price Schedule



BHARAT HEAVY ELECTRICALS LIMITED

(A Govt. of India Undertaking)
2x660 MW MAITREE STPP
RAMPAL, BAGERHAT, BANGLADESH

TENDER No:- MSTPP:ELECT:CONSTPOWER:O&M_TENDER/05-2022/001/T1

Date: 05/06/2022

ANNEXURE - I

PRE QUALIFICATION CRITERIA	
JOB	OPERATION & MAINTENANCE (O&M) OF THE CONSTRUCTION POWER NETWORK FOR A PERIOD OF 12 MONTHS WEF 01/07/2022 TO 30/06/2023 AT 2X660 MW, MSTPP, RAMPAL, BAGERHAT, BANGLADESH
TENDER NO	MSTPP:ELECT:CONSTPOWER:O&M_TENDER/05-2022/001/T1, DATE: 05/06/2022
SL NO	CRITERIA
1.0	FINANCIAL CRITERIA (a) BIDDER SHOULD HAVE AVERAGE MINIMUM ANNUAL FINANCIAL TURNOVER OF BDT 12,60,000.00 OR EQUIVALENT AMOUNT DURING THE LAST 3 (THREE) YEARS, ENDING ON 30-06-2021 OR CORRESPONDING FINANCIAL YEAR FOLLOWED BY THE BIDDER AND HAVING POSITIVE NET WORTH AS ON LATEST AUDITED ACCOUNTS. (b) BIDDER MUST HAVE EARNED PROFIT IN ANY ONE OF THE LAST THREE FINANCIAL YEARS ENDING ON 30-06-2021 OR CORRESPONDING FINANCIAL YEAR FOLLOWED BY THE BIDDER. AUDITED BALANCE SHEET AND PROFIT & LOSS ACCOUNT OF THE COMPANY FOR LAST 3 (THREE) FINANCIAL YEARS, ENDING ON 30-06-2021 OR CORRESPONDING FINANCIAL YEAR FOLLOWED BY THE BIDDER NEED TO BE SUBMITTED IN SUPPORT OF ABOVE. (c) IN CASE AUDITED BALANCE SHEET AND PROFIT AND LOSS ACCOUNT HAS NOT BEEN SUBMITTED FOR ALL THREE YEARS INDICATED ABOVE THEN THE APPLICABLE FINANCIAL AUDITED STATEMENTS SUBMITTED BY THE BIDDERS AGAINST THE REQUISITE THREE YEARS WILL BE AVERAGED FOR THREE YEARS (d) IF FINANCIAL STATEMENTS ARE NOT REQUIRED TO BE AUDITED STATUTORILY, THEN INSTEAD OF AUDITED FINANCIAL STATEMENTS, FINANCIAL STATEMENTS ARE REQUIRED TO BE CERTIFIED BY CHARTERED ACCOUNTANT.
2.0	TECHNICAL CRITERIA (a) BIDDER SHOULD HAVE EXPERIENCE IN SUB STATION MAINTENANCE IN POWER PROJECT OR IN INDUSTRIES ALONGWITH MAINTENANCE JOB IN 11KV HIGHT TENSION LINES WITHIN 10 YEARS FROM THE DATE OF BID SUBMISSION. (b) RELEVANT DOCUMENT IN SUPPORT OF ABOVE SHALL BE SUBMITTED.
3.0	GENERAL CRITERIA (a) BIDDERS MUST HAVE TRADE LICENSE (b) BIDDERS MUST HAVE TIN REGISTRATION CERTIFICATE (c) BIDDERS MUST HAVE BIN REGISTRATION CERTIFICATE
4.0	NOTES (a) THE VENDOR SHOULD HAVE ACHIEVED THE CRITERIA SPECIFIED IN THE PRE-QUALIFICATION CRITERIA, EVEN IF THE CONTRACT HAS NOT BEEN COMPLETED OR CLOSED. (b) AFTER SATISFACTORY FULFILLMENT OF ALL ABOVE CRITERIA, OFFER SHALL BE CONSIDERED FOR FURTHER EVALUATION & PARTICIPATION IN <u>PRICE BID</u> OPENING AS PER NIT & ALL OTHER TERMS OF TENDER. (c) BIDDERS QUOTING IN BANGLADESHI CURRENCY (BDT) ONLY SHALL BE QUALIFIED. (d) BIDDER MUST NOT BE UNDER BANKRUPTCY CODE PROCEEDINGS BY COMPTETENT AUTHORITY OF BANGLADESH WHICH WILL RENDER HIM INELIGIBLE FOR PARTICIPATION IN THIS TENDER, AND SHALL SUBMIT UNDERTAKING TO THIS EFFECT.

**BHARAT HEAVY ELECTRICALS LIMITED**

(A Govt. of India Undertaking)
2x660 MW MAITREE STPP
RAMPAL, BAGERHAT, BANGLADESH

TENDER No:- MSTPP:ELECT:CONSTPOWER:O&M_TENDER/05-2022/001/T1**Date: 05/06/2022**

**FORMAT TO BE FILLED-IN & SUBMITTED BY BIDDER ALONGWITH DOCUMENTS OF
PRE-QUALIFICATION CRITERIA**

NAME OF BIDDER	
MOBILE / TELEPHONE NO.	
Name of Partners / Directors	
Bidder Type : Indian/ Foreign*	
City*	
District & State*	
Country*	
Postal Code*	
Trade License No*	
TIN Number*	
BIN Number	
Company's Establishment Year	
Company's Nature of Business*	
Company's Legal Status*{limited company/ undertaking/joint venture/partnership/other}	
Company Category* {micro unit as per MSME/small unit as per MSME/medium unit as per MSME/Ancillary unit/project affected person of this company/ssi/ other}	
Enter Company's Contact Person Details (i) Title (Mr. / Mrs. / Ms. / Dr. / Shri)*	
(ii) Contact Name*	
(iii) Date Of Birth*	
(iv) Correspondence Email*	
(v) Designation	

SIGNATURE OF THE BIDDER WITH DATE & SEAL

पावर सेक्टर पूर्वी क्षेत्र (मुख्यालय) POWER SECTOR EASTERN REGION, DJ-9/1, SALLAKECITY, KOLKATA - 700 091 फैक्स/Fax:(033) 23211960 फ़ोन/Phone:बोर्ड/EPABX: 23398220	Page-17 of 31
---	---------------

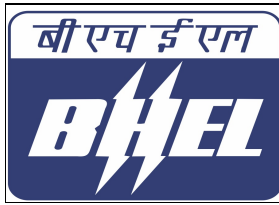

BHARAT HEAVY ELECTRICALS LIMITED

(A Govt. of India Undertaking)
2x660 MW MAITREE STPP
RAMPAL, BAGERHAT, BANGLADESH

TENDER No:- MSTPP:ELECT:CONSTPOWER:O&M_TENDER/05-2022/001/T1

Date: 05/06/2022

ANNEXURE – II

NO DEVIATION CERTIFICATE

(TO BE SUBMITTED IN BIDDER'S LETTERHEAD ONLY)

To
Bharat Heavy Electricals Ltd.,
Power Sector Easter Region,
2X660 MW Maitree Super Thermal Power Project,
Upazilla: Rampal, Dist: Bagerhat,
Division: Khulna, Bangladesh, Pin code: 9340

Sub	<u>NO DEVIATION CERTIFICATE</u>	
Job	OPEN TENDER FOR OPERATION & MAINTENANCE (O&M) OF THE CONSTRUCTION POWER NETWORK FOR A PERIOD OF 12 MONTHS WEF 01/07/2022 TO 30/06/2023 AT 2X660 MW, MSTPP, RAMPAL, BAGERHAT, BANGLADESH	
Ref	1.0	TENDER NUMBER - MSTPP:ELECT:CONSTPOWER:O&M_TENDER/05-2022/001/T1, Date: 05/06/2022
	2.0	Other references (if any).

Dear Sir,

With reference to above tender, this is to confirm you that we have gone through each and every term and condition mentioned in the enquiry (Terms and Conditions) and we offer our unqualified acceptance of the same. This is also to confirm that as per tender conditions, we have visited site before submission of our offer and noted the job content & site conditions etc.

We also confirm that we have not changed/modified the tender documents as appeared in BHEL website (<https://www.bhel.com/tenders>) and in case of observance at any stage; it shall be treated as null and void.

We hereby confirm that we have not taken any deviation from tender clauses together with other references as enumerated in the above referred NIT and we hereby convey our unqualified acceptance to all terms and conditions as stipulated in the tender and NIT. It is also confirmed that we've quoted the best price in the format received (**Price Schedule : Volume – II**) attached with the NIT.

Any deviation found subsequently at any time during execution of order shall be treated null and void.

Thanking you,
Yours faithfully,

(Signature, Date & Seal of Authorized Representative of the Bidder)



BHARAT HEAVY ELECTRICALS LIMITED

(A Govt. of India Undertaking)
2x660 MW MAITREE STPP
RAMPAL, BAGERHAT, BANGLADESH

TENDER No:- MSTPP:ELECT:CONSTPOWER:O&M_TENDER/05-2022/001/T1

Date: 05/06/2022

VOLUME – I
GENERAL CONDITIONS OF CONTRACT

Open Tender
Operation & Maintenance (O&M) of the
Construction Power Network for a period of 12
Months wef 01/07/2022 to 30/06/2023 at 2X660
MW, MSTPP, Rampal, Bagerhat, Bangladesh

BHARAT HEAVY ELECTRICALS LIMITED
(A GOVT. OF INDIA UNDERTAKING)
POWER SECTOR – EASTERN REGION
2 X 660 MW MSTPP, Rampal, Bagerhat, Bangladesh



BHARAT HEAVY ELECTRICALS LIMITED

(A Govt. of India Undertaking)
2x660 MW MAITREE STPP
RAMPAL, BAGERHAT, BANGLADESH

TENDER No:- MSTPP:ELECT:CONSTPOWER:O&M_TENDER/05-2022/001/T1

Date: 05/06/2022

GENERAL CONDITIONS OF CONTRACT (GCC) :: (Volume – I)

SL	BHEL STANDARD TERMS	Bidder's Confirmation (Accepted/Not Accepted)	Bidder's Deviation, if any (furnish details)
1.	<p>Our requirement is for use at 2X660 MW Maitree Super Thermal Power Project, Rampal, Bangladesh. Techno-Commercial Bid shall be opened first & afterwards price bid shall be opened for qualified bidder(s), who have qualified in PQ in Techno-Commercial Bids. Tenders will be received up to 15.00 Hours on the said due date. If the vendor submits offer i.e. Techno-Commercial Bid & Price Bid together in single attachment, the offer shall be liable for rejection. Price should be submitted as per tender format only. Note: In order to maintain sanctity of the tender system, it is advised that one Agent cannot represent two suppliers or quote on their behalf in a particular tender. In the tender, either one agent on behalf of the principal/OEM or Principal/OEM itself can bid but both cannot bid simultaneously for same item/product.</p>		
2.	<p>If any vendor sought to quote through their agents "They have to inform to BHEL in advance, before opening date. Otherwise, the offer will be treated as Unsolicited Offer and same will not be opened".</p>		
3.	<p>BHEL keeps its right to reject / load any offer which is having deviations to BHEL Specifications, Standard Terms & Conditions. All the bidders shall submit their offers only by filling the original BHEL tender documents. No other offer will be entertained. In case of Technical-Cum-Commercial bid, copy of the price bid has to be used to indicate commercial terms without price.</p>		
4.	<p>PAYMENT TERMS</p> <p>(a) The Price for Operation & Maintenance will be paid in each month (Total = 12 months) as certified by BHEL Engineer.</p> <p>(b) Bidder shall submit the Bidder's Running Account Bill, signed by Bidder's appointed Power of Attorney, once in a month at the end of each month. The RA Bill complete in all respect, accompanied by BHEL Engineer's Certified Measurement Sheets, jointly signed, will be paid, subject to completeness and correctness. Income Tax and VAT at the prevailing rates on gross value of work done & applicable surcharge shall be deducted from The Bidder bill, unless exempted by the Income Tax Authority.</p> <p>(c) 100% net payment shall be released on satisfactory completion of job as certified by site authority, through BEFTN/Cheque to the Bank account, as provided by the L1 Bidder after finalization of Tendering process within 30 days from the date of submission of Bidder's Running Account Bill to BHEL Office, Maitree STPP</p> <p>(d) 5% will be retained from each bill which will be released on completion of Operation & Maintenance period in all respect as certified by site authority.</p> <p>(e) Payment shall be made in Bangladesh Taka.</p> <p>(f) The accepted rate of individual items shall remain Firm throughout the contract period including extension period, if any without any escalation.</p> <p>(g) The Bidder should have valid VAT Registration Number and 12 digit TIN Number in Bangladesh</p>		



BHARAT HEAVY ELECTRICALS LIMITED

(A Govt. of India Undertaking)
2x660 MW MAITREE STPP
 RAMPAL, BAGERHAT, BANGLADESH

TENDER No:- MSTPP:ELECT:CONSTPOWER:O&M_TENDER/05-2022/001/T1

Date: 05/06/2022

	<p>and the same is to be furnished during submission of Bills</p> <p>(h) The quotation should be valid at least for a period of SIX (06) MONTHS from the tender due date of submission (extended, if any).</p> <p>(i) Price Variation Clause (PVC) / Over Run Compensation (ORC) / Rate Revision are not applicable in this Tender.</p>		
5.	<p>FORCE MAJEURE: The vendor shall be subject to force majeure clause defined as under: This force majeure is herein defined as any cause which is beyond the control of the tenderer which they would not have foreseen or with a reasonable amount of diligence could not have foreseen and which subsequently affect the performance of the contract such as SRCC (strike riot and civil commotion), earthquake, flood, acts of God, acts of any government, domestic or foreign including but not limited to war. The tenderer shall not be liable for delay in performing his obligation resulting from any force majeure clause as referred to and/or defined above. The date of completion will be subject to hereinafter provided be extended by a reasonable time even though such cause may occur after tenderer's performance of his obligation has been delayed for other causes.</p>		
6.	<p>ARBITRATION & CONCILIATION</p>		
	<p>ARBITRATION:</p>		
A	<p>Except as provided elsewhere in this Contract, in case Parties are unable to reach amicable settlement (whether by Conciliation to be conducted as provided in Clause 17.2 herein below or otherwise) in respect of any dispute or difference; arising out of the formation, breach, termination, validity or execution of the Contract; or, the respective rights and liabilities of the Parties; or, in relation to interpretation of any provision of the Contract; or, in any manner touching upon the Contract (hereinafter referred to as the 'Dispute'), then, either Party may, commence arbitration in respect of such Dispute by issuance of a notice in terms of section 21 of the Arbitration & Conciliation Act, 1996 (hereinafter referred to as the 'Notice'). The Notice shall contain the particulars of all claims to be referred to arbitration in sufficient detail and shall also indicate the monetary amount of such claim. The arbitration shall be conducted by a sole arbitrator to be appointed by the Head of the BHEL Power Sector Region issuing the Contract within 60 days of receipt of the complete Notice. The language of arbitration shall be English.</p> <p>The Arbitrator shall pass a reasoned award.</p> <p>Subject as aforesaid, the provisions of Arbitration and Conciliation Act 1996 (India) or statutory modifications or re-enactments thereof and the rules made thereunder as in force from time to time shall apply to the arbitration proceedings under this clause. The seat of arbitration shall be Kolkata (the place from where the contract is Issued). The Contract shall be governed by and be construed as per provisions of the laws of India. Subject to this provision 17.1.1 regarding ARBITRATION, the principal civil court exercising ordinary civil jurisdiction over the area where the seat of arbitration is located shall have exclusive jurisdiction over any DISPUTE to the exclusion of any other court.</p>		
B	<p>In case of Contract with Public Sector Enterprise (PSE) or a Government Department, the following shall be applicable: In the event of any dispute or difference relating to the interpretation and application of the provisions of commercial contract(s) between Central Public Sector Enterprises (CPSEs)/ Port Trusts inter se and also between CPSEs and Government Departments/Organizations (excluding disputes concerning Railways, Income Tax, Customs & Excise Departments), such dispute or difference shall be taken up by either party for resolution through AMRCD (Administrative Mechanism for Resolution of CPSEs Disputes) as mentioned in DPE OM No. 4(1)/2013-DPE(GM)/FTS-1835 dated 22-05-2018 as amended from time to time.</p>		



BHARAT HEAVY ELECTRICALS LIMITED

(A Govt. of India Undertaking)
2x660 MW MAITREE STPP
 RAMPAL, BAGERHAT, BANGLADESH

TENDER No:- MSTPP:ELECT:CONSTPOWER:O&M_TENDER/05-2022/001/T1

Date: 05/06/2022

C	The cost of arbitration shall initially be borne equally by the Parties subject to the final allocation thereof as per the award/order passed by the Arbitrator.		
D	Notwithstanding the existence of any dispute or differences and/or reference for the arbitration, the Contractor shall proceed with and continue without hindrance the performance of its obligations under this Contract with due diligence and expedition in a professional manner unless the dispute inter-alia relates to cancellation, termination or short-closure of the Contract by BHEL.		
	CONCILIATION:		
A	<p>If at any time (whether before, during or after the arbitral or judicial proceedings), any Disputes (which term shall mean and include any dispute, difference, question or disagreement arising in connection with construction, meaning, operation effect, interpretation or breach of the agreement, contract), which the Parties are unable to settle mutually, arise inter-se the Parties, the same may, be referred by either party to Conciliation to be conducted through Independent Experts Committee (IEC) to be appointed by competent authority of BHEL from the BHEL Panel of Conciliators.</p> <p>Notes:</p> <ol style="list-style-type: none"> 1. No serving or a retired employee of BHEL/Administrative Ministry of BHEL shall be included in the BHEL Panel of Conciliators. 2. Any other person(s) can be appointed as Conciliator(s) who is/are mutually agreeable to both the parties from outside the BHEL Panel of Conciliators. <p>The proceedings of Conciliation shall broadly be governed by Part-III of the Arbitration and Conciliation Act 1996 or any statutory modification thereof and as provided in Procedure 2.3 to this GCC (as available in www.bhel.com). The Procedure 2.3 together with its Formats (as available in www.bhel.com) will be treated as if the same is part and parcel hereof and shall be as effectual as if set out herein in this GCC.</p> <p>The Contractor hereby agrees that BHEL may make any amendments or modifications to the provisions stipulated in the Procedure 2.3 (as available in www.bhel.com) to this GCC from time to time and confirms that it shall be bound by such amended or modified provisions of the Procedure 2.3 (as available in www.bhel.com) with effect from the date as intimated by BHEL to it.</p>		
B	<p>No Interest payable to Contractor</p> <p>Notwithstanding anything to the contrary contained in any other document comprising in the Contract, no interest shall be payable by BHEL to Contractor on any moneys or balances including but not limited to the Security Deposit, EMD, Retention Money, RA Bills or the Final Bill, or any amount withheld and/or appropriated by BHEL etc., which becomes or as the case may be, is adjudged to be due from BHEL to Contractor whether under the Contract or otherwise.</p>		
C	<p>JURISDICTION:</p> <p>All disputes or differences arising under out of or in connection with the purchase order shall be subject to the exclusive jurisdiction of court at Kolkata.</p>		
7	<p>RIGHTS OF BHEL:</p> <p>(A) To withdraw any portion of work/supply and/or to restrict / alter the quantum of work/supply as indicated in the contract during the progress of work/supply and get it done through other agency and/or to suit BHEL's commitment to its customer or in case BHEL decides to advance the date of completion due to other emergency reasons / BHEL's obligation to its customer.</p> <p>(B) To terminate the contract or withdraw portion of work/supply and get it done through other agency, at the risk and cost of the contractor after due notice of a period of 14 days' by BHEL in any of the following cases:</p> <ol style="list-style-type: none"> i) Contractor/Supplier's poor progress of the work vis-à-vis execution timeline as stipulated in the Contract, backlog attributable to contractor/supplier including unexecuted portion of work/supply does not appear to be executable within balance available (#) period considering its performance of execution. ii) Withdrawal from or abandonment of the work by contractor before completion of the work as per contract. 		

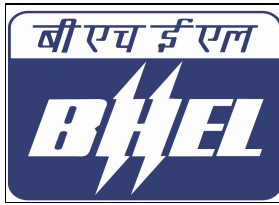

BHARAT HEAVY ELECTRICALS LIMITED

(A Govt. of India Undertaking)
2x660 MW MAITREE STPP
RAMPAL, BAGERHAT, BANGLADESH

TENDER No:- MSTPP:ELECT:CONSTPOWER:O&M_TENDER/05-2022/001/T1

Date: 05/06/2022

- iii) Non-completion of work/Non-supply by the Contractor / Supplier within scheduled completion/delivery period as per Contract or as extended from time to time, for the reasons attributable to the contractor/supplier.
- iv) Termination of Contract on account of any other reason (s) attributable to Contractor/Supplier.
- v) Assignment, transfer, subletting of Contract without BHEL's written permission resulting in termination of contract or part thereof by BHEL.
- vi) Non-compliance to any contractual condition or any other default attributable to Contractor/ Supplier. In-case inputs from BHEL/Customer are likely to be delayed or are actually delayed, this delay may also be taken into account while considering balance period available for execution of Contract.

(C) Risk & Cost Amount against Balance Work:

Risk & Cost amount against balance work shall be calculated as follows:

Risk & Cost Amount= [(A-B) + (A x H/100)], Where,

A= Value of Balance scope of Work/Supply (*) as per rates of new contract

B= Value of Balance scope of Work/Supply (*) as per rates of old contract being paid to the contractor / supplier at the time of termination of contract i.e. inclusive of PVC & ORC, if any.

H = Overhead Factor to be taken as 5

In case (A-B) is less than 0 (zero), value of (A-B) shall be taken as 0 (zero).

(*) Balance scope of work / supply (in case of termination of contract):

Difference of Contract Quantities and Executed Quantities as on the date of issue of Letter for 'Termination of Contract', shall be taken as balance scope of Work / Supply for calculating risk & cost amount. Contract quantities are the quantities as per original contract. If, Contract has been amended, quantities as per amended Contract shall be considered as Contract Quantities.

Items for which total quantities to be executed have exceeded the Contract Quantities based on drawings issued to contractor from time to time till issue of Termination letter, then for these items total Quantities as per issued drawings would be deemed to be contract quantities.

Substitute / extra items whose rates have already been approved would form part of contract quantities for this purpose. Substitute / extra items which have been executed but rates have not been approved, would also form part of contract quantities for this purpose and rates of such items shall be determined in line with contractual provisions.

However, increase in quantities on account of additional scope in new tender shall not be considered for this purpose.

NOTE: In-case portion of work is being withdrawn, contract quantities pertaining to portion of work withdrawn shall be considered as 'Balance scope of work / supply' for calculating Risk & Cost amount.

(D) LD against delay in executed work/ supply in case of Termination of Contract:

LD against delay in executed work / supply shall be calculate in line with LD clause as per GCC/SCC/TCC/Special note/any other annexure of tender document (in compliance with order of precedence), for the delay attributable to contractor / supplier. For this purpose, contract (Total Executable) value shall be taken value of work / supply for the purpose of limiting the maximum LD value.

Method for calculation of "LD against delay in executed work / supply" is given below:

i) Let the time period from scheduled date of start of work till termination of contract excluding the period of Hold (if any) not attributable to contractor / supplier = T1

ii) Let the value of executed work / supply till the time of termination of contract= X

iii) Let the Total Executable Value of work / supply for which inputs/fronts were made available to contractor / supplier and were planned for execution till termination of contract = Y

iv) Delay in executed work / supply attributable to contractor/supplier i.e. T2=[1-(X/Y)] x T1

v) LD shall be calculated in line with LD clause [as per GCC/SCC/TCC/Special note/any

पावर सेक्टर पूर्वी क्षेत्र (मुख्यालय)

POWER SECTOR EASTERN REGION, DJ-9/1, SALLAKECITY, KOLKATA - 700 091

फैक्स/Fax:(033) 23211960 फ़ोन/Phone:बोर्ड/EPABX: 23398220

Page-24 of 31



BHARAT HEAVY ELECTRICALS LIMITED

(A Govt. of India Undertaking)
2x660 MW MAITREE STPP
RAMPAL, BAGERHAT, BANGLADESH

TENDER No:- MSTPP:ELECT:CONSTPOWER:O&M_TENDER/05-2022/001/T1

Date: 05/06/2022

	<p>other annexure of tender document (in compliance with order of precedence)] of the Contract for the delay attributable to contractor / supplier taking "X" as Contract Value and "T2" as period of delay attributable to contractor/ supplier.</p> <p>(E) Recoveries arising out of Risk & Cost and LD or any other recoveries due from Contractor. Following sequence shall be applicable for recoveries from contractor / supplier on whom risk & cost has been invoked, after informing the contractor / supplier of the total proposed recovery:</p> <p>a) Dues available in the form of Bills payable to contractor / supplier, SD, BGs against the same contract.</p> <p>b) Demand notice for deposit of balance recovery amount shall be sent to contractor/ supplier, if funds are insufficient to effect complete recovery against dues indicated in (a) above.</p> <p>c) If contractor / supplier fails to deposit the balance amount to be recovered within the period as prescribed in demand notice, following action shall be taken for balance recovery:</p> <p>i) Dues payable to contractor / supplier against other contracts in the same Region / Unit shall be considered for recovery.</p> <p>ii) If recovery cannot be made out of dues payable to the contractor / supplier as above, balance amount to be recovered, shall be informed to other Regions/Units for making recovery from the Unpaid Bills/Running Bills/SD/BGs/Final Bills of contractor / supplier.</p> <p>iii) In-case recoveries are not possible with any of the above available options, Legal action shall be initiated for recovery against contractor / supplier.</p>		
8	LOADING FACTORS FOR DEVIATION TO BHEL STANDARD TERMS & CONDITIONS		
a	Bank Guarantee: Non submission of 10% BG (if applicable) will attract 10% loading on the offers.		
b	Penalty Clause: Non acceptance of penalty clause will attract maximum 10% loading on the offer and accordingly proportionate percentage will be loaded for accepting less percentage of penalty clause. Ex: If the supplier has accepted for maximum 5% penalty clause, then balance 5% will be loaded.		
c	For all other Terms & Conditions, if the offer is not confirming to the same, BHEL at its discretion shall load the same and the loading pattern shall be intimated to the bidders before price bid opening. However, BHEL reserves the right to cancel a bid in case of non-acceptance of any terms and conditions finally arrived before price bid opening.		
d	Note: The offers not complying the above Terms & Conditions will not be accepted.		

Note:

01. In case of any conflict / inconsistency in any clause of the tender or between various sections of the tender, bidder should bring the same in writing to BHEL for clarification before submission of the bid, failing which the most stringent interpretation of the clause in favor of BHEL shall be adopted and the same shall be binding to the bidder.
02. Any deviation sought by the bidder should be indicated in the techno-commercial bid.
03. **Bidder should write "accepted" in the column "Bidder's Confirmation (Accepted/Not Accepted)" for each clause, if the conditions are agreeable or else should write "not accepted" with the deviations sought in "Bidder's Deviation, if any (furnish details)" column. Kindly Note, Offers with deviation are liable for rejection**

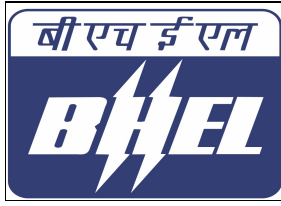

BHARAT HEAVY ELECTRICALS LIMITED

(A Govt. of India Undertaking)
2x660 MW MAITREE STPP
RAMPAL, BAGERHAT, BANGLADESH

TENDER No:- MSTPP:ELECT:CONSTPOWER:O&M_TENDER/05-2022/001/T1

Date: 05/06/2022

04. If any clause is left blank in the column of "Bidder's Confirmation (Accepted/Not Accepted)", it shall be presumed that the clause is accepted by the bidder.

SIGNATURE OF THE BIDDER WITH SEAL AND DATE



BHARAT HEAVY ELECTRICALS LIMITED

(A Govt. of India Undertaking)
2x660 MW MAITREE STPP
RAMPAL, BAGERHAT, BANGLADESH

TENDER No:- MSTPP:ELECT:CONSTPOWER:O&M_TENDER/05-2022/001/T1

Date: 05/06/2022

VOLUME – II
PRICE SCHEDULE OF CONTRACT

Open Tender
Operation & Maintenance (O&M) of the
Construction Power Network for a period of 12
Months wef 01/07/2022 to 30/06/2023 at 2X660
MW, MSTPP, Rampal, Bagerhat, Bangladesh

BHARAT HEAVY ELECTRICALS LIMITED
(A GOVT. OF INDIA UNDERTAKING)
POWER SECTOR – EASTERN REGION
2 X 660 MW MSTPP, Rampal, Bagerhat, Bangladesh



BHARAT HEAVY ELECTRICALS LIMITED

(A Govt. of India Undertaking)
2x660 MW MAITREE STPP
RAMPAL, BAGERHAT, BANGLADESH

TENDER No:- MSTPP:ELECT:CONSTPOWER:O&M_TENDER/05-2022/001/T1

Date: 05/06/2022

(A) PREAMBLE	
Clause No.	Descriptions
1.0	This preamble forms part of tender document and schedule of items. The Bidder should read this preamble carefully before filling in rates for various items. Clauses under this preamble shall be read in conjunction with Volume – I (as applicable as per NIT) and shall have precedence over any contrary statement mentioned any where in this document. The Bidder shall sign & stamp all the pages of the tender document as a token of their acceptance. Submission of unfilled formats with sign & stamp shall be construed as acceptance of the contents of the same.
2.0	The work shall be carried out strictly as per specifications, description of the items in these schedule and / or engineer's instructions. Drawings enclosed with the tender are only preliminary and for guidance/tender purposes giving some idea of the work involved. The work is to be executed as per terms & conditions of the tender and actual drawings/documents, which shall be furnished during execution.
3.0	Items of work provided in this schedule but not covered in this specification shall be executed strictly as per instruction of the engineer.
4.0	Unless specifically mentioned otherwise in the tender document, the Bidder shall quote for the finished items and shall provide for the complete cost towards power, fuel, tools, tackles, equipment, constructional plants, temporary works, labour, dismantling of all temporary piping, structures, valves, pumps, tanks & other misc. equipment, strengthening of roads/culverts/bridges etc. including arranging all clearances etc. required for carrying out different activities & tests, materials, levies, taxes (except service tax), transport, layout, repairs, rectification, maintenance till handing over, supervisions, colonies, shops, establishments, overheads, profits and all incidental items not specifically mentioned but reasonably implied and necessary to complete the work according to the complete tender document and this schedule.
5.0	The quantities of the various items mentioned in this schedule of items are approximate, based on very preliminary information and may vary to any extent or be deleted altogether. The quoted rates of each item will remain firm throughout the period of execution including extension, for reasons whatsoever, as long as variation in the total value of work executed under any part of this contract including extra items.
6.0	In case Sealed /Paper Price Bids are opened for finalization of the tender, possibility of variation of quantity/ addition/deletion of items can not be ruled out. Under such circumstances, after execution of work, if it is observed that standing as L-1 is changed based on actual quantity executed, the bidder shall give suitable rebate to maintain your standing as L-1. Since this aspect can be assessed at the end of execution, necessary adjustment will be effected at the end of execution in final bill. This condition shall not be applicable where the tender is finalised through Reverse Auction.
7.0	BHEL reserve the right to rationalize the rates, quoted by L-1 bidder against unit rate items and/ or other optional items with respect to item-wise lowest rates (amongst the participating bidders), before placement of order. The rates of unit rate/optional items shall remain valid till execution of the order, if the job is awarded to the bidder.
8.0	The rates quoted shall be inter alia including the following inclusive of AIT & VAT :- <ul style="list-style-type: none">• OVER HEAD CHARGE:<ul style="list-style-type: none">○ Accommodation for Manpower○ Safety Appliances for Individual & 11KV Network○ Required T&Ps○ Local Transportation for shifting 11 KV Materials/T&Ps across the Plant• MISCELLANEOUS CHARGE:<ul style="list-style-type: none">○ Insurance of Manpower○ Medical of Manpower○ Uniforms of Manpower○ Charges for Mobile Handsets and Monthly Mobile Bills• OTHER CHARGES:<ul style="list-style-type: none">○ Cleaning of site of any vegetation, dressing, clearing of old structures and levelling etc.○ Fixing of grid pillars, benchmarks etc. required for commencement of site activities



BHARAT HEAVY ELECTRICALS LIMITED

(A Govt. of India Undertaking)
2x660 MW MAITREE STPP
RAMPAL, BAGERHAT, BANGLADESH

TENDER No:- MSTPP:ELECT:CONSTPOWER:O&M_TENDER/05-2022/001/T1

Date: 05/06/2022

Special Note on Charges of Deduction on absence of Manpower	
	<p>(i) During absence/leave of any Manpower of the aforesaid list, equivalent alternative Manpower should have to be provided. If the Bidder fails to do so and the absence prevails for more than <u>one day</u>, BHEL reserves the right to deduct the cost of the Manpower in pro-rata basis (with an Overhead of 30%) from the RA Bills starting from the <u>2nd day of the absence</u> of that Manpower.</p> <p>Additionally there will be a Penalty of Liquidated damage (as per Point No. 18.0 of (B) Scope of Work with Terms & Conditions of NIT), which will be levied @ 0.25% of the contract price (O&M part of the Price schedule) for such non-functioning of each day or part thereof. The liability for delay shall not in any case exceed 5% (five percent) of the contract price, including taxes, duties (O&M part of the price schedule).</p> <p>(ii) Payment of all Manpower should be cleared for each month within the first 7 days of the next month & Wage Sheet should be submitted to BHEL along with RA Bills. If BHEL experiences any sort of Manpower crisis or delay in Jobs due to problems arising out of the Non-timely Payment to the Manpower or O&M Manpower report to BHEL regarding the Non-timely Payment of Wages, BHEL reserves the right to recover that Manpower Wages as per the available record of previous submitted Wage Sheet from the RA Bills & to pay directly to the O&M Manpower and in those cases, an Overhead charges @ 30% of the amount paid for those wages of manpower, will be levied from the Bidder.</p>
9.0	Rates shall be quoted in figures and in words in clear legible writing. No overwriting is allowed. All scoring and cancellations should be countersigned and in case of illegibility, the interpretation of engineer shall be final. All entries shall be in English language.
10.0	All works item wise shall be measured upon completion and paid for at the rates quoted and accepted as per BHEL approved payment schedule/billing break-up.
11.0	The Bidder shall be deemed to have visited site and made himself aware of all the site conditions, studied the specifications and details of work to be done within the time schedule attached and to have acquainted himself of the conditions prevailing at site before submission of his bid/offer. No claim whatsoever due to lack of knowledge of site conditions shall be entertained after award of the work.
12.0	No splitting of the job is envisaged unless the same is specifically indicated later by BHEL. Decision of BHEL in this regard shall be final and binding to the bidders.
13.0	Bidders are not allowed to alter the Price Schedule format including item description, quantity etc. and the offer is liable for rejection if the bidders submit their prices in Price Schedules modified by them. BHEL reserves the right to reject the offers of bidders who submit offers in Price Formats, which are modified/alterd by them. Also putting any comments instead of rates/price in the designated column of the rate schedule shall make the offer liable for rejection.
14.0	Engineer's decision shall be final and binding on the contractor regarding clarification of items in the schedule with respect to the other sections/volumes of the contract.
15.0	No PVC/ORC/Rate-Revision/Escalation is payable for the Contract.
16.0	No interest, whatsoever, shall be payable by BHEL on the security deposit, any bank guarantee submitted or any amount due to successful bidder/contractor. No idling charge whatsoever (either for labour or any other resources) is payable by BHEL for any reason whatsoever.
17.0	Specifications mentioned in the Price schedule are absolute & these shall not be taken into consideration for quoting/calculating amount in the rate schedule. These shall be utilized as per relevant sections of tender. Bidders shall quote for each item in the rate column, taking unit as mentioned in the quantity column. Rates shall be filled in both figures and words. Amount shall be calculated based upon these rates multiplied by the mentioned quantity for the respective items.
18.0	Bidder's Grand Total price shall be considered for evaluation unless stated otherwise.
19.0	Terms of Payment – For Terms of Payment of Successful Bidder's RA Bills etc. strictly refer Point No. 6.0 of (B) Scope of Work with Terms & Conditions of NIT.

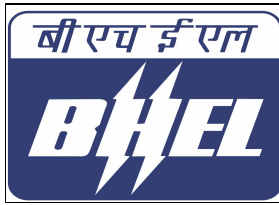
**BHARAT HEAVY ELECTRICALS LIMITED**

(A Govt. of India Undertaking)
2x660 MW MAITREE STPP
RAMPAL, BAGERHAT, BANGLADESH

TENDER No:- MSTPP:ELECT:CONSTPOWER:O&M_TENDER/05-2022/001/T1**Date: 05/06/2022****(B) PRICE SCHEDULE, REV-0****TENDER NO - MSTPP:ELECT:CONSTPOWER:O&M_TENDER/05-2022/001/T1, DATE: 05/06/2022****TENDER SUBJECT - OPERATION & MAINTENANCE (O&M) OF THE CONSTRUCTION POWER NETWORK FOR A PERIOD OF 12 MONTHS WEF 01/07/2022 TO 30/06/2023 AT 2X660 MW, MSTPP, RAMPAL, BAGERHAT, BANGLADESH**

SI No.	DESCRIPTION	QUANTITY	UNIT RATE (IN BDT)	COST FOR 1 MONTH (IN BDT)	COST FOR 12 MONTHS (IN BDT)	TOTAL COST (IN BDT)
(A)	(B)	(C)	(D)	(E) = (C) X (D)	(F) = (E) X 12	(G) = SUM OF ALL (F)
01	SALARY FOR DIPLOMA ENGINEER [SHOULD HAVE MINIMUM 5 YEARS OF EXPERIENCE]	01				
02	SALARY FOR ELECTRICIAN	03				
03	SALARY FOR ASSISTANT ELECTRICIAN	03				

TOTAL COST IN WORDS INCLUSIVE OF AIT & VAT :-

BDT _____

NOTE TO BIDDERS:

01. NO OVERWRITING IS ALLOWED IN THIS FORMAT.
02. PRICE SHOULD BE MENTIONED HERE ONLY AND NOWHERE ELSE IN THE TENDER DOCUMENTS.
03. NO ADDITIONAL DOCUMENTS SHOULD BE ATTACHED WITH THIS FORMAT AS SUPPORTING.
04. BIDDERS MUST NOTE THAT WHILE QUOTING RATES FOR ABOVE PARTICULARS, REFERENCE MUST BE DRAWN IN LINE WITH POINT NO. 8.0 OF THE PREAMBLE OF PRICE SCHEDULE (VOL - II), AS MENTIONED BEFORE.

Signature with DateName & Designation of Bidder



BHARAT HEAVY ELECTRICALS LIMITED

(A Govt. of India Undertaking)
2x660 MW MAITREE STPP
RAMPAL, BAGERHAT, BANGLADESH

TENDER No:- MSTPP:ELECT:CONSTPOWER:O&M_TENDER/05-2022/001/T1

Date: 05/06/2022

The End of Documents

पावर सेक्टर पूर्वी क्षेत्र (मुख्यालय)

POWER SECTOR EASTERN REGION, DJ-9/1, SALLAKECITY, KOLKATA - 700 091

फैक्स/Fax:(033) 23211960 फ़ोन/Phone:बोर्ड/EPABX: 23398220

Page-31 of 31