



Bharat Heavy Electricals Limited
Industrial Valves Plant
Goindwal Sahib (Punjab)

Enquiry No.
2425-005E

Date:
18.04.2024

NOTICE INVITING TENDER (NIT)

BHEL Goindwal Sahib (Punjab) invites offers from interested bidders / suppliers for submission of their offer through e-procurement mode at <https://eprocurebhel.co.in/>. Offers in any other mode will not be accepted. In case of any difficulty faced while registering on BHEL's e-Procurement portal developed by NIC, queries may be addressed to 0120-4001002, 0120-4001005 and 0120-6277787; email: support-eproc@nic.in. These details are also available on 'Contact Us' page of the portal.

Tender enquiry no. & date	2425-005E dated 18.04.2024
Form of contract	Supply
Tender / Item description	Rate Contract for procurement of HSFSG Fasteners
Material standard / Drawings	As per attached Specifications & Drawings
Location(s) of Supply / Work (5 Projects Sites)	NTPC Talcher, Angul, Odisha
	NTPC Lara, Pussore, Chappora, Chhattisgarh
	Talabira, Village Talabira, Sambalpur, Odisha
	Yamunanagar, Haryana
Earnest Money Deposit (EMD)	Not Applicable
Performance Security (PS)	Rs 2.0 lakhs, valid for a period of 41 months. To submit within 21 days from the date of placement of first purchase order under RC. (Refer Sr. no. S21 of Special Terms)
Quotation parts	Two Part Bid
Tender download / Bid submission start date	18.04.2024 (17:00 Hrs. IST)
Tender download / Bid submission end date	30.04.2024 (12:00 Hrs. IST)
Tender / Bid opening date	30.04.2024 (15:30 Hrs. IST)
Validity of offer	Bids shall be valid for tender finalization till 30 th Jun'24
Validity of Contract	18 months
Reverse auction	Applicable
Integrity pact (IP)	Applicable
Contact person details	Sumeet Bansal, DGM / MM 01859-224 628, sbansal@bhel.in
	Pranshu, Manager / MM 01859-224 685, pranshu@bhel.in



SPECIAL TERMS AND CONDITIONS
 (Tender enquiry no. 2425-005E dated 18.04.2024 **Due date 30.04.2024**)
ITEM: HSFG Fasteners [Rate Contract]

S1 SCOPE OF SUPPLY

Material shall be supplied as per the applicable Specifications / Drawings as mentioned in the Table – 1. National & International material standards shall have to be arranged by bidders themselves.

Table 1 : List of Items along with Tender Quantity, Drawing Number and Delivery Destination

Sr. No.	Material Code	Material Description	Tender Quantity	Unit of Measurement	Drawing / BPS of Bolts and Nuts	Applicable TDC	Delivery Destination
1	412371606000-ODA	BOLT-M16x60 -8.8-IS1364P1	15,660	SET	BPS 41237	TDC:5:211 Rev 02	Talcher 2x660MW, Angul, Odisha
2	413200001600-ODA	NUT -M16 -CL8-IS1364P3	15,660		BPS 41320	TDC:5:211 Rev 02	
3	412371609000-ODA	BOLT-M16x90 -8.8-IS1364P1	10,550	SET	BPS 41237	TDC:5:211 Rev 02	
4	413200001600-ODA (same sr. no. 2)	NUT -M16 -CL8-IS1364P3	10,550		BPS 41320	TDC:5:211 Rev 02	
5	414190001600-ODA	M16 WASHER Grade 10.9	26,210	Number	--	TDC:5:211 Rev 02	
6	414190002000-ODA	M20 WASHER Grade 10.9	2,49,140	Number	--	TDC:5:211 Rev 02	
7	412412013001-ODA	M20X130 EXTENDED HSFG BOLTS&NUTS GR.8.8	2,110	Number	3-35-700-09998 Rev 00	TDC:5:215 Rev 01	
8	412412016001-ODA	M20X160 EXTENDED HSFG BOLTS&NUTS GR.8.8	2,438	Number	3-35-700-09998 Rev 00	TDC:5:215 Rev 01	
9	412412006001-ODA	M20X60 EXTENDED HSFG BOLTS&NUTS GR.8.8	1,74,711	Number	3-35-700-09998 Rev 00	TDC:5:215 Rev 01	
10	412412009001-ODA	M20X90 EXTENDED HSFG BOLTS&NUTS GR.8.8	69,881	Number	3-35-700-09998 Rev 00	TDC:5:215 Rev 01	
11	414180002400-ODA	M24 WASHER Grade 8.8	5,56,568	Number	--	TDC:5:211 Rev 02	
12	412400030000-ODA	M24x130 EXTENDEDHSFG BOLTS&NUTS Grade8.8	36,228	Number	3-35-700-06802 Rev 06	TDC:5:215 Rev 01	



SPECIAL TERMS AND CONDITIONS

(Tender enquiry no. 2425-005E dated 18.04.2024 **Due date 30.04.2024**)

ITEM: HSFG Fasteners [Rate Contract]

Sr. No.	Material Code	Material Description	Tender Quantity	Unit of Measurement	Drawing / BPS of Bolts and Nuts	Applicable TDC	Delivery Destination
13	412400040000-ODA	M24x170 EXTENDED HSFG BOLT &NUT Grade8.8	2,672	Number	3-35-700-06802 Rev 06	TDC:5:215 Rev 01	Talcher 2x660MW, Angul, Odisha
14	412400050000-ODA	M24X200 EXTENDED HSFG BOLT &NUT GRADE8.8	632	Number	3-35-700-06802 Rev 06	TDC:5:215 Rev 01	
15	412400010000-ODA	M24x70 EXTENDED HSFG BOLTS&NUTS Grade8.8	3,96,836	Number	3-35-700-06802 Rev 06	TDC:5:215 Rev 01	
16	412400020000-ODA	M24x90 EXTENDED HSFG BOLTS&NUTS Grade8.8	1,20,200	Number	3-35-700-06802 Rev 06	TDC:5:215 Rev 01	
17	414190003000-ODA	M30 WASHER Grade 10.9	1,21,450	Number	--	TDC:5:211 Rev 02	
18	412403013001-ODA	M30X130 EXTENDED HSFG BOLTS&NUTS GR.10.9	22,975	Number	3-35-700-09999 Rev 00	TDC:5:215 Rev 01	
19	412403017001-ODA	M30X170 EXTENDED HSFG BOLTS&NUTS GR.10.9	13,352	Number	3-35-700-09999 Rev 00	TDC:5:215 Rev 01	
20	412403020001-ODA	M30X200 EXTENDED HSFG BOLTS&NUTS GR.10.9	2,540	Number	3-35-700-09999 Rev 00	TDC:5:215 Rev 01	
21	412403009001-ODA	M30X90 EXTENDED HSFG BOLTS&NUTS GR.10.9	21,858	Number	3-35-700-09999 Rev 00	TDC:5:215 Rev 01	
22	414190003600-ODA	M36 WASHER Grade 10.9	4,27,942	Number	--	TDC:5:211 Rev 02	
23	412413610001-ODA	M36X100 EXTENDED HSFG BOLT&NUT GR.10.9	70,144	Number	0-86-700-A0323 Rev 00	TDC:5:215 Rev 01	
24	412413612001-ODA	M36X120 EXTENDED HSFG BOLT&NUT GR.10.9	49,095	Number	0-86-700-A0323 Rev 00	TDC:5:215 Rev 01	
25	412413614001-ODA	M36X140 EXTENDED HSFG BOLT&NUT GR.10.9	66,793	Number	0-86-700-A0323 Rev 00	TDC:5:215 Rev 01	

SPECIAL TERMS AND CONDITIONS

(Tender enquiry no. 2425-005E dated 18.04.2024 **Due date 30.04.2024**)

ITEM: HSFG Fasteners [Rate Contract]

Sr. No.	Material Code	Material Description	Tender Quantity	Unit of Measurement	Drawing / BPS of Bolts and Nuts	Applicable TDC	Delivery Destination
26	412413616001-ODA	M36X160 EXTENDED HSFG BOLT&NUT GR.10.9	18,439	Number	0-86-700-A0323 Rev 00	TDC:5:215 Rev 01	Talcher 2x660MW, Angul, Odisha
27	412413619001-ODA	M36X190 EXTENDED HSFG BOLT&NUT GR.10.9	9,500	Number	0-86-700-A0323 Rev 00	TDC:5:215 Rev 01	
28	412371606000-CHH	BOLT-M16x60 -8.8-IS1364P1	40	SET	BPS 41237	TDC:5:211 Rev 02	Lara 2x800MW, Chhattisgarh
29	413200001600-CHH	NUT -M16 -CL8-IS1364P3	40		BPS 41320	TDC:5:211 Rev 02	
30	412371609000-CHH	BOLT-M16x90 -8.8-IS1364P1	7,060	SET	BPS 41237	TDC:5:211 Rev 02	
31	413200001600-CHH (same as Sr. no. 29)	NUT -M16 -CL8-IS1364P3	7,060		BPS 41320	TDC:5:211 Rev 02	
32	414190001600-CHH	M16 WASHER Grade 10.9	7,460	Number	--	TDC:5:211 Rev 02	
33	414190002000-CHH	M20 WASHER Grade 10.9	72,902	Number	--	TDC:5:211 Rev 02	
34	412412006001-CHH	M20X60 EXTENDED HSFG BOLTS&NUTS GR.8.8	42,788	Number	3-35-700-09998 Rev 00	TDC:5:215 Rev 01	
35	412412009001-CHH	M20X90 EXTENDED HSFG BOLTS&NUTS GR.8.8	32,132	Number	3-35-700-09998 Rev 00	TDC:5:215 Rev 01	
36	414180002400-CHH	M24 WASHER Grade 8.8	6,27,892	Number	--	TDC:5:211 Rev 02	
37	412400030000-CHH	M24x130 EXTENDEDHSFG BOLTS&NUTS Grade8.8	84,394	Number	3-35-700-06802 Rev 06	TDC:5:215 Rev 01	
38	412400040000-CHH	M24x170 EXTENDED HSFG BOLT &NUT Grade8.8	10,074	Number	3-35-700-06802 Rev 06	TDC:5:215 Rev 01	



SPECIAL TERMS AND CONDITIONS

(Tender enquiry no. 2425-005E dated 18.04.2024 **Due date 30.04.2024**)

ITEM: HSFG Fasteners [Rate Contract]

Sr. No.	Material Code	Material Description	Tender Quantity	Unit of Measurement	Drawing / BPS of Bolts and Nuts	Applicable TDC	Delivery Destination	
39	412400010000-CHH	M24x70 EXTENDED HSFG BOLTS&NUTS Grade8.8	3,29,012	Number	3-35-700-06802 Rev 06	TDC:5:215 Rev 01	Lara 2x800MW, Chhattisgarh	
40	412400020000-CHH	M24x90 EXTENDED HSFG BOLTS&NUTS Grade8.8	1,63,026	Number	3-35-700-06802 Rev 06	TDC:5:215 Rev 01		
41	414190003000-CHH	M30 WASHER Grade 10.9	1,33,998	Number	--	TDC:5:211 Rev 02		
42	412403013001-CHH	M30X130 EXTENDED HSFG BOLTS&NUTS GR.10.9	28,144	Number	3-35-700-09999 Rev 00	TDC:5:215 Rev 01		
43	412403017001-CHH	M30X170 EXTENDED HSFG BOLTS&NUTS GR.10.9	17,718	Number	3-35-700-09999 Rev 00	TDC:5:215 Rev 01		
44	412403009001-CHH	M30X90 EXTENDED HSFG BOLTS&NUTS GR.10.9	29,468	Number	3-35-700-09999 Rev 00	TDC:5:215 Rev 01		
45	414190003600-CHH	M36 WASHER Grade 10.9	200	Number	--	TDC:5:211 Rev 02		
46	412413619001-CHH	M36X190 EXTENDED HSFG BOLT&NUT GR.10.9	180	Number	0-86-700-A0323 Rev 00	TDC:5:215 Rev 01		
47	412371606000-ODS	BOLT-M16x60 -8.8-IS1364P1	40	SET	BPS 41237	TDC:5:211 Rev 02		Talabira 2x800MW, Sambalpur, Odisha
48	413200001600-ODS	NUT -M16 -CL8-IS1364P3	40		BPS 41320	TDC:5:211 Rev 02		
49	412371609000-ODS	BOLT-M16x90 -8.8-IS1364P1	7,060	SET	BPS 41237	TDC:5:211 Rev 02		
50	413200001600-ODS (same as Sr. no. 48)	NUT -M16 -CL8-IS1364P3	7,060		BPS 41320	TDC:5:211 Rev 02		
51	414190001600-ODS	M16 WASHER Grade 10.9	7,460	Number	--	TDC:5:211 Rev 02		
52	414190002000-ODS	M20 WASHER Grade 10.9	72,902	Number	--	TDC:5:211 Rev 02		

SPECIAL TERMS AND CONDITIONS

(Tender enquiry no. 2425-005E dated 18.04.2024 **Due date 30.04.2024**)

ITEM: HSFG Fasteners [Rate Contract]

Sr. No.	Material Code	Material Description	Tender Quantity	Unit of Measurement	Drawing / BPS of Bolts and Nuts	Applicable TDC	Delivery Destination
53	412412006001-ODS	M20X60 EXTENDED HSFG BOLTS&NUTS GR.8.8	42,788	Number	3-35-700-09998 Rev 00	TDC:5:215 Rev 01	Talabira 2x800MW, Sambalpur, Odisha
54	412412009001-ODS	M20X90 EXTENDED HSFG BOLTS&NUTS GR.8.8	32,132	Number	3-35-700-09998 Rev 00	TDC:5:215 Rev 01	
55	414180002400-ODS	M24 WASHER Grade 8.8	6,27,892	Number	--	TDC:5:211 Rev 02	
56	412400030000-ODS	M24x130 EXTENDEDHSFG BOLTS&NUTS Grade8.8	84,394	Number	3-35-700-06802 Rev 06	TDC:5:215 Rev 01	
57	412400040000-ODS	M24x170 EXTENDED HSFG BOLT &NUT Grade8.8	10,074	Number	3-35-700-06802 Rev 06	TDC:5:215 Rev 01	
58	412400010000-ODS	M24x70 EXTENDED HSFG BOLTS&NUTS Grade8.8	3,29,012	Number	3-35-700-06802 Rev 06	TDC:5:215 Rev 01	
59	412400020000-ODS	M24x90 EXTENDED HSFG BOLTS&NUTS Grade8.8	1,63,026	Number	3-35-700-06802 Rev 06	TDC:5:215 Rev 01	
60	414190003000-ODS	M30 WASHER Grade 10.9	1,33,998	Number	--	TDC:5:211 Rev 02	
61	412403013001-ODS	M30X130 EXTENDED HSFG BOLTS&NUTS GR.10.9	28,144	Number	3-35-700-09999 Rev 00	TDC:5:215 Rev 01	
62	412403017001-ODS	M30X170 EXTENDED HSFG BOLTS&NUTS GR.10.9	17,718	Number	3-35-700-09999 Rev 00	TDC:5:215 Rev 01	
63	412403009001-ODS	M30X90 EXTENDED HSFG BOLTS&NUTS GR.10.9	29,468	Number	3-35-700-09999 Rev 00	TDC:5:215 Rev 01	
64	414190003600-ODS	M36 WASHER Grade 10.9	200	Number	--	TDC:5:211 Rev 02	
65	412413619001-ODS	M36X190 EXTENDED HSFG BOLT&NUT GR.10.9	180	Number	0-86-700-A0323 Rev 00	TDC:5:215 Rev 01	

SPECIAL TERMS AND CONDITIONS

(Tender enquiry no. 2425-005E dated 18.04.2024 **Due date 30.04.2024**)

ITEM: HSFG Fasteners [Rate Contract]

Sr. No.	Material Code	Material Description	Tender Quantity	Unit of Measurement	Drawing / BPS of Bolts and Nuts	Applicable TDC	Delivery Destination
66	412371606000-HRY	BOLT-M16x60 -8.8- IS1364P1	20	SET	BPS 41237	TDC:5:211 Rev 02	Yamunanagar 1x800MW, Haryana
67	413200001600-HRY	NUT -M16 -CL8- IS1364P3	20		BPS 41320	TDC:5:211 Rev 02	
68	412371609000-HRY	BOLT-M16x90 -8.8- IS1364P1	3,530	SET	BPS 41237	TDC:5:211 Rev 02	
69	413200001600-HRY (same as Sr. no. 67)	NUT -M16 -CL8- IS1364P3	3,530		BPS 41320	TDC:5:211 Rev 02	
70	414190001600-HRY	M16 WASHER Grade 10.9	3,730	Number	--	TDC:5:211 Rev 02	
71	414190002000-HRY	M20 WASHER Grade 10.9	36,451	Number	--	TDC:5:211 Rev 02	
72	412412006001-HRY	M20X60 EXTENDED HSFG BOLTS&NUTS GR.8.8	21,394	Number	3-35-700-09998 Rev 00	TDC:5:215 Rev 01	
73	412412009001-HRY	M20X90 EXTENDED HSFG BOLTS&NUTS GR.8.8	16,066	Number	3-35-700-09998 Rev 00	TDC:5:215 Rev 01	
74	414180002400-HRY	M24 WASHER Grade 8.8	3,13,946	Number	--	TDC:5:211 Rev 02	
75	412400030000-HRY	M24x130 EXTENDEDHSFG BOLTS&NUTS Grade8.8	42,197	Number	3-35-700-06802 Rev 06	TDC:5:215 Rev 01	
76	412400040000-HRY	M24x170 EXTENDED HSFG BOLT &NUT Grade8.8	5,037	Number	3-35-700-06802 Rev 06	TDC:5:215 Rev 01	
77	412400010000-HRY	M24x70 EXTENDED HSFG BOLTS&NUTS Grade8.8	1,64,506	Number	3-35-700-06802 Rev 06	TDC:5:215 Rev 01	
78	412400020000-HRY	M24x90 EXTENDED HSFG BOLTS&NUTS Grade8.8	81,513	Number	3-35-700-06802 Rev 06	TDC:5:215 Rev 01	
79	414190003000-HRY	M30 WASHER Grade 10.9	66,999	Number	--	TDC:5:211 Rev 02	

SPECIAL TERMS AND CONDITIONS

(Tender enquiry no. 2425-005E dated 18.04.2024 **Due date 30.04.2024**)

ITEM: HSFG Fasteners [Rate Contract]

Sr. No.	Material Code	Material Description	Tender Quantity	Unit of Measurement	Drawing / BPS of Bolts and Nuts	Applicable TDC	Delivery Destination
80	412403013001-HRY	M30X130 EXTENDED HSFG BOLTS&NUTS GR.10.9	14,072	Number	3-35-700-09999 Rev 00	TDC:5:215 Rev 01	Yamunanagar 1x800MW, Haryana
81	412403017001-HRY	M30X170 EXTENDED HSFG BOLTS&NUTS GR.10.9	8,859	Number	3-35-700-09999 Rev 00	TDC:5:215 Rev 01	
82	412403009001-HRY	M30X90 EXTENDED HSFG BOLTS&NUTS GR.10.9	14,734	Number	3-35-700-09999 Rev 00	TDC:5:215 Rev 01	
83	414190003600-HRY	M36 WASHER Grade 10.9	100	Number	--	TDC:5:211 Rev 02	
84	412413619001-HRY	M36X190 EXTENDED HSFG BOLT&NUT GR.10.9	90	Number	0-86-700-A0323 Rev 00	TDC:5:215 Rev 01	

In material Code column of the above table : ODA symbolizes for Delivery Destination as ODisha Angul; similarly CHH for CHHatisgarh; ODS for ODisha Sambalpur; and HRY for HaRYana)

Additional Information:

- A. For 16 items at Sr. no. 1 to 4, 28 to 31, 47 to 50, 66 to 69 : The bidder has to quote for both Bolt and Nut. L1 comparison / evaluation to be done in SETS only. Also, the material should be supply in assembled condition only.
- (i) "1 SET" of Quantity = 1 Bolt and its corresponding Nut.
 - (ii) Applicable TDC is TDC:5:211 Rev 02.
 - (iii) Bolts / Nuts are to be supplied as per relevant BOS Document & TDCs.
 - (iv) Quoting in single item only, in place of both items of set, quotation for that single item will not be considered for further processing.
- B. For 20 items at Sr. no. 5, 6, 11, 17, 22, 32, 33, 36, 41, 45, 51, 52, 55, 60, 64, 70, 71, 74, 79 and 83: where Material Description is 'WASHER'
- (i) "1 number" of Quantity = 1 Washer.
 - (ii) Applicable TDC is TDC:5:211 Rev 02.
 - (iii) Washers to be supplied as per relevant TDC only.
- C. For the remaining 48 items, where Material Description is 'EXTENDED HSFG BOLTS and NUTS'
- (i) "1 number" of Quantity = 1 Bolt + 1 Nut.
 - (ii) Applicable TDC is TDC : 5 : 215 Rev 01.
 - (iii) Bolts are to be supplied as per Drawings & TDCs.
- D. Applicable 'Standard Quality Plan' for all the items: SQP:HSFG:001 dated 26.03.2024.



SPECIAL TERMS AND CONDITIONS

(Tender enquiry no. 2425-005E dated 18.04.2024 **Due date 30.04.2024**)

ITEM: HSFG Fasteners [Rate Contract]

- E. *Rust preventive coating is to be applied on all the items, as per attached specification with document reference no. PR:CHEM:09-04 Rev 03 dated 01.04.2009, is to be applied.*
- F. *Above mentioned quantity is tentative and actual ordering may vary from above stated quantity.*
- G. *Minimum 50% and 20% Local Content required for qualifying as Class 1 and Class 2 Local Supplier respectively.*

Delivery Destination for the above 84 items are as follows: -

Sr. no. 1 to 27:

Project Name: Talcher 2x660MW
Address: NTPC Talcher TPP Stage-III
2x660 MW Angul,
Odisha - 759101

Sr.no. 28 to 46:

Project Name: Lara 2x800MW
Address: NTPC Lara STPP
Stage-II 2 x 800 MW
Pussore, Chappora
Chhattisgarh - 496440

Sr.no. 47 to 65:

Project Name: Talabira 2x800MW
Address: Talabira 2x800MW,
Village Talabira, Distt: Sambalpur,
Odisha

Sr. no. 66 to 84:

Project Name: Yamunanagar 1x800MW
Address: Yamunannagar, Haryana

S2 PRE-QUALIFICATION CRITERIA (PQC)

- a) Supplier shall be manufacturer of Fasteners. Offers from Traders/Dealers/Stockists/agents will be rejected. Submission of UDYAM Certificate or Declaration from bidder is required to fulfil this criterion.
- b) Bidder should have Minimum Average Annual Financial Turnover of Rs. [as mentioned in Table 2 below] for each project, over three financial years viz. FY 2020-21, 2021-22 and 2022-23. To certify the same, bidder need to submit balance sheets of above stated three years. Balance sheets should be audited, as applicable. The value of turnover to be considered is without Taxes. If the balance sheets are not audited, bidder need to submit CA certificate for the turnover. **Audited balance sheets/CA certificate with valid UDIN (Unique Document Identification Number) will only be considered in order of fulfill this criterion.**

Start-ups shall be exempted from the above pre-qualification criteria Sr. no. 3, without any relaxation in quality standards or technical parameters as per D.O. No. 5(4)/2016-BE-I dated 15.02.2017. For claiming Start-Up exemption, vendors have to submit DPIIT (Dept. of Promotion of Industry and Internal Trade)/DIPP (Department for Industrial Policy and Promotion) recognition certificates.)



SPECIAL TERMS AND CONDITIONS
(Tender enquiry no. 2425-005E dated 18.04.2024 **Due date 30.04.2024**)
ITEM: HSF8 Fasteners [Rate Contract]

Table - 2

Sr. no.	Tender Enquiry Sr. no.	Project Name	Minimum Avg. Annual Turnover Required, Rs.
A	1 to 27	Talcher 2x660MW, Angul, Odisha	3.00 Crores
B	28 to 46	Lara 2x800MW, Chhattisgarh	1.50 Crores
C	47 to 65	Talabira 2x800MW, Sambalpur, Odisha	1.50 Crores
D	66 to 84	Yamunanagar 1x800MW, Haryana	1.00 Crores

If bidder is quoting for more than one project, then minimum average annual turnover value of bidder should be sum of the values mentioned corresponding to each project.

Example 1: Suppose one bidder is having the Average Annual Financial Turnover of Rs. 4 crores. Then bidder can quote for the projects, where sum of values mentioned in ‘Minimum Avg. Annual Turnover Value’ is less than or equal to 4 Crores. Like-wise, -

- for either of projects as mentioned in A / B / C / D, as individually each project requirement against T.O. criteria is less than Rs. 4 Crores.
- for Project A + D; Cumulative T.O. requirement reaches to Rs. 4.00 Crores,
- for Project B + C +D; Cumulative T.O. requirement reaches to Rs. 4.00 Crores, etc.

Same Bidder should not quote for the cases where the sum of values mentioned in ‘Minimum Avg. Annual Turnover Value’ crosses Rs. 4 Crores. Like-wise: -

- for Project A + B; Cumulative T.O. requirement reaches to Rs. 4.50 Crores,
- for Project A + C; Cumulative T.O. requirement reaches to Rs. 4.50 Crores, etc.

- c) Bidder has to submit one or more purchase order/s of ‘similar item’ from any customer with minimum cumulative value of Rs. [as mentioned in Table 3 below] along with the proof of execution like Invoice / Consignee Receipt Note / Completion Certificate, from any customer(s). PO date should be 01.04.2021 or afterwards till bid opening date”. PO value mentioned above is net of taxes. The details of the submitted POs along with its proof of execution must be filled as per attached Annexure - P. **Also, please note that the proof of execution like Invoice / Consignee Receipt Note / Completion Certificate must include the Purchase Order reference number, otherwise that PO will not be considered for the fulfilment of this tender term.**

Sr. no.	Tender Enquiry Sr. no.	Project Name	Minimum cumulative value of PO, Rs.
A	1 to 27	Talcher 2x660MW, Angul, Odisha	1.50 Crores
B	28 to 46	Lara 2x800MW, Chhattisgarh	0.80 Crore
C	47 to 65	Talabira 2x800MW, Sambalpur, Odisha	0.80 Crore
D	66 to 84	Yamunanagar 1x800MW, Haryana	0.60 Crore

“**Similar item**” has been defined as “Bolts, Nuts or Washers as per standard as per below table 4: -



SPECIAL TERMS AND CONDITIONS

(Tender enquiry no. 2425-005E dated 18.04.2024 **Due date 30.04.2024**)

ITEM: HSFSG Fasteners [Rate Contract]

Table - 4

Item	Standard	Equivalent
Bolt	Grade 8.8 or above as per: IS-1364 (Latest) part-1; IS-1367 (Latest) part-3; IS-3757 (Latest)	EN 14399-3 (Latest) Property Class: 8.8 or above; EN ISO 898-1 for Mechanical Properties Or equivalent ISO standard
Nut	Grade 8 or above as per: IS-6623 (Latest) IS-1364 (Latest)	EN 14399-3 (Latest) Property Class: 8 or above; Or equivalent ISO standard
Washer	Grade 8 or above as per: IS-6649 (Latest)	EN 14399-5 (Latest) Or equivalent ISO standard

If bidder is quoting for more than one project, then minimum Cumulative Value of PO along with corresponding value of proof of execution like invoice, etc., will be sum of the values mentioned corresponding to each project.

Start-ups shall be exempted from this criterion of Purchase order and invoice submission without **Start-ups shall be exempted** from the above pre-qualification criteria, without any relaxation in quality standards or technical parameters as per D.O. No. 5(4)/2016-BE-I dated 15.02.2017. For claiming Start-Up exemption, vendors have to submit DPIIT (Dept. of Promotion of Industry and Internal Trade)/DIPP (Department for Industrial Policy and Promotion) recognition certificates.)

Example 2: (In continuation to the Example 1) Suppose one bidder is having the Average Annual Financial Turnover of Rs. 4 crores and submitted the Purchase Orders of cumulative value of Rs. 1.50 Crores, then although financially he is eligible to quote for projects A and D, but due to submitted PO value constraint, he is eligible for only one project A or D.

- d) Bidder shall have capacity to supply minimum of [MT as per in Table 5 below] of HSFSG Fasteners per month for each project, for the order placed by BHEL IVP Goindwal. Confirmation from bidder is required to fulfil this criterion.

Table – 5

Sr. no.	Tender Enquiry Sr. no.	Project Name	Minimum Quantity of Fasteners, in MT/Month
A	1 to 27	Talcher 2x660MW, Angul, Odisha	30 MT
B	28 to 46	Lara 2x800MW, Chhattisgarh	15 MT
C	47 to 65	Talabira 2x800MW, Sambalpur, Odisha	15 MT
D	66 to 84	Yamunanagar 1x800MW, Haryana	10 MT

If bidder is quoting for more than one project, then minimum spare capacity of bidder will be sum of the values mentioned corresponding to each project.

Example 3: (In continuation to the Example 1 and 2) Suppose one bidder is having the Average Annual Financial Turnover of Rs. 4 crores and submitted the Purchase Orders of cumulative value of Rs. 1.50 Crores, then although financially he is eligible to quote for projects A and D, but due to submitted PO value constraint, he is eligible for only one project either A or D. Further, if **the same bidder** declares spare capacity of manufacturing Fasteners as 20 MT, then although as per the Turnover criteria, he is eligible to



SPECIAL TERMS AND CONDITIONS

(Tender enquiry no. 2425-005E dated 18.04.2024 **Due date 30.04.2024**)

ITEM: HCFG Fasteners [Rate Contract]

quote for projects A and D, but due to submitted PO value constraint and minimum spare capacity constraint, he is eligible for only one project i.e. D.

BHEL may carry out evaluation of bidder's capability. BHEL reserves the right to accept/reject any offer based on evaluation of bidder's capability. BHEL may decide to visit the bidder(s) works. Any fact found deviating from bids during evaluation shall make the bidder liable to be dis-qualified.

S3 PART-I: TECHNO-COMMERCIAL BID

Techno - Commercial Bid should contain *all the documents/confirmations as per following details:*

- a) Acceptance of Techno-Commercial terms and conditions shall be attached along with bid document. This can be attached either by signing each page of terms and conditions or a confirmation statement.

IF THE OFFER IS NOT ACCOMPANIED WITH ACCEPTANCE OF TERMS AND CONDITIONS, IT SHALL BE CONCLUDED THAT ALL THE TERMS AND CONDITIONS ARE ACCEPTABLE AND NO CLAIM WHATSOEVER SHALL BE ENTERTAINED LATER ON.

IF THERE IS ANY DEVIATION IN REFERENCE TO ANY OF THE TENDER TERM, KINDLY MENTION IN PART-I TECHNO-COMMERCIAL BID ONLY. DEVIATION SPECIFIED ELSEWHERE, WILL NOT BE CONSIDERED.

- b) MSE vendors should submit **UDYAM Registration Certificate** for availing applicable benefits for MSE vendors as per tender terms. Validity of document shall be considered as on date of Part I opening as per the latest available notification from Government.
- c) Documents as per pre-qualification terms.
- d) Monthly commitment in MT to be mentioned in bid.
- e) Duly filled Annexure - P (Details of Submitted PO and their Proof of Execution, as per above stated PQC term at Sr. no. S2. c))
- f) Duly filled Annexure – Q (Confirmations of Special terms)
- g) Duly Filled Annexure - R (Integrity Pact)
- h) Duly Filled Annexure - S (Make in India Declaration Certificate from CA along with valid UDIN), wherever applicable.

Make in India (MII) Declaration Certificate is required from CA statutory auditor of the company (in case of companies) or from a practicing cost accountant or practicing chartered accountant (in respect of suppliers other than companies) giving the percentage of local content, only when the Bidder is quoting for More than one Project Sites.

For participating in single project (any one of the four projects sites) no such additional Declaration Certificate is required.

S4 DELIVERY SCHEDULE

Delivery shall be within THREE MONTHS from date of release of Purchase Order under this Rate Contract. In case of non-acceptance of this term, bid shall be liable for rejection.



SPECIAL TERMS AND CONDITIONS

(Tender enquiry no. 2425-005E dated 18.04.2024 **Due date 30.04.2024**)

ITEM: HSFG Fasteners [Rate Contract]

In case of special requirements, BHEL may ask vendor/s to supply with lesser delivery schedule, which shall be mentioned in the purchase orders. In such cases, delivery extension may be given to vendor for equal load in other pending purchase orders.

S5 SCOPE OF UNLOADING

Unloading of Material at various project sites is in the Scope of respective BHEL Site Office.

S6 VALIDITY OF OFFERS

Bids shall be valid for tender finalization till 30th June 2024.

S7 VALIDITY OF CONTRACT

The rate contract will be in operation for **EIGHTEEN-MONTHS** period from the date of finalization of this tender enquiry. All Purchase orders will be released in this contract period only.

However, BHEL reserves the right to terminate the contract earlier also if the performance of the VENDOR is not satisfactory. This rate contract can be extended again for period of further one more year on mutual agreement.

S8 PRICE BASIS

- Rates shall be quoted on rate INR per Unit basis, Net of taxes & on FOR DESTINATION basis. Comparison shall be made on landed rate per Unit Basis to the respective delivery destination for deciding L1 offer. Evaluation shall be done line item wise.
- Order of enquiry item Sl. no. shall be maintained in the quotation.
- Finalized rates shall be reckoned as base rates and the date for base indices shall be taken as 30.04.2024. Finalized rates shall be valid upto 30th June 2024 from date of technical bid opening.
- Further, PVC shall be calculated from 1st July 2024 and shall be valid for 2 months. Thereafter, frequency of calculating rates will be two months as per Price Variation Clause. POs shall be released on this revised price for two months period.

S9 PRICE VARIATION CLAUSE FORMULA

HSFG Fasteners prices shall be revised based on the prices of MS Rounds 22/25, labor & Fuel & Power index. Price variation due to change in any other input shall not be considered during the validity of rate contract. Revised rates shall be arrived at by using following formulae:

$$X_n = X_o + 0.60 \Delta M + 0.10 \Delta L + 0.15 \Delta E$$

In the formula ΔM , ΔE & ΔL are taken as below:

$$\Delta M = \frac{(M_n - M_o) * X_o}{M_o}$$

$$\Delta E = \frac{(E_n - E_o) * X_o}{E_o}$$

$$\Delta L = \frac{(L_n - L_o) * X_o}{L_o}$$



SPECIAL TERMS AND CONDITIONS

(Tender enquiry no. 2425-005E dated 18.04.2024 **Due date 30.04.2024**)

ITEM: HSFG Fasteners [Rate Contract]

Table 6

TERMS USED (Please refer illustration)		Illustration for PVC price calculation for period 01.07.2024-31.08.2024
X_o	Finalized price will be valid upto declared date (30.06.2024) and will be taken as base for further PVC calculations.	e.g. Say, finalized price are valid upto 30.06.2024.
X_n	Revised price of the material to be declared after every two months. POs shall be released on this revised price for two months period.	e.g. PVC prices are to be calculated for 01.07.2024-31.08.2024 for release of POs during this period.
Mo	Average of weekly MS Rounds 22/25 prices (per Ton) from MMR (Avg of two months prior to 30.04.2024).	e.g. Mo calculation shall be avg of weekly MS Rounds 22/25 prices for the period of 01.03.2024-30.04.2024
Mn	Average of weekly MS Rounds 22/25 prices (per Ton) from the MMR (Avg for preceding two months when the price is being revised)	e.g. Mn calculation shall be avg of weekly MMR MS Rounds 22/25 prices for the period of 01.05.2024-30.06.2024
ΔE	<p>Change in Wholesale Price Index Numbers– All-India basis reference taken from >publications>>Monthly>>RBI">www.rbi.org.in/home.aspx>>publications>>Monthly>>RBI bulletin>>Prices [Table no. 21]-1.2: Latest available Indices (provisional or final) shall be considered for calculating the average. ΔE will be calculated as per below formula:</p> <p>$\Delta E = (E_n - E_o) * X_o / E_o$; where E₀ is average base index for Fuel & Power for two months prior to previous one month of 30.04.2024. E_n is average index for Fuel & Power for two months prior to previous one month of revision of PVC rates.</p>	E _o calculation shall be avg index for fuel & power for Feb & Mar 2024 and E _n calculation shall be avg index for Apr & May 2024.
ΔL	<p>Change in Consumer Price Index Numbers for Industrial Workers – All-India basis reference taken from >publications>>Monthly>>RBI">www.rbi.org.in/home.aspx>>publications>>Monthly>>RBI bulletin>>Prices [Table no. 19]-1. Latest available Indices (provisional or final) shall be considered for calculating the average. ΔL will be calculated as per below formula:</p> <p>$\Delta L = (L_n - L_o) * X_o / L_o$; where L₀ is average base index for labour for two months prior to previous two months of 30.04.2024. L_n is average index for Labour for two months prior to previous two months of revision of PVC rates.</p>	L _o calculation shall be avg index for labour for Jan 2024 & Feb 2024 and L _n calculation shall be avg index for Mar & Apr 2024.



SPECIAL TERMS AND CONDITIONS
(Tender enquiry no. 2425-005E dated 18.04.2024 **Due date 30.04.2024**)
ITEM: HSFG Fasteners [Rate Contract]

S10 REVERSE AUCTION

For 16 items at Sr. no. 1 to 4, 28 to 31, 47 to 50, 66 to 69, where the evaluation is done in Sets, Reverse auction will not be conducted.

For the remaining items in this tender enquiry, Reverse Auction will be conducted

S11 VENDOR REGISTRATION

Bidders, who are not currently on registered list of BHEL IVP Goindwal Sahib, may submit their application for vendor registration through online system on www.bhel.com. Direct link for online supplier registration is <https://supplier.bhel.in/>. This application submission can be done separately/immediately without waiting for the tender opening.

S12 LOADING CRITERIA CUM COUNTER OFFER

Loading shall be done as per following criteria subject to fulfilment of MSE clause:

Case - I: For Forty (40) Items, as shown in table - 7 below, 100% loading will be done on L1 bidder.

Table - 7

Sr. no.	Project Name	Tender Enquiry Sr. no.	Count of Items
A	Talcher 2x660MW, Angul, Odisha	1, 2, 3, 4, 5, 7, 8, 13, 14, and 20	10
B	Lara 2x800MW, Chhattisgarh	28, 29, 30, 31, 32, 33, 38, 45 and 46	9
C	Talabira 2x800MW, Sambalpur, Odisha	47, 48, 49, 50, 51, 52, 57, 64 and 65	9
D	Yamunanagar 1x800MW, Haryana	66, 67, 68, 69, 70, 71, 72, 73, 76, 79, 83, and 84	12
Total Items			40

Case -II: For Twenty-Nine (29) Items, as shown in table - 8 below, counter offer of L1 rates will be issued to L2 bidder.

Table - 8

Sr. no.	Project Name	Tender Enquiry Sr. no.	Count of Items
A	Talcher 2x660MW, Angul, Odisha	6, 10, 11, 12, 17, 18, 19, 21, 26 and 27	10
B	Lara 2x800MW, Chhattisgarh	34, 35, 36, 41, 42, 43 and 44	7
C	Talabira 2x800MW, Sambalpur, Odisha	53, 54, 55, 60, 61, 62 and 63	7
D	Yamunanagar 1x800MW, Haryana	74, 75, 80, 81 and 82	5
Total Items			29

Loading shall be done on vendor as per below mentioned criteria, subject to acceptance of counter offered L1 rates:



SPECIAL TERMS AND CONDITIONS
 (Tender enquiry no. 2425-005E dated 18.04.2024 **Due date 30.04.2024**)
ITEM: HSPG Fasteners [Rate Contract]

Vendor	L1	L2
% Loading	60%	40%

If L2 does not accept the counter offer for any particular any item/items, entire 100% quantity shall be loaded upon L1 bidder.

Case-III: For Eight (8) Items, as shown in table -9 below, counter offer of L1 rates will be issued to L2 and L3 vendors.

Table -9

Sr. no.	Project Name	Tender Enquiry Sr. no.	Count of Items
A	Talcher 2x660MW, Angul, Odisha	9, 16, 22 and 24	4
B	Lara 2x800MW, Chhattisgarh	37	1
C	Talabira 2x800MW, Sambalpur, Odisha	56	1
D	Yamunanagar 1x800MW, Haryana	77 and 78	2
Total Items			8

Loading shall be done on vendor as per below mentioned criteria, subject to acceptance of counter offered L1 rates:

Vendor	L1	L2	L3
% Loading	50%	30%	20%

Based on acceptance of counter offer rates from L2 and L3 vendors: -

- In case out of L2 and L3 vendor, only one vendor accepts the counter offer rates, then loading ratio applicable will be 60%:40%.
- If no one accepts the counter offer for any particular any item/items, entire 100% quantity shall be loaded upon L1 vendor.

Case-IV: For Seven (7) Items, as shown in table - 10 below, counter offer of L1 rates will be issued to L2, L3 and L4 vendors.

Table -10

Sr. no.	Project Name	Tender Enquiry Sr. no.	Count of Items
A	Talcher 2x660MW, Angul, Odisha	15, 23 and 25	3
B	Lara 2x800MW, Chhattisgarh	39 and 40	2
C	Talabira 2x800MW, Sambalpur, Odisha	58 and 59	2
D	Yamunanagar 1x800MW, Haryana	--	0
Total Items			7

Loading shall be done on vendor as per below mentioned criteria, subject to acceptance of counter offered L1 rates:

Vendor	L1	L2	L3	L4
% Loading	38%	25%	20%	17%

Based on acceptance of counter offer rates from L2, L3 and L4 vendors: -



SPECIAL TERMS AND CONDITIONS

(Tender enquiry no. 2425-005E dated 18.04.2024 **Due date 30.04.2024**)

ITEM: HSFG Fasteners [Rate Contract]

- In case, only two vendors accept the counter offer rates, then loading ratio applicable will be 50%:30%:20% based on their ranking
- In case, only one vendor accepts the counter offer rates, then loading ratio applicable will be 60%:40%.
- If no one accepts the counter offer for any particular any item/items, entire 100% quantity shall be loaded upon L1 vendor.

Note: The above criteria mentioned in cases I, II, III and IV is subject to fulfilment of MSE clause. In case loading on vendors is not meeting the MSE clause, then equal deduction will be done from the non-MSE vendors, to meet the MSE Purchase preference criteria [refer Clause no. 26 of General Contract Conditions of the tender].

Above indicated criteria is liable to be monitored/controlled/regulated by BHEL from the first ordering itself. Subsequent ordering will be depending upon execution of orders by suppliers and BHEL requirement.

Once the rate contract is in place with various vendors based on acceptance of counter offer, while placing regular Purchase orders, BHEL will place orders for required quantity based on BHEL delivery requirement, pending POs at any time with vendor and vendor's monthly commitment of HSFG Fasteners in MT, delivery records and quality.

S13 QUANTITY VARIATION

+ 5% Variation in the quantity is applicable for all the items in the tender.

S14 COMPLIANCES

- a) Bidder has to manufacture and supply the material complying all the latest applicable Notifications / Orders issued by the Bureau of Indian standards (BIS) or any Government agency.
- b) The Gazette notification no. CG-DL-E-22072023-247533 dt. 21.07.2023 applicable to these fasteners may be referred. The bidder has to confirm that material to be supplied shall in compliance to latest BIS guidelines issued and amended till date of supply.
- c) Purchase Orders on suppliers approved in this Rate Contract shall be placed, provided they comply to latest BIS Requirements applicable on the date of PO release.

S15 PACKING OF MATERIAL

- a) Packing of HSFG Fasteners shall not exceed the 25 kgs per gunny bag.
- b) Gunny bags shall be put inside wooden boxes with maximum acceptable weight of 3 MT for each box.
- c) Clubbing of different variants of HSFG Fasteners in one single wooden box is not acceptable.
- d) Vendor shall try to minimize number of boxes to possible extent without violating any of the packing instructions.

S16 DETENTION CHARGES – WHILE UNLOADING AT SITE

The detention charges shall be payable as: -

@ Rs. 800/- for Part Loads i.e. for vehicle carrying load below 5.5 MT per vehicle per day;

@ Rs.1700/- for vehicle carrying load above 5.5 MT and below 18 MT per vehicle per day and



SPECIAL TERMS AND CONDITIONS

(Tender enquiry no. 2425-005E dated 18.04.2024 **Due date 30.04.2024**)

ITEM: HSFG Fasteners [Rate Contract]

@ Rs. 2200/- for vehicle carrying load above 18MT per vehicle per day, detention charges shall be on each occasion subject to detention of vehicle in plant/site beyond a period defined as given below: -

Unloading Points	Free Period in days excluding Day of entry, day of exit, Sunday and Holiday declared at respective Project Site
Stores Wards of BHEL Units	2
Sites / Other Locations	2

[Weight of material will be considered as mentioned in Lorry Receipt generated by the Transporter or as per the Packing list/ Invoice generated by the Vendor, whichever is lower]

Day of entry, day of exit, Sunday and Holiday declared at respective Project Site shall be exclude from total detention period.

However, in such cases Supplier will have to submit proof of entry and exit day of vehicle in the plant/port/site.

Immediately on reaching the site, vendor shall have to inform the reaching/site entry date. In case they are not allowed inside the site/works, then vendor will inform through email along with GPS data / Photographs / Videos / etc. as the proof of the vehicle reaching at site. Please note that vehicle registration number and the site gate / board / etc. must be visible on the submitted photographs/ Video / etc.

In such cases, date on which email with GPS data / Photograph/ etc., is received at BHEL IVP Goindwal will be considered as the date of arrival of vehicle at site/Stores. The decision of BHEL in this regard shall be final.

Total detention charges shall be limited to 50% of the basic freight. An approval from BHEL shall be obtained for payment of detention charges more than 50% of the basic freight in exceptional cases.

For example, if the vehicle reached at site for unloading and made IN entry on 01.04.2024, the free period (2 days as per above table) will be available up to 03.04.2024. However, if the EXIT entry of the vehicle is made on 06.04.2024, then detention will be calculated excluding 06.04.2024 and free period (2 days) and two days will be eligible for detention.

S17 INSPECTION

Bidders will submit TPI (Third party inspection) / BHEL Inspection report to BHEL IVP after inspection. Then based on Inspection report, BHEL will give dispatch clearance and then only the material shall be supplied to the respective consignee address.

BHEL will provide dispatch clearance **within 7 working days** of receipt of complete quality cleared documents.

S18 INTEGRITY PACT (IP)

- IP is a tool to ensure that activities and transactions between the Company and its Bidders/ Contractors are handled in a fair, transparent and corruption free manner. Following independent External Monitors (IEMs) on the present panel have been appointed by BHEL with the approval of CVC to oversee implementation of IP in BHEL.



SPECIAL TERMS AND CONDITIONS

(Tender enquiry no. 2425-005E dated 18.04.2024 **Due date 30.04.2024**)

ITEM: HSFG Fasteners [Rate Contract]

Sl. no.	IEM	Email ID
1.	Shri Otem Dai, IAS (Retd.)	iem1@bhel.in
2.	Shri Bishwamitra Pandey, IRAS (Retd.)	iem2@bhel.in
3.	Shri Mukesh Mittal, IRS (Retd.)	iem3@bhel.in

- b) The IP as enclosed with the tender (Annexure – R) is to be submitted (duly signed by authorized signatory) along with techno-commercial bid (Part-I, in case of two / three-part bid). Only those bidders who have entered into such an IP with BHEL would be competent to participate in the bidding. In other words, entering into this Pact would be a preliminary qualification.
- c) Please refer Section-8 of IP for Role and Responsibilities of IEMs. In case of any complaint arising out of the tendering process, the matter may be referred to any of the above IEM(s). All correspondence will the IEMs shall be done through email only.

Note:

No routine correspondence shall be addressed to the IEM (phone / post / email) regarding the clarifications, time extensions or any other administrative queries, etc. on the tender issued. All such clarification / issues shall be addressed directly to the tender issuing (procurement) department's official whose contact details are provided below:

Details of contact person(s):

Name	Sumeet Bansal	Pranshu
Department	Material Management	Material Management
Address	433, Industrial Complex, IVP Goindwal, Dist. Tarn Taran Punjab 143422	433, Industrial Complex, IVP Goindwal, Dist. Tarn Taran Punjab 143422
Phone: (Landline / Mobile)	01859-224628 / 9878006105	01859-224685 / 9464679705
Email	sbansal@bhel.in	pranshu@bhel.in

S19 DIFFERENTIAL FREIGHT CLAUSE

The rates finalized against each schedule shall include cost of transporting finished products from Vendor's Works to delivery location specified in the tender.

All the consignments are normally envisaged for dispatch from Vendor's Works to specified location in the tender. However, in exceptional cases (in case of Project hold/ any unforeseen conditions), BHEL may permit Vendor(s) on case to case basis for handing over the consignments to some new location. BHEL's decision shall be final in this regard. In such case, differential freight charges shall be deducted or paid based on applicable distance.

Differential Rates will be calculated as below:

If BHEL advises to despatch material at any other location, then BHEL will calculate freight portion from vendor works to Location specified in tender (say it comes out amount 'X') and from vendor works to New location specified by BHEL (say it comes out amount 'Y'). Then differential freight cost will be calculated by subtracting both freight cost (Y-X). If it comes out to be positive, then this differential cost shall be given extra to vendor. If it comes out to be negative, then this differential amount shall be deducted from vendor. Kindly note that this extra payment to vendor/deduction from vendor shall be amended suitable in Purchase order before despatch.



SPECIAL TERMS AND CONDITIONS

(Tender enquiry no. 2425-005E dated 18.04.2024 **Due date 30.04.2024**)

ITEM: HSFG Fasteners [Rate Contract]

For Calculation of Transportation freight, BHEL has mentioned Rate/KM/MT in INR from anywhere to anywhere in India. For calculating total cost, this needs to be multiplied by distance in KM & weight in MT. **Rate/KM/MT from anywhere to anywhere is mentioned below:**

Relevant category	Freight Rate per MT per KM	Remarks
TAAA2	3.30	Anywhere to anywhere

Distance shall be taken in KM as shortest distance from Google map.

Example: Suppose one vendor is located in Ludhiana (Punjab). Distance from Ludhiana to BHEL Goindwal is approx. 150 KM & distance from Ludhiana to Talcher site is approx.1900 KM. The specified destination in tender is Talcher and the new location specified for delivery of material is Goindwal. Suppose weight of consignment is 60 MT

Then freight from Ludhiana to Goindwal (Y) comes out to be Rs. $3.30 \times 150 \times 60 = \text{Rs. } 29,700.00$. The freight from Ludhiana to Talcher (X) comes out to be Rs. $3.30 \times 1900 \times 60 = 3,76,200.00$. Now differential cost (Y-X) comes out to be Rs. (-)3,46,500.00. Hence this differential amount will be deducted from vendor.

S20 CUSTOMER APPROVAL OF VENDORS

For Talcher 2x660MW, Angul, Odisha Project (Sr. no. 1 to 27) and for Lara 2x800MW, Chhattisgarh (Sr. no. 28 to 46) :

No approval of vendor from the customer is required.

For Talabira 2x800MW, Sambalpur, Odisha Project (Items at Sr. no. 47 to 65) and for Yamunanagar 1x800MW, Haryana Project (Items at Sr. no. 66 to 84) :

In case of Customer approval is applicable for these two projects, Price of only those Techno Commercially suitable bidders shall be considered who are approved by customer.

For customer approval, BHEL may ask for additional documents as required by BHEL customer

S21 PERFORMANCE SECURITY (PS)

Successful bidders are required to submit performance security of Rs 2.0 lakhs after entering into rate contract with successful bidders. Performance security shall be valid for a period of **41 months**. Successful bidder (L1 or counter-offer accepted) has to submit Performance Security within 21 days from the date of placement of first purchase order under RC. As per the general conditions of the contract, warranty of 18 months is applicable from the receipt of the goods. This PS will be released to the vendor without interest after two months beyond the completion of all the contractual obligations.

Performance Security shall not carry any interest. Vendor has to submit written request to BHEL for refund of PS well in advance before the due date.

In case of completion of contractual obligations before 41 months, performance security shall be released to the bidder on his request. In case of non-completion of contractual obligations in 41 months, supplier shall be required to extend the validity of the performance security till the completion of all contractual obligations.

Modes of Deposit: Performance security may be furnished in the following forms:



SPECIAL TERMS AND CONDITIONS

(Tender enquiry no. 2425-005E dated 18.04.2024 **Due date 30.04.2024**)

ITEM: HSFSG Fasteners [Rate Contract]

- i. Local cheques of Scheduled Banks (subject to realization)/ Pay Order/Demand Draft/ Electronic Fund Transfer in favour of BHEL.

BHEL IVP Goindwal Bank Details for Reference: -

Beneficiary Name: BHARAT HEAVY ELECTRICALS LIMITED

Beneficiary Account no.: 40179740806

Bank Name: STATE BANK OF INDIA

Branch Name: GOINDWAL SAHIB

IFSC Code: SBIN0010743

- ii. Bank Guarantee from Scheduled Banks / Public Financial Institutions as defined in the Companies Act. The Bank Guarantee format should have the approval of BHEL.
- iii. Fixed Deposit Receipt issued by Scheduled Banks / Public Financial Institutions as defined in the Companies Act (FDR should be in the name of the Contractor, a/c BHEL)
- iv. Securities available from Indian Post offices such as National Savings Certificates, Kisan Vikas Patras etc. (held in the name of Contractor furnishing the security and duly endorsed/ hypothecated/ pledged, as applicable, in favour of BHEL)
- v. Insurance Surety Bond
- vi. By way of retention from dues available in the form of Bills payable to the supplier against same / other contracts in the same unit.

In case of non-submission of performance security within stipulated time (i.e. 21 days from the date of placement of first purchase order under RC), then BHEL will hold the equivalent amount in lieu of Performance Security from the dues available in the form of Bills, Security Deposit, etc. payable to the supplier against same / other contracts in the same unit.

In case where the amount of dues available comes out to be less than the value of required Performance Security, it will amount to breach of contract.

(Note: BHEL will not be liable or responsible in any manner for the collection of interest or renewal of the documents or in any other matter connected therewith).

Forfeiture of Performance Security: The performance security will be forfeited and credited to BHEL's account in the event of a breach of contract by the supplier.

S22 BREACH OF CONTRACT AND TERMINATION

In case of breach of contract, wherever the value of security instruments like performance bank guarantee available with BHEL against the said contract is 10% of the contract value or more, such security instruments to the extent of 10% contract value will be uncashed. In case of breach of contract i.e. single/multiple purchase orders released under RC, 10 % of the corresponding PO value shall be deducted from the defaulted supplier. In case the value of the security instruments available is less than 10% of the contract value, the balance amount be recovered in all or any of the following manners:

1. from dues available in the form of Bills payable to defaulted supplier against the same contract.
2. from the dues payable to defaulted supplier against other contracts in the same Region/Unit /any other region/unit.



SPECIAL TERMS AND CONDITIONS

(Tender enquiry no. 2425-005E dated 18.04.2024 **Due date 30.04.2024**)

ITEM: HSFG Fasteners [Rate Contract]

3. In-case recoveries are not possible with any of the above available options, Legal action shall be initiated for recovery against defaulted supplier. Balance scope shall be got done independently without Risk & Cost of the failed supplier.

Further, levy of liquidated damages, debarment, termination, de-scoping, short-closure, etc., shall be applied as per provisions of the contract.

These Special terms and conditions and General Contract Conditions (GCC) collectively form the part of tender terms and conditions. Any term in special tender terms and conditions will supersede the GCC.



General Conditions of Contract (GCC) of MM Tenders

BHARAT HEAVY ELECTRICALS LIMITED

Industrial Valve Plant: 433, Industrial Complex,
Goindwal Sahib, Dist. Tarn Taran,
Punjab-143422 (INDIA)

TABLE OF CONTENTS

1. Instruction to Bidder	2
2. Scope of Supply	2
3. Price Basis.....	3
4. Performance Security (PS).....	3
5. Breach of contract, Remedies and Termination.....	4
6. Evaluation in Case of More Than One L-1 Bidder.....	4
7. Reverse Auction.....	4
8. Conflict of Interest among Bidders / Agents	5
9. Validity of Offers.....	5
10. Supplied Material Adjustment.....	5
11. Delivery Schedule.....	6
12. Liquidated Damaged (LD).....	6
13. Acceptance of Material Supplied.....	6
14. Payment Terms	7
15. Taxes & Duties	7
16. Liability Under Reverse Charge (RCM).....	8
17. Access to Manufacturing Premises.....	8
18. Inspection.....	8
19. Warrantee and Corresponding Repair / Replacement of Goods.....	9
20. LOI (Letter of Intent).....	10
21. Sub-Contract	10
22. Discrepancy in Words and Figures	10
23. Force Majeure	10
24. Non-Disclosure Agreement	11
25. Clarifications.....	11
26. Preferences for Micro and Small Enterprises (MSEs).....	11
27. Preference to Make in India.....	12
28. Restrictions Under Rule 144(XI) of The General Financial Rules (GFR), 2017	12
29. Resolution of Disputes.....	14
30. Fraud Prevention Policy.....	15
31. Preventive Checks to Eliminate Suspected Cartel Formation	15
32. Suspension of Business Dealings with Suppliers / Contractors	16
33. General.....	16
Annexure-X.....	19
Appendix-I of Annexure-X.....	25
Appendix-II of Annexure-X	26
Appendix-III of Annexure-X	27

Signature Not Verified

Signed By: AMAN SHARMA

Location: BHEL, Goindwal

Signing Date: 04.12.2023





General Conditions of Contract (GCC) of MM Tenders

BHARAT HEAVY ELECTRICALS LIMITED

Industrial Valve Plant: 433, Industrial Complex,
Goindwal Sahib, Dist. Tarn Taran,
Punjab-143422 (INDIA)

1. Instruction to Bidder

Quotations shall be submitted before due date and time. Late offers are liable to be rejected, so please ensure to submit bid well within due date and time. Techno-commercial part will be opened on due date.

Based on evaluation of techno-commercial offers, Price bids of bidders who qualify from techno-commercial evaluation shall be opened. BHEL may decide to open the Price bid same day at 1700 hrs. If not opened on the same day, all qualifying bidders shall be notified for date of opening of Price bids by email/fax/post/courier/E-procurement system generated email.

1.1 Instruction to Bidder (In case of Non-E-Procurement / Paper/ Manual/ Hard Copy based tenders)

Sealed Tenders can be dropped in the tender box labeled as 'Tender box for MM contracts.' This tender box is located at the entrance of Admin block BHEL Goindwal. Quotations can also be submitted through e-mail at tendermm_ivp@bhel.in. Offers received in time shall be considered only when offers are complete in all respects. In case of bulky tenders, please handover quotation to tender issuing authority [Contact: 01859 224 615 / 628]. Bid can be sent to following address:

**BHEL, Industrial Valve Plant,
#433, Industrial Complex,
Goindwal Sahib, Distt. Tarn Taran,
Punjab-143422.**

1.2 Instruction to bidder (In case of E-Procurement)

1. Interested bidders / suppliers shall submit their offer through e-procurement mode at <https://eprocurebhel.co.in/>.
2. **Offers in any other mode will not be accepted.**
3. Procedure for submission of tender is available in the "Bidder Manual Kit" at e-tender portal <https://eprocurebhel.co.in/>.
4. In case of any difficulty faced while registering on BHEL's e-Procurement portal developed by NIC, queries may be addressed to 0120-4001002, 0120-4001005 and 0120-6277787; email: support-eproc@nic.in. These details are also available on 'Contact Us' page of the portal.
5. Before uploading scanned documents if any, the bidders shall sign on all the statements, documents, certificates uploaded by him, owning responsibility for their correctness / authenticity.
6. **Disclaimer clause:** Neither the Organization (Bharat Heavy Electricals Ltd.) nor the service provider is responsible for any failure of submission of bids due to failure of internet or other connectivity problems or reasons thereof.

2. Scope of Supply

Material shall be supplied as per the applicable latest Technical Delivery Conditions (TDC)/ Material Standard requirements/BPS/Drawing and other requirement as given in the Tender Enquiry. National & International material Standards shall have to be arranged by vendors themselves. Latest applicable revisions of standards/procedures to be referred.

Signature Not Verified
Signed By: AMAN SHARMA
Location: BHEL Goindwal
Signing Date: 04.12.2023





General Conditions of Contract (GCC) of MM Tenders

BHARAT HEAVY ELECTRICALS LIMITED

Industrial Valve Plant: 433, Industrial Complex,
Goindwal Sahib, Dist. Tarn Taran,
Punjab-143422 (INDIA)

All required tests as called in referred material standard/BHEL/TDC/drawing etc. shall be carried out by vendor at no extra cost. Material Test Certificates (MTC), inspection reports and Compliance/Guarantee Certificate are to be provided along with the supplies.

3. Price Basis

1. Order of enquiry item sl. no. shall be maintained in the quotation.
2. The rates quoted shall be firm and fixed. No price variation is proposed and allowed.
3. Rates quoted should be FOR BHEL Goindwal basis. The offers quoted on other than FOR Goindwal basis are liable to be rejected.

In case bidder has quoted Ex-works prices, then he/she will be given an opportunity to accept price basis as FOR Goindwal either by accepting delivery as FOR Goindwal in same quoted price or by providing loading factor on his/her quoted ex-works prices to make them FOR prices.

Variation in GST or any other statutory levies during contractual delivery period shall be to BHEL's account.

4. Performance Security (PS)

Applicability:

- 1) Performance Security will not be applicable in which total PO value on vendor in one tender enquiry is less than or equal to Rupees one lakh.
- 2) **In case total PO value on vendor in one tender enquiry is greater than Rs. 1 Lakh:** Successful bidder (L1 or counter-offer accepted) has to submit Performance Security (PS) @5% of PO value within 21 days from the date of award of PO. PS shall be valid for a period of one year. This PS will be released to the vendor without interest after two months beyond the completion of all supplies under the PO.

Before the release of this PS, vendor has to submit another PS @1% of PO value or Rs. 3000.00 whichever is higher after two months beyond the completion of all supplies under the PO. This PS shall be valid for a period of 18 months. This additional PS will be released to the vendor without interest after expiry of validity upon fulfilment of contractual obligations as per terms of contract.

Vendor has to submit written request to BHEL for refund of PS well in advance before the due date.

In case of non-submission of PS for 5% of contract value, it will amount to breach of contract.

Mode of deposit:

Performance security may be furnished in the following forms:

- 1) Local cheques of Scheduled Banks (subject to realization)/ Pay Order/ Demand Draft/ Electronic Fund Transfer in favour of BHEL.
- 2) Bank Guarantee from Scheduled Banks / Public Financial Institutions as defined in the Companies Act. The Bank Guarantee format should have the approval of BHEL.
- 3) Fixed Deposit Receipt issued by Scheduled Banks / Public Financial Institutions as defined in the Companies Act (FDR should be in the name of the Contractor, a/c BHEL).

Signature Not Verified

Signed By: AMAN SHARMA

Location: BHEL Goindwal

Signing Date: 04.12.2023





General Conditions of Contract (GCC) of MM Tenders

BHARAT HEAVY ELECTRICALS LIMITED

Industrial Valve Plant: 433, Industrial Complex,
Goindwal Sahib, Dist. Tarn Taran,
Punjab-143422 (INDIA)

- 4) Securities available from Indian Post offices such as National Savings Certificates, Kisan Vikas Patras etc. (held in the name of Contractor furnishing the security and duly endorsed/hypothecated/ pledged, as applicable, in favour of BHEL).
- 5) Insurance Surety Bond.
- 6) By way of retention from dues available in the form of Bills payable to the supplier against same / other contracts in the same unit.

(Note: BHEL will not be liable or responsible in any manner for the collection of interest or renewal of the documents or in any other matter connected therewith).

Forfeiture of Performance Security:

The performance security will be forfeited and credited to BHEL's account in the event of a breach of contract by the supplier.

5. Breach of contract, Remedies and Termination

In case of breach of contract, wherever the value of security instruments like performance bank guarantee available with BHEL against the said contract is 10% of the contract value or more, such security instruments to the extent of 10% contract value will be encashed. In case the value of the security instruments available is less than 10% of the contract value, the balance amount be recovered in all or any of the following manners:

- from dues available in the form of Bills payable to defaulted supplier against the same contract.
- from the dues payable to defaulted supplier against other contracts in the same Region/Unit /any other region/unit.
- In-case recoveries are not possible with any of the above available options, Legal action shall be initiated for recovery against defaulted supplier.

Further, levy of liquidated damages, debarment, termination, de-scoping, short-closure, etc., shall be applied as per provisions of the contract.

6. Evaluation in Case of More Than One L-1 Bidder

In the course of evaluation, if more than one bidder happens to occupy L1 status, effective L1 will be decided by soliciting discounts from the respective L1 bidders.

In case more than one bidder happens to occupy the L1 status even after soliciting discounts, the L1 bidder shall be decided by a toss / draw of lots, in the presence of the respective L1 bidder(s) or their representative(s).

Ranking will be done accordingly. BHEL's decision in such situations shall be final and binding.

7. Reverse Auction

In case, it is declared in special terms & conditions of tender enquiry that RA is applicable for the NIT, then RA will be conducted as per following clause:

BHEL shall be resorting to Reverse Auction (RA) (Guidelines as available on <https://www.bhel.com/>) for this tender. RA shall be conducted among the techno-commercially qualified bidders as per RA guidelines.

Price bids of all techno-commercially qualified bidders shall be opened and same shall be considered

Signature Not Verified
Signed By: AMAN SHARMA
Location: BHEL, Goindwal
Signing Date: 04.12.2023





General Conditions of Contract (GCC) of MM Tenders

BHARAT HEAVY ELECTRICALS LIMITED

Industrial Valve Plant: 433, Industrial Complex,
Goindwal Sahib, Dist. Tarn Taran,
Punjab-143422 (INDIA)

for RA. In case any bidder(s) do(es) not participate in online Reverse Auction, their sealed envelope price bid along with applicable loading, if any, shall be considered for ranking.

8. Conflict of Interest among Bidders / Agents

A bidder shall not have conflict of interest with other bidders. Such conflict of interest can lead to anti-competitive practices to the detriment of Procuring Entity's interests. ***The bidder found to have a conflict of interest shall be disqualified.*** A bidder may be considered to have a conflict of interest with one or more parties in this bidding process, if:

- a) they have controlling partner (s) in common; **or**
- b) they receive or have received any direct or indirect subsidy/ financial stake from any of them; **or**
- c) they have the same legal representative/agent for purposes of this bid; **or**
- d) they have relationship with each other, directly or through common third parties, that puts them in a position to have access to information about or influence on the bid of another Bidder; **or**
- e) Bidder participates in more than one bid in this bidding process. Participation by a Bidder in more than one Bid will result in the disqualification of all bids in which the parties are involved. However, this does not limit the inclusion of the components/ sub-assembly/ Assemblies from one bidding manufacturer in more than one bid. **or**
- f) In cases of agents quoting in offshore procurements, on behalf of their principal manufacturers, one agent cannot represent two manufacturers or quote on their behalf in a particular tender enquiry. One manufacturer can also authorise only one agent/dealer. There can be only one bid from the following:
 1. The principal manufacturer directly or through one Indian agent on his behalf; and
 2. Indian/foreign agent on behalf of only one principal.**or**
- g) a Bidder or any of its affiliates participated as a consultant in the preparation of the design or technical specifications of the contract that is the subject of the Bid; **or**
- h) In case of a holding company having more than one independently manufacturing units, or more than one unit having common business ownership/management, only one unit should quote. Similar restrictions would apply to closely related sister companies. Bidders must proactively declare such sister/ common business/ management units in same/ similar line of business.

9. Validity of Offers

The offers shall be kept open for acceptance 'for number of days mentioned in special terms and conditions' from the date of opening of the tender. In case of tender extension, the bid validity shall be considered from the date of tender opening.

10. Supplied Material Adjustment

Item/s pending in previous PO has to be billed in previous PO only. Otherwise, BHEL will be free to adjust the supplies in previous PO. Any implication of tax will be on supplier's account. For this it is desirable that vendor should reconcile the pending PO statement every month/frequently with BHEL. Vendor can also view these details at Portal (<https://trichy.bhel.com/mm/index.jsp>).

Signature Not Verified
Signed By: AMAN SHARMA
Location: BHEL Goindwal
Signing Date: 04.12.2023





General Conditions of Contract (GCC) of MM Tenders

BHARAT HEAVY ELECTRICALS LIMITED

Industrial Valve Plant: 433, Industrial Complex,
Goindwal Sahib, Dist. Tarn Taran,
Punjab-143422 (INDIA)

11. Delivery Schedule

Supplies shall be affected and completed as per schedule mentioned in special terms and conditions. Commencement of delivery period shall be reckoned from the date of PO / LOI or any other agreed milestone.

12. Liquidated Damaged (LD)

- a) Time is the essence of the contract.
- b) The ordered items shall be delivered as per the delivery period mentioned in the Purchase Order.
- c) In case the supplier supplies the ordered items beyond the delivery period specified, Liquidated Damages -LD - as detailed below shall be levied from the supplier without prejudice to any other relief /compensation available to BHEL, Punjab under any other condition of the contract/applicable legal provisions.
- d) Failure to dispatch the materials in the time as per the delivery mentioned in our Purchase Order (PO) would make the supplier liable to an un-conditional LD at the rate of 0.5% of the undelivered order value per week of the delay or part thereof subject to a maximum of 10% of the undelivered order value.
- e) Any deviation from the above LD clause, loading will be applied to the extent to which it is not agreed by the bidder (at offered value).
- f) Indigenous: In case of Ex-works delivery terms, the document date (Invoice/Challan date) in Goods Receipt (GR) document shall be reckoned for LD deduction. In case of FOR Delivery terms, the posting date in GR document shall be reckoned for LD deduction.
- g) Import: For CFR terms, BL date will be considered for LD calculation.

BHEL reserves the right to receive or not receive the material after the due date of PO. Applicable GST shall also be recovered from suppliers/contractors on LD amount. For this Debit note will be issued by BHEL indicating the respective supply invoice number.

13. Acceptance of Material Supplied

1. The supply shall strictly as per the specifications in the tender /purchase order.
2. Delivery of the ordered items as per the delivery terms in the Purchase Order does not automatically constitute acceptance of the delivered items.
3. Acceptance of the materials supplied will be based on the inspection and certification documents by the supplier as stipulated in the Purchase order. However, BHEL reserves the right to test the material supplied, if required, at BHEL Lab or any other approved/accredited lab and the result will be binding on the supplier.
4. The acceptance or otherwise of the delivered items will be separately communicated to the supplier by BHEL through B2B portal within 15 days from the delivery of items or delivery of the required test certificates /other documents whichever is later.
5. In case of rejection of the delivered items, either part or full, the vendor shall replace the rejected items as per the specification in the Purchase order/tender at their cost within 30 days of communication of rejection to the supplier. The supplier shall be given maximum two opportunities to replace the rejected items.
6. After the clearance of the 1st lot, in case of rejection of the delivered items, either part or full, if the supplier fails to replace the rejected items within 30 days of communication of the rejection, the same shall be treated as failure to execute the contract and actions as per the Guidelines for

Signature Not Verified
Signed By: AMAN SHARMA
Location: BHEL Goindwal
Signing Date: 04.12.2023





General Conditions of Contract (GCC) of MM Tenders

BHARAT HEAVY ELECTRICALS LIMITED

Industrial Valve Plant: 433, Industrial Complex,
Goindwal Sahib, Dist. Tarn Taran,
Punjab-143422 (INDIA)

Suspension of Business Dealings with Suppliers /Contractors available in the webpage: <https://www.bhel.com> would be taken against such supplier.

14. Payment Terms

1. Payments shall be made to the Seller within the mentioned days (as per below table) from the date of receipt and acceptance of material.

Type of Bidder	Payment Terms (Number of days)
Micro & Small Enterprises (MSEs)	45 days
Medium Enterprises	60 days
Non MSME	90 days

To be considered as Micro, Small or Medium enterprise, bidder must be manufacturer of offer product and relevant valid certificate as per latest MSME guidelines is to be submitted along with bid.

MSME bidders can avail benefits of payment through TReDS (Trade Receivable e Discounting System).

In case of any deviation from standard payment term mentioned above, BHEL shall load on the item price at 'Base rate of SBI (as applicable on the date of bid opening; Techno-commercial bid opening) + 6% for the period of relaxation sought by bidders.

2. Documents to be submitted (if applicable)
 - i) Tax invoice (Invoice shall be GST compliant and should contains all the required information such as GST No, HSN code etc.)
 - ii) Transporter copy along with material/consignment.
 - iii) Material Test Certificates (MTC) and
 - iv) Compliance Certificate.
3. GST registration number is to be submitted by qualified vendor as per GST law.
4. It is mandatory to mention proper material codes in the invoices and separate invoices to be raised for different POs.
5. **BHEL releases payment through EFT mode ONLY. Necessary details may please be submitted by filling required format before release of payment.**

15. Taxes & Duties

Payment of GST portion will be released to vendor only upon completion of statutory requirement and further subject to following:

- a) Vendor declaring such invoice in his GSTR-1 and
- b) Receipt of goods and Tax invoice by BHEL and
- c) Confirmation of payment of GST thereon by vendor on GSTN portal.
- d) Above is subject to receipt of goods/service and tax invoice thereof along with vendor declaring invoice in his return and paying GST within timeline prescribed for availing ITC by BHEL.

Following may please be noted for availing Input Tax Credit (ITC) by BHEL:

Signature Not Verified
Signed By: AMAN SHARMA
Location: BHEL, Goindwal
Signing Date: 04.12.2023





General Conditions of Contract (GCC) of MM Tenders

BHARAT HEAVY ELECTRICALS LIMITED

Industrial Valve Plant: 433, Industrial Complex,
Goindwal Sahib, Dist. Tarn Taran,
Punjab-143422 (INDIA)

1. Since ITC can be availed only when BHEL is in possession of GST Tax invoice and after receipt of goods. Thus, vendor to ensure timely dispatch of goods and Tax invoice. It may be noted that in case of any delay in receipt of Tax Invoice and/or receipt of goods, the ITC availment by BHEL will get delayed thus entailing additional cash outflow & may even get denied if ITC availment timelines are breached.
2. Further ITC can be availed only when vendor has declared such invoice in his outward supply Return GSTR-1 and after GST thereon has been paid by him at the time of filing of monthly Return.
3. If GST credit is delayed/denied to BHEL due to non/delayed receipt of goods and/or tax invoice or expiry of timeline prescribed in GST law for availing such ITC, or any other reasons not attributable to BHEL, GST amount shall be recoverable from vendor along with interest levied/leviable on BHEL.
4. Further, in case vendor delays declaring such invoice in his return and GST credit availed by BHEL is denied or reversed subsequently as per GST law, GST amount paid by BHEL towards such ITC reversal as per GST law shall be recoverable from vendor/contractor along with interest levied/leviable on BHEL.

16. Liability Under Reverse Charge (RCM)

Any GST liability arising on BHEL under Reverse Charge (RCM) before actual receipt of goods and/ or Invoice thereof would be subject to recovery of Interest leviable for the period between the date of such liability and actual date of eligibility of ITC based on receipt of goods, receipt of Invoices and other conditions specified in GST Law as applicable.

17. Access to Manufacturing Premises

While Purchase Orders placed on the vendor are under execution, authorized representatives of BHEL shall be allowed free access to the manufacturing facilities for the purpose of inspection or monitoring the progress of purchase orders. This access will also be extended to representatives of BHEL's customers accompanying the authorized representative/s of BHEL (which shall be intimated in advance), if our contractual requirements with our customers call for the same.

18. Inspection

1. The seller shall give adequate notice, of 1 week or as mutually agreed period, in writing to the Purchaser about the date and place at which the goods will be ready for inspection/ testing, as provided for in the contract.
2. Purchaser or his authorized representative shall be entitled to carry out inspection of material and workmanship/Surveillance Audit at Seller's premises or at his sub-contractor's premises at all reasonable times during execution of contract; Such inspection, examination and testing, if made, shall not absolve the Seller from his obligations under the contract. No additional charges shall be claimed for such inspections. Moreover, all required infrastructure (testing, tools etc) have to be arranged by supplier.
3. Any inspection carried out before supply by vendor/incoming stage at BHEL notwithstanding, if any defect/non-conformity is noted during processing, the same shall be attended/replaced by vendor at no extra cost.
4. BHEL representative from unit or CQ is authorized to carry out audits along with TPIA at vendor's works before clearing the items for dispatch.

Signature Not Verified

Signed By: AMAN SHARMA

Location: BHEL, Goindwal

Signing Date: 04.12.2023





General Conditions of Contract (GCC) of MM Tenders

BHARAT HEAVY ELECTRICALS LIMITED

Industrial Valve Plant: 433, Industrial Complex,
Goindwal Sahib, Dist. Tarn Taran,
Punjab-143422 (INDIA)

5. Necessary tooling including thread gauges etc. have to be arranged by vendor. Only in exceptional cases, based on BHEL discretions item/nature, BHEL may consider request to provide gauges if available with BHEL. But in no case this shall be linked with delivery of material.
6. In case of following points, visit charges to be paid to Third Party Inspection Agency (TPIA) shall be imposed as penalty on Supplier:
 - a) Nothing/NIL material is offered during Inspection (whilst physical visit of Inspection Engineer at Supplier's work) with respect to "Offered Quantity" mentioned in raised Inspection Call.
 - b) Lapses on the account of supplier has led to rejection of offered material (as per approved QAP/ Technical Specifications/ Other pertinent requirement), while carrying out Inspection.
 - c) Less Quantity/ Short Quantity is offered during Inspection (whilst physical visit of Inspection Engineer at Supplier's work) with respect to "Offered Quantity" mentioned in raised Inspection Call for any of the line(s) item, leading to re-visit of Inspection Engineer.

19. Warrantee and Corresponding Repair / Replacement of Goods

Goods shall comply with the specifications for material, workmanship and performance. Unless otherwise specified, vendor shall give a warrantee against design & manufacturing defects for a period of 18 months from the date of receipt. In case of non-acceptance of this term, bid shall be liable for rejection.

If the delivery is found non-compliant during the warranty period, leading to rejection, the Seller shall arrange free replacement / repair of goods, within one month from the date of intimation. Corresponding quantity shall be treated as unsupplied against respective purchase order till replacement is received at BHEL. In the event of the Seller's failure to comply, Purchaser may take action as appropriate, including repair / replenish rejected goods, at the cost of the seller as per contractual obligations.

All incidental charges like freight, insurance and customs duty in respect of return of defective items are to vendor's account only. BHEL will inform related invoice, quantity etc. to supplier. Supplier has to give advance intimation / plan (Transporter, Vehicle details) for the lifting of material. Further supplier has to provide requisite documents (such as Credit Note, e-Way Bill etc.) to lift the rejected material. Material should be lifted within one month from date of intimation. After one-month, BHEL will not be responsible for rejected material and BHEL shall have the right to dispose off such rejected material.

The defective parts and components shall be collected by your Indian agent or / authorized person, only after completing the replacement / repairs. If the supplier fails to replace / rectify the defective/ damaged items on free of cost within one month of reporting from our end, the same shall be treated as failure to execute the contract and actions as per the Guidelines for Suspension of Business Dealings with Suppliers /Contractors available in the webpage: <https://www.bhel.com> would be taken against such supplier without prejudice to the other remedies available to BHEL under the contract and law in this regard.





General Conditions of Contract (GCC) of MM Tenders

BHARAT HEAVY ELECTRICALS LIMITED

Industrial Valve Plant: 433, Industrial Complex,
Goindwal Sahib, Dist. Tarn Taran,
Punjab-143422 (INDIA)

20. LOI (Letter of Intent)

BHEL may issue LOI prior to the PO for any reason whatsoever. The LOI in such cases is to be treated as PO for all practical purposes and all the Terms & Conditions of the tender shall be applicable from the date of issue of LOI.

21. Sub-Contract

The purchase order or any part thereof shall not be sub-contracted, assigned or otherwise transferred without previously obtaining the BHEL's consent in writing.

22. Discrepancy in Words and Figures

1. If, in the price structure quoted for the required goods/ services/ works, there is discrepancy between the unit price and the total price (which is obtained by multiplying the unit price by the quantity}, the unit price shall prevail and the total price corrected accordingly, unless in the opinion of the purchaser there is an obvious misplacement of the decimal point in the unit price, in which case the total price as quoted shall govern and the unit price corrected accordingly.
2. If there is an error in a total corresponding to the addition or subtraction of subtotals, the subtotals shall prevail and the total shall be corrected; and
3. If there is a discrepancy between words and figures, the amount in words shall prevail, unless the amount expressed in words is related to an arithmetic error, in which case the amount in figures shall prevail subject of (a) and (b) above.
4. If there is such discrepancy in an offer, the same shall be conveyed to the bidder with target date upto which the bidder has to send his acceptance on the above lines and if the bidder does not agree to the decision of the purchaser, the bid is liable to be ignored.
5. Bids should be free from correction, overwriting, using corrective fluid, etc. Any interlineation, cutting, erasure or overwriting shall be valid only if they are attested under full signature(s) of person(s) signing the bid else shall be liable for rejection.
6. All overwriting/cutting, etc will be numbered by bid opening officials and announced during bid opening.

23. Force Majeure

1. Notwithstanding the provisions contained in other clauses, the supplier shall not be liable for imposition of any such sanction so long the delay and/or failure of the supplier in fulfilling its obligations under the contract is the result of an event of Force Majeure. For purposes of this clause, Force Majeure means an event beyond the control of the supplier and not involving the supplier's fault or negligence and which is not foreseeable and not brought about at the instance of the party claiming to be affected by such event and which has caused the non – performance or delay in performance. Such events may include, but are not restricted to, wars or revolutions, hostility, acts of public enemy, civil commotion, sabotage, fires, floods, explosions, epidemics, quarantine restrictions, strikes excluding by its employees, lockouts excluding by its management, freight embargoes and Acts of GOD.
2. If a Force Majeure situation arises, the supplier shall promptly notify the Purchaser/Consignee in writing of such conditions and the cause thereof within twenty-one days of occurrence of such event. Unless otherwise directed by the Purchaser/Consignee in writing, the supplier shall continue

Signature Not Verified
Signed By: AMAN SHARMA
Location: BHEL, Goindwal
Signing Date: 04.12.2023





General Conditions of Contract (GCC) of MM Tenders

BHARAT HEAVY ELECTRICALS LIMITED

Industrial Valve Plant: 433, Industrial Complex,
Goindwal Sahib, Dist. Tarn Taran,
Punjab-143422 (INDIA)

- to perform its obligations under the contract as far as reasonably practical, and shall seek all reasonable alternative means for performance not prevented by the Force Majeure event.
3. If the performance in whole or in part or any obligation under this contract is prevented or delayed by any reason of Force Majeure for a period exceeding sixty days, either party may at its option terminate the contract without any financial repercussion on either side.
 4. In case due to a Force Majeure event the Purchaser/Consignee is unable to fulfil its contractual commitment and responsibility, the Purchaser/Consignee will notify the supplier accordingly and subsequent actions taken on similar lines described in above sub-paragraphs.

24. Non-Disclosure Agreement

All Drawing and technical documents relating to the product or it's manufacture submitted by one party to the other, prior or subsequent to the formation of contract, shall remain property of the submitting party. Drawing, technical documents or other technical information received by one party, shall not without the consent of the other party, be used for any other purpose than that, for which they were provided. Such technical information shall not without the consent of the submitting party, otherwise be used or copied, reproduced, transmitted or communicated to a third party. Patterns supplied by BHEL will remain BHEL's property which shall be returned by the bidder on demand to BHEL. Bidder shall in no way share or use such intellectual property of BHEL to promote his own business with others. ***BHEL reserves the right to claim damages from the bidder, or take appropriate penal action as deemed fit against the bidder, for any infringement of the provisions contained herein.***

25. Clarifications

The correspondence exchanged against the tender from both tenderer and BHEL through email/e-procurement are considered as valid document legally though it is not signed. It is treated as valid confirmations made on behalf of the respective company and very much comes under the legal ambit of the business transaction and hence it is binding on both the parties to the business. Any transaction pertaining to the tender from both the parties of business done round the clock irrespective of the office or business hours of the companies, are valid legally and binding on both the parties. This applies to the extent only in such cases where deadline time for transaction is not specifically declared by either or both the parties to the business.

26. Preferences for Micro and Small Enterprises (MSEs)

Preferences as mentioned in “Public Procurement Policy for Micro and Small Enterprises (MSEs) Order, 2012” & “Public Procurement Policy for Micro and Small Enterprises (MSEs) Amendment Order, 2018”, or as per latest guidelines issued by government shall be given to Micro and Small enterprises.

Main points which are mentioned in the above orders are as follows:

- 25% Procurement of the tender value shall be made from MSE (Micro, Small Enterprises) firms.
- 25% of the 25% quantity (i.e. 6.25% of the tender quantity) offered to the MSE's shall be reserved for MSE's owned by SC/STs. Failure to participate by any MSE owned by SC/ST's; this 6.25% quantity shall be procured from other MSEs.

Signature Not Verified
Signed By: AMAN SHARMA
Location: BHEL, Goindwal
Signing Date: 04.12.2023





General Conditions of Contract (GCC) of MM Tenders

BHARAT HEAVY ELECTRICALS LIMITED

Industrial Valve Plant: 433, Industrial Complex,
Goindwal Sahib, Dist. Tarn Taran,
Punjab-143422 (INDIA)

- 3% from within the 25% quantity offered to the MSE's shall be reserved for women owned MSE's. Failure to participate by any MSE owned by women; this 3% quantity shall be procured from other MSEs.
- EMD shall be exempted for MSE's. All these benefits are subject to production of all statutory documents
- In tender, participating Micro and Small Enterprises quoting price within price band of L1+15 per cent shall also be allowed to supply a portion of requirement by bringing down their price to L1 price in a situation where L1 price is from someone other than a Micro and Small Enterprise and such Micro and Small Enterprise shall be allowed to supply up to 25 per cent of total tendered value. In case of more than one such Micro and Small Enterprise, the supply shall be shared proportionately (to tendered quantity).

MSE suppliers can avail the intended benefits only if they submit **Udyam Registration Certificate** along with the offer. No other document shall be considered for availing MSE benefits. Non-submission of such document will lead to consideration of their bid at par with other bidders. No benefit shall be applicable for this enquiry if any deficiency in the above required documents is not cleared before price bid opening. If the tender is to be submitted through e-procurement portal, then the above required document is to be uploaded on the portal.

Note: It may however be noted that MSE guidelines as on date (Date of Technical Bid Opening Part-1) shall prevail.

27. Preference to Make in India

This procurement shall be governed by notification no. P-45021/2/2017-PP (BE-II) dated 16.09.2020 of Government of India issued by DPIIT and subsequent circulars issued afterwards. Accordingly, the minimum local content, the margin of purchase preference and the procedure for purchase preference to make in India shall be adhered.

28. Restrictions Under Rule 144(XI) of The General Financial Rules (GFR), 2017

Restrictions on procurement from a bidder of a country which shares a land border with India

- a) Any bidder from a country which shares a land border with India will be eligible to bid in this tender, whether of goods or services (including consultancy services and non-consultancy services), only if the bidder is registered with the Competent Authority.
 - b) Further, any bidder (including an Indian bidder) who has a Specified Transfer of Technology (ToT) arrangement with an entity from a country which shares a land border with India will be eligible to bid in any procurement whether of goods or services (including consultancy services and non-consultancy services) only if the bidder is registered with the Competent Authority. *This clause shall be applicable only in the tenders which attract restrictions due to specified ToT.*
- II. "Bidder" (Seller / Service Provider) means any person or firm or company, including any member of a consortium or joint venture (that is an association of several persons, or firms or companies), every artificial juridical person not falling in any of the descriptions of bidders stated hereinbefore, including any agency branch or office controlled by such person, participating in a procurement process.

Signature Not Verified

Signed By: AMAN SHARMA
Location: BHEL, Goindwal
Signing Date: 04.12.2023





General Conditions of Contract (GCC) of MM Tenders

BHARAT HEAVY ELECTRICALS LIMITED

Industrial Valve Plant: 433, Industrial Complex,
Goindwal Sahib, Dist. Tarn Taran,
Punjab-143422 (INDIA)

- III. "Bidder (or entity) from a country which shares a land border with India" for the purpose of the Order means:
- An entity incorporated, established, or registered in such a country; or
 - A subsidiary of an entity incorporated, established, or registered in such a country; or
 - An entity substantially controlled through entities incorporated, established, or registered in such a country; or
 - An entity whose beneficial owner is situated in such a country; or
 - An Indian (or other) agent of such an entity; or
 - A natural person who is a citizen of such a country; or
 - A consortium or joint venture where any member of the consortium or joint venture falls under any of the above
- IV. The beneficial owner for the purpose of (iv) above will be as under
- In case of a company or Limited Liability Partnership, the beneficial owner is the natural person(s), who, whether acting alone or together, or through one or more juridical person, has a controlling ownership interest or who exercises control through other means.
Explanation—
 - "Controlling ownership interest" means ownership of or entitlement to more than twenty-five per cent. of shares or capital or profits of the company;
 - "Control" shall include the right to appoint majority of the directors or to control the management or policy decisions including by virtue of their shareholding or management rights or shareholders agreements or voting agreements;
 - In case of a partnership firm, the beneficial owner is the natural person(s) who, whether acting alone or together, or through one or more juridical person, has ownership of entitlement to more than fifteen percent of capital or profits of the partnership;
 - In case of an unincorporated association or body of individuals, the beneficial owner is the natural person(s), who, whether acting alone or together, or through one or more juridical person, has ownership of or entitlement to more than fifteen percent of the property or capital or profits of such association or body of individuals;
 - Where no natural person is identified under (1) or (2) or (3) above, the beneficial owner is the relevant natural person who holds the position of senior managing official;
 - In case of a trust, the identification of beneficial owner(s) shall include identification of the author of the trust, the trustee, the beneficiaries with fifteen percent or more interest in the trust and any other natural person exercising ultimate effective control over the trust through a chain of control or ownership.
- V. An Agent is a person employed to do any act for another, or to represent another in dealings with third person.
- VI. The registration shall be valid at the time of submission of bid and at the time of acceptance of bid.
- VII. If the bidder was validly registered at the time of acceptance / placement of order, registration shall not be a relevant consideration during contract execution.
- VIII. "Transfer of Technology" means dissemination and transfer of all forms of commercially usable knowledge such as transfer of know-how, skills, technical expertise, designs, processes and procedures, trade secrets, which enables the acquirer of such technology to perform activities using the transferred technology independently.

Signature Not Verified
Signed By: AMAN SHARMA
Location: BHEL, Goindwal
Signing Date: 04.12.2023





General Conditions of Contract (GCC) of MM Tenders

BHARAT HEAVY ELECTRICALS LIMITED

Industrial Valve Plant: 433, Industrial Complex,
Goindwal Sahib, Dist. Tarn Taran,
Punjab-143422 (INDIA)

Any false declaration and non-compliance of the above would be a ground for debarment and further legal action in accordance with law.

Bidder has to submit a certificate certifying following along with offer:

"I have read the clause regarding restrictions on procurement from a bidder of a country which shares a land border with India; I certify that this bidder is not from such a country or, if from such a country, has been registered with the Competent Authority. I hereby certify that this bidder fulfils all requirements in this regard and is eligible to be considered. [Where applicable, evidence of valid registration by the Competent Authority shall be Attached]."

29. Resolution of Disputes

The Parties agree that if at any time (whether before, during or after the arbitral or judicial proceedings), any Disputes (which term shall mean and include any dispute, difference, question or disagreement arising in connection with construction, meaning, operation, effect, interpretation or breach of the contract/tender which the Parties are unable to settle mutually), arise inter-se the Parties, the same may, be referred by either party to Conciliation to be conducted through Independent Experts Committee to be appointed by competent authority of BHEL from the BHEL Panel of Conciliators.

Notes:

1. No serving or a retired employee of BHEL/Administrative Ministry of BHEL shall be included in the BHEL Panel of Conciliators.
2. Any other person(s) can be appointed as Conciliator(s) who is/are mutually agreeable to both the parties from outside the BHEL Panel of Conciliators.

The proceedings of Conciliation shall broadly be governed by Part-III of the Arbitration and Conciliation Act 1996 or any statutory modification thereof and as provided in Annexure-X to this GCC.

The Annexure-X together with its appendices will be treated as if the same is part and parcel hereof and shall be as effectual as if set out herein in this GCC.

Except as provided elsewhere in this Contract, in case amicable settlement is not reached between the parties, in respect of any dispute or difference; arising out of the formation, breach, termination, validity or execution of the Contract; or, the respective rights and liabilities of the Parties; or, in relation to interpretation of any provision of the Contract; or, in any manner touching upon the Contract, then, either Party may, by a notice in writing to other Party, refer such dispute or difference to sole arbitration of an arbitrator appointed as per the Arbitration and Conciliation Act, 1996 (India) or statutory modification or re-enactment thereof and the rules made thereunder and for the time being in force.

The Arbitrator shall pass a reasoned award and the award of the Arbitrator shall be final and binding upon the parties.

This contract shall be governed, construed and interpreted in accordance with the laws of India.

Signature Not Verified
Signed By: AMAN SHARMA
Location: BHEL, Goindwal
Signing Date: 04.12.2023





General Conditions of Contract (GCC) of MM Tenders

BHARAT HEAVY ELECTRICALS LIMITED

Industrial Valve Plant: 433, Industrial Complex,
Goindwal Sahib, Dist. Tarn Taran,
Punjab-143422 (INDIA)

Subject as aforesaid, the provisions of Arbitration & Conciliation Act 1996 (India) or statutory modification or re-enactment thereof and the rules made thereunder and for the time being in force shall apply to the arbitration proceeding under this clause.

The seat of arbitration shall be Tarn Taran, Punjab, India.

The cost of arbitration shall be borne as per the award of the Arbitrator.

Subject to arbitration in terms of clause above, the Courts at Tarn Taran, Punjab, India shall have exclusive jurisdiction over any matter arising out of or in connection with this Contract.

Notwithstanding the existence or any dispute or difference and/or reference for the arbitration, the vendor/contractor shall proceed with and continue without hindrance the performance of its obligation under this Contract with due diligence and expedition in a professional manner except where the Contract has been terminated by either Party in terms of this Contract.

In Case of Contract with Public Sector Enterprise (PSE) or a Government Department, the following shall be applicable:

In the event of any dispute or difference relating to the interpretation and application of the provisions of commercial contract(s) between Central Public Sector Enterprises (CPSEs)/Port Trusts inter se and also between CPSEs and Government Departments/Organizations (Excluding disputes concerning Railways, Income Tax, Customs & Excise Departments, such dispute or difference shall be taken up by either party for its resolution through AMRCD as mentioned in DPE OM No.05/003/2019-FTS-10937 dated 14th December, 2022 and the decision of AMRCD on the said dispute will be binding on both the parties.”

Set off : BHEL shall have the right to recover any money which in the sole opinion of BHEL is due from the supplier from any money due to the supplier under this Contract or any other contract or from the Security Deposit/BG furnished by the supplier under this Contract or any other contract.

30. Fraud Prevention Policy

The Bidder along with its associate / collaborators / sub-contractors / sub-vendors / consultants / service providers shall strictly adhere to BHEL Fraud Prevention Policy displayed on BHEL website <https://www.bhel.com/> and shall immediately bring to the notice of BHEL management about any fraud or suspected fraud as soon as it comes to their notice.

31. Preventive Checks to Eliminate Suspected Cartel Formation

The Bidder declares that they will not enter into any illegal or undisclosed agreement or understanding, whether formal or informal with other Bidder(s). This applies in particular to prices, specifications, certifications, subsidiary contracts, submission or non-submission of bids or any other actions to restrict competitiveness or to introduce cartelization in the bidding process.





General Conditions of Contract (GCC) of MM Tenders

BHARAT HEAVY ELECTRICALS LIMITED

Industrial Valve Plant: 433, Industrial Complex,
Goindwal Sahib, Dist. Tarn Taran,
Punjab-143422 (INDIA)

In case, the Bidder is found having indulged in above activities, suitable action shall be taken by BHEL as per extant policies/ guidelines.

32. Suspension of Business Dealings with Suppliers / Contractors

The offers of the bidders who are under suspension as also the offers of the bidders, who engage the services of the firms debarred across BHEL, shall be rejected. The list of firms debarred across BHEL is available on BHEL web site <https://www.bhel.com/>.

INTEGRITY COMMITMENT, PERFORMANCE OF THE CONTRACT AND PUNITIVE ACTION THEREOF:

31.1. Commitment by BHEL:

BHEL commits to take all measures necessary to prevent corruption in connection with the tender process and execution of the contract. BHEL will during the tender process treat all Bidder(s) in a transparent and fair manner, and with equity.

31.2. Commitment by Bidder/ Supplier/ Contractor:

31.2.1. The bidder/ supplier/ contractor commits to take all measures to prevent corruption and will not directly or indirectly influence any decision or benefit which he is not legally entitled to nor will act or omit in any manner which tantamount to an offence punishable under any provision of the Indian Penal Code, 1860 or any other law in force in India.

31.2.2. The bidder/ supplier/ contractor will, when presenting his bid, disclose any and all payments he has made, and is committed to or intends to make to agents, brokers or any other intermediaries in connection with the award of the contract and shall adhere to relevant guidelines issued from time to time by Govt. of India/ BHEL.

31.2.3. The bidder/ supplier/ contractor will perform/ execute the contract as per the contract terms & conditions and will not default without any reasonable cause, which causes loss of business/ money/ reputation, to BHEL.

If any bidder/ supplier/ contractor during pre-tendering/ tendering/ post tendering/ award/ execution/ post-execution stage indulges in mal-practices, cheating, bribery, fraud or and other misconduct or formation of cartel so as to influence the bidding process or influence the price or acts or omits in any manner which tantamount to an offence punishable under any provision of the Indian Penal Code, 1860 or any other law in force in India, then, action may be taken against such bidder/ supplier/ contractor as per extant guidelines of the company available on <https://www.bhel.com/> and/or under applicable legal provisions

33. General

1. BHEL will not be bound by any power of attorney granted by the vendors or by changes in the composition of the firm made subsequent to the execution of the contract. They may, however,

Signature Not Verified

Signed By: AMAN SHARMA

Location: BHEL, Goindwal

Signing Date: 04.12.2023





General Conditions of Contract (GCC) of MM Tenders

BHARAT HEAVY ELECTRICALS LIMITED

Industrial Valve Plant: 433, Industrial Complex,
Goindwal Sahib, Dist. Tarn Taran,
Punjab-143422 (INDIA)

- recognize such power of attorney and changes after obtaining proper legal advice, the cost of which will be chargeable to the vendor concerned.
2. BHEL reserves the right to extend the due date of opening, which shall be informed. Validity of offer shall be deemed to be revised accordingly.
 3. BHEL reserves the right to accept or reject any part or whole of the tender of a bidder by assigning a valid reason thereof. BHEL reserves the right to cancel the tender without assigning any reason thereof and without any obligation before any commitment.
 4. Acceptance of all terms and conditions, in the form of signed copy of T&C or confirmation separately written, shall be submitted along with quotation. If nothing is mentioned, it shall be concluded that these terms and conditions are acceptable.
 5. BHEL may increase/decrease item/s based on BHEL requirement before price bid opening. Suitable price implication may be asked from suppliers.
 6. BHEL may drop item/items from tender at any stage of tender before placing PO. BHEL may also delete PO with consent with supplier within delivery date of PO.
 7. After releasing PO, it is assumed that supplier has accepted PO if we do not receive acknowledgement from supplier within 5 days of date of PO.
 8. In case of unscheduled holiday on opening day of tender, the next working day will be treated as scheduled prescribed day of opening of tender.
 9. On the due date of tender opening, only technical bids will be opened. The opened technical bids will be evaluated by us and clarifications required, if any, will be called for from the bidders on technical and commercial points. If no reply is received from the vendor for the clarification raised by BHEL within the final cut-off date, those vendors offer will be processed with the documents available / submitted against this tender. Offers not meeting the required specification and technical condition will be summarily rejected. The price bids of technically suitable bidders will be opened on a later date with prior intimation to techno-commercially suitable bidders.
 10. Ranking L-1, L-2 etc. shall be done for individual item for the techno-commercially acceptable offers on landed cost to BHEL, IVP Goindwal basis and BHEL reserves the right to place order for individual items with different vendors.
 11. BHEL reserves the right to negotiate with L1 vendor or re-float the tender for items where, L1 price is not the lowest acceptable price; BHEL reserves the right to increase or decrease the tender quantity.
 12. If supplier is mentioning delivery destination within state/ outside state depending upon his location of factory, Free on Road etc. these are assumed as on FOR Goindwal. If supplier is wishing to give delivery on Ex works basis, then he has to clearly mention about it.
 13. The bidder has to keep track of any changes by viewing the addendum(s) / Corrigendum(s) issued by the Purchaser on time-to- time basis in the E-Procurement platform. The Company calling for tenders shall not be responsible for any claims/problems arising out of this.
 14. Unregistered suppliers, who are techno-commercially qualified against the open tender, are requested to register with BHEL as permanent supplier by submitting the Supplier Registration Form (SRF) in online supplier registration portal (<https://supplier.bhel.in/>).
 15. The General Conditions of Contract and the Special Conditions in each enquiry and the resulting purchase order constitute the entire contract between the parties. In case of any discrepancy between the provisions of General Conditions of Contract and Special Conditions of the Tender,

Signature Not Verified

Signed By: AMAN SHARMA

Location: BHEL, Goindwal

Signing Date: 04.12.2023





General Conditions of Contract (GCC) of MM Tenders
BHARAT HEAVY ELECTRICALS LIMITED

Industrial Valve Plant: 433, Industrial Complex,
Goindwal Sahib, Dist. Tarn Taran,
Punjab-143422 (INDIA)

the provisions in Special Conditions of the Tender shall prevail and interpretation of BHEL of such condition/clause will be final and binding on both the parties ..





General Conditions of Contract (GCC) of MM Tenders

BHARAT HEAVY ELECTRICALS LIMITED

Industrial Valve Plant: 433, Industrial Complex,
Goindwal Sahib, Dist. Tarn Taran,
Punjab-143422 (INDIA)

Annexure-X

BRIEF PROCEDURE FOR CONDUCT OF CONCILIATION PROCEEDINGS

1. The proceedings of Conciliation shall broadly be governed by Part-III of the Arbitration and Conciliation Act 1996 or any statutory modification thereof and as provided herein:
2. The party desirous of resorting to Conciliation shall send an invitation/notice in writing to the other party to conciliate specifying all points of Disputes with details of the amount claimed. The party concerned shall not raise any new issue thereafter. Parties shall also not claim any interest on claims/counter-claims from the date of notice invoking Conciliation till the conclusion of the Conciliation proceedings.
3. The party receiving the invitation/notice for Conciliation shall within 30 days of receipt of the notice of Conciliation intimate its consent for Conciliation along with its counter-claims, if any.
4. The Conciliation in a matter involving claim or counter-claim (whichever is higher) up to Rs 5 crores shall be carried out by sole Conciliator nominated by BHEL while in a matter involving claim or counter-claim (whichever is higher) of more than Rs 5 crores Conciliation shall be carried out by 3 Conciliators nominated by BHEL.
5. The Parties shall be represented by only their duly authorized in-house executives/officers and neither Party shall be represented by a Lawyer.
6. The first meeting of the IEC shall be convened by the IEC by sending appropriate communication/notice to both the parties as soon as possible but not later than 30 days from the date of his/their appointment. The hearings in the Conciliation proceeding shall ordinarily be concluded within two (2) months and, in exceptional cases where parties have expressed willingness to settle the matter or there exists possibility of settlement in the matter, the proceedings may be extended by the IEC by a maximum of further 2 months with the consent of the Parties subject to cogent reasons being recorded in writing.
7. The IEC shall thereafter formulate recommendations for settlement of the Disputes supported by reasons at the earliest but in any case, within 15 days from the date of conclusion of the last hearing. The recommendations so formulated along with the reasons shall be furnished by the IEC to both the Parties at the earliest but in any case, within 1 month from the date of conclusion of the last hearing.
8. Response/modifications/suggestions of the Parties on the recommendations of the IEC are to be submitted to the IEC within time limit stipulated by the IEC but not more than 15 days from the date of receipt of the recommendations from the IEC.
9. In the event, upon consideration, further review of the recommendations is considered necessary, whether by BHEL or by the other Party, then, the matter can be remitted back to the IEC with

Signature Not Verified
Signed By: AMAN SHARMA
Location: BHEL, Goindwal
Signing Date: 04.12.2023





General Conditions of Contract (GCC) of MM Tenders

BHARAT HEAVY ELECTRICALS LIMITED

Industrial Valve Plant: 433, Industrial Complex,
Goindwal Sahib, Dist. Tarn Taran,
Punjab-143422 (INDIA)

- request to reconsider the same in light of the issues projected by either/both the Parties and to submit its recommendations thereon within the following 15 days from the date of remitting of the case by either of the Parties.
10. Upon the recommendations by the Parties, with or without modifications, as considered necessary, the IEC shall be called upon to draw up the Draft Settlement Agreement in terms of the recommendations.
 11. When a consensus can be arrived at between the parties only in regard to any one or some of the issues referred for Conciliation the draft Settlement Agreement shall be accordingly formulated in regard to the said Issue(s), and the said Settlement Agreement, if signed, by the parties, shall be valid only for the said issues. As regards the balance issues not settled, the parties may seek to resolve them further as per terms and conditions provided in the contract.
 12. In case no settlement can be reached between the parties, the IEC shall by a written declaration, pronounce that the Conciliation between the parties has failed and is accordingly terminated.
 13. Unless the Conciliation proceedings are terminated in terms of para 22 (b), (c) & (d) herein below, the IEC shall forward his/its recommendations as to possible terms of settlement within one (1) month from the date of last hearing. The date of first hearing of Conciliation shall be the starting date for calculating the period of 2 months.
 14. In case of 3 members IEC, 2 members of IEC present will constitute a valid quorum for IEC and meeting can take place to proceed in the matter after seeking consent from the member who is not available. If necessary, videoconferencing may be arranged for facilitating participation of the members. However, the IEC recommendations will be signed by all members. Where there is more than one (1) Conciliator, as a general rule they shall act jointly. In the event of differences between the Members of IEC, the decision/recommendations of the majority of the Members of IEC shall prevail and be construed as the recommendation of the IEC.
 15. The Draft Settlement Agreement prepared by the IEC in terms of the consensus arrived at during the Conciliation proceedings between the Parties shall be given by the IEC to both the parties for putting up for approval of their respective Competent Authority.
 16. Before submitting the draft settlement agreement to BHEL's Competent Authority viz. the Board Level Committee on Alternative Dispute Resolution (BLCADR) for approval, concurrence of the other party's Competent Authority to the draft settlement agreement shall be obtained by the other party and informed to BHEL within 15 days of receipt of the final draft settlement agreement by it. Upon approval by the Competent Authority, the Settlement Agreement would thereafter be signed by the authorized representatives of both the Parties and authenticated by the members of the IEC.
 17. In case the Draft Settlement Agreement is rejected by the Competent Authority of BHEL or the other Party, the Conciliation proceedings would stand terminated.

Signature Not Verified
Signed By: AMAN SHARMA
Location: BHEL, Goindwal
Signing Date: 04.12.2023





General Conditions of Contract (GCC) of MM Tenders

BHARAT HEAVY ELECTRICALS LIMITED

Industrial Valve Plant: 433, Industrial Complex,
Goindwal Sahib, Dist. Tarn Taran,
Punjab-143422 (INDIA)

18. A Settlement Agreement shall contain a statement to the effect that each of the person(s) signing thereto (i) is fully authorized by the respective Party(ies) he/she represents, (ii) has fully understood the contents of the same and (iii) is signing on the same out of complete freewill and consent, without any pressure, undue influence.
19. The Settlement Agreement shall thereafter have the same legal status and effect as an arbitration award on agreed terms on the substance of the dispute rendered by an arbitral tribunal passed under section 30 of the Arbitration and Conciliation Act, 1996.
20. Acceptance of the Draft Settlement Agreement/recommendations of the Conciliator and/or signing of the Settlement Agreement by BHEL shall however, be subject to withdrawal/closure of any arbitral and/or judicial proceedings initiated by the concerned Party in regard to such settled issues.
21. Unless otherwise provided for in the agreement, contract or the Memorandum of Understanding, as the case may be, in the event of likelihood of prolonged absence of the Conciliator or any member of IEC, for any reason/incapacity, the Competent Authority/Head of Unit/Division/Region/Business Group of BHEL may substitute the Conciliator or such member at any stage of the proceedings. Upon appointment of the substitute Conciliator(s), such reconstituted IEC may, with the consent of the Parties, proceed with further Conciliation into the matter either de-novo or from the stage already reached by the previous IEC before the substitution.
22. The proceedings of Conciliation under this Scheme may be terminated as follows:
- On the date of signing of the Settlement agreement by the Parties; or,
 - By a written declaration of the IEC, after consultation with the parties, to the effect that further efforts at conciliation are no longer justified, on the date of the declaration; or,
 - By a written declaration of the Parties addressed to the IEC to the effect that the Conciliation proceedings are terminated, on the date of the declaration; or,
 - By a written declaration of a Party to the other Party and the IEC, if appointed, to the effect that the Conciliation proceedings are terminated, on the date of the declaration.
 - On rejection of the Draft Settlement Agreement by the Competent Authority of BHEL or the other Party.

Signature Not Verified
Signed By: AMAN SHARMA
Location: BHEL Goindwal
Signing Date: 04.12.2023





General Conditions of Contract (GCC) of MM Tenders

BHARAT HEAVY ELECTRICALS LIMITED

Industrial Valve Plant: 433, Industrial Complex,
Goindwal Sahib, Dist. Tarn Taran,
Punjab-143422 (INDIA)

23. The Conciliator(s) shall be entitled to following fees and facilities:

Sr. No.	Particulars	Amount
1	Sitting fees	Each Member shall be paid a Lump Sum fee of Rs 75,000/- for the whole case payable in terms of paragraph No. 27 herein below.
2	Towards drafting of settlement agreement	<p>In cases involving claim and/or counter-claim of up to Rs 5crores. Rs 50,000/- (Sole Conciliator)</p> <p>In cases involving claim and/or counter-claim of exceeding Rs 5 crores but less than Rs 10 crores. Rs. 75,000 (per Conciliator)</p> <p>In cases involving claim and/or counter-claim of more than Rs 10 crores. Rs 1,00,000/- (per Conciliator)</p> <p>Note: The aforesaid fees for the drafting of the Settlement Agreement shall be paid on Signing of the Settlement Agreement after approval of the Competent Authority or Rejection of the proposed Settlement Agreement by the Competent Authority of BHEL.</p>
3	Secretarial expenses	<p>Rs 10,000/- (one time) for the whole case for Conciliation by a Sole Member IEC.</p> <p>Where Conciliation is by multi member Conciliators –Rs 30,000/- (one time)- to be paid to the IEC</p>
4	Travel and transportation and stay at outstation	As per entitlement of the equivalent officer (pay scale wise) in BHEL.
	i Retired Senior Officials of other Public Sector Undertakings (pay scale wise equivalent to or more than E-8 level of BHEL)	
	Others	As per the extant entitlement of whole time Functional Directors in BHEL.

Signature Not Verified

Signed By: AMAN SHARMA

Location: BHEL, Goindwal

Signing Date: 04.12.2023





General Conditions of Contract (GCC) of MM Tenders BHARAT HEAVY ELECTRICALS LIMITED

Industrial Valve Plant: 433, Industrial Complex,
Goindwal Sahib, Dist. Tarn Taran,
Punjab-143422 (INDIA)

5	Venue for meeting	Unless otherwise agreed in the agreement, contract or the Memorandum of Understanding, as the case may be, the venue/seat of proceedings shall be the location of the concerned Unit / Division / Region / Business Group of BHEL. Without prejudice to the seat/venue of the Conciliation being at the location of concerned BHEL Unit / Division / Region / Business Group, the IEC after consulting the Parties may decide to hold the proceedings at any other place/venue to facilitate the proceedings. Unless, Parties agree to conduct Conciliation at BHEL premises, the venue is to be arranged by either Party alternately.
---	-------------------	--

24. The parties will bear their own costs including cost of presenting their cases/evidence/witness(es)/expert(s) on their behalf. The parties agree to rely upon documentary evidence in support of their claims and not to bring any oral evidence in IEC proceedings.

25. If any witness(es) or expert(s) is/are, with the consent of the parties, called upon to appear at the instance of the IEC in connection with the matter, then, the costs towards such witness(es)/expert(s) shall be determined by the IEC with the consent of the Parties and the cost so determined shall be borne equally by the Parties.

26. The other expenditures/costs in connection with the Conciliation proceedings as well as the IEC's fees and expenses shall be shared by the Parties equally.

27. Out of the lump sum fees of Rs 75,000/- for Sitting Fees, 50% shall be payable after the first meeting of the IEC and the remaining 50% of the Sitting Fees shall be payable only after termination of the conciliation proceedings in terms of para 22 hereinabove.

28. The travelling, transportation and stay at outstation shall be arranged by concerned Unit as per entitlements as per Serial No. 3 of the Table at para 23 above, and in case such arrangements are not made by the BHEL Unit, the same shall be reimbursed to the IEC on actuals limited to their entitlement as per Serial No. 4 of the Table at Para 23 above against supporting documents. The IEC Member(s) shall submit necessary invoice for claiming the fees/reimbursements.

29. The Parties shall keep confidential all matters relating to the conciliation proceedings. Confidentiality shall extend also to the settlement agreement, except where its disclosure is necessary for purposes of its implementation and enforcement or as required by or under a law or as per directions of a Court/Governmental authority/ regulatory body, as the case may be.

30. The Parties shall not rely upon or introduce as evidence in any further arbitral or judicial proceedings, whether or not such proceedings relate to the Disputes that is the subject of the Conciliation proceedings:

Signature Not Verified
Signed By: AMAN SHARMA
Location: BHEL, Goindwal
Signing Date: 04.12.2023





General Conditions of Contract (GCC) of MM Tenders

BHARAT HEAVY ELECTRICALS LIMITED

Industrial Valve Plant: 433, Industrial Complex,
Goindwal Sahib, Dist. Tarn Taran,
Punjab-143422 (INDIA)

- a. Views expressed or suggestions made by the other party in respect of a possible settlement of the Disputes;
- b. admissions made by the other party in the course of the Conciliator proceedings;
- c. proposals made by the Conciliator;
- d. The fact that the other Party had indicated his willingness to accept a proposal for settlement made by the Conciliator.

31. The Parties shall not present the Conciliator(s) as witness in any Alternative Dispute Resolution or Judicial proceedings in respect of a Disputes that is/was the subject of that particular Conciliation proceeding.

32. None of the Conciliators shall act as an arbitrator or as a representative or counsel of a Party in any arbitral or judicial proceeding in respect of a Disputes that is/was the subject of that particular Conciliation proceeding.

33. The Parties shall not initiate, during the Conciliation proceedings, any arbitral or judicial proceedings in respect of a Disputes that is the subject matter of the Conciliation proceedings except that a Party may initiate arbitral or judicial proceedings where, in his opinion, such proceedings are necessary for preserving his rights including for preventing expiry of period of limitation. Unless terminated as per the provisions of this Scheme, the Conciliation proceedings shall continue notwithstanding the commencement of the arbitral or judicial proceedings and the arbitral or judicial proceedings shall be primarily for the purpose of preserving rights including preventing expiry of period of limitation.

34. The official language of Conciliation proceedings under this Scheme shall be English unless the Parties agree to some other language.





General Conditions of Contract (GCC) of MM Tenders

BHARAT HEAVY ELECTRICALS LIMITED

Industrial Valve Plant: 433, Industrial Complex,
Goindwal Sahib, Dist. Tarn Taran,
Punjab-143422 (INDIA)

Appendix-I of Annexure-X

FORMAT FOR SEEKING CONSENT FOR REFERRING THE DISPUTES TO CONCILIATION THROUGH IEC

To,

M/s. (Stakeholder's name)

Sub: Resolution of the Disputes through conciliation by Independent Expert Committee (IEC).

Ref: Contract No/MoU/Agreement/LOI/LOA& date _____.

Sir,

With reference to above referred Contract/MoU/Agreement/LOI/LOA, you have raised certain Disputes/claims. Vide your letter dated____ you have requested BHEL to refer the Disputes/claims to IEC for Conciliation.

We are enclosing herewith Format (3) for giving consent and the terms and conditions of BHEL Conciliation Scheme, 2018 governing conciliation through IEC. You are requested to give your unconditional consent to the said terms and conditions of the Scheme by returning the same duly sealed and signed on each page. On receipt of your consent, matter will be put to the Competent Authority for consideration and decision.

Please note that BHEL has also certain claims against you (if applicable). BHEL reserves its right to agree or not to agree conciliation of the said disputes through BHEL and this letter is being issued without prejudice to BHEL's rights and contentions available under the contract and law.

Yours faithfully,

Representative of BHEL





General Conditions of Contract (GCC) of MM Tenders

BHARAT HEAVY ELECTRICALS LIMITED

Industrial Valve Plant: 433, Industrial Complex,
Goindwal Sahib, Dist. Tarn Taran,
Punjab-143422 (INDIA)

Appendix-II of Annexure-X

FORMAT FOR GIVING CONSENT BY CONTRACTOR/VENDOR/CUSTOMER/COLLABORATOR/CONSORTI UM PARTNERS FOR REFERRING THE DISPUTES TO CONCILIATION THROUGH IEC

To,

BHEL

.....

Sub: Resolution of Disputes through Conciliation by Independent Expert Committee (IEC).

Ref: Contract/MoU/Agreement/LOI/LOA No

& date ____

With reference to above referred contract, our following bills/invoices/claims submitted to BHEL are still unpaid giving rise to Disputes:

SL. no.	Claim Description	Bill submitted to BHEL (no. and date)	Amount of the bill/claim	Amount received from BHEL	Outstanding Amount

Accordingly, we request you to kindly refer the Disputes in respect of above claims to IEC for Conciliation.

We hereby agree and give our unconditional consent to the terms and conditions of BHEL Conciliation Scheme, 2018 governing conciliation through IEC. We have signed the same on each page and enclosed it for your consideration.

Yours faithfully,

(Signature with stamp)

**Authorized Representative of Contractor
Name, with designation Date**





General Conditions of Contract (GCC) of MM Tenders

BHARAT HEAVY ELECTRICALS LIMITED

Industrial Valve Plant: 433, Industrial Complex,
Goindwal Sahib, Dist. Tarn Taran,
Punjab-143422 (INDIA)

Appendix-III of Annexure-X

STATEMENT OF CLAIMS/COUNTER CLAIMS TO BE SUBMITTED TO THE IEC BY BOTH THE PARTIES

1. Chronology of the Disputes
2. Brief of the Contract/MoU/Agreement/LOI/LOA
3. Brief history of the Disputes:
4. Issues:
5. Details of Clam(s)/Counter Claim(s):

SI. No.	Description of claim(s)/Counter Claim	Amount (in INR) Or currency applicable in the contract	Relevant contract clause

6. Basis/Ground of claim(s)/counter claim(s) (along with relevant clause of contract)

Note– The Statement of Claims/Counter Claims may ideally be restricted to maximum limit of 20 pages. Relevant documents may be compiled and submitted along with the statement of Claims/Counter Claims. The statement of Claims/Counter Claims is to be submitted to all IEC members and to the other party by post as well as by email.



Tender Enquiry No. 2425-005E Dated 18.04.2024 Due date 30.04.2024

Tender Description: HSFG Fasteners [Rate Contract]

(Annexure - P)

Pre-Qualification Criteria – As per Tender Special Term S2.c							
S.N.	Required executed order value as per NIT (Net of Taxes) (INR)	Executed order value (Net of Taxes) as per bidder (INR)	Purchase order no. and date [PO date should be on or after 01.04.2021 till bid opening date]	Purchase Order issued by (Client name) M/s	Item description as per PO	Documents submitted against completion /execution proof of the afore mentioned PO (Invoice / Consignee Receipt Note / Completion Certificate) [Document date should be on or after 01.04.2021 till bid opening date]	Full address of the client and contact person (Name & Details i.e. Mail ID, Mobile No. etc)
1							
2							
3							
4							
5							
6							
7							

More lines can be added, if required.

Notes : -

1. Kindly attach all the above stated documents in the Quotation.
2. All proof of execution like Invoice / Consignee Receipt Note / Completion Certificate must include the Purchase Order reference number, otherwise that PO will not be considered for the fulfilment of this tender term.

Tender Enquiry No. 2425-005E Dated 18.04.2024 Due date 30.04.2024

Tender Description: HSFG Fasteners [Rate Contract]

(Annexure- Q)

Confirmations of Special Terms :

SPECIAL TERMS	CONFIRMATION BY BIDDER
Delivery Destination for the all the 84 items in the tender are as follows:- <i>Sr. No. 1 to 27: NTPC Talcher TPP Stage-III, 2x660 MW Angul, Odisha - 759101</i> <i>Sr.no. 28 to 46 : NTPC Lara STPP Stage-II 2 x 800 MW, Pussore, Chappora Chhattisgarh - 496440</i> <i>Sr.no. 47 to 65 : Talabira 2x800MW, Village Talabira, Distt: Sambalpur, Odisha</i> <i>Sr. no. 66 to 84 : Yamunanagar 1x800MW, Yamunanagar – Haryana</i>	Yes / No
Rust preventive coating is to be applied on all the items (as per Special Term S1. E)	Yes / No
Unloading of Material at all project sites is in the Scope of BHEL Site Office (as per Tender Special Term S5).	Yes / No
Validity of Offer: Bids shall be valid till 30 th June 2024. (as per Tender Special Term S6). Validity of Contract: 18 Months (as per Tender Special Term S7).	Yes / No
Price Variation Clause (as per Special Term S9).	Yes / No
Packing of Material (as per Tender Special Term S15).	Yes / No
Rates quoted by the bidder against this tender is excluding of Taxes and on FOR delivery Destination basis.	Yes / No
Integrity Pact as per Tender Special Term S18 Kindly ensure to fill the following details in Annexure- R, before submitting: - a) Name of the Bidder in the Page -1 of the Integrity Pact. b) Signature and stamp of the bidder in the Page-6 (last page) of Integrity Pact. c) Signature, Name and address of the Witness in the Page-6 (last page) of Integrity Pact.	Yes / No
Differential Freight (as per Tender Special Term S19).	Yes / No
Undertaking that Bidder have read and understand all Drawings/QCP and other terms and conditions and comply the same.	Yes / No

Authorized Signatory with seal

(Annexure – R)

INTEGRITY PACT

Between

Bharat Heavy Electricals Ltd. (BHEL), a company registered under the Companies Act 1956 and having its registered office at "BHEL House", Siri Fort, New Delhi - 110049 (India) hereinafter referred to as "The Principal", which expression unless repugnant to the context or meaning hereof shall include its successors or assigns of the ONE PART

and

_____, (description of the party along with address), hereinafter referred to as "The Bidder/ Contractor" which expression unless repugnant to the context or meaning hereof shall include its successors or assigns of the OTHER PART

Preamble

The Principal intends to award, under laid-down organizational procedures, contract/s for

Tender enquiry no. 2425-005E dated 18.04.2024 for the HSFG Fasteners [Rate Contract].

(hereinafter referred to as "Contract"). The Principal values full compliance with all relevant laws of the land, rules and regulations, and the principles of economic use of resources, and of fairness and transparency in its relations with its Bidder(s)/ Contractor(s).

In order to achieve these goals, the Principal will appoint panel of Independent External Monitor(s) (IEMs), who will monitor the tender process and the execution of the contract for compliance with the principles mentioned above.

Section 1- Commitments of the Principal

1.1 The Principal commits itself to take all measures necessary to prevent corruption and to observe the following principles: -

1.1.1 No employee of the Principal, personally or through family members, will in connection with the tender for, or the execution of a contract, demand, take a promise for or accept, for self or third person, any material or immaterial benefit which the person is not legally entitled to.

1.1.2 The Principal will, during the tender process treat all Bidder(s) with equity and reason. The Principal will in particular, before and during the tender process, provide to all Bidder(s) the same information and will not provide to any Bidder(s) confidential/ additional information through which the Bidder(s) could obtain an advantage in relation to the tender process or the contract execution.

1.1.3 The Principal will exclude from the process all known prejudiced persons.

1.2 If the Principal obtains information on the conduct of any of its employees which is a penal offence under the Indian Penal Code 1860 and Prevention of Corruption Act 1988 or any other statutory

penal enactment, or if there be a substantive suspicion in this regard, the Principal will inform its Vigilance Office and in addition can initiate disciplinary actions.

Section 2 - Commitments of the Bidder(s)/ Contractor(s)

2.1 The Bidder(s)/ Contractor(s) commit himself to take all measures necessary to prevent corruption. The Bidder(s)/ Contractor(s) commits himself to observe the following principles during participation in the tender process and during the contract execution.

2.1.1 The Bidder(s)/ Contractor(s) will not, directly or through any other person or firm, offer, promise or give to the Principal or to any of the Principal's employees involved in the tender process or the execution of the contract or to any third person any material, immaterial or any other benefit which he/ she is not legally entitled to, in order to obtain in exchange any advantage of any kind whatsoever during the tender process or during the execution of the contract.

2.1.2 The Bidder(s)/ Contractor(s) will not enter with other Bidder(s) into any illegal or undisclosed agreement or understanding, whether formal or informal. This applies in particular to prices, specifications, certifications, subsidiary contracts, submission or non-submission of bids or any other actions to restrict competitiveness or to introduce cartelization in the bidding process.

2.1.3 The Bidder(s)/ Contractor(s) will not commit any penal offence under the relevant Indian Penal Code (IPC) and Prevention of Corruption Act; further the Bidder(s)/ Contractor(s) will not use improperly, for purposes of competition or personal gain, or pass on to others, any information or document provided by the Principal as part of the business relationship, regarding plans, technical proposals and business details, including information contained or transmitted electronically.

2.1.4 Foreign Bidder(s)/ Contractor(s) shall disclose the name and address of agents and representatives in India and Indian Bidder(s)/ Contractor(s) to disclose their foreign principals or associates. The Bidder(s)/ Contractor(s) will, when presenting his bid, disclose any and all payments he has made, and is committed to or intends to make to agents, brokers or any other intermediaries in connection with the award of the contract.

2.2 The Bidder(s)/ Contractor(s) will not instigate third persons to commit offences outlined above or be an accessory to such offences.

2.3 The Bidder(s)/ Contractor(s) shall not approach the Courts while representing the matters to JEMs and shall await their decision in the matter.

Section 3 - Disqualification from tender process and exclusion from future contracts

If the Bidder(s)/ Contractor(s), before award or during execution has committed a transgression through a violation of Section 2 above, or acts in any other manner such as to put his reliability or credibility in question, the Principal is entitled to disqualify the Bidder(s)/ Contractor(s) from the tender process, terminate the contract, if already awarded, exclude from future business dealings and/ or take action as per the separate "Guidelines on Banning of Business dealings with Suppliers/ Contractors", framed by the Principal.

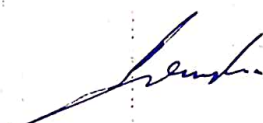

Semest

Section 4 - Compensation for Damages

- 4.1 If the Principal has disqualified the Bidder (s) from the tender process before award / order acceptance according to Section 3, the Principal is entitled to demand and recover the damages equivalent to Earnest Money Deposit/ Bid Security.
- 4.2 If the Principal is entitled to terminate the Contract according to Section 3, or terminates the Contract in application of Section 3 above, the Bidder(s)/ Contractor (s) transgression through a violation of Section 2 above shall be construed breach of contract and the Principal shall be-entitled to demand and recover from the Contractor an amount equal to 5% of the contract value or the amount equivalent to Security Deposit/ Performance Bank Guarantee, whichever is higher, as damages, in addition to and without prejudice to its right to demand and recover compensation for any other loss or damages specified elsewhere in the contract.

Section 5 - Previous Transgression

- 5.1 The Bidder declares that no previous transgressions occurred in the last 3 (three) years with any other company in any country conforming to the anti-corruption approach or with any other Public Sector Enterprise in India that could justify his exclusion from the tender process.
- 5.2 If the Bidder makes incorrect statement on this subject, he can be disqualified from the tender process or the contract, if already awarded, can be terminated for such reason or action can be taken as per the separate "Guidelines on Banning of Business dealings with Suppliers/ Contractors", framed by the Principal.

Section 6 - Equal treatment of all Bidder (s)/ Contractor (s) / Sub-contractor (s)

- 6.1 The Principal will enter into Integrity Pacts with identical conditions as this Integrity Pact with all Bidders and Contractors.
- 6.2 In case of Sub-contracting, the Principal Contractor shall take the responsibility of the adoption of Integrity Pact by the Sub-contractor(s) and ensure that all Sub-contractors also sign the Integrity Pact.
- 6.3 The Principal will disqualify from the tender process all Bidders who do not sign this Integrity Pact or violate its provisions.

Section 7 - Criminal Charges against violating Bidders/ Contractors /Subcontractors

If the Principal obtains knowledge of conduct of a Bidder, Contractor or Subcontractor, or of an employee or a representative or an associate of a Bidder, Contractor or Subcontractor which constitutes corruption, or if the Principal has substantive suspicion in this regard, the Principal will inform the Vigilance Office.

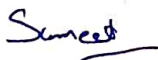

Section 8 -Independent External Monitor(s)

- 8.1 The Principal appoints competent and credible panel of Independent External Monitor (s) (IEMs) for this Integrity Pact. The task of the IEMs is to review independently and objectively, whether and to what extent the parties comply with the obligations under this Integrity Pact.
- 8.2 The IEMs are not subject to instructions by the representatives of the parties and performs his functions neutrally and independently. He reports to the CMD, BHEL.
- 8.3 The IEMs shall be provided access to all documents/ records pertaining to the Contract, for which a complaint or issue is raised before them as and when warranted. However, the documents/records/information having National Security implications and those documents which have been classified as Secret/Top Secret are not to be disclosed.
- 8.4 The Principal will provide to the IEMs sufficient information about all meetings among the parties related to the Contract provided such meetings could have an impact on the contractual relations between the Principal and the Contractor. The parties offer to the IEMs the option to participate in such meetings.
- 8.5 The advisory role of IEMs is envisaged as that of a friend, philosopher and guide. The advice of IEMs would not be legally binding and it is restricted to resolving issues raised by a Bidder regarding any aspect of the tender which allegedly restricts competition or bias towards some Bidders. At the same time, it must be understood that IEMs are not consultants to the Management. Their role is independent in nature and the advice once tendered would not be subject to review at the request of the organization.
- 8.6 For ensuring the desired transparency and objectivity in dealing with the complaints arising out of any tendering process or during execution of Contract, the matter should be examined by the full panel of IEMs jointly, who would look into the records, conduct an investigation, and submit their joint recommendations to the Management.
- 8.7 The IEMs would examine all complaints received by them and give their recommendations/ views to the CMD, BHEL at the earliest. They may also send their report directly to the CVO, in case of suspicion of serious irregularities requiring legal/ administrative action. Only in case of very serious issue having a specific, verifiable Vigilance angle, the matter should be reported directly to the Commission. IEMs will tender their advice on the complaints within 30 days.
- 8.8 The CMD, BHEL shall decide the compensation to be paid to the IEMs and its terms and conditions.
- 8.9 IEMs should examine the process integrity, they are not expected to concern themselves with fixing of responsibility of officers. Complaints alleging mala fide on the part of any officer of the Principal should be looked into by the CVO of the Principal.
- 8.10 If the IEMs have reported to the CMD, BHEL, a substantiated suspicion of an offence under relevant Indian Penal Code / Prevention of Corruption Act, and the CMD, BHEL has not, within reasonable time, taken visible action to proceed against such offence or reported it to the Vigilance Office, the IEMs may also transmit this information directly to the Central Vigilance Commissioner, Government of India.



- 8.11 After award of work, the IEMs shall look into any issue relating to execution of Contract, if specifically raised before them. As an illustrative example, if a Contractor who has been awarded the Contract, during the execution of Contract, raises issue of delayed payment etc. before the IEMs, the same shall be examined by the panel of IEMs. Issues like warranty/ guarantee etc. shall be outside the purview of IEMs.
- 8.12 However, the IEMs may suggest systemic improvements to the management of the Principal, if considered necessary, to bring about transparency, equity and fairness in the system of procurement.
- 8.13 The word 'Monitor' would include both singular and plural.

Section 9 - Pact Duration

- 9.1 This Integrity Pact shall be operative from the date this Integrity Pact is signed by both the parties till the final completion of contract for successful Bidder, and for all other Bidders 6 months after the Contract has been awarded. Any violation of the same would entail disqualification of the bidders and exclusion from future business dealings.
- 9.2 If any claim is made/ lodged during currency of this Integrity Pact, the same shall be binding and continue to be valid despite the lapse of this Pact as specified above, unless it is discharged/ determined by the CMD, BHEL.

Section 10 - Other Provisions

- 10.1 This Integrity Pact is subject to Indian Laws and exclusive jurisdiction shall be of the competent Courts as indicated in the Tender or Contract, as the case may be.
- 10.2 Changes and supplements as well as termination notices need to be made in writing.
- 10.3 If the Bidder(s)/ Contractor(s) is a partnership or a consortium or a joint venture, this Integrity Pact shall be signed by all partners of the partnership or joint venture or all consortium members.
- 10.4 Should one or several provisions of this Integrity Pact turn out to be invalid, the remainder of this Integrity Pact remains valid. In this case, the parties will strive to come to an agreement to their original intentions.
- 10.5 Only those bidders / contractors who have entered into this Integrity Pact with the Principal would be competent to participate in the bidding. In other words, entering into this Integrity Pact would be a preliminary qualification.
- 10.6 In the event of any dispute between the Principal and Bidder(s)/ Contractor(s) relating to the Contract, in case, both the parties are agreeable, they may try to settle dispute through Mediation before the panel of IEMs in a time bound manner. In case, the dispute remains unresolved even after mediation by the panel of IEMs, either party may take further action as the terms & conditions of the Contract. The fees/expenses on dispute resolution through mediation shall be shared by both the parties. Further, the mediation proceedings shall be confidential in nature and the parties shall

keep confidential all matters relating to the mediation proceedings including any settlement agreement arrived at between the parties as outcome of mediation. Any views expressed, suggestions, admissions or proposals etc. made by either party in the course of mediation shall not be relied upon or introduced as evidence in any further arbitral or judicial proceedings, whether or not such proceedings relate to the dispute that is the subject of mediation proceedings. Neither of the parties shall present IEMs as witness in any Alternative Dispute Resolution or judicial proceedings in respect of the dispute that was subject of mediation.

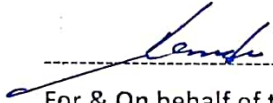

For & On behalf of the Principal

For & On behalf of the Bidder/ Contractor

Sh. Pranshu
Manager/MM
BHEL IVP Goindwal Sahib

(Office Seal)

Place: Goindwal Sahib
Date 18.04.2024

प्राणु/PRANSHU
प्रबंधक/Manager/सामग्री प्रबंधक/Material Management
भारत हेवी इलेक्ट्रिकल्स लिमिटेड
BHARAT HEAVY ELECTRICALS LIMITED
भारत सरकार का उपक्रम/A Govt. of India Undertaking
इंडस्ट्रियल वाल्व्स प्लांट/433, Industrial Valves Plant,
गोइंदवाल (तारन तारन)/Goindwal, (Tarn Taran)

(Office Seal)

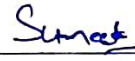
Witness: 

Witness: _____

(Name) **सुमीत बंसल/SUMEET BANSAL**
Sr. Assistant Dy. General Manager
सामग्री प्रबंधक/Material Management
भारत हेवी इलेक्ट्रिकल्स लिमिटेड
BHARAT HEAVY ELECTRICALS LIMITED
भारत सरकार का उपक्रम/A Govt. of India Undertaking
इंडस्ट्रियल वाल्व्स प्लांट/433, Industrial Valves Plant,
गोइंदवाल (तारन तारन)/Goindwal, (Tarn Taran)
Sh. Sumeet Bansal
DGM / Material Management
Bharat Heavy Electricals Ltd
433, Industrial Complex
Industrial Valves Plant
Goindwal Sahib, Tarn Taran
Punjab - 143422

(Name & Address) _____

(Annexure- S)

[Note: IF bidder is PARTICIPATING IN MORE THAN ONE PROJECT SITES in Tender Enquiry 2324-005E dt. 18.04.2024, only then this certificate is required to be submitted from the practicing chartered accountant with Valid UDIN or from statutory auditor of the company (in case of companies) or from a practicing cost accountant giving the percentage of local content]

Make in India (MII) and Local Content Declaration

To whom it may concern

In line with Government Public Procurement Order No. P-45021/2/2017-BE-II dt. 15.06.2017, as amended from time to time and as applicable on the date of submission of tender, we hereby certify that we M/s. _____ (supplier name) are (tick whichever is applicable as below)

“**Class-I local supplier**” meeting the requirement of minimum local content equal to 50% or more defined in above mentioned government notification for the goods & services

 Tick Here

(or)

“**Class-II local supplier**” meeting the requirement of minimum local content 20 % to less than 50% defined in above mentioned government notification for the goods & services

 Tick Here

(or)

Non-local supplier (if not belonging to Class-I & Class-II)

 Tick Here

against Tender Enquiry No. **2324-005E dt. 18.04.2024**

Product: **HSFG Fasteners [Rate Contract]**

Details of location at which local value addition will be made is as follows:

We also understand, false declarations will be considered as breach of Integrity and will be liable for action.

Authorized Signatory _____

UDIN _____
(for Practicing Chartered Accountants)

PART-I (TECHNO-COMMERCIAL BID)

(To be filled by bidder & submit with offer as pdf file only)

Tender Enquiry No. & Date

2425-005E Dt. 18.04.2024

Tender Description

HSFG Fasteners (Rate Contract Basis)

Bidder must note following points:

1. This workbook is protected, except for cells where comments / confirmation is to be given by bidder.
2. Bidder is advised not to unprotect / tamper the sheet / alter the terms mentioned in the sheet.
3. Any alteration to terms mentioned by BHEL will be considered as tampering and bidder's offer shall be liable for rejection.
4. **Bidders are advised to only fill the unprotected cells (shaded cells) by dropdown or writing the comments as applicable as their confirmation. Bidders are advised to submit duly filled & signed 'PDF' file as techno-commercial (Part-I) bid.** Failure on the part of bidder in not returning this duly filled-up techno-commercial bid and / or submitting incomplete replies may lead to rejection of bidder's quotation.
5. All the commercial terms and conditions shall be indicated by vendor in this format only and nowhere else in his quotation. However, in case the space for vendor's reply is not sufficient against a particular question, the vendor shall furnish same by way of separate annexure / sheet attached to this questionnaire, indicating cross-reference of respective clauses.

BIDDER'S DETAILS

Sr. No.	Elements	Remarks
1	Name of the Firm / Company	
2	Registered Address	
3	Quotation reference no. & date	
4	Contact person Details	
	Name / Designation	
	Contact Number	
	Email ID (can be more than one)	
5	Bidder Type (Indian / Foreign):	
6	Type of Ownership	Select from drop down list
7	Company's Nature of Business	Select from drop down list
8	Year of commencement of Business	
9	PAN No.	
10	GST No.	
11	Whether company is registered under MSMED Actr 2006 as Micro / Samll / Medium Enterprise category. <i>(If yes, please attach valid certificate as per latest MSME guidelines)</i>	Select from drop down list If yes, mention UDYAM registration number Here

TECHNICAL CONDITION DETAIL

Sr. No.	Elements	Response	Remarks
1	Technical : Supply of HSFG Fasteners as per tender documents (if selected 'Accepted with deviation', please mention the deviation clearly)	Select from drop down list	

COMMERCIAL CONDITIONS & DETAILS

Sr. No.	Elements	Response	Remarks (if any)
1	IGST supply (%)	Select from drop down list	
2	SGST supply (%)	Select from drop down list	
3	CGST supply (%)	Select from drop down list	
4	Validity		
	Validity of offer : upto 30 th June 2024 (Refer special terms S6)	Select from drop down list	
	Validity of Contract : 18 Months period from the date of finalization (Refer special terms S7)	Select from drop down list	
5	Delivery period: Within 3 MONTHS from placement of PO / LOI. (refer tender special term S4)	Select from drop down list	
6	Delivery Destination (refer tender special term S1)		
	For Item at Sr.no. 1 to 27, Delivery will be at Talcher 2x660MW, Angul, Odisha	Select from drop down list	
	For Item at Sr.no. 28 to 46, Delivery will be at Lara 2x800MW, Chhattisgarh	Select from drop down list	
	For Item at Sr.no. 47 to 65, Delivery will be at Talabira 2x800MW, Sambalpur, Odisha	Select from drop down list	

PART-I (TECHNO-COMMERCIAL BID)

(To be filled by bidder & submit with offer as pdf file only)

Tender Enquiry No. & Date

2425-005E Dt. 18.04.2024

Tender Description

HSFG Fasteners (Rate Contract Basis)

Bidder must note following points:

1. This workbook is protected, except for cells where comments / confirmation is to be given by bidder.
2. Bidder is advised not to unprotect / tamper the sheet / alter the terms mentioned in the sheet.
3. Any alteration to terms mentioned by BHEL will be considered as tampering and bidder's offer shall be liable for rejection.
4. Bidders are advised to only fill the unprotected cells (shaded cells) by dropdown or writing the comments as applicable as their confirmation. **Bidders are advised to submit duly filled & signed 'PDF' file as techno-commercial (Part-I) bid'**. Failure on the part of bidder in not returning this duly filled-up techno-commercial bid and / or submitting incomplete replies may lead to rejection of bidder's quotation.
5. All the commercial terms and conditions shall be indicated by vendor in this format only and nowhere else in his quotation. However, in case the space for vendor's reply is not sufficient against a particular question, the vendor shall furnish same by way of separate annexure / sheet attached to this questionnaire, indicating cross-reference of respective clauses.

		For Item at Sr.no. 66 to 84, Delivery will be at Yamunanagar 1x800MW, Haryana	Select from drop down list	
7		Unloading (refer tender special term S5)	Select from drop down list	

PART-I (TECHNO-COMMERCIAL BID)

(To be filled by bidder & submit with offer as pdf file only)

Tender Enquiry No. & Date

2425-005E Dt. 18.04.2024

Tender Description

HSFG Fasteners (Rate Contract Basis)

Bidder must note following points:

1. This workbook is protected, except for cells where comments / confirmation is to be given by bidder.
2. Bidder is advised not to unprotect / tamper the sheet / alter the terms mentioned in the sheet.
3. Any alteration to terms mentioned by BHEL will be considered as tampering and bidder's offer shall be liable for rejection.
4. **Bidders are advised to only fill the unprotected cells (shaded cells) by dropdown or writing the comments as applicable as their confirmation. Bidders are advised to submit duly filled & signed 'PDF' file as techno-commercial (Part-I) bid.** Failure on the part of bidder in not returning this duly filled-up techno-commercial bid and / or submitting incomplete replies may lead to rejection of bidder's quotation.
5. All the commercial terms and conditions shall be indicated by vendor in this format only and nowhere else in his quotation. However, in case the space for vendor's reply is not sufficient against a particular question, the vendor shall furnish same by way of separate annexure / sheet attached to this questionnaire, indicating cross-reference of respective clauses.

8	Self Declaration by Bidder : It is hereby declared that Bidder is 'manufacturer of Fasteners' (Refer special terms S2.a).	Select from drop down list				
9	Bidder should have Minimum Average Annual Financial turnover of Rs. [as mentioned in Table 2 of Special Terms S2.b] for each project, over three financial years viz. FY 2020-21, 2021-22 and 2022-23.	Talcher 2x660MW, Angul, Odisha	Select from drop down list (Not Participated)	Select from drop down list (Not Participated)	Select from drop down list (Not Participated)	
		Lara 2x800MW, Chhattisgarh	Select from drop down list (Not Participated)	Select from drop down list (Not Participated)	Select from drop down list (Not Participated)	
		Talabira 2x800MW, Sambalpur, Odisha	Select from drop down list (Not Participated)	Select from drop down list (Not Participated)	Select from drop down list (Not Participated)	
		Yamunanagar 1x800MW, Haryana	Select from drop down list (Not Participated)	Select from drop down list (Not Participated)	Select from drop down list (Not Participated)	
	Bidder has to submit one or more purchase order/s of 'similar item' from any customer with minimum cumulative value of Rs. [as mentioned in Table 3 of Special Terms S2.c] along with the proof of execution	Regarding Special Terms S2.b : If bidder is quoting for more than one project, then minimum Turnover value of bidder will be sum of the values mentioned corresponding to each project.	Select from drop down list			
Bidder shall have capacity to supply minimum of [MT as mentioned in Table 5 of Special Terms S2.d] of HSFG Fasteners per month for reach project, for the order placed by BHEL IVP Goindwal.	Regarding Special Terms S2.c : If bidder is quoting for more than one project, then minimum Cumulative Value of PO along with corresponding value of proof of execution like invoice, etc. , will be sum of the values mentioned corresponding to each project.	Select from drop down list				
	Regarding Special Terms S2.d : If bidder is quoting for more than one project, then minimum spare capacity of bidder will be sum of the values mentioned corresponding to each project.	Select from drop down list				
10	TOTAL Monthly Commitment of Supply of HSFG Fasteners for all (quoted) projects, per month to BHEL Goindwal (Refer special term S3 (d))	Please mention in MT (should not be less than sum total of Minimum Spare Capacity mentioned against the above Participated/Quoted projects)				
11	Confirmations of Special terms as per Annexure-Q (Refer special term S3.f)	Select from drop down list				
12	Packing of Material should be in Gunny bags and then in Wooden box (Refer special terms S15)	Select from drop down list				
13	Detention Charges - while unloading at site (Refer special terms S16)	Select from drop down list				

PART-I (TECHNO-COMMERCIAL BID)
(To be filled by bidder & submit with offer as pdf file only)

Tender Enquiry No. & Date

2425-005E Dt. 18.04.2024

Tender Description

HSFG Fasteners (Rate Contract Basis)

Bidder must note following points:

1. This workbook is protected, except for cells where comments / confirmation is to be given by bidder.
2. Bidder is advised not to unprotect / tamper the sheet / alter the terms mentioned in the sheet.
3. Any alteration to terms mentioned by BHEL will be considered as tampering and bidder's offer shall be liable for rejection.
4. **Bidders are advised to only fill the unprotected cells (shaded cells) by dropdown or writing the comments as applicable as their confirmation. Bidders are advised to submit duly filled & signed 'PDF' file as techno-commercial (Part-I) bid'. Failure on the part of bidder in not returning this duly filled-up techno-commercial bid and / or submitting incomplete replies may lead to rejection of bidder's quotation.**
5. All the commercial terms and conditions shall be indicated by vendor in this format only and nowhere else in his quotation. However, in case the space for vendor's reply is not sufficient against a particular question, the vendor shall furnish same by way of separate annexure / sheet attached to this questionnaire, indicating cross-reference of respective clauses.

14	Compliances (Refer special terms S14)	Bidder has to manufacture and supply the material complying all the latest applicable Notifications / Orders issued by the Bureau of Indian standards (BIS) or any Government agency.	Select from drop down list	
		The Gazette notification no. CG-DL-E-22072023-247533 dt. 21.07.2023 applicable to these fasteners may be referred. The bidder has to confirm that material to be supplied shall in compliance to latest BIS guidelines issued and amended till date of supply.	Select from drop down list	

PART-I (TECHNO-COMMERCIAL BID)

(To be filled by bidder & submit with offer as pdf file only)

Tender Enquiry No. & Date

2425-005E Dt. 18.04.2024

Tender Description

HSFG Fasteners (Rate Contract Basis)

Bidder must note following points:

1. This workbook is protected, except for cells where comments / confirmation is to be given by bidder.
2. Bidder is advised not to unprotect / tamper the sheet / alter the terms mentioned in the sheet.
3. Any alteration to terms mentioned by BHEL will be considered as tampering and bidder's offer shall be liable for rejection.
4. **Bidders are advised to only fill the unprotected cells (shaded cells) by dropdown or writing the comments as applicable as their confirmation. Bidders are advised to submit duly filled & signed 'PDF' file as techno-commercial (Part-I) bid'. Failure on the part of bidder in not returning this duly filled-up techno-commercial bid and / or submitting incomplete replies may lead to rejection of bidder's quotation.**
5. All the commercial terms and conditions shall be indicated by vendor in this format only and nowhere else in his quotation. However, in case the space for vendor's reply is not sufficient against a particular question, the vendor shall furnish same by way of separate annexure / sheet attached to this questionnaire, indicating cross-reference of respective clauses.

15	Compliance to Integrity Pact. Bidder has to attach the undertaking along with offer as per Annexure-R (Refer special term S18 and S3.g)	Select from drop down list	
16	<u>Performance Security (PS) :</u> Successful bidders are required to submit PS of Rs 2.0 lakhs after entering into rate contract with successful bidders. PS shall be valid for a period of 41 months. Successful bidder has to submit PS within 21 days from the date of placement of first purchase order under RC (Refer special term S21)	Select from drop down list	
17	Breach of contract and Termination (Refer special term S22)	Select from drop down list	
18	Conflict of Interest among Bidders / Agents (Refer clause no. 8 of General Contract conditions (GCC))	Select from drop down list	
19	LD clause: Penalty for late delivery will be applicable @ 0.5% per week or part thereof subject to a maximum of 10.0 %. (Refer Clause 12 of General Contract Conditions (GCC)).	Select from drop down list	
20	Payment term: (Refer clause no. 14 of General Contract conditions (GCC))	Select from drop down list	
21	Price Variation Clause (PVC) Applicable: (Refer special term S9)	Select from drop down list	
22	Warranty Period: Supplier shall give a warrantee for a period of 18 months from the date of receipt. In case of non-acceptance of this term bid will be rejected. (Refer clause no. 18 of GCC)	Select from drop down list	
23	Please attach valid MSE certificate latest MSME Guidelines (Refer clause no. 26 of GCC)	Select from drop down list	
24	Make in India (MII) (Refer clause no. 27 of GCC and Special Terms S3.h)	Local Content Declaration	Select from drop down list
		Details of location at which local value addition will be made is as follows:	Select from drop down list
		IF bidder is PARTICIPATING IN MORE THAN ONE PROJECT SITES - Duly Filled Annexure - S (Make in India Declaration Certificate from CA along with valid UDIN) to be attached	Select from drop down list
25	Certificate regarding Restrictions Under Rule 144(XI) of The GFR, 2017 (Refer clause no. 28 of GCC)	I have read the clause regarding restrictions on procurement from a bidder of a country which shares a land border with India; I certify that this bidder is not from such a country or, if from such a country, has been registered with the Competent Authority. I hereby certify that this bidder fulfils all requirements in this regard and is eligible to be considered.	Select from drop down list
26	Firm Price: The quoted / finalised rates shall be firm till execution of the supplies.	Select from drop down list	
27	I have thoroughly gone through the attached tender terms & conditions and understood the above techno-commercial requirements	Select from drop down list	

PART-I (TECHNO-COMMERCIAL BID)

(To be filled by bidder & submit with offer as pdf file only)

Tender Enquiry No. & Date

2425-005E Dt. 18.04.2024

Tender Description

HSFG Fasteners (Rate Contract Basis)

Bidder must note following points:

1. This workbook is protected, except for cells where comments / confirmation is to be given by bidder.
2. Bidder is advised not to unprotect / tamper the sheet / alter the terms mentioned in the sheet.
3. Any alteration to terms mentioned by BHEL will be considered as tampering and bidder's offer shall be liable for rejection.
4. **Bidders are advised to only fill the unprotected cells (shaded cells) by dropdown or writing the comments as applicable as their confirmation. Bidders are advised to submit duly filled & signed 'PDF' file as techno-commercial (Part-I) bid.** Failure on the part of bidder in not returning this duly filled-up techno-commercial bid and / or submitting incomplete replies may lead to rejection of bidder's quotation.
5. All the commercial terms and conditions shall be indicated by vendor in this format only and nowhere else in his quotation. However, in case the space for vendor's reply is not sufficient against a particular question, the vendor shall furnish same by way of separate annexure / sheet attached to this questionnaire, indicating cross-reference of respective clauses.

28	Rates quoted are net of taxes & FOR DESTINATION basis	Select from drop down list	
29	If there is any deviation in reference to any of the tender term, kindly mention it HERE only. Deviation specified elsewhere, will not be considered.	Select from drop down list	

Item detail

Item Sl. no.	Material Code	Description	Qty in No.	Quoted / not quoted	Quoted / not quoted
1	412371606000-ODA	BOLT-M16x60 -8.8-IS1364P1	15,660	Select from drop down list	TalcherNTPC Talcher 2x660MW, Angul – Odisha
2	413200001600-ODA	NUT -M16 -CL8-IS1364P3	15,660	Select from drop down list	
3	412371609000-ODA	BOLT-M16x90 -8.8-IS1364P1	10,550	Select from drop down list	
4	413200001600-ODA (same as Sr. no. 2)	NUT -M16 -CL8-IS1364P3	10,550	Select from drop down list	
5	414190001600-ODA	M16 WASHER Grade 10.9	26,210	Select from drop down list	
6	414190002000-ODA	M20 WASHER Grade 10.9	2,49,140	Select from drop down list	
7	412412013001-ODA	M20X130 EXTENDED HSFG BOLTS&NUTS GR.8.8	2,110	Select from drop down list	
8	412412016001-ODA	M20X160 EXTENDED HSFG BOLTS&NUTS GR.8.8	2,438	Select from drop down list	
9	412412006001-ODA	M20X60 EXTENDED HSFG BOLTS&NUTS GR.8.8	1,74,711	Select from drop down list	
10	412412009001-ODA	M20X90 EXTENDED HSFG BOLTS&NUTS GR.8.8	69,881	Select from drop down list	
11	414180002400-ODA	M24 WASHER Grade 8.8	5,56,568	Select from drop down list	
12	412400030000-ODA	M24x130 EXTENDEDHSFG BOLTS&NUTS Grade8.8	36,228	Select from drop down list	
13	412400040000-ODA	M24x170 EXTENDED HSFG BOLT &NUT Grade8.8	2,672	Select from drop down list	
14	412400050000-ODA	M24X200 EXTENDED HSFG BOLT &NUT GRADE8.8	632	Select from drop down list	
15	412400010000-ODA	M24x70 EXTENDED HSFG BOLTS&NUTS Grade8.8	3,96,836	Select from drop down list	
16	412400020000-ODA	M24x90 EXTENDED HSFG BOLTS&NUTS Grade8.8	1,20,200	Select from drop down list	
17	414190003000-ODA	M30 WASHER Grade 10.9	1,21,450	Select from drop down list	
18	412403013001-ODA	M30X130 EXTENDED HSFG BOLTS&NUTS GR.10.9	22,975	Select from drop down list	
19	412403017001-ODA	M30X170 EXTENDED HSFG BOLTS&NUTS GR.10.9	13,352	Select from drop down list	
20	412403020001-ODA	M30X200 EXTENDED HSFG BOLTS&NUTS GR.10.9	2,540	Select from drop down list	
21	412403009001-ODA	M30X90 EXTENDED HSFG BOLTS&NUTS GR.10.9	21,858	Select from drop down list	
22	414190003600-ODA	M36 WASHER Grade 10.9	4,27,942	Select from drop down list	
23	412413610001-ODA	M36X100 EXTENDED HSFG BOLT&NUT GR.10.9	70,144	Select from drop down list	
24	412413612001-ODA	M36X120 EXTENDED HSFG BOLT&NUT GR.10.9	49,095	Select from drop down list	
25	412413614001-ODA	M36X140 EXTENDED HSFG BOLT&NUT GR.10.9	66,793	Select from drop down list	
26	412413616001-ODA	M36X160 EXTENDED HSFG BOLT&NUT GR.10.9	18,439	Select from drop down list	
27	412413619001-ODA	M36X190 EXTENDED HSFG BOLT&NUT GR.10.9	9,500	Select from drop down list	
28	412371606000-CHH	BOLT-M16x60 -8.8-IS1364P1	40	Select from drop down list	2x800MW Lara project, Raigarh, Chattisgarh
29	413200001600-CHH	NUT -M16 -CL8-IS1364P3	40	Select from drop down list	
30	412371609000-CHH	BOLT-M16x90 -8.8-IS1364P1	7,060	Select from drop down list	
31	413200001600-CHH (same as Sr. no. 29)	NUT -M16 -CL8-IS1364P3	7,060	Select from drop down list	
32	414190001600-CHH	M16 WASHER Grade 10.9	7,460	Select from drop down list	
33	414190002000-CHH	M20 WASHER Grade 10.9	72,902	Select from drop down list	
34	412412006001-CHH	M20X60 EXTENDED HSFG BOLTS&NUTS GR.8.8	42,788	Select from drop down list	
35	412412009001-CHH	M20X90 EXTENDED HSFG BOLTS&NUTS GR.8.8	32,132	Select from drop down list	
36	414180002400-CHH	M24 WASHER Grade 8.8	6,27,892	Select from drop down list	
37	412400030000-CHH	M24x130 EXTENDEDHSFG BOLTS&NUTS Grade8.8	84,394	Select from drop down list	
38	412400040000-CHH	M24x170 EXTENDED HSFG BOLT &NUT Grade8.8	10,074	Select from drop down list	
39	412400010000-CHH	M24x70 EXTENDED HSFG BOLTS&NUTS Grade8.8	3,29,012	Select from drop down list	
40	412400020000-CHH	M24x90 EXTENDED HSFG BOLTS&NUTS Grade8.8	1,63,026	Select from drop down list	
41	414190003000-CHH	M30 WASHER Grade 10.9	1,33,998	Select from drop down list	
42	412403013001-CHH	M30X130 EXTENDED HSFG BOLTS&NUTS GR.10.9	28,144	Select from drop down list	

PART-I (TECHNO-COMMERCIAL BID)

(To be filled by bidder & submit with offer as pdf file only)

Tender Enquiry No. & Date

2425-005E Dt. 18.04.2024

Tender Description

HSFG Fasteners (Rate Contract Basis)

Bidder must note following points:

1. This workbook is protected, except for cells where comments / confirmation is to be given by bidder.
2. Bidder is advised not to unprotect / tamper the sheet / alter the terms mentioned in the sheet.
3. Any alteration to terms mentioned by BHEL will be considered as tampering and bidder's offer shall be liable for rejection.
4. **Bidders are advised to only fill the unprotected cells (shaded cells) by dropdown or writing the comments as applicable as their confirmation. Bidders are advised to submit duly filled & signed 'PDF' file as techno-commercial (Part-I) bid'. Failure on the part of bidder in not returning this duly filled-up techno-commercial bid and / or submitting incomplete replies may lead to rejection of bidder's quotation.**
5. All the commercial terms and conditions shall be indicated by vendor in this format only and nowhere else in his quotation. However, in case the space for vendor's reply is not sufficient against a particular question, the vendor shall furnish same by way of separate annexure / sheet attached to this questionnaire, indicating cross-reference of respective clauses.

43	412403017001-CHH	M30X170 EXTENDED HSFG BOLTS&NUTS GR.10.9	17,718	Select from drop down list	NTPC Talabira 3x800 MW, Village Talabira, Sambalpur, Odisha
44	412403009001-CHH	M30X90 EXTENDED HSFG BOLTS&NUTS GR.10.9	29,468	Select from drop down list	
45	414190003600-CHH	M36 WASHER Grade 10.9	200	Select from drop down list	
46	412413619001-CHH	M36X190 EXTENDED HSFG BOLT&NUT GR.10.9	180	Select from drop down list	
47	412371606000-ODS	BOLT-M16x60 -8.8-IS1364P1	40	Select from drop down list	
48	413200001600-ODS	NUT -M16 -CL8-IS1364P3	40	Select from drop down list	
49	412371609000-ODS	BOLT-M16x90 -8.8-IS1364P1	7,060	Select from drop down list	
50	413200001600-ODS (same as Sr. no. 48)	NUT -M16 -CL8-IS1364P3	7,060	Select from drop down list	
51	414190001600-ODS	M16 WASHER Grade 10.9	7,460	Select from drop down list	
52	414190002000-ODS	M20 WASHER Grade 10.9	72,902	Select from drop down list	
53	412412006001-ODS	M20X60 EXTENDED HSFG BOLTS&NUTS GR.8.8	42,788	Select from drop down list	
54	412412009001-ODS	M20X90 EXTENDED HSFG BOLTS&NUTS GR.8.8	32,132	Select from drop down list	
55	414180002400-ODS	M24 WASHER Grade 8.8	6,27,892	Select from drop down list	
56	412400030000-ODS	M24x130 EXTENDEDHSFG BOLTS&NUTS Grade8.8	84,394	Select from drop down list	
57	412400040000-ODS	M24x170 EXTENDED HSFG BOLT &NUT Grade8.8	10,074	Select from drop down list	
58	412400010000-ODS	M24x70 EXTENDED HSFG BOLTS&NUTS Grade8.8	3,29,012	Select from drop down list	
59	412400020000-ODS	M24x90 EXTENDED HSFG BOLTS&NUTS Grade8.8	1,63,026	Select from drop down list	
60	414190003000-ODS	M30 WASHER Grade 10.9	1,33,998	Select from drop down list	
61	412403013001-ODS	M30X130 EXTENDED HSFG BOLTS&NUTS GR.10.9	28,144	Select from drop down list	
62	412403017001-ODS	M30X170 EXTENDED HSFG BOLTS&NUTS GR.10.9	17,718	Select from drop down list	
63	412403009001-ODS	M30X90 EXTENDED HSFG BOLTS&NUTS GR.10.9	29,468	Select from drop down list	
64	414190003600-ODS	M36 WASHER Grade 10.9	200	Select from drop down list	
65	412413619001-ODS	M36X190 EXTENDED HSFG BOLT&NUT GR.10.9	180	Select from drop down list	
66	412371606000-HRY	BOLT-M16x60 -8.8-IS1364P1	20	Select from drop down list	
67	413200001600-HRY	NUT -M16 -CL8-IS1364P3	20	Select from drop down list	
68	412371609000-HRY	BOLT-M16x90 -8.8-IS1364P1	3,530	Select from drop down list	
69	413200001600-HRY (same as Sr. no. 67)	NUT -M16 -CL8-IS1364P3	3,530	Select from drop down list	
70	414190001600-HRY	M16 WASHER Grade 10.9	3,730	Select from drop down list	
71	414190002000-HRY	M20 WASHER Grade 10.9	36,451	Select from drop down list	
72	412412006001-HRY	M20X60 EXTENDED HSFG BOLTS&NUTS GR.8.8	21,394	Select from drop down list	
73	412412009001-HRY	M20X90 EXTENDED HSFG BOLTS&NUTS GR.8.8	16,066	Select from drop down list	
74	414180002400-HRY	M24 WASHER Grade 8.8	3,13,946	Select from drop down list	
75	412400030000-HRY	M24x130 EXTENDEDHSFG BOLTS&NUTS Grade8.8	42,197	Select from drop down list	
76	412400040000-HRY	M24x170 EXTENDED HSFG BOLT &NUT Grade8.8	5,037	Select from drop down list	
77	412400010000-HRY	M24x70 EXTENDED HSFG BOLTS&NUTS Grade8.8	1,64,506	Select from drop down list	
78	412400020000-HRY	M24x90 EXTENDED HSFG BOLTS&NUTS Grade8.8	81,513	Select from drop down list	
79	414190003000-HRY	M30 WASHER Grade 10.9	66,999	Select from drop down list	
80	412403013001-HRY	M30X130 EXTENDED HSFG BOLTS&NUTS GR.10.9	14,072	Select from drop down list	
81	412403017001-HRY	M30X170 EXTENDED HSFG BOLTS&NUTS GR.10.9	8,859	Select from drop down list	
82	412403009001-HRY	M30X90 EXTENDED HSFG BOLTS&NUTS GR.10.9	14,734	Select from drop down list	
83	414190003600-HRY	M36 WASHER Grade 10.9	100	Select from drop down list	
84	412413619001-HRY	M36X190 EXTENDED HSFG BOLT&NUT GR.10.9	90	Select from drop down list	

PART-I (TECHNO-COMMERCIAL BID)
(To be filled by bidder & submit with offer as pdf file only)

Tender Enquiry No. & Date

2425-005E Dt. 18.04.2024

Tender Description

HSFG Fasteners (Rate Contract Basis)

Bidder must note following points:

1. This workbook is protected, except for cells where comments / confirmation is to be given by bidder.
2. Bidder is advised not to unprotect / tamper the sheet / alter the terms mentioned in the sheet.
3. Any alteration to terms mentioned by BHEL will be considered as tampering and bidder's offer shall be liable for rejection.
4. **Bidders are advised to only fill the unprotected cells (shaded cells) by dropdown or writing the comments as applicable as their confirmation. Bidders are advised to submit duly filled & signed 'PDF' file as techno-commercial (Part-I) bid'. Failure on the part of bidder in not returning this duly filled-up techno-commercial bid and / or submitting incomplete replies may lead to rejection of bidder's quotation.**
5. All the commercial terms and conditions shall be indicated by vendor in this format only and nowhere else in his quotation. However, in case the space for vendor's reply is not sufficient against a particular question, the vendor shall furnish same by way of separate annexure / sheet attached to this questionnaire, indicating cross-reference of respective clauses.

We further, confirm that we have quoted the rates in the tender considering Inter-alia the

1. Tender Document(s)
2. Additional Document(s) (if any)
3. BOQ Document (Price Bid Format-Part-II)
4. Corrigendum (if any)
5. Pre Bid Meeting Minutes (if any)

We hereby certify that we have fully read and thoroughly understood the tender requirements and accept all terms and conditions of the tender including all corrigendum/addendum issued (if any). Our offer is in confirmation to all the terms and conditions of the tender including all corrigendum/addendum (if any) and minutes of the pre-bid meeting (if any). In the event our offer is found acceptable and Order is placed /Contract is awarded to us, the complete tender document shall be considered for constitution of Order / Contract Agreement.

Validate

Print

Help

Item Wise BoQ

Tender Inviting Authority: BHEL IVP Goindwal Sahib

Name of Work: HSWG Fasteners [Rate Contract]

Contract No: 2425-005E dated 18.04.2024

Name of the
Bidder/ Bidding
Firm /
Company :**PRICE SCHEDULE**

(This BOQ template must not be modified/replaced by the bidder and the same should be uploaded after filling the relevant columns, else the bidder is liable to be rejected for this tender. Bidders are allowed to enter the Bidder Name and Values only)

NUMBER #	TEXT #	TEXT #	NUMBER #	TEXT #	NUMBER #	NUMBER #	TEXT #
Sl. No.	Item Description Sr. no. 1 to 27: TalcherNTPC Talcher 2x660MW, Angul – Odisha Sr.no. 28 to 46 : 2x800MW Lara project, Raigarh, Chattisgarh Sr.no. 47 to 65 : NTPC Talabira 3x800 MW, Sambalpur, Odisha Sr. No. 66 to 84 : Yamunanagar 1x800MW, Yamunanagar- Haryana	Item Code / Make	Quantity	Units	BASIC RATE In Figures To be entered by the Bidder in Rs. Per piece	TOTAL AMOUNT excluding taxes in Rs. P	TOTAL AMOUNT In Words
1	2	3	4	5	7	11	13
1	BOLT-M16x60 -8.8-IS1364P1	412371606000-ODA	15,660	Number		0.00	INR Zero Only
2	NUT -M16 -CL8-IS1364P3	413200001600-ODA	15,660	Number		0.00	INR Zero Only
3	BOLT-M16x90 -8.8-IS1364P1	412371609000-ODA	10,550	Number		0.00	INR Zero Only
4	NUT -M16 -CL8-IS1364P3	413200001600-ODA (same as Sr. no. 2)	10,550	Number		0.00	INR Zero Only
5	M16 WASHER Grade 10.9	414190001600-ODA	26,210	Number		0.00	INR Zero Only
6	M20 WASHER Grade 10.9	414190002000-ODA	2,49,140	Number		0.00	INR Zero Only
7	M20X130 EXTENDED HSWG BOLTS&NUTS GR.8.8	412412013001-ODA	2,110	Number		0.00	INR Zero Only
8	M20X160 EXTENDED HSWG BOLTS&NUTS GR.8.8	412412016001-ODA	2,438	Number		0.00	INR Zero Only
9	M20X60 EXTENDED HSWG BOLTS&NUTS GR.8.8	412412006001-ODA	1,74,711	Number		0.00	INR Zero Only
10	M20X90 EXTENDED HSWG BOLTS&NUTS GR.8.8	412412009001-ODA	69,881	Number		0.00	INR Zero Only

Sl. No.	Item Description Sr. no. 1 to 27: TalcherNTPC Talcher 2x660MW, Angul – Odisha Sr.no. 28 to 46 : 2x800MW Lara project, Raigarh, Chattisgarh Sr.no. 47 to 65 : NTPC Talabira 3x800 MW, Sambalpur, Odisha Sr. No. 66 to 84 : Yamunanagar 1x800MW, Yamunanagar- Haryana	Item Code / Make	Quantity	Units	BASIC RATE In Figures To be entered by the Bidder in Rs. Per piece	TOTAL AMOUNT excluding taxes in Rs. P	TOTAL AMOUNT In Words
11	M24 WASHER Grade 8.8	414180002400-ODA	5,56,568	Number		0.00	INR Zero Only
12	M24x130 EXTENDEDHSFG BOLTS&NUTS Grade8.8	412400030000-ODA	36,228	Number		0.00	INR Zero Only
13	M24x170 EXTENDED HSFG BOLT &NUT Grade8.8	412400040000-ODA	2,672	Number		0.00	INR Zero Only
14	M24X200 EXTENDED HSFG BOLT &NUT GRADE8.8	412400050000-ODA	632	Number		0.00	INR Zero Only
15	M24x70 EXTENDED HSFG BOLTS&NUTS Grade8.8	412400010000-ODA	3,96,836	Number		0.00	INR Zero Only
16	M24x90 EXTENDED HSFG BOLTS&NUTS Grade8.8	412400020000-ODA	1,20,200	Number		0.00	INR Zero Only
17	M30 WASHER Grade 10.9	414190003000-ODA	1,21,450	Number		0.00	INR Zero Only
18	M30X130 EXTENDED HSFG BOLTS&NUTS GR.10.9	412403013001-ODA	22,975	Number		0.00	INR Zero Only
19	M30X170 EXTENDED HSFG BOLTS&NUTS GR.10.9	412403017001-ODA	13,352	Number		0.00	INR Zero Only
20	M30X200 EXTENDED HSFG BOLTS&NUTS GR.10.9	412403020001-ODA	2,540	Number		0.00	INR Zero Only
21	M30X90 EXTENDED HSFG BOLTS&NUTS GR.10.9	412403009001-ODA	21,858	Number		0.00	INR Zero Only
22	M36 WASHER Grade 10.9	414190003600-ODA	4,27,942	Number		0.00	INR Zero Only
23	M36X100 EXTENDED HSFG BOLT&NUT GR.10.9	412413610001-ODA	70,144	Number		0.00	INR Zero Only
24	M36X120 EXTENDED HSFG BOLT&NUT GR.10.9	412413612001-ODA	49,095	Number		0.00	INR Zero Only
25	M36X140 EXTENDED HSFG BOLT&NUT GR.10.9	412413614001-ODA	66,793	Number		0.00	INR Zero Only
26	M36X160 EXTENDED HSFG BOLT&NUT GR.10.9	412413616001-ODA	18,439	Number		0.00	INR Zero Only

Sl. No.	Item Description Sr. no. 1 to 27: TalcherNTPC Talcher 2x660MW, Angul – Odisha Sr.no. 28 to 46 : 2x800MW Lara project, Raigarh, Chattisgarh Sr.no. 47 to 65 : NTPC Talabira 3x800 MW, Sambalpur, Odisha Sr. No. 66 to 84 : Yamunanagar 1x800MW, Yamunanagar- Haryana	Item Code / Make	Quantity	Units	BASIC RATE In Figures To be entered by the Bidder in Rs. Per piece	TOTAL AMOUNT excluding taxes in Rs. P	TOTAL AMOUNT In Words
27	M36X190 EXTENDED HSFGBOLT&NUT GR.10.9	412413619001-ODA	9,500	Number		0.00	INR Zero Only
28	BOLT-M16x60 -8.8-IS1364P1	412371606000-CHH	40	Number		0.00	INR Zero Only
29	NUT -M16 -CL8-IS1364P3	413200001600-CHH	40	Number		0.00	INR Zero Only
30	BOLT-M16x90 -8.8-IS1364P1	412371609000-CHH	7,060	Number		0.00	INR Zero Only
31	NUT -M16 -CL8-IS1364P3	413200001600-CHH (same as Sr. no. 29)	7,060	Number		0.00	INR Zero Only
32	M16 WASHER Grade 10.9	414190001600-CHH	7,460	Number		0.00	INR Zero Only
33	M20 WASHER Grade 10.9	414190002000-CHH	72,902	Number		0.00	INR Zero Only
34	M20X60 EXTENDED HSFGBOLTS&NUTS GR.8.8	412412006001-CHH	42,788	Number		0.00	INR Zero Only
35	M20X90 EXTENDED HSFGBOLTS&NUTS GR.8.8	412412009001-CHH	32,132	Number		0.00	INR Zero Only
36	M24 WASHER Grade 8.8	414180002400-CHH	6,27,892	Number		0.00	INR Zero Only
37	M24x130 EXTENDEDHSFGBOLTS&NUTS Grade8.8	412400030000-CHH	84,394	Number		0.00	INR Zero Only
38	M24x170 EXTENDED HSFGBOLT &NUT Grade8.8	412400040000-CHH	10,074	Number		0.00	INR Zero Only
39	M24x70 EXTENDED HSFGBOLTS&NUTS Grade8.8	412400010000-CHH	3,29,012	Number		0.00	INR Zero Only
40	M24x90 EXTENDED HSFGBOLTS&NUTS Grade8.8	412400020000-CHH	1,63,026	Number		0.00	INR Zero Only
41	M30 WASHER Grade 10.9	414190003000-CHH	1,33,998	Number		0.00	INR Zero Only
42	M30X130 EXTENDED HSFGBOLTS&NUTS GR.10.9	412403013001-CHH	28,144	Number		0.00	INR Zero Only

Sl. No.	Item Description Sr. no. 1 to 27: TalcherNTPC Talcher 2x660MW, Angul – Odisha Sr.no. 28 to 46 : 2x800MW Lara project, Raigarh, Chattisgarh Sr.no. 47 to 65 : NTPC Talabira 3x800 MW, Sambalpur, Odisha Sr. No. 66 to 84 : Yamunanagar 1x800MW, Yamunanagar- Haryana	Item Code / Make	Quantity	Units	BASIC RATE In Figures To be entered by the Bidder in Rs. Per piece	TOTAL AMOUNT excluding taxes in Rs. P	TOTAL AMOUNT In Words
43	M30X170 EXTENDED HSFG BOLTS&NUTS GR.10.9	412403017001-CHH	17,718	Number		0.00	INR Zero Only
44	M30X90 EXTENDED HSFG BOLTS&NUTS GR.10.9	412403009001-CHH	29,468	Number		0.00	INR Zero Only
45	M36 WASHER Grade 10.9	414190003600-CHH	200	Number		0.00	INR Zero Only
46	M36X190 EXTENDED HSFG BOLT&NUT GR.10.9	412413619001-CHH	180	Number		0.00	INR Zero Only
47	BOLT-M16x60 -8.8-IS1364P1	412371606000-ODS	40	Number		0.00	INR Zero Only
48	NUT -M16 -CL8-IS1364P3	413200001600-ODS	40	Number		0.00	INR Zero Only
49	BOLT-M16x90 -8.8-IS1364P1	412371609000-ODS	7,060	Number		0.00	INR Zero Only
50	NUT -M16 -CL8-IS1364P3	413200001600-ODS (same as Sr. no. 48)	7,060	Number		0.00	INR Zero Only
51	M16 WASHER Grade 10.9	414190001600-ODS	7,460	Number		0.00	INR Zero Only
52	M20 WASHER Grade 10.9	414190002000-ODS	72,902	Number		0.00	INR Zero Only
53	M20X60 EXTENDED HSFG BOLTS&NUTS GR.8.8	412412006001-ODS	42,788	Number		0.00	INR Zero Only
54	M20X90 EXTENDED HSFG BOLTS&NUTS GR.8.8	412412009001-ODS	32,132	Number		0.00	INR Zero Only
55	M24 WASHER Grade 8.8	414180002400-ODS	6,27,892	Number		0.00	INR Zero Only
56	M24x130 EXTENDEDHSFG BOLTS&NUTS Grade8.8	412400030000-ODS	84,394	Number		0.00	INR Zero Only
57	M24x170 EXTENDED HSFG BOLT &NUT Grade8.8	412400040000-ODS	10,074	Number		0.00	INR Zero Only
58	M24x70 EXTENDED HSFG BOLTS&NUTS Grade8.8	412400010000-ODS	3,29,012	Number		0.00	INR Zero Only

Sl. No.	Item Description Sr. no. 1 to 27: TalcherNTPC Talcher 2x660MW, Angul – Odisha Sr.no. 28 to 46 : 2x800MW Lara project, Raigarh, Chattisgarh Sr.no. 47 to 65 : NTPC Talabira 3x800 MW, Sambalpur, Odisha Sr. No. 66 to 84 : Yamunanagar 1x800MW, Yamunanagar- Haryana	Item Code / Make	Quantity	Units	BASIC RATE In Figures To be entered by the Bidder in Rs. Per piece	TOTAL AMOUNT excluding taxes in Rs. P	TOTAL AMOUNT In Words
59	M24x90 EXTENDED HSEFG BOLTS&NUTS Grade8.8	412400020000-ODS	1,63,026	Number		0.00	INR Zero Only
60	M30 WASHER Grade 10.9	414190003000-ODS	1,33,998	Number		0.00	INR Zero Only
61	M30X130 EXTENDED HSEFG BOLTS&NUTS GR.10.9	412403013001-ODS	28,144	Number		0.00	INR Zero Only
62	M30X170 EXTENDED HSEFG BOLTS&NUTS GR.10.9	412403017001-ODS	17,718	Number		0.00	INR Zero Only
63	M30X90 EXTENDED HSEFG BOLTS&NUTS GR.10.9	412403009001-ODS	29,468	Number		0.00	INR Zero Only
64	M36 WASHER Grade 10.9	414190003600-ODS	200	Number		0.00	INR Zero Only
65	M36X190 EXTENDED HSEFG BOLT&NUT GR.10.9	412413619001-ODS	180	Number		0.00	INR Zero Only
66	BOLT-M16x60 -8.8-IS1364P1	412371606000-HRY	20	Number		0.00	INR Zero Only
67	NUT -M16 -CL8-IS1364P3	413200001600-HRY	20	Number		0.00	INR Zero Only
68	BOLT-M16x90 -8.8-IS1364P1	412371609000-HRY	3,530	Number		0.00	INR Zero Only
69	NUT -M16 -CL8-IS1364P3	413200001600-HRY (same as Sr. no. 67)	3,530	Number		0.00	INR Zero Only
70	M16 WASHER Grade 10.9	414190001600-HRY	3,730	Number		0.00	INR Zero Only
71	M20 WASHER Grade 10.9	414190002000-HRY	36,451	Number		0.00	INR Zero Only
72	M20X60 EXTENDED HSEFG BOLTS&NUTS GR.8.8	412412006001-HRY	21,394	Number		0.00	INR Zero Only
73	M20X90 EXTENDED HSEFG BOLTS&NUTS GR.8.8	412412009001-HRY	16,066	Number		0.00	INR Zero Only
74	M24 WASHER Grade 8.8	414180002400-HRY	3,13,946	Number		0.00	INR Zero Only

Sl. No.	Item Description Sr. no. 1 to 27: TalcherNTPC Talcher 2x660MW, Angul – Odisha Sr.no. 28 to 46 : 2x800MW Lara project, Raigarh, Chattisgarh Sr.no. 47 to 65 : NTPC Talabira 3x800 MW, Sambalpur, Odisha Sr. No. 66 to 84 : Yamunanagar 1x800MW, Yamunanagar- Haryana	Item Code / Make	Quantity	Units	BASIC RATE In Figures To be entered by the Bidder in Rs. Per piece	TOTAL AMOUNT excluding taxes in Rs. P	TOTAL AMOUNT In Words
75	M24x130 EXTENDEDHSFG BOLTS&NUTS Grade8.8	412400030000-HRY	42,197	Number		0.00	INR Zero Only
76	M24x170 EXTENDED HSFG BOLT &NUT Grade8.8	412400040000-HRY	5,037	Number		0.00	INR Zero Only
77	M24x70 EXTENDED HSFG BOLTS&NUTS Grade8.8	412400010000-HRY	1,64,506	Number		0.00	INR Zero Only
78	M24x90 EXTENDED HSFG BOLTS&NUTS Grade8.8	412400020000-HRY	81,513	Number		0.00	INR Zero Only
79	M30 WASHER Grade 10.9	414190003000-HRY	66,999	Number		0.00	INR Zero Only
80	M30X130 EXTENDED HSFG BOLTS&NUTS GR.10.9	412403013001-HRY	14,072	Number		0.00	INR Zero Only
81	M30X170 EXTENDED HSFG BOLTS&NUTS GR.10.9	412403017001-HRY	8,859	Number		0.00	INR Zero Only
82	M30X90 EXTENDED HSFG BOLTS&NUTS GR.10.9	412403009001-HRY	14,734	Number		0.00	INR Zero Only
83	M36 WASHER Grade 10.9	414190003600-HRY	100	Number		0.00	INR Zero Only
84	M36X190 EXTENDED HSFG BOLT&NUT GR.10.9	412413619001-HRY	90	Number		0.00	INR Zero Only



PLANT STANDARD

HPBP TIRUCHIRAPPALLI

BPS 41237

Rev. No. 01

PAGE 1 of 4

Based on IS: 1364 (Part 1) - 2018

HEXAGONAL HEAD BOLTS, PRODUCT GRADE A (Property class 8.8)

1.0 SCOPE

1.1 Covers the requirements of Hexagonal Head Bolts in the size range M6 to M16.

2.0 SPECIFICATION AND REFERENCE STANDARDS

Dimensions and Preferred sizes		Table 1 of this standard
Preferred length-size combination		Table 2 of this standard
Tolerance	Product grade	A
	Indian standard	IS: 1367 (part 2)
Thread	Pitch	Coarse
	Tolerance	6g
	Indian standard	IS: 4218 Part 3, IS: 14962 Part 2 & 3
Material		Steel
Mechanical Properties	Property class	8.8
	Indian standard	IS: 1367 Part 3
Sampling and acceptability	Indian standard	IS: 1367 Part 17
General requirements		Bolts shall comply with IS: 1364 Part 1 in respect of requirements not covered in this standard

Revisions: Brought up to date

Approved
STANDARDS SECTION
HPBP, TIRUCHIRAPPALLI

Rev. No. 01	Amd. No.	Reaffirmed	Prepared	Issued	Dt of 1 st Issue
Dt. 06.04.2022	Dt.	Year:	STANDARDS	STANDARDS	Dec 1986



PLANT STANDARD

HPBP TIRUCHIRAPPALLI

BPS 41237

Rev. No. 01

PAGE 2 of 4

2.1 Referred standards (only the relevant parts of the current versions are applicable)

IS: 1364 Part 1 Specifications for hexagon head bolts, screws & nuts of product grade A&B - Part 1 – Hexagonal bolts.

IS: 1367 Technical supply conditions for threaded steel fasteners.

IS: 4218 ISO metric screw threads.

IS: 14962 ISO General Purpose Metric Screw Threads - Tolerances

3.0 DESIGNATION

A grade A Hexagon Head Bolt to this standard of thread size M16 and nominal length 60 mm shall be designated as:

3.1 On Drawings:

1) Material specification column: IS: 1364

2) Description column : BOLT HEX GR A 8.8 M16x60

3) Drawing number column : 4123716060

4) Material code column : 4123716060

3.2 Ordering Description

For placing indents, issuing enquiries and on purchase order, the ordering description given below shall be followed.

Hexagon Bolt M16x60 IS: 1364 (part-1)-8.8

TABLE 1 DIMENSIONS FOR HEXAGONAL HEAD BOLTS

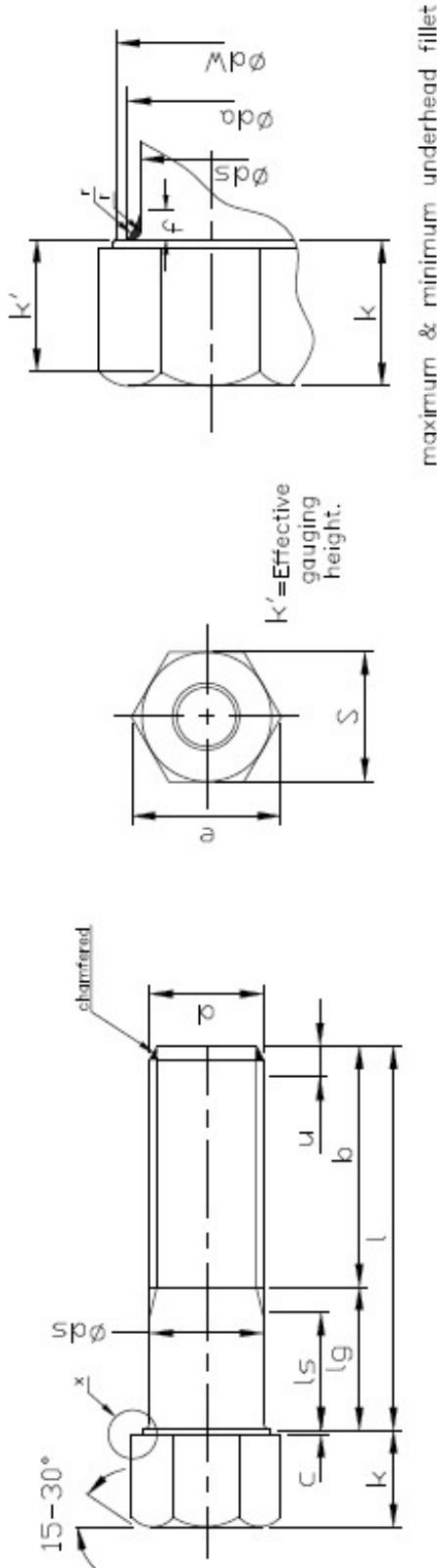

u according to CE of IS:1368 — ' Dimensions of ends of bolts and screws

lg Max=l Nom=b ; ls Min= l Max - 5xpitch

(ALL DIMENSIONS ARE IN MILLIMETERS)

Thread size d	b		C		da		ds		dw		e		f		k				r		s	
	1	2	3	Min.	Max.	Max.	Min.	Max.	Min.	Max.	Min.	Max.	Min.	Max.	Min.	Max.	Min.	Max.	Min.	Max.	Min.	Max.
M6	18	-	-	0.15	0.5	6.8	6	5.82	8.9	8.7	11.05	10.89	1.4	3.85	4.15	3.76	4.24	2.63	0.25	10	9.78	9.64
M8	22	28	-	0.15	0.6	9.2	8	7.78	11.6	11.4	14.38	14.20	2	5.15	5.45	5.06	5.54	3.54	0.4	13	12.73	12.57
M10	26	32	-	0.15	0.6	11.2	10	9.78	14.6	14.4	17.77	17.59	2	6.22	6.58	6.11	6.69	4.28	0.4	16	15.73	15.57
M12	30	36	-	0.15	0.6	13.7	12	11.73	16.6	16.4	20.03	19.85	3	7.32	7.68	7.21	7.79	5.05	0.6	18	17.73	17.57
M16	38	44	57	0.2	0.8	17.7	16	15.73	22.5	22	26.75	26.17	3	9.82	10.18	9.71	10.29	6.8	0.6	24	23.67	23.16

1) For Nom length l ≤ 125mm; + for 1 < 10d or 150mm;

2) For Nom length l > 125 and ≤ 200mm; ++ for 1 < 10d or 150mm;

3) For Nom length l > 200mm



PLANT STANDARD

HPBP TIRUCHIRAPPALLI

BPS 41237

Rev. No. 01

PAGE 4 of 4

TABLE 2- PREFERRED LENGTH-SIZE COMBINATION FOR
HEXAGON HEAD BOLTS
(ALL DIMENSIONS ARE IN MILLIMETERS)

Nom	Length 'l'				Thread size d				
	For $1 \leq 10 d$ or 150		For $1 > 10 d$ or 150		M6	M8	M10	M12	M16
	Min	Max	Min	Max					
20	19.58	20.42							
25	24.58	25.42							
30	29.58	30.42							
35	34.5	35.5	33.75	36.25					
40	39.5	40.5	38.75	41.25					
45	44.5	45.5	43.75	46.25	11.8				
50	49.5	50.5	48.75	51.25				58.7	
55	54.4	55.6	53.5	56.5				63.2	
60	59.4	60.6	58.5	61.5		28.2		67.6	123
65	64.4	65.6	63.5	66.5					
70	69.4	70.6	68.5	71.5			53.6		139
75	74.4	75.6	73.5	76.5		35.6			
80	79.4	80.6	78.5	81.5					155
90	89.3	90.7	88.25	91.75					171
100	99.3	100.7	98.25	101.75					
110	109.3	110.7	108.25	111.75					
120	119.3	120.7	118.25	121.75					
130	129.2	130.8	128	132					
140	139.2	140.8	138	142					
150	149.2	150.8	148	152					
160	159.2	160.8	158	162					
180	179.2	180.8	178	182					
200	199.08	200.92	197.7	202.3		WEIGHTS			
220	219.08	220.92	217.7	222.3					
240	239.08	240.92	237.7	242.3					
260	258.95	261.05	257.4	262.6					
280	278.95	281.05	277.4	282.6					
300	298.95	301.05	297.4	302.6					

NOTE:

1. Preferred lengths are in between the stepped bold lines
2. Weights are given in kg per 1000 numbers only



PLANT STANDARD

HPBP TIRUCHIRAPALLI

BPS:41320

PAGE 1 of 3

Based on IS: 1364 (part 3)

HEXAGON NUTS, PRODUCT GRADE A (Property Class 8)

1.0 SCOPE:

Covers the requirement of Hexagon Nuts in the size range M3 to M16.

2.0 SPECIFICATION AND REFERENCE STANDARDS

Dimensions and preferred sizes	Table 1 of this standard	
Tolerance	Product grade	A
	Indian Standard	IS: 1367(part 2)
Thread	Pitch	Coarse
	Tolerance	6H
	Indian Standard	IS: 4218(part 3, 5 & 6)
Material	Steel	
Mechanical properties	Property class	8
	Indian Standard	IS: 1367 (Part 6)
Sampling and Acceptability	Indian Standard	IS: 2614
General requirements	Nuts shall comply with IS: 1364 in respect of requirements not covered in this standard	

2.1 Referred Standards (only the relevant parts of current versions are applicable).

IS: 1364 Specification for Hexagon Head Bolts, Screws & Nuts.
(Part 3) of product grade A & B, Part 3 Hexagonal Nuts.

IS: 1367 Technical supply conditions for threaded steel fasteners.

IS: 2614 Method of sampling fasteners.

IS: 4218 ISO metric screw threads.

Revisions

Approved

STANDARDS SECTION

ENGINEERING AND DEVELOPMENT CENTER

HPBP TIRUCHIRAPALLI

Rev. No.

Amd. No.

Reaffirmed

PREPARED

Issued

Dt of 1st Issue

Dt.

Dt.

Year

HPBP TIRUCHY

STANDARD /ENGG



PLANT STANDARD

HPBP TIRUCHIRAPALLI

BPS: 41320

PAGE 2 of 3

3.0 DESIGNATION

A Grade-A Hexagonal Nut to this standard of thread size M6 shall be designated as:

3.1 On Drawings

- 1) Material Specification column : IS: 1364
- 2) Description Column : NUT HEX GR A 8-M6
- 3) Drawing Number column : 4132006000
- 4) Material code Column : 4132000006

3.2 Ordering Description

For placing indents, issuing enquiries and on Purchase order, the Ordering Description given below shall be followed:

Hex Nut M6 IS: 1364 (part-3) -8

4.0 ADDITIONAL INFORMATION

- 4.1 For nuts of thread size M20 to M48x3, product grade B, refer BPS: 41301.
- 4.2 For Cadmium plated nuts, refer BPS: 41360

COPYRIGHT AND CONFIDENTIAL

The information on this document is the property of BHARAT HEAVY ELECTRICAL LIMITED. It must not be used directly or indirectly in any way detrimental to the interest of the company.



PLANT STANDARD

HPBP TIRUCHIRAPALLI

BPS: 41320

PAGE 3 of 3

TABLE 1 DIMENSIONS FOR HEXAGONAL NUTS

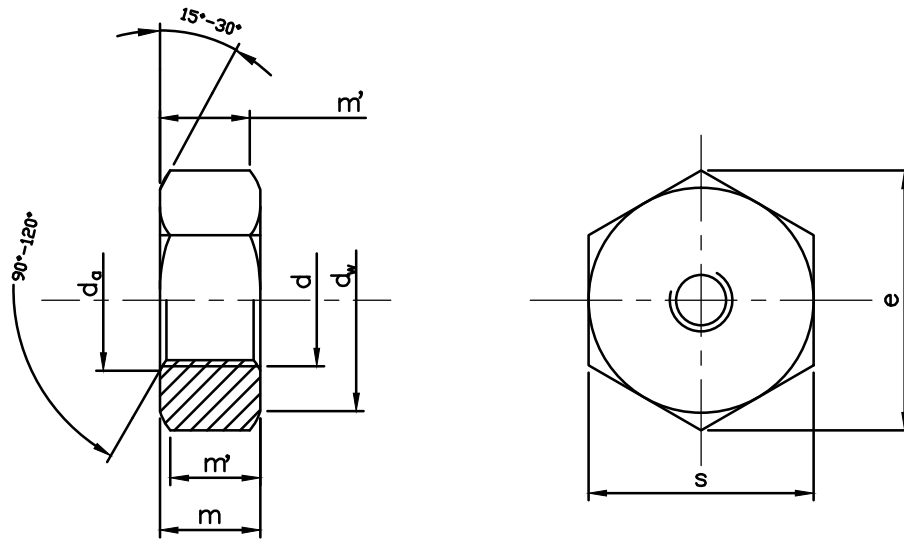

m' = Effective gauging height

(All dimension are in millimeters)

Thread Size d	d_a		d_w Min	e Min	m		m' Min	s		Weight
	Min	Max			Max	Min		Max	Min	
M3	3	3.45	4.6	6.01	2.4	2.15	1.72	5.5	5.32	0.4
M4	4	4.6	5.9	7.66	3.2	2.9	2.32	7	6.78	0.9
M5	5	5.75	6.9	8.79	4.7	4.4	3.52	8	7.78	
M6	6	6.75	8.9	11.05	5.2	4.9	3.92	10	9.78	2.5
M8	8	8.75	11.6	14.38	6.8	6.44	5.15	13	12.73	6.0
M10	10	10.8	14.6	17.77	8.4	8.04	6.43	16	15.73	11.6
M12	12	13.0	16.6	20.03	10.8	10.37	8.30	18	17.73	17.9
M16	16	17.3	22.5	26.75	14.8	14.1	11.28	24	23.67	33.5

NOTE:

1. Weights are given in kg per 1000 numbers only.
2. For stocked sizes refer BPS components booklet.

COPYRIGHT AND CONFIDENTIAL

The information on this document is the property of BHARAT HEAVY ELECTRICAL LIMITED. It must not be used directly or indirectly in any way detrimental to the interest of the company.

DRAWING NO:
3-35-700-09998

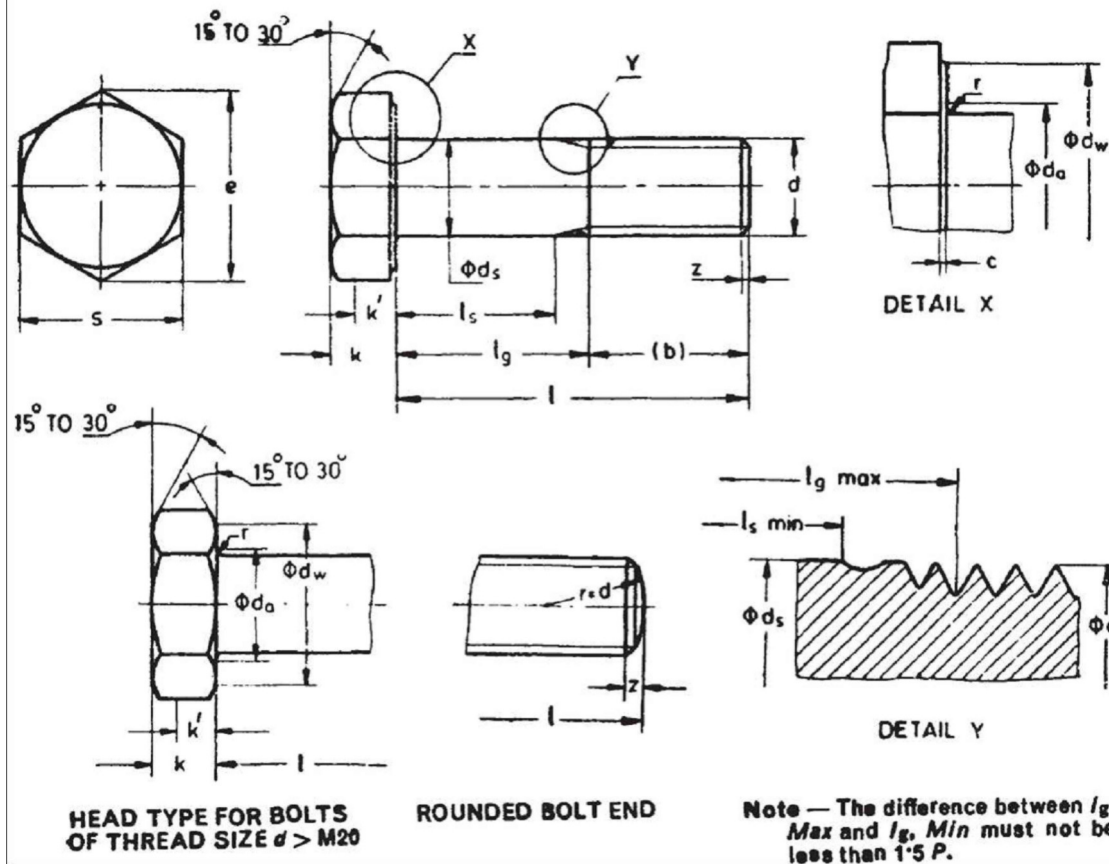

HEAD TYPE FOR BOLTS OF THREAD SIZE $d > M20$

ROUNDED BOLT END

Note — The difference between l_g , Max and l_g , Min must not be less than $1.5 P$.

HSFG BOLT FIGURE AS GIVEN IN IS-3757 STANDARD

Sl.No	Bolt Variant	l (mm)	b (mm)	lg (mm)	Bolt head color
1	M20X60-Extended	60	55	5	MAGENTA
2	M20X90-Extended	90	70	20	GREEN
3	M20X130-Extended	130	70	60	ORANGE
4	M20X160-Extended	160	70	90	INDIGO

NOTES:

1. THE THREADED PORTION AND SHANK LENGTH ARE TO BE FOLLOWED AS PER TABLE
2. OTHER DIMENSIONS ARE AS PER IS-3757 STANDARD
3. BOLTS PROPERTY CLASS 8.8.

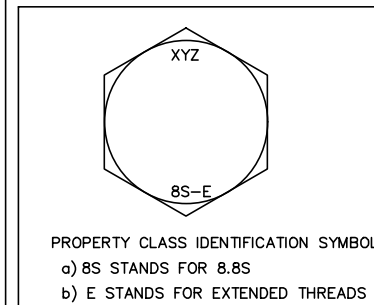

CAUTION: The information on this document is the property of BHARAT HEAVY ELECTRICALS LTD. It must not be used directly or indirectly in any way detrimental to the interest of the company.

TYPE OF PRODUCT
OR NAME OF
CUSTOMER/PROJECT

 Bharat Heavy Electricals Ltd
UNIT: HIGH PRESSURE BOILER PLANT
TIRUCHIRAPALLI - 620014
355-055

DRN	NAME	SIGNATURE	DATE
	S.SETHUPATHI		30.04.2022
CHD	KRG/MPN/VRS/AGN/YUVA		30.04.2022
APPD	K.RAJMOHAN		30.04.2022

DEPT	ST	ALL DIMENSIONS ARE IN MM	PROJECTION	SCALE	WEIGHT (Kg)	REF TO ASSY / OLD DWG
	CODE 122					

TITLE
M20X60,90,130&160-EXTENDED
THREAD-HSFG BOLTS

DRAWING NO :
3-35-700-09998

REV
00

REV	DATE	ALTERED :
01		CHD & APPD:

DRAWING NO:
3-35-700-06802

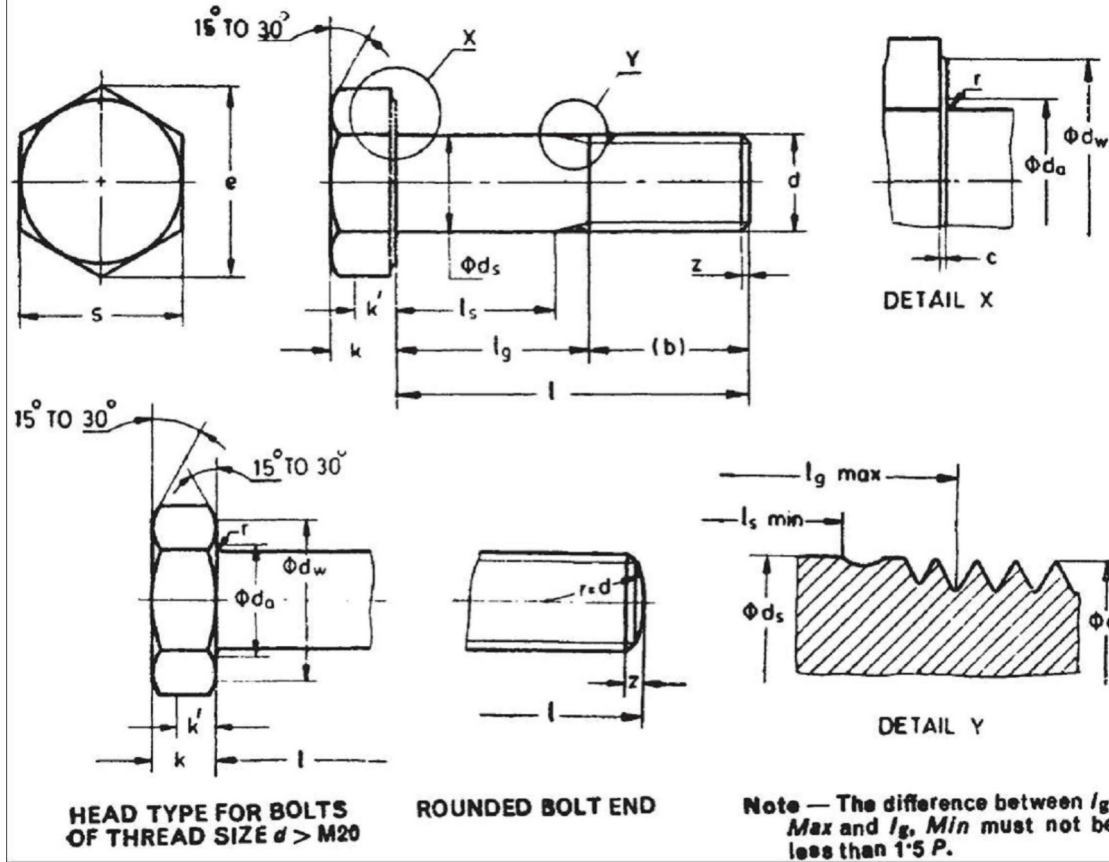

HEAD TYPE FOR BOLTS
OF THREAD SIZE $d > M20$

ROUNDED BOLT END

Note — The difference between l_g ,
Max and l_g , Min must not be
less than $1.5 P$.

HSFG BOLT FIGURE AS GIVEN IN IS-3757 STANDARD

Sl.No	Bolt Variant	l (mm)	b (mm)	lg (mm)	Bolt head color
1	M24X70-Extended	70	65	5	Red
2	M24X90-Extended	90	70	20	Green
3	M24X130-Extended	130	80	50	Orange
4	M24X170-Extended	170	80	90	Blue
5	M24X200-Extended	200	80	120	Yellow

NOTES:

1. THE THREADED PORTION AND SHANK LENGTH ARE TO BE FOLLOWED AS PER TABLE
2. OTHER DIMENSIONS ARE AS PER IS-3757 STANDARD
3. BOLTS PROPERTY CLASS 8.8.

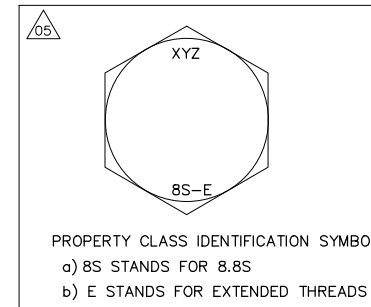

REV 06	DATE 28.10.2023	ALTERED : PRAVEEN	REV 03	DATE 25-04-2019	ALTERED : K.S.PANDIAN
		CHD & APPD: GANESAN			CHD & APPD: MUTHU.S
		M24X200 - EXTENDED ADDED.			SKETCH RESIZED
REV 05	DATE 21.10.2022	ALTERED : R.GOVINDASAMY	REV 02	DATE 16.08.2018	ALTERED : SHAILESH
		CHD & APPD: S.MUTHU			CHD & APPD: MPN/MUTHU.S
		PROPERTY CLASS IDENTIFICATION SYMBOL ADDED.			NOTES NO.03 ADDED.
REV 04	DATE 01.11.2019	ALTERED : K.PRAKASH	REV 01	DATE 21.07.2018	ALTERED : MUTHU
		CHD & APPD: YUVARAJ.S			CHD & APPD: SARAVANA
		TABLE UPDATED WITH COLOR REQUIREMENT ON BOLT HEAD			DIMENSIONS UPDATED IN FIGURE

CAUTION: The information on this document is the property of BHARAT HEAVY ELECTRICALS LTD. It must not be used directly or indirectly in any way detrimental to the interest of the company.

TYPE OF PRODUCT
OR NAME OF
CUSTOMER/PROJECT



Bharat Heavy Electricals Ltd
UNIT: HIGH PRESSURE BOILER PLANT
TIRUCHIRAPALLI - 620014

DEPT	ST	PROJECTION	SCALE	WEIGHT (Kg)	REF TO ASSY / OLD DWG
CODE 122	ALL DIMENSIONS ARE IN MM				
TITLE					DRAWING NO :
M24X70,90,130 170-EXTENDED THREAD-HSFG BOLTS					3-35-700-06802
					REV
					06

DRAWING NO:
3-35-700-09999

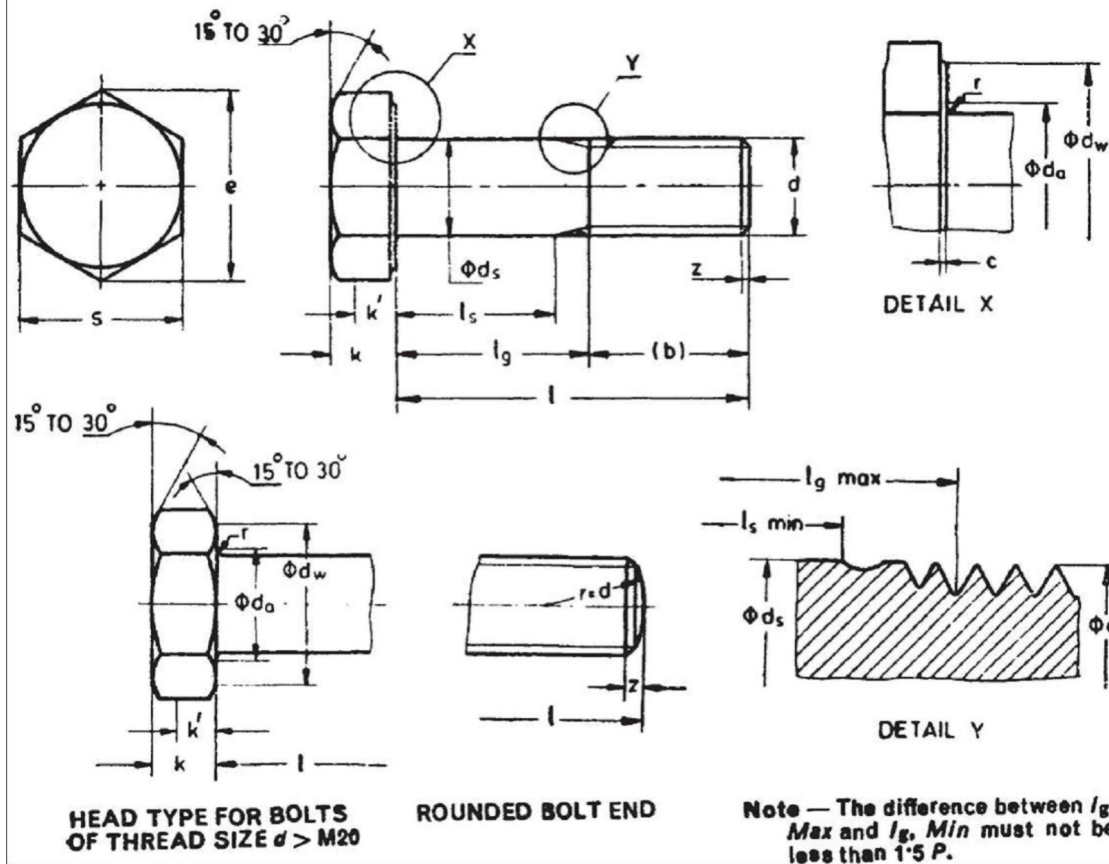

HEAD TYPE FOR BOLTS OF THREAD SIZE $d > M20$

ROUNDED BOLT END

Note — The difference between l_g , Max and l_g , Min must not be less than $1.5 P$.

HSFG BOLT FIGURE AS GIVEN IN IS-3757 STANDARD

Sl.No	Bolt Variant	l (mm)	b (mm)	lg (mm)	Bolt head color
1	M30X90-Extended	90	70	20	GREEN
2	M30X130-Extended	130	80	50	ORANGE
3	M30X170-Extended	170	90	80	BLUE
4	M30X200-Extended	200	80	120	YELLOW

NOTES:

1. THE THREADED PORTION AND SHANK LENGTH ARE TO BE FOLLOWED AS PER TABLE
2. OTHER DIMENSIONS ARE AS PER IS-3757 STANDARD
3. BOLTS PROPERTY CLASS 10.9.

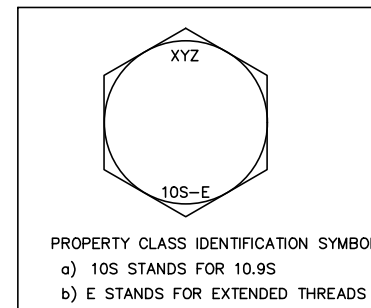

CAUTION: The information on this document is the property of BHARAT HEAVY ELECTRICALS LTD. It must not be used directly or indirectly in any way detrimental to the interest of the company.

TYPE OF PRODUCT OR NAME OF CUSTOMER/PROJECT

 Bharat Heavy Electricals Ltd UNIT: HIGH PRESSURE BOILER PLANT TIRUCHIRAPALLI - 620014 355-055	DRN	NAME S.SETHUPATHI	SIGNATURE	DATE 30.04.2022
	CHD	KRG/MPN/VRS/AGN/YUVA		30.04.2022
	APPD	K.RAJAMOHAN		30.04.2022

DEPT ST	ALL DIMENSIONS ARE IN MM	PROJECTION 	SCALE	WEIGHT (Kg)	REF TO ASSY / OLD DWG
CODE 122					

TITLE M30X90,130,170&200-EXTENDED THREAD-HSFG BOLTS	DRAWING NO : 3-35-700-09999	REV 00
---	--------------------------------	-----------

REV	DATE	ALTERED :
01		CHD & APPD:

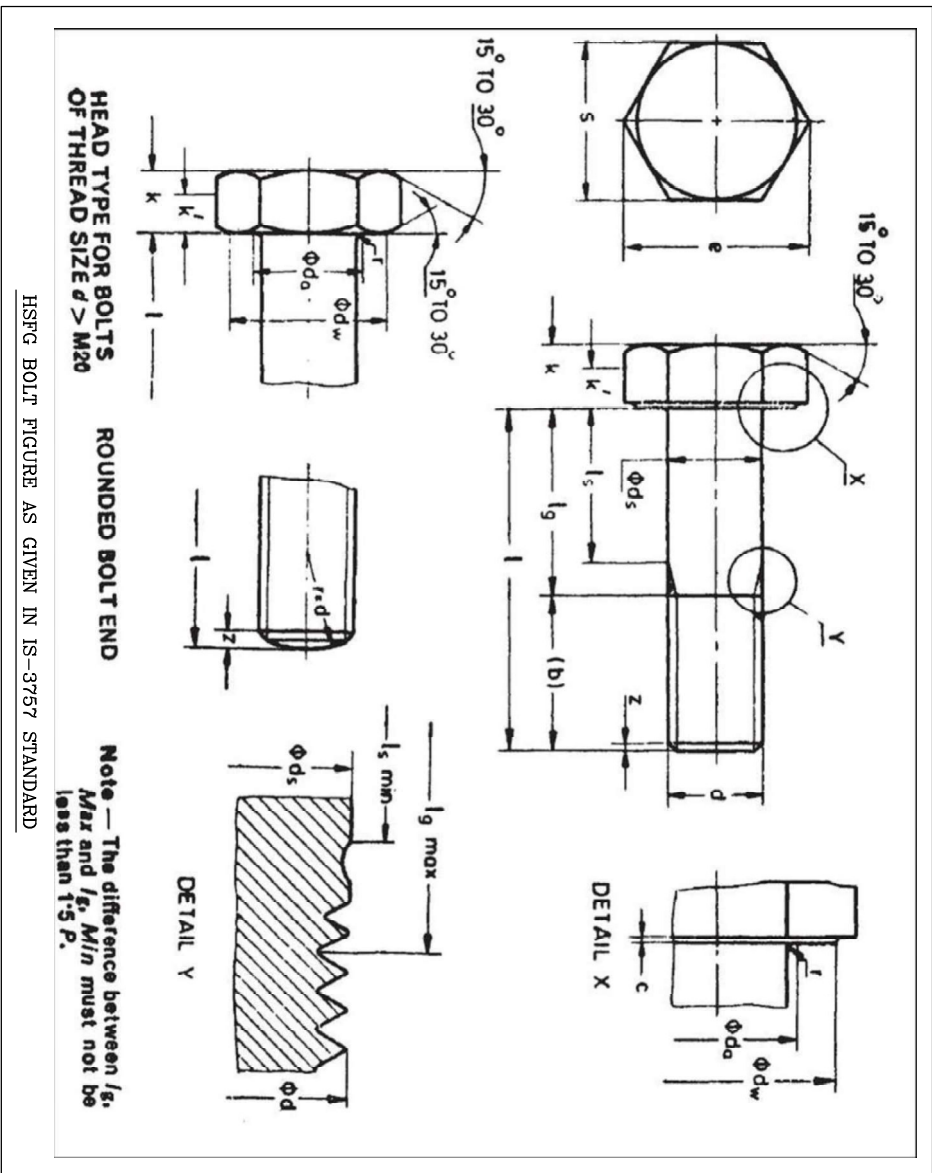

Sl.No.	Bolt Variant	l(mm)	b(mm)	lg(mm)	Bolt head colour
1	M36X100-Extended	100	85	15	GREEN
2	M36X120-Extended	120	85	35	ORANGE
3	M36X140-Extended	140	95	45	BLUE
4	M36X160-Extended	160	95	65	YELLOW
5	M36X190-Extended	190	105	85	RED

- NOTES:
1. THE THREADED PORTION AND SHANK LENGTH ARE TO BE FOLLOWED AS PER TABLE
 2. OTHER DIMENSIONS ARE AS PER IS-3757 STANDARD
 3. BOLTS PROPERTY CLASS 10.9.

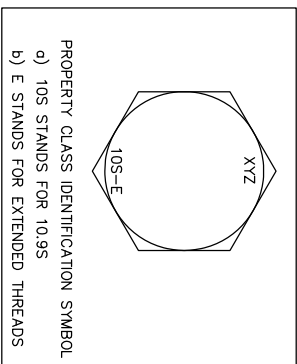

HSFG BOLT FIGURE AS GIVEN IN IS-3757 STANDARD

HEAD TYPE FOR BOLTS OF THREAD SIZE $d > M20$

ROUNDED BOLT END

Note - The difference between l_g , Max and l_g , Min must not be less than $1.5 P$.

CAUTION: The information on this document is the property of BHARAT HEAVY ELECTRICALS LTD. It must not be used directly or indirectly in any way detrimental to the interest of the company.

REV	DATE	ALTERED :
01		CHD & APPD:

TYPE OF PRODUCT OR NAME OF CUSTOMER/PROJECT		Bharat Heavy Electricals Ltd UNIT: HIGH PRESSURE BOILER PLANT TIRUCHIRAPALLI - 620014	
DEPT CIVIL	ALL DIMENSIONS ARE IN MM	PROJECTION	SCALE
CODE 497			WEIGHT (Kg)
356-055			
DRN	NAME	SIGNATURE	DATE
CHD	JKU		14.02.2024
APPD	JKU/PC/KD/NK/KC/RK		14.02.2024
	THSR		14.02.2024
REF TO ASSY / OLD DWG		DRAWING NO :	
		0-86-700-A0323	

TITLE
 M36X100,120,140,160&190-EXTENDED
 THREAD-HSFG BOLTS

REV

00

Revision record:

Rev 00: 18/10/2011 Fresh Issue released and Test Sampling Plan Rev 00

Rev 01: 19/04/2012 Cl 2: Requirement if the Carbon content is below 0.6% - Added for Bolts; Mn for Nuts: limited to 0.25 min instead of 0.25 max. Cl 5: Hardness of Bolt & Nut: Acceptance values changed. Cl 7: Preservation and Packing added and Test Sampling Plan Rev 01

Rev 02: 28/10/2014 Property class Bolt 10.9 and Nut 10 and its requirements added (for Neyveli 2x500MW Tower boiler) in all clauses and Test Sampling Plan Rev 02

1. SCOPE:

This technical delivery condition covers the requirements for the High strength structural steel bolts, Nuts and Washers applicable for boiler structures and shall be procured from the BHEL approved manufacturers only. The mandatory requirements, test methods and procedures from the applicable IS standards to confirm a product to its relevant latest IS standard shall be met with. TDC is in addition to specification.

Size, Specification and Qty: As per the BHEL Purchase order (PO) / BHEL Drawing. The bolts, nuts and washers shall be supplied in the dull black heat treated condition with residual coating of light oil.

For Bolts: IS: 3757 (Latest) Property class: 8.8 or 10.9. Product Grade C of IS Specification IS: 1367 Part 2 (Latest).

For Nuts: IS: 6623 (Latest) Property class: 8 or 10, Product Grade B

For Washers: IS: 6649 (Latest) Material: 45C8, Type-A: Plain hole Circular Washers. Grade: Ordinary

2. RAW MATERIAL:

- Bolts and Nuts: Rolled/Forged bar of Carbon steel. Washer: as per IS 1571 Part 2 (Latest)
- **Chemical composition:** Shall be checked on receipt of raw material at supplier works for every heat
 Bolts: Plain Carbon Steel, Carbon steel with additives (eg Br, Mn or Cr) – As per Table 2 of IS: 1367 Part 3 (Latest)
 Nuts: As per Table 4 of IS 1367 Part 6 (Latest)
 Washers: As per IS 1570 Part 2 and Sulphur, Phosphorous <0.06% in check analysis

3. DIMENSIONS AND TOLERANCES:

- Process: Cold/Hot Forging with Dies and tools clean of loose scale and sheet particles.
- Threads on the bolts shall be checked with a properly calibrated ring gauge with a tolerance class 6g. Threads on the nuts shall be checked with a properly calibrated plug gauge with tolerance class 6H (in an NABL accredited LAB).
- Dimensions of the Bolts shall be as per the table given in IS 3757 (Latest)
- Dimensions of the Nuts shall be as per the table given in IS: 6623 (Latest)
- Dimensions of the Washers shall be as per the table given in IS 6649 (Latest)

Note: The washers shall be flat with a maximum deviation not exceeding 0.25 mm from the straight edge laid along a line passing through the center of the hole. The hole of the washer shall be concentric with the outside dimensions within 0.50 mm. washers are required to be clipped to provide clearance, the clipped edge shall not be closer to the center of the washer than 0.9 of the bolt diameter.

4. Post Forming Heat Treatment (HT):

- Bolt: After forming shall be quenched (HT at AC 3 temperature, with soaking time 30minutes per inch followed by quenching) and tempered (at 425°C min, 60 minutes per inch). There should be a sufficient hardenability to ensure a structure consisting of approximately 90 % martensitic in the core of the threaded sections for the fasteners in the as-hardened condition before tempering.
- Nut: Shall be hardened and then tempered (at a temperature of 425°C minimum).
- Washer: Shall be hardened and tempered. Carburized washers are not permitted.

5. CHEMICAL & MECHANICAL & NDE: (on Heat Treated finished product)

Sample Size for Mechanical test: & NDE: As per Sampling Plan

BOLT :

Sl	Test	Test Method - As per Table 3 of IS: 1367 Part 3 (Latest)	Acceptance
1	Chemistry	Spectro / Wet Analysis Method – One sample for every heat Of raw material and One sample/HT batch on product	As per Cl 2.0 of this TDC
2	Hardness Test	Note: Surface hardness shall not be more than 30 Vickers above the measured core Hardness on the product when readings of both surface and core are carried out at HV 0.30. For property class 10.9, any increase in hardness at the surface which indicates that the surface hardness exceeds 390 HV is not acceptable.	8.8 – Min 255 HV Max 335 HV 10.9 – Min 320HV, Max 380HV
3	Minimum Tensile Strength, %Elongation on 5.65√A, % Reduction in Area after fracture	*if wedge load test is satisfactory the axial tensile test is not required	8.8 – 830N/mm ² , 12 min, 52% min 10.9 – 1040 N/mm ² , 9 min, 48% min
4	Proof Load Test	8.8 – Proof Load of M16(91KN), M20 (147KN), M24 (212KN), M30 (337KN), M36 (490KN); 10.9 – Proof Load of M16(130KN), M20 (203KN), M24 (293KN), M30 (466KN), M36 (678KN) shall be applied axially to the bolt in a calibrated tensile testing machine for 15sec.	Length of the bolt after loading shall be the same as before loading within a tolerance of ± 12.5 µm allowed for measurement error.
5	Strength under Wedge load test	IS: 1367 Part 3 (Latest)	8.8 – < 830N/mm ² 10.9 – < 1040 N/mm ²
6	Decarburization Test at 200X min magnification	Determination of the following by MICROSCOPIC Method a)Minimum Height of non decarburized thread zone – E b)Maximum depth of complete decarburization – G	E = 2/3 H1 G = 0.015 mm
7	Hardness after Retempering	IS: 1367 Part 3 (Latest) # test not mandatory, to be applied in case of dispute only	Reduction of hardness 20 HV max.
8	NDE for Surface Integritiy	before machining – For bar Diameter ≥ 40 mm: UT as per ASTM A388. For bar Diameter < 40 mm: MPI as per ASTM E 709 After machining – MPI as per ASTM E 709 or as per ISO 6157 Part 3 (Latest)	UT – ASME SEC-VIII. Div-II Part: 3.3.4 (Latest). MPI – Linear indications like cracks, folds & other injurious defects are notacceptable.

9	Micro Examination for Surface Integrity – Laps at threaded region.	<p>If any defectives found in visual and NDE examinations, the extent of defect can be determined by micro examination.</p>	<p>Max depth of laps in thread = 0.41 mm Laps of any depth or length are not permitted in the following places:</p> <ul style="list-style-type: none"> at the root of the thread at the loaded flank of screw thread below the pitch diameter, even if they start beyond the pitch diameter. <p>The following laps are permissible :</p> <ul style="list-style-type: none"> laps in the crest of the threads of 0.25 H1 max.; crest of the threads not entirely rolled out, maximum half a turn on one thread; laps below the pitch diameter, if they run on the non-loaded flank towards the major diameter and not deeper than 0.25 H1 and not longer than half a turn on one thread.
---	--	---	--

NUT: (on Heat Treated finished product)

Sl	Test	Test Method	Acceptance Value
1.	Chemistry	Spectro / Wet Analysis Method – For every heat Of raw material and, One sample/HT batch on product	As per Cl 2.0 of this TDC
2.	Hardness Test	Hardness of the test mandrel shall be minimum 45 HRC.	8S – Min 188 HV Max 372 HV 10S – Min 272 HV Max 372 HV
3.	Proof Load Test	Proof Load of 8S – M16(168.9KN), M20 (263.4KN), M24 (379.5KN), M30 (603.1KN), M36 (878.3KN) 10S – M16(195.5KN), M20 (305KN), M24 (439.5KN), M30 (698.4KN), M36 (1017.2KN) shall be applied axially to the nut in a tensile testing machine for 15sec.	The nut shall resist the load without failure by stripping or rupture, and shall be removable by the fingers after the load is released.
4.	NDE for Surface Integrity	Before coating, as per IS 1367 Part 10 Cl 4.2 (Latest)	Linear indications like cracks, folds & Other injurious defects are not acceptable.

WASHER: As per IS 5369. The washers shall be free from cracks, burrs, pits and other defects. All sharp edges shall be removed. **(on Heat Treated finished product)**

Sl	Test	Test Method	Acceptance Value
1.	Chemistry	Spectro / Wet Analysis Method – For every heat Of raw material and One sample/HT batch on product.	As per Cl 2.0 of this TDC
2.	Hardness Test	IS 1586 (latest)	Min 35 HRC Max 45 HRC

6. MARKING, PRESERVATION AND PACKING:

The following to be hot stamped or embossed on the top surface of the bolt and nut:
Bolt – Manufacturer’s Identification Symbol and 8.8S/10.9S
Nut – Manufacturer’s Identification Symbol and 8S/ 10S

Washers – Shall be identified by – the provision of 2 nibs and manufacturers identification symbol being placed as near to the outer edge as possible.

The following details shall be clearly indicated in the tags tied to the bundle:

- Customer Name
- Manufacturer’s Name
- Vendor Code
- Purchase Order No and Supplier internal W.O No
- Quantum and Weight
- BHEL Material Code
- Item Description with diameter, length

Shall be packed in bituminous coated Polythene lined Hessian Cloth/Bag. Each bag shall contain only the same size of bolts/ nuts/ washers respectively and the same shall be indicated in the tags.

7. INSPECTION AND CERTIFICATION:

All the finished components shall be visually and dimensionally inspected as per sampling plan. All the test results shall be documented and maintained. Products to be inspected at works & test certificates (in English) shall be submitted with the following details counter signed by BHEL/BHEL Authorized Inspection agency as indicated in the PO. Manufacturers Test certificate (MTC) shall contain the following:

- Purchase Order No. (BHEL), TDC No, Specification and Grade.
- Name of raw material bar supplier.
- Forming process
- Dimensional reports for each product.
- Chemistry including incidental elements on the raw material and final product checked in NABL lab/ suppliers own lab.
- HT details of materials temperature, soaking time, ROH/ROC medium etc.
- All Mechanical test result report including hardness.
- MPL, Micro examination and decarburization test report with the reference & acceptance standard.
- TC of raw material, UT/MPI report done on raw material shall accompany the MTC.

8. AUDITS AT BHEL:

BHEL reserve the right to reject any item found to be not meeting the requirements during tests at supplier works or during subsequent processing at BHEL.

Haritha.C QA	Venkanna Rupani QA	Kalyanaraman.V QA	Viswanathan.D Engineering	Sekar.S QC	Balachandran.K.S MM	Revisankaran.U QA
Prepared By			Reviewed By			Approved By

BHEL: TRICHY - 14

TEST SAMPLING PLAN FOR HSFG BOLTS, NUTS & WASHERS AS PER BHEL TDC: 5:211 Rev 02

Lot Size (In nos.)	SAMPLE SIZE										Remarks
	Visual (nos.)	Dimensional (nos.)	MPI (nos.)	Physical Tests					Min Tensile Strength (nos.)	Decarb (nos.)	
				Total nos.	Hardness (nos.)	Hardness after Re-tempering (nos.)	Proof Load (nos.)	Wedge Load (nos.)			
Upto 100	20	8	15	5	5	2	2	2	2	1	
101 to 300	32	13	15	5	5	2	2	2	2	1	
301 to 500	50	20	15	5	5	2	2	2	2	1	
501 to 1000	80	32	15	5	5	2	2	2	2	1	
1001 to 3000	125	50	25	8	8	2	2	4	2	1	Upto 1500 nos. 15 nos. for MPI
3001 to 10000	200	80	50	13	13	2	2	6	2	1	Upto 5000 nos. 25 nos. for MPI
10001 to 35000	315	125	75	20	20	4	4	10	4	2	Upto 15000 nos. 50 nos. for MPI
Above 35000	500	200	100	32	32	6	6	15	6	3	Upto 50000 nos. 75 nos. for MPI
Inspection by BHEL/BHEL AIA	W	W	W	W	W	W	W	W	W	W	

Remarks:

- Acceptance Number is zero. If the sample is having deviations in Visual, Dimensional and MPI then the entire lot shall be 100% inspected. In case of deviations in Physical tests a second sample of twice the sample size of initial sample shall be taken. The lot will get rejected if the second sample fails.
- Preservation & Packing: The bolts shall be supplied in the dull black heat treated condition with a residual coating of light oil. Finished products shall be packed in a bituminous coated Polythene lined Hessian cloth/bag. Each bag shall contain only the same size of bolts/nuts/washers respectively and the same shall be indicated in the tags.
- Inspection by BHEL / BHEL AIA shown as "W" shall be witnessed for the sample size indicated against the lot size.

<i>[Signature]</i> 28/10/14	R. Venkanna 28/10/2014	<i>[Signature]</i> 28/10/2014	<i>[Signature]</i> 28/10/14	<i>[Signature]</i> 28/10/14
Haritha.C QA	Venkanna Rupani QA	Kalyanaraman.V QA	Sekar.S QC	Revisankaran.U QA
Prepared By		Reviewed By		
Approved By		Approved By		

	BHEL – Tiruchirappalli - 620014, India. Quality Assurance Department TECHNICAL DELIVERY CONDITIONS	DOC No: TDC:5:215 Rev: 01 Effective Date: 12/08/2022 Page: 1 of 6
Product: Extended Thread High Strength Friction Grip Fasteners For Structurals (Property class Bolt 8.8,10.9/ Nut 8 &10)		

Revision record:

Rev 00: Dt 14/11/2019 – Fresh issue

Rev01 : Dt 12/08/2022 –In clause 1.0,5.0,6.0, class 10.9 for bolts & 10 for nuts included, Drawing no’s removed in Clause 1.0,3.0 &6.0. Weight of bags included in Cl 6.0

1. SCOPE:

This technical delivery condition covers the requirements for the High strength structural steel bolts, Nuts and Washers applicable for boiler structures and shall be procured from the BHEL approved manufacturers only. The mandatory requirements, test methods and procedures from the applicable IS standards to confirm a product to its relevant latest IS standard shall be met with. TDC is in addition to specification.

Size, Specification and Qty: As per the BHEL Purchase order (PO) / BHEL Drawing. The bolts, nuts and washers shall be supplied in the dull black heat treated condition with residual coating of light oil.

For Bolts: As per BHEL drawing as indicated in the Purchase order.

and IS: 3757 (Latest) Property class: 8.8,10.9. Product Grade C of IS Specification IS: 1367 Part 2 (Latest).

For Nuts: IS: 6623 (Latest) Property class: 8 & 10, Product Grade B

For Washers: IS: 6649 (Latest) Material: 45C8, Type-A: Plain hole Circular Washers. Grade: Ordinary

2. RAW MATERIAL:

- **Bolts and Nuts:** Rolled/Forged bar of Carbon steel. Washer: as per IS 1571 Part 2 (Latest)
- **Chemical composition:** Shall be checked on receipt of raw material at supplier works for every heat
Bolts: Plain Carbon Steel, Carbon steel with additives (e.g. Br, Mn or Cr) – As per Table 2 of IS: 1367 Part 3 (Latest)
Nuts: As per Table 4 of IS 1367 Part 6 (Latest)
Washers: As per IS 1570 Part 2 and Sulphur, Phosphorous <0.06% in check analysis

3. DIMENSIONS AND TOLERANCES:

- **Process:** Cold/Hot Forging with Dies and tools clean of loose scale and sheet particles.
- Threads on the bolts shall be checked with a properly calibrated ring gauge with a tolerance class 6g. Threads on the nuts shall be checked with a properly calibrated plug gauge with tolerance class 6H in an NABL accredited LAB.
- Dimensions of the Bolts shall be as per BHEL drawing as indicated in the Purchase order.
- Dimensions of the Nuts shall be as per the table given in IS: 6623 (Latest)
- Dimensions of the Washers shall be as per the table given in IS 6649 (Latest)

Note: The washers shall be flat with a maximum deviation not exceeding 0.25 mm from the straight edge laid along a line passing through the center of the hole. The hole of the washer shall be concentric with the outside dimensions within 0.50 mm. washers are required to be clipped to provide clearance, the clipped edge shall not be closer to the center of the washer than 0.9 of the bolt diameter.

4. Post Forming Heat Treatment (HT):

- **Bolt:** After forming shall be quenched (HT at AC 3 temperature, with soaking time 30minutes per inch followed by quenching) and tempered (at 425°C min, 60 minutes per inch). There should be a sufficient hardenability to ensure a structure consisting of approximately 90 % martensitic in the core of the threaded sections for the fasteners in the as-hardened condition before tempering.
- **Nut:** Shall be hardened and then tempered (at a temperature of 425°C minimum).
- **Washer:** Shall be hardened and tempered. Carburized washers are not permitted.

	BHEL – Tiruchirappalli - 620014, India. Quality Assurance Department TECHNICAL DELIVERY CONDITIONS	DOC No: TDC:5:215 Rev: 01 Effective Date: 12/08/2022 Page: 2 of 6
	Product: Extended Thread High Strength Friction Grip Fasteners For Structurals (Property class Bolt 8.8,10.9/ Nut 8 &10)	

5. CHEMICAL & MECHANICAL & NDE: (on Heat Treated finished product)

Sample Size for Mechanical test: & NDE: As per Sampling Plan

BOLT :

Sl	Test	Test Method - As per Table 3 of IS: 1367 Part 3 (Latest)	Acceptance
1	Chemistry	Spectro / Wet Analysis Method – One sample for every heat Of raw material and One sample/HT batch on product	As per CI 2.0 of this TDC
2	Hardness Test	Note: Surface hardness shall not be more than 30 Vickers above the measured core Hardness on the product when readings of both surface and core are carried out at HV 0.30.	8.8 – Min 255 HV Max 335 HV 10.9- Min 320 HV Max 380 HV
3	Minimum Tensile Strength, %Elongation on 5.65VA, % Reduction in Area after fracture	if wedge load test is satisfactory the axial tensile test is not required	8.8 – 830N/mm ² , 12 min, 52% min 10.9-1040N/mm ² , 9 min, 48% min
4	Proof Load Test	8.8 – Proof Load of M20 (147KN), M24 (212KN), M30 (337KN), M36 (490KN) 10.9 – Proof Load of M20 (203KN), M24 (293KN), M30 (466KN), M36 (678)KN	Length of the bolt after loading shall be the same as before loading within a tolerance of $\pm 12.5 \mu\text{m}$ allowed for measurement error.
5	Strength under Wedge load test	IS: 1367 Part 3 (Latest)	8.8 – 830N/mm ² 10.9– 1040 N/mm ²
6	Decarburization Test at 200X min magnification	Determination of the following by MICROSCOPIC Method a) Minimum Height of non decarburized thread zone – E b) Maximum depth of complete decarburization – G	E = 2/3 H1 G = 0.015 mm
7	Hardness after Retempering	IS: 1367 Part 3 (Latest) test not mandatory, to be applied in case of dispute only	Reduction of hardness 20 HV max.
8	NDE for Surface Integrity	before machining – For bar Diameter ≥ 40 mm: UT as per ASTM A388. For bar Diameter < 40 mm: MPI as per ASTM E 709 After machining – MPI as per ASTM E 709 or as per ISO 6157 Part 3 (Latest)	UT – ASME SEC-VIII. Div-II Part: 3.3.4 (Latest). MPI – Linear indications like cracks, folds & other injurious defects are not acceptable.
9	Micro Examination for Surface Integrity – Laps at threaded region.	If any defectives found in visual and NDE examinations, the extent of defect can be determined by micro examination.	Max depth of laps in thread = 0.41 mm Laps of any depth or length are not permitted in the following places: <ul style="list-style-type: none"> • at the root of the thread • at the loaded flank of screw thread below the pitch



Product: Extended Thread High Strength Friction Grip Fasteners For Structurals (Property class Bolt 8.8,10.9/ Nut 8 &10)

		<p>diameter, even if they start beyond the pitch diameter. The following laps are permissible :</p> <ul style="list-style-type: none"> laps in the crest of the threads of 0.25 H1 max.; crest of the threads not entirely rolled out, maximum half a turn on one thread; laps below the pitch diameter, if they run on the non-loaded flank towards the major diameter and not deeper than 0.25 H1 and not longer than half a turn on one thread.
--	--	---

NUT: (on Heat Treated finished product)

Sl	Test	Test Method	Acceptance Value
1.	Chemistry	Spectro / Wet Analysis Method – For every heat of raw material and, One sample/HT batch on product	As per Cl 2.0 of this TDC
2.	Hardness Test	Hardness of the test mandrel shall be minimum 45 HRC.	Min 272 HV Max 372 HV
3.	Proof Load Test	Proof Load of 8S – Proof Load of M20 (263.4KN), M24 (379.5KN), M30 (603.1KN), M36 (878.3KN) 10S -M20 (305KN), M24 (439.5KN), M30 (698.4KN), M36 (1017.2KN) shall be applied axially to the nut in a tensile testing machine for 15sec.	The nut shall resist the load without failure by stripping or rupture, and shall be removable by the fingers after the load is released.
4.	NDE for Surface Integrity	Before coating, as per IS 1367 Part 10 Cl 4.2 (Latest)	Linear indications like cracks, folds & Other injurious defects are not acceptable.

WASHER: As per IS 5369. The washers shall be free from cracks, burrs, pits and other defects. All sharp edges shall be removed.

Sl	Test	Test Method	Acceptance Value
1.	Chemistry	Spectro / Wet Analysis Method – For every heat Of raw material and One sample/HT batch on product.	As per Cl 2.0 of this TDC
2.	Hardness Test	IS 1586 (latest)	Min 35 HRC Max 45 HRC

	BHEL – Tiruchirappalli - 620014, India. Quality Assurance Department TECHNICAL DELIVERY CONDITIONS	DOC No: TDC:5:215 Rev: 01 Effective Date: 12/08/2022 Page: 4 of 6
Product: Extended Thread High Strength Friction Grip Fasteners For Structurals (Property class Bolt 8.8,10.9/ Nut 8 &10)		

6. MARKING, PRESERVATION AND PACKING:

The following to be hot stamped or embossed on the top surface of the bolt and nut:

Bolt – Manufacturer’s Identification Symbol and 8.8S,10.9S

Nut – Manufacturer’s Identification Symbol and 8S,10S

Washers – Shall be identified by – the provision of 2 nibs and manufacturers identification symbol being placed as near to the outer edge as possible.

The following details shall be clearly indicated in the tags tied to the bundle:

1) Customer Name 2) Manufacturer’s Name 3) Vendor Code 4) Purchase Order No and Supplier Internal W.O No 5) Quantity and Weight 6) BHEL Material Code 7) Item Description with diameter, length

Colour coding: To be done only on bolt head as per BHEL drawing as indicated in the Purchase order.

Shall be packed in bituminous coated Polythene lined Hessian Cloth/Bag. Each bag shall contain only the same size of bolts/ nuts/ washers respectively and the same shall be indicated in the tags. The weight of the bag shall not exceed 30Kgs.

7. INSPECTION AND CERTIFICATION:

All the finished components shall be visually and dimensionally inspected as per sampling plan. All the test results shall be documented and maintained. Products to be inspected at works & test certificates (in English) shall be submitted with the following details counter signed by BHEL/BHEL Authorized Inspection agency as indicated in the PO. Manufacturers Test certificate (MTC) shall contain the following:

- 1) Purchase Order No. (BHEL), TDC No, Specification and Grade.
- 2) Name of raw material bar supplier.
- 3) Forming process
- 4) Dimensional reports for each product.
- 5) Chemistry including incidental elements on the raw material and final product checked in NABL lab/ suppliers own lab.
- 6) HT details of materials temperature, soaking time, ROH/ROC medium etc.
- 7) All Mechanical test result report including hardness.
- 8) MPI, Micro examination and decarburization test report with the reference & acceptance standard.
- 9) TC of raw material, UT/MPI report done on raw material shall accompany the MTC.

8. AUDITS AT BHEL:

BHEL reserve the right to reject any item found to be not meeting the requirements during tests at supplier works or during subsequent processing at BHEL.

	BHEL – Tiruchirappalli - 620014, India.	DOC No: TDC:5:215 Rev: 01
	Quality Assurance Department	Effective Date: 12/08/2022
TECHNICAL DELIVERY CONDITIONS		Page: 5 of 6
Product: Extended Thread High Strength Friction Grip Fasteners For Structurals (Property class Bolt 8.8,10.9/ Nut 8 &10)		

TEST SAMPLING PLAN FOR HSFG BOLTS, NUTS & WASHERS FOR BHEL TDC: 5:215

Lot Size (In nos.)	SAMPLE SIZE										Remarks
	Visual (nos.)	Dimensional (nos.)	MPI (nos.)	Physical Tests							
				Total nos.	Hardness (nos.)	Hardness after Re- tempering (nos.)	Proof Load (nos.)	Wedge Load (nos.)	Min Tensile Strength (nos.)	Decarb (nos.)	
Upto 100	20	8	15	5	5	5	2	2	2	1	
101 to 300	32	13	15	5	5	5	2	2	2	1	
301 to 500	50	20	15	5	5	5	2	2	2	1	
501 to 1000	80	32	15	5	5	5	2	2	2	1	
1001 to 3000	125	50	25	8	8	8	2	4	2	1	Upto 1500 nos. 15 nos. for MPI
3001 to 10000	200	80	50	13	13	13	2	6	2	1	Upto 5000 nos. 25 nos. for MPI
10001 to 35000	315	125	75	20	20	20	4	10	4	2	Upto 15000 nos. 50 nos. for MPI
Above 35000	500	200	100	32	32	32	6	15	6	3	Upto 50000 nos. 75 nos. for MPI
Inspection by BHEL/BHEL AIA	W	W	W		W	W	W	W	W	W	

Inspection by BHEL / BHEL AIA shown as “W” shall be witnessed for the sample size indicated against the lot size







BHEL – Tiruchirappalli - 620014,
India. Quality Assurance Department
TECHNICAL DELIVERY
CONDITIONS

DOC No: TDC:5:215 Rev: 01
Effective Date: 12/08/2022
Page: 6 of 6

Product: Extended Thread High Strength Friction Grip Fasteners For Structural (Property class Bolt 8.8,10.9/ Nut 8 &10)

Remarks:

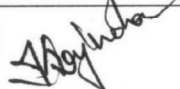
1. Acceptance Number is zero. If the sample is having deviations in Visual, Dimensional and MPI then the entire lot shall be 100% inspected. In case of deviations in Physical tests a second sample of twice the sample size of initial sample shall be taken. The lot will get rejected if the second sample fails.
2. Preservation & Packing: The bolts shall be supplied in the dull black heat treated condition with a residual coating of light oil. Finished products shall be packed in a bituminous coated Polythene lined Hessian cloth/bag. Each bag shall contain only the same size of bolts/nuts/washers respectively and the same shall be indicated in the tags.

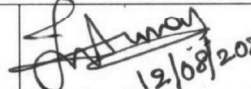
				 12/08/2022
M. Jeyaram Manager/QA	S Anand Kumar/SDGM MM	K Rajmohan SDGM/Engg	T Pandian AGM/QC	J.V.V. Aruna Kumar AGM/QA &BE
Prepared	Reviewed			Approved

		BHEL: IVP Goindwal		STANDARD QUALITY PLAN			QP No	SQP:HSFG:001		
		Quality Assurance		Item: HSFG Fasteners (Bolts, Nuts and washers)			Rev	1		
							Date	26.03.2024		
							Page	1 of 2		
SN	Component & Operation	Characteristics	Type of Check	Quantum of check	Reference Document	Acceptance Norm	Format of Record	Agency		Remarks
								M	B	
1.0	Raw material									
1.1	Raw material	Chemical & Mechanical	TC verification	100%	BHEL Specification (TDC & PO)		TC	V	V	
2.0	In Process									
2.1	Machining and Heat Treatment: NDE(UT/MPI)	Dimension, Temperature, Time, Medium, HT Chart, NDE	Report Review	100%	DO		R	P	V	NDE in Raw Material
3.0	Final Inspection (*)									
3.1	Visual & Dimension (*)	Visual, Dimension, thread & Marking (identification & colour coding)	Measurement/ Thread gauge	Sampling plan (*)	DO		R	P	W	(*) BHEL/BHEL TPIA will witness final inspection in supplier works or NABL approved Lab as per TDC to be followed. (#) For nut only hardness test and Proof load tet. For washers, hardness test only. Hardness after re-tempering in case of dispute
3.2	Mechanical testing (*,#)	Mechanical (Hardness, Strength under wedge load test, Minimum Tensile strength, Proof load test, Decarburization test, Hardness after re-tempering)	Testing	DO	DO		R	P	W	
3.3	Chemical (*)'	Chemical composition (refer note 2))	Testing	DO	DO		R	P	W	
3.4	NDE (*)	Surface quality	Testing (visual & MPI)	DO	DO		R	P	W	
3.5	Preservation	Preservation (rust preventive fluid)	Visual check		DO		TC	P	V	refer BHEL specification no PR:CHEM:09-04 (latest revision)

SANJU KOHLI
 Digitally signed by SANJU KOHLI
 Date: 2024.03.29 12:51:38 +05'30'
 Prepared By Sanju Kohli
 Manager, QM

SR KENNY
 Digitally signed by SR KENNY
 Date: 2024.03.29 15:27:35 +05'30'
 Reviewed and Approved By SR Kenny
 AGM, QM E

		BHEL: IVP Goindwal Quality Assurance		STANDARD QUALITY PLAN Item: HSFG Fasteners (Bolts, Nuts and washers)			QP No	SQP:HSFG:001		
							Rev	1		
							Date	26.03.2024		
							Page	2 of 2		
SN	Component & Operation	Characteristics	Type of Check	Quantum of check	Reference Document	Acceptance Norm	Format of Record	Agency		Remarks
3.5	Packing	Packing and Marking	Verification			DO	R	P	V	

Legends:
M-Manufacturer/Sub contractor, B-BHEL/Authorised inspection agency, V-Verification, W-Witness, P-Perform, R-Report, C-Customer, CHP- Customer Hold point, TC- Test Certificates

Note: 1. This QP shall be read along with relevant PO, TDC and applicable standards and drawings. Requirements shall be compiled.
2. Chemical check by spectro/wet method (minimum 1 number to be checked per inspection lot).

Record of Revision		
Rev	Date	Details of Revision
00	29.01.2021	1. Fresh Release/ Original issue
01	26.03.2024	1. Revised preservation method only

SANJU KOHLI
Digitally signed by SANJU KOHLI
Date: 2024.03.29 12:52:01 +05'30'
Prepared By
Sanju Kohli
Manager, QM

S R KENNY
Digitally signed by S R KENNY
Date: 2024.03.29 15:27:55 +05'30'
Reviewed and Approved By
SR Kenny
AGM, QM E



Bharat Heavy Electricals Ltd.,
Tiruchirappalli -14

Doc. No: PR: CHEM: 09 - 04
Rev: 03
Date: 01.04.2009
Page 1 of 3

PLANT LABORATORY

TECHNICAL SPECIFICATION FOR TEMPORARY RUST PREVENTIVE FLUID FOR BHEL USE TO IS 1153 (MODIFIED)

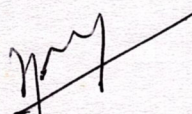
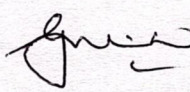
REV	DATE	PREPARED BY	REVIEWED AND APPROVED BY
03	01-04-2009	 L. Gragori DM/Plant Lab	 Dr. G. Ravichandran SDGM/Plant Lab

Controlled Copy No:	Issued to:



Bharat Heavy Electricals Ltd.,
Tiruchirappalli -14

Doc. No: PR: CHEM: 09 - 04

Rev: 03

Date: 01.04.2009

Page 2 of 3

Record of Revisions

Rev. No	Date	Details of Revision	Remarks
00	05.11.1992	NEW	----
01	04.04.1995	Sl.No. 1,3 & 5 modified	Quality improvement
02	20.05.2003	Sl.No. 8 Temperature Resistance Newly added	Based on Valves Requirement
03	01.04.2009	Editorial corrections made & new requirements added in Sl.No. 6, 12 & 16. Other Sl. No. Changed accordingly.	SSTP's additional requirements as given in TDC/CHEM/06 added.



REQUIREMENTS FOR TEMPORARY RUST PREVENTIVE FLUID

1	Specific Gravity at ambient temperature	0.85 - 0.95
2	Flash Point °C (min)	40
3	Drying time : Surface Dry (Hours, max)	½
	Tack free (Hours, max)	4
4	Dry film thickness (Microns) per coat-min	20
5	Ford cup Viscosity (No.4) seconds at ambient temperature	25 ± 5
6	Odour	No objectionable Odour
7	Film type Transparent/Translucent	Transparent
8	Application Method	Brush/Spray
9	% Non- Volatiles by mass	55 ± 5
10	Temperature Resistance of RPF film at 50 °C (for 6 hrs)	To pass test.
11	Corrosion Protection under conditions of condensation for 300 hours.	No sign of corrosion.
12	Liebermann –Storch test for the detection of natural resin & its derivatives	No development of pink colour – indicating absence of natural resin.
13	Salt spray test for 72 hours	No sign of corrosion.
14	Outdoor durability	The coating shall not crack or turn opaque when exposed to out door, unsheltered condition for 1 year.
15	Scratch Hardness test (Under load of 1000 g as per IS 101 (Latest)	To pass test
16	Compatibility with Alkyd /Lacquer based paints.	Compatible.
17	Keeping Property – Months (Shelf life) min.	12
18	General conformance to I.S Specification	IS 1153 (Latest)
19	Packing standard/markings	Supply in 200/20/10 Lt. Barrels as per PO indicating the following. Rust Preventive fluid for BHEL use only. Supplier's Name: Batch No: Date Quantity: Shelf Life: BHEL Specn.PR:CHEM:09-04 (latest)
20	Test certificate	The supplier shall furnish test certificate for the above requirements Sl.No.1 to 16 in duplicate.