



Bharat Heavy Electricals Limited
Industrial Valves Plant
Goindwal Sahib (Punjab)

Enquiry No.
2324-069E

Date:
13.12.2023

NOTICE INVITING TENDER (NIT)

Dear Sir / Madam,

BHEL Goindwal Sahib (Punjab) invites offers from interested bidders / suppliers for submission of their offer through e-procurement mode at <https://eprocurebhel.co.in/>. Offers in any other mode will not be accepted. In case of any difficulty faced while registering on BHEL's e-Procurement portal developed by NIC, queries may be addressed to 0120-4001002, 0120-4001005 and 0120-6277787; email: support-eproc@nic.in. These details are also available on 'Contact Us' page of the portal.

Tender enquiry no. & date	2324-069E dated 13.12.2023
Form of contract	Supply
Tender / Item description	Fasteners GVFST
Material standard / Drawings	As per attached TDC(s), Drawings and BPS.
Location(s) of Supply / Work	BHEL, IVP Goindwal, Punjab – 143422, India.
Earnest Money Deposit (EMD)	Not Applicable
Performance Security (PS)	Applicable (Refer Sr. no. 4 of GCC of tender terms)
Quotation parts	Two Part Bid
Tender download / Bid submission start date	13.12.2023 (12:00 Hrs. IST)
Tender download / Bid submission end date	23.12.2023 (12:00 Hrs. IST)
Tender / Bid opening date	23.12.2023 (15:30 Hrs. IST)
Validity of offer (In days)	75 days from techno commercial bid opening (Part I)
Quantity variation	+/- 10% of tender quantity
Delivery schedule	Within 90 days from the date of PO placement / LOI
Tender evaluation	Item Wise as detailed in Special Terms and Conditions
Reverse auction	Not Applicable
Make In India (MII) Purchase Preference	Applicable
MSE reserved	Items are reserved for MSE Manufactures
Contact person details	Sumeet Bansal, DGM 01859-224 628, sbansal@bhel.in Pranshu, Manager 01859-224 685, pranshu@bhel.in



SPECIAL TERMS AND CONDITIONS

Tender Enquiry No. 2324-069E Dated 13.12.2023 **Due date 23.12.2023**

Tender Description: Supply of Fasteners GVFST

S1. SCOPE OF SUPPLY

Material shall be supplied as per the applicable TDC/drawing as mentioned in the Table - 1. National & International material standards shall have to be arranged by bidders themselves.

Table 1 : List of Items along with Applicable TDC (Technical Delivery Condition) and Drawing / BPS / IS Standard Number.

Sr. No.	Material Code	Description	Qty (no.)	L1 Comparison will be done as (A)	Drawing No. with Rev. no. / BPS	Applicable TDC /Rev. no.	Applicable Standard	Stainless Steel Matl
1	931049650000	STUD-M8 x 55 - N204	50	SET (1 Set = 1 Stud + 2 Nuts)	3-V-N204-09338/00	TDC:5:164/10	--	
2	413020000800	THIN NUT-M 8 -CL5- IS1364P4	100		--	--	IS-1364(P-4)	
3	930596020000	STUD M8X30 - S833	500	SET (1 Set = 1 Stud + 2 Nuts)	3-V-S833-09338/00	TDC:5:164/10	--	
4	413190000800	NUT -M 8 - 2H	1,000		BPS 41319	TDC:5:164/10	--	
5	931071830000	STUD M8X80 - N210	100	SET (1 Set = 1 Stud + 2 Nuts)	3-V-N210-09338/00	TDC:5:164/10	--	
6	413200000800	NUT -M 8 - CL8- IS1364P3	200		--	--	IS-1364(P-3)	
7	964521930000	BOLT-M10x16 -B7-0002	300	Number	3-V-0002-20723/03	TDC:5:164/10	--	
8	930608660000	STUD-1076 M10X55	1,000	SET (1 Set = 1 Stud + 2 Nuts)	3-V-1076-03661/00	TDC:5:164/10	--	
9	413200001000	NUT -M10 - CL8- IS1364P3	2,000		--	--	IS-1364(P-3)	
10	413040001000	NUT -M10 - CL4- IS1363P3	100	Number	--	--	IS-1363(P-3)	
11	412371206000	BOLT-M12x60.-8.8- IS1364P1	700	SET (1 Set = 1 Bolt + Nut)	--	--	IS-1364(P-1)	
12	413200001200	NUT -M12 - CL8- IS1364P3	700		--	--	IS-1364(P-3)	
13	411011296000	DE STUD-M12x60 -6.6- IS1862-A-TL72-CAD	1,000	Number	--	--	IS-1862	



SPECIAL TERMS AND CONDITIONS

Tender Enquiry No. 2324-069E Dated 13.12.2023 **Due date 23.12.2023**

Tender Description: Supply of Fasteners GVFST

Sr. No.	Material Code	Description	Qty (no.)	L1 Comparison will be done as (A)	Drawing No. with Rev. no. / BPS	Applicable TDC /Rev. no.	Applicable Standard	Stainless Steel Matl
14	412371605000	BOLT-M16x50 -8.8-IS1364P1	1,000	Number	--	--	IS-1364(P-1)	
15	964522410000	BOLT-M16x50 -B7-0008	200	Number	3-V-0008-20723/03	TDC:5:164/10	--	
16	412371607000	BOLT-M16x70 -8.8-IS1364P1	300	Number	--	--	IS-1364(P-1)	
17	412371608000	BOLT-M16x80 -8.8-IS364P1	100	Number	--	--	IS-1364(P-1)	
18	411179624000	FT STUD-M16X240-B7-ZINC PHOSPATE COATING	100	SET (1 Set = 1 Stud + 2 Nuts)	--	TDC:5:164/10	--	
19	413020001600	THIN NUT-M16 -CL5-IS1364P4	200		--	--	IS-1364(P-4)	
20	931043380000	STUD M16X100-1479	100	SET (1 Set = 1 Stud + 2 Nuts)	2-V-1479-01897/00	TDC:5:164/10	A193-GR.B16	
21	413240001600	NUT -M16 -GR7	200		--	TDC:5:164/10	A194-GR7	
22	931017180000	STUD M16X50-S661	1,000	SET (1 Set = 1 Stud + 2 Nuts)	3-V-S661-09338/00	TDC:5:164/10	--	
23	413020001600 (Same as Sr. no. 19)	THIN NUT-M16 -CL5-IS1364P4	2,000		--	--	IS-1364(P-4)	
24	930595170000	STUD M16X55 -1135	1,500	SET (1 Set = 1 Stud + 2 Nuts)	3-V-1135-03661/01	TDC:5:164/10	--	
25	413190001600	NUT -M16 -2H	3,000		BPS 41319	TDC:5:164/10	--	
26	413040001600	NUT -M16 -CL4-IS1363P3	2,000	Number	--	--	IS-1363(P-3)	
27	964523140000	BOLT-M20x55 -B7-0009	300	Number	3-V-0009-20723/03	TDC:5:164/10	--	
28	412152006000	BOLT-M20x60 -6.8-IS1364P1	50	Number	--	--	IS-1364(P-I)	



SPECIAL TERMS AND CONDITIONS

Tender Enquiry No. 2324-069E Dated 13.12.2023 **Due date 23.12.2023**

Tender Description: Supply of Fasteners GVFST

Sr. No.	Material Code	Description	Qty (no.)	L1 Comparison will be done as (A)	Drawing No. with Rev. no. / BPS	Applicable TDC /Rev. no.	Applicable Standard	Stainless Steel Matl
29	964521960000	BOLT-M20x60 -B7-0005	200	Number	3-V-0005-20723/03	TDC:5:164/10	--	
30	964529810000	BOLT-M20x70 -B7-0006	400	Number	3-V-0006-20728/02	TDC:5:164/10	--	
31	412212008000	BOLT-M20x80 -4.6-IS1363P1	300	Number	--	--	IS-1363(P-1)	
32	411172012000	FT STUD-M20x120 -B7	1,000	SET (1 Set = 1 Stud + 2 Nuts)	--	TDC:5:164/10	--	
33	413190002000	NUT -M20 -2H	2,000		BPS 41319	TDC:5:164/10	--	
34	411172013000	FT STUD-M20x130 -B7	1,000	SET (1 Set = 1 Stud + 2 Nuts)	--	TDC:5:164/10	--	
35	413190002000 (Same as Sr. no. 33)	NUT -M20 -2H	2,000		BPS 41319	TDC:5:164/10	--	
36	411172014000	FT STUD-M20x140 -B7	2,500	SET (1 Set = 1 Stud + 2 Nuts)	BPS 41117	TDC:5:164/10	--	
37	413190002000 (Same as Sr. no. 35)	NUT -M20 -2H	5,000		BPS 41319	TDC:5:164/10	--	
38	964658310000	FT STUD-M20x2.5x130 -B8M	500	SET (1 Set = 1 Stud + 2 Nuts)	3-V-0003-25897/01	--	A193 B8M CL.2	Stainless Steel
39	964658390000	NUT -M20 -8M	1,000		4-V-0002-27368/00	--	A194-GR.8M	
40	931055020000	INDICATOR STUD M20X140 -K591	100	SET (1 Set = 1 Stud + 2 Nuts)	4-V-K591-06800/00	--	--	
41	413190002000 (Same as Sr. no. 37)	NUT -M20 -2H	200		BPS 41319	TDC:5:164/10	--	
42	414120002000	SPRING WASHER-M20 -IS6735-SQ	100	Number	--	--	IS-6735	
43	964650030000	BOLT-M24x75 -B7-0016	200	Number	3-V-0016-20728/00	TDC:5:164/10	--	
44	964531720000	BOLT-M24x85 -B7-0009	100	Number	3-V-0009-20728/03	TDC:5:164/10	--	



SPECIAL TERMS AND CONDITIONS

Tender Enquiry No. 2324-069E Dated 13.12.2023 **Due date 23.12.2023**

Tender Description: Supply of Fasteners GVFST

Sr. No.	Material Code	Description	Qty (no.)	L1 Comparison will be done as (A)	Drawing No. with Rev. no. / BPS	Applicable TDC /Rev. no.	Applicable Standard	Stainless Steel Matl
45	411172414000	FT STUD-M24x140 -B7	400	SET (1 Set = 1 Stud + 2 Nuts)	--	TDC:5:164/10	--	
46	413190002400	Hex Nut Gr B M24 T425 BPS 41319	800		BPS 41319	--	--	
47	964524410000	FT STUD-M30x3x185 - B7-0001	300	SET (1 Set = 1 Stud + 2 Nuts)	3-V-0001-20729/02	TDC:5:164/10	A193-GR.B7	
48	964606450000	NUT -M30x3 -2H-0008-H30	600		3-V-0008-20717/00	TDC:5:164/10	A194 GR.2H	
49	964527060000	FT STUD-M30x3x270 - B16-0031	100	SET (1 Set = 1 Stud + 2 Nuts)	3-V-0031-20729/02	TDC:5:164/10	A193-GR.B16	
50	964523100000	NUT -M30x3 -GR7-0010-H24	200		3-V-0010-20717/01	TDC:5:164/10	A194-GR.7	
51	964658940000	FT STUD-M33x3.5x220 -B8M	500	SET (1 Set = 1 Stud + 2 Nuts)	3-V-0008-25897/01	--	A193 B8M CL.2	Stainless Steel
52	964658970000	NUT - M33x3.5 - 8M	1,000		4-V-0006-27368/00	--	A194-GR.8M	
53	964655080000	FT STUD-M33x3.5x220 -B7-0025	200	SET (1 Set = 1 Stud + 2 Nuts)	3-V-0025-20729/00	TDC:5:164/10	A193-GR.B7	
54	964652740000	NUT - M33x3.5 - 2H-3234-H33	400		3-V-3234-20717/00	TDC:5:164/10	A194 GR.2H	
55	964653440000	FT STUD-M39x3x240 - B7-0020	100	SET (1 Set = 1 Stud + 2 Nuts)	3-V-0020-20729/00	TDC:5:164/10	A193-GR.B7	
56	413193003900	NUT -M39x3 -2H	200		--	TDC:5:164/10	--	
57	964562600000	BOLT- 1/2"x55 -B7-N073	700	SET (1 Set = 1 Bolt + Nut)	3-V-N073-06881/04	TDC:5:164/10	--	
58	964562790000	NUT -1/2" - 2H-N073	700		3-V-N073-06876/03	TDC:5:164/10	A194 GR.2H	
59	964656350000	FT STUD- 1/2"-13UNC-2A-80-B8M	1,000	SET (1 Set = 1 Stud + 2 Nuts)	3-V-0001-23248/01	--	A193 B8M CL.2	Stainless Steel
60	964656480000	HEX NUT- 1/2"-13UNC-	2,000		3-V-0001-23249/00	--	A194-GR.8M	



SPECIAL TERMS AND CONDITIONS

Tender Enquiry No. 2324-069E Dated 13.12.2023 **Due date 23.12.2023**

Tender Description: Supply of Fasteners GVFST

Sr. No.	Material Code	Description	Qty (no.)	L1 Comparison will be done as (A)	Drawing No. with Rev. no. / BPS	Applicable TDC /Rev. no.	Applicable Standard	Stainless Steel Matl
		2B-GR.8M						
61	964562680000	FT STUD-1/2"x80 -B7-N081	3,000	SET (1 Set = 1 Stud + 2 Nuts)	3-V-N081-06875/02	TDC:5:164/10	A193-GR.B7	
62	964562790000 (Same as Sr. no. 58)	NUT -1/2" - 2H-N073	6,000		3-V-N073-06876/03	TDC:5:164/10	A194 GR.2H	
63	964562610000	BOLT-5/8"x60 -B7-N033	700	SET (1 Set = 1 Bolt + Nut)	3-V-N033-06881/04	TDC:5:164/10	--	
64	964562800000	NUT -5/8" - 2H-N025	700		3-V-N025-06876/03	TDC:5:164/10	A194 GR.2H	
65	964656400000	FT STUD-3/4"-10UNC-2A-133-B8M	800	SET (1 Set = 1 Stud + 2 Nuts)	3-V-0006-23248/01	--	A193 B8M CL.2	Stainless Steel
66	964656500000	HEX NUT-3/4"-10UNC-2B-GR.8M	1,600		3-V-0003-23249/00	--	A194-GR.8M	
67	964564280000	FT STUD-3/4"x105 - B7-N204	200	SET (1 Set = 1 Stud + 2 Nuts)	3-V-N204-06875/02	--	A193-GR.B7	
68	964562810000	NUT -3/4" - 2H-N057	400		3-V-N057-06876/03	TDC:5:164/10	A194 GR.2H	
69	964656410000	FT STUD-7/8"-9UNC-2A-150-B8M	500	SET (1 Set = 1 Stud + 2 Nuts)	3-V-0007-23248/01	--	A193 B8M CL.2	Stainless Steel
70	964656510000	HEX NUT-7/8"-9UNC-2B-GR.8M	1,000		3-V-0004-23249/00	--	A194-GR.8M	
71	964564560000	FT STUD-7/8"x150 - B7-N212	1,000	SET (1 Set = 1 Stud + 2 Nuts)	3-V-N212-06875/02	TDC:5:164/10	A193-GR.B7	
72	964564310000	NUT -7/8" - 2H-N206	2,000		3-V-N206-06876/02	TDC:5:164/10	A194 GR.2H	
73	964656440000	FT STUD-1"-8UNC-2A-170-B8M	1,500	SET (1 Set = 1 Stud + 2 Nuts)	3-V-0010-23248/01	--	A193 B8M CL.2	Stainless Steel
74	964656520000	HEX NUT-1"-8UNC-2B-GR.8M	3,000		3-V-0005-23249/00	--	A194-GR.8M	
75	964564270000	FT STUD-1"x135 -B7-1387	1,000	SET (1 Set = 1 Stud + 2 Nuts)	3-V-1387-06875/02	TDC:5:164/10	A193-GR.B7	



SPECIAL TERMS AND CONDITIONS

Tender Enquiry No. 2324-069E Dated 13.12.2023 **Due date 23.12.2023**

Tender Description: Supply of Fasteners GVFST

Sr. No.	Material Code	Description	Qty (no.)	L1 Comparison will be done as (A)	Drawing No. with Rev. no. / BPS	Applicable TDC /Rev. no.	Applicable Standard	Stainless Steel Matl
76	964562820000	NUT -1" - 2H-N065	2,000		3-V-N065-06876/03	TDC:5:164/10	A194 GR.2H	
77	964562290000	FT STUD-1"x170 -B7-N224	2,000	SET (1 Set = 1 Stud + 2 Nuts)	3-V-N224-06875/02	TDC:5:164/10	A193-GR.B7	
78	964562820000 (Same as Sr. no. 76)	NUT -1" - 2H-N065	4,000		3-V-N065-06876/03	TDC:5:164/10	A194 GR.2H	
79	964656450000	FT STUD-1-1/8"-8UN-2A-180-B8M	200	SET (1 Set = 1 Stud + 2 Nuts)	3-V-0011-23248/01	--	A193 B8M CL.2	Stainless Steel
80	964656530000	HEX NUT-1.1/8"-8UN-2B-GR.8M	400		3-V-0006-23249/00	--	A194-GR.8M	
81	964659380000	FT STUD-1-1/8"-8UN-2A-220-B8M	300	SET (1 Set = 1 Stud + 2 Nuts)	3-V-F933-23248/00	--	A193 B8M CL.2	Stainless Steel
82	964656530000 (Same as Sr. no. 80)	HEX NUT-1.1/8"-8UN-2B-GR.8M	600		3-V-0006-23249/00	--	A194-GR.8M	
83	964562780000	FT STUD-1-1/8"x140 - B7-N106	400	SET (1 Set = 1 Stud + 2 Nuts)	3-V-N106-06875/02	TDC:5:164/10	A193-GR.B7	
84	964562830000	NUT -1-1/8" -2H-N105	800		3-V-N105-06876/03	TDC:5:164/10	A194 GR.2H	
85	964562770000	FT STUD-1-1/8"x180 - B7-N105	1,000	SET (1 Set = 1 Stud + 2 Nuts)	3-V-N105-06875/02	TDC:5:164/10	A193-GR.B7	
86	964562830000 (Same Sr. no. 84)	NUT -1-1/8" -2H-N105	2,000		3-V-N105-06876/03	TDC:5:164/10	A194 GR.2H	
87	964564360000	FT STUD-1-1/8"x205 - B7-C329	100	SET (1 Set = 1 Stud + 2 Nuts)	3-V-C329-17140/02	TDC:5:164/10	A193-GR.B7	
88	964562830000 (Same Sr. no. 86)	NUT -1-1/8" -2H-N105	200		3-V-N105-06876/03	TDC:5:164/10	A194 GR.2H	
89	964566810000	FT STUD-1-1/8"x220 - B7-F506	400	SET (1 Set = 1 Stud + 2 Nuts)	3-V-F506-06875/01	TDC:5:164/10	A193-GR.B7	
90	964562830000 (Same Sr. no. 88)	NUT -1-1/8" -2H-N105	800		3-V-N105-06876/03	TDC:5:164/10	A194 GR.2H	



SPECIAL TERMS AND CONDITIONS

Tender Enquiry No. 2324-069E Dated 13.12.2023 **Due date 23.12.2023**

Tender Description: Supply of Fasteners GVFST

Sr. No.	Material Code	Description	Qty (no.)	L1 Comparison will be done as (A)	Drawing No. with Rev. no. / BPS	Applicable TDC /Rev. no.	Applicable Standard	Stainless Steel Matl
91	964658300000	FT STUD-1 1/8"X140- B8M	100	SET (1 Set = 1 Stud + 2 Nuts)	3-V-0016- 23248/01	--	A193 B8M CL.2	Stainless Steel
92	964656530000 (Same as Sr. no. 82)	HEX NUT- 1.1/8"-8UN- 2B-GR.8M	200		3-V-0006- 23249/00	--	A194- GR.8M	
93	411172013900	FT STUD- M20x130 - B7-CAD	1,000	SET (1 Set = 1 Stud + 2 Nuts)	BPS 41117	--	--	
94	413010092000	NUT -M20 - CL6- IS1364P3- CAD	2,000		--	--	IS- 1364(P-3)	

Please take special attention of material type as stainless steel and class of fasteners and quote prices accordingly. For detail technical requirement please check applicable drawing/TDC/BPS/IS standard as mentioned in above list of items.

SPECIAL NOTES:

- The L1 evaluation will be done as per Set wise or number wise as per unit of L1 Comparison mentioned in column A of above table, so please take special attention while quoting prices in Part-II (BOQ).*
- Bidder has to submit Unit rate for Each item in the Price Bid/BOQ (Part-II), However evaluation of rates shall be done as per column A (L1 Comparison will be done as). Wherever of L1 Comparison is set, the bidder has to quote for both Bolt/Stud and Nut and also the material should be supply in assembled condition only. Wherever unit of L1 Comparison is number, the comparison will be done number-wise only.*
- Wherever the nuts are repeating that is item 19 and 23; 33, 35, 37 and 41; 58 and 62; 76 and 78; 80, 82 and 92; 84, 86, 88 and 90 of Table 1, minimum of the quoted rates will be considered for such nuts by the vendor.*
- Quality Assurance Plan Applicable:*
 - For stainless steel fasteners at 38, 39, 51, 52, 59, 60, 65, 66, 69, 70, 73, 74,79, 80, 81, 82, 91 and 92 is document number BHE:SQAP:SS:01 dt. 12.08.2021.*
 - For the remaining fasteners, document number BHE:QP:FAS:02 dt. 15.03.2019 / as per standard as applicable.*

ALL THESE ABOVE ITEMS ARE RESERVED FOR MSE MANUFACTURERS ONLY.

In case, no response is received from MSE bidder(s) for these items, then procurement will be made from Non-MSE bidder(s).

S2. PRE-QUALIFICATION CRITERIA (PQC)

Bidder has to submit following documents to fulfil PQC:



SPECIAL TERMS AND CONDITIONS

Tender Enquiry No. 2324-069E Dated 13.12.2023 **Due date 23.12.2023**

Tender Description: Supply of Fasteners GVFST

1. Supplier shall be manufacturer of Fasteners. Offers from Traders/Dealers/Stockists/agents will summarily be rejected. Submission of Certificate of Registration or UDYAM Certificate or Declaration from bidder for proof as a manufacturer is required to fulfil this criterion.
2. Bidder has to submit one or more purchase order/s of Fasteners from any customer with minimum cumulative value of Rs. 10,00,000 (Ten Lacs) along with the proof of execution like Invoice / Consignee Receipt Note / Completion Certificate, from any customer(s). PO date should be 01.12.2020 or afterwards till bid opening date". PO value mentioned above is net of taxes.

The details of the submitted POs along with its proof of execution must be filled as per attached Annexure - P. **Also, please note that the proof of execution like Invoice / Consignee Receipt Note / Completion Certificate must include the Purchase Order reference number, otherwise that PO will not be considered for the fulfilment of this tender term.**

Start-ups shall be exempted from this criterion of Purchase order and invoice submission without any relaxation in quality standards or technical parameters as per D.O. No. 5(4)/2016-BE-I dated 15.02.2017. For claiming Start-Up exemption, vendors have to submit DPIIT (Dept. of Promotion of Industry and Internal Trade)/DIPP (Department for Industrial Policy and Promotion) recognition certificates.

S3. PART-I: TECHNO-COMMERCIAL BID

This tender is through e-procurement mode for supply of "Fasteners GVSFT" as per specifications mentioned in below tender terms. Bidder has to submit their offer on BHEL e-Procurement portal at <https://eprocurebhel.co.in/>. **Offer in any other mode will not be accepted.** Please refer clause no. 1.2 of General Contract Conditions of MM Tenders (GCC), regarding instructions to bidder for submission of offer on BHEL e-procurement portal.

Tenders shall be submitted in Two parts on or before the due date and time indicated in the NIT

Part-I: Techno-Commercial Bid

Bid should contain all the documents/confirmations as per following details:

- a) Acceptance of Techno-Commercial terms and conditions shall be attached along with bid document (Duly filled Part-I Techno-Commercial Bid Questionnaire)

IF THE OFFER IS NOT ACCOMPANIED WITH ACCEPTANCE OF TERMS AND CONDITIONS, IT SHALL BE CONCLUDED THAT ALL THE TERMS AND CONDITIONS ARE ACCEPTABLE AND NO CLAIM WHATSOEVER SHALL BE ENTERTAINED LATER ON.

IF THERE IS ANY DEVIATION IN REFERENCE TO ANY OF THE TENDER TERM, KINDLY MENTION IN PART-I TECHNO-COMMERCIAL BID ONLY. DEVIATION SPECIFIED ELSEWHERE, WILL NOT BE CONSIDERED.

- b) Documents as per Pre-Qualification Criteria (PQC).

Part-II: Price Bid

Price Bid as per the attached format.



SPECIAL TERMS AND CONDITIONS

Tender Enquiry No. 2324-069E Dated 13.12.2023 **Due date 23.12.2023**

Tender Description: Supply of Fasteners GVFST

S4. REVERSE AUCTION

Reverse auction will not be conducted in this tender enquiry.

S5. DELIVERY SCHEDULE

Delivery shall be within 90 days from date of Purchase Order/ Letter of Intent.

S6. LOADING CRITERIA CUM COUNTER OFFER

No counter-offer will be given in this Tender Enquiry.

S7. INSPECTION

Bidders will submit TPI (Third party inspection) / BHEL Inspection report to BHEL IVP after inspection. Then based on Inspection report, BHEL will give dispatch clearance and then only the material shall be supplied to the respective consignee address.

These Special terms & conditions along with NIT and General Contract Conditions (GCC) collectively are the part of tender terms and conditions.



General Conditions of Contract (GCC) of MM Tenders

BHARAT HEAVY ELECTRICALS LIMITED

Industrial Valve Plant: 433, Industrial Complex,
Goindwal Sahib, Dist. Tarn Taran,
Punjab-143422 (INDIA)

TABLE OF CONTENTS

1. Instruction to Bidder	2
2. Scope of Supply	2
3. Price Basis.....	3
4. Performance Security (PS).....	3
5. Breach of contract, Remedies and Termination.....	4
6. Evaluation in Case of More Than One L-1 Bidder.....	4
7. Reverse Auction.....	4
8. Conflict of Interest among Bidders / Agents	5
9. Validity of Offers.....	5
10. Supplied Material Adjustment.....	5
11. Delivery Schedule.....	6
12. Liquidated Damaged (LD).....	6
13. Acceptance of Material Supplied.....	6
14. Payment Terms	7
15. Taxes & Duties	7
16. Liability Under Reverse Charge (RCM).....	8
17. Access to Manufacturing Premises.....	8
18. Inspection.....	8
19. Warrantee and Corresponding Repair / Replacement of Goods.....	9
20. LOI (Letter of Intent).....	10
21. Sub-Contract	10
22. Discrepancy in Words and Figures	10
23. Force Majeure	10
24. Non-Disclosure Agreement	11
25. Clarifications.....	11
26. Preferences for Micro and Small Enterprises (MSEs).....	11
27. Preference to Make in India.....	12
28. Restrictions Under Rule 144(XI) of The General Financial Rules (GFR), 2017	12
29. Resolution of Disputes.....	14
30. Fraud Prevention Policy.....	15
31. Preventive Checks to Eliminate Suspected Cartel Formation	15
32. Suspension of Business Dealings with Suppliers / Contractors	16
33. General.....	16
Annexure-X.....	19
Appendix-I of Annexure-X.....	25
Appendix-II of Annexure-X	26
Appendix-III of Annexure-X	27

Signature Not Verified

Signed By: AMAN SHARMA

Location: BHEL, Goindwal

Signing Date: 04.12.2023





General Conditions of Contract (GCC) of MM Tenders

BHARAT HEAVY ELECTRICALS LIMITED

Industrial Valve Plant: 433, Industrial Complex,
Goindwal Sahib, Dist. Tarn Taran,
Punjab-143422 (INDIA)

1. Instruction to Bidder

Quotations shall be submitted before due date and time. Late offers are liable to be rejected, so please ensure to submit bid well within due date and time. Techno-commercial part will be opened on due date.

Based on evaluation of techno-commercial offers, Price bids of bidders who qualify from techno-commercial evaluation shall be opened. BHEL may decide to open the Price bid same day at 1700 hrs. If not opened on the same day, all qualifying bidders shall be notified for date of opening of Price bids by email/fax/post/courier/E-procurement system generated email.

1.1 Instruction to Bidder (In case of Non-E-Procurement / Paper/ Manual/ Hard Copy based tenders)

Sealed Tenders can be dropped in the tender box labeled as 'Tender box for MM contracts.' This tender box is located at the entrance of Admin block BHEL Goindwal. Quotations can also be submitted through e-mail at tendermm_ivp@bhel.in. Offers received in time shall be considered only when offers are complete in all respects. In case of bulky tenders, please handover quotation to tender issuing authority [Contact: 01859 224 615 / 628]. Bid can be sent to following address:

**BHEL, Industrial Valve Plant,
#433, Industrial Complex,
Goindwal Sahib, Distt. Tarn Taran,
Punjab-143422.**

1.2 Instruction to bidder (In case of E-Procurement)

1. Interested bidders / suppliers shall submit their offer through e-procurement mode at <https://eprocurebhel.co.in/>.
2. **Offers in any other mode will not be accepted.**
3. Procedure for submission of tender is available in the "Bidder Manual Kit" at e-tender portal <https://eprocurebhel.co.in/>.
4. In case of any difficulty faced while registering on BHEL's e-Procurement portal developed by NIC, queries may be addressed to 0120-4001002, 0120-4001005 and 0120-6277787; email: support-eproc@nic.in. These details are also available on 'Contact Us' page of the portal.
5. Before uploading scanned documents if any, the bidders shall sign on all the statements, documents, certificates uploaded by him, owning responsibility for their correctness / authenticity.
6. **Disclaimer clause:** Neither the Organization (Bharat Heavy Electricals Ltd.) nor the service provider is responsible for any failure of submission of bids due to failure of internet or other connectivity problems or reasons thereof.

2. Scope of Supply

Material shall be supplied as per the applicable latest Technical Delivery Conditions (TDC)/ Material Standard requirements/BPS/Drawing and other requirement as given in the Tender Enquiry. National & International material Standards shall have to be arranged by vendors themselves. Latest applicable revisions of standards/procedures to be referred.

Signature Not Verified
Signed By: AMAN SHARMA
Location: BHEL Goindwal
Signing Date: 04.12.2023





General Conditions of Contract (GCC) of MM Tenders

BHARAT HEAVY ELECTRICALS LIMITED

Industrial Valve Plant: 433, Industrial Complex,
Goindwal Sahib, Dist. Tarn Taran,
Punjab-143422 (INDIA)

All required tests as called in referred material standard/BHEL/TDC/drawing etc. shall be carried out by vendor at no extra cost. Material Test Certificates (MTC), inspection reports and Compliance/Guarantee Certificate are to be provided along with the supplies.

3. Price Basis

1. Order of enquiry item sl. no. shall be maintained in the quotation.
2. The rates quoted shall be firm and fixed. No price variation is proposed and allowed.
3. Rates quoted should be FOR BHEL Goindwal basis. The offers quoted on other than FOR Goindwal basis are liable to be rejected.

In case bidder has quoted Ex-works prices, then he/she will be given an opportunity to accept price basis as FOR Goindwal either by accepting delivery as FOR Goindwal in same quoted price or by providing loading factor on his/her quoted ex-works prices to make them FOR prices.

Variation in GST or any other statutory levies during contractual delivery period shall be to BHEL's account.

4. Performance Security (PS)

Applicability:

- 1) Performance Security will not be applicable in which total PO value on vendor in one tender enquiry is less than or equal to Rupees one lakh.
- 2) **In case total PO value on vendor in one tender enquiry is greater than Rs. 1 Lakh:** Successful bidder (L1 or counter-offer accepted) has to submit Performance Security (PS) @5% of PO value within 21 days from the date of award of PO. PS shall be valid for a period of one year. This PS will be released to the vendor without interest after two months beyond the completion of all supplies under the PO.

Before the release of this PS, vendor has to submit another PS @1% of PO value or Rs. 3000.00 whichever is higher after two months beyond the completion of all supplies under the PO. This PS shall be valid for a period of 18 months. This additional PS will be released to the vendor without interest after expiry of validity upon fulfilment of contractual obligations as per terms of contract.

Vendor has to submit written request to BHEL for refund of PS well in advance before the due date.

In case of non-submission of PS for 5% of contract value, it will amount to breach of contract.

Mode of deposit:

Performance security may be furnished in the following forms:

- 1) Local cheques of Scheduled Banks (subject to realization)/ Pay Order/ Demand Draft/ Electronic Fund Transfer in favour of BHEL.
- 2) Bank Guarantee from Scheduled Banks / Public Financial Institutions as defined in the Companies Act. The Bank Guarantee format should have the approval of BHEL.
- 3) Fixed Deposit Receipt issued by Scheduled Banks / Public Financial Institutions as defined in the Companies Act (FDR should be in the name of the Contractor, a/c BHEL).

Signature Not Verified

Signed By: AMAN SHARMA

Location: BHEL Goindwal

Signing Date: 04.12.2023





General Conditions of Contract (GCC) of MM Tenders

BHARAT HEAVY ELECTRICALS LIMITED

Industrial Valve Plant: 433, Industrial Complex,
Goindwal Sahib, Dist. Tarn Taran,
Punjab-143422 (INDIA)

- 4) Securities available from Indian Post offices such as National Savings Certificates, Kisan Vikas Patras etc. (held in the name of Contractor furnishing the security and duly endorsed/hypothecated/ pledged, as applicable, in favour of BHEL).
- 5) Insurance Surety Bond.
- 6) By way of retention from dues available in the form of Bills payable to the supplier against same / other contracts in the same unit.

(Note: BHEL will not be liable or responsible in any manner for the collection of interest or renewal of the documents or in any other matter connected therewith).

Forfeiture of Performance Security:

The performance security will be forfeited and credited to BHEL's account in the event of a breach of contract by the supplier.

5. Breach of contract, Remedies and Termination

In case of breach of contract, wherever the value of security instruments like performance bank guarantee available with BHEL against the said contract is 10% of the contract value or more, such security instruments to the extent of 10% contract value will be encashed. In case the value of the security instruments available is less than 10% of the contract value, the balance amount be recovered in all or any of the following manners:

- from dues available in the form of Bills payable to defaulted supplier against the same contract.
- from the dues payable to defaulted supplier against other contracts in the same Region/Unit /any other region/unit.
- In-case recoveries are not possible with any of the above available options, Legal action shall be initiated for recovery against defaulted supplier.

Further, levy of liquidated damages, debarment, termination, de-scoping, short-closure, etc., shall be applied as per provisions of the contract.

6. Evaluation in Case of More Than One L-1 Bidder

In the course of evaluation, if more than one bidder happens to occupy L1 status, effective L1 will be decided by soliciting discounts from the respective L1 bidders.

In case more than one bidder happens to occupy the L1 status even after soliciting discounts, the L1 bidder shall be decided by a toss / draw of lots, in the presence of the respective L1 bidder(s) or their representative(s).

Ranking will be done accordingly. BHEL's decision in such situations shall be final and binding.

7. Reverse Auction

In case, it is declared in special terms & conditions of tender enquiry that RA is applicable for the NIT, then RA will be conducted as per following clause:

BHEL shall be resorting to Reverse Auction (RA) (Guidelines as available on <https://www.bhel.com/>) for this tender. RA shall be conducted among the techno-commercially qualified bidders as per RA guidelines.

Price bids of all techno-commercially qualified bidders shall be opened and same shall be considered

Signature Not Verified
Signed By: AMAN SHARMA
Location: BHEL, Goindwal
Signing Date: 04.12.2023





General Conditions of Contract (GCC) of MM Tenders

BHARAT HEAVY ELECTRICALS LIMITED

Industrial Valve Plant: 433, Industrial Complex,
Goindwal Sahib, Dist. Tarn Taran,
Punjab-143422 (INDIA)

for RA. In case any bidder(s) do(es) not participate in online Reverse Auction, their sealed envelope price bid along with applicable loading, if any, shall be considered for ranking.

8. Conflict of Interest among Bidders / Agents

A bidder shall not have conflict of interest with other bidders. Such conflict of interest can lead to anti-competitive practices to the detriment of Procuring Entity's interests. ***The bidder found to have a conflict of interest shall be disqualified.*** A bidder may be considered to have a conflict of interest with one or more parties in this bidding process, if:

- a) they have controlling partner (s) in common; **or**
- b) they receive or have received any direct or indirect subsidy/ financial stake from any of them; **or**
- c) they have the same legal representative/agent for purposes of this bid; **or**
- d) they have relationship with each other, directly or through common third parties, that puts them in a position to have access to information about or influence on the bid of another Bidder; **or**
- e) Bidder participates in more than one bid in this bidding process. Participation by a Bidder in more than one Bid will result in the disqualification of all bids in which the parties are involved. However, this does not limit the inclusion of the components/ sub-assembly/ Assemblies from one bidding manufacturer in more than one bid. **or**
- f) In cases of agents quoting in offshore procurements, on behalf of their principal manufacturers, one agent cannot represent two manufacturers or quote on their behalf in a particular tender enquiry. One manufacturer can also authorise only one agent/dealer. There can be only one bid from the following:
 1. The principal manufacturer directly or through one Indian agent on his behalf; and
 2. Indian/foreign agent on behalf of only one principal.**or**
- g) a Bidder or any of its affiliates participated as a consultant in the preparation of the design or technical specifications of the contract that is the subject of the Bid; **or**
- h) In case of a holding company having more than one independently manufacturing units, or more than one unit having common business ownership/management, only one unit should quote. Similar restrictions would apply to closely related sister companies. Bidders must proactively declare such sister/ common business/ management units in same/ similar line of business.

9. Validity of Offers

The offers shall be kept open for acceptance 'for number of days mentioned in special terms and conditions' from the date of opening of the tender. In case of tender extension, the bid validity shall be considered from the date of tender opening.

10. Supplied Material Adjustment

Item/s pending in previous PO has to be billed in previous PO only. Otherwise, BHEL will be free to adjust the supplies in previous PO. Any implication of tax will be on supplier's account. For this it is desirable that vendor should reconcile the pending PO statement every month/frequently with BHEL. Vendor can also view these details at Portal (<https://trichy.bhel.com/mm/index.jsp>).

Signature Not Verified
Signed By: AMAN SHARMA
Location: BHEL Goindwal
Signing Date: 04.12.2023





General Conditions of Contract (GCC) of MM Tenders

BHARAT HEAVY ELECTRICALS LIMITED

Industrial Valve Plant: 433, Industrial Complex,
Goindwal Sahib, Dist. Tarn Taran,
Punjab-143422 (INDIA)

11. Delivery Schedule

Supplies shall be affected and completed as per schedule mentioned in special terms and conditions. Commencement of delivery period shall be reckoned from the date of PO / LOI or any other agreed milestone.

12. Liquidated Damaged (LD)

- a) Time is the essence of the contract.
- b) The ordered items shall be delivered as per the delivery period mentioned in the Purchase Order.
- c) In case the supplier supplies the ordered items beyond the delivery period specified, Liquidated Damages -LD - as detailed below shall be levied from the supplier without prejudice to any other relief /compensation available to BHEL, Punjab under any other condition of the contract/applicable legal provisions.
- d) Failure to dispatch the materials in the time as per the delivery mentioned in our Purchase Order (PO) would make the supplier liable to an un-conditional LD at the rate of 0.5% of the undelivered order value per week of the delay or part thereof subject to a maximum of 10% of the undelivered order value.
- e) Any deviation from the above LD clause, loading will be applied to the extent to which it is not agreed by the bidder (at offered value).
- f) Indigenous: In case of Ex-works delivery terms, the document date (Invoice/Challan date) in Goods Receipt (GR) document shall be reckoned for LD deduction. In case of FOR Delivery terms, the posting date in GR document shall be reckoned for LD deduction.
- g) Import: For CFR terms, BL date will be considered for LD calculation.

BHEL reserves the right to receive or not receive the material after the due date of PO. Applicable GST shall also be recovered from suppliers/contractors on LD amount. For this Debit note will be issued by BHEL indicating the respective supply invoice number.

13. Acceptance of Material Supplied

1. The supply shall strictly as per the specifications in the tender /purchase order.
2. Delivery of the ordered items as per the delivery terms in the Purchase Order does not automatically constitute acceptance of the delivered items.
3. Acceptance of the materials supplied will be based on the inspection and certification documents by the supplier as stipulated in the Purchase order. However, BHEL reserves the right to test the material supplied, if required, at BHEL Lab or any other approved/accredited lab and the result will be binding on the supplier.
4. The acceptance or otherwise of the delivered items will be separately communicated to the supplier by BHEL through B2B portal within 15 days from the delivery of items or delivery of the required test certificates /other documents whichever is later.
5. In case of rejection of the delivered items, either part or full, the vendor shall replace the rejected items as per the specification in the Purchase order/tender at their cost within 30 days of communication of rejection to the supplier. The supplier shall be given maximum two opportunities to replace the rejected items.
6. After the clearance of the 1st lot, in case of rejection of the delivered items, either part or full, if the supplier fails to replace the rejected items within 30 days of communication of the rejection, the same shall be treated as failure to execute the contract and actions as per the Guidelines for

Signature Not Verified
Signed By: AMAN SHARMA
Location: BHEL, Goindwal
Signing Date: 04.12.2023





General Conditions of Contract (GCC) of MM Tenders

BHARAT HEAVY ELECTRICALS LIMITED

Industrial Valve Plant: 433, Industrial Complex,
Goindwal Sahib, Dist. Tarn Taran,
Punjab-143422 (INDIA)

Suspension of Business Dealings with Suppliers /Contractors available in the webpage: <https://www.bhel.com> would be taken against such supplier.

14. Payment Terms

1. Payments shall be made to the Seller within the mentioned days (as per below table) from the date of receipt and acceptance of material.

Type of Bidder	Payment Terms (Number of days)
Micro & Small Enterprises (MSEs)	45 days
Medium Enterprises	60 days
Non MSME	90 days

To be considered as Micro, Small or Medium enterprise, bidder must be manufacturer of offer product and relevant valid certificate as per latest MSME guidelines is to be submitted along with bid.

MSME bidders can avail benefits of payment through TReDS (Trade Receivable e Discounting System).

In case of any deviation from standard payment term mentioned above, BHEL shall load on the item price at 'Base rate of SBI (as applicable on the date of bid opening; Techno-commercial bid opening) + 6% for the period of relaxation sought by bidders.

2. Documents to be submitted (if applicable)
 - i) Tax invoice (Invoice shall be GST compliant and should contains all the required information such as GST No, HSN code etc.)
 - ii) Transporter copy along with material/consignment.
 - iii) Material Test Certificates (MTC) and
 - iv) Compliance Certificate.
3. GST registration number is to be submitted by qualified vendor as per GST law.
4. It is mandatory to mention proper material codes in the invoices and separate invoices to be raised for different POs.
5. **BHEL releases payment through EFT mode ONLY. Necessary details may please be submitted by filling required format before release of payment.**

15. Taxes & Duties

Payment of GST portion will be released to vendor only upon completion of statutory requirement and further subject to following:

- a) Vendor declaring such invoice in his GSTR-1 and
- b) Receipt of goods and Tax invoice by BHEL and
- c) Confirmation of payment of GST thereon by vendor on GSTN portal.
- d) Above is subject to receipt of goods/service and tax invoice thereof along with vendor declaring invoice in his return and paying GST within timeline prescribed for availing ITC by BHEL.

Following may please be noted for availing Input Tax Credit (ITC) by BHEL:

Signature Not Verified
Signed By: AMAN SHARMA
Location: BHEL, Goindwal
Signing Date: 04.12.2023





General Conditions of Contract (GCC) of MM Tenders

BHARAT HEAVY ELECTRICALS LIMITED

Industrial Valve Plant: 433, Industrial Complex,
Goindwal Sahib, Dist. Tarn Taran,
Punjab-143422 (INDIA)

1. Since ITC can be availed only when BHEL is in possession of GST Tax invoice and after receipt of goods. Thus, vendor to ensure timely dispatch of goods and Tax invoice. It may be noted that in case of any delay in receipt of Tax Invoice and/or receipt of goods, the ITC availment by BHEL will get delayed thus entailing additional cash outflow & may even get denied if ITC availment timelines are breached.
2. Further ITC can be availed only when vendor has declared such invoice in his outward supply Return GSTR-1 and after GST thereon has been paid by him at the time of filing of monthly Return.
3. If GST credit is delayed/denied to BHEL due to non/delayed receipt of goods and/or tax invoice or expiry of timeline prescribed in GST law for availing such ITC, or any other reasons not attributable to BHEL, GST amount shall be recoverable from vendor along with interest levied/leviable on BHEL.
4. Further, in case vendor delays declaring such invoice in his return and GST credit availed by BHEL is denied or reversed subsequently as per GST law, GST amount paid by BHEL towards such ITC reversal as per GST law shall be recoverable from vendor/contractor along with interest levied/leviable on BHEL.

16. Liability Under Reverse Charge (RCM)

Any GST liability arising on BHEL under Reverse Charge (RCM) before actual receipt of goods and/ or Invoice thereof would be subject to recovery of Interest leviable for the period between the date of such liability and actual date of eligibility of ITC based on receipt of goods, receipt of Invoices and other conditions specified in GST Law as applicable.

17. Access to Manufacturing Premises

While Purchase Orders placed on the vendor are under execution, authorized representatives of BHEL shall be allowed free access to the manufacturing facilities for the purpose of inspection or monitoring the progress of purchase orders. This access will also be extended to representatives of BHEL's customers accompanying the authorized representative/s of BHEL (which shall be intimated in advance), if our contractual requirements with our customers call for the same.

18. Inspection

1. The seller shall give adequate notice, of 1 week or as mutually agreed period, in writing to the Purchaser about the date and place at which the goods will be ready for inspection/ testing, as provided for in the contract.
2. Purchaser or his authorized representative shall be entitled to carry out inspection of material and workmanship/Surveillance Audit at Seller's premises or at his sub-contractor's premises at all reasonable times during execution of contract; Such inspection, examination and testing, if made, shall not absolve the Seller from his obligations under the contract. No additional charges shall be claimed for such inspections. Moreover, all required infrastructure (testing, tools etc) have to be arranged by supplier.
3. Any inspection carried out before supply by vendor/incoming stage at BHEL notwithstanding, if any defect/non-conformity is noted during processing, the same shall be attended/replaced by vendor at no extra cost.
4. BHEL representative from unit or CQ is authorized to carry out audits along with TPIA at vendor's works before clearing the items for dispatch.

Signature Not Verified

Signed By: AMAN SHARMA

Location: BHEL, Goindwal

Signing Date: 04.12.2023





General Conditions of Contract (GCC) of MM Tenders

BHARAT HEAVY ELECTRICALS LIMITED

Industrial Valve Plant: 433, Industrial Complex,
Goindwal Sahib, Dist. Tarn Taran,
Punjab-143422 (INDIA)

5. Necessary tooling including thread gauges etc. have to be arranged by vendor. Only in exceptional cases, based on BHEL discretions item/nature, BHEL may consider request to provide gauges if available with BHEL. But in no case this shall be linked with delivery of material.
6. In case of following points, visit charges to be paid to Third Party Inspection Agency (TPIA) shall be imposed as penalty on Supplier:
 - a) Nothing/NIL material is offered during Inspection (whilst physical visit of Inspection Engineer at Supplier's work) with respect to "Offered Quantity" mentioned in raised Inspection Call.
 - b) Lapses on the account of supplier has led to rejection of offered material (as per approved QAP/ Technical Specifications/ Other pertinent requirement), while carrying out Inspection.
 - c) Less Quantity/ Short Quantity is offered during Inspection (whilst physical visit of Inspection Engineer at Supplier's work) with respect to "Offered Quantity" mentioned in raised Inspection Call for any of the line(s) item, leading to re-visit of Inspection Engineer.

19. Warrantee and Corresponding Repair / Replacement of Goods

Goods shall comply with the specifications for material, workmanship and performance. Unless otherwise specified, vendor shall give a warrantee against design & manufacturing defects for a period of 18 months from the date of receipt. In case of non-acceptance of this term, bid shall be liable for rejection.

If the delivery is found non-compliant during the warranty period, leading to rejection, the Seller shall arrange free replacement / repair of goods, within one month from the date of intimation. Corresponding quantity shall be treated as unsupplied against respective purchase order till replacement is received at BHEL. In the event of the Seller's failure to comply, Purchaser may take action as appropriate, including repair / replenish rejected goods, at the cost of the seller as per contractual obligations.

All incidental charges like freight, insurance and customs duty in respect of return of defective items are to vendor's account only. BHEL will inform related invoice, quantity etc. to supplier. Supplier has to give advance intimation / plan (Transporter, Vehicle details) for the lifting of material. Further supplier has to provide requisite documents (such as Credit Note, e-Way Bill etc.) to lift the rejected material. Material should be lifted within one month from date of intimation. After one-month, BHEL will not be responsible for rejected material and BHEL shall have the right to dispose off such rejected material.

The defective parts and components shall be collected by your Indian agent or / authorized person, only after completing the replacement / repairs. If the supplier fails to replace / rectify the defective/ damaged items on free of cost within one month of reporting from our end, the same shall be treated as failure to execute the contract and actions as per the Guidelines for Suspension of Business Dealings with Suppliers /Contractors available in the webpage: <https://www.bhel.com> would be taken against such supplier without prejudice to the other remedies available to BHEL under the contract and law in this regard.





General Conditions of Contract (GCC) of MM Tenders

BHARAT HEAVY ELECTRICALS LIMITED

Industrial Valve Plant: 433, Industrial Complex,
Goindwal Sahib, Dist. Tarn Taran,
Punjab-143422 (INDIA)

20. LOI (Letter of Intent)

BHEL may issue LOI prior to the PO for any reason whatsoever. The LOI in such cases is to be treated as PO for all practical purposes and all the Terms & Conditions of the tender shall be applicable from the date of issue of LOI.

21. Sub-Contract

The purchase order or any part thereof shall not be sub-contracted, assigned or otherwise transferred without previously obtaining the BHEL's consent in writing.

22. Discrepancy in Words and Figures

1. If, in the price structure quoted for the required goods/ services/ works, there is discrepancy between the unit price and the total price (which is obtained by multiplying the unit price by the quantity}, the unit price shall prevail and the total price corrected accordingly, unless in the opinion of the purchaser there is an obvious misplacement of the decimal point in the unit price, in which case the total price as quoted shall govern and the unit price corrected accordingly.
2. If there is an error in a total corresponding to the addition or subtraction of subtotals, the subtotals shall prevail and the total shall be corrected; and
3. If there is a discrepancy between words and figures, the amount in words shall prevail, unless the amount expressed in words is related to an arithmetic error, in which case the amount in figures shall prevail subject of (a) and (b) above.
4. If there is such discrepancy in an offer, the same shall be conveyed to the bidder with target date upto which the bidder has to send his acceptance on the above lines and if the bidder does not agree to the decision of the purchaser, the bid is liable to be ignored.
5. Bids should be free from correction, overwriting, using corrective fluid, etc. Any interlineation, cutting, erasure or overwriting shall be valid only if they are attested under full signature(s) of person(s) signing the bid else shall be liable for rejection.
6. All overwriting/cutting, etc will be numbered by bid opening officials and announced during bid opening.

23. Force Majeure

1. Notwithstanding the provisions contained in other clauses, the supplier shall not be liable for imposition of any such sanction so long the delay and/or failure of the supplier in fulfilling its obligations under the contract is the result of an event of Force Majeure. For purposes of this clause, Force Majeure means an event beyond the control of the supplier and not involving the supplier's fault or negligence and which is not foreseeable and not brought about at the instance of the party claiming to be affected by such event and which has caused the non – performance or delay in performance. Such events may include, but are not restricted to, wars or revolutions, hostility, acts of public enemy, civil commotion, sabotage, fires, floods, explosions, epidemics, quarantine restrictions, strikes excluding by its employees, lockouts excluding by its management, freight embargoes and Acts of GOD.
2. If a Force Majeure situation arises, the supplier shall promptly notify the Purchaser/Consignee in writing of such conditions and the cause thereof within twenty-one days of occurrence of such event. Unless otherwise directed by the Purchaser/Consignee in writing, the supplier shall continue

Signature Not Verified

Signed By: AMAN SHARMA

Location: BHEL, Goindwal

Signing Date: 04.12.2023





General Conditions of Contract (GCC) of MM Tenders

BHARAT HEAVY ELECTRICALS LIMITED

Industrial Valve Plant: 433, Industrial Complex,
Goindwal Sahib, Dist. Tarn Taran,
Punjab-143422 (INDIA)

- to perform its obligations under the contract as far as reasonably practical, and shall seek all reasonable alternative means for performance not prevented by the Force Majeure event.
3. If the performance in whole or in part or any obligation under this contract is prevented or delayed by any reason of Force Majeure for a period exceeding sixty days, either party may at its option terminate the contract without any financial repercussion on either side.
 4. In case due to a Force Majeure event the Purchaser/Consignee is unable to fulfil its contractual commitment and responsibility, the Purchaser/Consignee will notify the supplier accordingly and subsequent actions taken on similar lines described in above sub-paragraphs.

24. Non-Disclosure Agreement

All Drawing and technical documents relating to the product or it's manufacture submitted by one party to the other, prior or subsequent to the formation of contract, shall remain property of the submitting party. Drawing, technical documents or other technical information received by one party, shall not without the consent of the other party, be used for any other purpose than that, for which they were provided. Such technical information shall not without the consent of the submitting party, otherwise be used or copied, reproduced, transmitted or communicated to a third party. Patterns supplied by BHEL will remain BHEL's property which shall be returned by the bidder on demand to BHEL. Bidder shall in no way share or use such intellectual property of BHEL to promote his own business with others. ***BHEL reserves the right to claim damages from the bidder, or take appropriate penal action as deemed fit against the bidder, for any infringement of the provisions contained herein.***

25. Clarifications

The correspondence exchanged against the tender from both tenderer and BHEL through email/e-procurement are considered as valid document legally though it is not signed. It is treated as valid confirmations made on behalf of the respective company and very much comes under the legal ambit of the business transaction and hence it is binding on both the parties to the business. Any transaction pertaining to the tender from both the parties of business done round the clock irrespective of the office or business hours of the companies, are valid legally and binding on both the parties. This applies to the extent only in such cases where deadline time for transaction is not specifically declared by either or both the parties to the business.

26. Preferences for Micro and Small Enterprises (MSEs)

Preferences as mentioned in “Public Procurement Policy for Micro and Small Enterprises (MSEs) Order, 2012” & “Public Procurement Policy for Micro and Small Enterprises (MSEs) Amendment Order, 2018”, or as per latest guidelines issued by government shall be given to Micro and Small enterprises.

Main points which are mentioned in the above orders are as follows:

- 25% Procurement of the tender value shall be made from MSE (Micro, Small Enterprises) firms.
- 25% of the 25% quantity (i.e. 6.25% of the tender quantity) offered to the MSE's shall be reserved for MSE's owned by SC/STs. Failure to participate by any MSE owned by SC/ST's; this 6.25% quantity shall be procured from other MSEs.

Signature Not Verified
Signed By: AMAN SHARMA
Location: BHEL, Goindwal
Signing Date: 04.12.2023





General Conditions of Contract (GCC) of MM Tenders

BHARAT HEAVY ELECTRICALS LIMITED

Industrial Valve Plant: 433, Industrial Complex,
Goindwal Sahib, Dist. Tarn Taran,
Punjab-143422 (INDIA)

- 3% from within the 25% quantity offered to the MSE's shall be reserved for women owned MSE's. Failure to participate by any MSE owned by women; this 3% quantity shall be procured from other MSEs.
- EMD shall be exempted for MSE's. All these benefits are subject to production of all statutory documents
- In tender, participating Micro and Small Enterprises quoting price within price band of L1+15 per cent shall also be allowed to supply a portion of requirement by bringing down their price to L1 price in a situation where L1 price is from someone other than a Micro and Small Enterprise and such Micro and Small Enterprise shall be allowed to supply up to 25 per cent of total tendered value. In case of more than one such Micro and Small Enterprise, the supply shall be shared proportionately (to tendered quantity).

MSE suppliers can avail the intended benefits only if they submit **Udyam Registration Certificate** along with the offer. No other document shall be considered for availing MSE benefits. Non-submission of such document will lead to consideration of their bid at par with other bidders. No benefit shall be applicable for this enquiry if any deficiency in the above required documents is not cleared before price bid opening. If the tender is to be submitted through e-procurement portal, then the above required document is to be uploaded on the portal.

Note: It may however be noted that MSE guidelines as on date (Date of Technical Bid Opening Part-1) shall prevail.

27. Preference to Make in India

This procurement shall be governed by notification no. P-45021/2/2017-PP (BE-II) dated 16.09.2020 of Government of India issued by DPIIT and subsequent circulars issued afterwards. Accordingly, the minimum local content, the margin of purchase preference and the procedure for purchase preference to make in India shall be adhered.

28. Restrictions Under Rule 144(XI) of The General Financial Rules (GFR), 2017

Restrictions on procurement from a bidder of a country which shares a land border with India

- a) Any bidder from a country which shares a land border with India will be eligible to bid in this tender, whether of goods or services (including consultancy services and non-consultancy services), only if the bidder is registered with the Competent Authority.
 - b) Further, any bidder (including an Indian bidder) who has a Specified Transfer of Technology (ToT) arrangement with an entity from a country which shares a land border with India will be eligible to bid in any procurement whether of goods or services (including consultancy services and non-consultancy services) only if the bidder is registered with the Competent Authority. *This clause shall be applicable only in the tenders which attract restrictions due to specified ToT.*
- II. "Bidder" (Seller / Service Provider) means any person or firm or company, including any member of a consortium or joint venture (that is an association of several persons, or firms or companies), every artificial juridical person not falling in any of the descriptions of bidders stated hereinbefore, including any agency branch or office controlled by such person, participating in a procurement process.

Signature Not Verified

Signed By: AMAN SHARMA

Location: BHEL, Goindwal

Signing Date: 04.12.2023





General Conditions of Contract (GCC) of MM Tenders

BHARAT HEAVY ELECTRICALS LIMITED

Industrial Valve Plant: 433, Industrial Complex,
Goindwal Sahib, Dist. Tarn Taran,
Punjab-143422 (INDIA)

- III. "Bidder (or entity) from a country which shares a land border with India" for the purpose of the Order means:
- An entity incorporated, established, or registered in such a country; or
 - A subsidiary of an entity incorporated, established, or registered in such a country; or
 - An entity substantially controlled through entities incorporated, established, or registered in such a country; or
 - An entity whose beneficial owner is situated in such a country; or
 - An Indian (or other) agent of such an entity; or
 - A natural person who is a citizen of such a country; or
 - A consortium or joint venture where any member of the consortium or joint venture falls under any of the above
- IV. The beneficial owner for the purpose of (iv) above will be as under
- In case of a company or Limited Liability Partnership, the beneficial owner is the natural person(s), who, whether acting alone or together, or through one or more juridical person, has a controlling ownership interest or who exercises control through other means.
Explanation—
 - "Controlling ownership interest" means ownership of or entitlement to more than twenty-five per cent. of shares or capital or profits of the company;
 - "Control" shall include the right to appoint majority of the directors or to control the management or policy decisions including by virtue of their shareholding or management rights or shareholders agreements or voting agreements;
 - In case of a partnership firm, the beneficial owner is the natural person(s) who, whether acting alone or together, or through one or more juridical person, has ownership of entitlement to more than fifteen percent of capital or profits of the partnership;
 - In case of an unincorporated association or body of individuals, the beneficial owner is the natural person(s), who, whether acting alone or together, or through one or more juridical person, has ownership of or entitlement to more than fifteen percent of the property or capital or profits of such association or body of individuals;
 - Where no natural person is identified under (1) or (2) or (3) above, the beneficial owner is the relevant natural person who holds the position of senior managing official;
 - In case of a trust, the identification of beneficial owner(s) shall include identification of the author of the trust, the trustee, the beneficiaries with fifteen percent or more interest in the trust and any other natural person exercising ultimate effective control over the trust through a chain of control or ownership.
- V. An Agent is a person employed to do any act for another, or to represent another in dealings with third person.
- VI. The registration shall be valid at the time of submission of bid and at the time of acceptance of bid.
- VII. If the bidder was validly registered at the time of acceptance / placement of order, registration shall not be a relevant consideration during contract execution.
- VIII. "Transfer of Technology" means dissemination and transfer of all forms of commercially usable knowledge such as transfer of know-how, skills, technical expertise, designs, processes and procedures, trade secrets, which enables the acquirer of such technology to perform activities using the transferred technology independently.

Signature Not Verified
Signed By: AMAN SHARMA
Location: BHEL, Goindwal
Signing Date: 04.12.2023





General Conditions of Contract (GCC) of MM Tenders

BHARAT HEAVY ELECTRICALS LIMITED

Industrial Valve Plant: 433, Industrial Complex,
Goindwal Sahib, Dist. Tarn Taran,
Punjab-143422 (INDIA)

Any false declaration and non-compliance of the above would be a ground for debarment and further legal action in accordance with law.

Bidder has to submit a certificate certifying following along with offer:

"I have read the clause regarding restrictions on procurement from a bidder of a country which shares a land border with India; I certify that this bidder is not from such a country or, if from such a country, has been registered with the Competent Authority. I hereby certify that this bidder fulfils all requirements in this regard and is eligible to be considered. [Where applicable, evidence of valid registration by the Competent Authority shall be Attached]."

29. Resolution of Disputes

The Parties agree that if at any time (whether before, during or after the arbitral or judicial proceedings), any Disputes (which term shall mean and include any dispute, difference, question or disagreement arising in connection with construction, meaning, operation, effect, interpretation or breach of the contract/tender which the Parties are unable to settle mutually), arise inter-se the Parties, the same may, be referred by either party to Conciliation to be conducted through Independent Experts Committee to be appointed by competent authority of BHEL from the BHEL Panel of Conciliators.

Notes:

1. No serving or a retired employee of BHEL/Administrative Ministry of BHEL shall be included in the BHEL Panel of Conciliators.
2. Any other person(s) can be appointed as Conciliator(s) who is/are mutually agreeable to both the parties from outside the BHEL Panel of Conciliators.

The proceedings of Conciliation shall broadly be governed by Part-III of the Arbitration and Conciliation Act 1996 or any statutory modification thereof and as provided in Annexure-X to this GCC.

The Annexure-X together with its appendices will be treated as if the same is part and parcel hereof and shall be as effectual as if set out herein in this GCC.

Except as provided elsewhere in this Contract, in case amicable settlement is not reached between the parties, in respect of any dispute or difference; arising out of the formation, breach, termination, validity or execution of the Contract; or, the respective rights and liabilities of the Parties; or, in relation to interpretation of any provision of the Contract; or, in any manner touching upon the Contract, then, either Party may, by a notice in writing to other Party, refer such dispute or difference to sole arbitration of an arbitrator appointed as per the Arbitration and Conciliation Act, 1996 (India) or statutory modification or re-enactment thereof and the rules made thereunder and for the time being in force.

The Arbitrator shall pass a reasoned award and the award of the Arbitrator shall be final and binding upon the parties.

This contract shall be governed, construed and interpreted in accordance with the laws of India.

Signature Not Verified
Signed By: AMAN SHARMA
Location: BHEL, Goindwal
Signing Date: 04.12.2023





General Conditions of Contract (GCC) of MM Tenders

BHARAT HEAVY ELECTRICALS LIMITED

Industrial Valve Plant: 433, Industrial Complex,
Goindwal Sahib, Dist. Tarn Taran,
Punjab-143422 (INDIA)

Subject as aforesaid, the provisions of Arbitration & Conciliation Act 1996 (India) or statutory modification or re-enactment thereof and the rules made thereunder and for the time being in force shall apply to the arbitration proceeding under this clause.

The seat of arbitration shall be Tarn Taran, Punjab, India.

The cost of arbitration shall be borne as per the award of the Arbitrator.

Subject to arbitration in terms of clause above, the Courts at Tarn Taran, Punjab, India shall have exclusive jurisdiction over any matter arising out of or in connection with this Contract.

Notwithstanding the existence or any dispute or difference and/or reference for the arbitration, the vendor/contractor shall proceed with and continue without hindrance the performance of its obligation under this Contract with due diligence and expedition in a professional manner except where the Contract has been terminated by either Party in terms of this Contract.

In Case of Contract with Public Sector Enterprise (PSE) or a Government Department, the following shall be applicable:

In the event of any dispute or difference relating to the interpretation and application of the provisions of commercial contract(s) between Central Public Sector Enterprises (CPSEs)/Port Trusts inter se and also between CPSEs and Government Departments/Organizations (Excluding disputes concerning Railways, Income Tax, Customs & Excise Departments, such dispute or difference shall be taken up by either party for its resolution through AMRCD as mentioned in DPE OM No.05/003/2019-FTS-10937 dated 14th December, 2022 and the decision of AMRCD on the said dispute will be binding on both the parties.”

Set off : BHEL shall have the right to recover any money which in the sole opinion of BHEL is due from the supplier from any money due to the supplier under this Contract or any other contract or from the Security Deposit/BG furnished by the supplier under this Contract or any other contract.

30. Fraud Prevention Policy

The Bidder along with its associate / collaborators / sub-contractors / sub-vendors / consultants / service providers shall strictly adhere to BHEL Fraud Prevention Policy displayed on BHEL website <https://www.bhel.com/> and shall immediately bring to the notice of BHEL management about any fraud or suspected fraud as soon as it comes to their notice.

31. Preventive Checks to Eliminate Suspected Cartel Formation

The Bidder declares that they will not enter into any illegal or undisclosed agreement or understanding, whether formal or informal with other Bidder(s). This applies in particular to prices, specifications, certifications, subsidiary contracts, submission or non-submission of bids or any other actions to restrict competitiveness or to introduce cartelization in the bidding process.





General Conditions of Contract (GCC) of MM Tenders

BHARAT HEAVY ELECTRICALS LIMITED

Industrial Valve Plant: 433, Industrial Complex,
Goindwal Sahib, Dist. Tarn Taran,
Punjab-143422 (INDIA)

In case, the Bidder is found having indulged in above activities, suitable action shall be taken by BHEL as per extant policies/ guidelines.

32. Suspension of Business Dealings with Suppliers / Contractors

The offers of the bidders who are under suspension as also the offers of the bidders, who engage the services of the firms debarred across BHEL, shall be rejected. The list of firms debarred across BHEL is available on BHEL web site <https://www.bhel.com/>.

INTEGRITY COMMITMENT, PERFORMANCE OF THE CONTRACT AND PUNITIVE ACTION THEREOF:

31.1. Commitment by BHEL:

BHEL commits to take all measures necessary to prevent corruption in connection with the tender process and execution of the contract. BHEL will during the tender process treat all Bidder(s) in a transparent and fair manner, and with equity.

31.2. Commitment by Bidder/ Supplier/ Contractor:

31.2.1. The bidder/ supplier/ contractor commits to take all measures to prevent corruption and will not directly or indirectly influence any decision or benefit which he is not legally entitled to nor will act or omit in any manner which tantamount to an offence punishable under any provision of the Indian Penal Code, 1860 or any other law in force in India.

31.2.2. The bidder/ supplier/ contractor will, when presenting his bid, disclose any and all payments he has made, and is committed to or intends to make to agents, brokers or any other intermediaries in connection with the award of the contract and shall adhere to relevant guidelines issued from time to time by Govt. of India/ BHEL.

31.2.3. The bidder/ supplier/ contractor will perform/ execute the contract as per the contract terms & conditions and will not default without any reasonable cause, which causes loss of business/ money/ reputation, to BHEL.

If any bidder/ supplier/ contractor during pre-tendering/ tendering/ post tendering/ award/ execution/ post-execution stage indulges in mal-practices, cheating, bribery, fraud or and other misconduct or formation of cartel so as to influence the bidding process or influence the price or acts or omits in any manner which tantamount to an offence punishable under any provision of the Indian Penal Code, 1860 or any other law in force in India, then, action may be taken against such bidder/ supplier/ contractor as per extant guidelines of the company available on <https://www.bhel.com/> and/or under applicable legal provisions

33. General

1. BHEL will not be bound by any power of attorney granted by the vendors or by changes in the composition of the firm made subsequent to the execution of the contract. They may, however,

Signature Not Verified

Signed By: AMAN SHARMA

Location: BHEL, Goindwal

Signing Date: 04.12.2023





General Conditions of Contract (GCC) of MM Tenders

BHARAT HEAVY ELECTRICALS LIMITED

Industrial Valve Plant: 433, Industrial Complex,
Goindwal Sahib, Dist. Tarn Taran,
Punjab-143422 (INDIA)

- recognize such power of attorney and changes after obtaining proper legal advice, the cost of which will be chargeable to the vendor concerned.
2. BHEL reserves the right to extend the due date of opening, which shall be informed. Validity of offer shall be deemed to be revised accordingly.
 3. BHEL reserves the right to accept or reject any part or whole of the tender of a bidder by assigning a valid reason thereof. BHEL reserves the right to cancel the tender without assigning any reason thereof and without any obligation before any commitment.
 4. Acceptance of all terms and conditions, in the form of signed copy of T&C or confirmation separately written, shall be submitted along with quotation. If nothing is mentioned, it shall be concluded that these terms and conditions are acceptable.
 5. BHEL may increase/decrease item/s based on BHEL requirement before price bid opening. Suitable price implication may be asked from suppliers.
 6. BHEL may drop item/items from tender at any stage of tender before placing PO. BHEL may also delete PO with consent with supplier within delivery date of PO.
 7. After releasing PO, it is assumed that supplier has accepted PO if we do not receive acknowledgement from supplier within 5 days of date of PO.
 8. In case of unscheduled holiday on opening day of tender, the next working day will be treated as scheduled prescribed day of opening of tender.
 9. On the due date of tender opening, only technical bids will be opened. The opened technical bids will be evaluated by us and clarifications required, if any, will be called for from the bidders on technical and commercial points. If no reply is received from the vendor for the clarification raised by BHEL within the final cut-off date, those vendors offer will be processed with the documents available / submitted against this tender. Offers not meeting the required specification and technical condition will be summarily rejected. The price bids of technically suitable bidders will be opened on a later date with prior intimation to techno-commercially suitable bidders.
 10. Ranking L-1, L-2 etc. shall be done for individual item for the techno-commercially acceptable offers on landed cost to BHEL, IVP Goindwal basis and BHEL reserves the right to place order for individual items with different vendors.
 11. BHEL reserves the right to negotiate with L1 vendor or re-float the tender for items where, L1 price is not the lowest acceptable price; BHEL reserves the right to increase or decrease the tender quantity.
 12. If supplier is mentioning delivery destination within state/ outside state depending upon his location of factory, Free on Road etc. these are assumed as on FOR Goindwal. If supplier is wishing to give delivery on Ex works basis, then he has to clearly mention about it.
 13. The bidder has to keep track of any changes by viewing the addendum(s) / Corrigendum(s) issued by the Purchaser on time-to- time basis in the E-Procurement platform. The Company calling for tenders shall not be responsible for any claims/problems arising out of this.
 14. Unregistered suppliers, who are techno-commercially qualified against the open tender, are requested to register with BHEL as permanent supplier by submitting the Supplier Registration Form (SRF) in online supplier registration portal (<https://supplier.bhel.in/>).
 15. The General Conditions of Contract and the Special Conditions in each enquiry and the resulting purchase order constitute the entire contract between the parties. In case of any discrepancy between the provisions of General Conditions of Contract and Special Conditions of the Tender,

Signature Not Verified

Signed By: AMAN SHARMA

Location: BHEL, Goindwal

Signing Date: 04.12.2023





General Conditions of Contract (GCC) of MM Tenders
BHARAT HEAVY ELECTRICALS LIMITED

Industrial Valve Plant: 433, Industrial Complex,
Goindwal Sahib, Dist. Tarn Taran,
Punjab-143422 (INDIA)

the provisions in Special Conditions of the Tender shall prevail and interpretation of BHEL of such condition/clause will be final and binding on both the parties ..





General Conditions of Contract (GCC) of MM Tenders

BHARAT HEAVY ELECTRICALS LIMITED

Industrial Valve Plant: 433, Industrial Complex,
Goindwal Sahib, Dist. Tarn Taran,
Punjab-143422 (INDIA)

Annexure-X

BRIEF PROCEDURE FOR CONDUCT OF CONCILIATION PROCEEDINGS

1. The proceedings of Conciliation shall broadly be governed by Part-III of the Arbitration and Conciliation Act 1996 or any statutory modification thereof and as provided herein:
2. The party desirous of resorting to Conciliation shall send an invitation/notice in writing to the other party to conciliate specifying all points of Disputes with details of the amount claimed. The party concerned shall not raise any new issue thereafter. Parties shall also not claim any interest on claims/counter-claims from the date of notice invoking Conciliation till the conclusion of the Conciliation proceedings.
3. The party receiving the invitation/notice for Conciliation shall within 30 days of receipt of the notice of Conciliation intimate its consent for Conciliation along with its counter-claims, if any.
4. The Conciliation in a matter involving claim or counter-claim (whichever is higher) up to Rs 5 crores shall be carried out by sole Conciliator nominated by BHEL while in a matter involving claim or counter-claim (whichever is higher) of more than Rs 5 crores Conciliation shall be carried out by 3 Conciliators nominated by BHEL.
5. The Parties shall be represented by only their duly authorized in-house executives/officers and neither Party shall be represented by a Lawyer.
6. The first meeting of the IEC shall be convened by the IEC by sending appropriate communication/notice to both the parties as soon as possible but not later than 30 days from the date of his/their appointment. The hearings in the Conciliation proceeding shall ordinarily be concluded within two (2) months and, in exceptional cases where parties have expressed willingness to settle the matter or there exists possibility of settlement in the matter, the proceedings may be extended by the IEC by a maximum of further 2 months with the consent of the Parties subject to cogent reasons being recorded in writing.
7. The IEC shall thereafter formulate recommendations for settlement of the Disputes supported by reasons at the earliest but in any case, within 15 days from the date of conclusion of the last hearing. The recommendations so formulated along with the reasons shall be furnished by the IEC to both the Parties at the earliest but in any case, within 1 month from the date of conclusion of the last hearing.
8. Response/modifications/suggestions of the Parties on the recommendations of the IEC are to be submitted to the IEC within time limit stipulated by the IEC but not more than 15 days from the date of receipt of the recommendations from the IEC.
9. In the event, upon consideration, further review of the recommendations is considered necessary, whether by BHEL or by the other Party, then, the matter can be remitted back to the IEC with

Signature Not Verified
Signed By: AMAN SHARMA
Location: BHEL, Goindwal
Signing Date: 04.12.2023





General Conditions of Contract (GCC) of MM Tenders

BHARAT HEAVY ELECTRICALS LIMITED

Industrial Valve Plant: 433, Industrial Complex,
Goindwal Sahib, Dist. Tarn Taran,
Punjab-143422 (INDIA)

- request to reconsider the same in light of the issues projected by either/both the Parties and to submit its recommendations thereon within the following 15 days from the date of remitting of the case by either of the Parties.
10. Upon the recommendations by the Parties, with or without modifications, as considered necessary, the IEC shall be called upon to draw up the Draft Settlement Agreement in terms of the recommendations.
 11. When a consensus can be arrived at between the parties only in regard to any one or some of the issues referred for Conciliation the draft Settlement Agreement shall be accordingly formulated in regard to the said Issue(s), and the said Settlement Agreement, if signed, by the parties, shall be valid only for the said issues. As regards the balance issues not settled, the parties may seek to resolve them further as per terms and conditions provided in the contract.
 12. In case no settlement can be reached between the parties, the IEC shall by a written declaration, pronounce that the Conciliation between the parties has failed and is accordingly terminated.
 13. Unless the Conciliation proceedings are terminated in terms of para 22 (b), (c) & (d) herein below, the IEC shall forward his/its recommendations as to possible terms of settlement within one (1) month from the date of last hearing. The date of first hearing of Conciliation shall be the starting date for calculating the period of 2 months.
 14. In case of 3 members IEC, 2 members of IEC present will constitute a valid quorum for IEC and meeting can take place to proceed in the matter after seeking consent from the member who is not available. If necessary, videoconferencing may be arranged for facilitating participation of the members. However, the IEC recommendations will be signed by all members. Where there is more than one (1) Conciliator, as a general rule they shall act jointly. In the event of differences between the Members of IEC, the decision/recommendations of the majority of the Members of IEC shall prevail and be construed as the recommendation of the IEC.
 15. The Draft Settlement Agreement prepared by the IEC in terms of the consensus arrived at during the Conciliation proceedings between the Parties shall be given by the IEC to both the parties for putting up for approval of their respective Competent Authority.
 16. Before submitting the draft settlement agreement to BHEL's Competent Authority viz. the Board Level Committee on Alternative Dispute Resolution (BLCADR) for approval, concurrence of the other party's Competent Authority to the draft settlement agreement shall be obtained by the other party and informed to BHEL within 15 days of receipt of the final draft settlement agreement by it. Upon approval by the Competent Authority, the Settlement Agreement would thereafter be signed by the authorized representatives of both the Parties and authenticated by the members of the IEC.
 17. In case the Draft Settlement Agreement is rejected by the Competent Authority of BHEL or the other Party, the Conciliation proceedings would stand terminated.

Signature Not Verified
Signed By: AMAN SHARMA
Location: BHEL, Goindwal
Signing Date: 04.12.2023





General Conditions of Contract (GCC) of MM Tenders

BHARAT HEAVY ELECTRICALS LIMITED

Industrial Valve Plant: 433, Industrial Complex,
Goindwal Sahib, Dist. Tarn Taran,
Punjab-143422 (INDIA)

18. A Settlement Agreement shall contain a statement to the effect that each of the person(s) signing thereto (i) is fully authorized by the respective Party(ies) he/she represents, (ii) has fully understood the contents of the same and (iii) is signing on the same out of complete freewill and consent, without any pressure, undue influence.
19. The Settlement Agreement shall thereafter have the same legal status and effect as an arbitration award on agreed terms on the substance of the dispute rendered by an arbitral tribunal passed under section 30 of the Arbitration and Conciliation Act, 1996.
20. Acceptance of the Draft Settlement Agreement/recommendations of the Conciliator and/or signing of the Settlement Agreement by BHEL shall however, be subject to withdrawal/closure of any arbitral and/or judicial proceedings initiated by the concerned Party in regard to such settled issues.
21. Unless otherwise provided for in the agreement, contract or the Memorandum of Understanding, as the case may be, in the event of likelihood of prolonged absence of the Conciliator or any member of IEC, for any reason/incapacity, the Competent Authority/Head of Unit/Division/Region/Business Group of BHEL may substitute the Conciliator or such member at any stage of the proceedings. Upon appointment of the substitute Conciliator(s), such reconstituted IEC may, with the consent of the Parties, proceed with further Conciliation into the matter either de-novo or from the stage already reached by the previous IEC before the substitution.
22. The proceedings of Conciliation under this Scheme may be terminated as follows:
- On the date of signing of the Settlement agreement by the Parties; or,
 - By a written declaration of the IEC, after consultation with the parties, to the effect that further efforts at conciliation are no longer justified, on the date of the declaration; or,
 - By a written declaration of the Parties addressed to the IEC to the effect that the Conciliation proceedings are terminated, on the date of the declaration; or,
 - By a written declaration of a Party to the other Party and the IEC, if appointed, to the effect that the Conciliation proceedings are terminated, on the date of the declaration.
 - On rejection of the Draft Settlement Agreement by the Competent Authority of BHEL or the other Party.





General Conditions of Contract (GCC) of MM Tenders

BHARAT HEAVY ELECTRICALS LIMITED

Industrial Valve Plant: 433, Industrial Complex,
Goindwal Sahib, Dist. Tarn Taran,
Punjab-143422 (INDIA)

23. The Conciliator(s) shall be entitled to following fees and facilities:

Sr. No.	Particulars	Amount
1	Sitting fees	Each Member shall be paid a Lump Sum fee of Rs 75,000/- for the whole case payable in terms of paragraph No. 27 herein below.
2	Towards drafting of settlement agreement	<p>In cases involving claim and/or counter-claim of up to Rs 5crores. Rs 50,000/- (Sole Conciliator)</p> <p>In cases involving claim and/or counter-claim of exceeding Rs 5 crores but less than Rs 10 crores. Rs. 75,000 (per Conciliator)</p> <p>In cases involving claim and/or counter-claim of more than Rs 10 crores. Rs 1,00,000/- (per Conciliator)</p> <p>Note: The aforesaid fees for the drafting of the Settlement Agreement shall be paid on Signing of the Settlement Agreement after approval of the Competent Authority or Rejection of the proposed Settlement Agreement by the Competent Authority of BHEL.</p>
3	Secretarial expenses	<p>Rs 10,000/- (one time) for the whole case for Conciliation by a Sole Member IEC.</p> <p>Where Conciliation is by multi member Conciliators –Rs 30,000/- (one time)- to be paid to the IEC</p>
4	Travel and transportation and stay at outstation	As per entitlement of the equivalent officer (pay scale wise) in BHEL.
	i Retired Senior Officials of other Public Sector Undertakings (pay scale wise equivalent to or more than E-8 level of BHEL)	
	Others	As per the extant entitlement of whole time Functional Directors in BHEL.

Signature Not Verified

Signed By: AMAN SHARMA

Location: BHEL, Goindwal

Signing Date: 04.12.2023





General Conditions of Contract (GCC) of MM Tenders BHARAT HEAVY ELECTRICALS LIMITED

Industrial Valve Plant: 433, Industrial Complex,
Goindwal Sahib, Dist. Tarn Taran,
Punjab-143422 (INDIA)

5	Venue for meeting	Unless otherwise agreed in the agreement, contract or the Memorandum of Understanding, as the case may be, the venue/seat of proceedings shall be the location of the concerned Unit / Division / Region / Business Group of BHEL. Without prejudice to the seat/venue of the Conciliation being at the location of concerned BHEL Unit / Division / Region / Business Group, the IEC after consulting the Parties may decide to hold the proceedings at any other place/venue to facilitate the proceedings. Unless, Parties agree to conduct Conciliation at BHEL premises, the venue is to be arranged by either Party alternately.
---	-------------------	--

24. The parties will bear their own costs including cost of presenting their cases/evidence/witness(es)/expert(s) on their behalf. The parties agree to rely upon documentary evidence in support of their claims and not to bring any oral evidence in IEC proceedings.

25. If any witness(es) or expert(s) is/are, with the consent of the parties, called upon to appear at the instance of the IEC in connection with the matter, then, the costs towards such witness(es)/expert(s) shall be determined by the IEC with the consent of the Parties and the cost so determined shall be borne equally by the Parties.

26. The other expenditures/costs in connection with the Conciliation proceedings as well as the IEC's fees and expenses shall be shared by the Parties equally.

27. Out of the lump sum fees of Rs 75,000/- for Sitting Fees, 50% shall be payable after the first meeting of the IEC and the remaining 50% of the Sitting Fees shall be payable only after termination of the conciliation proceedings in terms of para 22 hereinabove.

28. The travelling, transportation and stay at outstation shall be arranged by concerned Unit as per entitlements as per Serial No. 3 of the Table at para 23 above, and in case such arrangements are not made by the BHEL Unit, the same shall be reimbursed to the IEC on actuals limited to their entitlement as per Serial No. 4 of the Table at Para 23 above against supporting documents. The IEC Member(s) shall submit necessary invoice for claiming the fees/reimbursements.

29. The Parties shall keep confidential all matters relating to the conciliation proceedings. Confidentiality shall extend also to the settlement agreement, except where its disclosure is necessary for purposes of its implementation and enforcement or as required by or under a law or as per directions of a Court/Governmental authority/ regulatory body, as the case may be.

30. The Parties shall not rely upon or introduce as evidence in any further arbitral or judicial proceedings, whether or not such proceedings relate to the Disputes that is the subject of the Conciliation proceedings:

Signature Not Verified
Signed By: AMAN SHARMA
Location: BHEL, Goindwal
Signing Date: 04.12.2023





General Conditions of Contract (GCC) of MM Tenders

BHARAT HEAVY ELECTRICALS LIMITED

Industrial Valve Plant: 433, Industrial Complex,
Goindwal Sahib, Dist. Tarn Taran,
Punjab-143422 (INDIA)

- a. Views expressed or suggestions made by the other party in respect of a possible settlement of the Disputes;
- b. admissions made by the other party in the course of the Conciliator proceedings;
- c. proposals made by the Conciliator;
- d. The fact that the other Party had indicated his willingness to accept a proposal for settlement made by the Conciliator.

31. The Parties shall not present the Conciliator(s) as witness in any Alternative Dispute Resolution or Judicial proceedings in respect of a Disputes that is/was the subject of that particular Conciliation proceeding.

32. None of the Conciliators shall act as an arbitrator or as a representative or counsel of a Party in any arbitral or judicial proceeding in respect of a Disputes that is/was the subject of that particular Conciliation proceeding.

33. The Parties shall not initiate, during the Conciliation proceedings, any arbitral or judicial proceedings in respect of a Disputes that is the subject matter of the Conciliation proceedings except that a Party may initiate arbitral or judicial proceedings where, in his opinion, such proceedings are necessary for preserving his rights including for preventing expiry of period of limitation. Unless terminated as per the provisions of this Scheme, the Conciliation proceedings shall continue notwithstanding the commencement of the arbitral or judicial proceedings and the arbitral or judicial proceedings shall be primarily for the purpose of preserving rights including preventing expiry of period of limitation.

34. The official language of Conciliation proceedings under this Scheme shall be English unless the Parties agree to some other language.





General Conditions of Contract (GCC) of MM Tenders

BHARAT HEAVY ELECTRICALS LIMITED

Industrial Valve Plant: 433, Industrial Complex,
Goindwal Sahib, Dist. Tarn Taran,
Punjab-143422 (INDIA)

Appendix-I of Annexure-X

FORMAT FOR SEEKING CONSENT FOR REFERRING THE DISPUTES TO CONCILIATION THROUGH IEC

To,

M/s. (Stakeholder's name)

Sub: Resolution of the Disputes through conciliation by Independent Expert Committee (IEC).

Ref: Contract No/MoU/Agreement/LOI/LOA& date _____.

Sir,

With reference to above referred Contract/MoU/Agreement/LOI/LOA, you have raised certain Disputes/claims. Vide your letter dated____ you have requested BHEL to refer the Disputes/claims to IEC for Conciliation.

We are enclosing herewith Format (3) for giving consent and the terms and conditions of BHEL Conciliation Scheme, 2018 governing conciliation through IEC. You are requested to give your unconditional consent to the said terms and conditions of the Scheme by returning the same duly sealed and signed on each page. On receipt of your consent, matter will be put to the Competent Authority for consideration and decision.

Please note that BHEL has also certain claims against you (if applicable). BHEL reserves its right to agree or not to agree conciliation of the said disputes through BHEL and this letter is being issued without prejudice to BHEL's rights and contentions available under the contract and law.

Yours faithfully,

Representative of BHEL





General Conditions of Contract (GCC) of MM Tenders

BHARAT HEAVY ELECTRICALS LIMITED

Industrial Valve Plant: 433, Industrial Complex,
Goindwal Sahib, Dist. Tarn Taran,
Punjab-143422 (INDIA)

Appendix-II of Annexure-X

FORMAT FOR GIVING CONSENT BY CONTRACTOR/VENDOR/CUSTOMER/COLLABORATOR/CONSORTI UM PARTNERS FOR REFERRING THE DISPUTES TO CONCILIATION THROUGH IEC

To,

BHEL

.....

Sub: Resolution of Disputes through Conciliation by Independent Expert Committee (IEC).

Ref: Contract/MoU/Agreement/LOI/LOA No

& date ____

With reference to above referred contract, our following bills/invoices/claims submitted to BHEL are still unpaid giving rise to Disputes:

SL. no.	Claim Description	Bill submitted to BHEL (no. and date)	Amount of the bill/claim	Amount received from BHEL	Outstanding Amount

Accordingly, we request you to kindly refer the Disputes in respect of above claims to IEC for Conciliation.

We hereby agree and give our unconditional consent to the terms and conditions of BHEL Conciliation Scheme, 2018 governing conciliation through IEC. We have signed the same on each page and enclosed it for your consideration.

Yours faithfully,

(Signature with stamp)

**Authorized Representative of Contractor
Name, with designation Date**





General Conditions of Contract (GCC) of MM Tenders

BHARAT HEAVY ELECTRICALS LIMITED

Industrial Valve Plant: 433, Industrial Complex,
Goindwal Sahib, Dist. Tarn Taran,
Punjab-143422 (INDIA)

Appendix-III of Annexure-X

STATEMENT OF CLAIMS/COUNTER CLAIMS TO BE SUBMITTED TO THE IEC BY BOTH THE PARTIES

1. Chronology of the Disputes
2. Brief of the Contract/MoU/Agreement/LOI/LOA
3. Brief history of the Disputes:
4. Issues:
5. Details of Clam(s)/Counter Claim(s):

SI. No.	Description of claim(s)/Counter Claim	Amount (in INR) Or currency applicable in the contract	Relevant contract clause

6. Basis/Ground of claim(s)/counter claim(s) (along with relevant clause of contract)

Note– The Statement of Claims/Counter Claims may ideally be restricted to maximum limit of 20 pages. Relevant documents may be compiled and submitted along with the statement of Claims/Counter Claims. The statement of Claims/Counter Claims is to be submitted to all IEC members and to the other party by post as well as by email.



PART-I (TECHNO-COMMERCIAL BID)**(To be filled by bidder & submit with offer as pdf file only)****Tender Enquiry No. & Date****2324-069E Dt. 13.12.2023****Tender Description****Supply of Fasteners GVSFT**

Bidder must note following points:

1. This workbook is protected, except for cells where comments / confirmation is to be given by bidder.
2. Bidder is advised not to unprotect / tamper the sheet / alter the terms mentioned in the sheet.
3. Any alteration to terms mentioned by BHEL will be considered as tampering and bidder's offer shall be liable for rejection.
4. **Bidders are advised to only fill the unprotected cells (shaded cells) by dropdown or writing the comments as applicable as their confirmation. Bidders are advised to submit duly filled & signed 'PDF' file as techno-commercial (Part-I) bid'. Failure on the part of bidder in not returning this duly filled-up techno-commercial bid and / or submitting incomplete replies may lead to rejection of bidder's quotation.**
5. All the commercial terms and conditions shall be indicated by vendor in this format only and nowhere else in his quotation. However, in case the space for vendor's reply is not sufficient against a particular question, the vendor shall furnish same by way of separate annexure / sheet attached to this questionnaire, indicating cross-reference of respective clauses.

BIDDER'S DETAILS

Sr. No.	Elements	Remarks
1	Name of the Firm / Company	
2	Registered Address	
3	Quotation reference no. & date	
4	Contact person Details	
	Name / Designation	
	Contact Number	
	Email ID (can be more than one)	
6	Bidder Type (Indian / Foreign):	
7	Type of Ownership	Select from drop down list
8	Company's Nature of Business	Select from drop down list
9	Year of commencement of Business	
10	PAN No.	
11	GST No.	
12	Whether company is registered under MSME Act 2006 as Micro / Small / Medium Enterprise category. <i>(If yes, please attach valid certificate as per latest MSME guidelines)</i>	Yes (Valid Certificate attached) If yes, mention UDYAM registration number Here

TECHNICAL CONDITION DETAIL

Sr. No.	Elements	Response	Remarks
1	Technical : Supply of Fasteners GVSFT as per tender documents (if selected 'Accepted with deviation', please mention the deviation clearly)	Select from drop down list	

COMMERCIAL CONDITIONS & DETAILS

Sr. No.	Elements	Response	Remarks (if any)
1	Delivery term: FOR BHEL IVP Goindwal (refer tender terms & conditions)	Select from drop down list	
2	IGST supply (%)	Select from drop down list	
3	SGST supply (%)	Select from drop down list	
4	CGST supply (%)	Select from drop down list	
5	Validity: 75 days from techno commercial bid opening. (refer tender terms & conditions)	Select from drop down list	
6	Delivery period: Within 90 days from placement of PO / LOI. (refer tender terms & conditions)	Select from drop down list	
7	Self Declaration by Bidder : It is hereby declared that Bidder is 'manufacturer of Fasteners' (Refer special terms S2.1)	Select from drop down list	
8	Documents regarding Purchase Order/s of 'Fasteners' from any customer with minimum cumulative value of Rs. 10,00,000 along with the proof of execution (Refer special terms S2.2)	Select from drop down list	

PART-I (TECHNO-COMMERCIAL BID)

(To be filled by bidder & submit with offer as pdf file only)

Tender Enquiry No. & Date

2324-069E Dt. 13.12.2023

Tender Description

Supply of Fasteners GVSFT

Bidder must note following points:

1. This workbook is protected, except for cells where comments / confirmation is to be given by bidder.
2. Bidder is advised not to unprotect / tamper the sheet / alter the terms mentioned in the sheet.
3. Any alteration to terms mentioned by BHEL will be considered as tampering and bidder's offer shall be liable for rejection.
4. **Bidders are advised to only fill the unprotected cells (shaded cells) by dropdown or writing the comments as applicable as their confirmation. Bidders are advised to submit duly filled & signed 'PDF' file as techno-commercial (Part-I) bid'. Failure on the part of bidder in not returning this duly filled-up techno-commercial bid and / or submitting incomplete replies may lead to rejection of bidder's quotation.**
5. All the commercial terms and conditions shall be indicated by vendor in this format only and nowhere else in his quotation. However, in case the space for vendor's reply is not sufficient against a particular question, the vendor shall furnish same by way of separate annexure / sheet attached to this questionnaire, indicating cross-reference of respective clauses.

9	<p>Performance Security (PS) : For Total PO value placed through this tender is less than or equal to Rupees one lakh : Not Applicable. For Total PO value placed through this tender is greater than Rupees one lakh : PS @5% of PO value to be submitted within 21 days from the date of PO. (Refer Clause 4 of General Contract Conditions (GCC)).</p>	Select from drop down list									
10	Breach of contract, Remedies and Termination (Refer Clause 5 of General Contract Conditions (GCC)).	Select from drop down list									
11	Conflict of Interest among Bidders / Agents (Refer clause no. 8 of General Contract conditions (GCC))	Select from drop down list									
12	LD clause: Penalty for late delivery will be applicable @ 0.5% per week or part thereof subject to a maximum of 10.0 %. (Refer Clause 12 of General Contract Conditions (GCC)).	Select from drop down list									
13	Payment term: (Refer clause no. 14 of General Contract conditions (GCC))	Select from drop down list									
14	Warranty Period: Supplier shall give a warrantee for a period of 19 months from the date of receipt. In case of non-acceptance of this term bid will be rejected. (Refer clause no. 18 of GCC)	Select from drop down list									
15	Please attach valid MSE certificate latest MSME Guidelines (Refer clause no. 26 of GCC)	Select from drop down list									
16	<table border="1" style="width: 100%;"> <tr> <td style="width: 20%;">Make in India (MII) (Refer clause no. 27 of GCC)</td> <td>Local Content Declaration</td> <td style="text-align: center;">Select from drop down list</td> <td></td> </tr> <tr> <td></td> <td>Details of location at which local value addition will be made is as follows:</td> <td style="text-align: center;">Select from drop down list</td> <td></td> </tr> </table>	Make in India (MII) (Refer clause no. 27 of GCC)	Local Content Declaration	Select from drop down list			Details of location at which local value addition will be made is as follows:	Select from drop down list			
Make in India (MII) (Refer clause no. 27 of GCC)	Local Content Declaration	Select from drop down list									
	Details of location at which local value addition will be made is as follows:	Select from drop down list									
17	<table border="1" style="width: 100%;"> <tr> <td style="width: 20%;">Certificate regarding Restrictions Under Rule 144(XI) of The GFR, 2017 (Refer clause no. 28 of GCC)</td> <td>I have read the clause regarding restrictions on procurement from a bidder of a country which shares a land border with India; I certify that this bidder is not from such a country or, if from such a country, has been registered with the Competent Authority. I hereby certify that this bidder fulfils all requirements in this regard and is eligible to be considered.</td> <td style="text-align: center;">Select from drop down list</td> <td></td> </tr> </table>	Certificate regarding Restrictions Under Rule 144(XI) of The GFR, 2017 (Refer clause no. 28 of GCC)	I have read the clause regarding restrictions on procurement from a bidder of a country which shares a land border with India; I certify that this bidder is not from such a country or, if from such a country, has been registered with the Competent Authority. I hereby certify that this bidder fulfils all requirements in this regard and is eligible to be considered.	Select from drop down list							
Certificate regarding Restrictions Under Rule 144(XI) of The GFR, 2017 (Refer clause no. 28 of GCC)	I have read the clause regarding restrictions on procurement from a bidder of a country which shares a land border with India; I certify that this bidder is not from such a country or, if from such a country, has been registered with the Competent Authority. I hereby certify that this bidder fulfils all requirements in this regard and is eligible to be considered.	Select from drop down list									
18	Firm Price: The quoted / finalised rates shall be firm till execution of the supplies.	Select from drop down list									
19	I have thoroughly gone through the attached tender terms & conditions and understood the above techno-commercial requirements	Select from drop down list									
20	Rates quoted are net of taxes & FOR BHEL IVP Goindwal basis	Select from drop down list									
21	If there is any deviation in reference to any of the tender term, kindly mention it HERE only. Deviation specified elsewhere, will not be considered.	Select from drop down list									

Item detail

Item Sl. no.	Material Code	Description	Qty (in nos.)	Quoted / not quoted
1	931049650000	STUD-M8 x 55 - N204	50	Select from drop down list
2	413020000800	THIN NUT-M 8 -CL5-IS1364P4	100	Select from drop down list

PART-I (TECHNO-COMMERCIAL BID)

(To be filled by bidder & submit with offer as pdf file only)

Tender Enquiry No. & Date

2324-069E Dt. 13.12.2023

Tender Description

Supply of Fasteners GVSFT

Bidder must note following points:

1. This workbook is protected, except for cells where comments / confirmation is to be given by bidder.
2. Bidder is advised not to unprotect / tamper the sheet / alter the terms mentioned in the sheet.
3. Any alteration to terms mentioned by BHEL will be considered as tampering and bidder's offer shall be liable for rejection.
4. **Bidders are advised to only fill the unprotected cells (shaded cells) by dropdown or writing the comments as applicable as their confirmation. Bidders are advised to submit duly filled & signed 'PDF' file as techno-commercial (Part-I) bid'. Failure on the part of bidder in not returning this duly filled-up techno-commercial bid and / or submitting incomplete replies may lead to rejection of bidder's quotation.**
5. All the commercial terms and conditions shall be indicated by vendor in this format only and nowhere else in his quotation. However, in case the space for vendor's reply is not sufficient against a particular question, the vendor shall furnish same by way of separate annexure / sheet attached to this questionnaire, indicating cross-reference of respective clauses.

3	930596020000	STUD M8X30 -S833	500	Select from drop down list
4	413190000800	NUT -M 8 -2H	1,000	Select from drop down list
5	931071830000	STUD M8X80 -N210	100	Select from drop down list
6	413200000800	NUT -M 8 -CL8-IS1364P3	200	Select from drop down list
7	964521930000	BOLT-M10x16 -B7-0002	300	Select from drop down list
8	930608660000	STUD-1076 M10X55	1,000	Select from drop down list
9	413200001000	NUT -M10 -CL8-IS1364P3	2,000	Select from drop down list
10	413040001000	NUT -M10 -CL4-IS1363P3	100	Select from drop down list
11	412371206000	BOLT-M12x60.-8.8-IS1364P1	700	Select from drop down list
12	413200001200	NUT -M12 -CL8-IS1364P3	700	Select from drop down list
13	411011296000	DE STUD-M12x60 -6.6-IS1862-A-TL72-CAD	1,000	Select from drop down list
14	412371605000	BOLT-M16x50 -8.8-IS1364P1	1,000	Select from drop down list
15	964522410000	BOLT-M16x50 -B7-0008	200	Select from drop down list
16	412371607000	BOLT-M16x70 -8.8-IS1364P1	300	Select from drop down list
17	412371608000	BOLT-M16x80 -8.8-IS1364P1	100	Select from drop down list
18	411179624000	FT STUD-M16X240-B7-ZINC PHOSPATE COATING	100	Select from drop down list
19	413020001600	THIN NUT-M16 -CL5-IS1364P4	200	Select from drop down list
20	931043380000	STUD M16X100-1479	100	Select from drop down list
21	413240001600	NUT -M16 -GR7	200	Select from drop down list
22	931017180000	STUD M16X50-S661	1,000	Select from drop down list
23	413020001600 (Same as Sr. no. 19)	THIN NUT-M16 -CL5-IS1364P4	2,000	Select from drop down list
24	930595170000	STUD M16X55 -1135	1,500	Select from drop down list
25	413190001600	NUT -M16 -2H	3,000	Select from drop down list
26	413040001600	NUT -M16 -CL4-IS1363P3	2,000	Select from drop down list
27	964523140000	BOLT-M20x55 -B7-0009	300	Select from drop down list
28	412152006000	BOLT-M20x60 -6.8-IS1364P1	50	Select from drop down list

PART-I (TECHNO-COMMERCIAL BID)**(To be filled by bidder & submit with offer as pdf file only)****Tender Enquiry No. & Date****2324-069E Dt. 13.12.2023****Tender Description****Supply of Fasteners GVSFT**

Bidder must note following points:

1. This workbook is protected, except for cells where comments / confirmation is to be given by bidder.
2. Bidder is advised not to unprotect / tamper the sheet / alter the terms mentioned in the sheet.
3. Any alteration to terms mentioned by BHEL will be considered as tampering and bidder's offer shall be liable for rejection.
4. **Bidders are advised to only fill the unprotected cells (shaded cells) by dropdown or writing the comments as applicable as their confirmation. Bidders are advised to submit duly filled & signed 'PDF' file as techno-commercial (Part-I) bid'. Failure on the part of bidder in not returning this duly filled-up techno-commercial bid and / or submitting incomplete replies may lead to rejection of bidder's quotation.**
5. All the commercial terms and conditions shall be indicated by vendor in this format only and nowhere else in his quotation. However, in case the space for vendor's reply is not sufficient against a particular question, the vendor shall furnish same by way of separate annexure / sheet attached to this questionnaire, indicating cross-reference of respective clauses.

29	964521960000	BOLT-M20x60 -B7-0005	200	Select from drop down list
30	964529810000	BOLT-M20x70 -B7-0006	400	Select from drop down list
31	412212008000	BOLT-M20x80 -4.6-IS1363P1	300	Select from drop down list
32	411172012000	FT STUD-M20x120 -B7	1,000	Select from drop down list
33	413190002000	NUT -M20 -2H	2,000	Select from drop down list
34	411172013000	FT STUD-M20x130 -B7	1,000	Select from drop down list
35	413190002000 (Same as Sr. no. 33)	NUT -M20 -2H	2,000	Select from drop down list
36	411172014000	FT STUD-M20x140 -B7	2,500	Select from drop down list
37	413190002000 (Same as Sr. no. 35)	NUT -M20 -2H	5,000	Select from drop down list
38	964658310000	FT STUD-M20x2.5x130 -B8M	500	Select from drop down list
39	964658390000	NUT -M20 -8M	1,000	Select from drop down list
40	931055020000	INDICATOR STUD M20X140 -K591	100	Select from drop down list
41	413190002000 (Same as Sr. no. 37)	NUT -M20 -2H	200	Select from drop down list
42	414120002000	SPRING WASHER-M20 -IS6735-SQ	100	Select from drop down list
43	964650030000	BOLT-M24x75 -B7-0016	200	Select from drop down list
44	964531720000	BOLT-M24x85 -B7-0009	100	Select from drop down list
45	411172414000	FT STUD-M24x140 -B7	400	Select from drop down list
46	413190002400	Hex Nut Gr B M24 T425 BPS 41319	800	Select from drop down list
47	964524410000	FT STUD-M30x3x185 -B7-0001	300	Select from drop down list
48	964606450000	NUT -M30x3 -2H-0008-H30	600	Select from drop down list
49	964527060000	FT STUD-M30x3x270 -B16-0031	100	Select from drop down list
50	964523100000	NUT -M30x3 -GR7-0010-H24	200	Select from drop down list
51	964658940000	FT STUD-M33x3.5x220 -B8M	500	Select from drop down list
52	964658970000	NUT -M33x3.5 - 8M	1,000	Select from drop down list
53	964655080000	FT STUD-M33x3.5x220 -B7-0025	200	Select from drop down list
54	964652740000	NUT -M33x3.5 -2H-3234-H33	400	Select from drop down list

PART-I (TECHNO-COMMERCIAL BID)

(To be filled by bidder & submit with offer as pdf file only)

Tender Enquiry No. & Date

2324-069E Dt. 13.12.2023

Tender Description

Supply of Fasteners GVSFT

Bidder must note following points:

1. This workbook is protected, except for cells where comments / confirmation is to be given by bidder.
2. Bidder is advised not to unprotect / tamper the sheet / alter the terms mentioned in the sheet.
3. Any alteration to terms mentioned by BHEL will be considered as tampering and bidder's offer shall be liable for rejection.
4. **Bidders are advised to only fill the unprotected cells (shaded cells) by dropdown or writing the comments as applicable as their confirmation. Bidders are advised to submit duly filled & signed 'PDF' file as techno-commercial (Part-I) bid'. Failure on the part of bidder in not returning this duly filled-up techno-commercial bid and / or submitting incomplete replies may lead to rejection of bidder's quotation.**
5. All the commercial terms and conditions shall be indicated by vendor in this format only and nowhere else in his quotation. However, in case the space for vendor's reply is not sufficient against a particular question, the vendor shall furnish same by way of separate annexure / sheet attached to this questionnaire, indicating cross-reference of respective clauses.

55	964653440000	FT STUD-M39x3x240 -B7-0020	100	Select from drop down list
56	413193003900	NUT -M39x3 -2H	200	Select from drop down list
57	964562600000	BOLT-1/2"x55 -B7-N073	700	Select from drop down list
58	964562790000	NUT -1/2" -2H-N073	700	Select from drop down list
59	964656350000	FT STUD-1/2"-13UNC-2A-80-B8M	1,000	Select from drop down list
60	964656480000	HEX NUT-1/2"-13UNC-2B-GR.8M	2,000	Select from drop down list
61	964562680000	FT STUD-1/2"x80 -B7-N081	3,000	Select from drop down list
62	964562790000 (Same as Sr. no. 58)	NUT -1/2" -2H-N073	6,000	Select from drop down list
63	964562610000	BOLT-5/8"x60 -B7-N033	700	Select from drop down list
64	964562800000	NUT -5/8" -2H-N025	700	Select from drop down list
65	964656400000	FT STUD-3/4"-10UNC-2A-133-B8M	800	Select from drop down list
66	964656500000	HEX NUT-3/4"-10UNC-2B-GR.8M	1,600	Select from drop down list
67	964564280000	FT STUD-3/4"x105 -B7-N204	200	Select from drop down list
68	964562810000	NUT -3/4" -2H-N057	400	Select from drop down list
69	964656410000	FT STUD-7/8"-9UNC-2A-150-B8M	500	Select from drop down list
70	964656510000	HEX NUT-7/8"-9UNC-2B-GR.8M	1,000	Select from drop down list
71	964564560000	FT STUD-7/8"x150 -B7-N212	1,000	Select from drop down list
72	964564310000	NUT -7/8" -2H-N206	2,000	Select from drop down list
73	964656440000	FT STUD-1"-8UNC-2A-170-B8M	1,500	Select from drop down list
74	964656520000	HEX NUT-1"-8UNC-2B-GR.8M	3,000	Select from drop down list
75	964564270000	FT STUD-1"x135 -B7-1387	1,000	Select from drop down list
76	964562820000	NUT -1" -2H-N065	2,000	Select from drop down list
77	964562290000	FT STUD-1"x170 -B7-N224	2,000	Select from drop down list
78	964562820000 (Same as Sr. no. 76)	NUT -1" -2H-N065	4,000	Select from drop down list
79	964656450000	FT STUD-1-1/8"-8UN-2A-180-B8M	200	Select from drop down list
80	964656530000	HEX NUT-1.1/8"-8UN-2B-GR.8M	400	Select from drop down list

PART-I (TECHNO-COMMERCIAL BID)
(To be filled by bidder & submit with offer as pdf file only)

Tender Enquiry No. & Date

2324-069E Dt. 13.12.2023

Tender Description

Supply of Fasteners GVSFT

Bidder must note following points:

1. This workbook is protected, except for cells where comments / confirmation is to be given by bidder.
2. Bidder is advised not to unprotect / tamper the sheet / alter the terms mentioned in the sheet.
3. Any alteration to terms mentioned by BHEL will be considered as tampering and bidder's offer shall be liable for rejection.
4. Bidders are advised to only fill the unprotected cells (shaded cells) by dropdown or writing the comments as applicable as their confirmation. **Bidders are advised to submit duly filled & signed 'PDF' file as techno-commercial (Part-I) bid'. Failure on the part of bidder in not returning this duly filled-up techno-commercial bid and / or submitting incomplete replies may lead to rejection of bidder's quotation.**
5. All the commercial terms and conditions shall be indicated by vendor in this format only and nowhere else in his quotation. However, in case the space for vendor's reply is not sufficient against a particular question, the vendor shall furnish same by way of separate annexure / sheet attached to this questionnaire, indicating cross-reference of respective clauses.

81	964659380000	FT STUD-1-1/8"-8UN-2A-220-B8M	300	Select from drop down list
82	964656530000 (Same as Sr. no. 80)	HEX NUT-1.1/8"-8UN-2B-GR.8M	600	Select from drop down list
83	964562780000	FT STUD-1-1/8"x140 -B7-N106	400	Select from drop down list
84	964562830000	NUT -1-1/8" -2H-N105	800	Select from drop down list
85	964562770000	FT STUD-1-1/8"x180 -B7-N105	1,000	Select from drop down list
86	964562830000 (Same Sr. no. 84)	NUT -1-1/8" -2H-N105	2,000	Select from drop down list
87	964564360000	FT STUD-1-1/8"x205 -B7-C329	100	Select from drop down list
88	964562830000 (Same Sr. no. 86)	NUT -1-1/8" -2H-N105	200	Select from drop down list
89	964566810000	FT STUD-1-1/8"x220 -B7-F506	400	Select from drop down list
90	964562830000 (Same Sr. no. 88)	NUT -1-1/8" -2H-N105	800	Select from drop down list
91	964658300000	FT STUD-1 1/8"X140-B8M	100	Select from drop down list
92	964656530000 (Same as Sr. no. 82)	HEX NUT-1.1/8"-8UN-2B-GR.8M	200	Select from drop down list
93	411172013900	FT STUD-M20x130 -B7-CAD	1,000	Select from drop down list
94	413010092000	NUT -M20 -CL6-IS1364P3-CAD	2,000	Select from drop down list

We further, confirm that we have quoted the rates in the tender considering Inter-alia the

1. Tender Document(s)
2. Additional Document(s) (if any)
3. BOQ Document (Price Bid Format-Part-II)
4. Corrigendum (if any)
5. Pre Bid Meeting Minutes (if any)

We hereby certify that we have fully read and thoroughly understood the tender requirements and accept all terms and conditions of the tender including all corrigendum/addendum issued (if any). Our offer is in confirmation to all the terms and conditions of the tender including all corrigendum/addendum (if any) and minutes of the pre-bid meeting (if any). In the event our offer is found acceptable and Order is placed /Contract is awarded to us, the complete tender document shall be considered for constitution of Order / Contract Agreement.

Validate

Print

Help

Item Wise BoQ

Tender Inviting Authority: BHEL IVP Goindwal Sahib

Name of Work: Supply of Fasteners GVFS

Contract No: 2324-069E Dated 13.12.2023

Name of the Bidder/ Bidding Firm / Company :	
--	--

PRICE SCHEDULE

(This BOQ template must not be modified/replaced by the bidder and the same should be uploaded after filling the relevent columns, else the bidder is liable to be rejected for this tender. Bidders are allowed to enter the Bidder Name and Values only)

NUMBER #	TEXT #	TEXT #	NUMBER #	TEXT #	NUMBER #	NUMBER #
Sl. No.	Item Description	Item Code / Make	Quantity	Units	BASIC RATE In Figures To be entered by the Bidder in Rs. P	TOTAL AMOUNT excluding taxes in Rs. P
1	STUD-M8 x 55 - N204	931049650000	50	No.		0.00
2	THIN NUT-M 8 -CL5-IS1364P4	413020000800	100	No.		0.00
3	STUD M8X30 -S833	930596020000	500	No.		0.00
4	NUT -M 8 -2H	413190000800	1,000	No.		0.00
5	STUD M8X80 -N210	931071830000	100	No.		0.00
6	NUT -M 8 -CL8-IS1364P3	413200000800	200	No.		0.00
7	BOLT-M10x16 -B7-0002	964521930000	300	No.		0.00
8	STUD-1076 M10X55	930608660000	1,000	No.		0.00
9	NUT -M10 -CL8-IS1364P3	413200001000	2,000	No.		0.00
10	NUT -M10 -CL4-IS1363P3	413040001000	100	No.		0.00
11	BOLT-M12x60.-8.8-IS1364P1	412371206000	700	No.		0.00
12	NUT -M12 -CL8-IS1364P3	413200001200	700	No.		0.00
13	DE STUD-M12x60 -6.6-IS1862-A-TL72-CAD	411011296000	1,000	No.		0.00
14	BOLT-M16x50 -8.8-IS1364P1	412371605000	1,000	No.		0.00
15	BOLT-M16x50 -B7-0008	964522410000	200	No.		0.00
16	BOLT-M16x70 -8.8-IS1364P1	412371607000	300	No.		0.00
17	BOLT-M16x80 -8.8-IS364P1	412371608000	100	No.		0.00
18	FT STUD-M16X240-B7-ZINC PHOSPATE COATING	411179624000	100	No.		0.00
19	THIN NUT-M16 -CL5-IS1364P4	413020001600	200	No.		0.00
20	STUD M16X100-1479	931043380000	100	No.		0.00
21	NUT -M16 -GR7	413240001600	200	No.		0.00
22	STUD M16X50-S661	931017180000	1,000	No.		0.00
23	THIN NUT-M16 -CL5-IS1364P4	413020001600 (Same as Sr. no. 19)	2,000	No.		0.00
24	STUD M16X55 -1135	930595170000	1,500	No.		0.00
25	NUT -M16 -2H	413190001600	3,000	No.		0.00
26	NUT -M16 -CL4-IS1363P3	413040001600	2,000	No.		0.00
27	BOLT-M20x55 -B7-0009	964523140000	300	No.		0.00
28	BOLT-M20x60 -6.8-IS1364P1	412152006000	50	No.		0.00
29	BOLT-M20x60 -B7-0005	964521960000	200	No.		0.00
30	BOLT-M20x70 -B7-0006	964529810000	400	No.		0.00
31	BOLT-M20x80 -4.6-IS1363P1	412212008000	300	No.		0.00
32	FT STUD-M20x120 -B7	411172012000	1,000	No.		0.00
33	NUT -M20 -2H	413190002000	2,000	No.		0.00
34	FT STUD-M20x130 -B7	411172013000	1,000	No.		0.00
35	NUT -M20 -2H	413190002000 (Same as Sr. no. 33)	2,000	No.		0.00
36	FT STUD-M20x140 -B7	411172014000	2,500	No.		0.00
37	NUT -M20 -2H	413190002000 (Same as Sr. no. 35)	5,000	No.		0.00
38	FT STUD-M20x2.5x130 -B8M	964658310000	500	No.		0.00
39	NUT -M20 -8M	964658390000	1,000	No.		0.00

40	INDICATOR STUD M20X140 -K591	93105502000	100	No.		0.00
41	NUT -M20 -2H	413190002000 (Same as Sr. no. 37)	200	No.		0.00
42	SPRING WASHER-M20 -IS6735-SQ	414120002000	100	No.		0.00
43	BOLT-M24x75 -B7-0016	964650030000	200	No.		0.00
44	BOLT-M24x85 -B7-0009	964531720000	100	No.		0.00
45	FT STUD-M24x140 -B7	411172414000	400	No.		0.00
46	Hex Nut Gr B M24 T425 BPS 41319	413190002400	800	No.		0.00
47	FT STUD-M30x3x185 -B7-0001	964524410000	300	No.		0.00
48	NUT -M30x3 -2H-0008-H30	964606450000	600	No.		0.00
49	FT STUD-M30x3x270 -B16-0031	964527060000	100	No.		0.00
50	NUT -M30x3 -GR7-0010-H24	964523100000	200	No.		0.00
51	FT STUD-M33x3.5x220 -B8M	964658940000	500	No.		0.00
52	NUT -M33x3.5 - 8M	964658970000	1,000	No.		0.00
53	FT STUD-M33x3.5x220 -B7-0025	964655080000	200	No.		0.00
54	NUT -M33x3.5 -2H-3234-H33	964652740000	400	No.		0.00
55	FT STUD-M39x3x240 -B7-0020	964653440000	100	No.		0.00
56	NUT -M39x3 -2H	413193003900	200	No.		0.00
57	BOLT-1/2"x55 -B7-N073	964562600000	700	No.		0.00
58	NUT -1/2" -2H-N073	964562790000	700	No.		0.00
59	FT STUD-1/2"-13UNC-2A-80-B8M	964656350000	1,000	No.		0.00
60	HEX NUT-1/2"-13UNC-2B-GR.8M	964656480000	2,000	No.		0.00
61	FT STUD-1/2"x80 -B7-N081	964562680000	3,000	No.		0.00
62	NUT -1/2" -2H-N073	964562790000 (Same as Sr. no. 58)	6,000	No.		0.00
63	BOLT-5/8"x60 -B7-N033	964562610000	700	No.		0.00
64	NUT -5/8" -2H-N025	964562800000	700	No.		0.00
65	FT STUD-3/4"-10UNC-2A-133-B8M	964656400000	800	No.		0.00
66	HEX NUT-3/4"-10UNC-2B-GR.8M	964656500000	1,600	No.		0.00
67	FT STUD-3/4"x105 -B7-N204	964564280000	200	No.		0.00
68	NUT -3/4" -2H-N057	964562810000	400	No.		0.00
69	FT STUD-7/8"-9UNC-2A-150-B8M	964656410000	500	No.		0.00
70	HEX NUT-7/8"-9UNC-2B-GR.8M	964656510000	1,000	No.		0.00
71	FT STUD-7/8"x150 -B7-N212	964564560000	1,000	No.		0.00
72	NUT -7/8" -2H-N206	964564310000	2,000	No.		0.00
73	FT STUD-1"-8UNC-2A-170-B8M	964656440000	1,500	No.		0.00
74	HEX NUT-1"-8UNC-2B-GR.8M	964656520000	3,000	No.		0.00
75	FT STUD-1"x135 -B7-1387	964564270000	1,000	No.		0.00
76	NUT -1" -2H-N065	964562820000	2,000	No.		0.00
77	FT STUD-1"x170 -B7-N224	964562290000	2,000	No.		0.00
78	NUT -1" -2H-N065	964562820000 (Same as Sr. no. 76)	4,000	No.		0.00
79	FT STUD-1-1/8"-8UN-2A-180-B8M	964656450000	200	No.		0.00
80	HEX NUT-1.1/8"-8UN-2B-GR.8M	964656530000	400	No.		0.00
81	FT STUD-1-1/8"-8UN-2A-220-B8M	964659380000	300	No.		0.00
82	HEX NUT-1.1/8"-8UN-2B-GR.8M	964656530000 (Same as Sr. no. 80)	600	No.		0.00
83	FT STUD-1-1/8"x140 -B7-N106	964562780000	400	No.		0.00
84	NUT -1-1/8" -2H-N105	964562830000	800	No.		0.00
85	FT STUD-1-1/8"x180 -B7-N105	964562770000	1,000	No.		0.00
86	NUT -1-1/8" -2H-N105	964562830000 (Same Sr. no. 84)	2,000	No.		0.00
87	FT STUD-1-1/8"x205 -B7-C329	964564360000	100	No.		0.00
88	NUT -1-1/8" -2H-N105	964562830000 (Same Sr. no. 86)	200	No.		0.00
89	FT STUD-1-1/8"x220 -B7-F506	964566810000	400	No.		0.00
90	NUT -1-1/8" -2H-N105	964562830000 (Same Sr. no. 88)	800	No.		0.00
91	FT STUD-1 1/8"X140-B8M	964658300000	100	No.		0.00
92	HEX NUT-1.1/8"-8UN-2B-GR.8M	964656530000 (Same as Sr. no. 82)	200	No.		0.00
93	FT STUD-M20x130 -B7-CAD	411172013900	1,000	No.		0.00
94	NUT -M20 -CL6-IS1364P3-CAD	413010092000	2,000	No.		0.00
Total in Figures						0.000

SL.No	DRG.No.	RAW MATERIAL				DIMENSIONS				FINISH WT. (KP)	APPLICABLE TYPE Nos.	SL.No	
		SPECIFICATION	SIZE	CODE No.	WT. (KP)	L	Md- g	c/45					
1	3-V-S661-09338	ASTM-A-193 87	BAR. ϕ 20X55	15039084	0.16	50	M16	2		0.09	S661 S665, S666, S964, S998	1	
2	3-V-S833-09338	ASTM-A193 87	BAR ϕ 12X35	15039091	0.03	30	M8	1		0.01	S833, S834, S835, S836, S837, S838, S839, S840, S841, S842, S843, S844, S845, S846, S847, S848, S849, S850, S851, S852, S853, S854, S865, S866, S867, S868, S869, S860, S861, S862, S863, S864, S870, S882, S883, S884, S885	2	
3	3-V-S858-09338	ASTM-A193 87	BAR ϕ 12X35	15039091	0.03	40	M8	1		0.008	S858, S859	3	
4	3-V-N204-09338 93104965 0000	ASTM A193 87	BAR ϕ 12X60	15039091	0.53	55	M8	1		0.02	N204	4	
5	3-V-N210-09338 93107183 0000		ϕ 10X90	-	-	0.80	80	M8	1		0.05	2.3.4" - 150c & 300c GV	5
6	3-V-N645-09338 93108303 0000		ϕ 25X120	-	-	0.462	110	M20	2		0.27	N645	

125/32

MICROFILMED ON 21.1.84
ROLL 00502 FRAME 129

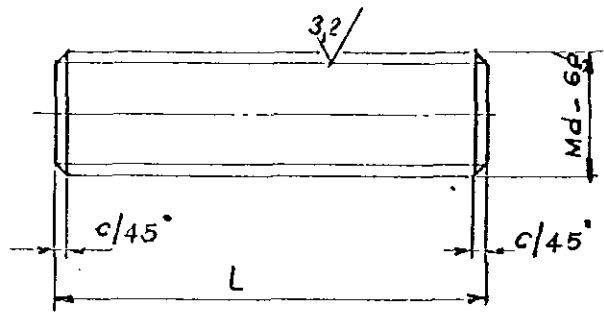

REV DATE	06	11-09-97	ALTD; N.D. PAL	MD
REV DATE	05	18-9-96	ALTD T.C. CHD	MD
SL NO. 6 IS INCLUDED				
SL NO. 05 INCLUDED.				

ASTM-A 193-87	Q & T	10	- CERTIFY
MATERIAL SPECIFICATION	HEAT TREATMENT	SCRAP SORT	TYPE OF CERTIFICATION

BHARAT HEAVY ELECTRICALS LTD.,
BOILER PLANT UNIT, TIRUCHIRAPALLI-14

FIRST ANGLE	SCALE	DRAWN	4. D. K. Srinivasan	TOTAL WT. (KG)
		CHECKED	D. Srinivasan	TYPE
ALL DIMENSIONS IN MILLIMETRES		APPROVED		NEW/OLD DRG. No.
		DATE	24.1.77	

CAUTION

THE INFORMATION CONTAINED IN THIS DRAWING IS THE PROPERTY OF BHARAT HEAVY ELECTRICALS LIMITED, BOILER PLANT UNIT, TIRUCHY-620014, AND SHALL NOT BE USED WITHOUT THEIR EXPRESS WRITTEN PERMISSION IN ANY FORM OR PART THEREOF FOR ANY OTHER PURPOSE THAN FOR WHICH IT IS SENT TO YOU.

STUD

DRAWING No. **3-V-S000-09338**

REVISION **05**

REV DATE	03	26-3-74	ALTERED: N.D. PAL	MD
REV DATE	01	17-9-77	ALTERED: N. D. Srinivasan	MD
SL. NO 4 IS INCLUDED				
SL. No. 2 INCLUDED.				
In Sl No: 3 Dimension L INCREASED FROM 30 TO 40				

3-V-0000-20723/8
DRAWING NO.

12.5 / 3.2

SL No.	DRAWING NO.	COMP. CODE	MATL. SPECN.	DIMENSIONS												FINISHED WT IN KGS	
				Md	P	L	S	H	K	X	X1	R	ød	øD	B		C
01	3-V-0001-20723/3	964521920000	ASTM A193 B7, CERTIFY	M8	1.25	30	30	5.5	-	2.5	3.5	0.4	8	12.6	13	15	0.02
02	3-V-0002-20723/3	964521930000		M10	1.5	16	16	7	-	3	4.5	0.4	10	16.5	17	19.6	0.02
03	3-V-0003-20723/3	964521940000		M10	1.5	20	20	7	-	3	4.5	0.4	10	16.5	17	19.6	0.02
04	3-V-0004-20723/3	964521950000		M12	1.75	20	20	8	-	3.5	5	0.6	12	18	19	21.9	0.03
05	3-V-0005-20723/3	964521960000		M20	2.5	60	46	13	5	5	-	0.8	20	29	30	34.6	0.23
06	3-V-0006-20723/3	964521970000		M24	3	90	54	15	6	6	-	0.8	24	34	36	41.6	0.45
07	3-V-0007-20723/3	964521980000		M30	3.5	110	66	19	7	7	-	1.0	30	44	46	53.1	0.88
08	3-V-0008-20723/3	964522410000		M16	2	50	38	10	4	4	-	0.6	16	23	24	27.7	0.10
09	3-V-0009-20723/3	964523140000		M20	2.5	55	46	13	5	5	-	0.8	20	29	30	34.6	0.22
10	3-V-0010-20723/2	964533300000		M16	2	90	60	10	4	4	-	0.6	16	23	24	27.7	0.16
11	3-V-0011-20723/2	964568210000		M20	2.5	85	46	13	5	5	-	0.8	20	29	30	34.6	0.31
12	3-V-0012-20723/2	964533560000		M20	2.5	126	70	13	5	5	-	0.8	20	29	30	34.6	0.43
13	3-V-0013-20723/1	964535750000		M30	3.5	120	76	19	7	7	-	1.0	30	44	46	53.1	0.95
14	3-V-0014-20723	964655090000		M16	2	75	38	16	4	4	-	0.6	16	23	24	27.7	0.14
15	3-V-0015-20723	964655100000		M24	3	141	40	15	6	6	-	0.8	24	34	36	41.6	0.64
16	3-V-0016-20723	964655120000		M20	2.5	70	25	14	5	5	-	0.8	20	26	30	34.6	0.27

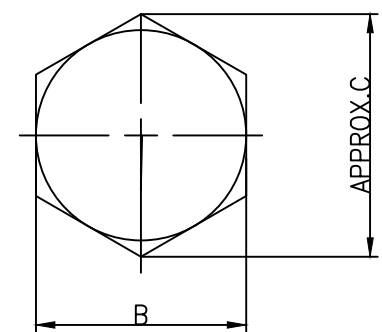
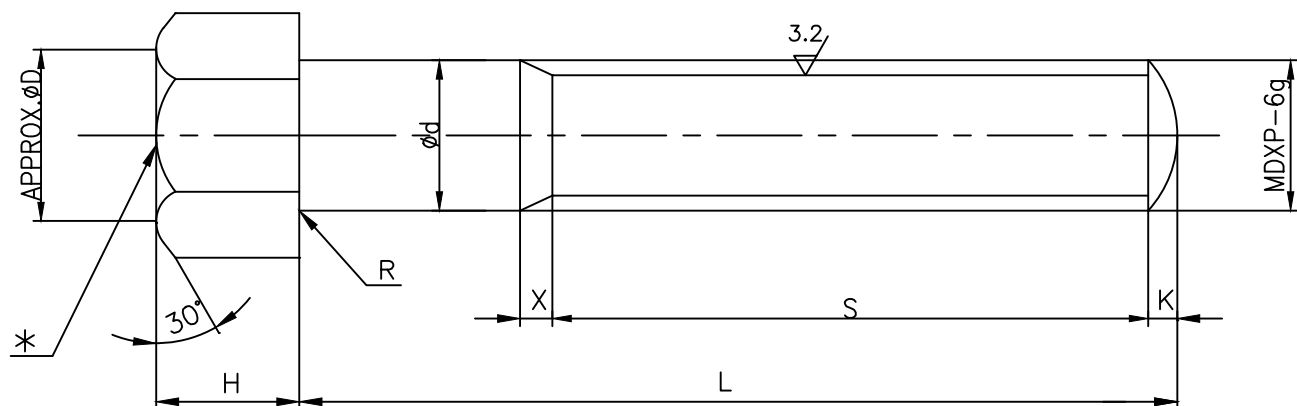

NOTES:

- * PUNCH MATERIAL MARK B7 FOR A193-B7.
- QUALITY REQUIREMENTS SHALL BE AS PER LATEST TDC 5:164.

REDRAWN WITH REV.7 ON 12.04.08

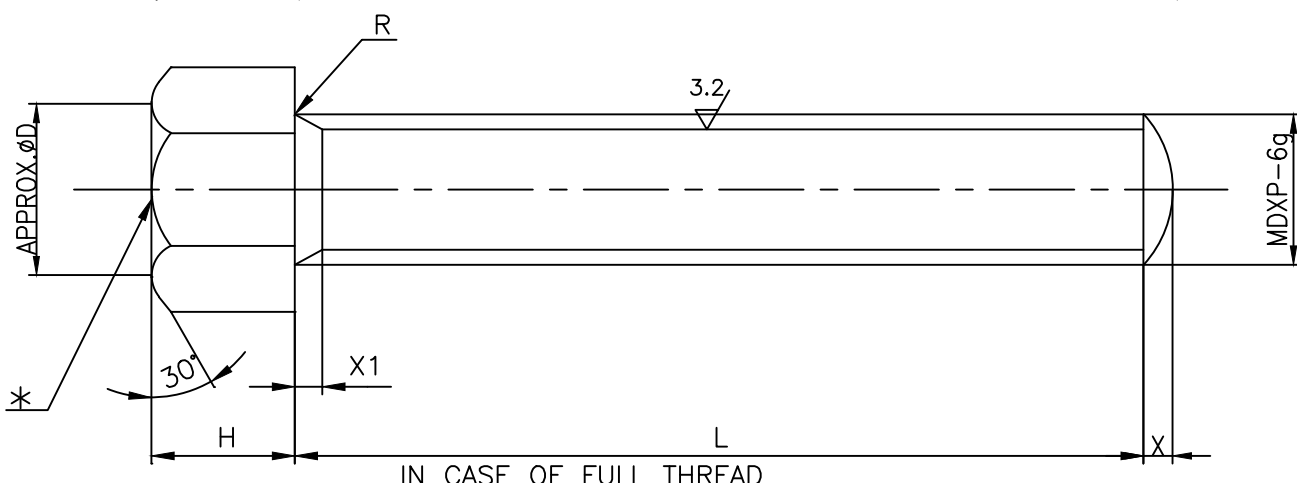

IN CASE OF FULL THREAD

REV 8	DATE 04.03.13	ALTERED DEEPAKRAJ CHD & APPD M.RAJAKUMAR	REV 7	DATE 12.04.08	ALTERED VB CHD & APPD KRS & M.R.K
SL.No.15 AND 16 INCLUDED.			DRAWING CONVERTED AS SOFT COPY		
			DCP No.800813		

CAUTION: The information on this document is the property of BHARAT HEAVY ELECTRICALS LTD. It must not be used directly or indirectly in any way detrimental to the interest of the company.

NO OFF	DESCRIPTION	MATL CODE	MATL SPECN	HEAT TREATMENT	SCRAP SORT	NET WT (kg)	GROSS WT (kg)	DRAWING No	ITEM No
	TYPE OF PRODUCT OR NAME OF CUSTOMER/PROJECT								
	BHARAT HEAVY ELECTRICALS LTD. UNIT: HIGH PRESSURE BOILER PLANT. TIRUCHIRAPALLI 620014.	DRN	V.BAIRAVAN	SIGN		DATE	12.04.08	NO.OF VAR.	
		CHD	M.RAJASEKARAN			DATE	12.04.08		
		APPD	M.RAJAKUMAR			DATE	12.04.08		
	DEPT VL	365-121	SCALE	WEIGHT (KG).	REFERENCE INFORMATION				
	CODE 320		NTS	-	PT-42				
	TITLE	BOLT			CARD CODE	DRAWING NO.		REV	
		U 01	3-V-0000-20723			8			

SL. No.	DRAWING No.	MATERIAL DETAILS					DIMENSIONS							NET Wt. (kg)	COMP. CODE	SL. No.	
		SPECN.	SIZE	CODE	HEAT TREATMENT	SCRAP SORT	GROSS WT. (kg)	L	L1	L2 (+17)	X	C	Md				1713
1	3.V.1134.03661/1	ASTM A193-B7, CERTIFY	φ16x65	15039115	HARDENED & TEMPERED	20	0.103	45	26	13 ^{+1.8}	3.5	1.5	M10	0.27	0.036	930595160000	1
2	3.V.1135.03661/1		φ20x85	15039084			0.210	55	38	23 ^{+2.1}	5	2	M16	0.27	0.123	930595170000	2
3	3.V.1132.03661/1		φ25x90	15039086			0.347	60	46	23 ^{+2.1}	6	2.5	M20	0.33	0.205	930595180000	3
4	3.V.2663.03661/1		φ20x75	15039084			0.185	46	35	23 ^{+2.1}	5	2	M16	0.27	0.12	930602550000	4
5	3.V.1076.03661		φ16x80	15039115			0.13	55	35	20 ^{+2.1}	3.5	1.5	M10	0.27	0.05	930608660000	5
6	3.V.1705.03661		φ25x100	15039086			0.386	70	46	23 ^{+2.1}	6	2.5	M20	0.33	0.21	930609390000	6
7	3.V.5402.03661		φ20x118	15039084			0.29	85	38	23 ^{+2.1}	5	2	M16	0.27	0.19	930678070000	7
8	3.V.2899.03661		φ25x110	15039086			0.424	75	30	32 ^{+2.8}	6	2.5	M20	0.33	0.26	931006060000	8
9	3.V.2956.03661		φ16x70	15039115			0.11	45	25	20 ^{+2.1}	3.5	1.5	M10	0.27	0.04	931017320000	9
10	3.V.2961.03661		φ20x100	15039084			0.25	70	40	23 ^{+2.1}	5	2	M16	0.27	0.15	931019960000	10
11	3.V.P208.03661		φ25x110	15039086			0.42	65	35	35 ^{+2.8}	6	2.5	M20	0.33	0.25	931026230000	11
12	3.V.B555-03661	φ25x95	15039086	0.36	50	35	35 ^{+2.8}	6	2.5	M20	0.33	0.21	931035410000	12			
13	3.V.5142-03661	A193 B16	φ32x130	15039165	0.82	85	60	35 ^{+2.8}	6	2.5	M27	0.33	0.54	931037190000	13		
14	3.V.5618-03661	A193-B7, CERTIFY	φ16x95	15039115	HARDENED, TEMPERED	20	0.15	67	25	20 ^{+2.1}	3.5	1.5	M10	0.27	0.05	931566030000	14

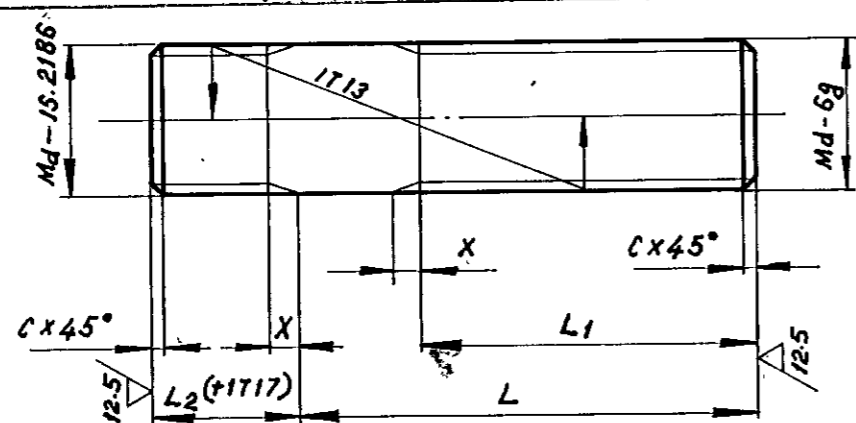

NO. OF PIECES	DESCRIPTION	SEM PRO./SEQ.NO.	INT. MAT. / SEQ. NO.	FINAL MATERIAL	SCRAP SORT	NET Wt (kg)	GROSS Wt (kg)	DRAWING NO.	ITEM NO.
---------------	-------------	------------------	----------------------	----------------	------------	-------------	---------------	-------------	----------

RETRACED WITH REV. No. 10 ON 15.6.95

BHARAT HEAVY ELECTRICALS LTD.
BOILER PLANT UNIT, TIRUCHIRAPALLI-14

REV.	DATE	ALTERED	REV.	DATE	ALTERED	REV.	DATE	ALTERED
		CHE & APPD.			CHE & APPD.			CHE & APPD.
		CHE & APPD.			CHE & APPD.			CHE & APPD.
		CHE & APPD.			CHE & APPD.			CHE & APPD.

FIRST ANGLE	SCALE	DRAWN	TOTAL NET WT. (kg)
	NTS	R.L. [Signature]	
		CHECKED: R.L. [Signature]	TYPE
		APPROVED: M.R.K. [Signature]	NEW/OLD DRG. NO
		DATE: 15.6.95	

CAUTION
 THE INFORMATION CONTAINED IN THIS DRAWING IS THE PROPERTY OF BHARAT HEAVY ELECTRICALS LTD., BOILER PLANT UNIT, TIRUCHY-14 AND SHALL NOT BE USED WITHOUT THEIR EXPRESS WRITTEN PERMISSION IN ANY FORM OR PART THEREOF FOR ANY OTHER PURPOSE THAN FOR WHICH IT IS SENT TO YOU.

STUD

DRAWING NO: **3.V.0000.03661**

REVISION: **10**

ALL DIMENSIONS ARE IN MILLIMETRES. FOR TOLERANCES OF UNTOLERANCED DIMENSIONS DURING MANUFACTURE REFER RELEVANT QCP / QP.

1 | 8ZL0Z-0000-A-3
DRAWING NO.

12.5 / 3.2 /

SL No.	DRAWING NO.	COMP. CODE	MATL. SPECN.	DIMENSIONS													NET WT (Kgs)	REMARKS
				MD	P	L	S	H	K	X	X1	R	ød	B	C			
01	3-V-0001-20728/02	964524380000		M16	2	70	70	10	-	4	6	0.6	16	23	24	27.7	0.14	
02	3-V-0002-20728/02	964524390000		M39	4	120	80	25	4	8	-	1.2	39	57.5	60	69.3	1.73	
03	3-V-0003-20728/02	964524400000		M14	2	120	30	10	2	4	-	0.6	14	20	21	24.2	0.11	
04	3-V-0004-20728/02	964526840000		M5	0.8	25	25	3.5	-	2	2	0.2	5	7	8.3	9.2	0.01	
05	3-V-0005-20728/02	964528590000		M30	3.5	80	45	19	4	7	-	1.0	30	44	46	53.1	0.57	
06	3-V-0006-20728/02	964529810000		M20	2.5	70	50	13	5	5	-	0.8	20	29	30	34.6	0.27	
07	3-V-0007-20728/02	964530600000		M6	1	16	16	4	-	2	3	0.25	6	9.8	10	11.5	0.01	
08	3-V-0008-20728/02	964531710000		M20	2.5	95	40	13	5	5	-	0.8	20	29	30	34.6	0.33	
09	3-V-0009-20728/03	964531720000		M24	3	85	50	15	6	6	-	0.8	24	34	36	41.6	0.40	
10	3-V-0010-20728/02	964605960000	ASTM A193 B7	M8	1.25	20	20	5.5	-	2.5	3.75	0.5	8	12.6	13	15.0	0.011	
11	3-V-0011-20728/02	964605970000	CERTIFY	M8	1.25	25	25	5.5	-	2.5	3.75	0.5	8	12.6	13	15.0	0.012	
12	3-V-0012-20728/02	964532250000		M24	3	120	60	15	6	6	-	0.8	24	34	36	41.6	0.55	
13	3-V-0013-20728/02	964533230000		M36	4	100	60	23	4	8	-	2	36	53	55	63.5	1.30	
14	3-V-0014-20728/01	964534120000		M16	2	120	70	10	4	4	-	0.6	16	23	24	27.7	0.22	
15	3-V-0015-20728	964535410000		M16	2	20	20	10	-	4	6	0.6	16	23	24	27.7	0.04	
16	3-V-0016-20728	964650030000		M24	3	75	40	15	6	6	-	0.8	24	34	36	41.6	0.34	
17	3-V-0017-20728	964535780000		M20	2.5	110	60	13	5	5	-	0.8	20	29	30	34.6	0.38	
18	3-V-0018-20728	964535900000		M36	4	130	80	23	4	8	-	2	36	53	55	63.5	1.54	

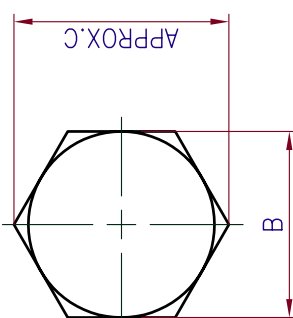
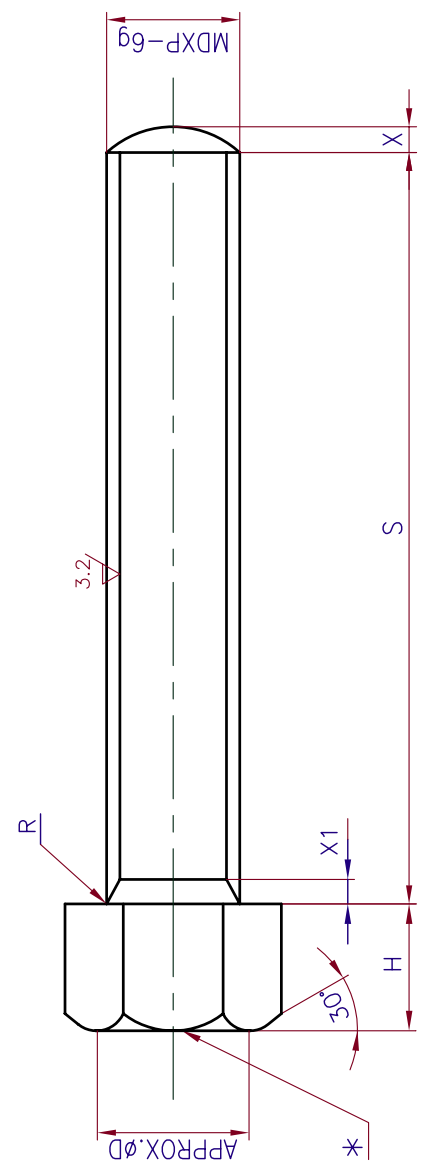
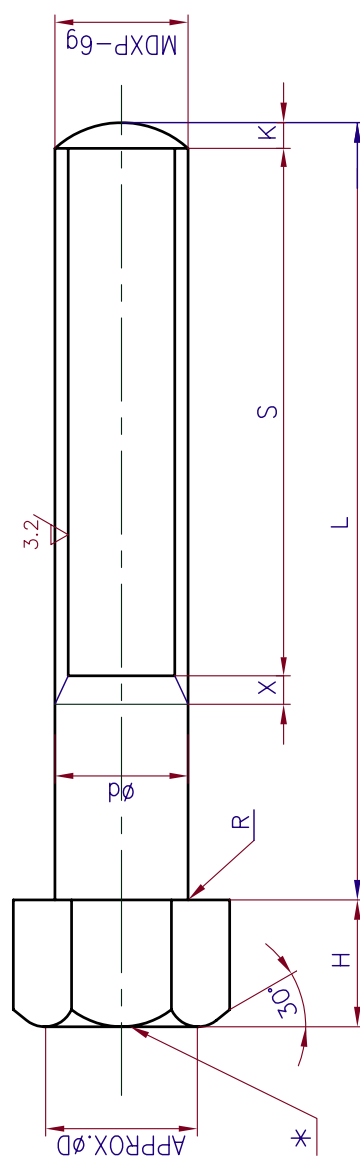

NOTES:

- * PUNCH MATERIAL MARK B7 FOR A193 B7.
- QUALITY REQUIREMENTS SHALL BE AS PER LATEST TDC.5:164

TYPE OF PRODUCT
OR NAME OF
CUSTOMER/PROJECT

RETRACED WITH REV.10 DATED 01.02.03



BHARAT HEAVY ELECTRICALS LTD.,
UNIT: HIGH PRESSURE BOILER PLANT.
TIRUCHIRAPALLI-620014.

DEPT VL
CODE 320
TITLE

DRN V.BAIRAVAN
CHD K.RAJASEKARAN
APPD M.RAJAKUMAR

SCALE /
WEIGHT (KG) -
REFERENCE INFORMATION
PT-42
CAD REF.3V020728

NO. OF OFF
DESCRIPTION
MATL CODE
MATL SPECN
HEAT TREATMENT
SCRAP SORT
NET WT (kg)
GROSS WT (kg)
DRAWING No
ITEM No

BOLT

CARD CODE
U 01

DRAWING NO.
3-V-0000-20728

REV
11

CAUTION: The information on this document is the property of BHARAT HEAVY ELECTRICALS LTD. It must not be used directly or indirectly in any way detrimental to the interest of the company.

REV	DATE	ALTERED VB	REV	DATE	ALTERED VB
11	27.04.05	CHD & APPD KRS & MRK	10	01.02.03	CHD & APPD

SL. NO.18 INCLUDED.
SL. NO.17 INCLUDED.

IN CASE OF FULL THREAD

3-V-000-25897

DRAWING NO.

12.5 / 3.2

SL.NO.	DRAWING NO.	COMP. CODE	MATL. SPECN.	DIMENSIONS				NET WT. (IN KGS.)
				Md	P	L	K	
1.	3-V-0001-25897/01	964658350000	ASTM A193-B8M CL.2, CERTIFY	M10	1.5	55	2	0.034
2.	3-V-0002-25897/01	964658360000		M16	2	55	2.5	0.087
3.	3-V-0003-25897/01	964658310000		M20	2.5	130	2.5	0.320
4.	3-V-0004-25897/01	964658320000		M20	2.5	150	2.5	0.370
5.	3-V-0005-25897/01	964658340000		M27	3	180	2.5	0.809
6.	3-V-0006-25897/02	964658330000		M30	3.5	185	2.5	1.027
7.	3-V-0007-25897/01	964658930000		M24	3	150	2.5	0.55
8.	3-V-0008-25897/01	964658940000		M33	3.5	220	2.5	1.5

NOTES :

- * PUNCH MATERIAL MARK B8M FOR A193 - B8M
- QUALITY REQUIREMENTS SHALL BE AS PER LATEST APPLICABLE QUALITY WORK INSTRUCTION.

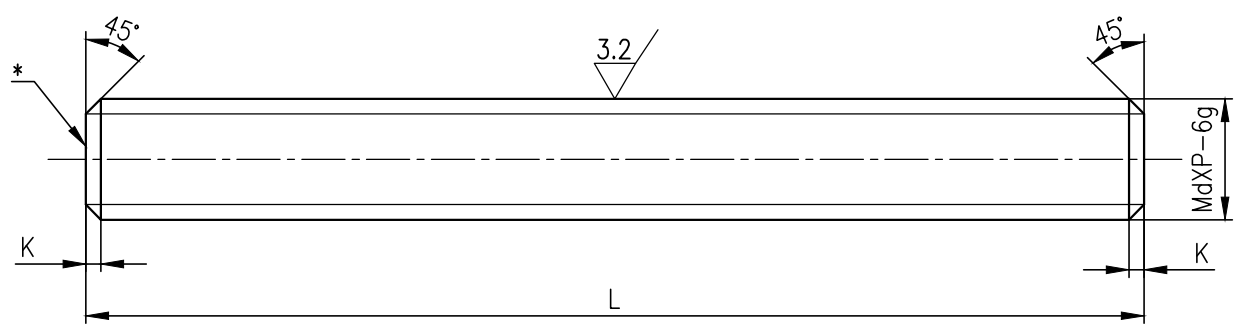

REV	DATE	ALTERED	R.P.SINGH	REV	DATE	ALTERED	R.P.SINGH
03	26.06.20	CHD & APPD	SAMEER & SSK	02	13.11.19	CHD & APPD	SAMEER & SSK
MATL. SPECIFICATION UPDATED.				M30 PITCH 3.5 WAS 3.			

CAUTION: The information on this document is the property of BHARAT HEAVY ELECTRICALS LTD. It must not be used directly or indirectly in any way detrimental to the interest of the company.

NO OFF	DESCRIPTION	MATL CODE	MATL SPECN	HEAT TREATMENT	SCRAP SORT	NET WT (kg)	GROSS WT (kg)	DRAWING No	ITEM No
TYPE OF PRODUCT OR NAME OF CUSTOMER/PROJECT									
DEPT VL		Bharat Heavy Electricals Ltd. UNIT: HIGH PRESSURE BOILER PLANT. TIRUCHIRAPALLI_620014.			DRN	R.P.SINGH	SIGN	DATE 27.03.18	NO.OF VAR.
CODE 320					CHD	S.SATHEES		DATE 27.03.18	
					APPD	K.RAJASEKARAN		DATE 27.03.18	
TITLE		STUD			SCALE	NTS	WEIGHT (KG).	REFERENCE INFORMATION	NO. OF ITEMS
					CARD CODE	U 01	DRAWING NO.	3-V-0000-25897	REV 03

FOR TOLERANCES OF UNTOLERANCED DIMENSIONS

ALL DIMENSIONS ARE IN MILLIMETRES.
DURING MANUFACTURE REFER RELEVANT QCP/QP

CAUTION: The information on this document is the property of BHARAT HEAVY ELECTRICALS LTD. It must not be used directly or indirectly in any way detrimental to the interest of the company.

REV 01	DATE 29.10.18	ALTERED CHD & APPD	R.P.SINGH SSK & KRS	REV	DATE	ALTERED
				CHD & APPD		
MATERIAL SPECIFICATION CHANGED FROM B8MA TO Gr.8M				GROUP No. 0006 & 0007 ADDED		

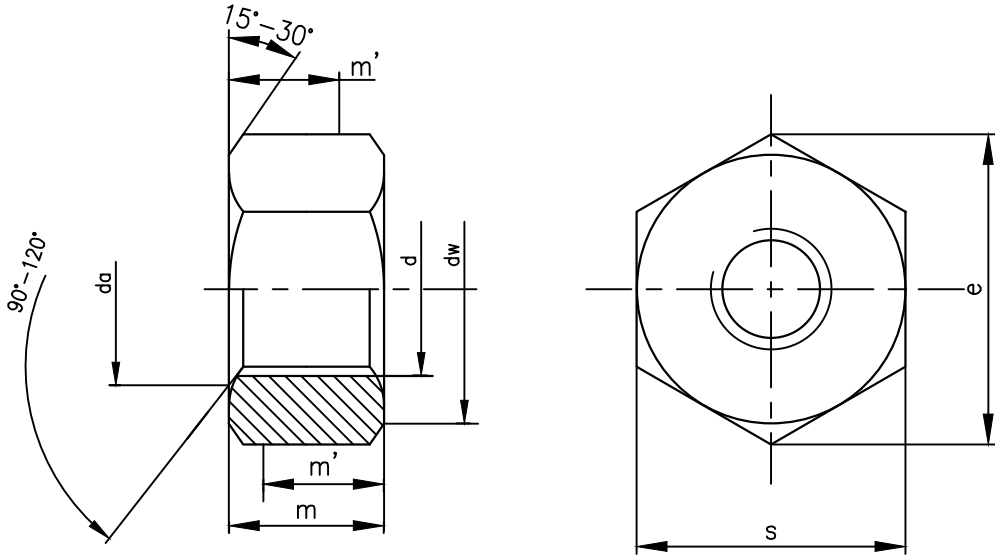

NOTE:- FOR OTHER DIMENSIONS/DETAILS REFER IS:1364.

MATERIAL CODE	DRAWING NO	Thread Size	da		dw	e	m		m'		S		WEIGHT
			d	Min	Max	Min	Min	Max	Min	Max	Min	Max	
964658380000	4-V-0001-27368	M10	10	10.8	14.6	17.77	10	9.64	7.7	16	15.73	0.0108	
964658390000	4-V-0002-27368	M20	20	21.6	27.7	32.95	20.7	19.40	15.5	30	29.16	0.0645	
964658400000	4-V-0003-27368	M27	27	29.16	38	45.2	24.7	22.6	18.1	41	40	0.185	
964658410000	4-V-0004-27368	M30	30	32.4	42.7	50.85	30.7	29.10	23.3	46	45	0.253	
964658440000	4-V-0005-27368	M12	12	13.0	16.6	20.03	12	11.57	9.30	18	17.73	0.0165	
964658970000	4-V-0006-27368	M33	33	35.6	46.6	55.37	33	31.4	25.1	50	49	0.30	
964658960000	4-V-0007-27368	M24	24	25.9	33.2	39.55	24.2	22.9	18.3	36	35	0.11	

HEXAGON NUT		ASTM A194 Gr.8M, CERTIFY											
NO OFF	DESCRIPTION	MATL CODE	MATL SPECN	HEAT TREATMENT	SCRAP SORT	NET WT (kg)	GROSS WT (kg)	DRAWING No		ITEM No			
BHARAT HEAVY ELECTRICALS LTD., UNIT: HIGH PRESSURE BOILER PLANT. TIRUCHIRAPALLI 620014.						DRN	NAME R.P.SINGH		SIGN	DATE 16.04.18	NO.OF VAR		
						CHD	S.SATHEES			16.04.18			
						APPD	K.RAJASEKARAN			16.04.18			
DEPT VL		SCALE NTS		WEIGHT (KG). REFER TABULATION		REFERENCE INFORMATIONS ---					NO. OF ITEMS		
CODE 320													
TITLE HEX NUT						CARD CODE U 01	DRAWING NO. 4-V-0000-27368				REV 01		

REV	DATE	ALTERED V.B
4	15.03.04	CHD & APPD M.R.K
SL.No.08 INCLUDED.		

12.5 / 3.2

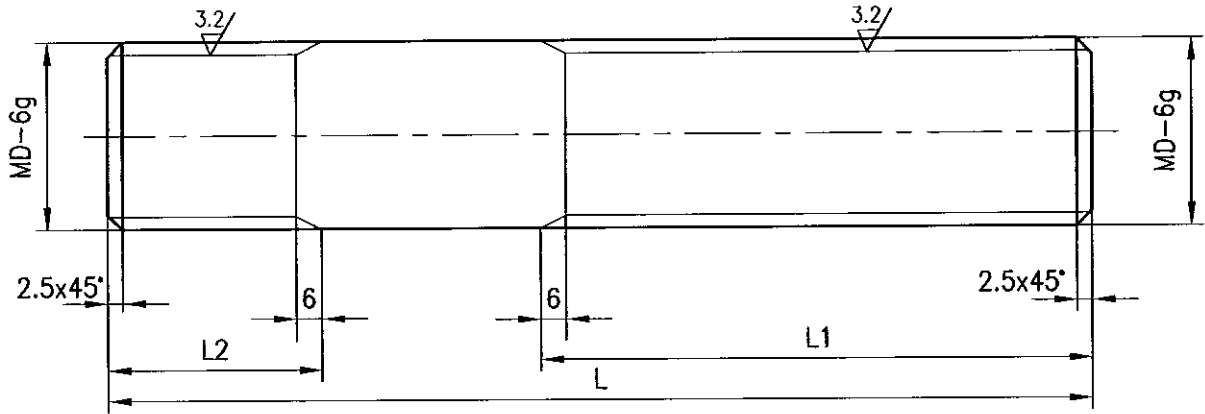

REDRAWN WITH REV.4 ON 15.03.04

CAUTION: The information on this document is the property of BHARAT HEAVY ELECTRICALS LTD. It must not be used directly or indirectly in any way detrimental to the interest of the company.

SL. No.	COMP. CODE	MATL. CODE	MATL SPECN.	SCRAP SORT	NET WT(Kg)	GROSS WT(Kg)	L	L1	L2	MD-6g		
08	931301830000	153391390000	SA105, NR CERTIFY	10	1.10	1.70	440	120	20	M20		
	4-V-NA06-06800	ø25x450			0.80	1.20	300	120	20	M20		
07	931097630000	153391390000			0.40	1.0	250	50	16	M16		
	4-V-N846-06800	ø25x310			0.50	0.85	210	100	20	M20		
06	931191430000	153391390000			0.35	0.60	140	80	20	M20		
	4-V-W084-06800	ø25x260			0.70	1.10	270	120	20	M20		
05	931086530000	153391390000			0.94	1.50	380	100	20	M20		
	4-V-N722-06800	ø25x220			0.42	0.72	170	100	20	M20		
04	931055020000	153391390000			DIMENSIONS							
	4-V-K591-06800	ø25x150										
03	931054810000	153391390000	DIMENSIONS									
	4-V-N231-06800	ø25x280										
02	931054750000	153391390000	DIMENSIONS									
	4-V-C434-06800	ø25x390										
01	931051010000	153391390000	DIMENSIONS									
	4-V-N224-06800	ø25x180										



BHARAT HEAVY ELECTRICALS LTD.,
 UNIT: HIGH PRESSURE BOILER PLANT.
 TIRUCHIRAPALLI 620014.

DRN	NAME	SIGN	DATE	NO. OF VAR
CHD	V.BAIRAVAN		15.03.04	
APPD	R.L.NARAYANAN		15.03.04	
	M.RAJAKUMAR		15.03.04	

DEPT VL	SCALE	WEIGHT (KG).	REFERENCE INFORMATION	NO. OF ITEMS
CODE 320	N T S		CAD REF. C406800	
TITLE	CARD CODE	DRAWING NO.	REV	
INDICATOR STUD	U 01	4-V-0000-06800	4	

ALL DIMENSIONS ARE IN MILLIMETRES. FOR TOLERANCES OF UNTOLERANCED DIMENSIONS DURING MANUFACTURE REFER RELEVANT QCP / QP.

DRAWING NO. 6ZL0Z-0000-A-3									
SL No.	DRAWING No.	COMP. CODE	MATL. SPECN.	DIMENSIONS				WT(KG)	
				MDxP-6g	L	K			
01	3-V-0001-20729/02	964524410000	A193 B7, CERTIFY	M30x3	185	3		1.03	
02	3-V-0002-20729/02	964524420000		M30x3	280	3		1.55	
03	3-V-0003-20729/02	964524430000		M42x3	440	3		4.79	
04	3-V-0004-20729/02	964524440000		M48x3	520	3		7.39	
05	3-V-0005-20729/02	964526850000		M20x2.5	195	2.5		0.48	
06	3-V-0006-20729/02	964527050000		M30x3	270	3		1.49	
07	3-V-0007-20729/02	964527260000		M36x3	270	3		2.04	
08	3-V-0008-20729/02	964527270000		M36x3	500	3		3.78	
09	3-V-0009-20729/02	964527280000		M36x3	310	3		2.34	
10	3-V-0010-20729/02	964527290000		M20x2.5	165	2.5		0.52	
11	3-V-0011-20729/02	964527300000		M22x2.5	180	2.5		0.54	
12	3-V-0012-20729/02	964527310000		M24x3	190	3		0.68	
13	3-V-0013-20729/02	964527320000		M24x3	210	3		0.75	
14	3-V-0014-20729/02	964527330000		M24x3	250	3		0.89	
15	3-V-0015-20729/01	964534230000		M12x1.75	90	2		0.09	
16	3-V-0016-20729/01	964534240000		M16x2	125	2		0.20	
17	3-V-0017-20729/01	964534250000		M20x2.5	150	2.5		0.47	
18	3-V-0018-20729	964651670000		M42x3	220	3		2.4	
19	3-V-0019-20729	964660060000		M39x3	480	3		4.5	
20	3-V-0020-20729	964653440000		M39x3	240	3		2.2	
21	3-V-0021-20729	964653450000		M39x3	280	3		2.6	
22	3-V-0022-20729	964654080000		M42x3	340	3		3.5	
23	3-V-0023-20729	964655060000		M48x3	300	3		4.20	
24	3-V-0024-20729	964654870000		M30	240	3		1.3	
25	3-V-0025-20729	964655080000		M33	220	3.5		1.5	

SL No.	DRAWING No.	COMP. CODE	MATL. SPECN.	DIMENSIONS				WT(KG)
				MDxP-6g	L	K		
26	3-V-0026-20729/02	964524450000	A193 B16, CERTIFY	M30x3	185	3		1.03
27	3-V-0027-20729/02	964524460000		M30x3	280	3		1.55
28	3-V-0028-20729/02	964524470000		M42x3	440	3		4.79
29	3-V-0029-20729/02	964524480000		M48x3	520	3		7.39
30	3-V-0030-20729/02	964526860000		M20x2.5	195	2.5		0.48
31	3-V-0031-20729/02	964527060000		M30x3	270	3		1.49
32	3-V-0032-20729/02	964527340000		M36x3	270	3		2.04
33	3-V-0033-20729/02	964527350000		M36x3	500	3		3.78
34	3-V-0034-20729/02	964527360000		M36x3	310	3		2.34
35	3-V-0035-20729/02	964527370000		M20x2.5	165	2.5		0.52
36	3-V-0036-20729/02	964527380000		M22x2.5	180	2.5		0.54
37	3-V-0037-20729/02	964527390000		M24x3	190	3		0.68
38	3-V-0038-20729/02	964527400000		M24x3	210	3		0.75
39	3-V-0039-20729/02	964527410000		M24x3	250	3		0.89
40	3-V-0040-20729/01	964534260000		M12x1.75	90	2		0.09
41	3-V-0041-20729/01	964534270000		M16x2	125	2		0.20
42	3-V-0042-20729/01	964534280000		M20x2.5	150	2.5		0.47
43	3-V-0043-20729	964651700000		M42x3	220	3		2.4
44	3-V-0044-20729	964660070000		M39x3	480	3		4.5
45	3-V-0045-20729	964652610000		M39x3	240	3		2.2
46	3-V-0046-20729	964652620000		M39x3	280	3		2.6
47	3-V-0047-20729	964654090000		M42x3	340	3		3.5
48	3-V-0048-20729	964654150000		M27x3	180	3		0.8
49	3-V-0049-20729	964655740000		M33	220	3.5		1.5

12.5 / 3.2

NOTES:-

1. QUALITY REQUIREMENTS SHALL BE AS PER LATEST APPLICABLE QUALITY WORK INSTRUCTION.
- * 2. PUNCH MATL.MARK B7 FOR A193-B7 AND B16 FOR A193-B16

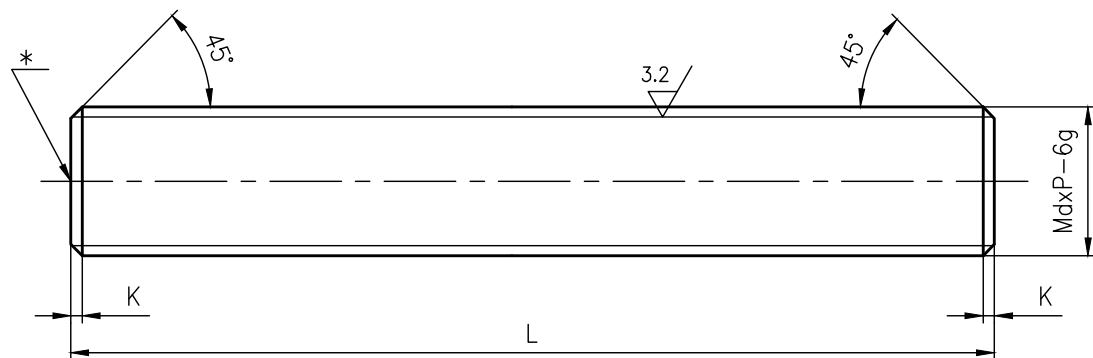

REV	DATE	ALTERED	GANESH	REV	DATE	ALTERED	GANESH
13	28.05.13	CHD & APPDK	RAJASEKARAN	12	14.03.13	CHD & APPD	M.RAJAKUMAR
		SL. No. 49 INCLUDED.				SL. No. 25 INCLUDED.	

CAUTION: The information on this document is the property of BHARAT HEAVY ELECTRICALS LTD. It must not be used directly or indirectly in any way detrimental to the interest of the company.

NO OFF	DESCRIPTION	MATL CODE	MATL SPECN	HEAT TREATMENT	SCRAP SORT	NET WT (kg)	GROSS WT (kg)	DRAWING No	ITEM No
	TYPE OF PRODUCT OR NAME OF CUSTOMER/PROJECT								
	BHARAT HEAVY ELECTRICALS LTD., UNIT: HIGH PRESSURE BOILER PLANT. TIRUCHIRAPALLI-620014.	DRN	V.BAIRAVAN	SIGN		DATE	15.3.04	NO.OF VAR.	
		CHD	K.RAJASEKARAN			DATE	15.3.04		
		APPD	M.RAJAKUMAR			DATE	15.3.04		
DEPT	VL	SCALE	WEIGHT (KG).	REFERENCE INFORMATION				NO. OF ITEMS	
CODE	320	NTS	REF. TABLE	CAD REF:-T320729					
TITLE			CARD CODE	DRAWING NO.				REV	
STUD			U 01	3-V-0000-20729				13	

ALL DIMENSIONS ARE IN MILLIMETRES. FOR TOLERANCES OF UNTOLERANCED DIMENSIONS DURING MANUFACTURE REFER RELEVANT QCP / QP.

3-V-0000-20717
DRAWING NO.

12.5 / 3.2

SL. NO.	DRAWING NO.	MATL. SPECN.	COMP.CODE	DIMENSIONS						FINISHED WT(kg)
				Md	P	H	B	C	∅D	
01.	3-V-0001-20717	A194-2H, CERTIFY	96 452 160 0000	M22	2.5	18	32	37	31	0.07
02.	3-V-0002-20717		96 452 161 0000	M30	3	24	46	53.1	44	0.21
03.	3-V-0003-20717		96 452 312 0000	M42	3	42	65	75	62	0.29
04.	3-V-0004-20717/1		96 452 450 0000	M39	4	32	60 [△]	65	55	0.24
05.	3-V-0005-20717		96 452 688 0000	M5	0.8	4	8.3	9.2	7	0.01
06.	3-V-0006-20717		96 452 932 0000	M48	3	48	75	86.5	72	0.94
07.	3-V-0007-20717		96 453 057 0000	M52	3	52	80	92.4	77	1.2
08.	3-V-0008-20717		96 460 645 0000	M30	3	30	46	53.1	44	0.23
17.	3-V-0017-20717		96 453 358 0000	M22	2.5	22	32	37	31	0.09
18.	3-V-0018-20717/1		96 466 008 0000	M39	3	39	60 [△]	65	55	0.29
20.	3-V-3234-20717		96 465 274 0000	M33	3.5	33	50	57.7	49	0.32

SL. NO.	DRAWING NO.	MATL. SPECN.	COMP.CODE	DIMENSIONS						FINISHED WT(kg)
				Md	P	H	B	C	∅D	
09.	3-V-0009-20717/1	A194-Gr.7, CERTIFY	96 452 309 0000	M22	2.5	18	32	37	31	0.07
10.	3-V-0010-20717/1		96 452 310 0000	M30	3	24	46	53.1	44	0.21
11.	3-V-0011-20717/1		96 452 311 0000	M42	3	42	65	75	62	0.29
12.	3-V-0012-20717/1		96 453 058 0000	M52	3	52	80	92.4	77	1.2
13.	3-V-0013-20717/1		96 460 647 0000	M30	3	30	46	53.1	44	0.23
14.	3-V-0014-20717/2		96 453 203 0000	M39	4	32	60 [△]	65	55	0.24
15.	3-V-L793-20717/1		96 460 741 0000	M42	4.5	42	65	75	62	0.29
16.	3-V-0016-20717/1		96 453 357 0000	M22	2.5	22	32	37	31	0.09
19.	3-V-0019-20717/1		96 466 009 0000	M39	3	39	60 [△]	65	55	0.29
21.	3-V-3237-20717		96 465 275 0000	M33	3.5	33	50	57.7	49	0.32

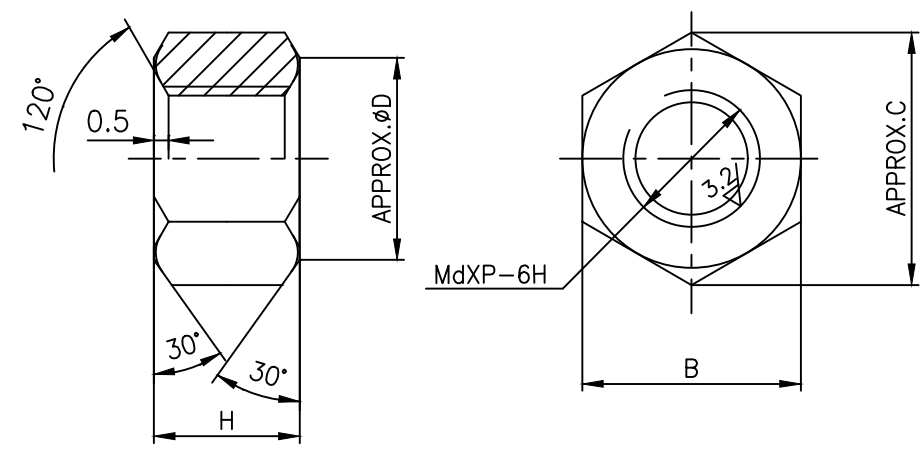

NOTES:-

- 01. LATEST APPLICABLE QUALITY WORK INSTRUCTION SHALL BE FOLLOWED IN ALL RESPECTS.

REV	DATE	ALTERED	BY	REV	DATE	ALTERED	BY
06	04.11.17	CHD & APPD	R.P.SINGH SSK & KRS	05	10.05.08	CHD & APPD	M.SRINIVASAN K.S.RAMAN
DIMENSIONS 60 WAS 56 FOR M39				SL.NO. 20 & 21 INCLUDED.			
DCP NO.802298							

CAUTION: The information on this document is the property of BHARAT HEAVY ELECTRICALS LTD. It must not be used directly or indirectly in any way detrimental to the interest of the company.

NO OFF	DESCRIPTION	MATL CODE	MATL SPECN	HEAT TREATMENT	SCRAP SORT	NET WT (kg)	GROSS WT (kg)	DRAWING No	ITEM No
-	-	-	-	-	-	-	-	-	-
TYPE OF PRODUCT OR NAME OF CUSTOMER/PROJECT									
BHARAT HEAVY ELECTRICALS LTD., UNIT: HIGH PRESSURE BOILER PLANT. TIRUCHIRAPALLI-620014.					DRN	NAME	SIGN	DATE	NO.OF VAR.
					CHD	K.RAJASEKARAN		17.3.07	
					APPD	M.RAJAKUMAR		17.3.07	
DEPT VL	SCALE	WEIGHT (KG).	REFERENCE INFORMATION			NO. OF ITEMS			
CODE 320	N T S		CAD REF: T320717 PT40						
TITLE						CARD CODE	DRAWING NO.	REV	
NUT						U 01	3-V-0000-20717	06	

9/890-0000-Λ-Σ
DRAWING NO.

SL. No.	DRAWING No.	COMP. CODE	MATL. SPECN.	S		e		m		øD	MATL. MARK	NET WT. (Kg.)
				MAX.	MIN.	MAX.	MIN.	MAX.	MIN.			
01	3.V.N073.06876/03	96 456 279	ASTM A194 - 2H, CERTIFY	22.22	21.59	25.65	24.61	12.80	11.79	1/2"-13 UNC -2B	2H	0.02
02	3.V.N025.06876/03	96 456 280		26.97	26.19	31.17	29.85	16.03	14.91	5/8"-11 UNC -2B	2H	0.03
03	3.V.N057.06876/03	96 456 281		31.75	30.78	36.65	35.10	19.25	18.03	3/4"-10 UNC -2B	2H	0.08
04	3.V.N065.06876/03	96 456 282		41.28	40.01	47.65	45.62	25.70	24.28	1"-8 UNC -2B	2H	0.17
05	3.V.N105.06876/03	96 456 283		46.02	44.60	53.16	50.85	29.93	27.41	1.1/8"-8 UN -2B	2H	0.27
06	3.V.N206.06876/02	96 456 431		36.52	35.41	42.16	40.37	22.47	21.16	7/8"-9 UNC -2B	2H	0.11
07	3.V.N204.06876/02	96 456 453	SA 307 Gr.B CERTIFY	31.75	30.78	36.65	35.10	19.25	18.03	3/4"-10 UNC -2B	307 B	0.08
08	3.V.N207.06876/02	96 456 454		36.52	35.41	42.16	40.37	22.47	21.16	7/8"-9 UNC -2B	307 B	0.11
09	3.V.F505.06876/01	96 456 683	ASTM A194 - 2H, CERTIFY	50.8	49.23	58.65	56.11	31.78	30.15	1.1/4"-8 UN -2B	2H	0.22
10	3.V.N848.06876	96 453 667		55.57	53.8	64.16	61.37	35.0	33.27	1.3/8"-8 UN -2B	2H	0.42
11	3.V.N827.06876	96 453 668		60.33	58.42	69.65	66.59	38.23	36.40	1.1/2"-8 UN -2B	2H	0.52
12	3.V.N846.06876/01	96 453 669		69.85	67.61	80.65	77.09	44.68	42.65	1.3/4"-8 UN -2B	2H	0.81
13	3.V.NK44.06876	96 465 904		65.07	63.02	75.15	71.84	41.45	39.53	1.5/8"-8 UN -2B	2H	0.68
14	3.V.NK45.06876	96 465 906		79.37	76.84	91.64	87.61	51.13	48.90	2"-8 UN -2B	2H	1.36

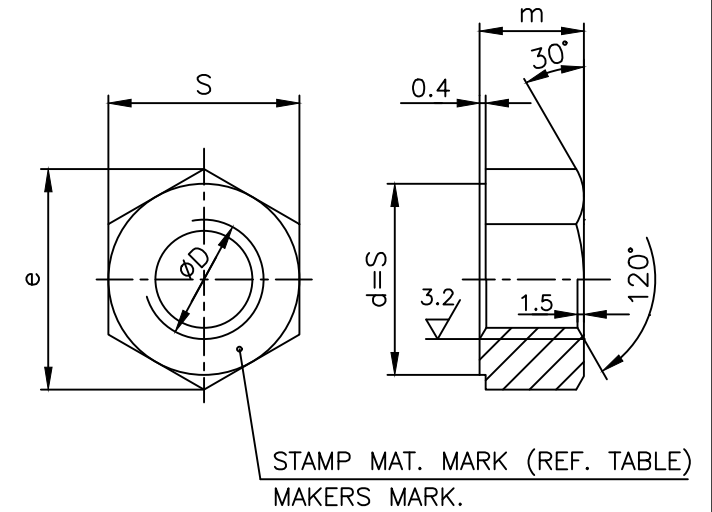

RETRACED WITH REV. 09 ON 26.11.18

NOTE:

1. FOR QUALITY REQUIREMENTS REFER LATEST APPLICABLE STANDARD(TDC:5:164).

NO OFF	DESCRIPTION	MATL CODE	MATL SPECN	HEAT TREATMENT	SCRAP SORT	NET WT (kg)	GROSS WT (kg)	DRAWING No	ITEM No
-	-	-	-	-	-	-	-	-	-

CAUTION: The information on this document is the property of BHARAT HEAVY ELECTRICALS LTD. It must not be used directly or indirectly in any way detrimental to the interest of the company.

TYPE OF PRODUCT OR NAME OF CUSTOMER/PROJECT

BHARAT HEAVY ELECTRICALS LTD.,
UNIT: HIGH PRESSURE BOILER PLANT.
TIRUCHIRAPALLI-620014.

DRN	M.SRINIVASAN	SIGN	DATE	NO.OF VAR.
CHD	N.DHANAPAL		22.04.96	
APPD	A.VISWANATHAN		22.04.96	

DEPT	VL	SCALE	WEIGHT (KG).	REFERENCE INFORMATIONS	NO. OF ITEMS
CODE	320	NTS	REF. TABLE	CAD: C306876	

TITLE HEX NUT

CARD CODE U 01

DRAWING NO. 3-V-0000-06876

REV 09

REV	DATE	ALTERED	R.P.SINGH
09	26.11.18	CHD & APPD SSK & KRS	
		SL. No.13 & 14 INCLUDED.	

DRAWING NO: 3-V-0000-23248

12.5 / 3.2

SL.No	DRAWING No.	MATERIAL	MATL. CODE	SIZE	L	WEIGHT IN Kgs.	MATL. MARK*
01	3-V-F522-23248/01	ASTM A193 Gr. B16	96 456 882 0000	7/8"-9UNC-2A	150	0.45	B16
02	3-V-F523-23248/01		96 456 883 0000	3/4"-10UNC-2A	133	0.30	B16
03	3-V-F524-23248/01		96 456 884 0000	1"-8UNC-2A	170	0.71	B16
04	3-V-F525-23248/01		96 456 885 0000	1.1/4"-8UN-2A	215	1.34	B16
05	3-V-F526-23248/01		96 456 886 0000	1.1/8"-8UN-2A	220	1.41	B16
06	3-V-F527-23248/02		96 456 887 0000	1.1/4"-8UN-2A	250	1.74	B16
07	3-V-0001-23248/01	ASTM A193-B8M CL.2, CERTIFY	96 465 635 0000	1/2"-13UNC-2A	80	0.08	B8M
08	3-V-0002-23248/01		96 465 636 0000	5/8"-11UNC-2A	86	0.13	B8M
09	3-V-0003-23248/01		96 465 637 0000	5/8"-11UNC-2A	105	0.16	B8M
10	3-V-0004-23248/01		96 465 638 0000	5/8"-11UNC-2A	118	0.18	B8M
11	3-V-0005-23248/01		96 465 639 0000	3/4"-10UNC-2A	120	0.26	B8M
12	3-V-0006-23248/01		96 465 640 0000	3/4"-10UNC-2A	133	0.29	B8M
13	3-V-0007-23248/01		96 465 641 0000	7/8"-9UNC-2A	150	0.45	B8M
14	3-V-0008-23248/01		96 465 642 0000	1"-8UNC-2A	135	0.53	B8M
15	3-V-0009-23248/01		96 465 643 0000	1"-8UNC-2A	158	0.62	B8M
16	3-V-0010-23248/01		96 465 644 0000	1"-8UNC-2A	170	0.67	B8M
17	3-V-0011-23248/01		96 465 645 0000	1.1/8"-8UN-2A	180	0.90	B8M
18	3-V-0012-23248/01		96 465 646 0000	1.1/4"-8UN-2A	215	1.32	B8M
19	3-V-0013-23248/01		96 465 647 0000	1.1/4"-8UN-2A	250	1.54	B8M
20	3-V-0014-23248/01		96 465 769 0000	7/8"-9UNC-2A	120	0.36	B8M
21	3-V-0016-23248/01		96 465 830 0000	1.1/8"-8UN-2A	140	0.87	B8M
22	3-V-0015-23248		96 465 794 0000	1/2"-13UNC-2A	95	0.09	B8M
23	3-V-F933-23248		96 465 938 0000	1.1/8"-8UN-2A	220	1.41	B8M

SL.No	DRAWING No.	MATERIAL	MATL. CODE	SIZE	L	WEIGHT IN Kgs.	MATL. MARK*	
24	3-V-0017-23248	ASTM A193 Gr. B7M	96 465 854 0000	1/2"-13UNC-2A	80	0.08	B7M	
25	3-V-0018-23248		96 465 855 0000	5/8"-11UNC-2A	86	0.13	B7M	
26	3-V-0019-23248		96 465 856 0000	5/8"-11UNC-2A	105	0.16	B7M	
27	3-V-0020-23248		96 465 857 0000	5/8"-11UNC-2A	118	0.18	B7M	
28	3-V-0021-23248		96 465 858 0000	3/4"-10UNC-2A	120	0.26	B7M	
29	3-V-0022-23248		96 465 859 0000	3/4"-10UNC-2A	133	0.29	B7M	
30	3-V-0023-23248		96 465 860 0000	7/8"-9UNC-2A	150	0.45	B7M	
31	3-V-0024-23248		96 465 861 0000	1"-8UNC-2A	135	0.53	B7M	
32	3-V-0025-23248		96 465 862 0000	1"-8UNC-2A	158	0.62	B7M	
33	3-V-0026-23248		96 465 863 0000	1"-8UNC-2A	170	0.67	B7M	
34	3-V-0027-23248		96 465 864 0000	1.1/8"-8UN-2A	180	0.90	B7M	
35	3-V-0028-23248		96 465 865 0000	1.1/4"-8UN-2A	215	1.32	B7M	
36	3-V-0029-23248		96 465 866 0000	1.1/4"-8UN-2A	250	1.54	B7M	
37	3-V-0030-23248		96 465 867 0000	7/8"-9UNC-2A	120	0.36	B7M	
38	3-V-0031-23248		96 465 868 0000	1.1/8"-8UN-2A	140	0.87	B7M	
39	3-V-NL92-23248		ASTM A193 Gr. B8M CL.2, CERTIFY	96 473 027 0000	1.1/4"-8UN-2A	150	0.94	B8M
40	3-V-Z135-23248			96 473 028 0000	1.1/4"-8UN-2A	180	1.11	B8M

NOTE

01. FOR QUALITY REQUIREMENTS: REFER LATEST APPLICABLE PROCEDURE.

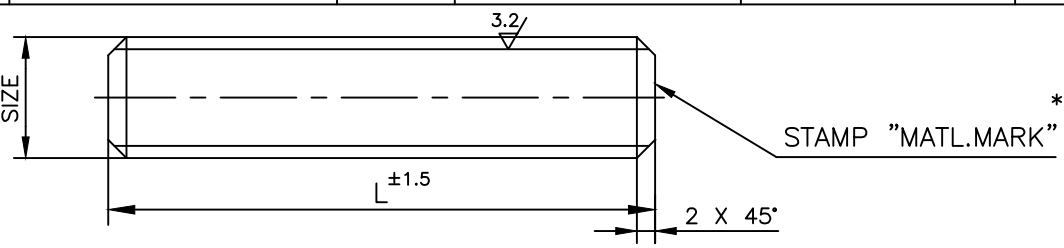

DCP No.	ALTD: TS	APPD: SSK	DCP No.	ALTD: RPS	APPD: SSK
-	CHD: RPS	DT: 07.09.22	-	CHD: SAB	DT: 22.02.21
REV 09	SL. No. 39 & 40 INCLUDED.		REV 08	3-V-F933-23248 INCLUDED.	
ZONE -			ZONE -		

NO OFF	DESCRIPTION	MATL CODE	MATL SPECN	HEAT TREATMENT	SCRAP SORT	NET WT (kg)	GROSS WT (kg)	DRAWING No.	ITEM No
-	-	-	-	-	-	-	-	-	-

CAUTION: The information on this document is the property of BHARAT HEAVY ELECTRICALS LTD. It must not be used directly or indirectly in any way detrimental to the interest of the company.

TYPE OF PRODUCT OR NAME OF CUSTOMER/PROJECT: REDRAWN WITH REV.5 ON 26.03.18

BHARAT HEAVY ELECTRICALS LTD., UNIT: HIGH PRESSURE BOILER PLANT. TIRUCHIRAPALLI-620014.	DRN	NAME	SIGN	DATE	NO. OF VAR.
	CHD	K.S.RAMAN		18.05.98	-
	APPD	N.NAGARAJAN		18.05.98	-

DEPT VL	SCALE NTS	WEIGHT (KG) REF.TABLE	REFERENCE INFORMATION B16 & B7M	NO. OF ITEMS -
CODE 320			CAD :C323248	
TITLE	STUD	CARD CODE U 01	DRAWING NO. 3-V-0000-23248	REV 09

DRAWING NO. 3-V-0000-23249

SL. No.	DRAWING No.	COMP. CODE	MATL. SPECN.	S		e		m		øD	MATL. MARK	NET WT. (Kg.)
				MAX.	MIN.	MAX.	MIN.	MAX.	MIN.			
01	3-V-F522-23249/02	96 456 888 0000	ASTM A194 - Gr.7	36.52	35.41	42.16	40.37	22.47	21.16	7/8"-9 UNC -2B	GR.7	0.11
02	3-V-F523-23249/02	96 456 889 0000	ASTM A194 - Gr.7	31.75	30.78	36.65	35.10	19.25	18.03	3/4"-10 UNC -2B	GR.7	0.08
03	3-V-F524-23249/02	96 456 890 0000	ASTM A194 - Gr.7	41.28	40.01	47.65	45.62	25.70	24.28	1"-8 UNC -2B	GR.7	0.17
04	3-V-F525-23249/02	96 456 891 0000	ASTM A194 - Gr.7	50.80	49.23	58.65	56.11	31.78	30.15	1.1/4"-8 UN -2B	GR.7	0.27
05	3-V-F526-23249/02	96 456 892 0000	ASTM A194 - Gr.7	46.02	44.60	53.16	50.85	29.93	27.41	1.1/8"-8 UN -2B	GR.7	0.22
06	3-V-0001-23249	96 465 648 0000	ASTM A194 - Gr.8M	22.22	21.59	25.65	24.61	12.80	11.79	1/2"-13 UNC -2B	GR.8M	0.02
07	3-V-0002-23249	96 465 649 0000	ASTM A194 - Gr.8M	26.97	26.19	31.17	29.85	16.03	14.91	5/8"-11 UNC -2B	GR.8M	0.03
08	3-V-0003-23249	96 465 650 0000	ASTM A194 - Gr.8M	31.75	30.78	36.65	35.10	19.25	18.03	3/4"-10 UNC -2B	GR.8M	0.08
09	3-V-0004-23249	96 465 651 0000	ASTM A194 - Gr.8M	36.52	35.41	42.16	40.37	22.47	21.16	7/8"-9 UNC -2B	GR.8M	0.11
10	3-V-0005-23249	96 465 652 0000	ASTM A194 - Gr.8M	41.28	40.01	47.65	45.62	25.70	24.28	1"-8 UNC -2B	GR.8M	0.17
11	3-V-0006-23249	96 465 653 0000	ASTM A194 - Gr.8M	46.02	44.60	53.16	50.85	29.93	27.41	1.1/8"-8 UN -2B	GR.8M	0.22
12	3-V-0007-23249	96 465 654 0000	ASTM A194 - Gr.8M	50.80	49.23	58.65	56.11	31.78	30.15	1.1/4"-8 UN -2B	GR.8M	0.27
13	3-V-0008-23249	96 465 847 0000	ASTM A194 - Gr.2HM	22.22	21.59	25.65	24.61	12.80	11.79	1/2"-13 UNC -2B	GR.2HM	0.02
14	3-V-0009-23249	96 465 848 0000	ASTM A194 - Gr.2HM	26.97	26.19	31.17	29.85	16.03	14.91	5/8"-11 UNC -2B	GR.2HM	0.03
15	3-V-0010-23249	96 465 849 0000	ASTM A194 - Gr.2HM	31.75	30.78	36.65	35.10	19.25	18.03	3/4"-10 UNC -2B	GR.2HM	0.08
16	3-V-0011-23249	96 465 850 0000	ASTM A194 - Gr.2HM	36.52	35.41	42.16	40.37	22.47	21.16	7/8"-9 UNC -2B	GR.2HM	0.11
17	3-V-0012-23249	96 465 851 0000	ASTM A194 - Gr.2HM	41.28	40.01	47.65	45.62	25.70	24.28	1"-8 UNC -2B	GR.2HM	0.17
18	3-V-0013-23249	96 465 852 0000	ASTM A194 - Gr.2HM	46.02	44.60	53.16	50.85	29.93	27.41	1.1/8"-8 UN -2B	GR.2HM	0.22
19	3-V-0014-23249	96 465 853 0000	ASTM A194 - Gr.2HM	50.80	49.23	58.65	56.11	31.78	30.15	1.1/4"-8 UN -2B	GR.2HM	0.27
20	3-V-0015-23249	96 465 940 0000	ASTM A194 - Gr.8M	55.57	53.8	64.16	61.37	35.0	33.27	1.3/8"-8 UN -2B	GR.8M	0.42

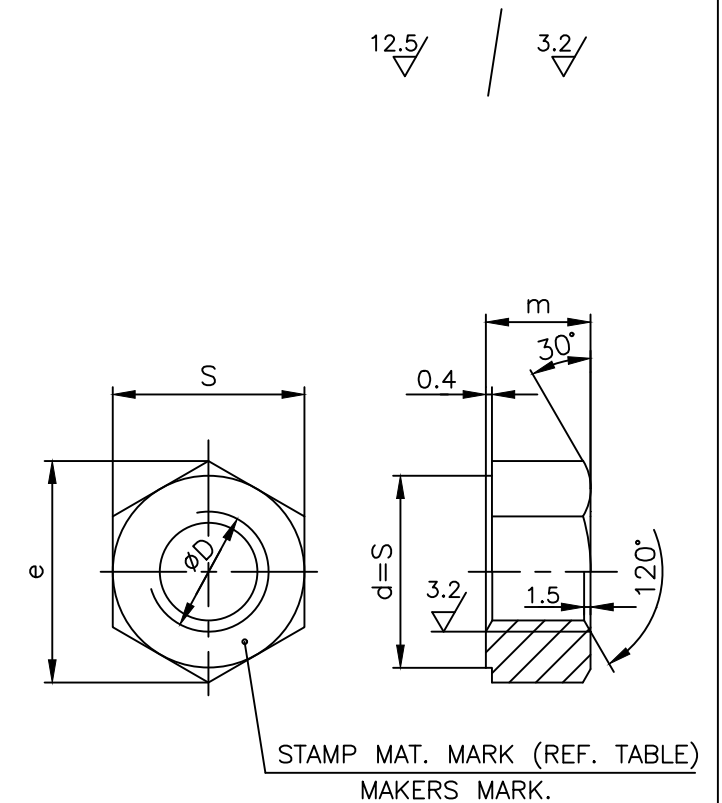

NOTE:

- FOR QUALITY REQUIREMENTS REFER LATEST APPLICABLE QUALITY PROCEDURE.
- SUITABLE OIL PRESERVATIVE SHALL BE APPLIED.

-	-	-	-	-	-	-	-	-	-	-
NO OFF	DESCRIPTION	MATL CODE	MATL SPECN	HEAT TREATMENT	SCRAP SORT	NET WT (kg)	GROSS WT (kg)	DRAWING No	ITEM No	

CAUTION: The information on this document is the property of BHARAT HEAVY ELECTRICALS LTD. It must not be used directly or indirectly in any way detrimental to the interest of the company.

TYPE OF PRODUCT OR NAME OF CUSTOMER/PROJECT

BHARAT HEAVY ELECTRICALS LTD.,
UNIT: HIGH PRESSURE BOILER PLANT.
TIRUCHIRAPALLI-620014.

DRN	M.SRINIVASAN	SIGN	DATE	22.04.96	NO.OF VAR.
CHD	N.DHANAPAL			23.04.96	
APPD	A.VISWANATHAN			23.04.96	

DEPT VL 365-121

SCALE NTS

WEIGHT (KG) REF. TABLE

REFERENCE INFORMATION CAD: F323249

TITLE **HEX NUT**

CARD CODE U 01

DRAWING NO. **3-V-0000-23249**

REV **05**

REV	DATE	ALTERED	R.P.SINGH
05	03.03.21	CHD & APPD	SAMEER & SSK

SL. No. 20 INCLUDED.

3-V-0000-06875
DRAWING NO.

SL.No	DRAWING No.	MATERIAL	MATL. CODE	SIZE	L	WEIGHT IN Kgs.	SIZE/RATING
01	3-V-N073-06875/02	ASTM A193 B7, HT, CERTIFY	964562670000	1/2"-13UNC-2A	68	0.07	2"-150
02	3-V-N081-06875/02		964562680000	1/2"-13UNC-2A	80	0.08	2"-300
03	3-V-N025-06875/02		964562690000	5/8"-11UNC-2A	86	0.13	3"-150
04	3-V-N001-06875/02		964562700000	5/8"-11UNC-2A	94	0.15	4"-150 6"-150
05	3-V-N009-06875/02		964562710000	5/8"-11UNC-2A	105	0.16	8"-150 3",4"-300
06	3-V-N017-06875/02		964562720000	5/8"-11UNC-2A	118	0.18	6"-300
07	3-V-N057-06875/02		964562730000	3/4"-10UNC-2A	112	0.25	10"-150
08	3-V-N041-06875/02		964562740000	3/4"-10UNC-2A	120	0.27	12"-150
09	3-V-N089-06875/02		964562750000	3/4"-10UNC-2A	133	0.30	8"-300
10	3-V-N065-06875/02		964562760000	1"-8UNC-2A	158	0.63	10"-300
11	3-V-N105-06875/02		964562770000	1.1/8"-8UN-2A	180	0.91	12"-300
12	3-V-N106-06875/02		964562780000	1.1/8"-8UN-2A	140	0.71	12"-300
13	3-V-N224-06875/02		964562290000	1"-8UNC-2A	170	0.71	20"-150
14	3-V-1387-06875/02		964564270000	1"-8UNC-2A	135	0.54	16"-150
15	3-V-N204-06875/02		964564280000	3/4"-10UNC-2A	105	0.25	6"-150

SL.No	DRAWING No.	MATERIAL	MATL. CODE	SIZE	L	WEIGHT IN Kgs.	SIZE/RATING
16	3-V-N206-06875/02	ASTM A193 B7, HT, CERTIFY	964564290000	7/8"-9UNC-2A	115	0.35	10"-150
17	3-V-N207-06875/02		964564300000	7/8"-9UNC-2A	125	0.38	12"-150
18	3-V-N212-06875/02		964564560000	7/8"-9UNC-2A	150	0.45	8"-300
19	3-V-F505-06875/01		964566800000	1.1/4"-8UN-2A	215	1.34	8"-600
20	3-V-F506-06875/01		964566810000	1.1/8"-8UN-2A	220	1.41	10"-600
21	3-V-F507-06875/02		964566820000	1.1/4"-8UN-2A	250	1.74	12"-600
22	3-V-N361-06875/01		964567040000	1.1/4"-8UN-2A	150	0.94	24"-150& 16"-300
23	3-V-N437-06875/01		964567430000	1.3/8"-8UN-2A	190	1.44	20"-300
24	3-V-N847-06875		964536630000	1.1/4"-8UN-2A	195	1.23	28"-150
25	3-V-N848-06875		964536640000	1.3/8"-8UN-2A	210	1.58	30"-150
26	3-V-N827-06875		964536650000	1.1/2"-8UN-2A	220	1.96	32"-150
27	3-V-N846-06875/01		964536660000	1.3/4"-8UN-2A	240	2.9	36"-150
28	3-V-NE97-06875		964653420000	1.1/2"-8UN-2A	260	2.32	26"-300
29	3-V-NK44-06875		964659010000	1.5/8"-8UN-2A	270	2.84	28"-300
30	3-V-NK45-06875		964659050000	2"-8UN-2A	275	4.38	28"-600
31	3-V-P788-06875		964659130000	1.3/8"-8UN-2A	235	1.59	14"-600

NOTE:-

FOR QUALITY REQUIREMENTS REFER LATEST APPLICABLE TDC:5:164

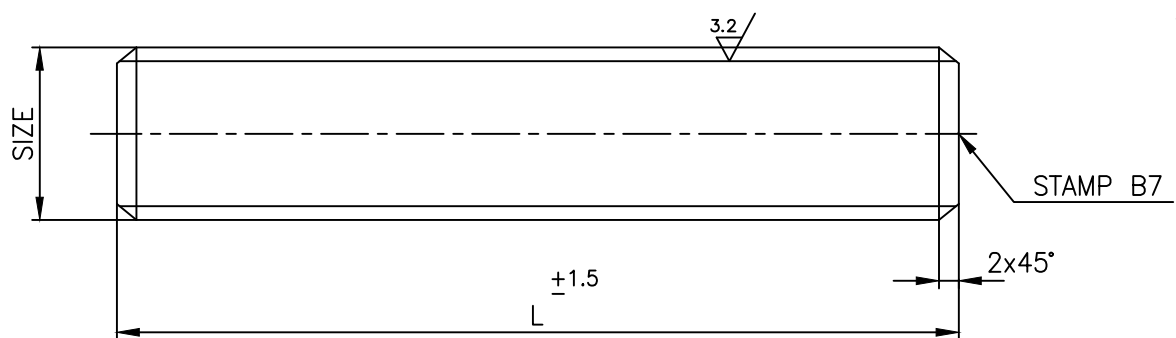

REV	DATE	ALTERED	R.P.SINGH	REV	DATE	ALTERED	R.P.SINGH
14	12.06.19	CHD & APPD	SSK & KRS	13	08.12.18	CHD & APPD	SSK & KRS
SL.No 31 INCLUDED.				SL.No 29 & 30 INCLUDED.			

CAUTION: The information on this document is the property of BHARAT HEAVY ELECTRICALS LTD. It must not be used directly or indirectly in any way detrimental to the interest of the company.

NO OFF	DESCRIPTION	MATL CODE	MATL SPECN	HEAT TREATMENT	SCRAP SORT	NET WT (kg)	GROSS WT (kg)	DRAWING No	ITEM No	
TYPE OF PRODUCT OR NAME OF CUSTOMER/PROJECT										
BHARAT HEAVY ELECTRICALS LTD., UNIT: HIGH PRESSURE BOILER PLANT. TIRUCHIRAPALLI-620014.						DRN	V.BAIRAVAN	SIGN	DATE	NO.OF VAR.
						CHD	S.SATHEESHKUMAR		31.12.09	
						APPD	K.RAJASEKARAN		31.12.09	
DEPT	VL	SCALE		WEIGHT (KG).		REFERENCE INFORMATION				
CODE	320	N T S				CAD .3-V-0000-06875-0-0				
TITLE						CARD CODE	DRAWING NO.		REV	
STUD						U 01	3-V-0000-06875		14	



Product: CARBON & ALLOY STEEL FASTENERS (STUDS, BOLTS & NUTS) FOR VALVES, OIL FIELD EQUIPMENT (OFE) AND OTHER APPLICATIONS

Revision Record: 00: 17.01.90: First issue. Rev: 01:21.06.90 Editorial corrections. Rev 02:21.04.91 TC for studs/bolts added. Rev 03: 04.04.96: Annexure I amended. CI 3.3.3 & 5.3 modified. Rev 04:20.10.96: NDT, Acid pickling added & re-written. Rev 05: 28.04.98: CI 3 modified to include MPI, certificate modified & CI 7.4 deleted. Rev 06:15.06.99: Title, CI 1 to 5 & 7.1 modified. CI 7.2 changed to CI 7.3. CI 7.3 changed to 7.4 and modified. CI 7.2 Galvanizing added. Test certificate sample format modified.
Rev 07: 15/06/2017: TDC: 5:166 for CS & AS Nuts has been merged with this TDC. Totally revised in line with changed requirements and Xylan coating requirements added.
Rev 08: 14/09/2019: CI 1.0, 2.0, 3.0, 4.0, 5.0 modified in line with API 6A 21st Ed 2018 Errata 1 and for better clarity.
Rev.09: 19/02/2021: Latest version of the referred Standards/Specifications indicated throughout TDC; CI.2.0 iid added; CI.4.1 added; Annexure-1 modified;
Rev.10: 25/08/2023: Latest version of the referred Standards/Specifications indicated throughout TDC;

1.0 MATERIAL SPECIFICATIONS:

All the codes, standards, specifications, drawings & procedures, etc., referred in this TDC shall be of latest revision as on the date of Purchase Order, unless specified otherwise.

Studs/Bolts - Alloy Steel	:	ASME SA 193-23 /ASTM A 193-23 Gr B7, B7M & B16.
Nuts - Carbon Steel	:	ASME SA 194-23 /ASTM A 194-23 Gr 2H & 2HM
Alloy Steel	:	ASME SA 194-23 /ASTM A 194-23 Gr 4 & 7
Additional Requirements	:	As listed below (Supplementary to the above material specifications)
Size and Quantity	:	As per Purchase Order (PO) & Applicable Drawing

2.0 GENERAL REQUIREMENTS:

- i. This TDC is applicable for Valves, OFE (API 6A 21st Ed 2018 *Addendum 3* & API 16C 3rd Ed 2021 *Errata 2*) and other applications including NACE MR0175 *Ed. 2021* / ISO 15156 *Ed 2020* Parts 1, 2 & 3. The products shall be manufactured to the relevant requirements specified in the applicable drawings, specifications, PO & this TDC.
- ii. Studs / Bolts / Nuts used for OFE application:
 - a. Studs / Bolts / Nuts shall be qualified and manufactured in accordance with BSL 1 of API 20E. The qualification & requalification records as per API 20E Ed 2017 *Addendum 2 Errata 2* shall be maintained by the Supplier. The supplier shall prepare Manufacturing Process Specification(MPS) to include as a minimum allowable levels for all Studs/Bolts/Nuts manufacturing parameters including process control variables and heat treatment parameters as per API 20E Ed 2017 *Addendum 2 Errata 2* and this TDC.
 - b. Raw material shall be fully wrought. Reduction ratio based on starting material diameter shall be a minimum of 4:1. The steel shall conform to the respective material specifications. Intentional addition of Boron is not allowed. All elements intentionally added to the heat shall be reported in the Test Certificate.
 - c. Furnace calibration shall be in accordance with API 6A 21st Ed 2018 Annex M; SAE AMS 2750 *Rev.G*; or SAE AMS H6875 *Rev.C*. For induction or direct resistant heat treatment, calibration shall be in accordance with manufacturer's written procedure. For forging furnaces, calibration shall be in accordance with manufacturer's written procedure
 - d. Heat lot:
 - Batch furnace: bolting or raw material of a single heat and diameter, heat treated together as a single austenitizing, quenching, tempering, and stress-relieving charge.
 - Continuous furnace: bolting or raw material of a single heat and diameter heat treated without interruption in a continuous charge
- iii. Nuts shall be hot/cold forged or manufactured from hot rolled/cold drawn bars. If made from hexagonal bars, 100% MT is to be done on bars as per ASTM E709-21 to ensure freedom



Product: CARBON & ALLOY STEEL FASTENERS (STUDS, BOLTS & NUTS) FOR VALVES, OIL FIELD EQUIPMENT (OFE) AND OTHER APPLICATIONS

from surface/sub-surface defects.

- iv. Hot rolled & cold drawn bars, if used (for studs/bolts or nuts), shall be machined at least 2 mm (minimum) in radius (i.e. 4 mm in diameter) to remove the seams completely. After machining, at least 10% of the bars shall be tested by MPI as per ASTM E709-21 to ensure freedom from surface/sub-surface defects.
- v. Heat treatment of finished studs/bolts shall be carried as per the material specification requirements for corresponding grades. For heat treatment of finished components, salt bath or controlled atmosphere furnace shall be used. After heat treatment, the threads shall be thoroughly cleaned to remove all deposits. If acid pickling is done for cleaning, it shall be as per Cl. 6 (v) of this TDC.
- vi. Cadmium Plating (Cl 6 (i) of this TDC), Electroplating (Cl 6 (ii) of this TDC) and/or Xylan Coating (Cl 6 (iii) of this TDC) shall be done on the fasteners if specified in Drawing/PO. For all other cases, rust preventive coating (Cl 6 (iv) of this TDC) shall be done.

3.0 CHEMICAL, MECHANICAL PROPERTIES & NDE:

- i. Mill certificate from steel manufacturer for conformance to chemistry heat-wise shall be submitted. Additionally, product analysis shall be done on one sample/heat by the stud/bolt/nut manufacturer. Methods and practices for chemical analysis shall be in accordance with ASTM A 751-21.
- ii. The microstructure and macrostructure shall conform to the requirements of the respective material specifications.
- iii. **Tensile Testing for Studs/Bolts:** One tensile test/heat/size/ HT batch shall be carried out in the finished heat treated condition as per SA / A 193 and shall meet the material specification requirements for corresponding grades.
- iv. **Hardness Testing for Studs/Bolts:**

Hardness testing, including specimen preparation, shall be performed in accordance with ASTM A 370-22 including Annex A3, except that testing shall also be in conformance with ASTM E10-18 or ASTM E18-22.

- a) **For ASME SA 193-23 / ASTM A 193-23 Gr B7 & B16:** Hardness check shall be carried out on finished stud/ bolt as per ASME SA 193-23 / ASTM A 193-23, at least on 10% of the finished studs/bolts.
Gr B7: Hardness: 25 to 34 HRC or 253 to 319 HBW.
Gr B16: Hardness: 25 to 35 HRC or 253 to 321 HBW.
- b) **For ASME SA 193-23 / ASTM A 193-23 Gr B7M:**
Hardness check on 100% of studs/bolts as per SA193.
Gr B7M: Hardness: 94 to 99 HRB or 201 to 235 HBW.

- v. **Mechanical Testing for Nuts:**

- a) **For ASME SA 194-23 / ASTM A 194-23 Gr 2H, Gr 4, & Gr 7:**
Hardness check on finished nuts shall be as per ASME SA 194-23 / ASTM A 194-23 (including quantum of testing).
Gr 4: Hardness: 24 to 35 HRC or 248 to 327 HBW.
Gr 2H & Gr 7: Hardness: 24 to 34 HRC or 248 to 319 HBW.
- b) **For ASME SA 194-23 / ASTM A 194-23 Gr 2HM:**
Hardness check on 100% of finished nuts shall be carried out as per ASME SA 194-23 / ASTM A 194-23.
Gr 2HM: Hardness: 159 to 235 HBW.

	BHEL – Tiruchirappalli - 620014, India. Quality Assurance Department TECHNICAL DELIVERY CONDITIONS	DOC No: TDC:5:164 Rev: 10 Effective Date: 25/08/2023 Page: 3 of 6
	Product: CARBON & ALLOY STEEL FASTENERS (STUDS, BOLTS & NUTS) FOR VALVES, OIL FIELD EQUIPMENT (OFE) AND OTHER APPLICATIONS	

- c) **Proof load test shall be done as per ASME SA 194-23 / ASTM A 194-23 for all grades of nuts** and shall meet the requirements of corresponding grades of the material specification.
- d) After final heat treatment, sample nuts shall be heat treated as per Table 1 and meet the corresponding hardness requirements.

Table 1.

Grade	Temperature (°C)	Soaking Time (Hr)	Cooling	Minimum Hardness (HBW) at room temperature
2H	540	24	Slow Cool	179
2HM	540	24	Slow Cool	159
4, 7	590	24	Slow Cool	201

- e) **Cone Stripping Test:** This test shall be performed as per ASME SA 194-23 / ASTM A 194-23 in case of visible surface discontinuities. On such cases Proof load shall be as per ASME SA 194-23 / ASTM A 194-23.

vi. NDE:

Magnetic particle inspection shall be carried out as per ASTM E709-21 in at least 10% of the finished studs/bolts of all grades. Cracks, linear indications (length \geq 3 times its width) are unacceptable.

4.0 SAMPLING INSPECTION:

All inspection shall be in accordance with relevant drawing or BPS (Boiler Plant Standard), PO, this TDC and ASME SA 193-23 / ASTM A 193-23 for studs/bolts and ASME SA 194-23 / ASTM A 194-23 for nuts. The threads shall be checked with calibrated ring gauges for studs/bolts & plug gauges for nuts in the final heat treated condition for black variety and prior to final plated/coated condition for the cadmium plated/electroplated/ xylan coated items.

Visual, dimensional checks and their acceptance shall be as per applicable drawing and ASME SA 193-23 / ASTM A 193-23 for studs/bolts & ASME SA 194-23 / ASTM A 194-23 for nuts.

4.1 Gauging Requirements for Xylan along with Zinc Coated Fasteners

- i. Studs
 - a. No under sizing is allowed
 - b. Prior to Xylan and Zinc Coating, Class 2A Gauge to be used for inspection
 - c. After coating, No Gauge inspection is required
- ii. Nut
 - a. Under sizing is allowed to maximum of 0.2mm in the internal diameter of threads
 - b. Prior to under sizing, Class 2B Gauge to be used for inspection
 - c. After under sizing, a gauge having an allowance as per Class 2B along with 0.2mm under sizing allowance to be made and inspected thereof
- iii. Assembly of Stud and Nut
 - a. Free run of nut over stud to be ensured
 - b. No play is allowed
 - c. After free run of nut over stud, Xylan coating should not get peeled off.

5.0 MARKING & PACKING:

- i. Punch/emboss each finished component with applicable material grade (B7/ B7M/ B16 for studs/bolts; 2H/2HM/4/7 for nuts) and supplier's emblem. Studs/bolts of grade B7M and nuts of Gr 2HM shall have a line under the grade symbol.
- ii. Punch/emboss serial number also in B7M studs/bolts and Gr 2HM nuts in addition to the above, to correlate with hardness. Protect the threaded ends with plastic end caps. Pack in wooden box/ gunny bag of convenient size for easy handling and transportation. Mark quantity in each box/gunny bag.
- iii. In addition to the above, studs / Bolts / Nuts for OFE applications shall marked with unique heat lot identification and followed by "20E1". Each piece 1 in. nominal diameter and larger shall be

	BHEL – Tiruchirappalli - 620014, India. Quality Assurance Department TECHNICAL DELIVERY CONDITIONS	DOC No: TDC:5:164 Rev: 10 Effective Date: 25/08/2023 Page: 4 of 6
Product: CARBON & ALLOY STEEL FASTENERS (STUDS, BOLTS & NUTS) FOR VALVES, OIL FIELD EQUIPMENT (OFE) AND OTHER APPLICATIONS		

marked. For studs / Bolts / Nuts less than 1 in. nominal diameter, the studs / Bolts / Nuts shall be securely containerized to maintain heat lot identification and traceability. Multiple heat lots shall not be mixed in a single container. Containers used in the processing, storing, and shipping of studs / Bolts / Nuts not individually marked shall be clearly labeled with all marking information required by the relevant material specifications and API 20E Ed 2017 Addendum 2 *Errata 2*.

6.0 SPECIAL REQUIREMENTS:

i. CADMIUM PLATING:

- a) Clean the fasteners to make them free from rust, grease, oil, scale, etc., before plating. When pickling is considered essential, it shall be done as per Cl 6 (v) of this TDC.
- b) Apply Cadmium Plating to the specified thickness on specified areas. Thickness shall be measured on 5% of the PO quantity of fasteners.
- c) After plating, bake the parts at 175°C to 205°C for a minimum period of 3 hours. The elapsed time between plating and baking shall not exceed 8 hours.
- d) Apply a Chromate Conversion coating after plating and baking.

ii. ELECTROPLATING OF ZINC CHROMATE:

- a) Clean the fasteners to make them free from rust, grease, oil, scale, etc., by suitable organic solvents/ hand tool methods before electroplating. Then, pickling shall be done as per Cl 6 (v) of this TDC.
- b) The fasteners shall then be electroplated as per the method and to the minimum coating thickness specified in the applicable drawing. Thickness shall be measured on 5% of the PO quantity of fasteners.
- c) All electroplated parts (regardless of strength level) shall be baked within 2 hours after plating at 375 °F–425 °F (191 °C–218 °C) for 8 hours minimum at temperature

iii. XYLAN COATING:

- a) Clean the fasteners by blast cleaning to Sa2.5 to make them free from rust, grease, oil, scales, etc., before xylan coating.
- b) The fasteners shall then be xylan coated as per the requirements and to the minimum coating thickness specified in the applicable drawing.

c) Tests for Xylan Coating:

The following test shall be carried out on Xylan coated fasteners and results to be reported in the Test certificate (in addition to the Test Certificate for the fastener material and other inspections requirements):

i) Thickness measurement:

Dry film thickness of Xylan coating to be measured using a magnetic induction or Eddy current type electronic gauge and the reading shall meet the drawing/PO requirement for thickness of coating of Xylan 1070. The thickness measurements shall be made in accordance with ASTM D7091-22. Thickness shall be measured on 5% of the PO quantity of fasteners.

ii) Cure Test:

This test method is for ensuring the completeness of cure of Xylan 1070 coating by evaluating the resistance of the cured coating to a solvent known to attack uncured film. The testing method shall be as per Whitford test method 115B (as recommended by the Xylan coating supplier).

Acceptance criteria: No white precipitate or stain shall be available after the test.

iii) Adhesion Test using Cross-hatch and Cello Tape:

Test as per ASTM D3359-23 Method B for measuring Adhesion by Tape Test.

Acceptance Criteria: No loss of adhesion (5B Classification).

iv) Salt Spray Test:

Xylan coated fasteners should pass a minimum requirement of 500 hours of salt spray test as per ASTM B117-19. Certificate of compliance for meeting the salt spray test requirements shall be provided.



Product: CARBON & ALLOY STEEL FASTENERS (STUDS, BOLTS & NUTS) FOR VALVES, OIL FIELD EQUIPMENT (OFE) AND OTHER APPLICATIONS

iv. RUST PREVENTIVE FLUIDS/COATING REQUIREMENTS:

- Clean the fasteners to make them free from rust, grease, oil, scale, etc., by hand tool/ manual cleaning method.
- Apply one coat of rust preventive fluid, of any of the following brands of the suppliers (Table 2), to obtain dry film thickness of 20 microns minimum:

Table 2. Rust Preventive Fluid/Coatings Brands

SI No	Brand/Chemical	Supplier Name and Address
1	BONITA-RPF	M/s Bonita Chemicals, 64, Industrial Estate, Nunhai, Agra-282 006
2	CHAMPION-RPF	M/s Guardian Chemicals, 8, Rajaji Ind st, West Lake Area, Nungambakkam, Madras-600 034
3	ECONOL RPF (non-drying type)	M/s Process Aids, Bangalore
4	TECTYL 506	M/s Plastipeel Chemicals and Plastics (P) Ltd, Thane-400 604
5	TRPF	M/s Sundaram Paints Pvt. Ltd., Thanjavur-613 004
6	TRPF	M/s Solar Paints, Pudukkotai.
7	WICOR-P	M/s Western India Paint and Color Co P. Ltd, Madras-600 017

Use of any other brand/chemical shall be done with the prior approval of BHEL.



v. ACID PICKLING:

- Wherever pickling done, it shall be done using Hydrochloric acid of 5-10% concentration for a period of 5 to 10 minutes at room temperature with suitable inhibitor.
- After pickling thorough rinsing shall be carried out with water to remove acid residues & further DM water rinsing. After thorough rinsing with DM water, the rinsing shall not show any red color (free acidity) when tested with methyl orange indicator.

7.0 CERTIFICATION:

The manufacturer shall provide Test Certificates (TC) duly countersigned by the Authorized Inspecting Authority nominated by BHEL in P.O. (if specified) along with raw material TC from Steel Maker. The applicable versions of the referred Codes, Standards and Specifications shall be reported in the Test Certificates and NDE reports. Manufacturer's TC shall contain the following details as per the sample format attached as Annexure-1 to this TDC:

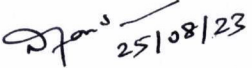
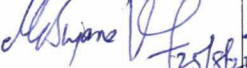
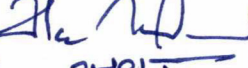
- BHEL PO No & PO Date
- Technical Delivery Condition (TDC) No & its Revision No, Drawing & its revision no
- Melt/Heat No, Serial No (if applicable)
- Raw Material TC Number and Date
- Chemical and Mechanical properties for Studs/Bolts and Nuts including the location and orientation of test specimens
- Heat treatment details (temperature, time, cooling medium, etc.)
- NDE reports with NDE Personnel qualification records, all relevant NDE operating parameters and NDE Results with reference and acceptance criteria
- Type of Surface coating & its coating thickness – Cadmium Plating, Chromate conversion coating, Electroplating, Xylan Coating, Rust preventive coating, etc.
- Test methods and results on Xylan Coating
- Baking details for cadmium plating, electroplating & Xylan coating
- Manufacturers' identification mark
- Certify soundness & confirmation to PO requirements.

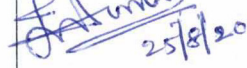
 25/08/23	 25/8/23	 25/8/23	 25/8/23	 25/8/2023
N Nagamuthu Pandian	Mallema Sujana Vinod	Venkateswaru Ala	M Balamurugan	J V V Aruna Kumar
Manager/QA	SM / Valves Engg	Manager/RM QC	SM / Valves/Purchase	AGM / QA&BE
Prepared By	Reviewed By			Approved By



Product: CARBON & ALLOY STEEL FASTENERS (STUDS, BOLTS & NUTS) FOR VALVES, OIL FIELD EQUIPMENT (OFE) AND OTHER APPLICATIONS

Annexure-1. Test certificate for Studs/Bolts & Nuts– Sample format

TC No:	Date:
Customer :	PO No./ Amd :
TDC No./Rev.:	DC No. :
Product :	Drg. No./Rev :
Description : (Spec, dia, pitch, length)	Thread Spec. :
Quantity :	
<u>Requirement</u> :	<u>Records/ Observation</u>
Size of bar - Before machining :	
- After machining :	
Type of furnace used for hardening :	

TDC Clause no.	Raw Material mill TC No: Melt/Heat Number:	TC Date: Reduction Ratio:
2.0 & 3.0	a) Heat Treatment Details:	
	Hardening Temperature: °C; Soaking time: Cooling Medium: Tempering Temperature: °C; Soaking time: Cooling Medium:	
3.0	b) Additional Tempering for Nuts (after final tempering):	
	Temperature: °C; Soaking time: Cooling Medium:	
	a) Product analysis for chemistry	
	Report No & Date:	
	Spec	C Mn P S Si Cr Mo V Ni Others
	Min.	
	Max.	
	Actual	
	b) Tensile test after H & T and final drying (Finished heat treated condition) – For Studs/Bolts	
		UTS (MPa)
Reqd/Spec Value		%Elongation
Test result		%Red in Area
	Spec Value	Test result
	Remarks	
	c) Hardness Test Result (for Studs/Bolts, Nuts):	
	d) Hardness Test Result (for Nuts after 24 hrs of tempering):	
	e) Proof load (kN) for nuts & result	
	f) Result of Cone Stripping test for nuts	
	g) NDE Result for Studs/Bolts:	
4.0	Visual and dimensional checking as per applicable drawing for studs/bolts & nuts:	
5.0	Punching details (identification): End cap for threaded portion:	
6.0	a) Type of coating: Cadmium Plating /Chromate Conversion / Electroplating/ Xylan /Rust preventive coating (Tick applicable coating)	
	Coating thickness/DFT:	
	b) Tests for Xylan Coating	Results
	c) Pickling Acid:	Concentration:
	Drying after pickling. Temperature: °C;	Soaking time:
This is to certify that the above results are correct and the parts meet specification and PO requirements.		
Signature with date Supplier: In-charge of Quality		Signature with date BHEL / Authorized Inspection Agency

Note: Additional Sheets may be attached, if required.



PLANT STANDARD

HPBP TIRUCHIRAPPALLI

BPS 41319

Rev. No. 03

PAGE 1 OF 2

NUTS FOR TEMPERATURE USE

(For medium of temperature upto 425 ° C)

1.0 SCOPE

Covers the requirements of hexagon nuts for use in medium of temperature upto 425 ° C and in the size range M8 to M45x3.

2.0 SPECIFICATION AND REFERENCE STANDARDS

Dimensions and preferred sizes	Fig 1 & Table 1 of this standard	
Tolerance	Product grade	A for nuts with $d \leq M16$ B for nuts with $d > M16$
	Indian Standard	IS 1367 (Part 2)
Thread	Pitch	Table 1 of this standards
	Tolerance	6H
	Indian Standard	IS 4218 (Part 3, 5 & 6)
Material	Steel to ASTM A 194 2H Certified	
Testing	The finished nut shall satisfy the requirements of hardness, proof load and cone proof load, tests as specified in ASTM A194	
General requirements	Nuts shall comply with TDC:5:166 in respect of requirements not covered in this standard, except for cadmium plating	

2.1 Referred standards (Only the relevant parts of current versions are applicable)

IS 1367 (Part 2)	Technical supply conditions for threaded steel fasteners
IS 4218 (Part,3,5 & 6)	ISO metric screw threads
TDC:5:166	Carbon steel nuts for OFE & other applications as per A 194 GR 2H/2HM
ASTM A194	Specification for carbon and alloy steel nuts for bolts for high pressure and high temperature service.

3.0 DESIGNATION

A Grade 'A' hexagon nut to this standard of thread size M8 shall be designated as :

3.1 On Drawings

i) Material Specification column	ASTM A 194 - 2H
ii) Description Column	NUT HEX GR A T425 M8
iii) Drawing Number Column	BPS 41319
iv) Material Code column:	4131900008

Revisions

Brought upto date

Approved

STANDARDS SECTION
CONTRACT ENGINEERING AND CO-ORDINATION
HPBP, TIRUCHIRAPPALLI

Rev. No. 03

Amd. No.

Reaffirmed

Prepared

Issued

Dt of 1st Issue

Dt. JUN 1997

Dt.

Year

STANDARDS

STANDARDS

DEC 1986

3.2 Ordering Description

For placing indents, issuing enquiries and on purchase order, Ordering Description given below shall be followed. (Typical examples)

Hex Nut M8 to BPS : 41319-A-ASTM A194-2H for nuts with $d \leq M16$

Hex Nut M20 to BPS : 41319-B-ASTM A194-2H for nuts with $d > M16$ and $d < M36 \times 3$

Hex Nut M36x3 to BPS: 41319-B-ASTM A194-2H for nuts with $d \geq M36 \times 3$

4.0 ADDITIONAL INFORMATION

4.1 Copies of this standard and TDC:5:166 shall be enclosed along with the purchase order.

Figure 1 DIMENSIONS FOR HEXAGON NUTS

(All dimensions are in millimetres)

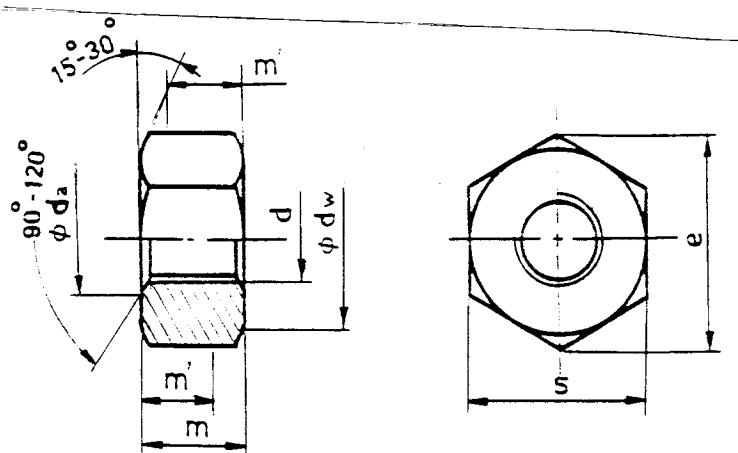

'm' = Effective gauging height

TABLE 1

(All dimensions are in millimetres)

Thread Size d	d _a		d _w	e		m		m'	s		Weight
	Min	Max		Min	Max	Min	Max		Min	Max	
M8	8	8.75	11.6		14.38	8	7.64	6.1	13	12.73	6.0
M10	10	10.80	14.6		17.77	10	9.64	7.7	16	15.73	10.8
M12	12	13.00	16.6		20.03	12	11.57	9.3	18	17.73	16.5
M16	16	17.30	22.5		26.75	17.1	16.40	13.1	24	23.67	33.0
M20	20	21.60	27.7		32.95	20.7	19.40	15.5	30	29.16	64.5
M24	24	25.90	33.2		39.55	24.2	22.90	18.3	36	35.00	110.0
(M27)					45.20	27.6	26.30	21.0	41	40.00	166.0
M30	30	32.40	42.7		50.85	30.7	29.10	23.3	46	45.00	231.0
(M33)					55.37	33	31.40	25.1	50	49.00	299.0
M36x3	36	38.90	51.1		60.79	36.6	35.00	28.6	55	53.80	364.0
(M39x3)					66.44	39	37.40	29.9	60	58.80	485.0
(M45x3)				80.8		45	43.40	34.7	70	68.80	750.0

NOTE :

1. Sizes in brackets are non-preferred.
2. Weights are given in Kg per 1000 numbers only.



PLANT STANDARD

HPBP TIRUCHIRAPPALLI

BPS 41117

Rev. No. 03

PAGE 1 of 3

STUD BOLTS FOR TEMPERATURE USE (For temperatures of medium up to 425°C)

1.0 SCOPE

1.1 Covers the requirements for Stud Bolts for use in medium of temperature 425°C in the size range M12 to M39x3.

2.0 SPECIFICATION AND REFERENCE STANDARDS

Dimensions and Preferred sizes		Fig 1 & Table 1 of this standard
Preferred length-size combination		Table 1 of this standard
Tolerance	Product grade	A
	Indian standard	IS: 1367 (part 2)
Thread	Pitch	Table 1 of this standard
	Tolerance	6g
	Indian standard	IS: 4218 Part 3, IS: 14962 Part 2 & 3
Material		Steel according to ASTM A193-B7 Certified in quenched and tempered condition
Manufacture		Thread rolling up to M24
Mechanical Properties		As specified in ASTM A193 – B7
Marking		All studs shall be stamped B7 on any one side
General requirement		Studs shall comply with TDC:5:164 in respect of requirements not covered in this standard except cadmium plating.

Revisions: Brought up to date

Approved
STANDARDS SECTION
HPBP, TIRUCHIRAPPALLI

Rev. No. 03

Amd. No.

Reaffirmed

Prepared

Issued

Dt of 1st Issue

Dt. 06.04.2022

Dt.

Year:

STANDARDS

STANDARDS

Dec 1986



PLANT STANDARD

HPBP TIRUCHIRAPPALLI

BPS 41117

Rev. No. 03

PAGE 2 of 3

2.1 Referred standards (only the relevant parts of the current versions are applicable)

- | | |
|-----------------------|--|
| IS: 1367 Part 2 | Technical supply conditions for threaded steel fasteners. |
| IS: 1368 | Dimensions for ends of parts with external ISO metric threads. |
| IS: 4218 Part 3 | ISO metric screw threads |
| ASTM-A193 | Specification for alloy steel and stainless bolting material for high temperature service. |
| TDC: 5: 164 | TDC for alloy steel studs to specification ASTM A193 Gr B7/B7m/B16 oil field equipment. |
| S: 14962 (Part 2 & 3) | ISO General Purpose Metric Screw Threads - Tolerances |

3.0 DESIGNATION

A grade - A stud to this standard of thread size M16 and nominal length 90mm shall be designated as:

3.1 On Drawings:

- 1) Material specification column: A 193 B-7
- 2) Description column : STUD BOLT GR A T425 M16x90
- 3) Drawing number column : BPS 41117
- 4) Material code column : 4111716090

3.2 Ordering Description

For placing indents, issuing enquiries and on purchase order, the ordering description given below shall be followed.

Stud M16x90 BPS:41117-A-ASTM-A193-B7

4.0 ADDITIONAL INFORMATION

4.1 Copies of the following standard and TDC: 5: 164 shall be enclosed along with the purchase order.

FIG. 1, DIMENSIONS FOR STUD BOLTS
(All dimensions are in millimetres)

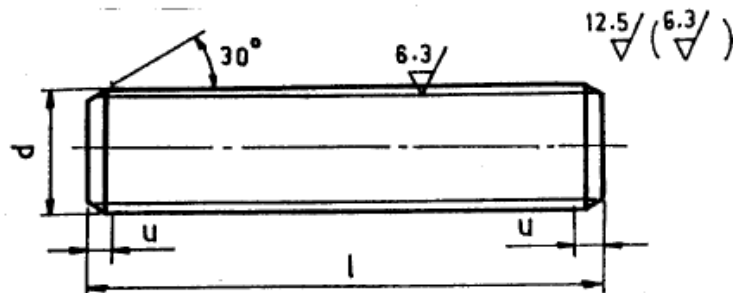

'u' according to IS:1368

TABLE 1 PREFERRED LENGTH - SIZE COMBINATION FOR STUD BOLTS
(All dimensions are in millimetres)

Thread Size d	Nominal Length (l)																	
	60	70	80	90	100	110	120	130	140	150	160	170	180	200	225	240	250	280
	Weights																	
M12		62	70.9															
M16				135.9	151.7		183.3	¹										357.1
M20				221.9			280.9		303									
M24							390.4			496.9			603.4					
(M27)									591.4				770.8					
M30									722.9		832.4							
(M33)													1208.6					
(M39x3)														1875.7				

NOTE:

1. Preferred lengths are in between the stepped bold lines
2. Weights are given in Kg per 1000 numbers only
3. Sizes in brackets are non-preferred.



भारत हेवी इलेक्ट्रिकल्स लिमिटेड

(भारत सरकार का उपक्रम)

इंडस्ट्रियल वाल्वस प्लांट

Bharat Heavy Electricals Limited

(A Govt. of India Undertaking)

Industrial Valves Plant

Quality Assurance Plan for Fasteners*:

NUT, BOLT (INCL EYE BOLT, LIFTING EYE BOLT), STUD

BHE:QAP:FAS:02

Dt:15.03.2019

SN	Stage of inspection	Inspection type		Ref doc	Quantum of check	Format of Record	Agency	
							M	BHEL/TPIA
1	Raw material	Chemical/Mechanical properties		Material test certificate	100%	MTC report	V	V
2	Finished product	Chemical Analysis	Chemical composition	Material specification in drg	one sample per heat	Annex 1 of TDC	P	W
		Mechanical Properties	Tensile strength	Material specification in drg	one sample per heat	Annex 1 of TDC	P	W
			Mechanical testing for nut		10% or 20 nos hardness check at manufacturer end, one sample each type per heat for TPIA or BHEL**			
			Hardness					
		Dimension	As per drawing, Thread with GO/ NO GO Gauge	Material drg/BPS	10% or 20 nos/type.	Inspection report	P	P
		Visual	Free from burrs, physical damages		100%	Annex 1 of TDC	P	P
		MPI	ASTM E709	As per procedure	10% or 20 nos/type.	MPI report	P	W
Marking/Identification	Material grade/supplier name or symbol	As per PO/Drawing/TDC	10%	Annex 1 of TDC	P	W		

Vid
15/03/19
(MKS/WR)

[Signature]
15/03/19
(Gaur Ch)

[Signature]
15/03/19
S.R. Kanng



भारत हैवी इलेक्ट्रिकल्स लिमिटेड

(भारत सरकार का उपक्रम)

इंडस्ट्रियल वाल्वस प्लांट

Bharat Heavy Electricals Limited



(A Govt. of India Undertaking)

Industrial Valves Plant

3	Rust preventive oil		As per TDC:5:164	100%	Annex 1 of TDC	P	W
	Packing	Packed in wooden/cardboard box with layer to layer cushioning material.		10%	Annex 1 of TDC	P	W
	Test certificate	MTC			Annex 1 of TDC	P	V

M-Manufacturer, V-Verification, W-Witness, P-Perform

- * QAP IS PREPARED TO MEET REQUIREMENT OF TDC:5:164 (latest),.PLS REFER IT, IN CASE OF AMBIGUITY ARISES.
- ** TPIA/BHEL MAY INCREASE SAMPLE QTY UP TO 10%.

 Vikas Kumar Sr. Engr / QM Prepared	 Samir Shandilya Sr Mgr/ QM &HSE Reviewed	 S R Kenny AGM/QM, HSE, Engg, TEC & SM) Approved
---	---	--



भारत हेवी इलेक्ट्रिकल्स लिमिटेड
 (भारत सरकार का उपक्रम)
इंडस्ट्रियल वाल्वस प्लांट
Bharat Heavy Electricals Limited
 (A Govt. of India Undertaking)
Industrial Valves Plant

Standard Quality Assurance Plan for Stainless steel fasteners

BHE:SQAP:SS:01

Dt:12.08.2021

SN	Stage of inspection	Inspection type		Ref doc	Quantum of check	Format of Record	Agency	
							M	BHEL/TPIA
1	Raw material	Chemical/Mechanical properties		Material test certificate	100%	MTC report	V	V
2	Finished product	Chemical Analysis	Chemical composition (for both stud and nut)	Material specification in drawing/PO	one sample per heat	Chemical Test Report	P	W
		Mechanical Properties	Tensile strength	Material specification in drawing/PO	one sample per heat	Mechanical Test Report	P	W
			Yield strength/Proof Load (for both stud and nut)		one sample per heat			
			Elongation		one sample per heat			
			Reduction of area		one sample per heat			
			Hardness (for both stud and nut)		10% or 20 nos.			
Dimension	As per drawing, Thread with GO/ NO GO Gauge (for both stud and nut)	Material drg/BPS	10% or 20 nos/type whichever is lower.	Inspection report	P	P		

अमनप्रीत सिंह / Amanpreet Singh
 उप प्रबंधक / Dy. Manager (QM)
 भारत हेवी इलेक्ट्रिकल्स लिमिटेड
 Bharat Heavy Electricals Limited
 (A Govt. of India Undertaking)
 इंडस्ट्रियल वाल्व प्लांट / Industrial Valves Plant
 गोइंदवाल साहिब / Goindwal Sahib (Tarn Taran District)

Manvir Singh
 Sr. Manager (QM)
 BHEL, IVP, Goindwal

(Signature)



भारत हेवी इलेक्ट्रिकल्स लिमिटेड
 (भारत सरकार का उपक्रम)
इंडस्ट्रियल वाल्वस प्लांट
Bharat Heavy Electricals Limited
 (A Govt. of India Undertaking)
Industrial Valves Plant

		Heat Treatment	-----	Material specification in drawing/PO	100%	Heat Treatment Report	P	V
		Visual	Free from burrs, physical damages		100%		P	P
		Marking/Identification	Material grade and supplier name or symbol	As per PO/Drawing/Applicable Standard	10%		P	W
3		Packing	Packed in wooden/cardboard box with layer to layer cushioning material.	As per PO/Drawing/Applicable Standard	10%		P	W

M-Manufacturer, V-Verification, W-Witness, P-Perform

- QAP IS PREPARED TO MEET REQUIREMENT OF ASTM 193 & ASTM 194 (Latest Revisions), PLS REFER IT, IN CASE OF AMBIGUITY ARISES.
- TPIA/BHEL MAY INCREASE SAMPLE QTY UP TO 10%.

 अमनप्रीत सिंह / Amanpreet Singh उप प्रबंधक / Dy. Manager (QM) भारत हेवी इलेक्ट्रिकल्स लिमिटेड Bharat Heavy Electricals Limited (A Govt. of India Undertaking) इंडस्ट्रियल वाल्वस प्लांट / Industrial Valves Plant गोंदवाल साहिब / Goindwal Sahib (Dist. Tarn Taran)	 Manvir Singh Sr. Manager (QM) BHEL, IVP, Goindwal	
Amanpreet Singh Dy. Manager / QM	Manvir Singh Sr Mgr/ QM & BE	S R Kenny AGM/QM & BE
Prepared	Reviewed	Approved