





## **ANNEXURE-1**

### **Pre-Qualification Requirements (PQR)**



1. The firm of Bidder should have in existence since past 3 years as on date of bid opening. Following documents proving the firm is active in past 3 years to be provided.
  - a. Certificate of Incorporation
  - b. Last 3 years "Profit & Loss account/Balance Sheet/ GST returns/Any other acceptable document certified by CA"
2. The Bidder / OEM should have supplied and commissioned offered "Gas Chromatograph" in last 05 years in industry. The self-attested copy of Purchase Order placed on them by customer along with contact details, proof of supply and commissioning report /handing over certificate should be attached.
3. The offered item has completed one year of operation as on date of bid opening. Performance certificate with end user details for the same would be provided by bidder.
4. In case of Agent/Reseller/Traders, offering equipment from OEM, authorization letter from the manufacturer, clearly indicating contact details like name, e-mail & address of manufacturer to be submitted.

हस्ताक्षर एवं दिनांक SIGN & DATE		उत्पाद क्रय विनिर्देश			
		पृष्ठ	3	का	1
		PRODUCT PURCHASE SPECIFICATION			
		Page	1	of	3
SUPERSEDES INVENTORY NO.		<b><u>GAS CHROMATOGRAPH FOR DRINKING WATER</u></b>			
सामग्री सूची संख्या को अधिकृत करता है		<p><b>1. Purpose:</b> Gas Chromatograph (GC) with Digital pressure and flow control for carrier gas, along with Auto leak check facility in the digital measurement through hardware. The chromatograph shall be equipped with, column oven, sample injection unit, carrier gas flow controller, Flame Ionization Detector (FID), Electron Capture Detector (ECD), capillary columns and sample extraction system. The equipment would be used for analysis of organic pollutants (e.g. VOC and Halo VOC Compounds like aromatic hydrocarbons, such as benzene and halogenated hydrocarbons, such as Carbontetrachloride; 1,1Dichloroethelene; 1,2 Dichloroethelene; Tetrachloroethelene; Trichloroethelene; Chloroform) in drinking water samples. For details of compounds to be analyzed by GC and standard limits, please refer “Water Quality Parameters Bangladesh Standards”.</p>			
<b>COPYRIGHT AND CONFIDENTIAL</b> The information on this documents is the property of Bharat Heavy Electrical Limited. It must not be used directly or indirectly in any way detrimental to the interest of the company		<p><b>2. Specifications of Equipment:</b></p> <p><b>2.1 Column Oven</b></p> <p>Temp range : Ambient to 400 °C or better.</p> <p>Oven capacity : 14 ltrs Approx.</p> <p>Temp Stability : <math>\pm 0.1^{\circ}\text{C}</math></p> <p>Cooling rate : 250 °C to 50 °C in 6 mins or less.</p> <p><b>2.2 Sample injection unit:</b></p> <p>Temp. range : upto 400 °C or better</p> <p>Heating settings : 1°C steps</p> <p>Type : Capillary columns, split/split less</p> <p><b>2.3 Carrier Gas flow controller with digital readout.</b></p> <p>Range : 0.1 - 100 ml/min</p> <p>Steps : 3 or more</p> <p><b>2.4 Detectors:</b></p> <p><b>Flame Ionization Detector (FID)</b> : 400 °C or better</p> <p><b>Electron Capture Detector (ECD).</b> : 350 °C or better</p> <p><b>2.5 Auto Headspace Sampler with Automatic injection.</b></p> <p><b>2.6 Chromatography Software:</b> Microsoft Windows based chromatography software for Quantitative &amp; Qualitative end results.</p>			
	<b>स्वत्वाधिकार एवं गोपनीय</b> इस प्रलेख में दी गयी सूचना भारत हेवी इलेक्ट्रिकल्स की सम्पत्ति है। इसका प्रत्यक्ष एवं अप्रत्यक्ष रूप से किसी भी तरह प्रयोग, जो कि कम्पनी के हित में होस्कारका हो न किया जाये।				
र एवं दिनांक & DATE					

हस्ताक्षर एवं दिनांक SIGN & DATE		उत्पाद क्रय विनिर्देश			
		ANNEXURE-2			
हस्ताक्षर एवं दिनांक SIGN & DATE		पृष्ठ	3	का	2
		Page	2	of	3
SUPERSEDES INVENTORY NO.		<p><b>2.7 Computer &amp; Printer</b> : Latest Windows based compatible computer (Minimum Configuration- i5 processor, 4 GB RAM, 500 GB SSD), 19" Monitor, UPS for computer, Mouse Pad, Key Board, B/W laser Printer with speed 25 PPM or better.</p>			
सामग्री सूची सख्तया को अधिकतमिमत करता है		<p><b>2.8 Voltage Stabilizer:</b> Min 5 KVA or better as per system requirement.</p>			
<b>COPYRIGHT AND CONFIDENTIAL</b> <small>The information on this documents is the property of Bharat Heavy Electrical Limited. It must not be used directly or indirectly in any way detrimental to the interest of the company</small>		<p><b>2.9 Gas Purification Panel for Three Gases with Tubing's and Complete Fitment (1 No.)</b></p>			
		<p><b>2.10 Required Gas Cylinders of 99.9% purity &amp; 47 Ltr capacity with Double Stage Regulators for H<sub>2</sub>, N<sub>2</sub> and Zero Air (1 Set)-</b> Filling of gas cylinders as per specification requirement would be done at the time of I&amp;C of equipment.</p>			
		<p><b>2.11 Bracket for Cylinder Holding</b> : 6 Nos.</p>			
		<p><b>2.12 Reference Standards:</b> GC reference standards (Min. 1 ml each) should be supplied for VOC &amp; Halo VOC Compounds (Benzene; Carbontetrachloride; 1,1Dichloroethelene; 1,2 Dichloroethelene; Tetrachloroethelene; Trichloroethelene; Chloroform) All the Standards should be supplied at the time of Installation &amp; Commissioning.</p>			
		<p><b>2.13 Installation Kit:</b> Installation kit including, Syringe, SS Tubing, Nuts, Ferrules, Spanners Silicone Rubber Septum (100 Pcs) should be supplied as per requirement.</p>			
		<p><b>2.14 Silicon Rubber Septum (100 pcs/pkt)</b> : 1 Pkt.</p>			
		<p><b>2.15 Columns:</b> Suitable Capillary Columns (Min. length of 50 Meter or more) as per application to be provided.</p>			
		<p><b>2.16</b> The system should be complete with all accessories to install and demonstrate the equipment at site.</p>			
		<p><b>2.17</b> Any accessories/consumables/regents/standards/chemicals not specified but required for installation, commissioning and operation of equipment would be part of package and same should be supplied by bidder against BHEL enquiry.</p>			
		<p><b>Seaworthy packaging to be done for shipping of the equipment to project site.</b> <b>Detailed printed Catalogue along with technical data sheet must be provided with the offer submitted along with undertaking from the Vendor to supply the genuine make equipment.</b></p>			
हस्ताक्षर एवं दिनांक SIGN & DATE					

fnukad ,oa gl.rk(kj SIGN & DATE		<b>उत्पाद क्रय विनिर्देश</b>			ANNEXURE-2			
SUPERSEDES INVENTORY NO.		<b>PRODUCT PURCHASE SPECIFICATION</b>			पृष्ठ	3	का	3
I सामग्री सूची सख्या को अधिकृतित करता है					Page	3	of	3
<b>COPYRIGHT AND CONFIDENTIAL</b> <small>The information on this documents is the property of Bharat Heavy Electrical Limited. It must not be used directly or indirectly in any way detrimental to the interest of the company</small>		<p><b>3.0 General Terms &amp; Conditions</b></p> <p><b>3.1 Document:</b> Hard copy of O&amp;M Manual in English language giving complete technical information for operation and maintenance of the equipment shall be supplied.</p> <p><b>3.2 Installation and Commissioning:</b> The supplier shall provide installation, commissioning and demonstration of supplied items at 2x660MW Maitree Project Site, Bangladesh.</p> <p><b>3.3 Guarantee:</b> The equipment shall be guaranteed/warranted for satisfactory performance for a period of <b>24 months</b> from the date of installation/commissioning.  <b><i>Failing to comply to the Guarantee/ Warranty clause, the offer will be rejected Straightaway.</i></b></p> <p><b>3.4 Packing &amp; Dispatch:</b> The equipment / accessories shall be packed in a suitable water Proof/ vibration proof sea worthy packing box capable of bearing water, air and road transit hazards. Packing box shall be properly identified and marked with BHEL's (India) Purchase Order Number. Also, "PCRI HWR" should be written in bold letters on all four sides of the packing box.</p>						
	<b>स्वत्वाधिकार एवं गोपनीय</b> <small>इस पत्र में दी गयी सूचना भारत हेवी इलेक्ट्रिकल्स की सम्पत्ति है। इसका प्रत्यक्ष एवं अप्रत्यक्ष रूप से किसी भी तरह प्रयोग, जो कि कम्पनी के हित में दुर्विचारक हो न किया जाये।</small>							
<b>हस्ताक्षर एवं दिना</b> <b>SIGN &amp; DATE</b>								

हस्ताक्षर एवं दिनांक SIGN & DATE		उत्पाद क्रय विनिर्देश			
		पृष्ठ	3	का	1
SUPERSEDES INVENTORY NO.		PRODUCT PURCHASE SPECIFICATION			
सामग्री सूची संख्या को अधिकृतित करता है		<p align="center"><b><u>GAS CHROMATOGRAPH FOR NATURAL GAS ANALYSIS</u></b></p> <p><b>1. Purpose:</b> Gas Chromatograph with FID, TCD detectors for Natural Gas Analysis for N<sub>2</sub>, CO, CO<sub>2</sub>, H<sub>2</sub>S, C<sub>1</sub>-C<sub>6</sub> in Chemical Laboratory at Thermal Power Station.</p> <p><b>2. Specifications of Equipment:</b></p> <p><b>2.1 Column Oven</b>  Temp range : Ambient to 400 °C or better.  Oven Capacity : 13 liters or more.  Temp Stability : ± 0.1°C  Cooling rate : 250 °C to 50 °C in 6 minutes or less.</p> <p><b>2.2 Sample injection unit:</b>  Temp. range : Upto 400 °C or better  Heating settings : 1 °C steps  Type : Dual packed/ Single packed, Split / Split less</p> <p><b>2.3 Carrier Gas flow controller with digital readout.</b></p> <p><b>2.4 Detectors:</b>  <b>Flame Ionization Detector (FID)</b> : 400 °C or better  <b>Thermal Conductivity Detector (TCD).</b> : 400 °C or better</p> <p><b>2.5 Chromatography Software</b> : Microsoft Windows Based chromatography software for Quantitative &amp; Qualitative end results.</p> <p><b>2.6 Computer &amp; Printer</b> : Latest Windows based compatible computer (Minimum Configuration- i5 processor, 4 GB RAM, 500 GB SSD), 19" Monitor, UPS for computer, Mouse Pad, Key Board, B/W laser Printer with speed 25 PPM or better.</p> <p><b>2.7 Voltage Stabilizer</b> : Min 5 KVA or better as per system requirement.</p> <p><b>2.8 Gas Purification Panel for Three Gases with Tubing's and Complete Fitment (1 No.)</b></p> <p><b>2.9 Required Gas Cylinders of 99.9% purity &amp; 47 Ltr capacity with Double Stage Regulators for H<sub>2</sub>, He and Zero Air (1 Set)-</b> Filling of gas cylinders as per specification requirement would be done at the time of I&amp;C of equipment.</p>			
र एवं दिनांक & DATE					
<p align="center"><b>स्वत्वाधिकार एवं गोपनीय</b></p> <p>इस प्रलेख में दी गयी सूचना भारत हेतु इलेक्ट्रिकल्स की सम्पत्ति है। इसका प्रत्यक्ष एवं अप्रत्यक्ष रूप से किसी भी तरह प्रयोग, जो कि कम्पनी के हित में हो, अधिकारका हो न किया जाये।</p>		<p align="center"><b>COPYRIGHT AND CONFIDENTIAL</b></p> <p>The information on this documents is the property of Bharat Heavy Electrical Limited. It must not be used directly or indirectly in any way detrimental to the interest of the company</p>			

हस्ताक्षर एवं दिनांक SIGN & DATE		उत्पाद क्रय विनिर्देश			
		पृष्ठ	3	का	2
हस्ताक्षर एवं दिनांक SIGN & DATE		PRODUCT PURCHASE SPECIFICATION			
हस्ताक्षर एवं दिनांक SIGN & DATE		Page	2	of	3
SUPERSEDES INVENTORY NO.		<p><b>2.10 Bracket for Cylinder Holding</b> : 6 Nos.</p> <p><b>2.11 Calibration Gas:</b> Gas cylinders (3 Lit. or More capacity) containing N<sub>2</sub>, Ethane, Propane, iso-Butane, n- Butane, iso- Pentane, n- Pentane, n-Hexane, Methane, with Helium as a balance quantity.</p> <p><b>2.12 Installation Kit:</b> Installation kit including, Syringe, SS Tubing, Nuts, Ferrules, Spanners. Silicone Rubber Septum (100 Pcs) should be supplied as per requirement.</p> <p><b>2.13 Columns:</b> Suitable Packed columns as per system application to be provided.</p> <p><b>2.14</b> The system should be supplied with NGA (Natural Gas Analysis) Module, Inbuilt Methanizer, Auto Gas Sampling Valve and complete with all accessories to install and demonstrate the equipment at site.</p> <p><b>2.15</b> Any accessories/consumables/regents/standards/chemicals not specified but required for Installation, commissioning and operation of equipment would be part of package which is offered against enquiry.</p> <p><i>Seaworthy packaging to be done for shipping of the equipment to project site.</i>  <i>Detailed printed Catalogue along with technical data sheet must be provided with the offer submitted along with undertaking from the Vendor to supply the genuine make equipment.</i></p>			
सामग्री सूची संख्या को अधिकारित करता है					
COPYRIGHT AND CONFIDENTIAL The information on this documents is the property of Bharat Heavy Electrical Limited. It must not be used directly or indirectly in any way detrimental to the interest of the company					
स्वत्वाधिकार एवं गोपनीय इस प्रलेख में दी गयी सूचना भारत हेवी इलेक्ट्रिकल्स की सम्पत्ति है इसका प्रत्यक्ष एवं अप्रत्यक्ष रूप से किसी भी तरह प्रयोग, जो कि कम्पनी के हित में हानिकारक हो न किया जाये।					
हस्ताक्षर एवं दिनांक SIGN & DATE					

fnuakad .oa gl-rrk(kj SIGN & DATE		<b>उत्पाद क्रय विनिर्देश</b>		<b>ANNEXURE-3</b>	
SUPERSEDES INVENTORY NO.		<b>PRODUCT PURCHASE SPECIFICATION</b>		पृष्ठ	3
I सामग्री सूची संख्या को अभिक्रमिति करता है				Page	3
<b>COPYRIGHT AND CONFIDENTIAL</b> <small>The information on this documents is the property of Bharat Heavy Electrical Limited. It must not be used directly or indirectly in any way detrimental to the interest of the company</small>		<p><b>3.0 General Terms &amp; Conditions:</b></p> <p><b>3.1 Document:</b> Hard copy of O&amp;M Manual in English language giving complete technical information for operation and maintenance of the equipment shall be supplied.</p> <p><b>3.2 Installation and Commissioning:</b> The supplier shall provide installation, commissioning and demonstration of supplied items at 2x660MW Maitree Project Site, Bangladesh.</p> <p><b>3.3 Guarantee:</b> The equipment shall be guaranteed/warranted for satisfactory performance for a period of <b>24 months</b> from the date of installation/commissioning.</p> <p><i>Failing to comply to the Guarantee/ Warranty clause, the offer will be rejected Straightaway.</i></p> <p><b>3.4 Packing &amp; Dispatch:</b> The equipment / accessories shall be packed in a suitable water Proof/ vibration proof sea worthy packing box capable of bearing water, air and road transit hazards. Packing box shall be properly identified and marked with BHEL's (India) Purchase Order Number. Also, "PCRI HWR" should be written in bold letters on all four sides of the packing box.</p>		of	3
	<p style="text-align: center;"><b>स्वाधिकार एवं गोपनीय</b></p> <p>इस परलेख में दी गयी सूचना भारत हेवी इलेक्ट्रिकल्स की सम्पत्ति है। इसका प्रत्यक्ष एवं अप्रत्यक्ष रूप से किसी भी तरह प्रयोग, जो कि कम्पनी के हित में हितकारक हो न किया जाये।</p>				
हस्ताक्षर एवं दिना SIGN & DATE					

BHARAT HEAVY ELECTRICALS LIMITED

## INSTRUCTIONS FOR SEA-WORTHY PACKING FOR BOIs

FOR

2X660 MW MAITREE SUPER THERMAL POWER PROJECT,  
BANGLADESH

BHEL DOCUMENT NO. : TGE-3646

REV-01 DATE : 29.03.2018

BHARAT HEAVY ELECTRICALS LTD  
UNIT : HEEP, RANIPUR, HARIDWARELECTRICAL MACHINES ENGINEERING  
BHEL HARDWAR

*Gopal Chauhan*  
29.03.18  
PREPARED BY  
GOPAL CHAUHAN  
Sr. ENGR./EME

*Manju Azad*  
29/3/18  
CHECKED BY  
MANJU AZAD  
MGR./EME

*R.L. Vyas*  
29/3/18  
APPROVED BY  
R.L.VYAS  
AGM/EME

**INSTRUCTIONS FOR SEA-WORTHY PACKING FOR BOIs**  
**FOR 2x660MW MAITREE PROJECT**

**1. GENERAL**

The standard covers guide lines for making Sea- worthy standard packing boxes to be used for transportation for export orders. Vendors shall be responsible for packing and shall meet the minimum requirements specified herein.

**2. SCOPE**

The procedure specifies minimum guidelines to be complied with for packing of Components /Assemblies/Equipments. This specification shall be suitable for different handling operations and the adverse conditions during transportation and during indoor/outdoor storage for period of minimum two years.

**3. WOOD SPECIFICATION FOR PACKING**

The wood used for packing shall conform to specification ISPM NO. 15. (International Standards for Phytosanitary Measures)

**4. REQUIREMENTS FOR PACKING CASE**

- 4.1. All equipment and materials shall be suitably coated wrapped, or covered and boxed or crated for export shipment so as to prevent damage during handling and storage at the Site. Cardboard containers (if any) shall be enclosed in a solid wooden container to avoid damage during transit.
- 4.2. Equipment and process materials shall be packed and semi knocked down, to the extent possible, to facilitate handling and storage and to protect bearings and other machine surfaces from oxidation. Each container box, crate or bundle shall be reinforced with steel strapping, in such a manner that breaking of one strap will not cause complete failure of the packaging. The packing shall be of best standard to withstand rough handling and to provide suitable protection from tropical weather while in transit and while awaiting erection at the site.
- 4.3. Waterproof paper and felt linings shall overlap at seams at least 15mm and the seams shall be secured together.
- 4.4. Equipment and materials in wooden cases or crates shall be properly cushioned to withstand the abuse of handling, transportation and storage. Packing shall include preservatives suitable for tropical conditions. All machine surfaces and bearings shall be coated with oxidation preventative compounds. All parts subject to damage when in contact with water shall be coated with suitable grease and wrapped in heavy asphalt or tar impregnated paper.
- 4.5. Fumigation of boxes including plywood/spacers shall be carried out as per ISPM 15 to make it pest free. All wood packing in each consignment shall be free from bark and all visible signs and fungal attack at the time of shipment.
- 4.6. Components sub-assemblies and assemblies sensitive to climatic conditions shall be packed seal tight. All the openings of the sensitive components, sub-assemblies and assemblies shall be blanketed to prevent the ingress of dust and moisture. The components sub-assemblies and

assemblies shall be completely covered with 2 layers of polyethylene sheet. Polyethylene sheet to be used shall be UV stabilized. All sharp corners and edges are to be protected by rubber mats to prevent damage the polyethylene sheet. Top surface of the case shall be free from dents to prevent rain water pockets.

- 4.7. All delicate electrical/ instrument components, assembled or loose, likely to be damaged e.g. Gauges, Instruments etc. are to be wrapped in waxed paper or polyethylene air bubble film along with silica gel pack/VCI powder or tablet.
- 4.8. All delicate electrical/ instrument components if sent loose shall be placed in carton, filled with small chips of Expanded Polystyrene (Thermocol), Wood Wool etc.
- 4.9. For equipment like control panels etc. suitable cushioning material like rubber sheet shall be provided on their bottom support (ref fig 1). The gap between the panel and the packing box shall be filled with Thermocol, (Non - hygroscopic material). Distance between adjacent packing of thermocol shall not be more than 500 mm (ref fig 2).

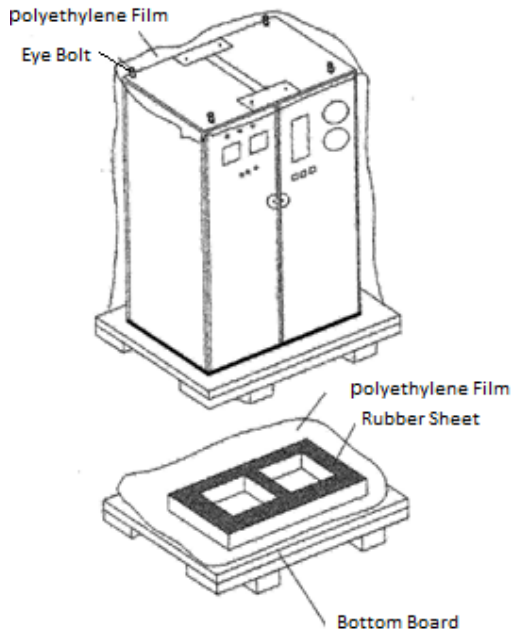

Fig-1

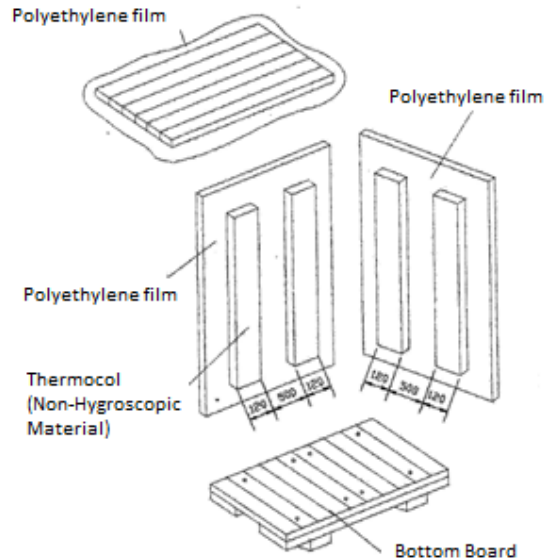
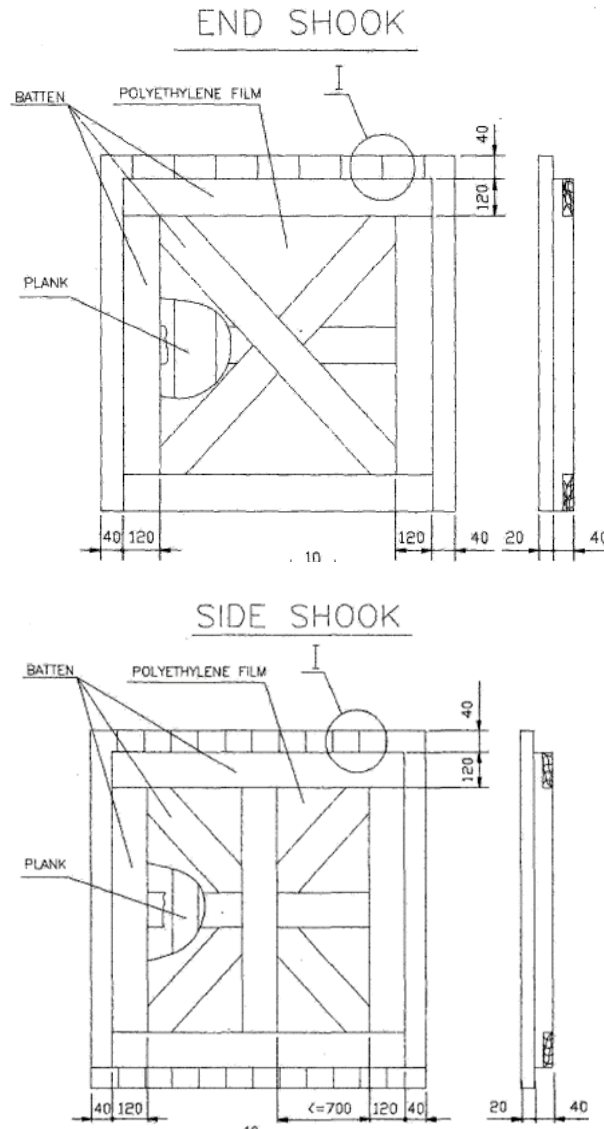

Fig-2

- 4.10. The four sides, shall be lined, from inside with multi-layered polyethylene sheet of at least 120 GSM and tacked at suitable places.

Whenever specified in addition to the polyethylene sheet the top cover will have a layer of bitumen felt over the cover. This should project about 100 - 250 mm on all sides. shall be provided between frame and planks of the end and side shook as shown in Fig. (For reference only.)



\* DIMENSIONS SHOWN IN ABOVE FIGGURE ARE INDICATIVE ONLY.

It is preferable to have a single piece of the above multi-layered polyethylene sheet fixed on the four sides. In case jointing is unavoidable, it should be done by overlapping of approximately 100 mm.

Place the Components/cartons with corrosion inhibitors duly applied wherever necessary for place suitably, thin muslin cloths bags containing minimum 100 grams (approx.) of activated Blue Silica Gel as per BS 3482-1991 or equivalent with standard particle size of 3 to 6 mesh (5.6 to 2.8mm), wherever necessary. Alternatively, Tablet/ VCI Powder as per IEC 68-2-30-1980 or equivalent may be used. Approximately 7 m<sup>3</sup> VCI paper is necessary for 1 m<sup>3</sup> of packed item. VCI Paper shall not be used for components made of aluminum, aluminum alloys, Zinc, Copper, Brass, cadmium & silver. VCI powder is sprinkled inside the piping components ends and shall be protected with end cover.

All packages shall be covered on all sides, with suitable GI sheets preferably single length & width.

- 4.11. Cover the whole equipment with polyethylene sheet of at least 120 GSM, on all sides preferably by a single piece.
- 4.12. Silica gel is used for this purpose to protect the contents over sufficiently long time from corrosion. At the time of use, silica gel should be so dried that its colour becomes dark blue. These shall be filled in small cotton bags. Before sealing the equipment, the silica gel bags should be kept inside the polyethylene film cover at different locations. The quantity of silica gel should not be less than 2.0 Kg per m<sup>3</sup> volume of the packing box.
- 4.13. Each case shall contain a packing list showing the detailed contents of the package. When any technical documents are supplied along with the shipment of materials no single package shall contain more than one set of such documents. Shipping papers shall clearly indicate in which packages the technical documents are contained.
- 4.14. The case number shall be written in the form of a fraction, the numerator of which is the serial number of the case and the denominator the total number of case in which a complete unit of equipment is packed.
- 4.15. Wherever necessary besides usual Inscriptions the cases shall bear special indication such as "Top", "Do not turn over", "Care", "Keep dry", etc., as well as indication of the center of gravity (with red vertical lines) and places for attaching slings (with chain marks). For all fragile equipment, unit should take special care to pack and label with additional markings such as "FRAGILE, HANDLE WITH CARE", "LIFTING POINTS", "THIS WAY UP", "DO NOT STACK" etc. to protect them from damage in transit.
- 4.16. **Completeness of Contents of each packing case:**  
Concerned CQA/Unit QC/Third Party Inspection Agency shall verify the completeness of contents of each package w.r.t. packing list both in terms of quality and quantity before authorising dispatch of the consignment.

Packing commensurate with international standards and accepted norms will be ensured by CQA/ Unit QC/Third Party Inspection Agency. Packing has to be sea-worthy and secure. As far as possible, the packing has to be rectangular in shape for optimum space utilization in the ship and economize on shipping costs. Projections on packages are prohibited.

The packing list has to be checked and certified by the Inspection agency with due signatures. All packages shall be covered on all sides, with suitable GI sheets preferably single length & width.

No loose items Gunny bag packing are allowed for shipment. Proper pallets and crates are to be used for packing of Oil drums and Structures.

- 4.17. **Provision of Inspection Windows on Packages:**  
Vendors should provide inspection window of size 6" x 4" (glass perplez) for customs examination for all packages (above 1.5 x 1.5 x 1.5 cum) involving panels of any kind. Care would be taken to ensure that all packages are properly sealed to avoid ingress of moisture, rodents etc. Packing slip folders shall be attached in each box.

**4.18. Provision of Humidity Indicator:**

- i. Humidity indicator must be provided in each packing boxes. Humidity indicator shall be placed behind inspection window or as far as practicable from the nearest unit of desiccant.
- ii. Use a three-spot paper card type 1x4 inches in size to show humidity with instruction as indicated in figure below. The spots indicate relative humidity of 50 percent, 40 percent and 30 percent, top to bottom, by changing color from blue to pink.

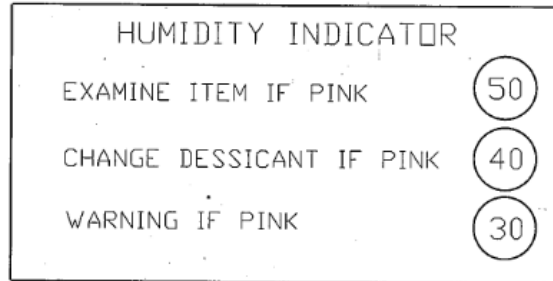
**4.19. Marking for Safe Handling:**

To ensure safe handling, packing case shall be marked to show the following:

- i. Upright position.
- ii. Sling position and Centre of Gravity position.
- iii. Storage category.
- iv. Fragile components (to be marked properly with a clear warning for safe handling).

**4.20. Other Marking on Packing Case**

- a) Address of Consignee
- b) Purchase order No.
- c) Description of item or Title of Packing list
- d) Package number strictly as given in the Indent
- e) Net Weight
- f) Gross Weight
- g) Dimensions of the Box

**4.21. Shipping Documentation including those covered by customs requirements:**

- i. Packing List (O&M manual to be listed in packing list, if sent along with consignment).
- ii. Fumigation certificate for wooden boxes



PCRI-BOI DEPARTMENT  
BHARAT HEAVY ELECTRICALS LIMITED  
HEEP: HARDWAR-249 403 (Uttarakhand)  
TEL: +91 1334 28 1941

SHIPPING INSTRUCTIONS FOR  
2 x 660 MW MAITREE SUPER  
THERMAL POWER PROJECT,  
BANGLADESH

### ANNEXURE-VII

These are Standard Shipping and packing Instructions for 2X660MW Maitree Project and should be followed for all the material which is to be dispatched for Maitree Project

Sl. No.	Detail / Description / Instruction	Action By.
1.	<p><b><u>Final Customer's Name and Address:</u></b></p> <p>Managing Director, Bangladesh-India Friendship Power Company (Pvt.) Limited (BIFPCL), Level-17, Borak Unique Height, 117, Kazi Nazrul Islam Avenue, Eskaton Garden, Dhaka-1217, Bangladesh Contact Details: 8823941805</p>	For Information
2.	<p><b><u>Final Destination Address:</u></b></p> <p>Site In charge, 2x660 MW Maitree Super Thermal Power Project, PO-Kalekkharber, Union-Rajnagar, Upajila-Rampal, Dist: Bagerhat -93 4 3, Bangladesh Contact No.: +8801678582823</p>	Suppliers to ensure proper marking of Consignee address on the boxes so as to Identify the final destination clearly.
3.	<p><b><u>Delivery Address:</u></b></p> <p>Items shall be dispatched to the address as per Sl. No. 4.0 of this document.</p>	All Suppliers
4.	<p><b>All materials to be dispatched under intimation to:</b></p> <p><b><u>For Indigenous Vendors :</u></b></p> <p><b>1. For Shipments through Chennai :</b></p> <p>Consignment shall be sent to the following address:</p> <p><b>Mr. Harsha Trivedi, Engineer/Docks Bharat Heavy Electricals Ltd Near Marshalling Yard, Chennai Port trust Chennai 600 001 Ph. No 044 25362247/25360446 -Mob 08680850932 E-mail: trivedi@bhel.in</b></p> <p>The couriers /correspondence shall be sent to the following address:</p> <p>Shri S S RAJAN AGM/MS, Bharat Heavy Electricals Ltd Regional Operations Division, EVR Building 6th floor No 690 (Old No 474) Anna Salai, Nandanam Chennai 600 035 Mob 09840997089 E-mail <a href="mailto:ssrajan@bhel.in">ssrajan@bhel.in</a></p>	All Suppliers



PCRI-BOI DEPARTMENT  
BHARAT HEAVY ELECTRICALS LIMITED  
HEEP: HARDWAR-249 403 (Uttarakhand)  
TEL: +91 1334 28 1941

SHIPPING INSTRUCTIONS FOR  
2 x 660 MW MAITREE SUPER  
THERMAL POWER PROJECT,  
BANGLADESH

### ANNEXURE-VII

	<p><b>2. For Shipments through Kolkata / Haldia / Kolaghat:</b></p> <p>Address of Ware house shall be intimated to vendors before dispatch:</p> <p>The couriers /correspondence shall be sent to the following address:</p> <p>Mr. Abhijit Chowdhury, Sr. Engineer Bharat Heavy Electricals Ltd Regional Operations Division DJ 9/1 SECTOR II, Saltlake, Karunamoyee West Bengal 700091 Mob- 9830441607 E-mail: <a href="mailto:abhijit@bhel.in">abhijit@bhel.in</a></p> <p><b><u>For Foreign Vendors :</u></b></p> <p>Consignment shall be sent to the following address:</p> <p><b>Dhaka Airport, Bangladesh</b></p>	
5.	<p><b><u>Shipping Marks:</u></b></p> <p>Each package / BOX / shipping unit shall be clearly marked or stenciled on at least two sides as follows:</p> <p><b><i>"BANGLADESH-INDIA FRIENDSHIP POWER COMPANY (Pvt.) LIMITED, 2X660 MW MAITREE SUPER THERMAL POWER PROJECT, BANGLADESH" EPC Contractor -Bharat Heavy Electricals Limited, India"</i></b></p> <p>In addition, package / BOX / shipping unit shall have the symbol painted in red on at least two sides of the package, covering one fourth of the area of the side.</p>	All Suppliers
6.	<p><b><u>"Bill To" Address:</u></b></p> <p>PCRI-BOI Department Heavy Electrical Equipment Plant (HEEP) BHEL Haridwar (Uttarakhand) Pin 249403</p>	All Suppliers
7.	<p><b><u>Note:</u></b></p> <p>1. <b><u>"Bill To"</u></b> address should be strictly as per Sl. No. 6 of this document. 2. <b><u>"Delivery"</u></b> address should be strictly as per Sl. No. 3 &amp; 4 of this document. 3. <b><u>"Final Destination"</u></b> address to be properly marked on the boxes as per Sl. No. 2 of this document.</p>	All Suppliers
8.	<p>Packing (tare) shall be part of the Equipment cost and shall not be subject to return. The packing should ensure integrity and cohesiveness of each delivery batch of Equipment during transportation. In case of Equipment assemblies and unit's delivery the packing of glass, plastics or paper the specification of packing with the material and weight characteristics are to be indicated.</p> <p>Hazardous goods must be packed as per international standards/practice.</p>	All Suppliers
9.	<p>Crates and packing material used for shipping will become the property of Customer / BHEL</p>	All Suppliers

	<b>PCRI-BOI DEPARTMENT</b> <b>BHARAT HEAVY ELECTRICALS LIMITED</b> <b>HEEP: HARDWAR-249 403 (Uttarakhand)</b> <b>TEL: +91 1334 28 1941</b>	<b>SHIPPING INSTRUCTIONS FOR</b> <b>2 x 660 MW MAITREE SUPER</b> <b>THERMAL POWER PROJECT,</b> <b>BANGLADESH</b>
---	---	---

**ANNEXURE-VII**

10.	Each part of the equipment which is to be shipped as a separate piece or smaller parts packed within the same case shall be legibly marked to show the unit of which it is part, and match marked to show its relative position in the unit, to facilitate assembly in the field. Unit marks and match marks shall be made with steel stamps and with paint	All Suppliers
11.	<b>Advance intimation to BHEL:</b> All supplying vendors will give at least 15 days advance intimation to BHEL along with package details before actual dispatches to arrange for storage/shipping arrangements by BHEL. Information must be sent to consolidate the details and arrange for shipments in time.	All Suppliers
12.	All Indian Suppliers to ensure compliance of Integrated Tax (Rate) Notification No. 41 of 2017 Dtd. 23 <sup>rd</sup> Oct 2017.	All Suppliers
13.	<p>Following Documents are to be submitted by Supplier:</p> <ul style="list-style-type: none"> <li>• Packing List</li> <li>• LR Copy / Bill of Lading / AWB marked freight pre-paid.</li> <li>• Fumigation certificate for wooden boxes</li> <li>• CE Certificate for DEEC shipping bill cases with original import license</li> <li>• MSDS for DGR cargo</li> <li>• Warranty Certificate</li> <li>• Manufacturer's Factory Test Certificate/Inspection Waiver Certificate</li> <li>• Quality and Quantity Certificate</li> <li>• Certificate of Origin</li> <li>• MDCC</li> </ul>	All Suppliers
14.	<b><u>Certified Inspection Certificate Approved by Customer:</u></b> The certificate signed by BIFPCL inspector (if equipment tested in presence of BIFPCL representative) is to be provided to MEPG. In case the Certificate is signed by BHEL/Third Party Inspection Agency, it is to be provided by suppliers to along with the shipping / dispatch documents.	All Suppliers
15.	<p>Following details to be mentioned in GST Invoice for Export-</p> <ol style="list-style-type: none"> <li>1. Forex Bank Account no. for all type of Shipping Bill.</li> <li>2. Authorized Dealer Code no. with Name of Bank for all type of Shipping Bill.</li> <li>3. Duty Drawback Account no. with IFS code of Bank for Drawback Shipping Bill.</li> </ol> <p>As invoice will be used for export custom clearance details like HS code; CIF value, Freight value, Insurance value, FOB value in FC ; Shipper name ;Manufacturer name; Shipping bill type; POL; POD; DBK serial no ; Advance authorization no., EPCG License no as applicable should appear on invoice.</p>	All Suppliers

**Buyer Specific ATC document for “Gas Chromatograph for Drinking Water Analysis” & “Gas Chromatograph for Natural Gas Analysis” of Maitree (Bangladesh) Project**

1.	<p><b>MDCC (Material dispatch clearance certificate) Clause:</b></p> <p>Please note that material shall be dispatched only after issue of Material dispatch clearance certificate (MDCC) by BHEL. For issue of MDCC, you are required to submit the set of documents (i.e. Packing List, Guarantee Certificate, Cylinder TC &amp; CCOE Certificate for cylinders, Complete Test Inspection Reports including Calibration of detector, Carrier gas flow controller &amp; Column oven temperature etc).</p> <p>BHEL will release MDCC within 07 days from the date of receipt of completed documents as detailed above.</p> <p>The delivery period of 120 days is inclusive of 07 days taken by BHEL to issue MDCC.</p>
2.	<p><b>Pre-Qualification Requirement (PQR):</b></p> <p>The Pre-Qualification Requirements have been made part of bid as <b>ANNEXURE-1</b>. All the bidders should ensure submission of complete details and documents as called for in the same. The offers submitted by the bidders would be scrutinized with respect to Pre-Qualification Requirements first.</p> <p><b>Techno-Commercial offer of only those bidders shall be evaluated who meet the Pre-Qualification Requirements.</b></p>
3.	<p><b>Technical Specification Requirement:</b></p> <p>(i) Please quote your valuable offer as per <u>Technical Specifications</u> enclosed with the bid as follows:</p> <p>Gas Chromatograph for Drinking Water Analysis: <b>ANNEXURE-2</b> Gas Chromatograph for Natural Gas Analysis: <b>ANNEXURE-3</b></p> <p>(ii) Bidders to upload signed and stamped copy of Technical Specification(s) along with the offer as a token of acceptance.</p>
4.	<p><b>Evaluation criteria:</b></p> <p>1. Evaluation will be done on the basis of Total Landed cost up to Kolkata Port (<b>item wise</b>). Address of Kolkata Sea-Port is given below:</p> <p><b>KPD-1, Kolkata Port Trust</b> <b>Gate No. 2,</b> <b>Kolkata</b></p> <p>2. <b>Bidders can quote for single item also.</b></p>

5.	<p><b>Payment Terms:</b></p> <ul style="list-style-type: none"> <li>• 90% payment after receipt of material at site against submission of PBG @ 10% of Order value valid till entire Guarantee / Warranty period. PBG would be submitted before the negotiation of documents. The PBG will be in BHEL format and from one of the BHEL consortium banks. For name of BHEL consortium bank, please visit our website <a href="http://hwr.bhel.com">hwr.bhel.com</a>.</li> <li>• Balance 10% payment after successful installation and commissioning at site.</li> <li>• Payment will be released by BHEL within: <ul style="list-style-type: none"> <li>- 45 days for Micro and Small enterprises</li> <li>- 60 days for Medium enterprises</li> <li>- 90 days for Non MSME enterprises</li> </ul> </li> </ul>
6.	<p><b>Delivery Period:</b></p> <p>The delivery shall be 120 days from the date of placement of order on GeM. This period is inclusive of 7 days for BHEL to arrange dispatch clearance (provided MDCC related documents are complete in all respect).</p>
7.	<p><b>Document:</b></p> <p>One hard copy of O&amp;M manual in English language giving complete technical information for operation and maintenance of the equipment shall be supplied with the equipment.</p>
8.	<p><b>Price Basis:</b></p> <p>Please confirm that prices have been quoted on F.O.R. Kolkata Port basis.</p>
9.	<p><b>Installation and Commissioning:</b></p> <p>Installation &amp; Commissioning and Performance demonstration of the equipments as mentioned in BHEL Specifications is required at 660 MW Maitree STPP (Bangladesh) project site.</p> <p>Kindly confirm that Lumpsum I&amp;C charges for complete scope of work (inclusive of everything i.e. Visa charges, To &amp; Fro charges, local conveyance, lodging and boarding, taxes etc. and irrespective of no. of man-days) <b>has been included in quoted prices.</b></p> <p>Please note that the charges quoted for Installation &amp; Commissioning shall be inclusive of applicable Service tax &amp; TDS.</p> <p>Please note that BHEL will deduct tax from your bill of I&amp;C at the time of payment and furnish Tax Deduction at Source (TDS) Certificate.</p> <p>Deputation for Installation &amp; Commissioning shall be within 15 days of intimation from BHEL. All consumables &amp; necessary accessories required for I&amp;C would be carried by vendor's service engineer.</p>
10.	<p><b>Guarantee Clause:</b></p> <p>The equipment will be guaranteed / warranted for satisfactory performance for a period of 24 months from the date of Installation / Commissioning.</p> <p><b>Failing to comply to the Guarantee clause, the offer will be rejected straightaway.</b></p>

11.	<p><b>Packing Instructions for Maitree Project:</b></p> <p>Seaworthy Packing to be done by vendor as per Packing Instructions TGE-3646 Rev. 01 (<b>Annexure-VI</b>) enclosed. Kindly read the document carefully for quoting your offer accordingly and also submit the endorsed copy of this document as your acceptance for the conditions/instructions mentioned therein.</p> <p>Each Packing box shall have the following mentioned in Indelible ink “<b>Contract No. BIFPCL/ EPC-MAIN PLANT/2016/01</b>”.</p> <p>Vendor to inform the Maximum No. of Boxes / Packages to dispatch the complete quantity mentioned in tender enquiry.</p> <p>Each package should have inscriptions and signs stenciled with an indelible ink legibly and clearly. The Sl. No. of Package shall be indicated by vendor as Sl. No. <b>BHEL/MTR/BD/HWR/PCRI-BOI/17001 .....</b> so on.</p> <p>Kindly note that vendor to submit Packing List for approval from BHEL.</p>
12.	<p><b>Shipping Instructions for Maitree Project:</b></p> <p>Material shall be shipped as per Shipping Instructions (<b>Annexure-VII</b>) enclosed. Kindly read the documents carefully for quoting your offer accordingly and also submit the endorsed copy of this document of this document as your acceptance for the conditions/instructions mentioned therein.</p>
13.	<p><b>General Clause:</b></p> <p>All other commercial terms and conditions will be governed by General Terms and Conditions (GTC) GeM_GTC_4.0_v1.5_09Oct22.</p>
14.	<p><b>Risk Purchase:</b></p> <p>In case of abnormal delays (beyond the maximum late delivery period as per LD clause) in supplies / defective supplies or non-fulfillment of any other terms and conditions given in Purchase Order, BHEL may cancel the Purchase Order in full or part thereof, and may also make the purchase of such material from elsewhere / alternative source at the risk and cost of the supplier. BHEL will take all reasonable steps to get the material from alternate source at optimum cost. If bidder does not agree to the above Risk Purchase Clause, BHEL reserves the right to reject the offer. In case for compelling reasons BHEL accepts the offer without acceptance of this clause by the bidder and in the eventuality of Risk Purchase, appropriate action will be taken as per BHEL extant rules. This will be without prejudice to any other right of BHEL under the contract or under General Law.</p> <p><b>Action against Bidders / vendor / supplier / contractor in case of default:</b></p> <p>In order to protect the commercial interests of BHEL, BHEL shall take action against supplies / contractors by way of suspension of business dealings, who either fail to perform or are in default without any reasonable cause, cause loss of business/ money/ reputation, indulge in malpractices, cheating, bribery, fraud or any other misconduct or formation of cartels so as to influence the bidding process or influence the price etc.</p> <p>Suspension of Business Dealings could be in the form of “Hold” or “Banning” a supplier/ contractor or a bidder and shall be as per “Guidelines for Suspension of Business Dealings with Suppliers/ Contractors” available at BHEL’s website “<a href="https://www.bhel.com/guidelines-suspension-business-dealings-supplierscontractors">https://www.bhel.com/guidelines-suspension-business-dealings-supplierscontractors</a>”.</p>

15. **Arbitration Clause:**

In case of any dispute arising out of as in connection with this contract, the same shall be referred to arbitration under Arbitration & Conciliation Act 1996 of a sole arbitrator who shall be appointed by mutual consent of the parties. The seat & venue of arbitration shall be Haridwar.

The proceedings shall be conducted in English. The Governing law of contract shall be the substantive law of India.

16. **EARNEST MONEY DEPOSITE (EMD)**

13.1 Interested vendors must submit their offer along with the following Earnest Money Deposit (EMD) in a separate sealed envelope:

Details	Amount In INR	Amount in Foreign Currency	Type
EMD FOR BIDDER QUOTING FOR ONLY ONE (01) ITEM	<b>INR 60,000/-</b> (INR Sixty Thousand Only)	Equivalent Foreign currency	Refundable
EMD FOR BIDDER QUOTING FOR BOTH ITEMS	<b>INR 1,00,000/-</b> (INR One Lac Only)	Equivalent Foreign currency	Refundable

13.2 EMD shall not carry any interest.

13.3 Modes of deposits will be as per General Terms and Conditions (GTC) GeM\_GTC\_4.0\_v1.5\_09 Oct22.

The demand draft shall be in favor of "BHEL Haridwar". E-Payment is also acceptable. For e-payment, RTGS details are as mentioned below:

Bank Details	SWIFT Details of bank	Contact Details of Banker
STATE BANK OF INDIA RANIPUR BRANCH, OPP: BHEL MAIN GATE, SECTOR-5, RANIPUR, HARIDWAR, UTTRAKHAND, INDIA PIN CODE : 249403	SWIFT NO : SBININBB225 CC ACCOUNT NO : 10667995458 IFSC CODE : SBIN0000586	Chief Manager (IBD) Contact No. +91 1334 224201 +91 1334 226125 Fax: +91 1334 226512

13.4 MSE Suppliers / Central / State – PSUs / Government departments, who are the manufacturer of offered item as per specification are exempted from submission of the EMD.

13.5 EMD exemption will be allowed as per criteria laid down in General Terms and Conditions (GTC) GeM\_GTC\_4.0\_v1.5\_09 Oct22.

13.6 Bids not accompanied with requisite EMD or bids accompanied with EMD of inadequate value shall be liable for rejection, wherever exemption is not allowed.

13.7 The bidder whose bid is technically not accepted will be informed & EMD wherever submitted shall be refunded after the finalization of the contract. EMD shall be forfeited in the event of bidder opting out after tender opening (PART-I).

17. **Conflict of Interest among Bidders/ Agents:**

"A bidder shall not have conflict of interest with other bidders. Such conflict of interest can lead to anti-competitive practices to the detriment of Procuring Entity's interests. **The bidder, found to have a conflict of interest shall be disqualified.** A bidder may be considered to have a conflict of interest with one or more parties in this bidding process, if:

a) they have controlling partner (s) in common; **or**

b) they receive or have received any direct or indirect subsidy/ financial stake from any of them; **or**

c) they have the same legal representative/agent for purposes of this bid; **or**

d) they have relationship with each other, directly or through common third parties, that puts them in a position to have access to information about or influence on the bid of another Bidder; **or**

e) Bidder participates in more than one bid in this bidding process. Participation by a Bidder in more than one Bid will result in the disqualification of all bids in which the parties are involved. However, this does not limit the inclusion of the components/ sub-assembly/Assemblies from one bidding manufacturer in more than one bid; **or**

f) In cases of agents quoting in offshore procurements, on behalf of their principal manufacturers, one agent cannot represent two manufacturers or quote on their behalf in a particular tender enquiry. One manufacturer can also authorise only one agent/dealer. There can be only one bid from the following:

1. The principal manufacturer directly or through one Indian agent on his behalf; and

2. Indian/foreign agent on behalf of only one principal, **or**

g) A Bidder or any of its affiliates participated as a consultant in the preparation of the design or technical specifications of the contract that is the subject of the Bid; **or**

h) In case of a holding company having more **than** one independently manufacturing units, or more than one unit having common business ownership/management, only one unit should quote. Similar restrictions would apply to closely related sister companies. Bidders must proactively declare such sister/ common business/ management units in same/ similar line of business. "

## Certificate

In line with Government Public Procurement Order No. P-45021/2/2017-BE-II dt. 15.06.2017 & P-45021/2/2017-PP (BE-II) dated 28.05.2018, we hereby certify that we M/s \_\_\_\_\_(supplier name) are local supplier meeting the requirement of minimum local content (50%) as defined in above orders for the material against Enquiry No. \_\_\_\_\_

Details of location at which local value addition will be made is as follows:

\_\_\_\_\_

\_\_\_\_\_

We also understand, false declarations will be in breach of the Code of Integrity under Rule 175(1)(i)(h) of the General Financial Rules for which a bidder or its successors can be debarred for up to two years as per Rule 151 (iii) of the General Financial Rules along with such other actions as may be permissible under law.

Seal and Signature of Supplier