

Scope of Supply_ENSOF12285

Sl No.	Material Code	Matl Desc	Enquiry Qty (Nos.)	Drawing No. /Rev No.	Delivery Period From PO date	Supplier's Response (Quoted/not Quoted)
1	419020002000	EXT CIRCLIP-A20 -IS3075P1-N-d18.5	749	BPS:41902	8 Weeks	
2	419020002200	EXT CIRCLIP-A22 -IS3075P1-N-d20.5	100	BPS:41902	8 Weeks	
3	961920040000	GREASE NIPPLE-1553	4011	4V155307053/01	8 Weeks	
4	964523510000	RETAINER RING-4115	250	3V411507725/01	8 Weeks	
5	964524230000	PIN W/RING-Ø9.5x82(F/SLIP13-3/8CSG)-4129	40	4V412907525/02	8 Weeks	
6	964524240000	PIN WITH RING-6.4x60 -4126	100	4V412607522/02	8 Weeks	
7	964525180000	RETAINING RING-4167	100	3V416707725/01	8 Weeks	
8	964526550000	RETAINER RING-4235	50	3V423507725/01	8 Weeks	

Date:

Seal and Signature of authorized signatory



BHARAT HEAVY ELECTRICALS LIMITED

Tiruchirapalli-620014

List of documents to be submitted in part 1 bid

Enquiry No: ENSOF12285

To be eligible for award of contract, Bidder/OEM must possess following Certificates/Test Reports on the date of bid opening (to be uploaded with bid):

1. Signed Scope of supply
2. Signed schedule of deviation
3. Signed Confirmation to terms and conditions
4. Signed Drawings and BPS documents applicable for respective items quoted
5. Documents mentioned in PQR
6. Signed Enquiry General Terms and Conditions

Schedule of Deviations_ENSO12285

Sl No.	Material	Matl Desc	Enquiry Qty (Nos.)	Technical Deviation taken (if no deviation is taken, mention "No deviation")
1	419020002000	EXT CIRCLIP-A20 -IS3075P1-N-d18.5	749	
2	419020002200	EXT CIRCLIP-A22 -IS3075P1-N-d20.5	100	
3	961920040000	GREASE NIPPLE-1553	4011	
4	964523510000	RETAINER RING-4115	250	
5	964524230000	PIN W/RING-Ø9.5x82(F/SLIP13-3/8CSG)-4129	40	
6	964524240000	PIN WITH RING-6.4x60 -4126	100	
7	964525180000	RETAINING RING-4167	100	
8	964526550000	RETAINER RING-4235	50	

* If any deviation, Supplier has to mention "Devation Required". If no deviation, then supplier has to mention" no deviation" mandatory.

Date:

Seal and Signature of authorized signatory



BHARAT HEAVY ELECTRICALS LTD

VALVES PURCHASE

Trichy - 620 014. India

CONFIRMATION TO TERMS AND CONDITIONS

Enquiry Reference: ENSOF12285

<u>TERMS & CONDITION</u>	<u>VENDOR CONFIRMATION</u>
a. Quotation No and date	
b. Supplier shall be indigenous supplier.	
c. Vendor should give confirmation to BHEL's Technical Specification. Any deviations from the specification are to be furnished separately as "Schedule of Deviation". If there is no deviation vendor should indicate "No Deviation".	
d. The offer has to be submitted as a Two-part bid i.e. 1. Techno-commercial 2. Price bid	
e. The tender will be finalized on item wise basis	
f. Terms of Payment: <u>Indigenous Supplier (Non-MSE):</u> 100% direct EFT Payment after 60 days from the date of receipt and acceptance of materials at BHEL stores / against site acknowledgement. <u>Indigenous Supplier (MSE):</u> Payment will be as per MSMED Act, 2006. Suppliers quoting for MSE payment must produce Udyam registration certificate in part 1 bid documents.	
g. Liquidated Damage: Liquidated damages shall be 0.5% of the undelivered portion per week of the delay or part thereof subject to a maximum of 10% of the total order value.	
h. Delivery Terms: Prices shall be quoted on " FIRM PRICE " basis only. <u>For Indigenous Supplies:</u> FOR BHEL Trichy	
i. Validity of Offer: Prices should be valid for 90 days from the date of part-1 bid opening of this tender. The delay in responding to BHEL technical clarification beyond four days will be subsequently added to the validity period, Revised Price Bids will not be encouraged	
j. Delivery period: Delivery period should be 8 weeks from the date of purchase order. If supplier offers more than the required delivery period BHEL will operate 0.5% loading factor for evaluation of their offer for every week delay subject to a maximum of 2% . Any other delivery period after loading to maximum will be rejected.	
k. Risk Purchase: Risk purchase penalties as per clause 5 of general terms and conditions is applicable for this enquiry. Non acceptance to risk purchase clause the offer is liable for rejection.	
l. Guarantee Clause: The vendor shall give a guarantee for the performance of his supplies for a period of eighteen months from the date of dispatch or twelve months from the date of commissioning whichever is earlier.	
m. Performance Bank Guarantee: Performance Bank Guarantee is not applicable for this enquiry	
n. Counter-offering Counter-offering is not applicable for this enquiry.	

Supplier Seal and Sign



BHARAT HEAVY ELECTRICALS LIMITED

Tiruchirapalli-620014

PQR

Enquiry No: ENSOF12285

Pre-Qualification Requirement (To be submitted in Part-I bid):

- 1. Vendor to furnish records of previous supplies of enquiry items/similar items to any customer:** To fulfil this criteria vendor shall submit previous PO copy not more than 5 years old from date of part 1 bid opening and respective invoice for proof of completion.
- 2. Bidder to provide Certificate of Compliance for meeting the requirements of tendered items.**
- 3. Authorised Resellers/Distributors to submit "Authorised Reseller/Distributor certificate" mandatorily.**
- 4. Bidders are requested to detail out the deviations from this specification while submitting the offer. Even If no deviation is taken, vendor shall explicitly mention "No Deviation".**

ALL DIMENSIONS ARE IN MILLIMETRES. FOR TOLERANCES OF UNTOLERANCED DIMENSIONS DURING MANUFACTURE REFER RELEVANT QCP / QP.

SL No.	DRAWING NUMBER	MATERIAL CODE ON DIMENSIONS	MATL. SPECN.	TRUE ARC TYPE No.	DIMENSIONS						Wt (Kg)	BHEL PART No.	ALTERNATE EQUIVALENT IS No. (NOTE-2)	SUPERSEDED DRG.
					∅ D	t	B	E	J	∅ P				
01	3-V-4115-07725/01	96 452 351	CARBON SPRING STEEL SAE 1075	5100-300	70.49 ^{+0.50} / _{-0.76}	2.36 ±0.07	7.82 ±0.12	6.71 ±0.17	3.51 ±0.17	3.18 ^{+0.37} / _{-0.05}	0.024	4115005	A 75	VPS-001-9009/01
02	3-V-4116-07725/01	96 452 350		5100-362	85.14 ^{+0.50} / _{-0.76}	2.77 ±0.07	8.33 ±0.12	7.52 ±0.20	3.89 ±0.20	3.18 ^{+0.37} / _{-0.05}	0.035	4116005	A 90	VPS-002-9009/01
03	3-V-4167-07725/01	96 452 518		5100-450	107.27 ^{+0.50} / _{-0.76}	2.77 ±0.07	10.26 ±0.20	7.24 ±0.25	3.25 ±0.25	3.18 ^{+0.37} / _{-0.05}	0.048	4167005	A 115	VPS-003-9009/01
04	3-V-4190-07725/01	96 452 546		5100-550	131.11 ^{+0.50} / _{-1.01}	3.18 ±0.09	12.62 ±0.18	9.91 ±0.25	5.31 ±0.25	3.96 ^{+0.50} / _{-0.12}	0.08	4190005	A 140	VPS-004-9009/01
05	3-V-4235-07725/01	96 452 655		5100-162	38.18 ^{+0.32} / _{-0.50}	1.58 ±0.07	5.97 ±0.10	4.57 ±0.15	2.46 ±0.14	3.18 ^{+0.37} / _{-0.05}	0.01	4235004	-	VPS-005-9009/01
06	3-V-4345-07725/01	96 452 904		-	44.5 ^{+0.39} / _{-0.78}	0 1.75 -0.06	6.9 MAX.	5 (APPROX)	-	2.5 min.	0.01	4345004	A 48 x 1.75	VPS-006-9009
07	3-V-4769-07725/01	96 464 355	AISI 302	-	36.5 ^{+0.39} / _{-0.78}	0 1.75 -0.06	6.0 MAX.	4.4(APPROX)	-	2.5 min.	0.01	4769046	A 40 x 1.75 W/MATL. AISI 302	VPS-007-9009/01
08	3-V-R922-07725/01	96 464 577	CARBON SPRING STEEL SAE-1075	-	94.5 ^{+0.50} / _{-1.08}	3.18 ±0.09	9.6 MAX.	9.0 ±0.25	-	3.5 min.	0.01	R922	A 100 x 3.18	-
09	3-V-4000-07725/01	96 464 658		5100-375	88.10 ^{+0.50} / _{-0.76}	2.77 ±0.07	8.43 ±0.12	7.87 ±0.20	4.06 ±0.20	3.18 ^{+0.37} / _{-0.05}	0.037	4000027	-	F/RMFR
10	3-V-4B75-07725/01	96 464 700		5100-315	73.5 ±0.50	2.36 ±0.07	7.82 ±0.12	6.95 ±0.17	3.50 ±0.20	3.12 ^{+0.4} / _{-0.05}	0.03	4B75003	-	LANDING MANDREL 2-7/8"
11	3-V-4L10-07725/00	96 469 094		-	23.20 ^{+0.21} / _{-0.42}	0 1.20 -0.05	4.4 MAX.	3.0 (APPROX)	-	2.0 min.	0.01	4L10046	-	F/ 2-1/16"-15M CLE. PIN

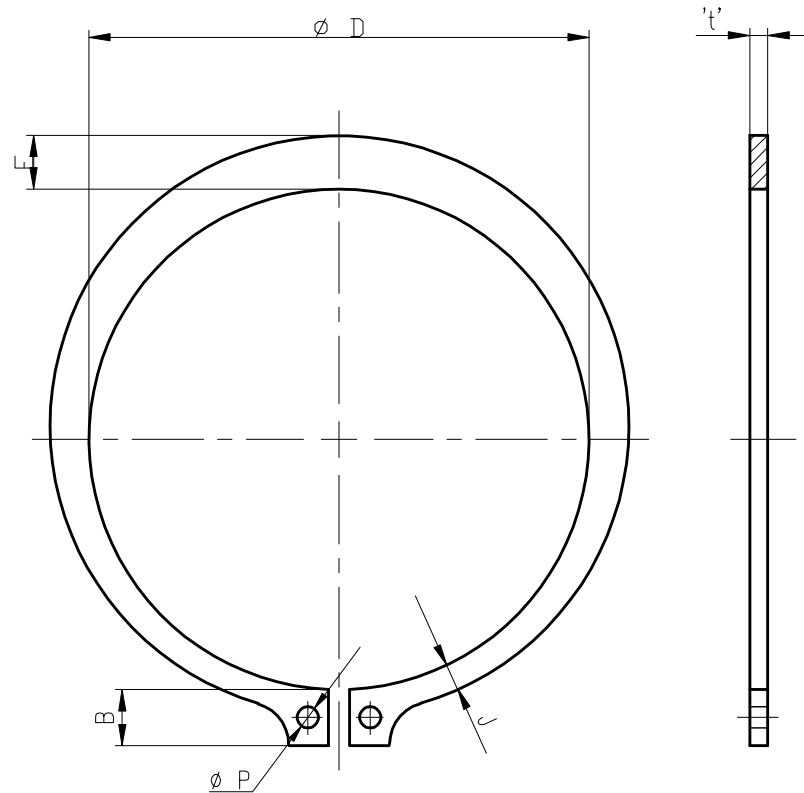

NOTES:-

1. TO BE BLACKENED. (EXCEPT SL No. 07)
2. ALTERNATE RETAINER RINGS SHALL CONFORM TO "IS 3075"
-CIRCLIPS FOR SHAFTS NORMAL TYPE.

NO OFF	DESCRIPTION	MATL CODE	MATL SPECN	HEAT TREATMENT	SCRAP SORT	NET WT (kg)	GROSS WT (kg)	DRAWING No	ITEM No
--------	-------------	-----------	------------	----------------	------------	-------------	---------------	------------	---------

TYPE OF PRODUCT
OR NAME OF
CUSTOMER/PROJECT

 365-121	BHARAT HEAVY ELECTRICALS LTD., UNIT: HIGH PRESSURE BOILER PLANT. TIRUCHIRAPALLI-620014.		DRN	R.NATARAJAN	SIGN		DATE	18-12-2010	NO. OF VAR.
	CHD	R.NATARAJAN	SIGN		DATE	18-12-2010			
	APPD	R.ELAYARAJA	SIGN		DATE	18-12-2010			

DCP No.	ALTERED	APPD
	CHD	DATE 18-12-'10

REV	05	SL. No. 11 ADDED.
ZONE		REVISED & REDRAWN IN CAD

CAUTION: The information on this document is the property of BHARAT HEAVY ELECTRICALS LTD. It must not be used directly or indirectly in any way detrimental to the interest of the company.

DEPT	VL	SCALE	WEIGHT (KG).	REFERENCE INFORMATION	NO. OF ITEMS
CODE	340	N T S			
TITLE			CARD CODE	DRAWING NO.	REV
RETAINER RING (EXTERNAL SERIES)			U 01	3-V-0000-07725	05

FOR TOLERANCES OF UNTOLERANCED DIMENSIONS

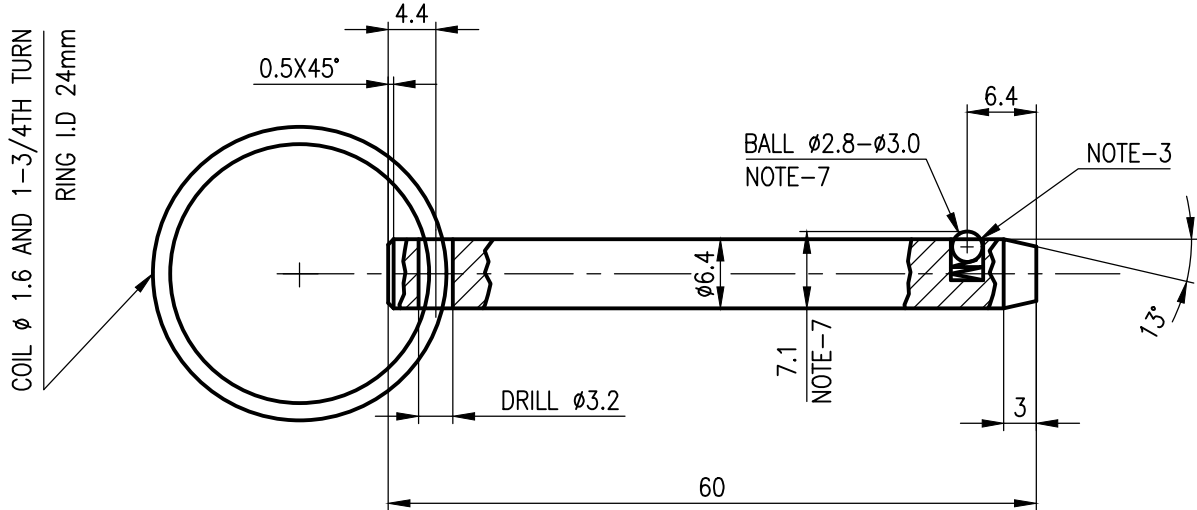
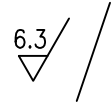

ALL DIMENSIONS ARE IN MILLIMETRES.
DURING MANUFACTURE REFER RELEVANT QCP/QP

DCP No.	ALTERED : G.V	CHD : R.N
802107	DATE :03-11-15	APPD : R.E
REV	REVISED AND REDRAWN IN CAD	
02		
ZONE		



NOTE:-

1. UNSPECIFIED ANGLE TOLERANCES $\pm 1/2^\circ$
2. UNSPECIFIED MACHINING TOLERANCES $\pm 0.25\text{mm}$
3. BY PUNCHING TO PREVENT THE BALL FROM COMING OUT.
4. TO BE CHROMIUM PLATED.
5. HARDNESS 29 HRC TO 32 HRC.
6. MATERIAL:- AISI 1040 OR AISI 4140 OF HIGH CARBON STEEL.
7. THIS DIMENSION (BALL IN PRESSED CONDITION) SHOULD SUIT TO THE MATING HOLE $\phi 6.7$.
8. SUPPLY THE PIN WITH TAG MARKED - '4126.'

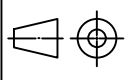
		96 452 424	NOTE-6			0.02				
NO OFF	DESCRIPTION	MATL CODE	MATL SPECN	HEAT TREATMENT	SCRAP SORT	NET WT (kg)	GROSS WT (kg)	DRAWING No	ITEM No	
		BHARAT HEAVY ELECTRICALS LTD., UNIT: HIGH PRESSURE BOILER PLANT. TIRUCHIRAPALLI 620014.			DRN	NAME		SIGN	DATE	NO. OF VAR
365-122					CHD	T.RAJARAMAN		T.R	16.01.1986	—
					APPD	V.ALAGARSWAMI		V.A	16.01.1986	—
						K.RAMALINGAM		K.R	17.01.1986	—
DEPT VL			SCALE	WEIGHT (KG).	REFERENCE INFORMATION					NO. OF ITEMS
CODE 340			NTS	—	NATIONAL PART No. 7915040					—
TITLE				CARD CODE	DRAWING NO.				REV	
PIN				U 01	4-V-4126-07522				02	
(FOR CONVENTIONAL SLIP) 9-5/8" CASING.										

CAUTION: The information on this document is the property of BHARAT HEAVY ELECTRICALS LTD. It must not be used directly or indirectly in any way detrimental to the interest of the company.

CAUTION: The information on this document is the property of BHARAT HEAVY ELECTRICALS LTD. It must not be used directly or indirectly in any way detrimental to the interest of the company.

FOR TOLERANCES OF UNTOLERANCED DIMENSIONS

ALL DIMENSIONS ARE IN MILLIMETRES.
DURING MANUFACTURE REFER RELEVANT QCP/QP

DCP No. 802322	ALTD: A.K.P. CHD: R.E.	APPD: R.E. DT: 08.02.18
REV 02	REVISED AND REDRAWN IN CAD	
ZONE 02		

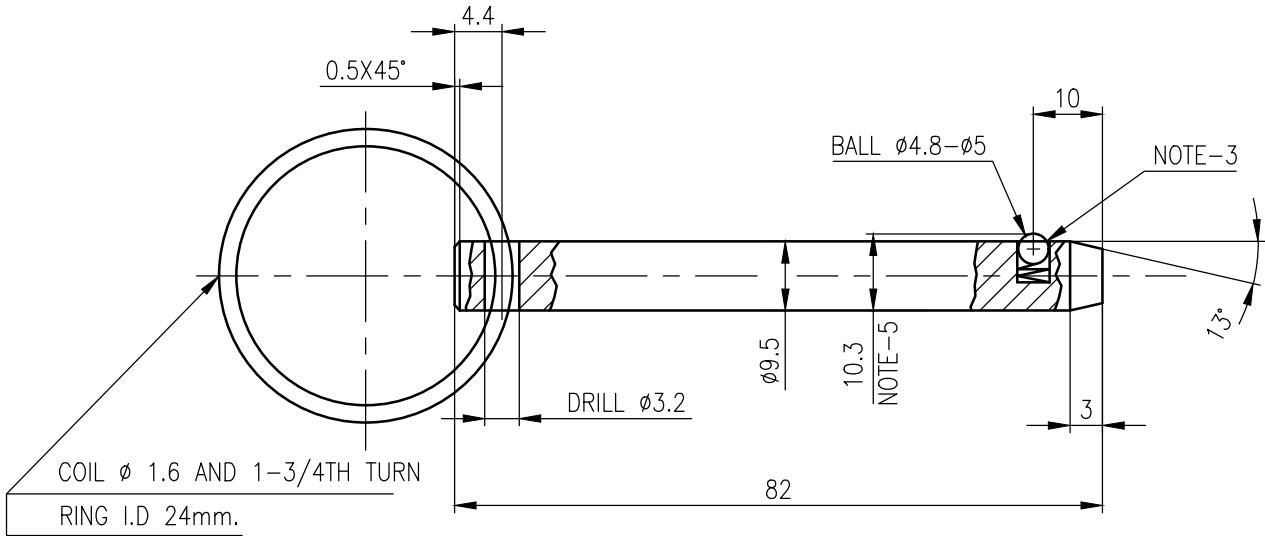

NOTES:-

- UNSPECIFIED ANGLE TOLERANCE $\pm 1/2^\circ$
- UNSPECIFIED MACHINING TOLERANCE $\pm 0.25\text{mm}$.
- BY PUNCHING TO PREVENT THE BALL FROM COMING OUT.
- TO BE CHROMIUM PLATED.
- THIS DIMENSION (BALL IN PRESSED CONDITION) SHOULD SUIT TO THE MATING HOLE $\phi 9.9$
- MATERIAL:- AISI 1040
- ALTERNATE MATERIAL : AISI 4140
- HARDNESS (29-32) HRC.
- SUPPLY THE PIN WITH TAG MARKED '4129'

-	-	964524230000	NOTE-6 & 7	-	-	0.04	-	-	-
NO OFF	DESCRIPTION	MATL CODE	MATL SPECN	HEAT TREATMENT	SCRAP SORT	NET WT (kg)	GROSS WT (kg)	DRAWING No	ITEM No
		BHARAT HEAVY ELECTRICALS LTD., UNIT: HIGH PRESSURE BOILER PLANT. TIRUCHIRAPALLI 620014.			DRN	T.RAJARAMAN	SIGN	DATE	NO.OF VAR
365-122					CHD	V.ALAGARSWAMI	SIGN	DATE	---
					APPD	K.RAMALINGAM	SIGN	DATE	---
DEPT VL	CODE	340	SCALE	NTS	WEIGHT (KG).	-	REFERENCE INFORMATIONS	NATIONAL PART NO.	NO. OF ITEMS
							7915041		
TITLE					CARD CODE	DRAWING NO.			REV
PIN 13 3/8" CASING (FOR CONVENTIONAL SLIP)					U 01	4-V-4129-07525			02

DCP No. 800479	ALT: <i>Raj</i>	APPD: <i>Mparamani</i>
	CHD: <i>Raj</i>	DATE: 27-6-05
REV 01	REVISED AND REDRAWN IN CAD	
ZONE 		

CAUTION: The information on this document is the property of BHARAT HEAVY ELECTRICALS LTD. It must not be used directly or indirectly in any way detrimental to the interest of the company.

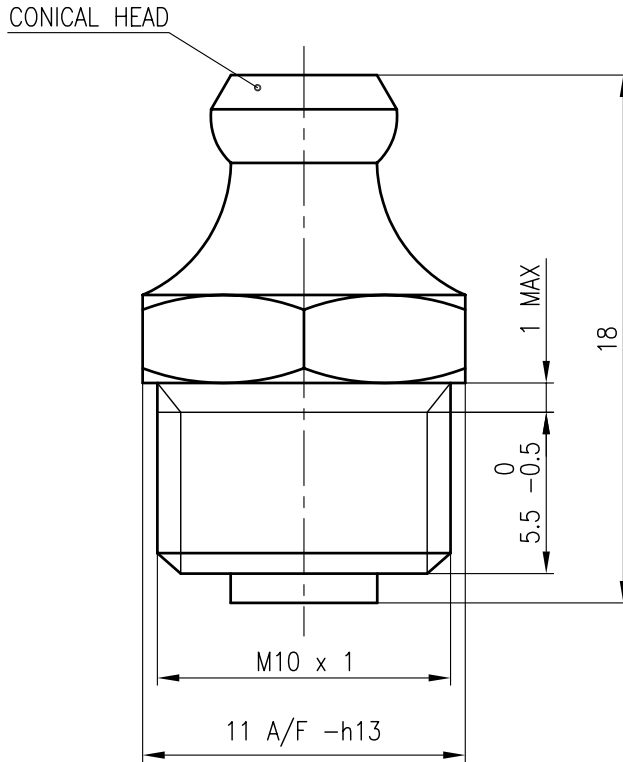

DESIGNATION : CONICAL HEAD GREASE NIPPLE M10x1-IS:4009

DIMENSION : AS PER IS:4009-1967

MATERIAL : STEEL CONFIRMING TO CLASS 4.8 OF IS : 1367-1967.

CAD REF No. o407053

COMP.CODE : 96 192 004 0000

NO OFF	DESCRIPTION	MATL CODE	MATL SPECN	HEAT TREATMENT	SCRAP SORT	NET WT (kg)	GROSS WT (kg)	DRAWING No	ITEM No
 365-122	BHARAT HEAVY ELECTRICALS LTD., UNIT: HIGH PRESSURE BOILER PLANT. TIRUCHIRAPALLI 620014.	DRN	T.RAJARAMAN	SIGN	<i>Rajaraman</i>	DATE	27-6-05	NO. OF VAR	
		CHD	T.RAJARAMAN	SIGN	<i>Rajaraman</i>	DATE	27-6-05		
		APPD	V.ALAGARSWAMI	SIGN	<i>Mparamani</i>	DATE	27-6-05		
DEPT VL	—		SCALE	WEIGHT (KG).	REFERENCE INFORMATIONS				NO. OF ITEMS
CODE 340			N T S	0.010	—				
TITLE					CARD CODE	DRAWING NO.			REV
GREASE NIPPLE					U 01	4-V-1553-07053			01



PLANT STANDARD

HPBP TIRUCHIRAPALLI

BPS: 41902

PAGE 1 OF 4

Based on IS: 3075-1965

EXTERNAL CIRCLIPS (Type A, Light Series)

1.0 SCOPE

Covers the requirements for Light Series External Circlips (type A), suitable for shaft diameter range 8 to 300mm.

2.0 SPECIFICATION AND REFERENCE STANDARDS

Dimensions and tolerances	Table 1 of this standard	
Material	High Carbon Steel C80	IS: 1570 Part II
Mechanical properties	(Hardness after tempering)	
		<u>Min</u> <u>Max</u>
	Upto and including 38mm	480HV 558HV
	Above 38mm upto 200mm	440HV 510HV
	Above 200mm	392HV 453HV
Finish	Sharp edges shall be removed, free from burrs, cracks, laminations and other defects. Chemically or thermally blackened.	
Sampling and Acceptability	Indian Standard	IS: 6821
General requirements	Circlips shall comply with IS: 3075 in respect of requirements not covered in this standard.	

2.1 Referred Standards (Only the current versions are applicable)

- IS: 1570 Schedule for wrought steels
Part II Part II Carbon steels (unalloyed steels)
- IS: 3075 Dimensions for circlips
- IS: 6821 Methods for sampling non-threaded fasteners.

COPYRIGHT AND CONFIDENTIAL
The information on this document is the property of BHARAT HEAVY ELECTRICALS LIMITED. It must not be used directly or indirectly in any way detrimental to the interest of the company.

REVISIONS	
DATE	

APPROVED		
STANDARDS SECTION ENGINEERING AND DEVELOPMENT CENTRE HPBP TIRUCHIRAPALLI		
PREPARED	ISSUED	DATE
HPBP TIRUCHY	STANDARDS ENGG.	DEC 1986



PLANT STANDARD

HPBP TIRUCHIRAPALLI

BPS: 41902

PAGE 2 OF 4

3.0 DESIGNATION

A Circlip to this standard suitable for shaft diameter 20mm shall be designated as:

3.1 On Drawings:

- i) Material Specification column : IS: 3075-A
- ii) Description column : CIRCLIP LIGHT A 20
- iii) Drawing Number column : 4190202000
- iv) Material Code column : 4190200020

3.2 Ordering Description

For placing indents, issuing enquiries and on purchase order, the Ordering Description given below shall be followed.

Circlip A 20x1.2* IS: 3075

4.0 ADDITIONAL INFORMATION

- *4.1 While preparing Ordering Description, the corresponding thickness for shaft diameter shall be filled in referring from Table.

COPYRIGHT AND CONFIDENTIAL

The information on this document is the property of BHARAT HEAVY ELECTRICALS LIMITED. It must not be used directly or indirectly in any way detrimental to the interest of the company.

DEC 1986

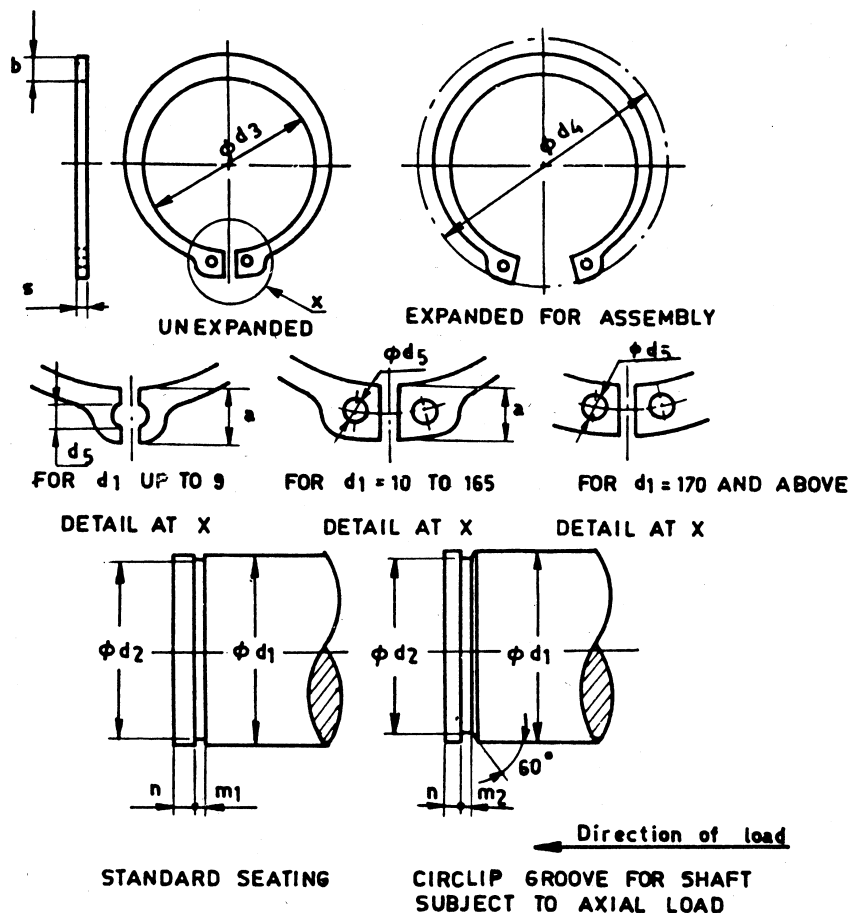
TABLE 1 - DIMENSIONS FOR INTERNAL CIRCLIPS, TYPE B - LIGHT SERIES

(All dimensions in millimetres)

Bore dia d_1	Circlip							Bore groove					Axial force kgf
	s h11	a Max	b	d_3	Tol on d_3	d_4 Com- pres- sed	d_5 Min	d_2	Tol on d_2	m_1 H13	m_2 Min	n Min	
8	0.8	3.2	1.5	7.4	+0.09	15.2	1.2	7.6	h11	0.9	1.0		120
9			1.7	8.4	-0.18	16.4	1.2	8.6				0.6	138
10			1.8	9.3	+0.15	17.6	1.5	9.6				0.6	153
12	1.0	3.5	1.8	11.0	+0.18 -0.36	19.6	1.7	11.5	h11	1.1	1.2	0.75	230
14			2.1	12.9		22.0		13.4				0.9	325
15			2.2	13.8		23.2		14.3				1.1	400
16			2.2	14.7		24.4		15.2				1.2	490
19	1.2	4.0	2.5	17.5	+0.21 -0.42	27.8	2.0	18.0	h12	1.3	1.4		725
20			2.6	18.5		29.0		19.0				1.5	770
22			2.8	20.5		31.4		21.0					845
24			3.0	22.2		33.8		22.9				1.7	1010
25			3.0	23.2		34.8		23.9				1.7	1060
28	1.5	4.7	3.2	25.9	+0.25 -0.50	38.4	2.5	26.6	h12	1.6	1.7	2.1	1500
30			3.5	27.9		41.0		28.6				2.1	1620
32			3.6	29.6		43.4		30.3				2.6	2100
35	3.9	32.2	47.2	33.0	3.0	2670							



PLANT STANDARD

HPBP TIRUCHIRAPALLI

BPS: 41902

PAGE 4 OF 4

38		5.8	4.2	35.2	+0.25	50.6		36.0					2910
40	1.75	6.0	4.4	36.5	-0.50	53.0		37.5		1.85	2.0	3.0	3810
45		6.7	4.7	41.5	+0.39	59.4		42.5				3.8	4300
50		6.9	5.1	45.8	-0.78	64.8	2.5	47.0					5700
56	2.0	7.3	5.5	51.8		71.6		53.0		2.15	2.3		6400
60		7.4	5.8	55.8		75.8		57.0				4.5	6900
70		8.1	6.6	65.5	+0.46	87.2		67.0	h12				8050
78	2.5	8.6	7.3	73.5	-0.92	96.2	3.0	75.0		2.65	2.8		9000
80		8.6	7.4	74.5		98.2		76.5					10700
85		8.7	7.8	79.5		104.0		81.5					11400
90	3.0	8.8	8.2	84.5		109.0		86.5		3.15	3.3	5.3	12100
95		9.4	8.6	89.5	+0.54	115.0	3.5	91.5					12800
100		9.6	9.0	94.5	-1.08	121.0		96.5					13500
110		10.1	9.6	103.0		132.0		106.0					17000
120		11.0	10.2	113.0		143.0		116.0					18500
130		11.6	10.7	123.0		155.0		126.0				6.0	20100
140		12.0	11.2	133.0		165.0		136.0					21700
150	4.0	13.0	11.8	142.0	+0.63	177.0		145.0		4.15	4.3		28900
160		13.3	12.2	151.0	-1.26	188.0		155.0					31000
170			12.9	160.5		197.0	4.0	165.0				7.5	32900
180			13.5	170.5		208.0		175.0	h13				34800
190				180.5		219.0		185.0					33500
200			14.0	190.5	+0.72	229.0		195.0					31900
220				208.0	-1.44	249.0		214.0				9.0	51200
240				228.0		269.0		234.0					52900
260	5.0			245.0		293.0		252.0		5.15	5.3		54400
280		16.0		265.0	+0.81	313.0	5.0	272.0				12.0	50800
300				285.0	-1.62	333.0		292.0					47300

Notes:

1. For stocked sizes and weights refer BPS component book-let.

Dec 1986

COPYRIGHT AND CONFIDENTIAL

The information on this document is the property of BHARAT HEAVY ELECTRICALS LIMITED. It must not be used directly or indirectly in any way detrimental to the interest of the company.



BHARAT HEAVY ELECTRICALS LTD

VALVES PURCHASE

Trichy - 620 014, India

GENERAL TERMS AND CONDITIONS

Enquiry Reference: ENSOF12285

1. QUOTATIONS:

- a. **BID system:** Offers are invited in any one of the below formats. The no. of bids to be submitted is mentioned in "Confirmation to the Terms and Conditions" attached.
- ~~Two part bid:~~ The offers are invited in Two part bid system (Part I will be Techno-commercial bid and part II will be Price Bid). Techno-commercially suitable vendors alone will be intimated for price bid opening.
 - ~~Single part bid:~~ The offers are invited in Single part bid system (Price Bid alone). The vendor shall confirm to all of BHEL's technical & commercial conditions.

b. **Submission of offer:**

- Offer called through e-Procurement mode: The bidder shall submit the bid online in BHEL e-Procurement portal at <https://eprocurebhel.co.in/nicgep/app>

The bidder would be required to register on the above e-procurement portal for submitting their bids. Offers through email and hardcopy are not acceptable.

~~ii.— Offer called through Non-e-Procurement mode:~~ Each part of offer should be sent in a double cover separately and the same should be sealed and super scribed with details such as enquiry reference, name of the vendor, item of supply and due date of opening. Two or more quotations should not be sent in one cover. Price Bid should contain only "Price per unit" for each type. Offer should be sent to the below mentioned address:

~~The Tender Opening Cell / Valves
Room No. 26, Building 24
Bharat Heavy Electricals Limited
Tiruchirappalli 620014, Tamil Nadu, India
Or
Email ID: tender_cell@bhel.in~~

- Late offers:** Offer received after 2.00 pm on due date will be considered as Late offers. Late offers will not be considered under any circumstance.
- Regulations:** Offers should be free from correction and erasures. Corrections if any must be attested. All amounts shall be indicated both in words as well as figures. In case of a difference between the amount quoted in words and figures, the amount quoted in words shall prevail.
- PVC:** Price Variation clause not acceptable. Prices should be firm.
- Catalogue:** Manufacturer's name, Trade Mark or Patent No. if any should be specified. Illustrative leaflets giving technical particulars are required along with quotation.
- Samples:** Samples should be submitted separately, if specially requested in tender, before the due date of the enquiry. They should be clearly marked with the enquiry reference and date on the enclosing cover to facilitate identification.
- GST Number:** GST registration number, HSN number (Item wise) with applicable taxes should be mentioned in the offer. If the vendor is not GST registered the offer is liable for rejection.
- Deviation.** Any deviations from the specification are to be furnished separately as "Schedule of Deviation". If there is no deviation, vendor should indicate "No Deviation" in the offer.
- Confirmation:** Confirmation for compliance is to be given in the offer for all the techno commercial conditions specified in the tender.

2. COMMERCIAL TERMS & CONDITIONS:

a. **Terms of Payment:**

For Indigenous Suppliers:

If the materials are receivable at BHEL Stores, Trichy:

Payment term is 100% direct Payment after 60 days from the date of receipt and acceptance of materials. (if PBG is not applicable)

(or)



BHARAT HEAVY ELECTRICALS LTD

VALVES PURCHASE

Trichy - 620 014, India

GENERAL TERMS AND CONDITIONS

Enquiry Reference: ENSOF12285

Payment term is 100% direct payment after 60 days from the date of receipt and acceptance of materials and against 10% PBG valid for the warranty period. (if PBG is applicable)

If the materials are receivable at site:

Payment term is 100% direct payment after 60 days from the date of dispatch against site acknowledgement (if PBG is applicable)

(or)

Payment term is 100% direct payment after 60 days from the date of dispatch against site acknowledgement and against 10% PBG valid for the warranty period (if PBG is applicable)

Any deviation in the above payment terms, any other conditions in payment terms or any other payment terms will not be accepted and offers will not be considered.

~~For Foreign Suppliers: Payment term is 100% payment on CAD basis after 60 days from the date of receipt of documents, specified in PO, at BHEL bank. Respective bank charges to respective account.~~

~~If supplier insists for LC, only Usance LC with 60 days' credit will be opened, one month prior to material readiness. Further loading will be considered @ 1.5% on the offered value. Hence, supplier shall intimate the material readiness accordingly for opening LC. LC validity period will be 90 days and for any extension, applicable charges will be to suppliers account.~~

Any deviation in the above payment terms, any other conditions in payment terms or any other payment terms will not be accepted and offers will not be considered.

For New Suppliers: For new suppliers not registered with BHEL, Trichy for the product, payment shall be made 60 days after receipt and acceptance of materials.

~~In case of foreign supplier, first lot of mutually agreed quantities shall be supplied with payment as CAD basis after 60 days from the date of receipt and acceptance of material. If insisted for LC after acceptance of first lot, only usance LC with 60 days' credit will be opened one month prior to material readiness.~~

b. Liquidated Damage: Liquidated damages shall be 0.5% of the undelivered portion per week of the delay or part thereof subject to a maximum of 10% of the total order value.

Any deviation from the above LD clause, loading will be applied to the extent to which it is not agreed by the bidder (at offered value)

Under GST regime, BHEL has to discharge GST liability on LD recovered from suppliers. Hence applicable GST shall also be recoverable from suppliers on LD amount. Debit note will be issued by BHEL for this amount, indicating the respective supply invoice number.

c. Delivery Terms:

For Indigenous Suppliers: FOR BHEL Trichy inclusive of freight and insurance

For Foreign Suppliers: CFR/CIF Chennai seaport as per Incoterms 2010.

d. Validity of Offer: Prices should be fixed and should be valid for period as mentioned in the "Confirmation to the Terms and Conditions" attached.

e. Delivery period: Delivery schedule will be as mentioned in the "Confirmation to the Terms and Conditions" attached. If supplier offers more than the required delivery period BHEL will operate 0.5% loading factor for evaluation of their offer for every week delay subject to a maximum of **2% (4 weeks' delay)**. Any other delivery period after loading to maximum will be rejected.

f. Guarantee period: The vendor shall give a guarantee for the performance of his supplies for a period of **eighteen months** from the date of dispatch or **twelve months** from the date of commissioning whichever is earlier.

g. Miscellaneous: Any conditions which might have been quoted by the seller and are in contravention to the terms of PO and which have not been specifically accepted by Purchaser will not be applicable to the contract/PO.

h. Performance Bank Guarantee: If tender calls for Performance Bank Guarantee, vendor should provide a performance bank guarantee (PBG) in BHEL format for 10% of the total Purchase order value valid for warranty/guarantee period with an additional claim period of 2 months. PBG should be issued from list of consortium banks.



BHARAT HEAVY ELECTRICALS LTD

VALVES PURCHASE

Trichy - 620 014, India

GENERAL TERMS AND CONDITIONS

Enquiry Reference: ENSOF12285

- i. **Counter Offering:** If counter offering is applicable for the enquiry, the L1 rates will be counter-offered to other eligible vendors as per below points
- In case there are only two qualified offers for any item, the L1 rate will be counter-offered to the L2 vendor.
 - In case of more than two qualified offers for any item, the L1 rates will be counter-offered to maximum (n-1) vendors (where 'n' is the no. of techno-commercially qualified vendors) or the no. of vendors required (as mentioned in the "Confirmation to the Terms and Conditions" attached), whichever is lower.
 - In case a lower ranked vendor does not accept the counter-offered rates, the rates may be offered to next higher ranked vendor.
 - The manner of splitting of the enquiry quantity across L1 and counter-offer accepted vendors will be as per the ratios mentioned in the "Confirmation to the Terms and Conditions" attached.

3. COMPLIANCE / ACCEPTANCE REQUIRED FOR FOLLOWING POINTS TO ENSURE INPUT TAX CREDIT

- a. Response to Tenders for Indigenous supplier/Vendor will be entertained only if the vendor has a valid GST registration No (GSTIN) which should be clearly mentioned in the offer. If the Vendor is exempted from GST registration, a declaration with due supporting documents need to be furnished for considering the offer. Vendor under composition scheme should declare that he is a composition Vendor supported by the screen shot taken from GST portal. The dealer has to submit necessary documents if there is any change in status under GST.
- b. Supplier shall mention their GSTIN in all their invoices (incl. credit Notes, Debit Notes) and invoices shall be in the format as specified/prescribed under GST laws. Invoices shall necessarily contain Invoice number (in case of multiple numbering system is being followed for billing like SAP invoice no, commercial invoice no etc., then the Invoice No. which is linked/uploaded in GSTN network shall be clearly indicated), Billed to party (with GSTIN) & Shipped to party details, item description as per PO, Quantity, Rate, Value, applicable taxes with nomenclature (like IGST, SGST, CGST & UTGST) separately, HSN/ SAC Code, Place of Supply etc.
- c. Invoices will be processed only upon completion of statutory requirement and further subject to following:
- i. Vendor declaring such invoice in Form GST ANX-1
 - ii. Receipt of Goods or Services and Tax invoice by BHEL
- d. All invoices shall bear the HSN Code for each item separately (Harmonized System of Nomenclature)/ SAC code (Services Accounting Code).
- e. As the continuous uploading of tax invoices in GSTN portal (in GST ANX-1) is available for all (i.e. both Small & Large) tax payers under proposed new GST Return System, all invoice raised on BHEL may be uploaded immediately in GST portal on despatch of material /rendering of services. The supplier shall ensure availability of Invoice in GST portal before submission of invoice to BHEL. Invoices will be admitted by BHEL only if the invoices are available in GSTN portal (in BHEL's GST ANX-2).
- f. A declaration to the effect that all invoice particulars are/were uploaded in the GSTN network/ portal & all tax liability as per GST rules and regulations have been and will be discharged, shall be mentioned in the invoice. If not mentioned in the invoice, a separate declaration shall be submitted as per the requirement of BHEL.
- g. All documents like Test Certificate, LR copy, any other document mentioned in PO, shall be sent along with the vehicle/consignment. For all consignments received within the calendar month, input credit will be availed within that month in line with monthly returns filing cycle. In case of any discrepancy in the document or non-submission of documents mentioned in the PO, then BHEL will not be able to accept or account the material, in such case availing of tax credit will be deferred to next month or so.
- h. In case of discrepancy in the data uploaded by the supplier in the GSTN portal or in case of any shortages or rejection in the supply, then BHEL will not be able to avail the tax credit and will notify the supplier of the same. Supplier has to rectify the data discrepancy in the GSTN portal or issue credit note or debit note (details also to be uploaded in GSTN portal) for the shortages or rejections in the supplies or additional claims, within the calendar month informed by BHEL.
- i. In cases where invoice details have been uploaded by the vendor but failed to remit the GST amount to GST Department (Form PMT-08 or Form GST RET-01 to be submitted) within stipulated time, then GST paid on the invoices pertaining to the month for which GST return not filed by the vendor will be recovered from the vendor along with the applicable



BHARAT HEAVY ELECTRICALS LTD

VALVES PURCHASE

Trichy - 620 014, India

GENERAL TERMS AND CONDITIONS

Enquiry Reference: ENSOF12285

interest (currently 24% p.a) and all subsequent bills of the vendor will not be processed till filing of the GST return by the vendor.

- j. Under GST regime, BHEL has to discharge GST liability on LD recovered from suppliers/contractors. Hence applicable GST shall also be recoverable from suppliers/contractors on LD amount. For this, debit note will be issued by BHEL indicating the respective supply invoice number.
- k. In case any changes in taxes and duties as per Gov. Notification (including GST), the same shall be applicable from time to time.
- l. Duplicate copy of the Invoice meant for the transporter should accompany the material as stipulated under CE Rules 52A and 172C OR 57CE.
- m. TDS on GST shall be applicable as per the GST Act.
- n. In case GST credit is denied to BHEL due to non-receipt or delayed receipt of goods and/ or tax invoice or expiry of timeline prescribed in GST law for availing such ITC, or any other reasons not attributable to BHEL, GST amount claimed in the invoice shall be disallowed to the vendor.
- o. Where any GST liability arising on BHEL under Reverse Charge (RCM), the vendor has to submit the invoices to BHEL well within the timeline prescribed in GST Law, to enable BHEL to discharge the GST liability. If there is a delay in submission of invoice by the vendor resulting in delayed payment of GST by BHEL along with Interest, then such Interest payable or paid shall be recovered from the vendor.
- p. GST TDS will be deducted as per Section 51 of CGST Act 2017 and in line with Notification 50/2018 – Central Tax dated 13.09.2018. GST TDS certificate which will be generated in GST portal subsequent to vendor accepting the TDS deduction in the GST portal, will be issued to the vendor.

4. SPECIAL PROVISIONS FOR MICRO AND SMALL ENTERPRISES (MSE):

- a. 25% of the tendered quantity is earmarked for MSE suppliers in this tender.
- b. If L1 vendor (or) Counter offer accepted vendor/s is from a Micro / Small enterprise which put together covers 25% of the total tendered quantum, the 25% earmarking provision is not applicable.
- c. Out of the 25% tendered quantity reserved for MSE suppliers, 6.25% shall be earmarked for procurement from MSE owned by SC / ST entrepreneurs. In the event of failure of such Micro and Small enterprises to participate in the tender process or meet the tender requirements and the L1 price, the 6.25% sub-target for procurement ear-marked MSE owned by SC / ST entrepreneurs shall be met with other MSE enterprise/s.
- d. 3% reservation for women owned MSEs within the above mentioned 25% reservation. In the event of failure of such Micro and Small enterprises to participate in the tender process or meet the tender requirements and the L1 price, the 3% sub-target for procurement ear-marked MSE owned by women entrepreneurs shall be met with other MSE enterprise/s. The definition for MSEs owned by Women Entrepreneurs is clarified as:
 - i. In case of proprietary MSE, proprietor shall be woman.
 - ii. In case of partnership MSE, the women partners shall be holding at least 51% share in the unit.
 - iii. In case of private limited companies, at least 51% share shall be held by the women promoters.
- e. In case MSE vendor participating in the tender quotes within the price band of LI +15%, they will be allowed to supply the portion of the requirement subject to acceptance of LI price by MSE vendor. In case of more than one such MSE, the supply shall be shared proportionately, provided the available quantum can be split.
- f. In a tender where both MSE and Non-MSE Vendors have participated and non-MSE Vendor has become the lowest bidder and the quantum envisaged in the tender cannot be split, then the MSE vendor will be given preference for ordering the available quantum provided the MSE vendor quoted price is within L1 + 15%, and if the MSE vendor accepts the L1 rate.
- g. MSE suppliers can avail the intended benefits only if,
The vendor submits along with offer, a copy of the Udhog Aadhar and a certificate, as per the format in Annexure-A, issued by a chartered accountant during the financial year of the date of part-1 bid opening, certifying that the quantum of investment in plant and machinery is within the permissible limit as per the act for relevant status (Micro or small).

(or)

The vendor has already submitted the above documents for the financial year of the date of part-1 bid opening and the MSE status has been updated in BHEL Trichy's records.



BHARAT HEAVY ELECTRICALS LTD

VALVES PURCHASE

Trichy - 620 014, India

GENERAL TERMS AND CONDITIONS

Enquiry Reference: ENSOF12285

Non submission of such documents will lead to consideration of their bids at par with other bidders and MSE status of such suppliers shall be shifted to Non MSE supplier till the supplier submits these documents.

- h.** Definitions of MSEs owned by SC/ST is under:
- In case of proprietorship firm, proprietor must be SC/ST.
 - In case of partnership firm, the SC/ST partners must be holding at least 51% shares in the unit.
 - In case of private limited companies, at least 51% share must be held by SC/ST promoters.
 - The caste/Tribe/Community certificate issued by the following authorities in the prescribed form for SCs/STs can be considered.
- i.** Authorized to Issue SC/ST certificate:
- District Magistrate/Additional District Magistrate/Collector/Deputy commissioner/Additional Deputy Commissioner/Deputy collector/1st class stipendiary magistrate/Sub divisional Magistrate/Taluka Magistrate/Executive magistrate/Extra Assistant commissioner.
 - Chief Presidency magistrate/Additional chief presidency magistrate/Presidency magistrate.
 - Revenue Officer not below the rank of tehsildar.
 - Sub-Divisional officer of the area where the individual and / or his family normally resides.
- j.** To avail the benefits of MSE under SC/ST category, the related documents as stated above should be submitted along with tender documents.
- k.** Payment for MSE vendors will be as per MSMED Act, 2006.

5. RISK PURCHASE PENALTIES

- a.** In case of delay in delivery beyond PO delivery /mutually agreed delivery, or vendor fails /refuses to complete the PO as per terms, or insufficient facilities at vendor's works to execute a PO, BHEL has the right to get the items ordered elsewhere at the risk and cost of the vendor with notice to the vendor and the additional expenditure / difference in cost, if any, including consequential cost shall be recovered from the defaulted vendor. Also, in such case of withdrawal of orders, BHEL shall recover the additional expenditure / difference from vendor by adjusting against amount due to vendor and/or by invoking the BG and/or by any other suitable means as decided by BHEL. In addition, BHEL may recover from the defaulter vendor any loss to BHEL arising due to withdrawal of orders in such case, and action shall be taken as per latest revision of BHEL Guidelines for Suspension of Business dealings with Suppliers / Contractors.
- b.** BHEL has the right to divert/cancel the order if the vendor has not procured minimum 50% of the quantity of raw materials within 60 days from PO date. Purchase order placed on steel mills and with proper payment voucher/proof will be considered for not cancelling the PO by BHEL. The submission of data by vendor for DB clearance by BHEL/QC shall be the proof of procurement. This is to avoid delay in project schedule due to delay in raw material procurement by vendors. In case the vendor fails to procure at least 50% of the quantity of raw materials within 60 days from PO date, BHEL has the right to get the items ordered elsewhere at the risk and cost of the defaulting Vendor and the additional expenditure / difference in cost, if any, including consequential cost shall be recovered from the defaulting Vendor and action shall be taken as per latest revision of BHEL Guidelines for Suspension of Business dealings with Suppliers / Contractors and SEARP.
- c.** The defaulted vendor shall be liable for any loss, which BHEL may sustain by reason of such risk purchases in addition to liquidated damages as mentioned under LD clause.
- d.** Vendors pending payments shall be withheld to cover the liabilities of BHEL towards risk purchase, if any.
- e.** Reasons like power cut, labour issues, machine break down, etc. which are controllable by the sub-contractor shall not be accepted as reason for delay for delivery extension purposes.
- f.** If PO delivery needs to be extended for reason attributable to BHEL, vendor may request BHEL in writing for delivery extension with justifications within 15 days from date of PO closure and before invoice.
- g.** Process of calculating the risk and cost amount is as follows:

$$\text{Risk \& Cost Amount} = [(A-B) + (A \times H/100)]$$

Where,

A= Value of Balance scope of Work/ Supply (*) as per rates of new contract



BHARAT HEAVY ELECTRICALS LTD

VALVES PURCHASE

Trichy - 620 014, India

GENERAL TERMS AND CONDITIONS

Enquiry Reference: ENSOF12285

B= Value of Balance scope of Work/ Supply (*) as per rates of old contract being paid to the contractor/ supplier at the time of termination of contract i.e. inclusive of PVC & ORC, if any.

H = Overhead Factor to be taken as 5

In case (A-B) is less than 0 (zero), value of (A-B) shall be taken as 0 (zero).

*(Balance scope of work/ supply)

Difference of Contract Quantities and Executed Quantities as on the date of issue of Letter for 'Termination of Contract', shall be taken as balance scope of Work/ Supply for calculating risk & cost amount. Contract quantities are the quantities as per original contract. If, Contract has been amended, quantities as per amended Contract shall be considered as Contract Quantities. Items for which total quantities to be executed have exceeded the Contract Quantities based on drawings issued to contractor from time to time till issue of Termination letter, then for these items total Quantities as per issued drawings would be deemed to be contract quantities. Substitute/ extra items whose rates have already been approved would form part of contract quantities for this purpose. Substitute/ extra items which have been executed but rates have not been approved, would also form part of contract quantities for this purpose and rates of such items shall be determined in line with contractual provisions. In-case portion of work is being withdrawn, contract quantities pertaining to portion of work withdrawn shall be considered as 'Balance scope of work/supply' for calculating Risk & Cost amount.

- h.** Vendors are cautioned that, withdrawal after price bid opening or after contract signing or PO/LOI acceptance will be construed as tampering with BHEL's tender process. Suitable action for suspension of further business with the vendor may be taken as per BHEL corporate procedures.
- i.** Abridged version of extant 'Guidelines for suspension of business dealings with suppliers/ contractors' has now been uploaded on www.bhel.com on "supplier registration page" at the following link: http://www.bhel.com/vender_registration/vender.php (Guidelines for suspension of business dealings with suppliers/ contractors).

6. GENERAL CONDITIONS

- a.** The manner of finalization will be as mentioned in the "Confirmation to the Terms and Conditions" attached. Separate orders will be released for each project and documents should be supplied for each order separately.
- b.** BHEL reserves the right to reduce the tender quantity and to NOT to order for some or all material based on the changes in project.
- c.** BHEL shall have the right to visit vendor works during the execution of contract along with end customer for verifying status, inspection and testing of the material.
- d.** BHEL reserves the right to negotiate or re-float the tender in case the quoted prices are not acceptable.
- e.** Supplier shall arrange packing to avoid lose or damages during Road Transport, Site handling & Storage.
- f.** BHEL reserves the right to reject the offer of a particular bidder due to unsatisfactory past performance in the execution of a contract at any of BHEL projects / units.
- g.** The Drawings and Technical documents given in this enquiry are the sole property of BHEL. This should not be misused in any form.
- h.** Purchase Order, PO Item serial number, Material code, Quantity should be clearly marked on the packing
- i.** Confirmation for compliance is to be given in the offer for all the conditions specified above and to the respective Purchase Specification.
- j.** The bidder along with its associate/collaborators/sub-contractors/sub-vendors/consultants/service providers shall strictly adhere to BHEL fraud prevention policy (refer www.bhel.com) and shall immediately bring to the notice of the BHEL management about any fraud or suspected fraud as soon as it comes to their notice.
- k.** For this procurement, Public Procurement (Preference to Make in India), Order 2017 dated 15.06.2017, 28.05.2018, 29.05.2019 and 04.06.2020, issued by DPIIT, Ministry of Commerce and Industry. If any subsequent Orders issued by the respective Nodal Ministry shall be applicable even if issued after issue of this NIT but before finalization of contract / PO / WO against this NIT. In the event of any Nodal Ministry prescribing higher or lower percentage of purchase and / or local content in respect of this procurement, same shall be applicable. Default purchase preference shall be 20% to local suppliers with default minimum local content of 50%.



BHARAT HEAVY ELECTRICALS LTD

VALVES PURCHASE

Trichy - 620 014, India

GENERAL TERMS AND CONDITIONS

Enquiry Reference: ENSOF12285

7. DOCUMENTATION:

- a. **With Consignment:** Duplicate for transporter copy, Original Invoice, Packing List, Delivery Challan, O&M manual (if applicable) Material Test Certificate, Test Certificates, Compliance Certificate, Guarantee/Warranty Certificate and other documents mentioned in PO/TDC/Drawing.
- b. **To Purchase:**
 - i. **FOR BHEL TRICHY case-** Original Invoice, Duplicate for transporter copy, Packing list, LWB and Delivery challan, GST declaration as mentioned in point 3c.
 - ii. **FOR Site case-** Original Invoice, Original LWB, Original Packing List, Original IBR documents, Original despatch clearance Certificate and Inspection report, Test certificates as per PO, Original Site Acknowledgment etc.
- c. **Identification:** Material code, Purchase Order, PO item serial number, Unique serial number if any should be provided in all despatch documents, materials and packing clearly.

8. TENDER EVALUATION:

a. Techno-commercial Bid.

- i. All vendors should submit General arrangement drawing, datasheet and C&I diagram (if any) of the offered product
- ii. Point by point technical confirmation of all pages of our technical specifications and commercial conditions are required with your sign and seal along with techno commercial offer.
- iii. Offers from supplier not having technical capability or not agreed for commercial terms, will be rejected.

b. Price Bid.

- i. Bidders qualified for part I will be intimated for participating in priced bid opening.
- ii. L1 bidder will be decided based on landed cost for the equipment to BHEL.

Indigenous Vendors

Total Landed cost/rate for each item = FOR Rate in INR (A) + Applicable Taxes (B) + Loading non-acceptance of commercial terms (C) – Applicable input tax credit (D)

A - Indigenous vendors submit offers on Free on Road (FOR), Stores, HPBP BHEL Trichy in INR.

B - Applicable GST and any other charges quoted by indigenous vendors will be added to the base price.

C - Loading for non-acceptance of payment terms, delivery schedule & liquidated damages (LD) will be added to the F.O.R. value for arriving the landed rate.

D - However, input tax credit shall be availed for GST, hence the same is excluded for arriving at the landed cost.

Foreign Vendors

Total Landed cost = CFR Rate in INR (A) + Applicable Duties (B) + Incidental Charges (C) + Loading for Container Shipment (D) + Loading for non-acceptance of commercial terms (E)

A - Foreign vendors to submit offers on CFR (Cost & Freight), Chennai port (LIFO – Liner In; Liner Out) basis per item wise in foreign currency, which will be converted to INR by multiplying with the Exchange rate (SBI TT Selling rate) as on the technical bid opening date. If the date of opening happens to be a bank holiday, then the forex rate as on previous bank (SBI) working day shall be taken.

B - Customs duty, Safe guard duty (as per the notification No 02/2014-Customs (SG) dated 13th August 2014) and antidumping duty (as per the notification No 18/2016-Customs (ADD) dated 17.05.2016) as if applicable will be added to the INR price.

C - Incidental charges will be added to the CFR Value. The incidental charge is inclusive of port handling charges, & freight charges for movement from Chennai port to BHEL, Trichy.

D - In case of shipment through containers, if 14 free days for Container detention is not provided in the offer, a loading of 22% on the freight rate per MT shall be considered by BHEL for arriving at the Total Landed Cost.

E - Loading for non-acceptance of payment terms, delivery schedule & Liquidated Damages (LD) will be added to the CFR value for arriving at the landed cost.

- iii. In case of tie for the L1 positions,



BHARAT HEAVY ELECTRICALS LTD

VALVES PURCHASE

Trichy - 620 014, India

GENERAL TERMS AND CONDITIONS

Enquiry Reference: ENSOF12285

- a. In the course of evaluation, if more than one bidder happens to occupy L1 status, effective L1 will be decided by soliciting discounts from respective L1 bidders.
 - b. In case more than one bidder happens to occupy the L1 status even after soliciting discounts, the L1 bidder shall be decided by a toss/draw of lots, in the presence of the respective L1 bidders(s) or their representative(s).
 - c. Ranking will be done accordingly, BHEL's decision in such situation shall be final and binding.
- iv. If counter-offer is applicable and before counter offer process, if there is tie for ranking position other than L1 in respective enquiry items, then Lot shall be done to break the tie. Based on the outcome of LOT, subsequent tender ranking will be revised. Load distribution shall be based on revised ranking. The LOT process to break tie in tender ranking will be based on random number generation in MS-Excel sheet.

Tie breaking procedure has been explained below with an example:

There is an item (item sl. no. 210) for which tie breaking has to be conducted. Hence, the lot will be based on random number generation in MS-Excel sheet.

1. Item wise excel sheet in which all ranks for which tie is present shall be opened.
2. Random number shall be generated against each entry in the excel sheet. Once random number is generated, the values will be frozen against each entry.
3. The rank order shall be sorted in the following manner.
Sorting -> 1. Item -> 2. Actual rank -> 3. Random number wise (from lowest to highest).
Once sorting is done, each vendor shall be ranked as per the sorting order.

• **Illustration:**

Step-1: Before Sorting:

Item No.	Vendor code	ORIGINAL Rank before CO
210	A	L01
210	B	L02
210	C	L03
210	D	L03
210	E	L04
210	F	L05
210	G	L05
210	H	L06

Step-2: After random number generation

Item No.	Vendor code	ORIGINAL Rank before CO	Random Number
210	A	L01	0.639156
210	B	L02	0.931402
210	C	L03	0.560449
210	D	L03	0.507298
210	E	L04	0.621819
210	F	L05	0.620683
210	G	L05	0.504936
210	H	L06	0.793407

Step-3: **Final sorting and revised ranking:**



BHARAT HEAVY ELECTRICALS LTD

VALVES PURCHASE

Trichy - 620 014, India

GENERAL TERMS AND CONDITIONS

Enquiry Reference: ENSOF12285

Item No.	Vendor code	ORIGINAL Rank before CO	Random Number	Final Revised Rank
210	A	L01	0.639156	L01
210	B	L02	0.931402	L02
210	D	L03	0.507298	L03
210	C	L03	0.560449	L04
210	E	L04	0.621819	L05
210	G	L05	0.504936	L06
210	F	L05	0.620683	L07
210	H	L06	0.793407	L08

Final revised ranking shall be intimated to vendors. Final revised ranking shall be worked out based on the result of tie-breaking and counter offering process shall be based on the final revised ranking.

L1 rate shall be counter offered to eligible Vendors in respective enquiry items in order of the distinct ranking arrived after tie-breaking process has been concluded.

9. IMPORTANT INFORMATION FOR FOREIGN SUPPLIERS:

- a. Port of loading should be indicated in the offer without fail.
- b. Port of discharge should be Chennai Sea/Air Port, India.
- c. The preferred shipment mode "Containerized Cargo or Break Bulk" shall be specified clearly in the offer.
- d. **In case of CFR INCO TERMS - CONTAINERIZED CARGO**
 - i. In case of CFR terms, moved through CONTAINERS (Suppliers should clearly specify this in their offer) it would be presumed by BHEL that the freight charges quoted is on LILO (LINER IN LINER OUT) basis including extra charges, if any, like Container Imbalance Charges, Trade Imbalance charges or any other charges payable to the Liner. No other charges other than the quoted Freight rate will be paid by BHEL excepting applicable Terminal Handling Charges, Container cleaning Charges, DO charges to Shipping Liner at Discharge Port. 14 FREE DAYS for Container detention shall be provided. If any deviation is taken by Tenderer, a loading of 22% on the freight rate per MT shall be considered by BHEL for arriving at the Total Landed Cost.
 - ii. In case of shipment through Containers on CFR basis, the BL should bear the endorsement that "14 free days for Container Detention is applicable".
- e. **In case of CFR INCO TERMS - BREAKBULK CARGO:** In case of CFR terms, moved through BREAK BULK BASIS (Suppliers should clearly specify this in their offer) it would be presumed by BHEL that the freight charges quoted is on LILO (LINER IN LINER OUT) basis. The materials will be Custom cleared from Port itself.
 - i. The Indian Customs imposed, a penalty on late filing of Bill of Entries (Air/Sea Shipments) by the importer. The maximum free time allowed is 24 hrs from the time of arrival of cargo at final port of discharge. Rs.5000/- per day (for Initial 03 days) & Rs.10000/- per day (thereafter)
 - ii. The vendor should furnish the Non-Negotiable Documents (Air Way Bill/Bill of Lading, Commercial Invoice, Packing List, and Certificate of Origin) either by email or post/courier to BHEL well before the landing of cargo at final port of discharge.
 - iii. Vendor will be held responsible for the penalty arises against the late filing of Bill of entry due to:
 - a. Non availability of Non-Negotiable Documents (NNDs) before the cargo arrival
 - b. Discrepancy in documents
 - c. Short landing of Consignments (For shipments on CFR/CPT/CIF/CIP - Chennai Port)
 - iv. All the shipments for the contracts (POs) finalized on CFR -Chennai Port basis
 - a. Delivery Orders involving multiple agencies like liners/freight forwarders are not allowed. There must be a single agency office at the final discharge Port (Chennai) for issuing the Delivery Order to BHEL.



BHARAT HEAVY ELECTRICALS LTD

VALVES PURCHASE

Trichy - 620 014, India

GENERAL TERMS AND CONDITIONS

Enquiry Reference: ENSOF12285

- b. The detention/demurrage charges arise due to the delay in collection of Delivery Orders from multiple agencies of liner/freight forwarder also whose offices are not at available Chennai, the same amount will be deducted from Vendor's bills only.
- c. Apart from the normal charges like Terminal Handling Charges, Container cleaning Charges, Delivery Order Charges at final port of discharge no other charges will be borne by BHEL.
- d. The liner/freight forwarders should be properly communicated by the Vendor for not to claim such charges for issuing Delivery Order. If the liner/freight forwarder claims such charges in their invoices, the same amount will be deducted from the Vendor bills without any prior intimation in order to avoid the delay in Customs clearance.

The likely additional/hidden costs or charges are:

- i. CIC - Container Imbalance Charges/Surcharges
- ii. EIC - Equipment Imbalance Charge/Surcharges
- iii. CAF - Container/Currency Adjustment Factor
- iv. BAF - Bunker adjustment Factor
- v. RDS - Rupee Depreciation Surcharge
- vi. CDS - Currency Depreciation Surcharge

f. Transport Conditions for Import:

The Original Documents (Bill of Lading, Invoice, Packing List, Certificate of Origin & Test Certificate) shall reach BHEL well in advance before the vessel arrival. The soft copies of the above shall be forwarded to BHEL immediately after shipment.

- i. In the event of delayed submission of documents by the supplier, an amount up to 5% of the invoice value will be retained towards demurrage & other charges and the difference if any between actual charges and recovery will be settled separately through supplementary invoice.
- ii. In such cases, the Supplier shall authorize the Steamer / Shipping agent / transporter to freely release the consignment to BHEL by providing a "Surrender Bill of Lading".
- iii. Otherwise, No-objection Certificate shall be issued to the Liner, authorizing BHEL to get the Delivery Order without producing the Original Bill of Lading.
- iv. This is required to ensure avoidance of demurrage at Chennai Sea-port that may arise in case of delayed presentation of documents by the Seller.

Following details to be endorsed in OBL

- i. Import & Export Code (IEC) of importer: 0588138690
- ii. GST Identification No (GSTIN) of importer: 33AAACB4146P2ZL
- iii. Official email id of importer: sivabala@bhel.in ; siyama@bhel.in

d. Indian Agent & Agency commission:

- i. An Indian Agent can represent / submit offer of only one original equipment manufacturer (OEM) against a particular Tender. If any Indian Agent represents two or more than one OEM against the same tender, then the Offer will be rejected.
- ii. The CFR - Cost and Freight Chennai Sea Port, price quoted by the Foreign Bidder shall also include the Agency commission. The bidder shall furnish authenticated copy of the Agency Agreement detailing the precise relationship between them and their mutual interest in the business so as to consider the offer of the Indian Agent for the indigenous portion of the supply. For the main equipment, the offer should be from the Principal / OEM. The bidders have to furnish the original Authorization Letter for the Indian Agent along with the Techno-Commercial Offer.

10. INTEGRITY PACT (IP)

- a. IP is a tool to ensure that activities and transactions between Company and its Bidders/Contractors are handled in a fair, transparent and corruption free manner. Following Independent External Monitors (IEMs) on the present panel have been appointed by BHEL with the approval of CVC to oversee implementation of IP in BHEL.

Sl.	IEM	Email
1	Shri Arun Chandra Verma, IPS (Retd.)	acverma1@gmail.com
2	Shri Virendra Bahadur Singh, IPS (Retd.)	vbsinghips@gmail.com



BHARAT HEAVY ELECTRICALS LTD

VALVES PURCHASE

Trichy - 620 014, India

GENERAL TERMS AND CONDITIONS

Enquiry Reference: ENSOF12285

- b. If IP is applicable for the enquiry, the IP as enclosed with the tender is to be submitted (duly signed by authorized signatory) along with the techno-commercial bid (Part-I, in case of two/three part bid). Only those bidders who have entered into such an IP with BHEL would be competent to participate in the bidding. In other words, entering into this pact would be a preliminary qualification.
- c. Please refer Section-8 of the IP for Roles and Responsibilities of IEMs. In case of any complaint arising out of the tendering process, the matter may be referred to any of the above IEM(s). All correspondence with the IEMs shall be done through email only.

Note:

No routine correspondence shall be addressed to the IEM (phone/post/email) regarding the clarifications, time extensions or any other administrative queries etc. on the tender issued. All such clarifications / issues shall be addressed directly to the tender issuing (procurement) department's officials whose contact details are provided below

(1)

Neeraj Kumar

Sr. Engineer

Valves Purchase

24 Building, 3rd Floor,

BHEL, Trichy-620014

+91 431 2578256

neerajkumar@bhel.in

(2)

Ajay Kumar Gupta

AGM

Valves Purchase

24 Building, 3rd Floor,

BHEL, Trichy-620014

+91 431 2578156

ajaykumar.gupta@bhel.in
