

**BHARAT HEAVY ELECTRICALS LIMITED**

[A Government of India Undertaking]

Ramachandrapuram, Hyderabad, 502032, A.P. India
Phone 040-23184526, 23182322 FAX:040-23021910, 1954**भारत हेवी इलेक्ट्रिकल्स लिमिटेड**

(भारत सरकार का उपक्रम)

रामचन्द्रपुरम, हैदराबाद, 502032 आंध्र प्रदेश, भारत

RFQ NO :

PURCHASE DEPARTMENT**ENQUIRY****क्रय विभाग**

जांच (ई मेल : tenderbox@bhellhyd.co.in)

SHEET:1
OF :2HY17001 C
REV.NO.0Phone 091-40-23184526
091-40-23182322FAX : 091-40-23021910
091-40-23021954**PURCHASE DEPARTMENT**

GSTIN:

Enq/Collective No :E5A1V04433

Enq.Dt. : 17.03.2022

No.Of Items :*

DUE Dt. OF QUOTN. : 07.04.2022

Office Copy

Please submit your lowest quotation in sealed cover superscribed with Enquiry No./Collective No.(RFQ No) and due date subject to our terms and conditions attached ,for the materials mentioned below. Your offer has to reach us on or before due date by 11.00 Hours (IST) and will be opened at 14.00 Hours.(IST).If our Enquiry No./Collective No.(RFQ No) and tender due date are not super scribed on the tender cover , your offer shall be summarily rejected. Incomplete offers and late offers will not be considered.

SL NO	Purchase Req.no	item no	Material Code, HSN No.	Drg no - Ver , Rev & Spec - Ver , Rev,Spec-Var	Description	Unit	Qty	Delivery Date	Schedule Qty
1	8000106222	10	HE9711343100 73079190	D41668006079-01,,NA,,NA	FR TS cladded FRG SA266G2 SA240S32750	EA	1.000	25.08.2022	1.000
2	8000106222	20	HE9711343118 73079190	D41668006079-02,,NA,,NA	FL TS cladded FRG SA266G2 SA240S32750	EA	2.000	25.08.2022	2.000
3	8000106382	60	HE9714714079 84199090	31668001789-03,,NA,,	CU-NI CLAD TSH MOCK UP(150X150X65THK)	KG	6.000	25.08.2022	3.000
4	8000106382	30	84199090					25.08.2022	3.000
5	8000104433	30	HE9715464149 7326	41668006035-03,,NA,,	AL-BRONZE CLAD MOCK UP PIECE(150X150)	EA	3.000	25.08.2022	3.000
6	8000106382	70	HE9718633146 74092900	31668001789-04,,NA,,NA	CU-NI CLAD FIX TUBESHEET (OD681X50THK)	EA	1.000	25.08.2022	1.000
7	8000106382	80	HE9718633154 74092900	31668001789-05,,NA,,NA	CU-NI CLAD FLOAT TUBESHEET(OD595X50THK)	EA	1.000	25.08.2022	1.000
8	8000106382	90	HE9718633162 74092900	31668001789-06,,NA,,NA	CU-NI CLAD TSH MOCK UP(150X150X50THK)	EA	3.000	25.08.2022	3.000
9	8000104433	10	HE9718634150 7326	41668006035-01,,NA,,	AL-BRONZE CLAD TUBE SHEET(OD879X175THK)	KG	1.000	25.08.2022	1.000
10	8000104433	20	HE9718634169 7326	41668006035-02,,NA,,	AL-BRONZE CLAD TUBE SHEET(OD716X175THK)	EA	1.000	25.08.2022	1.000

TEST CERTIFICATE REQD: Y
GUARANTEE REQ : Y
SAMPLE REQD : N
BID TYPE : TWO PARTFor and on-behalf of
Bharat Heavy Electricals Limited.P Reena Suresh Kumar
Manager/Purchase(HE&F)-
04023183530

**BHARAT HEAVY ELECTRICALS LIMITED**

[A Government of India Undertaking]

Ramachandrapuram, Hyderabad, 502032, A.P. India
Phone 040-23184526, 23182322 FAX:040-23021910, 1954**भारत हेवी इलेक्ट्रिकल्स लिमिटेड**

(भारत सरकार का उपक्रम)

रामचन्द्रपुरम, हैदराबाद, 502032 आंध्र प्रदेश, भारत

RFQ NO :

PURCHASE DEPARTMENT**ENQUIRY****क्रय विभाग**

जांच (ई मेल : tenderbox@bhelhyd.co.in)

SHEET:2
OF :2

HY17001 C REV NO.0	Phone 091-40-23184526 091-40-23182322	FAX : 091-40-23021910 091-40-23021954	PURCHASE DEPARTMENT			
GSTIN:		Enq/Collective No :E5A1V04433	Enq.Dt : 17.03.2022	No.Of Items :*	DUE Dt. OF QUOTN : 07.04.2022	

Office Copy

Please submit your lowest quotation in sealed cover superscribed with Enquiry No./Collective No.(RFQ No) and due date subject to our terms and conditions attached ,for the materials mentioned below.Your offer has to reach us onor before due date by 11.00 Hours (IST) and will be opened at 14.00 Hours.(IST).If our Enquiry No./Collective No.(RFQ No) and tender due date are not super scribed on the tender cover , your offer shall be summarily rejected. Incomplete offers and late offers will not be considered.

SL NO	Purchase Req.no	item no	Material Code, HSN No.	Drg no - Ver , Rev & Spec - Ver , Rev,Spec-Var	Description	Unit	Qty	Delivery Date	Schedule Qty
11	8000106382	40	HE9718634185 84199090	31668001789-01,,NA,,	CU-NI CLAD FIX TUBESHEET (OD868X65THK)	KG	2.000	25.08.2022	1.000
12	8000106382	10	84199090					25.08.2022	1.000
13	8000106382	50	HE9718634193 84199090	31668001789-02,,NA,,	CU-NI CLAD FLOAT TUBESHEET(OD790X65THK)	KG	2.000	25.08.2022	1.000
14	8000106382	20	84199090					25.08.2022	1.000

Special Remarks

CheckList of Quality Interventions:

BHEL reserves the right to enforce any or all of the following checks during execution of the order.
There is no additional cost to the vendor on account of these checks.

TEST CERTIFICATE REQD: Y GUARANTEE REQ : Y SAMPLE REQD : N BID TYPE : TWO PART	For and on-behalf of Bharat Heavy Electricals Limited. P Reena Suresh Kumar Manager/Purchase(HE&F)- 04023183530
---	---

S. NO.	TERMS & CONDITIONS	BHEL REQUIREMENT				VENDOR'S CONFIRMATION / REPLY																																																																	
1	NAME & ADDRESS	Name, address, e-mail id, contact no.etc. of entity on whom order to be released in case of L ₁ . The offer should be either from the manufacturer directly or from the authorised agency. In case of BHEL receiving offer from both, then offer from manufacturer will be considered. Offer from unauthorised agency / entity on behalf of any vendor shall be summarily rejected. Note : BHEL shall deal directly with all Indian manufacturers.																																																																					
TECHNICAL TERMS																																																																							
1	DESCRIPTION, SIZE & QUANTITY	<table border="1"> <thead> <tr> <th>Material Code.</th> <th>Material Description</th> <th>Drawing No</th> <th>Qty</th> <th>Package Details</th> </tr> </thead> <tbody> <tr> <td>HE9718634150</td> <td>AL-BRONZE CLAD TUBE SHEET(OD879X175THK)</td> <td>41668006035-01</td> <td>1</td> <td rowspan="3">PACKAGE-1</td> </tr> <tr> <td>HE9718634169</td> <td>AL-BRONZE CLAD TUBE SHEET(OD716X175THK)</td> <td>41668006035-02</td> <td>1</td> </tr> <tr> <td>HE9715464149</td> <td>AL-BRONZE CLAD MOCK UP PIECE(150X150)</td> <td>41668006035-03</td> <td>3</td> </tr> <tr> <td></td> <td>HE9711343118</td> <td>FL TS cladded FRG SA266G2 SA240S32750</td> <td>D41668006079-02</td> <td>2</td> <td rowspan="2">PACKAGE-2</td> </tr> <tr> <td></td> <td>HE9711343100</td> <td>FR TS cladded FRG SA266G2 SA240S32750</td> <td>D41668006079-01</td> <td>1</td> </tr> <tr> <td></td> <td>HE9718633146</td> <td>CU-NI CLAD FIX TUBESHEET (OD681X50THK)</td> <td>31668001789-04</td> <td>1</td> <td rowspan="3">PACKAGE-3</td> </tr> <tr> <td></td> <td>HE9718633154</td> <td>CU-NI CLAD FLOAT TUBESHEET(OD595X50THK)</td> <td>31668001789-05</td> <td>1</td> </tr> <tr> <td></td> <td>HE9718633162</td> <td>CU-NI CLAD TSH MOCK UP(150X150X50THK)</td> <td>31668001789-06</td> <td>3</td> </tr> <tr> <td></td> <td>HE9718634185</td> <td>CU-NI CLAD FIX TUBESHEET (OD868X65THK)</td> <td>31668001789-01</td> <td>2</td> <td rowspan="3">PACKAGE-4</td> </tr> <tr> <td></td> <td>HE9718634193</td> <td>CU-NI CLAD FLOAT TUBESHEET(OD790X65THK)</td> <td>31668001789-02</td> <td>2</td> </tr> <tr> <td></td> <td>HE9714714079</td> <td>CU-NI CLAD TSH MOCK UP(150X150X65THK)</td> <td>31668001789-03</td> <td>6</td> </tr> </tbody> </table>	Material Code.	Material Description	Drawing No	Qty	Package Details	HE9718634150	AL-BRONZE CLAD TUBE SHEET(OD879X175THK)	41668006035-01	1	PACKAGE-1	HE9718634169	AL-BRONZE CLAD TUBE SHEET(OD716X175THK)	41668006035-02	1	HE9715464149	AL-BRONZE CLAD MOCK UP PIECE(150X150)	41668006035-03	3		HE9711343118	FL TS cladded FRG SA266G2 SA240S32750	D41668006079-02	2	PACKAGE-2		HE9711343100	FR TS cladded FRG SA266G2 SA240S32750	D41668006079-01	1		HE9718633146	CU-NI CLAD FIX TUBESHEET (OD681X50THK)	31668001789-04	1	PACKAGE-3		HE9718633154	CU-NI CLAD FLOAT TUBESHEET(OD595X50THK)	31668001789-05	1		HE9718633162	CU-NI CLAD TSH MOCK UP(150X150X50THK)	31668001789-06	3		HE9718634185	CU-NI CLAD FIX TUBESHEET (OD868X65THK)	31668001789-01	2	PACKAGE-4		HE9718634193	CU-NI CLAD FLOAT TUBESHEET(OD790X65THK)	31668001789-02	2		HE9714714079	CU-NI CLAD TSH MOCK UP(150X150X65THK)	31668001789-03	6								
Material Code.	Material Description	Drawing No	Qty	Package Details																																																																			
HE9718634150	AL-BRONZE CLAD TUBE SHEET(OD879X175THK)	41668006035-01	1	PACKAGE-1																																																																			
HE9718634169	AL-BRONZE CLAD TUBE SHEET(OD716X175THK)	41668006035-02	1																																																																				
HE9715464149	AL-BRONZE CLAD MOCK UP PIECE(150X150)	41668006035-03	3																																																																				
	HE9711343118	FL TS cladded FRG SA266G2 SA240S32750	D41668006079-02	2	PACKAGE-2																																																																		
	HE9711343100	FR TS cladded FRG SA266G2 SA240S32750	D41668006079-01	1																																																																			
	HE9718633146	CU-NI CLAD FIX TUBESHEET (OD681X50THK)	31668001789-04	1	PACKAGE-3																																																																		
	HE9718633154	CU-NI CLAD FLOAT TUBESHEET(OD595X50THK)	31668001789-05	1																																																																			
	HE9718633162	CU-NI CLAD TSH MOCK UP(150X150X50THK)	31668001789-06	3																																																																			
	HE9718634185	CU-NI CLAD FIX TUBESHEET (OD868X65THK)	31668001789-01	2	PACKAGE-4																																																																		
	HE9718634193	CU-NI CLAD FLOAT TUBESHEET(OD790X65THK)	31668001789-02	2																																																																			
	HE9714714079	CU-NI CLAD TSH MOCK UP(150X150X65THK)	31668001789-03	6																																																																			
2	MATERIAL SPECIFICATION	<p><u>FOR PACKAGE-1 MATERIAL CODES (HE9715464149, HE9718634150 & HE9718634169)</u></p> <ol style="list-style-type: none"> 1. A) BASE MATERIAL SHALL BE AS PER SA266 GR.2 OF ASME SEC II PART 'A' LATEST EDITION B) CLADDING MATERIAL SHALL BE AS PER SB171 C61300 OF ASME SEC-II PART-B LATEST EDITION. 2. CLADDING SHALL BE INTEGRALLY AND CONTINUOUSLY BONDED TO THE BASE MATERIAL AND CLADDING REQUIRED ON ONE SIDE ONLY 3. BOND BETWEEN CLADDING AND THE BASE METAL SHALL BE CHECKED FOR MINIMUM STRENGTH OF 8.5 KGF/SQ.MM IN SHEAR BY CONDUCTING SHEAR TEST 4. CLAD PLATE SHALL BE ULTRASONICALLY EXAMINED FROM THE CLAD SURFACE AS PER SA 578. SCANNING SHALL BE 100% OF THE PLATE SURFACE. ACCEPTANCE STD SHALL BE LEVEL-A OF B432 5. BASE FORGING MATERIAL TO BE SUPPLIED IN NORMALIZED & TEMPERED CONDITION AND CARBON CONTENT SHALL NOT BE GREATER THAN 0.25% 6. BASE FORGING SHALL BE ULTRASONICALLY EXAMINED TESTED AS PER SA 388 OF ASME SEC –II PART 'A' LATEST CODE AND ADDENDA, ACCEPTANCE STANDARD SHALL BE AS PER CLAUSE 3.3.4 OF ASME SECTION VIII DIV-2 CODE & ADDENDA 7. BASE MATERIAL TO BE CHARPY V-NOTCH IMPACT TESTED AND MINIMUM IMPACT ENERGY REQUIRED FOR AVERAGE OF 3 SPECIMENS SHALL BE 20J. MINIMUM IMPACT ENERGY PERMITTED IS 16J FOR ONE SPECIMEN ONLY OF A SET. IMPACT TEST TEMPERATURE SHALL BE -46 OC 8. FLATNESS ON THE CLADDED SURFACE SHOULD BE LIMITED TO 1 MM ON ENTIRE SURFACE OF TUBE PLATE. 9. THE TOLERANCE ON MATERIAL SHALL BE LIMITED TO +2.0MM, -0.0MM <p><u>FOR PACKAGE -2 MATERIAL CODES (HE9711343118 & HE9711343100)</u></p> <ol style="list-style-type: none"> 1. A) BASE MATERIAL SHALL BE AS PER SA266 GR.2 OF ASME SEC II PART 'A' LATEST EDITION INCLUDING NACE MR0103 REQUIREMENT B) CLADDING MATERIAL SHALL SUPER DUPLEX STAINLESS STELL(SA240 S32750) AND SHALL CONFIRM SA-264 OF ASME SEC-II PART-A LATEST EDITION. 2. THE TOLERANCE ON MATERIAL SHALL BE LIMITED TO +1.0MM, -0.0MM 3. CLADDING SHALL BE INTEGRALLY AND CONTINUOUSLY BONDED TO THE BASE MATERIAL AND CLADDING REQUIRED ON ONE SIDE ONLY 4. BASE FORGING SHALL BE ULTRASONICALLY EXAMINED TESTED AS PER SA 388 OF ASME SEC –II PART 'A' LATEST 5. CLAD PLATE SHALL BE ULTRASONICALLY EXAMINED FROM THE CLAD SURFACE AS PER SA 578. SCANNING SHALL BE 100% OF THE PLATE SURFACE. ACCEPTANCE STD SHALL BE LEVEL-C 6. BOND BETWEEN CLADDING AND THE BASE METAL SHALL BE CHECKED FOR MINIMUM STRENGTH OF 14 KGF/SQ.MM IN SHEAR BY CONDUCTING SHEAR TEST. 7. BASE FORGING MATERIAL TO BE SUPPLIED IN NORMALIZED & TEMPERED CONDITION AND CARBON CONTENT SHALL NOT BE GREATER THAN 0.25%. 8. FLATNESS ON THE CLADDED SURFACE SHOULD BE LIMITED TO 1 MM ON ENTIRE SURFACE OF TUBE PLATE. THE SAME SHOULD BE INSPECTED AND CERTIFIED BY BHEL TPIA. 9. BASE MATERIAL SHALL CONFIRM TO NACE MR0103 REQUIREMENTS. <p><u>FOR PACKAGE-3 & 4 MATERIAL CODES (HE9718633146, HE9718633154, HE9718633162, HE9718634185, HE9718634193 & HE9714714079)</u></p> <ol style="list-style-type: none"> 1. A) BASE MATERIAL SHALL BE AS PER SA266 GR.2 OF ASME SEC II PART 'A' LATEST EDITION B) CLADDING MATERIAL SHALL BE AS PER SB171 C71500 OF ASME SEC-II PART-B LATEST EDITION. 2. CLADDING SHALL BE INTEGRALLY AND CONTINUOUSLY BONDED TO THE BASE MATERIAL AND CLADDING REQUIRED ON ONE SIDE ONLY 3. BOND BETWEEN CLADDING AND THE BASE METAL SHALL BE CHECKED FOR MINIMUM STRENGTH OF 8.5 KGF/SQ.MM IN SHEAR BY CONDUCTING SHEAR TEST 4. CLAD PLATE SHALL BE ULTRASONICALLY EXAMINED FROM THE CLAD SURFACE AS PER SA 578. SCANNING SHALL BE 100% OF THE PLATE SURFACE. ACCEPTANCE STD SHALL BE LEVEL-A OF B432 5. BASE FORGING MATERIAL TO BE SUPPLIED IN NORMALIZED & TEMPERED CONDITION AND CARBON CONTENT SHALL NOT BE GREATER THAN 0.25% 6. BASE FORGING SHALL BE ULTRASONICALLY EXAMINED TESTED AS PER SA 388 OF ASME SEC –II PART 'A' LATEST CODE AND ADDENDA, ACCEPTANCE STANDARD SHALL BE AS PER CLAUSE 3.3.4 OF ASME SECTION VIII DIV-2 CODE & ADDENDA 7. BASE MATERIAL TO BE CHARPY V-NOTCH IMPACT TESTED AND MINIMUM IMPACT ENERGY REQUIRED FOR AVERAGE OF 3 SPECIMENS SHALL BE 20J. MINIMUM IMPACT ENERGY PERMITTED IS 16J FOR ONE SPECIMEN ONLY OF A SET. IMPACT TEST TEMPERATURE SHALL BE -46 OC 8. FLATNESS ON THE CLADDED SURFACE SHOULD BE LIMITED TO 1 MM ON ENTIRE SURFACE OF TUBE PLATE. 9. THE TOLERANCE ON MATERIAL SHALL BE LIMITED TO +2.0MM, -0.0MM 																																																																					

S. NO.	TERMS & CONDITIONS	BHEL REQUIREMENT	VENDOR'S CONFIRMATION / REPLY
3	DRAWING	<p><u>FOR PACKAGE-1 MATERIAL CODES (HE9715464149, HE9718634150 & HE9718634169)</u> ALL DIMENSIONAL DETAILS AND TECHNICAL REQUIREMENTS SHALL BE AS PER DRG. NO. 41668006035 REV 00.</p> <p><u>FOR PACKAGE -2 MATERIAL CODES (HE9711343118 & HE9711343100)</u> ALL DIMENSIONAL DETAILS AND TECHNICAL REQUIREMENTS SHALL BE AS PER DRG. NO. 41668006079 REV 00</p> <p><u>FOR PACKAGE-3 & 4 MATERIAL CODES (HE9718633146, HE9718633154, HE9718633162, HE9718634185, HE9718634193 & HE9714714079)</u> ALL DIMENSIONAL DETAILS AND TECHNICAL REQUIREMENTS SHALL BE AS PER DRG. NO 3-16680-01789 REV.00</p>	
4	QUALITY PLAN	<p><u>FOR PACKAGE-1 MATERIAL CODES (HE9715464149, HE9718634150 & HE9718634169)</u> QP NO: HY/QA/VSQP/TCMO/009/CLAD/ W-1032608900 SHALL BE FOLLOWED.</p> <p><u>FOR PACKAGE -2 MATERIAL CODES (HE9711343118 & HE9711343100)</u> ALL REQUIREMENTS AS PER QP. NO: HY/QA/VSQP/TCMO/009/ DUPLEX CLAD SHALL BE MET.</p> <p><u>FOR PACKAGE-3 & 4 MATERIAL CODES (HE9718633146, HE9718633154, HE9718633162, HE9718634185, HE9718634193 & HE9714714079)</u> QUALITY & INSPECTION REQUIREMENTS SHALL BE AS PER QP NO: HYQA/VSQP/2017-18/HE/120/M-HN-1011BARAUNI REV.00</p> <p>NOTE: L1 vendor shall submit Quality plan for approval within 7 days of PO receipt. BHEL shall furnish approval/comments on submitted Quality plan with in 10 days of quality plan submission.</p>	
5	INSPECTION & CERTIFICATION	<p>Indian Vendors: By BHEL or BHEL TPIA as per Quality Plan.</p> <p>Note: Vendors are advised to raise Inspection Call in CQIR system (www.cqir.bhel.in) with Purchasing Unit as 'HPEP' at least 3 working days prior to the proposed date of inspection.</p>	
Commercial Terms			
1	TERMS OF DELIVERY	FOR BHEL RC Puram Stores for Indian Vendors.	
1A	FOR BHEL price / Delivery implies	<p>a) Freight & Insurance (F&I) are in vendor's scope and price quoted is inclusive of F & I.</p> <p>b) C-Note date or Date of submission of documents whichever is later shall be considered as delivery date incase documents are not submitted within 10 days from the dispatch of the material.</p>	
2	PACKING & FORWARDING	P & F charges shall be inculsive of the quoted price.	
3	FREIGHT & INSURANCE	By Supplier upto delivery point.	
4	THIRD PARTY INSPECTION & CERTIFICATION CHARGES	BHEL TPI inspection charges by BHEL. Vendor's offer will be loaded by appropriate percentage for evaluation. Currently it is 0.26%.	
6	DELIVERY PERIOD	<p>16 weeks from PO date for all Packages</p> <p>Note:Delivery quoted beyond 16 weeks period will attract loading of 0.5% per week for evaluation of offer. However, BHEL reserves the right to reject the offers with delivery period not meeting the tender stipulated delivery schedule.</p>	
7	MSE CLAUSE	"MSE suppliers can avail the intended benefits only if they submit UDYAM REGISTRTRION CERTIFICATE along with the offer. Non submission of the same will lead to consideration of their bid at par with other bidders. No benefit shall be applicable for this enquiry if any deficiency in the above required document is not submitted before price bid opening. If the tender is to be submitted through E-Procurement portal, then the above required documents are to be uploaded on the portal."	
8	Two - PART BID	Offer shall be submitted in two part bid system thru' EPS. Part-I shall consists of Techno-Commercial bid with all required documents and Price shall be fed in Part-II.	
9	TECHNO-COMMERCIAL BID	<p>Techno-Commercial Bid shall essentially consist of:</p> <p>(i) Duly filled in Pre-Qualification Criteria (PQC) along with all supporting documents & duly filled up Annexure - 1.</p> <p>(ii) Duly filled in signed copy of Special Contract Conditions (SCC).</p> <p>(iii) Duly filled in signed copy of Instructions to Bidder (ITB).</p> <p>(iv) Signed & stamped copy of Drawing & QP</p> <p>(v) Udyam Registration Certificate, if applicable (for MSE vendors).</p> <p>(vi) Annexure - II (Non Disclosure Agreement)</p> <p>(vii) Annexure - III (Local Content Certificate),If Applicable</p> <p>(viii) Annexure - IV, If Applicable</p> <p>All the above documents shall be duly authenticated by signature & official stamp on each page.</p> <p>Note: Bid shall be complete in all respects including all the documents / information required for techno-commercial evaluation. Incomplete offers shall be liable to rejection.</p>	
9B	PRICE BID	Quoted price shall be firm basis. Vendor shall quote rate per piece.	
10	EVALUATION OF L1 BIDDER	Evaluation of offer will be on Package wise lowest destination cost to BHEL basis.	

S. NO.	TERMS & CONDITIONS	BHEL REQUIREMENT	VENDOR'S CONFIRMATION / REPLY
12	GUIDELINES REGARDING DEALINGS WITH INDIAN AGENTS OF FOREIGN SUPPLIERS	<p>BHEL shall deal directly with foreign vendors, wherever required, for procurement of goods. However, if the foreign principal desires to avail of the services of an Indian agent, then the foreign principal should ensure compliance to regulatory guidelines - which require mandatory submission of an Agency Agreement.</p> <p>It shall be incumbent on the Indian agent and the foreign principal to adhere to the relevant guidelines of Government of India, issued from time to time.</p> <p>The Agency Agreement should specify the precise relationship between the foreign OEM / foreign principal and their Indian agent and their mutual interest in the business. All services to be rendered by agent/ associate, whether of general nature or in relation to the particular contract, must be clearly stated by the foreign supplier/ Indian agent. Any payment, which the agent or associate receives in India or abroad from the OEM, whether as commission or as a general retainer fee should be brought on record in the Agreement and be made explicit in order to ensure compliance to laws of the country.</p> <p>Any agency commission to be paid by BHEL to the Indian agent shall be in Indian currency only.</p> <p>Tax deduction at source is applicable to the agency commission paid to the Indian agent as per the prevailing rules.</p> <p>In the absence of any agency agreement, BHEL shall not deal with any Indian agent (authorized representatives / associate / consultant, or by whatever name called) and shall deal directly with the foreign principal only for all correspondence and business purposes.</p> <p>The "Guidelines for Indian Agents of Foreign Suppliers" enclosed at annexure -'A' shall apply in all such cases.</p> <p>The supply and execution of the Purchase Order (including indigenous supplies/ service) shall be in the scope of the OEM/ foreign principal. The OEM/ foreign principal should submit their offer inclusive of all indigenous supplies/ services and evaluation will be based on 'total cost to BHEL'. In case OEM/ foreign principal recommends placement of order(s) towards indigenous portion of supplies/ services on Indian supplier(s)/ agent on their behalf, the credentials/ capacity/ capability of the Indian supplier(s)/ agent to make the supplies/ services shall be checked by BHEL as per the extant guidelines, before opening of price bids. In this regard, details may be checked as per Annexure-B (copy enclosed). It will be the responsibility of the OEM/ foreign principal to get acquainted with the evaluation requirements of Indian supplier/ agent as per SEARP available on www.bhel.com.</p> <p>As per directives of CENTRAL VIGILANCE COMMISSION, GOVERNMENT OF INDIA, one agent can not represent two or more suppliers or quote on their behalf in a particular tender. If so found at any stage, BHEL Hyderabad is likely to cancel Enquiries / POs to such suppliers. Further, such Indian Agent is likely to be de-listed (Black listed for business from BHEL).</p>	
13	END CUSTOMER APPROVAL	Credentials of techno-commercially qualified bidders may be forwarded to end customer for their review and approval, inline with clause 7 of PQC. Price bids of techno-commercially qualified bidders will be opened, subjected to approval of end customer.	
14	GUARANTEE	Guarantee on the supplier for a period of 18 months from the date of dispatch or 12 months from the date of commissioning whichever is earlier.	
15	EARNEST MONEY DEPOSIT (EMD)	EMD charges not applicable for quoting against this tender.	
16	FINANCIAL STANDING	Vendor to submit annual Financial Turnover during the Past 3 Years along with copy of 3 years Audited Balance Sheet.	
17	PURCHASE PREFERENCE TO MSE SUPPLIER	If MSEs quoted price is within the price band of L1+15%, then L1 price shall be counter-offered to MSE vendor (if L1 is other than MSE) for supplying at least 25% of tendered value as per MSME Order dated 09.11.2018. In present case, 50% quantity of each package shall be counter offered to MSE vendors whose price is within purchase preference of 15%.	
18	ONLINE SUPPLIER REGISTRATION POTRAL	Vendors who are new and also not registered with Product Material Directory (PMD) D.CP.001 in BHEL - HPEP, RC Puram, are advised to register against above said PMD through online vendor registration portal available in BHEL website (www.bhel.com).	
19	TERMS & CONDITIONS	Vendor is requested to furnish all details of the offer in this format. In case of any discrepancy between information furnished here and those furnished elsewhere in the bid, the information furnished in this document only shall be considered, and those furnished else where shall be ignored.	

(Attachment to Enquiry No. E5A1V04433 Due on Date 07.04.2022 for submission by 11.00 hrs to open from 14:00 hrs.)					
INSTRUCTIONS TO BIDDER (ITB)					
NOTE: Bidder to confirm in affirmative by typing "YES" or "Applicable Data" in the response column. Deviations , if any shall be recorded in deviations/comments column (Separate sheet can be attached if needed). Non-Deviatable clauses are indicated as "Non-Deviatable".					
S. No.	DETAILED TERMS & CONDITIONS	VENDOR RESPONSE (YES/NO)	DEVIATIONS / COMMENT		
1	SCOPE OF SUPPLY:				
	Signed & Sealed offers are invited for the Scope of Supply of goods and Services or both as detailed in the enquiry. Relevant enclosures/supporting documents / catalogue, if any shall be enclosed to the technical offer. Bidder can also submit offer through email at their own risk. The offer is to be submitted in two parts. Technical offer to be submitted to mail ID technicalbid_hyd@bhel.in , and price bid to be submitted to mail ID pricebid_hyd@bhel.in as an attachment only. Interchanging the information in the mails may lead to rejection of the offer. Supplier shall have no claim on e-mail offers sent on any other e-mail ID. In case of e-mail offers, the mail subject should contain Enquiry No. Due date and Supplier name, Supplier address including contact details shall be mentioned in the content of the mail. Without these details offer is liable for rejection.				
2	GENERAL INSTRUCTIONS:				
A	The quotation should be neatly typed and free from over writing/ erasures. Any correction or addition must be authenticated. The offer including annexures and brochures should be submitted in English / Hindi. All Pages of Techno Commercial Bids (Main Pages), ITB should be signed and Stamped. If there is a conflict in case of bilingual submission, the submission in English will be final.		Non-Deviatable		
B	In case of Single-Part bid Tender, the complete bid shall be submitted in a single sealed cover super subscribing the Tender number and due date. Incomplete offers are liable for rejection. E mail bids shall be sent to mail ID pricebid_hyd@bhel.in as an attachment only.		Non-Deviatable		
C	Bidders to please note that the Terms & conditions contained in this document and Special conditions, if any, are to be read fully before submission of quotations.		Non-Deviatable		
D	Vendors are advised to comply with specific conditions of the enquiry, Should there be any deviations (where deviations are permitted), it shall be entered in the deviation column. BHEL reserves the right to reject such offers or load the bid suitably for evaluation.		Non-Deviatable		
E	Offers shall be submitted directly, only by the vendor or by their authorized representative / agent and the offer should be in line with the regulatory guidelines (i.e A valid Agency agreement between principal vendor and agent / representative shall be attached and the agreement shall cover the scope of services rendered by Agent, Agency Commission and any other information called for as per the regulatory guidelines). OEM / Mill details shall be provided if supplier is not a manufacturer. Bid envelops shall bear the name of Supplier. In case of submission through authorized representative/agent, the name of representative/agent should also be mentioned apart from supplier name.		Non-Deviatable		
F	Offer received after the specified time and date of submission shall be rejected. No further correspondence shall be entertained.		Non-Deviatable		
G	Unsolicited offers shall not be considered.		Non-Deviatable		
3	OTHER PARTICULARS (Please indicate applicable data)				
A	Name of the Bid currency (freely tradable foreign currency for imports and Indian Rupees for indigenous purchase).				
B	Name of the Port of loading and Port of Discharge (applicable to imports).				
4	BID SUBMISSION PROCEDURE:				
A.	For Single Part Bids: Offers addressed to DGM/CMM, Vendor Complex, BHEL, Hyderabad must be sent in a sealed cover on which tender enquiry number and the due date shall be super subscribed and sent by appropriate mode to above address or dropped in tender box located at vendor complex on or before the specified time and date of submission of offers, preferably in the bidder's envelope. For e-mail offers please follow the procedure mentioned in 2 (B).		Non-Deviatable		

(Attachment to Enquiry No. E5A1V04433 Due on Date 07.04.2022 for submission by 11.00 hrs to open from 14:00 hrs.)			
INSTRUCTIONS TO BIDDER (ITB)			
S. No.	DETAILED TERMS & CONDITIONS	VENDOR RESPONSE (YES/NO)	DEVIATIONS / COMMENT
B.	For two-Part Bids:		
i	<p>Two part bid consisting of</p> <p>i) Techno-commercial Bid - (Part-I), with all technical specification & scope including bill of material etc., EMD (where applicable) and unpriced bid with all applicable Commercial Terms and Conditions, rates of agency commission , duties, taxes and other charges, except the price, super scribing enquiry No. (Techno-Commercial Bid) and due date Signed and Stamped ITB and special conditions of contract, if any is required to be attached along with Techno-commercial Bid - (Part-1) AND</p> <p>ii) Price Bid (Part-II), containing ONLY the price (including agency commission, if any) and the applicable duties/taxes/other charges shall be kept in a separate sealed cover super subscribing Enquiry no. (Price bid) & due date. Both these covers shall be kept in a Third cover super subscribing Enquiry no. & due date. All techno commercial terms & conditions mutually agreed prior to price bid opening shall prevail and supersede any terms and conditions specified otherwise in price bid.</p>		Non-Deviatable
ii	Techno-commercial Bid will be opened on the assigned date .Only the price bids of vendors whose techno commercial bids are accepted will be opened later on a specified date.		Non-Deviatable
iii	The bidders whose bids are techno commercially not accepted will be informed & EMD (Earnest Money Deposit) shall be returned wherever submitted.		
iv	Bidders will be allowed to submit the impact on their quoted prices due to changes in technical scope, specifications, and commercial terms/conditions as specified in NIT which in the opinion of BHEL warrant changes in prices.		Non-Deviatable
v	Bids shall be opened on due time and date in the presence of bidders who may like to be present. Only one representative of each bidder shall be permitted to attend the bid opening.		Non-Deviatable
5	Delivery Instructions		
A	Indigenous Purchase		
	Goods shall be delivered on FOR Destination basis to the named destination(s) or as specified in the enquiry, Insurance in the scope of supplier.		
B.	Imports		
	The goods shall be delivered on CIP-basis to port of discharge as mentioned in the purchase order.		
6	Documentation:		
A	Indigenous Purchase		
	<p>Seller shall arrange to send to BHEL, Hyderabad along with all the required documents as detailed in Purchase Order, such as, Tax Invoice (Original for Recipient, Duplicate for Transporter), consignee copy of LR, Packing list , Pre-dispatch Inspection report, Test/ Guarantee/ Warranty certificate/ O&M manuals (as applicable) etc. immediately on dispatch of the goods. Any addition/ exclusion to such documents shall be as specified in the Purchase Order.</p> <p>In case of dispatches from vendor works to site, material receipt certified by site office / Customer shall be provided.</p> <p>Softcopies of the above documents shall be uploaded in Pradan portal https://web.bhelhyd.co.in/mm/ immediately after dispatch of the material.</p>		Non-Deviatable
B	Imports		
	<p>i) Seller shall inform the purchaser the readiness of material along with packing details well in 30 days advance from the date of delivery. Seller shall also upload soft copy of the dispatch documents consisting of BL / AWB, Invoice, Shipping list & Test certificates and other documents as specifically indicated in the Purchase Order in PRADAN Portal (https://web.bhelhyd.co.in/mm/) within 3 days from the B/L date for sea shipment and 1 day from AWB date for Air shipment.</p>		
	ii) In case of CIP shipments, seller shall also inform purchaser the information about discharge port agent details and ship arrival information within 7 working days from the date of Shipment.		

(Attachment to Enquiry No. E5A1V04433 Due on Date 07.04.2022 for submission by 11.00 hrs to open from 14:00 hrs.)

INSTRUCTIONS TO BIDDER (ITB)

S. No.	DETAILED TERMS & CONDITIONS			VENDOR RESPONSE (YES/NO)	DEVIATIONS / COMMENT
	<p>iii) In case the material shipped in Full Containers(FCL), Seller shall ensure that the Bill of Lading should clearly spell out the following</p> <ol style="list-style-type: none"> 1. Port of discharge -- "Nhavaseva"/chennai 2. Place of Delivery / Final Destination - "ICD Sanath Nagar". 3. For air consignment the port of discharge will be Hyderabad, India and consignee shall be BHEL. 				
	<p>iv) In case of Air shipment, the following dimensions of single package may be noted.</p> <ol style="list-style-type: none"> a). Dimension of the cargo(ODC) -- > 125" x 88" x 63" b).Weight of the cargo -- >3.5 MT. <p>If any package dimension or weight crosses the above set limits, it will be treated as Over Dimension Cargo (ODC) or Over Weight Cargo and seller shall inform BHEL well in advance of 20 days prior to the delivery date to enable BHEL to finalize the freight forwarder</p>				
	<p>(v). Recovery charges for non-submission of documents :</p> <p>Seller shall submit all the required documents to BHEL as prescribed in the Purchase order and NIT.</p> <p>If BHEL incurs any charges such as Penalty, demurrage, container detention, wharf age, storage, Ground rent etc., due to non - compliance / non - submission of documents prescribed in Purchase Order/Tender Document/Letter of credit , the same shall be recovered from the seller as under:</p> <ol style="list-style-type: none"> 1. EUROPE/USA/Black Sea/ Far East/Middle East/South East sector A. For EX-WORKS / FCA/ FAS / FOB Sea Consignments: <p>Penalty for late submission / negotiation of documents beyond 14 days shall be as under:</p>				
	Sl. No	Period (From Date of Bill of Lading)	Recoverable Charges	Recoverable Charges per day per container	
			LCL per week/ Break bulk cargo per day	20FT Container	40FT Container
	i	Upto 14th day	Nil	Nil	Nil
	ii	15th day onward	USD 10	USD 50	USD 105
	<p>B. For CIF / CFR / CIP / CPT Sea Shipments:</p> <p>For CIF / CFR / CIP / CPT Sea Shipments, Vendor shall provide rates for detention charges after free period at the time of offer itself in case of engagement of 20FT Container and 40FT category. In case of late presentation of documents to the bank recovery will be effected from the Vendor as per the rates quoted by the Vendor at the time of offer in this regard.</p> <p>In case of Break bulk cargo and LCL Demurrage/storage charges shall be recovered at rate of USD 10 per day and storage charges rate of USD 10 per week respectively shall be charged as late presentation charges.</p>				
	<p>(vi) Description of items in invoice, packing list, BL / AWB or LR shall be same as PO item description. Vendors shall ensure that invoice shall contain PAN nos. of both seller and buyer related numbers. BHEL PAN AAACB4146P and BHEL TAN HYDB00086C.</p> <p>Any other additional documents sought by the statutory authorities, the same shall be produced by the seller on priority basis.</p>				
	<p>(vii) Seller shall provide package details including number of packages, gross weight, net weight etc.</p>				
	<p>(viii) The seller shall provide the following documents at the time of submission of offer :</p> <ol style="list-style-type: none"> a) No Business Connection in India declaration issued by the seller as per the format specified. (or) b) (i) No Permanent Establishment in India declaration issued by the seller as per the format specified. (ii) Tax Residence Certificate issued by the seller's tax authorities. (iii) Form 10F issued by the supplier. c) In case the seller has a Business Connection in India as per Section 9 of Income Tax Act or Permanent Establishment in India as per Article 5 of Double Taxation Avoidance Agreement India and the seller's country, the seller shall provide a withholding tax order issued by the Indian Income Tax authority for recovery of applicable tax. 				

(Attachment to Enquiry No. E5A1V04433 Due on Date 07.04.2022 for submission by 11.00 hrs to open from 14:00 hrs.)			
INSTRUCTIONS TO BIDDER (ITB)			
S. No.	DETAILED TERMS & CONDITIONS	VENDOR RESPONSE (YES/NO)	DEVIATIONS / COMMENT
7	Delivery Schedule		
A	The tendered goods shall be delivered within the period stipulated in PO . Delivery at BHEL can be accepted at the earliest, 30 days prior to delivery date as mentioned in the Purchase order. Delivery earlier than 30 days of contractual delivery date may be accepted with the written permission of BHEL -Purchase department. Goods arriving after the delivery date will be accepted only with the prior written permission of BHEL otherwise they will not be allowed inside the factory. BHEL reserves the right to reject the material, if not delivered by scheduled Purchase Order Delivery Date. (In case of imports , the final entry date of Import General Manifest (IGM) will be reckoned as delivery completion date)		Non-Deviatable
B	Documents such as TC,GCs Inspection reports are to be submitted within 10 days of dispatch of these materials. C note date or Date of submission of documents whichever is later shall be considered as delivery date incase documents are not submitted within 10 days from the dispatch of the material. Supply of plant/ equipment/ stores shall not be considered complete until they have been inspected and accepted at the place and destination specified for delivery by the time stipulated under the terms & conditions of the Order/ Contract. Mere payment by itself shall not constitute acceptance of the goods or materials in any manner, whatsoever.		
8	Pricing Terms Prices once quoted shall remain firm and valid during the execution of PO. Offers with PVC will be rejected outright except in cases where specifically called for in the NIT.		Non-Deviatable
9	PRICE VALIDITY : Unless otherwise specified, offer shall be valid for a period of 90 days from the date of bid opening (Technical bid /part-I in case of two part bid). However the prices quoted for spare parts of the Main equipment shall be kept valid for a period of 1 year from the date of Placement of PO for the main equipment.		
10	Taxes & Duties (RATE TO BE INDICATED by the bidder against the space provided)		
A	Indigenous Purchase		
	The Taxes as applicable shall be quoted in the following manner.		
i	Vendor to indicate HSN of Goods or SAC of Services.		
ii	IGST/CGST/SGST/UTGST: Rate of Tax to be quoted as extra in %		
	NOTE: Bidders to ensure correct applicability of IGST/CGST/SGST/UTGST based on the Inter / Intra state movement of goods. Taxes prevalent on the contractual delivery date or the actual delivery date (in case of delay) which ever is lower shall be applicable paid. In case Bidder has opted for GST Composition Scheme, the same may be stated explicitly both in their technical and price bids.		
iii	Any other taxes & duties not covered anywhere above may be indicated separately.		
iv	Taxes deducted at source: TDS as per the extant statute shall be recovered. In case vendor does not provide PAN details/concessional certificates, the TDS deduction shall be at the maximum percentage stipulated as per the provisions of Income Tax Act.		Non-Deviatable
B.	Foreign Purchase (Imports)		
i	The offered price shall be inclusive of all the Taxes and duties as applicable in country of bidder / country of dispatch for the quoted CIP price.		Non-Deviatable
ii	Taxes deducted at source: TDS as per the extant statute shall be recovered. In case vendor does not provide PAN details/concessional certificates, the TDS deduction shall be at the maximum percentage stipulated as per the provisions of Income Tax Act.		Non-Deviatable

(Attachment to Enquiry No. E5A1V04433 Due on Date 07.04.2022 for submission by 11.00 hrs to open from 14:00 hrs.)			
INSTRUCTIONS TO BIDDER (ITB)			
S. No.	DETAILED TERMS & CONDITIONS	VENDOR RESPONSE (YES/NO)	DEVIATIONS / COMMENT
11	Payment Terms: Unless otherwise specified in Special Conditions, following shall be the terms of Payment.		
A	<p><u>Indigenous:</u> 100% payment along with taxes, freight & insurance will be made within 75 days from the date of receipt of complete documentation as per PO. However payment would be done only after receipt of original documents, including site/ Customer acknowledgement on LR (MRC - Material Receipt Certificate at site) / GR clearance at BHEL Stores. For MSEs (covered under MSME Act) which are registered and periodically renewed with BHEL, this period will be 45 days* as prescribed in the relevant act. Adherence to the above time schedule of payment is contingent upon Vendor complying with GST provisions and availment of Input Tax Credit by BHEL before the date of payment. *The taxes that are reimbursed would be the ones applicable as on the contractual Purchase Order delivery date or the amount actually paid whichever is less. In case GST credit is delayed/ denied to BHEL, due to non/delayed receipt of goods and/or tax invoice or expiry of timeline prescribed in GST Law for availing such ITC, or any other reason not attributable to BHEL, GST amount shall be recoverable from Vendor along with interest levied/ leviable on BHEL.</p>		
B	<p><u>Imports:-</u> i) 100% payment (less Indian Agency Commission, if any) shall be paid through “Usance Letter of Credit / Cash Against Documents (CAD) / Wire Transfer” with a credit period of 60 days ii) LC will be opened after successful completion of pre dispatch inspection prior to the scheduled / agreed delivery date LC will be opened within 7 working days from the date of request.</p>		
C	<p>Note: 1) No advance payment is acceptable. However, in exceptional/rare cases, BHEL at its discretion, may consider advance payment against Bank Guarantee valid up to receipt of material at BHEL for 110% of advance amount issued / confirmed by any of the BHEL consortium banks. 2) Wherever EMD (Earnest Money Deposit) is applicable, it may be noted that no interest will be paid on EMD and the EMD will be paid back to unsuccessful bidders within fifteen days after award of the contract. Successful bidder's EMD will be converted to SD (Security Deposit). Tender Cost wherever applicable is not refundable.</p>		Non-Deviatable
D	No interest shall be payable by BHEL on earnest money or security deposit or any money due to the contractor by BHEL.		
12	<p>Penalty clause: In the event of delay in supply of goods, penalty of 0.5% per week or part there of shall be levied on the undelivered portion subject to a maximum of 10% of the order value. Penalty amount so determined along with applicable GST thereon shall be recovered.</p>		
13	Excess materials supplied beyond tolerance limit as specified in PO, will not be accounted for.		Non-Deviatable
14	Rejected materials , if any, shall be collected by the vendor within 90 days of such communication to the vendor .Beyond 90 days a ground rent of 0.25 %of the value of the material per week will be levied for a maximum period of two weeks.. Beyond this period the supplier forfeits their right to the materials.		Non-Deviatable
15	<p>Guarantee / Warranty Period : (Deviation to this clause is not acceptable.) Wherever required, and so provided in the specifications/Purchase Order, the seller shall guarantee that the goods supplied shall comply with the specifications laid down, for materials, workmanship and performance. If within the guarantee period, the delivery is found to be non-complaint, the seller shall on his own account, replace repair, or re-execute the delivery at Purchaser's discretion on the purchaser's first request or within the mutually agreed period, without prejudice to Purchaser's other legal rights. If the seller continues to default on their obligations, purchaser has the right to proceed to replace, repair or re- execute the order at the seller's expense, with or without help from third parties. Purchaser shall notify the seller of the exercise of this right in advance where ever possible Unless otherwise specified, guarantee period shall be 12 months from the date of commissioning or 18 months from the date of supply/replacement whichever is earlier. For bought out packages which are intended to be incorporated in installations or systems the guarantee period shall not start until the time the installations or systems are commissioned, provided always that the period ends not later than 30 months after the date of supply of the goods. The guarantee period shall be extended by the period during which the goods are not in compliance. A guarantee period as described above shall apply afresh to replaced, repaired or re-executed parts of a delivery.</p>		Non-Deviatable

(Attachment to Enquiry No. E5A1V04433 Due on Date 07.04.2022 for submission by 11.00 hrs to open from 14:00 hrs.)

INSTRUCTIONS TO BIDDER (ITB)

NOTE: Deviations (Commercial as well as Technical) from the tender specifications and conditions are generally not acceptable. However, deviation if any, shall be brought out clearly with proper justification in the offer. The deviation, if considered by BHEL, shall be loaded for comparison, while evaluating the offer. If a bidder unconditionally withdraws any deviation before price bid opening, the same shall not be loaded. Loading criteria in respect of major commercial conditions where deviations if any are accepted shall be as per clause No.16.

The Vendors may specifically note the following.

16	Evaluation and Loading Criteria:
A	Evaluation of prices shall be done item-wise unless otherwise specified in the enquiry. Evaluation shall be on the basis of delivered cost, i.e. "total cost to BHEL" w.r.t the finalized technical scope and commercial conditions (after considering incidence of applicable taxes and duties and loading). For evaluation, exchange rate (TT selling rate of State Bank of India) as on the date of bid opening (Part-I, in case of two-part bids) shall be considered. If the relevant day happens to be a bank holiday, then the forex rate as on the previous bank (SBI) working day shall be taken.
B	In case of foreign bidders, the quoted CIP price shall be loaded by the following factors to arrive at the Delivered Cost:
i	- Import duty as applicable at the time of Technical/ Part-I bid opening .
ii	- Port handling/ clearing charges & inland freight and insurance: @ 5% of CIP value (10% for plates, pipes & structurals).
iii	In other cases subject to acceptance by BHEL, loading for various factors (in addition to above) as the case may be will be done as follows: 0.5% for unloading at Port of Destination Marine Freight 4% and Marine Insurance 1% (9% and 1% towards Freight and Insurance respectively for Plates, Pipes, Rounds & Structurals)
C	In case of Indigenous Bidders, Ex-works offers received (as against FOR Destination mentioned in enquiry) shall be loaded by 4% of Ex-works value (9% for plates, pipes, rounds & structurals) unless otherwise mentioned in enquiry.
D	Deviated Penalty: Any loading on penalty clause shall be 10% or to the extent to which the vendor has opted for deviation.
E	Deviated Payment Terms: Terms: In case BHEL considers any deviation in payment terms, the bids shall be loaded with 18% interest per annum to the extent of deviation.
17	Procurement directly from the manufacturers/ suppliers shall be preferred. However, no agent shall be allowed to represent more than one manufacturer/ supplier in the same tender. Moreover, either the agent could bid on behalf of the manufacturer/ supplier or the manufacturer / supplier could bid directly but not both. In case bids are received from both from the manufacturer/ supplier and the agent, bid received from the agent shall be ignored.
18	RIGHT OF REJECTION /NON- PLACEMENT OF PO: BHEL reserves the right to accept or reject any or all bid/s in full or part without assigning any reason whatsoever.
19	INTEGRITY PACT Vendors shall have to enter into Integrity Pact with BHEL as per attachment - for order value of rupees five crores and above and shall be signed by the competent authority before the issue of purchase order, failing which vendor's offer will be rejected.
20	Public Procurement
A	Make in India For this Procurement , the local content to categorize a supplier as a Class I local supplier / Class II local supplier / Non-Local supplier and purchase preference to Class I local supplier , is as defined in Public Procurement (Preference to Make in India) , Oct 2017 dated 04.06.2020 issued by DPIIT . In case of subsequent orders issued by the nodal ministry , changing the definition of local content for the items of the NIT , the same shall be applicable even if issued after issue of this NIT , but before opening of Part– II bids against this NIT. Proforma for self certification for minimum local content and auditor's certification is given in Annexure III .
B	Any Bidder from a country which shares a land border with India will be eligible to bid in this tender only if the bidder is registered with competent authority . https://www.mea.gov.in/ to be referred for latest details of competent authority and exemptions. Proforma for self certification for compliance is given in Annexure IV
21	Benefits earmarked for Purchase from Micro & Small Enterprises (MSEs) – Indigenous Purchase
21A	All Micro and Small Enterprises (MSEs) as defined in MSE Procurement Policy are exempt from Paying earnest money deposit . NSIC registered unit bidders shall submit NSIC Certificate along with bid documents. Date to be reckoned for determining the deemed validity will be the last date of Technical bid submission. Non- submission of such document will lead to consideration of their bid, at par with other bidders and MSE status of such bidders shall be shifted to Non- MSE Category till the supplier submits these documents
21B	In tender,if MSEs quoting price within price band of L1+15% shall also be allowed to supply a portion of requirement by bringing down their price to L1 price in a situation where L1 price is from someone other than a MSE and such MSE shall be allowed to supply up to 25% of total tendered value. In case of more than one such MSE, the supply shall be shared proportionately. Out of these 25% minimum 3% shall be earmarked for MSEs owned by women and 6.25% for MSEs owned by SC/STs who submit the bid along with relevant documents. This is applicable in case of item-level evaluation tenders and divisible tenders .

(Attachment to Enquiry No. E5A1V04433 Due on Date 07.04.2022 for submission by 11.00 hrs to open from 14:00 hrs.)	
INSTRUCTIONS TO BIDDER (ITB)	
21C	If an enterprise falling under MSME category as defined in the Act, graduates to a higher category from its original category or beyond the purview of the Act, it shall continue to avail all non-tax benefits of its original category notified by the Ministry of Micro, Small and Medium Enterprise for a period of three years from the date of such graduation to the higher category.
21D	BHEL HPEP is registered with RXIL (TReDS) platform. MSE bidders are requested to get registered with RXIL (TReDS) platform to avail the facility as per the GOI guidelines
22	Startups : For Startups Medium Enterprises, Condition of prior turnover and prior experience in Public Procurement may be relaxed subject to meeting of Quality and Technical Specifications . Startups are exempt from paying earnest money deposit.
23	For Claiming Payments for goods received at BHEL works / Site from Vendors' Works) a) Original of Invoice marked as ORIGINAL FOR RECIPIENT b) Duplicate of Invoice marked as DUPLICATE FOR TRANSPORTER c) Packing List - clearly showing number of packages, gross weight and net weight. d) Warranty/Guarantee certificates (If applicable as per PO terms) e) Insurance certificate f) Third Party Inspection Certificates. g) LR Copy signed & stamped by Site incharge / Customer for site deliveries) (For material received at BHEL payment will be made against GR for accepted quantity)
24	Inspection Measuring and Test Equipment (IMTE) whether used by the Seller/ Contractor or sub-contractor shall be calibrated, maintained and controlled. Calibration shall be valid and IMTE maintained in sound condition during usage.
25	ISO-9001, ISO14001 and OHSAS 18001 shall be complied
26	Applicable Conditions :These General conditions of Contract for Purchase apply to all enquiries, tenders, request for quotations, orders and agreements concerning the supply of goods and the rendering of related services (hereinafter referred to as “deliverables”) to Bharat Heavy Electricals Limited, Ramachandrapuram , Hyderabad (hereinafter referred to as “BHEL” or the Purchaser) or its projects/customers. Any deviations from or additions to these General conditions of contract for Purchase’ require Purchaser’s express written consent. The general terms of business or sale of the Seller shall not apply to Purchaser. Orders, agreements and amendments thereto shall be binding if made or confirmed by the Purchaser in writing. Only the Purchasing department of the Purchaser is authorized to issue the Purchase order or any amendment thereof.
27	Being PMD Vendor, if you are not quoting against this tender enquiry, please send your regret letter positively for our reference with valid reasons for not participating in the tender enquiry. Repeated lack of response on the part of bidder may lead to deletion such PMD vendor from BHEL's approved vendor list. Vendor shall ensure that PAN details are available/updated with BHEL, else Vendor shall attach PAN details with enquiry failing which offer shall be liable for rejection.
28	Kindly quote your prices in figures and words both. In case of any discrepancy in value, the prices quoted in words shall be considered for evaluation and establishing L1 Status
29	Any discount / revised offer / bids submitted by a bidder on its own shall be considered, provided it is received on or before the due date and time of offer / bid submission (Part-1). Conditional discounts shall not be considered for evaluation of tenders.
30	The bidder whose bid is technically not accepted will be informed & EMD wherever submitted shall be returned after finalization of contract. EMD shall be forfeited in the event of bidder opting out after tender opening.
31	In case of abnormal delays (beyond the maximum late delivery period as per Penalty clause) in supplies / defective supplies or non-fulfillment of any other terms and conditions given in Purchase Order, BHEL may cancel the Purchase Order in full or part thereof, and may also make the purchase of such material from elsewhere / equivalent market price at the risk and cost of the supplier. BHEL will take all reasonable steps to get the material from alternate source at optimum cost. If bidder does not agree to the above Risk Purchase Clause, BHEL reserves the right to reject the offer. Nonperformance of contract attracts penal provisions inline with BHEL's Suspension of Business dealings.
32	Any other terms and conditions of the bidder attached / referred against the tender enquiry will not be considered.
33	All drawings as also all patterns and tool supplied by BHEL or made at BHEL's expense are BHEL's property. These cannot be used or referred to any other party and must only be used in the execution of BHEL's orders.
34	Any amount payable by the consignor / supplier under any of the condition of this contract shall be liable to be adjusted against any amount payable to the consignor / supplier under any other work / contract awarded to him. This is without prejudice to any other action as may be deemed fit by BHEL.
35	The bids of the bidders who are on the banned list and also the bids of the bidders, who engage the services of the banned firms, shall be rejected. The list of firms banned by BHEL is available on BHEL web site www.bhel.com
36	Definitions
Throughout these conditions and in the specifications, the following terms shall have the meanings assigned to them, unless the subject matter or the context requires otherwise.	

(Attachment to Enquiry No. E5A1V04433 Due on Date 07.04.2022 for submission by 11.00 hrs to open from 14:00 hrs.)	
INSTRUCTIONS TO BIDDER (ITB)	
36A	Purchaser' means BHEL-HPEP, Ramachandrapuram, Hyderabad-502 032 of Bharat Heavy Electricals Limited (A Govt. of India Undertaking) incorporated under the companies Act having its registered office at BHEL House, Siri fort, New Delhi-110049, India and shall be deemed to include its successors and assigns. It may also be referred to as BHEL.
36 B	'The seller' means the persons, firm, company or organization on whom the Purchase order is placed and shall be deemed to include the seller's successors, representatives, heirs, executors and administrator as the case may be. It may also be referred to as Contractor, supplier or vendor.
36C	'Contract' shall mean and include the Purchase order incorporating various documents viz., tender/offer, letter of intent/acceptance, the General Conditions of contract and special conditions of contract for Purchase, specifications, inspection/quality plan, schedule of prices and quantities, drawings, if any enclosed are to be provided by the Purchaser or his authorized nominee and the samples or patterns if any to be provided under the provision of the contract. In case of any inconsistency or contradiction between any of the documents, the order of precedence shall be Purchase Order, LOI/LOA followed by specific conditions, special conditions of contract and general conditions of contract for commercial conditions; and specific agreement on technical conditions, special technical conditions and general technical conditions, tender/ offer.
37	'Parties to the contract' shall mean the seller and the purchaser as named in the main body of the Purchase Order.
38	Ordering and confirmation of order
	The seller shall send the order acceptance in Toto within one week from the date of LOI/Purchase order or such other period as specified/agreed by the Purchaser. Purchaser reserves the right to revoke the order placed if the order confirmation differs from the original order placed. Purchaser shall only be legally bound if agreed explicitly in writing to be in agreement with the deviation. The acceptance of deliverables or supplies by Purchaser as well as payments made in this regard shall not imply acceptance of any deviations. The Purchaser order will be deemed to have been accepted if no communication to the contrary is received within one week (or the time limit as specified /agreed by the Purchaser) from the date of P.O. Purchaser, is at liberty to send signed P.O. through electronic media such as e-mail and the receipt of which shall be treated as receipt of order.
39	Execution
	The whole contract is to be executed in the most workman like manner, substantial and approved as per the contracted terms.
40	Progress Report
	The seller shall render such report as to the progress of work and in such form as may be called for by the Purchaser from time to time. The submission and acceptance of such reports shall not prejudice the rights of the purchaser in any manner. Seller shall communicate to BHEL immediately, change of address, ownership, contact person(s), the mobile numbers and e-mail of the dealing person concerned. Milestones shall be periodically updated by vendor/subcontractor through PRADAN Portal (https://web.bhelhyd.co.in/mm/). Non updation will adversely affect service rating of vendor performance.
41	Product information, Drawings and documents / Non-disclosure and Information Obligations
	Drawings, technical documents or other technical information received by one party shall not without the consent of the other party, be used for any other purpose than that for which they were provided. They may not, without the consent of the submitting party, otherwise be used or copied, reproduced, transmitted or communicated to third parties. All information and data contained in general product documentation, whether in electronic or any other form, are confidential and binding only to the extent that they are by reference expressly included in the contract. The seller shall, as per agreed date/s but not later than the date of delivery, provide free of charge any information and/or drawings which are necessary to permit the Purchaser to erect, commission, operate and maintain the product. Such information and drawings shall be supplied in the number of copies agreed upon or at least three copies of each. All intellectual properties, including designs, drawings and product information etc. exchanged during the formation and execution of the contract shall continue to be the property of the submitting party. The seller shall provide Purchaser with all information pertaining to the delivery in so far as it could be of importance to Purchaser. The seller shall not reveal confidential information to its own employees not involved with the tender/contract and its execution and delivery or to third parties, unless Purchaser has agreed to this in writing beforehand. The seller shall not be entitled to use the Purchaser's name in advertisements and other commercial publications including website without prior written permission from Purchaser. In the event of violation of the confidentiality as agreed, BHEL will take legal action as deemed fit. Non disclosure agreement to be entered as per Annexure- II wherever applicable.

(Attachment to Enquiry No. E5A1V04433 Due on Date 07.04.2022 for submission by 11.00 hrs to open from 14:00 hrs.)	
INSTRUCTIONS TO BIDDER (ITB)	
42	Inspection and Testing
42 A	<p>The goods and stores shall be manufactured by approved quality system and each part/component may be inspected and tested by the Purchaser prior to shipment and shall fully comply with relevant requirements of Purchaser.</p> <p>Purchaser has the right to inspect at any stage during manufacture/ delivery. In the event of rejection, Purchaser shall inform the seller accordingly and Purchaser shall be entitled to replacement or repair at his discretion or may proceed to terminate or cancel the agreement. All this, does not affect Purchaser's right to recover compensation.</p>
42 B	<p>Purchaser or his authorized representative shall be entitled at all reasonable times during execution to inspect, examine and test at the seller's premises the material and workmanship of all stores to be supplied under the contract, and if the part of the stores are being manufactured at other premises, the seller shall obtain for purchaser or his authorized representative permission to inspect, examine and test as if the said stores are being manufactured at the seller's premises. Such inspection, examination and testing, if made shall not release the seller from any obligation under the contract.</p> <p>For indigenous suppliers all costs related to first inspection request shall be borne by the purchaser and the cost of subsequent inspections due to non-readiness of material/rework/ rejections shall be borne by the seller. In case of imports all inspection charges including third party inspections if any shall be borne by the seller. The cost of inspection staff/third party specified by the Purchaser shall be borne by seller unless otherwise specifically agreed. Whether the contract provides for tests on the premises of the seller or any of his sub-contractor/s, seller shall be responsible to provide such assistance, labor, materials, electricity, fuels, stores, apparatus, instruments as may be required and as may be reasonably demanded to carry out such tests efficiently.</p> <p>Cost of any type test or such other special tests shall be borne by the seller unless otherwise specifically agreed in the contract. The Seller shall give the authorized representative of the purchaser reasonable notice in writing of the date on and the place at which any stores will be ready for inspection/ testing as provided in the Contract. Annexure - I may be strictly be complied with for the time lines. Any delay in submission of the documents by the vendor will not alter the delivery date.</p>
43	Quality and Condition of the Deliverables
	The seller shall be responsible for compliance with applicable technical, safety, quality, environmental requirements and other regulations in relation to his products, packaging and raw and ancillary materials.
44	Packaging and Dispatch
	<p>The seller shall package the deliverables safely and carefully and pack them suitably in all respects considering the peculiarity of the material for normal safe transport by sea/air/rail/road to its destination suitably protected against loss, damage, corrosion in transit and the effect or tropical salt laden atmosphere. The packages shall be provided with fixtures/hooks and sling marks as may be required for easy and safe handling by mechanical means. Special packaging conditions/ environmental conditions as defined in the enquiry shall be fully complied.</p> <p>Each package must be marked with consignee name, P.O. number Package No. gross weight & net weight, dimensions (LxBxH) and seller's name. The packing shall allow for easy removal and checking of goods on receipt and comply with carrier's conditions of packing or established trade practices. Packing list of goods inside each package with P.O. item No. & quantity must also be fixed securely outside the box to indicate the contents. If any consignment needs special handling instruction, the same shall be clearly marked with standard symbols/instructions. Hazardous material should be notified as such and their packing, transportation and other protection must confirm to relevant regulations.</p>
45	Delivery:
	Except as otherwise indicated in the Purchase order, delivery shall be FOR (Destination) for indigenous orders and CIP for imported orders. The delivery date (s) or delivery period (s) as stipulated in the agreement shall be firm and binding and shall apply to the entire delivery for each P.O. item. Partial shipments may however, be permitted by the purchaser on prior intimation from the Seller. Unless specifically agreed otherwise, transit insurance coverage will only be within India for imported consignments by BHEL. Accordingly, the seller shall send an intimation to the Purchase officer/Manager giving Purchase Order No., shipping particulars, Invoice value etc., immediately on dispatch of goods.
46	Penalty
	<p>The time or period of delivery as stipulated in the schedule of delivery shall be deemed to be the essence of the contract. Should circumstances arise whereby the deadline for an agreed delivery date(s) or period(s) is expected to be exceeded, the seller shall inform Purchaser hereof without delay. If delay in delivery is caused by any of the circumstances mentioned in clause 54 (Force Majeure) or which are caused exclusively by the acts of Purchaser, the Purchaser shall extend the time for delivery by a period which is reasonable having regard to all the circumstances in the case.</p> <p>If the Seller delays beyond any agreed delivery date(s) or period(s), Purchaser shall levy penalty for such delay @ 0.5% per week (7 days) or part thereof on delayed portion of the order value subject to a maximum of 10% of the value of the Purchase Order. However, penalty for delayed delivery will be calculated on 100% of the purchase order value if the material supplied cannot be put to intended use.</p> <p>The penalty will be charged on the value of the purchase order excluding statutory levies, freight and insurance wherever not included in the price. Penalty amount so determined along with applicable GST thereon shall be recovered.</p> <p>Imposition, recovery or settlement of this penalty shall not affect Purchaser's right to performance, compensation and termination of the agreement.</p> <p>For delay analysis, period referred in Annexure-I will be considered as standard time lines for various major activities.</p>
47	Transfer of Ownership and Risk
	The risk for the delivery remains with the seller until the goods are delivered at the agreed place. However ownership shall get transferred as per terms of purchase order in line with INCOTERMS.

(Attachment to Enquiry No. E5A1V04433 Due on Date 07.04.2022 for submission by 11.00 hrs to open from 14:00 hrs.)	
INSTRUCTIONS TO BIDDER (ITB)	
48	Price, invoicing and payment
	<p>The agreed prices are fixed prices in the currency as specified in the Purchase Order. They shall include packing, forwarding , loading and carriage to the place specified by the purchaser and are exclusive of all applicable taxes, duties etc., except for those specifically agreed by the Purchaser. Invoices shall be submitted bearing the Purchase Order number & date, item number/s and supporting documents as called for in the Purchaser order.</p> <p>The direct payments (including LC/documents through Bank on collection basis), shall be made by E-payment mode and not by cheque /bank drafts except in special circumstances. Vendors shall furnish the E-payment particulars in the prescribed formats duly authenticated by their respective Bankers, If not got registered earlier with the Buyer.</p> <p>Invoice has to be raised quoting HSN Code of Goods or Accounting Code of Services. Invoice should mention BHEL-HPEPHYDERABAD GSTIN: 36AAACB4146P1ZG or GSTIN of BHEL Nodal Agency as mentioned in PO.</p> <p>Indian Agency commission if payable and so specified in the Purchase order shall be paid in Indian Rupees, considering the SBI TT selling exchange rate prevailing on the date of tender opening (part 1 in case of two part bid), after successful completion of the contract.</p> <p>If so stipulated in the order, the seller shall furnish, on receipt of the Purchase Order or along with order acknowledgement, the billing break-up of prices (BBU) for approval by the purchaser in respect of the major items/components going into the equipment. This BBU is required by the Purchaser for admitting the claims of the seller if part shipments are contemplated and also to facilitate custom clearance after payment of duties in case of imports.</p> <p>In case of delay in receipt of supporting document details, consequential demurrage/wharf age /detention charges shall be to the account of the seller.</p> <p>Payment does not imply in any respect whatsoever a waiver of Purchaser's right to performance of the agreement. Purchaser is entitled to set off claimable debts against claimable liabilities with the seller by means of a setoff Note.</p>
49	Contract variations; Increase or decrease in the scope of supply
	<p>Purchaser may vary the contracted scope during execution due to exigencies of project requirement.</p> <p>If the seller is of the opinion that the variation has an effect on the agreed price or delivery period, Purchaser shall be informed of this immediately in writing along with technical details, and in the event of additional work, submit a quotation with regards to the price and period involved, as well as the effect this additional work will have on the other work to be performed by the seller. Provided, that if unit rates are available in the contract, the same shall be applied to such additional work. The seller shall not perform additional work before purchaser has issued written instructions/amendment to the purchase order to that effect. The work which the seller should have or could have anticipated in terms of delivering the service (s) and functionality (ies) as described in this agreement should be executed by the vendor without any price implication.</p>
50	Short shipments/ warranty/guarantee replacements
	<p>In case of any short shipment during initial supply which is subsequently dispatched by the seller or any guarantee / warranty replacements shall be dispatched on "DDP-Delivered duty paid BHEL stores" basis for imported items and "FOR-BHEL Stores/designated destination" basis for indigenous items. Taxes, if any paid by indigenous vendor for short supply, guarantee /warranty replacement, repair activity shall be to vendor's account only. Vendor has to raise a credit note for short supplied quantity as per GST provisions.</p>
51	Rejection/Replacement
	<p>The seller shall arrange replacement / repair under its obligation under the contract within one month from the date of intimation or mutually agreed period. The rejected goods shall be taken away by the seller and replaced on DDP/FOR-BHEL Stores/designated destination basis within such period. In the event of the seller's failure to comply. Purchaser may take appropriate action including disposal of rejections, at the cost and risk of the seller. Vendor has to raise a credit note for rejected quantity as per GST provisions.</p> <p>In case defects attributable to seller are detected during processing of the goods at purchaser's / his subcontractor works, the seller shall be responsible for replacement /repair of the goods as required by the purchaser at seller's cost.</p>
52	Export Administration Regulations
	<p>If a delivery includes such technology and / or supply that is subjected to the export regulations the seller shall obtain due permissions, approvals, license etc.</p>
53	Cancellation / Termination of contract and risk purchase
	<p>Purchaser shall have the right to completely or partially terminate the agreement by means of written notice to that effect without prejudicing their other rights in the event that :</p> <ul style="list-style-type: none"> - The seller is declared bankrupt, its business has been shut down or liquidated, a substantial part of its assets have been attached/destroyed, or the business has been transferred to a third party. - Any misrepresentation or hiding of material fact if detected at a later stage. - The delivery is rejected after inspection or re-inspection. - In the event of termination, the risk of the items already delivered but not of use to Purchaser, as determined by purchaser, remains with the seller. The items shall then be at the seller's disposal and they are to be collected by the seller. The seller shall refund any payments made by purchaser in terms of the terminated agreement immediately, not later than 30 days, - In the event of Cancellation/ termination of contract, BHEL reserves the right to procure the items which are not delivered as per PO and charge the excess cost from the defaulting seller. In case the excess cost is not repaid by or recovered from the defaulting seller within 30 days, apart from legal recourse for effecting such recoveries, Penal action in line with BHEL's Suspension of Business dealings will be taken.

(Attachment to Enquiry No. E5A1V04433 Due on Date 07.04.2022 for submission by 11.00 hrs to open from 14:00 hrs.)	
INSTRUCTIONS TO BIDDER (ITB)	
54	Force Majeure
	<p>The supplier shall not be considered in default if delay occurs due to causes beyond their control such as Acts of God, Natural calamities, Fire, Frost, Flood, Civil War, civil commotion, riot, Government Restrictions.</p> <p>Only those causes that have duration of more than seven days shall be considered cause of force majeure. Notification to this effect duly certified by local chamber of commerce/statutory authorities with supporting documents shall be given by the supplier to BHEL by registered letter/courier service immediately without loss of time.</p> <p>In the event of delay due to such causes the delivery schedule shall be extended for a length of time equal to the period of Force Majeure or at the option of BHEL the order may be cancelled. Such cancellation would be without any liability whatsoever on the part of BHEL.</p> <p>In the event of such cancellation the supplier shall refund any amount advanced or paid to the supplier by BHEL and deliver back any material issued to him by BHEL and release facilities, if any provided by BHEL.</p>
55	Non-waiver of Defaults
	If any individual provision of the contract is invalid, the other provisions shall not be affected.
56	Settlement of Disputes
	<p>(i) Except as otherwise specifically provided in the contract, all disputes concerning questions of the facts arising under the contract, shall be decided by the Purchaser, subject to written appeal by the seller to the purchaser, whose decision shall be final.</p> <p>(ii) Any disputes of differences shall to the extent possible be settled amicably between the parties thereto, failing which the disputed issues shall be settled through arbitration.</p> <p>(iii) The seller shall continue to perform the contract, pending settlement of disputes(s).</p>
57	Conciliation clause
	<p>CONCILIATION CLAUSE FOR CONDUCTING CONCILIATION PROCEEDINGS UNDER THE BHEL CONCILIATION SCHEME, 2018: The Parties agree that if at any time (whether before, during or after the arbitral or judicial proceedings), any Disputes (which term shall mean and include any dispute, difference, question or disagreement arising in connection with construction, meaning, operation, effect, interpretation or breach of the agreement, contract or the Memorandum of Understanding, penalty deduction, time extension), which the Parties are unable to settle mutually, arise inter-se the Parties, the same may, be referred by either party to Conciliation to be conducted through Independent Experts Committee to be appointed by competent authority of BHEL from the BHEL Panel of Conciliators.</p> <p>The proceedings of Conciliation shall broadly be governed by Part-III of the Arbitration and Conciliation Act 1996 or any statutory modification thereof and as provided in Procedure in http://www.bhel.com/index.php/story_details?story=2454. The Procedure together with its Formats will be treated as if the same is part and parcel hereof and shall be as effectual as if set out herein in this ITB.</p>
	ARBITRATION (WITH SOLE ARBITRATOR)
	<p>Except as provided elsewhere in this Contract, in case amicable settlement is not reached between the Parties, in respect of any dispute or difference; arising out of the formation, breach, termination, penalty deduction, validity or execution of the Contract; time extension, or, the respective rights and liabilities of the Parties; or, in relation to interpretation of any provision of the Contract; or, in any manner touching upon the Contract, then, either Party may, by a notice in writing to the other Party refer such dispute or difference to the sole arbitration . Sole arbitrator to be appointed by Head of the Unit - BHEL , HPEP .</p> <p>The Arbitrator shall pass a reasoned award and the award of the Arbitrator shall be final and binding upon the Parties.</p> <p>Subject as aforesaid, the provisions of Arbitration and Conciliation Act 1996 (India) or statutory modifications or re-enactments thereof and the rules made thereunder and for the time being in force shall apply to the arbitration proceedings under this clause.</p> <p>The seat of arbitration shall be Sangareddy / Hyderabad, Telangana. The language of arbitration shall be English and the documents shall be submitted in English.</p> <p>The cost of arbitration shall initially be borne equally by the Parties subject to the final apportionment of the cost of the arbitration in the award of the Arbitrator.</p> <p>Subject to the arbitration in terms of clause 57, the courts at Sangareddy, Telangana State shall have exclusive jurisdiction over any matter arising out of or in connection with this contract.</p> <p>Notwithstanding the existence or any dispute or differences and/or reference for the arbitration, the Contractor shall proceed with and continue without hindrance the performance of its obligations under this Contract with due diligence and expedition in a professional manner except where the Contract has been terminated by either Party in terms of this Contract.</p>
	ARBITRATION FOR CONTRACT WITH PUBLIC SECTOR ENTERPRISE (PSE) OR A GOVERNMENT DEPARTMENT
	<p>In the event of any dispute or difference relating to the interpretation and application of the provisions of commercial contract(s) between Central Public Sector Enterprises (CPSEs/ Port Trusts inter se and also between CPSEs and Government Departments/Organizations (excluding disputes concerning Railways, Income Tax, Customs & Excise Departments), such dispute or difference shall be taken up by either party for resolution through AMRCD as mentioned in DPE 0M No 4(1)/2013-DPE(GM/FTS 1835 dated 22-05-2018</p>
58	Applicable Laws and jurisdiction of Courts
	This agreement shall be construed and interpreted in accordance with the laws of India and shall have exclusive jurisdiction of Sangareddy/Hyderabad courts, Telangana, India.

(Attachment to Enquiry No. E5A1V04433 Due on Date 07.04.2022 for submission by 11.00 hrs to open from 14:00 hrs.)

INSTRUCTIONS TO BIDDER (ITB)

59	BHEL-Fraud prevention policy shall be adhered to.
	The Bidder along with its associate/ Collaborators/ Sub-contractors/ sub-vendors/ consultants/ service providers shall strictly adhere to BHEL Fraud Prevention policy displayed on BHEL Website http://www.bhel.com and shall immediately bring to the notice of BHEL management about any fraud or suspected fraud as soon as it comes to their notice.
	Fraud prevention policy and list of nodal officers is hosted on BHEL Hyderabad website web.bhelhyd.co.in
60	Suspected Cartel Formation
	The Bidder declares that they will not enter into any illegal or undisclosed agreement or understanding , whether formal or informal with other Bidder(s) . This applies in particular to prices , specifications ,certifications ,subsidiary contracts,submission or nonsubmission of bids or any other actions to restrict competitiveness or to introduce cartelization in the bidding process. In case, the Bidder is found having indulged in above activities , suitable action shall be taken by BHEL as per extant policies / guidelines .

FIRST ANGLE PROJECTION

(ALL DIMENSIONS ARE IN mm)

INVENTORY NO. SIGN. AND DATE REF. DRG. NO. THE INFORMATION ON THIS DOCUMENT IS THE PROPERTY OF BHARAT HEAVY ELECTRICALS LIMITED. IT MUST NOT BE USED DIRECTLY OR INDIRECTLY IN ANY WAY DETRIMENTAL TO THE INTEREST OF THE COMPANY

REV.	DATE	ALTERED	CHECKED	APPD	REV.	DATE	ALTERED	CHECKED	APPD	ADDITIONAL INFORMATION
										STATUS OF DRAWING
										DISTURIBUTION OF PRINTS

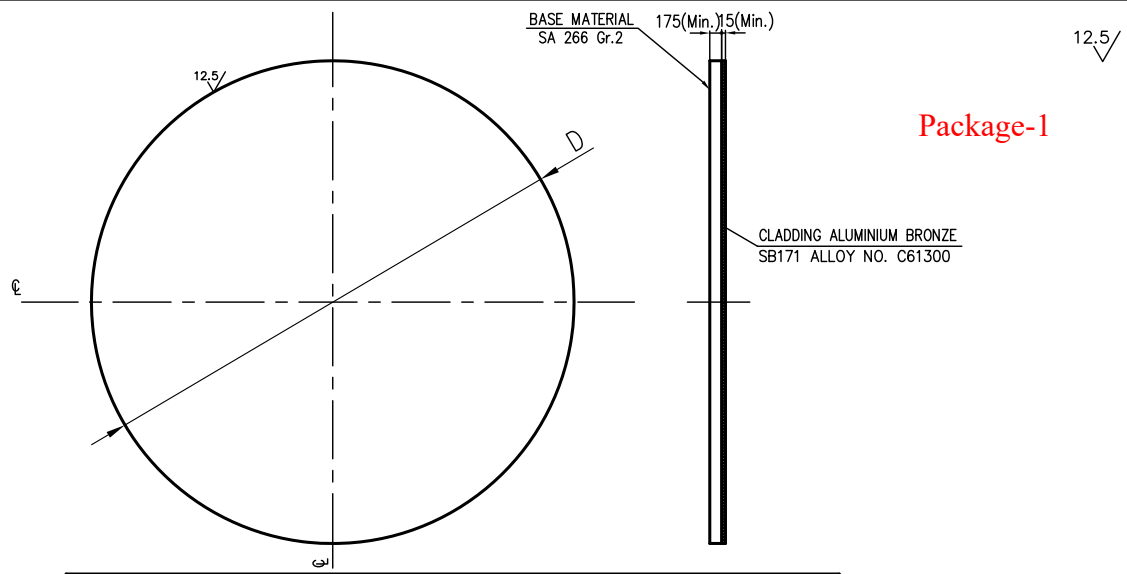

Package-1

VAR.No.	DESCRIPTION	D	QTY	MATERIAL CODE	WT(Kg)
01	CLADDED TUBE SHEET(FIXED)	879	1	HE9718634150	909
02	CLADDED TUBE SHEET (FLOATING)	716	1	HE9718634169	603

VAR.No.	DESCRIPTION	L	B	THK	QTY	MATERIAL CODE	WT(Kg)
03	CLADDED MOCK UP PIECE	150	150	175+15	3	HE9715464149	34

NOTE :-

- MATERIAL:-
 - BASE MATERIAL SHALL BE AS PER SA 266 Gr.2 OF ASME SEC.II PART-'A' LATEST EDITION AS PER INDENT.
 - CLADDING MATERIAL SHALL BE AS PER SB 171 C61300 OF ASME SEC.II PART 'B' LATEST EDITION AS PER INDENT.
- CLADDING SHALL BE INTEGRALLY AND CONTINUOUSLY BONDED TO THE BASE MATL. AND CLADDING REQUIRED ON ONE SIDE ONLY.
- BOND BETWEEN CLADDING AND THE BASE METAL SHALL BE CHECKED FOR A MINIMUM STRENGTH OF 8.5 kgf/sq.mm IN SHEAR BY CONDUCTING SHEAR TEST.
- CLAD PLATE SHALL BE ULTRASONICALLY EXAMINED FROM THE CLAD SURFACE AS PER SA 578. SCANNING SHALL BE 100 % OF THE PLATE SURFACE. ACCEPTANCE STD. SHALL BE LEVEL-A OF B432.
- BASE FORGING MATERIAL TO BE SUPPLIED IN NORMALISED & TEMPERED CONDITION AND CARBON CONTENT SHALL NOT BE GREATER THAN 0.25 %.
- BASE FORGING SHALL BE ULTRASONICALLY TESTED AS PER SA 388 OF ASME SEC-II PART-A LATEST CODE AND ADDENDA, ACCEPTANCE STANDARD SHALL BE AS PER CLAUSE 3.3.4 OF ASME SECTION VIII DIV-2 CODE & ADDENDA AS PER INDENT
- BASE MATERIAL TO BE CHАРY V-NOTCH IMPACT TESTED AND MINIMUM IMPACT ENERGY REQUIRED FOR AVERAGE OF 3 SPECIMENS SHALL BE 20J. MINIMUM IMPACT ENERGY PERMITTED IS 16J FOR ONE SPECIMEN ONLY OF A SET.IMPACT TEST TEMPERATURE SHALL BE -46°C.
- FLATNESS ON THE CLADDED SURFACE SHOULD BE LIMITED TO 1 mm ON ENTIRE SURFACE OF TUBE PLATE. THE SAME SHOULD BE INSPECTED AND CERTIFIED BY BHEL TPIA
- INSPECTION AND CERTIFICATION BY BHEL TPIA
- THE TOLERANCE ON MATERIAL SHALL BE LIMITED TO PLUS 2.0 mm,MINUS 0.0 mm.

ITEM NO.	DESCRIPTION	DRAWING NO.	MATL. CODE	UNIT Wt.
			MATL. SPEN.	QTY.

	BHARAT HEAVY ELECTRICALS LTD. HYDERABAD		DRN.	NAME	SIGN.	DATE	NO.OF VAR.
			CHD.	A K SAHOO	A.K.S	16.12.21	
			APPD.	K KISHORE KUMAR	K.K.K	16.12.21	
				A CHANDRASEKHAR	A.C.S	16.12.21	NA

DEPT. HED	GRADE OF TOL.DIM.		SCALE	WEIGHT (KG)	REF. TO ASSY DRG.	ITEM NO.	NO.OF ITEMS
CODE 405	φ/M/F		NTS	-	NA	NA	NA

TITLE SA266 Gr.2+Aluminium Bronze Clad Feb Wed 16 13:16 2022 (FIXED & FLOATING TUBESHEET)			CARD CODE	DRAWING NO. 4-166-80-06035	REV. 100
				This Drawing is printed from Engineering Digital Archive System (EDAS). Therefore signatures are not essentially required.	
				SHEET NO.	NO OF SHEETS

PRE-QUALIFICATION CRITERIA(PQC)				
CLADDED TUBESHEET (Document no: D41668006077, Rev 00)				
S.No.	BHEL Requirement	Vendor's Confirmation	Deviation if Any	Remarks
1	All the suppliers need to submit this document i.e. titled pre-qualification criteria and furnish required information along with offer.			
2	<p>a) Name, address, e-mail id, contact no.etc. of manufacturing mill for Clad Plate.</p> <p>b) Name, address, e-mail id, contact no.etc. of authourised agency / trading house quoting on behalf of manufacturing mill. In case offer is received from authourised agency / trading house, the following requirements shall be full filled. i) Valid letter of authorisation and copy of agreement to be enclosed with offer. ii) The offer shall be either from the authorised agency or from the manufacturer directly. In case of BHEL receiving offer from both, then offer from manufaturer will only be considered. Offer from an unauthorised agency / entity on behalf of any vendor shall be summarily rejected. iii) Name, address, e-mail id, contact no.etc. of entity on whom order to be released in case of L1 shall be clearly indicated.</p>			<p>Bidder to tick the below as applicable: -OEM. -Authorized agency/trading house. If so 2(b) requirements to be met.</p>
3	<p>Supplier to confirm/provide the following criteria/documents for evaluation of offer.</p> <p>(a) The supplier shall have the proven experience in manufacturing and supply of cladded plate for any heat exchangers / pressure vessels etc as mentioned below.</p> <p>i) Base Material : Carbon Steel(ASME Grade)</p> <p>ii) Base material min thickness 20 mm and above and Diameter Min 100 mm</p> <p>iii) Clad material : Ferrous or Non-Ferrous(ASME Grade)</p> <p>iv) Clad material min thickness 3mm and above.</p> <p>v) Application: Any Heat exchanger / pressure vessel</p> <p>v) Service: Thermal power plant/Nuclear power plant/Refineries/Fertilizers etc</p> <p>vii) Satisfactory Working : Supplier should have sucessfully supplied clad plates against 2 such commercial orders as on the date of enquiry.</p> <p>viii) All the facilities required for manufacturing of cladded tubesheet i.e explosion bonding shall be readily available with the vendor and also shall meet the requirements of cladded plate specification .</p> <p>All the above criteria 3(a) (i) to 3(a) (viii) must be combinedly met by the vendor against atleast two supply reference of cladded tubesheets.</p> <p>(b) The supplier meeting all the above criteria as 3 (a) (i) to 3 (a) (viii) shall furnish details of such supplies only as indicated above (sl no 3 (a)) including equipment / vessel Manufacturer's Name, date of supply (in DDMMYY format), Size, Material, Quantity and full contact details of equipment Manufacturer (including Mobile no and e-Mail ID). OR Heat Exchanger / vessel Manufacturer's certificate (in English) containing the supply details as above both 3(a) & 3 (b), Contact details [E-Mail ID, Land line/Mobile No. and complete address of Heat exchanger Manufacturer may be furnished. Vendors who have already supplied Cladded tubesheets (for Heat exchangers) to BHEL-Hyd are exempted from furnishing the above documents if their supply records are available with BHEL. However such supplies have to meet all other requirements of this PQC. Note : Suppliers shall furnish minimum 2 and maximum upto 6 number of latest customer reference details as indicated above in the attached Annexure-I. Details furnished in any other format shall not be considered. All the documents shall be furnished only in English. Documents furnished in other languages will not be considered for further evaluation.</p>			
4	(c) BHEL reserves the right to cross verify with the above such customers and satisfy itself with reference to the claims of the supplier. If the information furnished by the supplier is not found satisfactory, the offer will be technically rejected.			
5	Offers without the requirement as above 3(a) & 3(b) will not be technically evaluated by BHEL. Further, no correspondence in this matter will be entertained.			
6	The vendors shall furnish the detailed process of manufacturing and testing procedures along with the offer if requested.			
7	List of BHEL qualified bidders may be forwarded to BHEL's End Customer for their review and approval. The list finalized by BHEL's End Customer shall be final and binding.			
8	BHEL team may carry out vendor evaluation/assesment(incase of a new vendor)by a visit to vendor works for qualifying /rejecting the technical bid based on the findings of the visit.			
9	Vendors to submit their bid in 2- part system, i.e. Part-I shall consists of Pre-Qualification Criteria along with the required documnets and Techno-commercial bids and Part-II shall consists of Price Bid. Offers failing to meet prequalification part will not be considered for further evaluation.			
Prepared By	Checked By			Approved By
AKS	KKK			ACS

Annexure-1								
Heat Exchanger Cladded tubesheet Reference details								
Ref project S.no	Base Material	Clad Material	Base material OD (Min. 100mm & above) and thickness(Min. 20mm & above)	Clad material OD (Min. 100mm & above) and thickness(Min. 3mm & above)	Supply date DDMMYYYY	Heat exchanger Manufacturer details		
						Supplied to (Manufacturer's name)	Contact person	E-Mail id &Phone no
1								
2								
3								
4								
5								
6								

- Note:
- a) Reference list shall be submitted in the above format only.
Vendors are requested to fill the above and submit along with PreQualification Criteria(PQC).Details mentioned above only are considered for PQC evaluation.
 - b) wherever details are not available,vendor to mention as "NA"
 - c) Reference project Cladded tubesheet OD shall be 100 mm and above. Other Cladded tubesheets shall be considered as INVALID Reference.
 - d) Reference project Clad tubesheet total thickness (clad+base metal)shall be 23 mm and above.
Minimum 01 and Maximum of 06 such reference shall be mentioned in the above table. (For ease of evaluation)

	BHARAT HEAVY ELECTRICALS LIMITED R.C.PURAM, HYDERABAD	STANDARD QUALITY PLAN FOR VENDOR ITEMS						QP. NO: HY/QA/VSQP/TCMO/009/ W-1032608900 REV. NO. : 00 DATE: 14.02.2022			
		ITEM: CLADDED TUBE PLATE (SA 266 GR.2 + SB 171 C61300) LATEST ASME EDITION SHALL BE FOLLOWED BHEL DRAWING: 41668006035-S00-R00 PROJECT: M-HN-1011 CB& I/TOYO						PAGE 1 OF 3 Package-1			

SL NO	COMPONENT & OPERATIONS	CHARACTERISTICS	CLASS	TYPE OF CHECK	QUANTUM OF CHECK	REF DOCUMENT	ACCEPTANCE NORMS	FORMAT OF RECORD	*D	AGENCY			REMARKS
										P	W	V	
1.0	RAW MATERIAL												
1.1	BASE MATERIAL	CHEMICAL COMPOSITION	MAJOR	CHEMICAL	AS PER SPEC.	SA 266 Gr.2	SA 266 Gr.2	SUPPLIER'S TC	✓	2		1,3	C<= 0.25%
1.2		REVIEW OF HEAT TREATMENT CHART	MAJOR	HT	100%	SA 266 Gr.2	SA 266 Gr.2	HT CHART	✓	2		1,3	
1.3		MECHANICAL PROPERTIES	MAJOR	MECH.	AS PER SPEC.	SA 266 Gr.2	SA 266 Gr.2	SUPPLIER'S TC	✓	2		1,3	
		IMPACT TESTING @ -46 Deg C	MAJOR	MECH.	AS PER SPEC.	SA 266 Gr.2	SA 266 Gr.2, DRAWING	SUPPLIER'S TC	✓	2		1,3	Avg of 3 Sample
1.4		UT EXAM	MAJOR	NDE	100%	SA 388	CL 3.3.4 OF ASME SEC VIII DEV 2	SUPPLIER'S TC	✓	2		1,3	
1.5	CLADDED MATERIAL	CHEMICAL COMPOSITION	MAJOR	CHEMICAL	AS PER SPEC.	SB171 C61300	SB171 C61300	SUPPLIER'S TC	✓	2		1,3	
1.6		MECHANICAL PROPERTIES	MAJOR	MECH.	AS PER SPEC.	SB171 C61300	SB171 C61300	SUPPLIER'S TC	✓	2		1,3	
1.7		UT EXAM	MAJOR	NDE	100%	SA 578 ,DRAWING	SA 578 L-B	SUPPLIER'S TC/IR	✓	2		1,3	
1.8	PROCESS INSPECTION	UT EXAM ON CLADDED TUBE PLATE (FROM THE CLAD SURFACE)	MAJOR	NDE	100%	ASTM B 432 & DRAWING	ASTM B 432 (LEVEL -A) , DRAWING	NDE REPORT	✓	2	1,3		Note-1 & 2
1.9		CHECK FOR BOND BETWEEN CLADDING AND BASE METAL	MAJOR	SHEAR TEST	ONE SAMPLE	DRAWING	DRAWING	IR	✓	2	1,3		
1.10		VISUAL EXAM AND DIMENSIONS	MAJOR	VISUAL & MEASURT.	100%	DRAWING	DRAWING	IR	✓	2	1,3		
1.11		FLATNESS	MAJOR	MEASRT.	100%	DRAWING	DRAWING	IR	✓	2	1,3		
1.12		VERIFICATION OF TCS, IDENTIFICATION OF MATERIAL FOR COMPLETION AS PER DRAWING & QP	MAJOR	VISUAL	100%	DRAWING & QP	DRAWING & QP	SUPPLIER'S TC,IR		2		1,3	
1.13		PACKING AND MARKING	MAJOR	VISUAL	100%	P.O.	P.O.	IR	✓	2		1,3	

LEGEND:
P: - PERFORM, W: - WITNESS, V: - VERIFICATION,
INDICATING 1: - BHEL / BHEL NOMMNATED INSPECTION AGENCY, 2: - VENDOR / SUB VENDOR 3. END CUSTOMER /END CUSTOMER TPIA AS APPROPRIATE AGAINST EACH COMPONENT / CHARACTERISTICS UNDER THE COLUMNS P, W & V.
* D: RECORDS IDENTIFIED WITH TICK (✓) SHALL BE ESSENTIALLY INCLUDED IN QA DOCUMENTATION.

PREPARED BY:



ALOK BEHERA
DY.MGR/ QA

REVIEWED BY:



B. ASHOK KUMAR
AGM/QA

APPROVED BY:



B. ASHOK KUMAR
AGM/QA



		BHARAT HEAVY ELECTRICALS LIMITED R.C.PURAM, HYDERABAD		STANDARD QUALITY PLAN FOR VENDOR ITEMS				QP. NO: HY/QA/VSQP/TCMO/009/ W-1032608900 REV. NO. : 00 DATE: 14.02.2022 PAGE 2 OF 3					
				ITEM: CLADDED TUBE PLATE (SA 266 GR.2 + SB 171 C61300) LATEST ASME EDITION SHALL BE FOLLOWED BHEL DRAWING: 41668006035-S00-R00 PROJECT: M-HN-1011 CB& I/TOYO				Package-1					
SL NO	COMPONENT & OPERATIONS	CHARACTERISTICS	CLASS	TYPE OF CHECK	QUANTUM OF CHECK	REF DOCUMENT	ACCEPTANCE NORMS	FORMAT OF RECORD	*D	AGENCY			REMARKS
										P	W	V	
1.14	DESPATCH	DESPATCH (PHOTOGRAPHS SHALL BE INCLUDED)	MAJOR	VISUAL	100 %	P.O	P.O	PHOTOGRAHS	✓	2			

NOTES:

1. CLADDING SHALL BE INTEGRALLY AND CONTINOUS BONDED TO BASE MATERIAL AND CLADDING REQUIRED ON ONE SIDE ONLY.
2. NO REPAIR BY WELDING IS PERMITTED.

NOTES FOR INSPECTOR - TPIA



1. TPIA TO CHECK THE LATEST VERSION OF STANDARDS/DRAWINGS /TOLERANCES ETC TO BE MENTIONED IN QUALITY PLAN/DRAWING. THIS QP SHOULD BE READ ALONG WITH BHEL SPEC, BHEL DRAWINGS / APPROVED DRAWINGS, DATA SHEET, BOM AND PO.
2. ONLY LEVEL II & ABOVE QUALIFIED PERSON IN RESPECTIVE NDE TO VERIFY OR WITNESS THE NDT TEST REPORT/RESULTS
3. INSPECTOR TO ENSURE THAT DOCUMENTS (QUALITY PLAN, DRAWINGS, DATA SHEET, PURCHASE SPECIFICATIONS, ETC) ARE AVAILABLE AS PER PURCHASE ORDER BEFORE STARTING THE INSPECTION.
4. TPIA TO REVIEW ONLY THE ORIGINAL TEST CERTIFICATES ISSUED BY THIRD PARTY LABORATORIES OR SUPPLIERS.
5. INSPECTION REPORTS SHALL BE SUBMITTED WITH A REMARK THAT ' COMPARED WITH ORIGINAL TEST CERTIFICATE. REVIEWED, VERIFIED AND FOUND IN ORDER '. TPIA TO ENSURE THE SAME.
6. INSPECTOR TO ENSURE USE OF VALID AND CALIBRATED MEASURING INSTRUMENTS AND EQUIPMENT.
7. TPIA SHALL ENSURE THAT MATERIAL TEST CERTIFICATAE & TRACEABILITY RECORDS ARE AVAILABLE FOR USE OF CORRECT MATERIAL
8. QUALIFICATION OF EQUIPMENT, PROCESS & PERSONNEL FOR SPECIAL PROCESSES LIKE WELDING, BRAZING, PAINTING & METAL COATING ETC.
9. TPIA TO ENDORSE ON ALL CERTIFICATES WITH COMMENTS (WITNESSED OR VERIFIED) AS PER QUALITY PLAN
10. TPIA SHALL ENSURE THAT LOG SHEETS CONTAIN ACTUAL MEASURED VALUES INSTEAD OF SAYING OK/NOT OK.
11. COMPLETE INSPECTION AND TEST DOCUMENTATION WHICHEVER IS IDENTIFIED WITH (v) UNDER COLUMN D OF APPROVED QULAIITY PLAN SHALL BE ENCLOSED WITH THE INSPECTION REPORT. ALL TEST CERTIFICATES/ REPORTS REVIEWED AND CERTIFIED BY BHEL/TPI SHALL BE SUBMITTED TO BHEL AS DOCUMENTATION PACKAGE
12. ORIGINAL COPIES OF ALL INSPECTION AND TEST DOCUMENTS AUTHENTICATED BY TPIA SHALL BE SUBMITTED.

LEGEND: P: - PERFORM, W: - WITNESS, V: - VERIFICATION, INDICATING 1: - BHEL / BHEL NOMMNATED INSPECTION AGENCY, 2: - VENDOR / SUB VENDOR 3. END CUSTOMER /END CUSTOMER TPIA AS APPROPRIATE AGAINST EACH COMPONENT / CHARACTERISTICS UNDER THE COLUMNS P, W & V. * D: RECORDS IDENTIFIED WITH TICK (✓) SHALL BE ESSENTIALLY INCLUDED IN QA DOCUMENTATION.	PREPARED BY:  ALOK BEHERA DY.MGR/ QA	REVIEWED BY:  B. ASHOK KUMAR AGM/QA	APPROVED BY:  B. ASHOK KUMAR AGM/QA
	Format no. : HYQA/QP/VSQP Rev.02		

		BHARAT HEAVY ELECTRICALS LIMITED R.C.PURAM, HYDERABAD		STANDARD QUALITY PLAN FOR VENDOR ITEMS				QP. NO: HY/QA/VSQP/TCMO/009/ W-1032608900 REV. NO. : 00 DATE: 14.02.2022					
				ITEM: CLADDED TUBE PLATE (SA 266 GR.2 + SB 171 C61300) LATEST ASME EDITION SHALL BE FOLLOWED BHEL DRAWING: 41668006035-S00-R00 PROJECT: M-HN-1011 CB& I/TOYO				PAGE 3 OF 3 Package-1					
SL NO	COMPONENT & OPERATIONS	CHARACTERISTICS	CLASS	TYPE OF CHECK	QUANTUM OF CHECK	REF DOCUMENT	ACCEPTANCE NORMS	FORMAT OF RECORD	*D	AGENCY			REMARKS
										P	W	V	

GENERAL NOTES

- BHEL RESERVES THE RIGHT FOR CONDUCTING REPEAT TEST, IF REQUIRED.
- BHEL APPROVED INSPECTION ENGINEERS TO BE DEPLOYED FOR INSPECTION.
- DRAWING / DATA SHEET SHALL PREVAIL OVER QUALITY PLAN IN CASE OF ANY CONTRADICTION BETWEEN QUALITY PLAN AND DRAWING / DATA SHEET.
- ALL TEST REPORTS SHALL BE PROVIDED AS PER PRESCRIBED FORMATS IN BHEL SPEC.
- ANY OTHER TESTS/ CHECKS INDICATED IN SPECIFICATION, P.O., OR DRAWING & ANY ADDITIONAL CHECKS ENVISAGED BY BHEL/TPI TO ENSURE WORKMANSHIP, FINISH, AESTHETICS, ETC. SHALL ALSO BE CONDUCTED AND WITNESSED/VERIFIED BY BHEL /TPI / CUSTOMER AS REQUIRED

LEGEND: P: - PERFORM, W: - WITNESS, V: - VERIFICATION, INDICATING 1: - BHEL / BHEL NOMMNATED INSPECTION AGENCY, 2: - VENDOR / SUB VENDOR 3. END CUSTOMER /END CUSTOMER TPIA AS APPROPRIATE AGAINST EACH COMPONENT / CHARACTERISTICS UNDER THE COLUMNS P, W & V. * D: RECORDS IDENTIFIED WITH TICK (✓) SHALL BE ESSENTIALLY INCLUDED IN QA DOCUMENTATION.	PREPARED BY:  ALOK BEHERA DY.MGR/ QA	REVIEWED BY:  B. ASHOK KUMAR AGM/QA	APPROVED BY:  B. ASHOK KUMAR AGM/QA
--	---	--	--

FIRST ANGLE PROJECTION

(ALL DIMENSIONS ARE IN mm)

INVENTORY NO. SIGN. AND DATE REF. DRG. NO. THE INFORMATION ON THIS DOCUMENT IS THE PROPERTY OF BHARAT HEAVY ELECTRICALS LIMITED. IT MUST NOT BE USED DIRECTLY OR INDIRECTLY IN ANY WAY DETRIMENTAL TO THE INTEREST OF THE COMPANY

REV.	DATE	ALTERED	CHECKED	APPD	REV.	DATE	ALTERED	CHECKED	APPD	ADDITIONAL INFORMATION
										STATUS OF DRAWING
Package-2										
					DISTURIBUTION OF PRINTS					

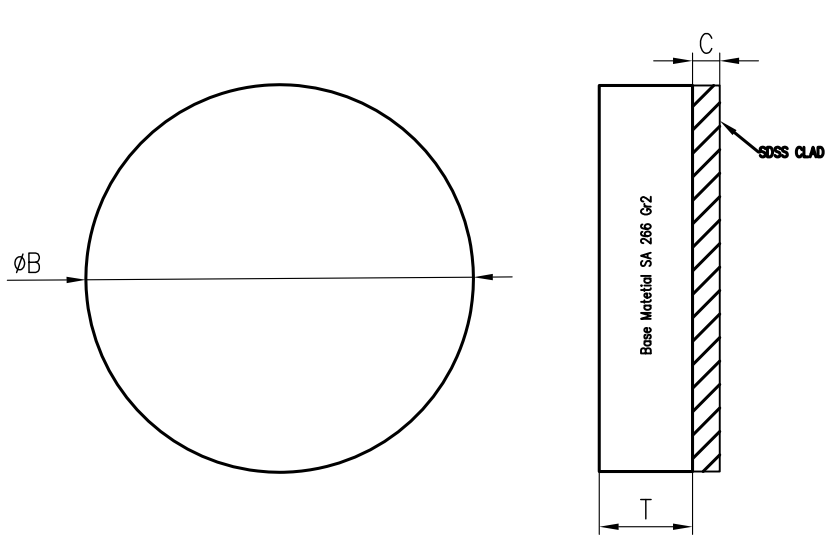

ITEM	DESCRIPTION	BASE MATERIAL (T)	ϕB	CLAD MATERIAL(C)	WEIGHT(kg)
01	TUBE SHEET FRONT SIDE	45	337	18	43.5
02	TUBE SHEET REAR	45	237.5	18	21.7

NOTE: -

1. BASE MATERIAL SHALL CONFORM TO SA 266 GRADE 2 OF ASME SEC-II PART-A CODE & EDITION AS PER ENQUIRY INCLUDING NACE MR0103 REQUIREMENT
2. CLAD MATERIAL SHALL SUPER DUPLEX STAINLESS STEEL (SA 240 S32750) AND SHALL CONFORM TO SA-264 OF ASME SEC-II PART-A CODE & EDITION AS PER ENQUIRY
3. TOLERANCES ON ALL DIMENSIONS +1 mm.
-0 mm
4. CLADDING SHALL BE INTEGRALLY AND CONTINUOUSLY BONDED TO THE BASE MATL. AND CLADDING REQUIRED ON ONE SIDE ONLY.
5. BASE FORGING SHALL BE ULTRASONICALLY TESTED AS PER SA 388 OF ASME SEC-II PART-A LATEST
6. CLAD PLATE SHALL BE ULTRASONICALLY EXAMINED FROM THE CLAD SURFACE AS PER SA 578. SCANNING SHALL BE 100 % OF THE PLATE SURFACE. ACCEPTANCE STD. SHALL BE LEVEL-C.
7. BOND BETWEEN CLADDING AND THE BASE METAL SHALL BE CHECKED FOR A MINIMUM STRENGTH OF 14 kgf/sq.mm IN SHEAR BY CONDUCTING SHEAR TEST
8. BASE FORGING MATERIAL TO BE SUPPLIED IN NORMALISED & TEMPERED CONDITION AND CARBON CONTENT SHALL NOT BE GREATER THAN 0.25 %.
9. FLATNESS ON THE CLADDED SURFACE SHOULD BE LIMITED TO 1 mm ON ENTIRE SURFACE OF TUBE PLATE THE SAME SHOULD BE INSPECTED AND CERTIFIED BY BHEL TPIA.
9. BASE MATERIAL SHALL CONFORM TO NACE MR0103 REQUIREMENTS.
10. INSPECTION BY M/S BHEL TPIA

ITEM NO.	DESCRIPTION	DRAWING NO.	MATL. CODE	UNIT Wt.
			MATL. SPEN.	QTY.

	BHARAT HEAVY ELECTRICALS LTD. HYDERABAD		DRN.	NAME	SIGN.	DATE	NO. OF VAR.
			CHD.	V C C SAGAR	VCCS	28.01.22	
			APPD.	K KISHORE KUMAR	KKK	28.01.22	
DEPT. HED	GRADE OF TOL. DIM.		SCALE	WEIGHT (KG)	REF. TO ASSY DRG.	ITEM NO.	NO. OF ITEMS
CODE 405	ϕ /M/F		NTS	-	NA	NA	NA

TITLE	CARD CODE	DRAWING NO.	REV.
SA266 Gr.2 + SDSS Clad		4-166-80-06079	100
(FIXED & FLOATING TUBESHEET)		SHEET NO.	NO OF SHEETS

Feb Sat 26 08:44 2022

This Drawing is printed from Engineering Digital Archive System (EDAS). Therefore signatures are not essentially required.

PRE-QUALIFICATION CRITERIA(PQC)

CLADDED TUBESHEET (Document no: D41668006064, Rev 00)

S.No.	BHEL Requirement	Vendor's Confirmation	Deviation if Any	Remarks
1	All the suppliers need to submit this document i.e. titled pre-qualification criteria and furnish required information along with offer.			
2	<p>a) Name, address, e-mail id, contact no.etc. of manufacturing mill for Clad Plate.</p> <p>b) Name, address, e-mail id, contact no.etc. of authourised agency / trading house quoting on behalf of manufacturing mill. In case offer is received from authourised agency / trading house, the following requirements shall be full filled. i) Valid letter of authorisation and copy of agreement to be enclosed with offer. ii) The offer shall be either from the authorised agency or from the manufacturer directly. In case of BHEL receiving offer from both, then offer from manufaturer will only be considered. Offer from an unauthorised agency / entity on behalf of any vendor shall be summarily rejected. iii) Name, address, e-mail id, contact no.etc. of entity on whom order to be released in case of L1 shall be clearly indicated.</p>			<p>Bidder to tick the below as applicable: -OEM. -Authorized agency/trading house. If so 2(b) requirements to be met.</p>
3	Supplier to confirm/provide the following criteria/documents for evaluation of offer.			
	(a) The supplier shall have the proven experience in manufacturing and supply of stainless steel clad carbon steel plate for any heat exchangers in power plant/refinery application as mentioned below.			
	i) Base Material : Carbon Steel SA 266 GR.1 to Gr.4 / SA 105 / SA 350 LF2			
	ii) Base material min thickness 20 mm and above and Diameter Min 100 mm			
	iii) Cladd material : SA 240 S32750 /TP316/316L/304/304L/321/321L			
	iv) Cladd material min thickness 3mm and above.			
	v) Application: Any Heat exchanger in power plants/refineries/fertilizers.			
	v) Service: Thermal power plant/Nuclear power plant/Refineries/Fertilizers.			
	vii) Satisfactory Working : Supplier should have sucessfully supplied clad plates against 2 such commercial orders as on the date of enquiry.			
	viii) All the facilities required for manufacturing of cladded tubesheet i.e explosion bonding, shall be readily available with the vendor. Ex: Normalizing and tempering facility, Ultrasonic test facility,Machining facility etc.			
	All the above criteria 3(a) (i) to 3(a) (viii) must be combinedly met by the vendor against atleast two supply reference of cladded tubesheets.			
	(b) The supplier meeting all the above criteria as 3 (a) (i) to 3 (a) (viii) shall furnish details of such supplies only as indicated above (sl no 3 (a)) including equipment (Heat Exchanger) Manufacturer's Name, date of supply (in DDMMYY format), Size, Materail, Quantity and full contact details of equipment Manufacturer (including Mobile no and e-Mail ID). OR Heat Exchanger Manufacturer's certificate (in English) containing the supply details as above both 3(a) & 3 (b), Contact details [E-Mail ID, Land line/Mobile No. and complete address of Heat exchanger Manufacturer may be furnished. Vendors who have already supplied Cladded tubesheets (for Heat exchangers) to BHEL-Hyd are exempted from furnishing the above documents if their supply records are available with BHEL. However such supplies have to meet all other requirements of this PQC. Note : Suppliers shall furnish minimum 2 and maximum upto 6 number of latest customer reference details as indicated above in the attached Annexure-I. Details furnished in any other format shall not be considered. All the documents shall be furnished only in English. Documents furnished in other languages will not be considered for further evaluation.			
4	(c) BHEL reserves the right to cross verify with the above such customers and satisfy itself with reference to the claims of the supplier. If the information furnished by the supplier is not found satisfactory, the offer will be technically rejected.			
5	Offers without the requirement as above 3(a) & 3(b) will not be technically evaluated by BHEL. Further, no correspondence in this matter will be entertained.			
6	The vendors shall furnish the detailed process of manufacturing and testing procedures along with the offer if requested.			
7	List of BHEL qualified bidders may be forwarded to BHEL's End Customer for their review and approval. The list finalized by BHEL's End Customer shall be final and binding.			
8	BHEL team may carry out vendor evaluation/assesment(incase of a new vendor)by a visit to vendor works for qualifying /rejecting the technical bid based on the findings of the visit.			

Package-2

9	Vendors to submit their bid in 2- part system, i.e. Part-I shall consists of Pre-Qualification Criteria along with the required documnets and Techno-commercial bids and Part-II shall consists of Price Bid. Offers failing to meet prequalification part will not be considered for further evaluation.			
---	---	--	--	--

Package-2

Annexure-1							
Heat Exchanger SS clad Carbon Steel tubesheet Reference details							
Ref project S.no	Base Material/Clad Material	Base material thickness min 20mm and above	OD (min 100) mm	Supply date DDMMYYYY	Heat exchanger Manufacturer details		
					Supplied to (Manufacturer's name)	Contact person	E-Mail id &Phone no
1							
2							
3							
4							
5							
6							

Note:

- a) Reference list shall be submitted in the above format only.
Vendors are requested to fill the above and submit along with PreQualification Criteria(PQC).Details mentioned above only are considered for PQC evaluation.
- b) wherever details are not available,vendor to mention as "NA"
- c) Reference project CS with SS clad tubesheet material shall be SA240 S32750 /TP316/316L/304/304L/321/321L
- d) Reference project Cladded tubesheet OD shall be 100 mm and above. Other Cladded tubesheets shall be considered as INVALID Reference.
- e) Reference project Clad tubesheet total thickness (clad+base metal)shall be 23 mm and above.
- f) Clause no 3(a) (i) to 3(a) (ix) of PQC must be combinedly met by the vendor against atleast two supply references of Carbon Steel with SS Cladded tubesheet. Minimum 01 and Maximum of 06 such reference shall be mentioned in the above table.

Package-2



BHARAT HEAVY ELECTRICALS
LIMITED
R.C.PURAM, HYDERABAD

STANDARD QUALITY PLAN FOR VENDOR ITEMS

ITEM: CLADDED TUBE PLATE (SA 266 GR.2 + SA 240 S32750)
LATEST ASME EDITION SHALL BE FOLLOWED
BHEL DRAWING: 41668006079-S00-R00
PROJECT: M-HN-1011 CB& I/TOYO

QP. NO: HY/QA/VSQP/TCMO/009/ DUPLEX CLAD
REV. NO. : 00
DATE: 14.02.2022
PAGE 1 OF 3

SL NO	COMPONENT & OPERATIONS	CHARACTERISTICS	CLASS	TYPE OF CHECK	QUANTUM OF CHECK	REF DOCUMENT	ACCEPTANCE NORMS	FORMAT OF RECORD	*D	AGENCY			REMARKS
										P	W	V	
1.0 RAW MATERIAL													
1.1	BASE MATERIAL	CHEMICAL COMPOSITION	MAJOR	CHEMICAL	AS PER SPEC.	SA 266 Gr.2	SA 266 Gr.2	SUPPLIER'S TC	✓	2		1,3	C<= 0.25% INCLUDING IGC
1.2		REVIEW OF HEAT TREATMENT CHART	MAJOR	HT	100%	SA 266 Gr.2	SA 266 Gr.2	HT CHART	✓	2		1,3	
1.3		MECHANICAL PROPERTIES	MAJOR	MECH.	AS PER SPEC.	SA 266 Gr.2	SA 266 Gr.2	SUPPLIER'S TC	✓	2		1,3	
1.4		IMPACT TESTING @ -46 Deg C	MAJOR	MECH.	AS PER SPEC.	SA 266 Gr.2	SA 266 Gr.2, DRAWING	SUPPLIER'S TC	✓	2		1,3	Avg of 3 Sample
1.5		UT EXAM	MAJOR	NDE	100%	SA 388	CL 3.3.4 OF ASME SEC VIII DEV 2	SUPPLIER'S TC	✓	2		1,3	
1.6		NACE COMPLIANCE NACE MR 0103	MAJOR	REVIEW	100%	SA 266 Gr.2, DRAWING	SA 266 Gr.2, DRAWING	NACE COMPLICACNE TC	✓	2		1,3	
1.7	CLADDED MATERIAL	CHEMICAL COMPOSITION	MAJOR	CHEMICAL	AS PER SPEC.	SA 240 S32750	SA 240 S32750	SUPPLIER'S TC	✓	2		1,3	INCLUDING IGC
1.8		MECHANICAL PROPERTIES	MAJOR	MECH.	AS PER SPEC.	SA 240 S32750	SA 240 S32750	SUPPLIER'S TC	✓	2		1,3	
1.9	PROCESS INSPECTION	UT EXAM ON CLADDED TUBE PLATE (FROM THE CLAD SURFACE)	MAJOR	NDE	100%	SA 578 ,DRAWING	SA 578 LEVEL -C , DRAWING	NDE REPORT	✓	2	1,3		Note-1 & 2
1.10		CHECK FOR BOND BETWEEN CLADDING AND BASE METAL	MAJOR	SHEAR TEST	ONE SAMPLE	DRAWING	DRAWING	IR	✓	2	1,3		
1.11		VISUAL EXAM AND DIMENSIONS	MAJOR	VISUAL & MEASURT.	100%	DRAWING	DRAWING	IR	✓	2	1,3		
1.12		FLATNESS	MAJOR	MEASRT.	100%	DRAWING	DRAWING	IR	✓	2	1,3		
1.12		VERIFICATION OF TCS, IDENTIFICATION OF MATERIAL FOR COMPLETION AS PER DRAWING & QP	MAJOR	VISUAL	100%	DRAWING & QP	DRAWING & QP	SUPPLIER'S TC,IR		2		1,3	
1.13	PACKING AND MARKING	MAJOR	VISUAL	100%	P.O.	P.O.	IR	✓	2		1,3		

LEGEND:

P: - PERFORM, W: - WITNESS, V: - VERIFICATION,
INDICATING 1: - BHEL / BHEL NOMMNATED INSPECTION AGENCY, 2: - VENDOR / SUB VENDOR 3. END CUSTOMER /END CUSTOMER TPIA AS APPROPRIATE AGAINST EACH COMPONENT / CHARACTERISTICS UNDER THE COLUMNS P, W & V.

* D: RECORDS IDENTIFIED WITH TICK (✓) SHALL BE ESSENTIALLY INCLUDED IN QA DOCUMENTATION.

PREPARED BY:

ALOK BEHERA
DY.MGR/ QA

REVIEWED BY:

B. ASHOK KUMAR
AGM/QA

APPROVED BY:

B. ASHOK KUMAR
AGM/QA

Package-2



 BHARAT HEAVY ELECTRICALS LIMITED R.C.PURAM, HYDERABAD		STANDARD QUALITY PLAN FOR VENDOR ITEMS						QP. NO: HY/QA/VSQP/TCMO/009/ DUPLEX CLAD REV. NO. : 00 DATE: 14.02.2022 PAGE 2 OF 3					
		ITEM: CLADDED TUBE PLATE (SA 266 GR.2 + SA 240 S32750) LATEST ASME EDITION SHALL BE FOLLOWED BHEL DRAWING: 41668006079-S00-R00 PROJECT: M-HN-1011 CB& I/TOYO											
SL NO	COMPONENT & OPERATIONS	CHARACTERISTICS	CLASS	TYPE OF CHECK	QUANTUM OF CHECK	REF DOCUMENT	ACCEPTANCE NORMS	FORMAT OF RECORD	*D	AGENCY			REMARKS
										P	W	V	
1.14	DESPATCH	DESPATCH (PHOTOGRAPHS SHALL BE INCLUDED)	MAJOR	VISUAL	100 %	P.O	P.O	PHOTOGRAHS	✓	2			

NOTES:

1. CLADDING SHALL BE INTEGRALLY AND CONTINOUS BONDED TO BASE MATERIAL AND CLADDING REQUIRED ON ONE SIDE ONLY.
2. NO REPAIR BY WELDING IS PERMITTED.

NOTES FOR INSPECTOR - TPIA

1. TPIA TO CHECK THE LATEST VERSION OF STANDARDS/DRAWINGS /TOLERANCES ETC TO BE MENTIONED IN QUALITY PLAN/DRAWING. THIS QP SHOULD BE READ ALONG WITH BHEL SPEC, BHEL DRAWINGS / APPROVED DRAWINGS, DATA SHEET, BOM AND PO.
2. ONLY LEVEL II & ABOVE QUALIFIED PERSON IN RESPECTIVE NDE TO VERIFY OR WITNESS THE NDT TEST REPORT/RESULTS
3. INSPECTOR TO ENSURE THAT DOCUMENTS (QUALITY PLAN, DRAWINGS, DATA SHEET, PURCHASE SPECIFICATIONS, ETC) ARE AVAILABLE AS PER PURCHASE ORDER BEFORE STARTING THE INSPECTION.
4. TPIA TO REVIEW ONLY THE ORIGINAL TEST CERTIFICATES ISSUED BY THIRD PARTY LABORATORIES OR SUPPLIERS.
5. INSPECTION REPORTS SHALL BE SUBMITTED WITH A REMARK THAT ' COMPARED WITH ORIGINAL TEST CERTIFICATE. REVIEWED, VERIFIED AND FOUND IN ORDER '. TPIA TO ENSURE THE SAME.
6. INSPECTOR TO ENSURE USE OF VALID AND CALIBRATED MEASURING INSTRUMENTS AND EQUIPMENT.
7. TPIA SHALL ENSURE THAT MATERIAL TEST CERTIFICAE & TRACEABILITY RECORDS ARE AVAILABLE FOR USE OF CORRECT MATERIAL
8. QUALIFICATION OF EQUIPMENT, PROCESS & PERSONNEL FOR SPECIAL PROCESSES LIKE WELDING, BRAZING, PAINTING & METAL COATING ETC.
9. TPIA TO ENDORSE ON ALL CERTIFICATES WITH COMMENTS (WITNESSED OR VERIFIED) AS PER QUALITY PLAN
10. TPIA SHALL ENSURE THAT LOG SHEETS CONTAIN ACTUAL MEASURED VALUES INSTEAD OF SAYING OK/NOT OK.
11. COMPLETE INSPECTION AND TEST DOCUMENTATION WHICHEVER IS IDENTIFIED WITH (v) UNDER COLUMN D OF APPROVED QULAITY PLAN SHALL BE ENCLOSED WITH THE INSPECTION REPORT. ALL TEST CERTIFICATES/ REPORTS REVIEWED AND CERTIFIED BY BHEL/TPI SHALL BE SUBMITTED TO BHEL AS DOCUMENTATION PACKAGE
12. ORIGINAL COPIES OF ALL INSPECTION AND TEST DOCUMENTS AUTHENTICATED BY TPIA SHALL BE SUBMITTED.



LEGEND: P: - PERFORM, W: - WITNESS, V: - VERIFICATION, INDICATING 1: - BHEL / BHEL NOMMNATED INSPECTION AGENCY, 2: - VENDOR / SUB VENDOR 3. END CUSTOMER /END CUSTOMER TPIA AS APPROPRIATE AGAINST EACH COMPONENT / CHARACTERISTICS UNDER THE COLUMNS P, W & V. * D: RECORDS IDENTIFIED WITH TICK (✓) SHALL BE ESSENTIALLY INCLUDED IN QA DOCUMENTATION.	PREPARED BY:  ALOK BEHERA DY.MGR/ QA	REVIEWED BY:  B. ASHOK KUMAR AGM/QA	APPROVED BY:  B. ASHOK KUMAR AGM/QA
	Format no. : HYQA/QP/VSQP Rev.02		

Package-2

 BHARAT HEAVY ELECTRICALS LIMITED R.C.PURAM, HYDERABAD		STANDARD QUALITY PLAN FOR VENDOR ITEMS						QP. NO: HY/QA/VSQP/TCMO/009/ DUPLEX CLAD REV. NO. : 00 DATE: 14.02.2022 PAGE 3 OF 3					
		ITEM: CLADDED TUBE PLATE (SA 266 GR.2 + SA 240 S32750) LATEST ASME EDITION SHALL BE FOLLOWED BHEL DRAWING: 41668006079-S00-R00 PROJECT: M-HN-1011 CB& I/TOYO											
SL NO	COMPONENT & OPERATIONS	CHARACTERISTICS	CLASS	TYPE OF CHECK	QUANTUM OF CHECK	REF DOCUMENT	ACCEPTANCE NORMS	FORMAT OF RECORD	*D	AGENCY			REMARKS
										P	W	V	

GENERAL NOTES

- BHEL RESERVES THE RIGHT FOR CONDUCTING REPEAT TEST, IF REQUIRED.
- BHEL APPROVED INSPECTION ENGINEERS TO BE DEPLOYED FOR INSPECTION.
- DRAWING / DATA SHEET SHALL PREVAIL OVER QUALITY PLAN IN CASE OF ANY CONTRADICTION BETWEEN QUALITY PLAN AND DRAWING / DATA SHEET.
- ALL TEST REPORTS SHALL BE PROVIDED AS PER PRESCRIBED FORMATS IN BHEL SPEC.
- ANY OTHER TESTS/ CHECKS INDICATED IN SPECIFICATION, P.O., OR DRAWING & ANY ADDITIONAL CHECKS ENVISAGED BY BHEL/TPI TO ENSURE WORKMANSHIP, FINISH, AESTHETICS, ETC. SHALL ALSO BE CONDUCTED AND WITNESSED/VERIFIED BY BHEL /TPI / CUSTOMER AS REQUIRED

LEGEND: P: - PERFORM, W: - WITNESS, V: - VERIFICATION, INDICATING 1: - BHEL / BHEL NOMMNATED INSPECTION AGENCY, 2: - VENDOR / SUB VENDOR 3. END CUSTOMER /END CUSTOMER TPIA AS APPROPRIATE AGAINST EACH COMPONENT / CHARACTERISTICS UNDER THE COLUMNS P, W & V. * D: RECORDS IDENTIFIED WITH TICK (✓) SHALL BE ESSENTIALLY INCLUDED IN QA DOCUMENTATION.	PREPARED BY:  ALOK BEHERA DY.MGR/ QA	REVIEWED BY:  B. ASHOK KUMAR AGM/QA	APPROVED BY:  B. ASHOK KUMAR AGM/QA
	Format no. : HYQA/QP/VSQP Rev.02		

Package 3&4

12.5/

DRG. NO. 3-166-80-01789

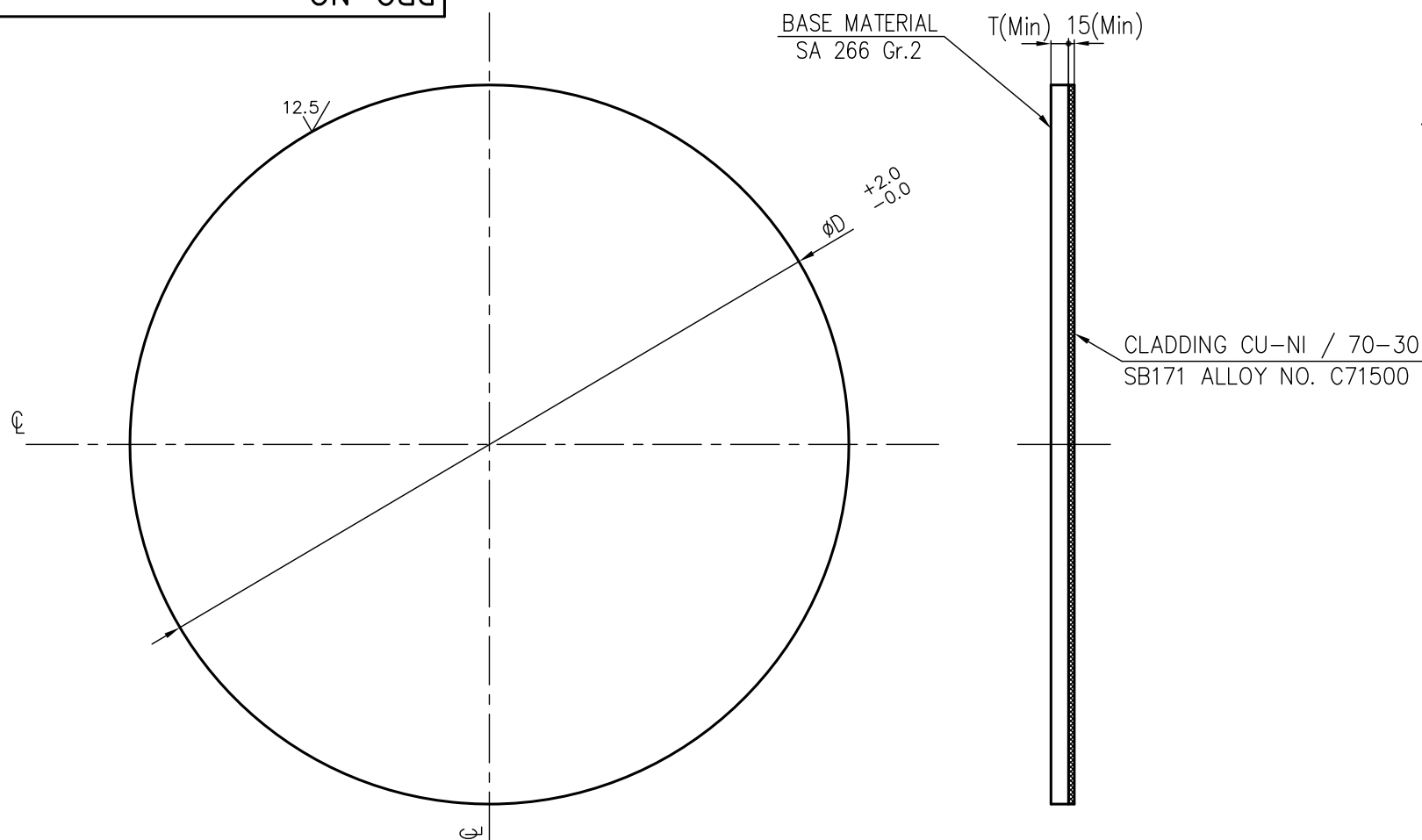

NOTE :-

1. MATERIAL :-
 - a) BASE MATERIAL SHALL BE AS PER SA 266 Gr.2 OF ASME SEC.II PART-'A' LATEST EDITION AS PER INDENT.
 - b) CLADDED MATERIAL SHALL BE AS PER SB 171 C71500 OF ASME SEC.II PART 'B' LATEST EDITION AS PER INDENT.
2. CLADDING SHALL BE INTEGRALLY AND CONTINUOUSLY BONDED TO THE BASE MATL. AND CLADDING REQUIRED ON ONE SIDE ONLY.
3. BOND BETWEEN CLADDING AND THE BASE METAL SHALL BE CHECKED FOR A MINIMUM STRENGTH OF 8.5 kgf/sq.mm IN SHEAR BY CONDUCTING SHEAR TEST.
4. CLAD PLATE SHALL BE ULTRASONICALLY EXAMINED FROM THE CLAD SURFACE AS PER SA 578. SCANNING SHALL BE 100 % OF THE PLATE SURFACE. ACCEPTANCE STD. SHALL BE LEVEL-A OF B432.
5. BASE FORGING MATERIAL TO BE SUPPLIED IN NORMALISED & TEMPERED CONDITION AND CARBON CONTENT SHALL NOT BE GREATER THAN 0.25 %.
6. BASE FORGING SHALL BE ULTRASONICALLY TESTED AS PER SA 388 OF ASME SEC-V LATEST CODE AND ADDENDA, ACCEPTANCE STANDARD SHALL BE AS PER CLAUSE 3.3.4 OF ASME SECTION VIII DIV-2 CODE & ADDENDA AS PER INDENT.
7. BASE MATERIAL TO BE CHARPY V-NOTCH IMPACT TESTED AND MINIMUM IMPACT ENERGY REQUIRED FOR AVERAGE OF 3 SPECIMENS SHALL BE 20J MINIMUM IMPACT ENERGY PERMITTED IS 16J FOR ONE SPECIMEN ONLY OF A SET.IMPACT TEST TEMPERATURE SHALL BE -46°C.
8. FLATNESS ON THE CLADDED SURFACE SHOULD BE LIMITED TO 1 mm ON ENTIRE SURFACE OF TUBE PLATE.THE SAME SHOULD BE INSPECTED AND CERTIFIED BY BHEL TPIA.
9. INSPECTION AND CERTIFICATION BY BHEL TPIA.
10. THE TOLERANCE ON MATERIAL SHALL BE LIMITED TO PLUS 2.0 mm,MINUS 0.0 mm.

VAR.No.	DESCRIPTION	D	T	MATERIAL CODE	Qty	WT(Kg)
01	CLADDED TUBE SHEET(FIXED)	868	65	HE9718634185	2	382
02	CLADDED TUBE SHEET (FLOATING)	790	65	HE9718634193	2	317
04	CLADDED TUBE SHEET(FIXED)	681	50	HE9718633146	1	192
05	CLADDED TUBE SHEET (FLOATING)	595	50	HE9718633154	1	147

VAR.No.	DESCRIPTION	L	B	THK	QTY	MATERIAL CODE	WT(Kg)
03	CLADDED MOCK UP PIECE	150	150	65+15	3	HE9714714079	14.5
06	CLADDED MOCK UP PIECE	150	150	50+15	3	HE9718633162	12

TYPE OF PRODUCT OR NAME OF CUSTOMER/PROJECT						DRN.	NAME SAPTARSHI	SIGN. SAPTARSHI	DATE 05.02.2022	NO.OF VAR.	
BHARAT HEAVY ELECTRICALS LTD. HYDERABAD						CHD.	A.K. SAHOO	A.K. SAHOO	05.02.2022	NA	
						APPD.	K.K.K.	K.K.K.	05.02.2022		
REV.	DATE	ALTERED	CHECKED	APPD	DEPT. HEE	GRADE OF TOL.DIM. C/M/F	SCALE NTS	WEIGHT (KG)	REF. TO ASSY DRG. NA	ITEM NO. NA	NO.OF ITEMS NA
ZONE					CODE 405						
TITLE						CARD CODE	DRAWING NO.		REV.		
Cu- Ni CLADDED TUBE PLATE (FIXED & FLOATING TUBESHEET)							3-166-80-01789		00		
							SHEET No. 1	NO OF SHEETS 1			

INVENTORY NO. SIGN. AND DATE REF. DRG. NO. THE INFORMATION ON THIS DOCUMENT IS THE PROPERTY OF BHARAT HEAVY ELECTRICALS LIMITED. IT MUST NOT BE USED DIRECTLY OR INDIRECTLY IN ANY WAY DETRIMENTAL TO THE INTEREST OF THE COMPANY

PRE-QUALIFICATION CRITERIA(PQC)				
CLADDED TUBESHEET (Document no: D41668006077, Rev 00)				
S.No.	BHEL Requirement	Vendor's Confirmation	Deviation if Any	Remarks
1	All the suppliers need to submit this document i.e. titled pre-qualification criteria and furnish required information along with offer.			
2	<p>a) Name, address, e-mail id, contact no.etc. of manufacturing mill for Clad Plate.</p> <p>b) Name, address, e-mail id, contact no.etc. of authourised agency / trading house quoting on behalf of manufacturing mill. In case offer is received from authourised agency / trading house, the following requirements shall be full filled. i) Valid letter of authorisation and copy of agreement to be enclosed with offer. ii) The offer shall be either from the authorised agency or from the manufacturer directly. In case of BHEL receiving offer from both, then offer from manufaturer will only be considered. Offer from an unauthorised agency / entity on behalf of any vendor shall be summarily rejected. iii) Name, address, e-mail id, contact no.etc. of entity on whom order to be released in case of L1 shall be clearly indicated.</p>			<p>Bidder to tick the below as applicable: -OEM. -Authorized agency/trading house. If so 2(b) requirements to be met.</p>
3	<p>Supplier to confirm/provide the following criteria/documents for evaluation of offer.</p> <p>(a) The supplier shall have the proven experience in manufacturing and supply of cladded plate for any heat exchangers / pressure vessels etc as mentioned below.</p> <p>i) Base Material : Carbon Steel(ASME Grade)</p> <p>ii) Base material min thickness 20 mm and above and Diameter Min 100 mm</p> <p>iii) Clad material : Ferrous or Non-Ferrous(ASME Grade)</p> <p>iv) Clad material min thickness 3mm and above.</p> <p>v) Application: Any Heat exchanger / pressure vessel</p> <p>v) Service: Thermal power plant/Nuclear power plant/Refineries/Fertilizers etc</p> <p>vii) Satisfactory Working : Supplier should have sucessfully supplied clad plates against 2 such commercial orders as on the date of enquiry.</p> <p>viii) All the facilities required for manufacturing of cladded tubesheet i.e explosion bonding shall be readily available with the vendor and also shall meet the requirements of cladded plate specification .</p> <p>All the above criteria 3(a) (i) to 3(a) (viii) must be combinedly met by the vendor against atleast two supply reference of cladded tubesheets.</p> <p>(b) The supplier meeting all the above criteria as 3 (a) (i) to 3 (a) (viii) shall furnish details of such supplies only as indicated above (sl no 3 (a)) including equipment / vessel Manufacturer's Name, date of supply (in DDMMYY format), Size, Material, Quantity and full contact details of equipment Manufacturer (including Mobile no and e-Mail ID). OR Heat Exchanger / vessel Manufacturer's certificate (in English) containing the supply details as above both 3(a) & 3 (b), Contact details [E-Mail ID, Land line/Mobile No. and complete address of Heat exchanger Manufacturer may be furnished. Vendors who have already supplied Cladded tubesheets (for Heat exchangers) to BHEL-Hyd are exempted from furnishing the above documents if their supply records are available with BHEL. However such supplies have to meet all other requirements of this PQC. Note : Suppliers shall furnish minimum 2 and maximum upto 6 number of latest customer reference details as indicated above in the attached Annexure-I. Details furnished in any other format shall not be considered. All the documents shall be furnished only in English. Documents furnished in other langauges will not be considered for further evaluation.</p>			
4	(c) BHEL reserves the right to cross verify with the above such customers and satisfy itself with reference to the claims of the supplier. If the information furnished by the supplier is not found satisfactory, the offer will be technically rejected.			
5	Offers without the requirement as above 3(a) & 3(b) will not be technically evaluated by BHEL. Further, no correspondence in this matter will be entertained.			
6	The vendors shall furnish the detailed process of manufacturing and testing procedures along with the offer if requested.			
7	List of BHEL qualified bidders may be forwarded to BHEL's End Customer for their review and approval. The list finalized by BHEL's End Customer shall be final and binding.			
8	BHEL team may carry out vendor evaluation/assesment(incase of a new vendor)by a visit to vendor works for qualifying /rejecting the technical bid based on the findings of the visit.			
9	Vendors to submit their bid in 2- part system, i.e. Part-I shall consists of Pre-Qualification Criteria along with the required documnets and Techno-commercial bids and Part-II shall consists of Price Bid. Offers failing to meet prequalification part will not be considered for further evaluation.			

Annexure-1								
Heat Exchanger Cladded tubesheet Reference details								
Ref project S.no	Base Material	Clad Material	Base material OD (Min. 100mm & above) and thickness(Min. 20mm & above)	Clad material OD (Min. 100mm & above) and thickness(Min. 3mm & above)	Supply date DDMMYYYY	Heat exchanger Manufacturer details		
						Supplied to (Manufacturer's name)	Contact person	E-Mail id &Phone no
1								
2								
3								
4								
5								
6								

- Note:
- a) Reference list shall be submitted in the above format only.
Vendors are requested to fill the above and submit along with PreQualification Criteria(PQC).Details mentioned above only are considered for PQC evaluation.
 - b) wherever details are not available,vendor to mention as "NA"
 - c) Reference project Cladded tubesheet OD shall be 100 mm and above. Other Cladded tubesheets shall be considered as INVALID Reference.
 - d) Reference project Clad tubesheet total thickness (clad+base metal)shall be 23 mm and above.
Minimum 01 and Maximum of 06 such reference shall be mentioned in the above table. (For ease of evaluation)



BHARAT HEAVY ELECTRICALS
LIMITED
R.C.PURAM, HYDERABAD

STANDARD QUALITY PLAN FOR VENDOR ITEMS

ITEM: CLADDED TUBE PLATE (SA 266 GR.2+ Cu-Ni)
LATEST ASME EDITION SHALL BE FOLLOWED
BHEL DRAWING: 31668001789-S00-R00
PROJECT: M-HN-1011 CB& I/TOYO

QP. NO: HYQA/VSQP/2017-18/HE/120/M-HN-1011
BARAUNI
REV. NO. : 00
DATE: 14.02.2022
PAGE 1 OF 3

Package 3&4

SL NO	COMPONENT & OPERATIONS	CHARACTERISTICS	CLASS	TYPE OF CHECK	QUANTUM OF CHECK	REF DOCUMENT	ACCEPTANCE NORMS	FORMAT OF RECORD	*D	AGENCY			REMARKS
										P	W	V	
1.0 RAW MATERIAL													
1.1	BASE MATERIAL	CHEMICAL COMPOSITION	MAJOR	CHEMICAL	AS PER SPEC.	SA 266 Gr.2	SA 266 Gr.2	SUPPLIER'S TC	✓	2		1,3	C<= 0.25%
1.2		REVIEW OF HEAT TREATMENT CHART	MAJOR	HT	100%	SA 266 Gr.2	SA 266 Gr.2	HT CHART	✓	2		1,3	
1.3		MECHANICAL PROPERTIES	MAJOR	MECH.	AS PER SPEC.	SA 266 Gr.2	SA 266 Gr.2	SUPPLIER'S TC	✓	2		1,3	
		IMPACT TESTING @ -46 Deg C	MAJOR	MECH.	AS PER SPEC.	SA 266 Gr.2	SA 266 Gr.2, DRAWING	SUPPLIER'S TC	✓	2		1,3	Avg of 3 Sample
1.4		UT EXAM	MAJOR	NDE	100%	SA 388	CL 3.3.4 OF ASME SEC VIII DEV 2	SUPPLIER'S TC	✓	2		1,3	
1.5	CLADDED MATERIAL	CHEMICAL COMPOSITION	MAJOR	CHEMICAL	AS PER SPEC.	SB171 C71500	SB171 C71500	SUPPLIER'S TC	✓	2		1,3	
1.6		MECHANICAL PROPERTIES	MAJOR	MECH.	AS PER SPEC.	SB171 C71500	SB171 C71500	SUPPLIER'S TC	✓	2		1,3	
1.7		UT EXAM	MAJOR	NDE	100%	SA 578 ,DRAWING	SA 578 L-B	SUPPLIER'S TC/IR	✓	2		1,3	
1.8	PROCESS INSPECTION	UT EXAM ON CLADDED TUBE PLATE (FROM THE CLAD SURFACE)	MAJOR	NDE	100%	ASTM B 432 & DRAWING	ASTM B 432 (LEVEL -A) , DRAWING	NDE REPORT	✓	2	1,3		Note-1 & 2
1.9		CHECK FOR BOND BETWEEN CLADDING AND BASE METAL	MAJOR	SHEAR TEST	ONE SAMPLE	DRAWING	DRAWING	IR	✓	2	1,3		
1.10		VISUAL EXAM AND DIMENSIONS	MAJOR	VISUAL & MEASURT.	100%	DRAWING	DRAWING	IR	✓	2	1,3		
1.11		FLATNESS	MAJOR	MEASRT.	100%	DRAWING	DRAWING	IR	✓	2	1,3		
1.12		VERIFICATION OF TCS, IDENTIFICATION OF MATERIAL FOR COMPLETION AS PER DRAWING & QP	MAJOR	VISUAL	100%	DRAWING & QP	DRAWING & QP	SUPPLIER'S TC,IR		2		1,3	
1.13		PACKING AND MARKING	MAJOR	VISUAL	100%	P.O.	P.O.	IR	✓	2		1,3	

LEGEND:

P: - PERFORM, W: - WITNESS, V: - VERIFICATION, INDICATING 1: - BHEL / BHEL NOMMNATED INSPECTION AGENCY, 2: - VENDOR / SUB VENDOR 3. END CUSTOMER /END CUSTOMER TPIA AS APPROPRIATE AGAINST EACH COMPONENT / CHARACTERISTICS UNDER THE COLUMNS P, W & V.

* D: RECORDS IDENTIFIED WITH TICK (✓) SHALL BE ESSENTIALLY INCLUDED IN QA DOCUMENTATION.

PREPARED BY:

ALOK BEHERA
DY.MGR/ QA

REVIEWED BY:

B. ASHOK KUMAR
AGM/QA

APPROVED BY:

B. ASHOK KUMAR
AGM/QA

		BHARAT HEAVY ELECTRICALS LIMITED R.C.PURAM, HYDERABAD		STANDARD QUALITY PLAN FOR VENDOR ITEMS				QP. NO: HYQA/VSQP/2017-18/HE/120/M-HN-1011 BARAUNI REV. NO. : 00 DATE: 14.02.2022 PAGE 2 OF 3					
				ITEM: CLADDED TUBE PLATE (SA 266 GR.2+ Cu-Ni) LATEST ASME EDITION SHALL BE FOLLOWED BHEL DRAWING: 31668001789-S00-R00 PROJECT: M-HN-1011 CB& I/TOYO									
SL NO	COMPONENT & OPERATIONS	CHARACTERISTICS	CLASS	TYPE OF CHECK	QUANTUM OF CHECK	REF DOCUMENT	ACCEPTANCE NORMS	FORMAT OF RECORD	*D	AGENCY			REMARKS
										P	W	V	
1.14	DESPATCH	DESPATCH (PHOTOGRAPHS SHALL BE INCLUDED)	MAJOR	VISUAL	100 %	P.O	P.O	PHOTOGRAHS	✓	2			



NOTES:

1. CLADDING SHALL BE INTEGRALLY AND CONTINOUS BONDED TO BASE MATERIAL AND CLADDING REQUIRED ON ONE SIDE ONLY.
2. NO REPAIR BY WELDING IS PERMITTED.

Package 3&4

NOTES FOR INSPECTOR - TPIA

1. TPIA TO CHECK THE LATEST VERSION OF STANDARDS/DRAWINGS /TOLERANCES ETC TO BE MENTIONED IN QUALITY PLAN/DRAWING. THIS QP SHOULD BE READ ALONG WITH BHEL SPEC, BHEL DRAWINGS / APPROVED DRAWINGS, DATA SHEET, BOM AND PO.
2. ONLY LEVEL II & ABOVE QUALIFIED PERSON IN RESPECTIVE NDE TO VERIFY OR WITNESS THE NDT TEST REPORT/RESULTS
3. INSPECTOR TO ENSURE THAT DOCUMENTS (QUALITY PLAN, DRAWINGS, DATA SHEET, PURCHASE SPECIFICATIONS, ETC) ARE AVAILABLE AS PER PURCHASE ORDER BEFORE STARTING THE INSPECTION.
4. TPIA TO REVIEW ONLY THE ORIGINAL TEST CERTIFICATES ISSUED BY THIRD PARTY LABORATORIES OR SUPPLIERS.
5. INSPECTION REPORTS SHALL BE SUBMITTED WITH A REMARK THAT ' COMPARED WITH ORIGINAL TEST CERTIFICATE. REVIEWED, VERIFIED AND FOUND IN ORDER '. TPIA TO ENSURE THE SAME.
6. INSPECTOR TO ENSURE USE OF VALID AND CALIBRATED MEASURING INSTRUMENTS AND EQUIPMENT.
7. TPIA SHALL ENSURE THAT MATERIAL TEST CERTIFICAE & TRACEABILITY RECORDS ARE AVAILABLE FOR USE OF CORRECT MATERIAL
8. QUALIFICATION OF EQUIPMENT, PROCESS & PERSONNEL FOR SPECIAL PROCESSES LIKE WELDING, BRAZING, PAINTING & METAL COATING ETC.
9. TPIA TO ENDORSE ON ALL CERTIFICATES WITH COMMENTS (WITNESSED OR VERIFIED) AS PER QUALITY PLAN
10. TPIA SHALL ENSURE THAT LOG SHEETS CONTAIN ACTUAL MEASURED VALUES INSTEAD OF SAYING OK/NOT OK.
11. COMPLETE INSPECTION AND TEST DOCUMENTATION WHICHEVER IS IDENTIFIED WITH (v) UNDER COLUMN D OF APPROVED QULAITY PLAN SHALL BE ENCLOSED WITH THE INSPECTION REPORT. ALL TEST CERTIFICATES/ REPORTS REVIEWED AND CERTIFIED BY BHEL/TPI SHALL BE SUBMITTED TO BHEL AS DOCUMENTATION PACKAGE
12. ORIGINAL COPIES OF ALL INSPECTION AND TEST DOCUMENTS AUTHENTICATED BY TPIA SHALL BE SUBMITTED.



<p>LEGEND: P: - PERFORM, W: - WITNESS, V: - VERIFICATION, INDICATING 1: - BHEL / BHEL NOMMNATED INSPECTION AGENCY, 2: - VENDOR / SUB VENDOR 3. END CUSTOMER /END CUSTOMER TPIA AS APPROPRIATE AGAINST EACH COMPONENT / CHARACTERISTICS UNDER THE COLUMNS P, W & V. * D: RECORDS IDENTIFIED WITH TICK (✓) SHALL BE ESSENTIALLY INCLUDED IN QA DOCUMENTATION.</p>	<p>PREPARED BY:</p> <div style="text-align: center;">  ALOK BEHERA DY.MGR/ QA </div>	<p>REVIEWED BY:</p> <div style="text-align: center;">  B. ASHOK KUMAR AGM/QA </div>	<p>APPROVED BY:</p> <div style="text-align: center;">  B. ASHOK KUMAR AGM/QA </div>
Format no. : HYQA/QP/VSQP Rev.02			

		BHARAT HEAVY ELECTRICALS LIMITED R.C.PURAM, HYDERABAD		STANDARD QUALITY PLAN FOR VENDOR ITEMS				QP. NO: HYQA/VSQP/2017-18/HE/120/M-HN-1011 BARAUNI REV. NO. : 00 DATE: 14.02.2022 PAGE 3 OF 3					
				ITEM: CLADDED TUBE PLATE (SA 266 GR.2+ Cu-Ni) LATEST ASME EDITION SHALL BE FOLLOWED BHEL DRAWING: 31668001789-S00-R00 PROJECT: M-HN-1011 CB& I/TOYO									
SL NO	COMPONENT & OPERATIONS	CHARACTERISTICS	CLASS	TYPE OF CHECK	QUANTUM OF CHECK	REF DOCUMENT	ACCEPTANCE NORMS	FORMAT OF RECORD	*D	AGENCY			REMARKS
										P	W	V	

GENERAL NOTES

- BHEL RESERVES THE RIGHT FOR CONDUCTING REPEAT TEST, IF REQUIRED.
- BHEL APPROVED INSPECTION ENGINEERS TO BE DEPLOYED FOR INSPECTION.
- DRAWING / DATA SHEET SHALL PREVAIL OVER QUALITY PLAN IN CASE OF ANY CONTRADICTION BETWEEN QUALITY PLAN AND DRAWING / DATA SHEET.
- ALL TEST REPORTS SHALL BE PROVIDED AS PER PRESCRIBED FORMATS IN BHEL SPEC.
- ANY OTHER TESTS/ CHECKS INDICATED IN SPECIFICATION, P.O., OR DRAWING & ANY ADDITIONAL CHECKS ENVISAGED BY BHEL/TPI TO ENSURE WORKMANSHIP, FINISH, AESTHETICS, ETC. SHALL ALSO BE CONDUCTED AND WITNESSED/VERIFIED BY BHEL /TPI / CUSTOMER AS REQUIRED

Package 3&4

<p>LEGEND: P: - PERFORM, W: - WITNESS, V: - VERIFICATION, INDICATING 1: - BHEL / BHEL NOMMNATED INSPECTION AGENCY, 2: - VENDOR / SUB VENDOR 3. END CUSTOMER /END CUSTOMER TPIA AS APPROPRIATE AGAINST EACH COMPONENT / CHARACTERISTICS UNDER THE COLUMNS P, W & V. * D: RECORDS IDENTIFIED WITH TICK (✓) SHALL BE ESSENTIALLY INCLUDED IN QA DOCUMENTATION.</p>	<p>PREPARED BY:</p>  ALOK BEHERA DY.MGR/ QA	<p>REVIEWED BY:</p>  B. ASHOK KUMAR AGM/QA	<p>APPROVED BY:</p>  B. ASHOK KUMAR AGM/QA
Format no. : HYQA/QP/VSQP Rev.02			

(To be executed on Non- Judicial Stamp Paper for an appropriate value.
To be stamped as an agreement)

(For Suppliers on Unit's / Division's PMD)

ANNEXURE-II

Framework Confidentiality Agreement Cum Undertaking

This Agreement made on this the _____ day of (month) _____ 20 ____ (“Effective Date”) by and between M/s. BHARAT HEAVY ELECTRICALS LIMITED, having registered office at “BHEL House”, Siri Fort, New Delhi – 110049 (India), acting through its _____ Unit (hereinafter may be referred to as “BHEL” or “the company”).

And

M/s. _____ (address) _____
represented by authorized representative Sri _____ (herein after referred to as the “Supplier”).

The supplier and the company may, unless the context otherwise requires, hereinafter be collectively referred to as “Parties” or singly as the “Party”.

RECITALS

Whereas, BHEL is engaged in the design, engineering, manufacturing, construction, testing, commissioning and servicing of a wide range of products, systems and services for the core sectors of the economy, viz. Power, Transmission, Industry, Transportation, Renewable energy, Oil & Gas and Defence and providing associated services to varied customers in relation to which BHEL / its affiliates own valuable information of a secret and confidential nature.

Whereas the Company may, in connection with contract(s) (as defined hereunder) placed or to be placed upon the supplier, or otherwise, from time to time, make available, Technical Information as is defined hereunder.

And Whereas BHEL is willing to provide such Technical Information to the Supplier from time to time and the Supplier understands and acknowledges that such Technical Information is valuable for the Company and as such is willing to protect confidentiality of such information, subject to the terms and conditions set out hereunder.

Now therefore, in view of the foregoing premises and in consideration of the mutual covenants and agreements hereinafter set forth, the parties agree as under:

1. Definitions:

Unless the context so requires, in this Agreement, the following terms will bear the meaning ascribed to the said term in this clause.

- A. **“Contract”** means the contract entered into with a supplier and includes a Purchase Order, or a Work Order for procurement of any goods or for provision of any services.
- B. **“Effective Date”** means the date of this Agreement as mentioned in the preamble of this Agreement.
- C. **“Supplier”** includes a Contractor or a Vendor of the Company whether for supplying of goods or for providing any services under a Contract or both.
- D. **“Technical Information”** includes Drawings, and / or Product Standards and / or Specifications and / or Corporate / Plant Specifications and / or Technological Process Sheets and / or Technical Data Sheets and / or Jigs & Fixtures and / or Pattern & Dies and / or Special Gauges and / or Tools etc. Belonging to or wherein the Company has acquired from a third party a right of user and includes any improvement thereto from time to time whether carried out by the Company or by the Suppliers.
- E. **“Intended Purpose”** means the purpose for which the Technical Information is provided to the supplier under or in connection with a contract.
- F. **“Improvement”** includes any modification made to, or adaptation of, the Technical Information which enhances or is calculated to enhance the performance (Whether in terms of effectiveness or in terms of efficiency or both) of the product and / or the service to be provided by the Supplier under a Contract.

2. This Agreement shall come into force / deemed to have come into force, as the case may be, on the Effective Date; or, on the first date when the Technical Information or any part thereof is provided by BHEL to the supplier; whichever is earlier.

3. **Agreement deemed to be incorporated in each contract:** Unless and to the extent otherwise stipulated in the Contract, the conditions of this Agreement are deemed to be incorporated in all Contracts which may be entered into between the Company and the Supplier. Further, unless otherwise stipulated, the obligations under this Agreement are and will be independent of the obligations under the Contracts and such obligations of the Supplier hereunder will remain of full effect and validity notwithstanding that the period of validity of the Contract has expired by efflux of time stipulated therein; or, the contract has been discharged by performance or breach; or, the termination of the Contracts for any reason whatsoever.

4. Ownership:

4.1 The Company may, from time to time, make available to the Supplier, Technical Information on a non-exclusive basis by way of loan.

4.2 The Supplier acknowledges and agrees that all Technical Information and copies thereof that are or may be provided by the Company to the Supplier, are and shall remain the property of

BHEL or that of the concerned entity from whom BHEL has obtained the Technical Information and such Technical Information are and shall constitute trade secrets of the BHEL. Nothing in this Agreement or in any disclosures made hereunder by or on behalf of the Company shall be construed as granting upon the Supplier any patent, copyright or design or any other intellectual property rights of whatsoever description that subsists or may hereinafter exist in the Technical Information. Furthermore, nothing in this Agreement or in any disclosures made hereunder by or on behalf of the Company shall be construed as granting upon the supplier any license or right of use of such patent, copyright or design or any other intellectual property rights of whatsoever description which may now or hereafter exist in the Technical Information except for use of the Technical Information strictly in accordance with this Agreement and the contract and / or as directed in writing by the Company, solely for the Intended Purpose under the Contract.

4.3 Neither party is obligated by or under this Agreement to purchase from or provide to the other party any service or product and that any such purchase / sale of any product and / or service by one party to the other party will be governed by the Contract if any, that may be entered into by and between the Company and the Supplier.

4.4 The Supplier is / has been made well aware and acknowledges that the Technical Information being / which may be shared with it by the Company has been either generated by the Company by incurring huge investment and cost or obtained from foreign collaborators under Technical Collaboration Agreement (TCA) with stringent confidentiality conditions.

4.5 The supplier agrees and undertakes to adhere to confidentiality requirements as applicable to BHEL under a TCA and also ensure that the confidentiality requirements are adhered to by all its concerned employees or sub-contractors /suppliers (where permitted to be engaged by BHEL). Any damages, losses, expenses of any description whatsoever, arising out of or in connection with a breach of the confidentiality requirements under a TCA owing to any act or omission on the part of the supplier or its employees or sub-contractors / suppliers that is claimed by a foreign collaborator from the Company shall be wholly borne by the Supplier and it shall keep BHEL fully indemnified in this behalf. The demand by the Company shall be conclusive upon the Supplier who shall thereupon forthwith pay to the Company without demur, dispute or delay the amount as demanded without demanding any further proof thereof.

4.6 The Supplier agrees and undertakes that unless so decided and advised by the Company in writing all rights / title to any Improvement to the Technical Information shall vest in the Company. The Supplier undertakes and agrees to inform forthwith to the Company of any such Improvement made to the Technical Information and transfer all drawings / documents or other materials connected with such Improvement to the Company and also agrees to fully cooperate with the Company for protecting the Company's interests in such Improvements

in the Technical Information including but not limited to obtaining necessary protection for the intellectual property rights in such improvement, if so desired by the Company. If a question arises whether a modification amounts to improvement to the Technical Information, the same shall be decided by the Company and such decision shall be final and binding upon the supplier.

5. Use and Non – Disclosure:

5.1 Unless otherwise stipulated by the Company, all Technical Information made available to the supplier, by the Company shall be treated as Confidential irrespective of whether the same is marked or otherwise denoted to be Confidential or not.

5.2 The Supplier undertakes and agrees that the Technical Information in its possession shall be held in strict confidence and will be used strictly in accordance with this Agreement and solely for the Intended Purpose under the Contract. Use of the Technical Information for any other purpose other than Intended Purpose is prohibited.

5.3 In particular, the Supplier shall not use Technical Information or any Improvement in its possession for the manufacture or procurement of the product(s) or components or parts thereof or use the Technical Information or any portion thereof or any modification or adaptation thereof in any form to provide any product and / or service to any third party, without the prior written consent of the Company.

5.4 The Supplier shall not disclose any of such Technical Information to any third party without the prior written consent of the Company. The Supplier agrees that without prior written consent of the Company, the supplier shall not disclose to a third party about the existence of this Agreement, or of the fact that it is / was in possession of or has experience in the use of any Technical Information nor shall the Supplier share in any manner whatsoever, with a third party, the name or details of any Contract(s) awarded by the Company to it or performed by the Supplier or the scope of work thereof or share any document or correspondence by and between the Company and the supplier in or in connection with this Agreement or such Contract(s). Notwithstanding what is stated elsewhere, the overall responsibility of any breach of the confidentiality provisions under this Agreement shall rest with the Supplier.

5.5 This Supplier undertakes and agrees not to make copies or extracts of and not to disclose to other any or all of the Technical Information in its possession, except as follows:

(a) The Supplier may disclose the Technical Information to such of its officers and employees strictly to the extent as is necessary for such officer or employee for the Intended Purpose, provided that the Confidential Information (or copies thereof) disclosed shall be marked

clearly as the confidential and proprietary information of Company and that such officers and employees shall similarly be bound by undertakings of confidence, restricted use and non-disclosure in respect of the Technical Information. The Supplier shall be responsible for any breach of such confidentiality provisions by such officers and employees.

- (b) With the prior written consent of Company, the supplier may disclose for the Intended Purpose such Technical Information as is provided for in such consent to such of its professional advisers: consultants, insurers and subcontractors who shall be similarly bound by undertakings of confidence, restricted use and non-disclosure in respect of such Technical Information.
- (c) The Supplier shall not be prevented to make any disclosure required by (i) order of a court of competent jurisdiction or (ii) any competent regulatory authority or agency where such disclosure is required by law, provided that where the supplier intends to make such disclosure, it shall first consult Company and take all reasonable steps requested by it to minimize the extent of the Technical Information disclosed and to make such disclosure in confidence and also shall cooperate with the Company in seeking any protective order or any other remedy from proper authority in this matter.

6. Exceptions:

The Obligations of the Supplier pursuant to the provisions of this agreement shall not apply to any Confidential Information that:

- a) was / is known to, or in the possession of the Supplier prior to disclosure thereof by the Company;
- b) is or becomes publicly known, otherwise than as a result of a breach of this agreement by the Supplier.
- c) is developed independently of the Disclosing party by the Supplier in circumstances that do not amount to a breach of the provisions of this Agreement or the Contract;
- d) is received from a third party in circumstances that do not result in a breach of the provisions of this Agreement.

- 7. The Obligation of maintaining confidentiality of the Technical Information on each occasion, shall subsist for the entire duration during which the Technical Information / equipment is in possession of the Supplier and shall thereafter subsist for a further period of _____ years from the date when the complete Technical Information has been returned in portions on different dates, the period of ____ years will be reckoned from the date when the last portion of the Technical Information has been returned. Notwithstanding the expiry of the confidentiality obligation, the obligation of the Supplier under clause 5.4 shall continue to subsist for a further period of _____ years.

8. Warranties & Undertakings:

- a) The Supplier undertakes to ensure the due observance of the undertakings of confidence, restricted use and non-disclosure by its persons to whom it discloses or releases copies or extracts of the Technical Information.
- b) The Supplier shall keep the Technical Information or improvement made therein properly segregated and not mix up the same with any other material / documents belonging to him / it or to any other third party.
- c) The Supplier further undertakes that he / it shall not hypothecate or give on lease or otherwise alienate or do away with any of the Technical Information and / or equipment of the Company, made available to him / it, and undertakes that he / it shall hold the same as a trustee, in capacity of custodian thereof and use / utilise the same solely for the purpose of executing the contract awarded by the Company.
- d) The Supplier further undertakes that he / it shall return all the equipment and / or Technical Information as far as practicable in the same condition in which the same was made available to him / it by the Company together with any Improvement thereon and the documents connected with such Improvement, to the Company forthwith upon completion of the scope of work or contract for which such Technical Information was provided by the Company to it or as directed by the Company together with a confirmation by way of an affidavit or in such manner as directed by the Company that it has not retained any equipment and / or Technical Information / improvement thereof. In case any such equipment and / or Technical Information or thereof shall remain in his possession or is not capable of being returned, the retention and use of such Technical Information or improvement thereto shall continue to be governed by this Agreement.
- e) The Supplier undertakes to indemnify the Company for all the direct, indirect and / or consequential losses, damages, expenses whatsoever including any consequential loss of business, profits suffered by the Company owing to breach by the Supplier of its obligations under this Agreement and / or the confidentiality requirements, if any, contained in the Contract and that the Supplier hereby agrees that the decision of the Company in all such or any such matter/s shall be final and binding on the Supplier. On mere written demand of the Company, the Supplier shall forthwith and without demur or delay pay to the Company any such sum as determined by the Company as the amount of loss or damage or expense which has been suffered by the Company. The Supplier agrees that the Company shall be entitled to withhold and appropriate any amount payable to the Supplier under any Contract then existing between the Company and the Supplier, in case the Supplier fails to make payment, in terms of the written demand, within 7 days thereof. Without prejudice to the forgoing actions, in respect to any breach of this Agreement, the Company shall be entitled to take

any other action against the Supplier as per applicable laws, the Contract, Company's applicable policies, guidelines rules, procedures, etc.

9. Without prejudice to any other mode of recovery as may be available to the Company for recovery of the amount determined as due as per Clause 9 (f) hereinabove, the Company shall have a right to withhold, recovery and appropriate the amount due towards such losses, damages, expenses, from any amount due to the Supplier in respect of any other Contract (s) placed on him / it by any department / office / unit/ division of the said Company.

10. Arbitration & Conciliation:

1. Except as provided elsewhere in this contract, in case amicable settlement is not reached between the parties, in respect of any dispute or difference; arising out of the formation, breach, termination, validity or execution of the contract; or, the respective rights and liabilities of the parties; or, in relation to interpretation of any provision of the contract; or, in any manner touching upon the contract, then, either party may, by a notice in writing to the other party refer such dispute or difference to the sole arbitration of an arbitrator appointed by head of the BHEL unit issuing the contract.

The Arbitrator shall pass a reasoned award and the award of the Arbitrator shall be final and binding upon the parties.

Subject as aforesaid, the provisions of Arbitration and Conciliation Act 1996 (India) or statutory modifications or re-enactments thereof and the rules made thereunder and for the time being in force shall apply to the arbitration proceedings under this clause, the seat of arbitration shall be at Hyderabad.

The cost of arbitration shall be borne as per the award of the Arbitrator.

Subject to the arbitration in terms of clause 55, the courts at Sangareddy, Telangana State shall have exclusive jurisdiction over any matter arising out of or in connection with this contract.

Notwithstanding the existence or any dispute or differences and / or reference for the arbitration, the contractor shall proceed with and continue without hindrance the performance of its obligations under this contract with due diligence and expedition in a professional manner except where the contract has been terminated by either party in terms of this contract.

In case of contract with Public Sector Enterprise (PSE) or a Government Department, the following shall be applicable:

In the event of any dispute or difference relating to the interpretation and application of the provisions of the contract, such dispute or difference shall be referred by either party for arbitration to the sole arbitrator in the Department of Public Enterprises to be nominated by the secretary to the Government of India in-charge of the Department of Public Enterprises. The Arbitration and Conciliation Act, 1996 shall not be applicable to arbitration under this clause. The award of the arbitrator shall be binding upon the parties to the dispute, provided, however, any party aggrieved by such award may make further reference for setting aside or revision of the award to the Law Secretary, Department of Legal Affairs, Ministry of Law and

justice, Government of India. Upon such reference the dispute shall be decided by the Law secretary or the special Secretary or Additional secretary when so authorized by the Law secretary, whose decision shall bind the parties hereto finally and conclusively. The parties to the dispute will share equally the cost of arbitration as intimated by the arbitrator.

2. INTEREST CLAUSE:

In order to bring uniformity in all the contracts / agreements entered between BHEL and its contractors / vendors / suppliers / service providers etc., it is hereby advised to incorporate the following clause in all tenders and agreements.

“No interest shall be payable by BHEL on earnest money or security deposit or any money due to the contractor by BHEL.”

11. Governing Law & Jurisdiction:

This agreement shall be construed and interpreted in accordance with the laws of India and shall have exclusive jurisdiction of Sangareddy/Hyderabad courts, Telangana, India.

SIGNATURE

WITNESSES

1

Name:

Address:

2

Name:

Address:

Annexure - III

Proforma for self-certification by Supplier for minimum local content on their letter head for tender value less than Rs 10 Crore

"We _____ (Name of Manufacturer) undertake that we meet the mandatory minimum Local Content (LC) requirement i.e. _____ (to be filled as notified in the policy) for claiming Purchase Preference linked with Local Contents under the Govt. policy against tender no. _____."

Annexure - IV

Proforma for self-certification by Supplier for Compliance to Clause No 20 (B)

I have read the clause regarding restrictions on procurement from a bidder of a country which shares a land border with India and I certify that M/s.... (Name of firm) is **not from such a country/is from such a country** (delete whichever is NOT applicable) and has been duly registered with the Competent authority (delete if NOT applicable) . I hereby certify M/s fulfills all requirements in this regard and is eligible to be considered . (where applicable , valid registration by the competent authority shall be attached)

Sd/-

Authorised Signatory with Stamp