



BHARAT HEAVY ELECTRICALS LIMITED

BAP – Ranipet, 632406

MM – PURCHASE Department (FGD)

Proposed terms for GeM bid as Buyer ATC:

NIT: RFQ (request for quotation) towards “manufacture, inspection, packing, forwarding and dispatch” of Neoprene gaskets

PQR: Technical requirement as below (shall be provided inline with the PQR document as attached in bid)

1. Any previous supply/PO copy shall be submitted along with drawing, data sheet and inspection report for the PPO (previous purchase order)

2. Customer details shall be provided in following format

Cust Name and PO NO	Name	Designation	Mobile	Landline	FAX	email	address	Any other remarks

Delivery Location/Destination: East Gate, Stores-BHELO, BAP-Ranipet 632406, Tamilnadu

Delivery required date: By 24-02-2023 or within 5 months from the date of manufacturing clearance, whichever is later. Bidder to quote the best possible delivery from the date of manufacturing clearance. Abnormal quoted delivery, liable for rejection of offer

Item List: Scope of supply/ BoM

SI	Material code	DESCRIPTION	Qty set	Quoted/ Not quoted
		100% neoprene gaskets as per drg 4-FW-000-01512		
1	RFW217890001	NB 25 as per Drg Item No 01	44	
2	RFW217890002	NB 40 as per Drg Item No 02	8	
3	RFW217890003	NB 50 as per Drg Item No 03	610	
4	RFW217890004	NB 65 as per Drg Item No 04	36	
5	RFW217890005	NB 80 as per Drg Item No 05	258	
6	RFW217890006	NB 100 as per Drg Item No 06	666	
7	RFW217890007	NB 125 as per Drg Item No 07	888	
8	RFW217890008	NB 150 as per Drg Item No 08	393	
9	RFW217890009	NB 200 as per Drg Item No 09	260	
10	RFW217890010	NB 250 as per Drg Item No 10	154	
11	RFW217890011	NB 300 as per Drg Item No 11	220	
12	RFW217890012	NB 350 as per Drg Item No 12	450	
13	RFW217890013	NB 500 as per Drg Item No 17	92	
14	RFW217890014	NB 600 as per Drg Item No 19	15	
15	RFW217890015	NB 800 as per Drg Item No 21	6	
16	RFW217890016	NB 850 as per Drg Item No 22	12	
17	RFW217890017	NB 900 as per Drg Item No 23	12	
18	RFW217890018	NB 1200 as per Drg Item No 25	10	
19	RFW217890019	NB 1300 as per Drg Item No 26	110	
20	RFW217890020	NB 1500 as per Drg Item No 28	8	
21	RFW217890020	NB 1600 as per Drg Item No 29	20	
SI	Material code	DESCRIPTION	Qty set	Quoted/ Not quoted



BHARAT HEAVY ELECTRICALS LIMITED

BAP – Ranipet, 632406

MM – PURCHASE Department (FGD)

Technical requirement

- (a). **Manufacturing: Document Submission**-Drawing, Data sheet and quality plan shall be submitted upon ordering for approval by BHEL. **Manufacturing clearance** will be provided upon approval of drawing with data sheet and QAP. Manufacturing shall be as per attached technical specification in the bid, Approved drawing, Quality plan and Data sheet. **Inspection:** as per CI (b) below stated. **Dispatch Clearance:** Upon submission of inspection reports along with test certificates in original and Packing list dispatch clearance will be provided by BHEL.
- (b). **Inspection:** Inspection (call to be raise by supplier at BHEL COIR portal) before despatch at supplier's works (as per Quality terms and Quality plan) by BHEL/authorised agency (TPI-Third Party Inspection). Inspection includes for painting and packing also, as applicable. All the Test and inspection reports shall be sent to BHEL-Ranipet for review and dispatch clearance. Packing list and weightment details shall be sent for release of GMS by Engineering-BAP. Base on release of GMS, CoC No shall be issued by QC-BHEL. On receipt of CoC, and packing list, request letter from commercial-BAP to be submitted to QC-BHEL for issue of MDCC.
- (c). **Packing requirement:** Packing shall be waterproof in package such that transit damage shall be avoided. The material code with description & Supplier name shall be marked on the packing.
- (d). **Documents:** Accepted IR copy along with relevant test certificates (in original) before despatch to be given to BHEL. This is required for Dispatch clearance.
- (e). **Reverse Auction** shall be conducted, overall package basis L1 (combining all the items) shall be taken for Ordering.
- (f). **Installation, E&C, Trial run and performance test:** NA
- (g). **CEBG / PBG – NA**

Commercial requirement:

1. Quote shall be in INR only, inclusive of GST, as per GeM terms and condition
2. Following documents/formats are attached (signed and stamped copy) in GeM bid. (a) Pre qualification requirement and Drawings, (b) MQP, (c) CQR, (d) Annex Q, (e) GeM bid copy, (f) MII form 1 and 2, (g) UDYAM certificate, if quoted as MSE bidder
3. Non Submission of any of required documents as listed below, attracts for offer rejection.
4. Overall Package wise (considering all the line items in single package) evaluation methodology shall be adopted. All the items shall be ordered to single vendor.
5. MSE firm shall upload the UDYAM portal registration certificate
6. Guarantee / Warrantee: Shall be applicable for 18 months from the date of dispatch as CoC (certificate of Conformance) against the workmanship and manufacturing defects
7. RA is planned through GEM as per GeM rules
8. Payment: 100% payment within 90 days (45 days for MSE and 60 dys for medium cat with UDYAM portal) after receipt and acceptance of material at BHEL along with GST compliance invoice and relevant documents.
9. "False declaration will be in breach of the code of integrity under Rule 175 (i)(h) of the General Finance Rule for which a bidder or its successors can be debarred for up to two years as per Rule 151(iii) of the General Finance Rules along with such other actions as may be permissible under Law"
10. Any offers from such bidders Bidders who are under Hold, banned and suspended by BHEL, shall be rejected at any stage of tender and contract.
11. **For any query:** Kindly provide the "Neoprene gasket-Barh 2" in the subject of mail and send to mail: ckbharti@bhel.in; jecashish@bhel.in, Ph: 9488 58 9287 / 7010 75 1675, You may raise the query through GeM also.



Water Business

Pre-Qualification requirement for Neoprene Gaskets

	00
Dt:	13.08.2022
Rev :	00

The Qualification requirements for NEOPRENE GASKETS are detailed below and Bidders shall meet the same. Offers of bidders who do not meet qualification requirement shall not be considered.

The bidder should have supplied below mentioned NEOPRENE GASKETS to its end User/Customer. Bidder shall provide supporting documents meeting QR such as Data Sheet, Material Test Certificates and Purchase Order Copy etc.

Sl. No.	Description	Size
a.	NEOPRENE GASKETS	≥NB25

General Conditions:

1. Bidder shall furnish necessary documentary evidence as a proof of meeting the qualifying criteria for the review by BHEL. Acceptance of documentary evidence rests with BHEL.
2. Bidder shall fill the details of Customer as given below.
3. Bidders who defaulted, in any of the previous tenders floated by BHEL are not permitted to respond. Such offers, if found later, will not be considered for evaluation.
4. After receipt of offers, during scrutiny, if any vendor found to have been banned by BHEL, then their offer will be summarily rejected at any stage.

Customer details: -

- a. Name :
- b. Designation :
- c. Mobile :
- d. Land line :
- e. Fax :
- f. Email id :
- g. Postal address :

Signature of the Bidder with seal

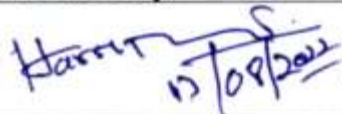
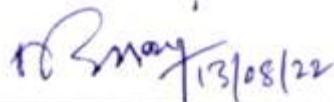
Prepared By:-	Checked By:-	Approved By:-
 13.08.22	 13/08/2022	 13/08/22
Ananta Karmakar (SE/WS)	Harsh Deep (DM/WS)	D Balaraju Naik (Mgr/WS)

CAUTION: The information on this document is the property of BHARAT HEAVY ELECTRICALS LTD. It must not be used directly or indirectly in any way detrimental to the interest of the company.

REV	DATE	ALTERED
		CHECKED

NOTES ALL DIMENSIONS ARE IN MILLIMETRES

- MATERIAL: 100% NEOPRENE RUBBER HAVING SHORE 'A' HARDNESS OF 60±5.
- OPERATING TEMP. OF FLUID SHALL BE 30° C TO 75° C.
- GASKET BOLT HOLES ARE TO BE DRILLED AS PER ASME B16.5 #150, AWWA C207 Cl. D, AWWA C207 Cl. B, PN 6, PN10.

DIMENSION DETAILS

ITEM NO	FLG SIZE	OD (mm)	ID (mm)	PCD (mm)	HOLE DIA (mm)	HOLE (Nos)	THK (mm)	DRILLING STD
1	NB25	110	34.5	80	16	4	4	ASME B16.5 CL 150
2	NB40	125	50	98.4	16	4	4	ASME B16.5 CL 150
3	NB50	150	62	121	19	4	4	ASME B16.5 CL 150
4	NB65	180	74.6	140	19	4	4	ASME B16.5 CL 150
5	NB80	190	90.7	153	19	4	4	ASME B16.5 CL 150
6	NB100	225	116	190.5	19	8	4	AWAA C207 Class D
7	NB125	250	144	215.9	22	8	4	AWAA C207 Class D
8	NB150	280	171	241.3	22	8	4	AWAA C207 Class D
9	NB200	340	221.5	298.5	22	8	4	AWAA C207 Class D
10	NB250	405	276	362	26	12	4	AWAA C207 Class D
11	NB300	480	327	431.8	26	12	4	AWAA C207 Class D
12	NB350	530	360	476.3	29	12	4	AWAA C207 Class D
13	NB400	595	411	539.8	29	16	4	AWAA C207 Class D
14	NB400	540	411	495	22	16	4	PN6
15	NB400	565	411	515	26	16	4	PN10
16	NB450	635	462	578	32	16	4	AWAA C207 Class D
17	NB500	695	513	635	32	20	4	AWAA C207 Class D
18	NB550	750	564	692	35	20	4	AWAA C207 Class B
19	NB600	810	615	750	35	20	4	AWAA C207 Class B
20	NB700	925	716	864	35	28	4	AWAA C207 Class B
21	NB800	1060	818	978	41	28	4	AWAA C207 Class B
22	NB850	1110	868	1028.7	41	32	4	AWAA C207 Class B
23	NB900	1170	919	1086	41	32	4	AWAA C207 Class B
24	NB1000	1290	1021	1200	41	36	4	AWAA C207 Class B
25	NB1200	1510	1224	1422	41	44	4	AWAA C207 Class B
26	NB1300	1625	1326	1537	48	44	4	AWAA C207 Class B
27	NB1400	1740	1428	1651	48	44	4	AWAA C207 Class B
28	NB1500	1850	1528	1759	48	52	4	AWAA C207 Class B
29	NB1600	1965	1630	1867	48	52	4	AWAA C207 Class B
30	NB1700	2080	1732	1981	48	60	4	AWAA C207 Class B
31	NB1800	2195	1834	2096	48	60	4	AWAA C207 Class B
32	NB1900	2310	1935	2210	54	60	4	AWAA C207 Class B
33	NB2000	2425	2037	2318	54	64	4	AWAA C207 Class B

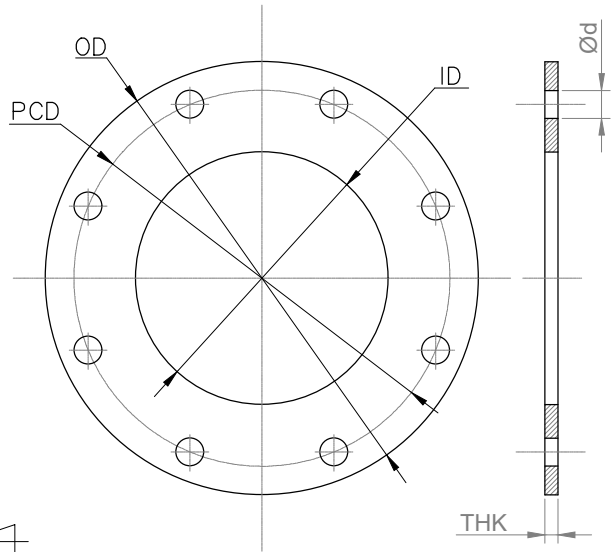

RUBBER GASKET

FOR TENDER PURPOSE ONLY

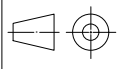
 BHARAT HEAVY ELECTRICALS LTD., UNIT: BOILER AUXILIARIES PLANT. RANIPET - 632 406.	DRN	S KAMESH	SIGN	---	DATE	26.04.2022	NO. OF VAR	
	CHD	DHEERAJ KUMAR	SIGN	---	DATE	27.04.2022		
	APPD	P KONDAPANAIIDU	SIGN	---	DATE	27.04.2022		
DEPT WS	GRADE OF UNTOL. DIM		SCALE	WEIGHT (KG).	REF. TO ASSY./OLD DRG.		ITEM NO.	NO. OF ITEMS
CODE 9776	PR: QA: 500		NTS	----				
TITLE			CARD CODE	DRAWING NO.			REV	
NEOPRENE RUBBER GASKETS			U 01	4-FW-000-01512			00	

Quality Assurance (Mechanical)
CONTRACT QUALITY REQUIREMENT (CQR)

MOUDA: NEO GASKET: 546
Dt. 20-08-2022

SL No	Indent No	PGMA	Item Description	Project
01	RFW21789	FW870	NEOPRENE RUBBBER GASKETS	MOUDA (2X500 MW)
QP NO. GASKET: 749/01, DT: 11.12.2020			Drawing No: 4-FW-000-01512	

Following are Quality recommendation:

1. All the items shall be inspected at Manufacturer works as per BHEL SQP/BHEL Drawing/Approved datasheet and Technical Specification.
2. Physical Inspection shall be done by BHEL/BHEL AIA at Manufacturer works.
3. BHEL Approved Source is acceptable.
4. Arrange Vendor acceptance for BHEL SQP (QP NO. GASKET: 749/01, DT: 11.12.2020). Any clarification on this SQP shall be discussed and settled with relevant/Standard/ technical discussion before PO placement.
5. Packing of items shall be as per BHEL Engg Approved Packing Drawing/Technical Specifications.
6. BHEL Authorized representatives shall have the right to witness the necessary inspection and testing of goods mentioned in the PO. The supplier shall inform BHEL in advance about the readiness of the goods for inspection and testing. Inspection / Inspection wavier / approval by BHEL does not absolve Supplier's responsibility for conformity of the specification as per the terms of PO. Material Test Certificates shall be submitted to BHEL.
7. Annexure 'Q' shall be part of enquiry File and shall be filled by Supplier with their duly sign and seal.
8. **General Inspection Notes:**
 - a. Latest version of standards & Specification shall be applied.
 - b. Materials shall be procured in compliance to Functional Technical specification.
 - c. Gauges and measuring instruments with valid calibration only shall be used.
 - d. Inspection / Inspection wavier / approval by BHEL does not absolve Supplier's responsibility for conformity of the specification as per the terms of PO.
 - e. BHEL /BHEL Authorized representatives shall have the right to witness the necessary inspection and testing of goods mentioned in the PO.
 - f. In case of Vendor Drawing & Datasheet, it needs approval by BHEL Engineering.
 - g. This QP shall be read along with relevant PO, BHEL Specification / Approved Drawing/Datasheet.

This is for your information and further necessary action at your end please.

Sd\ - Rakesh Kr Madhu
Dy/Mgr-QA



Sd\ - K Renjith
Mgr/QA

Annexure to Enquiry no:		Date
Sl.No	BHEL / Customer Requirement	##Specific confirmations by the manufacture
1	Quality Plan Requirement:	
	(i) MQP (Manuafcutering Quality Plan) shall be submitted in attached format for BHEL/Customer review & approval. Typical MQP is attached for indicative purposes for guidance & use.	
	(ii) MQP shall invariably cover w.r.t Inward inspection including on Raw materail Procurement, In process and Final inspection in elaborated way/details.	
	(iii) Bidder shall also to give specific confirmation that on need basis, their competent officials shall visit to BHEL/customer for finalization of Quality plan including test procedure/methodology during preaward / post award approval / detailed engineering in the event of an order.	
	(iv) No deviation on BHEL/Customer approved MQP is acceptable.	
	(v) Bidder shall agree to submit all cross referred documents other than codes/standrads to BHEL/Customer/Consultant.	
	Important Notes shall be included in MQP : (a) Latest revision of Standard s & Specification shall apply. Only International Standards are applicable. Indian & Chinese Standards are not applicable (b) Materials shall be procured in compliance to Functional Technical Specification. (c) Inspection shall be in compliance with Approved Quality Control Procedure for the Product. (d) NDT shall be carried out by Qualified Personnel with compliance to Approved NDT Procedures and Acceptance Norms, as per ASME Section V. (e) Gauges and measuring Instruments, with valid calibration only shall be used. (f) Cleaning and Painting of products shall be carried out as per Approved Painting Schedule. (g) Finished Products shall be packed to comply with Approved Packing Schedule. (h) Welding shall be carried out by Qualified Personnel with compliance to Approved NDT Procedures and Acceptance Norms, as per ASME Section V.	
2	Domestic / Inland Inspection will be carried out by BHEL/BHEL apointed Third Party Inspection Agency (TPIA) / Customer/Customer Apointed Inspection Agency/Consulatnat. This is applicable for all Stage inspection and Final Inspection identified as "W" - Witness or "CHP" - Customer Hold Point as per customer approved Quality Plan/ Technical specification / Approved Drawing/ Approved Data sheet / Scheme / PID / PFD / SLD (Process Instrumentaion Diagram / Process Flow Diagram / Single Line Diagram) etc (As applicable). "The inspection charges at actuals incurred by BHEL will be loaded to compare with foreign suppliers".	
3	Inspection Agency for Foreign Bidders and also for Indian Bidder but importing from Forgign Sources: (1) Any one of the fllowing Third Party Inspection Agency (TPIA) shall be appointed by the bidder and same shall be furnished by the bidder in techno commercial bid itself. (2) The details of TPIA with contact details like Name of the official, Phone no, Email id shall also to be submitted during pre/post award. However cost for such inspection agency shall be borne by the bidder only. Inspection charges for such inspection agency shall be indicated separately so that if BHEL/Customer is undertaking the inspection by on their own , then these charges non claimable by the bidder. List of TPIA 1.M/s Bureau Veritas 2.M/s TUV-Nord 3.M/s TUV-SUD 4.M/s TUV Rheinland 5.M/s Lloyds Register 6.M/s SGS 7.M/s Germanischer Lloyds 8.M/s QUEST 9.M/s Certification Engineers International 10.M/s Intertek 11.M/s IR Class Systems and Solutions 12.M/s DNV 13. M/s Fichtner 14. M/s ABS Inspection Services	
4	Stage Inspection during manufacturing Process : Stage Inspection during manufacturing shall be carried out as per approved quality plan and all necessary documents shall be provided for review,verification and clearanace for further processing. This inspection call shall be given well in advance (atleast 2 weeks before) to TPI/Bidder's own inspection agency to avoid delay in the manufacturing processes.	

Sl.No	BHEL / Customer Requirement	##Specific confirmations by the manufacture
5	Inspection before despatch for domestic supplier : Inspection before despatch at supplier's works shall be carried out by BHEL/BHEL appointed Inspection agency. Inspection shall be done as per approved Quality plan/ Technical specification/ Approved Drawing/ Approved Data sheet .	
6	Inspection at Foreign Source/Supplier: (a) As in sl no: 3. shall be ensured without fail (b) No materail / items shall be despatched without getting the written communication from BHEL / Customer inspection carried out by BHEL/BHEL apointed Third Party Inspection Agency (TPIA) / Customer/Customer Apointed Inspection Agency/Consulatnat. This is applicable for all Stage inspection and Final Inspection identified as "W" - Witness or "CHP" - Customer Hold Point as per customer approved Quality Plan/ Technical specification / Approved Drawing/ Approved Data sheet / Scheme / PID / PFD / SLD (Process Instrumentaion Diagram / Process Flow Diagram / Single Line Diagram) etc (As applicable). Inspection before despatch for Foreign supplier : Inspection before despatch at supplier's works shall be carried out by bidder appointed inspection agencies having international presence at vendors and or vendor's sub vendor works. Inspection shall be done as per approved Quality plan/ Technical specification/ Approved Drawing/ Approved Data sheet by TPIA mentioned in Sl no: 03 at supplier's cost.	
7	Painting shall be done strictly as per BHEL/Customer approved painting schedule / scheme only. Paint Thickness / Paint shade shall be ensured as per BHEL / Customer approved painting schedule / specification / data sheet etc. No deviation is acceptable unless otherwise accepted by BHEL/Customer in writing. Any conflict if any among BHEL / Customer approved painting schedule / Spec / data sheet etc shall be brought to the notice to BHEL well in advavnce before proceding including the BOI being procured for assy / skid like motors etc	
8	Specific conformation for document package in the event of an order (2 Hard copies & soft copy in PDF file) is to be given containing the following with proper linkages (i) Index Sheet (ii) MQP/RQP/Endorsemmnt Sheet (As applicable) (iii) TCs identified by BHEL/ Customer for record for "CHP" / "W" and Verification portion ("V") as given in approved QP. (iv) Final inspection report + TC including Chemical + Mechnaical + HT + NDT etc (v) Third party Inspection report + TC (vi) Customer CHP/ MDCC (vii) Type test / Performance Test reports conducted (viii) Type test / Performance Test approval/ clearance obtained from BHEL/Customer (ix) BOM with As Build Drgs with actual make / rating used with BHEL/customer approved drawings.	
9	Packing / Seaworthy Packing shall be as per BHEL Packing schedule / approved drg / sketch. This shall be ensured to take care tarnsit / handling / transhipment in Road / Sea / Air. Photographs are to be submitted for BHEL review before despatching the material as per contract conditions.	
10	Outsourcing of test facilities: Bidder shall ensure all the testing facilities in house. However If any of the test facilities are not available with successful bidder, then bidder shall ensure the same at NABL accreadted third party lab / Govt / Govt Lab for major testing such as NDT, Electrical & Mechanical testing.	
11	Important Note: No deviation on the above requirement 01 to 10 is acceptable w.r.t Quality Requirement and those offers not meeting these specific customer requirement is liable for rejection and hence the bidder shall submit all the required documentary evidances in the offer itself.	
12	## Necessorily to be filled up by the bidder at the time of offer itself otherwise the offer may not be considered w.r.t Quality Requirement being customer specific requirement.	

 रनिपेट Ranipet	MANUFACTURER'S NAME & ADDRESS BHEL/ BHEL APPROVED SOURCE		STANDARD QUALITY PLAN ITEM: NEOPRENE GASKETS				QP. NO.: GASKET :749 Rev No. :01 Date: 11.12.2020 Page 1 of 2		PROJECT: AS PER PO.				
	SL NO	COMPONENT & OPERATION	CHARACTERISTICS	CLASS OF CHECK	TYPE OF CHECK	QUANTUM OF CHECK		REFERENCE DOCUMENTS	ACCEPTANCE NORMS	FORMAT OF RECORD		Agency	
1	2	3	4	5	M	B/C	7	8	9	D	**10	11	

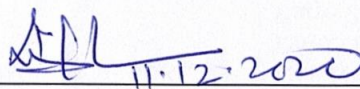
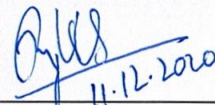
1.0 RAW MATERIALS														
1.1	Polymer Identification on Neoprene	Determination of Rubber Polymer	Major	Visual & Measurement	1 Sample / Batch	1 Sample / Batch	ASTM D297:2015 /Latest	ASTM D297:2015 /Latest	TC	√	P	V	-	
1.2	Neoprene Rubber after compounding	Tensile Strength and Elongation	Major	Measurement	1 Sample / Batch		Relevant standard.	Spec/Datasheet/ Relevant std.	TC	√	P	V	-	
2.0 INPROCESS CONTROL														
2.1	Building of Re-Joints & Vulcanizing	Dimension of Die Moulding	Major	Measurement	100%	100%	Relevant standard.	Approved Spec. / Relevant Std	Report	√	P	V	-	
		Curing time & Temperature	Major	Perusal of Curing Chart	100%	100%	Relevant standard.	Manufacturer Plant Procedure	Curing Chart	-	P	V	-	
2.2	Shore Hardness	Hardness	Major	Measurement	1 Sample / Batch		Relevant standard.	60+/-5 Shore A	TC	√	P	V	-	Refer Drg for Details.
3.0 FINAL INSPECTION														
3.1	Rubber Gasket	Dimension, Workmanship, Finish & Appearance	Major	Visual & Measurement	100%	100%	D1330/ Material Specification	Drawing/ Material Specification	Report	√	P	W	-	
3.2	Identification, Packing & Preservations	Visual	Major	Visual	100%	100%	P.O. / Material Specification	P.O. / Material Specification	COC	-	P	V	-	

M – Manufacturer / Subcontractor, B - BHEL /BHEL Authorized Inspection Agency, C – Customer/ Customer Authorized Inspection Agency, P - perform, V - Verification of reports W - Witness, TC - Test certificate "D" – Record, identified with tick (√) shall be essentially included by Supplier in QA documentation. COC- Certificate of Conformance	Prepared by	Reviewed by	Approved by
	 11.12.2020	 11.12.2020	For 
	Rakesh Kr Madhu (Dy Manager/ QA)	K Renjith (Manager/ QA)	R Arunachalam(Dy.GM/ QA)

 बी एच ई एल BHEL Ranipet		MANUFACTURER'S NAME & ADDRESS BHEL/ BHEL APPROVED SOURCE		STANDARD QUALITY PLAN				PROJECT: AS PER PO.						
				ITEM: NEOPRENE GASKETS		QP. NO.: GASKET :749 Rev No. :01 Date: 11.12.2020 Page 2 of 2								
SL NO	COMPONENT & OPERATION	CHARACTERISTICS	CLASS OF CHECK	TYPE OF CHECK	QUANTUM OF CHECK		REFERENCE DOCUMENTS	ACCEPTANCE NORMS	FORMAT OF RECORD		Agency			REMARKS
					M	B/C			9	D	M	B	C	
1	2	3	4	5	M	B/C	7	8	9	D	**10			11



Note:

1. Materials shall be procured in compliance to Functional Technical Specification/Drawing.
2. Gauges and measuring Instruments, with valid calibration only shall be used
3. Finished Products shall be packed to comply with approved Packing Schedule..
4. Curing Chart to be supplied with Manufacturers test certificate (MTC) only.
5. All the inspection report as per P.O. shall be submitted to BHEL for Review and record purpose.

**** This QP Shall be read along with relevant P.O. and BHEL Drawing/Specification.**

Record of revision

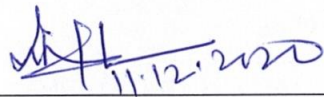
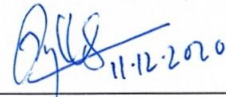
Rev no	Date	description
00	14.03.2020	Original Issue
01	11.12.2020	Reviewed and totally revised

M – Manufacturer / Subcontractor, B - BHEL /BHEL Authorized Inspection Agency, C – Customer/ Customer Authorized Inspection Agency, P - perform, V - Verification of reports W - Witness, TC - Test certificate "D" – Record, identified with tick (√) shall be essentially included by Supplier in QA documentation. COC- Certificate of Conformance	Prepared by	Reviewed by	Approved by
	 11.12.2020	 11.12.2020	
	Rakesh Kr Madhu (Dy Manager/ QA)	K Renjith (Manager/ QA)	R Arunachalam(Dy.GM/ QA)

Bharat Heavy Electricals Limited

Ranipet-632406, India.

Quality Assurance(Mech)

To,

Shri. V Jothimanickam, SM/Purchase

Kind Attn: Shri Chandan Kumar Bharti, SEr/Purchase

BAP: FGD: GASKETS: 129

Dt. 12-12-2020

Item Name	Indent No	Indent Dt.	PGMA	Technical Specification/Drawing No
NEOPRENE Gaskets	RFW01069, Rev:00	27.11.2020	FW752	4-FW-752-01140, 4-FW-752-01144
PTFE Gaskets	RFW01090, Rev:00	27.11.2020	FW752	4-FW-752-01141

Project: MAITREE (2X660 MW.), Engg Transmittal No: Neoprene Gaskets: FGD: 0001,

DT: 27.11.2020 and PTFE Gaskets: FGD: 0001, DT: 27.11.2020

Following are Quality recommendation:

1. BHEL Approved source is acceptable.
2. All the items shall be inspected at Manufacturer works as per BHEL approved QP/Approved Drawing/Approved datasheet and Technical Specification.
3. Physical Inspection shall be done by BHEL/BHEL AIA.
4. Arrange vendor acceptance on attached Quality plan GASKET: 749/01, DT: 11.12.2020 from vendor with duly sign and stamp for Neoprene Gaskets. For PTFE Gaskets arrange Vendor QP in similar pattern(same format with check for raw materials, in process and final inspection) including details of Manufacturing process/Catalogue.
5. Already other customer approved like NTPC, State electricity Board, Water treatment/ FGD Plant etc. latest MQP for similar application if available specific to Vendor may be shared for reference purpose.
6. Packing of items shall be as per BHEL Engg Approved Packing Drawing/Packing Specifications.
7. BHEL Authorized representatives shall have the right to witness the necessary inspection and testing of goods mentioned in the PO. The supplier shall inform BHEL in advance about the readiness of the goods for inspection and testing. Inspection / Inspection wavier / approval by BHEL does not absolve Supplier's responsibility for conformity of the specification as per the terms of PO. Material Test Certificates shall be submitted to BHEL.
8. Annexure 'Q' shall be part of enquiry File and shall be filled by Supplier with their duly sign and seal. Supplier should be manufacturer not a trader/Agent. *(If the OEM/Principal engaging the services of an agent to participate on their behalf, vendor will be acceptable with respect to Quality requirement provided acceptance on Point No 2, 3, 7 and 9 shall be accepted to supplier)*
9. **Vendor Quality Plan shall contain following Inspection Notes:**
 - a. Latest version of standards & Specification shall be applied.
 - b. Materials shall be procured in compliance to Functional Technical specification.
 - c. Gauges and measuring instruments with valid calibration only shall be used.
 - d. Inspection / Inspection wavier / approval by BHEL does not absolve Supplier's responsibility for conformity of the specification as per the terms of PO.
 - e. BHEL /BHEL Authorized representatives shall have the right to witness the necessary inspection and testing of goods mentioned in the PO.
 - f. In case of Vendor Drawing & Datasheet, it needs approval by BHEL Engineering.
 - g. This QP shall be read along with relevant PO, BHEL Specification / Approved Drawing/ Datasheet.



Prepared by.
Rakesh Kr Madhu (Dy.Mgr/QA)



Reviewed & Approved by.
K Renjith(Mgr/QA)

Annexure Q - All the conditions shall be complied

Sl.No	BHEL / Customer Requirements
1	Quality Plan Requirement:
	(i) MQP (Manufacturing Quality Plan) shall be submitted in attached format for BHEL/Customer review & approval. Typical MQP is attached for indicative purposes for guidance & use.
	(ii) MQP shall invariably cover w.r.t Inward inspection including on Raw material Procurement, In process and Final inspection in elaborated way/details.
	(iii) Bidder shall also to give specific confirmation that on need basis, their competent officials shall visit to BHEL/customer for finalization of Quality plan including test procedure/methodology during preaward / post award approval / detailed engineering in the event of an order.
	(iv) No deviation on BHEL/Customer approved MQP is acceptable.
	(v) Bidder shall agree to submit all cross referred documents other than codes/standards to BHEL/Customer/Consultant.
2	Important Notes shall be included in MQP :
	(a) Latest revision of Standards & Specification shall apply. Only International Standards are applicable. Indian & Chinese Standards are not applicable; (b) Materials shall be procured in compliance to Functional Technical Specification.; (c) Inspection shall be in compliance with Approved Quality Control Procedure for the Product.
	(d) NDT shall be carried out by Qualified Personnel with compliance to Approved NDT Procedures and Acceptance Norms, as per ASME Section V.; (e) Gauges and measuring Instruments, with valid calibration only shall be used.
	(f) Cleaning and Painting of products shall be carried out as per Approved Painting Schedule.; (g) Finished Products shall be packed to comply with Approved Packing Schedule.; (h) Welding shall be carried out by Qualified Personnel with compliance to Approved NDT Procedures and Acceptance Norms, as per ASME Section V.
	Domestic / Inland Inspection will be carried out by BHEL/BHEL appointed Third Party Inspection Agency (TPIA) / Customer/Customer Appointed Inspection Agency/Consultant. This is applicable for all Stage inspection and Final Inspection identified as "W" - Witness or "CHP" - Customer Hold Point as per customer approved Quality Plan/ Technical specification / Approved Drawing/ Approved Data sheet / Scheme / PID / PFD / SLD (Process Instrumentation Diagram / Process Flow Diagram / Single Line Diagram) etc (As applicable).
	Inspection Agency for Foreign Bidders and also for Indian Bidder but importing from Foreign Sources: (1) Any one of the following Third Party Inspection Agency (TPIA) shall be appointed by the bidder and same shall be furnished by the bidder in techno commercial bid itself. (2) The details of TPIA with contact details like Name of the official, Phone no, Email id shall also to be submitted during pre/post award. However cost for such inspection agency shall be borne by the bidder only. Inspection charges for such inspection agency shall be indicated separately so that if BHEL/Customer is undertaking the inspection by on their own, then these charges non claimable by the bidder. List of TPIA 1.M/s Bureau Veritas, 2.M/s TUV-Nord, 3.M/s TUV-SUD, 4.M/s TUV Rheinland, 5.M/s Lloyds Register, 6.M/s SGS, 7.M/s Germanischer Lloyd, 8.M/s QUEST, 9.M/s Certification Engineers International, 10.M/s Intertek, 11.M/s IR Class Systems and Solutions, 12.M/s DNV, 13. M/s Fichtner, 14. M/s ABS Inspection Services
3	Stage Inspection during manufacturing Process : Stage Inspection during manufacturing shall be carried out as per approved quality plan and all necessary documents shall be provided for review, verification and clearance for further processing. This inspection call shall be given well in advance (atleast 2 weeks before) to TPI/Bidder's own inspection agency to avoid delay in the manufacturing processes.
4	Inspection before despatch for domestic supplier : Inspection before despatch at supplier's works shall be carried out by BHEL/BHEL appointed Inspection agency. Inspection shall be done as per approved Quality plan/ Technical specification/ Approved Drawing/ Approved Data sheet .
5	Painting shall be done strictly as per BHEL/Customer approved painting schedule / scheme only. Paint Thickness / Paint shade shall be ensured as per BHEL / Customer approved painting schedule / specification / data sheet etc. No deviation is acceptable unless otherwise accepted by BHEL/Customer in writing. Any conflict if any among BHEL / Customer approved painting schedule / Spec / data sheet etc shall be brought to the notice to BHEL well in advance before proceeding including the BOI being procured for assy / skid like motors etc
6	Specific conformation for document package in the event of an order (2 Hard copies & soft copy in PDF file) is to be given containing the following with proper linkages ----- (i) Index Sheet, (ii) MQP/RQP/Endorsement Sheet (As applicable) (iii) TCs identified by BHEL/ Customer for record for "CHP" / "W" and Verification portion ("V") as given in approved QP. (iv) Final inspection report + TC including Chemical + Mechanical + HT + NDT etc (v) Third party Inspection report + TC (vi) Customer CHP/ MDCC (vii) Type test / Performance Test reports conducted (viii) Type test / Performance Test approval/ clearance obtained from BHEL/Customer (ix) BOM with As Build Drgs with actual make / rating used with BHEL/customer approved drawings.
7	Outsourcing of test facilities: Bidder shall ensure all the testing facilities in house. However If any of the test facilities are not available with successful bidder, then bidder shall ensure the same at NABL accredited third party lab / Govt / Govt Lab for major testing such as NDT, Electrical & Mechanical testing.
8	Important Note: No deviation on the above requirement 01 to 10 is acceptable w.r.t Quality Requirement and those offers not meeting these specific customer requirement is liable for rejection and hence the bidder shall submit all the required documentary evidences in the offer itself.
9	## Necessarily to be filled up by the bidder at the time of offer itself otherwise the offer may not be considered w.r.t Quality Requirement being customer specific requirement.
10	

*(To be submitted In the company letter head by supplier)

Form - 1

Subject: Public Procurement (Preference to Make In india)

References:

- 1.P-45021/2/2017-B.E-II dated. 15th June-2017,
- 2.P-45021/2/2017-PP(BE-II) dated. 28th May-2018 ,
- 3.P-45021/2/2017-PP(BE-II) dated. 29th May-2019.
- 4.P-45021/2/2017-PP(BE-II) dated. 4th June-2020

We hereby declare with reference to above subject and references that M/s -----(Tick whichever is applicable as below)

"Class-I local supplier" meeting the requirement of minimum local content equal to 50%(fifty percent) or more defined in the above government notification for the goods and services (or)

"Class-II local Supplier" meeting the requirement of local content 20% to less than 50%(fifty percent) defined in the above government notification for the goods and services

Please mention the details against the following:

Enquiry no:----- dated. -----

Type of Supplier (Class-I/Class-II)

Product:-----

Project:.....

Details of location at which local value addition will be made is as follows:

We also understand that the false declarations will be in breach of the code of Integrity under rule 175(1)(i)(h) of the General financial rules for which a bidder or its successors can be debarred for up to two years as per Rule 151(iii) of the General Financial Rules along with such other actions as may be permissible under law.

Authorized Signature M/s _____

(Signature and seal)

Place:.....

Date:.....

From.

M/s _____

Address: _____

Note: For offer value INR 10 crores or more, shall be vetted/endorsed by statutory auditor or cost auditor, for the declared local content.

***(To be submitted In the company letter head by supplier)**

Form – 2

I/we are bidder from _____ (Address with country). We do not belong to any of the below category mentioned.

1. Any of entity/office/workshop of your organisation/incorporation, established in a country sharing land border with India, If yes, provide the full address of all such locations.
2. Any of subsidiary of your organisation/incorporation, established in a country sharing land border with India, If yes, provide the full address of all such locations.
3. Any of entity/office/workshop of your organisation/incorporation, controlled in a country sharing land border with India, If yes, provide the full address of all such locations.
4. Any of entity whose beneficial owner is situated in a country sharing land border with India, If yes, provide the full name, address of all such locations.
5. Any Indian Agent available, If so, Provide details of address and contacts.
6. Any employee/directors who is/are citizen of country sharing land border with India, If yes, provide the full name, employee code and address of all such locations.
7. Any of consortium/joint venture of your organisation/incorporation, established in a country sharing land border with India, If yes, provide the full address of all such locations.

Meaning of beneficial owner

- 1) In case of a company or limited liability partnership, beneficial owner is the natural person, who, whether acting alone or together, or through one or more judicial person, has a controlling ownership interest or who exercises control through other means.

Explanation

- a) Controlling ownership interest means ownership of or entitlement to more than twenty-five percent of shares or capital or profits of the company.
 - b) “control” shall include the right to appoint majority of the directors or to control the management rights or shareholder’s agreement or voting agreement.
- 2) In case or a partnership firm the beneficial owner is the natural person (s) who whether acting alone or together or through one or more judicial person, has ownership of the entitlement to more than fifteen percent of capital or profits of the partnership.
 - 3) In case of an unincorporated association or body of individuals, the beneficial owner is the natural person(s), who, whether acting alone or together or through one or more judicial person, has ownership of the entitlement to more than fifteen percent of the property or capital or [profits of such association or body of individual.
 - 4) Where no natural person is identified under (1) or (2) or (3) above, the beneficial owner is the relevant natural person who holds the position of senior managing official.
 - 5) In case of a trust, the identification of beneficial owner (s) shall include identification of the author of the trust, the trustee, the beneficiaries with fifteen percent or more interest in the trust and any other natural person exercising ultimate effective control over the trust and any other

***(To be submitted In the company letter head by supplier)**

natural person exercising the ultimate effective control over the trust through a chain of control of ownership.

- 6) An agent is a person employed to do any act for another, or to represent another in dealing with third person.

We have read the clause regarding restriction on procurement from a bidder of a country which shares a land border with India, we hereby declare that we do not belongs to any such country and are eligible to be considered.

In case, any of information is found to be false, even after bid acceptance, immediate termination may happen and action will be taken as per law.

Format is being filled without altering any of the clause mentioned in the given format**

Dated: _____

Authorised Sign and stamp_____