

ANNEXURE-I : BILL OF QUANTITY

MAIN SUPPLY : CONTROL VALVES COMPLETE WITH POSITIONER AND ALL ACCESSORIES MOUNTED, TUBED AND TERMINATED ON JB

SI. NO.	TAG NO	DESCRIPTION	QTY. FOR 1 UNIT	UOM
[A]	FDV-14	LOW LOAD FEED CONTROL VALVE	1	NO.
[B]	1/4 " SS TUBING (25 METER FOR EACH TAG)		25	METER
[C]	SS FITTINGS- FOR EACH TAG			
1	SS FITTINGS for connection to Air Filter Regulator- FOR EACH TAG		1	LOT
2	SS FITTINGS for connection to Air Lock Relay- FOR EACH TAG		1	LOT
3	SS FITTINGS for connection to IA Header Isolation Valve - FOR EACH TAG		1	LOT
4	SS EQUAL TEE - FOR EACH TAG		1	LOT
5	SS 1/2 " NPT(M) X 1/4 " OD TUBE CONNECTOR- FOR EACH TAG		1	LOT
[D]	VALVE DIAGNOSTIC AND CONFIGURATION SOFTWARE (FOR ALL TAGS)		1	LOT
[E]	CV TEST CHARGE		1	NO.

LIST OF COMMISSIONING SPARES :

SI. NO.	ITEM DESCRIPTION	QUANTITY PER UNIT
1	Gaskets	One(1) set with each control valve tag
2	Gland Packing	One(1) set with each control valve tag

LIST OF MANDATORY SPARES :

SI. NO.	ITEM DESCRIPTION	QUANTITY PER UNIT
1	Bonnet Seal	2Set (one set means complete replacement required for one Valve)
2	Gland Packing	3Set (one set means complete replacement required for one Valve)
3	Plug, Seat, Cage, Stem etc.	1Set (one set means complete replacement required for one Valve)
4	Retainer Ring, Seal Ring etc.	1Set (one set means complete replacement required for one Valve)
5	Actuator Seal Kit for Pneumatic Cylinder	2Nos.
6	Smart Positioner of the Valve	1No.
7	Position Feedback Transmitter (applicable if it is not integral with the Smart Positioner)	1No.

NOTE :

1. Wherever quantity has been specified as percentage (%), the quantity of mandatory spares to be provided by contractor shall be the specified percentage (%)of the total population of the plant. In case the quantity so calculated happens to be a fraction, the same shall be rounded off to next higher whole number.

2. Wherever the quantities have been indicated for each type, size, thickness, material, radius, range etc., these shall cover all the items supplied and installed and the breakup for these shall be furnished in the bid. In case spares indicated in the list are not applicable to the particular design offered by the bidder, the bidder should offer spares applicable to offered design with quantities generally in line with the approach followed in the above list.

SAGARDIGHI UNIT 5 - Annexure A :- Delivery Schedule of CONTROL VALVE (FEED CONTROL VALVE)

Sl. No.	Package Code	Package name	Deptt.	BHEL Drawing No	Drawing Title	Primary/Secondary	BHEL Inputs	Drg Sch for Vendors	Standard Delivery Terms for Supply Portion
1	145-04000-A	CONTROL VALVE	C&I	PE-V0-XXX-145-1802	DATA SHEET, CALCULATION, BOQ/BOM, GA DRAWING, EDGE Preparation details & HOOK UP / INSTALLATION DRAWING for Control Valves	Primary		R-0 within 14 days from PO & subsequent revisions incorporating all the BHEL comments within 10 days of comments received from BHEL.	Main Supply :- Within Six (06) months from date of CAT-1 approval of Primary drawing/documents or BHEL manufacturing clearance whichever is later, subjected to drawing/document submission/re-submission schedule as stipulated, in case of any delay in submission/re-submission of Primary drawing/documents, then same shall be reduced from the given delivery period. Mandatory Spares :- Mandatory Spares shall be supplied within Six (06) months from BHEL Manufacturing Clearance. Separate manufacturing clearance shall be accorded for mandatory spares.
				PE-V0-XXX-145-1803	QAP for Control Valves	Primary			
				PE-V0-XXX-145-1806	O&M MANUAL for Control Valves	Secondary		Within 30 days of issuance of MDCC	

- Notes :**
- The end period specified is for completion of the deliveries. Deliveries to start progressively so as to meet the completion schedule.
 - The delivery conditions specified are for contractual LD purposes, however BHEL may ask for early deliveries without any compensation thereof.
 - Non-applicable drawings shall be decided during bid evaluation of the package.
 - Wherever schedule of drawings/documents submission / re-submission is stipulated in the Technical Specifications, same shall be superseded by delivery specified in NIT.
 - Vendor to start manufacturing activities only after obtaining specific manufacturing clearance from BHEL Purchase group.

ANNEXURE R :- RISK & COST PURCHASE

DEFAULT/ BREACH OF CONTRACT, INSOLVENCY AND RISK PURCHASE

In case of delays (beyond the maximum late delivery period as per LD clause) in supplies, or if there be defective supplies or non-fulfilment of any other terms and conditions of the Contract as enumerated subsequently in this clause, then, without prejudice to its right to recover any expenses, losses or damages to which the Buyer may be put to incur or sustain by reason of the Seller/Contractor's default or breach of Order/Contract or to suspend business dealings with the Seller/Contractor in terms of the Buyers' Guidelines for Suspension of Business Dealings as applicable from time to time, the Buyer shall also be entitled to cancel the Order/ Contract either in whole or portion thereof without compensation to Seller. On the occurrence of any of the acts/omissions mentioned below, the Buyer may if it so desires, procure upon such terms and in such manner as deemed appropriate, plant/ equipment/ stores not so delivered or others of similar description where plant/ equipment/ stores exactly complying with particulars are not, in the opinion of the Buyer (which shall be final), readily procurable, at the risk and cost of the Seller.

The Seller shall be liable to the Buyer for any excess costs incurred thereof and the Seller shall continue the performance of the Order/Contract to the extent not cancelled under the provisions of this clause. The Seller shall on no account be entitled to any gain on such repurchases. If the Bidder does not agree to this Risk Purchase clause, BHEL reserves the right to reject the bid/offer of the Bidder.

The order/contract may be cancelled in whole or part thereof and Risk & Cost Clause in line with terms and conditions of PO/Contract may be invoked by the Buyer in any of the following cases:

- i. If the Seller/Contractor fails to deliver the goods or materials or any installment thereof within the period(s) fixed for such delivery or the Seller's poor progress of the supply/services vis-à-vis delivery/execution timeline as stipulated in the contract, backlog attributable to the Seller including unexecuted portion of supply does not appear to be executable within balance period available;
- ii. delivers goods or materials not of the contracted quality and failing to adhere to the contract specifications/execution methodology;
- iii. withdrawal from or repudiation/abandonment of the supply/services by the Seller before completion as per contract or if the Seller refuses or is unable to supply goods or materials covered by the order/Contract either in whole or in part or otherwise fails to perform the Order/Contract.

- iv. Non supply by the Seller within scheduled completion/delivery period as per contract or as extended from time to time for reasons attributable to the Seller;
- v. Termination of Contract on account of any other reason(s) attributable to the Seller.
- vi. Assignment, transfer, sub-letting of Contract without BHEL's written permission resulting in termination of Contract or part thereof by BHEL.
- vii. If the Seller be an individual or a Sole Proprietorship, in the event of death or insanity of the Seller.
- viii. If the Seller/Contractor being an individual or if a partnership firm thereof, shall at any time be adjudged insolvent or shall have a receiving order for administration of his estate made against him or shall take any proceeding for composition under any Insolvency Act for the time being in force or make any assignment of the order/Contract or enter into any arrangement or composition with his creditors or suspend payment or if the firm dissolved under the Partnership Act;
- ix. If the Seller/Contractor being a Company is wound up voluntarily or by order of a Court or a Receiver, Liquidator or Manager on behalf of the debenture holders and creditors is appointed or circumstances have arisen which entitles the Court of debenture holder and creditors to appoint a receiver, liquidator or manager
- x. Non- Compliance to any contractual condition or any other default attributable to the Seller.

Such defaulting vendor/Seller shall not be eligible to participate in re-tendering conducted on account of risk purchase made due to fault of such vendor/Seller.

BHEL's right to go for Risk and Cost, Calculation of Risk and Cost amount & LD, recovery options to BHEL are given in detail in Annexure-V hereto.

ANNEXURE-V

(RISK AND COST CLAUSE)

1. BHEL reserves the right to terminate the contract or withdraw portion of work and get it done through other agency, at the risk and cost of the contractor *after due notice of a period of 14 days' by BHEL* in any of the following cases:
- i) If the Seller/Contractor fails to deliver the goods or materials or any instalment thereof within the period(s) fixed for such delivery or the Seller's poor progress of the supply/ services vis-a-vis delivery/execution timeline as stipulated in the Contract, backlog attributable to seller including unexecuted portion of supply does not appear to be executable within balance available period;
 - ii) Delivers goods or materials not of the contracted quality and failing to adhere to the contract specifications;
 - iii) Withdrawal from or repudiation/ abandonment of the supply/ services by Seller before completion as per contract or if the Seller refuses or is unable to supply goods or materials covered by the Order/Contract either in whole or in part or otherwise fails to perform the Order/Contract;
 - iv) Non-supply by the Seller within scheduled completion/delivery period as per Contract or as extended from time to time, for the reasons attributable to the Seller;
 - v) Termination of Contract on account of any other reason (s) attributable to Seller.
 - vi) Assignment, transfer, subletting of Contract without BHEL's written permission resulting in termination of Contract or part thereof by BHEL.
 - vii) If the Seller be an individual or a sole proprietorship Firm, in the event of the death or insanity of the Seller;
 - viii) If the Seller/Contractor being an individual or if a firm on a partnership thereof, shall at any time, be adjudged insolvent or shall have a receiving order for administration of his estate made against him or shall take any proceeding for composition under any Insolvency Act for the time being in force or make any assignment of the Order/Contract or enter into any arrangement or composition with his creditors or suspend payment or if the firm dissolved under the Partnership Act;
 - ix) If the Seller/Contractor being a company is wound up voluntarily or by order of a Court or a Receiver, Liquidator or Manager on behalf of the debenture holders and creditors is appointed or circumstances shall have arisen which entitles the Court of debenture holder and creditors to appoint a receiver, liquidator or manager;
 - x) Non-compliance to any contractual condition or any other default attributable to Seller.

1.1 Risk & Cost Amount against Balance Work:

Risk & Cost amount against balance work shall be calculated as follows:

$$\text{Risk \& Cost Amount} = [(A-B) + (A \times H/100)]$$

Where,

A= Value of Balance scope of Work (*) as per rates of new contract

B= Value of Balance scope of Work (*) as per rates of old contract being paid to the contractor at the time of termination of contract i.e. inclusive of PVC & ORC, if any.

H = Overhead Factor to be taken as 5

In case (A-B) is less than 0 (zero), value of (A-B) shall be taken as 0 (zero).

1.2 * Balance scope of work (in case of termination of contract):

Difference of Contract Quantities and Executed Quantities as on the date of issue of Letter for 'Termination of Contract', shall be taken as balance scope of Work for calculating risk & cost amount.

Contract quantities are the quantities as per original contract. If, Contract has been amended, quantities as per amended Contract shall be considered as Contract Quantities.

Items for which total quantities to be executed have exceeded the Contract Quantities based on drawings issued to contractor from time to time till issue of Termination letter, then for these items total Quantities as per issued drawings would be deemed to be contract quantities.

Substitute/ extra items whose rates have already been approved would form part of contract quantities for this purpose.

Substitute/ extra items which have been executed but rates have not been approved, would also form part of contract quantities for this purpose and rates of such items shall be determined in line with contractual provisions.

However, increase in quantities on account of additional scope in new tender shall not be considered for this purpose.

NOTE: In case portion of work is being withdrawn at risk & cost of contractor instead of termination of contract, contract quantities pertaining to portion of work withdrawn shall be considered as 'Balance scope of work' for calculating Risk & Cost amount.

1.3 LD against delay in executed work in case of Termination of Contract:

LD against delay in executed work shall be calculated in line with LD clause no. 16 of GCC, for the delay attributable to contractor. For limiting the maximum value of LD, contract value shall be taken as Executed Value of work till termination of contract.

Method for calculation of LD against delay in executed work in case of termination of contract" is given below.

- i. Let the time period from scheduled date of start of work till termination of contract excluding the period of Hold (if any) not attributable to contractor = T1
- ii. Let the value of executed work till the time of termination of contract = X
- iii. Let the Total Executable Value of work for which inputs/fronts were made available to contractor and were planned for execution till termination of contract = Y
- iv. Delay in executed work attributable to contractor i.e. $T2 = [1-(X/Y)] \times T1$
- v. LD shall be calculated in line with LD clause (clause 16) of the Contract for the delay attributable to contractor taking "X" as Contract Value and "T2" as period of delay attributable to contractor.

2. Recoveries arising out of Risk & Cost and LD or any other recoveries due from Contractor

Without prejudice to the other means of recovery of such dues from the Seller recoveries from the Seller on whom risk & cost has been invoked shall be made from the following:

- a) Dues available in the form of Bills payable to seller, SD, BGs against the same contract.
- b) Dues payable to seller against other contracts in the same Region/Unit/ Division of BHEL.
- c) Dues payable to seller against other contracts in the different Region/Unit/ division of BHEL.

In-case recoveries are not possible with any of the above available options, Legal action shall be initiated for recovery against contractor.

|

	<u>PRE-QUALIFICATION REQUIREMENTS</u>	PE-PQ-445-145-I001
		REVISION NO. 00 DATE 16.06.2022
		SHEET NO. 1 OF 1

PACKAGE: CONTROL VALVE (FEED CONTROL VALVE) PROJECT: 1x660 MW SAGARDIGHI TPS	
1.0	<p>a. Bidder should be Original equipment manufacturer (OEM) for CONTROL VALVE.</p> <p>b. In case bidder is not OEM, evaluation shall be done as following:</p> <ol style="list-style-type: none"> 1. If bidder happens to be Indian subsidiaries of foreign OEM, then the credentials of the foreign OEM can also be considered for meeting PQR. 2. If bidder happens to be Authorized channel partner or having a valid collaboration agreement / licensing agreement with some other company or being a Joint Venture Company, then the credentials of collaborator / licensing company / Principal company /JV partner can also be considered for meeting PQR as per scope of the work. The scope matrix shall include their respective roles including design vetting, manufacturing of critical component and warranty/guarantee. If bidder(s) qualifies on the basis of credentials of his principal/JV partner/Collaborator etc., then the principal/JV partner/Collaborator shall be responsible for overall design vetting and warranty/guarantee of the package.
2.0	<p>The Product being offered by the bidder should be in use successfully in power plant or any other industrial application for at least 1 (One) year. Bidder to submit either of following supporting documents for the product (control valve)</p> <p>(i) Minimum valve size = 6" (ii) Minimum pressure rating = ANSI #600 (iii) Minimum differential pressure(DP) = 50 Kg/cm²</p> <p>a. Copy of minimum 1 (One) Performance Certificate from end user / customer certifying that product has been running satisfactorily for 1 (One) year from date of commissioning to the date of application. The certificate should clearly indicate date of commissioning, date of issue of certificate and name/designation of the certificate issuer. Copy of purchase order & technical parameter to be attached along with the performance certificate.</p> <p style="text-align: center;">OR</p> <p>b. Copy of repeat orders from minimum 2 (Two) different purchasers. Order received by bidder from same purchaser with a gap of minimum 2 (Two) years shall be considered as repeat order. Copy of technical parameters for each order to be attached.</p>
3.0	Bidder to furnish experience list of last 5 years indicating customer name, purchase order reference, item supplied & year of supply to establish the continuity of business.
4.0	Bidder to submit all documents in English. If documents submitted by bidder are in language other than English, a self-attested English Translated document should also be submitted.

Prepared by:	Checked by:	Approved by:
SHIKHA THAKUR MGR-C&I	MAYANK KESHARWANI SR.MGR-C&I	S.C.SHARMA DGM-C&I

TECHNICAL SPECIFICATION
FOR
CONTROL VALVE WITH ACCESSORIES
(LOW LOAD FEED CONTROL VALVE)

(Pneumatically Operated)

SAGARDIGHI THERMAL POWER PROJECT
1 x 660 MW UNIT NO. 5, PHASE – III

VOLUME - IIB

SECTIONS-A, C & D

SPECIFICATION No: PE-TS-445-145-I801A



BHARAT HEAVY ELECTRICALS LIMITED
POWER SECTOR
PROJECT ENGINEERING MANAGEMENT DIVISION
NOIDA, INDIA

915507/2022/PS-PEM-C_I

FORM NO. PEM-6666-0



Sagardighi Thermal Power Project

1 x 660 MW Unit No. 5, Phase-III

Technical specification for
Control Valve with Accessories - Feed Control Valve
(Pneumatically Operated)

SPEC NO.: PE-TS-445-145-I801A

DOCUMENT NO.

VOLUME II B

SECTION

ISSUE NO. 2

REV. NO. 00

DATE: 16.06.2022

CONTENTS

VOL-II B

SECTION	DESCRIPTION	PAGE NO.
A	Scope of Enquiry	3
C	Specific Technical Requirements	6
	Customer's Specification	11
	Datasheets-A&B (Data sheet no. PES-145-06-DS1-1)	24
	Datasheets-C (Data sheet no. PES-145-06-DS2-1)	28
	Quality Plan	32
	Bill of Quantity - Main Supply	40
	Bill of Quantity – Spares	42
D	Equipment Specification (PES – 145 – 06)	45
	Specification for Smart Positioner (PES – 145 – 06A)	51
	Hook-Up Diagram (PES-145-06B)	55
	Guideline for Packing (PES-145-06C)	58
	Sub Vendor List	60



Sagardighi Thermal Power Project

1 x 660 MW Unit No. 5, Phase-III

Technical specification for
Control Valve with Accessories - Feed Control Valve
 (Pneumatically Operated)

SPEC NO.: PE-TS-445-145-I801A

DOCUMENT NO.

VOLUME II B

SECTION A

ISSUE NO. 2

REV. NO. 00

DATE: 16.06.2022

SECTION – A

SCOPE OF ENQUIRY



Sagardighi Thermal Power Project

1 x 660 MW Unit No. 5, Phase-III

Technical specification for
Control Valve with Accessories - Feed Control Valve
(Pneumatically Operated)

SPEC NO.: PE-TS-445-145-I801A

DOCUMENT NO.

VOLUME II B

SECTION A

ISSUE NO. 2

REV. NO. 00

DATE: 16.06.2022

SCOPE OF ENQUIRY

1. SCOPE

- 1.1 This specification covers the Design, Manufacture, Inspection and testing at manufacturer's works, proper packing for transportation and delivery to site of the **Control Valves with Pneumatic Actuator along with Accessories, Start-up/Commissioning Spares & Mandatory spares** as mentioned in different sections of this specification for **Sagardighi TPP**, 1 x 660 MW Unit No. 5, Phase-III.
- 1.2 The quality plan enclosed forms the minimum requirement but not limited to be adhered to by the bidder. Bidder to sign and stamp the same and submit along with the offer as an acceptance.
- 1.3 Following signed & stamped documents with company seal to be submitted by bidder.
- Complete offer including calculation sheets, catalogues etc.
 - Quality Plan
 - Datasheet A & B, duly filled
 - Schedule of prices & unit prices, inspection schedule
 - Schedule of submission of drawings/documents, equipment manufacture, inspection & dispatch.

2 GENERAL TECHNICAL INSTRUCTIONS

- 2.1 It is not the intent here to specify all the details of design and manufacture. However, the equipment shall conform in all respects to high standard of design, engineering and workmanship and shall be capable of performing the required duties in a manner acceptable to the customer / consultant, who will interpret the meaning of drawing and specification and shall be entitled to reject any component or material which in his judgment is not in full accordance herewith.
- 2.2 The omission of specific reference to any component / accessory necessary for the proper performance of the equipment shall not relieve the supplier of the responsibility of providing such facilities to complete the supply within the quoted prices.
- 2.3 BHEL' s / Customer' s representatives shall be given access to the shop in which the equipment are being manufactured or tested and all test records shall be made available to them.
- 2.4 The Equipment covered under this specification shall not be dispatched unless the same have been finally inspected, accepted and Material Dispatch Clearance Certificate (MDCC) is issued by BHEL / Customer.



Sagardighi Thermal Power Project

1 x 660 MW Unit No. 5, Phase-III

Technical specification for
Control Valve with Accessories - Feed Control Valve
(Pneumatically Operated)

SPEC NO.: PE-TS-445-145-I801A

DOCUMENT NO.

VOLUME II B

SECTION C

ISSUE NO. 2

REV. NO. 00

DATE: 16.06.2022

SECTION – C

- **SPECIFIC TECHNICAL REQUIREMENT**
 - **CUSTOMER’S SPECIFICATION**
 - **DATA SHEETS – A & B**
- **DATA SHEETS– A & B FOR ACCESSORIES**
 - **DATA SHEETS – C**
 - **QUALITY PLAN**
 - **BOQ-MAIN SUPPLY**
 - **BOQ- SPARES**

	<p align="center">Sagardighi Thermal Power Project 1 x 660 MW Unit No. 5, Phase-III</p> <p align="center">Technical specification for Control Valve with Accessories - Feed Control Valve (Pneumatically Operated)</p>	SPEC NO.: PE-TS-445-145-I801A	
		DOCUMENT NO.	
		VOLUME	II B
		SECTION	C
		ISSUE NO. 2	
		REV. NO. 00	DATE: 16.06.2022

SPECIFIC TECHNICAL REQUIREMENTS

The requirements in this section are specific for this project and shall over-ride the specification under Section-D in case of any contradiction. However, in case of any contradiction between this SPECIFIC TECHNICAL REQUIREMENTS and customer SPECIFICATION attached further, the customer SPECIFICATION shall prevail and BHEL's decision shall be final. BIDDER to comply the stringent requirement as per BHEL decision without any commercial implication.

1. **All the formats in QUALITY PLAN (BHEL Format) should filled-up and furnished with the bid, complete in all respect. In the absence of those, the bid would be considered incomplete and liable for rejection.** Catalogue, Leaflets related with the models of Control Valves as well as each Accessory must be furnished with the offer.
2. The Hook-up diagram for Control valve, attached in Section-D. The scope demarcation as indicated should be adhered. The connection details at Instrument Air valve shall be furnished to successful bidder after the award of contract.
3. Valve Body Sizes shall be quoted to take care of the specification requirements like parameters, and limitations of Fluid outlet velocities, Noise Level etc. **However, Port (Trim) Sizes shall be selected to suit CV requirement for achieving percentage valve lift as per Technical Specification.**
4. Bidder to note that, **wherever downstream side of the valve is subjected to the Vacuum service, bidder to offer double Gland packing, and in that case, flow direction of working fluid shall be to close the valve.** Separate indication for the same has not been made in the data Sheets-A.
5. For valves subjected to cavitation service, anti-cavitation trim shall be provided.
6. In case during erection/commissioning of the control valve, any spares are required which have not been specified in the Start-up/commissioning spares list, the same will have to be supplied by the bidder free of cost.
7. Facility to adjust the maximum travel of the stem & starting point of travel shall be incorporated.
8. SS name plate for control valve shall include Tag no./ KKS no./ Sl. No./ Body material/ size/ Press Rating/ Trim material/ Trim type/ action on air failure/ diaphragm air press at full open and close condition
9. Hand wheel shall have open/ close direction.
10. Limit switch shall be designed for 1,00,000 operations.

	Sagardighi Thermal Power Project 1 x 660 MW Unit No. 5, Phase-III Technical specification for Control Valve with Accessories - Feed Control Valve (Pneumatically Operated)	SPEC NO.: PE-TS-445-145-I801A	
		DOCUMENT NO.	
		VOLUME	II B
		SECTION	C
		ISSUE NO. 2	
		REV. NO. 00	DATE: 16.06.2022

11. JB shall be 36 ways as per enclosed hook-up diagram.
12. The material of filter for Air Filter Regulator shall be sintered bronze.
13. Bidder to indicate pick-up & drop out voltage for all solenoid valves.
14. Protection class for Limit switches, Smart Positioner shall be IP-65 only.
15. All JBs and valves shall be with double compression type Ni plated brass cable glands.
16. Solenoid valve class of protection shall be IP-65, shall be of Plug and socket electrical connection.
17. All local cabling up to JBs shall be in Conduit (Flexible/Rigid).
18. Control valve accessories shall be fitted on the valve body. Junction box shall be mounted on the valve body.
19. The smart positioner provided with Control Valves shall be compatible with Universal Hart Calibrator.
 In order to interface with METSO system, the smart positioner of Control Valves has to be HART Compatible. Bidder to provide diagnostic software (for all tags) to be installed on HMS PC for communicating with the smart positioner and accessing the diagnostic features of the smart positioner. Bidder to offer latest version of calibration and diagnostic software which should be compatible with latest operating system at the time of commissioning of valve/ positioner without any additional cost to BHEL. The offered software shall be compatible with the HART MANAGEMENT SYSTEM hardware of reputed makes like MTL, P&F etc. Additionally, Vendor to provide DTM (device type manager) / DTD (device type description) files for engineering.
20. Positioner shall have both fail freeze and fail safe feature.
21. Tolerances on end to end, centre to centre, centre to face shall be in accordance with ASME B16.10.
22. The final documentation including operating manuals, maintenance and service manuals, component documentation, assembly documentation, drawings and listing, etc. shall be submitted in English language.
23. Multi-stage multi path valves shall be used for high DP valve i.e. Feed Control Valve – FDV 14.
24. Valve and actuator shall be designed for full differential pressure (Max. shut-off pressure).

	Sagardighi Thermal Power Project 1 x 660 MW Unit No. 5, Phase-III Technical specification for Control Valve with Accessories - Feed Control Valve (Pneumatically Operated)	SPEC NO.: PE-TS-445-145-I801A	
		DOCUMENT NO.	
		VOLUME	II B
		SECTION	C
		ISSUE NO. 2	
		REV. NO. 00	DATE: 16.06.2022

25. In order to prevent the risk of fire or explosion pneumatic actuators shall be used in hazardous areas and associated equipment (e.g. positioners) must be intrinsically safe in accordance with IEC 60079-11.

26. Bidder to furnish **compliance certificate** duly signed and stamped by bidder attached further.

27. SPARES: The following spares are required to be offered

(A) Recommended Spares:

The bidder shall furnish a List of Recommended spares for 3 years of normal operation of the Control valves / Accessories. The BHEL/Customer reserves the right to buy any or all of the recommended spares.

The prices of these spares will remain valid for a period of minimum 6 months after the placement of order.

(B) Start-up & Commissioning Spares:

Start-up and Commissioning spares are those spares, which may be required during the start-up and commissioning of the Control Valves. All start-up spares, which are supplied under this contract, shall be strictly interchangeable with the parts for which they are intended for replacements.

The Start-up and commissioning spares indicated by the bidder shall be a part of the main Control valves supply. However, bidder to indicate prices separately. The list of these spares required is enclosed in the Section-C of this specification.

Bidder to indicate the service life expectancy period for the spare parts under normal working conditions. The spares shall be treated and packed for long storage, under climatic conditions prevailing at site. Small items shall be packed in sealed transparent plastic bags with desiccator's packs as necessary.

(C) Mandatory spares:

Bidder to supply mandatory spares as attached in specification.



Sagardighi Thermal Power Project

1 x 660 MW Unit No. 5, Phase-III

Technical specification for
Control Valve with Accessories - Feed Control Valve
(Pneumatically Operated)

SPEC NO.: PE-TS-445-145-I801A

DOCUMENT NO.

VOLUME II B

SECTION C

ISSUE NO. 2

REV. NO. 00

DATE: 16.06.2022

28. Documentation:

(A) After the award of contract:

The documentation as listed below for the project
6 sets of the following documents + 3 sets of CDs to be enclosed with the bids for
Approval:

- a. Assembly (dimensional) drawings.
- b. Valve Edge preparation details.
- c. Data sheet-C completely filled-up.
- d. Hook-up diagram of Control Valve with Actuator & Accessories.
- e. Valve & Actuator assembly dimensional drawings with weights.
- f. Quality Plan duly signed and stamped.
- g. All calculations like CV, Noise Level, Valve Outlet Velocity, Actuator sizing etc.
- h. All relevant catalogues for the models of the valves as well as accessories finalized.
- i. Bar chart to indicate the time schedule for procurement, manufacture, testing and dispatch.

(B) Final documentation:

The documentation as listed below will separate for respective projects

1. Category –I & IV Approved final drawings/data sheets, – 20 sets with 4 CD-ROMS
Valve sizing calculations, Noise level calculations and
Valve Outlet Velocity calculations.
2. Test certificates – 20 sets.
3. Operation & Maintenance Manuals – 20 sets with 4 CD-ROMS
for Control Valve, Actuator and all the
Accessories.



Sagardighi Thermal Power Project

1 x 660 MW Unit No. 5, Phase-III

Technical specification for
Control Valve with Accessories - Feed Control Valve
(Pneumatically Operated)

SPEC NO.: PE-TS-445-145-I801A

DOCUMENT NO.

VOLUME II B

SECTION C

ISSUE NO. 2

REV. NO. 00

DATE: 16.06.2022

COMPLIANCE CERTIFICATE

We shall comply with the following: -

- All the requirements as stated in Technical Specification / Specific Technical requirement / Data sheets / Drawings, BHEL quality plan etc. as enclosed in the tender, shall be fully complied **without any deviation**.
- BHEL Quality Plan (enclosed with the specification) duly signed and stamped is submitted herewith **without any deviation**.
- Calculation of CV, Noise level, Valve outlet velocity, Trim exit velocity, Actuator sizing, Data Sheet-C in line with Data sheet-A of specification, dimensional drawings / edge preparation details, etc shall be submitted for BHEL/Customer review and approval, to reach BHEL within 15 days after receipt of LOI.
- Selection of valves and Actuators are our (bidder's) responsibility. Any change in selection of type of valve and Actuators / Sizing / percentage opening, calculations, QP, etc., if desired by BHEL / Customer during approval of the documents after award of contract, without major changes in process parameters as per tender Specification, shall be carried out without any commercial implication and time delay.
- Body material and Trim material combinations offered will be equivalent or better than the material specified in data Sheet-A. Wherever Trim material combinations offered differ from the specification, its superiority shall be authenticated with documentary evidence and justification produced for BHEL / Customer's concurrence. BHEL / Customer reserves the right to accept/rejects any variation to the specification.

**(To be Signed & Stamped by
the Bidder)**

Signature with date	
Name	
Company seal	

FORM NO. PEM-666-0



Sagardighi Thermal Power Project

1 x 660 MW Unit No. 5, Phase-III

Technical specification for
Control Valve with Accessories - Feed Control Valve
(Pneumatically Operated)

SPEC NO.: PE-TS-445-145-I801A	
DOCUMENT NO.	
VOLUME	II B
SECTION	C
ISSUE NO.	2
REV. NO. 00	DATE: 16.06.2022

CUSTOMER SPECIFICATION



4.00.00 CONTROL VALVES, ACTUATORS & ACCESSORIES

4.01.00 GENERAL REQUIREMENTS

4.01.01 Bidder shall exercise extreme caution in selecting severe service control valves like BFP recirculation valves, HP & LP bypass valves, superheater & reheater attemperator valves, PRDS valves for Boiler & Turbine, Soot blower steam pressure control valve, control valves whose down stream are connected to condenser and in vacuum such as HP/LP heater emergency level control, condenser make up water control valve and CEP minimum flow control valve etc. For such critical applications, Bidder shall offer valves which are proven for similar application for not less than 2 years of continuous service in power plant environment. All the above valves shall have leakage class equal or better than class-V or as specified hereunder with metal-to-metal seating. For Severe Service Control Valves viz. BFP Recirculation Valves, PRDS Valves, Feed Control Valve, SH/RH Attemperation valve, Soot blower steam pressure control valve etc. multistage-multipath discrete pressure drop design shall be provided. HP and LP Bypass valves shall be designed for 60% bypass capacity with twin valves. Typical Requirements for these Control Valves shall be as follows:

Service	:	BFP Recirculation Valve/RH-SH Attemperator Valves
Type	:	Multi Stage, Multi Path stack Plate radial Flow design
Trim	:	Angle Design (side inlet and bottom outlet, over the plug flow) or Globe design (for straight pipe)
Trim exit <i>velocity</i>	:	Not exceeding 23m/sec
Pressure reducing /drop	:	Achieved in multi stage orificed, drilled hole or axial flow cage design
Seat Leakage	:	In accordance with MSS-SP-61
Actuator type	:	Pneumatic Piston type ensuring MSS-SP-61 seat leakage

4.01.02 Control valves for regulating service shall normally be globe body, cage guided, metal-to-metal seated, pneumatically operated and shall be provided with characterized plugs having ANSI leakage class-IV as minimum. All steam temperature conditioning control valves shall be ANSI leakage class-V.





- 4.02.00 VALVE CONSTRUCTION
- 4.02.01 All valves shall generally be of globe body design and straight through pattern with single seat unless otherwise is specified or recommended by the manufacturer for particular application. However, Bidder may offer angle body valve for high pressure drop applications. For high pressure drop applications, construction of the valve shall be such that the gland is not exposed to full line pressure.
- 4.02.02 Valves with high lift cage guided plugs and quick replacement trims shall be provided for easy maintenance.
- 4.02.03 Plug shall be one piece construction either cast, forged or machined from solid stock. Plug shall be screwed and pinned to valve stem or shall be integral with valve stem.
- 4.02.04 Bonnet joint shall be of flanged and bolted type or manufacturer standard acceptable to Owner. Bonnet joints of internal threaded or union type is not acceptable.
- 4.02.05 Extension Bonnet shall be provided for fluid temperature above 280 deg C.
- 4.02.06 Valve characteristics shall match with the process characteristics.
- 4.02.07 All valves connected to vacuum on down stream side shall be provided with packing suitable for vacuum application (i.e. double vee type chevron packing).
- 4.02.08 Flanged valves shall have minimum body rating ANSI 300 lbs.
- 4.02.09 The direction of flow shall be clearly marked/engraved on the body.





4.02.10 Valve body rating shall meet the process pressure and temperature requirement as per ANSI B 16.34.

4.03.00 VALVE BODY

Valve body material shall generally be guided as per the Table below:

<u>SR. NO.</u>	<u>SERVICE</u>	<u>BODY MATERIAL</u>
1.	Non corrosive, non-flashing and non cavitating service for fluid temperature upto 275°C (like Aux steam flow to Deaerator, condensate flow to Deaerator, CRH flow to Deaerator)	Compatible with piping material but not inferior to Cast carbon steel ASTM A216 Gr. WCB
2.	Severe flashing / cavitating services (like HP & LP heaters emergency drain, Deaerator overflow drain to hotwell etc.)	Alloy steel as per ASTM A217 Gr. WC9
3.	Low flashing / cavitating services (like HP & LP heaters normal drain level control, GSC minimum flow, gland seal steam pressure control etc.)	Alloy steel as per ASTM A217 Gr. WC6
4.	DM water application (like condenser hotwell normal and emergency make up, ECW DP control etc.)	316 stainless steel ASTM A351 Gr. CF8M

4.04.00 VALVE TRIM

4.04.01 Valve trim for most applications up to leakage class-V shall be stainless steel 316 SS for pressure drop up to 7 Kg/ Sq. cm.. For pressure drops above 7 Kg/Sq. cm hard trim (stelliting or equivalent) shall be used. Other alloys shall be substituted if required for corrosion and other fluid conditions.

4.04.02 Balanced trim valves shall be offered for high shut-off pressure or high pressure drop condition to reduce the size of the actuators. For flashing services and two stage mixtures, the trim material shall be 17-4 PH or equivalent. If cavitating condition is foreseen, Bidder shall offer multistage or labyrinth trim valves. Trim of severe service valves as indicated in Cl. 4.01.01 shall be of multistage and multipath design with sufficient no. of discrete





pressure drop stages to eliminate the chances of erosion, cavitation, noise and vibration throughout the control range of the valve.

4.04.03 Quick replacement type trim shall be considered for easy maintenance.

4.04.04 Trim Material

Valve trim material shall generally be guided as per the Table below :

SR. No.	SERVICE	MATERIAL
1.	Non corrosive, non-flashing and non cavitating service for fluid temperature upto 275°C.	316 SS with satellite faced guide posts and bushings
2.	Severe flashing / cavitating services	400 series SS or equivalent to suit the specific requirement
3.	Low flashing / cavitating services	400 series SS or equivalent to suit the specific requirement
4.	DM water application (condenser hotwell normal, emergency make up etc.)	316 SS

cavitation resistance, corrosion resistance, temperature resistance, erosion resistance, hardness etc. of the offered material vis-à-vis the specified material for Bidder may offer valves with body and trim material better than the specified material and in such cases Bidder shall furnish the comparison of properties including Owner's approval.

4.05.00 VALVE END PREPARATION

Valve body ends shall be either butt welded/socket welded, or flanged (Rubber lined for condensate service). Control valves of size 65 mm and above shall have butt welded ends as per ANSI B 16.25. For valve size 50 mm and below welded ends shall be socket welded as per ANSI B 16.11. Flanged ends shall be of ANSI pressure-temperature class equal to or greater than that of control valve body.

4.06.00 VALVE SIZE

The control valve sizing (Cv / Kv) shall be based on following guidelines :

- The valves shall pass normal rate of flow (MCR condition) with 65 to 75 percent opening for linear characterised valves and 75 to 85 percent opening for equal percentage characterised valves.
- The valves shall have adequate rangeability to pass the minimum and maximum rated flows at 10% and 80% of the valve opening





respectively. Valve stem travel range from minimum to maximum flow condition shall not be less than 50% of the total valve stem travel.

- c) Valve Cv shall be selected in such a way that the valve shall be capable of handling at least 120% of required rated flow.
- d) The valve selection shall be based on the highest size dictated by the above considerations unless noise, flashing or other factors dictate the final selection.
- e) The sizing procedure followed shall be as per latest edition of ANSI/ISA or equivalent standard.
- f) While deciding the valve size, Bidder shall ensure that valves port outlet velocity does not exceed 8 m/sec for liquid services, 150 m/sec for steam services and 50% of sonic velocity for flashing services.
- g) Control valve induced noise shall not greater than 85 dBA at 1 meter from the valve surface under actual operating conditions. The noise abatement shall be achieved by valve body and trim design and not by use of silencers.
- h) Bidder shall submit the sizing calculation clearly indicating the valve outlet velocity, noise calculation during detail engineering stage for Owner's approval.

4.07.00 VALVE TOPWORK

4.07.01 Topwork shall be sized so that the valve shall operate properly when upstream pressure is 10 percent above maximum inlet pressure and downstream pressure is atmospheric.

4.07.02 Bonnet material shall be same as that of valve body or equivalent forged material.

4.07.03 Extended bonnet/Finned bonnet and high temperature packing shall be used for high temperature application. Extension bonnet shall be used when the fluid temperature is high and may damage valve stem packing.

4.07.04 The gland material shall be chosen to suit the operating temperature. PTFE may be chosen for low temperature application and for high temperature application graphited asbestos glands are to be provided. For vacuum services, the glands shall be dry seal type.

4.08.00 NOISE LEVEL

The equivalent sound level measured at 1.5 M above nearest floor level in elevation and 1 M horizontally from the control valve expressed in decibels to a reference of 0.0002 microbar shall not exceed 85 dBA. If the calculated noise is more than the above limit, even with low noise trim design, diffusers shall be included. Diffusers shall be made of stainless steel and shall be integrally connected to the control valve with necessary spool piece. The spool piece shall be in conformity with the main line piping specification.





- 4.09.00 VALVE ACTUATORS
- 4.09.01 Spring-diaphragm type valve actuators shall be used in general applications. However piston type actuators shall be offered in case of high shut-off pressure & quick response requirement. Bidder shall provide piston type actuators for regulating services for the following services as a minimum requirement. Piston actuator shall be of double acting type for the regulating duty valves with long stem travel for better regulation and quick response.
- a) Auxiliary Pressure reducing & De-super heating stations.
 - b) Superheat and Reheat Spray Control Valves.
 - c) Condensate extraction pump minimum recirculation valve.
 - d) Feed control valves
- 4.09.02 The actuator shall be designed for 150% thrust required for the valve (at shut-off pressure) at an air line supply pressure of 5.5 Kg/Sq. cm.
- 4.09.03 All the actuators shall be supplied mounted on the valve with all the accessories integrally mounted. The diaphragms shall be designed for 200% maximum operating pressure.
- 4.09.04 Nylon reinforced neoprene shall be used as diaphragm material.
- 4.09.05 Valve actuators shall be capable of operating at 60 deg C ambient, continuously.
- 4.09.06 Entire actuator assembly shall be painted with corrosion inhibiting paint.
- 4.09.07 Air connection size shall be 1/4" NPT (F) unless otherwise dictated by process response time. Integral tubing shall be of stainless steel construction.
- 4.09.08 Bidder shall indicate the stroking time of the valve assemblies with positioner, which shall not exceed 10 sec unless otherwise stated.
- 4.09.09 All actuators shall be of fail safe design signifying that the spring direction will tend to move the valve (open or close) in a direction safe for the process. "Failure to Open" or "Failure to Close" shall be marked on the actuator.
- 4.09.10 HP and LP bypass and spray valves, turbine inlet stop & control valves shall be electro-hydraulic actuators and all other control valves shall have pneumatic actuators.
- 4.10.00 VALVE POSITIONERS
- 4.10.01 All regulating service valves shall be offered with HART protocol based Smart Electro Pneumatic Positioners to ensure accuracy and repeatability of response.
- 4.10.02 Positioners shall have integral I-P converter, Position feedback transmitter, input and output gauges, local keypad & display .





- 4.10.03 Positioners shall be capable of functioning under hot, humid and vibrating conditions.
- 4.10.04 Positioner casings shall be dust tight, corrosion resistant and weatherproof (IP-55).
- 4.10.05 In general, positioner shall operate at signal range 4 – 20 mA DC for the full travel of the valve. Split range operation in few cases may be required. Remote calibration from control room shall be possible through HART management station.
- 4.11.00 VALVE ACCESSORIES
- The accessories of the valves shall include side mounted hand wheels, smart positioner, limit switches, tubing and air set, junction boxes, airlock relays, volume booster, solenoid valves, and any other devices as required.
- 4.12.00 TESTS
- All valves shall be tested in accordance with the Quality Assurance Programme (QAP). Bidder shall submit QAP for Owner's approval. The tests shall include but not be limited to the following :
01. Non destructive test as per ANSI B 16.34.
 02. Hydrostatic shell test as per ANSI B 16.34 prior to seat leakage test.
 03. Valve closure test and seat leakage test as per ANSI B 16.34 and as per the leakage class
 04. Functional test : The fully assembled valves with actuator and all accessories shall be functionally tested to demonstrate from open to close position and vice versa. Valve lift shall be checked at 5 points at 0, 25, 50, 75 and 100% in both the directions with increasing and decreasing inputs. Performance of the valve with Positioner shall be as follows :
 - a. Linearity : +/- 1%
 - b. Hysteresis : +/- 1%
 - c. Sensitivity : +/- 0.5%
 - d. Deadband : +/- 1%
 - e. Reproducibility : 0.3% of total stroke
 - f. Overall accuracy : +/- 1%
 05. CV test : Cv test shall be carried out as type test on each size, type and design of the valves as per ISA 75.02 standard and test report shall be submitted for Owner's approval.



**4.00.00 GENERAL TECHNICAL REQUIREMENTS**

- 4.07.00 Final control device for regulating control shall have pneumatic actuator. Actuators for isolating and inching duty dampers and valves shall be, in general, electrical motor operated. Generally pneumatic actuators for ON-OFF services shall not be considered unless process requirement demand to use same. Actuators for isolating and inching duty type dampers/valves shall have limit switch. SMART positioner along with position transmitter (4 - 20 mA output) and limit switches shall be provided for all types of control valves. SMART positioners shall be HART compatible. Hydraulic operated control valves shall also be operated from DCS in addition to the local control. All control valves shall have motorised isolation valve in the upstream and downstream line. Moreover the bypass line shall be provided.





- 1.22.00 Air Filter Regulator
01. Filter Element : Sintered Bronze
 02. Filter Size : 5 microns
 03. Input Air : 10.0 Kg/Sq. cm (maximum)
 04. Output : Adjustable from 0-2.0 Kg / Sq. cm or 0-7.0 Kg / Sq. cm (continuous) as applicable.
 05. Effect of Supply : Maximum 0.02 Kg/Sq. cm for a change pressure variation in supply pressure of 4 Kg/Sq. cm
 06. Bowl Material : Metallic.
 07. Accessories : 2" dial size output pressure gauge
 08. Feature : No perceptible drop of pressure on opening the drain port.
- 1.23.00 SOLENOID VALVE
01. Operating Principle : Electromagnetic (noiseless)
 02. Coil voltage rating : 24V DC (in general) other 220V DC /240V AC /110V AC as required





WBPDC

EPC Bid Document
Sagardighi Thermal Power Project
1x660 MW Unit No. 5, Phase - III

- | | | | |
|-----|---------------------|---|---|
| 03. | Ways | : | 3 ways in general other depending on requirement |
| 04. | Port size | : | 1/4" NPT all ports |
| 05. | Body | : | SS Bar Stock |
| 06. | Trim | : | AISI SS-316 |
| 07. | Manual Operator | : | In built |
| 08. | Duty | : | Suitable for continuous energization |
| 09. | Sealing | : | Airtight and leak proofing with nitrile (NBR) and polyurethane (PUR) material |
| 10. | Ambient Temperature | : | 0 - 50° C |
| 11. | Fluid Temperature | : | 0-150° C (approx.) |
| 12. | Coil Enclosure | : | Stainless Steel |
| 13. | Insulation | : | Class-H |
| 14. | Coil Casing | : | IP-65 (Explosion proof for NEC Class-1, Division-1 area) |
| 15. | Response time | : | 4-7msec |
| 16. | Mounting | : | On pipe or on panel |
| 17. | Cable Connection | : | ½" NPT cable gland |
| 18. | Accessories | : | Mounting brackets, nuts and bolts |
| 19. | Special feature | : | (i) LED indication for power

(ii) Double coil type for open & close operation of valve / damper.

(iii) Solenoid valve directly integral to actuator body shall have NAMOOR interface for uniformity |





1.42.00	SMART POSITIONER	
01.	Type	: Universal design (linear or rotary application)
02.	Input Signal	: 4-20mA DC , 2 wire loop with 24V DC.
03.	Output Signal (position F/B)	: i) 4-20mA ii) Configurable end position switch
04.	Supply Pressure	: Single acting 1.2 to 7.0 bar Double acting 1.2 to 10.5 bar
05.	Air Delivery	: Single acting 10.0 SCFM at 2.1 bar supply Double acting 7.2 SCFM at 2.1 bar supply
06.	Housing	: IP 65
07.	Repeatability	: +/- 0.3% of span or better
08.	Accuracy	: +/- 0.1% of span or better
09.	Communication	: Hart protocol
10.	Power-up with position	: < 150 ms or better control
11.	Power interruption without reset	: <100ms or better
12.	Body Material	: Aluminium
13.	Response Time	: Less than 10 sec





5.04.04 Junction Box

Junction boxes shall be of metallic construction.

- a) Junction box shall be provided with front opening type cover. Junction box shall be of sheet steel construction with thickness not less than 2 mm. Junction box shall be complete with DIN rail mounted terminals, MCB, receptacles and earth bar. Earth bar shall be made of tinned copper of 25 X 6 MM size. Earth stud shall be furnished for safety grounding.
- b) Terminals shall be screwless cage-clamp type and 20% spare terminals shall be furnished. Power terminals shall be screw type.



915507/2022/PS-PEM-C_I

FORM NO. PEM-6666-0



Sagardighi Thermal Power Project

1 x 660 MW Unit No. 5, Phase-III

Technical specification for
Control Valve with Accessories - Feed Control Valve
 (Pneumatically Operated)

SPEC NO.: PE-TS-445-145-I801A

DOCUMENT NO.

VOLUME II B

SECTION C

ISSUE NO. 2

REV. NO. 00

DATE: 16.06.2022

SECTION-C

DATASHEET A&B

BHEL PEM	DATA SHEET FOR CONTROL VALVES (WITH PNEUMATIC ACTUATOR)		SPECIFICATION NO.: PE-TS-445-145-I104			
			VOLUME			
			SECTION			
			REV. NO. 03		DATE: 17.05.2022	
		SHEET 56 OF 62				
Tag No. : Applicable for all tag nos. Quantity: As required Data Sheet No. PES-145-06-DS1-1						
APPLICABLE FOR TAG NOS.WHEREVER STATEMENT “REQUIRED” INDICATED IN THE INDIVIDUAL CV DATA SHEETS						
DATA SHEET – A & B for ACCESSORIES						
DATA SHEET – A FOR CONTROL VALVE (WITH PNEUMATIC ACTUATOR) (TO BE FILLED BY PURCHASER)					DATA SHEET – B (TO BE FILLED-UP BY BIDDER)	
POSITIONER	MFR. & MODEL NUMBER			BIDDER TO SPECIFY		
	BYPASS	GAUGES	ENCL. CLASS	<input type="checkbox"/> YES <input checked="" type="checkbox"/> NO	<input type="checkbox"/> THREE <input checked="" type="checkbox"/> TWO <input checked="" type="checkbox"/> IP-65	
	INPUT SIGNAL			4-20 mA DC		
	OUTPUT SIGNAL (Kg / Cm ²)			TO SUIT ACTUATOR		
AIR FILTER REGULATOR	MFR. & MODEL NUMBER			BIDDER TO SPECIFY		
	AIR SUPPLY PRESS (Kg / Cm ² g)			<input checked="" type="checkbox"/> 5.0 – 7.0 <input type="checkbox"/>		
	OUTPUT PRESS (Kg / Cm ² g)			TO SUIT ACTUATOR		
	FILTER SIZE			5 MICRON		
	OUTPUT GAUGE			<input checked="" type="checkbox"/> REQUIRED <input type="checkbox"/> NOT REQUIRED		
AUTO DRAIN FEATURE			<input checked="" type="checkbox"/> REQUIRED <input type="checkbox"/> NOT REQUIRED			
AIR LOCK	MFR. & MODEL NUMBER			BIDDER TO SPECIFY		
	SET PRESS (Kg / Cm ²)					
	SUPPLY PRESS (Kg / Cm ²)			<input checked="" type="checkbox"/> 5.0 – 7.0 <input type="checkbox"/>		
	RESET TYPE			AUTO		
VENT PLUG			REQUIRED			
LIMIT SWITCH	MFR. & MODEL NUMBER			BIDDER TO SPECIFY		
	OPEN posn	INT posn	CLOSE posn	1 NO.	1 NO.	
	CONTACT TYPE			SPDT		
	RATING (AC / DC)			5A 240V AC AND 0.5A 220V DC		
	ENCLOSURE CLASS			<input checked="" type="checkbox"/> IP 65 <input type="checkbox"/> NEMA-4		
POSITION TRANSMITTER	MFR. & MODEL NUMBER			BIDDER TO SPECIFY (Part of SMART Positioner)		
	TYPE			<input checked="" type="checkbox"/> Electronic (2-Wire) Contactless <input type="checkbox"/> OTHER		
	SUPPLY			<input checked="" type="checkbox"/> 24V DC <input type="checkbox"/> 220V DC <input type="checkbox"/> 110V AC <input type="checkbox"/> 240V AC		
	OUTPUT RATING			<input checked="" type="checkbox"/> 4-20mA <input type="checkbox"/> 0-100 ohms		
	ACCURACY			± 1% FS		
	ENCLOSURE CLASS			<input checked="" type="checkbox"/> IP 65 <input type="checkbox"/> NEMA-4		
SOLENOID VALVE	MFR. & MODEL NUMBER			BIDDER TO SPECIFY		
	RATING			<input checked="" type="checkbox"/> 24V DC <input type="checkbox"/> 220V DC <input type="checkbox"/> 240V AC <input type="checkbox"/>		
	TYPE			3-WAY (UNIVERSAL OPERATION TYPE)		
	OPERATION	QUANTITY		<input type="checkbox"/> Stayput <input checked="" type="checkbox"/> Interlock	<input checked="" type="checkbox"/> 1 <input type="checkbox"/> 2	
	COIL INSULATION CLASS			CLASS - H		
	ENCLOSURE CLASS			<input checked="" type="checkbox"/> IP 65 <input type="checkbox"/> NEMA 4 <input type="checkbox"/>		
HANDWHEEL	ORIENTATION			<input type="checkbox"/> TOP MOUNTED <input checked="" type="checkbox"/> SIDE MOUNTED		
JUNCTION BOX	NO. OF WAYS			<input type="checkbox"/> 24-WAYS <input type="checkbox"/> AS REQUIRED <input checked="" type="checkbox"/> 36-Ways		
	SIZE			AS REQUIRED		
	CABLE GLANDS (Size / Quantity)			AS REQUIRED (Double Compression Type).		
	ENCLOSURE CLASS			<input checked="" type="checkbox"/> IP 65 <input type="checkbox"/> NEMA-4		
BODY MATERIAL			<input type="checkbox"/> FRP <input type="checkbox"/> SS <input checked="" type="checkbox"/> METAL SHEET			
I/P CONVERTER (Part of SMART Positioner)	INPUT SIGNAL	POWER SUPPLY		4-20mA DC	24V DC	
	SPLIT RANGE			<input type="checkbox"/> YES <input type="checkbox"/> NO		
	ENCLOSURE CLASS			<input checked="" type="checkbox"/> IP 65 <input type="checkbox"/> NEMA-4		
VOLUME BOOSTER	MAKE. & MODEL NUMBER			BIDDER TO SPECIFY		
SS Tubing & Fittings / per CV	This is in addition to SS Tubing and fittings which are integral part of CV as per ASTM B68 to B75 (USA)			25 Meters of ¼” SS Tubing, with 1 set of Fittings for each CV for connection to IA Header on one end and accessories on another end of CV.		
PAINTING	COLOUR/SHADE			<input checked="" type="checkbox"/> RED <input type="checkbox"/> GREEN <input type="checkbox"/>		
	THICKNESS (DFT) – in microns			80-100		
	TYPE			<input checked="" type="checkbox"/> EPOXY <input type="checkbox"/> ENAMEL <input type="checkbox"/>		

915507/2022/PS-PEM-C_I

FORM NO. PEM-6666-0



Sagardighi Thermal Power Project

1 x 660 MW Unit No. 5, Phase-III

Technical specification for
Control Valve with Accessories - Feed Control Valve
 (Pneumatically Operated)

SPEC NO.: PE-TS-445-145-I801A

DOCUMENT NO.

VOLUME II B

SECTION C

ISSUE NO. 2

REV. NO. 00

DATE: 16.06.2022

SECTION-C

DATASHEET C



Sagardighi Thermal Power Project

1 x 660 MW Unit No. 5, Phase-III

Technical specification for Control Valve with Accessories - Feed Control Valve (Pneumatically Operated)

SPEC NO.: PE-TS-445-145-I801A

DOCUMENT NO.

VOLUME II B

SECTION C

ISSUE NO. 2

REV. NO. 00

DATE: 16.06.2022

Tag No..... Quantity.....

Data Sheet No. PES-145-06-DS2-1

DATA SHEET C

DATA SHEET – C FOR CONTROL VALVE (WITH PNEUMATIC ACTUATOR)
(TO BE FILLED BY THE BIDDER AFTER THE AWARD OF CONTRACT)

GENERAL*	PROJECT	
	SERVICE	
	LOCATION	
	DUTY	
	PIPE SIZE (inlet / outlet)	
	PIPE MATERIAL (inlet / outlet)	
BODY	MODEL NUMBER	
	TYPE OF BODY : GUIDING : NO. OF PORTS	
	BODY SIZE : PORT SIZE : DESIGN CV	
	END CONNECTION & RATING (ANSI)	
	BODY MATERIAL	
	PACKING MATERIAL SINGLE / DOUBLE	
	BONNET TYPE	
	TRIM FORM	
	TRIM MATERIAL : SEAT PLUG	
	TRIM MATERIAL : CAGE GUIDE	
	FLOW	
	OUTLET VELOCITY	
	REQUIRED LEAKAGE CLASS	
	NOISE LEVEL (dBA)	
	VACUUM SERVICE	
ANTI CAVITATION TRIM		
PNEUMATIC ACTUATOR	MODEL NO. & SIZE	
	CLOSE AT : OPEN AT (Kg / Cm ² g)	
	*TRAVEL TIME FOR OPEN TO CLOSE, CLOSE TO OPEN	
	*VALVE POSN. ON SIGNAL AIR FAILURE	
	*VALVE POSN. ON SUPPLY AIR FAILURE	
ACCESSORIES	POSITIONER(SMART)	
	AIR FILTER REGULATOR	
	AIR LOCK RELAY	
	POSITION LIMIT SWITCH	
	POSITION TRANSMITTER	
	SOLENOID VALVE	
	E / P CONVERTER	
	JUNCTION BOX	
	HAND WHEEL (SIDE MOUNTED)	
	LOCAL POSITION INDICATOR	

FORM NO. PEM-5666-0



Sagardighi Thermal Power Project

1 x 660 MW Unit No. 5, Phase-III

Technical specification for
Control Valve with Accessories - Feed Control Valve
 (Pneumatically Operated)

SPEC NO.: **PE-TS-445-145-I801A**

DOCUMENT NO.

VOLUME II B

SECTION C

ISSUE NO. 2

REV. NO. 00

DATE: 16.06.2022

Tag No..... Quantity.....				Data Sheet No. PES-145-06-DS2-1					
DATA SHEET C									
DATA SHEET – C FOR CONTROL VALVE (WITH PNEUMATIC ACTUATOR) (TO BE FILLED BY THE BIDDER AFTER THE AWARD OF CONTRACT)									
PERFORMANCE OF VALVE	HYSTERSIS								
	LINEARITY								
	SENSITIVITY								
	ACCURACY (Overall)								
SERVICE CONDITION*	SL.+ NO.	LOAD	FLOW (T/HR)	INLET PR. (KG/CM² (A))	OUTLET PR. (KG/CM² (A))	TEMP DEG. C	CALCULATED CV	% VALVE LIFT	VALVE O/L VELOCITY
VALVE TYPE									
* MAX SHUT OFF PRESS ((KG/CM ² g)									
* BODY DESIGN : PRESS ((KG/CM ² g) TEMP (DEG. C)									
* IBR FORM III-C									
TOTAL WEIGHT (VALVE + ACTUATOR + ACCESSORIES) KG.									
SEA WORTHY PACKING APPLICABLE / NOT APPLICABLE									

FORM NO. PEM-5666-0



Sagardighi Thermal Power Project

1 x 660 MW Unit No. 5, Phase-III

Technical specification for Control Valve with Accessories - Feed Control Valve (Pneumatically Operated)

SPEC NO.: PE-TS-445-145-I801A	
DOCUMENT NO.	
VOLUME	II B
SECTION	C
ISSUE NO.	2
REV. NO. 00	DATE: 16.06.2022

Tag No..... Quantity.....

Data Sheet No. PES-145-06-DS2-1

DATA SHEET C FOR ACCESSORIES

**DATA SHEET – C FOR CONTROL VALVE (WITH PNEUMATIC ACTUATOR)
(TO BE FILLED BY THE BIDDER AFTER THE AWARD OF CONTRACT)**

POSITIONER	MFR. & MODEL NUMBER	
	BYPASS	ENCL. CLASS
	INPUT SIGNAL (Kg / Cm ²)	
	OUTPUT SIGNAL (Kg / Cm ²)	
AIR FILTER REGULATOR	MFR. & MODEL NUMBER	
	AIR SUPPLY PRESS (Kg / Cm ² g)	
	OUTPUT PRESS (Kg / Cm ² g)	
	OUTPUT GAUGE	
	FILTER SIZE	
	AUTO DRAIN FEATURE	
AIR LOCK	MFR. & MODEL NUMBER	
	SET PRESS (Kg / Cm ²)	
	SUPPLY PRESS (Kg / Cm ²)	
	RESET TYPE	
	VENT PLUG	
LIMIT SWITCH	MFR. & MODEL NUMBER	
	OPEN posn	CLOSE posn
	CONTACT TYPE	
	RATING (AC / DC)	
	ENCLOSURE CLASS	
POSITION TRANSMITTER	MFR. & MODEL NUMBER	
	TYPE	
	SUPPLY	
	OUTPUT RATING	
	ACCURACY	
	ENCLOSURE CLASS	
SOLENOID VALVE	MFR. & MODEL NUMBER	
	RATING	
	OPERATION	QUANTITY
	COIL INSULATION CLASS	
	ENCLOSURE CLASS	
HANDWHEEL	ORIENTATION	
JUNCTION BOX	NO. OF WAYS	
	SIZE	
	CABLE GLANDS (Size / Quantity)	
	ENCLOSURE CLASS	
	BODY MATERIAL	
I/P CONVERTER	INPUT SIGNAL	POWER SUPPLY
	SPLIT RANGE	
	ENCLOSURE CLASS	
	LINEARITY	
	HYSTERESIS	
Cu./SS Tubing & Fittings / per CV	15 Meters of 1/4" PVC coated SS Tubing, with 1 set of Fittings for each CV for connection to IA Header on one end and accessories on another end of CV.	
PAINTING	COLOUR/SHADE	
	THICKNESS (DFT)	
	TYPE	
		COMPANY SEAL
		NAME
		SIGNATURE
		DATE

915507/2022/PS-PEM-C_I

FORM NO. PEM-6666-0



Sagardighi Thermal Power Project

1 x 660 MW Unit No. 5, Phase-III

Technical specification for
Control Valve with Accessories - Feed Control Valve
 (Pneumatically Operated)

SPEC NO.: PE-TS-445-145-I801A

DOCUMENT NO.

VOLUME II B

SECTION C

ISSUE NO. 2

REV. NO. 00

DATE: 16.06.2022

SECTION-C

QUALITY PLAN



PEM :: C&I

QUALITY PLAN FOR CONTROL VALVE (PNEUMATIC)

QUALITY PLAN NO.: **PE-QP-445-145-I 006**
 VOLUME IIB
 SECTION D
 REV. NO. 03 DATE: 02.06.2022
 SHEET 1 OF 7

Sl. No.	Component / operation	Characteristics Checked	* Category	Type/Method of Check	Extent of Check	Reference documents	Acceptance Norms	Format of Records	Agency \$			Remarks	
									P	W	V		
1.0	MATERIAL												
1.1	Body & Bonnet casting / forgings, plug, valve stem, seat ring/cage	1. Physical, Chemical properties 2. Heat Treatment	MA	Physical, Chemical tests Review of H.T. Chart	One/ Heat(HT Batch) Each H.T.	Approved drg. / data sheet Approved drg. / data sheet	Approved drg./ data sheet Approved drg. / data sheet	Test Certificate Test Certificate	3 3/2	---	2 2	2,1,4 1,4	TC for body/ bonnet from foundry only 1.IBR Certification (if applicable) to be verified by BHEL. 2.Applicable for body/bonnet only
		3. Internal quality of castings	MA	RT for Body & UT for Bonnet	100%	ASME B 16.34	ASME B 16.34	Test Report / FILM	3/2	2	2	1,4	Applicable for Body and Bonnet for rating ANSI 900 and above.
		4. Surface Quality	MA	1. Visual	100%	ANSI/ MSS-SP-55	ANSI/ MSS-SP-55	Test Certificate	3/2	---	2	2,4	
				2. MT/PT	100%	ASME B 16.34	ASME B 16.34	Test Certificate	3	2	2	1,4	After Machining on machined surface only
		5. Pressure test for shell	MA	Hyd. Test	100%	ISA-S-75.19/ ASME B 16.34	ISA-S-75.19/ ASME B 16.34	Test Certificate	2	2	2	1,4	For Body & Bonnet after machining

LEGEND:
 * CR - Critical characteristics
 MA - Major characteristics
 MI - Minor characteristics
 \$ P - Agency Performing the Test.
 W - Agency Witnessing the Test.
 V - Agency Verifying the Test.
 PT - Dye penetrant Test
 MT- Magnetic Test
 RT- Radiographic Test
 UT - Ultrasonic Test

1 - BHEL
 2 - Vendor
 3 - Sub-vendor
 4 - WBPDCI /WBPDCI TPIA



PEM :: C&I

QUALITY PLAN FOR CONTROL VALVE (PNEUMATIC)

QUALITY PLAN NO.: PE-QP-445-145-I 006
 VOLUME IIB
 SECTION D
 REV. NO. 03 DATE: 02.06.2022
 SHEET 2 OF 7

Sl. No.	Component / operation	Characteristics Checked	* Category	Type/Method of Check	Extent of Check	Reference documents	Acceptance Norms	Format of Records	Agency \$			Remarks
									P	W	V	
1.2	Diaphragm	1. Surface Quality	MA	Visual	100%	Mfr. standard	Mfr. standard	Test Certificate	3/2	---	2.4	2.4
		2. Hardness	MA	Measurement	100%	Mfr. standard	Mfr. standard	Test Certificate	3/2	---	2.4	2.4
		3. Endurance / Life cycle	MA	Cyclic test 10,000 cycles	One / Type	10,000 cycles/ Mfr. standard.	No damage	Test Certificate	3/2	---	2.1, 4	2.1, 4
1.3	Spring	1. Composition	MA	Chemical-Analysis	One sample/ Heat	Material spec. / Mfr. standard	Material spec. / Mfr. standard	Test Certificate	3	---	2.4	2.4
		2. Mech. Properties	MA	Mech. Test	One sample/ Heat	Material spec. / Mfr. standard	Material spec. / Mfr. standard	Test Certificate	3	---	2.4	2.4
		3. Performance	MA	1. Stiffness ratio 2. Scragging 3. Cyclic test (Endurance) 4. Dimension (Measurement)	100%	Material spec. / Mfr. standard	Material spec. / Mfr. standard	Test Certificate	3	---	2.4	2.4

LEGEND:
 * CR - Critical characteristics
 MA - Major characteristics
 MI - Minor characteristics
 \$ P - Agency Performing the Test.
 W - Agency Witnessing the Test.
 V - Agency Verifying the Test.
 RT- Radiographic Test
 UT - Ultrasonic Test
 PT - Dye penetrant Test
 MT- Magnetic Test

1 - BHEL
 2 - Vendor
 3 - Sub-vendor
 4 - WBPDCI
 /WBPDCI TPIA



**QUALITY PLAN
FOR
CONTROL VALVE (PNEUMATIC)**

QUALITY PLAN NO.: **PE-QP-445-145-I 006**
 VOLUME IIB
 SECTION D
 REV. NO. 03 DATE: 02.06.2022
 SHEET 3 OF 7

Sl. No.	Component / operation	Characteristics Checked	* Category	Type/Method of Check	Extent of Check	Reference documents	Acceptance Norms	Format of Records	Agency \$			Remarks
									P	W	V	
1.4	Electrical items [Limit switches, Solenoids, Position Transmitter(if provided externally)]	1. Routine Test	MA	HV, IR, Continuity function	100%	Relevant Standards	Relevant Standards	Test Certificate	3	---	2,4	Certificate of Conformance (C.O.C)
		2. Degree of protection	MA	IP/NEMA Tests	One sample / type	Approved Data sheet	Approved Data sheet	Test Certificate	3	---	2,1, 4	C.O.C
1.5	Pressure Gauges (if provided externally)	1. Performance	MA	Review of calibration certificates	100%	Mfr. Standard	Mfr. Standard	Test Certificate	3	---	2,4	C.O.C
		2. Marking	MA	Visual	100%	Mfr. standard	Mfr. standard	Test Certificate	3	---	2,4	C.O.C
2.0 IN PROCESS INSPECTION												
2.1	After machining, i. Body ii. Bonnet iii. Plug iv. Valve Stem v. seat ring/cage	1. Surface flaws	MA	Visual & MT/PT	100% (on accessible surfaces)	ASME B 16.34	ASME B 16.34	Test Records	2	---	1,4	Butt weld ends shall be included.
		2. Dimensional checks	MA	Measurement	100%	Mfr. Standard	Mfr. Standard	Records	2	---	1,4	
		3. Hard facing (wherever applicable)	MA	Hardness Measurement	One sample/Lot	Mfr. Standard	Mfr. Standard	Records	2	---	1,4	
3.0 TESTS ON COMPLETED VALVE												
3.1	Actuator Chamber	Leakage & Strength	MA	Pneumatic test	100%	Mfr. Standard	No Leakage	Test Certificate	2	1,4	1,4	Refer Note-4
3.2	Body	Leakage and Pressure test (Body Mount Leakage)	MA	Hydro test	100%	ISA - S-75.19/ASME B46.34	No Leakage	Test Certificate	2	1,4	1,4	Refer Note-4

LEGEND:
 * CR - Critical characteristics
 MA - Major characteristics
 MI - Minor characteristics
 RT- Radiographic Test
 UT - Ultrasonic Test
 PT - Dye penetrant Test
 MT- Magnetic Test
 \$ P - Agency Performing the Test.
 W - Agency Witnessing the Test.
 V - Agency Verifying the Test.
 1 - BHEL
 2 - Vendor
 3 - Sub-vendor
 4 - WBPDCI /WBPDCI TPIA



PEM :: C&I

QUALITY PLAN FOR CONTROL VALVE (PNEUMATIC)

QUALITY PLAN NO.: **PE-QP-445-145-I 006**
 VOLUME IIB
 SECTION D
 REV. NO. 03 DATE: 02.06.2022
 SHEET 5 OF 7

Sl. No.	Component / operation	Characteristics Checked	* Category	Type/Method of Check	Extent of Check	Reference documents	Acceptance Norms	Format of Records	Agency \$			Remarks
									P	W	V	
9.	Operation of limit switch & solenoids and other accessories	MA	Function	100%	Mfr. Procedure	Approved drg. / data sheet	2	Test Report	1,4	1,4	1,4	On assembled valve Refer Note-4
10.	Overall dimensions	MI	Visual and dimensional	100%	Approved drg. / data sheet	Approved drg. / data sheet	2	Records	1,4	1,4	1,4	Refer Note-4
11.	Pre defined valve position in case of air failure	MA	Visual	100%	Approved drg. / data sheet	Approved drg. / data sheet	2	Test Certificate	1,4	1,4	1,4	1
12.	Cleanliness, painting, stamping (for direction of flow), Tag No.	MA	Visual and dimensional, paint thickness	100%	Mfr. Procedure	Approved drg. / data sheet	2	Test Certificate	1,4	1,4	1,4	
13.	Surface Quality	MA	Visual	100%	ANSI/ MSS-SP-55	ANSI/ MSS-SP-55	3/2	Test Certificate	--	--	2,1,4	

5.0 AUXILIARY ITEMS (Performance test of auxiliary items shall be performed on the completely assembled valve)

5.1	Positioner	Overall leakage after assembly including Nozzles leakage	MA	Leak Test (in the steady state input signal)	100 %	Mfr. Standard	No leakage	Test Certificate	---	---	1,4	Certificate of Conformance (C.O.C)
5.2	Air filter regulator	1. Normal air consumption	MA	Measurement	Each type	Mfr. Standard	No leakage	Test Certificate	---	---	1,4	(C.O.C)
		2. Overall leakage	MA	Visual (soap solution)	100 %	Mfr. Standard	No leakage	Test Certificate	---	---	1,4	(C.O.C)

LEGEND:
 * CR - Critical characteristics
 MA - Major characteristics
 MI - Minor characteristics
 RT- Radiographic Test
 UT - Ultrasonic Test
 PT - Dye penetrant Test
 MT- Magnetic Test

\$ P - Agency Performing the Test.
 W - Agency Witnessing the Test.
 V - Agency Verifying the Test.
 1 - BHEL
 2 - Vendor
 3 - Sub-vendor

4 - WBPDCCL /WBPDCCL TPIA



PEM :: C&I

QUALITY PLAN FOR CONTROL VALVE (PNEUMATIC)

QUALITY PLAN NO.: **PE-QP-445-145-I 006**
 VOLUME IIB
 SECTION D
 REV. NO. 03 DATE: 02.06.2022
 SHEET 6 OF 7

Sl. No.	Component / operation	Characteristics Checked	* Category	Type/Method of Check	Extent of Check	Reference documents	Acceptance Norms	Format of Records	Agency \$			Remarks
									P	W	V	
5.3	Air lock relay	Performance Test	MA	Leakage test	100%	Mfr. Standard	No leakage	Test Certificate 02	3/2	---	1,4 02	(C.O.C)
5.4	Electronic position transmitter(not applicable if provided integral to smart positioner)	1. Accuracy	MA	Operation	100%	Approved data sheet /	Approved data sheet /	Test Certificate 02	2	1	1,4 02	(C.O.C)
5.5	Current to Pneumatic converter(not applicable for smart positioner)	1. Physical Verification Make/Model	MA	Visual	100%	Approved drg. / data sheet	Approved drg. / data sheet	Test Certificate 02	2	---	1,4 02	(C.O.C)
		2. Degree of Protection	MA	IP/NEMA test	Each type	Relevant Standard	Relevant Standard	Test Certificate 02	3	---	1,4 02	(C.O.C)
		3. Linearity	CR	Measurement	100%	Approved drg. / data sheet /	Approved drg. / data sheet /	Test Certificate 02	2	---	1,4 02	(C.O.C)
5.6	Smart Positioner (As Applicable)	4. Hysteresis	CR	Measurement	100%	Approved drg. / data sheet /	Approved drg. / data sheet /	Test Certificate 02	2	---	1,4 02	(C.O.C)
		1. Physical Verification Make/Model	MA	Visual	100%	Approved drg. / data sheet	Approved drg. / data sheet	Test Certificate 02	2	---	1,4 02	(C.O.C)
		2. Degree of Protection	MA	IP/NEMA test	Each type	Relevant Standard	Relevant Standard	Test Certificate 02	3	---	---	02

LEGEND:
 * CR - Critical characteristics
 MA - Major characteristics
 MI - Minor characteristics
 RT- Radiographic Test
 UT - Ultrasonic Test
 PT - Dye penetrant Test
 MT- Magnetic Test

\$ P - Agency Performing the Test.
 W - Agency Witnessing the Test.
 V - Agency Verifying the Test.

1 - BHEL
 2 - Vendor
 3 - Sub-vendor

4 - WBPDCCL
 /WBPDCCL TPIA
 02

 PEM :: C&I	QUALITY PLAN FOR CONTROL VALVE (PNEUMATIC)	QUALITY PLAN NO.: PE-QP-445-145-I 006	VOLUME IIB
			SECTION D
		REV. NO. 03	DATE: 02.06.2022
		SHEET 7	OF 7

Sl. No.	Component / operation	Characteristics Checked	* Category	Type/Method of Check	Extent of Check	Reference documents	Acceptance Norms	Format of Records	Agency \$			Remarks
									P	W	V	
		3. Linearity	CR	Measurement	100%	Approved drg. / data sheet /	Approved drg. / data sheet /	Test Certificate	2	---	1,4	(C.O.C)
		4. Hysteresis	CR	Measurement	100%	Approved drg. / data sheet /	Approved drg. / data sheet /	Test Certificate	2	---	1,4	(C.O.C)
		5. Calibration with Hand Held Communicator	MA	Measurement	Each type	Mfr. Standard	Mfr. Standard	Test Certificate	2	---	1,4	(C.O.C)
6.0	PAINTING	Soundness of Painting	MA	Visual and Measurement	100%	Mfr. Standard	Mfr. Standard	Inspection Report	2	---	1	Refer Note-2
7.0	PACKING	Soundness of Packing against transit damage	MA	Visual	100%	Mfr. Standard	Mfr. Standard	Inspection Report	2	-	1	Refer Note-3

NOTES:

1. In case valid CV test certificate for a similar control valve (same size, same CV, same trim characteristics) is not submitted to BHEL by the vendor, CV test shall be conducted at FCRI/Any govt. approved laboratory.
2. In the absence of BHEL spec. for painting, vendor to obtain BHEL's approval on their painting specification / procedure.
3. Sea worthy packing shall be provided, if called for in the Data sheets.
4. The quantum of check shall be 100% for manufacturer and 10% or 1 no. for each type, size and model no. for BHEL/BHEL nominated inspection agency/ WBPDCCL/ WBPDCCL TPIA.
5. IBR certificates in Form III-C shall be submitted if called for in the specification/datasheet.
6. Copies of all TC's (Test Certificates) for materials duly correlated with Heat Nos., TC's for electrical items and mechanical tests (Leak/Operation), C.O.C's (Certificates of Conformance) shall be submitted to BHEL for verification and acceptance.

LEGEND: * CR - Critical characteristics MA - Major characteristics MI - Minor characteristics	RT- Radiographic Test UT - Ultrasonic Test	PT - Dye penetrant Test MT- Magnetic Test	\$ P - Agency Performing the Test. W - Agency Witnessing the Test. V - Agency Verifying the Test.	1 - BHEL 2 - Vendor 3 - Sub-vendor	4 - WBPDCCL /WBPDCCL TPIA
---	---	--	---	--	---------------------------

915507/2022/PS-PEM-C I

FORM NO. PEM-6666-0



Sagardighi Thermal Power Project

1 x 660 MW Unit No. 5, Phase-III

Technical specification for
Control Valve with Accessories - Feed Control Valve
(Pneumatically Operated)

SPEC NO.: PE-TS-445-145-I801A

DOCUMENT NO.

VOLUME II B

SECTION C

ISSUE NO. 2

REV. NO. 00

DATE: 16.06.2022

SECTION – C

BILL OF QUANTITY-MAIN SUPPLY

915507/2022/PS-PEM-C I

FORM NO. PEM-6666-0



Sagardighi Thermal Power Project

1 x 660 MW Unit No. 5, Phase-III

Technical specification for
Control Valve with Accessories - Feed Control Valve
(Pneumatically Operated)

SPEC NO.: PE-TS-445-145-I801A

DOCUMENT NO.

VOLUME II B

SECTION C

ISSUE NO. 2

REV. NO. 00

DATE: 16.06.2022

BILL OF QUANTITY-MAIN SUPPLY

[A] CONTROL VALVES COMPLETE WITH POSITIONER AND ALL ACCESSORIES MOUNTED, TUBED AND TERMINATED ON JB

[A]	MAIN SUPPLY		
S.NO.	TAG NO	DESCRIPTION	TOTAL QTY.
1	FDV-14	LOW LOAD FEED CONTROL VALVE	1 NO.
[B]	1/4 " SS TUBING (25 METER FOR EACH TAG)		25 METER
[C]	SS FITTINGS- FOR EACH TAG		
1		SS FITTINGS for connection to Air Filter Regulator- FOR EACH TAG	1 LOT
2		SS FITTINGS for connection to Air Lock Relay- FOR EACH TAG	1 LOT
3		SS FITTINGS for connection to IA Header Isolation Valve - FOR EACH TAG	1 LOT
4		SS EQUAL TEE - FOR EACH TAG	1 LOT
5		SS 1/2 " NPT(M) X 1/4 " OD TUBE CONNECTOR- FOR EACH TAG	1 LOT
[D]	VALVE DIAGNOSTIC AND CONFIGURATION SOFTWARE (FOR ALL TAGS)		1 LOT
[E]	CV TEST CHARGE		1 NO.

915507/2022/PS-PEM-C_I

FORM NO. PEM-6666-0



Sagardighi Thermal Power Project

1 x 660 MW Unit No. 5, Phase-III

Technical specification for
Control Valve with Accessories - Feed Control Valve
 (Pneumatically Operated)

SPEC NO.: PE-TS-445-145-I801A

DOCUMENT NO.

VOLUME II B

SECTION C

ISSUE NO. 2

REV. NO. 00

DATE: 16.06.2022

SECTION – C

BILL OF QUANTITY-SPARES



Sagardighi Thermal Power Project

1 x 660 MW Unit No. 5, Phase-III

Technical specification for
Control Valve with Accessories - Feed Control Valve
(Pneumatically Operated)

SPEC NO.: PE-TS-445-145-I801A

DOCUMENT NO.

VOLUME II B

SECTION C

ISSUE NO. 2

REV. NO. 00

DATE: 16.06.2022

LIST OF COMMISSIONING SPARES

S.NO.	ITEM DESCRIPTION	QUANTITY PER UNIT
1	Gaskets	One(1) set with each control valve tag
2	Gland Packing	One(1) set with each control valve tag

LIST OF MANDATORY SPARES

S.NO.	ITEM DESCRIPTION	QUANTITY PER UNIT
1	Bonnet Seal	2Set (one set means complete replacement required for one Valve)
2	Gland Packing	3Set (one set means complete replacement required for one Valve)
3	Plug, Seat, Cage, Stem etc.	1Set (one set means complete replacement required for one Valve)
4	Retainer Ring, Seal Ring etc.	1Set (one set means complete replacement required for one Valve)
5	Actuator Seal Kit for Pneumatic Cylinder	2Nos.
6	Smart Positioner of the Valve	1No.
7	Position Feedback Transmitter (applicable if it is not integral with the Smart Positioner)	1No.

NOTE

- Wherever quantity has been specified as percentage (%), the quantity of mandatory spares to be provided by contractor shall be the specified percentage (%) of the total population of the plant. In case the quantity so calculated happens to be a fraction, the same shall be rounded off to next higher whole number.
- Wherever the quantities have been indicated for each type, size, thickness, material, radius, range etc., these shall cover all the items supplied and installed and the breakup for these shall be furnished in the bid. In case spares indicated in the list are not applicable to the particular design offered by the bidder, the bidder should offer spares applicable to offered design with quantities generally in line with the approach followed in the above list.



Sagardighi Thermal Power Project

1 x 660 MW Unit No. 5, Phase-III

Technical specification for
Control Valve with Accessories - Feed Control Valve
(Pneumatically Operated)

SPEC NO.: PE-TS-445-145-I801A

DOCUMENT NO.

VOLUME II B

SECTION D

ISSUE NO. 2

REV. NO. 00

DATE: 16.06.2022

SECTION – D

- **EQUIPMENT SPECIFICATION
(PES-145-06)**
- **SPECIFICATION FOR SMART POSITIONER
(PES-145-06A)**
 - **HOOK-UP DIAGRAM (PES-145-06B)**
 - **GUIDELINES FOR PACKING (PES-145-06C)**
 - **SUB-VENDOR LIST**



Sagardighi Thermal Power Project

1 x 660 MW Unit No. 5, Phase-III

Technical specification for
Control Valve with Accessories - Feed Control Valve
(Pneumatically Operated)

SPEC NO.: PE-TS-445-145-I801A

DOCUMENT NO.

VOLUME II B

SECTION

ISSUE NO. 2

REV. NO. 00

DATE: 16.06.2022

SECTION – D

EQUIPMENT SPECIFICATION (PES-145-06)

	SPECIFICATION FOR CONTROL VALVE (WITH PNEUMATIC / ELECTRIC ACTUATOR)		SPECIFICATION NO.: PE-TS-XXX-145-I104		
			DOCUMENT NO.: PES – 145 - 06		
			VOLUME	II B	
			SECTION	D	
			ISSUE NO.	2	
			REV. NO.	01	DATE : 16.03.2019
			SHEET	29	OF 51

1.0 SCOPE

- 1.1 This specification covers the Design, Manufacture, Inspection and Testing at the manufacturer's works, proper packing for transportation and delivery to site of Control valve (with Pneumatic/Electric Actuator as identified in the datasheet-A) for use in Utility/Captive Power Station/Combined Cycle Station.
- 1.2 Expander/Reducer between valve body & pipe shall be in BHEL's scope of supply. However, any other expander/reducer required shall be in bidder's scope of supply.

2.0 CODES AND STANDARDS

- 2.1 As a minimum requirement, the latest revision/version of the following (or equivalent) standards shall be complied as a minimum requirement :-

Indian Boiler Regulation (IBR)	
Allowable Seat leakage	: FCI-70.2
Pressure & Temperature ratings	: ANSI-B16.34
Enclosure class	: IEC-144 / NEMA / IS-13947
Control Valves Sizing	: ISA S-75
Electric Motor operated Actuators	: IS-9334

3.0 TECHNICAL REQUIREMENTS

The Control valve, Actuator and the accessories shall be suitable for continuous operation under an ambient temperature of 0-60°C and Relative Humidity of 0-95% unless specified otherwise in volume IIB Section-B or Section-C.

3.1 Control Valve

The control valve shall be suitably designed for the process operating conditions and system characteristics as specified in the Data Sheet-A.

- 3.1.1 The control valve shall be of globe/angle body design, as per datasheet, with single port. Valve trim shall be cage guided balanced type for valve sizes $\geq 3"$ and above. The valve trim shall be suitable for quick replacement without any cutting or welding. Anti-cavitation trims shall be provided for valves with cavitation service and hardened trims for flashing services.
- 3.1.2 The trim material and body material has been specified in the Datasheet-A. Bidder to offer body material and trim material combination as per the datasheet. Wherever there is a deviation from the datasheets, bidder to furnish the documentary proof for confirming superior trim material/body material selection along with their offer. BHEL/Customer reserves the right to accept/reject any variation in the specification.
- 3.1.3 Not used
- 3.1.4 Asbestos shall not be used for the packing or any other component.

	SPECIFICATION FOR CONTROL VALVE (WITH PNEUMATIC / ELECTRIC ACTUATOR)	SPECIFICATION NO.: PE-TS-XXX-145-I104		
		DOCUMENT NO.: PES – 145 - 06		
		VOLUME	II B	
		SECTION	D	
		ISSUE NO.	2	
		REV. NO.	01	DATE : 16.03.2019
		SHEET	30	OF 51

- 3.1.5 The valve bonnet and packing shall be suitable for the service conditions as in Data Sheet-A. Gland sealed type bonnets are not acceptable. Double packing is mandatory for applications involving vacuum service. For valves where downstream is subjected to vacuum, flow action shall be "flow to close" (over the seat). Bonnets having Teflon packing shall have valve stem finished to 2-4 microns. Packing material requiring lubrication will not be acceptable.
- Type of bonnet shall be according to the service condition. Extension bonnets shall be provided when the maximum temperature of the flowing fluid is greater than 280 or unless otherwise specified. Cast Steel (CS) yokes shall be offered for CEP Minimum Recirculation valve/GSC minimum recirculation control valve. Cast Iron (CI) yokes are not acceptable for this service.
- 3.1.6 The valve end connection as specified in Data Sheet-A shall conform to ANSI B16.25 for Butt Weld connection, ANSI B16.11 for Socket Weld connection and ANSI B16.5 for flanged ends. Tolerances on end to end, center to center, center to face shall be in accordance with ASME B16.10. The end connections shall be Socket Welded for sizes up to 50 NB and Butt Welded for sizes above 50 NB.
- 3.1.7 The valve seat leakage shall be as per FCI-70.2. The leakage class shall be as per Data Sheet-A.
- 3.1.8 The valve body shall have the direction of flow embossed on all valves.
- 3.1.9 The sizing shall conform to the requirements of ISA S75.01, and the valve capacity shall be selected so as to meet the following:
- | | | | | |
|--|---|---|---|--------------------|
| Valve with Linear Characteristic | - | Normal Flow (Design Point) | : | 70-75% valve lift. |
| | - | Max. Flow | : | 90% valve lift. |
| | - | Min. Flow | : | >10% valve lift. |
| Valve with Equipercentage Characteristic | - | Normal Flow (Design Point) | : | 75-85% valve lift. |
| | - | Max. Flow | : | 90% valve lift. |
| | - | Min. Flow | : | >10% valve lift. |
| ON/OFF Quick open Characteristic | - | 1.1 times the CV calculated on the basis of maximum flow condition. | | |
- The valve offered shall be capable of handling 120 % of the required maximum flow.
- 3.1.10 Calculation for valve sizing, velocity and noise shall be subject to purchaser's approval during contract stage. However responsibility of proper selection and design for the duties specified lies with the vendor. Any modifications required to be done on the valves or actuators & accessories to achieve satisfactory performance of the control system shall be done without any commercial & delivery implication.
- 3.1.11 The valve outlet velocities shall be limited to the following values, unless otherwise specified in the Data sheet-A.
- | | | | |
|------|------------------|----|--|
| i) | Liquid service | <= | 8 m/sec |
| ii) | Steam service | <= | 150 m/sec |
| iii) | Flashing service | <= | 50% of sonic velocity for flashing services. |
- 3.1.12 For flashing duty, trim design shall be such that the vapour bubbles are kept away from valve body.
- 3.1.13 For cavitation service, the trim design shall be of multistage pressure drop type, so as to avoid cavitation altogether, instead of keeping cavitation away from valve parts.

	SPECIFICATION FOR CONTROL VALVE (WITH PNEUMATIC / ELECTRIC ACTUATOR)	SPECIFICATION NO.: PE-TS-XXX-145-I104		
		DOCUMENT NO.: PES – 145 - 06		
		VOLUME	II B	
		SECTION	D	
		ISSUE NO.	2	
		REV. NO.	01	DATE : 16.03.2019
		SHEET	31	OF 51

- 3.1.14 The equivalent weighted sound level measured at 1.5 metre above floor level in elevation and 1 metre horizontally from the control valve expressed in decibels to a reference of 0.0002 microbar shall not exceed 85 dBA (without pipe insulation). The offer shall include noise prediction calculations for each valve.
- 3.1.15 In case of predicted noise level above 85 dBA, same shall be brought down to acceptable noise level i.e. below 85 dBA through Source treatment (proper valve trim & valve body selection). Path treatment (LNP/ Diffuser/ Cartridge/ Silencer etc.), if any shall be subject to Customer's/Owner's approval.
- 3.1.16 In case of wrong selection/mal operation of valve and for associated actuator during guarantee period, the vendor shall replace the valve suitably with a modified/new valve of design as approved by purchaser and all the expenses for replacement, rectification/modification including transportation both ways will be at vendor's expenses.
- 3.2 **ACTUATORS-** The control valves shall be operated either pneumatically (with pneumatic actuator) or electrically (with electric actuator).
For pneumatic actuator, clause nos. 3.2.1 through 3.2.6 to be followed.
- 3.2.1 **Pneumatic Actuator**
- The actuator shall be designed for a thrust of 120% of valve's shut-off pressure at an airline supply pressure of 5 Kg/Sq. cm.
- The pneumatic actuators shall be employed for modulating or open/close duty, as specified in Data Sheet-A. The bidder shall be responsible for proper selection and sizing of valve actuators in accordance with the pressure drops, shut off pressure and valve travel.
- The pneumatic spring opposed diaphragm actuator or piston actuator as the case may be for modulating duty shall be capable of positioning the associated valve at desired opening for all the operating conditions specified.
- 3.2.2 The pneumatic actuator for open/close duty shall be suitable for fast opening/closing of the associated valve.
- 3.2.3 The actuator design shall allow valve assembly to be mounted at 45° inclination on either side in the vertical plane.
- 3.2.4 The actuators shall be suitably sized to ensure that the associated valve travel time from full open to full closed position and vice versa is less than 10 seconds or as specified in the datasheet under the most stringent service conditions.
- 3.2.5 The actuator's hand wheel shall have OPEN & CLOSE direction marking and clockwise rotation as viewed from front shall close the valve.
- 3.2.6 Each actuator shall be provided with a mechanical pointer attached to stem, moving over a graduated scale with markings, for OPEN, 25%, 50%, 75%, CLOSE positions.

	SPECIFICATION FOR CONTROL VALVE (WITH PNEUMATIC / ELECTRIC ACTUATOR)	SPECIFICATION NO.: PE-TS-XXX-145-I104		
		DOCUMENT NO.: PES – 145 - 06		
		VOLUME	II B	
		SECTION	D	
		ISSUE NO.	2	
		REV. NO.	01	DATE : 16.03.2019
		SHEET	32	OF 51

3.3 Accessories for Control valve with Pneumatic Actuator

The bidder shall offer all the accessories as specified in the Data Sheet - A for the Pneumatic Actuators under modulating or OPEN/CLOSE duty. The accessories specified shall be supplied duly mounted on the valve actuator and piped with PVC covered copper/ SS tube and flare-less brass/ SS fittings etc. as per the hook up diagram (Refer drawing no. PES-145

3.4 **Painting** of the control valve assembly shall be as per the Painting Specification attached elsewhere in this technical specification. In the absence of specification for painting, vendor to submit their standard painting procedure for painting for BHEL's approval. Epoxy based paint (corrosion-resistant) to be provided for control valves for coastal environment.

3.5 Sub-vendor list –

The sub-vendors shall be as per the list enclosed elsewhere in this specification. In case the bidder proposes sub-vendors other than those listed in the specification, the same shall be subject to BHEL's/Customer's approval.

4.0 TESTING AND INSPECTION

4.1 The testing and inspection of the equipment/items shall be in line with the approved QAP

4.2 The cost of all tests as per the approved QAP will be deemed to have been included in the bid.

4.3 In case, the bidder is supplying the valve from outside India, the third party inspection shall be arranged and considered by the bidder in their offer.

5.0 SPARES AND CONSUMABLES

5.1 Start-up/Commissioning Spares

The bidder shall supply all the start-up/commissioning spares as per the BOQ given in the technical specification.

5.2 Mandatory Spares

The bidder shall supply all the mandatory spares as per the BOQ given in the technical specification.

6.0 DRAWINGS AND DOCUMENTS

6.1 The bidder shall furnish the following documents along with the bid: 4 Sets

6.1.1 Data sheet-B, completely filled-up along with all enclosures.

~~6.1.2 Schedule of prices in attached format (VOL. III).~~

6.1.3 Quality Plan duly signed & stamped.

6.1.4 All relevant Catalogs with detailed technical information.

	SPECIFICATION FOR CONTROL VALVE (WITH PNEUMATIC / ELECTRIC ACTUATOR)		SPECIFICATION NO.: PE-TS-XXX-145-I104		
			DOCUMENT NO.: PES – 145 - 06		
			VOLUME	II B	
			SECTION	D	
			ISSUE NO.	2	
			REV. NO.	01	DATE : 16.03.2019
			SHEET	33	OF 51

6.2 **The successful bidder shall furnish the following documents to BHEL during the contract stage viz. after the award of contract:**

5 sets of the following documents for approval + 2 sets of CDs:

6.2.1 CONTROL VALVE DOCUMENTS (Drg. No. PE-VO-XXX-145-I004) including the following:-

- (a) Assembly (dimensional) drawings.
- (b) Valve Edge preparation details.
- (c) Data sheet-C completely filled-up.
- (d) Hook-up diagram of Control Valve with Actuator & Accessories.
- (e) Valve & Actuator assembly dimensional drawings with weights.
- (f) All calculations like CV, Noise Level, Valve Outlet Velocity, Actuator sizing etc.
- (g) All relevant catalogues for models of the valves as well as accessories finalized.

6.2.2 QUALITY PLAN (Drg. No. PE-QP-XXX-145-I006) duly signed and stamped.

6.3 **Final documentation:**

Documents / drawings to be furnished by the successful bidder shall be as follows:
15 sets with 6 CD-ROMS of:-

6.3.1 Category I & IV approved CONTROL VALVE DOCUMENTS

6.3.2 Test certificates

6.3.3 Operation & maintenance manuals for Control Valve, Actuator and all accessories

7.0 MARKING AND PACKING

7.1 **Marking**

A stainless steel metal nameplate should be permanently fixed on each equipment giving its tag number and technical specifications.

7.2 **Packing**

All equipment / materials shall be suitably packed and protected for the entire period of dispatch, storage and erection against impact, abrasion, corrosion, incidental damage due to vermin, sunlight, high temperature, rain, moisture, humidity, dust, sea water spray (where applicable) as well as rough handling and delays in transit and storage in open. Guidelines for packing are enclosed (Refer specification no. PES-145-06C).

8.0 APPLICABLE DATA SHEET FORMS

This document shall be read with one or more of the following data sheet forms:

- Data sheet A&B for Control Valve with Pneumatic Actuator : Data sheet no. PES-145-06-DS1-1
- Data sheet C for Control Valve with Pneumatic Actuator : Data sheet no. PES-145-06-DS2-1

915507/2022/PS-PEM-C_I

FORM NO. PEM-6666-0



Sagardighi Thermal Power Project

1 x 660 MW Unit No. 5, Phase-III

Technical specification for
Control Valve with Accessories - Feed Control Valve
(Pneumatically Operated)

SPEC NO.: PE-TS-445-145-I801A

DOCUMENT NO.

VOLUME II B

SECTION D

ISSUE NO. 2

REV. NO. 00

DATE: 16.06.2022

SECTION-D

SPECIFICATION FOR SMART POSITIONER (PES-145-06A)

	SPECIFICATIONS FOR MICROPROCESSOR BASED ELECTRONIC POSITIONER (SMART)	SPECIFICATION NO.: PE-TS-XXX-145-I104	
		DOCUMENT NO.: PES-145-06A	
		VOLUME. II B	
		SECTION D	
		ISSUE NO. 2, REV.01	DATE : 16.03.19
SHEET 35 OF 51			

1.0 Electrical

Input Signal	4-20mA
Power Supply	Loop Powered from the output card of Control System (12-30 V DC)
Hart Protocol	Compatibility For Remote Calibration & Diagnostic (Super-Imposed HART Signal On Input Signal (4-20mA)
Valve Position Feedback (4-20mA)	Position Sensing 4-20mA O/P Signal For Control System To Be Provided. If non contact type of Position feedback signal is required, Position transmitter to be separately provided.

2.0 Environment

Operating Temperature	0 To 60 Deg C
Humidity	0-95%
Protection Class	IP-65 (Minimum)

3.0 Software For Configuration & Diagnostic

Software	Windows Based Software, Software Shall Meet The Requirement For Configuration, Diagnostics, Calibration And Testing Of the Actuator. Valve positioning timing, actuator leakage, and Valve Wear & tear, fault alarm to be offered as a minimum. Easily up gradable with same hardware and compatible with any HART management systems / AMS.
Diagnostic/Test Features (Optional)	Advanced Diagnostic Features Like Stroke On Line Partial Closure Test, Valve Signature Analysis (Online graphical representation), Step Response Test, Valve Friction/Jamming Detection Etc To Be Provided.

	SPECIFICATIONS FOR MICROPROCESSOR BASED ELECTRONIC POSITIONER (SMART)	SPECIFICATION NO.: PE-TS-XXX-145-1104	
		DOCUMENT NO.: PES-145-06A	
		VOLUME. II B	
		SECTION D	
		ISSUE NO. 2 , REV.01	DATE : 16.03.19
		SHEET	36 OF 51

Factory Valve Signature Tests Reports (Pr Vs Valve Travel And Travel Vs I/P Signal) Are To Be Provided.

Hardware PC For Configuration/Software (OPTIONAL)

Test Certificates Test Certificates As Per Manufacture Standard/Relevant Standard Are To Be Submitted.

Configuration / Remote Calibration, Auto & Manual Calibration Shall Be Possible.

4.0 Modes

Valve Action	Direct & Reverse, Valve Action. (Same positioner for Single Acting or Double Acting And no separate relays required for changing from Single acting to double).
Flow Characterization	Possible to fit valve characteristic curve linear & Equal percentage
Fail Safe/Fail Freeze (Optional)	Fail Safe/Fail Freeze feature is to be provided.

5.0 Performance

Characteristic Deviation	<=0.75% of span
Ambient temp effect	<=0.01%/Deg C or better.
Dead Band	Adjustable 0.1 to 10%.
Scan Time	10ms
Resolution	<=0.05%
Sensitivity/Linearity	0.3-0.4% of FS
Repeatability	0.32% of FS
Auto-Tune	Yes

	SPECIFICATIONS FOR MICROPROCESSOR BASED ELECTRONIC POSITIONER (SMART)	SPECIFICATION NO.: PE-TS-XXX-145-I104	
		DOCUMENT NO.: PES-145-06A	
		VOLUME. II B	
		SECTION D	
		ISSUE NO. 2 , REV.01	DATE : 16.03.19
SHEET 37 OF 51			

Leak Test Yes

7.0 EMC & CE compliance

Required International Standard Like EN/IEC. To En50081-2&En50082 or equivalent

8.0 Accessories

In Built Operator Panel Display With Push Buttons For Configuration And Display On The Positioner Itself

Hand Held Hart Calibrator (Optional) Universal Hart Calibrator To Be Provided, One Per Unit.

Press Gauge Block For Supply & Output Pr., Filter Regulator Other Accessories Shall Be Provided As On Required Basis For Making System Complete.

Electrical cable entry $\frac{1}{2}$ -Npt, side or bottom entry to avoid water Ingress.

915507/2022/PS-PEM-C_I

FORM NO. PEM-6666-0



Sagardighi Thermal Power Project

1 x 660 MW Unit No. 5, Phase-III

Technical specification for
Control Valve with Accessories - Feed Control Valve
 (Pneumatically Operated)

SPEC NO.: PE-TS-445-145-I801A

DOCUMENT NO.

VOLUME II B

SECTION D

ISSUE NO. 2

REV. NO. 00

DATE: 16.06.2022

SECTION-D

HOOK-UP DIAGRAM (PES-145-06B)

BHEL PEM	DATA SHEET FOR CONTROL VALVES (WITH PNEUMATIC ACTUATOR)	SPECIFICATION NO.: PE-TS-445-145-1104	
		VOLUME	
		SECTION	
		REV. NO. 03	DATE : 17.05.2022
		SHEET 62	OF 62

STANDARD CONTROL VALVE HOOK-UP DIAGRAM (DOUBLE ACTING PISTON ACTUATOR WITH SMART POSITIONER)

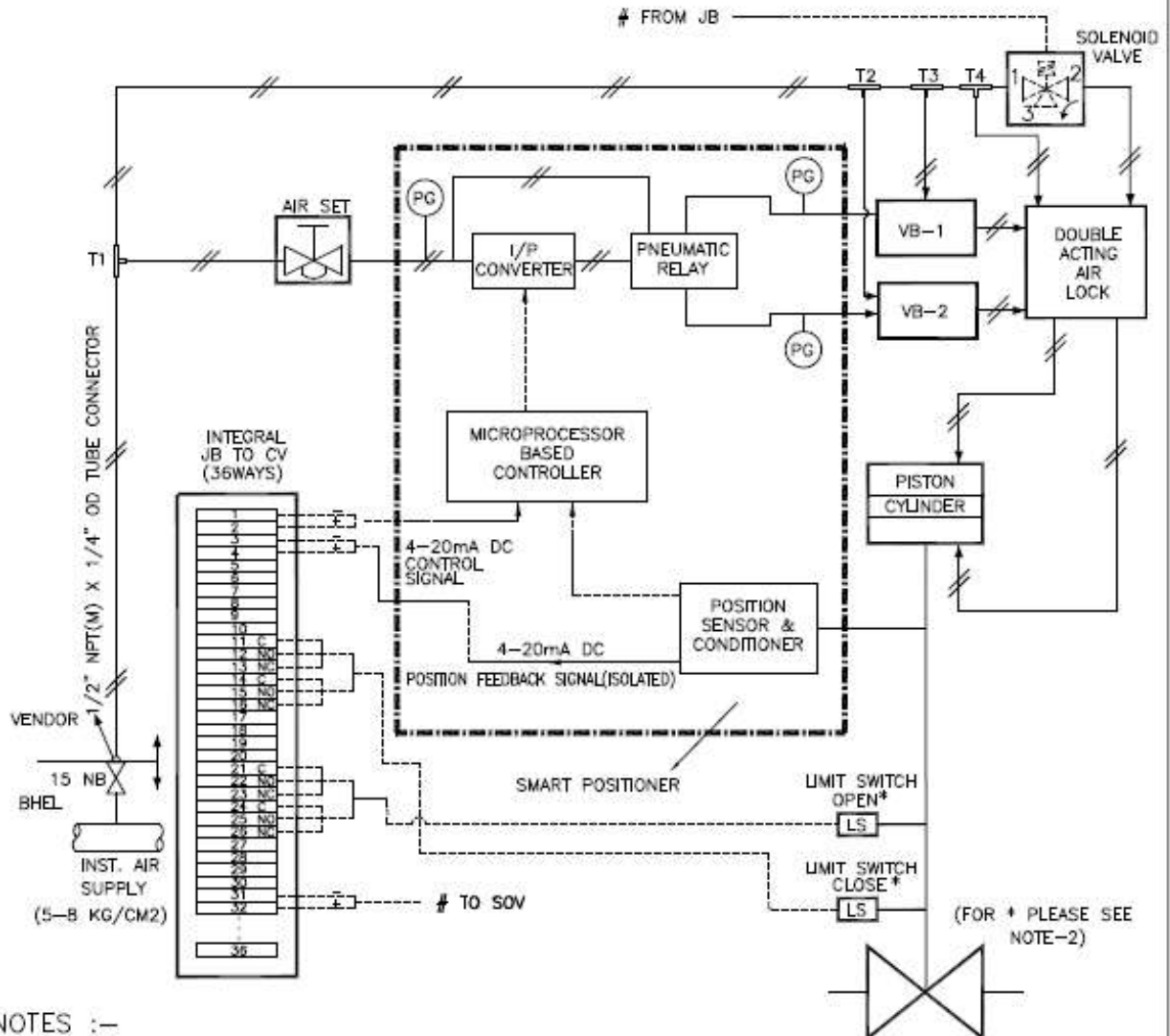

NOTES :-

1. POSITION OF EACH VALVE ON SUPPLY AIR FAILURE / ELECTRICAL SIGNAL FAILURE SHALL BE AS PER SPECIFICATION/DATA SHEET-A. AIR LOCK SHALL BE PROVIDED ACCORDINGLY.
2. SOLENOID VALVE & LIMIT SWITCHES WILL BE PROVIDED ONLY FOR CONTROL VALVES IF INDICATED IN RESPECTIVE DATA SHEETS.
3. SOLENOID VALVES PORTS CONDITION:
PORT 1 AND 2 SHALL BE CONNECTED UNDER DE-ENERGISED CONDITION.
PORT 2 AND 3 SHALL BE CONNECTED UNDER ENERGISED CONDITION.
4. PRESSURE GAUGES REQUIRED FOR AIR SUPPLY & OUTPUT(S).
5. MOUNTING ACCESSORIES AS REQUIRED.
6. POSITION FEEDBACK SIGNAL SHALL BE 2 WIRE 4-20mA ISOLATED SIGNAL.
7. JB TERMINALS SHALL BE CAGE CLAMP TYPE SUITABLE FOR 2.5 SQ. MM COPPER WIRE. EXTERNAL CONNECTION, OF PLUG IN TYPE OR THROUGH CABLE GLAND, SHALL BE AS PER ACCESSORY DATA SHEET.
8. ALL APPLICABLE ACCESSORIES SHALL BE PROVIDED AS INDICATED IN THE INDIVIDUAL CONTROL VALVE DATA SHEET / ACCESSORIES DATA SHEET.
9. 12 METERS 1/4" PVC COATED COPPER / SS TUBING (AS PER ACCESSORIES DATA SHEET) & 1 SET OF FITTINGS TO BE SUPPLIED FOR EACH CONTROL VALVE FOR CONNECTION TO ISOLATION VALVE AT INST AIR HEADER ON ONE END AND TO AIR LOCK RELAY/AIR FILTER REGULATOR ON THE OTHER END. ALL THE BRASS / SS FITTINGS SHALL BE DOUBLE COMPRESSION TYPE.
10. VOLUME BOOSTER (ALONG WITH TEE-T2 AND RELATED TUBING & CONNECTORS) SHALL BE PROVIDED IF REQUIRED. AIR CONNECTION TO VOLUME BOOSTER FROM TEE-T2 & TEE-T3 SHALL BE PROVIDED.

915507/2022/PS-PEM-C_I

FORM NO. PEM-6666-0



Sagardighi Thermal Power Project

1 x 660 MW Unit No. 5, Phase-III

Technical specification for
Control Valve with Accessories - Feed Control Valve
(Pneumatically Operated)

SPEC NO.: PE-TS-445-145-I801A

DOCUMENT NO.

VOLUME II B

SECTION D

ISSUE NO. 2

REV. NO. 00

DATE: 16.06.2022

SECTION-D

GUIDELINES FOR PACKING (PES-145-06C)



Technical specification for
Control Valves with Accessories
(Pneumatically Operated)

SPEC NO.: PE-TS-XXX-145-I104

DOCUMENT NO.: PES-145-06C

VOLUME II B

SECTION D

ISSUE NO. 2, REV. 01 DATE 16.03.19

SHEET 45 OF 51

Guidelines for Packing

- ✓ After inspection of control valves assembly. Smart Positioner along with Pressure Gauge shall be disassembled & packed separately.
- ✓ Threaded connection of Smart Positioner & Pressure Gauge shall be shipped with the end caps fitted to avoid any damage.
- ✓ Instructions with sketch for mounting the Smart Positioner & Pressure Gauge shall be sent along with the aforesaid accessories.
- ✓ Packing of the control valves and Smart Positioner along with Pressure Gauge shall be done in separate wooden boxes/cases in order to avoid damage during transit and also during storage at site in tropical climatic conditions for a period of 18-24 months.
- ✓ All valves & smart positioner along with pressure gauges shall be packed properly with quality wooden planks with proper wooden frame support. Moreover the valves are internally covered with polythene sheets to protect from the water and moisture entry.
- ✓ Stronger shock absorbing cover material like expanded Polyurethane which can take any direct impact on it shall be used for packing
- ✓ Proper reaper support to be provided in the packing and Valve assembly to be aligned properly to avoid the damage of accessories during transit due to vibration effect.
- ✓ Marking for Fragile & Condensing environment shall be done on the packing box.



The Following Details are to be marked on the Packing Cases

- ✓ Address of consignee
- ✓ Purchase order no.
- ✓ Description of items or title of packing list
- ✓ Weight
- ✓ Dimension of the Box
- ✓ Marking showing upright position
- ✓ Marking showing sling position
- ✓ Marking showing umbrella
(i.e. for machines/components to be stored under covered storage)

	<p align="center">Sagardighi Thermal Power Project 1 x 660 MW Unit No. 5, Phase-III</p> <p align="center">Technical specification for Control Valve with Accessories - Feed Control Valve (Pneumatically Operated)</p>	SPEC NO.: PE-TS-445-145-I801A	
		DOCUMENT NO.	
		VOLUME	II B
		SECTION	D
		ISSUE NO.	2
REV. NO. 00	DATE: 16.06.2022		

SECTION-D

SUB-VENDOR LIST



Sagardighi Thermal Power Project

1 x 660 MW Unit No. 5, Phase-III

Technical specification for
Control Valve with Accessories - Feed Control Valve
(Pneumatically Operated)

SPEC NO.: PE-TS-445-145-I801A

DOCUMENT NO.

VOLUME II B

SECTION D

ISSUE NO. 2

REV. NO. 00

DATE: 16.06.2022

SUB VENDOR LIST

(FOR ACCESSORIES)

SI. No.	ITEM DESCRIPTION	SUB-VENDORS
1.	SMART POSITIONER	ABB MASOLENIEN SIEMENS SAMR YOKOGAWA EMERSON (FISHER ROSEMOUNT) METSO YAMALKE MOORE
2.	AIR FILTER REGULATOR	FAIR CHILD, USA SHAVO NORGEN, MUMBAI SMC PNEUMATICS, NOIDA EMERSON(ASCO) CHENNAI FESTO, BANGALORE PLAKA,CHENNAI
3.	SOLENOID VALVE	ROTEX, VARODARA AVCON MUMBAI HERION, GERMANY IMI NORGEN, GERMANY JAFFERSON, ARGENTNA ASCO, CHENNAI/USA FESTO, BANGALORE SMC PNEUMATICS ,NOIDA
4.	JUNCTION BOX	SUMIP COMPOSITES, AHEMDABAD KEMROK VARODARA AJMERA, MUMBAI TRINITY TOUCH, PALWAL

11	Air Filter Regulator [Either from OEM/Authorised Source]	Parker Hannifin, Lebanon	Approved
		SHAVO NORGREN(INDIA)PVT LTD, BANGALORE	Approved
		JRU INSTRUMENTS (Formerly PLACKA)	Approved

13	SOLENOID VALVE	ASCO (I) LTD.	Approved
		ROTEX AUTOMATION LTD.	Approved
		NUCON INDUSTRIES PVT LTD	Approved
		IMI NORGREN HERION PVT. LTD.	Approved

77	Junction Box (Metal)	CHEMIN CONTROLS AND INSTRUMENTATION,PONDICHERRY	Approved
		ELECTRO MECHANICAL (INDIA),KOLKATA	Approved
		K.S.INSTRUMENTS PVT LTD,BANGALORE	Approved
		KHODAY CONTROL SYSTEMS PVT. LTD, BANGALORE	Approved
		MANISHA COMPOSITEK PVT. LTD.,PUNE	Approved
		PRAMMEN INDUSTRIES,PUDUKKOTTAI	Approved
		PYROTECH ELECTRONICS (P) LTD.,UDAIPUR	Approved

ANNEXURE I
1 X 660 MW WBPDCS SAGARDIGHI EXTN UNIT V

GeM BID NO. -----, Dt:- --

Letter head of Company

Ref.....

Date.....

To,
Bharat Heavy Electricals Limited
PEM, PPEI Building, Plot No 25,
Sector -16A, Noida (U.P)-201301

Subject: - Certification regarding local content

Dear Sir,

We hereby certify that items offered by us of Chemical Dosing System for **1 X 660 MW WBPDCS SAGARDIGHI EXTN UNIT V** meets the requirement of minimum local content in line with clause no. -- of NIT and the Public Procurement (Preference to Make in India), Order 2017 dated-15.06.2017, 28.05.2018, 29.05.2019, 04.06.2020 & 16.09.2020. The Percentage (%) of Local content is%.

We further confirm that details of location at which the local value addition is made will be our registered works at(address of the works)

Yours very truly

..... (authorized signatory of company)

..... (firm name)

authorized signatory
of company

1 X 660 MW WBPDCS SAGARDIGHI EXTN UNIT V

GeM BID NO. -....., Dt:-

ANNEXURE -II (INSTRUCTIONS TO PACKING LIST)

For faster verification of bills, successful bidder to submit detailed Bill of Material (BOM) at the time of drawings/ documents submission after placement of PO. Each item of the BOM to be uniquely identified with item code no. or item Sl. No. Supplier to ensure that all items which will find separate mention in the packing list are covered in this detailed BOM.

Supplier to also give the following undertaking in the BOM:

“The BOM provided herewith completes the scope (in content and intent) of material supply under PO No. Dated Any additional material which may become necessary for the intended application of the supplied items/package will be supplied free of cost in most reasonable time.

Packing List must indicate:

- a) Packing size
- b) Gross weight and net weight of each package
- c) Contents of the package with cross reference to BOM item code no. / Sl. No.
- d) Quantity of each items separately.

The packing list must cover all the BOM items.

Supplier to give following undertaking in the packing list:

The Packing list provided herewith is as per BOM approved under PO No. ----

ANNEXURE III
1 X 660 MW WBPDC SAGARDIGHI EXTN UNIT V

GeM BID NO. -....., Dt:-

Letter head of Company

Ref.....

Date.....

To,
Bharat Heavy Electricals Limited
PEM, PPEI Building, Plot No 25,
Sector -16A, Noida (U.P)-201301

Subject: - Certification regarding Land Border

Dear Sir,

I have read the clause regarding restrictions of procurement from a bidder of a country which shares a land border with India. I hereby certify that M/s (Organization name) is not from such a country and is eligible to be considered.

Note :- Bidder is requested to furnish the above undertaking on company letterhead from the highest competent authority at your end (i.e Owner, partner, CMD, Director, company secretariat etc.).

Yours very truly

..... (authorized signatory of company)

..... (firm name)

authorized signatory
of company