



1832359/2023/HEP-MNX35400

 BHEL Tenders		Government eProcurement System Tender Details	
		Date : 14-Dec-2023 12:04 PM	
		 Print	
Basic Details			
Organisation Chain	Bharat Heavy Electricals Limited HEP - Bhopal Transportation 354 - Material MGT-Tract. Machines		
Tender Reference Number	E5133136 Rate Contract for SHORT CIRCUIT RING		
Tender ID	2023_BHEL_31193_1	Withdrawal Allowed	Yes
Tender Type	Open Tender	Form of contract	Supply
Tender Category	Goods	No. of Covers	2
General Technical Evaluation Allowed	No	ItemWise Technical Evaluation Allowed	Yes
Payment Mode	Not Applicable	Is Multi Currency Allowed For BOQ	No
Is Multi Currency Allowed For Fee	No	Allow Two Stage Bidding	No
Cover Details, No. Of Covers - 2			
Cover No	Cover	Document Type	Description
1	Fee/PreQual/Technical	.pdf	SINED COPY OF NIT
		.pdf	SIGNED COPY OF REQUIRED DOCUMENTS AGAINST TECHNICAL PQR
		.pdf	DULY FILLED ANNEXURE-IX
		.pdf	UDYAM REGISTRATION CERTIFICATE FOR MSE BIDDER
		.pdf	DULY FILLED FORMAT FOR TECHNOCOMMERCIAL ANNEXURE
		.pdf	SIGNED COPY OF BHEL GTC BP200102A
		.pdf	SELF CERTIFICATION REGARDING MINIMUM LOCAL CONTENT
		.pdf	SIGNED COPY OF PVC Annexure
		.pdf	DULY SIGNED INTEGRITY PACT
2	Finance	.xls	PRICE BOQ
Tender Fee Details, [Total Fee in ₹ * - 0.00]		EMD Fee Details	
Tender Fee in ₹	0.00	EMD Amount in ₹	0.00
Fee Payable To	Nil	EMD through BG/ST or EMD Exemption Allowed	No
Fee Payable At	Nil	EMD Fee Type	fixed
Tender Fee Exemption Allowed	No	EMD Percentage	NA
		EMD Payable To	Nil
		EMD Payable At	Nil
Click to view modification history			
Work /Item(s)			

1832359/2023/HEP-MNX35400

Title	E5133136 RATE CONTRACT FOR SHORT CIRCUIT RING				
Work Description	E5133136 RATE CONTRACT FOR SHORT CIRCUIT RING				
Pre Qualification Details	Please refer Tender documents.				
Independent External Monitor/Remarks	AS PER ATTACHED INTEGRITY PACT				
Show Tender Value in Public Domain	No				
Tender Value in ₹	3,75,00,000	Product Category	Electrical Work/ Equipment	Sub category	NA
Contract Type	Rate Contract	Bid Validity(Days)	90	Period Of Work (Days)	730
Location	BHEL BHOPAL	Pincode	462022	Pre Bid Meeting Place	NA
Pre Bid Meeting Address	NA	Pre Bid Meeting Date	NA	Bid Opening Place	BHEL, BHOPAL
Should Allow NDA Tender	No	Allow Preferential Bidder	No		

Critical Dates

Publish Date	14-Dec-2023 05:00 PM	Bid Opening Date	05-Jan-2024 05:45 PM
Document Download / Sale Start Date	14-Dec-2023 05:15 PM	Document Download / Sale End Date	05-Jan-2024 05:30 PM
Clarification Start Date	NA	Clarification End Date	NA
Bid Submission Start Date	14-Dec-2023 05:30 PM	Bid Submission End Date	05-Jan-2024 05:30 PM

Tender Documents

NIT Document	S.No	Document Name	Description	Document Size (in KB)
	1	Tendernotice_1.pdf	NIT	670.01

Work Item Documents	S.No	Document Type	Document Name	Description	Document Size (in KB)
	1	Tender Documents	NIT.pdf	NIT	653.61
	2	Tender Documents	PQR.pdf	PQR	568.42
	3	Tender Documents	QAP_DRG_SPEC.pdf	QAP DRG SPEC	1730.96
	4	Tender Documents	PVCAnnexure.pdf	PVC Annexure	721.40
	5	Tender Documents	MII_Certificate.pdf	MII CERTIFICATE	181.84
	6	Tender Documents	3GTC_BP200102A.pdf	GTC BP 200102A	723.99
	7	Tender Documents	4PO_Terms.pdf	PO TERMS CONDITIONS	926.57
	8	Tender Documents	5ANNEX_IX.pdf	ANNEXURE IX	395.92
	9	Tender Documents	6PPP_for_more_than_5_lacs.pdf	6PPP_for_more_than_5_lacs.pdf	6643.24
	10	Tender Documents	Integrity_Pact.pdf	INTEGRITY PACT	1670.58
	11	Tender Documents	Enquiry_E5133136.pdf	E5133136	1003.46
	12	BOQ	BOQ_32591.xls	PRICE BOQ	344.00

Bid Openers List

S.No	Bid Opener Login Id	Bid Opener Name	Certificate Name
1.	dpandey@bhel.in	DEEPENDRA PANDEY	Deependra pandey
2.	gauravkatiyar@bhel.in	GAURAV KUMAR KATIYAR	GAURAV KUMAR KATIYAR
3.	ranjana1@bhel.in	RANJANA PARTE	Ranjana Parte
4.	srishti1@bhel.in	SRISHTI TIRKEY	Srishti Tirkey

GeMARPTS Details

--	--

1832359/2023/HEP-MNX35400

GeM ARPT'S ID	CXXFP3CBHSXA		
Description	SHORT CIRCUIT RING		
Report Initiated On	12-Dec-2023		
Valid Until	11-Jan-2024		

Tender Properties			
Auto Tendering Process allowed	No	Show Technical bid status	Yes
Show Finance bid status	Yes	Show Bids Details	No
BoQ Comparative Chart model	Normal	BoQ Compative chart decimal places	3
BoQ Comparative Chart Rank Type	L	Form Based BoQ	No
Show Bid Details in Public Domain stage	Technical Bid Opening		

TIA Undertaking			
S.No	Undertaking to Order	Tender complying with Order	Reason for non compliance of Order
1	PPP-MII Order 2017	Agree	MII APPLICABLE
2	MSEs Order 2012	Agree	MSE APPLICABLE

Tender Inviting Authority	
Name	DEEPENDRA PANDEY
Address	BHEL BHOPAL

Tender Creator Details	
Created By	DEEPENDRA PANDEY
Designation	Dy Manager
Created Date	14-Dec-2023 11:10 AM

Tender No.		E5133136		
Description :		<p>RATE CONTRACT FOR SHORT CIRCUIT RING DE & NDE AS PER DRG NO.34454505051 REV.02. (QAP NO:- QAP/ QTM/ VENDOR QAP/ 2022-23/ SHORT CIRCUIT (SC) RING REV 00 DTD 10/03/2023).</p> <p>TENDER QTY.: 2048 NOS, +/- 30%</p> <p>Rate Contract is proposed to be finalized on two sources. Preferred cumulative delivery shall be within 90 days for 1st lot of 128 Nos (Cumulative refers to quantity from both vendors i.e. 83 Nos and 45 Nos from L-1 vendor and vendor accepting L-1 price respectively OR entire 128 Nos from single vendor as per respective proportion of quantity allotted) FROM DATE OF PLACEMENT OF PO, THEREAFTER EACH SUBSEQUENT LOT OF 256 Nos (Cumulative refers to quantity from both vendors i.e. 166 Nos and 90 Nos from L-1 vendor and vendor accepting L-1 price respectively OR entire 256 Nos from single vendor as per respective proportion of quantity allotted) WITHIN NEXT 60 DAYS FROM EARLIER LOT.</p>		
Sr. No.	ELEMENTS	Standards	To be offered/confirmed by supplier	Remarks, if any
1	Quotation reference no. & date	As per supplier		
2	HSN / SAC code	As per supplier		
3	Quotation currency	In INR		
4	Contact person	As per supplier		
5	Phone / Mobile	As per supplier		
6	E-Mail	As per supplier		
7	Order to be placed on (Also provide supplier code at BHEL Bhopal, If registered)	As per supplier		
8	Address	As per supplier		
9	Please specify delivery in weeks/ days (Specify item wise, lot wise as per RFQ)	As per NIT/ Accepted with deviation (If select Accepted with deviation, please mention the deviation)		
10	PVC applicable and PVC annexure attached {Bidder have to quote only firm fabrication rate is Rs per NO in Price BOQ (In NIC tender)}.	Yes		
11	Quoted for all the items of tender enquiry	Yes / No. (If "No" please mention item number of regreted items)		
12	Technical specifications	Accepted as per NIT / Accepted with deviation (If select Accepted with deviation, please mention the deviation)		
13	Inspection	As per NIT/ Accepted with deviation (If select Accepted with deviation, please mention the deviation)		
14	Test certificate & Gurantee certificate as per NIT, Drawings and specification will be submitted along with each consignment	Yes (In case of "No" your offer may be rejected).		
15	Brand name, if any.	As per supplier		
16	Supply from	As per supplier		
17	Terms of delivery ("FOR DESTINATION " means freight & insurance upto destination in supplier's scope (Destination: CRX Divn, BHEL Bhopal)	Accepted/ Accepted with deviation (If select Accepted with deviation, please mention the deviation)		
18	Transit insurance (In supplier's scope)	As per NIT/ Accepted with deviation (If select Accepted with deviation, please mention the deviation)		
19	CGST RATE (IN %)	As per supplier		
20	SGST RATE (IN %)	As per supplier		
21	IGST RATE (IN %)	As per supplier		
22	UGST RATE (IN %)	As per supplier		
23	Are you manufacturer of quoted item (s).	Yes / No		
24	Are you registered under MSMED ACT 2006 as small or micro. NOTE: - Firms registered under medium scale shall not be considered eligible for MSE benefits.	Yes / No (If select Yes, please enclosed valid UDYAM certificate)		

Tender No.		E5133136		
Description :		<p>RATE CONTRACT FOR SHORT CIRCUIT RING DE & NDE AS PER DRG NO.34454505051 REV.02. (QAP NO:- QAP/ QTM/ VENDOR QAP/ 2022-23/ SHORT CIRCUIT (SC) RING REV 00 DTD 10/03/2023).</p> <p>TENDER QTY.: 2048 NOS, +/- 30%</p> <p>Rate Contract is proposed to be finalized on two sources. Preferred cumulative delivery shall be within 90 days for 1st lot of 128 Nos (Cumulative refers to quantity from both vendors i.e. 83 Nos and 45 Nos from L-1 vendor and vendor accepting L-1 price respectively OR entire 128 Nos from single vendor as per respective proportion of quantity allotted) FROM DATE OF PLACEMENT OF PO, THEREAFTER EACH SUBSEQUENT LOT OF 256 Nos (Cumulative refers to quantity from both vendors i.e. 166 Nos and 90 Nos from L-1 vendor and vendor accepting L-1 price respectively OR entire 256 Nos from single vendor as per respective proportion of quantity allotted) WITHIN NEXT 60 DAYS FROM EARLIER LOT.</p>		
Sr. No.	ELEMENTS	Standards	To be offered/confirmed by supplier	Remarks, if any
25	Terms of Payment (100% payment in 90 days of receipt (45 days for MSE including Udyam registered suppliers as per relevant act in force), subject to acceptance of material and relevant documents at BHEL. Pl refer GTC BP200102A)	As per NIT/ Accepted with deviation (If select Accepted with deviation, please mention the deviation)		
26	SELF CERTIFICATION OF MINIMUM LOCAL CONTENT, IF MORE THAN 50% VALUE ADDITION IS IN INDIA. (Note- In case of tenders worth more than Rs. 10 crores, Suppliers shall necessarily submit certificate from statutory auditor or cost auditor or cost accountant or CA) Please also specify the amount of local content in India. EXAMPLE :if 100% INDIGENOUS (MADE IN INDIA) MARK "Y"/100%	As per supplier		
27	Details of location of value addition / manufacturing	As per supplier		
28	Other Charges (If any)	Applicable / Not Applicable. (If applicable please mention percentage (%) / Value (along with type of charges).		
29	Penalty for delayed performance as per BP200102A	Yes / No (In case of "No", your offer will be loaded suitably)		
30	Confirmation that documents pertaining to technical PQR & Financial PQR has been submitted	Yes / No		
31	Acceptance to "REVERSE AUCTION" if conducted (As per BHEL's RA policy)	Yes / No		
32	Submission of Declaration format with duly sealed & signed (Annexure IX, refer attached) regarding whether other family firms or sister concern affiliates / subsidiary firms are participating in the same tender.	(Yes / No) if No please specify the reason.		
33	General terms and conditions of enquiry (Form No. BP-200102A) and BHEL PO Terms & Conditions is Acceptable.	Yes (In case of "No" your offer may be rejected).		
34	Quotation Validity will be 90 days from the date of techno-commercial bid opening.	Yes		
35	Tender fees submitted	Yes / Not Applicable	Not Applicable	



BP 200102A

GENERAL TERMS AND CONDITIONS OF ENQUIRY

Sl.No.	Description
1	General:
A	These General terms & conditions (GTC) shall apply to all enquiries, notice inviting tenders, request for quotations concerning the supply of goods and / or rendering of services to Bharat Heavy Electricals Ltd., Bhopal (hereinafter referred to as BHEL or the Purchaser) or its Projects / Customers. Special / supplementary enquiry conditions, if any, will override the conditions in this annexure.
2	General Instructions - Common for Indigenous & Foreign enquiries
A	Through E- procurement
A1	<p>1. Offer shall be submitted by the bidders in single/two parts as called in Tender enquiry. Bid Part - I Technical cum Commercial bid Bid Part - II Price bid</p> <p>2. Suppliers shall quote price on BHEL authorised third party service provider e-procurement site. Any deviation from the price format shall be clearly brought out in the offer Bid Part I.</p> <p>The offer shall be uploaded on BHEL e-procurement site using Class III digital signature. All documents to be uploaded are necessarily to be signed and stamped. The quotation should be uploaded on the site before due date and time. Part-I of the bid shall contain complete item-wise scope of supply as offered vis-à-vis the scope of supply as per enquiry, all commercial terms and conditions etc. It is expected that bidders shall meet all our technical and commercial requirements and shall not deviate from them.</p>
B	Through tender room
B1	<p>Sealed bids are invited for scope of Supply / Services as detailed in the enquiry. Bid should be free from correction, overwriting, using of corrective fluid etc. Any interlineation, cutting, overwriting shall be valid only if they are attested under full signature(s) of persons signing the bid else shall be liable for rejection. All overwriting/ cutting etc. will be numbered by bid opening officials and announced during bid opening. The bid should be submitted in English or Hindi language. Relevant enclosures, supporting documents, catalogue, samples, if any, as required as per Notice Inviting Tender (NIT) conditions shall be sent along with technical offer. Rate should be quoted in the units asked for in the enquiry.</p>
B2	<p>Bids shall be submitted in a Sealed cover with Enquiry No., Due date and Bidder's name indicated on the cover. In case of Two Part Bid, technical bid containing technical offer, this GTC duly filled-in & signed; and un-priced copy of the Price Bid should be kept in one envelope. Price Bid containing only the price (as called for in the price format where required) should be kept in a separate envelope. Both envelopes indicating Part —I or Part-II as the case may be to be put in a bigger envelope, which should be addressed to in charge, Tender Room, Bharat Heavy Electricals Ltd. 2nd Floor, Jawahar Bhavan, Piplani, Bhopal 462022. Enquiry No., due date and bidder's name must be mentioned on all envelopes. Offer must reach tender room of BHEL Bhopal latest by 11.00 am IST on the enquiry due date. Bids submitted as single part bid against two – part bid, shall be rejected unless the offer is techno-commercially acceptable without seeking any clarification.</p>
B3	Offer received after 11.00 AM IST of the due date will be termed as "Late" and shall not be considered. However, late offer received against single tender enquiry may be considered.
B4	Bidder can also submit offer through email, if called for in the enquiry, at the email address indicated in the enquiry. Such email offers shall be sent only on designated email-id to reach before 11.00 am IST on the tender due date. BHEL will not be responsible for incomplete offers and the ones delivered late through e-mail.
C	Through tender room or EProcurement
C1	Commercial Conditions quoted by the bidder in any place including as stated in bidder's 'General Terms and Conditions' if any, shall not be binding on the Purchaser and the conditions contained in this annexure, including special conditions, if any, for this enquiry shall only prevail.
C2	Rate should be quoted in the units asked for in the enquiry. The rates should be quoted both in figures and words. In case of discrepancy in figures and words, the rates quoted in words shall be considered.
C3	The goods offered shall conform to BHEL specifications and / or National/International standards as mentioned in the Enquiry and the bidder is required to confirm his unconditional acceptance to the same. Bidders, seeking deviations from the specifications and any other conditions, may indicate the same clearly on a separate sheet indicating Sl. No. of the item, with reasons for such deviations. BHEL reserves the right to reject the offer with deviations or load the deviations suitably for evaluation.
C4	Offers shall be submitted directly by bidder or his authorized agent only. Unsolicited offers shall be summarily rejected.

 BP 200102A	<h2 style="color: #0070C0;">GENERAL TERMS AND CONDITIONS OF ENQUIRY</h2>
C5	Bid in single part or techno-commercial bid in two-part system (as the case may be) will be opened on the due date. In case of two part bid, price bids of techno-commercially accepted bidder(s) only shall be opened on the assigned date, for which separate intimation will be sent to the accepted bidders.
C6	The bidder whose bid is technically not accepted will be informed & EMD wherever submitted shall be returned along with his price bid within <i>30 days</i> of contract finalization date. No interest will be payable on EMD amount. EMD shall however be forfeited in the event of bidder opting out after submission of the bid.
C7	<ol style="list-style-type: none"> 1. Any discount / revised offer submitted by a bidder on its own shall be considered, provided it is received on or before the due date and time of offer submission (Part-I). Conditional discounts shall not be considered for evaluation of tenders. 2. Unsolicited discounts / revised offers given after Part-I bid opening shall not be accepted. No change in price will be permitted within the validity period of offer. 3. In case of changes in scope and / or technical specification and / or commercial terms & conditions, having price implication, techno-commercially acceptable bidders shall be asked by BHEL to submit the impact of such changes on their price bids. In case a bidder opts to submit revised price bid instead of impact called for, then latest price bid shall prevail. However in both situations, original price bid will be necessarily opened.
C8	The bidders will submit Integrity Pact, duly signed by its authorized signatory, where called for in the enquiry.
C9	Wherever the enquiry is issued to unregistered bidder, the bidder shall visit ' www.bhel.com ' for submitting the online Supplier Registration Application. Price bids of such bidders, will be opened only on techno-commercial acceptance of bid & after supplier registration.
C10	BHEL expects that the bidder responds to the enquiry. Regret letter, with valid reasons for not participating in the tender will be submitted where the bidder is unable to submit offer. Repeated lack of response on the part of bidder may lead to his deletion from BHEL's approved bidder list. Refer guidelines for suspension of Business Dealings with Suppliers/Contractors available on https://www.bhel.com/sites/default/files/suspension_guidelines_abridged.pdf
C11	In case of open tenders (i.e. those published in website) all corrigenda, addenda, amendments, time extensions, clarifications etc. to the tender will be hosted on BHEL website. (www.bhel.com) only. Bidders responding to these tender should regularly visit website(s) to keep themselves updated.
C12	In the course of evaluation, if more than one bidder happens to occupy L-1 status effective L-1 will be decided by soliciting discounts from the respective L-1 bidders in sealed envelope and will be open in tender room. In case more than one bidder happens to occupy the L-1 status even after soliciting discounts, the L-1 bidder shall be decided by a toss/ draw of lots, in presence of the respective L-1 bidders or their representatives. Ranking will be done accordingly. BHEL's decision in such situations shall be final and binding.
C13	The Purchaser can consider awarding tendered quantities among more than one bidder (after acceptance of L1 price by the other bidders) in the manner and proportion disclosed in the tender conditions. Purchaser can also consider awarding of part of the tendered quantity to other than L-1 bidder at L1 counter offered rates, if the quantity offered by the L-1 bidder is less than the quantity tendered for.
C14	The bidder shall submit price bid strictly in the price format, wherever provided for, in the enquiry. Any attempt on the part of the bidder to alter the contents of the price bid format in any manner, which in the opinion of BHEL can vitiate the tendering process, will lead to rejection of the bid, <i>besides BHEL taking appropriate punitive action as deemed fit.</i> Refer Guidelines for suspension of Business Dealings with Suppliers/Contractors available on https://www.bhel.com/sites/default/files/suspension_guidelines_abridged.pdf
D	BHEL shall be resorting to Reverse Auction (RA) (Guidelines as available on www.bhel.com). If tender specific conditions call for reverse auction, RA shall be conducted among the techno-commercially qualified bidders. Price bids of all techno-commercially qualified bidders shall be opened and same shall be considered for RA. In case any bidder(s) do(es) not participate in online Reverse Auction, their sealed envelope price bid along with applicable loading, if any, shall be considered for ranking
3	Delivery Terms
A	Indigenous Purchase
A1	Goods shall be delivered on 'FOR Destination' basis to the named destination unless otherwise called for in the enquiry.
B	Foreign Purchase — Imports
B1	<ol style="list-style-type: none"> 1. Goods shall be despatched by Sea, unless stated otherwise in the enquiry or purchase order. 2. Terms of Delivery for Sea shipment shall be on CFR / CIF basis with 14 days' detention free period preferably at Dry Port - ICD Mandideep (INMDD6) for FCL (Full Container Load) Cargo of GP & HC Containers. 3. For other cases - Other than GP & HC Containers, LCL Cargo shall be delivered at Nhava Sheva (JNPT- INNSA1) & Break-bulk Cargo at Mumbai (MPT - INBOM1). 4. For Air consignments, the terms of delivery shall be FCA at BHEL nominated Airport. In case of CIP, delivery shall be at Mumbai ACC (INBOM4). 5. Freight amount shall be indicated separately in the offer in case of CIP/CFR/CIF.



BP 200102A

GENERAL TERMS AND CONDITIONS OF ENQUIRY

	<p>6. The number of detention free days and destination charges payable to shipping line must be mentioned in your offer and also on the Bill of Lading.</p> <p>7. Offer received on FOB basis may be considered on an exceptional basis. BHEL will load freight, marine insurance & shipping line port handling charges etc. to work out landed cost at Sea Port.</p> <p>8. Please visit BHEL Bhopal website https://bpl.bhel.com for details of named Air ports and Sea ports. Name of the gateway port so chosen by the bidder shall be indicated by the Bidder in his offer.</p> <p>9a In case of CIP/CFR/CIF, the shipping line should be ready to move the containers to consignee's nominated CFS (Container Freight Station) yard and Indian agent of shipping line should issue Cargo Arrival Notice (CAN) 7 days in advance.</p> <p>9b In case of CFR contract, bidder to supply the material through a Certified Sea worthy vessel age not more than 15 years.</p> <p>9c The invoices being issued by shipping lines must be in the name of BHEL. Otherwise, BHEL will recover loss of Input Credit on GST from the vendor.</p> <p>9d While booking the shipment, bidder to also finalize destination charges and the same should appear over BL or agreed tariff to be provided to BHEL before arrival of shipment. If cargo is stuffed in container, then the same should be allowed to be moved to CFS of importer's choice without any additional charges.</p> <p>9e Load port charges shall be settled by the supplier and not be passed on to BHEL in any form of destination charges.</p> <p>10. For reasons of delay in receipt of documents from suppliers or due to the same being found to be incomplete, and or faulty, the suppliers shall be responsible to reimburse all penalties, detention and demurrages / wharfages, if any paid by BHEL (for stated reasons).</p>	
B2	<p>1. For delivery of FCL (Full Container Load) cargo, the Bidder shall provide minimum 14 days' detention free period from the date of delivery at Port of Discharge / Place of Delivery (in case of ICD). Wherever the detention free period offered is less than 14 days, the bids shall be loaded for the period short of 14 days' period.</p> <p>2. <u>Port Congestion charges or any additional charges claimed by the shipping line at Port of Discharge / Place of Delivery shall be to the Bidder's account.</u></p>	
4	Bidder's particulars & logistics information (Bidder to give details against each of the provisions)	
A	Name of the bidder's executive to deal with this tender / project	
B	E-mail address of the contact person	
C	Telephone no. of the contact person	
D	Name of location from where the goods shall be offered for inspection and dispatch	
5	Additional logistics information for Imports	
A	Bid currency	
B	Charges applicable at discharge port up to BHEL's CFS (Container Freight Station) to be indicated in your offer and on the B/L	
C	Name of Airport in the country of dispatch for FCA delivery terms	
D	Estimated number, type & size of containers for delivery of tendered quantity (applicable where the goods are to be sent in FCL)	
E	No. of packages with cumulative gross weight and CBM volume (applicable for LCL & Break-bulk shipment)	
F	Approx. distance in km. from Bidder's works to Port of Loading	Sea port /Air port
6	Delivery Schedule & Completion date	
A	<ul style="list-style-type: none"> • Instead of writing specific date against delivery offered, bidder shall commit delivery period in number of days / weeks/ months to suit the delivery period indicated in the enquiry. • Commencement of delivery period shall be reckoned from the date of PO / LOI or any other agreed milestone. • Bidder shall deliver the goods in the manner and schedule agreed under the Purchase order. • Goods shall be delivered within contractual period or any extension thereof, if any, granted by the Purchaser. • If delivery is linked to approval of documents, time for submission of such documents to be indicated and delivery period to be indicated from approval of documents. This delivery schedule will be considered for processing delivery extension, wherever applicable. • BHEL reserves the right to cancel the order if material is not delivered within PO scheduled delivery. 	



BP 200102A

GENERAL TERMS AND CONDITIONS OF ENQUIRY

B	In case of foreign supplies, the date of Bill of Lading (B/L) or AWB shall be taken as actual date of delivery where freight until discharge port in India is in Seller's scope like CFR/CIF/CIP delivery terms. For Ex-works/FCA/FOB or any other delivery term where freight is in buyer's scope, date of material readiness /Test certificate/ Warehouse receipt/Freight forwarder receipt may be considered as mutually agreed.
C	In case of Indigenous bidders, the date of delivery at named destination in India shall be taken as contractual delivery completion date where delivery terms are FOR destination. In case of 'Ex-works' delivery terms, the date of LR / RR shall be the contractual delivery completion date.
7	Transit Insurance
A	Except where delivery terms are agreed on CIF basis for Imports & FOR destination basis for indigenous purchases, transit insurance will be covered by BHEL under its Open Marine Transit Insurance Policy. Bidder shall inform dispatch particulars with value of consignment to the Purchaser within 07 days of dispatch for BHEL to arrange insurance coverage in its policy. Failure on the part of bidder to inform dispatch particulars will make him liable to pay for any transit damages / losses suffered by the Purchaser.
8	Force Majeure
A	Notwithstanding anything contained in the contract, neither the Bidder nor the Purchaser shall be held responsible for total or partial non-execution of any of the contractual obligations, should the obligation become unreasonably onerous or impossible due to occurrence of a 'Force Majeure' which directly affects the obligations to be performed by the Purchaser or the Bidder; Such events include war, military operations of any nature, blockages, revolutions, insurrections, riots, civil commotions, insurgency, sabotage, acts of public enemy, fires, explosion, epidemics, quarantine restrictions, floods, earthquake, or acts of God, restrictions by Govt. authorities; over which the Bidder or the Purchaser has no control. The party claiming to be affected by force majeure shall notify the other party in writing without delay, within two weeks on the intervention and on the cessation of such circumstance. Extension of time sought by the Bidder along with supporting evidence and so granted by the Purchaser for the supply/ work affected, if any, shall not be construed as waiver in respect of remaining deliveries. Rescheduling of deliveries on account of force majeure conditions, if so agreed by the Purchaser, will not entail the Bidder to claim any increase in the price on whatsoever account. Notwithstanding above provisions, Purchaser shall reserve the right to cancel the order/ Contract, wholly or partly, in order to meet the overall project schedule and make alternative arrangements. If deemed necessary, Purchaser may takeover partly processed material at a mutually agreed price.
9	Penalty for delayed performance.
A1	Subject to force majeure conditions, penalty shall be 0.5% of the total order value per week of delay or part thereof, subject a maximum of 10% of the total order value. Total order value above shall be item wise, lot wise order value. Any deviation based on specific requirement shall be specified separately in the NIT.
A2	However, in case of Capital Machine / BOP where staggered deliveries may be applicable, the penalty will be levied on total order value.
A3	In case of any amendment / revision, the penalty shall be linked to the amended / revised PO.
A4	Any loading on penalty clause shall be to the extent to which it is not agreed to by the bidder (at offered value)
B	If the material is not supplied within the agreed delivery period, BHEL reserves the right to cancel the order and purchase the material from alternate source(s) at the Risk and Cost of the Bidder. In such an event, it shall be obligatory on the part of bidder to make good any loss suffered by the purchaser.
C	In case the contractually agreed delivery date falls on a holiday in BHEL Bhopal, the next working day shall be taken as contractual delivery date for compliance and applicability of LD / penalty.
D	In case of any recovery for delayed performance, the applicable GST shall also be recoverable from bidders.
10	Indian Agents and Agency commission
A	BHEL prefers to deal directly with Foreign bidder, wherever required, for procurement of Goods. However if the Foreign Principal desires to avail services of an Indian Agent, then the Principal should ensure compliance to "regulatory guidelines" which will require submission of an agency agreement.
B	The CFR / CIF price quoted will be deemed to be inclusive of Indian Agency commission. Agency commission as disclosed by the bidder in his quoted CFR / CIF price will be paid in Indian Rupees on receipt & acceptance of Materials or it's installation at destination, as the case may be. The lower of the 'TT buying rate prevailing on the date of technical bid opening or price bid opening shall be considered for computation of Agency commission.
C	In a tender either the Indian Agent on behalf of Principal / OEM or the Principal / OEM itself can bid, but both cannot bid simultaneously for same item / product in the same Tender. In case bids are received from both the Principal / OEM and the agent, bid received from the agent will be ignored.
D	If an agent submits Bid on behalf of the Principal / OEM, the same agent shall not submit bid on behalf of another Principal / OEM in the Tender, for the same Item / Product.



BP 200102A

GENERAL TERMS AND CONDITIONS OF ENQUIRY

11	Documentation:		
A	Indigenous Purchase		
	<p>Bidder shall arrange to send to the consignee, Original Tax invoice (Buyer's copy and duplicate for Transporter), Commercial invoice in duplicate, consignee copy of LR & 2 sets each of Packing list, Test certificate, Guarantee / Warranty certificate, O & M manuals (where applicable), immediately on despatch of the goods. The distribution of such documents will be specified in the Purchase order.</p> <p>In case of labour / mixed basis jobs, material is issued free of cost. Necessary material reconciliation is to be done and Free Issue Material Statement (FIMS) is to be submitted with each bill.</p>		
B	Foreign Purchase — Imports		
	<p>Seller shall send 1 set of following documents, in English, within 7 days of B/L date / 1 day of AWB date by courier to the Purchaser</p> <ol style="list-style-type: none"> Express / Original 'Clean on board' Bill of Lading / AWB. One set of Commercial Invoice, Packing list indicating container-wise Gross weight, Net weight, CBM volume, No. of packages with Dimensions of each package. Original Certificate of Country of Origin (COO) issued by Chamber of Commerce. COO shall be as per requisite format where duty concession is available under Preferential Trade/Comprehensive Economic Partnership/Free Trade agreement. Customs tariff heading (CTH)/ Harmonized System of Nomenclature (HSN) code of material should be mentioned on invoice and COO in all such cases. One set of Original Test Certificates and O&M Manual where called for. Fumigation / Phyto-Sanitary Certificate wherever cargo is packed in wooden packing or packing of plant origin material is used. Supplier should additionally forward 2 sets of original documents mentioned at point nos. 1 to 5 above along with Original Bill of Lading (OBL) or AWB through any international courier service/registered airmail within three (3) days of obtaining the same directly to the following: <table border="1" style="width: 100%; border-collapse: collapse;"> <tr> <td style="width: 50%; padding: 5px;"> AGM (M.S) Regional Operations Division BHEL 14th Floor Centre-1 World Trade Centre, Cuffe Parade Mumbai 400 005 INDIA Email: msseabpl@bhel.in (In case of Sea freight) msair@bhel.in (In case of Air freight) </td> <td style="width: 50%; padding: 5px;"> DGM (FIN- FP) 4th Floor, Administrative Bldg. BHEL Bhopal - 462022 (India) E-mail : fin_fp.bpl@bhel.in </td> </tr> </table> <p>And confirm forwarding details to AGM (CMM- FE), BHEL Bhopal at mmfe.bpl@bhel.in</p> <ol style="list-style-type: none"> In case the Seller decides to negotiate all 3 originals of B/L / AWB along with all original documents through negotiating Bank, non-negotiable documents (NNDs) consisting of copy of B/L / AWB & documents mentioned at Sl. no. 11- B2 to B5 will be sent by e-mail to the Purchaser at his e-mail address given in the PO with one copy to be mailed at mmfe.bpl@bhel.in as well as at msseabpl@bhel.in (for Sea shipment) or msair@bhel.in (for Air shipment). Other documents, as required, will be separately indicated in the Purchase Order. Additional expenditure, if any, incurred by the Purchaser by way of detention / demurrage, resulting out of delay attributable to the Seller in providing Negotiable documents, will be recovered from the Seller. <p>In case any discrepancy is raised by the Bankers / BHEL with respect to the documents submitted, vendor to facilitate clearance of goods through Delivery Order.</p> <p>Additionally, following requirements to be taken care of by the bidder during PO execution stage:</p> <ol style="list-style-type: none"> IEC (0588138690), GSTIN (23AAACB414612N) and email ID (mmfe.bpl@bhel.in) of BHEL Bhopal shall be clearly mentioned on B/L or AWB. As per Uniform Customs Practice (UCP 600) for documentary credits (L/C), presentation period allowed is maximum 21 days after the date of shipment. However, for geographically closer ports where sea voyage time is less than 3-4 weeks, a shorter presentation period shall be agreed upon. In case of CAD payment terms, Supplier shall send documents to BHEL's bank within 5 days of shipment. One set of original may be sent to any one of ROD, CMM-FE and MM, copy may be marked to the others. For Air shipments through non-CONSOL (i.e., not through BHEL ROD's contract), Delivery Order (DO) should be given to BHEL without insisting for Bank Release Order (BRO). AWB to be drawn with BHEL Bhopal as consignee. It must be ensured that original shipping/commercial documents, if not provided to BHEL outside banking channel, should reach BHEL's bank at least 10 days prior to cargo arrival at port. Part shipment and trans-shipment to be avoided to the extent possible especially where it is not possible to split shipping & commercial documents. Part shipment shall be strictly avoided for Airshipments. 	AGM (M.S) Regional Operations Division BHEL 14 th Floor Centre-1 World Trade Centre, Cuffe Parade Mumbai 400 005 INDIA Email: msseabpl@bhel.in (In case of Sea freight) msair@bhel.in (In case of Air freight)	DGM (FIN- FP) 4 th Floor, Administrative Bldg. BHEL Bhopal - 462022 (India) E-mail : fin_fp.bpl@bhel.in
AGM (M.S) Regional Operations Division BHEL 14 th Floor Centre-1 World Trade Centre, Cuffe Parade Mumbai 400 005 INDIA Email: msseabpl@bhel.in (In case of Sea freight) msair@bhel.in (In case of Air freight)	DGM (FIN- FP) 4 th Floor, Administrative Bldg. BHEL Bhopal - 462022 (India) E-mail : fin_fp.bpl@bhel.in		
C	General		
	<ol style="list-style-type: none"> For Hazardous chemicals, the materials safety data sheet (MSDS) is to be submitted. 		



BP 200102A

GENERAL TERMS AND CONDITIONS OF ENQUIRY

	<p>2. All certificates as called must be sent. BHEL may test any goods supplied and their decision is final irrespective of supplier's certificates. If test certificate and guarantee certificate are not received along with the document and stipulated in these specifications, BHEL reserves the right to get the material tested and recover the expenses from the supplier without awaiting supplier's confirmation</p> <p>3. Goods shall be properly packed to avoid transit damage. Suitable markings shall be provided to identify the goods with that of the PO No. and the consignee details.</p> <p>4. Goods shall be consigned to AGM (CRX), BHEL, Piplani, Bhopal - 462022, India, unless otherwise specified in the PO.</p>
12	Pricing Terms
A	Prices once quoted shall remain firm within the validity or any extension thereof for placement of order, till complete execution of the order, without any escalation/increase for any reason, whatsoever, unless specifically provided for in the Enquiry & PO. In case of foreign bidders, the quoted price shall be taken as inclusive of Third Party Inspection and testing charges as called for in the NIT.
13	Price Validity :
A	Unless stated otherwise in the enquiry, offer shall be valid for a period of 90 days from the date of Techno- commercial (Part-I) bid opening date.
14	Taxes & Duties - Indigenous Purchase
A	Bidder to ensure timely remittance of SGST, CGST , IGST as applicable in time as per law.
B	Bidder to ensure compliance to filing of monthly GST sales return including BHELs supplies by 10 th of next calendar month in the online GST portal wherever applicable.
C	Bidders to declare filing of timely returns and GST remittance/likely remittance /ITC adjustment along with invoice.
D	Bidder to submit invoices compliant with GST invoice Rules
E	Bidders to comply with all statutory provisions as may be applicable at the time of despatch/sale. Any additional financial liability to BHEL on account of non-compliance by bidders shall be borne by them and shall be adjusted / recovered from the bidders. BHEL reserves the right to review the existing offers / contracts for any revision in terms, which may arise due to change in any statutory provisions to ensure that the benefit accrues to BHEL.
F	Bidder to ensure TAX INVOICE submission along with consignment
G	In respect of cases where the liability to discharge GST is on BHEL under reverse charge mechanism, bidders have to ensure timely submission of invoices and delivery of material / services to BHEL, so that there is no mismatch on both activities. In case there is any additional financial liability on BHEL on account of default on the part of the bidder on submission or delivery of material / services the same shall be passed on to them.
H	In respect of free issue material by BHEL, bidders have to return the processed material within the time line as per the provisions of GST. In case of any additional tax liability on BHEL on account of non-compliance by the bidder, the additional financial implications on BHEL shall be passed on to the bidder
I	Bidders to provide the applicable HSN / SAC codes as called for in the enquiry
J	As per provisions of section 171 of the CGST Act 2017, bidders to pass on the anti-profiteering benefits accruing to them under GST regime to BHEL
K	<p>With reference to section 51 of CGST act 2017 read with notification no 50/2018 – Central tax dated 13.09.2018; BHEL will be liable to deduct TDS under GST with effect from 01.10.2018. Deduction shall be made @ 2% (1% CGST + 1% SGST) or 2% IGST (as applicable) of the payment made or the amount credited. Bidder to generate & submit invoices as per above.</p> <p>The amount of TDS shall be deposited to the Government account and BHEL shall issue TDS certificate to deductees, TDS deposited in the Government account will be reflected in the electronic cash ledger of the deductee who will be able to use the same for payment of tax or any other amount.</p> <p>Deduction of TCS along with additional TDS will be as per prevailing Government guidelines.</p>
15.	Taxes & Duties - Foreign Purchase — Imports
A	The offered prices shall be inclusive of all the Taxes and duties as applicable in the country of bidder / country of dispatch for the quoted CFR / CIF price.
16	Payment Terms-
A	Indigenous: 100% payment in 90 days of receipt (45 days for MSE including Udyog Aadhar/ Udhyan registered suppliers as per relevant act in force), subject to acceptance of material and relevant documents at BHEL. In case of despatch of material to site directly, site certification for receipt of materials is required unless otherwise provided for in the PO. Any deviation from the above payment terms, if accepted (by BHEL), shall be loaded @ SBI base rate + 6% for the purpose of bid evaluation.
B	Foreign: 100% against irrevocable, unconfirmed LC, payable within 90 days of the Bill of Lading (B/L) date or Payment terms of CAD payable on 90 th day of B/L / AWB. In case BHEL considers any deviation in payment terms i.e. early payment based on bidder's request, then bids shall be evaluated with loading of State bank of India Base rate plus 6%, for the credit

 BP 200102A	<h2 style="color: blue;">GENERAL TERMS AND CONDITIONS OF ENQUIRY</h2>
	<p>period short of 90 days. The LC shall be established 2 months prior to shipment date, valid for period of 90 days, unless agreed otherwise. Documents to be submitted as per UCP600 and should reach BHEL/ BHEL's bank at least 7 days prior to vessel arrival.</p>
C	<p>Foreign bidders to submit declaration of Permanent Establishment and Business Connection (PEBC) for remittances purpose. Declaration to be submitted in formats either in Annexure A or B whichever is applicable as per their transaction entered into with BHEL. In the absence of certificates from the bidder, withholding tax at applicable rates along with surcharge and cess will be recovered at the time of remittance to the bidder.</p>
D	<p>Foreign bidders to submit Tax Residency Certificate (TRC) & Form 10F (for obtaining DTAA benefits) as per Annexure C in respect of services. The TRC (tax residency certificate) is to be issued by the authorities of the government of bidder's country. If the informative part of the format (other than residency) is not furnished by the authorities the same may be furnished by the bidder as a declaration.</p>
17	<p>Inspection of Goods</p>
A	<p>The Bidder shall give adequate notice, of 1 week or as mutually agreed period, in writing to the Purchaser (in case Customer inspection is involved) or BHEL appointed TPIA about the date and place at which the goods will be ready for inspection/ testing, as provided for in the contract.</p>
B	<p>Purchaser or his authorized representative shall be entitled to carry out inspection of material and workmanship/Surveillance Audit at Bidder's premises or at his sub-contractor's premises at all reasonable times during execution of contract; Such inspection, examination and testing, if made, shall not absolve the Bidder from his obligations under the contract. Wherever required, BHEL may carry out testing at BHEL's testing Lab and in case of any rejection during such testing, replacement / rectification, as required, will have to be done by Supplier. If BHEL carries out any rectification of such rejected material, such cost will be recovered from Supplier's Bills. In case of Customer inspection as Supplier's Works, inspection clearance to be obtained from Customer and submitted to BHEL.</p>
C	<p>BHEL's representative from unit or Corporate Quality (CQ) is authorised to carry out audits along with TPIA at bidder's works before clearing the items for despatch.</p>
D	<p>All costs related to inspections and re-inspections shall be borne by the Bidder. In case of inspection by BHEL and / or BHEL's customer, the cost of to & fro passage and Boarding & Lodging shall be borne by the Purchaser / Customer, unless otherwise specifically agreed. In case of foreign bidders, the cost of third party inspection, where called for, shall be deemed to be included in the quoted price. Bidder shall be responsible to provide assistance such as labour, materials, electricity, fuels, stores, apparatus, instruments at his cost, as may be required and as may be reasonably demanded to carry out such tests effectively.</p>
E	<p>REJECTION: If any goods are rejected, BHEL shall be at liberty to take action as per following at the risk and cost of supplier:</p> <ul style="list-style-type: none"> a) Allow the supplier, wherever mutually agreed, to rectify the rejected goods at BHEL's works within reasonable time as fixed by BHEL. <li style="text-align: center;">Or b) Allow the supplier to make free replacement within a specified period. Rejected goods can be lifted by the supplier thereafter. <li style="text-align: center;">Or c) In case payment has been done, allow supplier to refund equivalent value of rejected material by NEFT / RTGS or furnish Bank Guarantee for same amount before lifting the rejected goods. Fresh replacement shall be regulated as per terms and condition of the original Purchase Order. In case payment has not been done, allow the supplier, wherever mutually agreed, to rectify the rejected goods at supplier's works within reasonable time as fixed by BHEL. <li style="text-align: center;">Or d) Take alternate procurement action from elsewhere and recover the difference in total cost to BHEL including services, if any, incurred by BHEL in this regard from the supplier. The supplier shall not be entitled to any gain on repurchase. <li style="text-align: center;">Or e) Terminate the contract either in part or in whole at the discretion of BHEL and recover the loss, if any, from the supplier. <li style="text-align: center;">Or

 BP 200102A	<h2 style="color: #0070C0;">GENERAL TERMS AND CONDITIONS OF ENQUIRY</h2>
---	--

	f) Any goods rejected by BHEL must be removed by the supplier after making payment through NEFT / RTGS within 30 days after receipt of the intimation of rejection. If bidder fails to lift or allow despatch of rejected material at his cost within 90 days from the intimation of rejection, his claim on rejected material shall cease.
18	Guarantee / Warranty and corresponding Repairs / Replacement of Goods
A	<p>Manufacturer's works test/inspection certificates shall be furnished along with the guarantee that material conforms strictly to the specification for general & special conditions as laid down in the purchase order. Goods shall comply with the specifications for material, workmanship and performance. The warranty shall be for a period of 12 months from the date of receipt. If the delivery is found non-compliant during the warranty period, leading to rejection, the Bidder shall arrange free replacement / repair of goods, within one month from the date of intimation or any mutually agreed period. The rejected goods shall be taken away by the Bidder at his cost and replaced on Delivered Duty Paid (DDP) (FOR - BHEL Stores/ designated destination basis) within such period. In the event of the Bidder's failure to comply, Purchaser may take action as appropriate, including Repair / Replenish rejected goods & disposal of rejections, at the risk & cost of the Bidder.</p> <p>In case the defects attributable to Bidder are detected during processing of the goods at purchaser's / his subcontractor's works, the Bidder shall be responsible for free replacement/ repair of the goods as required by the purchaser.</p>
19	Evaluation and Loading Criteria:
A	<p>The evaluation currency for this tender shall be INR.</p> <p>Evaluation of the tender shall be on the basis of delivered cost, i.e. 'total cost to BHEL' w.r.t the technical scope and commercial conditions finalized after techno-commercial clarifications (after considering, inter alia, Customs Duty and GST / Other taxes as applicable). Exchange rate (TT selling rate of State Bank of India) applicable on the date of Part-I bid opening shall be considered for evaluation of foreign bids. If the relevant day happens to be a bank holiday in India, then the FOREX rate as on the previous bank working day shall be taken for evaluation.</p> <p>Foreign suppliers shall ensure that the benefits as applicable under Comprehensive Economic Partnership Agreement (CEPA) with Government of India are disclosed in the bid & relevant documents such as Certificate of Country of Origin, issued by the appropriate authority in the country of Export, is provided by the bidder along with dispatch documents. Bids shall be evaluated with such applicable benefits. In the event of Bidder failing to provide appropriate documents for Purchaser to avail disclosed concessional duty benefits in India, financial loss, so incurred, will be to the Bidder's account.</p>
20	Variation of orders
A	No variation to the Purchase order is permitted unless authorised in writing and signed by or on behalf of purchase executive, BHEL Bhopal.
21	Sub-contract
A	BHEL's order or part there off, if further to be subcontracted in exceptional circumstances the details of subcontracting and to whom to be subcontracted shall be furnished to BHEL and written permission shall be obtained from BHEL. However, it shall not absolve the supplier of the responsibility of fulfilling BHEL order requirements.
22	Recovery / deductions of amount from supplier
A	<p>a Any amount on account of recovery from consignor / supplier under any condition shall be liable to be adjusted against any amount payable to the consignor/supplier against bills.</p> <p>b For any deficiency in supplies where deduction is involved, an amount as decided by BHEL, shall be deducted from supplier's bills.</p>
23	Safety clause for purchase orders
A	<p>The bidders shall maintain and ensure sufficient safety measures as required for inspections and test like HV test. Pneumatic test, Hydraulic test Spring test, Bend test, Material handling and safe working environment etc. to enable Inspection Agency for performing inspection.</p> <p>The bidder shall ensure that all the safety precautions specified in factories Act 1948 chapter-IV Section-21 to 41 are complied with respect to equipment's to be inspected.</p> <p>If any test equipment is found not complying with proper safety requirement, then the inspection agency may withhold inspection, till such time the desired safety requirements are met.</p>
24	Non-Disclosure Agreement
A	<p>All Drawing and technical documents relating to the product or it's manufacture submitted by one party to the other, prior or subsequent to the formation of contract, shall remain property of the submitting party. Drawing, technical documents or other technical information received by one party, shall not without the consent of the other party, be used for any other purpose than that, for which they were provided. Such technical information shall not without the consent of the submitting party, otherwise be used or copied, reproduced, transmitted or communicated to a third party. Patterns supplied by BHEL will remain BHEL's property which shall be returned by the bidder on demand to BHEL. Bidder shall in no way share or use such intellectual property of BHEL to promote his own business with others. <i>BHEL reserves the right to claim damages from the bidder, or take appropriate penal action as deemed fit against the bidder, for any infringement of the provisions contained herein.</i></p>



BP 200102A

GENERAL TERMS AND CONDITIONS OF ENQUIRY

	DRAWINGS, PATTERNS & TOOLS: All drawings, patterns & tools supplied by BHEL or made at BHEL's expense are BHEL's property. These cannot be used or referred to any other party and must only be used in the execution of BHEL's orders. These should be preserved at the supplier's cost for a period of not less than 5 years. Patterns & tools should be returned to BHEL within 90 days of issue of the same.
25	Settlement of Disputes & Arbitration
A	All questions/interpretations regarding subject matter of the Contract shall be decided by the Purchaser on the request of the Bidder and the decision of the Purchaser shall be final.
B	In case of dispute, steps shall be taken by the parties to the contract to settle the same through negotiations.
C	In case, dispute is not settled in negotiations, it shall be referred to Conciliator appointed by the competent authority of the Purchaser.
D	<p>Except as provided elsewhere in this Contract, in case amicable settlement is not reached between the Parties, in respect of any dispute or difference; arising out of the formation, breach, termination, validity or execution of the Contract; or, the respective rights and liabilities of the Parties; or in relation to interpretation of any provision of the Contract; or, in any manner touching upon the Contract, then, either Party may, by a notice in writing to the other party refer such dispute or difference to the sole arbitration of an arbitrator appointed by Head of the BHEL Unit/Region/Division issuing the Contract.</p> <p>The Arbitrator shall pass a reasoned award and the award of the Arbitrator shall be final and binding upon the Parties. Subject as aforesaid, the provisions of Arbitration and Conciliation Act 1996 (India) or Statutory modifications or re-enactments thereof and the rules made thereunder and for the time being in force shall apply to the arbitration proceedings under this clause. The seat of arbitration shall be Bhopal.</p> <p>The cost of arbitration shall be borne as per award of the Arbitrator.</p> <p>Subject to the arbitration in terms of Clause above, the Courts at Bhopal shall have exclusive jurisdiction over any matter arising out of or in connection with this Contract.</p> <p>Notwithstanding the existence or any dispute or differences and /or reference for the arbitration, the Contractor shall proceed with and continue without hindrance the performance of its obligations under this Contract with due diligence and expedition in a professional manner except where the Contract has been terminated by either Party in terms of this Contract. Administrative Mechanism for Resolution of CPSEs Dispute as stated in https://dpe.gov.in/guidelines/guidelines/chapters/2673.</p> <p>In the event of any dispute or difference relating to the interpretation and application of the provisions of the commercial Contract between Central Public Sector Enterprises (CPSEs)/Port Trusts inter-se and also between CPSEs and Government Departments/Organizations (excluding disputes concerning railways, Income Tax, Customs and Excise Departments), such dispute or difference shall be taken up by either party for resolution through Administrative Mechanism for Resolution of CPSEs Disputes (AMRCD) as mentioned in Department of Public Enterprises (DPE) Office Memorandum No. 4(1)/2013-DPE(GM)/FTS-1835 dated 22-05-2018 as amended from time to time."</p>
E	The Bidder shall continue to perform the contract, pending settlement of dispute(s).
26	Applicable Laws and Jurisdiction of Courts
A	Indian laws both substantive and procedural, for the time being in force, including modifications thereto, shall govern the Contract including Arbitration proceedings. The competent Courts at Bhopal in the State of Madhya Pradesh, India shall have sole jurisdiction.
27	RIGHT OF REJECTION /NON- PLACEMENT OF PO: BHEL reserves the right to accept the offers in part or in full, or cancel the Tender enquiry without assigning any reason.
28	Performance Bank Guarantee (PBG)/ Security Deposit (SD):
A	Wherever PBG (covering equipment / system / work performance guarantee) is called for in the Notice Inviting Tender (NIT) deviation shall not be accepted.
B	Bank Guarantee wherever called for, shall be in the BHEL prescribed format. In case the order is to be placed in foreign currency, the BG must also be in Foreign currency, so specified by the Purchaser.
C	Wherever Security Deposit (covering contract performance) is called for in the NIT, deviation shall not be accepted.
D	Composite 'Contract Performance Bank Guarantee' of matching value/ validity, where both Security Deposit and Performance Bank Guarantee are required, shall not be construed as deviation.
E	Wherever the contract is for supply of Goods processed on labour basis from BHEL supplied materials, the materials shall be issued against a suitable Bank guarantee as specified in the Enquiry.
F	Bidder agrees to submit performance security required for execution of the contract within the time period mentioned. In case of delay in submission of performance security, enhanced performance security which would include interest (SBI rate + 6%) for the delayed period, shall be submitted by the bidder. Further, if performance security is not submitted such security, the amount of performance security due shall be covered as per terms defined in NIT/ contract , from the bills along with due interest.
29	Benefits earmarked for Purchase from Micro & Small Enterprises (MSEs) –



BP 200102A

GENERAL TERMS AND CONDITIONS OF ENQUIRY

	<p>All benefits as per Government of India guidelines shall be given to eligible bidders. MSE bidders as defined by the MSMED Act as amended from time to time can avail the intended benefits only if they submit along with the offer, attested copies of relevant document stipulated in the MSMED Act or its rules/ regulations as amended from time to time and /or by the buyer. Non submission of such documents as stipulated hereinbefore will lead to consideration of their bids at par with other bidders. No benefit shall be applicable for the concerned for the tender enquiry, if any deficiency in the above required documents is not submitted before the price bid opening. If the tender is to be submitted through e-procurement portal, then the above required documents are to be uploaded on the portal. Documents should be notarized or attested by a Gazetted officer. This provision for MSE will apply subject to the condition that the participating MSE meets the tender requirements.</p> <p>In case of any change in the MSE status of the bidder, it shall be the responsibility of the bidder to notify the change as a part of the bid document. If at a later date it comes to the knowledge of BHEL, that the change in the status has not been intimated by the bidder and the order is obtained under the premise of an MSE then BHEL may reject the bid or, as the case may be, cancel the order and take necessary steps for suspension of the business dealing against the bidder as per the extant guidelines for suspension of business dealings with suppliers/ contractors of BHEL.</p> <p>Note: MSME benefits shall not be given to traders, Dealers or authorised agents.</p>
A	<p>MSEs shall be given tender documents free of cost and shall be exempted from payment of EMD. Tender documents shall be issued free of cost & no EMD wherever called for will be insisted upon. MSE bidders shall submit along with bid relevant documents w.r.t. their respective MSE status as per extant norms. Date to be reckoned for determining the deemed validity will be the last date of Technical bid submission. Non- submission of such document will lead to consideration of their bid, at par with other bidders and MSE status of such bidders shall be shifted to Non- MSE supplier till the supplier submit these documents.</p>
B	<p>In tender, participating MSEs quoting price within price band of L1+15% shall also be allowed to supply a portion of requirement by bringing down their price to L1 price in a situation where L1 price is from someone other than a MSE and such MSE shall be allowed to supply up to at least 25% of total tendered value. In case of more than one such MSE, the supply shall be shared proportionately.</p> <p>A quantum of 6.25% (25% out of target of 25%), so earmarked, will be reserved for MSE's owned by SC / ST entrepreneurs who submit their bid with relevant documents provided that in event of failure of such MSE(s) to participate in tender process or meet tender requirements and L1 price, 6.25% sub-target for procurement earmarked for MSE(s) owned by SC or ST entrepreneurs shall be met from other MSE(s).</p> <p>A quantum of minimum of 3% reservation within the above mentioned 25% reservation, so earmarked, will be reserved for MSE's owned by women entrepreneurs who submit their bid with relevant documents provided that in event of failure of such MSE(s) to participate in tender process or meet tender requirements and L1 price, 3% sub-target for procurement earmarked for MSE(s) owned by women entrepreneurs shall be met from other MSE(s).</p> <p>In case of indivisible tender, the full quantity shall be awarded to L1.</p>
C	<p>If an enterprise falling under MSE category as defined in the MSMED Act 2006, graduates to a higher category from its original category or beyond the purview of the Act, it shall continue to avail all non-tax benefits of its original category notified by the Ministry of Micro, Small and Medium Enterprise for a period of three years from the date of such graduation to the higher category.</p>
D	<p>MSE suppliers can avail the intended benefits only if they submit along with the offer, attested copies of either EM II certificate having deemed validity (five years from the date of issue of acknowledgement in EM II) or valid NSIC certificate or EM II certificate along with attested copy of a CA certificate (As per BHEL Format, where deemed validity of EM II certificate of five years has expired) applicable for the relevant financial year (latest audited). Date to be reckoned for determining the deemed validity will be the date of bid opening (Part 1 in case of two part bid). Non submission of such documents will lead to consideration of their bid at par with other bidders. No benefits shall be applicable for this enquiry if any deficiency in the above required documents are not submitted before price bid opening. If the tender is to be submitted through e-procurement portal, then the above required documents are to be uploaded on the portal. Documents should be notarized or attested by a Gazetted officer</p> <p>MSE bidders as defined by the MSMED Act as amended from time to time can avail the intended benefits only if they submit along with the offer, attested copies of either EM II certificate/ Udyog Aadhar Memorandum certificate having deemed validity (five years from the date of issue in acknowledgement in EM II/ Udyog Aadhar) or valid NSIC certificate or EM II/ Udyog Aadhar certificate along with attested copy of a CA certificate (Format enclosed as per Annexure I where deemed validity of EM II certificate/ Udyog Aadhar certificate of five years have expired) applicable for the relevant financial year (latest audited) or such other document as may be stipulated in the MSMED Act or its rules/ regulations as amended from time to time and /or by the buyer. The deemed validity will be assessed on the date of bid opening (Part 1 in case of two part bid). Non submission of such documents as stipulated hereinbefore will lead to consideration of their bids at par with other bidders. No benefit shall be applicable for the concerned for the tender enquiry, if any deficiency in the above required documents is not submitted before the price bid opening. If the tender is to be submitted through e-procurement portal, then the above required documents are to be uploaded on the portal. Documents should be</p>



BP 200102A

GENERAL TERMS AND CONDITIONS OF ENQUIRY

	<p>notarized or attested by a Gazetted officer. This provision for MSE will apply subject to the condition that the participating MSE meets the tender requirements.</p> <p>In case of any change in the MSE status of the bidder, it shall be the responsibility of the bidder to notify the change as a part of the bid document. If at a later date it comes to the knowledge of BHEL, that the change in the status has not been intimated by the bidder and the order is obtained under the premise of an MSE then BHEL may reject the bid or, as the case may be, cancel the order and take necessary steps for suspension of the business dealing against the bidder as per the extant guidelines for suspension of business dealings with suppliers/ contractors of BHEL.</p> <p>In case if all the items being procured under the enquiry fall under category of reserved items as defined in "Public Procurement Policy for Micro and Small Enterprises (MSEs) Order, 2012" and if any of the MSE bidder(s) is techno-commercially qualified then the price bids of only MSE bidders shall be opened. If no MSE bidder is techno-commercially qualified, then price bids of all techno-commercially qualified bidders shall be opened.</p>																								
30	<p>Integrity Pact (IP) — Independent external monitors (IEM) For tenders in which integrity pact is applicable, following points stand valid :</p>																								
A	<p>IP is a tool to ensure that activities and transactions between the company and its bidders/contractors are handled in a fair, transparent and corruption free manner. A panel of Independent External Monitors (IEMs) have been appointed to oversee implementation of IP in BHEL.</p> <p>The IP as enclosed with the tender is to be submitted (duly signed by authorized signatory who signs in the offer) along with techno commercial bid. Only those bidders who have entered into such an IP with BHEL would be competent to participate in the bidding. In other words, entering into this pact would be a preliminary qualification.</p> <p>Name: ----- Address: ----- E-mail : -----</p> <p style="text-align: right;">} As indicated in NIT / enquiry</p>																								
B	<p>Please refer section 8 of the IP for roles and responsibilities of IEMs. In case of any complaint arising out of tendering process, the matter may be referred to the IEM mentioned in the tender.</p> <p>NOTE: No routine correspondence shall be addressed to the IEM (phone / post/e-mail) regarding the clarifications, time extensions or any other administrative queries, etc. on the tender issued. All such clarifications/ issues shall be addressed directly to the tender issuing (procurement) department.</p> <p>For all clarifications/ issues related to the tender, please contact:</p> <table border="1" style="width: 100%; border-collapse: collapse;"> <thead> <tr> <th style="width: 60%;"></th> <th style="width: 20%;">(1)</th> <th style="width: 20%;">(2)</th> </tr> </thead> <tbody> <tr> <td>Name</td> <td></td> <td></td> </tr> <tr> <td>Landline No.</td> <td></td> <td></td> </tr> <tr> <td>Mobile No.</td> <td></td> <td></td> </tr> <tr> <td>Email</td> <td></td> <td></td> </tr> <tr> <td>Dept.</td> <td></td> <td></td> </tr> <tr> <td>Address</td> <td></td> <td></td> </tr> <tr> <td>Fax</td> <td></td> <td></td> </tr> </tbody> </table>		(1)	(2)	Name			Landline No.			Mobile No.			Email			Dept.			Address			Fax		
	(1)	(2)																							
Name																									
Landline No.																									
Mobile No.																									
Email																									
Dept.																									
Address																									
Fax																									
31	<p>Fraud Prevention Policy : The Bidder along with its associate/ collaborators/ sub-contractors/ sub-bidders/ consultants/ service providers shall strictly adhere to BHEL Fraud Prevention Policy displayed on BHEL website www.bhel.com and shall immediately bring to the notice of BHEL Management about any fraud or suspected fraud as soon as it comes to their notice.</p>																								
32	<p>Integrity Commitment: The offers of the bidders who are under suspension as also the offers of the bidders, who engage the services of the banned firms, shall be rejected. The list of banned firms is available on BHEL website www.bhel.com.</p> <p>Integrity commitment, performance of the contract and punitive action thereof :</p>																								
A	<p>Commitment by BHEL: BHEL commits to take all measures necessary to prevent corruption in connection with the tender process and execution of the contract. BHEL will during the tender process treat all bidder(s) in a transparent and fair manner, and with equity.</p>																								
B	<p>Commitment by bidder / Supplier / Contractor :</p>																								
B1	<ul style="list-style-type: none"> - The bidder / supplier / contractor commit to take all measures to prevent corruption and will not directly or indirectly influence any decision or benefit which he is not legally entitled to nor will act or omit in any manner which tantamount to an offence punishable under any provision of the Indian Penal code, 1860 or any other law in force in India. - The bidder / supplier / contractor will, when presenting his bid, disclose any and all payments he has made, and is committed to or intends to make to agents, brokers or any other intermediaries in connection with the award of the contract and shall adhere to relevant guidelines issued from time to time by govt. of India / BHEL - The bidder / supplier / contractor will perform / execute the contract as per the contract terms & conditions and will not default without any reasonable cause, which causes loss of business / money / reputation to BHEL. 																								

 BP 200102A	<h2 style="color: blue;">GENERAL TERMS AND CONDITIONS OF ENQUIRY</h2>
B2	<p>If any bidder / supplier / contractor during pre-tendering / tendering / post tendering / award / execution / post-execution stage indulges in mal-practices, cheating, bribery, fraud or / and other misconduct or formation of cartel so as to influence the bidding process or influence the price or acts or omits in any manner which tantamount to an offence punishable under any provision of the Indian Penal Code, 1860 or any other law in force in India, then action may be taken against such bidder / supplier / contractor as per the extant guidelines of the company available on www.bhel.com and / or under applicable legal provisions.</p>
B3	<p>Preventive checks to eliminate suspected cartel formation between suppliers The Bidder declares that they will not enter into any illegal or undisclosed agreement or understanding, whether formal or informal with other Bidder(s). This applies in particular to prices, specifications, certifications, subsidiary contracts, submission or non-submission of bids or any other actions to restrict competitiveness or to introduce cartelization in the bidding process. In case, the Bidder is found having indulged in above activities, suitable action shall be taken by BHEL as per extant policies/ guidelines</p> <p>Declaration by Bidders We declare that the following family firms or sister concern affiliates/ subsidiary firms are participating in the tender No _____</p> <p>1.0 _____ 2.0 _____ 3.0 _____</p> <p>I _____ hereby declare on behalf of M/s _____ and family firms or sister concern affiliates/ subsidiary firms listed above that we are not indulging in cartel formation for Enquiry No _____.</p> <p style="text-align: right;">(_____) For M/s _____ Seal and Sign</p>
33	<p>Public Procurement (Preference to Make in India), Order 2017 For this procurement, Public Procurement (Preference to Make in India), Order 2017 Dtd 15.06.2017 and 28.05.2018 and subsequent orders issued by both DPIIT and the respective nodal ministries shall be applicable For this procurement, the local content to categorise a supplier as a Class I local supplier/ Class II local supplier / Non-Local supplier is as defined in Public Procurement (Preference to Make in India), Order 2017 dated 04.06.2020 issued by DPIIT. In case of subsequent orders issued by the nodal ministry changing the definition of local content for the items of the NIT, the same shall be applicable even if issued after issue of this NIT, but before opening of Part-II bids against this NIT.</p> <p>Bidder to mention the percentage of local content and place of value addition to manufacture these items in the tender.</p>
34	<p>RESTRICTION UNDER RULE 144 (xi) OF THE GENERAL FINANCIAL RULES 2017: As per latest government guidelines</p>
I	<p>Any bidder from a country which shares a land border with India will be eligible to bid in this tender only if the bidder is registered with the competent authority.</p>
II	<p>“Bidder” (including the term ‘tenderer’, ‘consultant’ or service provider’ in certain contexts means any person or firm or company , including any member of a consortium or joint venture (that is an association of several persons , or firms or companies) every artificial juridical person not falling in any of the description of bidders stated hereinbefore, including any agency, branch or office controlled by such person, participating in procurement process.</p>
III	<p>Bidder from a country which shares a land border with India” for the purpose of this order means: -</p> <ol style="list-style-type: none"> a. An entity incorporated, established or registered in such a country; or b. A subsidiary of an entity incorporated, established or registered in such a country; or c. An entity substantially controlled through entities incorporated, established or registered in such a county; or d. An entity whose beneficial owner is situated in such a country; or e. An Indian (or other) agent of such an entity; or f. A natural person who is a citizen of such a country; or g. A consortium or joint venture where any member of the consortium or joint venture falls under any of the above.



BP 200102A

GENERAL TERMS AND CONDITIONS OF ENQUIRY

IV	<p>The beneficial owner for the purpose of (iii) above will be as under:</p> <ol style="list-style-type: none"> 1. In case of company or Limited Liability Partnership, the beneficial owner is the natural person(s), who, whether acting alone or together, or through one or more juridical person, has a controlling ownership interest or who exercises control through other means. <p>Explanation –</p> <ol style="list-style-type: none"> a. "Controlling ownership interest" means ownership of or entitlement to more than twenty-five per cent of shares or capital or profits of the company. b. "Control" shall include the right to appoint majority of the directors or to control the management or policy decisions including by virtue of their shareholding or management rights or shareholder's agreements or voting agreements. <ol style="list-style-type: none"> 2. In case of a partnership firm, the beneficial owner is the natural person(s) who, whether acting alone or together, or through one or more juridical person, has ownership of entitlement to more than fifteen percent of capital or profits of the partnership; 3. In case of an unincorporated association or body of individuals, the beneficial owner is the natural person(s), who, whether acting alone or together, or through one or more juridical person, has ownership of or entitlement to more than fifteen percent of the property or capital or profits of such association or body of individuals; 4. Where no natural person is identified under (1) or (2) or (3) above, the beneficial owner is the relevant natural person who holds the position of senior managing official; 5. In case of a trust, the identification of beneficial owner(s) shall include identification of the author of the trust, the trustee, the beneficiaries with fifteen percent or more interest in the trust and any other natural person exercising ultimate effective control over the trust through a chain of control or ownership.
V	An Agent is a person employed to do any act for another, or to represent another in dealings with third person.
VI	<p>Model certificate for Tenders</p> <p><i>"I have read the clause regarding restrictions on procurement from a bidder of a country which shares a land border with India; I certify that this bidder is not from such a country or, if from such a country, has been registered with the competent authority. I hereby certify that this bidder fulfills all requirements in this regards and is eligible to be considered. [Where applicable , evidence of valid registration by the Competent Authority shall be attached]."</i></p>

Note:

- 1.0 Tender Specific conditions shall override relevant provisions of this GTC
- 2.0 In the event of any change as notified by Govt. of India same will supersede.



FORM NO. MM 6527

Rev - 03

B.H.E.L., P.O. TERMS & CONDITIONS (INDIGENOUS)

The purchase order is subject to the following terms & conditions unless otherwise specified and directed :-

1. ORDER ACKNOWLEDGEMENT :

Order acknowledgement in the enclosed format must reach the concerned officer of Materials Management Divisions within 4 weeks of issue of purchase order. Failure to do so within stipulated period will be deemed to mean that the order has been accepted by the supplier.

2. PACKING :

- The supplier shall securely protect and pack the goods against loss, damage or corrosion in transit. Packing shall allow for easy removal and checking on site and comply with carrier conditions of packing or established trade practice.
- Cases and packing materials shall be supplied free of charge unless otherwise agreed to. Wherever specifically agreed to, empties shall be returned at suppliers expenses but no liability will be accepted by BHEL in respect thereof.
- Damage to the consignment resulting out of poor/inferior packing shall be to the account of the supplier.

3. MARKING :

- The following details to be clearly marked on each case/box/packing/bundle and reel.
 - Consignee i) BHEL Order No. ii) Gross weight iv) Net weight v) Dimensions in CMS vi) Brief description of item vii) BHEL Destination Code (refer purchase order) viii) Consignor.
- All markings for safety, proper handling, storage, protection etc. are to be clearly marked on the case as per Indian Standard.

4. CONSIGNEE :

Unless otherwise mentioned, all goods shall be consigned as noted below :

- Rail : Sr. Manager, Central Receiving Section, HESG Central Railway via Bhopal.
Note : Goods must not be consigned to Bhopal Station, HESG via Bhopal in an assisted siding in IRCA Chapter VIII page 373. All goods in small or wagon loads should be booked to this siding.
- Road : Sr. Manager, Central Receiving Section Block VII, BHEL Despatches must be arranged through BHEL's approved transporters on door delivery basis.
- Post/Air parcel : Sr. Manager Central Receiving Section Block VII, BHEL, Bhopal - 462 022.
- Supplier not complying with instructions at (a), (b) & (c) above shall do so at their risk and cost.

5. PRICE :

Unless specifically agreed to other wise, all prices shall be treated as FIRM.

6. TERMS OF PAYMENT :

The standard payment terms shall be as specified below and specified in the Purchase Order. It is however made clear that BHEL shall not accept any interest liability.

A. Local ancillary and SSI Units and other local parties.

100% payment on receipt and acceptance of Materials within 90 days of the date of receipt in BHEL.

B. Outstation SSI and other Suppliers.

BHEL prefers 'door delivery' of material in which case payment shall be within 90 days from the date of despatch. In case documents through Bank 100% payments within 90 days from the date of despatch of Material. Delivery at our works.

In case of Payments through other negotiable instrument like Bill of Exchange/Hurdies etc. then the Material to be delivered on 'door delivery' basis. 100% payment within 90 days from date of acceptance of negotiable Bill. of Exchange/Hurdies. Hurdies will be accepted by BHEL within 7 days of presentation or otherwise in accordance with contract.

नोट - भुगतान के पंजीकृत डॉक द्वारा भेजा जायेगा। डॉक विनाग द्वारा भेक विलय से पहुंचने अक्षय/मोड-कालवाजी या अन्य कारणों से अनधिकृत हानि से आपो पर हुई खोरे के लिए बीएचईएल उत्तरदायी नहीं होगा।
NOTE :- The cheque will be sent by Registered post and the Company will in no way be responsible, if loss occurs due to delay by postal authorities or cheque falling into improper hands through forgery of fraud.

7. DOCUMENTATION :

The supplier shall forward four sets of the document as detailed below :-

- 1 set to the concerned Purchase officer, Materials management Deptt. 2nd floor Administrative Building, BHEL Bhopal-462 022, Comprising of

i) Invoice	1 copy
ii) Challan/Despatch Advice note	2 copies
iii) Guarantee Certificate	3 copies
iv) Test Certificate	4 copies
v) Proforma for insurance	2 copies
vi) Photo copy of ED Paying Document	1 copy
vii) Photo copy of LR/RR	1 copy
- 1 set to Dy. General Manager, Central Receiving Section, Block-VII, BHEL, Bhopal-462 022 comprising of :-
 - Original LR/RR (if not negotiated through Bank)
 - Invoice
 - Challan/Despatch advice note
 - Excise Duty Paying document (Excise challan)
- 1 set to Dy. Manager Purchase Bills Section, 4th floor Administrative Building BHEL, Bhopal-462022 comprising of :-
 - Signed invoice
 - Excise Duty Paying Document (duplicate/photo copy)
- 1 set to the bank in case of documents negotiated through Bank separately to each Purchase order comprising of :
 - Original RR/LR
 - Signed Invoice
 - Original Excise duty Paying Document (only in case of rail despatches)
 - Test Certificate
 - Guarantee certificate

Notes :

'C' form shall be issued directly to the supplier. No 'C' form shall be exchanged against documents through Bank. This will be issued once in a year against a P.O.
In case of materials going to site directly, 'C' form will be issued after suppliers confirmation that he will issue corresponding E1 form.

- Excise only : The original Excise duty paying document or equivalent document indicating tariff Item No. and drawn in favour of BHEL, Bhopal for each consignment shall accompany the transporters in case of road despatches and with R/R in case of rail despatches. In case of any other mode of despatch (such as Regd. Post Parcel /Air Parcel etc.) the same shall be forwarded to Sr. Manager, Central Receiving Section, Block VII, BHEL, Bhopal-462 022 directly by registered post/hand delivery. The Excise duty paying document must not be enclosed inside the packing case. No Excise Duty shall be paid in the absence of the above document.

8. SALES TAX :

BHEL Bhopal is registered as a manufacturer under Sales Tax registration No. BPL/HEL/11, MPST No. BPL/HKL/5, Sales Tax declaration form will be issued as per rules. Supplier is to furnish E-1 form within 15 days after receipt of 'C' form in favour of Sr. Mgr. (Sales Tax) Materials Management Deptt.
for the despatches direct to customers i.e. Destination other than BHEL Bhopal Otherwise full CST & Penalty will be paid by Supplier.

supply. Wherever possible despatch particulars like MR with date, PO No. and value should be furnished by TLX. TLG to Sr. Mgr. concerned group and to our underwriters (Gram : National Insurance TLX : 0705-336 cable/NIC Div.

11. QUALITY :

All the goods supplied and services rendered must be the best of their kind and conform to the specification mentioned in the order and/ or to be strictly in accordance with approved samples or drawings.

12. INSPECTION :

All the goods and works are subject to BHEL's inspection or where stipulated by BHEL's client or his authorised nominees at supplier works. Despatch can be arranged against despatch clearance note issued by BHEL inspection and/or customer's representative, However final acceptance is subject to inspection and acceptance at the destination.

13. TEST CERTIFICATE :

All certificates called for in the specification or order must be sent by Registered Post with the Advice Note, BHEL may test any goods supplied and their decision is final irrespective of supplier's certificates.

If test certificate and guarantee certificate are not received alongwith the document and stipulated in these specifications, BHEL reserves the right to get the material tested and recover the expenses from the supplier without awaiting suppliers confirmation.

14. GUARANTEE :

All goods shall be free from any defect due to faulty design/material and / or workmanship/erection (Where called for) and will be guaranteed for a period of twelve months from the date of commissioning of the goods or 24 months from the date of despatch whichever is earlier. However, for any "Type defects" Supplier will be responsible even after 24 months, if failure of the item on a/c of this.

Where the contract stipulates submission of Bank guarantee the Suppliers shall get validity period of the same extended from the Bank as and when required, failing which it will be treated as Breach of the terms of the contract and the contract is liable to be cancelled and the loss suffered by BHEL shall be recoverable from the supplier.

15. REJECTION :

If any goods are rejected, BHEL shall be at liberty to take action as per following at the risk and cost of supplier:

- Allow the supplier, where ever mutually agreed, to rectify the rejected goods at BHEL's work within reasonable time as fixed by BHEL.

or

- Allow the supplier to make free replacement within a specified period. Rejected goods can be lifted by the supplier thereafter.

or

- Allow supplier to refund the full amount paid to him by BHEL by a demand draft before lifting the rejected goods. Fresh replacement shall be regulated as per terms and condition of the original Purchase Order.

or

- Take alternate procurement action from elsewhere and recover the difference in cost. If any, incurred by BHEL in this regard from the supplier. The supplier shall not be entitled to any gain on repurchase.

or

- Terminate the contract either in part or in whole at the discretion of BHEL and recover the loss if any from the supplier.

or

- Any goods rejected by BHEL must be removed by the supplier after making payment through Demand Draft within 45 days from the date of intimation of rejection or 30 days after receipt to of the intimation of rejection which ever is earlier. If the goods are not removed within the period stipulated above, the goods shall be liable to be sold by BHEL and the proceeds there of shall be adjusted towards storage charge and or other dues.

16. DRAWINGS, PATTERNS & TOOLS :

All drawings as also all patterns and tool supplied by BHEL or made at BHEL's expense are BHEL's property. These cannot be used or referred to any other party and must only be used in the execution of BHEL's orders. These shall be preserved at the supplier's cost for a period of not less than 5 year.

17. INDEMNITY :

Supplier shall indemnify BHEL against the following:

- Any claim or infringement of letters, patent or registered design by the use or sale of any article or materials supplied to BHEL and against all costs and damages which may incur in any action for such infringement or for which BHEL become liable in any such action.

- All claims for injury or damages caused by the suppliers negligence or the negligence of supplier's employee or arising from any defect in the goods supplied or on the work carried out by the supplier.

- All claims for injury to the supplier's employees or agents employees whilst on BHEL premise.

18. SUB-CONTRACT :

BHEL's order or part there off, if further to be sub-contracted in exceptional circumstances the details of subcontracting and to whom to be subcontracted shall be furnished to BHEL and written permission shall be obtained from BHEL. However it shall not absolve the supplier of the responsibility of fulfilling BHEL order requirements.

19. VARIATION OF ORDERS :

No variation to this order is permitted unless authorised in writing and signed by or on behalf of purchase executive, BHEL Bhopal.

20. LIQUIDATION DAMAGE/PENALTY :

- Failure to effect supply by the time specified in the order or period of extension granted in writing by BHEL will make the supplier liable to pay liquidated damage/an unconditional penalty, as the case may be, of 1/2% (Half Percent) of the price of the goods in arrears per week at the discretion of BHEL, subject to a maximum of 10% of the order value.

- If the material is not supplied within stipulated time BHEL shall be within their right to cancel the contract and purchase, the material through any other source at the risk and cost of the supplier. In such an event it shall be obligatory on the defaulting supplier to make good any loss suffered by BHEL.

21. ADJUSTMENT OF RECOVERY OF AMOUNT PAYABLE BY THE SUPPLIER :

Any amount payable by the consignee/supplier under any of the condition of this contract shall be liable to be adjusted against any amount payable to the consignee/supplier under any other/works/contract awarded to him. This is without prejudice to any other action as may be deemed fit by BHEL.

22. JURISDICTION :

All suits or any matters arising out of this purchase order shall be lie in BHOHAL COURTS ONLY.

23. ARBITRATION :

In all cases of disputes emanating from and in reference to this Purchase Order the matter shall be referred to the arbitration of the sole arbitration of the Executive Director/ GM of BHEL, Bhopal or any other person (including an employee of BHEL, even though he had to deal with the matter relating to this P.O. in any manner) nominated by the said Executive Director/ GM to act as sole arbitrator. The arbitration shall be under THE ARBITRATION AND CONCILIATION ACT OF 1996 and the rules there under. The arbitrator may from time to time with the consent of the parties enlarge the time for making and publishing the award.

24. HAZARDOUS/TOXIC CHEMICALS :

Supplier to supply the "Material Safety Data Sheet (MSDS)" in the standard prescribed proforma as per the environment act Schedule-9 Rule 17, Manufacture, Storage And IMPORT of chemicals Rule-1989.

25. SAFETY CLAUSE FOR PURCHASE ORDERS :

The vendors shall maintain and ensure sufficient safety measures as required for inspections and test like HV test, Pneumatic test, Hydraulic test, Spring test, Bend test, Material handling and safe working environment etc. to enable Inspection Agency for performing inspection.

The vendor shall ensure that all the safety precautions specified in factories Act 1948 Chapter-IV Section-21 to 24 are complied with regard to employees to be employed.

DECLARATION BY VENDOR

We declare that the following family firms or sister concern affiliates / subsidiary firms are participating in the tender no E

1.0

2.0

3.0

I, hereby declare on behalf of M/s and the family firms or sister concern affiliates / subsidiary firms listed above that we are not indulging in cartel formation for Enquiry no E

(.....)

For M/s

(Seal & sign)

No. P-45021/2/2017-PP (BE-II)
Government of India
Ministry of Commerce and Industry
Department for Promotion of Industry and Internal Trade
(Public Procurement Section)

Udyog Bhawan, New Delhi
Dated: 04th June, 2020

To

All Central Ministries/Departments/CPSUs/All concerned

ORDER

Subject: Public Procurement (Preference to Make in India), Order 2017– Revision; regarding.

Department for Promotion of Industry and Internal Trade, in partial modification [Paras 2, 3, 5, 9(a), 9(b) and 10(b) modified and Para 3A added] of Order No.P-45021/2/2017-B.E.-II dated 15.6.2017 as amended by Order No.P-45021/2/2017-B.E.-II dated 28.05.2018 and Order No.P-45021/2/2017-B.E.-II dated 29.05.2019, hereby issues the revised 'Public Procurement (Preference to Make in India), Order 2017' dated 04.06.2020 effective with immediate effect.

Whereas it is the policy of the Government of India to encourage 'Make in India' and promote manufacturing and production of goods and services in India with a view to enhancing income and employment, and

Whereas procurement by the Government is substantial in amount and can contribute towards this policy objective, and

Whereas local content can be increased through partnerships, cooperation with local companies, establishing production units in India or Joint Ventures (JV) with Indian suppliers, increasing the participation of local employees in services and training them,

Now therefore the following Order is issued:

1. This Order is issued pursuant to Rule 153 (iii) of the General Financial Rules 2017.
2. **Definitions:** For the purposes of this Order:

'Local content' means the amount of value added in India which shall, unless otherwise prescribed by the Nodal Ministry, be the total value of the item procured (excluding net domestic indirect taxes) minus the value of imported content in the item (including all customs duties) as a proportion of the total value, in percent.

'Class-I local supplier' means a supplier or service provider, whose goods, services or works offered for procurement, has local content equal to or more than 50%, as defined under this Order.

'Class-II local supplier' means a supplier or service provider, whose goods, services or works offered for procurement, has local content more than 20% but less than 50%, as defined under this Order.

.....Contd. p/2

'Non - Local supplier' means a supplier or service provider, whose goods, services or works offered for procurement, has local content less than or equal to 20%, as defined under this Order.

'L1' means the lowest tender or lowest bid or the lowest quotation received in a tender, bidding process or other procurement solicitation as adjudged in the evaluation process as per the tender or other procurement solicitation.

'Margin of purchase preference' means the maximum extent to which the price quoted by a "Class-I local supplier" may be above the L1 for the purpose of purchase preference.

'Nodal Ministry' means the Ministry or Department identified pursuant to this order in respect of a particular item of goods or services or works.

'Procuring entity' means a Ministry or department or attached or subordinate office of, or autonomous body controlled by, the Government of India and includes Government companies as defined in the Companies Act.

'Works' means all works as per Rule 130 of GFR- 2017, and will also include 'turnkey works'.

3. Eligibility of 'Class-I local supplier'/ 'Class-II local supplier'/ 'Non-local suppliers' for different types of procurement

(a) In procurement of all goods, services or works in respect of which the Nodal Ministry / Department has communicated that there is sufficient local capacity and local competition, only 'Class-I local supplier', as defined under the Order, shall be eligible to bid irrespective of purchase value.

(b) In procurement of all goods, services or works, not covered by sub-para 3(a) above, and with estimated value of purchases less than Rs. 200 Crore, in accordance with Rule 161(iv) of GFR, 2017, Global tender enquiry shall not be issued except with the approval of competent authority as designated by Department of Expenditure. Only 'Class-I local supplier' and 'Class-II local supplier', as defined under the Order, shall be eligible to bid in procurements undertaken by procuring entities, except when Global tender enquiry has been issued. In global tender enquiries, 'Non-local suppliers' shall also be eligible to bid along with 'Class-I local suppliers' and 'Class-II local suppliers'.

(c) For the purpose of this Order, works includes Engineering, Procurement and Construction (EPC) contracts and services include System Integrator (SI) contracts.

3A. Purchase Preference

(a) Subject to the provisions of this Order and to any specific instructions issued by the Nodal Ministry or in pursuance of this Order, purchase preference shall be given to 'Class-I local supplier' in procurements undertaken by procuring entities in the manner specified here under.

.....Contd. p/3

- 3 -

(b) In the procurements of goods or works, which are covered by para 3(b) above and which are divisible in nature, the 'Class-I local supplier' shall get purchase preference over 'Class-II local supplier' as well as 'Non-local supplier', as per following procedure:

- i. Among all qualified bids, the lowest bid will be termed as L1. If L1 is 'Class-I local supplier', the contract for full quantity will be awarded to L1.
- ii. If L1 bid is not a 'Class-I local supplier', 50% of the order quantity shall be awarded to L1. Thereafter, the lowest bidder among the 'Class-I local supplier' will be invited to match the L1 price for the remaining 50% quantity subject to the Class-I local supplier's quoted price falling within the margin of purchase preference, and contract for that quantity shall be awarded to such 'Class-I local supplier' subject to matching the L1 price. In case such lowest eligible 'Class-I local supplier' fails to match the L1 price or accepts less than the offered quantity, the next higher 'Class-I local supplier' within the margin of purchase preference shall be invited to match the L1 price for remaining quantity and so on, and contract shall be awarded accordingly. In case some quantity is still left uncovered on Class-I local suppliers, then such balance quantity may also be ordered on the L1 bidder.

(c) In the procurements of goods or works, which are covered by para 3(b) above and which are not divisible in nature, and in procurement of services where the bid is evaluated on price alone, the 'Class-I local supplier' shall get purchase preference over 'Class-II local supplier' as well as 'Non-local supplier', as per following procedure:

- i. Among all qualified bids, the lowest bid will be termed as L1. If L1 is 'Class-I local supplier', the contract will be awarded to L1.
- ii. If L1 is not 'Class-I local supplier', the lowest bidder among the 'Class-I local supplier', will be invited to match the L1 price subject to Class-I local supplier's quoted price falling within the margin of purchase preference, and the contract shall be awarded to such 'Class-I local supplier' subject to matching the L1 price.
- iii. In case such lowest eligible 'Class-I local supplier' fails to match the L1 price, the 'Class-I local supplier' with the next higher bid within the margin of purchase preference shall be invited to match the L1 price and so on and contract shall be awarded accordingly. In case none of the 'Class-I local supplier' within the margin of purchase preference matches the L1 price, the contract may be awarded to the L1 bidder.

✓ (d) "Class-II local supplier" will not get purchase preference in any procurement, undertaken by procuring entities.

.....Contd. p/4

- 4 -

4. **Exemption of small purchases:** Notwithstanding anything contained in paragraph 3, procurements where the estimated value to be procured is less than Rs. 5 lakhs shall be exempt from this Order. However, it shall be ensured by procuring entities that procurement is not split for the purpose of avoiding the provisions of this Order.
5. **Minimum local content:** The local content requirement to categorize a supplier as 'Class-I local supplier'/ 'Class-II local supplier'/ 'Non-local supplier' shall be as defined in the Para "2" of the Order. No change is permissible on this account. However, if any nodal Ministry/ Department finds that for any particular item, pertaining to their nodal ministry/department, the definition of Local Content, as defined in the Order, is not workable/ has limitations, it may notify alternate suitable mechanism for calculation of local content for that particular item.
6. **Margin of Purchase Preference:** The margin of purchase preference shall be 20%.
7. **Requirement for specification in advance:** The minimum local content, the margin of purchase preference and the procedure for preference to Make in India shall be specified in the notice inviting tenders or other form of procurement solicitation and shall not be varied during a particular procurement transaction.
8. **Government E-marketplace:** In respect of procurement through the Government E-marketplace (GeM) shall, as far as possible, specifically mark the items which meet the minimum local content while registering the item for display, and shall, wherever feasible, make provision for automated comparison with purchase preference and without purchase preference and for obtaining consent of the local supplier in those cases where purchase preference is to be exercised.
9. **Verification of local content:**
 - a. The 'Class-I local supplier'/ 'Class-II local supplier' at the time of tender, bidding or solicitation shall be required to indicate percentage of local content and provide self-certification that the item offered meets the local content requirement for 'Class-I local supplier'/ 'Class-II local supplier', as the case may be. They shall also give details of the location(s) at which the local value addition is made.
 - b. In cases of procurement for a value in excess of Rs. 10 crores, the 'Class-I local supplier'/ 'Class-II local supplier' shall be required to provide a certificate from the statutory auditor or cost auditor of the company (in the case of companies) or from a practicing cost accountant or practicing chartered accountant (in respect of suppliers other than companies) giving the percentage of local content.
 - c. Decisions on complaints relating to implementation of this Order shall be taken by the competent authority which is empowered to look into procurement-related complaints relating to the procuring entity.

.....Contd. p/5

- d. Nodal Ministries may constitute committees with internal and external experts for independent verification of self-declarations and auditor's/ accountant's certificates on random basis and in the case of complaints.
- e. Nodal Ministries and procuring entities may prescribe fees for such complaints.
- f. False declarations will be in breach of the Code of Integrity under Rule 175(1)(i)(h) of the General Financial Rules for which a bidder or its successors can be debarred for up to two years as per Rule 151 (iii) of the General Financial Rules along with such other actions as may be permissible under law.
- g. A supplier who has been debarred by any procuring entity for violation of this Order shall not be eligible for preference under this Order for procurement by any other procuring entity for the duration of the debarment. The debarment for such other procuring entities shall take effect prospectively from the date on which it comes to the notice of other procurement entities, in the manner prescribed under paragraph 9h below.
- h. The Department of Expenditure shall issue suitable instructions for the effective and smooth operation of this process, so that:
 - i. The fact and duration of debarment for violation of this Order by any procuring entity are promptly brought to the notice of the Member-Convenor of the Standing Committee and the Department of Expenditure through the concerned Ministry /Department or in some other manner;
 - ii. on a periodical basis such cases are consolidated and a centralized list or decentralized lists of such suppliers with the period of debarment is maintained and displayed on website(s);
 - iii. in respect of procuring entities other than the one which has carried out the debarment, the debarment takes effect prospectively from the date of uploading on the website(s) in the such a manner that ongoing procurements are not disrupted.

10. Specifications in Tenders and other procurement solicitations:

- a. Every procuring entity shall ensure that the eligibility conditions in respect of previous experience fixed in any tender or solicitation do not require proof of supply in other countries or proof of exports.
- b. Procuring entities shall endeavour to see that eligibility conditions, including on matters like turnover, production capability and financial strength do not result in unreasonable exclusion of 'Class-I local supplier'/ 'Class-II local supplier' who would otherwise be eligible, beyond what is essential for ensuring quality or creditworthiness of the supplier.
- c. Procuring entities shall, within 2 months of the issue of this Order review all existing eligibility norms and conditions with reference to sub-paragraphs 'a' and 'b' above.

.....Contd. p/6

- 6 -

- d. If a Nodal Ministry is satisfied that Indian suppliers of an item are not allowed to participate and/ or compete in procurement by any foreign government, it may, if it deems appropriate, restrict or exclude bidders from that country from eligibility for procurement of that item and/ or other items relating to that Nodal Ministry. A copy of every instruction or decision taken in this regard shall be sent to the Chairman of the Standing Committee.
- e. For the purpose of sub-paragraph 10 d above, a supplier or bidder shall be considered to be from a country if (i) the entity is incorporated in that country, or ii) a majority of its shareholding or effective control of the entity is exercised from that country; or (iii) more than 50% of the value of the item being supplied has been added in that country. Indian suppliers shall mean those entities which meet any of these tests with respect to India."

✓ **10A. Action for non-compliance of the Provisions of the Order:** In case restrictive or discriminatory conditions against domestic suppliers are included in bid documents, an inquiry shall be conducted by the Administrative Department undertaking the procurement (including procurement by any entity under its administrative control) to fix responsibility for the same. Thereafter, appropriate action, administrative or otherwise, shall be taken against erring officials of procurement entities under relevant provisions. Intimation on all such actions shall be sent to the Standing Committee.

11. Assessment of supply base by Nodal Ministries: The Nodal Ministry shall keep in view the domestic manufacturing / supply base and assess the available capacity and the extent of local competition while identifying items and prescribing minimum local content or the manner of its calculation, with a view to avoiding cost increase from the operation of this Order.

12. Increase in minimum local content: The Nodal Ministry may annually review the local content requirements with a view to increasing them, subject to availability of sufficient local competition with adequate quality.

13. Manufacture under license/ technology collaboration agreements with phased indigenization: While notifying the minimum local content, Nodal Ministries may make special provisions for exempting suppliers from meeting the stipulated local content if the product is being manufactured in India under a license from a foreign manufacturer who holds intellectual property rights and where there is a technology collaboration agreement / transfer of technology agreement for indigenous manufacture of a product developed abroad with clear phasing of increase in local content.

14. Powers to grant exemption and to reduce minimum local content: The administrative Department undertaking the procurement (including procurement by any entity under its administrative control), with the approval of their Minister-in-charge, may by written order, for reasons to be recorded in writing,

- a. reduce the minimum local content below the prescribed level; or
- b. reduce the margin of purchase preference below 20%; or

.....Contd. p/7

- c. exempt any particular item or supplying entities from the operation of this Order or any part of the Order.

A copy of every such order shall be provided to the Standing Committee and concerned Nodal Ministry / Department. The Nodal Ministry / Department concerned will continue to have the power to vary its notification on Minimum Local Content.

15. **Directions to Government companies:** In respect of Government companies and other procuring entities not governed by the General Financial Rules, the administrative Ministry or Department shall issue policy directions requiring compliance with this Order.

16. **Standing Committee:** A standing committee is hereby constituted with the following membership:

Secretary, Department for Promotion of Industry and Internal Trade—Chairman
Secretary, Commerce—Member
Secretary, Ministry of Electronics and Information Technology—Member
Joint Secretary (Public Procurement), Department of Expenditure—Member
Joint Secretary (DPIIT)—Member-Convenor

The Secretary of the Department concerned with a particular item shall be a member in respect of issues relating to such item. The Chairman of the Committee may co-opt technical experts as relevant to any issue or class of issues under its consideration.

17. **Functions of the Standing Committee:** The Standing Committee shall meet as often as necessary, but not less than once in six months. The Committee

- a. shall oversee the implementation of this order and issues arising therefrom, and make recommendations to Nodal Ministries and procuring entities.
- b. shall annually assess and periodically monitor compliance with this Order
- c. shall identify Nodal Ministries and the allocation of items among them for issue of notifications on minimum local content
- d. may require furnishing of details or returns regarding compliance with this Order and related matters
- e. may, during the annual review or otherwise, assess issues, if any, where it is felt that the manner of implementation of the order results in any restrictive practices, cartelization or increase in public expenditure and suggest remedial measures
- f. may examine cases covered by paragraph 13 above relating to manufacture under license/ technology transfer agreements with a view to satisfying itself that adequate mechanisms exist for enforcement of such agreements and for attaining the underlying objective of progressive indigenization
- g. may consider any other issue relating to this Order which may arise.

18. **Removal of difficulties:** Ministries /Departments and the Boards of Directors of Government companies may issue such clarifications and instructions as may be necessary for the removal of any difficulties arising in the implementation of this Order.

.....Contd. p/8

19. **Ministries having existing policies:** Where any Ministry or Department has its own policy for preference to local content approved by the Cabinet after 1st January 2015, such policies will prevail over the provisions of this Order. All other existing orders on preference to local content shall be reviewed by the Nodal Ministries and revised as needed to conform to this Order, within two months of the issue of this Order.

20. **Transitional provision:** This Order shall not apply to any tender or procurement for which notice inviting tender or other form of procurement solicitation has been issued before the issue of this Order.



(Rajesh Gupta)
Director

Tel: 23063211

rajesh.gupta66@gov.in

1832359/2023/HEP-MNX35400

No. P-45021/2/2017-PP (BE-II)

Government of India
Ministry of Commerce and Industry
Department for Promotion of Industry and Internal Trade
(Public Procurement Section)

Udyog Bhawan, New Delhi
Dated: 16th September, 2020

To

All Central Ministries/Departments/CPSUs/All concerned

ORDER

Subject: Public Procurement (Preference to Make in India), Order 2017– Revision; regarding.

Department for Promotion of Industry and Internal Trade, in partial modification [Paras 2, 3, 5, 10 & 13] of Order No.P-45021/2/2017-B.E.-II dated 15.6.2017 as amended by Order No.P-45021/2/2017-B.E.-II dated 28.05.2018, Order No.P-45021/2/2017-B.E.-II dated 29.05.2019 and Order No.P-45021/2/2017-B.E.-II dated 04.06.2020, hereby issues the revised 'Public Procurement (Preference to Make in India), Order 2017' dated 16.09.2020 effective with immediate effect.

Whereas it is the policy of the Government of India to encourage 'Make in India' and promote manufacturing and production of goods and services in India with a view to enhancing income and employment, and

Whereas procurement by the Government is substantial in amount and can contribute towards this policy objective, and

Whereas local content can be increased through partnerships, cooperation with local companies, establishing production units in India or Joint Ventures (JV) with Indian suppliers, increasing the participation of local employees in services and training them,

Now therefore the following Order is issued:

1. This Order is issued pursuant to Rule 153 (iii) of the General Financial Rules 2017.
2. **Definitions:** For the purposes of this Order:

'Local content' means the amount of value added in India which shall, unless otherwise prescribed by the Nodal Ministry, be the total value of the item procured (excluding net domestic indirect taxes) minus the value of imported content in the item (including all customs duties) as a proportion of the total value, in percent.

'Class-I local supplier' means a supplier or service provider, whose goods, services or works offered for procurement, meets the minimum local content as prescribed for 'Class-I local supplier' under this Order.

.....Contd. p/2

'Class-II local supplier' means a supplier or service provider, whose goods, services or works offered for procurement, meets the minimum local content as prescribed for 'Class-II local supplier' but less than that prescribed for 'Class-I local supplier' under this Order.

'Non - Local supplier' means a supplier or service provider, whose goods, services or works offered for procurement, has local content less than that prescribed for 'Class-II local supplier' under this Order.

'L1' means the lowest tender or lowest bid or the lowest quotation received in a tender, bidding process or other procurement solicitation as adjudged in the evaluation process as per the tender or other procurement solicitation.

'Margin of purchase preference' means the maximum extent to which the price quoted by a "Class-I local supplier" may be above the L1 for the purpose of purchase preference.

'Nodal Ministry' means the Ministry or Department identified pursuant to this order in respect of a particular item of goods or services or works.

'Procuring entity' means a Ministry or department or attached or subordinate office of, or autonomous body controlled by, the Government of India and includes Government companies as defined in the Companies Act.

'Works' means all works as per Rule 130 of GFR- 2017, and will also include 'turnkey works'.

3. Eligibility of 'Class-I local supplier' / 'Class-II local supplier' / 'Non-local suppliers' for different types of procurement

(a) In procurement of all goods, services or works in respect of which the Nodal Ministry / Department has communicated that there is sufficient local capacity and local competition, only 'Class-I local supplier', as defined under the Order, shall be eligible to bid irrespective of purchase value.

(b) Only 'Class-I local supplier' and 'Class-II local supplier', as defined under the Order, shall be eligible to bid in procurements undertaken by procuring entities, except when Global tender enquiry has been issued. In global tender enquiries, 'Non-local suppliers' shall also be eligible to bid along with 'Class-I local suppliers' and 'Class-II local suppliers'. In procurement of all goods, services or works, not covered by sub-para 3(a) above, and with estimated value of purchases less than Rs. 200 Crore, in accordance with Rule 161(iv) of GFR, 2017, Global tender enquiry shall not be issued except with the approval of competent authority as designated by Department of Expenditure.

(c) For the purpose of this Order, works includes Engineering, Procurement and Construction (EPC) contracts and services include System Integrator (SI) contracts.

.....Contd. p/3

3A. Purchase Preference

(a) Subject to the provisions of this Order and to any specific instructions issued by the Nodal Ministry or in pursuance of this Order, purchase preference shall be given to 'Class-I local supplier' in procurements undertaken by procuring entities in the manner specified here under.

(b) In the procurements of goods or works, which are covered by para 3(b) above and which are divisible in nature, the 'Class-I local supplier' shall get purchase preference over 'Class-II local supplier' as well as 'Non-local supplier', as per following procedure:

- i. Among all qualified bids, the lowest bid will be termed as L1. If L1 is 'Class-I local supplier', the contract for full quantity will be awarded to L1.
- ii. If L1 bid is not a 'Class-I local supplier', 50% of the order quantity shall be awarded to L1. Thereafter, the lowest bidder among the 'Class-I local supplier' will be invited to match the L1 price for the remaining 50% quantity subject to the Class-I local supplier's quoted price falling within the margin of purchase preference, and contract for that quantity shall be awarded to such 'Class-I local supplier' subject to matching the L1 price. In case such lowest eligible 'Class-I local supplier' fails to match the L1 price or accepts less than the offered quantity, the next higher 'Class-I local supplier' within the margin of purchase preference shall be invited to match the L1 price for remaining quantity and so on, and contract shall be awarded accordingly. In case some quantity is still left uncovered on Class-I local suppliers, then such balance quantity may also be ordered on the L1 bidder.

(c) In the procurements of goods or works, which are covered by para 3(b) above and which are not divisible in nature, and in procurement of services where the bid is evaluated on price alone, the 'Class-I local supplier' shall get purchase preference over 'Class-II local supplier' as well as 'Non-local supplier', as per following procedure:

- i. Among all qualified bids, the lowest bid will be termed as L1. If L1 is 'Class-I local supplier', the contract will be awarded to L1.
- ii. If L1 is not 'Class-I local supplier', the lowest bidder among the 'Class-I local supplier', will be invited to match the L1 price subject to Class-I local supplier's quoted price falling within the margin of purchase preference, and the contract shall be awarded to such 'Class-I local supplier' subject to matching the L1 price.
- iii. In case such lowest eligible 'Class-I local supplier' fails to match the L1 price, the 'Class-I local supplier' with the next higher bid within the margin of purchase preference shall be invited to match the L1 price and so on and contract shall be awarded accordingly. In case none of the 'Class-I local supplier' within the margin of purchase preference matches the L1 price, the contract may be awarded to the L1 bidder.

- (d) "Class-II local supplier" will not get purchase preference in any procurement, undertaken by procuring entities.

3B. Applicability in tenders where contract is to be awarded to multiple bidders -

In tenders where contract is awarded to multiple bidders subject to matching of L1 rates or otherwise, the 'Class-I local supplier' shall get purchase preference over 'Class-II local supplier' as well as 'Non-local supplier', as per following procedure:

- a) In case there is sufficient local capacity and competition for the item to be procured, as notified by the nodal Ministry, only Class I local suppliers shall be eligible to bid. As such, the multiple suppliers, who would be awarded the contract, should be all and only 'Class I Local suppliers'.
- b) In other cases, 'Class II local suppliers' and 'Non local suppliers' may also participate in the bidding process along with 'Class I Local suppliers' as per provisions of this Order.
- c) If 'Class I Local suppliers' qualify for award of contract for at least 50% of the tendered quantity in any tender, the contract may be awarded to all the qualified bidders as per award criteria stipulated in the bid documents. However, in case 'Class I Local suppliers' do not qualify for award of contract for at least 50% of the tendered quantity, purchase preference should be given to the 'Class I local supplier' over 'Class II local suppliers'/'Non local suppliers' provided that their quoted rate falls within 20% margin of purchase preference of the highest quoted bidder considered for award of contract so as to ensure that the 'Class I Local suppliers' taken in totality are considered for award of contract for at least 50% of the tendered quantity.
- d) First purchase preference has to be given to the lowest quoting 'Class-I local supplier', whose quoted rates fall within 20% margin of purchase preference, subject to its meeting the prescribed criteria for award of contract as also the constraint of maximum quantity that can be sourced from any single supplier. If the lowest quoting 'Class-I local supplier', does not qualify for purchase preference because of aforesaid constraints or does not accept the offered quantity, an opportunity may be given to next higher 'Class-I local supplier', falling within 20% margin of purchase preference, and so on.
- e) To avoid any ambiguity during bid evaluation process, the procuring entities may stipulate its own tender specific criteria for award of contract amongst different bidders including the procedure for purchase preference to 'Class-I local supplier' within the broad policy guidelines stipulated in sub-paras above.

4. **Exemption of small purchases:** Notwithstanding anything contained in paragraph 3, procurements where the estimated value to be procured is less than Rs. 5 lakhs shall be exempt from this Order. However, it shall be ensured by procuring entities that procurement is not split for the purpose of avoiding the provisions of this Order.

5. **Minimum local content:** The 'local content' requirement to categorize a supplier as 'Class-I local supplier' is minimum 50%. For 'Class-II local supplier', the 'local content' requirement is minimum 20%. Nodal Ministry/ Department may prescribe only a higher

percentage of minimum local content requirement to categorize a supplier as 'Class-I local supplier'/ 'Class-II local supplier'. For the items, for which Nodal Ministry/ Department has not prescribed higher minimum local content notification under the Order, it shall be 50% and 20% for 'Class-I local supplier'/ 'Class-II local supplier' respectively.

6. **Margin of Purchase Preference:** The margin of purchase preference shall be 20%.
7. **Requirement for specification in advance:** The minimum local content, the margin of purchase preference and the procedure for preference to Make in India shall be specified in the notice inviting tenders or other form of procurement solicitation and shall not be varied during a particular procurement transaction.
8. **Government E-marketplace:** In respect of procurement through the Government E-marketplace (GeM) shall, as far as possible, specifically mark the items which meet the minimum local content while registering the item for display, and shall, wherever feasible, make provision for automated comparison with purchase preference and without purchase preference and for obtaining consent of the local supplier in those cases where purchase preference is to be exercised.
9. **Verification of local content:**
 - a. The 'Class-I local supplier'/ 'Class-II local supplier' at the time of tender, bidding or solicitation shall be required to indicate percentage of local content and provide self-certification that the item offered meets the local content requirement for 'Class-I local supplier'/ 'Class-II local supplier', as the case may be. They shall also give details of the location(s) at which the local value addition is made.
 - b. In cases of procurement for a value in excess of Rs. 10 crores, the 'Class-I local supplier'/ 'Class-II local supplier' shall be required to provide a certificate from the statutory auditor or cost auditor of the company (in the case of companies) or from a practicing cost accountant or practicing chartered accountant (in respect of suppliers other than companies) giving the percentage of local content.
 - c. Decisions on complaints relating to implementation of this Order shall be taken by the competent authority which is empowered to look into procurement-related complaints relating to the procuring entity.
 - d. Nodal Ministries may constitute committees with internal and external experts for independent verification of self-declarations and auditor's/ accountant's certificates on random basis and in the case of complaints.
 - e. Nodal Ministries and procuring entities may prescribe fees for such complaints.
 - f. False declarations will be in breach of the Code of Integrity under Rule 175(1)(i)(h) of the General Financial Rules for which a bidder or its successors can be debarred for up to two years as per Rule 151 (iii) of the General Financial Rules along with such other actions as may be permissible under law.

.....Contd. p/6

- g. A supplier who has been debarred by any procuring entity for violation of this Order shall not be eligible for preference under this Order for procurement by any other procuring entity for the duration of the debarment. The debarment for such other procuring entities shall take effect prospectively from the date on which it comes to the notice of other procurement entities, in the manner prescribed under paragraph 9h below.
- h. The Department of Expenditure shall issue suitable instructions for the effective and smooth operation of this process, so that:
- i. The fact and duration of debarment for violation of this Order by any procuring entity are promptly brought to the notice of the Member-Convenor of the Standing Committee and the Department of Expenditure through the concerned Ministry /Department or in some other manner;
 - ii. on a periodical basis such cases are consolidated and a centralized list or decentralized lists of such suppliers with the period of debarment is maintained and displayed on website(s);
 - iii. in respect of procuring entities other than the one which has carried out the debarment, the debarment takes effect prospectively from the date of uploading on the website(s) in the such a manner that ongoing procurements are not disrupted.

10. **Specifications in Tenders and other procurement solicitations:**

- a. Every procuring entity shall ensure that the eligibility conditions in respect of previous experience fixed in any tender or solicitation do not require proof of supply in other countries or proof of exports.
- b. Procuring entities shall endeavour to see that eligibility conditions, including on matters like turnover, production capability and financial strength do not result in unreasonable exclusion of 'Class-I local supplier'/ 'Class-II local supplier' who would otherwise be eligible, beyond what is essential for ensuring quality or creditworthiness of the supplier.
- c. Procuring entities shall, within 2 months of the issue of this Order review all existing eligibility norms and conditions with reference to sub-paragraphs 'a' and 'b' above.

d. Reciprocity Clause

- i. When a Nodal Ministry/Department identifies that Indian suppliers of an item are not allowed to participate and/ or compete in procurement by any foreign government, due to restrictive tender conditions which have direct or indirect effect of barring Indian companies such as registration in the procuring country, execution of projects of specific value in the procuring country etc., it shall provide such details to all its procuring entities including CMDs/CEOs of PSEs/PSUs, State Governments and other procurement agencies under their administrative control and GeM for appropriate reciprocal action.

- 7 -

- ii. Entities of countries which have been identified by the nodal Ministry/Department as not allowing Indian companies to participate in their Government procurement for any item related to that nodal Ministry shall not be allowed to participate in Government procurement in India for all items related to that nodal Ministry/ Department, except for the list of items published by the Ministry/ Department permitting their participation.
 - iii. The stipulation in (ii) above shall be part of all tenders invited by the Central Government procuring entities stated in (i) above. All purchases on GeM shall also necessarily have the above provisions for items identified by nodal Ministry/ Department.
 - iv. State Governments should be encouraged to incorporate similar provisions in their respective tenders.
 - v. The term 'entity' of a country shall have the same meaning as under the FDI Policy of DPIIT as amended from time to time.
- e. Specifying foreign certifications/ unreasonable technical specifications/ brands/ models in the bid document is restrictive and discriminatory practice against local suppliers. If foreign certification is required to be stipulated because of non-availability of Indian Standards and/or for any other reason, the same shall be done only after written approval of Secretary of the Department concerned or any other Authority having been designated such power by the Secretary of the Department concerned.
- f. "All administrative Ministries/Departments whose procurement exceeds Rs. 1000 Crore per annum shall notify/ update their procurement projections every year, including those of the PSEs/PSUs, for the next 5 years on their respective website."

10A. Action for non-compliance of the Provisions of the Order: In case restrictive or discriminatory conditions against domestic suppliers are included in bid documents, an inquiry shall be conducted by the Administrative Department undertaking the procurement (including procurement by any entity under its administrative control) to fix responsibility for the same. Thereafter, appropriate action, administrative or otherwise, shall be taken against erring officials of procurement entities under relevant provisions. Intimation on all such actions shall be sent to the Standing Committee.

11. Assessment of supply base by Nodal Ministries: The Nodal Ministry shall keep in view the domestic manufacturing / supply base and assess the available capacity and the extent of local competition while identifying items and prescribing the higher minimum local content or the manner of its calculation, with a view to avoiding cost increase from the operation of this Order.

12. Increase in minimum local content: The Nodal Ministry may annually review the local content requirements with a view to increasing them, subject to availability of sufficient local competition with adequate quality.

.....Contd. p/8

13. **Manufacture under license/ technology collaboration agreements with phased indigenization:** While notifying the minimum local content, Nodal Ministries may make special provisions for exempting suppliers from meeting the stipulated local content if the product is being manufactured in India under a license from a foreign manufacturer who holds intellectual property rights and where there is a technology collaboration agreement / transfer of technology agreement for indigenous manufacture of a product developed abroad with clear phasing of increase in local content.

13A. In procurement of all goods, services or works in respect of which there is substantial quantity of public procurement and for which the nodal ministry has not notified that there is sufficient local capacity and local competition, the concerned nodal ministry shall notify an upper threshold value of procurement beyond which foreign companies shall enter into a joint venture with an Indian company to participate in the tender. Procuring entities, while procuring such items beyond the notified threshold value, shall prescribe in their respective tenders that foreign companies may enter into a joint venture with an Indian company to participate in the tender. The procuring Ministries/Departments shall also make special provisions for exempting such joint ventures from meeting the stipulated minimum local content requirement, which shall be increased in a phased manner.

14. **Powers to grant exemption and to reduce minimum local content:** The administrative Department undertaking the procurement (including procurement by any entity under its administrative control), with the approval of their Minister-in-charge, may by written order, for reasons to be recorded in writing,

- a. reduce the minimum local content below the prescribed level; or
- b. reduce the margin of purchase preference below 20%; or
- c. exempt any particular item or supplying entities from the operation of this Order or any part of the Order.

A copy of every such order shall be provided to the Standing Committee and concerned Nodal Ministry / Department. The Nodal Ministry / Department concerned will continue to have the power to vary its notification on Minimum Local Content.

15. **Directions to Government companies:** In respect of Government companies and other procuring entities not governed by the General Financial Rules, the administrative Ministry or Department shall issue policy directions requiring compliance with this Order.

16. **Standing Committee:** A standing committee is hereby constituted with the following membership:

Secretary, Department for Promotion of Industry and Internal Trade—Chairman
 Secretary, Commerce—Member
 Secretary, Ministry of Electronics and Information Technology—Member
 Joint Secretary (Public Procurement), Department of Expenditure—Member
 Joint Secretary (DPIIT)—Member-Convenor

The Secretary of the Department concerned with a particular item shall be a member in respect of issues relating to such item. The Chairman of the Committee may co-opt technical experts as relevant to any issue or class of issues under its consideration.

17. Functions of the Standing Committee: The Standing Committee shall meet as often as necessary, but not less than once in six months. The Committee

- a. shall oversee the implementation of this order and issues arising therefrom, and make recommendations to Nodal Ministries and procuring entities.
- b. shall annually assess and periodically monitor compliance with this Order
- c. shall identify Nodal Ministries and the allocation of items among them for issue of notifications on minimum local content
- d. may require furnishing of details or returns regarding compliance with this Order and related matters
- e. may, during the annual review or otherwise, assess issues, if any, where it is felt that the manner of implementation of the order results in any restrictive practices, cartelization or increase in public expenditure and suggest remedial measures
- f. may examine cases covered by paragraph 13 above relating to manufacture under license/ technology transfer agreements with a view to satisfying itself that adequate mechanisms exist for enforcement of such agreements and for attaining the underlying objective of progressive indigenization
- g. may consider any other issue relating to this Order which may arise.

18. Removal of difficulties: Ministries /Departments and the Boards of Directors of Government companies may issue such clarifications and instructions as may be necessary for the removal of any difficulties arising in the implementation of this Order.

19. Ministries having existing policies: Where any Ministry or Department has its own policy for preference to local content approved by the Cabinet after 1st January 2015, such policies will prevail over the provisions of this Order. All other existing orders on preference to local content shall be reviewed by the Nodal Ministries and revised as needed to conform to this Order, within two months of the issue of this Order.

20. Transitional provision: This Order shall not apply to any tender or procurement for which notice inviting tender or other form of procurement solicitation has been issued before the issue of this Order.

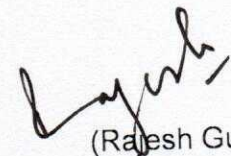

(Rajesh Gupta)
Director

Tel: 23063211

rajesh.gupta66@gov.in

 ENQUIRY TWO PART BID E-TENDER BPC 0007	भारत हेवी इलेक्ट्रिकल्स लिमिटेड, पिपलानी, भोपाल- ४६२०२२ (भारत) सामग्री प्रबंधन विभाग BHARAT HEAVY ELECTRICALS LIMITED, PIPLANI, BHOPAL-462022 (INDIA) MATERIALS MANAGEMENT DIVISION	ENQUIRY NO E5133136 ENQUIRY DATE 14/12/23 ENQUIRY DUE DATE 05/01/24
TIN NO- 23573000001 ECC NO- AAACB4146PKM009 MPCT NO- HEL/05/01/0001/S15/11/179 PHONE NO : 91-755-2500100 FAX : 91-755-2500023 www.bhel.com		

SUPP NAME AND ADDRESS	SUPP CODE	REV CD	REV NO	REV DATE	NO OF CATY2	NO OF CATY3	ENQ NO OF ITEMS	INDENT NO
OFFICE COPY		1	0	NA	1	9	1	120533075
	GUARANTEE CERTIFICATE	Y		SUPPLY CONDITION	IDENTIFICATION MUST			
	TEST CERTIFICATE	Y		TECHNICAL CONDITION	AS PER PI			
	INSTRUCTION BOOKLET	N		INSPECTION CONDITION	BY BHEL AUTHORIZED TPIA AT VENDOR'S WORKS			
	SAMPLE	N						
GATE PASS	Y							

NOTE: QUOTE PRICE BOTH IN FIGURES & WORDS, IN CASE OF MISMATCH PRICE IN WORDS WILL BE VALID, QUOTATIONS NOT BEARING ENQUIRY NO AND DUE DATE LIABLE TO BE REJECTED.

SL NO	MATERIAL CODE	DESC	UNIT	ITEM QTY	QTY VR%	LOT NO	LOT QTY	DEST	DELIVERY DATE
1	BP9044875302	SHORT CIRCUIT RING DE & NDE AS PER DRG NO.34454505051 REV.02. (QAP NO:- QAP/ QTM/ VENDOR QAP/ 2022-23/ SHORT CIRCUIT (SC) RING REV 00 DTD 10/03/2023).	NO	2048.000	30	1	128.000	205	15/03/24
						2	256.000	205	15/05/24
						3	256.000	205	15/07/24
						4	256.000	205	15/09/24
						5	256.000	205	15/11/24
						6	256.000	205	15/01/25
						7	256.000	205	15/03/25
						8	256.000	205	15/05/25
						9	128.000	205	15/07/25

REMARK RATE CONTRACT IS PROPOSED TO BE FINALIZED ON TWO SOURCES. PREFERRED CUMULATIVE DELIVERY SHALL BE WITHIN 90 DAYS FOR 1ST LOT OF 128 NOS (CUMULATIVE REFERS TO QUANTITY FROM BOTH VENDORS I.E. 83 NOS AND 45 NOS FROM L-1 VENDOR AND VENDOR ACCEPTING L-1 PRICE RESPECTIVELY OR ENTIRE 128 NOS FROM SINGLE VENDOR AS PER RESPECTIVE PROPORTION OF QUANTITY ALLOTTED) FROM DATE OF PLACEMENT OF PO, THEREAFTER EACH SUBSEQUENT LOT OF 256 NOS (CUMULATIVE REFERS TO QUANTITY FROM BOTH VENDORS I.E. 166 NOS AND 90 NOS FROM L-1 VENDOR AND VENDOR ACCEPTING L-1 PRICE RESPECTIVELY OR ENTIRE 256 NOS FROM SINGLE VENDOR AS PER RESPECTIVE PROPORTION OF QUANTITY ALLOTTED) WITHIN NEXT 60 DAYS FROM EARLIER LOT. RC TO BE KEPT VALID FOR 24 MONTHS FROM DATE OF FREEZING OF RC FOR ORDERING. QUANTITY VARIATION WILL BE +30%.

DRAWING	PURCH SPEC	CATALOUGE	PLAN	TWO PART BID
Y	Y	N	Y	Y

SUPP CD.	SUPP NAME	MSME	STATUS	PMD	Cust Appr

NOTE: BHEL, BHOPAL'S Standard Terms & Conditions BP200102 (Latest Revision) form a part of this Enquiry. Bidders may obtain from us copies of these terms and conditions if not already available.

SPECIAL REMARKS: Bid to be submitted through e-procurement. Refer eproc link on BHEL Bhopal B2B site.	NAME : SHRI DEEPPENDRA PANDEY DESG : DY.MANAGER 0755-2505014 dpandey@bhel.in
SIGN & SEAL	



ENQUIRY
TWO PART BID
E-TENDER
BPC 0007

भारत हेवी इलेक्ट्रिकल्स लिमिटेड, पिपलानी, भोपाल- ४६२०२२ (भारत)
सामग्री प्रबंधन विभाग
BHARAT HEAVY ELECTRICALS LIMITED, PIPLANI, BHOPAL-462022 (INDIA)
MATERIALS MANAGEMENT DIVISION

TIN NO- 23573000001 ECC NO- AAACB4146PKM009 MPCT NO- HEL/05/01/0001/S15/11/79
 PHONE NO : 91-755-2500100 FAX : 91-755-2500023 www.bhel.com

ENQUIRY NO E5133136
 ENQUIRY DATE 14/12/23
 ENQUIRY DUE DATE 05/01/24

S.NO	INDENT NO	ITEM NO	CATEGORY	ENQUIRY QTY.
1	120533075	1	120350	2048.000

NOTE: BHEL, BHOPAL'S Standard Terms & Conditions BP200102 (Latest Revision) form a part of this Enquiry. Bidders may obtain from us copies of these terms and conditions if not already available.

SPECIAL REMARKS: Bid to be submitted through e-procurement. Refer eproc link on BHEL Bhopal B2B site.

NAME : SHRI DEEPENDRA PANDEY
DESG : DY.MANAGER
 0755-2505014
 dpandey@bhel.in
SIGN & SEAL

INTEGRITY PACT**Between**

Bharat Heavy Electricals Ltd. (BHEL), a company registered under the Companies Act 1956 and having its registered office at "BHEL House", Siri Fort, New Delhi - 110049 (India) hereinafter referred to as "The Principal", which expression unless repugnant to the context or meaning hereof shall include its successors or assigns of the ONE PART

and

_____, (description of the party along with address), hereinafter referred to as "The Bidder/ Contractor" which expression unless repugnant to the context or meaning hereof shall include its successors or assigns of the OTHER PART

Preamble

The Principal intends to award, under laid-down organizational procedures, contract/s for Tender
E 5133136 (Short Circuit Ring)
_____ (hereinafter referred to as "Contract"). The Principal values full compliance with all relevant laws of the land, rules and regulations, and the principles of economic use of resources, and of fairness and transparency in its relations with its Bidder(s)/ Contractor(s).

In order to achieve these goals, the Principal will appoint panel of Independent External Monitor(s) (IEMs), who will monitor the tender process and the execution of the contract for compliance with the principles mentioned above.

Section 1- Commitments of the Principal

- 1.1 The Principal commits itself to take all measures necessary to prevent corruption and to observe the following principles: -
 - 1.1.1 No employee of the Principal, personally or through family members, will in connection with the tender for, or the execution of a contract, demand, take a promise for or accept, for self or third person, any material or immaterial benefit which the person is not legally entitled to.
 - 1.1.2 The Principal will, during the tender process treat all Bidder(s) with equity and reason. The Principal will in particular, before and during the tender process, provide to all Bidder(s) the same information and will not provide to any Bidder(s) confidential/ additional information through which the Bidder(s) could obtain an advantage in relation to the tender process or the contract execution.
 - 1.1.3 The Principal will exclude from the process all known prejudiced persons.
- 1.2 If the Principal obtains information on the conduct of any of its employees which is a penal offence under the Indian Penal Code 1860 and Prevention of Corruption Act 1988 or any other statutory penal enactment, or if there be a substantive suspicion in this regard, the Principal will inform its Vigilance Office and in addition can initiate disciplinary actions.

Section 2 - Commitments of the Bidder(s)/ Contractor(s)

- 2.1 The Bidder(s)/ Contractor(s) commit himself to take all measures necessary to prevent corruption. The Bidder(s)/ Contractor(s) commits himself to observe the following principles during participation in the tender process and during the contract execution.

- 2.1.1 The Bidder(s)/ Contractor(s) will not, directly or through any other person or firm, offer, promise or give to the Principal or to any of the Principal's employees involved in the tender process or the execution of the contract or to any third person any material, immaterial or any other benefit which he/ she is not legally entitled to, in order to obtain in exchange any advantage of any kind whatsoever during the tender process or during the execution of the contract.
- 2.1.2 The Bidder(s)/ Contractor(s) will not enter with other Bidder(s) into any illegal or undisclosed agreement or understanding, whether formal or informal. This applies in particular to prices, specifications, certifications, subsidiary contracts, submission or non-submission of bids or any other actions to restrict competitiveness or to introduce cartelization in the bidding process.
- 2.1.3 The Bidder(s)/ Contractor(s) will not commit any penal offence under the relevant Indian Penal Code (IPC) and Prevention of Corruption Act; further the Bidder(s)/ Contractor(s) will not use improperly, for purposes of competition or personal gain, or pass on to others, any information or document provided by the Principal as part of the business relationship, regarding plans, technical proposals and business details, including information contained or transmitted electronically.
- 2.1.4 Foreign Bidder(s)/ Contractor(s) shall disclose the name and address of agents and representatives in India and Indian Bidder(s)/ Contractor(s) to disclose their foreign principals or associates. The Bidder(s)/ Contractor(s) will, when presenting his bid, disclose any and all payments he has made, and is committed to or intends to make to agents, brokers or any other intermediaries in connection with the award of the contract.
- 2.2 The Bidder(s)/ Contractor(s) will not instigate third persons to commit offences outlined above or be an accessory to such offences.
- 2.3 The Bidder(s)/ Contractor(s) shall not approach the Courts while representing the matters to IEMs and shall await their decision in the matter.

Section 3 - Disqualification from tender process and exclusion from future contracts

If the Bidder(s)/ Contractor(s), before award or during execution has committed a transgression through a violation of Section 2 above, or acts in any other manner such as to put his reliability or credibility in question, the Principal is entitled to disqualify the Bidder(s)/ Contractor(s) from the tender process, terminate the contract, if already awarded, exclude from future business dealings and/ or take action as per the separate "Guidelines on Banning of Business dealings with Suppliers/ Contractors", framed by the Principal.

Section 4 - Compensation for Damages

- 4.1 If the Principal has disqualified the Bidder (s) from the tender process before award / order acceptance according to Section 3, the Principal is entitled to demand and recover the damages equivalent to Earnest Money Deposit/ Bid Security.
- 4.2 If the Principal is entitled to terminate the Contract according to Section 3, or terminates the Contract in application of Section 3 above, the Bidder(s)/ Contractor (s) transgression through a violation of Section 2 above shall be construed breach of contract and the Principal shall be entitled to demand and recover from the Contractor an amount equal to 5% of the contract value or the amount equivalent to Security Deposit/ Performance Bank Guarantee, whichever is higher, as damages, in addition to and without prejudice to its right to demand and recover compensation for any other loss or damages specified elsewhere in the contract.

Section 5 - Previous Transgression

- 5.1 The Bidder declares that no previous transgressions occurred in the last 3 (three) years with any other company in any country conforming to the anti-corruption approach or with any other Public Sector Enterprise in India that could justify his exclusion from the tender process.
- 5.2 If the Bidder makes incorrect statement on this subject, he can be disqualified from the tender process or the contract, if already awarded, can be terminated for such reason or action can be taken as per the separate "Guidelines on Banning of Business dealings with Suppliers/ Contractors", framed by the Principal.

Section 6 - Equal treatment of all Bidder (s)/ Contractor (s) / Sub-contractor (s)

- 6.1 The Principal will enter into Integrity Pacts with identical conditions as this Integrity Pact with all Bidders and Contractors.
- 6.2 In case of Sub-contracting, the Principal Contractor shall take the responsibility of the adoption of Integrity Pact by the Sub-contractor(s) and ensure that all Sub-contractors also sign the Integrity Pact.
- 6.3 The Principal will disqualify from the tender process all Bidders who do not sign this Integrity Pact or violate its provisions.

Section 7 - Criminal Charges against violating Bidders/ Contractors /Subcontractors

If the Principal obtains knowledge of conduct of a Bidder, Contractor or Subcontractor, or of an employee or a representative or an associate of a Bidder, Contractor or Subcontractor which constitutes corruption, or if the Principal has substantive suspicion in this regard, the Principal will inform the Vigilance Office.

Section 8 -Independent External Monitor(s)

- 8.1 The Principal appoints competent and credible panel of Independent External Monitor (s) (IEMs) for this Integrity Pact. The task of the IEMs is to review independently and objectively, whether and to what extent the parties comply with the obligations under this Integrity Pact.
- 8.2 The IEMs are not subject to instructions by the representatives of the parties and performs his functions neutrally and independently. He reports to the CMD, BHEL.
- 8.3 The IEMs shall be provided access to all documents/ records pertaining to the Contract, for which a complaint or issue is raised before them as and when warranted. However, the documents/records/information having National Security implications and those documents which have been classified as Secret/Top Secret are not to be disclosed.
- 8.4 The Principal will provide to the IEMs sufficient information about all meetings among the parties related to the Contract provided such meetings could have an impact on the contractual relations between the Principal and the Contractor. The parties offer to the IEMs the option to participate in such meetings.

- 8.5 The advisory role of IEMs is envisaged as that of a friend, philosopher and guide. The advice of IEMs would not be legally binding and it is restricted to resolving issues raised by a Bidder regarding any aspect of the tender which allegedly restricts competition or bias towards some Bidders. At the same time, it must be understood that IEMs are not consultants to the Management. Their role is independent in nature and the advice once tendered would not be subject to review at the request of the organization.
- 8.6 For ensuring the desired transparency and objectivity in dealing with the complaints arising out of any tendering process or during execution of Contract, the matter should be examined by the full panel of IEMs jointly, who would look into the records, conduct an investigation, and submit their joint recommendations to the Management.
- 8.7 The IEMs would examine all complaints received by them and give their recommendations/ views to the CMD, BHEL at the earliest. They may also send their report directly to the CVO, in case of suspicion of serious irregularities requiring legal/ administrative action. Only in case of very serious issue having a specific, verifiable Vigilance angle, the matter should be reported directly to the Commission. IEMs will tender their advice on the complaints within 30 days.
- 8.8 The CMD, BHEL shall decide the compensation to be paid to the IEMs and its terms and conditions.
- 8.9 IEMs should examine the process integrity, they are not expected to concern themselves with fixing of responsibility of officers. Complaints alleging mala fide on the part of any officer of the Principal should be looked into by the CVO of the Principal.
- 8.10 If the IEMs have reported to the CMD, BHEL, a substantiated suspicion of an offence under relevant Indian Penal Code / Prevention of Corruption Act, and the CMD, BHEL has not, within reasonable time, taken visible action to proceed against such offence or reported it to the Vigilance Office, the IEMs may also transmit this information directly to the Central Vigilance Commissioner, Government of India.
- 8.11 After award of work, the IEMs shall look into any issue relating to execution of Contract, if specifically raised before them. As an illustrative example, if a Contractor who has been awarded the Contract, during the execution of Contract, raises issue of delayed payment etc. before the IEMs, the same shall be examined by the panel of IEMs. Issues like warranty/ guarantee etc. shall be outside the purview of IEMs.
- 8.12 However, the IEMs may suggest systemic improvements to the management of the Principal, if considered necessary, to bring about transparency, equity and fairness in the system of procurement.
- 8.13 The word 'Monitor' would include both singular and plural.

Section 9 - Pact Duration

- 9.1 This Integrity Pact shall be operative from the date this Integrity Pact is signed by both the parties till the final completion of contract for successful Bidder, and for all other Bidders 6 months after the Contract has been awarded. Any violation of the same would entail disqualification of the bidders and exclusion from future business dealings.
- 9.2 If any claim is made/ lodged during currency of this Integrity Pact, the same shall be binding and continue to be valid despite the lapse of this Pact as specified above, unless it is discharged/ determined by the CMD, BHEL.

Section 10 - Other Provisions

- 10.1 This Integrity Pact is subject to Indian Laws and exclusive jurisdiction shall be of the competent Courts as indicated in the Tender or Contract, as the case may be.
- 10.2 Changes and supplements as well as termination notices need to be made in writing.
- 10.3 If the Bidder(s)/ Contractor(s) is a partnership or a consortium or a joint venture, this Integrity Pact shall be signed by all partners of the partnership or joint venture or all consortium members.
- 10.4 Should one or several provisions of this Integrity Pact turn out to be invalid, the remainder of this Integrity Pact remains valid. In this case, the parties will strive to come to an agreement to their original intentions.
- 10.5 Only those bidders / contractors who have entered into this Integrity Pact with the Principal would be competent to participate in the bidding. In other words, entering into this Integrity Pact would be a preliminary qualification.
- 10.6 In the event of any dispute between the Principal and Bidder(s)/ Contractor(s) relating to the Contract, in case, both the parties are agreeable, they may try to settle dispute through Mediation before the panel of IEMs in a time bound manner. In case, the dispute remains unresolved even after mediation by the panel of IEMs, either party may take further action as the terms & conditions of the Contract. The fees/expenses on dispute resolution through mediation shall be shared by both the parties. Further, the mediation proceedings shall be confidential in nature and the parties shall keep confidential all matters relating to the mediation proceedings including any settlement agreement arrived at between the parties as outcome of mediation. Any views expressed, suggestions, admissions or proposals etc. made by either party in the course of mediation shall not be relied upon or introduced as evidence in any further arbitral or judicial proceedings, whether or not such proceedings relate to the dispute that is the subject of mediation proceedings. Neither of the parties shall present IEMs as witness in any Alternative Dispute Resolution or judicial proceedings in respect of the dispute that was subject of mediation.

DP
 पाण्डेय / DEEPENDRA PANDEY
 उप प्रबंधक / Manager
 MM-TPTND Division
 एच.ई.एल., भोपाल / BHEL, BHOPAL

For & On behalf of the Principal
 (Office Seal)

Place Bhopal
 Date 14.12.23

Witness: 12/12/23
 (Name & Address) Manoj K. Dubey
MNX, BHEL Bhopal

For & On behalf of the Bidder/ Contractor
 (Office Seal)

Witness: _____
 (Name & Address) _____

COMPANY LETTER HEAD

ANNEXURE-M

Certification under Preference to **“MAKE IN INDIA” Policy**

CERTIFICATE

In line with Government Public Procurement Order No. P-45021/2/2017-BE-II, dated 15.06.2017, *as amended from time to time and as applicable on the date of submission of tender*, hereby certify that

M/s _____ (Bidder name)
is meeting the requirement of minimum Local Content as defined in above orders for the material against Tender Ref. No. _____

Actual percentage of the Local Content (in %): _____

ADDRESS of the location at which local value addition shall be made:

It is understood that false declarations will be in breach of the Code of Integrity under Rule 175(1)(i)(h) of the General Financial Rule (GFR) for which the bidder or its successors can be debarred for upto two years as per Rule 151(iii) of the General Financial Rules along with such other actions as may be permissible under law.

(Signature of Authorized Signatory
& Company Seal with Name)

Name: _____

Designation: _____

Address: _____

NOTE: In case the bid value more than Rs. 10 Crores, bidder shall necessarily submit certificate from Statutory Auditor or Cost Auditor (if the OEM is a Company) and Cost Accountant or Chartered Accountant (for OEMs other than Companies) as per the above Circular & NIT.

TENDER DETAILS**ENQUIRY NO. - E5133136, DUE ON 05-01-2024.**

Description: RATE CONTRACT FOR SHORT CIRCUIT RING DE & NDE AS PER DRG NO.34454505051 REV.02. (QAP NO:- QAP/ QTM/ VENDOR QAP/ 2022-23/ SHORT CIRCUIT (SC) RING REV 00 DTD 10/03/2023).

TENDER QTY.: 2048 NOs, +/- 30%

DELIVERY REQUIREMENT - Rate Contract is proposed to be finalized on two sources. Preferred cumulative delivery shall be within 90 days for 1st lot of 128 Nos (Cumulative refers to quantity from both vendors i.e. 83 Nos and 45 Nos from L-1 vendor and vendor accepting L-1 price respectively OR entire 128 Nos from single vendor as per respective proportion of quantity allotted) FROM DATE OF PLACEMENT OF PO, THEREAFTER EACH SUBSEQUENT LOT OF 256 Nos (Cumulative refers to quantity from both vendors i.e. 166 Nos and 90 Nos from L-1 vendor and vendor accepting L-1 price respectively OR entire 256 Nos from single vendor as per respective proportion of quantity allotted) WITHIN NEXT 60 DAYS FROM EARLIER LOT.

IT IS HEREBY MENTIONED THAT THIS IS E-TENDER SO OFFER SUBMITTED THROUGH E-PROCUREMENT PORTAL (www.eprocurebhel.co.in) SHALL ONLY BE CONSIDERED.

NOTE: ALL THE TERMS OF SUBJECT TENDER SHALL BE IN ACCORDANCE WITH "GENERAL TERMS AND CONDITIONS TO ENQUIRY BP 200102A". VENDORS ARE REQUIRED TO COMPLY AFORESAID ENQUIRY TERMS OF BHEL.

- 1) RATE CONTRACT TERMS:** WE INTEND TO ENTER INTO RATE CONTRACT FOR ORDERING UPTO 24 MONTHS FROM RC FREEZING DATE.
- 2) NO. OF BID PARTS:** 2 (TWO)
- 3) DELIVERY TERMS:** F.O.R. DESTINATION
- 4) DELIVERY AT:** CRX, BHEL, BHOPAL- 462022
- 5) VALIDITY OF OFFER:** 90 DAYS FROM TECHNICAL BID OPENING DATE
- 6) PRICE BASIS:** PVC APPLICABLE AS PER PVC Annexure (Bidder have to quote only firm basic fabrication rate in operated currency (INR) per Number (NO))
- 7) BHEL STANDARD PAYMENT TERMS:** 100% payment in 90 days of receipt (45 days for MSE including UDYAM registered suppliers as per relevant act in force), subject to acceptance of material and relevant documents at BHEL. PI refer GTC BP200102A
- 8) PENALTY:** APPLICABLE, AS PER ATTACHED GTC BP 200102A.
- 9) INSPECTION CONDITION:** BY BHEL AUTHORISED TPIA AT VENDOR'S WORKS
- 10) SUPPLY CONDITION:** IDENTIFICATION MUST
- 11) TECHNICAL CONDITION:** AS PER DRAWING, SPECIFICATION, TECH. PQR & QAP ETC ATTACHED
- 12) GUARANTEE CERTIFICATE:** YES
- 13) TEST CERTIFICATE:** YES
- 14) SAMPLE:** NO
- 15) TOOLS / GAUGES / FIXTURES CONDITION:** NA
- 16) EVALUATION CRITERIA:** ITEM WISE
- 17) SPLITTING OF ORDER:** YES

RATE CONTRACT TO BE FINALIZED ON TWO SOURCES WITH QUANTITY DISTRIBUTION RATIO OF 65% & 35% TO L-1 VENDOR AND THE OTHER BIDDER ACCEPTING L-1 RATES RESPECTIVELY, SUBJECT TO MINIMUM 3 QUALIFIED BIDDERS. FOR ASCERTAINING BIDDER FOR 35% QUANTITY, HESG EQUIVALENT RATES OF L-1 BIDDER WILL BE SEQUENTIALLY COUNTER-OFFERED TO L-2, L-3 AND SO ON BIDDER UNTILL

ANY BIDDER ACCEPTS THE SAME. IN CASE OF ONLY 2 QUALIFIED BIDDERS, BHEL RESERVES THE RIGHT FOR DISTRIBUTION BETWEEN 2 BIDDERS. IN CASE OF ONLY ONE QUALIFIED BIDDER OR IN CASE NO BIDDER AGREES TO ACCEPT THE COUNTEROFFERED HESG EQUIVALENT RATES OF L-1, BHEL MAY DECIDE TO AWARD ENTIRE 100% QUANTITY TO L-1 BIDDER. DISTRIBUTION IN COMPLIANCE WITH LATEST GUIDELINES FOR MSE AND MII WILL ALSO BE FOLLOWED FURTHER.

18) TENDER FEE: NOT APPLICABLE

19) REVERSE AUCTION: YES

It is declared upfront that Enquiry No. **E5133136** shall be subjected to Reverse Auction (RA). Bidders may kindly note the Reverse Auction (RA) field as mentioned and asked for in enquiry template & ensure to proceed with choosing "YES" against same when asked during submission of their offer to give their acceptance for participation in RA.

"BHEL shall be resorting to Reverse Auction (RA) (Guidelines as available on www.bhel.com) for this tender. RA shall be conducted among the techno- commercially qualified bidders.

Price bids of all techno-commercially qualified bidders shall be opened and same shall be considered for RA. In case any bidder(s) do(es) not participate in online Reverse Auction, their sealed envelope price bid along with applicable loading, if any, shall be considered for ranking."

20) EVALUATION CURRENCY: SHALL BE INR.

21) QTY. VARIATION: QTY. IS TENTATIVE & MAY VARY UPTO +/-30%

22) QAP: APPLICABLE AS PER ATTACHED QA PLAN.

23) ADDITIONAL TENDER REMARKS:

ENQUIRY IS FOR RATE CONTRACT WHICH IS TO BE KEPT VALID FOR ORDERING UPTO 24 MONTHS FROM RC FREEZING DATE FOR ORDERING. ORDERING WILL BE DONE AGAINST FIRM REQUIREMENT AS & WHEN NEEDED AND RC MAY BE CLOSED AT ANY TIME WITHOUT ASSIGNING REASONS WHATSOEVER IT MAY BE.

SUBMIT YOUR TENDER IN TWO PART BID BASIS.

ANNEXURE-IX OF NIT TO BE DULY FILLED / SIGNED & SHOULD FORM PART OF TECHNO-COMMERCIAL OFFER.

SPECIAL / GENERAL TERMS & CONDITIONS OF ENQUIRY, RA TERMS AND CONDITIONS AS PER NEW GUIDELINES, PQR ETC. ARE ENCLOSED.

INTEGRITY PACT FORMAT ATTACHED AS A PART OF NIT IS TO BE FOLLOWED AND COMPLIED WITH. DULY FILLED INTEGRITY PACT FORMAT SHALL BE SUBMITTED ALONG WITH THE OFFER.

UNREGISTERED VENDORS ARE REQUESTED TO SUBMIT THE REQUISITE DOCUMENTS FOR REGISTRATION BY BHEL ONLINE REGISTRATION PORTAL (<https://supplier.bhel.in>).

SPECIAL CONDITIONS OF NIT:

1. For this procurement, Public Procurement (Preference to Make in India) Order (PPP-MII Order), 2017 vide No. P-45021/2/2017-B.E.-II dated 15.06.2017, 28.05.2018, 29.05.2019 & 04.06.2020 and subsequent Orders issued by the respective Nodal Ministry shall be applicable even if issued after issue of this NIT but before finalization of contract / PO / WO against this NIT.

2. Technical Pre-Qualification Requirements (PQR) for procurement of Item: "SHORT CIRCUIT RING DE & NDE AS PER DRG NO.34454505051 REV.02. (QAP NO:- QAP/ QTM/ VENDOR QAP/ 2022-23/ SHORT CIRCUIT (SC) RING REV 00 DTD 10/03/2023)– 2048 NOs, +/- 30% is attached as a part of NIT. The same is to be followed and complied with. Duly filled PQR shall be submitted along with the offer along with desired documents as per PQR.

3. FINANCIAL PQR IS APPLICABLE: Average Turnover of last three years should be at least Rs 75 Lacs. Documents to be submitted by the vendor: Audited Statement of P & L accounts OR CA certificate of Turnover for FY 19-20, 20-21 and 21-22"

4. DULY FILLED INTEGRITY PACT FORMAT SHALL BE SUBMITTED ALONG WITH THE OFFER.

5. Offers of suppliers who are in 'Hold/Banned' status in BHEL Bhopal PMD shall not be considered.

6. Integrity Pact (IP)

(a) IP is a tool to ensure that activities and transactions between the Company and its Bidders / Contractors are handled in a fair, transparent and corruption free manner.

Following Independent External Monitors (IEMs) on the present panel have been appointed by BHEL with the approval of CVC to oversee implementation of IP in BHEL.

1. Shri Otem Dai, IAS (Retd.) - iem1@bhel.in

2. Shri Bishwamitra Pandey, IRAS (Retd.) – iem2@bhel.in

3. Shri Mukesh Mittal, IRS (Retd.) – iem3@bhel.in

(b) The IP as enclosed with the tender is to be submitted (duly signed by authorized signatory) along with techno-commercial bid (Part-I, in case of two/ three part bid). Only those bidders who have entered into such an IP with BHEL would be competent to participate in the bidding. In other words, entering into this Pact would be a preliminary qualification.

(c) Please refer Section-8 of IP for Role and Responsibilities of IEMs. In case of any complaint arising out of the tendering process, the matter may be referred to any of the above IEM(s). All correspondence with the IEMs shall be done through email only.

Note:

No routine correspondence shall be addressed to the IEM (phone / post/ email) regarding the clarifications, time extensions or any other administrative queries, etc on the tender issued. All such clarification/ issues shall be addressed directly to the tender issuing (procurement) department's officials whose contact details are provided below:

Details of contact person(s):

(1)

Name: Manoj Kumar Dubey [Engineer]

Deptt : MNX

Address: EW, GF, Annexe Block – 9,

BHEL, Bhopal - 462022

Phone: (Landline/ Mobile)

0755 – 2502379 / 8989802729

Email: manojdubey@bhel.in

(2)

Name: Deependra Pandey [Dy Manager]

1832359/2023/HEP-MNX35400

Deptt : MNX

Address: EW, GF, Annexe Block – 9,

BHEL, Bhopal - 462022

Phone: (Landline/ Mobile)

0755 – 2505014 / 9425018771

Email: dpandey@bhel.in

7. ANY DEVIATION OF GTC BP200102A (GENERAL TERMS & CONDITIONS OF ENQUIRY ATTACHED) WHERE VENDOR RESPONSE IS NOT AFFIRMATIVE TO BE CLEARLY INDICATED, ELSE BHEL WILL CONSIDER THAT ALL THE TERMS & CONDITIONS OF GTCBP200102 ARE ACCEPTABLE TO VENDORS.

8. IDENTIFICATION MUST AS PER TENDER TECHNICAL (DRAWING, SPECIFICATION ETC.) TERMS. REJECTION CLAUSE APPLICABLE AS PER GTC BP 200102A.

9. EVALUATION IN CASE OF MORE THAN ONE L-1 BIDDER:

IN THE COURSE OF EVALUATION, IF MORE THAN ONE BIDDER HAPPENS TO OCCUPY L-1 STATUS, EFFECTIVE L-1 WILL BE DECIDED BY SOLICITING DISCOUNTS FROM THE RESPECTIVE L-1 BIDDERS.

IN CASE MORE THAN ONE BIDDER HAPPENS TO OCCUPY THE L-1 STATUS EVEN AFTER SOLICITING DISCOUNTS, THE L-1 BIDDER SHALL BE DECIDED BY A TOSS / DRAW OF LOTS, IN THE PRESENCE OF THE RESPECTIVE L-1 BIDDER(S) OR THEIR REPRESENTATIVE(S).

RANKING WILL BE DONE ACCORDINGLY. DECISION OF BHEL IN SUCH SITUATIONS SHALL BE FINAL AND BINDING.

10. THE BIDDER DECLARES THAT THEY WILL NOT ENTER INTO ANY ILLEGAL OR UNDISCLOSED AGREEMENT OR UNDERSTANDING, WHETHER FORMAL OR INFORMAL WITH OTHER BIDDER(S). THIS APPLIES IN PARTICULAR TO PRICES, SPECIFICATIONS, CERTIFICATIONS, SUBSIDIARY CONTRACTS, SUBMISSION OR NON-SUBMISSION OF BIDS OR ANY OTHER ACTIONS TO RESTRICT COMPETITIVENESS OR TO INTRODUCE CARTELIZATION IN THE BIDDING PROCESS.

IN CASE, THE BIDDER IS FOUND HAVING INDULGED IN ABOVE ACTIVITIES, SUITABLE ACTION SHALL BE TAKEN BY BHEL AS PER EXTANT POLICIES / GUIDELINES.

11. No request for extension of tender due date will be entertained after due date and time of tender opening under any circumstances. Hence all vendors are requested to submit their bid well within due date and time only.

12. The bidder / supplier / contractor will, when presenting his bid, declare whether other family firms or sister concern affiliates / subsidiary firms are participating in the same tender, so as to eliminate the possibility of cartel formation. Format for declaration is available in the NIT documents for this enquiry.

13. For this procurement, Public Procurement (Preference to Make in India) Order (PPP-MII Order), 2017 vide No. P-45021/2/2017-B.E.-II dated 15.06.2017, 28.05.2018, 29.05.2019 & 04.06.2020 and subsequent Orders issued by the respective Nodal Ministry shall be applicable even if issued after issue of this NIT but before finalization of contract / PO / WO against this NIT.

In the event of any Nodal Ministry prescribing higher or lower percentage of purchase preference and / or local content in respect of this procurement, same shall be applicable.

14. Vendors to also inform:

- a. Self-certification of Minimum Local content if more than 50% : Yes / No.
- b. Spell out details of location of value addition.

Bidders or successors can be debarred for false declarations for up to 2 years. Debarred suppliers not eligible for preference in any other procuring entity.

15. Margin of purchase preference to make in India is 20% as per Govt. of India Order No. P-45021/2/2017-BE-II DTD 15.06.17, 28.05.2018, 29.05.2019 & 04.06.2020 and subsequent Orders issued by the respective Nodal Ministry. Suppliers to comply & take a note of the same.

16. For this procurement, the local content to categorize a supplier as a Class I local supplier / Class II local Supplier / Non-Local supplier and purchase preference to Class I local supplier, is as defined in Public Procurement (Preference to Make in India), Order 2017 dated 04.06.2020 issued by DPIIT. In case of subsequent orders issued by the nodal ministry, changing the definition of local content for the items of the NIT, the same shall be applicable even if issued after issue of this NIT, but before opening of Part-II bids against this NIT.

17. FRAUD PREVENTION POLICY: THE BIDDER ALONG WITH ITS ASSOCIATE / COLLABORATORS / SUB-CONTRACTORS / SUBVENDORS / CONSULTANTS / SERVICE PROVIDERS SHALL STRICTLY ADHERE TO BHEL FRAUD PREVENTION POLICY DISPLAYED ON BHEL WEBSITE [HTTP://WWW.BHEL.COM](http://www.bhel.com) AND SHALL IMMEDIATELY BRING TO THE NOTICE OF BHEL MANAGEMENT ABOUT ANY FRAUD OR SUSPECTED FRAUD AS SOON AS IT COMES TO THEIR NOTICE. BHEL CONCILIATION SCHEME SHALL BE APPLICABLE.

18. GST TDS CLAUSE: VIDE NOTIFICATION NO. 50/2018 DATED 13.09.18, SECTION 51 CGST HAS BEEN IMPLEMENTED BY CBIC WHICH PROVIDES FOR GST TDS @ 2% (IGST 2% OR CGST 1% + SGST 1%) & SHALL BE APPLICABLE WHERE CONTRACT VALUE IS MORE THAN RS. 2.5 LAKHS & SUPPLIER IS REGISTERED UNDER GST. TDS RETURN SHALL BE FILED AND TDS CERTIFICATES SHALL BE ISSUED BY BHEL AS PER APPLICABLE PROVISIONS. AS PER SEC 51 OF CGST ACT READ WITH NOTIFICATION 50 OF CENTRAL TAX DATED 13TH SEP 2018, TDS SO DEDUCTED SHALL BE REFLECTED ON THE GST PORTAL OF THE VENDOR / CONTRACTOR. IT SHALL BE AS PER PREVAILING GOVERNMENT NORMS AS APPLICABLE.

19. As you are kindly aware that Government e-Marketplace (GeM) is a one stop portal to facilitate online procurement of Goods & Services required by various Government Departments/ Organizations/ PSUs. GeM aims to enhance transparency, efficiency and speed in public procurement. Detailed Instructions/ Guides/ Videos/ FAQs for registration and processes are available on the portal (<https://gem.gov.in>).

BHEL being a PSU, would like that its suppliers / contractors also have visibility on this portal so that GeM can be used for procurement by BHEL.

Hence, you are requested to get yourselves registered on GeM.

20. "The offers of the bidders who are under suspension as also the offers of the bidders, who engage the services of the firms debarred across BHEL, shall be rejected. The list of firms debarred across BHEL is available on BHEL web site www.bhel.com.

1.0 Integrity commitment, performance of the contract and punitive action thereof:

1.1. Commitment by BHEL:

BHEL commits to take all measures necessary to prevent corruption in connection with the tender process and execution of the contract. BHEL will during the tender process treat all Bidder(s) in a transparent and fair manner, and with equity.

1.2. Commitment by Bidder/ Supplier/ Contractor:

1.2.1. The bidder/ supplier/ contractor commit to take all measures to prevent corruption and will not directly or indirectly influence any decision or benefit which he is not legally entitled to nor will act or omit in any manner which tantamount to an offence punishable under any provision of the Indian Penal Code, 1860 or any other law in force in India.

1.2.2. The bidder/ supplier/ contractor will, when presenting his bid, disclose any and all payments he has made, and is committed to or intends to make to agents, brokers or any other intermediaries in connection with the award of the contract and shall adhere to relevant guidelines issued from time to time by Govt. of India/ BHEL.

1.2.3. The bidder/ supplier/ contractor will perform/ execute the contract as per the contract terms & conditions and will not default without any reasonable cause, which causes loss of business/ money/ reputation, to BHEL.

If any bidder/ supplier/ contractor during pre-tendering/ tendering/ post tendering/ award/ execution/ post-execution stage indulges in malpractices, cheating, bribery, fraud or and other misconduct or formation of cartel so as to influence the bidding process or influence the price or acts or omits in any manner which tantamount to an offence punishable under any provision of the Indian Penal Code, 1860 or any other law in force in India, then, action may be taken against such bidder/ supplier/ contractor as per extant guidelines of the company available on [www. bhel.com](http://www.bhel.com) and/or under applicable legal provisions”.

21. "A bidder shall not have conflict of interest with other bidders. Such conflict of interest can lead to anti-competitive practices to the detriment of Procuring Entity's interests. The bidder, found to have a conflict of interest shall be disqualified. A bidder may be considered to have a conflict of interest with one or more parties in this bidding process, if:

a) they have controlling partner (s) in common;

or

b) they receive or have received any direct or indirect subsidy/ financial stake from any of them;

or

c) they have the same legal representative/agent for purposes of this bid;

or

d) they have relationship with each other, directly or through common third parties, that puts them in a position to have access to information about or influence on the bid of another Bidder,·

or

e) Bidder participates in more than one bid in this bidding process. Participation by a Bidder in more than one Bid will result in the disqualification of all bids in which the parties are involved. However, this does not limit the inclusion of the components/ sub-assembly/ Assemblies from. one bidding manufacturer in more than one bid;

or

f) In cases of agents quoting in offshore procurements, on behalf of their principal manufacturers, one agent cannot represent two manufacturers or quote on their behalf in a particular tender enquiry. One manufacturer can also authorise only one agent/dealer. There can be only one bid from the following:

1. The principal manufacturer directly or through one Indian agent on his behalf; and

2. Indian/foreign agent on behalf of only one principal,·

or

g) A Bidder or any of its affiliates participated as a consultant in the preparation of the design or technical specifications of the contract that is the subject of the Bid,·

or

h) In case of a holding company having more than one independently manufacturing units, or more than one unit having common business ownership/management, only one unit should quote. Similar restrictions would apply to closely related sister companies. Bidders must proactively declare such sister/common business/ management units in same/ similar line of business. "

22. PERFORMANCE SECURITY: PERFORMANCE SECURITY SHALL BE 5% OF THE CONTRACT VALUE.

MODE OF DEPOSIT:

A) PERFORMANCE SECURITY MAY BE FURNISHED IN THE FOLLOWING FORMS:

(I) LOCAL CHEQUES OF SCHEDULED BANKS (SUBJECT TO REALIZATION)/ PAY ORDER/ DEMAND DRAFT/ ELECTRONIC FUND TRANSFER IN FAVOUR OF BHEL.

(II) BANK GUARANTEE FROM SCHEDULED BANKS / PUBLIC FINANCIAL INSTITUTIONS AS DEFINED IN THE COMPANIES ACT. THE BANK GUARANTEE FORMAT SHOULD HAVE THE APPROVAL OF BHEL.

(III) FIXED DEPOSIT RECEIPT ISSUED BY SCHEDULED BANKS / PUBLIC FINANCIAL INSTITUTIONS AS DEFINED IN THE COMPANIES ACT (FDR SHOULD BE IN THE NAME OF THE CONTRACTOR, A/C BHEL).

(IV) SECURITIES AVAILABLE FROM INDIAN POST OFFICES SUCH AS NATIONAL SAVINGS CERTIFICATES, KISAN VIKAS PATRAS ETC. (HELD IN THE NAME OF CONTRACTOR FURNISHING THE SECURITY AND DULY ENDORSED/ HYPOTHECATED/ PLEDGED, AS APPLICABLE, IN FAVOUR OF BHEL).

(V) INSURANCE SURETY BOND.

(NOTE: BHEL WILL NOT BE LIABLE OR RESPONSIBLE IN ANY MANNER FOR THE COLLECTION OF INTEREST OR RENEWAL OF THE DOCUMENTS OR IN ANY OTHER MATTER CONNECTED THEREWITH)

PERFORMANCE SECURITY IS TO BE FURNISHED WITHIN 14(FOURTEEN) DAYS AFTER NOTIFICATION OF THE AWARD AND IT SHOULD REMAIN VALID FOR A PERIOD OF 60 (SIXTY) DAYS BEYOND THE DATE OF COMPLETION OF ALL CONTRACTUAL OBLIGATIONS OF THE SUPPLIER, INCLUDING WARRANTY OBLIGATIONS.

FORFEITURE OF PERFORMANCE SECURITY: THE PERFORMANCE SECURITY WILL BE FORFEITED AND CREDITED TO BHEL'S ACCOUNT IN THE EVENT OF A BREACH OF CONTRACT BY THE SUPPLIER.

PS SHOULD BE REFUNDED TO THE CONTRACTOR WITHOUT INTEREST, AFTER HE DULY PERFORMS AND COMPLETES THE CONTRACT IN ALL RESPECTS BUT NOT LATER THAN 60(SIXTY) DAYS OF COMPLETION OF ALL SUCH OBLIGATIONS INCLUDING THE WARRANTY UNDER THE CONTRACT.

THE PERFORMANCE SECURITY SHALL NOT CARRY ANY INTEREST.

GENERAL & SPECIAL TERMS AND CONDITIONS OF ENQUIRY AND INDIGENOUS P.O., BHEL SPECIFICATION, DRAWINGS, DECLARATION AGAINST CARTEL FORMATION ARE ENCLSOED. PLEASE FILL UP TECHNO-COMMERCIAL ANNEXURE AND DECLARATION AGAINST CARTEL FORMATION DULY SEALD AND SIGNED PROPERLY AND SEND IT ALONG WITH YOUR OFFER.



BHARAT HEAVY ELECTRICALS LIMITED, BHOPAL
TRACTION MACHINES ENGINEERING DIVISION



Vendor information for Technical Qualification Requirement

Ref No. TME/PQR/IM3004/SC-Ring

Dated: 20/03/2023

Technical Pre-Qualification requirement of **Short Circuit Ring** is as under:

SI No.	Description	Vendor to comment	
		Complied / Not complied	Supporting relevant document to be submitted
1.	"Short Circuit Ring" should be exactly a) As per Drawing b) As per specification mentioned in the enquiry / NIT	Yes/No	-
2.	Vendor confirms that all inspection and testing requirements have been studied and will be complied.	Yes/No	-
3.	Vendor to necessarily have in-house Plant & machinery required to manufacture the tendered item.	Yes/No	Details of Machinery & Plant to be submitted.
4.	Testing facilities shall be available preferably in-house with vendor for ensuring quality of raw material, in-process and finished product as per specification requirements. All testing facilities have to be duly calibrated. List of outsourced facilities (if used) may be submitted. Outsourced testing labs/firms should necessarily be NABL accredited.	Yes/No	Details of testing facilities to be submitted.
5.	Manufacturing and testing facilities assessment may be carried out by BHEL at supplier works. Supplier to give confirmation to agree for the same.	Yes/No	-
6.	Manufacturing / supply experience in preceding 2 years (from tender opening date) of same/similar* item to Indian Railway or OEM of Traction Machine manufacturer is required.	Yes/No	Un-priced PO copies of same/similar item in preceding 2 years from original enquiry due date & Supply proof (Delivery challan / invoice etc.) of corresponding PO
7.	Vendor should be a manufacturer and not a trader.	Yes/No	-

Note:

1. Compliance of all the points of T-PQR are mandatory. In absence of compliance of above, vendor's offer is liable to be rejected.
2. Declaration by vendor regarding all the information / compliance submitted should be correct in all respect. In case any deviation / false information is revealed later on, BHEL is free to initiate appropriate punitive proceeding as per prevalent processes and guidelines of company.
3. (*): Copper Alloy **Resistance ring / Short circuit ring** with Outer diameter more than 200 mm shall be considered as similar item.

Prepared By:	Checked By:	Approved By:
 (Kunal Jugvekar) Manager/TME	 20.03.23 (S K Yadav) Sr. Manager/TME	 20/03/23 (V Rawtiya) DGM/TME

PVC Annexure

Basis of PO Unit Rate

Bidder have to quote only firm basic fabrication rate in operated currency (INR) per Number (NO).

$$\text{UNIT MATERIAL COST (in Rs/ NO)} = \text{FABRICATION RATE (in Rs/ NO)} + \{\text{COPPER RATE (in Rs/ Kg)} \times 9.06\}$$

#9.06 Kg is weight of Short Circuit Ring per Number (NO).

Where,

$$\text{Copper rate (Rs. /Kg)} = (\text{LME} + \text{Premium}) \times \text{Multiplication factor} \times \text{SBI TT selling} / 1000.$$

The evaluation shall be done in INR only. Premium- **190 US\$/MT** and Multiplication factor- **1.0550** will be fixed for all suppliers.

Applicable LME & SBI TT selling rate will be determined as per criteria given below.

- A. **For Tender evaluation purpose**, Copper rate shall be calculated as explained below:
Copper rate of LME CSP and SBI TT Selling (US\$-INR) rate as on enquiry due date of Techno-Commercial bid shall be considered. If relevant day happens to be holiday, then rates as on previous working day shall be taken for calculation.
- B. **For purpose of Purchase order placement on successful Bidder**: - The actual LME CSP for copper and SBI TT Selling rate prevailing on next LME working day from the date of issue of LOI by BHEL shall be considered. The LME/ SBI TT Selling rate shall replace the values in the above formula.
- C. **Fabrication Rate**: Fabrication rate (including tooling, Copper packing - forwarding and other charges, if any, etc) as quoted in price bid (on e-procurement portal) shall be firm during the validity of Rate Contract.

BHARAT HEAVY ELECTRICALS LIMITED, BHOPAL
QUALITY ASSURANCE PLAN FOR SHORT CIRCUIT (SC) RING TO BHEL ORDERING SPECIFICATION/DRAWING AS PER PO

QUALITY PLAN NO. - QAP/QTM/VENDOR QAP/2022-23/ SHORT CIRCUIT (SC) RING REV 00 DTD 10/03/2023
 Reference Document- PO DRAWING/SPECIFICATION

SL. NO	COMPONENT	CHARACTERISTICS	TYPE OF CHECK	QUANTAM OF CHECK		REFEREN CE DOCUMENT	ACCEPTANCE NORMS	FORMAT OF RECORD	INSPECTION AGENCY	REMARKS
				TP	TPIA					
1)	Raw material	a) Chemical properties b) Oxygen content	TC verification	100%	100%	As per specification	As per specification	MTC	BHEL/TPIA	SOURCES MENTIONED IN SPECIFICATION. RAW MATERIAL TC to be co-related to finished material and to be verified by TPIA
2)	Dimension	Dimension	Measurement	100%	5 Rings per lot (w)	As per drawing & specification	As per drawing & Specification	Supplier record	BHEL/TPIA	
3)	Visual check	Free from any piping, crow feet, indentations, foreign particles or inclusion, surface defect. Twists & entanglements	Visual	100%	5 Rings per lot (w)	As per drawing & specification	As per drawing & specification	Supplier record	BHEL/TPIA	

Prepared By

(Signature)
 मजिस्ट्रेट/ग.स. रथोरे
 स. प्रबन्धक/Dy. Manager
 क्यू. टी. एम. विभाग/QTM Division
 बी.एच.ई.एल., भोपाल/B.H.E.L., BHOPAL

Approved By

(Signature)
 मजिस्ट्रेट/ग.स. रथोरे
 स. प्रबन्धक/Dy. Manager
 क्यू. टी. एम. विभाग/QTM Division
 बी.एच.ई.एल., भोपाल/B.H.E.L., BHOPAL



BHARAT HEAVY ELECTRICALS LIMITED, BHOPAL

QUALITY ASSURANCE PLAN FOR SHORT CIRCUIT (SC) RING TO BHEL ORDERING SPECIFICATION/DRAWING AS PER PO

QUALITY PLAN NO. – QAP/QTM/VENDOR QAP/2022-23/ SHORT CIRCUIT (SC) RING REV 00 DTD 10/03/2023
Reference Document- PO DRAWING/SPECIFICATION

4)	Testing on finished ring	Chemical properties	Testing	one sample per lot at NABL lab	RR	As per specification	As per specification	Supplier record	BHEL/TPIA	NABL LAB tested TC to be verified and co-related by TPIA and submitted to BHEL as per specification.
		Mechanical properties	Testing	one sample per lot At NABL lab	RR	As per specification	As per specification	Supplier record	BHEL/TPIA	2 nos test sample to be furnished to BHEL duly stamped by TPIA as per specification.
		NDT testing: 1) ultrasonic testing/Eddy current testing	Testing	One sample per lot at NABL LAB & 100 % by supplier	1 sample per lot (W)	As per specification	As per specification	Supplier record	BHEL/TPIA	
		Electrical properties a) Electrical Conductivity	Testing	100 %	5 Rings per lot (W)	As per specification	As per specification	Supplier record	BHEL/TPIA	

Prepared By

Approved By

G.S. Rathore
गणेश गणेश राठोर / G.S. RATHORE
 Dy. Manager
 कर्म. विभाग / QTM Division
 बी.एस.एल. भोपाल / BHEL, BHOPAL

[Signature]
 [Stamp]
 [Text]

BHARAT HEAVY ELECTRICALS LIMITED, BHOPAL
QUALITY ASSURANCE PLAN FOR SHORT CIRCUIT (SC) RING TO BHEL ORDERING SPECIFICATION/DRAWING AS PER PO

QUALITY PLAN NO. – QAP/QTM/VENDOR QAP/2022-23/ SHORT CIRCUIT (SC) RING REV 00 DTD 10/03/2023
Reference Document- PO DRAWING/SPECIFICATION

Page : 3 of 3

5)	Identification vendor name, PO & job serial no., Hardware fitment	Visual	Visual	100%	5 Rings per lot	As per drawing & specification	As per drawing & Specification	Supplier record	BHEL/TPIA	Witness
6)	Packing to avoid transit damage	Visual	Visual	100%	20%	As per drawing & specification	As per drawing & specification	Packing list for each kit box	BHEL/TPIA	Packing to be such that no damages should occur during transit. 1 kit items should be placed in on 1 box

Abbreviations: W-Witness, RR-record review, TPIA-Third party inspection agency, TP=Task performer,

Prepared By

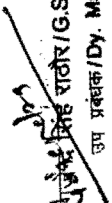

G.S. RATHORE / G.S. RATHORE
 Dy. Manager
 Quality Assurance / QTM Division
 BHEL, Bhopal

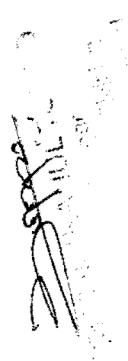
Approved By

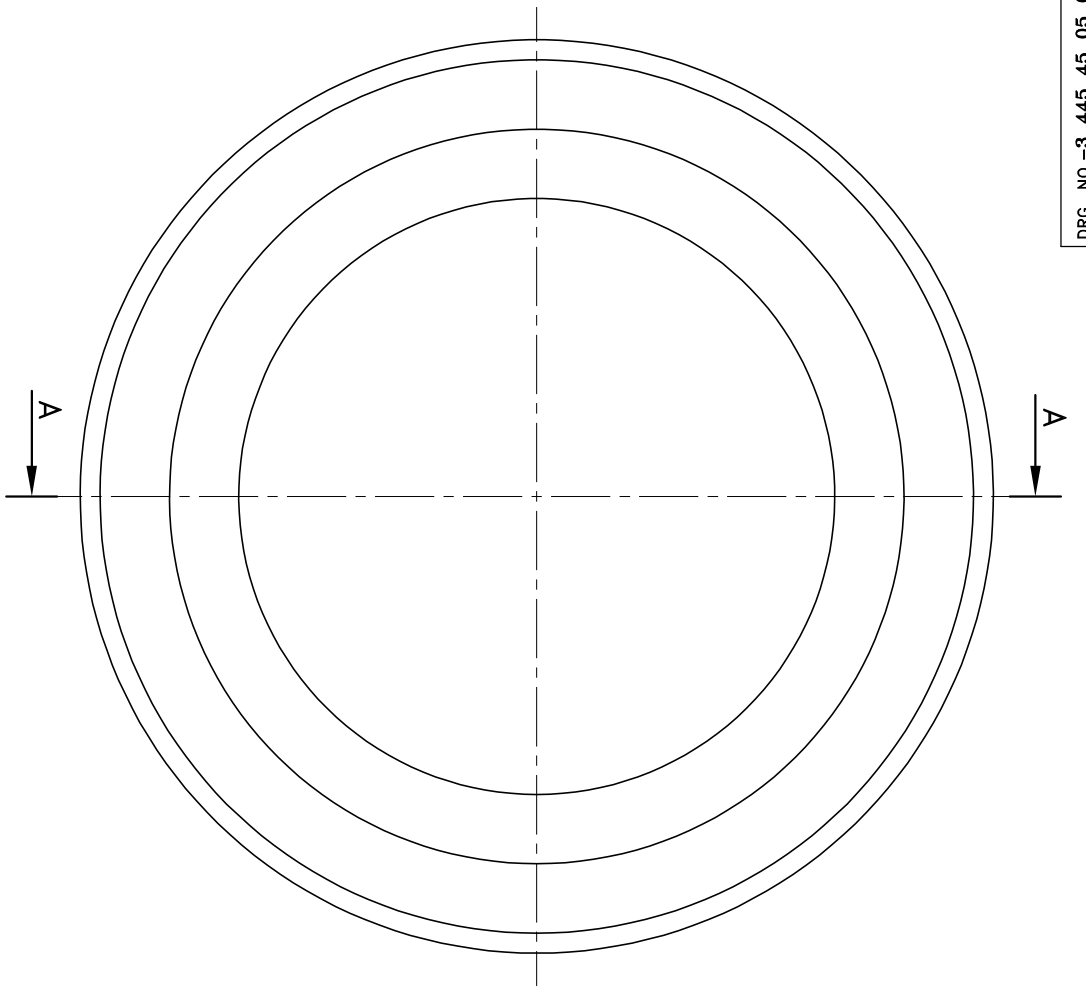

INVENTORY NO. 1832359/2023/HEP-MNX35400
SIGN. & DATE
REF. DRG. NO.

FIRST ANGLE PROJECTION
150 50 54 54 8-ON DRG



NOTE:-
1. MACHINE ALL OVER $\sqrt{3.2}$ REMOVE SHARP EDGES.

REV.	DATE	ALTERED	REV.	DATE	ALTERED	REV.	DATE	ALTERED	REV.	DATE	ALTERED	REV.	DATE	ALTERED	REV.	DATE	ALTERED	REV.	DATE	ALTERED
		CHECKED			CHECKED			CHECKED			CHECKED			CHECKED			CHECKED			CHECKED
		APPROVED			APPROVED			APPROVED			APPROVED			APPROVED			APPROVED			APPROVED
02	21.09.23		02	21.09.23		02	21.09.23		02	21.09.23		02	21.09.23		02	21.09.23		02	21.09.23	
ZONE IN SECTION-AA CH. 8X45																				
ADDED.																				

SECTION-AA

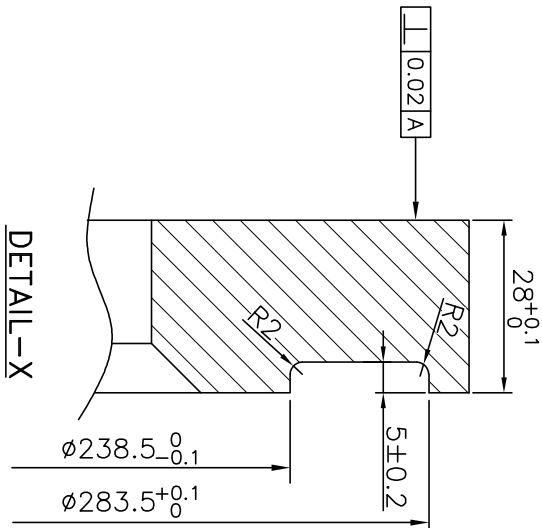
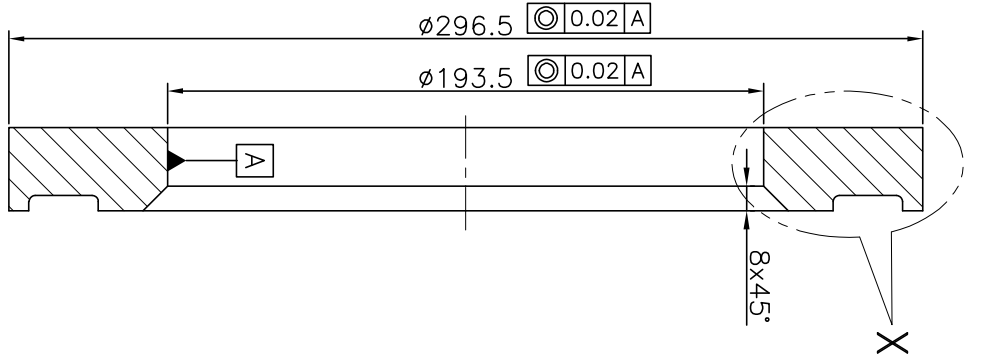

001	64 65	74 76 79 24	27 29	58 59 60	77 78 31 34	55 56 57 58 59 60	61 62 63 64 65	66 67 68 69 70 71	72
QTY	VAR 00	REMARKS	VAR NO.	ITEM NO.	DESCRIPTION	DRAWING NO.	UNIT WGT.	QTY.	NO. OF
001					SHORT CIRCUIT RING	TM23610	9.06		01

ADDITIONAL INFORMATION		TYPE OF PRODUCT		NAME OF CUSTOMER/PROJECT		3-PHASE TRACTION MOTOR	
REFERENCE DRG-444545922005		OR		BHARAT HEAVY ELECTRICALS LTD.		BHOPLI	
STATUS OF DRAWING		DISTRIBUTION OF PRINTS		TAX-1,		TAX-3, CM-1,	
TAX-1,		TAX-1,		TAX-1,		TAX-3, CM-1,	







BHARAT HEAVY ELECTRICALS LTD.
BHOPLI

UNTO. DMS. GR.		SCALE		WEIGHT		DWT. NO.	
TM20079		9.06		2 445 45 05 051		002	
GR M		NTS		REF. TO ASST. DRG.		ITEM NO.	
4051		9.06		2 445 45 05 051		002	
TITLE		DRAWING NO.		SHT. NO.		NO. OF SHT.	
SHORT CIRCUIT RING DE & NDE		3 445 45 05 051		01		01	

SIZE A3

ALL DIMENSIONS ARE IN mm

		PRODUCT STANDARD TME DIVISION, BHOPAL		TM 23610																														
				PAGE 01 OF 02																														
	TME/2011																																	
COPYRIGHT AND CONFIDENTIAL The information on this document is the property of BHARAT HEAVY ELECTRICALS LTD. It must not be used directly or indirectly in any way detrimental to the interest of the company	SPECIFICATION OF FORGED SHORT CIRCUIT (SC) RINGS																																	
	<p>1.0 Scope: The High Strength, High Conductivity Copper alloy material as per this specification shall comply with the requirements in chemical composition, mechanical & electrical properties and all other listed requirements.</p> <p>SC Ring's dimensions & tolerances to be as per the respective drawing as specified in the PO.</p> <p>2.0 Covering Standard: The material shall in general conform to BS EN 12420-2014, Material designation CuCr1Zr with Symbol CW106C.</p> <p>3.0 Processing Final properties of the SC Ring shall be obtained by solution heat treatment & precipitation hardening. Additionally, 2 nos. test pieces shall to be similarly processed for submission to BHEL for validation. Sample size to be 250 mm length of Φ20mm.</p> <p>4.0 Freedom from Defects Rings shall be clean and smooth without voids, cracks and other harmful defects which may affect their utility.</p> <p>5.0 Technical Requirement: 5.1 Chemical Composition: The chemical composition to be as follows:</p> <table border="1" data-bbox="292 1368 1426 1534"> <thead> <tr> <th>Element</th> <th>Cu</th> <th>Cr</th> <th>Fe</th> <th>Si</th> <th>Zr</th> <th>Oxygen</th> <th>Others total Including Oxygen</th> </tr> </thead> <tbody> <tr> <td>Minimum</td> <td rowspan="2">Remainder</td> <td>0.50</td> <td>-</td> <td>-</td> <td>0.03</td> <td>-</td> <td>-</td> </tr> <tr> <td>Maximum</td> <td>1.20</td> <td>0.08</td> <td>0.10</td> <td>0.30</td> <td>10 ppm</td> <td>0.20</td> </tr> </tbody> </table> <p>5.2 Mechanical Properties:</p> <p>To be tested as per IS:1608</p> <table data-bbox="355 1666 1043 1765"> <tr> <td>Tensile Strength N/mm²</td> <td>370 minimum</td> </tr> <tr> <td>0.2% Proof Strength N/mm²</td> <td>270 minimum</td> </tr> <tr> <td>Elongation %</td> <td>15 minimum</td> </tr> </table>						Element	Cu	Cr	Fe	Si	Zr	Oxygen	Others total Including Oxygen	Minimum	Remainder	0.50	-	-	0.03	-	-	Maximum	1.20	0.08	0.10	0.30	10 ppm	0.20	Tensile Strength N/mm ²	370 minimum	0.2% Proof Strength N/mm ²	270 minimum	Elongation %
Element	Cu	Cr	Fe	Si	Zr	Oxygen	Others total Including Oxygen																											
Minimum	Remainder	0.50	-	-	0.03	-	-																											
Maximum		1.20	0.08	0.10	0.30	10 ppm	0.20																											
Tensile Strength N/mm ²	370 minimum																																	
0.2% Proof Strength N/mm ²	270 minimum																																	
Elongation %	15 minimum																																	
Revision: 01																																		
Date: 16-03-2023	Distribution	Qty.	Approved:																															
	TXM	1	 V. Rawtiya 16/02/23																															
	QTM	1	Prepared:	Checked:	Date of first issue:																													
	TME	1	 K. Dugvekar 16/3/23	 S. K. Yadav 16/03/23	10-03-2023																													

	 <p style="text-align: center;">PRODUCT STANDARD TME DIVISION, BHOPAL</p> <p>TME/2011</p>	TM 23610 PAGE 02 OF 02
COPYRIGHT AND CONFIDENTIAL The information on this document is the property of BHARAT HEAVY ELECTRICALS LIMITED It must not be used directly or indirectly in any way detrimental to the interest of the company	<p>5.3 Electrical Properties When tested in accordance with IS:3635, the electrical resistivity should correspond to the following minimum Electrical conductivity of IACS standard.</p> <p style="text-align: center;">Electrical Conductivity at 20°C 75% IACS minimum</p> <p>6.0 Test Sample Refer Cl. 3.0 above for sample size and quantity. Such samples to be submitted to BHEL per heat.</p> <p>7.0 Testing</p> <p style="padding-left: 20px;">7.1 Ultrasonic Testing Each SC Ring to be UT Tested as per TM98246 Table-1, Volume A & Level-1.</p> <p>8.0 Test Certificates Following TCs to be enclosed with each lot of finished component to BHEL:</p> <p style="padding-left: 20px;">8.1 Raw Material mill TC (per heat) 8.2 Sample size as per Cl. 6.0 (per heat) 8.3 Dimensional Report of the SC Ring (each SC Ring/component) 8.4 Electrical Conductivity (per lot) 8.5 Chemical analysis (per lot) 8.6 Mechanical & Chemical property TC from NABL accredited lab (per lot)</p> <p style="padding-left: 40px;">8.6.1 Tensile Strength 8.6.2 0.2% Proof Strength 8.6.3 Elongation 8.6.4 Hardness</p> <p>8.7 Inspection Reports:</p> <p style="padding-left: 20px;">8.7.1 UT Test (Each Ring) 8.7.2 UT Test (1 Ring per lot at NABL accredited lab)</p> <p style="text-align: center;">**_**</p>	



PRODUCT STANDARD
TME DIVN. BHOPAL

TM20079

PAGE 1 OF 1

General tolerance on untolerated dimensions

1.0 Scope

This instruction covers the guidelines for general tolerances to be followed for lengths and angles for machining and forming operations.

This instruction is applicable only for Induction Motors type 6FRA6068 and 6FXA7059 to be manufactured as per ABB design for traction application in AC locos.

2.0 Reference Standards

This limits of tolerances are as indicated in the drawings of ABB and are generally corresponding to ISO 2768 & DIN 7168.

3.0 Tolerances

The limits of tolerances for different range of dimensions are as follows:-

Nominal Dimension	>0.5 ..3.0	>3 ..6	>6 ..30	>30 ..120	>120 ..400	>400 ..1000	>1000 ..2000	>2000 ..4000	>4000 ..8000	>8000 ..12000	>12000 ..16000	>16000 ..20000
Grade 'Rough' or Grade 'R'	+0.15	+0.2	+0.5	+0.8	+1.2	+2	+3	+4	+5	+6	+7	+8
Grade 'Medium' or Grade 'M'	+0.1	+0.1	+0.2	+0.3	+0.5	+0.8	+1.2	+2	+3	+4	+5	+6

4.0 Reference to ABB standards

The limit of tolerances are as appearing on drawings of ABB. No separate spec. of ABB is available for this purpose.

Note: All dimensions are in mm.

COPYRIGHT AND CONFIDENTIAL
 This information in this document is the property of BHARAT HEAVY ELECTRICALS LTD.
 It must not be used directly or indirectly in any way detrimental to the interest of the company

Revision : 00	Distribution	Qty.	Approved: <i>[Signature]</i>		
Date : 02/04/97	TXM CIM PRM TGM TIX TNX	2 / / / / /	m. Brakes Prepared	<i>[Signature]</i> Checked	2/4/97 Date

TCX(TGM)-1 o/c-1