



A Maharatna Company  
ISO 9001 Company  
ISO 50001 Company

பாரத் ஹெவி இலெக்ட்ரிகல்ஸ் லிமிடெட்  
भारत हेवी इलेक्ट्रिकल्स लिमिटेड  
Bharat Heavy Electricals Limited

(A Government of India Enterprise)  
Tiruchirappalli – 620 014

**MATERIALS MANAGEMENT**

Phone: 0431 – 257 4166, 4363; E-mail: sbrajesh@bhel.in, mjjiy@bhel.in; www.bhel.com

**NOTICE INVITING e-TENDER**

Dear Sir/ Ma'am,

Ref : **Tender No. 1802300011 dated 20.02.2023.**

Subject : Two-part **e-Tender** inviting techno-commercial and price bids for supply of **Silver Gaskets for 700MWe SG.**

Kindly submit your competitive offer as per the tender terms and conditions given in the tender document through e-procurement portal <https://eprocurebhel.co.in/> only.

1.	Bid submission start date	09.03.2023, 09:00 Hrs. IST
2.	Bid submission end date	22.03.2023, 12:00 Hrs. IST
3.	Bid opening date (Part-I)	16:00 Hrs IST on dt. 22.03.2023.
4.	Date of price bid opening	The date/ time of price bid opening will be intimated to the techno-commercial qualified tenderer separately.

Note: Change of dates if any will be published as corrigendum. Bidder to check e-procurement portal regularly for updates.

**The tender will be evaluated on Total Package basis.**

**List of Items:**

BOQ Sl. No.	Item Description	Material Code	Qty	Unit
<b>Main supply and Commissioning Spares</b>				
1	SILVER GASKET VAR-01 Specification PC-M-00069 Rev.00 and Drawings 3-93-172-05573/00 & 3-93-172-05575/00.	AD16719317204000	30	NOS
2	SILVER GASKET VAR-02 Specification PC-M-00069 Rev.00 and Drawings 3-93-172-05573/00 & 3-93-172-05575/00.	AD16719317204001	15	NOS
3	SILVER GASKET VAR-03 Specification PC-M-00069 Rev.00 and Drawings 3-93-172-05573/00 & 3-93-172-05575/00.	AD16719317204002	60	NOS

Following list of documents are part of this tender and shall be deemed to form an integral part of contract:

1. Annexure A - Techno - commercial terms and conditions.
2. Prequalification requirements, Technical Specifications and quality requirements as mentioned in clause 1(a), 1(b) and 1(c) of Annexure-A.
3. No Deviation Format.
4. Local content certification formats.
5. Integrity Pact.
6. PBG format along with consortium bank list.
7. Annexure-X Brief procedure for conduct of conciliation proceedings.
8. Annexure DT1 & DT2
9. BOQ format for submission of price bid.

**General Instructions**

1. Pre-bid queries if any shall be send to email ID [sbrajesh@bhel.in](mailto:sbrajesh@bhel.in) and [mjiby@bhel.in](mailto:mjiby@bhel.in) on or before the due date mentioned above.
2. Please quote enquiry no., date and due date in all correspondences.
3. This is only a request for quotation and not an order.
4. Bidder to submit the offer through e-procurement portal only. Offer submitted through any other mode will not be considered.

Thanking you,

For **Bharat Heavy Electricals Limited**

**SB Rajesh Kummar**

Dy. Manager / Materials Management

Fourth floor, 24 Building

B.H.E.L., Tiruchirappalli – 620 014, Tamil Nadu

Phone: 0431-2574166

Email: [sbrajesh@bhel.in](mailto:sbrajesh@bhel.in)

**ANNEXURE-B**  
**TECHNICAL PRE QUALIFICATION REQUIREMENT**

1. Supplier with supply reference of the indented items for nuclear application will only be considered for Bid Evaluation.
2. Supplier should have the capability and experience to manufacture the indented items as per the referred standards mentioned in technical specification (PC-M-00069 Rev.00) for offer acceptance. Acceptance of Supplier Bid/ offer will be subject to submission of the following documents along with Technical offer/bid:
  - a) Documentary Proof [Supply Invoice Copy (ies)/ shipping clearance copy (ies) of supply for nuclear application] clearly indicating supply of the intended item(s) as proof of supplier's experience in manufacture and supply.
  - b) Copy (ies) of Approved Material/Performance Test Certificates of supply for nuclear application with details of Customer and Third Party Inspection Agency if any.
  - c) The evidence for the performance of the required tests as per specification shall also be submitted for verification.





**NUCLEAR POWER CORPORATION OF INDIA LTD.  
(A GOVT. OF INDIA ENTERPRISE)**

SPECIFICATION NO. : PC-M-00069

**TECHNICAL SPECIFICATION  
ON  
SILVER FOIL GASKETS FOR PRIMARY/SECONDARY MANHOLES AND  
HANDHOLES OF MUSHROOM TYPE STEAM GENERATORS  
FOR 700MWe PHWRs**

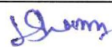
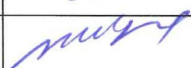
REF. USI NO. : 33111

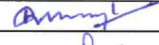
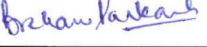
REVISION NO.	:	0			
DATE OF ISSUE (MONTH/YEAR)	:	August, 2018			
TOTAL NO. OF PAGES (Including Cover Sheet)	:	10			

	NAME	Designation	SIGNATURE	DATE
PREPARED BY	Lalit Sharma	EE(ED&PA)		23/08/18
	M.L. Rajput	SEE(SG)		23/08/2018
CHECKED BY	Rahul Mittal	SEE(ED&PA)		23/08/2018
	R.K.Gupta	ACE(SG)		27/8/2018
REVIEWED BY	Braham Parkash	ACE(ED&PA)		27.08.2018
	M.R.S Saxena	AD(SG&HTE)		27/08/18
APPROVED BY	D.Ganesh	AD(ED&SA-I)		27/8/2018

(For Revisions see Revision Control Sheet )

File Name : PC-M-00069

**REVISION CONTROL SHEET**

**DOCUMENT TYPE: TECHNICAL SPECIFICATION**

**NO. : PC-M-00069**

**TITLE: TECHNICAL SPECIFICATION ON SILVER FOIL GASKETS FOR  
PRIMARY/SECONDARY MANHOLES AND HANDHOLES OF MUSHROOM TYPE  
STEAM GENERATORS FOR 700MWe PHWRs**

REV. NO. & DATE	DESCRIPTION OF REVISION	REVISED BY NAME & SIGNATURE	CHECKED BY NAME & SIGNATURE	REVIEWED BY NAME & SIGNATURE	APPROVED BY NAME & SIGNATURE

**NPCIL PROPRIETARY**

**This document contains confidential and protected information and that the same are the intellectual property of Nuclear Power Corporation of India Limited (NPCIL). No part of this document including notably any editorial elements, verbal and figurative marks and images included herein, shall be reproduced or transmitted or utilized or published or stored in any form or by any means now known or hereinafter invented, electronic, digital or mechanical, including photocopying, scanning, recording or by any information storage or retrieval system, without prior written permission from NPCIL, by any person or entity. Unauthorized use, disclosure or copying is strictly prohibited and may constitute unlawful act and can attract legal action.**

*This page has been kept intentionally blank*

<b>NUCLEAR POWER CORPORATION OF INDIA LTD</b>	
<b>TECHNICAL SPECIFICATION ON SILVER FOIL GASKETS FOR PRIMARY/SECONDARY MANHOLES AND HANDHOLES OF MUSHROOM TYPE STEAM GENERATORS FOR 700MWe PHWRs</b>	<b>Page No. : 1 of 6</b>
	<b>Rev. No. : 0</b>

## **1.0 SCOPE**

This specification is for manufacture, examination, testing, inspection, guarantee, tropical packaging and delivery of fine grain silver foil gaskets for Primary/Secondary manholes and hand holes of Mushroom type Steam Generators for 700 MWe PHWR Units. All the requirements under this specification represent minimum requirements.

## **2.0 CONTENTS**

The requirements of this Specification are presented under the following headings.

### **Section**

Scope	1.0
Contents	2.0
Melting	3.0
Chemical Composition	4.0
Heat Treatment	5.0
Other tests	6.0
Silver Foil Gasket Sizes / Dimensions	7.0
Information with Offer	8.0
Marking and Identification	9.0
Reports	10.0
Quality Surveillance	11.0
Preservation, Packing and Shipment	12.0
Sketch -1: Silver foil gaskets for 700 MWe SG	

<b>NUCLEAR POWER CORPORATION OF INDIA LTD</b>	
<b>TECHNICAL SPECIFICATION ON SILVER FOIL GASKETS FOR PRIMARY/SECONDARY MANHOLES AND HANDHOLES OF MUSHROOM TYPE STEAM GENERATORS FOR 700MWe PHWRs</b>	<b>Page No. : 2 of 6</b>
	<b>Rev. No. : 0</b>

### **3.0 MELTING**

Silver foil gaskets shall be of fine grain silver. Remelting shall be done furnaces which are fired by gas or oil.

### **4.0 CHEMICAL COMPOSITION**

For every melt chemical analysis shall be carried out and reported. Fine grain silver shall be of Chemical Composition according to Degussa brochure "Silver and Silver Alloys" as bellow:

Silver---99.85% Nominal  
Ni---0.15±0.04% } Together 100%

### **5.0 HEAT TREATMENT**

The silver foil gaskets shall be finally annealed at 530°C approximately for about 30 minutes holding time. The actual cycle shall be reported.

### **6.0 OTHER TESTS**

#### **6.1 Mechanical Requirements :**

Fine grain silver used for making gaskets shall have high temperature strength and good creep resistance properties so that the gaskets neither undergo creep nor gross plastic yielding under service/test conditions (at 300°C and room temperature respectively).

#### **6.2 Hardness test**

Hardness test shall be carried out at 3 positions uniformly spaced using Vicker's method after final annealing and reported. The hardness shall be in the range of 45 to 65 HV1.

#### **6.3 Material mix-up test**

Every material shall be tested to find out if there is any material mix-up.

<b>NUCLEAR POWER CORPORATION OF INDIA LTD</b>	
<b>TECHNICAL SPECIFICATION ON SILVER FOIL GASKETS FOR PRIMARY/SECONDARY MANHOLES AND HANDHOLES OF MUSHROOM TYPE STEAM GENERATORS FOR 700MWe PHWRs</b>	<b>Page No. : 3 of 6</b>
	<b>Rev. No. : 0</b>

## **7.0 SILVER FOIL GASKET SIZES/DIMENSIONS**

For primary manholes/ Secondary manholes and Handholes refer sketch-1 for

### **7.1 Surface and Dimensional Check / Measurements**

Surface and dimensional checks / measurements shall be done after final annealing and reported. They shall meet requirements as given below:

- 7.2 Surface roughness – Peak to valley height  $R_1 \leq 4$  micron.
- 7.3 Dimensional deviations may be according to “mean DIN 7168”.
- 7.4 Maximum thickness difference  $\Delta s \leq 0.08$ mm.
- 7.5 The profile and dimensional shall be according to the attached sketch-1
- 7.6 All surfaces shall be thoroughly cleaned with acetone, metallicly smooth, free from grease, oil and chlorides. The surfaces shall not have any scratches, grooves and press marks etc. The results of this visual examination shall also be reported.

## **8.0 INFORMATION WITH OFFER**

Following shall be submitted as minimum along with the offer:

- a) Proposed chemical composition of fine grain silver, Vickers hardness (HV1) for silver gasket and details of heat treatment condition/procedure.
- b) Proposed dimensional inspection plan.
- c) Proposed surface finish, flatness and dimensional tolerances.
- d) Proposed check for cleanliness and freedom from surface contaminants such as chlorides etc.
- e) Proposed preservations and packing arrangement.
- f) Manufacturer’s recommendation regarding the re-usability of silver gaskets.

<b>NUCLEAR POWER CORPORATION OF INDIA LTD</b>	
<b>TECHNICAL SPECIFICATION ON SILVER FOIL GASKETS FOR PRIMARY/SECONDARY MANHOLES AND HANDHOLES OF MUSHROOM TYPE STEAM GENERATORS FOR 700MWe PHWRs</b>	<b>Page No. : 4 of 6</b>
	<b>Rev. No. : 0</b>

## **9.0 MARKING AND IDENTIFICATION**

### **9.1 Identification**

The following shall be clearly marked on the folded portion of each gasket using vibroetching process:

- a) Melt number
- b) Specification and grade
- c) Inspecting Authority / Purchaser's seal.

### **9.2 Marking**

Following shall be clearly marked on the packages:

- a) Purchase order number
- b) Box no. and size
- c) Items contained
- d) Destination

## **10.0 REPORTS**

Final documentation consisting of all examination/testing/Inspection reports/certificates shall be compiled in bound volume and they shall be supplied in 4 sets. All these documents shall be in "English" language only.

## **11.0 QUALITY SURVEILLANCE**

Manufacture, examination, testing, inspection, preservation, packing etc. shall be carried out as per written procedures submitted by the manufacturer and approved by the Purchaser. The material ordered shall be subjected to purchaser's quality surveillance. The purchaser's authorized inspection agency shall witness and certify that the material being supplied is in full conformance to this specification. The final documentation consisting of all examination/test/inspection reports/certificates shall be countersigned by the Purchaser's authorized inspection agency.

<b>NUCLEAR POWER CORPORATION OF INDIA LTD</b>	
<b>TECHNICAL SPECIFICATION ON SILVER FOIL GASKETS FOR PRIMARY/SECONDARY MANHOLES AND HANDHOLES OF MUSHROOM TYPE STEAM GENERATORS FOR 700MWe PHWRs</b>	<b>Page No. : 5 of 6</b>
	<b>Rev. No. : 0</b>

## **12.0 PRESERVATION, PACKING AND SHIPMENT**

The supplier shall ensure proper preservation and tropical packing for safe transportation and long storage without any damage/deterioration to the gaskets. Halogen and sulphur free preservatives and packing materials only shall be used. The packing details shall be submitted along with sketches for purchaser's approval. Material shall be shipped only after issue of written "Shipping Release" by Purchaser or his authorized inspection agency.

**NUCLEAR POWER CORPORATION OF INDIA LTD**

**TECHNICAL SPECIFICATION ON  
SILVER FOIL GASKETS FOR PRIMARY/SECONDARY MANHOLES AND  
HANDHOLES OF MUSHROOM TYPE STEAM GENERATORS  
FOR 700MWe PHWRs**

Page No. : 6 of 6

Rev. No. : 0

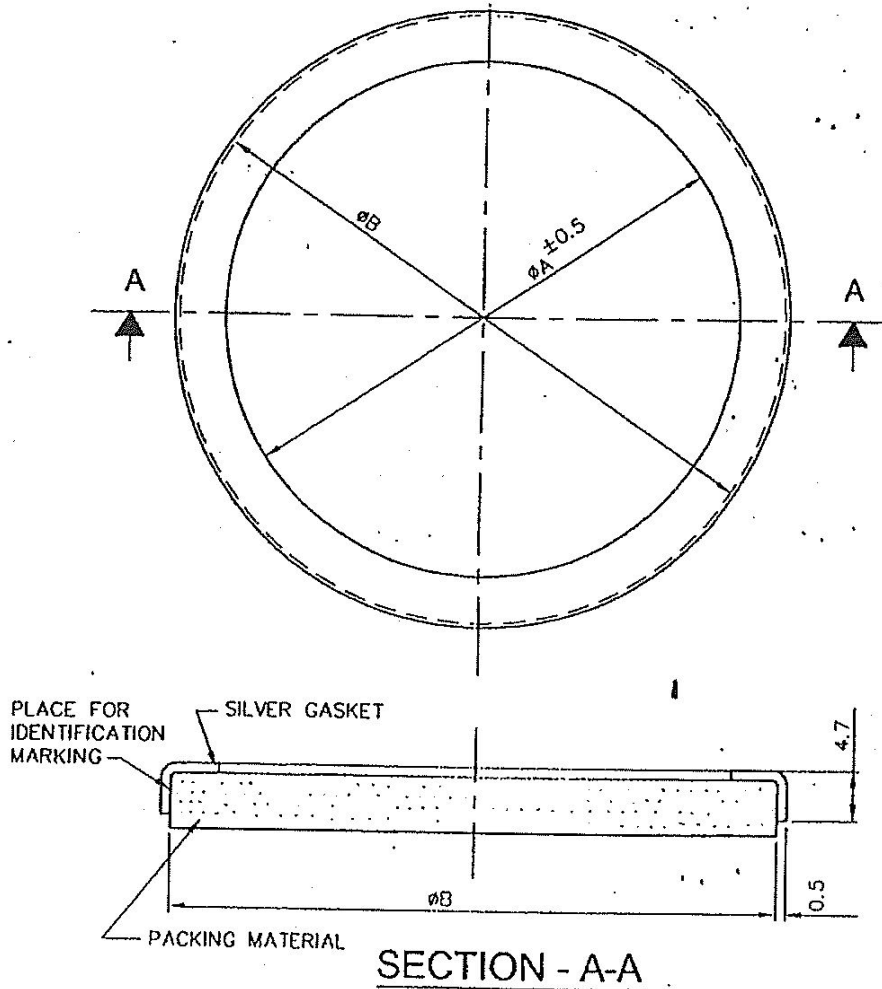

ALL DIMENSIONS ARE IN mm

Sr. No:	$\phi A$	$\phi B$	GASKET FOR
1	525	572 <sup>+1.0</sup> / <sub>+0.5</sub>	PRIMARY MANHOLE
2	206.5	241.5 <sup>+0.8</sup> / <sub>+0.3</sub>	SECONDARY HAND HOLE
3	555	600 <sup>+1.0</sup> / <sub>+0.5</sub>	SECONDARY MANHOLE

**Sketch-1**

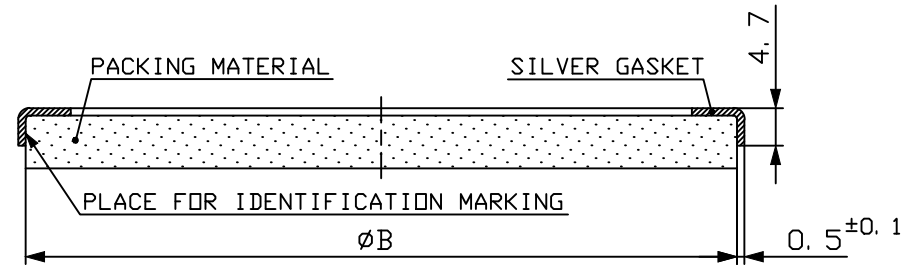

SECTION-AA

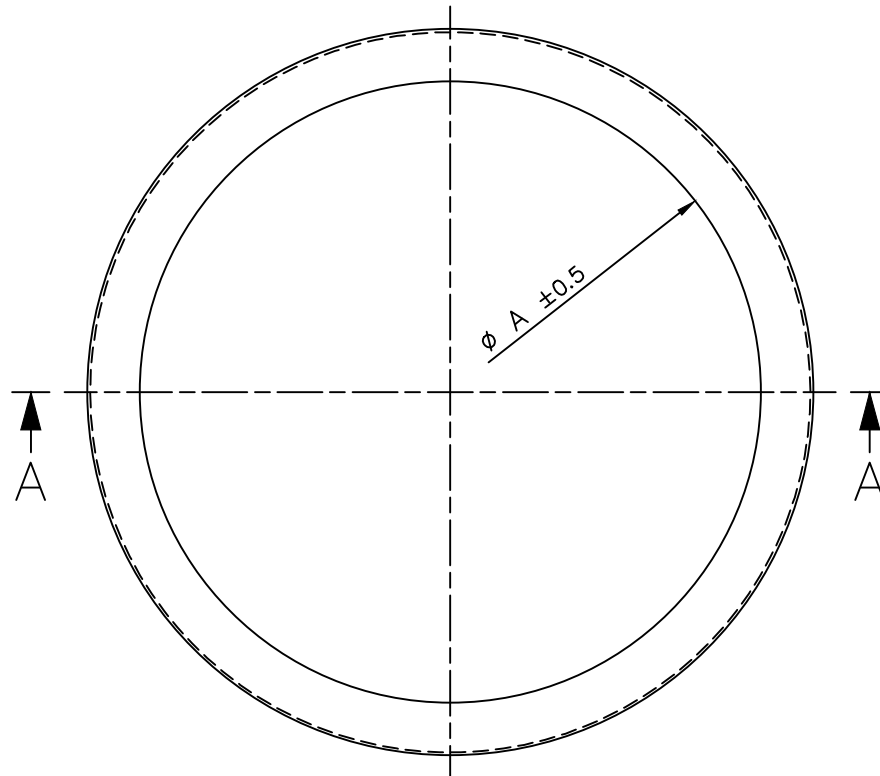

VAR NO.	$\phi A$	$\phi B$	WEIGHT
01	525	$572^{+1.0}_{+0.5}$	1.12
02	555	$600^{+1.0}_{+0.5}$	1.13
03	206.5	$241.5^{+0.8}_{+0.3}$	0.40

NOTES: -

1. MATERIAL SPECIFICATION : FINE GRAIN SILVER
2. APPLICABLE SPECIFICATION : PC-M-00069
3. FOR PACKING DETAILS REFER DRG. NO.: 3-93-172-05575

TOLERANCE IF NOT SPECIFIED SHALL BE AS BELOW (REFER IS 2102-m)

LINEAR				ANGULAR	
0.5 TO 3	$\pm 0.1$	400 TO 1000	$\pm 0.8$	0 TO 10	$\pm 1^\circ$
3 TO 6	$\pm 0.1$	1000 TO 2000	$\pm 1.2$	10 TO 50	$\pm 30'$
6 TO 30	$\pm 0.2$	2000 TO 4000	$\pm 2.0$	50 TO 120	$\pm 20'$
30 TO 120	$\pm 0.3$	-	-	120 TO 400	$\pm 10'$
120 TO 400	$\pm 0.5$	-	-	OVER 400	$\pm 5'$

REV	DATE	ALTERED :
		CHD&APPD :

CAUTION: The information on this document is the property of BHARAT HEAVY ELECTRICALS LTD. It must not be used directly or indirectly in any way detrimental to the interest of the company.

TYPE OF PRODUCT OR NAME OF CUSTOMER/PROJECT		700MWe STEAM GENERATOR W.O.No.D167-001-1-93-172-FLEET (Customer Drg.: 700FLEET/33111/4035/DD/REV.01)					
 05-229/D	Bharat Heavy Electricals Ltd		DRN	NAME NKK	SIGNATURE <i>NKK</i>	DATE	NO. OF VAR
	UNIT: HIGH PRESSURE BOILER PLANT		CHD	MAK/EARUN	<i>MAK</i>	060821	
	TIRUCHIRAPALLI - 620014		APPD	M.A	<i>M.A</i>	070821	
DEPT NC	GRADE OF UNTOL DIM C/M/F	SCALE NTS	WEIGHT (Kg)	REF TO ASSY / OLD DWG		ITEM NO	No OF ITEMS
CODE 150							
TITLE SILVER GASKET			CARD CODE U 01	DRAWING NO : 3-93-172-05573		REV	00

NOTES: -

1. APPLICABLE SPECIFICATION : PC-M-00069

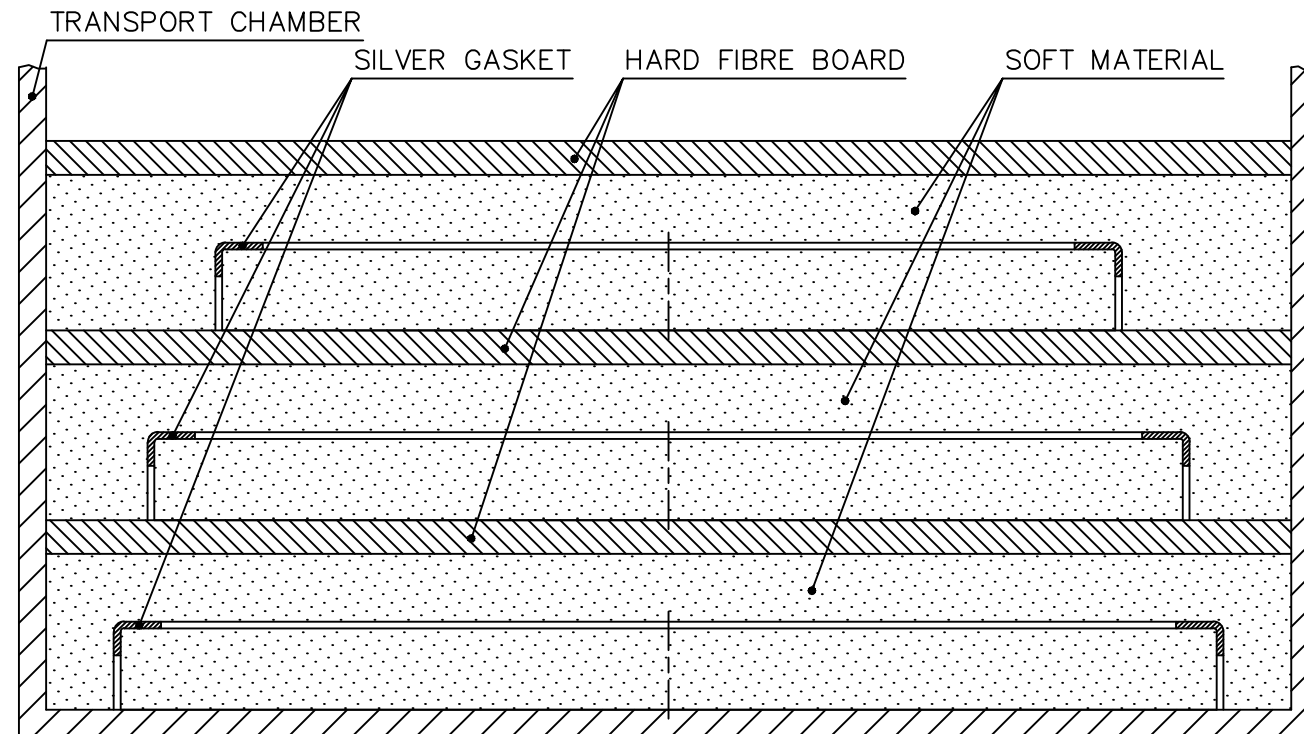

DEPT NC CODE 150		GRADE OF UNTOL DIM C/M/F		SCALE 		WEIGHT (Kg)		TYPE OF PRODUCT OR NAME OF CUSTOMER/PROJECT		700MWe STEAM GENERATOR W.O.No.D167-001-1-93-172-FLEET											
								DEPT NC CODE 150		GRADE OF UNTOL DIM C/M/F		SCALE 		WEIGHT (Kg)		REF TO ASSY / OLD DWG		ITEM NO		No OF ITEMS	
								TITLE PACKING DETAILS FOR SILVER GASKET		CARD CODE U 01		DRAWING NO : 3-93-172-05575		REV 00							

CAUTION: The information on this document is the property of BHARAT HEAVY ELECTRICALS LTD. It must not be used directly or indirectly in any way detrimental to the interest of the company.

REV	DATE	ALTERED :
		CHD&APPD :

**ANNEXURE-C**

Supplier's Logo	Supplier's Name & Address		GENERIC QUALITY PLAN FOR SILVER FOIL GASKETS FOR PRIMARY/ SECONDARY MANHOLES AND HANDHOLES OF MUSHROOM TYPE STEAM GENERATORS					Project: FLEET 700MWe SG				
			Item: Silver Gaskets Sub-system: Steam Generator	QP No.: To be filled by Supplier Rev. No.: To be filled by Supplier Date: To be filled by Supplier Page No.: 1 of 4			W.O.: D167 TO D178-001-93-172					
								P.O No: To be filled		Dated:		
SL NO	COMPONENTS & OPERATIONS	CHARACTERISTICS	TYPE OF CHECK	QUANTUM OF CHECK	REFERENCE DOCUMENT	ACCEPTANCE NORMS	FORMAT OF RECORD		AGENCY			REMARKS
							M	B	N	9.**		
1.	2.	3.	4.	5.	6.	7.	8.	D*				10.
1.0	Raw Material-Incoming Inspection:											
1.1	Fine Grain Silver sheets - re-melting in gas/oil fired furnace.	Chemistry	Review of Documents	100%	PC-M-00069/00	-Ag: fine grain -Ag: 99,85% nominal -Ni: 0.15+/- 0.04% (Ag + Ni together 100%)	TC	√	P	R	---	Melt number to be identified. Re-melting route to be mentioned in TC
1.2	Visual Inspection of Silver sheets	Scratches	Visual	100%	Free from scratches, dents etc.		---	---	P	---	---	---
1.3	Dimension of Silver sheets	Width, Length, Thickness & Thickness variation per sheet	Caliper, Roll meter	100%	Width: 600-630 mm Length-600-630 mm Thickness: 0.5±0.1 mm Thickness variation per sheet: <0.08mm		---	---	P	---	---	---
2.0	IN PROCESS CONTROLS:											
2.1	Heat treatment	Soaking temperature & Time	Record verification / HT Chart verification	100%	PC-M-00069/00 As per HT chart		TC	√	P	R	R	In inert circumstances & Actual HT chart shall be provided with TC.

*[Signature]*  
27/10/2022  
**M. ARUN KUMAR**  
Deputy Manager  
Engg & RPD / ATP  
BHEL, TRICHY - 620 014

Prepared	Reviewed & Approved	Reviewed & Approved	Reviewed & Approved	<b>LEGEND:</b> * RECORDS, IDENTIFIED WITH "TICK" (√) SHALL BE ESSENTIALLY INCLUDED BY SUPPLIER IN QA DOCUMENTATION <b>** M: SUPPLIER B: BHEL, N: NPCIL</b>  <b>P: PERFORM, R: REVIEW W: WITNESS AND H: HOLD</b> <b>TC: TEST CERTIFICATE RD: RECORD</b>
<b>Supplier's Name</b>		BHEL	NPCIL	

Supplier's Logo	Supplier's Name & Address		GENERIC QUALITY PLAN FOR SILVER FOIL GASKETS FOR PRIMARY/ SECONDARY MANHOLES AND HANDHOLES OF MUSHROOM TYPE STEAM GENERATORS					Project: FLEET 700MWe SG		
			Item: Silver Gaskets Sub-system: Steam Generator	QP No.: To be filled by Supplier Rev. No.: To be filled by Supplier Date: To be filled by Supplier Page No.: 2 of 4			W.O.: D167 TO D178-001-93-172			
								P.O No: To be filled		Dated:

SL NO	COMPONENTS & OPERATIONS	CHARACTERISTICS	TYPE OF CHECK	QUANTUM OF CHECK	REFERENCE DOCUMENT	ACCEPTANCE NORMS	FORMAT OF RECORD		AGENCY			REMARKS
							M	D*	M	B	N	
1.	2.	3.	4.	5.	6.	7.	8.	D*	9.**			10.
2.2.1	Tensile strength/ Yield of Silver	Yield Strength (Rp02). Tensile stress (N/mm <sup>2</sup> ) at Room Temperature and at 300°C	Destructive Test	1/melt/ HT Batch	Values shall be mentioned in Supplier's QAP		TC	√	P	R	R	---
2.2.2	Creep at application	Creep test for Silver layer at Room Temperature and at 300°C	% Creep at continuous load	1/melt/ HT Batch	Good Creep resistance, nor gross plastic yielding		TC	√	P	R	R	---
2.3	Hardness	Hardness	Vickers Hardness	3 points/ Sheet	PC-M-00069/00 45 to 65 HV1		TC	√	P	R	R	---
2.4	Grain Size determination	Grain Size	Grain Size	1/melt/ HT Batch	PC-M-00069/00 Fine grain to be ensured.		TC	√	P	R	R	---
2.5	<ul style="list-style-type: none"> <li>Cutting to form Rings</li> <li>Flanging of Rings to form Gaskets</li> </ul>	Cutting Flanging	---	100%	PC-M-00069/00		---	---	P	---	---	----
2.6	Final Dimension check	Dimensions as per drawing	Dimension check	100%	PC-M-00069/00	TC	√	P	R	R	---	
		Difference in thickness (Δs)	Dimension check	100%	PC-M-00069/00							(Δs) ≤ 0.08mm

				<b>LEGEND:</b> * RECORDS, IDENTIFIED WITH "TICK" (√) SHALL BE ESSENTIALLY INCLUDED BY SUPPLIER IN QA DOCUMENTATION ** M: SUPPLIER B: BHEL, N: NPCIL			
Prepared	Reviewed & Approved	Reviewed & Approved	Reviewed & Approved				
Supplier's Name		BHEL	NPCIL	P: PERFORM, R: REVIEW W: WITNESS AND H: HOLD TC: TEST CERTIFICATE RD: RECORD			

Supplier's Logo	Supplier's Name & Address		<b>GENERIC QUALITY PLAN FOR SILVER FOIL GASKETS FOR PRIMARY/ SECONDARY MANHOLES AND HANDHOLES OF MUSHROOM TYPE STEAM GENERATORS</b>					Project: FLEET 700MWe SG W.O.: D167 TO D178-001-93-172 P.O No: To be filled Dated:		
			Item: Silver Gaskets Sub-system: Steam Generator	QP No.: To be filled by Supplier Rev. No.: To be filled by Supplier Date: To be filled by Supplier Page No.: 3 of 4						

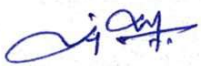
SL NO	COMPONENTS & OPERATIONS	CHARACTERISTICS	TYPE OF CHECK	QUANTUM OF CHECK	REFERENCE DOCUMENT	ACCEPTANCE NORMS	FORMAT OF RECORD		AGENCY			REMARKS
							M	D*	M	B	N	
1.	2.	3.	4.	5.	6.	7.	8.	D*	9.**			10.
2.7	Surface Finish	Surface roughness	Comparator	1/Gasket	PC-M-00069/00 Rt<= 4µm		TC	√	P	R	R	Report shall be submitted for review
2.8	Engraving on gaskets	Melt No, Serial No Specification & Grade	Visual	100%	PC-M-00069/00		---	---	P	---	---	---
2.9	Cleaning with Acetone	Cleanliness	---	100%	PC-M-00069/00		---	---	P	---	---	---
2.10	Check for Cleanliness	Cleanliness	Visual / Cleanliness check	100%	Free from oil, grease & chlorides		---	√	P	R	R	---
2.11	Visual Examination	Visual & Flatness	Visual	100%	No scratches, grooves or press marks on gasket surface and perfectly flat		TC	√	P	R	R	
2.12	Mix up Test	Positive Material Identification	PMI Test	100%	PC-M-00069/00		---	√	P	R	R	--
3.0	<b>Packing Marking and Preservation, Certification.</b>											
3.1	Documents (Test Certificates) shall be sent to BHEL/Trichy prior to dispatch. Dispatch clearance will be given after Acceptance of Test Certificates by BHEL.											
3.2	<u>Packaging:</u>  <b>Marking: P.O. no., Box no. &amp; size, Item contained &amp; Destination to be clearly mentioned on the package</b>											

				<b>LEGEND:</b> * RECORDS, IDENTIFIED WITH "TICK" (√) SHALL BE ESSENTIALLY INCLUDED BY SUPPLIER IN QA DOCUMENTATION <b>** M:</b> SUPPLIER B: BHEL, N: NPCIL <b>P:</b> PERFORM, <b>R:</b> REVIEW <b>W:</b> WITNESS AND <b>H:</b> HOLD <b>TC:</b> TEST CERTIFICATE <b>RD:</b> RECORD
Prepared	Reviewed & Approved	Reviewed & Approved	Reviewed & Approved	
Supplier's Name		BHEL	NPCIL	

Supplier's Logo	Supplier's Name & Address		GENERIC QUALITY PLAN FOR SILVER FOIL GASKETS FOR PRIMARY/ SECONDARY MANHOLES AND HANDHOLES OF MUSHROOM TYPE STEAM GENERATORS					Project: FLEET 700MWe SG				
			Item: Silver Gaskets Sub-system: Steam Generator		QP No.: To be filled by Supplier Rev. No.: To be filled by Supplier Date: To be filled by Supplier Page No.: 4 of 4			W.O.: D167 TO D178-001-93-172				
								P.O No: To be filled		Dated:		
SL NO	COMPONENTS & OPERATIONS	CHARACTERISTICS	TYPE OF CHECK	QUANTUM OF CHECK	REFERENCE DOCUMENT	ACCEPTANCE NORMS	FORMAT OF RECORD		AGENCY			REMARKS
							M	B	N	9.**		
1.	2.	3.	4.	5.	6.	7.	8.	D*				10.

**Note:**

- 1) Final documentation consisting of all examination/ testing/ Inspection reports/ certificates are to be bound in volume and to be supplied in 4 sets. All the documents are to be in English language only.
- 2) Halogen and Sulphur free preservatives and packing material to be used.
- 3) MSTP (Material Sampling Plan), MPP (Manufacturing Process plan) and Heat Treatment Plan etc. shall be submitted by supplier and the same will be subjected to both BHEL & NPCIL approval.
- 4) For all raw materials co-related mill/material test certificate in the name of vendor is acceptable. In the absence of such material test certificate, one sample per lot (lot means all material having same heat mark/material specification) is to be tested for chemical and physical properties. Chemical and physical test shall be carried out in NPCIL approved/acceptable labs only. The Contractor shall submit all material verification reports and test reports to NPCIL Q.S for checking/verification and clearance before proceeding with manufacturing.
- 5) All test reports, test certificates and inspection reports shall be reviewed and accepted by Manufacturer/Main contractor before submitting the same for verification by Purchaser.
- 6) Source of raw material shall be informed to NPCIL in advance and consent shall be taken prior to proceed with the job.
- 7) Heat treatment shall be carried out in calibrated furnaces only.
- 8) Calibrated instruments shall be used during inspection, examination and testing.
- 9) The Contractor/ Manufacturer shall prepare 'History Docket' for the items supplied, compiling various inspection/ test reports and also other relevant documents as per the respective specification, and submit to NPCIL QS prior to issue of final shipping release note against the QA reference no. The Cover sheet & contents sheet of 'History Docket' shall be finalized during QAP approval stages.
- 10) After completion of each stage, all concerned persons shall sign the QAP against each stage inspection. The original QAP shall be kept with vendor till the final stage is completed and signed by all concerned. This document shall also be one of the basis for issuing the SR. The final signed QAP shall be part of History Docket.

• Any deviation to this QAP shall be brought out by Vendor in his offer failing which this QAP shall be complied fully.

				<b>LEGEND:</b> * RECORDS, IDENTIFIED WITH "TICK" (√) SHALL BE ESSENTIALLY INCLUDED BY SUPPLIER IN QA DOCUMENTATION ** M: SUPPLIER B: BHEL, N: NPCIL
Prepared	Reviewed & Approved	Reviewed & Approved	Reviewed & Approved	P: PERFORM, R: REVIEW W: WITNESS AND H: HOLD TC: TEST CERTIFICATE RD: RECORD
Supplier's Name		BHEL	NPCIL	



An ISO 9001  
Company

**Bharat Heavy Electricals Limited**  
(High Pressure Boiler Plant)  
Tiruchirappalli-620 014, Tamil Nadu, India  
Dept: MATERIALS MANAGEMENT/BOI

**Annexure – A- Terms and Conditions**

**ACCEPTANCE OF TECHNO - COMMERCIAL TERMS AND CONDITIONS BY THE BIDDERS**

<b>Description of the Equipment and Scope of work:</b>		<b>Supply of Silver Gaskets for 700MWe SG</b>
<b>Projects</b>		<b>NPCIL 700MW FLEET SG (D167)</b>
<b>BHEL Tender No. &amp; Date</b>		<b>1802300011 dated 20.02.2023</b>
<i>To be filled by bidder</i>		
<b>Name of the firm (Bidder)</b>		:
<b>Offer reference</b>		:
<b>Address</b>		:
<b>Contact details</b>		<u><b>Contact person 1</b></u> <b>Name:</b> <b>Designation:</b> <b>Office Phone:</b> <b>Mobile:</b> <b>e-mail:</b> <u><b>Contact person 2</b></u> <b>Name:</b> <b>Designation:</b> <b>Office Phone:</b> <b>Mobile:</b> <b>e-mail:</b>
<b>Sl. No.</b>	<b>Terms and conditions</b>	<b>Vendor's confirmation</b>
1 (a)	<b>Pre-qualification requirement (PQR):</b> Offer shall be considered only if bidder is meeting Tender Prequalification requirement (Annexure-B). Vendor to comply with Pre-Qualification requirement of the tender and submit along with their technical bid - the credentials and other documents as indicated in the PQR in the format prescribed. Otherwise their offer will get rejected.	
1 (b)	<b>Technical Requirements:</b> Supplier should conform to the requirements of: Specification PC-M-00069 Rev.00 and Drawings 3-93-172-05573/00 & 3-93-172-05575/00. Supplier to give clause by clause confirmation for all relevant clauses mentioned in technical specification PC-M-00069 Rev.00.	
1 (c)	Supplier has to submit their Quality Assurance Plan (QAP) in line with Annexure-C (Generic Quality plan), related test procedures and other documents based on the specification for approval from BHEL & NPCIL. The actual production of material is permitted only after approval of Quality Assurance Plan (QAP) and test procedures by BHEL and NPCIL.	

1 (d)	Inspection agencies for indigenous supply of materials are BHEL and NPCIL. Inspection agency for imported supplies are BHEL and NPCIL/ third party inspection (TPI) agency appointed/ authorized by NPCIL. In case of order, vendor to give the inspection notification for all witness test as per the QP for BHEL/NPCIL/TPI 3 working days before date of inspection.	
1 (e)	Chemical composition and mechanical tests to be carried out in NABL accredited (or) ISO /IEC 17025 compliant laboratories by supplier.	
1 (f)	Supplier shall submit Test Certificates of finished materials for our review. Dispatch clearance will be given after acceptance of Test Certificates by BHEL & NPCIL.	
1 (g)	Three sets of documents containing (i) Test Certificates, (ii) Approved quality documents and test procedures, (iii) Design Change Requisitions (if any) and (iv) Drawings etc. to be provided along with the supply of items.	
1 (h)	<b>Evaluation method:</b> The tender will be evaluated on total package basis. Evaluation and L1 identification shall be on total landed cost to BHEL including all cost up to destination. Currency of evaluation shall be <b>INR</b> . Rate quoted in Foreign currencies will be converted to INR by multiplying with the Exchange rate (SBI TT Selling rate) as on the technical bid opening date. If the date of opening happens to be a bank holiday, then the forex rate as on previous bank (SBI) working day shall be taken.	
1 (i)	Vendor shall quote as per the enclosed price Schedule format only. Quantities indicated in the enquiry, may be revised (increased or decreased), based on BHEL/NPCIL requirement. Quantity being procured will be confirmed before price bid opening.	
2 (a)	<b>Firm Price:</b> The quoted / finalised rates shall be Firm till execution of the supplies. Offer with PVC clause will not be considered.	
2 (b)	The Tender will be operated in two part bid system. One-part consisting of PQR, Technical bid with Commercial terms & conditions and other part is Price Bid. Based on the PQR compliance, technical suitability, vendors will be short-listed. Final acceptance of the Technical Bid will however, is based on NPCIL recommendation. The price Bid of short listed vendors will be opened on a suitable date with due intimation to vendors. Reverse Auction is applicable for this tender.	
2 (c)	<b>REVERSE AUCTION:</b> <i>BHEL shall be resorting to Reverse Auction (RA) (Guidelines as available on <a href="http://www.bhel.com">www.bhel.com</a>) for this tender. RA shall be conducted among all the techno- commercially qualified bidders. Price bids of all techno-commercially qualified bidders shall be opened and same shall be considered as initial bids of bidders in RA. In case any bidder(s) do(es) not participate in online Reverse Auction, their sealed envelope price bid along with applicable loading, if any, shall be considered for ranking.</i>	

<p>3</p>	<p><b>Delivery term:</b>  <b>Indigenous Suppliers</b>                  The quote shall be on FOR <b>BHEL Trichy stores</b> basis inclusive of Packing, forwarding, Freight.                  Transit Insurance is under BHEL scope.  <b>Import Supplier:</b>                  Import vendors to submit offers on CFR (Cost &amp; Freight), Chennai port (LILO – Liner in Liner Out) basis. Port of loading should be indicated without fail. Port of discharge should be Chennai.</p>													
<p>4 (a)</p>	<p><b>Payment Terms (Indigenous):</b>                  100% direct payment through EFT within 45 days for MSE Vendors from the date of receipt and acceptance of materials against 10% PBG.                  100% direct payment through EFT after 60 days for Medium Vendors and 90 days for Non-MSE vendors from the date of receipt and acceptance of materials and against 10% PBG.</p> <p><b>Payment Terms (Import):</b></p> <p><b>Option:1:</b>                  BHEL Payment term is 100% payment on CAD basis after 90 days from the date of receipt of documents, specified in PO, at BHEL bank and against 10% PBG. Respective bank charges to respective account.</p> <p><b>Option:2:</b>                  If supplier insists for LC, only Usance LC with 120 days credit will be opened one month prior to material readiness. Hence, supplier shall intimate the material readiness accordingly for opening of LC. LC validity period will be 90 days and for any extension, applicable charges will be to supplier's account.</p> <p>Any deviation in the above payment term will attract loading as mentioned below.</p> <p>MCLR rate of SBI p.a. + 6% (as applicable on the date of bid opening. Techno-commercial bid opening in case of two part bids) shall be considered for loading for the period of relaxation sought by bidders subject to competent authority approval.</p> <p>Example of the same is provided below.</p> <table border="1" data-bbox="300 1771 1145 1977"> <thead> <tr> <th>Payment term</th> <th>Relaxation period (days)</th> <th>Loading (@ MCLR 8.05% p.a. + 6%)</th> </tr> </thead> <tbody> <tr> <td>LC 90 days</td> <td>30</td> <td>1.15%</td> </tr> <tr> <td>LC 60 days</td> <td>60</td> <td>2.31%</td> </tr> <tr> <td>LC 30 days</td> <td>90</td> <td>3.46%</td> </tr> </tbody> </table>	Payment term	Relaxation period (days)	Loading (@ MCLR 8.05% p.a. + 6%)	LC 90 days	30	1.15%	LC 60 days	60	2.31%	LC 30 days	90	3.46%	<p>Option-1/Option-2 (Import vendors shall mark the payment option)</p>
Payment term	Relaxation period (days)	Loading (@ MCLR 8.05% p.a. + 6%)												
LC 90 days	30	1.15%												
LC 60 days	60	2.31%												
LC 30 days	90	3.46%												

4 (b).	<p><b>Performance Bank Guarantee:</b> BHEL require a performance Bank Guarantee for the due performance of Manufacturing and supply of Silver Gaskets for 700MWe SG under this contract to a value of 10% of Order value covering the Warranty period. The PBG shall be in BHEL format (Format attached) which is to be opened in any one of the banks mentioned under List of Consortium Banks attachment. All banks charges shall be to vendor account only. Performance bank guarantee shall have minimum claim period of 3 to 6 months from the date of expiry.</p>	
5 (a).	<p><b>Liquidated damages (LD):</b></p> <ul style="list-style-type: none"> <li>a) Time is the essence of the contract.</li> <li>b) The ordered items shall be delivered as per the delivery period mentioned in the Purchase Order.</li> <li>c) In case the supplier supplies the ordered items beyond the delivery period specified, Liquidated Damages -LD - as detailed below shall be will be levied from the supplier without prejudice to any other relief /compensation available to BHEL, Tiruchirapalli under any other condition of the contract/applicable legal provisions.</li> <li>d) Failure to dispatch the materials in the time as per the delivery quoted in our Purchase Order(PO) would make the supplier liable to an un-conditional LD at the rate of LD at the rate of 0.5% of the total order value per week or part thereof subject to a maximum of 10% of the total Purchase order value.</li> <li>e) Any deviation from the above LD clause, loading will be applied to the extent to which it is not agreed by the bidder (at offered value).</li> <li>f) Indigenous: For “FOR Delivery terms”, Lorry way bill date will be taken for LD calculation for cases where e-way bill is not mandatory. Wherever E Way Bill is involved, the date of commencement of movement of vehicle as reflected in E way Bill [the ‘Valid from’ date in the E way Bill] will be taken for LD calculation</li> <li>g) Import: For CFR terms, BL date will be considered for LD calculation.</li> </ul>	
5(b).	<p>In case of PO placement, required documents have to be submitted for approval within 45 days from the date of PO &amp; reply for any further clarification has to be within 7 days. Any delay beyond the above specified period will be considered during LD calculation.</p>	
6 (a).	<p><b>Warranty Period:</b> Vendor shall give warranty against design &amp; manufacturing defects for a period of 12 months from the date of commissioning or 18 months from the date of supply whichever is earlier.</p>	
6 (b).	<p><b>Repair &amp; replacements:</b> Within the warranty period, vendor has to replace / rectify the defective/ damaged items on free of cost within a reasonable time of reporting from our end. All incidental charges like freight, insurance and customs duty are to your account only. The defective parts and components shall be collected by your Indian agent or / authorized person, only after completing the replacement / repairs. If the supplier fails to replace / rectify the defective/ damaged</p>	

	<p>items on free of cost within 60 days of reporting from our end, the same shall be treated as failure to execute the contract and actions as per the Guidelines for Suspension of Business Dealings with Suppliers /Contractors available in the webpage: <a href="http://www.bhel.com/vender_registration/vender.php">http://www.bhel.com/vender_registration/vender.php</a>. would be taken against such supplier without prejudice to the other remedies available to BHEL under the contract and law in this regard.</p>	
6 (c).	No Deviation is permitted. If still vendor offered any deviation on the warranty period, it may lead to rejection of offer.	
7.	<p><b>Acceptance of materials supplied:</b></p> <p>i. The supply shall be strictly as per the specifications in the tender /purchase order.</p> <p>ii. Delivery of the ordered items as per the delivery terms in the Purchase Order does not automatically constitute acceptance of the delivered items.</p> <p>iii. The acceptance or otherwise of the delivered items at BHEL /Stores/Trichy will be separately communicated to the supplier by BHEL either through B2B portal or through e-mail within 120 days from the delivery of items or delivery of the required test certificates /other documents whichever is later.</p> <p>iv. In case of rejection of the delivered items at BHEL/Stores/ Trichy, either part or full, the vendor shall replace the rejected items as per the specification in the Purchase order/tender at their cost within specified days/months of communication of rejection to the supplier.</p> <p>v. In case of rejection of the delivered items, either part or full, if the supplier fails to replace the rejected items within the specified days/months of communication of the rejection, the same shall be treated as failure to execute the contract and actions as per the Guidelines for Suspension of Business Dealings with Suppliers /Contractors available in the webpage:</p> <p><a href="http://www.bhel.com/vender_registration/vender.php">http://www.bhel.com/vender_registration/vender.php</a>. would be taken against such supplier</p>	
8.	<p><b>Duty benefits for import vendors</b></p> <p>a) Whether PTA/ CEPA or any other agreement/treaty between respective Governments/Countries exists and the same is applicable for your supplies w.r.t this Enquired Items/tender.</p> <p>b) If yes, mention the Concessional Customs Duty (Such Duty Benefits) %</p> <p>c) Documentary proof for the applicable Concessional Customs Duty (eg. PTA/ CEPA or other agreement) shall be submitted along with the Part-1 bid.</p>	<p>YES / NO</p> <p>SUBMITTED/NOT SUBMITTED</p>

	<p>d) Relevant documents and details to avail the above concessional duty benefits by BHEL shall be submitted by the supplier along with dispatch documents.</p> <p>e) In the event of seller failing to provide appropriate documents along with dispatch documents for purchasers to avail disclosed concessional duty benefits in India, financial loss, so incurred, will be to the seller's account.</p> <p><b>Note:</b> Evaluation of the Price bids will be based on the above details only and unless mentioned/furnished by the vendor, Customs Duty benefit will not be applied for evaluation purposes.</p>	<p>CONFIRMED/NOT CONFIRMED</p> <p>CONFIRMED/NOT CONFIRMED</p>
10.	<p><b>Risk purchase clause:</b></p> <p>a. In the event of any successful Tenderer's failure to fulfil any of the tender / Contract obligations including supply of whole or any part of the ordered items as per Contract / Agreement, BHEL has the right to terminate the contract and purchase from elsewhere, at the risk and cost of the defaulted supplier, either the whole of the goods or any part which the supplier has failed to deliver or dispatch within the time stipulated in the contract or if the same were not available, the best and nearest available substitute thereof. The supplier shall be liable for the additional expenditure/difference in Cost, if any, including consequential losses which BHEL may sustain by reason of risk purchase in addition to the applicable LD as per the Purchase order/contract.</p> <p>b. The decision of BHEL with regard to the additional expenditure / difference in cost and consequential losses incurred by BHEL shall be final and binding on the supplier.</p> <p>c. The amount recoverable under risk purchase shall be recovered from the defaulted supplier in all or any of the following manners:</p> <ul style="list-style-type: none"> <li>• from dues available in the form of Bills payable to defaulted supplier, SD, BGs against the same contract.</li> <li>• from the dues payable to defaulted supplier against other contracts in the same Region/Unit /any other region/unit In-case recoveries are not possible with any of the above available options, Legal action shall be initiated for recovery against defaulted supplier.</li> </ul> <p>GST is applicable on amount recoverable from vendors under risk purchase clause as per Govt. Circular No. 178/10/2022-GST dt. 03.08.2022.</p>	
11.	<p><b>Suspension of Business Dealings:</b></p> <p>The offers of the bidders who are under suspension as also the offers of the bidders, who engage the services of the banned firms, shall be rejected. The list of banned firms is available on BHEL web site <a href="http://www.bhel.com">www.bhel.com</a>.</p> <p>If any bidder/ supplier/ contractor during pre-tendering/ tendering/ post tendering/ award/ execution/ post-execution stage indulges in mal-practices, cheating, bribery, fraud or and other misconduct or formation of cartel so as to influence the bidding process or influence the price or acts or omits in any manner which tantamount to an offence punishable under any provision of the Indian Penal Code, 1860 or any other law in force in India or does anything which is</p>	

	actionable under the Guidelines for Suspension of Business dealings, action may be taken against such bidder/ supplier/ contractor as per extant guidelines of the company available on www. bhel.com and/or under applicable legal provisions. Guidelines for suspension of business dealings is available in the webpage.	
12.	<p><b>Delivery Period:</b>  Delivery Period shall be 30 weeks from document approval.  The delivery dates mentioned above and given in the PO are indicative only. The exact delivery date will be intimated by BHEL while giving dispatch clearance.  The supplier shall keep the manufactured items safely till the dispatch clearance is given by BHEL.</p>	
13.	<p><b>Documents are to be submitted along with technical bid (Part-1)</b></p> <ol style="list-style-type: none"> <li>01. Covering letter.</li> <li>02. Unpriced offer.</li> <li>03. Details are per Sl. No. 8 of the technical specification PC-M-00069.</li> <li>04. Filled up Techno Commercial Terms and condition sheet (Annexure-A).</li> <li>05. Filled Pre-Qualification requirement (Annexure- B) along with supporting documents.</li> <li>06. Catalogue's</li> <li>07. Detailed BOM of the package with weight details of each item.</li> <li>08. Third party non-disclosure agreement</li> <li>09. MSE documents (if applicable)</li> <li>10. Make in India self certification in the attached format (if applicable)</li> <li>11. Filled up and Signed No Deviation Format</li> <li>12. Filled up and Signed Integrity Pact</li> <li>13. Documents in support of duty benefits (if applicable)</li> </ol> <p><b>Documents are to be submitted along with Price bid (Part-2)</b></p> <ol style="list-style-type: none"> <li>01. Priced offer as per the format attached with enquiry.</li> </ol> <p><b>Note:</b> All the pages of documents are to be signed and sealed by authorized signatory of the company. Any query during enquiry stage shall be replied within three days failing which offer may be rejected as non-responsive.</p>	
14.	<p><b>Offer Validity:</b>  120 days minimum from techno commercial bid opening ( Part-1)</p>	
15.	<p><b>O &amp; M manuals:</b> Detailed O&amp;M manuals shall be furnished. Three soft copies of O&amp;M manuals in (CD ROM) compact disc to be submitted. One hard copy and one CD should be sent along with transit assembly to site directly.</p>	
16.	<b>Kindly indicate the GST No of your Firm</b>	
17.	<b>Kindly Indicate the HSN Code for all items</b>	
18.	<b>Please indicate the applicable GST % ( IGST )</b>	
19.	Response to Tenders for Indigenous supplier will be entertained only if the vendor has a valid GST registration Number (GSTIN) which should be clearly mentioned in the offer. If the dealer is exempted	

	from GST registration, a declaration with due supporting documents need to be furnished for considering the offer. Dealers under composition scheme should declare that he is a composition dealer supported by the screen shot taken from GSTN portal. The unregistered dealer as well as the composition dealer has to submit an undertaking stating that they will not claim GST during the execution of the contract even if their status under GST changes to regular tax payer. The dealer has to submit necessary documents if there is any change in status under GST.	
20.	Supplier shall mention their GSTIN in all their invoices (incl. credit Notes, Debit Notes) and invoices shall be in the format as specified/prescribed under GST laws. Invoices shall necessarily contain Invoice number (in case of multiple numbering system is being followed for billing like SAP invoice no, commercial invoice no etc., then the Invoice No. which is linked/uploaded in GSTN network shall be clearly indicated), Billed to party (with GSTIN) & Shipped to party details, item description as per PO, Quantity, Rate, Value, applicable taxes with nomenclature (like IGST, SGST, CGST & UTGST) separately, HSN/ SAC Code, Place of Supply etc. Wherever E-Invoice is applicable, the tax invoice/ CN / DN submitted by the vendor must contain the QR code generated in E-Invoice Portal & IRN.	
21.	All invoices shall bear the HSN Code for each item separately (Harmonized System of Nomenclature)/ SAC code (Services Accounting Code)	
22.	Invoices will be processed only upon completion of statutory requirement and further subject to following:  i. Vendor declaring such invoice in their GSTR-1 Return/ IFF ii. Receipt of Goods or Services and Tax invoice by BHEL	
23.	As the continuous uploading of tax invoices in GSTN portal (in GSTR-1/ IFF) is available for all (i.e. both Small & Large) tax payers, all invoices raised on BHEL may be uploaded immediately in GST portal on dispatch of material /rendering of services. The supplier shall ensure availability of Invoice in GSTN portal before submission of invoice to BHEL. Invoices will be admitted by BHEL only if the invoices are available in GSTN portal (in BHEL's GSTR-2A/ GSTR-2B).	
24.	In case of discrepancy in the data uploaded by the supplier in the GSTN portal or in case of any shortages or rejection in the supply, then BHEL will not be able to avail the tax credit and will notify the supplier of the same. Supplier has to rectify the data discrepancy in the GSTN portal or issue credit note or debit note (details also to be uploaded in GSTN portal) for the shortages or rejections in the supplies or additional claims, within the calendar month informed by BHEL.	
25.	In cases where invoice details have been uploaded by the vendor but failed to remit the GST amount to GST Department (Form PMT-08 or Form GST RET-01 to be submitted) within stipulated time, then GST paid on the invoices pertaining to the month for which GST return not filed by the vendor will be recovered from the vendor along with the applicable interest (currently 24% p.a) and all subsequent bills of the	

	vendor will not be processed till filing of the GST return by the vendor	
26.	In case GST credit is denied to BHEL due to non-receipt or delayed receipt of goods and/ or tax invoice or expiry of timeline prescribed in GST law for availing such ITC, or any other reasons not attributable to BHEL, GST amount claimed in the invoice shall be disallowed to the vendor.	
27.	Where any GST liability arising on BHEL under Reverse Charge (RCM), the vendor has to submit the invoices to BHEL well within the timeline prescribed in GST Law, to enable BHEL to discharge the GST liability. If there is a delay in submission of invoice by the vendor resulting in delayed payment of GST by BHEL along with Interest, then such Interest payable or paid shall be recovered from the vendor.	
28.	BLANK	
29.	GST TDS will be deducted as per Section 51 of CGST Act 2017 and in line with Notification 50/2018 –Central Tax dated 13.09.2018. GST TDS certificate will be generated in GSTN portal subsequent to vendor accepting the TDS deduction in the GSTN portal & the vendor can directly download the Certificate from the GSTN Portal.	
30.	<p><b>MSE VENDOR:</b></p> <p><i>i. If L1 vendor is an MSE vendor entire project package will be ordered on L1 vendor.</i></p> <p><i>ii. If a Non MSE vendor is coming as L1, then L1 prices will be counteroffered on MSE vendor who is quoting price within the price band L1+15% and if they are agreeing, purchase order will be awarded for full/complete supply of total tendered value to MSE.</i></p> <p><i>iii. If more than one MSE vendors are available in the L1+15% price band then lowest of the MSE vendor will be selected for counteroffering. If lowest MSE vendor is not accepting it will be counteroffered to the next MSE vendor in the price band and so on.</i></p> <p><i>iv. Finally if none of the MSE vendor in the price band is not accepting it will be ordered on L1 non MSE vendor.</i></p> <p>Payment for MSE Indigenous vendors will be as per MSMED Act, 2006</p> <p>MSE suppliers can avail the intended benefits only if they submit along with the offer, attested/notarized copy of <b>Udyam Registration certificate</b>.</p> <p><b>Non submission of such documents will lead to consideration of their bid at par with other bidders. No benefit shall be applicable for this enquiry, in case of any deficiency in the above required documents or in case the documents are not submitted before price bid opening. If the tender is to be submitted through e-procurement portal, then the above required documents are to be uploaded on the portal even if submitted earlier.</b></p>	

31.	<p><b><u>Make in India:</u></b> For this procurement, the local content to categorize a supplier as a Class I local supplier/ Class II local Supplier/ Non- Local supplier and purchase preference to Class I local supplier, is as defined in Public Procurement (Preference to Make in India), Order 2017 dated 04.06.2020 issued by DPIIT. In case of subsequent orders issued by the nodal ministry, changing the definition of local content for the items of the NIT, the same shall be applicable even if issued after issue of this NIT, but before opening of Part-II bids against this NIT.</p> <p><b>The 'Class-I local supplier'/ 'Class-II local supplier' shall be required to provide a certificate from the statutory auditor or cost auditor of the company (in the case of companies) or from a practicing cost accountant or practicing chartered accountant (in respect of suppliers other than companies) giving the percentage of local content.</b></p>	
32.	<p>Orders issued by Govt. of India with respect to Restriction under Rule 144 (xi) of GFR on procurement from bidders representing countries sharing land border will be applicable for this tender. In case of subsequent orders issued by Govt. of India regarding procurement from bidders representing countries sharing land border, the same shall be applicable even if issued after issue of this NIT.</p>	
33.	<p><b><u>Packing Requirements (for indigenous vendors):</u></b> Packing shall be as per Sl. No. 12 of the technical specification PC-M-00069.</p> <p><b><u>Packing Requirements (for import vendors):</u></b> Packing shall be as per Sl. No. 12 of the technical specification PC-M-00069. In addition, Packing shall be sea worthy.</p>	
34.	<p>The preferred shipment mode “<b>Containerized Cargo or Break Bulk</b>” shall be specified clearly in the offer.</p> <p><b><u>FOR CFR INCO TERMS – CONTAINERIZED CARGO</u></b></p> <ul style="list-style-type: none"> <li>○ For CFR terms, moved through CONTAINERS (Suppliers should clearly specify this in their offer) it would be presumed by BHEL that the freight charges quoted is on LILO (LINER IN LINER OUT) basis including extra charges, if any, like Container Imbalance Charges, Trade Imbalance charges or any other charges payable to the Liner. No other charges other than the quoted Freight rate will be paid by BHEL excepting applicable Terminal Handling Charges, Container cleaning Charges, DO charges to Shipping Liner at Discharge Port. 14 FREE DAYS FOR Container detention shall be provided.</li> <li>○ In case of shipment through Containers on CFR basis, the BL should bear the endorsement that “14 free days for Container Detention is applicable”.</li> </ul> <p><b><u>FOR BREAKBULK CARGO:</u></b></p> <ul style="list-style-type: none"> <li>○ For CFR terms, moved through BREAK BULK BASIS (Suppliers should clearly specify this in their offer) it would be presumed by BHEL that the freight charges quoted is on LILO (LINER IN LINER OUT) basis.</li> </ul>	

- The materials will be Custom cleared from Port itself.

**Important Information for Import Suppliers:**

- Indian Customs has imposed a penalty on late filing of Bill of Entries (Air/Sea Shipments) by the importer. The maximum free time allowed is 24 hrs from the time of arrival of cargo at final port of discharge. At present penalty is Rs.5000/- per day (for Initial 03 days) & Rs.10000/- per day (thereafter). Hence the supplier shall submit the Non-Negotiable Documents (Bill of Lading, Commercial Invoice, Packing List, Certificate of Origin, etc.) either by email or post/courier to BHEL well before the landing of cargo at final port of discharge.
- In case of any penalty due to late filing of Bill of entry for reasons attributable to suppliers (as listed below), the same will be recovered from the bills of supplier:
  - Non availability of Non-Negotiable Documents (NNDs) before the cargo arrival
  - Discrepancy in documents
  - Short landing of Consignments (For shipments on CFR–Chennai Port)
- For all the shipments for the contracts (POs) finalized on CFR-Chennai Port basis,
  - Delivery Orders involving multiple agencies like liners/freight forwarders are not allowed. To avoid any delay, BHEL prefers Single agency office at the final discharge Port (Chennai) for issuing the Delivery Order to BHEL.
  - The detention/demurrage charges arise due to the delay in collection of Delivery Orders from multiple agencies of liner/freight forwarder also whose offices are not at available Chennai, the same amount will be deducted from Supplier's bills.
  - Apart from the Terminal Handling Charges, Container cleaning Charges & Delivery Order Charges at final port of discharge, any other charges will not be borne by BHEL.
  - The liner/freight forwarders shall be informed by the Vendor not to claim any additional charges (like charges listed below) for issuing Delivery Order. In case if the liner/freight forwarder claims such charges, the same amount will be deducted from the Vendor bills with/without any prior intimation in order to avoid the delay in Customs clearance. The likely additional/hidden charges are listed below
    - CIC - Container Imbalance Charges/Surcharges
    - EIC - Equipment Imbalance Charge/Surcharges
    - CAF - Container/Currency Adjustment Factor
    - BAF - Bunker adjustment Factor
    - RDS - Rupee Depreciation Surcharge
    - CDS - Currency Depreciation Surcharge
    - PCS - Port Congestion Surcharge
    - LSS - Low Sulphur Surcharge
    - Devanning Charges

	<p><b><u>Transport Conditions for Import:</u></b>                  The Original Documents (Bill of Lading, Invoice, Packing List, Certificate of Origin &amp; Test Certificate) shall reach BHEL well in advance before the vessel arrival. The soft copies of the above shall be forwarded to BHEL immediately after shipment.</p> <ul style="list-style-type: none"> <li>○ 14 FREE DAYS for Container detention at final port of destination shall be provided and the same to be endorsed in the Bill of Lading. If there is no free day or less than 14 free days provided by the supplier, the actual cost incurred towards detention charges due to non-availability of above said free days will be recovered from the supplier Invoice.</li> <li>○ In the event of delayed submission of documents/ non-submission of documents by the supplier as per the mutually agreed terms, an amount up to 5% of the invoice value will be retained towards detention/ demurrage &amp; other charges and the difference if any between actual charges and recovery will be settled separately through supplementary invoice.</li> <li>○ In such cases, the Supplier shall authorize the Steamer / Shipping agent / transporter to freely release the consignment to BHEL by providing a “Surrender Bill of Lading”.</li> <li>○ Otherwise, No-objection Certificate shall be issued to the Liner, authorizing BHEL to get the Delivery Order without producing the Original Bill of Lading.</li> <li>○ This is required to ensure avoidance of detention/ demurrage at Chennai Sea-port that may arise in case of delayed presentation of documents by the Seller.</li> </ul>	
<p>35.</p>	<p>As per extant provisions of Income Tax Act,1962 in India, foreign suppliers have to submit the following documents to avail benefits under DTAA at time of each dispatches, failing which TDS will be applicable considering Business Income in India. (Current TDS rate @ 40% as per the extant law provisions) plus applicable surcharge and cess is to be deducted u/s. 195 of I.T Tax Act.</p> <ul style="list-style-type: none"> <li>● Valid Tax Residency Certificate issued by Govt / Tax agency of country.</li> <li>● Form 10F duly filed signed. (sample copy as per Annexure-DT1)</li> <li>● No PE and No Business connection declaration in mills letter head.</li> <li>● Declaration of No Significant Economic Presence (SEP) in India as per Indian I.T Rule 11UD &amp; indemnity to pay taxes at later stages on demand.</li> <li>● Self-declaration that Non-resident is eligible to obtain benefits of relevant DTAA between India and Supplier’s country. (sample copy as per Annexure-DT2)</li> </ul>	

36.	<p><b><u>Fraud Prevention Policy</u></b>  Bidder along with its associate /collaborators /sub-contractors /sub-vendors / consultants / service providers shall strictly adhere to BHEL Fraud Prevention Policy displayed on BHEL website <a href="http://www.bhel.com">http://www.bhel.com</a> and shall immediately bring to the notice of BHEL Management about any fraud or suspected fraud as soon as it comes to their notice.</p>	
37.	<p><b><u>Cartel Formation</u></b>  All the firms should desist from forming cartel as the practice is prohibited under Section 3(3) (a) &amp; (d) of the competition Act 2002. If any such instance is observed during this tender will attract disciplinary action as per BHEL policies.  The Bidder declares that they will not enter into any illegal or undisclosed agreement or understanding, whether formal or informal with other Bidder(s). This applies in particular to prices, specifications, certifications, subsidiary contracts, submission or non-submission of bids or any other actions to restrict competitiveness or to introduce cartelization in the bidding process. In case, the Bidder is found having indulged in above activities, suitable action shall be taken by BHEL as per extant policies/guidelines.</p>	
38.	<p><b><u>Resolution of Disputes</u></b>  The Parties agree that if at any time (whether before, during or after the arbitral or judicial proceedings), any Disputes (which term shall mean and include any dispute, difference, question or disagreement arising in connection with construction, meaning, operation, effect, interpretation or breach of the contract/tender which the Parties are unable to settle mutually), arise inter-se the Parties, the same may, be referred by either party to Conciliation to be conducted through Independent Experts Committee to be appointed by competent authority of BHEL from the BHEL Panel of Conciliators.</p> <p>The proceedings of Conciliation shall broadly be governed by Part-III of the Arbitration and Conciliation Act 1996 or any statutory modification thereof.</p> <p>Notes:</p> <ol style="list-style-type: none"> <li>1. No serving or a retired employee of BHEL/Administrative Ministry of BHEL shall be included in the BHEL Panel of Conciliators.</li> <li>2. Any other person(s) can be appointed as Conciliator(s) who is/are mutually agreeable to both the parties from outside the BHEL Panel of Conciliators.</li> </ol> <p>The proceedings of Conciliation shall broadly be governed by Part-III of the Arbitration and Conciliation Act 1996 or any statutory modification thereof and as provided in Annexure X to this Terms and conditions.</p> <p>The Annexure X together with its appendices will be treated as if the same is part and parcel hereof and shall be as effectual as if set out herein in this terms and conditions.</p>	

Except as provided elsewhere in this Contract, in case amicable settlement is not reached between the parties, in respect of any dispute or difference; arising out of the formation, breach, termination, validity or execution of the Contract; or, the respective rights and liabilities of the Parties; or, in relation to interpretation of any provision of the Contract; or, in any manner touching upon the Contract, then, either Party may, by a notice in writing to other Party refer such dispute or difference to sole arbitration of an arbitrator appointed as per the Arbitration and Conciliation Act, 1996 (India) or statutory modification or re-enactment thereof and the rules made thereunder and for the time being in force.

The Arbitrator shall pass a reasoned award and the award of the Arbitrator shall be final and binding upon the parties.

This contract shall be governed, construed and interpreted in accordance with the laws of India.

Subject as aforesaid, the provision of Arbitration & Conciliation Act 1996 (India) or statutory modification or re-enactment thereof and the rules made thereunder and for the time being in force shall apply to the arbitration proceeding under this clause.

The seat of arbitration shall be Trichy, Tamil Nadu, India  
The cost of arbitration shall be borne as per the award of the Arbitrator.

Subject to arbitration in terms of clause above, the Courts at Trichy, Tamil Nadu, India shall have exclusive jurisdiction over any matter arising out of or in connection with this Contract.

Notwithstanding the existence or any dispute or difference and/or reference for the arbitration, the vendor shall proceed with and continue without hindrance the performance of its obligation under this Contract with due diligence and expedition in a professional manner except where the Contract has been terminated by either Party in terms of this Contract.

In Case of Contract with Public Sector Enterprise (PSE) or a Government Department, the following shall be applicable:

In the event of any dispute or difference relating to the interpretation and application of the provisions of commercial contract(s) between Central Public Sector Enterprises (CPSEs)/Port Trusts inter se and also between CPSEs and Government Departments/Organizations (Excluding disputes concerning Railways, Income Tax, Customs & Excise Departments, such dispute or difference shall be taken up by either party for its resolution through AMRCD as mentioned in DPE OM No. 05/003/2019-FTS-10937 dtd. 14th December, 2022 and the decision of AMRCD on the said dispute will be binding on both the parties.

39.	<p><b><u>Force Majeure clause</u></b></p> <p>a. Notwithstanding the provisions contained in other clauses, the supplier shall not be liable for imposition of any such sanction so long the delay and/or failure of the supplier in fulfilling its obligations under the contract is the result of an event of Force Majeure. For purposes of this clause, Force Majeure means an event beyond the control of the supplier and not involving the supplier's fault or negligence and which is not foreseeable and not brought about at the instance of the party claiming to be affected by such event and which has caused the non – performance or delay in performance. Such events may include, but are not restricted to, wars or revolutions, hostility, acts of public enemy, civil commotion, sabotage, fires, floods, explosions, epidemics, quarantine restrictions, strikes excluding by its employees, lockouts excluding by its management, freight embargoes and Acts of GOD.</p> <p>b. If a Force Majeure situation arises, the supplier shall promptly notify the Purchaser/Consignee in writing of such conditions and the cause thereof within twenty-one days of occurrence of such event. Unless otherwise directed by the Purchaser/Consignee in writing, the supplier shall continue to perform its obligations under the contract as far as reasonably practical, and shall seek all reasonable alternative means for performance not prevented by the Force Majeure event.</p> <p>c. If the performance in whole or in part or any obligation under this contract is prevented or delayed by any reason of Force Majeure for a period exceeding sixty days, either party may at its option terminate the contract without any financial repercussion on either side.</p> <p>d. In case due to a Force Majeure event the Purchaser/Consignee is unable to fulfil its contractual commitment and responsibility, the Purchaser/Consignee will notify the supplier accordingly and subsequent actions taken on similar lines described in above sub-paragraphs.</p>	
40.	<p><b>Set off :</b> BHEL shall have the right to recover any money which in the sole opinion of BHEL is due from the supplier from any money due to the supplier under this Contract or any other contract or from the Security Deposit/BG furnished by the supplier under this Contract or any other contract.</p>	
41.	<p><b><u>Conflict of Interest Among Bidders/Agents:</u></b></p> <p>A bidder shall not have conflict of interest with other bidders. Such conflict of interest can lead to anti-competitive practices to the detriment of Procuring Entity's interests. The bidder found to have a conflict of interest shall be disqualified. A bidder may be considered to have a conflict of interest with one or more parties in this bidding process, if:</p> <p>a. they have controlling partner (s) in common; or</p> <p>b. they receive or have received any direct or indirect subsidy/ financial stake from any of them; or</p> <p>c. they have the same legal representative/agent for purposes of this bid; or</p>	

	<p>d. they have relationship with each other, directly or through common third parties, that puts them in a position to have access to information about or influence on the bid of another Bidder; or</p> <p>e. Bidder participates in more than one bid in this bidding process. Participation by a Bidder in more than one Bid will result in the disqualification of all bids in which the parties are involved. However, this does not limit the inclusion of the components/ sub-assembly! Assemblies from one bidding manufacturer in more than one bid; or</p> <p>f. In cases of agents quoting in offshore procurements, on behalf of their principal manufacturers, one agent cannot represent two manufacturers or quote on their behalf in a particular tender enquiry. One manufacturer can also authorise only one agent/dealer. There can be only one bid from the following:</p> <ol style="list-style-type: none"> <li>1. The principal manufacturer directly or through one Indian agent on his behalf; and</li> <li>2. Indian/foreign agent on behalf of only one principal;</li> </ol> <p style="text-align: center;">or</p> <p>g. A Bidder or any of its affiliates participated as a consultant in the preparation of the design or technical specifications of the contract that is the subject of the Bid; or</p> <p>h. In case of a holding company having more than one independently manufacturing units, or more than one unit having common business ownership/management, only one unit should quote. Similar restrictions would apply to closely related sister companies. Bidders must proactively declare such sister/ common business/ management units in same/ similar line of business.</p>	
<b>Note.</b>	<ol style="list-style-type: none"> <li>1. In the event of our customer order covering this tender being cancelled /placed on hold / otherwise modified, BHEL would be constrained to accordingly cancel / hold / modify the tender at any stage of execution.</li> <li>2. BHEL may negotiate the L1 rate, if not meeting our budget / estimated cost. BHEL may re-float the tender opened, if L1 price is not acceptable to BHEL. Any deviation in specified commercial terms- Annexure-A, will lead to rejection of offer.</li> <li>3. BHEL reserves its right to reject an offer due to unsatisfactory past performance by the respective Vendor in the execution of any contract to any BHEL project / Unit.</li> <li>4. BHEL/NPCIL <b>will not provide</b> End Use and End User Certificates for supplies of the Items covered in this enquiry.</li> <li>5. <b>Any other Techno-Commercial Terms indicated by the vendor in their offer elsewhere will be ignored. BHEL will proceed with tender evaluation as per Annexure-A only.</b></li> </ol>	

## FORM NO. 10F

[See sub-rule (1) of rule 21AB]

**Information to be provided under sub-section (5) of section 90 or sub-section (5) of section 90A of the Income-tax Act, 1961**

I, ..... \*son/daughter of Shri..... in the capacity of ..... (designation) do provide the following information, relevant to the previous year..... \*in my case/in the case of..... for the purposes of sub-section (5) of \*section 90/section 90A:—

<i>Sl.No</i>	<i>Nature of information</i>	<i>:</i>	<i>Details #</i>
(i)	Status (individual, company, firm etc.) of the assessee	:	
(ii)	Permanent Account Number or Aadhaar Number of the assessee if allotted	:	
(iii)	Nationality (in the case of an individual) or Country or specified territory of incorporation or registration (in the case of others)	:	
(iv)	Assessee's tax identification number in the country or specified territory of residence and if there is no such number, then, a unique number on the basis of which the person is identified by the Government of the country or the specified territory of which the assessee claims to be a resident	:	
(v)	Period for which the residential status as mentioned in the certificate referred to in sub-section (4) of section 90 or sub-section (4) of section 90A is applicable	:	
(vi)	Address of the assessee in the country or territory outside India during the period for which the certificate, mentioned in (v) above, is applicable	:	

2. I have obtained a certificate referred to in sub-section (4) of section 90 or sub-section (4) of section 90A from the Government of ..... (name of country or specified territory outside India)

Signature: .....

Name: .....

Address: .....

Permanent Account Number or Aadhaar Number .....

**Verification**

I ..... do hereby declare that to the best of my knowledge and belief what is stated above is correct, complete and is truly stated.

Verified today the ..... day of.....

.....  
*Signature of the person providing the information*

Place: .....

**Notes :**

1. \*Delete whichever is not applicable.
2. #Write N.A. if the relevant information forms part of the certificate referred to in sub-section (4) of section 90 or sub-section (4) of section 90A.

## ANNEXURE- DT2

We do not wholly or partly carry on business in the Republic of India through a Permanent Establishment in India. Further we do not constitute any Permanent Establishment in India in accordance with the Article No. 5 of the DTAA between India and \_\_\_\_\_ (Supplier country name)

We also declare No Significant Economic Presence (SEP) in India as per Indian IT Rule 11UD and self-declare that No-resident is eligible to obtain benefits of relevant DTAA between India and \_\_\_\_\_

---

We do not have a business connection<sup>1</sup> in the Republic of India as per Section 9(1)(i) of the Act.

As and whenever we will constitute / establish any Permanent Establishment/ business connection in India or deemed to have a Permanent Establishment / business connection in India or in case it is held by Indian Income Tax Authorities that we have a Permanent Establishment / business connection in India (referred as 'event'), we will bring this to the knowledge of Bharat Heavy Electricals Limited before any subsequent payments are released by Bharat Heavy Electricals Limited or within 5 working days of any such event, whichever is earlier.

We hereby declare that whatever is stated above is true and correct. In the event there is any change in any of the facts stated above, we will bring this to the knowledge of Bharat Heavy Electricals Limited before any subsequent payments are released by Bharat Heavy Electricals Limited or within 5 working days of any such event, whichever is earlier.

Where any tax, interest, penalty is levied on Bharat Heavy Electricals Limited for non/lower withholding of taxes on account of the above declarations being incorrect, we, Name of vendor , hereby undertake that we shall reimburse Bharat Heavy Electricals Limited such amounts as would be demanded by the Tax Authorities along with Interest and Penalty.

### Explanation in foot mark

---

<sup>1 1</sup> The term 'business connection' shall include significant economic presence ("SEP") of a non-resident in India, w.e.f. 1 April 2021. As per Explanation 2A to Section 9(1)(i) of the Act read with Notification no. 41 of 2021, SEP for this purpose, shall mean:- (a) transaction in respect of any goods, services or property carried out by a non-resident with any person in India including provision of download of data or software in India, for which aggregate payments

**BRIEF PROCEDURE FOR CONDUCT OF CONCILIATION PROCEEDINGS**

1. The proceedings of Conciliation shall broadly be governed by Part-III of the Arbitration and Conciliation Act 1996 or any statutory modification thereof and as provided herein:
2. The party desirous of resorting to Conciliation shall send an invitation/notice in writing to the other party to conciliate specifying all points of Disputes with details of the amount claimed. The party concerned shall not raise any new issue thereafter. Parties shall also not claim any interest on claims/counter-claims from the date of notice invoking Conciliation till the conclusion of the Conciliation proceedings.
3. The party receiving the invitation/notice for Conciliation shall within 30 days of receipt of the notice of Conciliation intimate its consent for Conciliation along with its counter-claims, if any.
4. The Conciliation in a matter involving claim or counter-claim (whichever is higher) up to Rs 5 crores shall be carried out by sole Conciliator nominated by BHEL while in a matter involving claim or counter-claim (whichever is higher) of more than Rs 5 crores Conciliation shall be carried out by 3 Conciliators nominated by BHEL.
5. The Parties shall be represented by only their duly authorized in-house executives/officers and neither Party shall be represented by a Lawyer.
6. The first meeting of the IEC shall be convened by the IEC by sending appropriate communication/notice to both the parties as soon as possible but not later than 30 days from the date of his/their appointment. The hearings in the Conciliation proceeding shall ordinarily be concluded within two (2) months and, in exceptional cases where parties have expressed willingness to settle the matter or there exists possibility of settlement in the matter, the proceedings may be extended by the IEC by a maximum of further 2 months with the consent of the Parties subject to cogent reasons being recorded in writing.
7. The IEC shall thereafter formulate recommendations for settlement of the Disputes supported by reasons at the earliest

but in any case within 15 days from the date of conclusion of the last hearing. The recommendations so formulated along with the reasons shall be furnished by the IEC to both the Parties at the earliest but in any case within 1 month from the date of conclusion of the last hearing.

8. Response/modifications/suggestions of the Parties on the recommendations of the IEC are to be submitted to the IEC within time limit stipulated by the IEC but not more than 15 days from the date of receipt of the recommendations from the IEC.
9. In the event, upon consideration, further review of the recommendations is considered necessary, whether by BHEL or by the other Party, then, the matter can be remitted back to the IEC with request to reconsider the same in light of the issues projected by either/both the Parties and to submit its recommendations thereon within the following 15 days from the date of remitting of the case by either of the Parties.
10. Upon the recommendations by the Parties, with or without modifications, as considered necessary, the IEC shall be called upon to draw up the Draft Settlement Agreement in terms of the recommendations.
11. When a consensus can be arrived at between the parties only in regard to any one or some of the issues referred for Conciliation the draft Settlement Agreement shall be accordingly formulated in regard to the said Issue(s), and the said Settlement Agreement, if signed, by the parties, shall be valid only for the said issues. As regards the balance issues not settled, the parties may seek to resolve them further as per terms and conditions provided in the contract.
12. In case no settlement can be reached between the parties, the IEC shall by a written declaration, pronounce that the Conciliation between the parties has failed and is accordingly terminated.
13. Unless the Conciliation proceedings are terminated in terms of para 22 (b), (c) & (d) herein below, the IEC shall forward his/its recommendations as to possible terms of settlement within one (1) month from the date of last hearing. The date of first hearing of Conciliation shall be the starting date for calculating the period of 2 months.

14. In case of 3 members IEC, 2 members of IEC present will constitute a valid quorum for IEC and meeting can take place to proceed in the matter after seeking consent from the member who is not available. If necessary, videoconferencing may be arranged for facilitating participation of the members. However, the IEC recommendations will be signed by all members. Where there is more than one (1) Conciliator, as a general rule they shall act jointly. In the event of differences between the Members of IEC, the decision/recommendations of the majority of the Members of IEC shall prevail and be construed as the recommendation of the IEC.
15. The Draft Settlement Agreement prepared by the IEC in terms of the consensus arrived at during the Conciliation proceedings between the Parties shall be given by the IEC to both the parties for putting up for approval of their respective Competent Authority.
16. Before submitting the draft settlement agreement to BHEL's Competent Authority viz. the Board Level Committee on Alternative Dispute Resolution (BLCADR) for approval, concurrence of the other party's Competent Authority to the draft settlement agreement shall be obtained by the other party and informed to BHEL within 15 days of receipt of the final draft settlement agreement by it. Upon approval by the Competent Authority, the Settlement Agreement would thereafter be signed by the authorized representatives of both the Parties and authenticated by the members of the IEC.
17. In case the Draft Settlement Agreement is rejected by the Competent Authority of BHEL or the other Party, the Conciliation proceedings would stand terminated.
18. A Settlement Agreement shall contain a statement to the effect that each of the person(s) signing thereto (i) is fully authorized by the respective Party(ies) he/she represents, (ii) has fully understood the contents of the same and (iii) is signing on the same out of complete freewill and consent, without any pressure, undue influence.
19. The Settlement Agreement shall thereafter have the same legal status and effect as an arbitration award on agreed terms on the substance of the dispute rendered by an arbitral tribunal passed under section 30 of the Arbitration and Conciliation Act, 1996.

20. Acceptance of the Draft Settlement Agreement/recommendations of the Conciliator and/or signing of the Settlement Agreement by BHEL shall however, be subject to withdrawal/closure of any arbitral and/or judicial proceedings initiated by the concerned Party in regard to such settled issues.
21. Unless otherwise provided for in the agreement, contract or the Memorandum of Understanding, as the case may be, in the event of likelihood of prolonged absence of the Conciliator or any member of IEC, for any reason/incapacity, the Competent Authority/Head of Unit/Division/Region/Business Group of BHEL may substitute the Conciliator or such member at any stage of the proceedings. Upon appointment of the substitute Conciliator(s), such reconstituted IEC may, with the consent of the Parties, proceed with further Conciliation into the matter either de-novo or from the stage already reached by the previous IEC before the substitution.
22. The proceedings of Conciliation under this Scheme may be terminated as follows:
- On the date of signing of the Settlement agreement by the Parties; or,
  - By a written declaration of the IEC, after consultation with the parties, to the effect that further efforts at conciliation are no longer justified, on the date of the declaration; or,
  - By a written declaration of the Parties addressed to the IEC to the effect that the Conciliation proceedings are terminated, on the date of the declaration; or,
  - By a written declaration of a Party to the other Party and the IEC, if appointed, to the effect that the Conciliation proceedings are terminated, on the date of the declaration.
  - On rejection of the Draft Settlement Agreement by the Competent Authority of BHEL or the other Party.
23. The Conciliator(s) shall be entitled to following fees and facilities:

<b>Sl No</b>	<b>Particulars</b>	<b>Amount</b>
1	Sitting fees	Each Member shall be paid a Lump Sum fee of Rs 75,000/- for the whole case payable in terms of paragraph No. 27 herein below.
2	Towards drafting of settlement agreement	In cases involving claim and/or counter-claim of up to Rs 5crores. Rs 50,000/- (Sole Conciliator)

Sl No	Particulars	Amount
		<p>In cases involving claim and/or counter-claim of exceeding Rs 5 crores but less than Rs 10 crores. Rs 75,000 (per Conciliator) In cases involving claim and/or counter-claim of more than Rs 10 crores. Rs 1,00,000/- (per Conciliator)</p> <p>Note: The aforesaid fees for the drafting of the Settlement Agreement shall be paid on Signing of the Settlement Agreement after approval of the Competent Authority or Rejection of the proposed Settlement Agreement by the Competent Authority of BHEL.</p>
3	Secretarial expenses	<p>Rs 10,000/- (one time) for the whole case for Conciliation by a Sole Member IEC.</p> <p>Where Conciliation is by multi member Conciliators –Rs 30,000/- (one time)- to be paid to the IEC</p>
4	<p>Travel and transportation and stay at outstation</p> <p>i) Retired Senior Officials of other Public Sector Undertakings (pay scale wise equivalent to or more than E-8 level of BHEL)</p> <p>Others</p>	<p>As per entitlement of the equivalent officer (pay scale wise) in BHEL.</p> <p>As per the extant entitlement of whole time Functional Directors in BHEL.</p>

<b>Sl No</b>	<b>Particulars</b>	<b>Amount</b>
		Ordinarily, the IEC Member(s) would be entitled to travel by air Economy Class.
5	Venue for meeting	Unless otherwise agreed in the agreement, contract or the Memorandum of Understanding, as the case may be, the venue/seat of proceedings shall be the location of the concerned Unit / Division / Region / Business Group of BHEL. Without prejudice to the seat/venue of the Conciliation being at the location of concerned BHEL Unit / Division / Region / Business Group, the IEC after consulting the Parties may decide to hold the proceedings at any other place/venue to facilitate the proceedings. Unless, Parties agree to conduct Conciliation at BHEL premises, the venue is to be arranged by either Party alternately.

24. The parties will bear their own costs including cost of presenting their cases/evidence/witness(es)/expert(s) on their behalf. The parties agree to rely upon documentary evidence in support of their claims and not to bring any oral evidence in IEC proceedings.
25. If any witness(es) or expert(s) is/are, with the consent of the parties, called upon to appear at the instance of the IEC in connection with the matter, then, the costs towards such witness(es)/expert(s) shall be determined by the IEC with the consent of the Parties and the cost so determined shall be borne equally by the Parties.
26. The other expenditures/costs in connection with the Conciliation proceedings as well as the IEC's fees and expenses shall be shared by the Parties equally.
27. Out of the lump sum fees of Rs 75,000/- for Sitting Fees, 50% shall be payable after the first meeting of the IEC and the remaining 50% of the Sitting Fees shall be payable only after

termination of the conciliation proceedings in terms of para 22 hereinabove.

28. The travelling, transportation and stay at outstation shall be arranged by concerned Unit as per entitlements as per Serial No. 3 of the Table at para 23 above, and in case such arrangements are not made by the BHEL Unit, the same shall be reimbursed to the IEC on actuals limited to their entitlement as per Serial No. 4 of the Table at Para 23 above against supporting documents. The IEC Member(s) shall submit necessary invoice for claiming the fees/reimbursements.
29. The Parties shall keep confidential all matters relating to the conciliation proceedings. Confidentiality shall extend also to the settlement agreement, except where its disclosure is necessary for purposes of its implementation and enforcement or as required by or under a law or as per directions of a Court/Governmental authority/ regulatory body, as the case may be.
30. The Parties shall not rely upon or introduce as evidence in any further arbitral or judicial proceedings, whether or not such proceedings relate to the Disputes that is the subject of the Conciliation proceedings:
  - a. Views expressed or suggestions made by the other party in respect of a possible settlement of the Disputes;
  - b. admissions made by the other party in the course of the Conciliator proceedings;
  - c. proposals made by the Conciliator;
  - d. The fact that the other Party had indicated his willingness to accept a proposal for settlement made by the Conciliator.
31. The Parties shall not present the Conciliator(s) as witness in any Alternative Dispute Resolution or Judicial proceedings in respect of a Disputes that is/was the subject of that particular Conciliation proceeding.
32. None of the Conciliators shall act as an arbitrator or as a representative or counsel of a Party in any arbitral or judicial proceeding in respect of a Disputes that is/was the subject of that particular Conciliation proceeding.
33. The Parties shall not initiate, during the Conciliation proceedings, any arbitral or judicial proceedings in respect of a Disputes that is the subject matter of the Conciliation

proceedings except that a Party may initiate arbitral or judicial proceedings where, in his opinion, such proceedings are necessary for preserving his rights including for preventing expiry of period of limitation. Unless terminated as per the provisions of this Scheme, the Conciliation proceedings shall continue notwithstanding the commencement of the arbitral or judicial proceedings and the arbitral or judicial proceedings shall be primarily for the purpose of preserving rights including preventing expiry of period of limitation.

34. The official language of Conciliation proceedings under this Scheme shall be English unless the Parties agree to some other language.

**FORMAT FOR SEEKING CONSENT FOR REFERRING THE DISPUTES  
TO CONCILIATION THROUGH IEC**

To,

M/s. (Stakeholder's name)

**Sub: Resolution of the Disputes through conciliation by Independent  
Expert Committee (IEC).**

Ref: Contract No/MoU/Agreement/LOI/LOA& date \_\_\_\_\_.

Sir,

With reference to above referred Contract/MoU/Agreement/LOI/LOA, you have raised certain Disputes/claims. Vide your letter dated\_\_\_\_ you have requested BHEL to refer the Disputes/claims to IEC for Conciliation.

We are enclosing herewith Format (3) for giving consent and the terms and conditions of BHEL Conciliation Scheme, 2018 governing conciliation through IEC. You are requested to give your unconditional consent to the said terms and conditions of the Scheme by returning the same duly sealed and signed on each page. On receipt of your consent, matter will be put to the Competent Authority for consideration and decision.

Please note that BHEL has also certain claims against you (if applicable). BHEL reserves its right to agree or not to agree conciliation of the said disputes through BHEL and this letter is being issued without prejudice to BHEL's rights and contentions available under the contract and law.

Yours faithfully,

**Representative of BHEL**

**FORMAT FOR GIVING CONSENT BY  
CONTRACTOR/VENDOR/CUSTOMER/COLLABORATOR/CONSORTI  
UM PARTNERS FOR REFERRING THE DISPUTES TO CONCILIATION  
THROUGH IEC**

To,

BHEL

.....

**Sub: Resolution of Disputes through Conciliation by Independent  
Expert Committee (IEC).**

Ref: Contract/MoU/Agreement/LOI/LOA No      & date\_\_\_\_

With reference to above referred contract, our following bills/invoices/claims submitted to BHEL are still unpaid giving rise to Disputes:

SL. no.	Claim Description	Bill submitted to BHEL (no. and date)	Amount of the bill/claim	Amount received from BHEL	Outstanding Amount

Accordingly we request you to kindly refer the Disputes in respect of above claims to IEC for Conciliation.

We hereby agree and give our unconditional consent to the terms and conditions of BHEL Conciliation Scheme, 2018 governing conciliation through IEC. We have signed the same on each page and enclosed it for your consideration.

Yours faithfully,

**(Signature with stamp)**

**Authorized Representative of Contractor  
Name, with designation  
Date**

**STATEMENT OF CLAIMS/COUNTER CLAIMS TO BE SUBMITTED TO  
THE IEC BY BOTH THE PARTIES**

1. Chronology of the Disputes
2. Brief of the Contract/MoU/Agreement/LOI/LOA
3. Brief history of the Disputes:
4. Issues:
5. Details of Claim(s)/Counter Claim(s):

<b>SI. No.</b>	<b>Description of claim(s)/Counter Claim</b>	<b>Amount (in INR)Or currency applicable in the contract</b>	<b>Relevant contract clause</b>

6. Basis/Ground of claim(s)/counter claim(s) (along with relevant clause of contract)

**Note**– *The Statement of Claims/Counter Claims may ideally be restricted to maximum limit of 20 pages. Relevant documents may be compiled and submitted along with the statement of Claims/Counter Claims. The statement of Claims/Counter Claims is to be submitted to all IEC members and to the other party by post as well as by email.*

## BANK GUARANTEE FOR PERFORMANCE SECURITY

(Non-Judicial Stamp paper/e-stamp paper of appropriate value as per Stamp Act prevailing in the State(s))

Bank Guarantee No:

Date:

To

NAME

& ADDRESSES OF THE BENEFICIARY

**IFSC AND MICR CODE**

Dear Sirs,

1. In consideration of Bharat Heavy Electricals Limited (hereinafter referred to as the 'Employer' which expression shall unless repugnant to the context or meaning thereof, include its successors and permitted assigns) incorporated under the Companies Act, 1956 and having its registered office at \_\_\_\_\_<sup>1</sup> through its Unit at.....(name of the Unit) having awarded to ( Name of the Vendor / Contractor / Supplier ) (VENDOR CODE ) with its registered office at \_\_\_\_\_<sup>2</sup> hereinafter referred to as the 'Vendor / Contractor / Supplier ', which expression shall unless repugnant to the context or meaning thereof, include its successors and permitted assigns), a contract Ref No.....dated .....<sup>3</sup> valued at Rs.....<sup>4</sup> ( Rupees -----)/FC.....(in words.....) for .....<sup>5</sup> (hereinafter called the 'Contract') and the Vendor / Contractor / Supplier having agreed to provide a Contract Performance Bank Guarantee, equivalent to .....% (... Percent) of the said value of the Contract to the Employer for the faithful performance of the Contract,

2. we, ....., (hereinafter referred to as the Bank), having registered/Head office at ..... and inter alia a branch at ..... being the Guarantor under this Guarantee, hereby, irrevocably and unconditionally undertake to forthwith and immediately pay to the Employer any sum or sums upto a maximum amount of Rs -----<sup>6</sup> ( Rupees -----) without any demur, immediately on first demand from the Employer and without any reservation, protest, and recourse and without the Employer needing to prove or demonstrate reasons for its such demand.

3. Any such demand made on the Bank shall be conclusive as regards the amount due and payable by the Bank under this guarantee. However, our liability under this guarantee shall be restricted to an amount not exceeding Rs. \_\_\_\_\_.

4. We undertake to pay to the Employer any money so demanded notwithstanding any dispute or disputes raised by the Vendor / Contractor / Supplier in any suit or proceeding pending before any Court or Tribunal, Arbitrator or any other authority, our liability under this present being absolute and unequivocal.

5. The payment so made by us under this Guarantee shall be a valid discharge of our liability for payment thereunder and the Vendor / Contractor / Supplier shall have no claim against us for making such payment.

6. We the .....bank further agree that the guarantee herein contained shall remain in full force and effect during the period that would be taken for the performance of the said Contract/satisfactory completion of the performance guarantee period as per the terms of the Contract and that it shall continue to be enforceable till all the dues of the Employer under or by virtue of the said Contract have been fully paid and its claims satisfied or discharged.

7. We.....BANK further agree with the Employer that the Employer shall have the fullest liberty without our consent and without affecting in any manner our obligations hereunder to vary any of the terms and conditions of the said Contract or to extend time of performance by the said Vendor / Contractor / Supplier from time to time or to postpone for any time or from time to time any of the powers exercisable by the Employer against the said Vendor / Contractor / Supplier and to forbear or enforce any of the terms and conditions relating to the said Contract and we shall not be relieved from our liability by reason of any such variation, or extension being granted to the said Vendor / Contractor / Supplier or for any forbearance, act or omission on the part of the Employer or any indulgence by the Employer to the said Vendor / Contractor / Supplier or by any such matter or thing whatsoever which under the law relating to sureties would but for this provision have effect of so relieving us.

8. The Bank also agrees that the Employer at its option shall be entitled to enforce this Guarantee against the Bank as a principal debtor, in the first instance without proceeding against the Vendor / Contractor / Supplier and notwithstanding any security or other guarantee that the Employer may have in relation to the Vendor / Contractor / Supplier's liabilities.

9. This Guarantee shall remain in force upto and including.....<sup>7</sup> and shall be extended from time to time for such period as may be desired by Employer.

10. This Guarantee shall not be determined or affected by liquidation or winding up, dissolution or change of constitution or insolvency of the Vendor / Contractor / Supplier but shall in all respects and for all purposes be binding and operative until payment of all money payable to the Employer in terms thereof.

11. Unless a demand or claim under this guarantee is made on us in writing on or before the .....<sup>8</sup>we shall be discharged from all liabilities under this guarantee thereafter.

12. Any claim or dispute arising under the terms of this document shall only be enforced or settled in the Courts at Tiruchirappalli.

13. We..... BANK lastly undertake not to revoke this guarantee during its currency except with the previous consent of the Employer in writing.

Notwithstanding anything to the contrary contained hereinabove:

- a) The liability of the Bank under this Guarantee shall not exceed.....<sup>6</sup>

- b) This Guarantee shall be valid up to .....<sup>7</sup>
- c) Unless the Bank is served a written claim or demand on or before (minimum 3 to 6 months from the expiry date <sup>8</sup> all rights under this guarantee shall be forfeited and the Bank shall be relieved and discharged from all liabilities under this guarantee irrespective of whether or not the original bank guarantee is returned to the Bank.

14. We, \_\_\_\_\_ Bank, have power to issue this Guarantee under law and the undersigned as a duly authorized person has full powers to sign this Guarantee on behalf of the Bank.

For and on behalf of  
(Name of the Bank)

Dated.....

Place of Issue.....

BANK EMAIL ID:

BANK PHONE NO:

AUTHORISED SIGNATORIES CELL PHONE NO:

BANK FAX NO:

<sup>1</sup> NAME AND ADDRESS OF EMPLOYER I.e Bharat Heavy Electricals Limited

<sup>2</sup> NAME AND ADDRESS OF THE VENDOR /CONTRACTOR / SUPPLIER.

<sup>3</sup> DETAILS ABOUT THE NOTICE OF AWARD/CONTRACT REFERENCE

<sup>4</sup> CONTRACT VALUE

<sup>5</sup> PROJECT/SUPPLY DETAILS

<sup>6</sup> BG AMOUNT IN FIGURES AND WORDS

<sup>7</sup> VALIDITY DATE

<sup>8</sup> DATE OF EXPIRY OF CLAIM PERIOD

<b>List of Consortium Banks</b>	
<b>Sl. No.</b>	<b>Name of the bank</b>
1.	State Bank of India
2.	Canara Bank
3.	Axis Bank
4.	Bank of Baroda
5.	Central bank
6.	Citi Bank N.A.
7.	Deutsche Bank
8.	Exim Bank
9.	Federal Bank Limited
10.	HDFC Bank Limited
11.	Hongkong and Shanghai Banking Corporation Limited
12.	Indian Bank
13.	ICICI Bank Limited
14.	IDBI Bank Limited
15.	IndusInd Bank Limited
16.	Indian Overseas Bank
17.	Kotak Mahindra Bank Limited
18.	Punjab National Bank
19.	RBL Bank Ltd.
20.	Standard Chartered Bank
21.	Union Bank of India
22.	Yes Bank Limited

## Integrity Pact (IP)

(a) IP is a tool to ensure that activities and transactions between the Company and its Bidders / Contractors are handled in a fair, transparent and corruption free manner. Following Independent External Monitors (IEMs) on the present panel have been appointed by BHEL with the approval of CVC to oversee implementation of IP in BHEL.

SL	IEM	Email
1.	Shri Otem Dai, IAS (Retd.)	iem1@bhel.in
2.	Shri Bishwamitra Pandey, IRAS (Retd.)	iem2@bhel.in
3.	Shri Mukesh Mittal, IRS (Retd.)	Iem3@bhel.in

(b) The IP as enclosed with the tender is to be submitted (duly signed by authorized signatory) along with techno-commercial bid (Part-I, in case of two/three part bid). Only those bidders who have entered into such an IP with BHEL would be competent to participate in the bidding. In other words, entering into this Pact would be a preliminary qualification.

(c) Please refer Section-8 of IP for Role and Responsibilities of IEMs. In case of any complaint arising out of the tendering process, the matter may be referred to any of the above IEM(s). All correspondence with the IEMs shall be done through email only.

### Note:

*No routine correspondence shall be addressed to the IEM (phone/post/ email) regarding the clarifications, time extensions or any other administrative queries, etc. on the tender issued. All such clarification/ issues shall be addressed directly to the tender issuing (procurement) departments officials whose contact details are provided below.*

Details of contact person(s): -

(1)

Name: Rajesh Kummar SB

Deptt: MM/BOI

Address: 24 Building, BHEL, Trichy

Phone: 0431-2574166

Email: sbrajesh@bhel.in

(2)

Name: Jiby MJ

Deptt: MM/BOI

Address: 24 Building, BHEL, Trichy

Phone: 0431-2574363

Email: mjjiby@bhel.in

**INTEGRITY PACT****Between**

Bharat Heavy Electricals Ltd. (BHEL), a company registered under the Companies Act 1956 and having its registered office at "BHEL House", Siri Fort, New Delhi - 110049 (India) hereinafter referred to as "The Principal", which expression unless repugnant to the context or meaning hereof shall include its successors or assigns of the ONE PART

**and**

\_\_\_\_\_, (description of the party along with address), hereinafter referred to as "The Bidder/ Contractor" which expression unless repugnant to the context or meaning hereof shall include its successors or assigns of the OTHER PART

**Preamble**

The Principal intends to award, under laid-down organizational procedures, contract/s for \_\_\_\_\_

**Supply of Silver Gaskets for 700MWe SG**

\_\_\_\_\_ (hereinafter referred to as "Contract"). The Principal values full compliance with all relevant laws of the land, rules and regulations, and the principles of economic use of resources, and of fairness and transparency in its relations with its Bidder(s)/ Contractor(s).

In order to achieve these goals, the Principal will appoint panel of Independent External Monitor(s) (IEMs), who will monitor the tender process and the execution of the contract for compliance with the principles mentioned above.

**Section 1- Commitments of the Principal**

- 1.1 The Principal commits itself to take all measures necessary to prevent corruption and to observe the following principles: -
  - 1.1.1 No employee of the Principal, personally or through family members, will in connection with the tender for, or the execution of a contract, demand, take a promise for or accept, for self or third person, any material or immaterial benefit which the person is not legally entitled to.
  - 1.1.2 The Principal will, during the tender process treat all Bidder(s) with equity and reason. The Principal will in particular, before and during the tender process, provide to all Bidder(s) the same information and will not provide to any Bidder(s) confidential/ additional information through which the Bidder(s) could obtain an advantage in relation to the tender process or the contract execution.
  - 1.1.3 The Principal will exclude from the process all known prejudiced persons.
- 1.2 If the Principal obtains information on the conduct of any of its employees which is a penal offence under the Indian Penal Code 1860 and Prevention of Corruption Act 1988 or any other statutory penal enactment, or if there be a substantive suspicion in this regard, the Principal will inform its Vigilance Office and in addition can initiate disciplinary actions.

**Section 2 - Commitments of the Bidder(s)/ Contractor(s)**

- 2.1 The Bidder(s)/ Contractor(s) commit himself to take all measures necessary to prevent corruption. The Bidder(s)/ Contractor(s) commits himself to observe the following principles during participation in the tender process and during the contract execution.

- 2.1.1 The Bidder(s)/ Contractor(s) will not, directly or through any other person or firm, offer, promise or give to the Principal or to any of the Principal's employees involved in the tender process or the execution of the contract or to any third person any material, immaterial or any other benefit which he/ she is not legally entitled to, in order to obtain in exchange any advantage of any kind whatsoever during the tender process or during the execution of the contract.
- 2.1.2 The Bidder(s)/ Contractor(s) will not enter with other Bidder(s) into any illegal or undisclosed agreement or understanding, whether formal or informal. This applies in particular to prices, specifications, certifications, subsidiary contracts, submission or non-submission of bids or any other actions to restrict competitiveness or to introduce cartelization in the bidding process.
- 2.1.3 The Bidder(s)/ Contractor(s) will not commit any penal offence under the relevant Indian Penal Code (IPC) and Prevention of Corruption Act; further the Bidder(s)/ Contractor(s) will not use improperly, for purposes of competition or personal gain, or pass on to others, any information or document provided by the Principal as part of the business relationship, regarding plans, technical proposals and business details, including information contained or transmitted electronically.
- 2.1.4 Foreign Bidder(s)/ Contractor(s) shall disclose the name and address of agents and representatives in India and Indian Bidder(s)/ Contractor(s) to disclose their foreign principals or associates. The Bidder(s)/ Contractor(s) will, when presenting his bid, disclose any and all payments he has made, and is committed to or intends to make to agents, brokers or any other intermediaries in connection with the award of the contract.
- 2.2 The Bidder(s)/ Contractor(s) will not instigate third persons to commit offences outlined above or be an accessory to such offences.
- 2.3 The Bidder(s)/ Contractor(s) shall not approach the Courts while representing the matters to IEMs and shall await their decision in the matter.

### **Section 3 - Disqualification from tender process and exclusion from future contracts**

If the Bidder(s)/ Contractor(s), before award or during execution has committed a transgression through a violation of Section 2 above, or acts in any other manner such as to put his reliability or credibility in question, the Principal is entitled to disqualify the Bidder(s)/ Contractor(s) from the tender process, terminate the contract, if already awarded, exclude from future business dealings and/ or take action as per the separate "Guidelines on Banning of Business dealings with Suppliers/ Contractors", framed by the Principal.

### **Section 4 - Compensation for Damages**

- 4.1 If the Principal has disqualified the Bidder (s) from the tender process before award / order acceptance according to Section 3, the Principal is entitled to demand and recover the damages equivalent to Earnest Money Deposit/ Bid Security.
- 4.2 If the Principal is entitled to terminate the Contract according to Section 3, or terminates the Contract in application of Section 3 above, the Bidder(s)/ Contractor (s) transgression through a violation of Section 2 above shall be construed breach of contract and the Principal shall be entitled to demand and recover from the Contractor an amount equal to 5% of the contract value or the amount equivalent to Security Deposit/ Performance Bank Guarantee, whichever is higher, as damages, in addition to and without prejudice to its right to demand and recover compensation for any other loss or damages specified elsewhere in the contract.

**Section 5 - Previous Transgression**

- 5.1 The Bidder declares that no previous transgressions occurred in the last 3 (three) years with any other company in any country conforming to the anti-corruption approach or with any other Public Sector Enterprise in India that could justify his exclusion from the tender process.
- 5.2 If the Bidder makes incorrect statement on this subject, he can be disqualified from the tender process or the contract, if already awarded, can be terminated for such reason or action can be taken as per the separate "Guidelines on Banning of Business dealings with Suppliers/ Contractors", framed by the Principal.

**Section 6 - Equal treatment of all Bidder (s)/ Contractor (s) / Sub-contractor (s)**

- 6.1 The Principal will enter into Integrity Pacts with identical conditions as this Integrity Pact with all Bidders and Contractors.
- 6.2 In case of Sub-contracting, the Principal Contractor shall take the responsibility of the adoption of Integrity Pact by the Sub-contractor(s) and ensure that all Sub-contractors also sign the Integrity Pact.
- 6.3 The Principal will disqualify from the tender process all Bidders who do not sign this Integrity Pact or violate its provisions.

**Section 7 - Criminal Charges against violating Bidders/ Contractors /Subcontractors**

If the Principal obtains knowledge of conduct of a Bidder, Contractor or Subcontractor, or of an employee or a representative or an associate of a Bidder, Contractor or Subcontractor which constitutes corruption, or if the Principal has substantive suspicion in this regard, the Principal will inform the Vigilance Office.

**Section 8 -Independent External Monitor(s)**

- 8.1 The Principal appoints competent and credible panel of Independent External Monitor (s) (IEMs) for this Integrity Pact. The task of the IEMs is to review independently and objectively, whether and to what extent the parties comply with the obligations under this Integrity Pact.
- 8.2 The IEMs are not subject to instructions by the representatives of the parties and performs his functions neutrally and independently. He reports to the CMD, BHEL.
- 8.3 The IEMs shall be provided access to all documents/ records pertaining to the Contract, for which a complaint or issue is raised before them as and when warranted. However, the documents/records/information having National Security implications and those documents which have been classified as Secret/Top Secret are not to be disclosed.
- 8.4 The Principal will provide to the IEMs sufficient information about all meetings among the parties related to the Contract provided such meetings could have an impact on the contractual relations between the Principal and the Contractor. The parties offer to the IEMs the option to participate in such meetings.

- 8.5 The advisory role of IEMs is envisaged as that of a friend, philosopher and guide. The advice of IEMs would not be legally binding and it is restricted to resolving issues raised by a Bidder regarding any aspect of the tender which allegedly restricts competition or bias towards some Bidders. At the same time, it must be understood that IEMs are not consultants to the Management. Their role is independent in nature and the advice once tendered would not be subject to review at the request of the organization.
- 8.6 For ensuring the desired transparency and objectivity in dealing with the complaints arising out of any tendering process or during execution of Contract, the matter should be examined by the full panel of IEMs jointly, who would look into the records, conduct an investigation, and submit their joint recommendations to the Management.
- 8.7 The IEMs would examine all complaints received by them and give their recommendations/ views to the CMD, BHEL at the earliest. They may also send their report directly to the CVO, in case of suspicion of serious irregularities requiring legal/ administrative action. Only in case of very serious issue having a specific, verifiable Vigilance angle, the matter should be reported directly to the Commission. IEMs will tender their advice on the complaints within 30 days.
- 8.8 The CMD, BHEL shall decide the compensation to be paid to the IEMs and its terms and conditions.
- 8.9 IEMs should examine the process integrity, they are not expected to concern themselves with fixing of responsibility of officers. Complaints alleging mala fide on the part of any officer of the Principal should be looked into by the CVO of the Principal.
- 8.10 If the IEMs have reported to the CMD, BHEL, a substantiated suspicion of an offence under relevant Indian Penal Code / Prevention of Corruption Act, and the CMD, BHEL has not, within reasonable time, taken visible action to proceed against such offence or reported it to the Vigilance Office, the IEMs may also transmit this information directly to the Central Vigilance Commissioner, Government of India.
- 8.11 After award of work, the IEMs shall look into any issue relating to execution of Contract, if specifically raised before them. As an illustrative example, if a Contractor who has been awarded the Contract, during the execution of Contract, raises issue of delayed payment etc. before the IEMs, the same shall be examined by the panel of IEMs. Issues like warranty/ guarantee etc. shall be outside the purview of IEMs.
- 8.12 However, the IEMs may suggest systemic improvements to the management of the Principal, if considered necessary, to bring about transparency, equity and fairness in the system of procurement.
- 8.13 The word 'Monitor' would include both singular and plural.

### **Section 9 - Pact Duration**

- 9.1 This Integrity Pact shall be operative from the date this Integrity Pact is signed by both the parties till the final completion of contract for successful Bidder, and for all other Bidders 6 months after the Contract has been awarded. Any violation of the same would entail disqualification of the bidders and exclusion from future business dealings.
- 9.2 If any claim is made/ lodged during currency of this Integrity Pact, the same shall be binding and continue to be valid despite the lapse of this Pact as specified above, unless it is discharged/ determined by the CMD, BHEL.

**Section 10 - Other Provisions**

- 10.1 This Integrity Pact is subject to Indian Laws and exclusive jurisdiction shall be of the competent Courts as indicated in the Tender or Contract, as the case may be.
- 10.2 Changes and supplements as well as termination notices need to be made in writing.
- 10.3 If the Bidder(s)/ Contractor(s) is a partnership or a consortium or a joint venture, this Integrity Pact shall be signed by all partners of the partnership or joint venture or all consortium members.
- 10.4 Should one or several provisions of this Integrity Pact turn out to be invalid, the remainder of this Integrity Pact remains valid. In this case, the parties will strive to come to an agreement to their original intentions.
- 10.5 Only those bidders / contractors who have entered into this Integrity Pact with the Principal would be competent to participate in the bidding. In other words, entering into this Integrity Pact would be a preliminary qualification.
- 10.6 In the event of any dispute between the Principal and Bidder(s)/ Contractor(s) relating to the Contract, in case, both the parties are agreeable, they may try to settle dispute through Mediation before the panel of IEMs in a time bound manner. In case, the dispute remains unresolved even after mediation by the panel of IEMs, either party may take further action as the terms & conditions of the Contract. The fees/expenses on dispute resolution through mediation shall be shared by both the parties. Further, the mediation proceedings shall be confidential in nature and the parties shall keep confidential all matters relating to the mediation proceedings including any settlement agreement arrived at between the parties as outcome of mediation. Any views expressed, suggestions, admissions or proposals etc. made by either party in the course of mediation shall not be relied upon or introduced as evidence in any further arbitral or judicial proceedings, whether or not such proceedings relate to the dispute that is the subject of mediation proceedings. Neither of the parties shall present IEMs as witness in any Alternative Dispute Resolution or judicial proceedings in respect of the dispute that was subject of mediation.

*SBRajeshk*

**S.B. RAJESH KUMMAR**  
 Senior Engineer Dy. Mgr  
 MM / Purchase / BOI  
 BHEL, TRICHY - 620 014.  
 (Office Seal)

For & On behalf of the Principal

For & On behalf of the Bidder/ Contractor  
 (Office Seal)

Place Trichy  
 Date 29.12.2022

Witness: *JIBY-M-J*  
 (Name & Address) Dy. ENGR,  
MM/BOI, BHEL TRICHY

Witness: \_\_\_\_\_  
 (Name & Address) \_\_\_\_\_

**/ On Bidder's office letter pad /**

**Self-Declaration**

<b>Enquiry No.</b>	<b>1802300011</b>
<b>Enquiry Date</b>	<b>20.02.2023</b>

In line with Government public procurement order Number P-45021/2/2017-B.E-II dated 15.06.2017, and further modified order dt. 28.05.2018 and 04.06.2020.

I / We hereby declare that I / We are a "Local Supplier" meeting the requirement of minimum local content (.....%) defined in the above government notification for the goods against above mentioned enquiry Number.

Details of location at which local value addition will be made is as follows:

Door No.	
Street / Address 1	
Street / Address 2	
District	
State	
Country	
PIN Code	

We also understand that the false declarations will be considered as breach of Integrity and liable for action.

**For Company Name:**

**Seal:**

**Signature:**

**Date:**

**Place:**

(Please fill all the yellow color field)

## PART-I (No Deviation Certificate)

Note: The following Declaration to be submitted on the bidder's Letter Head, duly signed & stamped and to be attached along with your Technical bid of the tender.

===== Supply of Silver Gaskets for 700MWe SG =====

Enquiry No.: **1802300011** dated **20.02.2023**

I/We M/s. .... have read and clearly understood all the Terms and conditions in Tender Schedule of and accordingly accept the same without any deviation what so ever.

- I/ We unconditionally agree to all the tender conditions and no new conditions are imposed by us in the technical / price bid. I understand in the event of imposing any condition in the technical / price bid, such condition would be ignored by BHEL and only the prices will be considered for the purpose of evaluation". In case of any deviation (Technical or commercial) the same is mentioned below.

SPECIFICATION	a) Technical Specification PC-M-00069/Rev.00 b) Drawings 3-93-172-05573/00 & 3-93-172-05575/00, c) Generic Quality plan for Silver foil gaskets (Annexure-C)	
DOC. REFERENCE	BHEL ENQ. CALLED FOR	FIRM'S ALTERNATE OFFER
-Nil-	-Nil-	-Nil-

- I/ We confirm that none of our group concern or affiliates etc., appears on the list of banned firms / companies by BHEL (list available on [www.bhel.com](http://www.bhel.com)) nor any of the Director / Partner / proprietor of bidder / such group concern or affiliate etc. are involved with such company.
- I/ We also declare that, we have not been suspended or black listed or issued with Show Cause Notice by BHEL- Trichy or any other BHEL Unit or any PSU/ Government organization.
- I/ We confirm that other than us, none of our group concerns or affiliates etc. are participating in the tender either directly or indirectly through any other agency under same proprietor / common director(s) / common partner(s).
- I/ We confirm that if any of the above statement / information furnished by us in this tender is found to be false/ fake at any stage of tender evaluation or during execution of contract, BHEL will have the right to initiate appropriate action including legal proceeds / termination of contract, recovery of damages, penalties etc. as deemed fit.

(Contractor Signature with Seal)

Contractor Signature

Contractor Seal

## THIRD PARTY NON-DISCLOSURE AGREEMENT

I, \_\_\_\_\_, on behalf of the \_\_\_\_\_ (Name of Company), acknowledge that the information received or generated, directly or indirectly, while working with BHEL, Trichy on contract is confidential and that the nature of the business of the BHEL, Trichy is such that the following conditions are reasonable, and therefore:

I warrant and agree as follows:

I, or any other personnel employed or engaged by our company, agree not to disclose, directly or indirectly, any information related to the BHEL, Trichy Without restricting the generality of the foregoing, it is agreed that we will not disclose such information consisting but not necessarily limited to:

- Technical information: Methods, drawings, processes, formulae, compositions, systems, techniques, inventions, computer programs/data/configuration and research projects.
- Business information: Customer lists, project schedules, pricing data, estimates, financial or marketing data,

On conclusion of contract, I, or any other personnel employed or engaged by our company shall return to BHEL, Trichy all documents and property of BHEL, Trichy, including: drawings, blueprints, reports, manuals, computer programs/data/configuration, and all other materials and all copies thereof relating in any way to BHEL, Trichy's business, or in any way obtained by me during the course of contract. I further agree that I, or any others employed or engaged by our company shall not retain copies, notes or abstracts of the foregoing.

This obligation of confidence shall continue after the conclusion of the contract also.

I acknowledge that the aforesaid restrictions are necessary and fundamental to the business of the BHEL, Trichy and are reasonable given the nature of the business carried on by the BHEL, Trichy I agree that this agreement shall be governed by and construed in accordance with the laws of country.

I enter into this agreement totally voluntarily, with full knowledge of its meaning, and without duress.

Place:- \_\_\_\_\_

Date:- \_\_\_\_\_

Name

Company

Signature