

**BHARAT HEAVY ELECTRICALS LIMITED  
TRANSMISSION BUSINESS GROUP  
SUBCONTRACTS MANAGEMENT  
PLOT NO. 25, SECTOR 16A, NOIDA,  
DISTT. – GAUTAM BUDDH NAGAR (U.P.) - 201301**



**TENDER DOCUMENTS**

**FOR**

**PRELIMINARY, DETAILED & CHECK ROUTE SURVEY AND GEOTECHNICAL  
INVESTIGATION ALONG WITH DESIGN AND ENGINEERING WORKS FOR 400kV  
TRANSMISSION LINE AT 2 X 800 MW NTPC LARA STAGE-II, CHHATTISGARH.**

**CUSTOMER**

**NTPC LIMITED**

**TENDER SPEC. NO.: TBSM/LARA/SURVEY/TENDER/24-25**

**DATE: 09.05.2024**

**TRANSMISSION BUSINESS GROUP**  
**SUBCONTRACTS MANAGEMENT**

**INDEX**

<b>Sl. No.</b>	<b>Description</b>	<b>No. of Pages</b>
1.0	Notice Inviting Tender	10
2.0	Pre-Qualifying Requirements	02
3.0	Project Information/ BHEL's Contacts	01
4.0	Health, Safety & Environment specification (Doc. No.: - TBG/HSE/NIT-01, Rev-01 Date 22.10.2021)	19
5.0	Terms & Conditions of Contract	34
6.0	Annexure A of Clause No 27 of Terms & conditions of contract BHEL-Conciliation Scheme	11
7.0	Bill of Quantity Cum price schedule	01
8.0	Price Bid Format: - To be filled by the Bidder Online through <a href="https://eprocurebhel.co.in">https://eprocurebhel.co.in</a>	01
9.0	Technical Specification (Document No- TB-423-607-000-TL-PKG-I Rev 01)	93
10.0	No Deviation Certificate	01
11.0	Declaration for relation in BHEL	01
12.0	Declaration by Bidder	01
13.0	E payment Format	01



# BHARAT HEAVY ELECTRICALS LIMITED

TRANSMISSION BUSINESS GROUP

SECTOR-16A, NOIDA -201301

e-mail: [dipak.mandal@bhel.in](mailto:dipak.mandal@bhel.in);

## NOTICE INVITING TENDER

REF.: TBSM/LARA/SURVEY/TENDER/24-25

DATE: 09.05.2024

SUB: Tender for "Preliminary, Detailed & Check Route Survey and Geotechnical Investigation along with Design and Engineering Works for 400kV Transmission Line at 2X800 MW NTPC LARA STAGE-II, Chhattisgarh".

Dear Sirs,

1. Sealed tenders are invited for the following:

NAME OF WORK	TIME OF COMPLETION	EARNEST MONEY DEPOSIT	TENDER SUBMISSION DATE AND TIME	TENDER OPENING DATE & TIME
Preliminary, Detailed & Check Route Survey and Geotechnical Investigation along with Design and Engineering Works for 400kV Transmission Line at 2X800 MW NTPC LARA STAGE-II, Chhattisgarh	Three (03) Months from the date of LOI except check survey#	Nil	20.05.2024 14.30 hrs.	20.05.2024 15.30 hrs. (Technical bid only)

# The check survey shall be done along with civil construction agency after finalizing coordination with of civil construction agency by BHEL and intimation by site in-charge. Check survey should be completed within 2 weeks including submission of check survey report.

2. Bidder has to submit offer directly through E-PROCUREMENT MODE. Bidder may visit <https://eprocurebhel.co.in>

**Procedure for Submission of Tenders through e-tendering:** The tender is also floated online through our E-Procurement Site <https://eprocurebhel.co.in> . The bidder may respond by submitting their offer online in our e-Procurement platform at <https://eprocurebhel.co.in>

Offers are invited in two-parts only.

### Documents Comprising the e-Tender

The tender shall be submitted online as mentioned below:

#### **a) Technical Bid (Un priced Tender)**

All Technical details (e.g. Eligibility Criteria requested (as mentioned below)) should be attached in e-tendering module, failing which the tender stands invalid & may be REJECTED. Bidders shall furnish the following information along with technical tender (preferably in pdf format):

i) Technical Bid (without indicating any prices).

#### **b) Price Bid:**

i) Prices are to be quoted in the attached Price Bid format online on e-tender portal.

- ii) The price should be quoted for the accounting unit indicated in the e-tender document.
  - iii) It is the responsibility of tenderer to go through the Tender document to ensure furnishing all required documents in addition to above, if any. Any deviation would result in REJECTION of tender and would not be considered at a later stage at any cost by BHEL.
  - iv) A person signing (manually or digitally) the tender form or any documents forming part of the contract on behalf of another shall be deemed to warrantee that he has authority to bind such other persons and if, on enquiry, it appears that the persons so signing had no authority to do so, the purchaser may, without prejudice to other civil and criminal remedies, cancel the contract and hold the signatory liable for all cost and damages.
  - v) A tender, which does not fulfil any of the above requirements and/or gives evasive information/reply against any such requirement, shall be liable to be ignored and rejected.
- c) Uploading of the price bid in prequalification bid or technical bid may RESULT IN REJECTION of the tender.
- d) Tenders shall be uploaded with all relevant PDF/zip format. The relevant tender documents should be uploaded by an authorized person having Class 3- SHA2- 2048 BIT-SIGNING & ENCRYPTION digital signature certificate (DSC).
3. **Bidders may please note that no other mode of bid submission shall be considered for evaluation apart from Clause no. 02 mentioned above.**
4. The prospective bidders who have downloaded the tender documents from our website are requested to send their acknowledgement and willingness to participate in the tender to the undersigned, through email.
5. Offers should be strictly in accordance with the Tender Specifications and General Instructions to Tenderer enclosed herewith.
6. "BHEL shall be resorting to Reverse Auction (RA) (Guidelines as available on [www.bhel.com](http://www.bhel.com)) for this tender. RA shall be conducted among all the techno-commercially qualified bidders.
- Price bids of all techno-commercially qualified bidders shall be opened and same shall be considered for RA. In case any bidder(s) do(es) not participate in online Reverse Auction, their price bid along with applicable loading, if any, shall be considered for ranking."
7. The contractor shall give his explicit confirmation without any deviations to the HSE (Health, Safety and Environment) requirements as per enclosed specification No. TBG/HSE/NIT-01, Rev-02, Date 31.01.24. Contactors are also required to furnish details as per Annexure (HSE) to NIT along with their offer. Offers received without compliance & data about HSE requirements are liable to be rejected.
8. All documents submitted with the offer shall be signed and stamped in each page by authorized representative of the bidder.
9. Clarifications, if any, can be obtained from the undersigned but such requests should be submitted well before the due date for submission of tenders. Due date for submission and opening of tenders will not be extended on such grounds.
10. Drawings & FQP enclosed with the NIT (if provided) are for tender purpose only. Drawings & FQP may get change during execution stage and work to be carried as per latest RFC drawings & Field Quality Plan (FQP).

11. Construction/ RFC drawing/ Fronts shall be furnished progressively as per project requirement and no claim towards idling charges/ project overheads etc. borne by the contractor on account of non-availability of drawings/ fronts shall be entertained.
12. **Completion period of the work has been envisaged under best possible conditions. Any changes/ deviation during execution shall be dealt as per relevant clauses mentioned in Terms & Conditions of contract.**
13. The offers of the bidders who are under suspension as also the offers of the bidders, who engage the services of the banned firms, shall be rejected. The list of banned firms is available on BHEL web site [www.bhel.com](http://www.bhel.com).
14. The Bidders are advised to visit Site to have better understanding of job.
15. Integrity commitment, performance of the contract and punitive action thereof:
  - 12.1. Commitment by BHEL:

BHEL commits to take all measures necessary to prevent corruption in connection with the tender process and execution of the contract. BHEL will during the tender process treat all Bidder(s) in a transparent and fair manner, and with equity.
  - 12.2. Commitment by Bidder/ Supplier/ Contractor:
    - 12.2.1. The bidder/ supplier/ contractor commits to take all measures to prevent corruption and will not directly or indirectly influence any decision or benefit which he is not legally entitled to nor will act or omit in any manner which tantamount to an offence punishable under any provision of the Indian Penal Code, 1860 or any other law in force in India.
    - 12.2.2. The bidder/ supplier/ contractor will, when presenting his bid, disclose any and all payments he has made, and is committed to or intends to make to agents, brokers or any other intermediaries in connection with the award of the contract and shall adhere to relevant guidelines issued from time to time by Govt. of India/ BHEL.
    - 12.2.3. The bidder/ supplier/ contractor will perform/ execute the contract as per the contract terms & conditions and will not default without any reasonable cause, which causes loss of business/ money/ reputation, to BHEL.

If any bidder/ supplier/ contractor during pre-tendering/ tendering/ post tendering/ award/ execution/ post-execution stage indulges in mal-practices, cheating, bribery, fraud or and other misconduct or formation of cartel so as to influence the bidding process or influence the price or acts or omits in any manner which tantamount to an offence punishable under any provision of the Indian Penal Code, 1860 or any other law in force in India, then, action may be taken against such bidder/ supplier/ contractor as per extant guidelines of the company available on [www. bhel.com](http://www.bhel.com) and/or under applicable legal provisions”.
16. Also, offer of the bidders who are suspended (under hold/ delist) for business dealings by BHEL, TBG shall not be considered. Please note that lifting/ restoration of suspension (Ban/Hold/ De-list) of business dealing is not automatic after expiry of specified suspension period. Hence, vendor shall be considered as suspended for business till suspension is lifted by BHEL in writing on specific request of the vendor as per extant guidelines.

17. BHEL Fraud Prevention Policy, "The Bidder along with its associate/ collaborators/ sub-contractors/ sub-vendors/ consultants/ service providers shall strictly adhere to BHEL Fraud Prevention Policy displayed on BHEL website <http://www.bhel.com> and shall immediately bring to the notice of BHEL Management about any fraud or suspected fraud as soon as it comes to their notice."
18. Offers will be scrutinized based on the qualifying requirements and only those who are technically and financially capable to execute the Job and who fulfil the Pre-Qualifying Requirements (PQR) are eligible to quote against the above NIT. However, final acceptance of the bidder/ offer shall be subject to acceptance of our customer.
19. **The evaluation currency for this tender shall be INR.**
20. In the course of evaluation, if more than one bidder happens to occupy L-1 status, effective L-1 will be decided by soliciting discounts from the respective L-1 bidders.

In case more than one bidder happens to occupy the L-1 status even after soliciting discounts, the L-1 bidder shall be decided by toss/ draw of lots, in the presence of the respective L-1 bidder(s) or their representative(s).

Ranking will be done accordingly. BHEL's decision in such situations shall be final and binding.

21. Technical Bid will be opened in the office of undersigned. The price bids will be opened subsequently, after Technical Bids of all the bidders have been evaluated and frozen. Bidders should quote their most competitive rates as there will not be any price negotiation. However, if felt necessary by BHEL, price negotiation will be held with lowest bidder (L-1) only. **IT WOULD BE PREFERRED THAT YOUR OFFER IS WITHOUT ANY DEVIATION w.r.t. TENDER SPECIFICATIONS.** Offers with deviations are likely to be rejected.
22. In case any adverse information is received concerning performance, capability or conduct of the bidder after issue of tender enquiry, BHEL reserves the right to reject the offer at any stage as deemed fit.
23. Any materials (if required) for civil works have to be procured from Customer approved sources only. It will be the bidder's responsibility to get the approval of materials and vendors for materials.
24. The purchase preference for central P.S.U.s shall be given as per the prevailing Government policy.
25. In case an offer is not being submitted by the prospective bidders against this tender, they may send their "regret" letter to this office, for information.
26. Details of qualifying work(s) executed by the bidder will be forwarded to the principal employer for verification of the work with respect to completion, commencement & completion date and value of the work executed. Performance feedback of the bidder will also be sought from the principal employer.
27. The bidder representative may be called for discussion with the committee. His originals may be verified by the committee. In addition to above their organisation chart and detail list of manpower, tools & plants and technical capability will be discussed and ascertained by the committee.

28. Conflict of Interest among bidders/Agents: -

"A bidder shall not have conflict of interest with other bidders. Such conflict of interest can lead to anti-competitive practices to the detriment of Procuring Entity's interests. **The bidder found to have a conflict of interest shall be disqualified.** A bidder may be considered to have a conflict of interest with one or more parties in this bidding process, if:

- a) they have controlling partner (s) in common; **or**
- b) they receive or have received any direct or indirect subsidy/ financial stake from any of them; **or**
- c) they have the same legal representative/agent for purposes of this bid; **or**
- d) they have relationship with each other, directly or through common third parties, that puts them in a position to have access to information about or influence on the bid of another Bidder; or
- e) Bidder participates in more than one bid in this bidding process. Participation by a Bidder in more than one Bid will result in the disqualification of all bids in which the parties are involved. However, this does not limit the inclusion of the components/ sub-assembly/ Assemblies from one bidding manufacturer in more than one bid; or
- f) In cases of agents quoting in offshore procurements, on behalf of their principal manufacturers, one agent cannot represent two manufacturers or quote on their behalf in a particular tender enquiry. One manufacturer can also authorise only one agent/dealer. There can be only one bid from the following:
  1. The principal manufacturer directly or through one Indian agent on his behalf; and
  2. Indian/foreign agent on behalf of only one principal;

**or**
- g) A Bidder or any of its affiliates participated as a consultant in the preparation of the design or technical specifications of the contract that is the subject of the Bid; **or**
- h) In case of it holding company having more than one independently manufacturing units, or more than one unit having common business ownership/management, only one unit should quote. Similar restrictions would apply to closely related sister companies. Bidders must proactively declare such sister/ common business/ management units in same/ similar line of business. "

Thanking you,

Yours faithfully,  
For and on behalf of BHEL,

**(Dipak Kumar Mandal)**  
**AGM /TBSM**

**TO BE FILLED BY TENDERER OVER THEIR LETTERHEAD**

**ANNEXURE - X**

**REF.: TBSM/LARA/SURVEY/TENDER/24-25**

**DATE: 09.05.2024**

**SUB: TENDER FOR “Preliminary, Detailed & Check Route Survey and Geotechnical Investigation along with Design and Engineering Works for 400kV Transmission Line at 2X800 MW NTPC LARA STAGE-II, Chhattisgarh”.**

It is certified that General Instructions and Information for tenderer have been read/ complied/ agreed to and each page of tender offer has been initialled and stamped.

Also It is being declares that we ( .....Bidder Name .....) will not enter into any illegal or undisclosed agreement or understanding, whether formal or informal with other Bidder(s). This applies in particular to prices, specifications, certifications, subsidiary contracts, submission or non-submission of bids or any other actions to restrict competitiveness or to introduce cartelization in the bidding process.

In case, the Bidder is found having indulged in above activities, suitable action shall be taken by BHEL as per extant policies/ guidelines

(Signature of Tenderer)

Name and Designation of Authorised person (s)  
Signing the tender on behalf of the tenderer

**(TO BE FILLED BY TENDERER OVER THEIR LETTERHEAD)**

---

**ANNEXURE - Y**

REF.: TBSM/LARA/SURVEY/TENDER/24-25

DATE: 09.05.2024

**SUB: TENDER FOR "Preliminary, Detailed & Check Route Survey and Geotechnical Investigation along with Design and Engineering Works for 400kV Transmission Line at 2X800 MW NTPC LARA STAGE-II, Chhattisgarh".**

**Subject: Declaration confirming knowledge about Site conditions**

I/We, \_\_\_\_\_ hereby declare and confirm that we have visited the Project Site with reference to above BHEL Tender Specifications and acquired full knowledge and information about the Site conditions including Wage structure, Industrial Climate, the Law & Order and other conditions prevalent at and around the Site. Also, we have acquired information about availability of manpower, construction material, water, electricity etc.

We further confirm that the above information is true and correct and we shall not raise any claim of any nature due to lack of knowledge of Site conditions.

I/We, hereby offer to carry out work as detailed in above mentioned Tender Specification, in accordance with Terms & Conditions thereof.

(Signature of Tenderer)

Name and Designation of Authorised person (s)  
Signing the tender on behalf of the tenderer

**Authorization of representative who will participate in the Online Reverse Auction Process:**

1	NAME & DESIGNATION OF OFFICIAL	
2	POSTAL ADDRESS (COMPLETE)	
3	TELEPHONE NOS. (LAND LINE & MOBILE BOTH)	
4	FAX NO.	
5	E-MAIL ADDRESS	
6	NAME OF PLACE / STATE / COUNTRY, WHEREFROM S/HE WILL PARTICIPATE IN THE REVERSE AUCTION	

**BHARAT HEAVY ELECTRICALS LIMITED**  
**TRANSMISSION BUSINESS GROUP, NOIDA**  
**PRE-QUALIFYING REQUIREMENTS**

Tender Ref. No.: TBSM/LARA/SURVEY/TENDER/24-25

DATE: 09.05.2024

Subject: Pre-Qualifying Requirements

Sl. No.	Criteria	Description
A.	Turn Over	<p>Bidder should have a minimum average annual turnover*of ₹ 7,65,000/- for last three financial years (2020-21, 2021-22 &amp; 2022-23 or 2021-22, 2022-23 &amp; 2023-24) and should submit audited balance sheet and Profit &amp; Loss Account Sheet of these years.</p> <p>In case audited financial statements have not been submitted for all the three years as indicated above, then the applicable audited statements submitted by the bidders against the requisite three years, will be averaged for three years i.e. total divided by three.</p> <p>The audited financial statements must be signed by the owner and the auditor. Auditors seal, Name, Membership No., Firm Registration No. &amp; firm name (if applicable), UDIN and the capacity in which he is signing (Proprietor/Partner), must be mentioned on the Profit &amp; Loss A/c and Balance Sheet.</p> <p>In case audited balance sheet is not available due to turnover being less than statutory requirement of audit, bidder should furnish self-certified copies of Balance Sheet, Profit &amp; Loss account along with income tax returns and form 26AS of these years.</p> <p>*Annual Gross Revenue from operations/ Gross operating income as incorporated in the profit &amp; loss account excluding Other Income.</p>
B.	Profit	<p>Vendor should have earned profit in at least one year during last three financial years as mentioned in A above.</p>
C.	Similar Work	<p>The bidder should have successfully completed “<b>Survey, Design &amp; Engineering Work for 220kV of higher Transmission Line</b>” during last seven years ending on <b>31.03.2024</b> and should be either of the following:</p> <p><b>Three similar jobs executed costing (except service tax/GST) not less than ₹ 10,20,000/-each.</b></p> <p style="text-align: center;">OR</p> <p><b>Two similar jobs executed costing (except service tax/GST) not less than ₹ 12,75,000/- each.</b></p> <p style="text-align: center;">OR</p> <p><b>One similar job executed costing (except service tax/GST) not less than ₹ 20,40,000/-.</b></p>

Notes (General points):

1. The word 'executed' means the bidder should have achieved the criteria specified in the PQR even if the total contract has not been completed or closed.
2. The bidder shall submit the Contract Agreement/ Work Order/LOI/Any Proof of completion of work issued by Customer/Contractor in support of experience along with technical bid.
3. In order to technically qualify, bidder should meet all the criteria i.e. A, B & C mentioned above.
4. If the qualifying work is executed in the last seven years period, as specified above, even if it has been started earlier, the same will also be considered meeting the qualifying requirements.
5. Consortium/JV bidding is not allowed.
6. Bidder shall quote prices in INR only for all the items of BOQ.
7. BHEL reserves the right to:
  - a. Accept or reject any bid received at its discretion without assigning any reasons whatsoever.
  - b. Postpone the above-mentioned date, split and distribute the work among more than one bidder without assigning any reason whatsoever.
  - c. May ask for further qualification during techno commercial scrutiny of bids received.
  - d. May ask for further proofs including **Form 26AS** /TDS certificates/ Final bill/ payment detail for the said job for cross- verification
8. BHEL shall not be liable for any expenses incurred by bidder in preparation of bid irrespective of whether it is accepted or not.
9. Quotations received from bidders who do not fulfil the PQR shall be summarily rejected without any further evaluation and information to bidders.
10. Canvassing i.e. soliciting favour, seeking advantage etc. in any form is strictly prohibited and any bidder found to have engaged in canvassing shall be liable to have his bid rejected summarily.
11. If the bidder deliberately gives any wrong information in his tender to create in circumstances for the acceptance to his bid, BHEL reserves the right to reject such application.
12. Bidder's selection is subject to approval of BHEL's customer for this work.
13. All corrigenda, addenda, amendments and clarifications to this Tender will be hosted in web page, [www.bhel.com](http://www.bhel.com) & <https://eprocurebhel.co.in> and not in the newspaper. Bidders shall keep themselves updated with all such amendments.

# **PROJECT INFORMATION**

## **1.0 CUSTOMER:**

NTPC Limited

## **2.0 PROJECT LOCATION AND DETAILS:**

**PRELIMINARY, DETAILED & CHECK ROUTE SURVEY AND GEOTECHNICAL INVESTIGATION ALONG WITH DESIGN AND ENGINEERING WORKS FOR 400KV TRANSMISSION LINE AT 2 X 800 MW NTPC LARA STAGE-II, CHHATTISGARH.**

Site Address & Location: -

NTPC Limited  
Lara Super Thermal Power Project  
Stage-II (2x800 MW)  
P.O. – Pussore, Village – Chhapora,  
Raigarh, Chhattisgarh-496440  
(The project site is approachable from NH-200  
(Raigarh/Sarangarh) via Kondatarai through State PWD  
Road.)

## **3.0 CONTACT PERSON: FOR CONTRACTUAL ISSUES**

DIPAK KUMAR MANDAL  
AGM (TBSM)  
SUBCONTRACTS MANAGEMENT,  
TRANSMISSION BUSINESS GROUP,  
Plot No. 25, Sector-16A, Noida,  
Distt. Gautambudh Nagar, UP-201301  
PHONE: 0120-674-8134/ 99111 63182  
E-mail: [dipak.mandal@bhel.in](mailto:dipak.mandal@bhel.in)

## **CONTACT PERSON: FOR ENGINEERING ISSUES**

Manvender Singh Pundir  
Manager (TBEM)  
TRANSMISSION BUSINESS GROUP,  
Plot No. 25, Sector-16A, Noida,  
Distt. Gautambudh Nagar, UP-201301  
PHONE: 0120-674- 8512/ 9916366333  
E-mail: [manvender@bhel.in](mailto:manvender@bhel.in)

## **CONTACT PERSON: FOR CONTRACT EXECUTION ISSUES**

Rajiv Lal  
AGM & Sector Head (TBWS-Construction)  
TRANSMISSION BUSINESS GROUP,  
C-18, BHEL Township, Gayatri Nagar,  
Gotri Road, Vadodara - 390 021

PHONE: 9557494442  
E-mail: [rajivlal@bhel.in](mailto:rajivlal@bhel.in)

# HSE CONDITIONS

at a **GLANCE** (for bidders)



Health Safety and Environment Management



**BHARAT HEAVY ELECTRICALS LIMITED**  
TRANSMISSION BUSINESS GROUP

	<b>Transmission Business Group</b> <b>HSE Department, HQ, Noida</b>	<b>Doc No. TBG/HSE/NIT-01</b> <b>Rev No. : 02</b> <b>Date: 31.01.24</b>
	<b>HSE Conditions at a Glance for Bidders</b>	<b>Page- 1 of 18</b>



## Transmission Business Group, Noida

DOCUMENT CONTROL			
Document number:	TBG/HSE/NIT-01		
Issue number:	00	Issue date:	08.01.2020
Revision number:	01	Revision date :	22.10.2021
Revision number:	02	Revision date :	31.01.2024
	Prepared by	Approved and Issued for use by	
Name	Arvind Kumar Pandey	RS Pathwar	
Designation	Sr. Engineer	Dy. General Manager	
Signature	-sd-	-sd-	
Date	31.01.2024	31.01.2024	
Doc. copy issue no. :		Doc. copy issue date :	
Issued to :	Name	Designation	Signature
Issued by :	Name	Designation	Signature

## BHARAT HEAVY ELECTRICALS LIMITED

### TRANSMISSION BUSINESS GROUP



Transmission Business Group

HSE Department, HQ, Noida

Doc No. TBG/HSE/NIT-01

Rev No. : 02

Date: 31.01.24

HSE Conditions at a Glance for Bidders

Page- 2 of 18

BHEL TBG through its long experience and policy, has developed a culture to consider wellbeing of the society, protection of environment and occupational health and safety of its workers first. TBG has also a culture of transparency in all its business activities. In line to this culture, this NIT annexure is prepared as a peeping window in to the TBG HSE requirements which need to be 100% complied by the successful bidders while executing the contract. Interested bidders should go through these HSE conditions:

## 1. BHEL HSE Policy

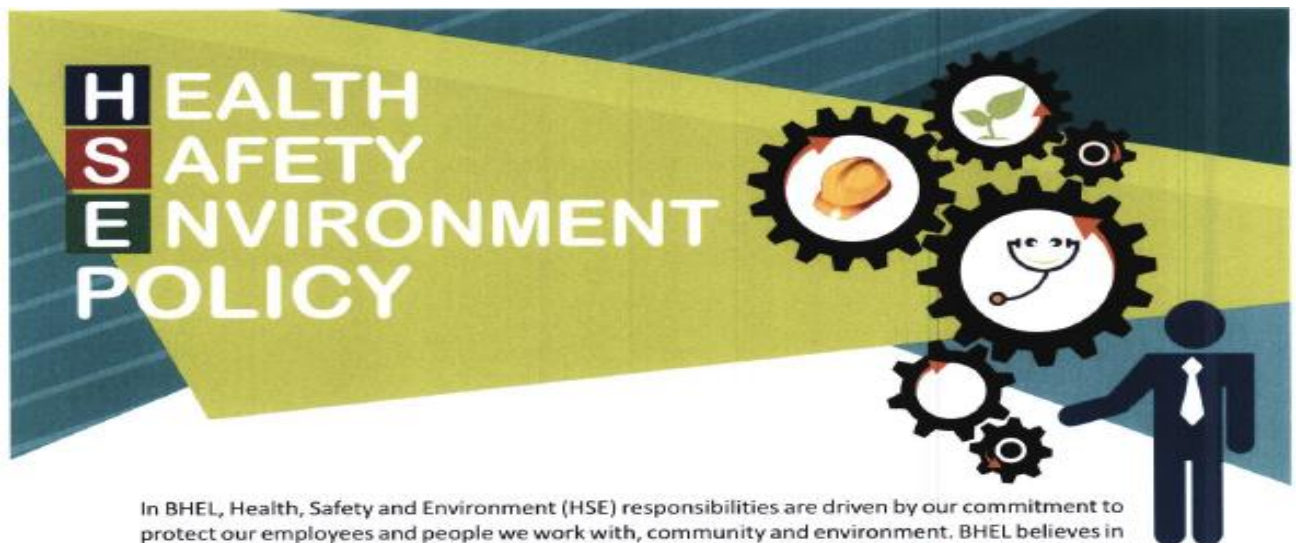

In BHEL, Health, Safety and Environment (HSE) responsibilities are driven by our commitment to protect our employees and people we work with, community and environment. BHEL believes in zero tolerance for unsafe work/non-conformance to safety and in minimizing environmental footprint associated with all its business activities. We commit to continually improve our HSE performance by:

- Developing safety and sustainability culture through active leadership and by ensuring availability of required resources.
- Ensuring compliance with applicable legislation, regulations and BHEL systems.
- Taking up activities for conservation of resources and adopting sound waste management by following Reduce/Recycle/Reuse approach.
- Continually identifying, assessing and managing environmental impacts and Occupational Health & Safety risks of all activities, products and services adopting approach based on elimination/substitution/reduction/control.
- Incorporating appropriate Occupational Health, Safety and Environment criteria into business decisions, design of products & systems and for selection of plants, technologies and services.
- Imparting appropriate structured training to all persons at workplace and promoting awareness amongst customers, contractors and suppliers on HSE issues.
- Reviewing periodically this policy and HSE Management Systems to ensure its relevance, appropriateness and effectiveness.
- Communicating this policy within BHEL and making it available to interested parties.

June 5, 2018

Atul Sobti  
Chairman & Managing Director

Creating  of tomorrow

	<b>Transmission Business Group</b> <b>HSE Department, HQ, Noida</b>	<b>Doc No.</b> TBG/HSE/NIT-01 <b>Rev No. :</b> 02 <b>Date:</b> 31.01.24
	<b>HSE Conditions at a Glance for Bidders</b>	Page- 3 of 18

## 2. Legal Compliances:

- a. **Statutory Provisions:** All the sub-contractors are to comply with client specific rules and procedures, the National legislations and codes, in particular the following or their revised versions:

Srl. No	Acts/Rules Name	Srl. No	Acts/Rules Name
1	The Factories Act 1948, Amendment Act 1947	11	Contractor labour Act, 1970 (Regulation and abolition)
2	The Environment Act 1986	12	Provident fund Act, 1952
3	Workmen's Compensation Act, 1923	13	Payment of gratuity Act, 1972
4	Building and Other Construction Workers (Regulation of employment and condition of service) Act, 1996	14	Indian Explosives Act and the explosives Rules 2008
5	Buildings and Other Construction Workers Welfare Act, 1996	15	The Gas Cylinder Rules, 2016, Static and Mobile Pressure Vessels (Unfired) Rules 2016
6	Payment of wages Act, 2017 Equal remuneration Act,	16	The Indian Electricity Act 2003 and Indian Electricity Rules 2005
7	Minimum wages Act.1948	17	The Atomic Energy Act, 2015
8	Employers liability Act, 1938	18	The atomic energy (Radiation Protection) Rules. 2004
9	Industrial dispute Act, 1947	19	National Fire Protection Association (NFPA),
10	maternity benefit amendment act 2017	20	National Building Code of India 2016 etc.

b. **Indian Standard (IS) Codes related to HSE**

All the sub-contractors are to comply with client specific rules and procedures, the National legislations and codes in particular the following or their revised versions:

Srl	IS Code	Applies on
1	IS: 4081 -1986	Safety code for Blasting and Related Drilling operations
2	IS: 3764 -1992	Safety code for excavation work



**Transmission Business Group**

**HSE Department, HQ, Noida**

**Doc No. TBG/HSE/NIT-01**

**Rev No. : 02**

**Date: 31.01.24**

**HSE Conditions at a Glance for Bidders**

Page- 4 of 18

3	IS: 5121 -1969	Safety code for piling and other deep foundations
4	IS: 2750 -1964	Specification for steel scaffoldings
5	IS: 3696 (Part-I)-1987	Safety code for scaffolds and Ladders: Part- I Scaffolds
6	IS: 3696 (Part-II) -1991	Safety code for scaffolds and Ladders: Part –II Ladders
7	IS: 4082 -1977	Recommendations on stacking and storage of construction materials at site (First revision)
8	IS: 4130-1976	Safety code for demolition of building (First revision)
9	IS: 4912-1978	Safety requirements for floor and wall openings, railings and toe boards (First revision)
10	IS: 5916- 1970	Safety code for constructions involving use of hot bituminous materials
11	IS: 7205 -1974	Safety code for erection of structural steel work
12	IS: 7969 -1975	Safety code for handling and storage of building materials
13	IS: 8989 -1978	Safety code for erection of concrete framed structures
14	IS: 7293 -1974	Safety code for working with construction machinery
15	IS: 2212 -1991	Pipe lines –Identification –Colour code
16	IS: 5216 -1982	Recommendations on safety procedures & practices in Electrical works (Part -I &II)
17	IS: 875 -1964	Code of practice for structural safety of buildings and loading standards
18	IS: 10386 -1983	General aspects Part-1 -1983, Part-2 -1982, Part-6 -1983, Part-10 -1983- Amenities, Protective clothing and equipment, construction, storage, handling, detection and Safety measures for gases, chemicals and flammable liquids
19	IS: 10500-2012	Drinking water (Specification)
20	IS: 10291 -1982	Code of dress in civil engineering works
21	IS: 2925-1984	Safety helmets
22	IS: 1179-1967	Welding helmets
23	IS: 7524 -1979 (Part-I)	Safety goggles
24	IS: 9167 -1979	Ear muff /Ear plugs
25	IS: 6994 -1973 (Part-I)	Canvas hand gloves, Cotton hand gloves, Chrome leather gloves
26	IS: 4770 -1991	Rubber hand gloves tested for 15,000 volts
27	IS: 3521 -1999	Full body safety harness
28	IS: 11057 -1984	Specification for Industrial safety nets

	<b>Transmission Business Group</b> <b>HSE Department, HQ, Noida</b>	<b>Doc No.</b> TBG/HSE/NIT-01 <b>Rev No. :</b> 02 <b>Date:</b> 31.01.24
	<b>HSE Conditions at a Glance for Bidders</b>	Page- 5 of 18

29	IS: 13415 -1992	Protective Barriers in & around buildings (Code of safety)
30	IS: 13416 -1992	Preventive measures against Hazards at work places-Recommendations part-I Falling materials hazards Prevention part-I
31	IS: 13416 -1992	Preventive measures against Hazards at work places-Recommendations part-II Fall Prevention
32	IS: 15298 -2011 (Part 1&2)	Personal Protective Equipment -Safety shoes
33	IS: 12254 -1993	Poly vinyl chloride (PVC) industrial boots
34	IS: 5557:2004	Industrial and Protective Rubber knee and Ankle boots
35	IS: 2878 -2004	Co2 Type fire extinguisher
36	IS: 2171 -1999	Dry chemical powder fire extinguisher
37	IS: 13849 – 1993	Fire extinguisher for ABC fires
38	IS: 10204-2001	Mechanical Foam type extinguisher (Foam used shall conform to IS: 4989 -1974 and Co2 cartridge shall conform to IS: 4947 -1985)
39	IS: 3786 -1983	Methods for computation of Frequency rate and Severity rates for Industrial injuries and classification of Industrial accidents (First revision)

#### c. The Sub-contractors need to

- Attend HSE familiarization program at TBG-HQ with his site management team. This will be a half day long awareness session on HSE requirements and compliances which the agency is supposed to fulfil during contract execution at site. The session shall be taken by TBG HSE department on intimation by TBSM. **(Rev-01)**
- Request for issuance of Form-V in their name from customer on behalf of BHEL
- Get the Labour license registration from concerned Labour office.
- Get the BOCW Registration done along with the labour license.
- Get their labourers registered under BOCW for benefits provided by the office.
- Maintain Seven registers of labours as per BOCW requirement.
- Ensure payment of wages to labours not less than the current minimum wages applicable in the premises.
- Ensure PF deduction of labourers and submission of proof to BHEL office (Wage sheet, ECR & Challan copies) duly signed.
- Submit Labour Payment Certificate by 10th of Every month.
- File timely returns, get renewals done and submit a copy to BHEL office.

	<b>Transmission Business Group</b> <b>HSE Department, HQ, Noida</b>	<b>Doc No.</b> TBG/HSE/NIT-01 <b>Rev No. :</b> 02 <b>Date:</b> 31.01.24
	<b>HSE Conditions at a Glance for Bidders</b>	Page- 6 of 18

- Get Workmen's Compensation policy before the start of work, covering all the labourers and staff,
  - Policy should clearly mention the project name and location,
  - should be as per labour class and wage.
  - Should cover all the height workers with clear mention of Max. height.
  - Policy should be submitted to BHEL office and renewal before expiry.
- Issue employment card to every worker.

### 3. Labour Welfare and Medical Facilities

#### a. Labour Welfare

1. Declaration of normal working hours and weekly off day, Payment day & intervals
2. Paid rest days & holidays.
3. Payment of overtime @ twice the normal wage rate.
4. No labour shall be allowed overtime >12 hrs/week, limited to 48 hrs/month.
5. Rest and lunch area.
6. Separate Male/Female Toilets and Lavatories, clearly marked in local Language and provided with signage.
7. Cold and clean drinking water facility suitable to strength and near workplace
8. Creche for children of female workers as per BOCW requirements
9. Arranging labour accommodation in hygienic environment with the facilities of Water (Drinking, Sanitation), washing and bathing area, toilets in sufficient nos., clean and safe camps and surrounding, access road, well illuminated camp and roads, mode of contact, transport facility, first aid centre, 24x7 Security etc.
10. Cooking and eating place to be maintained in hygienic condition
11. General awareness of health and hygiene.

	<b>Transmission Business Group</b> <b>HSE Department, HQ, Noida</b>	<b>Doc No. TBG/HSE/NIT-01</b> <b>Rev No. : 02</b> <b>Date: 31.01.24</b>
	<b>HSE Conditions at a Glance for Bidders</b>	<b>Page- 7 of 18</b>

#### b. Medical facilities and Health centres

- Availability of first aid box at every work location and agency office, with contents as per BOCW requirement.
- Emergency vehicle (four-wheeler) at work place
- Availability of stretchers in emergency vehicle and in office.
- Trained first aider
- Medical check-up for all the supervisors and workers including cooks, at the time of induction and annually thereafter.
- Tetanus Vaccination for all in every six months.
- Identification and tie-up with nearby reputed hospital(s) and display of their contact number in Emergency contact list.

## 4. House Keeping & Storage

Housekeeping is a continuous process and is the part of work. Agencies shall maintain safe and presentable housekeeping all the time in their respective areas, common work locations and passage areas. Roads, passages, staircases, entrance/exit gates shall always be maintained obstruction free. No material shall be left or stacked at the roof edges. Agency shall make arrangements to remove scraps on regular basis and dispose them at a space provided by customer, clearly fenced and marked by the sub-contractor as “**SCRAP YARD**”. Suitable arrangement like dedicated housekeeping team and tractor/hydra should be identified for this work.

Construction materials like shuttering materials, staging materials, cables, re-bars, cements bags, earthing flats and rods, FF pipes, surplus soil etc should be stored/stacked properly such that it should neither pose threat to safety of man nor should obstruct the free movement of man and machineries.

Every sub-contractor should have separate and well-maintained storage area for his own materials, T&Ps, PPEs and BHEL issued materials. Consumables like diesel, cotton, grease, oil, paint, admixtures and other fire potential materials should be stored separately with suitable firefighting facility.

Fire capacity of store area to be assessed and accordingly fire extinguishers shall be planned suiting the class and capacity of fire. Sand heaps may also be stacked in open store yards suitably to use in case of fires.

	<b>Transmission Business Group</b> <b>HSE Department, HQ, Noida</b>	<b>Doc No.</b> TBG/HSE/NIT-01 <b>Rev No. :</b> 02 <b>Date:</b> 31.01.24
	<b>HSE Conditions at a Glance for Bidders</b>	Page- 8 of 18

## 5. Site Safety

### a. Induction and others safety trainings

Every sub-contractor shall make arrangement to provide induction training as per BHEL and/or customer requirement on a pre-approved and fixed module to all its new inductees irrespective of class or grade of appointment/hire. He shall also arrange the required facilities for induction training such as board, marker, dummy, posters/banners with all the mandatory PPEs.

Sub-contractor shall also arrange for periodic trainings on fire-fighting, first aid, CPR, importance and use of PPEs, electrical safety, hot work safety, Height work safety, confined space, deep excavations and barricading, concreting work safety etc.

### b. Appointment of Safety Officer/Supervisor

Every sub-contractor shall appoint full time **safety officer(s)** as per **Schedule VIII of BOCW Act-1996**. The safety officer so appointed, shall not be assigned any duty/work other than assisting in fulfilment of legal and contractual obligations at site. He shall perform his duties in line to meet the requirements of TBG HSE MANAGEMENT SYSTEMS, such as ensuring daily TBT, conducting induction and other HSE training and awareness programs, organising HSE campaigns, health check-ups, periodic mock drills, reporting & record keeping and other such compliances as per **HSE Plan for Site Operation (TBG/HSEP-14)** on regular basis. **(Rev-01), (Rev-02)**

### c. Safety organisation, Safety committees and meetings

Safety officer shall report directly to the head of the projects of the sub-contractor management. There shall be some appointed or nominated **safety stewards** from each sub-group like shuttering, bar-bending, concreting, brick work, material handling, structure erection, cable laying, pipe work, maintenance, batching plant, housekeeping, etc.

A **safety committee** shall be formed including members from different agencies, BHEL and customer covering at-least 50% participation from workers. Safety committee shall meet on weekly basis or as may be decided by customer, outcomes shall be complied as committed.

### d. Personal Protective Equipment.

Unless mentioned otherwise, there will be three mandatory PPEs- Safety shoes, Safety Helmet and Reflective jackets conforming to relevant IS codes as mentioned above. Every person entering in the project premises shall use above mandatory PPEs.

There will be other PPEs too, based on the work requirement like: Twin lanyard full body harness, fall arresters and life lines for height workers, Face shield for welders and grinders, Induction helmets and Electrical resistant shoes with FRP/PVC toe for electricians and commissioning engineers, Gum boots for concrete workers and manual excavators, Goggle for gas cutters and grinders, Aprons for welders, shoulder pads for material handlers, Hand gloves – Leather for binders/welders/grinders, certified Rubber gloves for electricians, PVC for concrete/cement

	<b>Transmission Business Group</b> <b>HSE Department, HQ, Noida</b>	<b>Doc No.</b> TBG/HSE/NIT-01 <b>Rev No. :</b> 02 <b>Date:</b> 31.01.24
	<b>HSE Conditions at a Glance for Bidders</b>	Page- 9 of 18

handlers, cotton-housekeeping team/brick coolies/erectors, cable laying men and other material handlers. Dust mask for cement handlers.

#### e. Material Handling

BHEL as a policy discourages continuous manual handling. Material handling contributes a major portion in the project and hence proper means (mechanical/ electrical powered) should be deployed appropriately for this work. Cranes/Faranas/hydras should not be used for material transportation for long distances(>100m), if such movement is un-avoidable, it must be accompanied by a trained signal man. Long materials should be guided by tagline. Roads for material movement should be free from obstructions. Lifting appliances must be in good condition and must have test/inspection certificates.

Lifting tackles like- D-shackles, chains, ropes, slings, belts shall be periodically inspected and shall have valid test certificate and/or third-party inspection certificates.

Painted/galvanized structures/materials to be lifted by adequate capacity nylon belts only.

If a machine undergoes a major maintenance, fresh TPI shall be required before use.

Hydraulic/pneumatic machines shall be free from leakages. Daily checklist to be filled and witnessed by the concerned supervisor before start of the work.

#### f. Vehicle/Machinery Documents and other safety requirements

- **Crawler mounted boom cranes/Tyre mounted telescopic cranes/tower cranes**
  1. Valid third-party inspection certificate.
  2. Valid Insurance policy
  3. Registration Certificate (if applicable)
  4. Valid Pollution under control (PUC) (if applicable)
  5. Fitness certificate from RTO (if applicable)
  6. Operator's valid license, experience and/or competence certificate.
  7. Swing horn
  8. Reverse horn
  9. Boom aviation light
  10. Approved Load chart (inside cabin)
  11. Fire extinguisher (inside cabin)
  12. First aid kit (inside cabin)
  13. Boom angle indicator
  14. Hook Latch
  15. Reflector strips on around cabin and on boom
- **Loader backhoe (JCB), crawler excavators (Poclain), Hydra,**
  1. Valid third-party inspection certificate.
  2. Valid Insurance policy
  3. Registration Certificate (if applicable)
  4. Valid Pollution under control (PUC) (if applicable)

	<b>Transmission Business Group</b> <b>HSE Department, HQ, Noida</b>	<b>Doc No.</b> TBG/HSE/NIT-01 <b>Rev No. :</b> 02 <b>Date:</b> 31.01.24
	<b>HSE Conditions at a Glance for Bidders</b>	<b>Page-</b> 10 of 18

5. Fitness certificate from RTO (if applicable)
6. Operator's valid commercial license, experience and/or competence certificate.
7. Reverse horn
8. Approved Load chart (inside cabin) (Hydra)
9. Fire extinguisher (inside cabin)
10. First aid kit (inside cabin)
11. Hook Latch (Hydra)
12. Reflector strips on around cabin and on boom

- **Tipper, Transit mixtures (TM), Self-loading concrete mixture (Ajax Fiori), Tractors**

1. Valid third-party inspection certificate.
2. Valid Insurance policy
3. Registration Certificate
4. Valid Pollution under control (PUC)
5. Fitness certificate from RTO
6. Operator's valid commercial Heavy license, experience and/or competence certificate.
7. Reverse horn
8. Fire extinguisher (inside cabin)
9. First aid kit (inside cabin)
10. Reflector strips on around cabin and on body

**Note: 1. Tractors may be allowed with Light Commercial/non-commercial license on customer's consent.**

- **Cars, Taxis, scooters, motor cycles and other public carriers**

- Valid 2/4-wheeler license (as applicable- commercial/non-commercial)
- Registration Challan
- Valid Insurance
- Pollution under control

**g. Man-lifts (Cherry pickers), Scissors Lifts**

1. Trained operator with experience/competence certificate and license
2. Valid third-party inspection certificate.
3. Valid Insurance policy
4. Registration Certificate (if applicable)
5. Valid Pollution under control (PUC) (if applicable)
6. Swing horn
7. Reverse horn
8. Boom aviation light
9. Fire extinguisher (inside cabin)
10. First aid kit (inside cabin)
11. Reflector strips on around cabin and on boom

	<b>Transmission Business Group</b> <b>HSE Department, HQ, Noida</b>	<b>Doc No.</b> TBG/HSE/NIT-01 <b>Rev No. :</b> 02 <b>Date:</b> 31.01.24
	<b>HSE Conditions at a Glance for Bidders</b>	Page- 11 of 18

**Note:**

1. No one shall ride man-lift bucket without safety belt, safety shoes, helmet and reflective jacket.
2. Not more than 3 persons at a time will board in bucket of man-lift (without any heavy materials) including operator.
3. Operator will not leave the machine while persons are elevated and working.
4. No one other than the authorised operator will operate the man lifts/Scissors lifts.

**h. Excavation**

Prior permission/clearance from customer is a must for excavations in areas where underground service services such as gas/water/oil/chemical/electrical lines may be routed. Due precautions shall be taken during excavation in such area. Excavations near water bodies (ponds/canals etc.) shall be done with sand/soil bags ready to plug water from accidental damaged/burst of edges. All the excavations shall be done by either step cutting (min. 600mm step at every 1.5m depth) or slope cutting at 1:2(X:Y axis) (or greater depending upon the soil condition). Where step cutting/slope cutting is not possible due to space constraints, shoring/shuttering or sheet piling to be used to check collapse of soil.

Excavated soil shall be stacked away from edge of the pit, at-least 1.5 meters or half of the depth whichever is higher. Height of the stack shall not exceed 2m in height.

Ramps shall be provided for access of the workers in large pits and ladder of metal/good built for small pits. Ladders shall be of sufficient length protruding at least 1m above the ground level.

Pumps of adequate capacity shall be available for pumping out of water. No lone worker shall be allowed to work in any excavation. Overloaded vehicle shall not be allowed near excavated pits.

**i. Bar bending and Binding**

Bar bending machine shall be installed under shed/roof. It shall be properly earthed and maintained for operation. Housekeeping of the area shall be team's responsibility on daily basis. All be bar benders shall be given hand gloves (leather/cotton) in addition to mandatory PPEs. Scrap shall be segregated and moved to scrap yard on regular basis. Bar bending station shall be located away from Main plying roads/passages. The station shall be well illuminated, shall have a maintained first aid kit and potable water. Station shall be located in such a way that the movement of the material be minimised.

**j. Concreting**

**No electric vibrators** shall be allowed to use. All the concrete workers shall be issued gum boots, safety helmets, reflective jackets and PVC hand gloves. Free fall of concrete from chute shall not exceed 1m in height. Heavy machineries/ vehicles shall be kept at least 2m away from the edge. Emergency vehicle shall be available near concreting work. Late night works shall be avoided, if it is unavoidable, a prior permission from BHEL/Customer is mandatory.

	<b>Transmission Business Group</b> <b>HSE Department, HQ, Noida</b>	<b>Doc No.</b> TBG/HSE/NIT-01 <b>Rev No. :</b> 02 <b>Date:</b> 31.01.24
	<b>HSE Conditions at a Glance for Bidders</b>	Page- 12 of 18

#### k. Welding, Gas Cutting & other hot works

**Welding:** Only experienced welders should be deployed for welding jobs. Welders shall be provided with apron, hand gloves, arm pads, leg pads, face shield and safety shoes. Welding leads shall be joint less and insulated. Power input point shall be fully covered at machine.

**Gas cutting:** If LPG is being used, domestic cylinder is strictly prohibited inside the project premises, (not allowed for site kitchen too). Hose pipes shall be in good condition without cracks, cuts, punctures or joints. Ends should be clamped with worm clamps. Dial gauges shall be of good quality and duly calibrated. Flash back arresters is a must for both oxygen/acetylene or LPG/Oxygen combination. Cylinders shall be stored, transported and used in vertical position only. When not in use, they shall be capped. Empty and filled cylinders to be stored separately with distinct marking.

Cylinders shall neither be rolled on the ground nor thrown during loading/unloading.

**Grinding:** Grinder shall be given clear glass face shield, apron, safety shoes, ear muffs and hand gloves. Grinder machines shall have wheel guard. Plug tops to be used for power connection preferably three wire type. Only trained persons shall be allowed to use grinders, abrasive cutters. Electrical connection shall be free from cuts, joints etc.

#### l. Erection & Height Work

Only trained filters and experienced helpers shall be engaged in erection work. Step bolts of lattice towers shall be checked for full tightness with spring washers before use. Height pass shall be issued to the identified group of erectors who have passed medical test and have working experience at height. Name of such workers shall be displayed at appropriate place. These workers only shall be allowed to work at height. Height work shall not be permitted in high wind/bad weather condition, during raining or in night/dark.

#### m. Electrical Safety

BHEL usually provided single point power source and sub-contractors draw power from there. Otherwise agencies make their own arrangement for construction power like DG sets etc. Sub-contractors shall submit their load requirement (amperage & phase) to BHEL before start of work. Accordingly, they shall make arrangements to draw power and distribution arrangements too in a safe way. MCCBs and HRC fuses to be put in circuit for short circuit and overload protections and RCCBs of 30mA sensitivity to be put at each distribution panel for human safety. Earthing pits shall be installed at each distribution point and maintained below three Ohm resistivity which shall be inspected randomly. The distribution points shall be clean, free from vegetation and water logging, easily accessible and covered/protected from three sides and top for rain. Earthing of DBs shall be done by 25x3mm GI flats connected from proper earth pits. Insulation mat, PVC Sheet/Wooden plank to be placed before DBs as platform. DB Sheds shall be legibly marked with name of agency, contact no of electrician and SLD of that DB. Only industrial plugs and sockets shall be allowed. Three wire (Phase, neutral and earth) system shall be used for tools, lights and machineries and two wire power draws shall be strictly prohibited. PTW and LOTO system shall be maintained to work on LT system. Name and contact no of authorised electricians who will be responsible of electrical power facility maintenance shall be submitted to BHEL by Agencies. Unauthorised sharing of power from one agency to other is strictly prohibited. Electricians shall use standard PPEs and insulated

	<b>Transmission Business Group</b> <b>HSE Department, HQ, Noida</b>	<b>Doc No.</b> TBG/HSE/NIT-01 <b>Rev No. :</b> 02 <b>Date:</b> 31.01.24
	<b>HSE Conditions at a Glance for Bidders</b>	<b>Page-</b> 13 of 18

tools only. Standard and tested/certified discharge rods to be used in the areas where there is a possibility of residual current or induction charge. The induction rod to be connected to the earth first and removed in the last. Induction helmets only to be used in the charged area. Electricians to be provided with electrical resistant safety shoes having FRP/PVC toe.

#### **n. Dust Gases and fumes**

Sub-contractor shall make arrangements to avoid accumulation of dust fumes and gases. Cement handlers inside store or at batching plant and gravel spreader shall be given effective nose masks and jaggery (at least 200g per person per day). DG sets and other machineries like cranes excavators etc. shall have valid and effective PUC certificate and shall have maintained engine with silencer. No IC engine operated machine shall be used in confined and covered area like hall, sheds, store etc. where accumulation due to lack of ventilation can increase to harmful levels. Dedicated arrangements (tanker or tractor with sprinkler) shall be made by the sub-contractors (individual or jointly) to continuously subside the dusts arising out of the movement of the vehicle's roads/passages. Welding activities near roof accumulates harmful gases. Welders in such positions shall be provided with effective masks conforming to IS standards.

#### **o. Vehicular Traffic**

Speed limits defined within the premises shall strictly be followed by the drivers/commuters of construction as well as other vehicles.

Every construction machinery, man-lift shall display the name, contact no and passport size photograph of the authorised operator (There can be one or more authorised operators).

No one other than operator and co-operator shall sit inside the cabin of any construction machine while it is working.

Construction machineries (tractor, trucks, tippers, JCBs, hydra, Fassi cranes etc. shall never be used as mode of public transport. Machineries like Ajax Fiori and hydra shall not be driven in back direction except for small distances. No overloaded vehicle shall be permitted entry in the project premises.

Over speeding shall be reported and driver/operator shall be barred from entry or shall be penalised.

Drunken drivers shall be barred from entry in the project.

Carrying harmful weapons like knives (>6"), guns etc. shall permanently disqualify the person from entry in project premises.

#### **p. Barricading and floor openings**

Every pit deeper than 4 feet (1.2m) shall be barricaded immediately after excavation and will remain barricaded till backfilling.

Pits/trenches drains near roads, passages whether temporary or permanent shall be hard barricaded and well illuminated. Roof edges and openings shall be strictly hard barricaded and illuminated. Height works like masonry works, structure erection, erection by cranes, Lattice tower/beam erection areas shall be barricaded to restrict entry. Areas under charging/commissioning shall be barricaded and caution boards shall be displayed on newly charged areas.

	<b>Transmission Business Group</b> <b>HSE Department, HQ, Noida</b>	<b>Doc No.</b> TBG/HSE/NIT-01 <b>Rev No. :</b> 02 <b>Date:</b> 31.01.24
	<b>HSE Conditions at a Glance for Bidders</b>	Page- 14 of 18

#### q. Scaffold & Ladder

**No bamboo/wooden scaffold** shall be allowed to be used. Only tubular steel scaffolds with couplers conforming to the relevant IS codes shall be allowed with base plates. Standard steel or wooden planks to be used as platforms and no packing materials shall be used. All the platforms shall be built with provisions of **top rail at 1m height, mid rail at 0.5m height and toe boards of min 6" height** at floor level. Minimum width of platform shall be 900mm and if wheel barrow is to be used then 1200mm. Means of access to be provided in the form of ladders, ramps or staircase. Multilevel work platforms or those platforms having passage underneath shall be provided with safety net, screen or canopy at each level for protection from falling objects. Platforms shall be free from concrete, debris or other materials. Platforms shall not extend out of the putlogs and shall be secured and fastened. Decking shall be made non-skidding.

Scaffolds under erection shall be tagged "**RED**", under repair/maintenance/inspection shall be tagged "**YELLOW**" and ready for use shall be tagged "**GREEN**"

Only metal ladders in the construction site and FRP ladders in charged areas shall be allowed. Ladders made from packing materials shall not be used. Ladders shall be securely fixed at bottom, top and long ladders at middle points too at an interval not more than 2400mm and must have a landing at every 6m. Inclination angle should be approximately 1:4 (X:Y) or 75deg. Ladder must extend at least 1m above the platform/access area. Gap between two rungs shall not exceed 300mm. Portable ladder should not be more than 4m in length. Minimum width of the ladder shall not be less than 300mm.

Use of Mobile aluminium scaffold is preferably advisable for erection of transformers/reactors.

#### r. Illumination

The sub-contractor shall ensure that the areas such as work stations, buildings, batching plants, passages/roads, stores, rest areas, power sources, staircases etc. are illuminated sufficiently to make safe work conditions at site and shall not be less than the relevant IS standards. Excavations/ below ground level structures near passages/roads shall also be sufficiently illuminated.

#### s. Safety banners/posters, caution boards

Sub-contractors shall display boards and banners in sufficient quantity having safety signs, slogans, important messages, pictures, cautions at prominent locations to promote safety and spread awareness for important precautions such as "Deep Excavation Ahead", "Speed Limit", "Charged Area", "Do not operate", "Hard hat area", "No smoking Zone" etc. Boards containing messages of Emergency contacts, First aid facility, rates of minimum wages, working hours, rest day etc. should be displayed at specific areas.

#### t. Waste management and disposal

Sub-contractor shall make suitable and effective arrangement to remove waste material from site on regular basis and store them in an identified and safe location. Disposal of wastes shall also be done as per manufacturer's instructions or as per the guidelines laid by legal authorities. Re-bars, Cement bags, packing material (wooden/metal/plastic/paper), paint, oil, grease, cables (armour, sheathing, insulation),

	<b>Transmission Business Group</b> <b>HSE Department, HQ, Noida</b>	<b>Doc No. TBG/HSE/NIT-01</b> <b>Rev No. : 02</b> <b>Date: 31.01.24</b>
	<b>HSE Conditions at a Glance for Bidders</b>	<b>Page- 15 of 18</b>

civil debris, metal chips, GI sheet scraps, batteries etc. are the common waste materials. Sub-contractor shall arrange disposal of the hazardous wastes/materials in conformance to the legal and contractual requirements only.

#### **u. Inspection of PPEs, T&Ps, Machineries and lifting appliances**

All the PPEs, T&P and lifting appliances purchased newly by sub-contractors shall have test certificates which shall be submitted to BHEL office periodically or on demand. There shall be at least monthly joint inspection schedule for inspection of healthiness of all the PPEs, T&Ps and lifting appliances. All the lifting appliances shall be tested and examined by a competent person before taking into use for the first time or after it has undergone any alterations or repairs liable to affect its strength or stability

and also once at least in every twelve months. To confirm quality of the PPEs as per the relevant IS codes, BHEL may ask sub-contractors to get any or all types of PPEs tested through NABL approved lab as per relevant IS codes. At any stage, the 100% cost of such tests shall be in the scope of respective sub-contractors.

#### **v. Cable Laying**

Sub-contractor shall ensure cable trenches free from water, mud, debris, snakes, Scorpios, lizards before start of the work in trenches. Cable drum rollers shall be used to pull cables out of drums to avoid twisting of cables. Hand gloves, Safety shoes/gum boots, reflective jackets, safety helmets shall be provided to the workers. Cable laying area shall be well illuminated.

#### **w. Fire Protection**

Every sub-contractor has to maintain their working area, store and office area free from bushes. Stacking of flammable materials like wood, paper, plastic, paint, oil, grease, fuel, cotton, gases etc. at isolated place disconnected from other storage and office areas. Adequate arrangements of firefighting means like suitable extinguishers, fire/water buckets, water tanks, sand dunes etc. shall be made by the agency depending upon the fire capacity assessed or as per MSDS. Fire drills and trainings on how to operate fire extinguishers and how to react in case of fire breakouts shall be the part of regular training program. Guards and store persons must be a regular participant of such training programs. A list of trained firefighting persons and periodicity of such training programs shall be submitted to BHEL by every agency and same to be adhered. Sufficient number of fire extinguishers with suitable class shall be placed at such locations where there can be fire hazard like stores, pantry, office, DG set, electrical distribution panels etc.

#### **x. Fencing of exposed rotating parts**

Exposed rotating parts poses great threat to the person in vicinity. Such parts need to be fenced/covered. Guards are mandatory of grinders, abrasive cutters. Flywheels of the engines of heavy machines, Diesel engines, DG sets need to be covered. Electric winch machines, pulleys, chains, shafts, exhaust fans at reachable height, table fans, need to be caged/fenced. Such fencing/guard shall not be removed while machinery is in operation.

	<b>Transmission Business Group</b> <b>HSE Department, HQ, Noida</b>	<b>Doc No.</b> TBG/HSE/NIT-01 <b>Rev No. :</b> 02 <b>Date:</b> 31.01.24
	<b>HSE Conditions at a Glance for Bidders</b>	Page- 16 of 18

**y. Emergency preparedness response plan and periodic mock drills.**

Sub-contractor shall comply JSA (Job Safety Analysis) and arrange to mitigate the effects of identified possible hazards. He shall also define following in response to emergency preparedness:

An emergency assembly point and put a board of the same with information to all in induction training.

Have facility of ambulance or tie-up with nearest hospital for service in minimum possible time (Max-30min) if there is not ambulance inside the premises.

Ensure availability of emergency vehicle with driver all the time at site during work.

Conduct mock-drills on possible risks like electrocution, fall from height, fire, heat stroke etc., record responses and take photographs to submit in BHEL office. Stretchers availability in emergency vehicle or at work place should be well accessible. Provide fire extinguishers of right type at right place in right quantity with information to all. Display emergency contact nos. to various risk locations and at office, service building or at major work locations. Provide first aid training by doctors for and display names of such trained first aiders and fire fighters. Rescue kit with trained staff or man lift or both to rescue a man hanging by safety belt at height. Provide running water tap near chemical storage and handling points. Agencies shall follow emergency response plan prepared by BHEL in each area of work, store and office.

**z. Safety reports & Reporting of accidents**

BHEL will provide “formats and checklists” for the purpose of records/documents pertaining to the compliance of aforesaid clauses. Agencies shall be responsible for strict adherence and compliance for timely generation and fill-up of the checklists and reports. These shall be submitted on weekly and monthly basis as specified in the formats.

Agency shall also promote such an environment that the near misses, incidents and accidents are reported by every person, whosoever witnesses them. These shall help in analysing the trend and taking measures in reducing/stopping the accidents/incidents. Initial reporting can be in any form-by call, SMS, WhatsApp, e-mail, letter etc.

Major and fatal accidents or high potential incidents shall be investigated for root cause and outcomes shall be immediately implemented to check recurrences.

## 6. General conditions and penalty clauses

Following are the general conditions:

PPEs shall not only bear the ISI mark but also be conforming to the required standards, 100% compliance of the PPEs is mandatory.

Over speeding of vehicles shall attract penalty/notice and recurrence will attract debarring from entry into project premises.

Hiding of facts like incidents, accidents, fake/forged reports/certificates shall also attract penalty/ notice or both. Only approved third party agencies shall be allowed to inspect the machines, T&Ps. Reports shall directly be sent to BHEL/customers by the third parties.

	<b>Transmission Business Group</b> <b>HSE Department, HQ, Noida</b>	<b>Doc No.</b> TBG/HSE/NIT-01 <b>Rev No. :</b> 02 <b>Date:</b> 31.01.24
	<b>HSE Conditions at a Glance for Bidders</b>	Page- 17 of 18

Insurance and TPIs to be renewed before expiry. Machines, T&Ps shall not be allowed to work if renewal delayed. Continuity of WC policy to be maintained religiously by the respective agencies.

Agency shall submit the status report of his labour license, BOCW registration, WC Policy, insurance & TPI validity on monthly basis with list of machineries and T&Ps

Sub-contractors shall also maintain a buffer stock of all the PPEs in at least 20% excess to the present strength of the work force.

If construction power is not drawn as per the guidelines laid in clause no. 5(m), given above, BHEL may take-up this work at the risk and cost of the agency and/or may withhold a sum of min. Rs. 50,000/- (Rs. Fifty Thousand) or more as the site in-charge deems fit till the system is aligned as per aforesaid requirement.

Agencies shall be responsible for the compliance of the above requirements. Failure in one or more clauses/area shall attract a notice or monetary penalty or a combination of above.

Monitory penalty will be

- Rs. 1000/- per person/incident per day for non-conformity in above areas.
- A Major/severe accident shall attract a penalty of Rs. 2,00,000/- per head
- Fatality or permanent disability with total loss of earning capacity, if any, will attract a penalty of Rs. 5,00,000/- (Rs. Five Lakh).
- Further fatality/permanent disability shall attract double the last penalty imposed on the agency.
- Above penalties are exclusive of medical expenses of the victim or compensation to the family through insurance policy (WC Policy or group insurance).
- **Penalties imposed by customer shall be fully transferable to the sub-contractor. In the event of above cases, penalties shall be imposed whichever will be higher.**
- Evaluation of agency's performance on HSE compliance shall be done as per BHEL guide lines/system.

	<b>Transmission Business Group</b> <b>HSE Department, HQ, Noida</b>	<b>Doc No.</b> TBG/HSE/NIT-01 <b>Rev No. :</b> 02 <b>Date:</b> 31.01.24
	<b>HSE Conditions at a Glance for Bidders</b>	Page- 18 of 18

### Revision History

Revision Date	Revision No.	Old Text	New Text	Reason	Revised by (with sign)
03.05.2019	00	N/A	Full Document	New Release	
12.10.2021	01	Nil	Attend HSE familiarization program at TBG-HQ with his site management team. This will be a half day long awareness session on HSE requirements and compliances which the agency is supposed to fulfil during contract execution at site. The session shall be taken by TBG HSE department on intimation by TBSM. (at page no. 5)	For better understanding of HSE requirements to agency. (HSE Review meeting dated 23.08.2021)	
12.10.2021	01	Edition	Inclusion of penalty provisions in case of non-deployment of safety person(page-8)	Introduction of HSEP-14	
17.01.2024	02	Edition	Appointment and duties of qualified safety officer (Page-8)	As per BOCW 1996	

-:End of Document:-



# BHARAT HEAVY ELECTRICALS LIMITED

TRANSMISSION BUSINESS GROUP

(Subcontract Management)

PLOT NO.- 25, SECTOR-16A, NOIDA-201301

Tender Spec. no.: TBSM/LARA/SURVEY/TENDER/24-25

Date: 09.05.2024

## TERMS & CONDITIONS OF CONTRACT

The following terms and conditions shall form a part of the tender document.

### **1.0 GENERAL INSTRUCTION**

1.1 **All pages of the tender documents shall be duly signed, stamped and submitted along with the offer in token of complete acceptance thereof.** The information furnished shall be complete by itself. The tenderer is required to furnish all the details and other documents as required in the following pages.

1.2. Tenderers are advised to study all the tender documents carefully. Any submission of tender by the tenderer shall be deemed to have been done after careful study and examination of the tender documents and with the full understanding of the implications thereof. Should the tenderers have any doubt about the meaning of any portion of the Tender Specification or find discrepancies or omissions in the drawings or the tender documents issued are incomplete or shall require clarification on any of the technical aspect, the scope of work etc., tenderer shall at once, contact the authority inviting the tender well in time (so as not to affect last date of submission) for clarification before the submission of the tender. Tenderer's request for clarifications shall be with reference to Sections and Clause numbers given in the tender documents. The specifications and terms and conditions shall be deemed to have been accepted by the tenderer in his offer. Non-compliance with any of the requirements and instructions of the tender enquiry may result in the rejection of the tender.

### **2.0 PROCEDURE FOR SUBMISSION OF SEALED TENDERS**

2.1 Bidders may please refer Cl no. 02 to Cl no. 03 of the Notice inviting tender.

2.2 The tenders received after the specified time of their submission shall be treated as 'Late Tenders' and shall not be considered under any circumstances.

2.3 Tenders shall be opened by the officers concerned of BHEL at the time, date and venue as specified in the tender enquiry. Tenderer or their authorized representative may witness the bid opening.

2.4 The tenderer shall closely pursue all the clauses, specifications and drawings indicated in the Tender Documents before quoting. Should the tenderer have any doubt about the meaning of any portion of the Tender Specifications or find discrepancies/omission in the drawings or the tender documents issued are incomplete or shall require clarification on any of the technical aspect, scope of work etc. he shall at once contact the authority inviting the tender for clarification before the submission of the tender.

2.5 Before submission of offer, the tenderers are advised to inspect the work & the environments and be well acquainted with the actual working and other prevalent conditions, facilities available, sourcing of material and labour, means of transport and access to site, accommodation, etc. No claim will be entertained later on the grounds of lack of knowledge on any of these conditions/ resources.

2.6 Tenderer must fill up all the schedules and furnish all the required information as per the instructions given in various sections of the tender specification. Each and every page of the Tender Specification must be SIGNED AND SUBMITTED ALONG WITH THE OFFER by the Tenderer in token of complete acceptance thereof the information furnished shall be complete by itself.



# BHARAT HEAVY ELECTRICALS LIMITED

## TRANSMISSION BUSINESS GROUP

(Subcontract Management)

PLOT NO.- 25, SECTOR-16A, NOIDA-201301

**Tender Spec. no.: TBSM/LARA/SURVEY/TENDER/24-25**

**Date: 09.05.2024**

- 2.7 The tenderer shall quote the rates in English Language and international numerals. Total price offered should be entered in figures as well as in words. For the purpose of the tender, the metric system of units shall be used.
- 2.8 **The tenderer shall quote a percentage above/ below/At Par the rates shown in the “Percentage BOQ/Price Schedule/Price bid” of subject tender.**
- 2.9 **The quoted percentage will apply to all the individual items of “Annexure-I i.e Bill of Quantity Cum Price Schedule” uniformly.**
- 2.10 All entries in the tender shall either be typed or be written legibly in ink. Erasing and overwriting are not permitted and may render such tender liable for rejection. All cancellations and insertions shall be duly attested by the tenderer.
- 2.11 The tenderer must provide the registered e-mail of their registered office along with the addresses and authorized phone/mobile nos.
- 3.0 ADJUSTMENT PRICE DISCREPANCY (IES): - Not Applicable being e procurement.**
- 4.0 EVALUATION OF TECHNICAL BIDS**
- 4.1 Technical Bids submitted by the tenderer will be opened first and evaluated for fulfilling the Pre-Qualification criteria and other conditions in NIT/Tender documents, based on documentary evidences submitted along with the offer.
- 4.2 In case the same qualifying experience is claimed by more than one bidder due to subletting of work by main contractor to subcontractor (s) then following conditions shall be applicable.
- a) For labour + consumable contract without material and T&P:  
Benefit of work experience shall be given to the subcontractor who has actually executed job and not to the contractor offloaded down the line.
- b) For contract with complete scope i.e. with materials, T&P, labour and consumable:
- i) Benefit of work experience shall be given to the subcontractor who has actually executed job and not to the contractor offloaded down the line.
- ii) If the contractor offloads the labour and/or T&P portion only, Benefit of work experience shall be given to the main contractor and not to the subcontractor who has executed only as labour supply contractor
- The bidders qualification shall be subject to submission of documentary proof. BHEL reserves the right to ask for further proofs including submission of TDS certificates/ for the said job.
- 4.3 In case the qualifying experience is claimed by private organizations based on Work Order and completion certificates from another private organization, BHEL reserves the right to ask for further proofs including submission of TDS certificates/ form 26AS /bills for the said job.
- 4.4 Credentials of all the bidders participating in open tender will be scrutinized thoroughly by the nominated committee w.r.t. the pre-qualifying requirement for the tender.
- 4.5 Details of qualifying work(s) executed by the bidder will be forwarded to the principle employer for verification of the work with respect to completion, commencement & completion date, scope and value of the work executed. Performance feedback of the bidder will also be sought from the principle employer.
- 4.6 BHEL may conduct onsite verification of at least one of the qualifying work to verify completion of the work and evaluate capability and performance of the bidder.
- 4.7 The bidder representative may be called for the discussion with the committee. His



# BHARAT HEAVY ELECTRICALS LIMITED

## TRANSMISSION BUSINESS GROUP

(Subcontract Management)

PLOT NO.- 25, SECTOR-16A, NOIDA-201301

**Tender Spec. no.: TBSM/LARA/SURVEY/TENDER/24-25**

**Date: 09.05.2024**

originals may be verified by the committee. In addition to above their organization chart and detailed list of manpower, tools & plants and technical capability may be discussed and ascertained by the committee.

**5.0 EVALUATION OF PRICE BIDS**

5.1 Price Bids of unqualified bidders shall not be opened.

5.2 The offers will be evaluated on the basis of total price basis (refer "BILL OF QUANTITY AND PRICE SCHEDULE) as shown in the price bid.

5.3 Reasons for rejection of the bid shall be intimated in due course after issue of LOI/LOA to successful bidder and receipt of unconditional acceptance of LOI /LOA from the successful bidder

5.4 In case of electronic Reverse Auction, the unqualified bidders shall not be allowed to participate in reverse auction.

**6.0 DOCUMENTS TO BE ENCLOSED:**

Full information shall be given by the tenderer in respect of the following.

6.1 Tenders shall be signed by persons duly authorized/empowered to do so. An attested copy of the Power of Attorney to be submitted in all cases except where the sole proprietor is the signatory to the tender documents

6.2 PERMANENT ACCOUNT NUMBER:

Certified copies of Permanent Account Numbers as allotted by Income Tax Department for the Company / Firm / Individual Partners, etc. shall be furnished along with tender.

6.3 AUDITED BALANCE SHEET AND INCOME TAX RETURN:

Copy of Audited Balance sheets and income tax return for last Five financial years (financial years as specified in PQR)

6.4 SOLVENCY CERTIFICATE:

If asked in NIT, bidder should submit solvency certificate (not older than 12 months from date of tender notification) issued by any scheduled bank.

6.5 DOCUMENT RELATED TO INCORPORATION OF BUSINESS ENTITY:

6.5.1 IN CASE OF INDIVIDUAL TENDERER:

His/her full name, address and place & nature of business.

6.5.2 IN CASE OF PARTNERSHIP FIRMS:

The names of all the partners with address. A copy of the partnership deed/instrument of partnership duly certified by the Notary shall be enclosed.

6.5.3 IN CASE OF COMPANIES:

Date & place of registration including date of commencement certificate in case of Public Companies and the nature of business carried on by the company. Certified copies of Memorandum and Articles of Association are also to be furnished.

6.6 Offer forwarding letter over the letterhead

6.7 Declaration sheets (As per Prescribed format) over the letter head

6.8 No Deviation certificates (As per Prescribed format) over the letterhead

6.9 GST Registration certificate

All the data required to be enclosed with the tender need to be furnished neatly typed, signed & stamped in the given formats only (in the form of separate sheets) failing which the tender may be considered as incomplete and is liable for rejection. Documentary proof wherever necessary also need to be enclosed.



# BHARAT HEAVY ELECTRICALS LIMITED

TRANSMISSION BUSINESS GROUP

(Subcontract Management)

PLOT NO.- 25, SECTOR-16A, NOIDA-201301

**Tender Spec. no.: TBSM/LARA/SURVEY/TENDER/24-25**

**Date: 09.05.2024**

**7.0 REJECTION OF TENDER & OTHER CONDITIONS:**

- 7.1 The decision of acceptance of tender will rest with BHEL which does not bind itself to accept the lowest tender or any tender and reserves to itself full rights for the following without assigning any reasons whatsoever:
- (a) To reject any or all of the tenders.
  - (b) To split up the work amongst two or more Tenderer as per NIT
  - (c) To award the work in part as per NIT
  - (d) In either of the contingencies stated in (b) and (c) above to modify the time for completion suitably.
- 7.2 Conditional tenders, unsolicited tenders, containing abnormally low/ unworkable rates & amounts, tenders which are incomplete or not in the form specified or defective or have been materially altered or not in accordance with the tender conditions, specifications etc. are liable to be rejected.
- 7.3 Tenders are liable to be rejected in case of unsatisfactory performance of the tenderer with BHEL, or tenderer under suspension (hold / banning / delisted) by any unit / region / division of BHEL or tenderers who do not comply with the latest guidelines of Ministry / Commissions of Govt. of India. BHEL reserves the right to reject a bidder in case it is observed that they are overloaded and may not be in a position to execute this job as per the required schedule in line with 'NIT'. The decision of BHEL will be final in this regard.
- 7.4 In case of any adverse information is received concerning performance, capability or conduct of the tenderer after issue of tender enquiry or opening of tender or award of work, BHEL reserves the right to reject the offer at any stage as deemed fit.
- 7.5 Offers with inadequate Tools & Plants, Manpower Deployment Plan, and Method Statement are liable for rejection.
- 7.6 If a tenderer who is a proprietor expires after the submission of his tender or after the acceptance of his tender, BHEL may at its discretion, cancel such tender. If a partner of a firm expires after the submission of the tender or after the acceptance of the tender, BHEL may cancel such tender at its discretion unless the firm retains its character.
- 7.7 BHEL will not be bound by any Power of Attorney granted by the tenderer or by changes in the composition of the firm made subsequent to the execution of the contract. BHEL may, however, recognize such Power of Attorney and changes after obtaining proper legal advice, the cost of which will be chargeable to the contractor concerned.
- 7.8 If the tenderer deliberately gives wrong information in his tender, BHEL reserves the right to reject such tender at any stage or to cancel the contract, if awarded, and forfeit the Earnest Money/Security Deposit/any other moneys due.
- 7.9 Canvassing in any form in connection with the tender is strictly prohibited and the tenders submitted by the tenderer who resorts to canvassing are liable to be rejected.
- 7.10 In case the Proprietor, Partner or Director of the Company / Firm submitting the Tender, has any relative or relation employed in BHEL, the authority inviting tender shall be informed to the fact as per specified format along with the offer, failing this, BHEL may, at its sole discretion reject the tender or cancel the contract and forfeit the Earnest Money/ Security Deposit.
- 7.11 The successful tenderer should not sub-contract the part or complete work detailed in the tender specifications without written permission of BHEL's Site In charge/ Sector Head. For this the contractor shall submit request application to site in charge supported by credentials



# BHARAT HEAVY ELECTRICALS LIMITED

TRANSMISSION BUSINESS GROUP

(Subcontract Management)

PLOT NO.- 25, SECTOR-16A, NOIDA-201301

**Tender Spec. no.: TBSM/LARA/SURVEY/TENDER/24-25**

**Date: 09.05.2024**

(financial and technical) and resource mobilization schedule of such sub-contractor. Such request is to be considered in consultation with end user/ultimate customer (if applicable) and subject to satisfactory credentials, fund flow arrangement between them, HSE and other contractual and statutory obligations. The tenderer is solely responsible to BHEL for the work awarded to him.

7.12 The Tender submitted by a tenderer shall become the property of BHEL who shall be under no obligation to return the same to the bidder. However unopened price bids and late tenders shall be returned to the bidders.

7.13 unsolicited discount received after the due date and time of Bid Submission shall not be considered for evaluation. However, if the party who has submitted the unsolicited discount/rebate becomes the L-I party, then the awarded price i.e contract value shall be worked out after considering the discount so offered.

7.14 BHEL shall not be liable for any expenses incurred by the bidder in the preparation of the tender irrespective of whether the tender is accepted or not.

8.0 **NO DEVIATIONS ARE ACCEPTABLE:** -

Offers with deviations are likely to be rejected. However, if the bidder insists on any technical or commercial deviations from the specifications and / or tender conditions, **the price implication, if any, of withdrawing the deviations must be submitted along with the price bid in a separate sealed envelope** super-scribed "**PRICE IMPLICATION FOR WITHDRAWAL OF DEVIATIONS**". No price implication for withdrawal of deviation shall be accepted at a later date, after opening of technical bid.

9.0 Consortium/ JV bidding is not allowed under this NIT.

## **10.0 EARNEST MONEY DEPOSIT**

Not applicable for this tender.

## **11.0 SECURITY DEPOSIT**

Security Deposit means the security provided by the Contractor towards fulfilment of any obligations in terms of the provision of the contract.

Upon acceptance of Tender, the successful Tenderer should deposit the required amount of Security Deposit for satisfactory completion of work. **The total amount of Security Deposit will be 5% of the Contract Value.** EMD of the successful tenderer shall be converted and adjusted towards the required amount of Security Deposit.

### **11.1 Mode of Security deposit:**

The security Deposit should be furnished before start of the work by the contractor.

"Bidders agrees to submit performance security required for execution of the contract within the time period mentioned. In case of delay in submission of Performance security, enhanced performance security which would include interest (Repo rate + 4%) for the delayed period, shall be submitted by the bidder.

Further, if performance security is not submitted till such time the first bill becomes due, the amount of performance security due shall be recovered as per terms defined in NIT / Contract, from the bills along with due interest".

The balance amount to make up the required Security Deposit of 5% of the contract Value may be furnished in any of the following forms:

- i) Cash (as permissible under the extant Income Tax Act)
- ii) Local cheques of scheduled banks (subject to realization) / Pay Order / Demand Draft / Electronic Fund Transfer, in favour of BHEL.



# BHARAT HEAVY ELECTRICALS LIMITED

## TRANSMISSION BUSINESS GROUP

(Subcontract Management)

PLOT NO.- 25, SECTOR-16A, NOIDA-201301

**Tender Spec. no.: TBSM/LARA/SURVEY/TENDER/24-25**

**Date: 09.05.2024**

- iii) Bank Guarantee from Scheduled Banks / Public Financial Institutions as defined in the Companies Act. The Bank Guarantee format for Security Deposit shall be in the prescribed formats enclosed with general conditions of contract.
- iv) Fixed Deposit Receipt issued by Scheduled Banks / Public Financial Institutions as defined in the Companies Act. The FDR should be in the name of the contractor, A/C BHEL and duly discharged on the back.
- v) Securities available from Indian Post Offices such as National Savings Certificates, Kisan Vikas Patras etc. (Certificates should be held in the name of Contractor furnishing the security and duly endorsed/hypothecated/pledged, as applicable, in favour of BHEL and duly discharged on the back).
- vi) Insurance Surety Bonds

**(NOTE: BHEL will not be liable or responsible in any manner for the collection of interest or renewal of the documents or in any other matter connected therewith)**

### **11.2 Submission of Security Deposit:**

- i) At least 50 % of the required Security Deposit, shall be submitted before start of work. Balance of the Security Deposit can be submitted by way of deduction of 10% of the gross amount progressively from each running bills of the contractor till the total amount of the required Security Deposit is collected.
- ii) In case of delay in submission of performance security, enhanced performance security which would include interest (Repo rate + 4%) for the delayed period, shall be submitted by the bidder.
- iii) If the value of work done at any time exceeds the contract value, the amount of Security Deposit shall be correspondingly enhanced and the additional Security Deposit shall be immediately deposited by the Contractor or it shall be recovered from payment/s due to the Contractor.
- iv) The recoveries made from running bills (cash deduction towards balance SD amount) can be released against submission of equivalent Bank Guarantee in acceptable form, but only once, before completion of work, at the discretion of BHEL.

**11.3** The BG shall be submitted only through the Banker. Along with the BG, the Bank shall also furnish a letter of confirmation

**11.4** The validity of the Bank Guarantee furnished towards Security Deposit shall be up to three months more than the period of completion of work as stipulated in the LOI and the same will be kept valid by proper renewal till the completion of the work.

**11.5** BHEL reserves the right of forfeiture of Security Deposit in addition to other claims and penalties in the event of the contractor's failure to fulfil any of the contractual obligations or in the event of termination of contract as per terms and conditions of the contract. BHEL reserves the right to set off the Security Deposit, against any claims of any other contracts with BHEL.

### **11.6 Conditions for acceptance of bank guarantees**

Contractors are advised to obtain Bank Guarantee preferably from any of the following BHEL consortium banks

Bank Guarantees from Banks outside BHEL's consortium shall be as below:



# BHARAT HEAVY ELECTRICALS LIMITED

TRANSMISSION BUSINESS GROUP

(Subcontract Management)

PLOT NO.- 25, SECTOR-16A, NOIDA-201301

Tender Spec. no.: TBSM/LARA/SURVEY/TENDER/24-25

Date: 09.05.2024

Sl. No.	Name of Bank	Sl. No.	Name of Bank
1	State Bank of India	11	Punjab National Bank
2	Canara Bank	12	Union Bank of India
3	IDBI Bank Limited	13	Yes Bank Limited
4	ICICI Bank Limited	14	RBL Bank Ltd.
5	HDFC Bank Limited	15	Standard Chartered Bank
6	Axis Bank	16	Indian Overseas Bank
7	IndusInd Bank Limited	17	Kotak Mahindra Bank Limited
8	Bank of Baroda	18	Federal Bank Limited
9	Exim Bank	19	Hongkong and Shanghai Banking Corporation Ltd
10	Indian Bank		

The Bank Guarantees of all Public sector banks can be accepted (in addition to consortium banks)

**The Bank Guarantees of Co-operative banks shall not be accepted.**

Bank Guarantees of other than consortium bank and public sector bank can be accepted subject to an overall exposure limit (at New Delhi) of Rs. 10 crores for banks with network of more than Rs. 500 crores as on last balance sheet date and Rs 5 crores for banks with net worth between Rs. 350 to Rs 500 crores (A certificate and copy of latest Balance Sheet to be given by the Bank at the time of submission of Bank Guarantees).

In case of private sector banks a clause to be incorporated in the text of Bank Guarantee that it can be enforceable by being presented at any branch of the bank.

In case of foreign vendors the bank guarantees issued by foreign banks may be confirmed by our consortium bank in India.

**In case of Bank Guarantees given by Non-Consortium banks (Private sector or Public sector), the Bank Guarantees are to be enforceable in New Delhi or the town/ city in which the sector office is located.**

## 11.7 RETURN OF SECURITY DEPOSIT:

If the contractor duly performs and completes the work in all respects to the entire satisfaction of BHEL and presents an absolute "No demand certificate", returns properties belonging to BHEL, taken, borrowed or hired by him for carrying out the said works, and furnishes performance bond BG in the prescribed proforma, Security Deposit will be released to the contractor after deducting all costs, expenses and other amounts that are to be paid to BHEL under this contract or other contracts entered into with the contractor.

**It may be noted that in no case the Security Deposit shall be refunded/released prior to passing of final bill**



# BHARAT HEAVY ELECTRICALS LIMITED

TRANSMISSION BUSINESS GROUP

(Subcontract Management)

PLOT NO.- 25, SECTOR-16A, NOIDA-201301

Tender Spec. no.: TBSM/LARA/SURVEY/TENDER/24-25

Date: 09.05.2024

**11.8 Bank Account Details for submission of EMD/ Security Deposit through electronic fund transfer mode.**

NAME OF THE COMPANY	BHARAT HEAVY ELECTRICALS LTD
ADDRESS OF THE COMPANY	TRANSMISSION BUSINESS GROUP, PLOT NO. -25, SECTOR-16A, NOIDA DISTT.- GAUTAMBUDH NAGAR – 201301 (U.P.)
NAME OF BANK	STATE BANK OF INDIA
NAME OF BANK BRANCH	CAG-II NEW DELHI (17313)
CITY	NEW DELHI
ACCOUNT NUMBER	00000030206227732
ACCOUNT TYPE	CASH CREDIT
IFSC CODE	SBIN0017313

**12.0 PAYMENT TERMS:**

Sr. No.	Condition	Payment
1.	After conducting survey work, report preparation, Submission and approval of reports/design documents/ drawings (i) Cat 2 i.e. Approved with comments (ii) Cat 1 i.e. Approved	i) 80% ii) 10%
2.	After completion of activities under scope of works including check survey and BOM, approval of all Drawings/Documents in Cat-1, submission of all drawings/documents.	Balance 10%

**13.0 QUANTITY AND PRICE VARIATION**

The individual quantity can vary to any extent or may be deleted for which no compensation will be payable to the contractor and the rates will remain firm. Also, the rate of each item remains firm as long as the variation in the total value of work executed under the contract including extra items (if any) remains within plus/minus 30 percent of the contract value. In case the actual value of executed work including extra work on completion of work becomes less than 70% of the basic/original contract value than the following method shall be adopted.

The actual executed value shall be raised by 7% (For arriving at the final payment against work executed) subject to the condition that total value of work executed plus increase by 7% as above shall be limited to 70% of the basic/original contract value. The rate quoted shall be firm irrespective of any upward variation in the contract price.

**14.0 TAXES & DUTIES: -**

14.1 All taxes (except GST), duties, charges, royalties, cess and any other levies by Central/ State/local authorities for the execution of the contract shall be borne by the contractor and shall not be payable extra. Any increase of the same at any stage during execution of the contract shall be borne by the contractor. Quoted price of the same shall be inclusive of all such requirements.

14.2 Contractors have to make their own arrangement at their cost for completing the formalities, if required with relevant taxation authorities, for bringing their material, plant and machinery at



# BHARAT HEAVY ELECTRICALS LIMITED

## TRANSMISSION BUSINESS GROUP

(Subcontract Management)

PLOT NO.- 25, SECTOR-16A, NOIDA-201301

**Tender Spec. no.: TBSM/LARA/SURVEY/TENDER/24-25**

**Date: 09.05.2024**

site for the execution of the contract. Road permits / way bill, if required shall be arranged by the contractor.

14.3 The Contractor is responsible to furnish documentary evidence towards GST Registration of the State wherein the site is located or any other documents as per GST Act which may be required from time to time. BHEL will not be held to be responsible for any non-compliance of the Contractor in respect of GST laws as framed from time to time.

14.4 Goods and Service Tax (GST) will be reimbursed to the Contractor subject to the following conditions: -

- a. Submission of valid GST Compliant Tax Invoice as per the GST Invoice Rules.
- b. The Invoice raised by the Contractor should indicate the BHEL GST Registration Number.
- c. Contractor declaring such invoice in GSTR-1.
- d. Confirmation of payment of GST thereon by contractor on GST portal.

14.5 The GST amount shall get reflected within prescribed time limit in the GSTN for BHEL to avail the input credit. If the GST Credit is reversed/ denied/ delayed to BHEL due to non-receipt/delayed receipt of Services and/or tax invoice or due to expiry of timeline prescribed in GST law or due to any other factor for availing such Input Tax Credit (ITC) or for any other reason arising out of the act directly attributable to the Contractor, GST amount shall be recoverable from Contractor from any dues payable to the Contractor along with any interest levied/ leviable on BHEL.

14.6 Statutory variation, if any, on account of GST will be payable by BHEL at actuals on submission of documentary evidence.

14.7 TDS under Income Tax Act/ GST Act shall be deducted as per applicable rates unless Exemption certificate, if applicable, from the appropriate Authority is furnished to BHEL along with the Invoice.

**14.8 New Taxes & duties (Introduced after tender opening date):**

If any new tax or duty is levied by the Authority and becomes directly applicable on items specified in the Bill of Quantities, full reimbursement shall be made subject to submission of documentation as per statute.

### **15.0 COMPLETION SCHEDULE:**

The work under this scope of work must be completed within **03 months** after placement of order except check survey.

The check survey shall be done along with civil construction agency after finalizing coordination with of civil construction agency by BHEL and intimation by site in-charge. Check survey should be completed within **2 Weeks** including submission of Check survey report.

### **16.0 RESPONSIBILITY OF CONTRACTOR IN RESPECT OF STATUTORY RULES / REGULATIONS PERTAINING TO BOCW.**

It shall be mandatory for the contractor to comply with Building and Other Construction Worker (Regulation of Employment and Conditions of Service) Act, 1996 and Rules of 1998 read with Building and other Construction Workers welfare Cess act, 1996 and Cess Rules.

It shall be the sole responsibility of the contractor to apply for a license to the Competent Authority under the Building and Other Construction Worker (Regulation of



# BHARAT HEAVY ELECTRICALS LIMITED

TRANSMISSION BUSINESS GROUP

(Subcontract Management)

PLOT NO.- 25, SECTOR-16A, NOIDA-201301

**Tender Spec. no.: TBSM/LARA/SURVEY/TENDER/24-25**

**Date: 09.05.2024**

Employment and Conditions of Service) Act, 1996 and Rules of 1998 read with Building and other Construction Workers welfare Cess act, 1996 and Cess Rules and obtain proper certificate thereof by specifying the scope of its work. It shall also be responsibility of the contractor to furnish a copy of such certificate of license / permission to BHEL within 2 months from date of start of work at site or along with 1st RA bill whichever is earlier.

It shall be the responsibility of the sub-contractor to furnish the receipts / challans towards deposit of the cess together with the number, name and other details of beneficiaries (building or construction workers) engaged by the sub-contractor during the preceding month.

The onus shall lie on the contractor to register with the authorities and provide the details of the amount remitted to the authorities. In case the contractor fails to comply with the BOCW act, no payments shall be released to the contractor.

In case the customer owns the responsibility of compliance of BOCW act and deducts the amount from BHEL, the same shall be deducted from the RA bills of the contractor. In the event of any penalty or other implication due to non-compliance of statutory obligation the same shall be on contractor's account.

**17.0 LIQUIDATED DAMAGE/PENALTY:**

In case the contractor fails to complete the project within the time specified in the tender specification or any extension thereof subject to force majeure condition, the contractor shall be liable to pay by way of LD/Penalty a sum equal to the half percent of the contract price, per calendar week or part thereof by which the commissioning of the project is delayed, subject to ceiling of 10 % of the contract price. Once the maximum limit of delay is reached (i.e. 20 week of delay) BHEL may consider termination of the contract and forfeit the Security deposit without prejudice to the other remedies under the contract.

Amended/ revised contract value (excluding ORC, Extra Works, Supplementary /Additional Items and PVC) shall be considered for calculating LD/ penalty.

**18.0 VALIDITY OF OFFER**

The offer shall be kept open for acceptance for a minimum period of FOUR months from the date of opening of tenders. In case BHEL calls for negotiations, such negotiations shall not amount to cancellation or withdrawal of the original offer which shall be binding on the tenderer.

**19.0 LD/PENALTY FOR DELAY IN COMPLETION: -**

In case the contractor fails to complete the project within the time specified in the tender specification or any extension thereof subject to force majeure condition, the contractor shall be liable to pay by way of LD/Penalty a sum equal to the half percent of the contract price, per calendar week or part thereof by which the commissioning of the project is delayed, subject to ceiling of 10 % of the contract price. Once the maximum limit of delay is reached (i.e. 20 week of delay) BHEL may consider termination of the contract and forfeit the Security deposit without prejudice to the other remedies under the contract.

Amended/ revised contract value (excluding ORC, Extra Works, Supplementary /Additional Items and PVC) shall be considered for calculating LD/ penalty.

**20.0 DELAY AND EXTENSION OF TIME:**

If, in the opinion of the Engineer, the work is delayed

- (i) by reason of civil commotion, local combination of workmen, strike or lockout, affecting any of the trades employed on the work, or



# BHARAT HEAVY ELECTRICALS LIMITED

TRANSMISSION BUSINESS GROUP

(Subcontract Management)

PLOT NO.- 25, SECTOR-16A, NOIDA-201301

**Tender Spec. no.: TBSM/LARA/SURVEY/TENDER/24-25**

**Date: 09.05.2024**

- (ii) by reason of abnormally bad weather, or
- (iii) by reason of serious loss or damage by fire, or
- (iv) by delay on the part of the agency or tradesman engaged by the BHEL in executing work not forming part of the contract, or
- (v) By reason of any other cause which in the absolute discretion of the Engineer is beyond the contractor's control, then in any such case, the Engineer (or higher authority) may make fair and reasonable extension in the completion dates of the individual items of work of the contract as whole. Such extension which will be communicated to the contractor by the Engineer in writing shall be final and binding on the contractor.
- (vi) In case of delay in completion of work BHEL reserve the right to grant time extension under the following options depending upon the performance of the vendor:
  - 20.1 Time extension without levy of LD in case it is found that delay is not attributable to the vendor.
  - 20.2 Time extension with deduction of applicable LD in line with Liquidity Damage clause if the delay is solely attributable to the vendor.
  - 20.3 In case facts of delay is not settled, BHEL reserve the right to grant provisional time extension for delay in completion of total work or part thereof and running/ interim payments to the vendor will be released without deduction of LD subject to submission of additional Bank guarantee equivalent to maximum LD amount valid till completion of work under their scope and grant of final time extension.

BHEL reserves to itself the following rights without entitling the Vendor for any compensation

## **21.0 RIGHTS OF BHEL**

BHEL reserves the following rights in respect of this contract during the original contract period or its extensions if any, as per the provisions of the contract, without entitling the contractor for any compensation.

- 21.1 To withdraw any portion of work and/or to restrict/alter quantum of work as indicated in the contract during the progress of work and get it done through other agencies to suit BHEL's commitment to its customer or in case BHEL decides to advance the date of completion due to other emergent reasons/ BHEL's obligation to its customer.

In case of inadequate manpower deployed by the contractor, BHEL reserves the right to deploy additional manpower through any other agency for expediting activities in the interest of the project.

Supplied manpower shall be put on job by the contractor and payments and other statutory compliances related to manpower shall be the contractor's responsibility. In case of contractor's failure to fulfill his obligations in respect of such manpower, BHEL reserves the right to take necessary action as per contract conditions.

## **21.2 Breach of Contract, Remedies and Termination: -**

- 21.2.1 BHEL shall terminate the contract after due notice of a period of 14 days' in any of the following cases, which if not rectified/ improved within the time period mentioned in the notice, then, 'Breach of Contract' will be considered to have been established:



# BHARAT HEAVY ELECTRICALS LIMITED

TRANSMISSION BUSINESS GROUP

(Subcontract Management)

PLOT NO.- 25, SECTOR-16A, NOIDA-201301

**Tender Spec. no.: TBSM/LARA/SURVEY/TENDER/24-25**

**Date: 09.05.2024**

- i) Contractor's poor progress of the work vis-à-vis execution timeline as stipulated in the Contract, backlog attributable to contractor including unexecuted portion of work does not appear to be executable within balance available period considering its performance of execution.
- ii) Withdrawal from or abandonment of the work by contractor before completion of the work as per contract.
- iii) Non-completion of work by the Contractor within scheduled completion period as per Contract or as extended from time to time, for the reasons attributable to the contractor.
- iv) Repeated failure of contractor in deploying the required resources, to comply the statutory requirements etc. even after given by BHEL in writing.
- v) Strike or Lockout declared is not settled within a period of one month.
- vi) Termination of Contract on account of any other reason (s) attributable to Contractor.
- vii) Assignment, transfer, subletting of Contract without BHEL's written permission.
- viii) Non-compliance to any contractual condition or any other default attributable to Contractor.

### **LD against delay in executed work in case of Termination of Contract:**

LD against delay in executed work shall be calculated in line with LD clause no. 19.0 of GCC, for the delay attributable to contractor. For limiting the maximum value of LD, contract value shall be taken as Executed Value of work till termination of contract. Method for calculation of "LD against delay in executed work in case of termination of contract" is given below.

- i) Let the time period from scheduled date of start of work till termination of contract excluding the period of Hold (if any) not attributable to contractor = T1
- ii) Let the value of executed work till the time of termination of contract = X
- iii) Let the Total Executable Value of work for which inputs/fronts were made available to contractor and were planned for execution till termination of contract = Y
- iv) Delay in executed work attributable to contractor i.e.  $T2 = [1 - (X/Y)] \times T1$
- v) LD shall be calculated in line with LD clause (clause no. 19.0) of the Contract for the delay attributable to contractor taking "X" as Contract Value and "T2" as period of delay attributable to contractor.

### **21.2.2 Remedies in case of Breach of Contract is established:**

In case 'Breach of Contract' is established, Security Deposit and Retention Amount shall be encashed/ forfeited. This is without prejudice to BHEL's right to levy of liquidated damages, debarment etc. which shall be applied as per the provisions of the contract. Sequence of recovery to be made in case of breach of contract is established, is as below:

- (a) In case the value of Security Deposit & Retention Amount, available for the Contract, is less than 10% of the Contract Value, the balance amount shall be recovered from dues available in the form of Bills payable to contractor against the same contract etc.



# BHARAT HEAVY ELECTRICALS LIMITED

TRANSMISSION BUSINESS GROUP

(Subcontract Management)

PLOT NO.- 25, SECTOR-16A, NOIDA-201301

**Tender Spec. no.: TBSM/LARA/SURVEY/TENDER/24-25**

**Date: 09.05.2024**

- (b) Demand notice for deposit of balance recovery amount shall be sent to contractor, if funds are insufficient to effect complete recovery against dues indicated in (a) above.
- (c) If contractor fails to deposit the balance amount to be recovered within the period as prescribed in demand notice, following action shall be taken for balance recovery:
  - i) Dues payable to contractor against other contracts in the same Region shall be considered for recovery.
  - ii) If recovery cannot be made out of dues payable to the contractor as above, balance amount to be recovered, shall be informed to other Regions/Units for making recovery from the Unpaid Bills/Running Bills/SD/BGs/Final Bills of contractor.
  - iii) In-case recoveries are not possible with any of the above available options, Legal action shall be initiated for recovery against contractor.

**Note:**

- 1) In addition to above, levy of liquidated damages, debarment, termination, short-closure etc. shall be applied as per provisions of the contract.
  - 2) If tendering is done for the balance work, the defaulted contractor shall not be eligible for either executing the balance work or to participate in the tender(s) for executing the balance work. Defaulted Contractor will include:
    - (a) In case defaulted contractor is The Sole Proprietorship Firm, any Sole Proprietorship Firm owned by same Sole Proprietor.
    - (b) In case defaulted contractor is The Partnership Firm, any firm comprising of same partners/ some of the same partners (but not including any new partner); or sole proprietorship firm owned by any partner(s) as a sole proprietor.
- 21.2.3 .In case Contractor fails to deploy the resources as per requirement informed by BHEL in writing to expedite the work, BHEL can deploy own/hired/otherwise arranged resources and recover the expenses incurred from the dues payable to contractor. Recoveries shall be actual expenses incurred plus 5% overheads or as defined in TCC.
- 21.2.4 To terminate the contract or to restrict the quantum of work and pay for the portion of work executed in case BHEL's contract with their customer are terminated for any reason, as per mutual agreement.
- 21.2.5 To effect recovery from any amounts due to the contractor under this or any other contract or in any other form, the moneys BHEL is statutorily forced to pay to anybody, due to contractor's failure to fulfill any of his obligations. BHEL shall levy overheads of 5% on all such payments along with interest as defined elsewhere in the GCC.
- 21.2.6 While every endeavor will be made by BHEL to this end, they (BHEL) cannot guarantee uninterrupted work due to conditions beyond their control. The Contractor will not be normally entitled for any compensation/extra payment on this account unless otherwise specified elsewhere in the contract.



# BHARAT HEAVY ELECTRICALS LIMITED

TRANSMISSION BUSINESS GROUP

(Subcontract Management)

PLOT NO.- 25, SECTOR-16A, NOIDA-201301

**Tender Spec. no.: TBSM/LARA/SURVEY/TENDER/24-25**

**Date: 09.05.2024**

21.2.7 BHEL may permit or direct contractor to demobilize and remobilize at a future date as intimated by BHEL in case of following situations for reasons other than Force majeure conditions and not attributable to contractor:

- i) suspension of work(s) at a Project either by BHEL or Customer,
- or
- ii) where work comes to a complete halt or reaches a stage wherein worthwhile works cannot be executed and there is no possibility of commencement of work for a period of not less than three months

In such cases, charges towards demobilization and remobilization shall be as decided by BHEL after successful remobilization by contractor at site, and decision of BHEL shall be final and binding on the contractor. After remobilization, all conditions as per contract shall become applicable. In case Contractor does not remobilize with adequate resources or does not start the work within the period as intimated, then BHEL reserves the right to terminate the contract and effect remedies under Clause 2.2.2. In case of any conflict, BHEL decision in this regard shall be final and binding on the contractor.

21.2.8 In the unforeseen event of inordinate delay in receipt of materials, drawings, fronts etc. due to which inordinate discontinuity of work is anticipated, BHEL on its own or contractor's request at its discretion may consider to short close the contract in any of the following cases:

- a) The balance works (including but not limited to Trial Operation, PG Test etc.) are minor vis a vis the scope of work envisaged as per the contract.
- b) here has been no significant work in past 6 months OR no significant work is expected in next 6 months (example in Hydro projects or in projects where work has stopped due to reasons beyond the control of BHEL).
- c) The balance works cannot be done within a reasonable period of time as they are dependent on unit shut down or on other facilities of customer or any other such reasons not attributable to the contractor.

At the point of requesting for short closure, contractor shall establish that he has completed all works possible of completion and he is not able to proceed with the balance works due to constraints beyond his control. In such a case, the estimated value of the unexecuted portion of work (or estimated value of services to be provided for carrying out milestone/stage payments like Trial Operation/PG Test etc.) as decided by BHEL, shall however be reduced from the final contract value.

Note: The Contractor shall not be eligible for any compensation on account of Quantity Variation arising out of short-closure of contract as per clause no. 2.8 (b) above.

## **22.0 MEASUREMENT OF WORK AND MODE OF PAYMENT:**

- i. All payments due to the contractors shall be made by e mode only, unless otherwise found operationally difficult for reasons to be recorded in writing.
- ii. For progress running bill payments: - The Contractor shall present detailed measurement sheets in triplicate, duly indicating all relevant details for work done during the month/period under various categories in line with terms of payment as per contract. These measurement sheets shall be prepared jointly with BHEL Engineers and signed by both the parties.
- iii. These measurement sheets will be checked by BHEL Engineer and quantities and percentage eligible for payment under various groups shall be decided by BHEL Engineer. The abstract of quantities and percentage so arrived at based on the terms of payment shall be entered in Measurement Book by BHEL Engineers and signed by both the parties.



# BHARAT HEAVY ELECTRICALS LIMITED

TRANSMISSION BUSINESS GROUP

(Subcontract Management)

PLOT NO.- 25, SECTOR-16A, NOIDA-201301

**Tender Spec. no.: TBSM/LARA/SURVEY/TENDER/24-25**

**Date: 09.05.2024**

- iv. Based on the above quantities, contractor shall prepare the bills, along with statutory documents, in prescribed format and work out the financial value. These will be entered in Measurement Book and signed by both the parties. Payment shall be made by BHEL after effecting the recoveries due from the contractor.
- v. All recoveries due from the contractor for the month/period shall be effected in full from the corresponding running bills unless specific approval from the competent authorities is obtained to the contrary.
- vi. Measurement shall be restricted to that portion of work for which it is required to ascertain the financial liability of BHEL under this contract.
- vii. The measurement shall be taken jointly by persons duly authorized on the part of BHEL and by the Contractor.
- viii. The Contractor shall bear the expenditure involved if any, in making the measurements of the work. The contractor shall, without extra charges, provide all the assistance with appliances and other things necessary for measurement.
- ix. If at any time due to any reason whatsoever, it becomes necessary to re-measure the work done in full or in part, the expenses towards such re measurements shall be borne by the contractor unless such re measurements are warranted solely for reasons not attributable to contractor.
- x. Passing of bills covered by such measurements does not amount to acceptance of the completion of the work measured. Any left out work has to be completed, if pointed out at a later date by BHEL.
- xi. Final measurement bill shall be prepared in the final bill format prescribed for the purpose based on the certificate issued by BHEL Engineer that entire works as stipulated in tender specification has been completed in all respects to the entire satisfaction of BHEL. Contractor shall give unqualified "No Claim" Certificate. All the tools and tackles loaned to him should be returned in satisfactory condition to BHEL. The abstract of final quantities and financial values shall also be entered in the Measurement Books and signed by both parties to the contract. The Final Bill shall be prepared and paid within a reasonable time after completion of work

## **23.0 NO INTEREST PAYABLE TO CONTRACTOR:**

Notwithstanding anything to the contrary contained in any other document comprising in the Contract, no interest shall be payable by BHEL to Contractor on any moneys or balances including but not limited to the Security Deposit, EMD, Retention Money, RA Bills or the Final Bill, or any amount withheld and/or appropriated by BHEL etc., which becomes or as the case may be, is adjudged to be due from BHEL to Contractor whether under the Contract or otherwise.

## **24.0 PROGRESSIVE PAYMENT/ FINAL PAYMENT:**

### **24.1 Running Account Bills (RA Bills)**

- i) These are for interim payments when the contracts are in progress. The bills for such interim payments are to be prepared by Contractor in prescribed formats (RA Bill forms).
- ii) Payments shall be made according to the extent of work done as per measurements taken up to the end of the calendar month and in line with the terms of payments described in the Tender documents.
- iii) Recoveries on account of electricity, water, statutory deductions etc. are made as per terms of contract.



# BHARAT HEAVY ELECTRICALS LIMITED

## TRANSMISSION BUSINESS GROUP

### (Subcontract Management)

PLOT NO.- 25, SECTOR-16A, NOIDA-201301

**Tender Spec. no.: TBSM/LARA/SURVEY/TENDER/24-25**

**Date: 09.05.2024**

- iv) Full rates for the work done shall be allowed only if the quantum of work has been done as per the specifications stipulated in the contract. If the work is not executed as per the stipulated specifications, BHEL may ask the contractor to redo the work according to the required specifications, without any extra cost.
- v) The contractor shall submit his monthly RA bills with all the details required by BHEL on specified date every month covering progress of work in all respects and areas for the previous calendar month.
- vi) Mode of payment and measurement of work completed shall be as per relevant clauses of General Conditions of Contract
- vii) Release of payment in each running bill including PVC Bills where ever applicable will be as per stages of progressive pro rata payments.
- viii) The contractor will be eligible for payment of RA Bills within 30 days of submission of running bill complete in all respects with all documents. It is the responsibility of the contractor to make his own arrangements for making timely payments towards labour wages, statutory payments, outstanding dues etc. and other dues in the meanwhile.  
All documents like HR Clearance, Quality and Safety Compliances etc. required for processing the RA Bills should be submitted along with RA Bills.
- ix) BHEL shall release payment through Electronic Fund Transfer (EFT)/RTGS. In order to implement this system, Contractor to furnish details pertaining to his Bank Accounts where proceeds will be transferred through BHEL's banker, as per prescribed formats.  
Note: BHEL may also choose to release payment by other alternative modes as applicable

#### **24.2 Documents required for RA Bill:**

- a) GST Complied Invoice of the work done as per approved BOQ.
- b) Jointly signed Measurement sheet, Abstract, WAM -6 for RA Bill.
- c) Power of Attorney before submission of Bill.
- d) Validity of Bank Guarantees as applicable under the contract.
- e) HR compliance documents:
  - i) Labour Payment Certificate, Wages payment sheet
  - ii) Proof of PF, ESI, WC contribution submission
  - iii) Proof of Bonus payment as per Bonus Act if applicable.
- f) Any other documents as per customer requirement/statutory requirement.

#### **24.3 Final Bill:**

Final Bill' is used for final payment on closing of Running Account for works or for single payment after completion of works. 'Final Bill' shall be submitted as per prescribed format after completion of works as per scope, material reconciliation, removal of temporary structures, return of scrap/surplus material of BHEL. BHEL shall settle the final bills after deducting all liabilities of Contractor to BHEL.

##### **24.3.1 Documents required for Final Bill:**

- a. GST Complied Invoice of the work done as per approved BOQ
- b. Jointly signed Measurement sheet, Abstract, WAM -7 format.
- c. Submission of and approval of reports/design documents/ drawings of Cat 1 i.e. Approved
- d. 'No claim' certificate from the contractor.
- e. HR compliance documents: - 1) Proof of PF, ESI, WC contribution submission; 2) Proof of Bonus payment as per Bonus Act if applicable; 3) Labour Payment Certificate, Wages payment sheet
- f. Deviation statement showing the Executed quantities and quantities as per the contract.



# BHARAT HEAVY ELECTRICALS LIMITED

TRANSMISSION BUSINESS GROUP

(Subcontract Management)

PLOT NO.- 25, SECTOR-16A, NOIDA-201301

**Tender Spec. no.: TBSM/LARA/SURVEY/TENDER/24-25**

**Date: 09.05.2024**

- g. Final Delay Analysis.
- h. Any other documents as per customer requirement/statutory requirement.

## **25.0 LAW GOVERNING THE CONTRACT AND COURT JURISDICTION:**

The Contract shall be governed by the Law for the time being enforced in the Republic of India. The Civil Court at Delhi having ordinary Original Civil Jurisdiction shall alone have exclusive jurisdiction in regard to all claims in respect of this contract.

## **26.0 FORCE MAJEURE:**

The following shall amount to force majeure conditions:

- 26.1 Acts of God, Act of any Government, war, sabotage, riots, civil commotion, Police action, revolution, flood, fire cyclone, earthquake, epidemic and other similar causes over which the vendor has no control.
- 26.2 If the vendor suffers delay in the due execution of the contract, due to delays caused by force majeure conditions, as defined above, the agreed time of completion of the work covered by this contract may be extended by a reasonable period of time in consultation and after agreement of BHEL's clients/owner, provided that on the occurrence of any such contingency, the Vendor immediately reports to BHEL in writing the causes of delay. The Vendor shall not be eligible for any compensation on this account.

## **27.0 Model Conciliation Clause for Conducting Conciliation Proceedings Under the BHEL Conciliation Scheme, 2018**

The Parties the if at any time (whether before, during or after the arbitral or judicial proceedings), any Disputes (which terms shall means and include any dispute, difference, question or disagreement arising in connection with construction, meaning, operation, effect, interpretation or breach of the agreement, contract or the Memorandum of Understanding (delete whichever is inapplicable), which the parties unable to settle mutually), arise inter-se the Parties, the same may, be refereed by either party to conciliation to be conducted through Independent Experts Committee to be appointed by competent authority of BHEL from the BHEL Panel of Conciliators.

Notes:

- 1. No serving or a retired employee of BHEL/Administrative Ministry of BHEL shall be included in the BHEL Panel of Conciliators.
- 2. Any other person(s) can be appointed as Conciliator(s) who is/are mutually agreeable to both the parties from outside the BHEL Panel of Conciliators.

The proceedings of Conciliation shall broadly be governed by Part-III of the Arbitration and Conciliation Act 1996 or any statutory modification thereof and as provided in Annexure-A.

The Annexure-A together with its appendices will be treated as if the same is part and parcel hereof and shall be as effectual as if set out herein in these GCC."

## **28.0 ARBITRATION**

(i) Except as provide elsewhere in this Contract, in case amicable settlement is not reached between the Parties, in respect of any dispute or difference; arising out of the formation, breach, termination, validity or execution of the contract; or, the respective rights and liabilities of the Parties; or, in relation to interpretation of any provision of the contract; or, in relation to interpretation of any provision of the Contract; or, in any manner touching upon the contract, then, either Party may, by a notice in writing to the other Party refer such dispute or



# BHARAT HEAVY ELECTRICALS LIMITED

TRANSMISSION BUSINESS GROUP

(Subcontract Management)

PLOT NO.- 25, SECTOR-16A, NOIDA-201301

**Tender Spec. no.: TBSM/LARA/SURVEY/TENDER/24-25**

**Date: 09.05.2024**

difference to the sole arbitration of an arbitrator appointed by Head of the BHEL Unit/Region/Division issuing the Contract.

The Arbitrator shall pass a reasoned award and the award of the Arbitrator shall be final and binding upon the Parties.

Subject as aforesaid, the provisions of Arbitration and Conciliation Act 1996 (India) or statutory modifications or re-enactments thereof and the rules made thereunder and for the time being in force shall apply to the arbitration proceedings under this clause. The seat of arbitration shall be New Delhi.

The cost of arbitration shall be borne as per the award of the Arbitrator.

Subject to the arbitration in terms of clause L above, the court at New Delhi shall have exclusive jurisdiction over any matter arising out of or in connection with this Contract.

Notwithstanding the existence or any dispute or differences and/or reference for the arbitration, the Contractor shall proceed with and continue without hindrance the performance of its obligations under this contract with due diligence and expedition in a professional manner except where the contract has been terminated by either Party in terms of this contract.

(ii) In the event of dispute or difference relating to the interpretation and application of the provisions of commercial contract(s) between Central Public Sector Enterprises (CPSEs)/ Port Trusts inter se and also between CPSEs and Government Departments/Organizations (excluding disputes concerning Railways, Income Tax, Customs & Excise Departments), such dispute or difference shall be taken up by either party for resolution through AMRCD as mentioned in DPE OM No.4(1)/2013-DPE9GM)/FTS-1835 dated 22.05.2018.

## **29.0 PERFORMANCE MONITORING:**

The Contractors performance shall be continuously monitored during execution of work at site.

In case of contractor's performance is found not satisfactory during the execution of work at site, BHEL may take alternate remedial measures and may not consider the contractor for further tenders, if the contractor performance is not improved in spite of opportunities given by BHEL.

**PROFORMA OF BANK GUARANTEE (in lieu of SECURITY DEPOSIT)**

In consideration of Bharat Heavy Electricals Limited (hereinafter referred to as the 'Employer' which expression shall unless repugnant to the context or meaning thereof, include its successors and permitted assigns) incorporated under the Companies Act, 1956 and having its registered office at BHEL House, Siri Fort, New Delhi-110049 through its Unit at BHEL, Transmission Business Group, Noida (name of the Unit) having agreed to exempt \_\_\_\_\_ (Name of the Vendor / Contractor / Supplier) with its registered office at \_\_\_\_\_<sup>1</sup> (hereinafter called the said "Contractor" which term includes supplier), from demand under the terms and conditions of the Contract reference No. \_\_\_\_\_ dated \_\_\_\_\_<sup>2</sup> valued at Rs. ....<sup>3</sup> ( Rupees ..... ) (hereinafter called the said Contract), of Security Deposit for the due fulfilment by the said Contractor of the terms and conditions contained in the said Contract, on production of a Bank Guarantee for Rs. ....<sup>4</sup> (Rupees.....only),

We \_\_\_\_\_ (indicate the name and address of the Bank) having its Head Office at \_\_\_\_\_ (address of the head Office) (hereinafter referred to as the Bank), at the request of \_\_\_\_\_ [Contractor(s)], being the Guarantor under this Guarantee, do hereby irrevocably and unconditionally undertake to forthwith and immediately pay to the Employer, an amount not exceeding Rs. \_\_\_\_\_ without any demur, immediately on demand from the Employer and without any reservation, protest, and recourse and without the Employer needing to prove or demonstrate reasons for its such demand

Any such demand made on the bank, shall be conclusive as regards the amount due and payable by the Bank under this guarantee. However, our liability under this guarantee shall be restricted to an amount not exceeding Rs. \_\_\_\_\_.

We undertake to pay to the Employer any money so demanded notwithstanding any dispute or disputes raised by the Contractor(s) in any suit or proceeding pending before any Court or Tribunal or Arbitrator or any other authority, our liability under this present being absolute and unequivocal.

The payment so made by us under this guarantee shall be a valid discharge of our liability for payment hereunder and the Contractor(s) shall have no claim against us for making such payment.

We, further agree that the guarantee herein contained shall remain in full force and effect during the period that would be taken for the performance of the said Contract and that it shall continue to be enforceable till all the dues of the Employer under or by virtue of the said Contract have been fully paid and its claims satisfied & the Employer certifies that the terms and conditions of the said Contract have been fully and properly carried out by the said contractor(s) or acceptance of the final bill or discharge of this guarantee by the Employer, whichever is earlier. This guarantee shall initially remain in force up to and including \_\_\_\_\_<sup>5</sup> and shall be extended from time to time for such period as may be desired by the Employer. Unless a demand or claim under this guarantee is made on us in writing on or before the \_\_\_\_\_<sup>6</sup>, (3 months more than the present date of validity of Bank Guarantee) we shall be discharged from all the liability under this guarantee thereafter.

We, \_\_\_\_\_ (indicate the name of the Bank) further agree with the Employer that the Employer shall have the fullest liberty without our consent and without affecting in any manner our obligations hereunder to vary any of the terms and conditions of the said Contract or to extend time of performance by the said contractor(s) from time to time or to postpone for any time or from time to time any of the powers exercisable by the Employer against the said contractor(s) and to forbear or enforce any of the terms and conditions relating to the said

Contract and we shall not be relieved from our liability by any reason of any such variation or extension being granted to the said contractor(s) or for any forbearance, act or omission on the part of the Employer or any indulgence by the Employer to the said contractor(s) or by any such matter or thing whatsoever which under the law relating to sureties would but for this provision have effect of so relieving us.

The Bank also agrees that the Employer at its option shall be entitled to enforce this Guarantee against the Bank as a principal debtor, in the first instance without proceeding against the Contractor and notwithstanding any security or other guarantee that the Employer may have in relation to the Contractor's liabilities.

This Guarantee shall not be determined or affected by liquidation or winding up, dissolution or change of constitution or insolvency of the Contractor but shall in all respects and for all purposes be binding and operative until payment of all money payable to the Employer in terms thereof. This guarantee will not be discharged due to the change in the constitution of the Bank or the Contractor(s).

We,..... BANK lastly undertake not to revoke this guarantee during its currency except with the previous consent of the Employer in writing.

Notwithstanding anything to the contrary contained hereinabove:

- a) The liability of the Bank under this Guarantee shall not exceed.....<sup>4</sup>
- b) This Guarantee shall be valid up to .....<sup>5</sup>
- c) Unless the Bank is served a written claim or demand on or before \_\_\_\_\_<sup>6</sup> all rights under this guarantee shall be forfeited and the Bank shall be relieved and discharged from all liabilities under this guarantee irrespective of whether or not the original bank guarantee is returned to the Bank.

We, \_\_\_\_\_ Bank, have power to issue this Guarantee under law and the undersigned as a duly authorized person has full powers to sign this Guarantee on behalf of the Bank.

Date \_\_\_\_\_ Day of \_\_\_\_\_  
for \_\_\_\_\_(indicate the name of the Bank)\_\_\_\_\_

(Signature of Authorised signatory)

- <sup>1</sup> ADDRESS OF THE VENDOR /CONTRACTOR / SUPPLIER.
- <sup>2</sup> DETAILS ABOUT THE NOTICE OF AWARD/CONTRACT REFERENCE
- <sup>3</sup> CONTRACT VALUE
- <sup>4</sup> BG AMOUNT IN FIGURES AND WORDS
- <sup>5</sup> VALIDITY DATE (At least 3 months more than completion period)
- <sup>6</sup> DATE OF EXPIRY OF CLAIM PERIOD (At least 3 months more than the present date of validity of BG)

**Notes:**

- 1 The expiry of claim period shall be at least 3 months more than the validity date. It may be ensured that the same is in line with the agreement/ contract entered with the Vendor.
- 2 The BG should be on Non-Judicial Stamp paper/e-stamp paper of appropriate value as per Stamp Act prevailing in the State(s) where the BG is submitted or is to be acted upon or the rate

prevailing in the State where the BG was executed, whichever is higher. The Stamp Paper/e-stamp paper shall be purchased in the name of Vendor/Contractor/Supplier /Bank issuing the guarantee.

**3 In Case of Bank Guarantees submitted by Foreign Vendors:**

- a) **From Nationalized/Public Sector / Private Sector/ Foreign Banks (BG issued by Branches in India)** can be accepted subject to the condition that the Bank Guarantee should be enforceable in the town/city or at nearest branch where the Unit is located i.e. Demand can be presented at the Branch located in the town/city or at nearest branch where the Unit is located.
- b) **From Foreign Banks (wherein Foreign Vendors intend to provide BG from local branch of the Vendor country's Bank)**
  - b.1. In such cases, in the Tender Enquiry/ Contract itself, it may be clearly specified that Bank Guarantee issued by **any of the Consortium Banks only** will be accepted by BHEL. As such, Foreign Vendor needs to make necessary arrangements for issuance of Counter- Guarantee by Foreign Bank in favour of the Indian Bank's (BHEL's Consortium Bank) branch in India. It is advisable that all charges for issuance of Bank Guarantee/ counter- Guarantee should be borne by the Foreign Vendor. The tender stipulation should clearly specify these requirements.
  - b.2. In case, Foreign Vendors intend to provide BG from Overseas Branch of our Consortium Bank (e.g. if a BG is to be issued by SBI Frankfurt), the same is acceptable. However, the procedure at sl.no. b.1 will required to be followed.

**BHARAT HEAVY ELECTRICALS LIMITED**  
**DIVISION.....**  
**Running Account Bill**  
**(Para 4.3.1 of Works Accounts Manual)**

Name of the Contractor

Name of the Work:

Sanctioned Estimate:

Code No.:

Contract Agreement No.:

Dated:

Division:

Date of written order to commence the Work:

Date of commencement of work:

Due date of completion as per agreement

Date of approval of Competent Authority for time extension as applicable (copy to be enclosed).

Departmental Bill No.

Date:

Sub-Division:

Period of work covered in this bill:

**I. ACCOUNT OF WORK EXECUTED**

Adhoc payment for work not previously measured **			Item No. of work	Description of work	Quantity as per agreement	Quantity executed upto date	Rate	Unit	Payment on the basis of actual measurement upto date	Quantity executed since last RA bill	Payment on the basis of actual measurement since last running account bill	Remarks
Total as per last running account bill	Since last running account bill	Total upto date										
1	2	3	4	5	6	7	8	9	10	11	12	13

\*\* 1. Whenever payment is made on adhoc basis without actual measurements the amount in whole rupees should be entered in columns 1 to 3 only and not in columns 7 to 12  
 2. Whenever there is an entry in column 12 on the basis of actual measurement, the whole of the amount previously paid without detailed measurement should be adjusted by a minus entry in column 2 equivalent to the amount shown in column 1, so that the total upto date in column 3 may become nil.

Total value of work done upto date (A) -----

Deduct value of work shown on the last Running Account Bill (B) -----

Net value of work done since last Running Account Bill (C) -----

Rupees (in words) ..... Only

Note :

Wherever adhoc payments to contractors against running bills are made in accordance with the extant Works Policy, the amount so paid shall be adjusted.

II. MEMORANDUM OF PAYMENTS

		I	II
1.	Total value of work actually measured as per Account No. I, Column 10	(A) -----	-----
2.	Total upto date adhoc payment for work covered by approximate or plan measurements as per Account I, Col. 3	(B) -----	-----
4.	Total upto date payments [(A)+(B)]	(C) -----	-----
5.	Total amount of payments already made as per entry (D) of last Running Account Bill No. .... dated ..... forwarded to the Accounts Department on .....	(D) -----	-----
6.	Balance [(C) - (D)]		-----
7.	Payments now to be made:		
	a) by cash / cheque	-----	
	b) by deduction for value of materials supplied by BHEL vide Annexure A attached	-----	
	c) by deduction for hire of tools and plant vide Annexure B attached	-----	
	d) by deduction for other charges vide Annexure C attached	-----	
	e) by deduction on account of security deposit	-----	
	f) by deduction on account of Income Tax		-----

Note : Amounts relating to items 4 to 6 above should be entered in column II and those relating to item 7 in column I. The amount shown against item 6 and the total of item 7 should agree with each other.

III. CERTIFICATE OF THE ENGINEER IN CHARGE

1	The measurements on which the entries in column 7 to 12 of Part I of this Bill (Account of work executed) are based were made by ----- and are reorded at pages ----- of Measurement Book No. ----- (Name and Designation)
2	Certified that the methods of measurement are correct and the work has been carried out in accordance with the terms and conditions, schedules, specifications and drawings etc. forming part of the contract agreement, subject to deviations included in the deviation statement (Annexure D)
3	Certified that in addition to and quite apart from the quantities of work actually executed as shown in column 10 of Part I, some work has actually been done in connection with several items and the value of the such work is, in no case, less than the adhoc payments as per column 3 of Part I, made or proposed to be made, for the convenience of the contractor in anticipation of, and subject to the results of, detailed measurement which will be made as soon as possible.
4	Certified that measurements by Engineer-in-charge and test check of prescribed percentage of measurements by the concerned superior authorities has been carried out.
5	Certified that there are no pending recoveries from the contractor on account of chargeable items (e.g T&P, consumables, material, etc.) issued either by BHEL or by the customer and other recoveries like power, water, quarter, tax liability towards declaration forms etc.
6	Certified that with regard to the free issues, regular reconciliation is being done, completed upto ----- and there are no recoveries pending from the contractor on account of such issues in excess of requirement for execution of work as per contract.
7	Certified that there is no pending recovery for damaged material issued free of cost.
8	Certified that the contractor has fulfilled all the requirements as per contract with reference to statutory obligations (PF, ESI, Minimum Wages, BOCW, Insurance etc.), support services such as service manpower, computer system, T&P etc

Signature of Contractor

Date:

Signature of Engineer in Charge

Designation:

Date:

IV. CERTIFICATE OF THE SENIOR ENGINEER

1	Certified that the measurements have been check measured to the prescribed extent by ..... at site and also by the undersigned and the relevant entries have been initialed in the Measurement Book. (vide pages .....)	(Name and Designation)
2	Certified that all the measurements recorded in the measurement book have been correctly billed for	
3	Certified that all recoverable amounts in respect of materials tools and plant etc. and other charges have been correctly made vide annexures A to C attached.	

Certified for payment \* of Rs. .... (Rupees ..... only)

\* Here specify the net amount payable.

Date:

Signature of Senior Engineer

V. ENTRIES TO BE MADE IN THE FINANCE DEPARTMENT

Accounts Bill No. .... dated .....

Entered in Journal Book vide entry No. .... dated .....

Passed for ..... Rs. ....

Less Deductions ..... Rs. ....

Net amount payable ..... Rs. ....

(Rupees ..... only)

Payable to Shri / M/s ..... by cheque / cash

Entered in Contractors ledger No. .... Page .....

Estimate No :

Debit  
(Gross amount)

Code No.:  
ALLOCATION  
Credit  
(Deductions)

Name of Work :  
Account code head

**Total**

Assistant  
Date:

Accountant  
Date:

Finance Executive  
Date:





**BHARAT HEAVY ELECTRICALS LIMITED**  
**DIVISION.....**  
**.....And Final Bill**  
**(Para 4.3.2 of Works Accounts Manual)**

Departmental Bill No:

Date:

Name of the Contractor:

Name of the Work:

Division:

Date of Written order to commence the work:

Sub-Division:

Sanctioned Estimate:

Contract Agreement/ Work Order No:

Date of actual completion of the work:

Date of commencement of the Work:

Dated:

Due date of completion as per Agreement:

**I. ACCOUNT OF WORK EXECUTED**

Adhoc payment for work not previously measured **			Item no. of the agreement / work order	Description of work	Quantity as per agreement	Quantity executed upto date	Rate	Unit	Payment on the basis of actual measurement upto date	Quantity since last running account bill	Payment on the basis of actual measurement since last running account bill	Remarks
Total as per last running account bill	Since last running account bill	Total upto date										
1	2	3	4	5	6	7	8	9	10	11	12	13

\*\* Whenever there is an entry in column 12 on the basis of actual measurement, the whole of the amount previously paid without detailed measurement should be adjusted by a minus entry in column 2 equivalent to the amount shown in column 1, so that the total upto date in column 3 may become nil.

Total value of work done upto date (A) -----

Deduct value of work shown on the last Running Account Bill (B) -----

**Net value of work done since last Running Account Bill (C) -----**

Rupees (in words) ..... Only

II. MEMORANDUM OF PAYMENTS

1	Total value of work actually measured as per Account No. I column 10	(A)	-----
2	Deduct amount of payments already made as per last running account bill No. .... dated .....	(B)	-----
3	Payment now to be made [(A) - (B)]	(C)	-----
4	Deduct amounts recoverable from the contractor on account of :		
	a) Materials supplied by BHEL vide Annexure A attached		-----
	b) Hire of tools and plant vide Annexure B attached		-----
	c) Other charges vide Annexure C attached		-----
	d) Income Tax		-----
	Total Deductions		-----
5	Balance		-----
6	Refunds of Security Deposit		-----
7	Net amount to be paid to the contractor		-----
	Net value Rupees (in words) .....		Only

I/ We hereby certify that I/We have performed the work as per the terms and conditions of Contract Agreement/Work Order No.....Dated.....for which payment is claimed as above and that I/We have no further claim under this agreement/work order.

Signature of the Contractor

Date:

III CERTIFICATE OF THE ENGINEER IN CHARGE

1. The measurements on which the entries in columns 7 to 11 of Part I of this bill (Account of work executed) are based were made by.....  
 .....are recorded at pages.....of measurement book No..... (Name and Designation)

2. A statement showing the quantities of stores issued to the contractor (whether free or on recovery basis) and their disposal is attached.

Date:

Signature of Engineer incharge

Designation:



**ANNEXURE A  
Part I**

Statement showing details of materials issued to the contractor Shri / M/S.....in respect of Contract Agreement / Work Order No.....Dated..... and covered by the agreement.

Sl.No.	Stores Issue Voucher No. and date	Issue voucher No. and date allotted by stores to the SIV	Description of material issued issued to the contractor	Quantity issued	Quantity actually incorporated in the work	Whether recoverable from the contractor or supplied free	If recoverable from the Contractor				
							Rate at which recoverable	Amount recoverable	Amount recovered upto previous bill	Balance now recovered	Remarks
1	2	3	4	5	6	7	8	9	10	11	12
<b>Total</b>											

Signature of Contractor

Signature of Engineer in Charge

Signature of Senior Engineer

Date:

Date:

Date:

**ANNEXURE A  
Part II**

Statement showing details of materials issued to the contractor Shri / M/S.....in respect of Contract Agreement / Work Order No.....Dated..... and not covered by the agreement

Sl.No	Stores Issue Voucher No. and Date	Issue Voucher No. and date allotted by stores to the SIV	Description of material issued to the contractor	Quantity issued	Quantity actually incorporated in the work	Issue Rate	Amount recoverable	Amount recovered upto previous bill	Balance now recovered	Remarks
1	2	3	4	5	6	7	8	9	10	11

TOTAL  
Add Departmental Charges  
Add GST (Wherever applicable)  
**GRAND TOTAL**

Signature of Contractor

Signature of Engineer-in-Charge

Signature of Senior Engineer

Date:

Date:

Date:

Note: Cost of materials recovered in this bill should be shown against item 4 (a) of the memorandum of payments. The amounts of taxes and departmental charges recovered in this bill should be incorporated in Annexure C.



**ANNEXURE D  
DEVIATION STATEMENT**

Name of the Contractor:  
Name of the Work:

Contract Agreement/Work Order No.  
Date:

SL. No.	Description of Item	Unit	Quantity as per agreement	Quantity as executed	Rate as per agreement	Rate as executed	Amount as per agreement	Amount as executed	Difference		Reason for the deviation with authority, if any
									Excess	Savings	
1	2	3	4	5	6	7	8	9	10	11	12

Signature of Engineer in Charge  
Date:

Signature of Senior Engineer  
Date:

**ANNEXURE E**

Statement showing the consumption of material issued to the contractor Shri/Ms..... in respect of Contract Agreement / Work Order No.....Dated.....

Name of the Work:

**ON RECOVERY BASIS**

SL. No.	Description of material	Unit	Quantity actually issued	Quantity actually incorporated in the work	Balance	Particulars of disposal of balance	Quantity to be issued as per approved data for work actually done	Variation in consumption (difference between column 5 & 8)		Rate chargeable for excess/short consumption, if any	Amount Recoverable for excess/short consumption, including materials not returned, if any	Remarks
								More	Less			
1	Cement											
2	Bricks											
3	Wood											
4	Asbestos Sheet											
5	Iron Material											
6												
7												

Signature of Contractor  
Date:

Signature of Engineer in Charge  
Date:

Signature of Senior Engineer  
Date:

Note

- The quantities shown in columns 4 and 5 above should tally with those shown in columns 5 & 6 respectively of Annexure A (Part I and II)
- Data statement of theoretical consumption should be attached in support of quantity specified in column 8.

ANNEXURE F

Form WAM 7 (Contd.)

Statement showing details of materials issued to the contractor Shri/M/s..... in respect of Contract Agreement / Work Order No.....dated.....

Name of the Work:

FREE OF COST

Sl.No	Stores Issue Voucher No.	Description of material	Unit	Quantity issued	Quantity required as per data	Quantity consumed in the work	Balance (if any)	Nature of disposal for the balance	Rate chargeable for material not returned	Amount recoverable for material not returned	Remarks
1	2	3	4	5	6	7	8	9	10	11	12

Signature of Contractor  
Date:

Signature of Engineer In Charge  
Date:

Signature of Senior Engineer  
Date:

**ANNEXURE G**  
**QUESTIONNAIRE TO BE ANSWERED BY THE ENGINEER IN CHARGE AND SENIOR ENGINEER**  
**(Correct particulars and answers to be recorded)**

1. Name of the Work:
2. Name of the Contractor:
3. Date of commencement of the Work:
4. Contract agreement /Work Order No. and date:
5. Reference to the supplementary Agreement No. if any:
6. Whether administrative approval and technical sanction has been accorded by the competent authority? If so, cite reference?
7. Whether sanction of the competent authority and financial concurrence of the Finance Department for award of the work has been accorded? If so, cite reference.
8. Whether the work has been completed in time? If not whether penalty has been levied or sanction of the competent authority for extension of time granted and communicated to the Finance Department with reasons for grant of extension? (Due and actual date of completion of the work and reference to letter No. and date granting the extension of time should be given).
9. (a) Whether the rates allowed in the bill have been checked with the contract agreement?  
 (b) Whether the rates for extra/supplemental items have been approved by the competent authority and the sanction communicated to the Finance Department together with rate analysis? If so, cite reference
10. Whether deviations have been approved by the competent authority? If yes, give reference to the approval; if not, give reasons.
11. Whether the rates of recovery of stores issued to the contractor which are not provided for in the contract agreement have been settled in consultation with Finance?
12. Whether discrepancies pointed out by the Finance department in the stores statement have been reconciled and accepted by the Finance Department?
13. Whether materials issued to the contractor in excess of the theoretical requirements have been returned to the Stores department and the No. and date of such returned stores vouchers have been shown in Stores statement? If not, whether the cost of such excess materials has been recovered at the prescribed rate? Whether consumption statements in respect of materials chargeable to the work have been attached to the bill?
14. Whether consumption of materials shown has been technically checked by Senior Engineer?
15. Whether materials issued and used in the work is not less than that required for consumption in work according to our specifications? If consumption is less, whether necessary recovery has been made in the bill?
16. Whether measurements have been checked by the Engineer and Senior Engineer to the extent required and certificates of check recorded in the measurement books?
17. Whether contractor has signed the bill and the measurement books without reservations? If not, whether reasons have been intimated to the Finance Department?
18. Whether arithmetical calculations have been checked and certificate recorded in the measurement books by a person other than the one who calculated initially?
19. Whether any work was done at the risk and cost of the contractor and whether such cost has been recovered from him? Give particulars.
20. Whether all advance payments on running accounts have been recovered?
21. Whether all the recoveries due for services given to the contractor like rent of accommodation, water charges, electricity charges have been recovered and whether payments made by the company on behalf of the contractor have been adjusted?
22. Whether the files containing abstracts from measurement books/standard measurement books have been completed/updated?
23. Whether hire charges for tools & plant have been recovered and the statement of hire charges with full details attached?
24. Whether the certificate of workmanship and completion of work according to specifications, drawings etc. is recorded by Engineer Incharge/Senior Engineer and whether recoveries have been made for defective works, if any?
25. Whether all corrections in the bill/measurement books etc. have been neatly made and attested and there are no overwriting?
26. Whether final measurements have been taken as soon as possible after completion of the work and the certificate of completion issued? If not, whether reasons for delay have been recorded and communicated to finance department?
27. In respect of quantities reduced in the final bill as compared to the running payment, whether adequate reasons have been recorded and communicated to finance department?
28. Whether the expenditure has been classified correctly according to heads of account recorded in the sanctioned estimate?
29. Whether the work has been completed within the estimated cost? If not, what is the percentage of excess over the sanctioned estimate/ administrative approval? In case the excess is beyond the competency of the Senior Engineer, what action has been taken for obtaining the approval of the authority competent to sanction the excess?
30. (a) If the contractor has furnished bank guarantee in lieu of cash security deposit towards proper execution of works and guarantee against defects during the maintenance period, whether the period of currency of the bank guarantee covers the entire maintenance period?  
 (b) If not whether security deposit has been proposed to be recovered from the final bill?
31. Whether all the previous audit objections raised on running account bills have been settled? If so, cite references.

**ANNEXURE TO MODEL CONCILIATION CLAUSE FOR CONDUCT OF CONCILIATION UNDER THE BHEL CONCILIATION SCHEME, 2018**

**BRIEF PROCEDURE FOR CONDUCT OF CONCILIATION PROCEEDINGS**

1. The proceedings of Conciliation shall broadly be governed by Part-III of the Arbitration and Conciliation Act 1996 or any statutory modification thereof and as provided herein:
2. The party desirous of resorting to Conciliation shall send an invitation/notice in writing to the other party to conciliate specifying all points of Disputes with details of the amount claimed. The party concerned shall not raise any new issue thereafter. Parties shall also not claim any interest on claims/counter-claims from the date of notice invoking Conciliation till the conclusion of the Conciliation proceedings.
3. The party receiving the invitation/notice for Conciliation shall within 30 days of receipt of the notice of Conciliation intimate its consent for Conciliation along with its counter-claims, if any.
4. The Conciliation in a matter involving claim or counter-claim (whichever is higher) up to Rs 5 crores shall be carried out by sole Conciliator nominated by BHEL while in a matter involving claim or counter-claim (whichever is higher) of more than Rs 5 crores Conciliation shall be carried out by 3 Conciliators nominated by BHEL.
5. The Parties shall be represented by only their duly authorized in-house executives/officers and neither Party shall be represented by a Lawyer.
6. The first meeting of the IEC shall be convened by the IEC by sending appropriate communication/notice to both the parties as soon as possible but not later than 30 days from the date of his/their appointment. The hearings in the Conciliation proceeding shall ordinarily be concluded within two (2) months and, in exceptional cases where parties have expressed willingness to settle the matter or there exists possibility of settlement in the matter, the proceedings may be extended by the IEC by a maximum of further 2 months with the consent of the Parties subject to cogent reasons being recorded in writing.
7. The IEC shall thereafter formulate recommendations for settlement of the Disputes supported by reasons at the earliest but in any case within

15 days from the date of conclusion of the last hearing. The recommendations so formulated along with the reasons shall be furnished by the IEC to both the Parties at the earliest but in any case within 1 month from the date of conclusion of the last hearing.

8. Response/modifications/suggestions of the Parties on the recommendations of the IEC are to be submitted to the IEC within time limit stipulated by the IEC but not more than 15 days from the date of receipt of the recommendations from the IEC.
9. In the event, upon consideration, further review of the recommendations is considered necessary, whether by BHEL or by the other Party, then, the matter can be remitted back to the IEC with request to reconsider the same in light of the issues projected by either/both the Parties and to submit its recommendations thereon within the following 15 days from the date of remitting of the case by either of the Parties.
10. Upon the recommendations by the Parties, with or without modifications, as considered necessary, the IEC shall be called upon to draw up the Draft Settlement Agreement in terms of the recommendations.
11. When a consensus can be arrived at between the parties only in regard to any one or some of the issues referred for Conciliation the draft Settlement Agreement shall be accordingly formulated in regard to the said Issue(s), and the said Settlement Agreement, if signed, by the parties, shall be valid only for the said issues. As regards the balance issues not settled, the parties may seek to resolve them further as per terms and conditions provided in the contract.
12. In case no settlement can be reached between the parties, the IEC shall by a written declaration, pronounce that the Conciliation between the parties has failed and is accordingly terminated.
13. Unless the Conciliation proceedings are terminated in terms of para 22 (b), (c) & (d) herein below, the IEC shall forward his/its recommendations as to possible terms of settlement within one (1) month from the date of last hearing. The date of first hearing of Conciliation shall be the starting date for calculating the period of 2 months.

14. In case of 3 members IEC, 2 members of IEC present will constitute a valid quorum for IEC and meeting can take place to proceed in the matter after seeking consent from the member who is not available. If necessary, videoconferencing may be arranged for facilitating participation of the members. However, the IEC recommendations will be signed by all members. Where there is more than one (1) Conciliator, as a general rule they shall act jointly. In the event of differences between the Members of IEC, the decision/recommendations of the majority of the Members of IEC shall prevail and be construed as the recommendation of the IEC.
15. The Draft Settlement Agreement prepared by the IEC in terms of the consensus arrived at during the Conciliation proceedings between the Parties shall be given by the IEC to both the parties for putting up for approval of their respective Competent Authority.
16. Before submitting the draft settlement agreement to BHEL's Competent Authority viz. the Board Level Committee on Alternative Dispute Resolution (BLCADR) for approval, concurrence of the other party's Competent Authority to the draft settlement agreement shall be obtained by the other party and informed to BHEL within 15 days of receipt of the final draft settlement agreement by it. Upon approval by the Competent Authority, the Settlement Agreement would thereafter be signed by the authorized representatives of both the Parties and authenticated by the members of the IEC.
17. In case the Draft Settlement Agreement is rejected by the Competent Authority of BHEL or the other Party, the Conciliation proceedings would stand terminated.
18. A Settlement Agreement shall contain a statement to the effect that each of the person(s) signing thereto (i) is fully authorized by the respective Party(ies) he/she represents, (ii) has fully understood the contents of the same and (iii) is signing on the same out of complete freewill and consent, without any pressure, undue influence.
19. The Settlement Agreement shall thereafter have the same legal status and effect as an arbitration award on agreed terms on the substance of the dispute rendered by an arbitral tribunal passed under section 30 of the Arbitration and Conciliation Act, 1996.
20. Acceptance of the Draft Settlement Agreement/recommendations of the Conciliator and/or signing of the Settlement Agreement by BHEL shall

however, be subject to withdrawal/closure of any arbitral and/or judicial proceedings initiated by the concerned Party in regard to such settled issues.

21. Unless otherwise provided for in the agreement, contract or the Memorandum of Understanding, as the case may be, in the event of likelihood of prolonged absence of the Conciliator or any member of IEC, for any reason/incapacity, the Competent Authority/Head of Unit/Division/Region/Business Group of BHEL may substitute the Conciliator or such member at any stage of the proceedings. Upon appointment of the substitute Conciliator(s), such reconstituted IEC may, with the consent of the Parties, proceed with further Conciliation into the matter either de-novo or from the stage already reached by the previous IEC before the substitution.

22. The proceedings of Conciliation under this Scheme may be terminated as follows:

- a. On the date of signing of the Settlement agreement by the Parties; or,
- b. By a written declaration of the IEC, after consultation with the parties, to the effect that further efforts at conciliation are no longer justified, on the date of the declaration; or,
- c. By a written declaration of the Parties addressed to the IEC to the effect that the Conciliation proceedings are terminated, on the date of the declaration; or,
- d. By a written declaration of a Party to the other Party and the IEC, if appointed, to the effect that the Conciliation proceedings are terminated, on the date of the declaration.
- e. On rejection of the Draft Settlement Agreement by the Competent Authority of BHEL or the other Party.

23. The Conciliator(s) shall be entitled to following fees and facilities:

<b>Sl No</b>	<b>Particulars</b>	<b>Amount</b>
1	Sitting fees	Each Member shall be paid a Lump Sum fee of Rs 75,000/- for the whole case payable in terms of paragraph No. 27 herein below.
2	Towards drafting of settlement agreement	In cases involving claim and/or counter-claim of up to Rs 5crores. Rs 50,000/- (Sole Conciliator)

Sl No	Particulars	Amount
		<p>In cases involving claim and/or counter-claim of exceeding Rs 5 crores but less than Rs 10 crores. Rs 75,000 (per Conciliator)</p> <p>In cases involving claim and/or counter-claim of more than Rs 10 crores. Rs 1,00,000/- (per Conciliator)</p> <p>Note: The aforesaid fees for the drafting of the Settlement Agreement shall be paid on Signing of the Settlement Agreement after approval of the Competent Authority or Rejection of the proposed Settlement Agreement by the Competent Authority of BHEL.</p>
3	Secretarial expenses	<p>Rs 10,000/- (one time) for the whole case for Conciliation by a Sole Member IEC.</p> <p>Where Conciliation is by multi member Conciliators –Rs 30,000/- (one time)- to be paid to the IEC</p>
4	<p>Travel and transportation and stay at outstation</p> <p>i) Retired Senior Officials of other Public Sector Undertakings (pay scale wise equivalent to or more than E-8 level of BHEL)</p>	<p>As per entitlement of the equivalent officer (pay scale wise) in BHEL.</p>
	Others	<p>As per the extant entitlement of whole time Functional Directors in BHEL.</p>

Sl No	Particulars	Amount
		Ordinarily, the IEC Member(s) would be entitled to travel by air Economy Class.
5	Venue for meeting	Unless otherwise agreed in the agreement, contract or the Memorandum of Understanding, as the case may be, the venue/seat of proceedings shall be the location of the concerned Unit / Division / Region / Business Group of BHEL. Without prejudice to the seat/venue of the Conciliation being at the location of concerned BHEL Unit / Division / Region / Business Group, the IEC after consulting the Parties may decide to hold the proceedings at any other place/venue to facilitate the proceedings. Unless, Parties agree to conduct Conciliation at BHEL premises, the venue is to be arranged by either Party alternately.

24. The parties will bear their own costs including cost of presenting their cases/evidence/witness(es)/expert(s) on their behalf. The parties agree to rely upon documentary evidence in support of their claims and not to bring any oral evidence in IEC proceedings.
25. If any witness(es) or expert(s) is/are, with the consent of the parties, called upon to appear at the instance of the IEC in connection with the matter, then, the costs towards such witness(es)/expert(s) shall be determined by the IEC with the consent of the Parties and the cost so determined shall be borne equally by the Parties.
26. The other expenditures/costs in connection with the Conciliation proceedings as well as the IEC's fees and expenses shall be shared by the Parties equally.
27. Out of the lump sum fees of Rs 75,000/- for Sitting Fees, 50% shall be payable after the first meeting of the IEC and the remaining 50% of the Sitting Fees shall be payable only after termination of the conciliation proceedings in terms of para 22 hereinabove.

28. The travelling, transportation and stay at outstation shall be arranged by concerned Unit as per entitlements as per Serial No. 3 of the Table at para 23 above, and in case such arrangements are not made by the BHEL Unit, the same shall be reimbursed to the IEC on actuals limited to their entitlement as per Serial No. 4 of the Table at Para 23 above against supporting documents. The IEC Member(s) shall submit necessary invoice for claiming the fees/reimbursements.
29. The Parties shall keep confidential all matters relating to the conciliation proceedings. Confidentiality shall extend also to the settlement agreement, except where its disclosure is necessary for purposes of its implementation and enforcement or as required by or under a law or as per directions of a Court/Governmental authority/regulatory body, as the case may be.
30. The Parties shall not rely upon or introduce as evidence in any further arbitral or judicial proceedings, whether or not such proceedings relate to the Disputes that is the subject of the Conciliation proceedings:
  - a. Views expressed or suggestions made by the other party in respect of a possible settlement of the Disputes;
  - b. admissions made by the other party in the course of the Conciliator proceedings;
  - c. proposals made by the Conciliator;
  - d. The fact that the other Party had indicated his willingness to accept a proposal for settlement made by the Conciliator.
31. The Parties shall not present the Conciliator(s) as witness in any Alternative Dispute Resolution or Judicial proceedings in respect of a Disputes that is/was the subject of that particular Conciliation proceeding.
32. None of the Conciliators shall act as an arbitrator or as a representative or counsel of a Party in any arbitral or judicial proceeding in respect of a Disputes that is/was the subject of that particular Conciliation proceeding.
33. The Parties shall not initiate, during the Conciliation proceedings, any arbitral or judicial proceedings in respect of a Disputes that is the subject matter of the Conciliation proceedings except that a Party may initiate arbitral or judicial proceedings where, in his opinion, such proceedings are necessary for preserving his rights including for preventing expiry of period of limitation. Unless terminated as per the provisions of this Scheme, the Conciliation proceedings shall continue

notwithstanding the commencement of the arbitral or judicial proceedings and the arbitral or judicial proceedings shall be primarily for the purpose of preserving rights including preventing expiry of period of limitation.

34. The official language of Conciliation proceedings under this Scheme shall be English unless the Parties agree to some other language.

**Format 2 to BHEL Conciliation Scheme, 2018**

**FORMAT FOR SEEKING CONSENT FOR REFERRING THE DISPUTES TO  
CONCILIATION THROUGH IEC**

To,

M/s. (Stakeholder's name)

**Sub: Resolution of the Disputes through conciliation by Independent  
Expert Committee (IEC).**

Ref: Contract No/MoU/Agreement/LOI/LOA& date \_\_\_\_\_.

Sir,

With reference to above referred Contract/MoU/Agreement/LOI/LOA, you have raised certain Disputes/claims. Vide your letter dated\_\_\_\_\_ you have requested BHEL to refer the Disputes/claims to IEC for Conciliation.

We are enclosing herewith Format (3) for giving consent and the terms and conditions of BHEL Conciliation Scheme, 2018 governing conciliation through IEC. You are requested to give your unconditional consent to the said terms and conditions of the Scheme by returning the same duly sealed and signed on each page. On receipt of your consent, matter will be put to the Competent Authority for consideration and decision.

Please note that BHEL has also certain claims against you (if applicable). BHEL reserves its right to agree or not to agree conciliation of the said disputes through BHEL and this letter is being issued without prejudice to BHEL's rights and contentions available under the contract and law.

Yours faithfully,

**Representative of BHEL**

**Format 3 to BHEL Conciliation Scheme, 2018**  
**FORMAT FOR GIVING CONSENT BY**  
**CONTRACTOR/VENDOR/CUSTOMER/COLLABORATOR/CONSORTIUM PARTNERS FOR REFERRING THE DISPUTES TO CONCILIATION THROUGH IEC**

To,

BHEL

.....

**Sub: Resolution of Disputes through Conciliation by Independent Expert Committee (IEC).**

Ref: Contract/MoU/Agreement/LOI/LOA No & date\_\_\_\_

With reference to above referred contract, our following bills/invoices/claims submitted to BHEL are still unpaid giving rise to Disputes:

SL. no.	Claim Description	Bill submitted to BHEL (no. and date)	Amount of the bill/claim	Amount received from BHEL	Outstanding Amount

Accordingly we request you to kindly refer the Disputes in respect of above claims to IEC for Conciliation.

We hereby agree and give our unconditional consent to the terms and conditions of BHEL Conciliation Scheme, 2018 governing conciliation through IEC. We have signed the same on each page and enclosed it for your consideration.

Yours faithfully,

**(Signature with stamp)**

**Authorized Representative of Contractor**

**Name, with designation**

**Date**

**Format 5 to BHEL Conciliation Scheme, 2018**  
**STATEMENT OF CLAIMS/COUNTER CLAIMS TO BE SUBMITTED TO**  
**THE IEC BY BOTH THE PARTIES**

1. Chronology of the Disputes
2. Brief of the Contract/MoU/Agreement/LOI/LOA
3. Brief history of the Disputes:
4. Issues:
5. Details of Clam(s)/Counter Claim(s):

<b>SI. No.</b>	<b>Description of claim(s)/Counter Claim</b>	<b>Amount (in INR)Or currency applicable in the contract</b>	<b>Relevant contract clause</b>

6. Basis/Ground of claim(s)/counter claim(s) (along with relevant clause of contract)

**Note**– *The Statement of Claims/Counter Claims may ideally be restricted to maximum limit of 20 pages. Relevant documents may be compiled and submitted along with the statement of Claims/Counter Claims. The statement of Claims/Counter Claims is to be submitted to all IEC members and to the other party by post as well as by email.*

**BILL OF QUANTITIES CUM PRICE SCHEDULE (ANNEXURE-I)**

**Project :** 2 X 800 MW NTPC LARA STAGE-II, CHHATTISGARH

**Name of Work:** PRELIMINARY, DETAILED & CHECK ROUTE SURVEY AND GEOTECHNICAL INVESTIGATION ALONG WITH DESIGN AND ENGINEERING WORKS FOR 400kV TRANSMISSION LINE AT 2 X 800 MW NTPC LARA STAGE-II, CHHATTISGARH

**Tender Spec. No.:** TBSM/LARA/SURVEY/TENDER/24-25 DATE: 09.05.2024

Sr. No.	Description of Item	UOM	Quantity	Unit Rate	Amount
<b>1</b>	<b>Reconnaissance &amp; Preliminary Survey</b>				
1 (a)	Conducting reconnaissance/walkover & preliminary survey using GPS and Topo sheets for the suggestive corridor/Right of way by NTPC (end-client) as per attached drawing at Annexure-2, suggesting best alternative route (if required), identifying/fixing points for crossing such as river, railway, power line, telecom, road forest, identification of any existing structure to be dismantled, fixing of angle points & submission of preliminary survey report all complete as per project specification & directions of BHEL including its approval from BHEL/customer	km	1.2	₹ 2,83,333.33	₹ 3,40,000.00
<b>2</b>	<b>Detailed &amp; Check Survey</b>				
2(a)	<b>Detailed Survey:</b> Detailed survey including modification in preliminary route alignment, adjustment in section details to achieve better average span, profiling, collecting actual field data along the selected route (enumeration of salient land features like crossing of rivers, nalla, road, railway lines, other transmission / distribution line, nearby habitations, forest land, proximity to airport, etc.), tower spotting & providing tower schedule with detailed land schedule (Plot no./khata no., etc) for each tower location, estimation of tower quantities with extension and special tower requirement (if any), marking on khasra map and topographical sheets, detailed bill of quantity for transmission line material, sag template, tree enumeration, etc. & submission of detailed survey report, including check survey all complete as per project specification & directions of BHEL including its approval from BHEL/Customer.  (Check survey to be done in liasoning with civil agency. All details in this regard to be issued to civil agency so that construction can be taken up)  (a) 80% payment for completion of all activities except check survey (b) 20% payment after completion of check survey	km	1.2	₹ 4,25,000.00	₹ 5,10,000.00
2(b)	Check survey: Survey for route alignment to locate and peg mark tower positions on ground conforming to approved profile and tower schedule. Changes, if required, after detailed survey in tower scheudle shall be carried out and thereafter submit tower schedule for approval. The tower schedule shall show position of all towers, type of towers, span length, type of foundation for each tower and the deviation. Check survey to be done in liasing with civil work agency finalised by BHEL. (All details in this regard to be issued to civil agency so that construction can be taken up)	km	1.2		
<b>3</b>	<b>Geotechnical investigation &amp; soil resistivity measurements</b>				
3(a)	Conducting detailed soil investigation at various tower locations & other locations as per instructions of BHEL/customer including mobilization of necessary equipment, providing necessary engineering supervision and technical personnel, carrying out field investigations and tests, laboratory tests, analysis and interpretation of data and results and working out tentative quantity of foundation work, preparations for the type of foundation and the safe bearing capacity for different sizes of foundations, different foundation strata for various locations along the transmission line all complete, submission of report as per project specification & direction of BHEL including its approval from BHEL/customer	Nos	6	₹ 70,833.33	₹ 4,25,000.00
3(b)	Performing soil resistivity along the route for each tower location and working out tentative quantity of earthing material all complete as per project specification & directions of BHEL including its approval from BHEL/customer	Nos	6		
<b>4</b>	<b>Design and engineering - All Other Documents</b>				
4	Preparation & submission of design documents & drawing for Pole structure (11 kV) foundation based on approved loads on foundations & Bearing Capacity of 10T/sqm. all complete as per project specific specification & directions of BHEL including their approval from BHEL/Customer's Engineer/Customer.	Lot	1	₹ 12,75,000.00	₹ 12,75,000.00
<b>TOTAL AMOUNT (excluding GST)</b>					<b>₹ 25,50,000.00</b>

Validate

Print

Help

**Percentage BoQ**

Tender Inviting Authority: BHEL, TBG- SubContracting Department, Sector 16A Noida, UP

Name of Work: TENDER FOR "PRELIMINARY, DETAILED & CHECK ROUTE SURVEY AND GEOTECHNICAL INVESTIGATION ALONG WITH DESIGN AND ENGINEERING WORKS FOR 400kV TRANSMISSION LINE AT 2 X 800 MW NTPC LARA STAGE-II, CHHATTISGARH"

Contract No:TBSM/LARA/SURVEY/TENDER/24-25 DATE: 09.05.2024

Name of the Bidder/ Bidding Firm / Company :	
--	--

**PRICE SCHEDULE**

(This BOQ template must not be modified/replaced by the bidder and the same should be uploaded after filling the relevent columns, else the bidder is liable to be rejected for this tender. Bidders are allowed to enter the Bidder Name and Values only )

NUMBER #	TEXT #	NUMBER #	TEXT #	NUMBER	NUMBER #	TEXT #
Sl. No.	Item Description	Quantity	Units	Estimated Rate in Rs. P	TOTAL AMOUNT Without Taxes in Rs. P	TOTAL AMOUNT In Words
1	2	4	5	6	53	55
1	Total amount as per rates in BOQ (as per Annexure-I) for "PRELIMINARY, DETAILED & CHECK ROUTE SURVEY AND GEOTECHNICAL INVESTIGATION ALONG WITH DESIGN AND ENGINEERING WORKS FOR 400kV TRANSMISSION LINE AT 2 X 800 MW NTPC LARA STAGE-II, CHHATTISGARH."- Excluding GST	1.000	Nos	2550000.00	2550000.00	INR Twenty Five Lakh Fifty Thousand Only
<b>Total in Figures</b>					<b>2550000.00</b>	INR Twenty Five Lakh Fifty Thousand Only
<b>Quoted Rate in Figures</b>			Select		<b>0.000</b>	INR Zero Only
<b>Quoted Rate in Words</b>		<b>INR Zero Only</b>				



# BHARAT HEAVY ELECTRICALS LIMITED

## TRANSMISSION BUSINESS HVDC ENGINEERING & SYSTEMS

**COPYRIGHT AND CONFIDENTIALITY**  
 The information on this document is the property of BHARAT HEAVY ELECTRICALS LTD.  
 It must not be used directly or indirectly in anyway detrimental to the interest of the company

DOCUMENT No.	TB-423-607-000-TL-PKG-I	Rev.No.	01	Prepared	Checked	Approved		
TYPE OF DOC.	TECHNICAL SPECIFICATION	SIGN						
TITLE	<b>Technical specification for SURVEY, DESIGN &amp; ENGINEERING WORK FOR 400kV TRANSMISSION LINE</b>	NAME	MSP	NK	SKS			
		DATE						
		GROUP	TBEM	W.O. No				
Customer/Consultant	NTPC LIMITED							
PROJECT	2 X 800 MW NTPC LARA STPS STAGE-II SWITCHYARD							
NOA No.	CS-9587-001R-2-SCNOA- 7333 dtd 29.08.2023 CS-9587-001R-2-FCNOA- 7332 dtd 29.08.2023							
CONTENTS								
Section	Description	PAGES						
1	SCOPE, BILL OF QUANTITY, SPECIFIC TECHNICAL REQUIREMENT	5						
2	STANDARD TECHNICAL SPECIFICATION	NA						
3	ENCLOSURE TO SPECIFICATION:  (A) CUSTOMER TECHNICAL SPECIFICATION (B) PROJECT INFORMATION (C) TENDER DRAWINGS	77						
Rev No.	Date	Altered	Checked	Approved	REVISION DETAILS			
Distribution				To	TBEM	TBMM	TBQM	Vendor
				Copies	1	1	1	4

<b>PROJECT: 400kV Switchyard for LARA SUPER THERMAL POWER PROJECT (2x800MW)</b> <b>CUSTOMER: NTPC LTD.</b>
---

<b>Technical specification for Survey, Design &amp; Engineering work for 400kv Transmission line</b> <b>Section-1: Scope, Specific Technical Requirements &amp; Quantities</b>	<b>TB-423-607-000-TL-PKG-I</b> <b>REV.00</b>
---	---

## SECTION -1

### SCOPE, SPECIFIC TECHNICAL REQUIREMENT & QUANTITIES

#### **1.0 INTRODUCTION**

1.1.0 The intent of this specification is to specify all details required by a Transmission Line survey and Geotechnical investigation for:

1.1.1 Conducting Transmission Line route survey, tower spotting/optimization of tower location, soil resistivity measurements and geotechnical investigation (as per NTPC specification enclosed), required for construction of transmission line project being executed by BHEL on turnkey basis for NTPC.

1.1.2 Quoting his most competitive rates for items indicated in Annexure-1 of this specification.

1.1.3 The above mentioned Transmission Line shall be interconnecting the AIS Extension of LARA STAGE-I (I-type configuration) to new AIS of LARA STAGE-II (D-type configuration) through 400kV Double Circuit line using Quad moose conductor.

1.1.4 For detailed technical specification for Survey & Geotechnical investigation, please refer Section-3 (NTPC specification).

1.1.5 For Project Details refer Section-3 attached.

#### **2.0 SCOPE**

2.1.0 The detailed scope of work under this specification is as following:

2.1.1 Carrying out preliminary/walkover survey using GPS and Topo sheets for the suggestive corridor/Right of way by NTPC (end-client) as per attached drawing at Annexure-2, suggesting best optimum alternative route (if required), identifying/fixing points for crossing such as river, railway, power line, telecom, road forest, identification of any existing structure to be dismantled, fixing of angle points & submission of preliminary survey report, profile plotting, sag template preparation, tower spotting, preliminary schedules (tower schedules indicating type of towers, extension, etc. inline with already available type tested tower design available with any power utility in India) & other detail preparations.

**PROJECT: 400kV Switchyard for LARA SUPER THERMAL POWER PROJECT (2x800MW)**  
**CUSTOMER: NTPC LTD.**

**Technical specification for Survey, Design & Engineering work for 400kv Transmission line**  
**Section-1: Scope, Specific Technical Requirements & Quantities** **TB-423-607-000-TL-PKG-I**  
**REV.00**

- 2.1.2 Detailed survey including modification in preliminary route alignment, adjustment in section details to achieve better average span, profiling, collecting actual field data along the selected route (enumeration of salient land features like crossing of rivers, nalla, road, railway lines, piping, other transmission/distribution line, nearby habitations, forest land, proximity to airport, etc.), tower spotting & **providing tower schedule (showing no & types of tower)** with detailed land schedule (Plot no/Khata no., etc) for each tower location, estimation of tower quantities with extension and special tower requirement, sag template, marking on Khasra map and topographical map, tree enumeration, etc. & submission of detailed survey report along with route profiling drawing, all complete as per technical specifications & directions of Engineering In-charge including its approval from BHEL/customer.
- 2.1.3 Carrying out check-survey for route alignment to locate and peg mark tower positions conforming to approved profile, tower schedule and technical specifications. Changes, if required in tower schedule after detailed survey, shall be carried out and thereafter submit revised tower schedule for approval. The tower schedule shall show co-ordinates of all towers, type of towers, span length, type of foundation for each tower and the deviation. (Check survey to be done jointly in presence of civil work agency finalised by BHEL)
- 2.1.4 Conducting detailed soil investigation at various tower locations and at other locations as necessary including mobilization of necessary equipment, providing necessary engineering supervision and technical personal, carrying out field investigation and tests, laboratory tests, analysis and interpretation of data and results, collecting data regarding change of course of rivers from local sources, velocity, scour, etc. giving floor details of the area (past history), preparations for the type of foundations, and safe bearing capacity for different size of foundations, different founding strata for the various locations along the transmission lines.
- 2.1.5 Conducting Electrical Resistivity Test of soil at various tower locations including submission of test report for approval of BHEL/Customer including mobilization of

<b>PROJECT: 400kV Switchyard for LARA SUPER THERMAL POWER PROJECT (2x800MW)</b> <b>CUSTOMER: NTPC LTD.</b>	
<b>Technical specification for Survey, Design &amp; Engineering work for 400kv Transmission line</b> <b>Section-1: Scope, Specific Technical Requirements &amp; Quantities</b>	<b>TB-423-607-000-TL-PKG-I</b> <b>REV.00</b>

necessary equipment, tools, manpower etc complete as per relevant IS Code, Technical specification and Instruction of Engineer-In-charge

2.1.6 Preparation of Bill of quantity in attached format at Annexure-1.

2.1.7 Design calculations, drawings & documents are required to be furnished after successful award of contract.

2.1.8 Getting all the works as mentioned above approved by BHEL/customer.

2.1.9 The Bidder shall depute his engineer(s) to Site or BHEL's/Customer's office/Supplier's works for any clarification etc. as required by BHEL/Customer. Bidder shall also depute his engineer(s) to site for check surveys also.

2.1.10 Preparation & submission of design documents of Transmission line and their tower foundations, bill of material of hardware etc. The detailed design & drawing work shall include, but not limited to:

- Verification of all data, criteria and information contained in the contract documents.
- Generation of all data, criteria and information required for the completion of work including liaison and interface with BHEL/Customer/Customer's Engineer.
- Design and Drawings of foundation for Towers for different soil types including Dry, Wet, Partially Submerged, Fully Submerged, etc including Foundation loading data.
- Preparation of construction drawings with sufficient detailing so that no difficulty is faced by site engineers during execution.

2.1.11 Getting all the works mentioned above approved by BHEL/Customer's Engineer/Customer.

2.1.12 Preparation and submission including its approval from BHEL/Customer of the following drawing/documents:

- (a) Bill of Material for transmission line material including conductor, conductor accessories, earthwire, ADSS Optical Fiber Cable, earth wire/OPGW accessories, ADSS Optical Fiber Cable accessories, stringing hardware, disc insulators etc

<b>PROJECT: 400kV Switchyard for LARA SUPER THERMAL POWER PROJECT (2x800MW)</b> <b>CUSTOMER: NTPC LTD.</b>	
<b>Technical specification for Survey, Design &amp; Engineering work for 400kv Transmission line</b> <b>Section-1: Scope, Specific Technical Requirements &amp; Quantities</b>	<b>TB-423-607-000-TL-PKG-I</b> <b>REV.00</b>

- (b) Sag profile, Erection Key Diagram
- (c) Stringing chart of all spans for conductor, earth wire, ADSS cable etc., including damper placement chart as applicable.
- (d) Earthing details of Towers.
- (e) Design basis report of distribution line
- (f) Transmission Line geotechnical investigation report including resistivity report.
- (g) Transmission Line detailed route survey & check survey, tower spotting (preferably for Single type of tower for all locations with different leg extensions, etc based on requirement) & transmission line profile.
- (h) Any other drawing/documents required for successful completion of the work.

### **3.0 SPECIFIC TECHNICAL REQUIREMENTS**

- 3.1.0 The specific technical requirements shall be as per project specific input provided by BHEL from time to time after award of work.
- 3.2.0 The Bidder shall interact closely with BHEL engineering group for any input/clarification and finalize details across the table. There may be certain cases when on account of revision or change of inputs, certain survey/ design / drawing may be required to be redone. **No claim on account of this shall be entertained.** Only suitable time extension shall be granted on account of above.
- 3.3.0 The bidder / representatives of bidder may be required to make several visits to site / BHEL office / customer's office depending upon the project requirements. **No extra claim on account of these visits shall be entertained.**

### **4.0 SCHEDULE/BOQ OF ITEMS**

- 4.1.0 The Schedule/BOQ of Items shall be as per **Annexure 1**. The Bidder is required to quote his most competitive rate for these items.

### **5.0 DOCUMENTATION**

- 5.1.0 All design documents including computer outputs shall be neatly typed, produced on A4 size paper and shall have a 'Cover Sheet' (To be provided later).



# BHARAT HEAVY ELECTRICALS LIMITED

## TRANSMISSION BUSINESS HVDC ENGINEERING & SYSTEMS

**COPYRIGHT AND CONFIDENTIALITY**  
The information on this document is the property of BHARAT HEAVY ELECTRICALS LTD.  
It must not be used directly or indirectly in anyway detrimental to the interest of the company

DOCUMENT No.	TB-423-607-000-TL-PKG-I	Rev.No.	01	Prepared	Checked	Approved		
TYPE OF DOC.	TECHNICAL SPECIFICATION			SIGN				
TITLE	<b>Technical specification for SURVEY, DESIGN &amp; ENGINEERING WORK FOR 400kV TRANSMISSION LINE</b>	NAME	MSP	NK	SKS			
		DATE						
		GROUP	TBEM	W.O. No				
Customer/ Consultant	NTPC LIMITED							
PROJECT	2 X 800 MW NTPC LARA STPS STAGE-II SWITCHYARD							
NOA No.	CS-9587-001R-2-SCNOA- 7333 dtd 29.08.2023 CS-9587-001R-2-FCNOA- 7332 dtd 29.08.2023							
CONTENTS								
Section	Description					PAGES		
1	SCOPE, BILL OF QUANTITY, SPECIFIC TECHNICAL REQUIREMENT					5		
2	STANDARD TECHNICAL SPECIFICATION					NA		
3	ENCLOSURE TO SPECIFICATION:  (A) CUSTOMER TECHNICAL SPECIFICATION (B) PROJECT INFORMATION (C) TENDER DRAWINGS					77		
Rev No.	Date	Altered	Checked	Approved	REVISION DETAILS			
Distribution				To	TBEM	TBMM	TBQM	Vendor
				Copies	1	1	1	4

**PROJECT: 400kV Switchyard for LARA SUPER THERMAL POWER PROJECT (2x800MW)**  
**CUSTOMER: NTPC LTD.**

**Technical specification for Survey, Design & Engineering work for 400kv Transmission line**

**Section-1: Scope, Specific Technical Requirements & Quantities**

**TB-423-607-000-TL-PKG-I**  
**REV.00**

## **SECTION -1**

### **SCOPE, SPECIFIC TECHNICAL REQUIREMENT & QUANTITIES**

#### **1.0 INTRODUCTION**

- 1.1.0 The intent of this specification is to specify all details required by a Transmission Line survey and Geotechnical investigation for:
- 1.1.1 Conducting Transmission Line route survey, tower spotting/optimization of tower location, soil resistivity measurements and geotechnical investigation (as per NTPC specification enclosed), required for construction of transmission line project being executed by BHEL on turnkey basis for NTPC.
- 1.1.2 Quoting his most competitive rates for items indicated in Annexure-1 of this specification.
- 1.1.3 The above mentioned Transmission Line shall be interconnecting the AIS Extension of LARA STAGE-I (I-type configuration) to new AIS of LARA STAGE-II (D-type configuration) through 400kV Double Circuit line using Quad moose conductor.
- 1.1.4 For detailed technical specification for Survey & Geotechnical investigation, please refer Section-3 (NTPC specification).
- 1.1.5 For Project Details refer Section-3 attached.

#### **2.0 SCOPE**

- 2.1.0 The detailed scope of work under this specification is as following:
- 2.1.1 Carrying out preliminary/walkover survey using GPS and Topo sheets for the suggestive corridor/Right of way by NTPC (end-client) as per attached drawing at Annexure-2, suggesting best optimum alternative route (if required), identifying/fixing points for crossing such as river, railway, power line, telecom, road forest, identification of any existing structure to be dismantled, fixing of angle points & submission of preliminary survey report, profile plotting, sag template preparation, tower spotting, preliminary schedules (tower schedules indicating type of towers, extension, etc. inline with already available type tested tower design available with any power utility in India) & other detail preparations.

- 2.1.2 Detailed survey including modification in preliminary route alignment, adjustment in section details to achieve better average span, profiling, collecting actual field data along the selected route (enumeration of salient land features like crossing of rivers, nalla, road, railway lines, piping, other transmission/distribution line, nearby habitations, forest land, proximity to airport, etc.), tower spotting & **providing tower schedule (showing no & types of tower)** with detailed land schedule (Plot no/Khata no., etc) for each tower location, estimation of tower quantities with extension and special tower requirement, sag template, marking on Khasra map and topographical map, tree enumeration, etc. & submission of detailed survey report along with route profiling drawing, all complete as per technical specifications & directions of Engineering In-charge including its approval from BHEL/customer.
- 2.1.3 Carrying out check-survey for route alignment to locate and peg mark tower positions conforming to approved profile, tower schedule and technical specifications. Changes, if required in tower schedule after detailed survey, shall be carried out and thereafter submit revised tower schedule for approval. The tower schedule shall show co-ordinates of all towers, type of towers, span length, type of foundation for each tower and the deviation. (Check survey to be done jointly in presence of civil work agency finalised by BHEL)
- 2.1.4 Conducting detailed soil investigation at various tower locations and at other locations as necessary including mobilization of necessary equipment, providing necessary engineering supervision and technical personal, carrying out field investigation and tests, laboratory tests, analysis and interpretation of data and results, collecting data regarding change of course of rivers from local sources, velocity, scour, etc. giving floor details of the area (past history), preparations for the type of foundations, and safe bearing capacity for different size of foundations, different founding strata for the various locations along the transmission lines.
- 2.1.5 Conducting Electrical Resistivity Test of soil at various tower locations including submission of test report for approval of BHEL/Customer including mobilization of

necessary equipment, tools, manpower etc complete as per relevant IS Code, Technical specification and Instruction of Engineer-In-charge

2.1.6 Preparation of Bill of quantity in attached format at Annexure-1.

2.1.7 Design calculations, drawings & documents are required to be furnished after successful award of contract.

2.1.8 Getting all the works as mentioned above approved by BHEL/customer.

2.1.9 The Bidder shall depute his engineer(s) to Site or BHEL's/Customer's office/Supplier's works for any clarification etc. as required by BHEL/Customer. Bidder shall also depute his engineer(s) to site for check surveys also.

2.1.10 Preparation & submission of design documents of Transmission line, bill of material of hardware etc. The detailed design & drawing work shall include, but not limited to:

- Verification of all data, criteria and information contained in the contract documents.

- Generation of all data, criteria and information required for the completion of work including liaison and interface with BHEL/Customer/Customer's Engineer.

- Preparation of construction drawings with sufficient detailing so that no difficulty is faced by site engineers during execution.

2.1.11 Getting all the works mentioned above approved by BHEL/Customer's Engineer/Customer.

2.1.12 Preparation and submission including its approval from BHEL/Customer of the following drawing/documents:

(a) Bill of Material for transmission line material including conductor, conductor accessories, earthwire, ADSS Optical Fiber Cable, earth wire/OPGW accessories, ADSS Optical Fiber Cable accessories, stringing hardware, disc insulators etc

(b) Sag profile, Erection Key Diagram

- (c) Stringing chart of all spans for conductor, earth wire, ADSS cable etc., including damper placement chart as applicable.
- (d) Earthing details of Towers.
- (e) Design basis report of distribution line
- (f) Transmission Line geotechnical investigation report including resistivity report.
- (g) Transmission Line detailed route survey & check survey, tower spotting (preferably for Single type of tower for all locations with different leg extensions, etc based on requirement) & transmission line profile.
- (h) Any other drawing/documents required for successful completion of the work.

### 3.0 SPECIFIC TECHNICAL REQUIREMENTS

- 3.1.0 The specific technical requirements shall be as per project specific input provided by BHEL from time to time after award of work.
- 3.2.0 The Bidder shall interact closely with BHEL engineering group for any input/clarification and finalize details across the table. There may be certain cases when on account of revision or change of inputs, certain survey/ design / drawing may be required to be redone. **No claim on account of this shall be entertained.** Only suitable time extension shall be granted on account of above.
- 3.3.0 The bidder / representatives of bidder may be required to make several visits to site / BHEL office / customer's office depending upon the project requirements. **No extra claim on account of these visits shall be entertained.**

### 4.0 SCHEDULE/BOQ OF ITEMS

- 4.1.0 The Schedule/BOQ of Items shall be as per **Annexure 1**. The Bidder is required to quote his most competitive rate for these items.

### 5.0 DOCUMENTATION

- 5.1.0 All design documents including computer outputs shall be neatly typed, produced on A4 size paper and shall have a 'Cover Sheet' (To be provided later).

**PROJECT: 400kV Switchyard for LARA SUPER THERMAL POWER PROJECT (2x800MW)**  
**CUSTOMER: NTPC LTD.**

**Technical specification for Survey, Design & Engineering work for 400kv Transmission line**

**Section-1: Scope, Specific Technical Requirements & Quantities**

**TB-423-607-000-TL-PKG-I**  
**REV.00**

5.2.0 All drawings shall be prepared in AutoCAD as per standard sizes (viz. A0, A1, A2, A3 & A4) and shall have a 'Title Block' (To be provided later).

5.3.0 The number of copies of design documents & drawings required to be submitted shall be as follows:

At each stage of Submission/Revision (Soft Copy)

i) Reports/Design Documents 01 sets.

ii) Drawings (incl AutoCAD & pdf file) 01 sets.

#### **6.0 COMPLETION SCHEDULE:**

6.1.0 The work under this scope of work must be completed within 3 months after placement of order except check survey.

6.2.0 The check survey shall be done along with civil construction agency after finalization of civil construction agency by BHEL and intimation by Site in charge. Check survey should be completed within 2 Weeks including Check survey report.

#### **7.0 PAYMENT SCHEDULE:**

<b><u>Sl. No.</u></b>	<b><u>Condition</u></b>	<b><u>Payment</u></b>
1	After conducting survey/ investigation work, report preparation, submission and approval of reports/design documents/ drawings  (i) Cat 2 i.e approved with comments  (ii) Cat 1 i.e approved	80%  10%
2	After completion of activities under scope of works including check survey and BOM as per attached format in Annexure-B, approval of all drawings/documents in Cat-1, submission of all drg/documents.	Balance 10%

## BILL OF QUANTITIES AND PRICE SCHEDULE

**Project : 2X800MW LARA THERMAL POWER PLANT STAGE-II**

**Customer : NTPC Ltd.**

S. No.	Item / Work description	Unit	Quantity
<b>1</b>	<b>Reconnaissance &amp; Preliminary Survey</b>		
(a)	Conducting reconnaissance/walkover & preliminary survey using GPS and Topo sheets for the suggestive corridor/Right of way by NTPC (end-client) as per attached drawing at Annexure-2, suggesting best alternative route (if required), identifying/fixing points for crossing such as river, railway, power line, telecom, road forest, identification of any existing structure to be dismantled, fixing of angle points & submission of preliminary survey report all complete as per project specification & directions of BHEL including its approval from BHEL/customer	KM	1.2
<b>2</b>	<b>Detailed &amp; Check Survey</b>		
(a)	<p><b>Detailed Survey:</b> Detailed survey including modification in preliminary route alignment, adjustment in section details to achieve better average span, profiling, collecting actual field data along the selected route (enumeration of salient land features like crossing of rivers, nalla, road, railway lines, other transmission / distribution line, nearby habitations, forest land, proximity to airport, etc.), tower spotting &amp; providing tower schedule with detailed land schedule (Plot no./khata no., etc) for each tower location, estimation of tower quantities with extension and special tower requirement (if any), marking on khasra map and topographical sheets, detailed bill of quantity for transmission line material, sag template, tree enumeration, etc. &amp; submission of detailed survey report, including check survey all complete as per project specification &amp; directions of BHEL including its approval from BHEL/Customer.</p> <p>(Check survey to be done in liasoning with civil agency. All details in this regard to be issued to civil agency so that construction can be taken up)</p> <p>(a) 80% payment for completion of all activities except check survey (b) 20% payment after completion of check survey</p>	KM	1.2
(b)	<p><b>Check survey:</b> Survey for route alignment to locate and peg mark tower positions on ground conforming to approved profile and tower schedule. Changes, if required, after detailed survey in tower scheudle shall be carried out and thereafter submit tower schedule for approval. The tower schedule shall show position of all towers, type of towers, span length, type of foundation for each tower and the deviation. Check survey to be done in liasing with civil work agency finalised by BHEL (All details in this regard to be issued to civil agency so that construction can be taken up)</p>	KM	1.2
<b>3</b>	<b>Geotechnical investigation &amp; soil resistivity measurements</b>		
(a)	Conducting detailed soil investigation at various tower locations & other locations as per instructions of BHEL/customer including mobilization of necessary equipment, providing necessary engineering supervision and technical personnel, carrying out field investigations and tests, laboratory tests, analysis and interpretation of data and results and working out tentative quantity of foundation work, preparations for the type of foundation and the safe bearing capacity for different sizes of foundations, different foundation strata for various locations along the transmission line all complete, submission of report as per project specification & direction of BHEL including its approval from BHEL/customer	No	6
(b)	Performing soil resistivity along the route for each tower location and working out tentative quantity of earthing material all complete as per project specification & directions of BHEL including its approval from BHEL/customer	No	6
<b>4</b>	<b>Design and engineering - All Other Documents</b>		
	<p>Other documents: Preparation and submission including its approval from BHEL/Customer's Engineer/Customer of the following :</p> <p>(a) Bill of Material for transmission line material including conductor, conductor accessories, earthwire, ADSS Optical Fiber Cable, earth wire/OPGW accessories, ADSS Optical Fiber Cable accessories, stringing hardware, disc insulators etc</p> <p>(b) Sag profile/Erection Key Diagram of each line,</p> <p>(c) Stringing chart of all spans for conductor, earth wire, ADSS cable etc., including damper placement chart as applicable.</p> <p>(d) Earthing details of towers</p> <p>(e) Design basis report of transmission line</p> <p>(f) Any other drawing/documents required for successful completion of the work.</p>	Lot	1

Notes:	
1	Any material/services required for successful completion of the project but not covered in the BOQ shall be deemed to be included in the scope of contractor without any cost implications to BHEL. The bidder is advised to visit site before submission of bid.
2	The quantities mentioned in the BOQ are tentative and may undergo a change to any extent for individual items.
3	The bidder / representatives of bidder may be required to make several visits to site / BHEL office / customer's office depending upon the project requirements. No extra claim on account of these visits shall be entertained.
4	Site clearance, jungle clearing to make approach for survey work have be executed by bidder.
5	Cumulative length of transmission line route is considered approx. 1.2 km as per Annexure II. The final measurement for survey shall be of line route length irrespective of number of circuits.

**SECTION - 2**

**STANDARD TECHNICAL SPECIFICATION**

**(N.A.)**

**SECTION - 3**

**ENCLOSURES TO THE SPECIFICATION**

(A) CUSTOMER'S TECHNICAL SPECIFICATION

(B) PROJECT INFORMATION

(C) TENDER DRAWINGS

**TECHNICAL REQUIREMENTS**



	<p align="center"><b>TECHNICAL REQUIREMENTS</b></p> 
<p><b>11.00.00</b></p>	<p><b>400KV TRANSMISSION LINES – GENERAL</b></p>
<p>11.01.00</p>	<p><b>SCOPE AND GENERAL INFORMATION</b></p>
	<p>In addition to the project information and scope of work given in Part-A, of this specification, the following is the scope of work for overhead Transmission line work:</p>
<p>11.01.02</p>	<p>This specification covers detailed survey, tower spotting, optimization of tower location, soil resistivity measurements and geo-technical investigation, tower design, fabrication and supply of all types of transmission line towers including tower which are already designed and tested for equal or higher loads as specified in this specification, bolts, nuts and washers, hanger, D-shackle and all type of tower accessories like phase plate, number plate, danger plate, anti-climbing device, etc.; foundation design, selecting type of foundation for different towers and casting of foundation for towers and erection of towers, tack welding of bolts and nuts along with subsequent application of zinc coating on the welded portion, supply and application of zinc rich paint, tower earthing, fixing of insulator string, stringing of conductors and earth wires along with all necessary line accessories and testing and commissioning of the erected transmission lines.</p> <p>Further for type tested towers bidder shall furnish design calculation for transmission line tower structures along with foundation design and drawing meeting the requirements of this technical specification.</p>
<p>11.01.03</p>	<p>This specification includes the design and supply of insulator and their hardware conductor, OPGW and earthwire, earthwire suspension and tension clamps and all the other line accessories to be incorporated in the towers during erection and stringing.</p>
<p>11.01.04</p>	<p>All the raw materials such as steel, zinc for galvanising, reinforcement steel and cement for foundation, coke and salt for earthing, bird guards, anti climbing devices, bolts, nuts, washers, D-shackles, hangers, links, danger plates, phase plate, number plate etc. required for tower manufacture and erection shall be included in the scope of supply.</p>
<p>11.01.05</p>	<p>The entire stringing work of conductor and earthwire shall be carried out as per standard stringing practice.</p>
<p>11.01.06</p>	<p>The Contractor shall carry out the detailed survey and shall submit report/results for employer approval. No other details except those included in tender documents shall be furnished by the Owner. Also no topographical maps shall be furnished by Owner. However, Owner’s assistance may be given in obtaining these maps from Survey of India.</p>
<p>11.01.07</p>	<p>The tree-cutting shall be responsibility of the Contractor. The Contractor shall count, mark and put proper numbers with suitable quality of paint at his own cost on all the trees that are to be cut. Contractor may note that Owner shall not pay any compensation for any loss or damage to the properties or for tree cutting due to Contractor’s work.</p>

**TECHNICAL REQUIREMENTS**



<p><b>11.02.00</b></p> <p>11.02.01</p> <p>11.02.02</p> <p><b>11.03.00</b></p> <p>11.03.01</p> <p>11.03.02</p> <p><b>11.03.03</b></p>	<p align="center"><b>ROUTE AND TERRAIN</b></p> <p>Right of way and way leave clearance shall be arranged by the Owner.</p> <p>To evaluate and tabulate the trees and bushes coming within 26 meters on either side of the central line alignment, the trees will be numbered and marked with quality paint serially from angle point 1 onwards and the corresponding number will be painted on the stem of trees at a height of one meter from ground level. The trees list should contain the following:</p> <p>a) Girth (circumference) measured at a height of 1 meter from ground level.  b) Approximate height of the tree with an accuracy of + 2 meters.  c) Name of the type of the species/tree.  d) The bushy and under growth encountered in the 1.5 meters belt should also be evaluated with its type, height, girth and area in square meters, clearly indicating the growth in the tree/bush statement.</p> <p>Payment of compensation towards the clearances, etc. will be the responsibility of the Owner.</p> <p align="center"><b>DETAILED SURVEY</b></p> <p>The detailed survey shall be carried out along the Transmission Line alignment by successful bidder/contractor. The report shall be in line with CBIP-Manual-Transmission line -323 guidelines.</p> <p><b>Route Marking</b></p> <p>At the starting point of the commencement of route survey, an angle iron spike of 65 x 65 x 6 mm section and 1000 mm long shall be driven firmly into the ground to project only 150 mm above the ground level. A punch mark on the top section of the angle iron shall be made to indicate location of the survey instrument. Teak wood peg 50 x 50 x 650 mm size shall be driven at prominent position at intervals of not more than 750 meter along the transmission line to be surveyed upto the next angle point. Nails of 100 mm length should be fixed on the top of these pegs to show the location of instrument. The pegs shall be driven firmly into the ground to project 100 mm only above ground level. At angle position stone/concrete pillar with "NTPC" marked on them shall be put firmly on the ground for easy identification.</p> <p><b>Profile Plotting &amp; Tower Spotting</b></p> <p>From the field book entries the route plan with route details and level profile shall be plotted and prepared as per approved procedure. Reference levels at every 20 meters along the profile are also to be indicated on the profile besides R/Ls at undulations. Areas along the profile, which in the view of the Contractor are not suitable for tower spotting, shall also be clearly marked on the profile plots. If the</p>
--	---

difference in levels is too high, the chart may be broken up according to requirement. A 10mm overlap shall be shown on each following sheet. The chart shall progress from left to right. Sheet shall be in accordance with the IS Standard. For 'as built' profile these shall be A1 size.

11.03.04

**Sag Template**

Necessary data in respect of conductor, earthwire and insulator have been given in the specifications. On the basis of these, the Contractor shall prepare the sag template drawing and tower spotting data and submit the same alongwith sag tension calculations for the approval of the Owner. Sag template prepared based on the approved sag-template curve drawing shall only be used for tower spotting on the profiles. Two numbers of the approved template, prepared on rigid transparent plastic sheets, shall be provided by the Contractor to the Owner for the purpose of checking the tower spotting. The templates shall be on the same scale as that of the profile.

11.03.05

**Tower Spotting**

With the help of approved sag template and tower spotting data, tower locations shall be marked on the profiles. While locating the towers on the profile sheet, the following shall be borne in mind:

a) Span

The number of consecutive spans between the section points shall not exceed 15 spans Section point shall comprise of tension point with B type, C type or D Type towers as applicable. For all crossing spans such as major road crossings, railway crossings, power line crossings etc. the span shall not exceed 80% of design span.

b) Extension

An individual span shall be as near to the normal design span as far as possible. In case an individual span becomes too short with normal supports on account of undulations in ground profile, one or both the supports of the span may be extended by inserting standard body extension designed for the purpose according to technical specification.

c) Road Crossing

At all important road crossings, the towers shall be fitted with double tension insulator strings depending on the type of towers but the ground clearance at the roads under maximum temperature and in still air shall be such that even with conductor broken in adjacent span, ground clearance of the conductor from the road surfaces shall be in line with IE rules. At all national highway crossings, tensions towers shall be used.

d) Railways Crossings

## TECHNICAL REQUIREMENTS



i) At the time of detail survey all the railway crossings coming enroute the transmission line shall be finalised as per the regulation laid down by the Railway Authorities. The following are the important features of the prevailing regulations (revised in 1987):

ii) The crossing shall be supported on D type tower on either side of railway line with double tension insulator strings.

iii) The crossing shall normally be at right angle to the railway track.

iv) The crossing span shall be limited to 80% of design span.

v) The minimum distance of the crossing tower shall be at least equal to the height of the tower plus 6 meters away measured from the centre of the nearest railway track.

vi) No crossing shall be located over a booster transformer, traction switching station, traction sub-station or a track cabin location in an electrified area.

vii) Minimum ground clearance above rail level of the lowest portion of any conductor under condition of maximum sag shall be maintained as per IE rules.

viii) The approval for crossing railway track shall be obtained by the Owner from the Railway Authority. However, six copies of profile and plan, tower and foundation design and drawings, required for the approval from the Railway Authority shall be supplied by the Contractor to the Owner.

### e) River Crossings

In case of major river crossing, towers shall be of suspension type and the anchor towers on either side of the main river crossing shall be C type tower. Clearance required by navigation authority shall be provided. For non navigable river, clearance shall be reckoned with respect to highest flood level (HFL).

### f) Power Line Crossing

Where this line is to cross over another line of the same voltage or lower voltage, towers with suitable extension shall be used. Provisions to prevent the possibility of its coming into contact with other overhead lines shall be made in accordance with the Indian Electricity Rules, 1956. The Contractor may be required to under-cross higher voltage lines by erecting gantry structures.

### g) Telecommunication Line Crossing

The angle of crossing shall be as near 90 degree as possible. However, deviation to the extent of 30 degree may be permitted under exceptionally difficult situations. When the angle of crossing has to be below 60 degree, the matter will be referred to the authority incharge of the telecommunication system. On a request from the Contractor, the permission of the telecommunication authority may be obtained by the Owner. Also, in the crossing span power line support will be as near the

**TECHNICAL REQUIREMENTS**



	<p align="center"><b>TECHNICAL REQUIREMENTS</b></p> 										
<p>11.03.06</p>	<p>telecommunication line as possible, to obtain increased vertical clearance between the wires.</p> <p>h) Details Enroute</p> <p>All topographical details, permanent features, such as trees, building etc. 13.5m on either side of the alignment shall be detailed on the profile plan.</p> <p>i) Ash Pipe Line (If applicable)</p> <p>Adequate clearances shall be maintained from ash pipe line and adjacent road.</p> <p><b>Clearance from Ground, Building, Trees, etc.</b></p> <p>Clearance from ground, buildings, trees and telephone lines shall be provided in conformity with the Indian Electricity Rules, 1956 as amended upto date.</p>										
<p>11.04.00</p>	<p><b>PRELIMINARY LINE SCHEDULE</b></p> <p>The profile sheets, duly spotted, alongwith preliminary schedules indicating type of towers, wind span, weight span, angle of deviation, river, power line, railway or road crossing and other details shall be submitted for the approval of the Owner. After approval, the Contractor shall submit six more sets of the approved reports along with two sets in soft copy of final profile drawings to the Owner for record purpose.</p>										
<p>11.05.00</p>	<p><b>CHECK SURVEY OF TOWER LOCATIONS</b></p>										
<p>11.05.01</p>	<p>The detailed survey shall be conducted to locate and peg mark the tower positions on ground conforming to the approved profile and tower schedule. In the process, it is necessary to have the pit centers marked according to the excavation marking charts. The levels, up or down of each pit center with respect to the center of the tower locations shall be noted and recorded for determining the amount of earthwork required to meet the approved design parameters.</p>										
<p>11.05.02</p>	<p>Changes, if required, after detailed survey in the preliminary tower schedule shall be carried out by the Contractor and he shall thereafter submit a final tower schedule for the approval of Owner. The tower schedule shall show position of all towers, type of towers, span length, type of foundation for each tower and the deviation at all angles as set out with other details.</p>										
<p>11.06.00</p>	<p><b>ELECTRICAL SYSTEM DATA</b></p> <table border="0"> <tr> <td>Nominal voltage</td> <td>400 kV</td> </tr> <tr> <td>Maximum system voltage</td> <td>420kV</td> </tr> <tr> <td>Lighting Impulse</td> <td>1425 kVp</td> </tr> <tr> <td>Switching Impulse</td> <td>1050KVp</td> </tr> <tr> <td>Power frequency withstand voltage (wet)</td> <td>630 kV (rms)</td> </tr> </table>	Nominal voltage	400 kV	Maximum system voltage	420kV	Lighting Impulse	1425 kVp	Switching Impulse	1050KVp	Power frequency withstand voltage (wet)	630 kV (rms)
Nominal voltage	400 kV										
Maximum system voltage	420kV										
Lighting Impulse	1425 kVp										
Switching Impulse	1050KVp										
Power frequency withstand voltage (wet)	630 kV (rms)										

**TECHNICAL REQUIREMENTS**



**LIST OF STANDARDS**

1.	IS:209	Specification for Zinc	ISO/R/752-1968 AST, B6
2.	IS:2062	Structural Steel (Standard Quality)	ISO/R/6F30-1967 CAN/CSA G40.21 BS 4360
3.	IS:269	Ordinary rapid hardening & low heat Portland Cement.	ISO/R/597-1967
4.	IS:278	Specification for barbed wire	ASTM A 121
5.	IS:383	Coarse and fine aggregates from natural sources for concrete.	CSA A 23.1/A 23.2
6.	IS:398	Alum. Condr. galvanised steel reinforced	
7.	IS:406	Methods of Chemical Analysis of Slab Zinc	
8.	IS:432 (Part 1 & 2)	Mild steel and medium tensile bars and hard drawn steel wire for concrete reinforcement	CSA-G-30
9.	IS:456-1978	Code of practice for plan and reinforced concrete	
10.	IS:731-1971	Porcelain Insulators for Overhead Power lines with a Nominal Voltage greater than 1000 volts	BS:137-1973 (I & II) IEC:274-1968 IEC:383-1976
11.	IS:800-1984	Code of practice for use of structural steel in general Building construction	CSA STEAM 16.1
12.	IS:802	Code of practice for use of structural steel in overhead transmission Line. (Load, Permissible stresses. Fabrication, Galvanising, Inspection, and Packing and Testing)	IEC 826 ASCE 52 BS 8100
13.	IS:1139-1966	Hot rolled mild steel medium tensile steel and high yield strength deformed Bars for concrete reinforcement	CAN / CSA G 30 18
14.	IS:1367-1967	Technical supply conditions for threaded fasteners	
15.	IS:1489-1991	Portland Pozzolena Cement	ISO/863-1968

**TECHNICAL REQUIREMENTS**



16.	IS:1521-1972	Method of Tensile Testing of Steel wire	
17.	IS:1573-1976	Electroplated Coating of Zinc on Iron & Steel	
18.	IS:1778-1980	Reels and Drums of Barewire	
19.	IS:1786-1985	High strength deformed steel bars and wires for concrete reinforcement	
20.	IS:1893-1984	Criteria of Earthquake resistant design of structures.	IEEE 693
21.	IS:2016-1967	Plain Washers	ISO/R/887-1968 ANSI B 18.22.1
22.	IS:2070- 1962	Method of impulse voltage testing	
23.	IS:2071	Method of high voltage testing	
24.	IS:2121-1981	Specification for conductors and earthwire Accessories for Overhead Power Lines Part-I Armour Rods Part-II Mid-span joints & repair sleeves for conductors	
25.	IS:2131-1967	Method of Standard penetration test for soils.	ASTM D 1883
26.	IS:2551-1982	Danger Notice Plates	
27.	IS:2486	Specification for Insulator Fittings for overhead Power Lines with a nominal voltage greater than 1000 volts Part- I General Requirements and Tests Part-II Dimensional Requirements Part-III Locking Devices	BS:3288-1972 IEC:120-1960 IEC:372-1976
28.	IS:2629-1985	Recommended practice for hot dip galvanising of iron & steel.	ASTM A 123 CAN/CSA G 164
29.	IS:2633-1986	Method of testing uniformity of coating of zinc coated articles.	ASTM A 123 CAN/CSA G 164
30.	IS:3043-1987	Code of Practice for earthing (with amendment No. 1 & 2).	
31.	IS:3063-1994	Single Coil Rectangular Section spring	DIN - 127-1970

**TECHNICAL REQUIREMENTS**



		washers for bolts, nuts, screws.	
32.	IS:3138-1966	Hexagonal bolts and nuts	ISO/R 947 and ISO/R 272
33.	IS:3188-1980	Characteristics of string insulator units	IEC:305-1906
34.	IS:4091-1979	Code of practice for design and construction of foundation for transmission line tower and poles.	ASCE / IEEE 691
35.	IS:4218-1976	Metric Screw Threads.	ISO:68-1969 R-26-1963, R-262-1969 R-965-1965
36.	IS:4826-1979	Galvanised coatings on round steel wire	BS:443-1969
37.	IS:5300-1980	Porcelain Guy strain insulators	
38.	IS:5358-1969	Hot dip galvanised coatings on fasteners	ASTM A 153 CAN/CSA G 164
39.	IS:5613 (Part-II) 1985	Code of practice for Design, installation & maintenance of overhead power lines	
40.	IS:6610-1972	Specification for heavy washers for steel structures.	
41.	IS:6639 -1972	Hexagonal bolts for structure	ASTM A 394 CSA B 33.4
42.	IS:6745-1972	Methods for determination of weight of Zinc coated iron and steel articles	ASTM A 90
43.	Pub. No. 19 (N)/ 700-1963	Regulation for Electrical Crossing of Railway Tracks.	
44.	IS:7814-1985	Phosphor bronze sheet, strip and foil	BS:2870-1968
45.	IS:8263-1976	Method of Radio Interference tests on high voltage insulators	NEEMA:107 – 1964 CISPR/IEC:437-1973
46.	IS:8269-1976	Method of switching impulse test on high voltage insulators	IEC:506-1975
47.	IS:8500-1991	Specification for weld-able structural steel (Medium and High strength qualities).	BS : 4360

**TECHNICAL REQUIREMENTS**



- 48. IS:9708-1993 Specifications for Stockbridge Vibration Dampers for overhead power lines
- 49. Thermal mechanical performance test and mechanical performance test on String insulator units IEC: 575-1974

**12.00.00 GENERAL DESCRIPTION OF TOWERS**

- 12.01.01 The towers shall be of self supporting lattice steel type, designed to carry the line conductors with necessary insulators, earth wires and all fittings under all loading conditions.
- 12.01.02 The tower shall be of a fully galvanised structure, using structural mild steel sections for members. Bolts and nuts with spring washers shall be used for connections.
- 12.01.03 Bidders can also use high tensile steel and cold formed steel for fabrication of towers provided they furnish the justification for use of such steel with reference to national or international standards. However, the factors of safety, limitation on member length, requirement of fasteners and galvanisation shall be as specified in this specification.

The towers shall be classified as given in Table -1

**Table T-1**

Type of Tower	Deviation limit (Degrees)	Typical use
A	0 to 2	To be used as tangent/suspension tower
B	0 to 15	a) Angle towers/Tension tower with tension insulator string. b) To be used where the towers are subject to uplift loads. c) To be used as section tower
	0	
C	15 to 30	a) Angle tower/Tension tower with tension insulator string b) To be used where the towers are subject to uplift loads. c) To be used as section tower
	NA	d) Complete dead end. (for 33kV line only)
D	30 to 60	a) Angle tower/Tension tower with tension insulator string b) To be used where the towers are subject to uplift loads.

## TECHNICAL REQUIREMENTS



		c) To be used as section tower
	0	d) Complete dead end.

**NOTE:**

- 1) For double circuit tower types, A, B, C and D shall be prefixed by 'D'.
- 2) Special type of tower/ higher voltage class towers, wherever required shall also be provided by the bidder under the contract at no extra cost.

12.01.04

**Extension**

The single and double circuit tower shall be designed with 9 M body extension so as to be suitable for adding 3M, 6M and 9M body extension. In case of requirement of higher body extensions, the tower shall be designed for the highest extension required.

For under line crossing of EHV transmission lines the bidder extensions to D type tower or provide tower-gantry arrangement.

12.01.05

**Stub Setting templates.**

Stub templates shall be designed and arranged by the contractor at his own cost for all types of tower with or without extension and also for leg extension. Stub templates for standard towers and tower with extension shall be of adjustable type. The stub templates shall be painted. One set of each type of stub setting template for single and double circuit tower shall be supplied to the Owner, on completion of the project, at no extra cost.

12.02.00

**SPANS AND CLEARANCES**

12.02.01

**Ruling Span**

The normal ruling span of the line shall be 400 meters for 400 KV towers.

12.02.02

**Wind Span**

The wind span is the sum of the two half spans adjacent to the support under consideration. For normal horizontal spans this equals to normal ruling span.

12.02.03

**Weight Span**

The weight span is the horizontal distance between lowest point of the conductors on the two spans adjacent to the tower. For design of structures, the span limits given below shall prevail.

Tower type	Normal Condition		Broken Wire Condition	
	Max. (m)	Min. (m)	Max. (m)	Min. (m)
A,	600	-200	360	-100
B, C	600	0	360	-200
D	600	0	360	-300

## TECHNICAL REQUIREMENTS



12.02.04

Electrical Clearance

### A) Ground clearance

The minimum ground clearance from the bottom conductor shall be as per IE rules at the maximum sag conditions i.e. at maximum temperature and still air. However, to achieve the above clearance the height of tower shall be increased in the following manner:

- a) Allowance of 150 mm shall be provided to account for errors in stringing.
- b) Conductor creep shall be compensated by over tensioning the conductor at a temperature lower than the ambient temperature. The creep correction temperature along with calculations shall be furnished by the Contractor.
- c) Minimum spacing  
The minimum electrical clearance between conductors shall be as per relevant standards.

### B) Rail Crossing

In case of rail crossing the min. height above rail level of the lowest portion of any conductor under condition of max. sag, in accordance with the regulations for Electrical Crossing of Railway tracks as prevailing at the time of construction of line shall be applicable.

### C) Power Line Crossing

Minimum clearance between power line to power line crossing shall be as per IE rules.

### D) Live Metal Clearance

The minimum live metal clearance to be provided between the live parts and steel work of super-structure shall be as per relevant standards.

NOTE:

- i) Bidder shall adopt same cross arm design where jumper is projecting outside of cross-arm for 'D' type tower to be used as dead end and angle tower.
- ii) The design of the tower shall be such that it will satisfy all the conditions when clearances are measured from any live point of the strings.

### E) Angle of Shielding

The angle of shielding is defined as the angle formed by the line joining the center lines of the earthwire and outer power conductor, in still air, at tower supports, to the vertical line through the center line of the earthwire. Bidders shall design the tower in such a way that the angle of shielding does not exceed 30 deg for double circuit tower. The drop of the earthwire clamp, which is in the scope of contractor supplied items, should be considered while calculating the minimum angle of protection. For estimating the minimum angle of protection the drop of earth wire suspension clamp alongwith shackle shall be taken as 150mm.

**TECHNICAL REQUIREMENTS**



**F) Mid Span Clearance**

The minimum vertical mid span clearance between the earthwire and the nearest power conductor shall be as per IE/relevant rules, which shall mean the vertical clearance between earthwire and the nearest conductor under all temperatures and still air condition in the normal ruling span. Further, the tensions of the earthwires and power conductors, shall be so co-ordinated that the sag of earthwires shall be at least 10% less than that of power conductors under all temperature loading conditions.

**12.03.00 LOADING CONDITIONS**

**12.03.01 Loads at Conductor And Earthwire Points**

Contractor shall consider the ultimate external loadings at conductor and earthwire points base on IS 802-1, 1995. The Contractor shall develop the tower designs considering these loadings. The towers are to be designed to cater for the following loads:

- a) Reliability Loads (Normal condition)
- b) Security Loads (Broken wire condition)
- c) Safety Loads (Construction & Maintenance loads)

**12.03.02 Suspension towers shall be designed for full wind load under security condition**

**Wind Loads on Tower Body**

The wind load on tower body shall be calculated by the Contractor as per IS:802, Part-I, 1995.

**12.03.03 Maximum Tension**

Maximum tension shall be based on either of the following (whichever is more stringent):

- a) at 0 deg C with 36% full wind pressure., or
- b) at 32 deg C with full wind pressure

The value of drag co-efficient (Cd) shall be 1.2 for conductor/earthwire if the diameter of the conductor/earth is 15mm or less.

12.03.04 Sag tension calculation for design purpose shall be calculated considering normal ruling span.

12.03.05 The initial conductor and earthwire tension at 32 degree C and without wind shall be 22% of the ultimate tensile strength of the conductor and 20% of the ultimate tensile strength of the Earthwire.

**12.03.06 Limiting Tensions of conductor & Earthwire**

The ultimate tension of conductor and ground wire shall not exceed 70 per cent of the ultimate tensile strengths.

**12.03.07 Broken Wire Condition**

## TECHNICAL REQUIREMENTS



	<h2 style="margin: 0;">TECHNICAL REQUIREMENTS</h2>																
12.03.08	<p>The loads for broken wire conditions shall be considered as per clause 16 of IS 802 (Part I/ Sec 1): 1995. The tower type B &amp; C shall be considered as small and medium angle towers whereas tower type D shall be considered as large angle tension tower/ dead end tower.</p> <p><b>Design Loads</b></p> <p>Owner's requirement for most stringent design longitudinal and transverse loads is summarized in Table T1-2.</p>																
12.04.00	<p><b>DESIGN OF TOWERS</b></p>																
12.04.01	<p><b>Design Criteria</b></p> <p>Towers shall be designed based on spans and clearances, and loading conditions as detailed above.</p>																
12.04.02	<p><b>Design Temperatures</b></p> <p>The following temperature range for the conductors and ground wires shall be adopted for line design:</p> <table style="width: 100%; border: none;"> <tr> <td style="width: 5%;">a)</td> <td style="width: 75%;">Minimum temperature</td> <td style="width: 5%;">:</td> <td style="width: 15%;">0 deg.C</td> </tr> <tr> <td>b)</td> <td>Everyday temperature of conductor</td> <td>:</td> <td>32 deg.C</td> </tr> <tr> <td>c)</td> <td>Max. temperature of Conductor</td> <td>:</td> <td>75 deg.C</td> </tr> <tr> <td>d)</td> <td>Max. temperature of Earthwire exposed to sun</td> <td>:</td> <td>53 deg.C</td> </tr> </table>	a)	Minimum temperature	:	0 deg.C	b)	Everyday temperature of conductor	:	32 deg.C	c)	Max. temperature of Conductor	:	75 deg.C	d)	Max. temperature of Earthwire exposed to sun	:	53 deg.C
a)	Minimum temperature	:	0 deg.C														
b)	Everyday temperature of conductor	:	32 deg.C														
c)	Max. temperature of Conductor	:	75 deg.C														
d)	Max. temperature of Earthwire exposed to sun	:	53 deg.C														
12.04.03	<p><b>Redundant Design</b></p> <p>All redundants in the towers are to be triangulated. Redundants, having an angle of 15 deg or less with horizontal are to be designed for a concentric vertical ultimate load of 1.5 KN acting at center of the unsupported length. The Contractor has to furnish the calculation for the same. The redundants shall also be designed for 2.5% of max. axial load of connecting members (i.e. leg members, bracing members etc.).</p>																
12.04.04	<p><b>Steel Sections</b></p> <p>For designing of towers, preferably rationalised steel sections shall be used. During execution of the project, if any particular section is not available same shall be substituted by higher section at no extra cost to Owner and the same shall be borne by the Contractor. However, design approval for such substitution shall be obtained from the Owner before any substitution.</p>																
12.04.05	<p><b>Thickness of Members</b></p> <p>The minimum thickness of angle sections used in the design of tower, unless otherwise specified elsewhere in this Specification, shall be kept not less than the following values:</p> <table style="width: 100%; border: none;"> <tr> <td style="width: 5%;">a)</td> <td style="width: 95%;">Main corner leg members including the groundwire peak and main cross arm : 5 mm</td> </tr> <tr> <td>b)</td> <td>For all other members : 4 mm</td> </tr> </table>	a)	Main corner leg members including the groundwire peak and main cross arm : 5 mm	b)	For all other members : 4 mm												
a)	Main corner leg members including the groundwire peak and main cross arm : 5 mm																
b)	For all other members : 4 mm																
12.04.06	<p><b>Bolts &amp; Nuts</b></p> <p>A) The minimum bolt spacing and rolled edge distance and sheared edge distance from the centers of the bolt holes to be maintained are given below:</p>																

## TECHNICAL REQUIREMENTS



- |    |                            |         |
|----|----------------------------|---------|
| a) | Diameter of bolts          | 16 mm   |
| b) | Hole diameter              | 17.5 mm |
| c) | Min. bolt spacing          | 40 mm   |
| d) | Min. rolled distance       | 20 mm   |
| e) | Min. sheared edge distance | 23 mm   |

B) Bolts sizes mentioned above shall only be used. The minimum width of the flanges without bolt holes shall be 30mm.

C) For the purpose of calculating shearing stress and bearing stress for bolts, IS:802-Part-II-1993 may be referred.

12.04.07 **Slenderness Ratio**

A) Slenderness ratio for members shall be computed in accordance with IS:802, Part-II, 1993. Slenderness ratio for compression and tension members shall not exceed the values specified therein.

B) The following maximum limit of the slenderness ratio i.e. the ratio of unsupported length of the section in any plane to the appropriate radius of gyration will be adopted:

- |    |   |     |
|----|---|-----|
| a) | For main corner leg members including the corner members of earthwire peak and the lower corner members of the cross-arms | 120 |
| b) | For other members having calculated stresses  | 200 |
| c) | For redundant members   | 250 |
| d) | For members having tensile stress only  | 400 |

C) The bracing pattern, including that of secondary bracings (redundants) shall be identical on transverse and longitudinal faces of the tower, i.e. staggering of primary and secondary bracings are not permitted. Primary bracings and redundants shall be properly triangulated, i.e. the overall pattern of bracing on tower body and cross arms shall be triangulated only.

12.04.08 **Erection Stress**

Where erection stress combined with other permissible co-existent stresses could produce a working stress in any member appreciably above the specified working stress, such other provisions are to be made as may be necessary to bring the working stress within the specified limit.

12.05.00 **TOWER MATERIALS**

12.05.01 **Tower Steel Sections**

IS steel sections of tested quality in conformity with IS: 2062 are to be used in towers, extensions and stub setting templates. No individual member shall be longer than 6000mm. The Bidder can also use most efficient grades of structural steel angle sections and plates conforming to latest international standards. However, the Bidders are permitted to opt for not more than two (2) grades of steel for any particular package.

## TECHNICAL REQUIREMENTS



	<h2 style="margin: 0;">TECHNICAL REQUIREMENTS</h2>
12.05.02	<p><b>Fasteners: Bolts, Nuts and Washers</b></p> <p>A) All bolts and nuts shall conform to IS: 6639. All bolts and nuts shall be galvanised and shall have hexagonal head and nuts, the heads being forged out of the solid, truly concentric, and square with the shank, which must be perfectly straight.</p> <p>B) The bolt shall be of 16 mm dia and of property class 5.6 as specified in IS:1367 (Part-III) 1979 and matching nut of property class as specified in IS:1367 (Part-VI).</p> <p>C) Bolts upto M16 and having length upto 10 times the diameter of the bolt should be manufactured by cold forging and thread rolling process to obtain good and reliable mechanical properties and effective dimensional control. The shear strength of bolts for 5.6 grade should be 310 MP a minimum as per IS:12427. Bolts should be provided with washer face in accordance with IS:1363 Part-I to ensure proper bearing.</p> <p>D) To ensure uniformity of galvanizing, bolts and nuts should be galvanised by high temperature hot-dip galvanizing.</p> <p>E) Nuts should be double chamfered as per the requirement of IS:1363 Part-III. It should be ensured by the manufacturer that nuts should not be overtapped beyond 0.4 MM oversize on effective diameter for size upto M16.</p> <p>F) Fully threaded bolts shall not be used. The length of bolts shall be such that the threaded portion will not extend into the place of contact of the members.</p> <p>G) All bolts shall be threaded to take the full depth of the nuts and threaded enough to permit firm gripping of the members, but not further. It shall be ensured that the threaded portion of each bolt protrudes not less than 3 mm and not more than 8mm when fully tightened. All nuts shall fit and tight to the point where the shank of the bolt connects to the head.</p> <p>H) Flat and tapered washers shall be provided wherever necessary. Spring washers shall be provided for insertion under all nuts. These washers shall be of steel electro-galvanised, positive lock type and 3.5mm in thickness for 16mm dia.</p> <p>I) The Bidder shall furnish bolt schedules giving thickness of members connected, the nut and the washer and the length of shank and the threaded portion bolts and sizes of holes and any other special details of this nature.</p> <p>J) To obviate bending stress in bolts or to reduce to minimum, no bolt shall connect aggregate thickness of more than three (3) times its diameter.</p> <p>K) The bolt positions in assembled towers shall be as per IS:5613 (Part-II/Section-2).</p> <p>L) Bolts at the joints shall be so staggered that nuts may be tightened with spanners without fouling.</p>
12.06.00	<p><b>Tower Accessories</b></p>
12.06.01	<p><b>Step Bolts &amp; ladders</b></p>

## TECHNICAL REQUIREMENTS



Each tower shall be provided with step bolts of not less than 16mm diameter and 175 mm long, spaced not more than 450mm apart and extending from about 3.5 meters above the ground level to the top of the tower. Step bolt shall be provided with two nuts on one end to fasten the bolt securely to the tower and button head at the other end to prevent the feet from slipping away. The step bolts shall be capable of withstanding a vertical load not less than 1.5 KN. For special structures, where the height of the super structure exceeds 50 meters, ladders along with protection rings shall be provided in continuation of the step bolts on one face of the tower from 30 meters above ground level to the top of the special structure. From 3.5 m to 30 m height of super structure step bolts shall be provided. Suitable railing for access from step bolts to the ladder and from the ladder to each cross arm tip and the groundwire support shall be fixed on tower by using countersunk bolts.

12.06.02 **Insulator Strings and Earthwire Clamps Attachments**

- a) For the attachment of suspension insulator string a suitable dimensioned swinging hanger on the tower shall be provided so as to obtain requisite clearance under extreme swinging conditions and free from swinging of the string. The hanger shall be designed to withstand an UTS equivalent to that of insulators. The supply of design & supply of hanger is in the scope of the Contractor.
- b) At tension towers strain plates of suitable dimensions on the underside of each cross-arm tip and at the top of earthwire peak, suitable plate should be provided for taking the hooks or D-Shackle of the tension insulator strings or earthwire tension clamps, as the case may be. Full details of the attachments shall be submitted by the bidder for Owner's approval before starting the mass fabrication.

12.06.03 Earthwire peaks/crossarms are to be suitably designed to accommodate the shackle of the suspension clamp/tension clamps.

12.06.04 **Anti-climbing Device**

Barbed wire type anti-climbing device shall be provided and installed by the Contractor for all towers. The height of the anti-climbing device should be provided approximately 3m above ground level. The barbed wire shall conform to IS-278-1978. The barbed wires shall be given chromating dip as per procedure laid down in IS:1340-1959.

12.06.05 Danger plate, Number plates, Circuit Plate, Phase plate & Bird Guards.

Danger, Number Plates, Phase Plates & Bird Guards shall be provided and installed by the Contractor:

- a) Each tower shall be fitted with a number plate, and danger plate. Each tension tower shall be provided with a set of phase plates also. The arrangement for fixing these accessories shall not be more than 4.5m above the ground level.
- b) The letters, figures and the conventional skull and bones of data plates shall conform to IS:2551-1963 and shall be in a single red on the front of the plate.
- c) The corners of the number and danger plate shall be rounded off to remove sharp edges.
- d) To prevent birds from perching immediately above the suspension insulator strings and thus fouling it with droppings suitable birdguards shall be provided at cross arm tips of all suspension towers. The arrangement shall conform to IS:5613 part-2/Sec.I.

12.07.00 **TOWER FABRICATION**

LARA THERMAL POWER PROJECT STAGE- II (2X800 MW) EPC PACKAGE	TECHNICAL SPECIFICATION SECTION – VI, PART-B	SUB-SECTION : <b>B-17: SWITCHYARD</b>	Page <b>63 of 97</b>
---	---	--	-------------------------

## TECHNICAL REQUIREMENTS



	<h2 style="margin: 0;">TECHNICAL REQUIREMENTS</h2>
<p>12.07.01</p> <p>12.07.02</p> <p>12.07.03</p> <p>12.07.04</p> <p>12.07.05</p> <p>12.07.06</p> <p>12.07.07</p> <p>12.07.08</p> <p>12.07.09</p> <p>12.07.10</p> <p>A)</p> <p>B)</p> <p>a)</p> <p>b)</p> <p>c)</p>	<p>Except where hereinafter modified, details of fabrication shall conform to IS:802 (Part-II) or the relevant international standards.</p> <p>Butt splices shall be used and the inside Angle and outside plate shall be designed to transmit the load and inside cleat angle, shall not be less than half the thickness of the heavier member connected plus 2mm. Lap splice may be used for connecting members of unequal size and the inside angle of lap splice shall be rounded at the heel to fit the fillet of the outside angle. All splices shall develop full stress in the member connected through bolts. Butt as well as lap splice shall be made as above and as close to the main panel point as possible.</p> <p>Joints shall be so designed as to avoid eccentricity as far as possible. The use of gusset plates for joining tower members shall be avoided as far as possible. However, where the connections are such that the elimination of the gusset plates would result in eccentric joints, gussets plates and spacer plates may be used in conformity with modern practices. The thickness of the gusset plates required to transmit stress shall not be less than that of members connected.</p> <p>The use of filler in connection shall be avoided as far as possible. The diagonal web members in tension may be connected entirely to the gusset plate wherever necessary to avoid the use of filler and it shall be connected at the point of intersection by one or more bolts.</p> <p>The tower structures shall be accurately fabricated to connect together easily at site without any undue strain on the bolts.</p> <p>No angle member shall have the two leg flanges brought together by closing angle.</p> <p>The diameter of the hole shall be equal to the diameter of bolt plus 1.5mm.</p> <p>The structure shall be designed so that all parts shall be accessible for inspection and cleaning. Drain holes shall be provided at all points where pockets depression are likely to hold water.</p> <p>All similar parts shall be made strictly inter-changeable. All steel sections before any work is done on them, shall be carefully leveled, straightened and made true to detailed drawings by methods which will not injure the materials so that when assembled, the adjacent matching surfaces are in close contact through out. No rough edges shall be permitted in the entire structure.</p> <p><b>Drilling and Punching</b></p> <p>Before any cutting work is started all steel sections shall be carefully straightened and trued by pressure and not by hammering. They shall again be trued after being punched and drilled.</p> <p>Holes for bolts shall be drilled on punched with a jig but drilled holes shall be preferred. The following maximum tolerance of accuracy of punched holes is permissible.</p> <p>Holes must be perfectly circular and no tolerance in this respect permissible.</p> <p>The max. allowable difference in diameter of the holes on the two sides of plates or angle is 0.8mm. i.e. the allowable taper in a punched holes should not exceed 0.8mm on diameter.</p> <p>Holes must be square with the plates or angles and have their walls parallel.</p>

## TECHNICAL REQUIREMENTS



C)	All burrs left by drills or punch shall be removed completely. When the tower members are in position the holes shall be truly opposite to each other. Drilling or reaming to enlarge holes shall not be permitted.
12.07.11	<b>Erection mark</b>
A)	Each individual member shall have erection mark conforming to the component number given to it in the fabrication drawings. This mark shall be marked with marking dies of 16mm size before galvanising and shall be legible after galvanising.
B)	Erection Mark shall be "A - BB- CC – DDD", where  A = Owner's code assigned to the Contractor Alphabet. BB = Contractor's Mark-Numerical CC = Tower Type-Alphabet DDD = Number mark to be assigned by Contractor.
12.07.12	<b>Quantities and Weights</b>
A)	The unit weight of each type of tower, stubs and extensions shall be furnished by the bidder. The weight of tower shall mean the weight of tower calculated by using the black sectional (i.e. un-galvanised) weight of steel members of the size indicated in the approved fabrication drawings and bills of materials, without taking into consideration the reduction in weights, holes, notches and bevel cuts etc, but taking into consideration the weight of the fasteners, anti-climbing devices etc.
12.07.13	<b>Galvanising</b>
	Fully galvanised towers and stub shall be used for the line. Galvanisation of the member of the towers shall conform to IS:2629 and IS:4759. The minimum weight of galvanisation shall be 610 gms/sqm. The galvanisation shall be done after all fabrication work is completed, except that the nuts may be tapped or re-run after galvanising. Threads of bolts and nuts shall have a neat fit and shall be such that they can be turned with finger throughout the length of the threads of bolts and they shall be capable of developing full strength of the bolts. Spring washers shall be electro-galvanised as per Grade 4 of IS:1573.
12.07.14	<b>TOWER EARTHING</b>
	The footing resistance of all towers shall be measured by the Contractor in dry weather after tower erection but before the stringing of earthwire. All the tower are to be earthed. In no case tower footing resistance shall exceed 10 ohms. Pipe type earthing and counterpoise type earthing wherever required shall be provided in accordance with the stipulations made in IS:3043-1987 and IS:5613 (part-II/Section-2) 1985. The details for pipe and counterpoise type earthing are given in drawing enclosed with the specification.
12.08.00	<b>INSPECTION AND TESTS</b>
12.08.01	All standard tests, including quality control tests, in accordance with appropriate Indian/International standard, shall be carried out unless otherwise specified herein.
12.08.02	<b>Inspection</b>

## TECHNICAL REQUIREMENTS



In addition to the provisions as specified elsewhere in this specification, the following shall also apply:

- A) The Contractor shall keep the Owner informed in advance about the time of starting and the progress of manufacture and fabrication of various tower parts at various stages, so that arrangements could be made for inspection.
- B) The acceptance of any part of items shall in no way relieve the Contractor of any part of his responsibility for meeting all the requirements of the Specification.
- C) The Owner or his representative shall have free access at all reasonable times to those parts of the Contractor's works which are concerned with the fabrication of the Owner's material for satisfying himself that the fabrication is being done in accordance with the provisions of the specifications.
- D) Unless specified otherwise inspection shall be made at the place of manufacture prior to dispatch and shall be conducted so as not to interfere unnecessarily with the operation of the work.
- E) Should any member of the structure be found not to comply with the approved design, it shall be liable to rejection. No member once rejected shall be resubmitted for inspection, except in cases where the Owner or his authorised representative considers that the defects can be rectified.
- F) Defect which may appear during fabrication shall be made good with the consent of, and according to the procedure proposed by the Contractor and approved by the Owner.
- G) All gauges and templates necessary to satisfy the Owner shall be supplied by the manufacturer.
- H) The correct grade and quality of steel shall be used by the Contractor. To ascertain the quality of steel used the inspector may at his discretion get the material tested at an approved laboratory.

12.08.03 **Tower Load Tests**

- A) The Contractor shall submit one set of shop drawings alongwith the bill of materials. Further, Contractor shall submit one copy of test reports and final tracings of shop drawings and Bill of materials for Owner's reference and record.
- B) The Contractor shall ensure that the specification of materials and workmanship of all towers actually supplied conform strictly to the towers which have successfully under gone the tests. In case any deviation is detected, the Contractor shall replace such defective towers free of cost to the Owner. All expenditure incurred in erection, to and fro transportation and any other expenditure or losses incurred by the Owner on this account shall be fully borne by the Contractor. No extension in delivery time shall be allowed on this account.

12.08.04 **Tower Testing Procedure**

The testing of towers shall be as per the procedure described below:

A) **Bolt Slip Test**

In the bolt slip test, the test loads shall be gradually applied up to the 50% of design loads under normal condition and held for two (2) minutes at that loads and then released gradually.

## TECHNICAL REQUIREMENTS



	<p>The initial and final readings on the scales (for measurement of deflection) before application and after the release of Loads respectively shall be taken with the help of theodolite. The difference between these readings gives the values of the bolt slip.</p>
B)	<p><b>Normal/Broken Wire Load Tests</b></p> <p>All the loads, for a particular load-combination test shall be applied gradually upto the full design loads in the following steps and shall also be released in the similar manner:</p> <ul style="list-style-type: none"> <li>50 percent</li> <li>75 percent</li> <li>90 percent</li> <li>95 percent</li> <li>100 percent</li> </ul>
C)	<p><b>Observation Periods</b></p> <ul style="list-style-type: none"> <li>a) Under normal and broken wire load tests, the tower shall be kept under observation for sign of any failure for two minutes (excluding the time for adjustment of loads) for all intermediate steps of loading upto and including 95 per cent of full design loads.</li> <li>b) For normal, as well as broken wire tests, the tower shall be kept under observation for five (5) minutes (excluding the time for adjustment of loads) after it is loaded upto 100 percent of full design loads.</li> <li>c) While the loading operation are in progress, the tower shall be constantly watched, and if it shows any tendency of failure anywhere, the loading shall be immediately stopped, released and then entire tower shall be inspected. The reloading shall be started only after the corrective measures are taken.</li> <li>d) The structure shall be considered to be satisfactory, if it is able to support the specified full design loads for five (5) minutes, with no visible local deformation after unloading (such as bowing, buckling etc.) and no breakage of elements or constituent parts.</li> <li>e) Ovalization of holes and permanent deformation of bolts shall not be considered as failure.</li> </ul>
D)	<p><b>Recording</b></p> <p>The deflection of the tower shall be recorded at each intermediate and final stage of normal load and broken wire load tests by means of a theodolite and graduated scale. The scale shall be of about one meter long with marking upto 5 mm accuracy.</p>
E)	<p><b>Destruction Test</b></p> <ul style="list-style-type: none"> <li>a) The destruction test shall be carried out under normal condition or broken wire condition. The Owner at the time of approval of rigging chart/test data sheet shall intimate the contractor. Under which load condition the destruction test is to be carried out.</li> <li>b) The procedure for application of load for normal/broken wire test shall also be applicable for destruction test. However, the load shall be increased in steps of five (5) percent after the full design loads have been reached.</li> </ul>
12.09.00	<p><b>PACKING</b></p>

## TECHNICAL REQUIREMENTS



12.09.01 The packings shall be properly done to avoid losses/damages during transit. Each bundle or package shall be appropriately marked.

### 12.10.00 DESIGN CALCULATION AND DRAWINGS

12.10.01 The following design calculation and drawings are required to be furnished during detailed engineering.

- a) Computation of wind load
- b) Sag-tension calculation
- c) Tower loading
- d) Single line diagram of towers showing electrical clearances and steel sections.

12.10.02 The Contractor shall also furnish following to the owner:

- a) Detailed design calculation and drawing for towers and foundations.
- b) Detailed structural drawings indicating section size, length of members sizes of plate along with hole to hole distance, joint details etc.
- c) Bill of materials, indicating cutting and bending details against each member.
- d) Shop drawings showing all details relevant to fabrication.
- e) All the drawings for the tower accessories.

**TECHNICAL REQUIREMENTS**



**TABLE-T1-2  
DESIGN LOADS**

S.No	400 kV	Longitudinal Loads		Transverse Loads	
		Reliability Condition	Security Condition	Reliability Condition	Security Condition
1	2	3	4	5	6
a.	A	0.0	0.5 x MT For Conductor ) 1.0 x MT (For Earth Wire)	WC + WI + DY	0.6 WC + WI +0.25 DY (For Conductor) 0.6 WC + 0.5 DY (For Earth Wire)
b.	B (Section Tower- 0° Deviation)	0.0	1.0 x MT	WC + WI + DY	0.6 WC + WI +0.5 DY
c.	B ( 15° Deviation)	0.0	1.0 x MT x Cos Φ/2	WC + WI + DY	0.6 WC + WI +0.5 DY
d.	C (Section Tower- 0° Deviation)	0.0	1.0 x MT	WC + WI + DY	0.6 WC + WI +0.5 DY
e.	C (30° Deviation)	0.0	1.0 x MT x Cos Φ/2	WC + WI + DY	0.6 WC + WI +0.5 DY
f.	D (60° Deviation)	0.0	1.0 x MT x Cos Φ/2	WC + WI + DY	0.6 WC + WI +0.5 DY
g.	D (90° Deviation)	0.0	1.0 x MT x Cos Φ/2	WC + WI + DY	0.6 WC + WI +0.5 DY
h.	D Complete Dead End	MT	1.0 x MT	WC + WI	0.1 WC + WI

DESCRIPTION	SYMBOL	REMARKS
Maximum Tension Of Conductor/ Earth Wire under everyday temperature & full wind condition or minimum temperature & 36% Of max. wind which ever is more stringent	MT	
Wind On Conductor	WC	Wind Span shall be the normal ruling span.
Wind On Insulator	WI	In case of Double String Insulators, both their strings shall be considered
Angle Of Deviation (Degrees)	Φ	
Load Due To Deviation Of Tower	DY= 2 x MT x Sin Φ/2	

## TECHNICAL REQUIREMENTS



Note:

1. Vertical loads shall conform to IS 802 – Part I, 1995. Weight spans as furnished under Clause 2.03.00 shall be considered for computation of vertical loads.
2. Safety loads and Anti-cascade loads as specified in IS 802- Part I, 1995 shall also be considered for design of Towers.
3. Wind loads on the towers shall be considered in transverse loads as per clause 11, 12 and 13 of IS: 802 (Part-I/ Sec. I)- 1995.
4. Any additional loads apart from the loads mentioned above, as required as per IS: 802- 1995 shall be considered for design purpose.

### 13.00.00 TOWER FOUNDATIONS

#### 13.01.00 TYPES OF FOUNDATION

##### 13.01.01 General

- A) Reinforced concrete footing shall be used for all type of normal tower in conformity with the present day practice followed in the country and the specifications laid herein. All the four footings of the tower and their extension shall be similar, irrespective of down thrust and uplift.
- B) Foundation includes supply of materials such as cement, sand, coarse aggregates, reinforcement steel etc., and all work related to construction of foundations including excavation and backfilling, form work, stub setting, placing of reinforcement, concreting etc.

##### 13.01.02 Design criteria for Foundations

The foundation shall be designed for the actual soil parameters based on the soil investigation carried out by the bidder and approved by the owner. For design purposes:

- (a) The angle of repose shall be considered as two-third (2/3) of the value as obtained from the soil investigation
- (b) Water table shall be considered up to the ground level.
- (c) The weight of soil shall be considered as 1440 Kg/m<sup>3</sup> under dry condition and 940 Kg/m<sup>3</sup> under wet condition.

Well foundation or pile foundation shall be provided by the bidder wherever necessitated.

#### 13.02.00 SOIL INVESTIGATION

13.02.01 The Contractor is required to carry out detailed soil investigation at various tower locations along the corridor, one borehole at centre of the tower, angle points, crossings, etc. and also where soil strata is different from the other locations

## TECHNICAL REQUIREMENTS



13.02.02	<p>investigated. In addition the soil investigation may be required to be carried at other locations at the discretion of the Engineer.</p> <p>The investigation comprises of field and laboratory testing. Field investigation includes boreholes, Standard Penetration Test (SPT), Static Cone Penetration Test (SCPT), Dynamic Cone Penetration Test (DCPT), collection of disturbed samples (DS) and undisturbed soil samples (UDS), Trial Pits (TP), Plate Load Tests (PLT), Electrical Resistivity Test (ERT), collection of water samples, etc. Laboratory tests shall include, Physical, chemical and engineering properties of soil/rock.</p> <p>This specification covers technical requirements for geotechnical investigation and preparation of a detailed geotechnical report. It shall include mobilization of necessary equipment, providing necessary engineering supervision and technical personnel, carrying out field investigation and tests, laboratory tests, analysis and interpretation of data and results, collecting data regarding change of course of rivers from local sources, velocity, scour, etc., giving flood details of the area (past history), safe bearing capacity for different sizes of foundations, different founding strata for the various locations along the transmission lines and preparation of geotechnical report.</p>
13.02.03	<p>The diameter of borehole shall be minimum 150 mm in soil and 76 mm in rock. Depth of bore holes at river/bridge crossings shall be 40m, at angle points depth shall be 15.0m and at the centre of tower along the corridor depth of BH shall be 10.0m. Boring shall be terminated at the above specified depth or 3.0m continuous in rock with RQD&gt;25% for river crossings and for balance areas 3.0m in refusal whichever is earlier. Refusal means SPT 'N' value greater than 100.</p> <p>SPT shall be carried out in all types of soil deposits and in all rock formations with core recovery up to 20%, met within a borehole. This test shall be conducted at every 3.0 m interval or at change of strata, up to the final depth. At refusal penetration shall be measured and the same shall be reported in Borelog. UDS shall be collected at every 3.0 m interval or at change of strata up to depth of borehole. UDS may be replaced by additional SPT, if SPT'N' value in the strata is above 50. The diameter of UDS sampler shall be 100 mm minimum.</p>
13.02.04	<p>Laboratory tests shall be done as per relevant IS codes. The laboratory tests, not be limited to the following shall be conducted on disturbed and undisturbed soil samples, rock samples &amp; water samples collected during field investigations in sufficient numbers.</p> <p><b>a) Laboratory Tests on Soil Samples</b></p> <p>Laboratory tests shall be carried out on disturbed and undisturbed soil samples for Grain Size Analysis, Hydrometer Analysis, Atterberg Limits, Triaxial Shear Tests (UU), Natural Moisture Content, Specific Gravity and Bulk Unit Weight, Consolidation Tests, Unconfined Compression Test, Free swell Index, Shrinkage Limit, Swell Pressure Test, Chemical Analysis test on soil and water samples to determine the carbonates, sulphates, chlorides, nitrates, pH, organic matter and any other chemicals harmful to concrete and reinforcement/ steel.</p> <p><b>b) Laboratory Tests on Rock Samples</b></p>

**TECHNICAL REQUIREMENTS**



<p>13.02.05</p> <p>13.02.06</p> <p>13.02.07</p>	<p>Moisture content, porosity &amp; density, Specific Gravity, Hardness, Soundness, Slake durability index, Unconfined compression test (Both at saturated and in-situ water content), Point load strength index and deformability test (Both at saturated and in-situ water content) shall be carried out on rock samples.</p> <p>The laboratory tests shall be carried out progressively during the field work after sufficient numbers of samples have reached the laboratory in order that the test results of the initial boreholes can be made use of in planning the later stages of the field investigation and quantum of laboratory tests. All samples brought from field, whether disturbed or undisturbed shall be extracted/prepared and examined by competent technical personnel and the tests shall be carried out as per the procedures laid out in the latest editions of the relevant IS codes. Soil shall be classified as per the provisions of Indian standards.</p> <p>On completion of all field &amp; laboratory work, geotechnical investigation report shall be submitted for Owner’s review/approval. The Geotechnical investigation report shall contain geological information of the region, procedure adopted for investigation, field &amp; laboratory observations/ data/ records, analysis of results &amp; recommendations on type of foundation envisaged for all areas of work with supporting calculations. Recommendations on treatment for soil, foundation, based on subsoil characteristics, soft soils, aggressive chemicals, expansive soils, etc.</p> <p>The Geotechnical report shall include, but not limited to the following:</p> <p>a) Borelogs: A true cross section of all individual boreholes with reduced levels and coordinates, showing the classification and thickness of individual stratum, position of ground water table, details of various in-situ tests conducted and samples collected at different depths and the rock stratum, wherever met with.</p> <p>b) Results of all laboratory tests summarized for each Borehole along with a consolidated table giving the layer wise soil and rock properties. All the relevant charts, tables, graphs, figures, supporting calculations, conditions and photographs of representative rock cores shall be furnished.</p> <p>c) Recommendations : The report should contain specific recommendations on type of foundations to be adopted for various structures, duly considering the sub soil characteristics, water table, total/ differential settlement permissible for structures and equipments, minimum depth and width of foundation. The observation/recommendations shall include but not limited to the following:</p> <p>i) Geological information of the area, past observations or historical data, if available, for the area and for the structures in the nearby area, fluctuations of water table etc.</p> <p>ii) Net safe allowable bearing pressure on the soil at various depths for different sizes of the foundations based on shear strength and settlements characteristics of soil with supporting calculations for the recommendations.</p> <p>iii) Based on the chemical nature of soil and ground water and exposure condition, recommendations for protective measures on concrete and steel shall be mentioned.</p>
---	---

**TECHNICAL REQUIREMENTS**



<p>13.02.08</p>	<p>iv) If expansive soil is met with, recommendation and removal or retainment of the same under structures/ roads etc. shall be given. In the later case detailed specification of any special treatment required including specifications for materials to be used, construction method, equipments to be deployed, etc. shall be furnished.</p> <p>iv) Additional investigation other then specified above, if any, the same shall be carried out by the bidder at no extra cost to owner.</p> <p>Indian Standard References</p> <p>IS:1498 Classification and Identification of Soils for general Engineering Purposes.</p> <p>IS:1892 Code of practice for Subsurface Investigation for Foundation.</p> <p>IS:1904 Code of practice for design and construction of foundations in Soils: General Requirements.</p> <p>IS:2131 Method of Standard Penetration Test for Soils.</p> <p>IS:2132 Code of practice for Thin walled Tube Sampling of Soils.</p> <p>IS:2470 Code of practice for design and construction of Septic Tanks.</p> <p>(Part-I)</p> <p>IS:2720 Method of Test for Soils (Relevant Parts).</p> <p>IS:5313 Guide for Core Drilling Observations.</p> <p>IS:4968 Method for subsurface Sounding for Soils - Dynamic</p> <p>(Part-II) method using Cone and Bentonite slurry.</p> <p>IS:4968 Method for subsurface Sounding for Soils- Static Cone Penetration</p> <p>(Part-III) Test</p>
<p>13.04.00</p>	<p><b>LOADS ON FOUNDATIONS</b></p>
<p>13.04.01</p>	<p>The foundations shall be designed to withstand the specific loads of the superstructure and for the full footings reactions obtained from the structural stress analysis in conformity with the relevant over load factors. The over load factor for foundation design shall be 1.10 for all loads except dead loads.</p>
<p>13.04.02</p>	<p>The reactions on the footings shall be composed of the following type of loads for which these shall be required to be checked :</p>
<p>i) ii) iii)</p>	<p>Max. tension or uplift along the leg slope. Max. compression or down-thrust along the leg slope. Max. horizontal shear or side thrust.</p>
<p>13.04.03</p>	<p>The base slab of the foundation shall be designed for additional moments developing due to eccentricity of the loads.</p>

**TECHNICAL REQUIREMENTS**



	<p align="center"><b>TECHNICAL REQUIREMENTS</b></p> 
<p>13.04.04</p> <p>13.05.00</p> <p>13.05.01</p> <p>13.05.02</p> <p>A)</p> <p>B)</p> <p>C)</p> <p>13.06.00</p> <p>13.06.01</p> <p>13.06.02</p> <p>13.06.03</p>	<p>The additional weight of concrete in the footing below ground level over the earth weight and the full weight of concrete above the ground level in the footing and embedded steel parts will also be taken into account adding to the down thrust.</p> <p><b>STABILITY ANALYSIS</b></p> <p>In addition to the strength design, stability analysis of the foundation shall be done to check the possibility of failure by over-turning, uprooting, sliding and tilting of the foundation.</p> <p>The following primary type of soil resistance shall be assumed to act in resisting the loads imposed on the footing in earth:</p> <p>Resistance against uplift</p> <p>The uplift loads will be assumed to be resisted by the weight of earth in an inverted frustum of a conical pyramid of earth as per relevant formula on the footing pad whose sides make an angle equal to the angle of repose of the earth with the vertical, in average soil. The weight of concrete embedded in earth and that above the ground will also be considered for resisting the uplift. In case where the frustum of earth pyramids of two adjoining legs super-impose each other, the earth frustum will be assumed truncated by a vertical plane passing through the center line of the tower base.</p> <p>Resistance against down thrust</p> <p>The down-thrust load combined with the additional weight of concrete above earth will be resisted by bearing strength of the soil assumed to be acting on the total area of the bottom of the footings.</p> <p>Resistance against side-thrust</p> <p>The chimney portion of the foundation shall be designed as per limit load method described at clause 38.6 of IS-456-1978, or as per any other international standard, considering the chimney as a column subjected to axial loads (down thrust loads) and biaxial bending moments resulting from side thrust forces. The passive earth pressure (as per Rankine's formula) shall be considered for the design of chimney against side thrust. If uplift and down thrust are computed in vertical direction for the foundation design, full resultant horizontal shear shall be taken at footing tip for design of the footing to resist side thrust.</p> <p><b>PROPERTIES OF CONCRETE</b></p> <p>The cement concrete used for the foundations shall be of grade M-20 corresponding to 1:1½:3 nominal mix ratio with 20mm coarse aggregate.</p> <p>All the properties of concrete regarding its strength under compression tension, shear, punching and bend etc. as well as workmanship will conform to IS:456-1978.</p> <p>The material properties for cement, aggregate and reinforcement steel shall be as specified elsewhere in the specification</p>

**TECHNICAL REQUIREMENTS**



<p>13.06.04</p> <p>13.07.00</p> <p>134.07.01</p> <p>13.07.02</p> <p>13.07.03</p> <p>13.07.04</p> <p>13.07.05</p> <p>13.07.06</p> <p>13.07.07</p> <p>13.07.08</p> <p>13.07.09</p> <p>13.08.00</p> <p>13.08.01</p>	<p>The water used for mixing concrete shall be fresh, clean and free from oil, acids and alkalis, organic materials or other deleterious substances. Portable water is generally preferred.</p> <p><b>DESIGN OF FOUNDATIONS</b></p> <p>Structural design of the foundations shall be done by limit State method conforming to IS 456.</p> <p>The chimney should have all around clearance of 150mm from any part of stub angle limiting to 450mm sq. minimum.</p> <p>The chimney top or muffing must be at least 225 mm above ground level and also the coping shall be extended upto lower most joint level between the bottom lattices and the main corner legs of the tower.</p> <p>Minimum thickness of foundation shall be 300 mm.</p> <p>The minimum distance between the lowest edge of the stub angle and the bottom surface of concrete footing shall not be less than 150 mm or more than 200mm.</p> <p>The total depth of foundations below the ground level shall not be less than 1.5 meters. To maintain the interchangeability of stubs for all types of foundations, for each type of tower, the same depths of foundations shall be used for different types of foundations.</p> <p>The portion of the stub in the pyramid (or slab) shall be designed to take full down-thrust or uplift loads by the cleats combined with the bond between stub angles and pyramid concrete. The Contractor shall furnish the calculation for uprooting of stub along with the foundation design.</p> <p>Minimum 50mm thick pad of lean concrete corresponding to 1:3:6 nominal mix shall be provided to avoid the possibility of reinforcement rod being exposed due to unevenness of the bottom of the excavated pit.</p> <p>Over Load Factor</p> <p>The overload factor for foundations shall be considered as 1.1 i.e. the reaction except due to dead loads on foundations shall be increased by 10 per cent.</p> <p><b>CONSTRUCTION OF TOWER FOUNDATION</b></p> <p><b>Excavation</b></p> <p>Excavation work must not be started until the tower schedule &amp; profile and foundation drawing are approved by the Owner.</p> <p>Except specified otherwise, all excavation for footing shall be made to the lines and grades of the foundation. All excavation shall be protected so as to maintain a clean subgrade, until the footing is placed, using timbering/shuttering, shoring etc., if necessary. Any sand, mud, silt or other undesirable materials which may accumulate in the excavated pit shall be removed by the Contractor before placing concrete.</p>
--	--

## TECHNICAL REQUIREMENTS



### 13.08.02 Rock excavation requiring Blasting

Wherever blasting is required for excavation in rock, the same shall be done after obtaining license from the competent authority. Following shall be adhered to:

- i) All provisions of explosive acts shall be adhered to.
- ii) The magazine for the storage of explosive shall be to suit as per the requirements of explosive department.
- iii) Where blasting is required, same shall be controlled blasting.
- iv) Contractor shall prepare the detailed blasting scheme and get the same approved from Engineer-in-charge before carrying out the blasting operation. All blasting shall be done as per the approved blasting scheme.
- v) The Contractor shall obtain Licenses from Competent Authorities for undertaking blasting work as well as for procuring, transporting to site and storing the explosives as per explosives act. The Contractor shall be responsible for the safe transport, use, custody and proper accounting of the explosive Materials.
- vi) The Contractor shall also observe any specific instructions given by the Engineer-in-charge. The Contractor shall be responsible and liable for any accident and injury / damage which may occur to any person or property of the project or public on account of any operations connected with the storage, transportation, handling or use of explosives and the blasting operations. The Engineer-in-charge or his authorised representative shall frequently check the Contractor's compliance with these precautions and the manner of storing and accounting of explosives. The Contractor shall provide necessary facilities for this the above.
- vii) Controlled blasting shall be done by a specialised agency duly approved by Engineer-in-charge. All controlled blasting shall be done by using time delay detonators (i.e. excel type).
- viii) All rules under the Explosives Act and other local rules in force shall be fully observed. All blasting works shall be done in accordance with the stipulations contained in IS: 4081.

### 13.08.03 Setting of Stubs

A) The stubs shall be set correctly in accordance with approved method at the exact location and alignment and precisely at correct levels with the help of stub setting templates and leveling instrument. Stubs shall be set in the presence of Owner's representative available at site where required and for which adequate advance intimation shall be given to the Owner by the Contractor.

B) Setting of stub at each location shall be approved by the Owner's representative.

C) Stub setting templates shall be designed and arranged by the Contractor at his own cost for all types of towers with or without extension and also for leg extension. Stub templates for standard towers and towers with extension upto 6M shall be of adjustable type. The stub templates shall be painted. Generally for each

## TECHNICAL REQUIREMENTS



transmission line tower package, following numbers of stub setting templates shall be deployed by the Contractor:

For each A type tower : 3 Nos.  
For each of B and C type : 2 Nos.

However, if Owner feels that more number of templates are required for timely completion of a particular line the Contractor shall have to deploy the same without any extra cost to Owner.

D) One set of each type of stub setting template as applicable, shall be supplied to the Owner, on completion of the project at no extra cost to Owner.

### 13.08.04 Mixing, Placing and Compacting of Concrete

- A) The concrete shall be mixed in a mechanical mixer. However, in case of difficult terrain hand mixing may be permitted at the discretion of Owner. The water for mixing concrete shall be fresh, clean and free from oil, acids and alkalies. Saltish or blackish water shall not be used.
- B) Mixing shall be continued until there is uniform distribution of material and the mix is uniform in colour and consistency, but in no case the mixing be done for less than two minutes. Normally mixing shall be done close to the foundation, but in case it is not possible the concrete may be mixed at the nearest convenient place. The concrete shall be transported from the place of mixing to the place of final deposit as rapidly as practicable by methods which shall prevent the segregation or loss of any ingredient. The concrete shall be placed and compacted before setting commences.
- C) Form boxes shall be used for casting all type of foundations. The concrete shall be laid down in 150mm layers and consolidated well, so that the cement cream works up to the top and no honey-combing is left in the concrete. The mechanical vibrator shall be employed for compaction of the concrete. However, in case of difficult terrain, manual compaction may be permitted at the discretion of Owner. After concreting the chimney portion to the required height, the top surface should be finished smooth with a slight slope towards the outer edge, to drain off any rain water falling on the coping.
- D) In wet locations, the site must be kept complete de-watered, both during the placing of the concrete and for 24 hours thereafter. There should be no disturbance of concrete by water during this period.
- E) After the form-work has been removed if the concrete surface is found to be defective, the damage shall be repaired with rich cement and sand mortar to the satisfaction of the Owner's representative before the foundation pits are backfilled.

### 13.08.05 Back-Filling and Removal of Stub Template

- A) After opening of form-work and removal of shoring and timbering, if any, backfilling shall be started, after repairs, if any, to the foundation concrete. Backfilling shall normally be done with excavated soil, unless it consists of large boulders/stones, in which case the boulders shall be broken to a maximum size of 80 mm. At such locations where borrowed earth is required for backfilling, shall be done by the Contractor at his own cost, irrespective of lead.

**TECHNICAL REQUIREMENTS**



<p>B)</p> <p>C)</p> <p>13.08.06</p> <p>13.08.07</p> <p>13.08.08</p>	<p>The backfilling materials should be clean and free from organic or other foreign materials. The earth shall be deposited in maximum 200 mm layers, leveled and wetted and tempered properly before another layer is deposited. Care shall be taken that the backfilling is started from the foundation ends of the pits, towards the outer ends. After the pits have been backfilled to full depth, the stub template may be removed.</p> <p>The backfilling and grading shall be carried to an elevation of about 75 mm above the finished ground level to drain out water. After backfilling 50 mm high earthen embankment (bandh) will be made along the sides of excavation pits and sufficient water will be poured in the backfilled earth for atleast 24 hours.</p> <p><b>Curing</b></p> <p>The concrete after setting for 24 hours shall be cured by keeping the concrete wet continuously for a period of 10 days after laying. The pit may be back filled with selected earth sprinkled with necessary amount of water and well consolidated in layers not exceeding 200 mm of consolidated thickness after a minimum period of 24 hours and thereafter both the backfilled earth and exposed chimney top shall be kept wet for the remainder of the prescribed time of 10 days. The uncovered concrete chimney above the backfilled earth shall be kept wet by providing empty cement bags dipped in water fully wrapped around the concrete chimney for curing and ensuring that the bags are kept wet by the frequent pouring of water on them.</p> <p><b>Benching</b></p> <p>When the line passes through hilly/undulated terrain, for a few tower locations it may be required to level the ground for casting of tower footings on same elevation. All the activities related to make the required area of ground in same elevation for casting of foundation, shall be termed as benching work. Benching work shall include cutting of excess earth and removing the same to a suitable point of disposal as required by the Owner. Benching shall be resorted to only after getting specific approval from the Owner. Volume of the earth to be cut shall be measured before cutting and got approved from the Owner. This volume of earth shall be considered for the purpose of payment against the head of benching work. The earth removed for setting of stub template or for casting of foundation with difference of elevations of 1M between the tower legs shall not be entitled for payment.</p> <p><b>Protection of Tower Footing</b></p> <p>A) The work shall include all necessary stone revetments, concreting and earth filling above ground level and the clearance from stacking on the site of all surplus excavated soil, special measures for protection of foundation close to or in nallahas, river bed hilly/undulated terrain etc, by providing suitable revetments or galvanised wire netting and meshing packed with boulders. The top seal cover of the stone revetments shall be done with M-15 concrete (1:2:4:mix). The Contractor shall furnish recommendations for providing protection at these locations wherever required.</p> <p>B) The quantity of excavated earth obtained from a particular location shall generally be utilised in back-filling work in protection of tower footing of same locations, unless it is unsuitable for such purpose. In the latter case, the back-filling shall be done with</p>
---	---

**TECHNICAL REQUIREMENTS**

borrowed earth of suitable quality irrespectively of lead as per the rate provided in the letter of award. The consolidation of earth shall however be done after backfilling free of cost.

**14.00.00 TOWER LINE ERECTION AND STRINGING****14.01.00 GENERAL REQUIREMENTS**

14.01.01 The details of the scope of erection work shall include the cost of labour, all tools and plants like tension stringing equipment and all other incidental expenses in connection with erection and stringing work.

14.01.02 The Contractor shall be responsible for transportation of all the materials to be provided by the Contractor as per the scope of work to site, proper storage and preservation at their own cost till such time the erected line is taken over by the Owner.

**14.02.00 TREATMENT OF MINOR GALVANISING DAMAGE**

In case any minor damage to galvanising is noticed, the same shall be treated with zinc rich paint (having at least 90% zinc content) before erection.

**14.03.00 ASSEMBLY**

14.03.01 The method followed for the erection of towers, shall ensure the points mentioned below :

- a) Straining of the members shall not be permitted for bringing them into position. It may, however, be necessary to match hole positions at joints and to facilitate this, tommy bars not more than 450 mm long may be used.
- b) Before starting erection of an upper section, the lower section shall be completely braced and all bolts provided and tightened adequately in accordance with approved drawings to prevent any mishap during tower erection.
- c) All plan diagonals relevant to a section of tower shall be placed in position before assembly of upper section is taken up.
- d) The bolt position in assembled towers shall be as per IS:5613 (Part-II/Section 2)-1976.
- e) Tower shall be fitted with number plate, danger plate, phase plate and anti-climbing device as described.
- f) All bank holes, if any left, after complete erection of the tower, are to be filled up by bolts and nuts of correct size.

14.03.02 Tightening and Punching of Bolts and Nuts

- A) All nuts shall be tightened properly using correct size spanner/torque wrench. Before tightening, it shall be ensured that filler washers and plates are placed in gaps

## TECHNICAL REQUIREMENTS



between members wherever applicable, bolts of proper size and length are inserted, and one spring washer is inserted under each nut. In case of step bolts, spring washers shall be placed under the outer nut. The tightening shall progressively be carried out from the top downwards, care being taken that all bolts at every level are tightened simultaneously. The threads of bolts projecting outside the nuts shall be punched at their position on the diameter to ensure that the nuts are not loosened in course of time. If during tightening a nut is found to be slipping or running over the bolt threads, the bolt together with the nut shall be replaced.

- B) The threads of all the bolts projected outside the nuts shall be welded at two diametrically opposite places. The welding shall be provided from ground level to waist level for single circuit towers and to bottom cross arm level for double circuit towers. After welding, cold galvanised paint having at least 90% Zinc content shall be applied to the welded portion. At least two coats of the paint shall be applied. The cost of welding and paint including application of paint shall be deemed to be included in the erection price.
- C) In addition to the tack welding of nuts with bolts, as described above, the Contractor can also propose some alternative arrangements, like use of epoxy resin adhesive which can serve the purpose of locking the nut permanently with the bolt and thus preventing pilferage of the tower members.

**14.04.00 INSULATOR HOISTING**

Suspension insulator strings shall be used on suspension towers and tension insulator strings on angle and dead end towers. These shall be fixed on all the towers just prior to the stringing. Damaged insulators and fittings, if any, shall not be employed in the assemblies. Before hoisting, all insulators shall be cleaned in a manner that will not spoil, injure or scratch the surface of the insulator, but in no case shall any oil be used for the purpose. Corona control rings/arching horn shall be fitted in an approved manner. The yoke arrangements be horizontal for tensions strings. Torque wrench shall be used for fixing different line materials and their components, like suspension clamp for conductor and earthwire, etc., whenever recommended by the manufacturer of the same of river crossing towers.

**14.05.00 HANDLING OF CONDUCTOR AND EARTHWIRE**

**14.05.01** The Contractor shall be entirely responsible for any damage to the towers or conductors during stringing. While running out the conductors, care shall be taken that the conductors do not touch or rub against the ground or objects which could cause scratches or damages to the strands. The conductors shall be run out of the drums from the top in order to avoid damage due to chafing. Immediately after running out, the conductor shall be raised at the supports to the levels of the clamps and placed into the running blocks. The groove of the running blocks shall be of such a design that the seat is semi-circular and larger than the diameter of the conductor earthwire and it does not slip over or rub against the sides. The grooves shall be lined with hard rubber or neoprene to avoid damage to conductor and shall be mounted on properly lubricated bearings.

**14.05.02** The running blocks shall be suspended in a manner to suit the design of the crossarm. All running blocks, especially those at the tension end, will be fitted on the cross-arm with jute cloth wrapped over the steel work and under the slings to avoid

## TECHNICAL REQUIREMENTS



damage to the slings as well as to the protective surface finish of the steel work. In case suspension, or section towers are used even for temporary terminations, if this be unavoidable, they shall be well guyed and steps shall be taken by the Contractor to avoid damage. Guying proposal alongwith necessary calculations shall be submitted by the Contractor to Owner by the Contractor for checking the tensions in the guy made available to the Owner by the Contractor for checking the tensions in the guy wires. The drums shall be provided with a suitable braking device to avoid damages, loose running out and kinking of the conductor. The conductor shall be continuously observed for loose or broken strands or any other damage. When approaching end of a drum length, at least three coils shall be left when the stringing operations are to be stopped. These coils are to be removed carefully, and if another length is required to be run out, a joint shall be made as per the recommendations of the manufacturers.

- 14.05.03 Repairs to conductors, if necessary, shall be carried out during the running out operations, with repair sleeves. Repairing of conductor surface shall be done only in case of minor damage, scuff marks etc. keeping in view both electrical and mechanical safe requirements. The final conductor surface shall be clean smooth and without any projections, sharp points, cuts, abrasions etc.
- 14.05.04 Conductor splices shall be so made that they do not crack or get damaged in the stringing operation. The contractor shall use only such equipment/methods during conductor stringing which ensures complete compliance in this regard.
- 14.05.05 Derricks shall be used where roads, rivers, channels, telecommunication or overhead power lines, railway lines, fences or walls have to be crossed during stringing operations. It shall be seen that normal services are not interrupted or damage caused to property. Shut down shall be obtained when working at crossing of overhead power lines. The Contractor shall be entirely responsible for the proper handling of the conductor, earth-wire and accessories in the field.
- 14.05.06 The sequence of running out shall be from top to downwards i.e. the earthwire shall be run out first, followed by the conductors in succession. Unbalances of loads on towers shall be avoided as far as possible.
- 14.05.07 The proposed 66 kV transmission line may run parallel for certain distance with the existing Transmission lines which may remain energised during the stringing period. As a result there is a possibility of dangerous voltage build up due to electromagnetic and electrostatic coupling in the pulling wire, conductors and earthwires, which although comparatively small during normal operations can be severe during switching. It shall be the Contractor's responsibility to take adequate safety precautions to protect his employees and others from this potential danger.
- 14.05.08 B and C type of towers are not designed for one side stringing. Therefore proper guying arrangement shall be made for B and C type of towers during stringing on one section while the other section is not strung. The Contractor has to submit the detailed proposal along with the calculation for guying which shall be approved by the Owner. Proper T&P shall be made available to the Owner by the Contractor for checking the tensions in the guy wires. All the expenditure on account of the above work is deemed to be included in the bid price and no extra payment shall be made for the same.

**TECHNICAL REQUIREMENTS**



<p>14.06.00</p> <p>14.06.01</p> <p>14.06.02</p> <p>14.06.03</p> <p>14.06.04</p> <p>14.06.05</p> <p>A)</p> <p>B)</p> <p>C)</p> <p>14.07.00</p> <p>14.07.01</p> <p>14.07.02</p> <p>14.07.03</p>	<p><b>STRINGING OF CONDUCTOR AND EARTHWIRE</b></p> <p>The stringing of the conductor shall be done by standard stringing method.</p> <p>After being pulled the conductor/earthwire shall not be allowed to hang in the stringing blocks for more than 96 hours before being pulled to the specified sag.</p> <p>Conductor creep are to be compensated by over tensioning the conductor at appropriate temperature for which calculations are to be submitted by the contractor for Owner's approval.</p> <p>The Bidder shall give complete details of the stringing methods which be proposes to follow. Before the commencement of stringing the Contractor shall submit the stringing charts for the conductor and earthwire for various temperatures and span alongwith equivalent spans for the approval of the Owner.</p> <p>Jointing</p> <p>All the joints on the conductor and earthwire shall be of compression type, in accordance with the recommendations of the manufacturer for which all necessary tools and equipment like compressors, dies, processes etc. shall have to be arranged by the Contractor. Each part of the joint shall be cleaned by wire brush to make it free of rust or dirt etc. and properly greased with anti- corrosive compound if required, and as recommended by the contractor before the final compression is done with the compressors.</p> <p>All joints or splices shall be made at least 30 meters away from the structures. No joints or splices shall be made in spans crossing over main road, railways, small rivers with tension spans. During compression or splicing operation the conductor shall be handled in such a manner as to prevent lateral or vertical bearing against the dies. After pressing the joint the aluminium sleeve shall have all corners rounded, burrs and sharp edges removed and smoothed.</p> <p>During stringing of conductor to avoid any damage to the joint, the Contractor shall use a suitable protector with mid span compression joints in case joints are to be passed over pulley blocks/aerial rollers. The size of the groove of the pulley shall be such that the joint along with protection can be passed over it smoothly.</p> <p>Sagging-in-Operation</p> <p>The conductor shall be pulled upto the desired sag and left in running blocks for atleast one hour after which the sag shall be re-checked and adjusted, if necessary before transferring the conductor from the running blocks to the suspension clamps. The conductors shall be clamped within 36 hours of sagging in.</p> <p>The sag will be checked in the first and the last span of the section in case of sections upto eight spans and in one intermediate span also for sections with more than eight spans. The sag shall also be checked when the conductors have been drawn up and transferred from running blocks to the insulator clamps.</p> <p>The running blocks, when suspended from the transmission structure for sagging shall be so adjusted that the conductors on running blocks will be at the same height as the suspension clamp to which it is to be secured,</p>
---	--

**TECHNICAL REQUIREMENTS**



<p>14.07.04</p> <p>14.07.05</p> <p>14.07.06</p> <p>14.07.07</p> <p>14.07.08</p> <p>14.08.00</p> <p>14.08.01</p> <p>14.08.02</p>	<p>At sharp vertical angles, the sags and tensions shall be checked on both sides of the angle, the conductor and earthwire shall be checked on the running blocks for equality of tension on both sides. The suspension insulator assemblies will normally assume vertical positions when the conductor is clamped.</p> <p>Tensioning and sagging operations shall be carried out in clam weather when rapid changes in temperatures are not likely to occur.</p> <p><b>Tensioning and Sagging of Conductors and Earthwire</b></p> <p>The tensioning and sagging shall be done in accordance with the approved stringing charts before the conductors and earthwire are finally attached to the tower through the earthwire clamps for the earthwire and insulator strings for the conductor. The 'Initial' stringing chart shall be used for the conductor and 'final' stringing chart for earth-wire should be employed for this purpose. Dynamometers shall be employed for measuring tension in the conductor and earthwire. The dynamometers employed shall be periodically checked and calibrated with the standard dynamometer.</p> <p><b>Clipping In</b></p> <p>A) Clipping of the conductors in positions shall be done in accordance with the recommendations of the manufacturer. Conductor shall be fitted with armour rods where it is made to pass through suspension clamps.</p> <p>B) The jumpers at the section and angle towers shall be formed to parabolic shape to ensure maximum clearance requirements and shall match the jumper drops shown in the tower drawings.</p> <p>C) Fasteners in all fittings and accessories shall be secured in position. The security clip shall be properly opened and sprung into position.</p> <p><b>Fixing of Conductor and Earthwire Accessories</b></p> <p>Vibration dampers for conductor and earthwire and other conductor and earthwire accessories shall be installed by the Contractor as per the design requirement and respective manufacturer's instructions within 24 hours of the conductor/earthwire clamping. While installing the conductor and earthwire accessories, proper care shall be taken to ensure that the surfaces are clean and smooth and no damage shall occur to any part of the accessories.</p> <p><b>REPLACEMENT</b></p> <p>If any replacements are to be effected after stringing and tensioning or during maintenance, leg members and bracings shall not be removed without reducing the tension on the tower with proper guying or releasing the conductor. If the replacement of cross arms becomes necessary after stringing, the conductor shall be suitably tied to the tower at tension points or transferred to suitable roller pulleys as suspension points.</p> <p>The Contractor shall not be required to return to the Owner, empty conductor and earthwire drums and shall dispose off the same at his cost except for steel drums which shall be returned to Owner.</p>
---	--

**TECHNICAL REQUIREMENTS****14.09.00 FINAL CHECKING TESTING AND COMMISSIONING**

14.09.01 After completion of the works, final checking of the line shall be done by the Contractor to ensure that all the foundation works, tower erection, and stringing have been done strictly according to the specifications and as approved by the Owner. All the works shall be thoroughly inspected keeping in view of the following main points:

- a) Sufficient backfilled earth is lying over each foundation pit and it is adequately compacted.
- b) Concrete chimneys and their copings are in good finally shaped conditions.
- c) All the tower members are correctly used, strictly according to final approved drawing and are free of any defect or damage, whatsoever.
- d) All bolts are properly tightened and punched/tack welded.
- e) The stringing of the conductors and earthwire has been done as per the approved sag and tension charts and desired clearances are clearly available.
- f) All conductor and earthwire accessories are properly installed.
- g) All other requirements to complete the work like fixing of danger plate, phase plate, number plate, anti climbing device etc., are properly installed.
- h) Wherever required it should be ensured that revetment is provided.
- i) The original tracings of profile route alignment and tower, design, structural drawings, bill of material, shop drawings of all towers are submitted to the Owner for reference and record.
- j) The insulation of line as a whole is tested by the Contractor by providing his own equipment, labour etc. to the satisfaction of the Owner.
- k) All towers are properly grounded.
- l) The line is tested satisfactorily for commissioning purpose.

**15.00.00 TRANSMISSION LINE MATERIAL****15.01.00 GENERAL**

15.01.01 All the equipment shall be of the latest design and conform to the best modern practice adopted in the extra high voltage field. The Bidder shall offer only such equipment as guaranteed by him to be satisfactory and suitable for 400 kV AC Double circuit transmission with quad moose conductor and will give continued good performance.

15.01.02 The design, manufacturing process and quality control of all the materials shall be such as to give maximum factor of safety, maximum possible working load, highest mobility, elimination of sharp edges and a good finish.

## TECHNICAL REQUIREMENTS



	<h2 style="margin: 0;">TECHNICAL REQUIREMENTS</h2>																
15.01.03	All ferrous parts shall be hot dip galvanised, after all machining has been completed, nuts may, however, be tapped (threaded) after galvanising and the threads oiled. Spring washers shall be electrogalvanised. The bolt threads shall be under cut to take care of increase in diameter due to galvanising . Galvanising shall be done in accordance with IS:2629-1972. Fasteners shall withstand four dips while spring washers shall withstand three dips. Other galvanised materials shall be guaranteed to withstand at least six dips each lasting one minute under the standard preece tests for galvanising.																
15.01.04	The zinc coating shall be perfectly adherent, of uniform thickness, smooth, reasonably bright, continues and free from imperfection such as flux, ash, rust stains, bulky white deposits and blisters. The zinc used for galvanising shall be of grade Zn. 99.95 as per IS:209-1966.																
15.02.00	<b>EARTHWIRE</b>																
15.02.01	The galvanised steel earthwire shall generally conform to the specification of ACSR core wire as mentioned in IS 398 (Part-II)-1976 except where otherwise specified herein.																
15.02.02	Parameters of the earthwire <table style="width: 100%; border: none;"> <tr> <td style="width: 60%;">(a) Size (strands &amp; wire diameter)</td> <td>7/3.15 mm</td> </tr> <tr> <td>(b) Overall diameter</td> <td>9.45 mm</td> </tr> <tr> <td>(c) Stranded weight</td> <td>428 Kg/km</td> </tr> <tr> <td>(d) Minimum ultimate tensile strength</td> <td>56 kN</td> </tr> </table>	(a) Size (strands & wire diameter)	7/3.15 mm	(b) Overall diameter	9.45 mm	(c) Stranded weight	428 Kg/km	(d) Minimum ultimate tensile strength	56 kN								
(a) Size (strands & wire diameter)	7/3.15 mm																
(b) Overall diameter	9.45 mm																
(c) Stranded weight	428 Kg/km																
(d) Minimum ultimate tensile strength	56 kN																
15.02.03	The earthwire shall be pre-formed and post-formed to avoid opening of strands at the time of cutting or joining. The finished material shall have minimum brittleness, as it will be subject to appreciable vibration while in use. It shall withstand 3 and ½ number of one minute dips in the standard preece test.																
15.02.04	There shall be no joint of any kind in the finished steel wire strand entering into the manufacture of the earthwire. There shall be no strand joints or strand splicer in any length of the completed stranded earthwire.																
15.03.00	<b>CONDUCTOR</b>																
15.03.01	The conductor shall be Aluminium Core Steel Reinforced (ACSR) type. The conductor shall confirm to IS:398 (Part-II) except where otherwise specified herein.																
15.03.02	Parameters of the conductor <table style="width: 100%; border: none;"> <tr> <td style="width: 40%;">a) Code and standard</td> <td>IS 398</td> </tr> <tr> <td>b) Name</td> <td>MOOSE ACSR</td> </tr> <tr> <td>c) Overall diameter</td> <td>31.77 mm</td> </tr> <tr> <td>d) Weight</td> <td>2.004 kg/m</td> </tr> <tr> <td>e) Ultimate tensile strength</td> <td>161.2 kN minimum</td> </tr> <tr> <td>f) Strands and wire diameter of</td> <td></td> </tr> <tr> <td style="padding-left: 20px;">- Aluminium</td> <td>54 / 3.53 mm</td> </tr> <tr> <td style="padding-left: 20px;">- Steel</td> <td>7 / 3.53 mm</td> </tr> </table>	a) Code and standard	IS 398	b) Name	MOOSE ACSR	c) Overall diameter	31.77 mm	d) Weight	2.004 kg/m	e) Ultimate tensile strength	161.2 kN minimum	f) Strands and wire diameter of		- Aluminium	54 / 3.53 mm	- Steel	7 / 3.53 mm
a) Code and standard	IS 398																
b) Name	MOOSE ACSR																
c) Overall diameter	31.77 mm																
d) Weight	2.004 kg/m																
e) Ultimate tensile strength	161.2 kN minimum																
f) Strands and wire diameter of																	
- Aluminium	54 / 3.53 mm																
- Steel	7 / 3.53 mm																
15.03.03	The steel strands shall generally comply with the requirements stipulated for earthwire at clause 16.02.00 above.																

**TECHNICAL REQUIREMENTS**



	<p align="center"><b>TECHNICAL REQUIREMENTS</b></p> 
15.03.04	<p>Joints shall be permitted in the individual Aluminium wires in all layers except the outer most layer of the finished conductor. These joints shall be made by cold pressure butt-welding and shall be such that no two such joints are within 15 metres of each other in the complete stranded conductor.</p>
15.03.05	<p>The standard length of the conductor shall be 1600 meters for conductor and 2x2000 metres for earth wire. A tolerance of <math>\pm 5\%</math> on the standard length offered by the bidder shall be permitted. All lengths outside this limit of tolerance shall be treated as random lengths. Random lengths will be accepted provided no length is less than 70% of the standard length and the total quantity of random lengths shall not be more than 10% of the total quantity ordered.</p>
15.04.00	<p><b>CONDUCTOR ACCESSORIES</b></p>
15.04.01	<p><b>Mid Span Compression Joint for Conductor</b></p>
	<p>As per details given in IS:2121 Part-2..</p>
15.04.02	<p><b>Repair Sleeve</b></p>
	<p>Repair Sleeve of compression type shall be used to repair conductor with not more than two strands broken in the outer layer. The sleeve shall be manufactured from 99.5% pure aluminium and shall have a smooth surface. The repair sleeve shall comprise of two pieces with a provision of seat for sliding of the keeper piece. The edges of the seat as well as the keeper piece shall be of rounded that the conductor strands are not damaged during installation.</p>
15.04.03	<p>The Bidder shall clearly specify the before and after compression dimensions of the mid span compression joint and repair sleeve for owner's review. The compression pressure shall also be indicated by the Bidder.</p>
15.04.04	<p><b>Vibration Damper for conductor and Earthwire</b></p>
A)	<p>Vibration dampers of 4 R-Stock bridge type with four (4) different resonance spread within the specified aeolian frequency bandwidth shall be used at all suspension and tension points on each span to damp out the Aeolean vibrations of the conductors to the specified level as mentioned hereinafter. Two dampers minimum on each side per conductor/earthwire shall be used at tension points and one damper minimum on each side per conductor at suspension points for ruling design span.</p>
B)	<p>The clamp of the vibration damper shall be made of high strength aluminium alloy of type LM-6 or equivalent.</p>
C)	<p>The messenger cable shall be made of high strength galvanised steel/stainless steel with a minimum strength of 135 kg/mm<sup>2</sup>. It shall be of pre-formed and post-formed quality in order to prevent subsequent droop of weight and to maintain consistent flexural stiffness of the cable in service. The number of strands in messenger cable shall be 19. The messenger cable other than stainless steel shall be hot dip galvanised in accordance with the recommendations of IS:4826-1979 for heavily coated wires.</p>
D)	<p>The manufacturer must indicate the clamp bolt tightening torque to ensure that the slip strength of the clamp is maintained between 2.5 KN and 5KN. The clamp when</p>

**TECHNICAL REQUIREMENTS**



installed on the conductor shall not cause excessive stress concentration on the conductor leading to permanent deformation of the conductor strands and premature fatigue failure in operation.

- E) The vibration damper for conductor shall not have magnetic power loss more than 0.5 watt at 350 amps at 50 Hz alternating current.
- F) The vibration analysis of the system, with and without damper and dynamic characteristics of the damper shall have to be submitted by the Bidder .
- G) The damper placement chart shall be submitted by the Bidder. All the placement charts should be duly supported by relevant technical documents and sample calculations.
- H) The damper placement charts shall include the following:
  - i) Location of the dampers for various combinations of spans and line tensions clearly indicating the number of dampers to be installed per conductor/earthwire per span.
  - ii) Placement distances clearly identifying the extremities between which the distances are to be measured.
  - iii) Placement recommendation depending upon type of suspension clamp (viz Free centre type, Armour grip type, etc.)
  - iv) The influence of mid span compression joints, repair sleeves and armour rods (standard and AGS) in the placement of dampers.

**15.05.00 EARTHWIRE ACCESSORIES**

**15.05.01 Mid Span Compression Joint for Earthwire**

It shall be used for joining two lengths of earthwire. The joint shall be made of mild steel. The steel sleeve should not crack or fail during compression in it or service period. The Brinnel Hardness of steel should not exceed 200. The steel sleeve shall be hot dip galvanised. The joints shall not permit slipping off, damage to , or failure of the complete earthwire or any part thereof at a load not less than 95% of the ultimate tensile strength of the earthwire. The joint shall have resistivity less than 75% of resistivity of equivalent length of earthwire. The details of the joint shall be submitted for owners approval.

**15.05.02 Vibration Damper For Earthwire**

Refer Clause 16.04.04 detailed above.

**15.05.03 Flexible Copper Bond:** As detailed in is:2121 part3.

**15.05.04 Suspension Clamp for Earthwire :** As Detailed in IS:2121 Part3

**15.05.05 Tension Clamp for Earthwire**

The details shall be as per IS:2121 part-3. Only Compression type tension clamp shall be used to hold galvanised steel earthwire. Anchor shackle shall be supplied which shall be suitable for attaching the tension clamp to strain plates. The strain plates supplied with the towers will have a minimum thickness of 8 mm with a hole

**TECHNICAL REQUIREMENTS**



of 17.5 mm diameter. Suitable lugs for jumper connection shall also be supplied alongwith necessary bolts and nuts.

**15.06.00 HARDWARE FITTINGS**

15.06.01 The hardware fittings shall be as per the specification and IS/IES standards

15.06.02 Each hardware fittings shall be supplied complete in all respects and include the following hardware parts:

- a) Ball hook for suspension hardware fittings suitable for attaching to V-hanger of the tower. Anchor shackle shall be supplied, which shall be suitable for attaching the tension hardware fittings to strain plate, of the tower.
- b) Suitable yoke plates
- c) Suspension and dead end assembly to suit conductor size.
- d) Other necessary fittings such as eye links, ball clevis, socket clevis, clevis eye, U-clevis, ball link, arcing horn etc. to make the hardware fittings complete.
- e) 2.5% extra fasteners shall be supplied along with the hardware fittings.
- f) Socket fittings shall be provided with only R-shaped security clip in accordance with IS-2486 (part-II).

**15.07.00 ANTI FOG DISC INSULATOR**

15.07.01 The size of disc insulator, the number to be used in different type of strings, their electromechanical strength and minimum creepage distance shall be as follows :

Type of String	Size of disc insulator (mm)	Min. creepage distance of each disc (mm)	No. of standard discs	Electro-mechanical strength of insulator string (kN)
Single Suspension	255/280 x 145	430	1x 23	120
Double Suspension	-do-	-do-	2x 24	2 x 120
Double tension	-do-	-do-	2x 24	2 x 120
Single tension	-do-	-do-	1x 24	120

Note: Single Suspension (Pilot) string will be used for jumpers of tension type towers. It will be similar to single suspension type except the clamp of the conductor.

- A) Disc Insulator: The insulator shall be pin and cap ; ball and socket type. The disc insulator shall conform to IS:731.
- B) Ball and Socket Designation

## TECHNICAL REQUIREMENTS



The dimensions of the balls and sockets shall be of 20 mm designation, for 90KN/120KN disc insulator in accordance with the standard dimensions stated in IS:2486-(Part-II)/IEC:120.

As alternate contractor may also offer long rod composite insulator for the above application.

### 15.07.02 **Materials**

- A) Porcelain : The porcelain used in the manufacture of shells shall be sound, free from defects thoroughly vitrified and smoothly glazed.
- B) Glaze: The finished porcelain shall be glazed in brown colour. The glaze shall cover all exposed parts of the insulator and shall have a good lustre, smooth, surface and good performance under the extreme weather conditions of a tropical climate. It shall not be cracked or chipped by ageing under the normal service conditions. The glaze shall have the same co-efficient of expansion as of the porcelain body throughout the working temperature range.
- C) Toughened Glass: In case of glass insulator, the glass used for the shells shall be sound, free from defects such as flows, bubbles, inclusions etc. and be of uniform toughness over its entire surface. All exposed glass surfaces shall be smooth.
- D) Cement: Cement used in the manufacture of the insulator shall not cause fracture by expansion or loosening by contraction. The cement shall not give rise to chemical reaction with metal fittings and its thickness shall be as small and uniform as possible. Proper care shall be taken to correctly centre and locate individual parts during cementing.
- E) Pins and Caps: Pins and Caps shall be made of drop forged steel and malleable cast iron/spheroidal graphite iron/drop forged steel respectively, duly hot dip galvanised and shall not be made by jointing, welding, shrink fitting or any other process from more than one piece of material.
- F) Security Clips: Security clips shall be made of good quality stainless steel or phosphor bronze as per IS:1385-1968 2.5% extra Security clip shall be provided.

### 15.07.03 **OPTICAL GROUND WIRE AND ACCESSORIES**

#### **General**

This specification covers the provision of one peak of 400kV tower with Optical Fiber (OPGW). This optical fiber cable will be connected to suitable optical line terminal and multiplex equipment to form part of the Plant's overall communications transmission system. Any expected variation shall be clearly identified in the Bidder's Proposal. Bidder to ensure that optical fiber characteristic of the OPGW cable to be supplied shall be compatible with the existing OPGW cable if any.

#### **Physical Characteristic**

Dual-Window Single mode (DWSM), G.652D optical fibres (minimum 24 fibres) shall be provided in the fibre optic cables. DWSM optical fibres shall meet the requirements defined in Table 1-1(a).



**Attenuation**

The attenuation coefficient for wavelengths between 1525 nm and 1575 nm shall not exceed the attenuation coefficient at 1550 nm by more than 0.05 dB/km. The attenuation coefficient between 1285 nm and 1330 nm shall not exceed the attenuation coefficient at 1310 nm by more than 0.05 dB/km. The attenuation of the fibre shall be distributed uniformly throughout its length such that there are no point discontinuities in excess of 0.10 dB. The fibre attenuation characteristics specified in table 1-1 (a) shall be “guaranteed” fibre attenuation of any & every fibre reel. The overall optical fibre path attenuation shall not be more than calculated below:

- Maximum attenuation @ 1550nm:  $0.21 \text{ dB/km} \times \text{total km} + 0.05 \text{ dB/splice} \times \text{no. of splices} + 0.5 \text{ dB/connector} \times \text{no. of connectors}$
- Maximum attenuation @ 1310nm:  $0.35 \text{ dB/km} \times \text{total km} + 0.05 \text{ dB/splice} \times \text{no. of splices} + 0.5 \text{ dB/connector} \times \text{no. of connectors}$

**Construction**

The OPGW (Optical Ground Wire) cable is proposed to be installed on the EHV transmission lines. The design of cable shall account for the varying operating and environmental conditions that the cable shall experience while in service. The OPGW cable to be supplied shall be designed to meet the overall requirements of all the transmission lines. The Bidder shall design the OPGW requirements to suit each span in the system, based on the applicable drawings and field surveys. The Bidder’s proposal shall stipulate the characteristics of the OPGW required for each span in the system.

**Optical Fibre Identification**

Individual optical fibres within a fibre unit and fibre units shall be identifiable in accordance with EIA/TIA 598 or IEC 60304 or Bellcore GR-20 colour-coding scheme.

Colouring utilized for colour coding optical fibres shall be integrated into the fibre coating and shall be homogenous. The colour shall not bleed from one fibre to another and shall not fade during fibre preparation for termination or splicing.

Each cable shall have traceability of each fibre back to the original fibre manufacturer's fibre number and parameters of the fibre. If more than the specified number of fibres is included in any cable, the spare fibres shall be tested by the cable manufacturer and any defective fibres shall be suitably bundled, tagged and identified at the factory by the vendor.

**Table1-1(a)**  
**DWSM Optical Fibre Characteristics**

## TECHNICAL REQUIREMENTS



Fibre Description:	Dual-Window Single-Mode
Mode Field Diameter:	8.6 to 9.5 $\mu\text{m}$ ( $\pm 0.6\mu\text{m}$ )
Cladding Diameter:	125.0 $\mu\text{m}$ $\pm 1 \mu\text{m}$
Mode field concentricity error	$\leq 0.6\mu\text{m}$
Cladding non-circularity	$\leq 1\%$
Cable Cut-off Wavelength $\lambda_{c,c}$	$\leq 1260 \text{ nm}$
1550 nm loss performance	As per ITU-T G.652 D
Proof Test Level	$\geq 0.69 \text{ Gpa}$
Attenuation Coefficient:	@ 1310 nm $\leq 0.35 \text{ dB/km}$ @ 1550 nm $\leq 0.21 \text{ dB/km}$
Chromatic Dispersion; Maximum: Zero Dispersion Wavelength: Zero Dispersion Slope:	18 ps/(nm x km) @ 1550 nm 3.5 ps/(nm x km) 1288-1339nm 5.3 ps/(nm x km) 1271-1360nm 1300 to 1324nm 0.092 ps/(nm <sup>2</sup> xkm) maximum
Polarization mode dispersion coefficient	$\leq 0.2 \text{ ps/km}^{1/2}$
Temperature Dependence:	Induced attenuation $\leq 0.05 \text{ dB}$ (-60°C - +85°C)
Bend Performance:	@ 1310 nm (75 $\pm$ 2 mm dia Mandrel), 100 turns; Attenuation Rise $\leq 0.05 \text{ dB}$ @ 1550 nm (30 $\pm$ 1 mm radius Mandrel), 100 turns; Attenuation Rise $\leq 0.05 \text{ dB}$ @ 1550 nm (32 $\pm$ 0.5 mm dia Mandrel, 1 turn; Attenuation Rise $\leq 0.50 \text{ dB}$

**Buffer Tube** Loose tube construction shall be implemented. The individually coated optical fibre(s) shall be surrounded by a buffer for protection from physical damage during fabrication, installation and operation of the cable. The fibre coating and buffer shall be strippable for splicing and termination. Each fibre unit shall be individually identifiable utilizing colour coding. Buffer tubes shall be filled with a water-blocking gel.

### Optical Fibre Strain & Sag-Tension chart

The OPGW cable shall be designed and installed such that the optical fibres experience no strain under all loading conditions defined in IS 802. Zero fibre strain condition shall apply even after a 25 year cable creep.

## TECHNICAL REQUIREMENTS



While preparing the Sag-tension charts for the OPGW cable the following conditions shall be met:

- The Max Allowable Tension (MAT) / max strain shall be less than or equal to the MWT/ Strain margin of the cable.
- The sag shall not exceed the earth wire sag in all conditions.
- The Max Allowable Tension shall also be less than or equal to 0.4 times the UTS.
- The 25 year creep at 25% of UTS (creep test as per IEEE 1138) shall be such that the 25 year creep plus the cable strain at Max Allowable Tension (MAT) is less than or equal to the cable strain margin.
- The everyday tension (EDT) shall not exceed 20% of the UTS for the OPGW cable.

2.13.01

The Sag-tension chart of OPGW cable indicating the maximum tension, cable strain and sag shall be calculated and submitted for owners review.

### Cable Materials

The materials used for optical fibre cable construction, shall meet the following requirements:

### Filling Materials

The interstices of the fibre optic unit and cable shall be filled with a suitable compound to prohibit any moisture ingress or any water longitudinal migration within the fibre optic unit or along the fibre optic cable. The water tightness of the cable shall meet or exceed the test performance criteria as per IEC 60794-1-F-5.

The filling compound used shall be a non-toxic homogenous waterproofing compound that is free of dirt and foreign matter, nonhygroscopic, electrically nonconductive and non-nutritive to fungus. The compound shall also be fully compatible with all cable components it may come in contact with and shall inhibit the generation of hydrogen within the cable.

The waterproofing filling materials shall not affect fibre coating, colour coding, or encapsulant commonly used in splice enclosures, shall be dermatologically safe, non-staining and easily removable with a non-toxic cleaning solvent.

### Metallic Members

When the fibre optic cable design incorporates metallic elements in its construction, all metallic elements shall be electrically continuous.

### Optical Ground Wire (OPGW)

OPGW cable construction shall comply with IEEE-1138, 2009. The cable provided shall meet both the construction and performance requirements such that the ground wire function, the optical fibre integrity and optical transmission characteristics are suitable for the intended purpose. The cable shall consist of optical fibre units as defined in this specification. There shall be no factory splices

within the cable structure of a continuous cable length.

The composite fibre optic overhead ground wire shall be made up of multiple buffer tubes embedded in a water tight aluminium/aluminium alloy/stainless steel with aluminium coating protective central fibre optic unit surrounded by concentric-lay stranded metallic wires in single or multiple layers. Each buffer tube shall have maximum 12 no. of fibres. All fibres in single buffer tube or directly in central fibre optic unit is not acceptable. The dual purpose of the composite cable is to provide the electrical and physical characteristics of conventional overhead ground wire while providing the optical transmission properties of optical fibre.

**Central Fibre Optic Unit**

The central fibre optic unit shall be designed to house and protect multiple buffered optical fibre units from damage due to forces such as crushing, bending, twisting, tensile stress and moisture. The central fibre optic unit and the outer stranded metallic conductors shall serve together as an integral unit to protect the optical fibres from degradation due to vibration and galloping, wind and ice loadings, wide temperature variations, lightning and fault current, as well as environmental effects which may produce hydrogen.

The OPGW design of dissimilar materials such as stainless steel tube with aluminium or aluminium –clad-steel wire strands are not allowed. Central fibre optic unit may be of aluminium or stainless steel tube with aluminium protective coating. In case of aluminium protective coating, the coating must completely cover the tubes leaving no exposed areas of tubing that can make electrical contact either directly or indirectly through moisture, contamination, protrusions, etc with the surrounding stranded wires. The tube may be fabricated as a seamless tube, seam welded, or a tube without a welded seam.

**Basic Construction**

The OPGW cable construction shall conform to the applicable requirements of this specification, applicable clauses of IEC 61089 related to stranded conductors and Table given below for OPGW Mechanical and Electrical Characteristics. In addition, the basic construction shall include bare concentric-laystranded metallic wires with the outer layer having left hand lay. The wires may be of multiple layers with a combination of various metallic wires within each layer. The direction of lay for each successive layer shall be reversed. The finished wires shall contain no joints or splices unless otherwise agreed to by the Employer and shall conform to all applicable clauses of IEC 61089 as they pertain to stranded conductors.

The wires shall be so stranded that when the complete OPGW is cut, the individual wires can be readily regrouped and then held in place by one hand.

**Breaking Strength**

The rated breaking strength of the completed OPGW shall be taken as no more than 90 percent of the sum of the rated breaking strengths of the individual wires,

<p>LARA THERMAL POWER PROJECT STAGE- II (2X800 MW) EPC PACKAGE</p>	<p>TECHNICAL SPECIFICATION SECTION – VI, PART-B</p>	<p>SUB-SECTION : B-17: SWITCHYARD</p>	<p>Page 94 of 97</p>
--	---	---	--------------------------

## TECHNICAL REQUIREMENTS



calculated from their nominal diameter and the specified minimum tensile strength.

The rated breaking strength shall not include the strength of the optical unit. The fibre optic unit shall not be considered a load bearing tension member when determining the total rated breaking strength of the composite conductor.

### Electrical and Mechanical Requirements

Below table provides OPGW Electrical and Mechanical Requirements for the minimum performance characteristics. For the purposes of determining the appropriate Max Working Tension limit for the OPGW cable IS 802:1995 and IS 875: 1987 shall be applied.

### OPGW Electrical and Mechanical Requirements

Everyday Tension	$\leq 20\%$ of UTS of OPGW
D.C. Resistance at 20°C:	$< 1.0$ ohm/Km
Short Circuit Current	$\geq 6.32$ kA for 1.0 second

Since OPGW shall be located at the top of the transmission line support structure, it will be subjected to Aeolian vibration, Galloping and Lightning strikes. It will also carry ground fault currents. Therefore, its electrical and mechanical properties shall be same or similar as those required of conventional ground conductors.

### Assemblies and Line Accessories

#### a. General

The OPGW assemblies and line accessories shall consist of the hardware indicted herein. All hardware and accessories shall be made of aluminum, aluminum alloy, malleable iron, steel (metal mold of drop forging process), stainless steel, or non-ferrous metal, unless otherwise specified. In addition, all hardware and accessories shall have an ultimate tensile strength equal to or exceeding the rated ultimate tensile strength of the overhead ground wire. All metal shall be free from burrs, sharp edges, lumps and dross and shall be smooth so that interconnecting parts will fit properly, and so that the parts maybe assembled and readily.

All bolts and other fasteners shall be installed according to manufacturer's recommendations. Materials no specifically covered herein by detailed specifications shall be of standard commercial quality suitable for the intended use. The Contractor shall determine the most suitable type of clamp to be used at each and every transmission tower location.

#### b. Suspension Clamps

The suspension clamps for the OPGW shall be of bolt or performed type. The bolt type suspension clamps shall be complete with bolts, keeper pieces, and other

## TECHNICAL REQUIREMENTS



required parts. Each clamp shall be capable of holding the OPGW without slipping under an unbalanced tension of 25% of the ultimate tensile strength of the OPGW.

### c. Tension Clamps

The tension clamps shall be of bolt or performed type, and cable of holding the OPGW without slipping or damaging the OPGW under a tension of 75% of the OPGW ultimate tensile strength. A suitable piece shall be of same material as the clamp body. Bolts, nuts and washers shall be hot-dipped galvanized malleable iron or steel.

### d. Grounding clamps and Parallel Groove Clamp

Each clamp shall be capable holding the OPGW using bolts and nuts.

### e. Vibration dampers

Stock bridge type vibration dampers, suitable for use on the OPGW shall be supplied. The dampers shall have an aluminum, clamping bolts, or other suitable device, on the galvanized wire between the weights, and be suitable for attachment to the OPGW. The damper clamp shall be designed to permit installation and removal using hot line tools. Each damper weight, subject to the accumulation of moisture, shall be provided with one drain hold positioned at the bottom of the weight when the damper is installed in the vertical plane. Damper weights shall be made of hot dip galvanized case iron or zinc.

### f. Armor rods

The armor rods for the OPGW shall be of the preformed type. They shall be smooth and free from corrosion, splitting, cracking, or any other defects. They shall be designed to effectively protect the OPGW from fatigue caused by vibration.

Armor rods may or may not be employed, as per OPGW manufacturer recommendations, however the use of armor rods is preferred by the Employer.

g. The joint box shall be air-tight, water-proof. The cover shall be securely fastened to the case by non-loosening fasteners. Both the case and the cover shall be made of non-corrosive aluminum alloy or hot dip galvanized steel or approved materials. The joint box shall be sufficiently rugged and sturdy to withstand outdoor climatic and environmental conditions. The joint box shall accommodate sheath protected arc-fusion splices and up to 1.5 m of additional fiber on each side of the splice; guides shall be provided to keep the extra fiber well above the allowable bending radius of the fiber. The spliced parts of the optical fiber within the joint box shall be reinforced and free from tension after completion of the splicing.

The contractor shall provide one set of terminating materials with every joint box for optical fiber connection.

All splices shall be encased in Fibre Optic Splice Enclosures. Suitable splice enclosures shall be provided to encase the optical cable splices in protective, moisture and dust free environment. Splice enclosures shall comply with ingress protection class IP 66 or better. The splice enclosures shall be designed for the storage and protection of required number of optical fibre splices and equipped with

**TECHNICAL REQUIREMENTS**



sufficient number of splice trays for splicing all fibres in the cable. No more than 12 fibres shall be terminated in a single splice tray. They shall be filled with suitable encapsulate that is easily removable should re-entry be required into the enclosures.

Splice enclosures shall be suitable for outdoor use with each of the cable types provided under this contract. Splice enclosures shall be appropriate for mounting on transmission line towers above anti-climb guard levels at about 10 metres from top of the tower and shall accommodate pass-through splicing. Contractor shall be responsible for splicing of fibres and installation of splice enclosures.

**15.07.04 Hot Line Maintenance**

The insulators offered shall be suitable for employment of hot line maintenance technique so that the usual hot line operations can be carried out with ease, speed and safety.

Bidders shall indicate the methods generally used in the routine hot and dead line maintenance of HV lines for which similar insulator have been supplied by them. Bidders shall also indicate the recommended periodicity of such maintenance.

**16.00.00 TESTS FOR TRANSMISSION LINE MATERIAL**

**16.01.00 GENERAL REQUIREMENTS**

**16.01.01** The materials shall conform to all the type tests as per relevant standards. The acceptance, routine tests and tests during manufacturer shall be carried out on the line material as per relevant standards.

# **SUB-SECTION-I-B**

## **PROJECT INFORMATION**

**LARA SUPER THERMAL POWER PROJECT  
STAGE-II (2X800 MW)  
EPC PACKAGE**

**TECHNICAL SPECIFICATION  
SECTION-VI, PART-A  
BID DOC NO. CS-9587-001R-2**

**1.00.00 BACKGROUND**

Lara STPP Stage-I(2X800 MW) units are in operation near Lara village in Raigarh Distt. of Chhattisgarh. The Present proposal is for Lara STPP, Stage-II (2x800 MW) as extension of existing stage-I.

**2.00.00 LOCATION AND APPROACH**

The project is located in Raigarh district of Chhattisgarh State. The project is located south-east of Raigarh town near village Lara, bounded by villages Lara, Chhapora & Lohakhan and on the western side of Odisha State boundary.

**2.01.00 RAIL LINK**

The project site is approachable from NH-200 (Raigarh–Sarangarh) via Kondatarai through State PWD Road.

The nearest rail head Raigarh Railway Station (on South East Central Railway, Howrah-Bilaspur Broad Gauge), is approximately 30 kms from the project site.

**2.02.00 AIRPORT**

The nearest commercial airport, Raipur is about 250 kms from the project site.

Vicinity Plan is placed at **Annexure-I**.

**3.00.00 CAPACITY**

Stage-I	:	1600 MW (2x800 MW) – Under Operation
Stage-II	:	1600 MW (2x800 MW) - Present proposal

**4.00.00 LAND**

About 2450 Acre of Land has been acquired for Lara Super Thermal Power Project. The expansion project is envisaged to be accommodated with in the land already acquired during Stage-I.

**5.00.00 WATER**

Water Cooled Condenser is envisaged for Lara Stage-II of 2 X 800 MW units. Make up water requirement for this project would be about 4800 Cu.M/hr.

The make-up water will be drawn from Mahanadi river. Raw water will be drawn to supply to PT Plant & Ash Handling Plant.

WRD, Govt. of Chhattisgarh have accorded Water availability confirmation of 45 MCM for Stage-I (2x800 MW) and 68 MCM for Stage-II of Lara STPP from Saradih Barrage on river Mahanadi. Thus the total committed water by WRD, Govt. of Chhattisgarh for Lara STPP is available for 113 MCM.

Closed cycle cooling water system using cooling towers is envisaged for Stage-II of the project.

CLAUSE NO.	PROJECT INFORMATION		
<p><b>6.00.00 COAL</b></p> <p><b>6.01.00</b> Coal requirement for Lara STPP, Stage-II (2x800 MW) would be about 7.0 MTPA million at 90% PLF and shall be met from Talaipalli coal blocks (Mand-Raigarh coal fields) allotted to NTPC.</p> <p><b>6.02.00 Coal Transportation</b></p> <p>The envisaged mode of coal transportation from the coal mines to the power plant is by MGR/IR in BOBR wagons.</p> <p><b>6.03.00 Coal Quality</b></p> <p>The primary fuel for the main steam generator shall be coal. The coal quality parameters are indicated in <b>Annexure-IV-2</b> are to be considered for steam generator design.</p> <p><b>7.00.00 Fuel Oil</b></p> <p>The fuel oils to be used for start-up, coal flame stabilization and low load operation of the steam generator shall be Light Diesel Oils having the characteristics given at <b>Annexure-IV-1</b>.</p> <p><b>8.00.00 MODE OF OPERATION</b> : Middle load (two shifting and load cycling)</p> <p><b>9.00.00 STEAM GENERATOR TECHNOLOGY</b></p> <p>The steam generators shall be super critical, once through, water tube type, direct pulverized coal fired, top supported, balanced draft furnace, single reheat, radiant, dry bottom type, suitable for outdoor installation. The gas path arrangement shall be single pass (Tower type) or two pass type.</p> <p><b>10.00.00 FLUE GAS DESULPHURIZATION SYSTEM (FGD) &amp; DeNOx ready System:</b></p> <p>The project is envisaged with Flue Gas Desulfurization (FGD) system and DeNOx ready System. Limestone to be used for design of FGD system shall be as per the characteristic given at <b>Annexure-IV-5</b>.</p> <p><b>11.00.00 CONSTRUCTION POWER</b></p> <p>The requirements of the construction power supply for the project would be met from the stage-I 11 kV Miscellaneous Switchgear located in Stage-I area. Necessary 11 kV interconnection, Ring main/LT sub-stations shall be provided by the bidder for the required power plant area.</p> <p><b>12.00.00 POWER EVACUATION SYSTEM</b></p> <p>LARA STPP -II shall be the extension project of LARA STPP-I (2X800 MW) and would comprise of two (2) Nos. of coal fired unit of capacity 800 MW each. Step up/power evacuation voltage of Stage-I of the project is 400KV. Under Stage-I of the project, provision of One no. 400kV twin D/C line up to Raigad Kotra pooling station has been considered for connectivity. One no. 400kV Quad D/C line to Champa pooling has also been kept for evacuation of power as finalized in Western Region Standing Committee Meeting/LTA&amp; Connectivity meeting.</p> <p>Under stage-II, two more units of 800 MW units are considered making the ultimate project capacity as 3200 MW.. A number of IPPs are coming in this vicinity of Raigarh-Korba complex of Chhattisgarh., the bulk power generated in this region</p>	 <p>A Maharatna Company</p>		
<p>LARA SUPER THERMAL POWER PROJECT STAGE-II (2X800 MW) EPC PACKAGE</p>	<p>TECHNICAL SPECIFICATION SECTION-VI, PART A</p>	<p>SUB SECTION –IB PROJECT INFORMATION</p>	<p>PAGE 2 OF 22</p>

CLAUSE NO.	PROJECT INFORMATION		
	<div style="text-align: right; margin-bottom: 10px;">   <small>A Maharashtra Company</small> </div> <p>shall be exported to power deficit region of WR and NR. Major 765 kV/400 kV pooling stations in this vicinity are being implemented by Central Transmission utility for bulk transmission of power through high capacity 765 kV and 800 kV HVDC corridors to facilitate exchange of the quantum of power from generation projects proposed to be located in eastern part of WR to Central/Western part of WR and NR. Considering above aspect, the step up/power evacuation voltage for stage-II has been considered at 400 kV.</p> <p>As elaborated above, the power generated need to be transmitted through high capacity corridors to load centers in Central/western part of WR and NR. The nearest 765/400 kV pooling station located to this project is Kotra pooling station in Raigarh. This pooling station is interconnected to other two pooling station in this vicinity i.e. Champa and Tamamar pooling station. Also Kotra pooling station is planned to be interconnected with Dhule (PG) thorough a high capacity +/- 600 kV HVDC corridor under common regional transmission system strengthening. Considering overall scenario, presently 4 nos. of 400 kV line bays have been kept in the Generation Switchyard for connecting to 400 kV Raigarh (Kotra) pooling station. 400kV D/C Twin Moose Lara-I-Raigarh (Kotra) line is already available in stage-I. It is proposed to upgrade this line to Quad capacity and use it for evacuation of power from stage-II. However, in line with CERC regulation on Grant of Connectivity, Long term Access (LTA) and Medium term open access in Inter State Transmission System (ISTS) and related matter, connectivity and LTA application shall be submitted to Power Grid (CTU) for finalization of ISTS connectivity and Associated Transmission System (ATS) of the project.</p> <p>Based on Connectivity &amp; LTA applications indicating beneficiaries, the ATS would be finalized by Central Transmission Utility (PGCIL) /CEA in the regional Standing Committee Meeting/LTA &amp; Connectivity meeting</p> <p><b>13.00.00 PLANT WATER SCHEME</b></p> <p><b>13.01.00 Equipment Cooling Water (ECW) System (Unit Auxiliaries)</b></p> <p>All plant auxiliaries and station auxiliaries shall be cooled by De-mineralized water (DM) in a closed circuit. The primary circuit DM water shall be cooled through plate type heat exchangers by Circulating Water tapped from CW system in a closed secondary circuit.</p> <p>It is proposed to provide independent primary cooling water circuit for TG &amp; its auxiliaries and Steam Generator &amp; auxiliaries (including FGD &amp; station auxiliaries) on Unit basis.</p> <p><b>13.02.00 Other Miscellaneous Water Systems</b></p> <p>CW system blow down water shall be used in Ash Handling System, FGD process water and CHP dust suppression, service water etc. (Refer Plant Water Scheme). Further, the plant service water requirement, sealing of Vacuum pumps (if applicable) of Ash Handling plant, make-up to fire water system, APH wash &amp; FGD system (gypsum cake wash) make up shall be met from PT plant of CW system (PT-CW). The waste service water collected from various areas and coal-laden water from coal handling plant shall be treated as per requirement and reused.</p> <p>The quality of Raw water, &amp; DM water is given in this sub-section at <b>Annexure-III-A, and IIIB.</b></p>		
<p>LARA SUPER THERMAL POWER PROJECT STAGE-II (2X800 MW) EPC PACKAGE</p>	<p>TECHNICAL SPECIFICATION SECTION-VI, PART A</p>	<p>SUB SECTION –IB PROJECT INFORMATION</p>	<p>PAGE 3 OF 22</p>

CLAUSE NO.	PROJECT INFORMATION		
<p><b>13.03.00</b></p> <p><b>14.00.00</b></p> <p><b>16.00.00</b></p> <p><b>17.00.00</b></p> <p><b>18.00.00</b></p> <p><b>19.00.00</b></p>	<p><b>Condenser Cooling (CW) Water System</b></p> <p>It is proposed to adopt a recirculating type cooling water system with Induced Draft type cooling towers for the project. For the re-circulating type CW system it is proposed to supply clarified water as make up. Circulating water from CW pumps to TG area and from TG area to cooling tower will be carried through pipes/ducts. Cooled water from Cooling Tower will be led to CW pump house through the cold water channel by gravity.</p> <p>Plant water scheme is included in <b>Part-E</b> of the technical specification.</p> <p><b>ENVIRONMENTAL ASPECTS</b></p> <p>Lara STPP, Stage-II is proposed to be constructed on the land already acquired for ultimate capacity of Lara STPP, which conforms to the siting criteria for thermal power plants. Environment and Forest Clearances for Lara STPP Stage-I have already been accorded by MoEF&amp;CC.</p> <p><b>METEOROLOGICAL DATA</b></p> <p>The meteorological data from nearest observatory is placed at <b>Annexure-II</b>.</p> <p><b>CRITERIA FOR EARTHQUAKE RESISTANT DESIGN OF STRUCTURES AND EQUIPMENT</b></p> <p>All power plant structures and equipment, including plant auxiliary structures and equipment shall be designed for seismic forces as given in Part-B of this section.</p> <p><b>CRITERIA FOR WIND RESISTANT DESIGN OF STRUCTURES AND EQUIPMENT</b></p> <p>All structures and equipment of the power plant, including plant auxiliary structures and equipment, shall be designed for wind forces as given as given in Part-B of this section</p> <p>Vulnerability Atlas of India(VAI), prepared by Building Materials, Training and Promotion Council (BMTPC) under Ministry of Housing and Urban Affairs, is a comprehensive document which provides existing hazard scenario for the entire country and presents the digitized State/UT-wise hazard, maps with respect to earthquakes, winds and floods for district-wise identification of vulnerable areas. It also includes additional digitized maps for thunderstorms, cyclones and landslides. The main purpose of this Atlas is its use for disaster preparedness and mitigation at policy planning and project formulation and construction stage. The VAI provides necessary information for risk analysis and hazard assessment and is available at website <a href="http://www.bmtpc.org">www.bmtpc.org</a>.</p> <p>As per Government's directive, it is mandatory for the bidders to refer VAI for multi-hazard risk assessment and include the relevant hazard proneness specific to project location while planning, designing and execution of the project in terms of following details:</p> <ul style="list-style-type: none"> <li>i) Seismic zone (II to V) for earthquakes</li> <li>ii) Wind velocity</li> <li>iii) Area liable to floods and Probable max. surge height</li> <li>iv) Thunderstorms history</li> <li>v) Number of cyclone storms/sever cyclone storms and max sustained wind specific to coastal region</li> <li>vi) Landslides incidences with Annual rainfall normal</li> <li>vii) District wise Probable Max. Precipitation</li> </ul>	 <p>A Maharatna Company</p>	
<p>LARA SUPER THERMAL POWER PROJECT STAGE-II (2X800 MW) EPC PACKAGE</p>	<p>TECHNICAL SPECIFICATION SECTION-VI, PART A</p>	<p>SUB SECTION –IB PROJECT INFORMATION</p>	<p>PAGE 4 OF 22</p>

CLAUSE NO.	PROJECT INFORMATION		
	<div data-bbox="1279 100 1414 180" style="text-align: right;">    <small>A Maharatna Company</small> </div> <p>Accordingly, bidder should refer VAI while planning, designing and execution of the project.</p> <p>However, for design of structures/facilities and equipment, the criteria for earthquake resistant design of structures and equipment, the criteria for Wind Resistant Design of Structures and Equipment and design parameters for drainage facilities, stipulated in the Technical Specification shall be followed.</p> <p>For other information like area liable to floods, probable max. surge height, landslide, thunderstorm, cyclone etc. agencies are required to refer the VAI.</p>		
<p style="text-align: center;"><b>LARA SUPER THERMAL POWER PROJECT STAGE-II (2X800 MW) EPC PACKAGE</b></p>	<p style="text-align: center;"><b>TECHNICAL SPECIFICATION SECTION-VI, PART A</b></p>	<p style="text-align: center;"><b>SUB SECTION –IB PROJECT INFORMATION</b></p>	<p style="text-align: center;"><b>PAGE 5 OF 22</b></p>

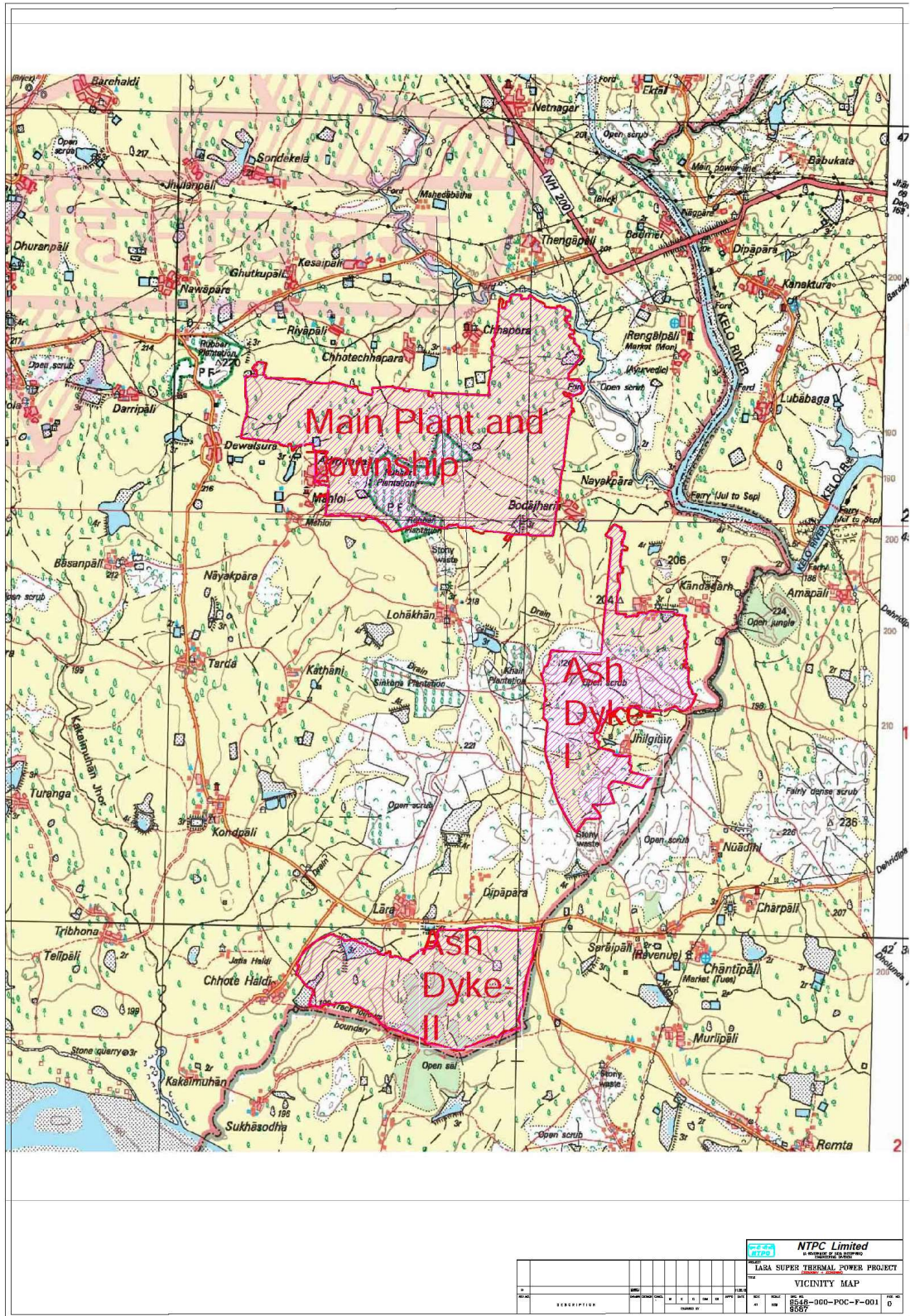





**RAW WATER ANALYSIS**

SI No.	Parameters	Unit	Results	Suggested By COS-Chem
1	pH		8.0	8.2
2	Turbidity	NTU	84	500
3	P-Alkalinity	mg/l as CaCO <sub>3</sub>	nil	--
4	M-Alkalinity	mg/l as CaCO <sub>3</sub>	108	149
5	Total Hardness	mg/l as CaCO <sub>3</sub>	164	216
6	Calcium	mg/l as CaCO <sub>3</sub>	100	132
7	Magnesium	mg/l as CaCO <sub>3</sub>	64	84
8	Chloride	mg/l as Cl	28	40
9	Sulphate	mg/l as SO <sub>4</sub>	80	84
10	Total Silica	mg/l as SiO <sub>2</sub>	14.4	24.6
11	Colloidal Silica	mg/l as SiO <sub>2</sub>	6.3	4.8
12	Reactive Silica	mg/l as SiO <sub>2</sub>	8.4	19.8
13	Sodium + Potassium	mg/l as Na	52	56
14	Total Organic Carbon (TOC)	mg/l	7.2	5
15	Chemical Oxygen Demand (COD)	mg/l	12	15
16	Biological Oxygen Demand (BOD)	mg/l	3.8	5
17	Equivalent Mineral Acid (EMA)	mg/l	98	124
18	Total Suspended Solids (TSS)	mg/l	78	
19	Total Iron	mg/l as Fe	0.56	0.92
20	KMnO <sub>4</sub> No.	mg/l	1.6	2.8
21	Dissolved Oxygen (DO)	mg/l	7	7-8
22	Temperature	Deg C	29	28-36
23	TDS	ppm		307
24	Total cations	mg/l as CaCO <sub>3</sub>	216	272
25	Total anions	mg/l as CaCO <sub>3</sub>	216	272

## ANNEXURE-III B

## ANALYSIS OF DM WATER TO BE USED FOR MAKE-UP WATER TO CONDENSER

Sl.No.	Characteristics	Value
1.	Silica (Max.)	0.02 ppm as SiO <sub>2</sub>
2.	Iron as Fe	Nil
3.	Total hardness	Nil
4.	pH value	6.8 to 7.2
5.	Conductivity	Not more than 0.1 $\mu$ s/cm

## ANNEXURE-IV-1

**LIGHT DIESEL OIL CHARACTERISTICS****AS PER IS 15770-2008**

<b>Characteristics</b>	<b>LDO</b>
1. Pour Point (max)	21 °C & 12°C for Summer and Winter respectively
2. Kinematic viscosity in centistokes at 40 deg.C	2.5 to 15.0
3. Sediment percent by mass (max)	0.10
4. Total sulphur percent by mass (max)	1.5
5. Ash percentage by mass (max)	0.02
6. Carbon residue (Rams bottom) percent by pass (max.)	1.50
7. Acidity inorganic	Nil
8. Flash point (Min.) - Pensky Martens	66 deg.C
9. Copper strip corrosion for 3 hours at 100°C	Not worse than No. 2
10. Water content, % by volume (max)	0.25
11. GCV(kcal/kg)	10,000

S.No,	Characteristics (as received basis)	Range of 95 % coal supplies			Range of 5 % coal supplies	
		Column - 1	Column -2	Column - 3	Worst	Best
1.0	PROXIMATE ANALYSIS	Design	Worst	Best	Worst	Best
1.1	Total Moisture() %	15	17	17	Later	
1.2	Ash (%)	40	43	39.27		
1.3	Volatile Matter (%)	21	19	18.32		
1.4	Fixed Carbon (%)	24	21	25.41		
1.5	Total	100	100	100		
2.0	ULTIMATE ANALYSIS					
2.1	Carbon (%)	33.64	30.4	32.6	Later	
2.2	Hydrogen (%)	3.1	2.3	3.8		
2.3	Sulphur (%)	0.4	0.5	0.47		
2.4	Nitrogen (%)	1.2	0.9	0.46		
2.5	Oxygen (%)(By difference)	6.62	5.84	6.17		
2.8	Total Moisture (%)	15	17	17		
2.9	Ash (%)	40	43	39.27		
2.10	Chloride (%)	0.04	0.06			
	Total	100	100	100		
2.11	GCV (Kcal/Kg)	3500	3000	3645		
2.12	Hard Grove Index	50	48	54		
2.13	YGP (mg/Kg)	75	80	-		

3.0	ASH ANALYSIS				
3.1	Silica (%)	58.59	56.81	64.8	Later
3.2	Alumina (%)	26.77	27.42	24.21	
3.3	Iron Oxide (%)	8.8	9.8	6.29	
3.4	Titania	1.66	1.78	1.89	
3.5	Phosphoric Anhydride (%)	0.19	0.1	0.15	
3.6	Lime (%)	1.38	1.48	0.22	
3.7	Magnesia (%)	1.0	1.13	0.82	
3.8	Sulphuric Anhydride (%)	0.05	0.04	0.43	
3.9	Na <sub>2</sub> O	0.1	0.08	1.19	
3.9	K <sub>2</sub> O (by difference)	1.46	1.36		
	Total	100	100	100	
4.0	ASH FUSION RANGE				
	REDUCING ATMOSPHERE				
4.1	Initial Deformation Temp. (°C)	1150	1100	-	Later
4.2	Hemispherical Temp. (°C)	1300	1250	-	
4.3	Fusion Temperature (°C)	1400	1400	-	

Note: For FGD design and guarantee condition-HCL (ppm), wet-45 & HF (ppm) wet-12 may be considered respectively.

## METHANOL CHARACTERISTICS

SN	Fuel Property	Unit	Methanol
1	Chemical Formula		CH <sub>3</sub> -OH
2	Fuel Carbon	Wt%	38
3	Fuel Oxygen	Wt%	12
4	Density at 20 deg C	kg/m <sup>3</sup>	792
5	LHV	Kcal/kg	4800
6	Boiling Temp	°C at 1 bar	65
7	Vapour Pressure	bar at 20°C	0.13
8	Kinematic viscosity	cSt at 20°C	0.74
11	Auto Ignition	°C	470
12	Heat of Vapourization	kcal/kg	260
15	Flammability limit	vol %	6-36
16	Flash Point	°C	12

S.N.	Technical Data	Unit	Specifications for Torrefied Pellet
1.	Base Material		<b>Agro residue:</b> Which means the leftover portion of the agriculture produce such as stubble/straw/stalk/husk of those agro residue which are surplus and not being used as animal fodder such as paddy, soya, arhar, gwar, cotton, gram, jawar, bajara, moong, mustard, seasam, til, maize, sunflower, jute, coffee etc., groundnut shell, coconut shell, castor seed shell etc., pine needle, elephant grass, sarkanda and horticulture waste such as dry leaves and trimmings generated during the maintenance and pruning of trees and plants. Wood obtained from tree cutting shall not be treated as agro residue and shall be not to be used as base material or mixing purpose whatsoever.
2.	Diameter	mm	In case of cylindrical shape: Diameter: Not more than 35 mm Length: Random For other shapes: No dimension should exceed 35 mm.
3.	Fines % (<3 mm) (ARB*)	Wt%	fines ≤ 5%
4.	Gross Calorific Value (GCVARB*)	Kcal/Kg	<b>Refer below</b>
5.	Moisture (ARB*)	Wt%	≤ 15% (not more than 15%)
6.	Bulk density	Kg <sup>3</sup>	600

\*ARB – As Received Basis

The sample was prepared by torrefying rice straw at 300 deg C with a holding time of one hour. Following analysis are carried out at NETRA using the powdered torrefied rice straw samples and the results of various testing for the specific sample is tabulated below:

a. Proximate Analysis (wt %, Air Dried Basis )

M	Ash	VM	FC
6.68	21.66	47.68	23.98

b. Ultimate Analysis (wt %, Air Dried Basis)

C	H	N	S	O
46.65	3.93	1.13	0.14	19.81

c. GCV : 4201 kcal/kg

d. Ash Fusion Temperature under reducing conditions: °C

IDT	ST	HT	FT
1134	1357	1374	1422

e. Ash Elemental Analysis (Elements expressed as Oxides in %w/w)

Na2O	MgO	Al2O3	SiO2	P2O5	SO3	K2O	CaO	TiO2	MnO	Fe2O3
2.423	7.783	4.623	67.48	1.9	1.9	6.15	4.21	0.39	0.03	2.83

CLAUSE NO.	PROJECT INFORMATION		
	<div style="text-align: right;">   <small>A Maharatna Company</small> </div> <p style="text-align: right;"><b>Annexure-IV-7(C)</b></p> <p>For the Torrefied Rice Straw Pellets (Prepared by torrefaction of rice straw at 300 deg C with holding time of 1 hr) tested at NETRA, the test results are as follows:</p> <p>A. For Anion (ISO 16994:2016 E-Solid Biofuels- Determination of total content of sulphur and chlorine)-reported as wt % dry basis</p> <p style="margin-left: 40px;">a. Chlorine (Cl): 0.32%</p> <p style="margin-left: 40px;">b. Fluorine (F) : 0.09%</p> <p>B. For Cation (ISO 16967:2015 E-Solid Biofuels- Determination of major elements ...)- Reported as wt % dry basis</p> <p style="margin-left: 40px;">a. Sodium (Na): 0.31%</p> <p style="margin-left: 40px;">b. Potassium (K): 2.04%</p> <p>Note: The above details as at Annexure-IV-7(A), IV-7(B &amp; IV-7(C) are indicative only and shall vary based on the exact raw material and its subsequent processing.</p>		
<p style="text-align: center;"><b>LARA SUPER THERMAL POWER PROJECT STAGE-II (2X800 MW) EPC PACKAGE</b></p>	<p style="text-align: center;"><b>TECHNICAL SPECIFICATION SECTION-VI, PART A</b></p>	<p style="text-align: center;"><b>SUB SECTION –IB PROJECT INFORMATION</b></p>	<p style="text-align: center;"><b>PAGE 17 OF 22</b></p>

ANNEXURE-IV-1

**HIGH SPEED DIESEL OIL CHARACTERISTICS**

**[AS PER IS 1460-2005 (BS-II)]**

S. No.	Particulars	Unit	Value
1.	PHYSICAL PROPERTIES		
	a. Distillation volume recovery @ 350 <sup>0</sup> C	% vol. (min)	85
		% vol. (min)	95
	b. Distillation volume recovery @ 370 <sup>0</sup> C	cSt	2.0 – 5.0
		kg/m <sup>3</sup>	820 – 860
	c. Kinematic Viscosity @ 40 Degree C	Degree C	15
	d. Density @ 15 Degree C	(max)	03
	e. Pour Point	Degree C	
	- Summer	(max)	18
	- Winter		06
	f. Cold Filter Plugging Point	Degree C	35
	- Summer	(max)	460
	- Winter	Degree C	
	g. Flash Point (Abal)	(max)	
	h. Lubricity WSD 1.4 @ 60 Degree C	Degree C	
		(max)	
		Microns (max)	
2.	HEATING VALUE		
	a. Higher Heating Value (HHV)	Kcal/Kg	11,000
	b. Lower Heating Value (LHV)	Kcal/Kg	10,300
3.	ACIDITY		
	a. Inorganic	mg KOH/g	Nil
	b. Total	mg KOH/g	0.2 (max.)
4.	Copper Strip Corrosion 3 hours @100 <sup>0</sup> C	No.	1 (max)
5.	RCR on 10% residue	% wt.	0.3 (max)
6.	CONTAMINANTS		
	a. Ash	ppm (wt.)	100 (max)
	b. Sediments	% wt	0.05
	c. Total Sulphur	% wt	(max)
	d. Water Content	% volume	0.05
	e. Trace Metals		(max)

CLAUSE NO.

PROJECT INFORMATION



	- Na + K	ppm (wt)	0.05
	- Vanadium	ppm (wt)	(max)
	- Lead	ppm (wt)	
	- Calcium	ppm (wt)	0.30
	- Ni + Zn	ppm (wt)	(max)
			0.50
			(max)
			0.50
			(max)
			2.0
			Nil
7.	Nitrogen content (FBN)	% wt.	0.015

## TYPICAL IMPORTED COAL AND ASH CHARACTERISTICS

Sl.No.	Characteristics	Imported Coal	
		Worst	Best
	(as received basis)		
<b>1.0</b>	<b>Proximate Analysis</b>		
1.1	Total Moisture (%)	20	16
1.2	Ash (%)	10	10
1.3	Volatile Matter (%)	30	45
1.4	Fixed Carbon (%)	40	29
1.5	Total (%)	100	100
<b>2.0</b>	<b>Ultimate Analysis</b>		
2.1	Carbon (%)	56.4	62.4
2.2	Hydrogen (%)	4.5	4.9
2.3	Sulphur (%)	0.9	0.8
2.4	Nitrogen (%)	0.9	0.5
2.5	Oxygen (%) (By difference)	7.3	5.4
2.6	Carbonates (%)	0	0
2.7	Phosphorous (%)	0	0
2.8	Total Moisture (%)	20	16
2.9	Ash (%)	10	10
	Total	100	100
2.10	GCV (Kcal/Kg)	5800	6500
2.11	Hard Grove Index	45	60
2.12	YGP (mg/kg)	100	70
<b>3.0</b>	<b>Ash Analysis</b>		

3.1	Silica (SiO <sub>2</sub> ) (%)	32.74	34.94
3.2	Alumina(Al <sub>2</sub> O <sub>3</sub> ) (%)	30.5	28.43
3.3	Iron Oxides(Fe <sub>2</sub> O <sub>3</sub> ) (%)	18.2	15.2
3.4	Titania (TiO <sub>2</sub> )	1.56	1.76
3.5	Phosphoric Anhydride(P <sub>2</sub> O <sub>5</sub> ) (%)	0.44	0.54
3.6	Lime (CaO) (%)	6.12	7.62
3.7	Magnesia (MgO) (%)	1.83	1.93
3.8	Sulphuric Anhydride (%)	6.95	7.65
3.9	Sodium Oxide (Na <sub>2</sub> O) (%)	0.3	0.4
3.10	Balance alkalies (by difference)	1.36	1.56
	Total	100	100
<b>4.0</b>	<b>Ash Fusion Temperature</b>		
	<b>reducing temperature</b>		
4.1	Initial deformation Temp ( °C)	1100	1250
4.2	Hemispherical Temp. ( °C)	1300	1350
4.3	Flow Temp. ( °C)	1400	1400

## ANNEXURE-IV-5

## LIMESTONE CHARACTERISTICS

Chemical Analysis (% by mass)			
1.	CaO	%	47-51.0*
2.	MgO	%	0.9-2.0
3.	Fe <sub>2</sub> O <sub>3</sub>	%	0.45-1.0
4.	Al <sub>2</sub> O <sub>3</sub>	%	1.19-2.1
5.	Si <sub>2</sub> O <sub>3</sub>	%	2.1-4.5
6.	Mn <sub>2</sub> O <sub>3</sub>	%	<0.12
7.	P <sub>2</sub> O <sub>5</sub>	%	Traces
8.	Cl <sub>2</sub>	%	<0.015
9.	Na <sub>2</sub> O	%	<0.16
10.	K <sub>2</sub> O	%	<0.01
11.	TiO <sub>2</sub>	%	<0.02
12.	Total Sulphur	%	<0.1
13.	LOI	%	39.0-41.3
Physical Properties			
1.	Bond Index	kWh/sh.T	13
2.	Granule Size		Medium

**Notes:**

- \*Guaranteed parameters (guarantee on limestone consumption, auxiliary power consumption & gypsum purity) shall be based on available (reactive) CaCO<sub>3</sub> content of 89%. The design of Flue Gas Desulphurisation (FGD) system & auxiliaries shall be based on available (reactive) CaCO<sub>3</sub> content of 79%.
- For the purpose of volumetric computations of limestone handling & storage system the bulk density of limestone shall be taken as 1400 kg/m<sup>3</sup>. However for torque, drive & structural load requirements the density of lime stone shall be taken as 1700 kg/m<sup>3</sup>. For gypsum, the bulk density shall be taken as 900 kg/m<sup>3</sup> for volumetric computation and 1250 kg/m<sup>3</sup> for torque, drive & structural load requirements.
- For the purpose of sizing of equipments and guarantee, MgCO<sub>3</sub> shall be considered as unreactive dolomitic form.
- The above represent limestone quality to be considered for basic sizing and guarantees. Further the bidder is required to collect limestone samples from site for analysing is characteristic including reactivity. Bidder shall indicate in its bid the quantity of limestone required for such testing.

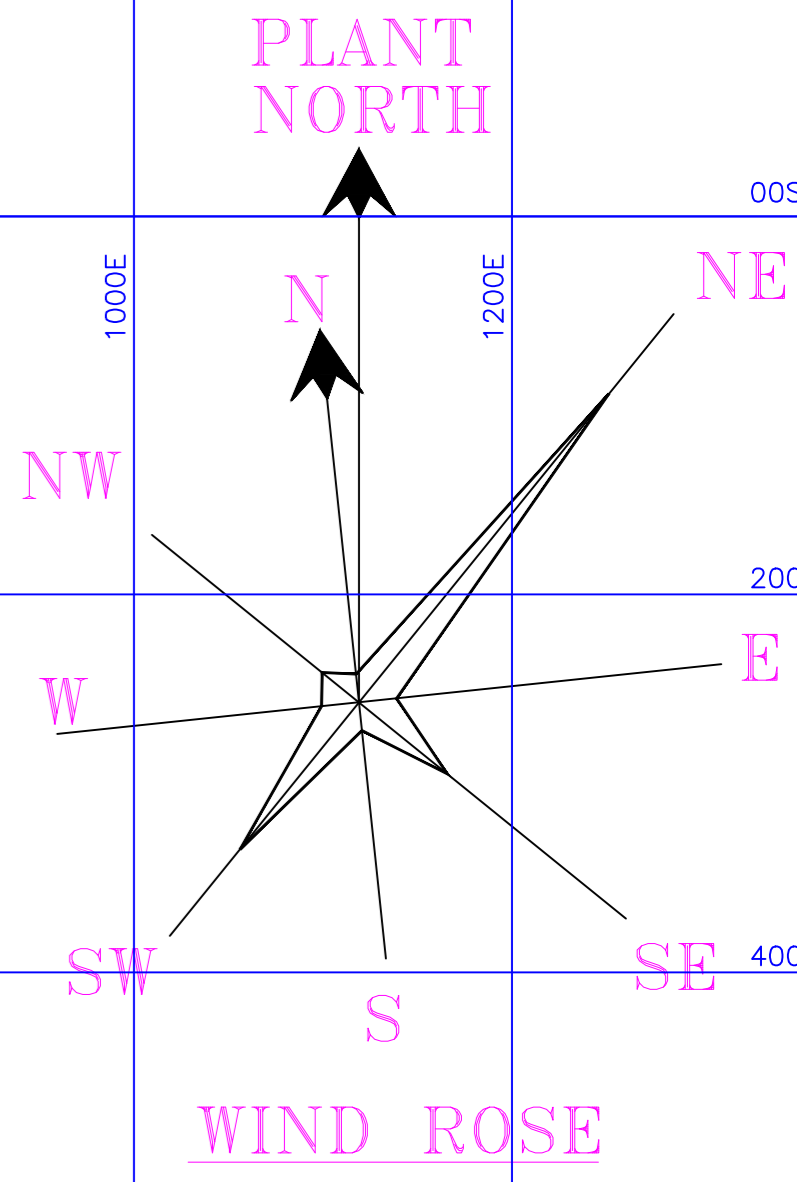
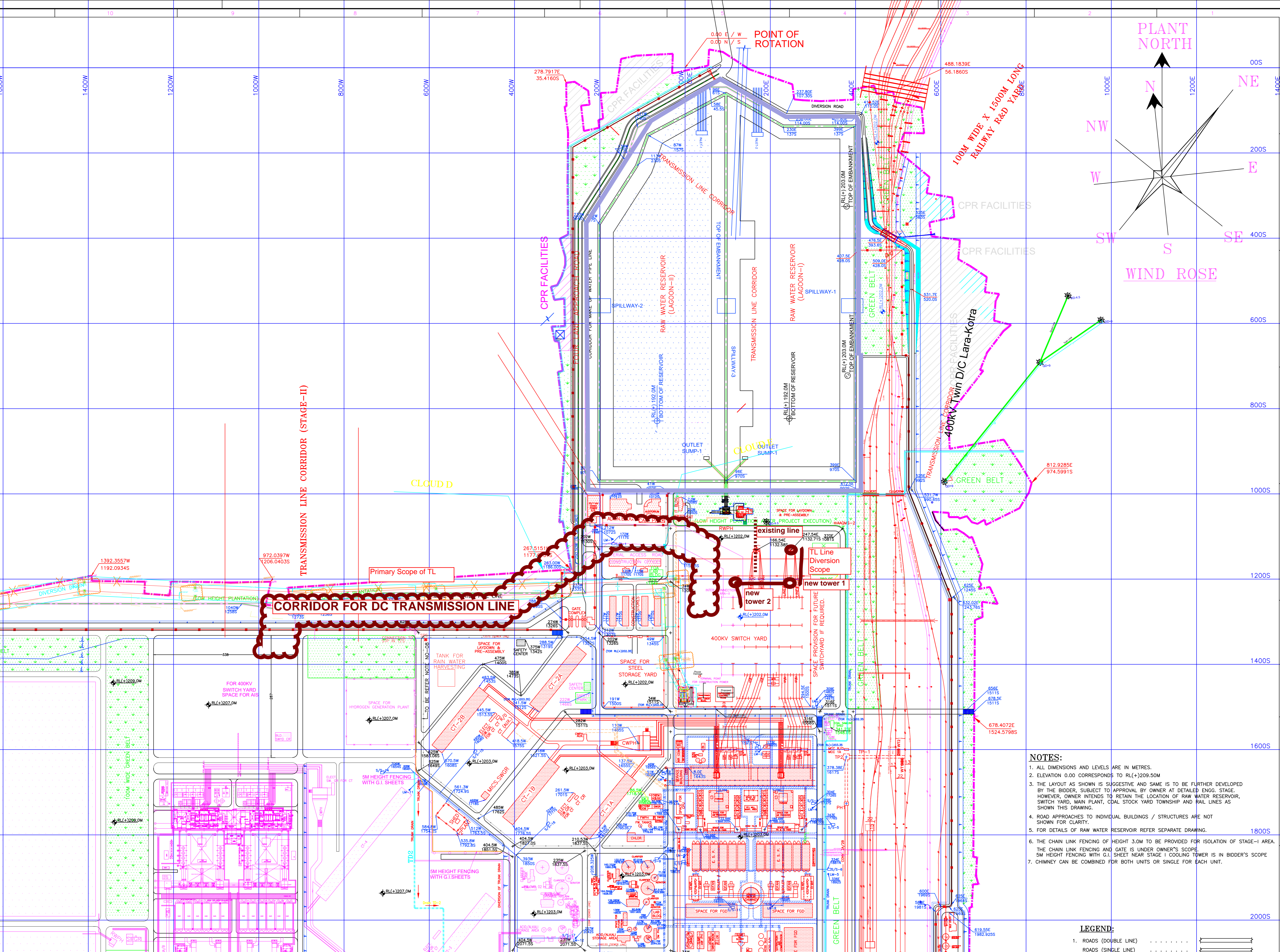

**CORRIDOR FOR DC TRANSMISSION LINE**

Primary Scope of TL

TRANSMISSION LINE CORRIDOR (STAGE-II)

POINT OF ROTATION

100M WIDE X 1500M LONG RAILWAY R&D YARD

400KV Twin DIC Lara-Kotra

existing line

TL Line Diversion Scope

new tower 1

new tower 2

- NOTES:**
1. ALL DIMENSIONS AND LEVELS ARE IN METRES.
  2. ELEVATION 0.00 CORRESPONDS TO RL(+209.50M)
  3. THE LAYOUT AS SHOWN IS SUGGESTIVE AND SAME IS TO BE FURTHER DEVELOPED BY THE BIDDER, SUBJECT TO APPROVAL BY OWNER AT DETAILED ENGG. STAGE. HOWEVER, OWNER INTENDS TO RETAIN THE LOCATION OF RAW WATER RESERVOIR, SWITCH YARD, MAIN PLANT, COAL STOCK YARD TOWNSHIP AND RAIL LINES AS SHOWN THIS DRAWING.
  4. ROAD APPROACHES TO INDIVIDUAL BUILDINGS / STRUCTURES ARE NOT SHOWN FOR CLARITY.
  5. FOR DETAILS OF RAW WATER RESERVOIR REFER SEPARATE DRAWING.
  6. THE CHAIN LINK FENCING OF HEIGHT 3.0M TO BE PROVIDED FOR ISOLATION OF STAGE-I AREA. THE CHAIN LINK FENCING AND GATE IS UNDER OWNER'S SCOPE. 5M HEIGHT FENCING WITH G.I. SHEET NEAR STAGE I COOLING TOWER IS IN BIDDER'S SCOPE
  7. CHIMNEY CAN BE COMBINED FOR BOTH UNITS OR SINGLE FOR EACH UNIT.

- LEGEND:**
- 1. ROADS (DOUBLE LINE) . . . . .
  - ROADS (SINGLE LINE) . . . . .

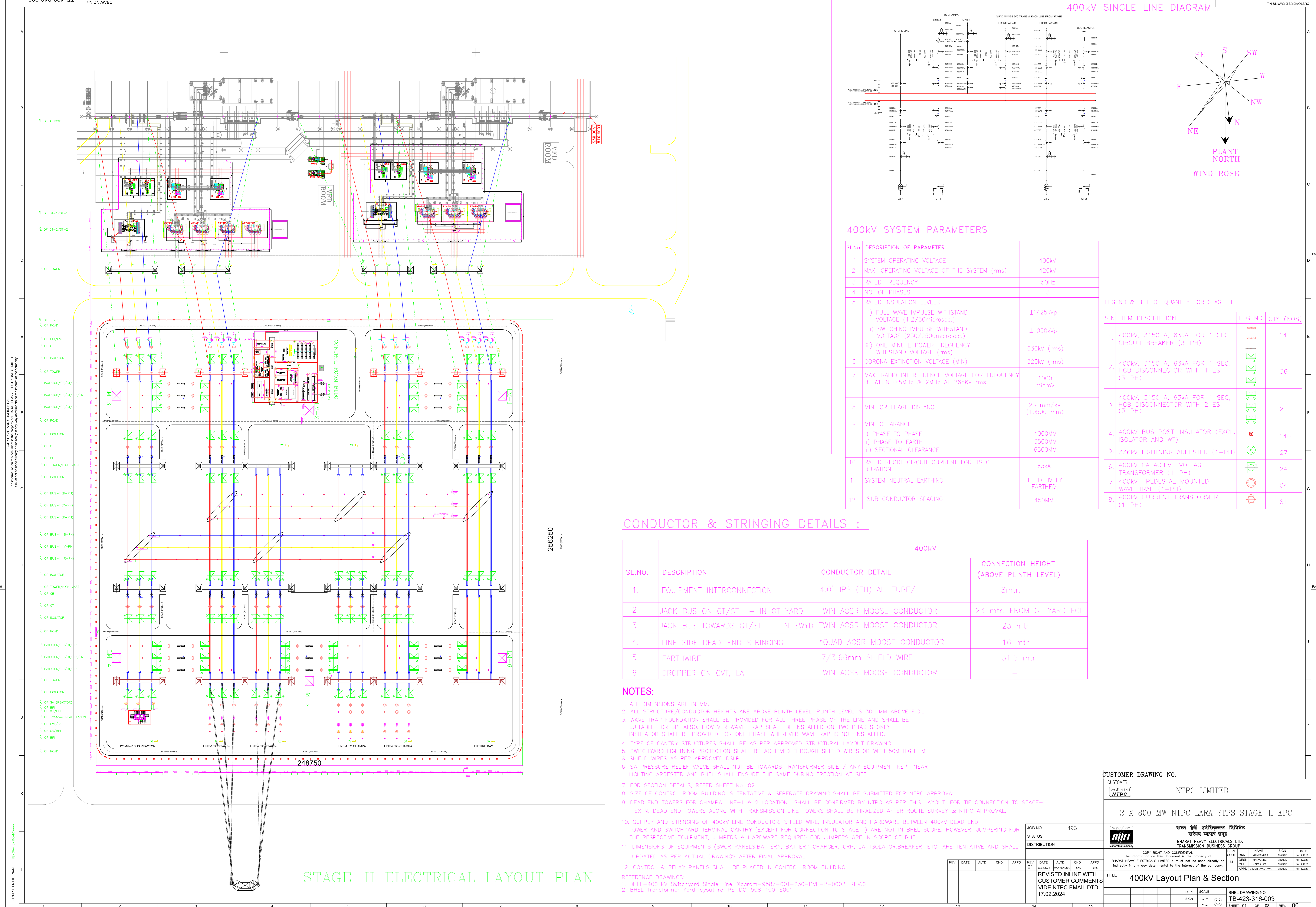

STAGE-II ELECTRICAL LAYOUT PLAN

400kV SINGLE LINE DIAGRAM

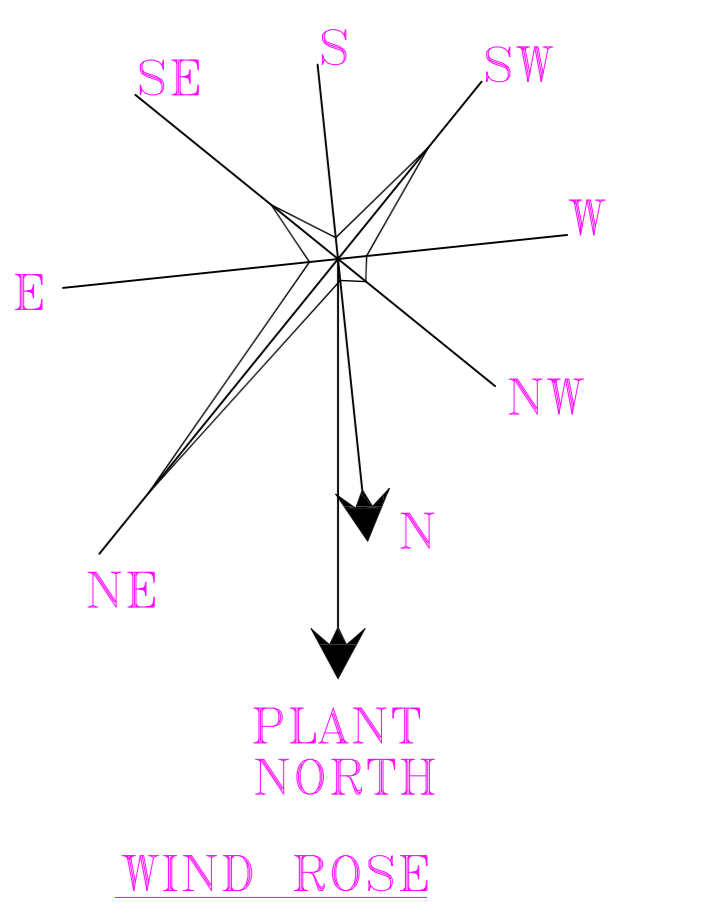
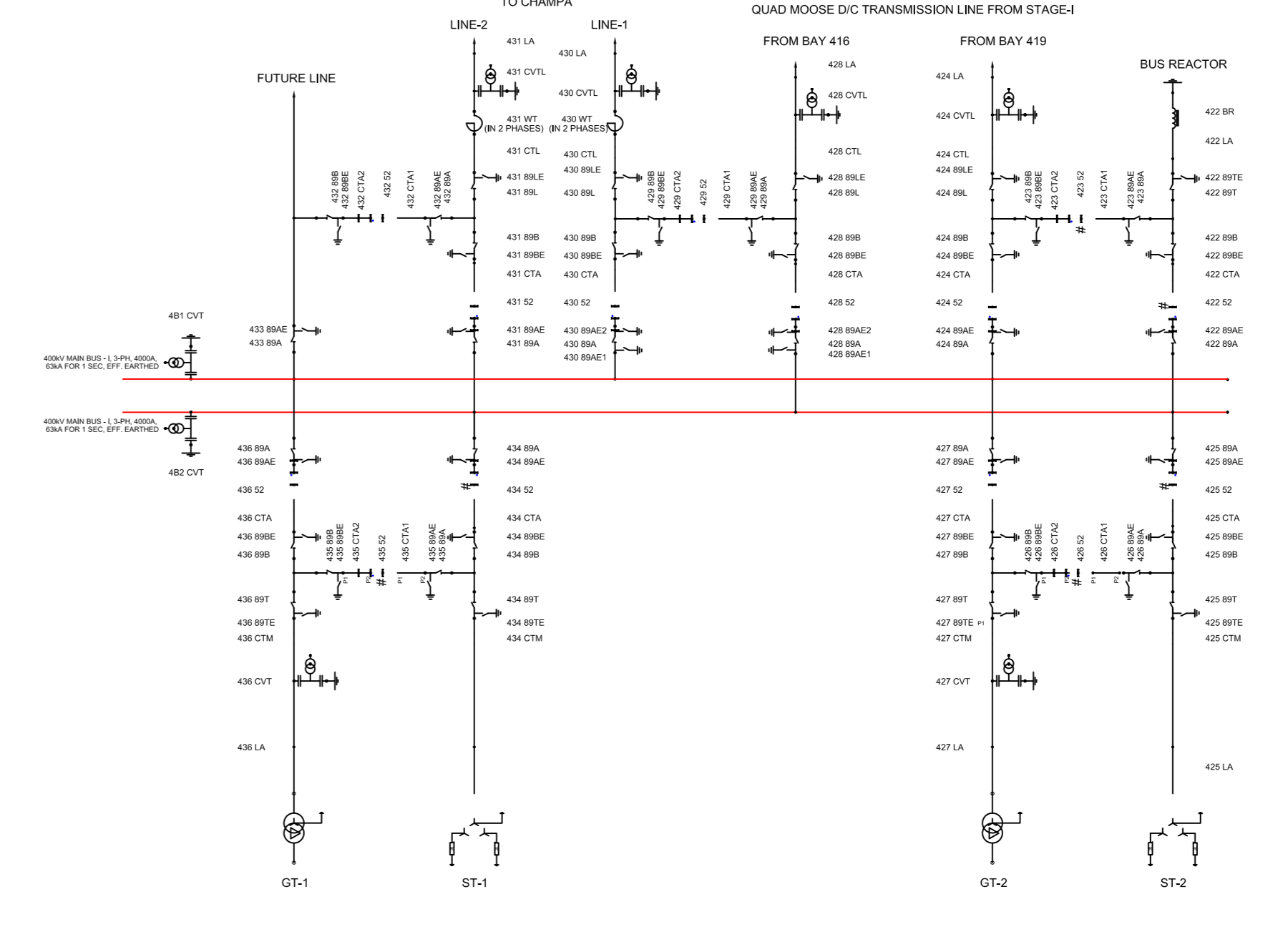

400kV SYSTEM PARAMETERS

Sl.No.	DESCRIPTION OF PARAMETER	
1	SYSTEM OPERATING VOLTAGE	400kV
2	MAX. OPERATING VOLTAGE OF THE SYSTEM (rms)	420kV
3	RATED FREQUENCY	50Hz
4	NO. OF PHASES	3
5	RATED INSULATION LEVELS	
	i) FULL WAVE IMPULSE WITHSTAND VOLTAGE (1.2/50microsec.)	±1425kVp
	ii) SWITCHING IMPULSE WITHSTAND VOLTAGE (250/2500microsec.)	±1050kVp
	iii) ONE MINUTE POWER FREQUENCY WITHSTAND VOLTAGE (rms)	630kV (rms)
6	CORONA EXTINCTION VOLTAGE (MIN)	320kV (rms)
7	MAX. RADIO INTERFERENCE VOLTAGE FOR FREQUENCY BETWEEN 0.5MHz & 2MHz AT 266kV rms	1000 microV
8	MIN. CREEPAGE DISTANCE	25 mm/kV (10500 mm)
9	MIN. CLEARANCE	
	i) PHASE TO PHASE	4000MM
	ii) PHASE TO EARTH	3500MM
	iii) SECTIONAL CLEARANCE	6500MM
10	RATED SHORT CIRCUIT CURRENT FOR 1SEC DURATION	63kA
11	SYSTEM NEUTRAL EARTHING	EFFECTIVELY EARTHED
12	SUB CONDUCTOR SPACING	450MM

LEGEND & BILL OF QUANTITY FOR STAGE-II

S.N.	ITEM DESCRIPTION	LEGEND	QTY (NOS)
1.	400kV, 3150 A, 63kA FOR 1 SEC, CIRCUIT BREAKER (3-PH)		14
2.	400kV, 3150 A, 63kA FOR 1 SEC, HCB DISCONNECTOR WITH 1 ES. (3-PH)		36
3.	400kV, 3150 A, 63kA FOR 1 SEC, HCB DISCONNECTOR WITH 2 ES. (3-PH)		2
4.	400kV BUS POST INSULATOR (EXCL. ISOLATOR AND WT)		146
5.	336kV LIGHTNING ARRESTER (1-PH)		27
6.	400kV CAPACITIVE VOLTAGE TRANSFORMER (1-PH)		24
7.	400kV PEDESTAL MOUNTED WAVE TRAP (1-PH)		04
8.	400kV CURRENT TRANSFORMER (1-PH)		81

CONDUCTOR & STRINGING DETAILS :-

SL.NO.	DESCRIPTION	CONDUCTOR DETAIL	CONNECTION HEIGHT (ABOVE PLINTH LEVEL)
1.	EQUIPMENT INTERCONNECTION	4.0" IPS (EH) AL. TUBE/	8mtr.
2.	JACK BUS ON GT/ST - IN GT YARD	TWIN ACSR MOOSE CONDUCTOR	23 mtr. FROM GT YARD FGL
3.	JACK BUS TOWARDS GT/ST - IN SWYD	TWIN ACSR MOOSE CONDUCTOR	23 mtr.
4.	LINE SIDE DEAD-END STRINGING	*QUAD ACSR MOOSE CONDUCTOR	16 mtr.
5.	EARTHWIRE	7/3.66mm SHIELD WIRE	31.5 mtr
6.	DROPPER ON CVT, LA	TWIN ACSR MOOSE CONDUCTOR	-

NOTES:

- ALL DIMENSIONS ARE IN MM.
- ALL STRUCTURE/CONDUCTOR HEIGHTS ARE ABOVE PLINTH LEVEL. PLINTH LEVEL IS 300 MM ABOVE F.G.L.
- WAVE TRAP FOUNDATION SHALL BE PROVIDED FOR ALL THREE PHASE OF THE LINE AND SHALL BE SUITABLE FOR BPI ALSO. HOWEVER WAVE TRAP SHALL BE INSTALLED ON TWO PHASES ONLY. INSULATOR SHALL BE PROVIDED FOR ONE PHASE WHEREVER WAVE TRAP IS NOT INSTALLED.
- TYPE OF GANTRY STRUCTURES SHALL BE AS PER APPROVED STRUCTURAL LAYOUT DRAWING.
- SWITCHYARD LIGHTNING PROTECTION SHALL BE ACHIEVED THROUGH SHIELD WIRES OR WITH 50M HIGH LM & SHIELD WIRES AS PER APPROVED DSLP.
- SA PRESSURE RELIEF VALVE SHALL NOT BE TOWARDS TRANSFORMER SIDE / ANY EQUIPMENT KEPT NEAR LIGHTNING ARRESTER AND BHEL SHALL ENSURE THE SAME DURING ERECTION AT SITE.
- FOR SECTION DETAILS, REFER SHEET No. 02.
- SIZE OF CONTROL ROOM BUILDING IS TENTATIVE & SEPERATE DRAWING SHALL BE SUBMITTED FOR NTPC APPROVAL.
- DEAD END TOWERS FOR CHAMPA LINE-1 & 2 LOCATION SHALL BE CONFIRMED BY NTPC AS PER THIS LAYOUT, FOR TIE CONNECTION TO STAGE-I EXTN. DEAD END TOWERS ALONG WITH TRANSMISSION LINE TOWERS SHALL BE FINALIZED AFTER ROUTE SURVEY & NTPC APPROVAL.
- SUPPLY AND STRINGING OF 400kV LINE CONDUCTOR, SHIELD WIRE, INSULATOR AND HARDWARE BETWEEN 400kV DEAD END TOWER AND SWITCHYARD TERMINAL GANTRY (EXCEPT FOR CONNECTION TO STAGE-I) ARE NOT IN BHEL SCOPE. HOWEVER, JUMPERING FOR THE RESPECTIVE EQUIPMENT, JUMPERS & HARDWARE REQUIRED FOR JUMPERS ARE IN SCOPE OF BHEL.
- DIMENSIONS OF EQUIPMENTS (SWGR PANELS, BATTERY, BATTERY CHARGER, CRP, LA, ISOLATOR, BREAKER, ETC. ARE TENTATIVE AND SHALL BE UPDATED AS PER ACTUAL DRAWINGS AFTER FINAL APPROVAL.
- CONTROL & RELAY PANELS SHALL BE PLACED IN CONTROL ROOM BUILDING.

REFERENCE DRAWINGS:  
 1. BHEL-400 kV Switchyard Single Line Diagram-9587-001-230-PVE-P-0002, REV.01  
 2. BHEL Transformer Yard layout ref: PE-DG-508-100-E001

CUSTOMER DRAWING NO. NTPC LIMITED  
 2 X 800 MW NTPC LARA STPS STAGE-II EPC

भारत हेवी इलेक्ट्रिकल्स लिमिटेड  
 भारतीय भारत कम्पनी  
 BHARAT HEAVY ELECTRICALS LTD.  
 TRANSMISSION BUSINESS GROUP

DEPT: M  
 SCALE: BHEL DRAWING NO. TB-423-316-003  
 SHEET 01 OF 03 REV. 00

COPY RIGHT AND CONFIDENTIAL. The information on this document is the property of BHARAT HEAVY ELECTRICALS LIMITED. It must not be used directly or indirectly in any way detrimental to the interest of the company.



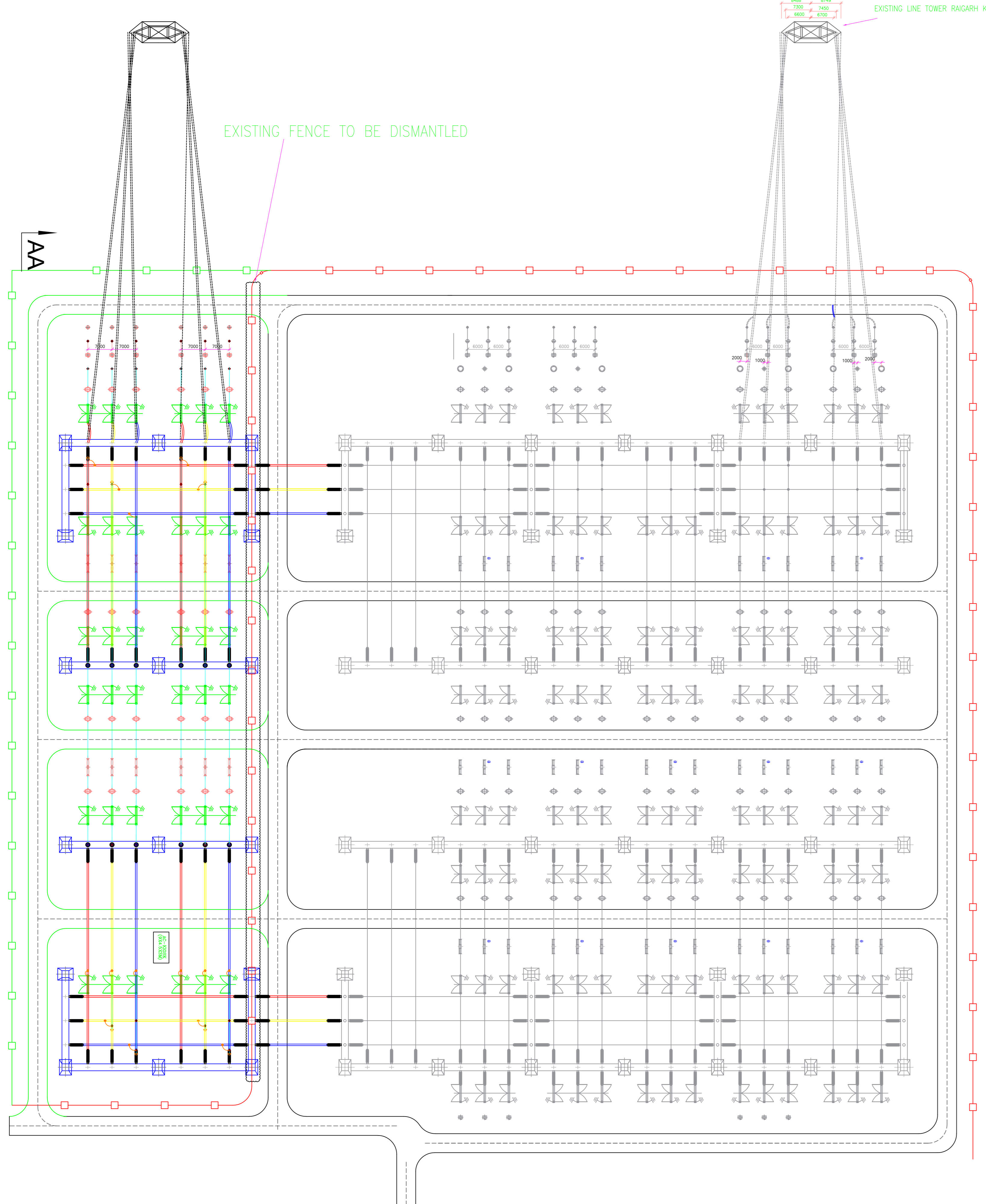

STAGE-I EXTENSION ELECTRICAL LAYOUT PLAN

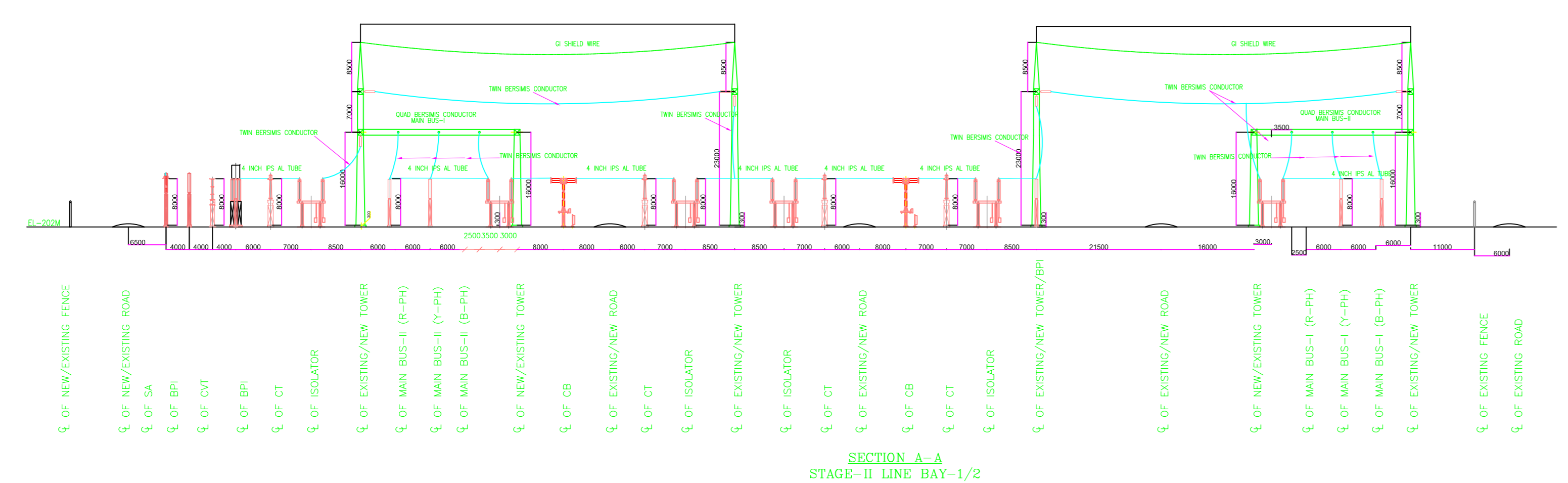

STAGE-I EXTENSION ELECTRICAL LAYOUT SECTION

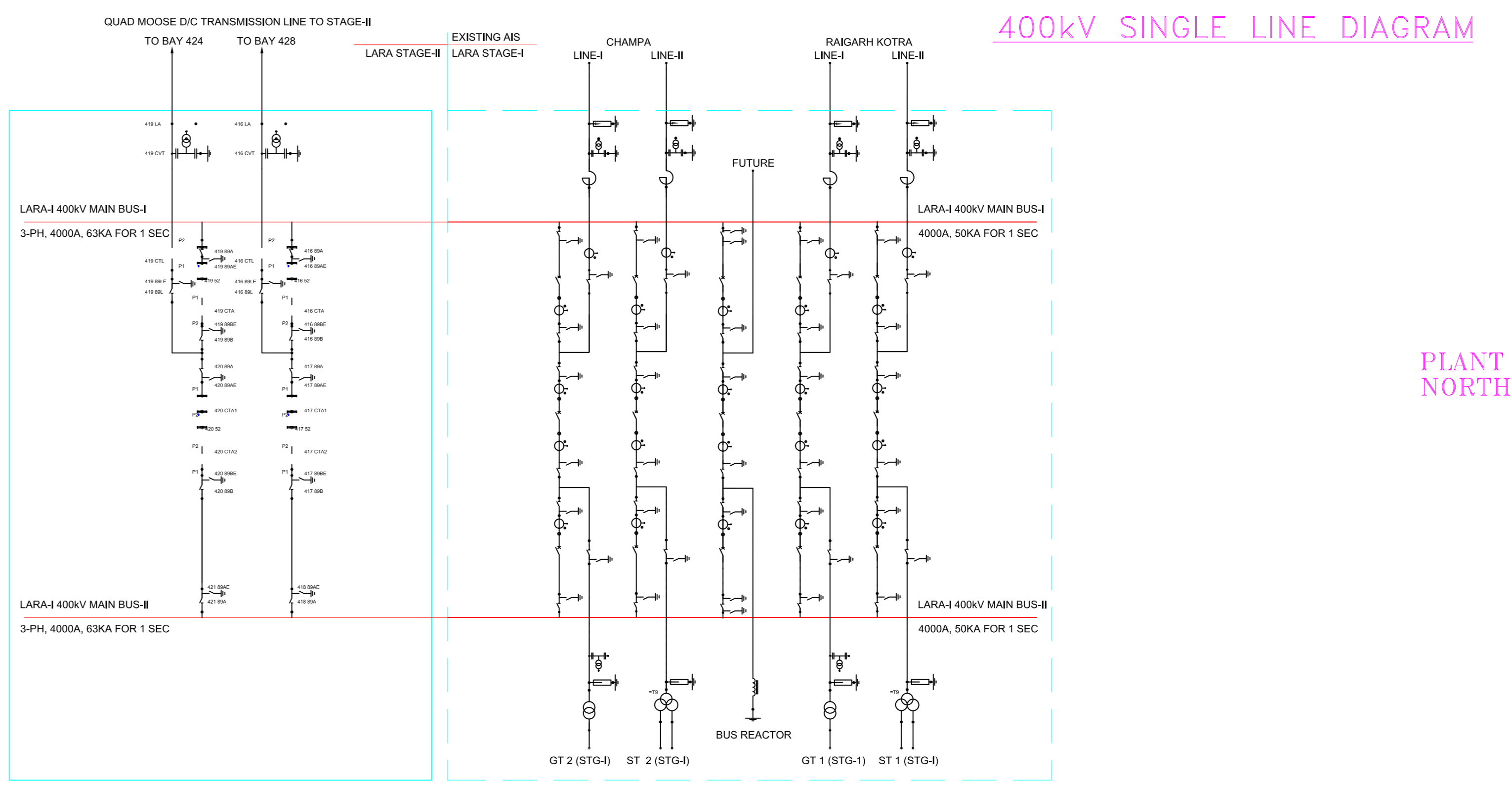

400kV SYSTEM PARAMETERS

SL.No.	DESCRIPTION OF PARAMETER	VALUE
1	SYSTEM OPERATING VOLTAGE	400kV
2	MAX. OPERATING VOLTAGE OF THE SYSTEM (rms)	420kV
3	RATED FREQUENCY	50Hz
4	NO. OF PHASES	3
5	RATED INSULATION LEVELS	
	i) FULL WAVE IMPULSE WITHSTAND VOLTAGE (1.2/50microsec.)	±1425kVp
	ii) SWITCHING IMPULSE WITHSTAND VOLTAGE (250/2500microsec.)	+1050kVp
	iii) ONE MINUTE POWER FREQUENCY WITHSTAND VOLTAGE (rms)	630kV (rms)
6	CORONA EXTINCTION VOLTAGE (MIN)	320kV (rms)
7	MAX. RADIO INTERFERENCE VOLTAGE FOR FREQUENCY BETWEEN 0.5MHz & 2MHz AT 266kV rms	1000 microV
8	MIN. CREEPAGE DISTANCE	25 mm/kV (10500 mm)
9	MIN. CLEARANCE	
	i) PHASE TO PHASE	4000MM
	ii) PHASE TO EARTH	3500MM
	iii) SECTIONAL CLEARANCE	6500MM
10	RATED SHORT CIRCUIT CURRENT FOR 1SEC DURATION	6.3kA*
11	SYSTEM NEUTRAL EARTHING	EFFECTIVELY EARTHED
12	SUB CONDUCTOR SPACING	450MM

LEGEND & BILL OF QUANTITY FOR STAGE-II

S.N.	ITEM DESCRIPTION	LEGEND	QTY (NOS)
1.	400kV, 3150 A, 63kA FOR 1 SEC. SF6, CIRCUIT BREAKER (3-PH)		04
2.	400kV, 3150 A, 63kA FOR 1 SEC. HCB DISCONNECTOR WITH 1 ES. (3-PH), MECHANICALLY GANGED		12
3.	400kV BUS POST INSULATOR (EXCL. ISOLATOR AND WT)		30
4.	336kV LIGHTNING ARRESTER (1-PH)		06
5.	400kV CAPACITIVE VOLTAGE TRANSFORMER (1-PH)		06
6.	400kV CURRENT TRANSFORMER (1-PH)		24
7.	EXISTING FENCE		NA
8.	EXISTING ROAD		NA

CONDUCTOR & STRINGING DETAILS :-

SL.NO.	DESCRIPTION	CONDUCTOR DETAIL	CONNECTION HEIGHT (ABOVE PLINTH LEVEL)
1.	EQUIPMENT INTERCONNECTION	4.0" IPS (EH) AL. TUBE/	8mtr.
2.	JACK BUS ON GT/ST SIDE	TWIN ACSR BERSIMIS CONDUCTOR	23 mtr. FROM GT YARD FGL
3.	JACK BUS LINE SIDE ((RGH-KOT)	TWIN ACSR BERSIMIS CONDUCTOR	16/23 mtr.
4.	LINE SIDE DEAD-END STRINGING	*QUAD ACSR MOOSE CONDUCTOR	23 mtr.
5.	EARTHWIRE	7/3.66mm SHIELD WIRE	31.5 mtr
6.	DROPPER ON CVT, LA	TWIN ACSR BERSIMIS CONDUCTOR	-
7.	MAIN BUS-I/II	QUAD ACSR BERSIMIS CONDUCTOR	16 mtr.

NOTES:

1. ALL DIMENSIONS ARE IN MM.
2. ALL STRUCTURE/CONDUCTOR HEIGHTS ARE ABOVE PLINTH LEVEL. PLINTH LEVEL IS 300 MM ABOVE F.G.L.
3. TYPE OF GANTRY STRUCTURES SHALL BE AS PER APPROVED STRUCTURAL LAYOUT DRAWING.
4. SWITCHYARD LIGHTNING PROTECTION SHALL BE ACHIEVED THROUGH SHIELD WIRES AS PER APPROVED DSLP.
5. SA PRESSURE RELIEF VALVE SHALL NOT BE TOWARDS TRANSFORMER SIDE / ANY EQUIPMENT KEPT NEAR LIGHTING ARRESTER AND BHEL SHALL ENSURE THE SAME DURING ERECTION AT SITE.
6. DEAD END TOWERS LOCATION FOR THE CONNECTION TO STAGE-II ALONG WITH TRANSMISSION LINE TOWERS SHALL BE FINALIZED AFTER ROUTE SURVEY & NTPC APPROVAL.
7. PHASE TO PHASE CLEARANCE SHALL BE KEPT 7M TYPICAL & GANTRY WIDTH OF 27M.
7. \* AS PER NTPC, THE EQUIPMENT IN STAGE-I EXTENSION SHALL BE SUITABLE FOR SC RATING OF 63kA FOR 1 SEC

REFERENCE DRAWINGS:  
 1. BHEL-400 kV Switchyard Single Line Diagram-9587-001-230-PVE-P-0002, REV.01  
 2. STAGE-I LAYOUT FOR 400kV SWITCHYARD-9546-572-PVE-F-0005, REV.06

CUSTOMER DRAWING NO. NTPC LIMITED  
 2 X 800 MW NTPC LARA STPS STAGE-II EPC

भारत हेवी इलेक्ट्रिकल्स लिमिटेड  
 BHARAT HEAVY ELECTRICALS LTD.  
 TRANSMISSION BUSINESS GROUP

DEPT. SCALE: BHEL DRAWING NO. TB-423-316-003  
 SHEET 03 OF 03 REV. 00

COPY RIGHT AND CONFIDENTIAL  
 The information on this document is the property of BHARAT HEAVY ELECTRICALS LIMITED  
 It must not be used directly or indirectly in any way detrimental to the interest of the company.  
 COMPUTER FILE NAME: PC-00-115-101-003-...

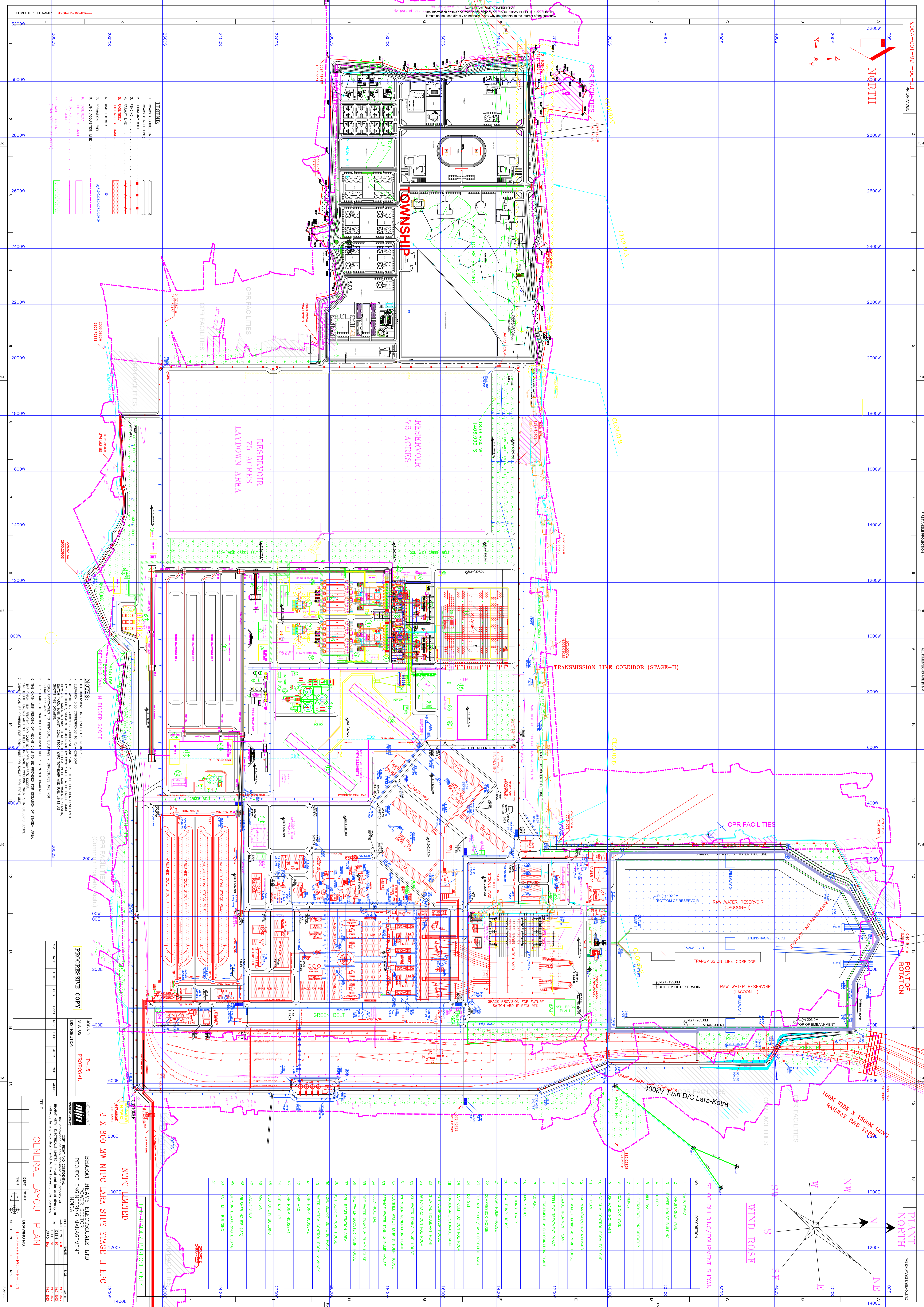
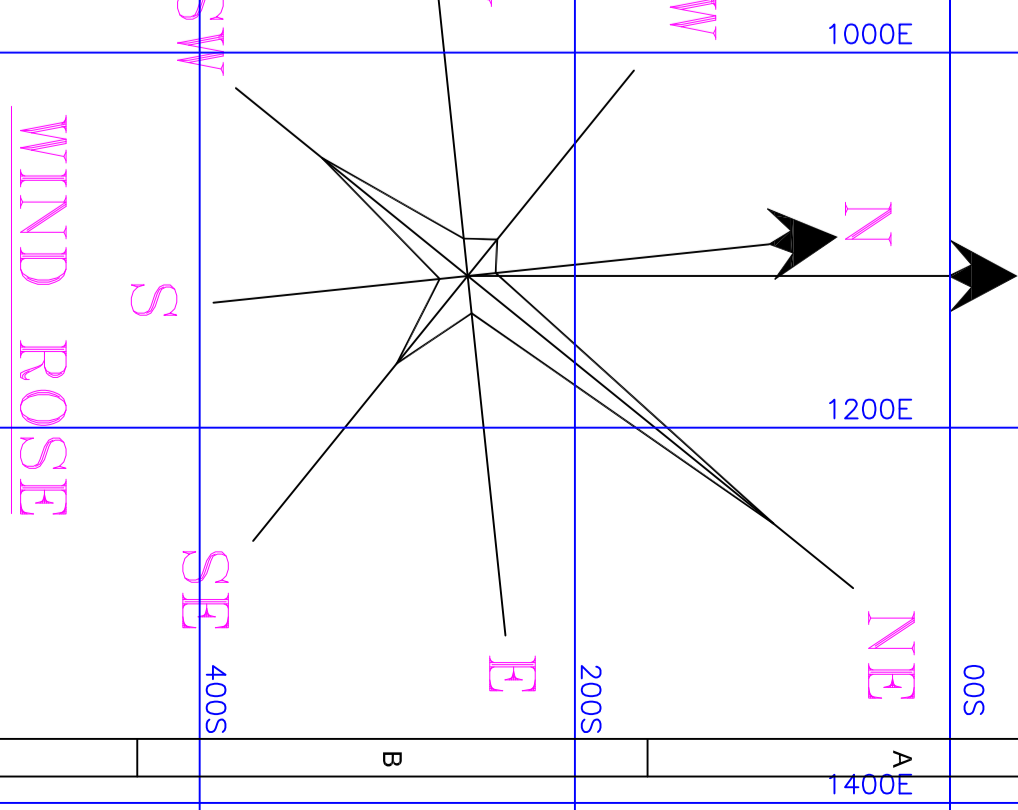
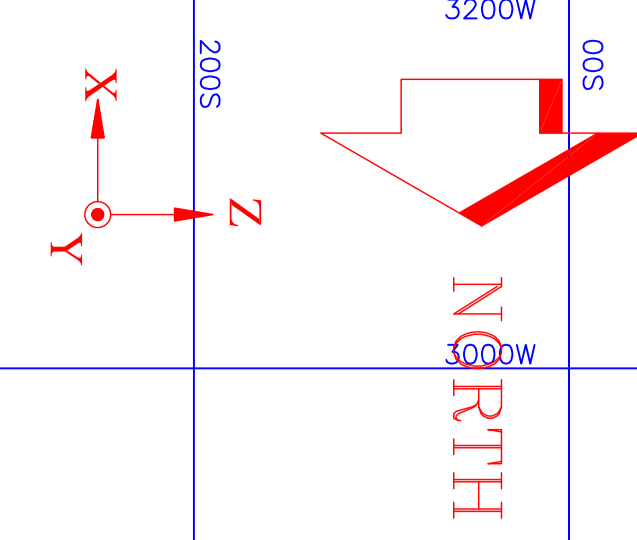

- LEGEND:**
1. Roads (Double Line)
  2. Boundary Wall
  3. Retaining Wall
  4. Retaining Wall (with Slope)
  5. Retaining Wall (with Slope and Drain)
  6. Retaining Wall (with Slope and Drain and Wall)
  7. Retaining Wall (with Slope and Drain and Wall and Drain)
  8. Retaining Wall (with Slope and Drain and Wall and Drain and Wall)
  9. Retaining Wall (with Slope and Drain and Wall and Drain and Wall and Drain)
  10. Retaining Wall (with Slope and Drain and Wall and Drain and Wall and Drain and Wall)
  11. Retaining Wall (with Slope and Drain and Wall and Drain and Wall and Drain and Wall and Drain)

- NOTES:**
1. ALL DIMENSIONS AND LEVELS ARE IN METERS.
  2. ELEVATION AND DIMENSIONS TO BE USED AS SHOWN UNLESS OTHERWISE SPECIFIED.
  3. THE OWNER HAS TO PROVIDE ALL NECESSARY SERVICES AND UTILITIES TO THE SITE.
  4. THE OWNER HAS TO PROVIDE ALL NECESSARY SERVICES AND UTILITIES TO THE SITE.
  5. THE OWNER HAS TO PROVIDE ALL NECESSARY SERVICES AND UTILITIES TO THE SITE.
  6. THE OWNER HAS TO PROVIDE ALL NECESSARY SERVICES AND UTILITIES TO THE SITE.
  7. THE OWNER HAS TO PROVIDE ALL NECESSARY SERVICES AND UTILITIES TO THE SITE.
  8. THE OWNER HAS TO PROVIDE ALL NECESSARY SERVICES AND UTILITIES TO THE SITE.
  9. THE OWNER HAS TO PROVIDE ALL NECESSARY SERVICES AND UTILITIES TO THE SITE.
  10. THE OWNER HAS TO PROVIDE ALL NECESSARY SERVICES AND UTILITIES TO THE SITE.
  11. THE OWNER HAS TO PROVIDE ALL NECESSARY SERVICES AND UTILITIES TO THE SITE.

**PROGRESSIVE COPY**

REV.	DATE	BY	CHKD	APPD	REV.	DATE	BY	CHKD	APPD

**GENERAL LAYOUT PLAN**

NO.	DESCRIPTION
1	SWITCHYARD
2	TRANSFORMER YARD
3	POWER HOUSE BUILDING
4	BOILER
5	WATER TOWER
6	ELECTROSTATIC PRECIPITATOR
7	CHIMNEY
8	SOIL STOCK YARD
9	ASH HANDLING PLANT
10	MCC CUM CONTROL ROOM FOR CHP
11	FT PLANT
12	6X4 PLANT(RO/CONVENTIONAL)
13	D/W WATER TANKS & PUMP HOUSE
14	SEWER TREATMENT PLANT
15	EFFLUENT TREATMENT PLANT
16	WATER TREATMENT PLANT
17	WATER TREATMENT PLANT
18	WATER TREATMENT PLANT
19	WATER TREATMENT PLANT
20	WATER TREATMENT PLANT
21	WATER TREATMENT PLANT
22	WATER TREATMENT PLANT
23	WATER TREATMENT PLANT
24	WATER TREATMENT PLANT
25	WATER TREATMENT PLANT
26	WATER TREATMENT PLANT
27	WATER TREATMENT PLANT
28	WATER TREATMENT PLANT
29	WATER TREATMENT PLANT
30	WATER TREATMENT PLANT
31	WATER TREATMENT PLANT
32	WATER TREATMENT PLANT
33	WATER TREATMENT PLANT
34	WATER TREATMENT PLANT
35	WATER TREATMENT PLANT
36	WATER TREATMENT PLANT
37	WATER TREATMENT PLANT
38	WATER TREATMENT PLANT
39	WATER TREATMENT PLANT
40	WATER TREATMENT PLANT
41	WATER TREATMENT PLANT
42	WATER TREATMENT PLANT
43	WATER TREATMENT PLANT
44	WATER TREATMENT PLANT
45	WATER TREATMENT PLANT
46	WATER TREATMENT PLANT
47	WATER TREATMENT PLANT
48	WATER TREATMENT PLANT
49	WATER TREATMENT PLANT
50	WATER TREATMENT PLANT
51	WATER TREATMENT PLANT

**GENERAL LAYOUT PLAN**

NO.	DESCRIPTION
1	SWITCHYARD
2	TRANSFORMER YARD
3	POWER HOUSE BUILDING
4	BOILER
5	WATER TOWER
6	ELECTROSTATIC PRECIPITATOR
7	CHIMNEY
8	SOIL STOCK YARD
9	ASH HANDLING PLANT
10	MCC CUM CONTROL ROOM FOR CHP
11	FT PLANT
12	6X4 PLANT(RO/CONVENTIONAL)
13	D/W WATER TANKS & PUMP HOUSE
14	SEWER TREATMENT PLANT
15	EFFLUENT TREATMENT PLANT
16	WATER TREATMENT PLANT
17	WATER TREATMENT PLANT
18	WATER TREATMENT PLANT
19	WATER TREATMENT PLANT
20	WATER TREATMENT PLANT
21	WATER TREATMENT PLANT
22	WATER TREATMENT PLANT
23	WATER TREATMENT PLANT
24	WATER TREATMENT PLANT
25	WATER TREATMENT PLANT
26	WATER TREATMENT PLANT
27	WATER TREATMENT PLANT
28	WATER TREATMENT PLANT
29	WATER TREATMENT PLANT
30	WATER TREATMENT PLANT
31	WATER TREATMENT PLANT
32	WATER TREATMENT PLANT
33	WATER TREATMENT PLANT
34	WATER TREATMENT PLANT
35	WATER TREATMENT PLANT
36	WATER TREATMENT PLANT
37	WATER TREATMENT PLANT
38	WATER TREATMENT PLANT
39	WATER TREATMENT PLANT
40	WATER TREATMENT PLANT
41	WATER TREATMENT PLANT
42	WATER TREATMENT PLANT
43	WATER TREATMENT PLANT
44	WATER TREATMENT PLANT
45	WATER TREATMENT PLANT
46	WATER TREATMENT PLANT
47	WATER TREATMENT PLANT
48	WATER TREATMENT PLANT
49	WATER TREATMENT PLANT
50	WATER TREATMENT PLANT
51	WATER TREATMENT PLANT

**GENERAL LAYOUT PLAN**

NO.	DESCRIPTION
1	SWITCHYARD
2	TRANSFORMER YARD
3	POWER HOUSE BUILDING
4	BOILER
5	WATER TOWER
6	ELECTROSTATIC PRECIPITATOR
7	CHIMNEY
8	SOIL STOCK YARD
9	ASH HANDLING PLANT
10	MCC CUM CONTROL ROOM FOR CHP
11	FT PLANT
12	6X4 PLANT(RO/CONVENTIONAL)
13	D/W WATER TANKS & PUMP HOUSE
14	SEWER TREATMENT PLANT
15	EFFLUENT TREATMENT PLANT
16	WATER TREATMENT PLANT
17	WATER TREATMENT PLANT
18	WATER TREATMENT PLANT
19	WATER TREATMENT PLANT
20	WATER TREATMENT PLANT
21	WATER TREATMENT PLANT
22	WATER TREATMENT PLANT
23	WATER TREATMENT PLANT
24	WATER TREATMENT PLANT
25	WATER TREATMENT PLANT
26	WATER TREATMENT PLANT
27	WATER TREATMENT PLANT
28	WATER TREATMENT PLANT
29	WATER TREATMENT PLANT
30	WATER TREATMENT PLANT
31	WATER TREATMENT PLANT
32	WATER TREATMENT PLANT
33	WATER TREATMENT PLANT
34	WATER TREATMENT PLANT
35	WATER TREATMENT PLANT
36	WATER TREATMENT PLANT
37	WATER TREATMENT PLANT
38	WATER TREATMENT PLANT
39	WATER TREATMENT PLANT
40	WATER TREATMENT PLANT
41	WATER TREATMENT PLANT
42	WATER TREATMENT PLANT
43	WATER TREATMENT PLANT
44	WATER TREATMENT PLANT
45	WATER TREATMENT PLANT
46	WATER TREATMENT PLANT
47	WATER TREATMENT PLANT
48	WATER TREATMENT PLANT
49	WATER TREATMENT PLANT
50	WATER TREATMENT PLANT
51	WATER TREATMENT PLANT

**FORMAT OF NO DEVIATION CERTIFICATE  
(To be submitted in the bidder's letter head)**

REF: .....

Dated.....

**BHARAT HEAVY ELECTRICALS LIMITED,  
TRANSMISSION BUSINESS GROUP,  
Plot No- 25, Sector- 16A, Noida,  
Distt. Gautambudh Nagar, UP-201301**

**SUBJECT: Tender for "PRELIMINARY, DETAILED & CHECK ROUTE SURVEY AND GEOTECHNICAL INVESTIGATION ALONG WITH DESIGN AND ENGINEERING WORKS FOR 400KV TRANSMISSION LINE AT 2X800 MW NTPC LARA STAGE-II."**

**TENDER NO.: - TBSM/LARA/SURVEY/TENDER/24-25**

**Date: - 09.05.2024**

Dear Sir,

With reference to above, this is to confirm that as per tender conditions, we have visited subject site before submission of our offer and noted the job content & site conditions etc.

We also confirm that we have not changed / modified the tender documents as appeared in the website and in case of observance at any stage, it shall be treated as null and void. We hereby confirm that we have not taken any deviation from tender clauses together with other references as enumerated in the above referred NIT and we hereby convey our unqualified acceptance to all terms and conditions as stipulated in the tender and NIT. In the event of observance of any deviation in any part of our offer at a later date whether implicit or explicit, the deviations shall stand null & void.

We confirm to have submitted offer strictly in accordance with tender instructions.

Thanking you,

Yours faithfully,

(Signature, date & seal of authorized representative of the bidder)

## DECLARATION FOR RELATION IN BHEL

(To be typed and submitted in the Letter Head of the Company/Firm of Bidder failing which the offer of Bidder is liable to be summarily rejected)

**Ref:**

**Date.....**

**To,  
AGM/TBSM  
BHARAT HEAVY ELECTRICALS LIMITED,  
TRANSMISSION BUSINESS GROUP,  
PLOT NO.-25, SECTOR-16A,  
NOIDA - 201301 (U.P.)**

Dear Sir,

Sub: Declaration for relation in BHEL

Ref: 1) NIT/Tender Specification No.: **TBSM/LARA/SURVEY/TENDER/24-25, Date: - 09.05.2024**

I/We hereby submit the following information pertaining to relation/relatives of Proprietor/ Partner(s)/Director(s) employed in BHEL

**Tick (√) any one as applicable:**

1. The Proprietor, Partner(s), Director(s) of our Company/Firm DO NOT have any relation or relatives employed in BHEL

OR

2. The Proprietor, Partner(s), or Director(s) of our Company / Firm HAVE relation / relatives employed in BHEL and their particulars are as below:

a)

b)

Signature of the Authorized Signatory

**Note:**

- 1) Attach separate sheet, if necessary.
- 2) If BHEL Management comes to know at a later date that the information furnished by the Bidder is false, BHEL reserves the right to take suitable against the Bidder/ Contractor.

**DECLARATION BY AUTHORISED SIGNATORY OF BIDDER**  
(To be typed and submitted in the Letter Head of the Company/Firm of Bidder)

To,

AGM/TBSM Transmission Business Group,  
Bharat Heavy Electricals Limited, 5th Floor, BHEL SADAN, Plot No. 25, Sector-16A, Noida,  
U.P.-201301

Dear Sir,

**Sub : Declaration by Authorized Signatory regarding Authenticity of submitted documents.**

Ref : 1) NIT/Tender Specification No: TBSM/LARA/SURVEY/TENDER/24-25 DTD. 09-05-24

2) All other pertinent issues till date

I/We, hereby certify that all the documents submitted by us in support of possession of <Qualifying Requirements= are true copies of the original and are fully compliant required for qualifying / applying in the bid and shall produce the original of same as and when required by Bharat Heavy Electricals Limited.

I / We hereby further confirm that no tampering is done with documents submitted in support of our qualification as bidder. I / We understand that at any stage (during bidding process or while executing the awarded works) if it is found that fake / false / forged bid qualifying /supporting documents / certificates were submitted, it would lead to summarily rejection of our bid / termination of contract. BHEL shall be at liberty to initiate other appropriate actions as per the terms of the Bid / Contract and other extant policies of Bharat Heavy Electricals Limited.

Yours faithfully,

(Signature, Date & Seal  
of Authorized Signatory  
of the Bidder)

Date:

Place:

