

**BHARAT HEAVY ELECTRICALS LIMITED
TRANSMISSION BUSINESS GROUP
SUBCONTRACTS MANAGEMENT
PLOT NO. 25, SECTOR 16A, NOIDA,
DISTT. – GAUTAM BUDDH NAGAR (U.P.) - 201301**



TENDER DOCUMENTS

FOR

**SOIL INVESTIGATION & TOPOGRAPHY SURVEY WORK AT
765/400/220KV AT VATAMAN (NEW) & EXTENSION OF 765 KV
S/S AT HALVAD IN GUJARAT.**

CUSTOMER

M/S POWERGRID CORPORATION OF INDIA LTD.

TENDER SPEC. NO.: TBSM/VATAMAN & HALVAD/SI/TENDER/23-24

DATE: 02.04.2024

TRANSMISSION BUSINESS GROUP
SUBCONTRACTS MANAGEMENT
INDEX

Sl. No.	Description	No. of Pages
1.0	Notice Inviting Tender	09
2.0	Pre-Qualifying Requirements	02
3.0	Project Information/ BHEL's Contacts	01
4.0	Health, Safety & Environment specification (Doc. No.: - TBG/HSE/NIT-01, Rev-02 Date 31.01.2024)	19
5.0	Terms and Conditions of Contract	20
6.0	Annexure A of Clause No. N of Annexure to conditions of contract for Civil Works - "BHEL Conciliation Scheme"	11
7.0	Bill of Quantity Cum price schedule (Annexure-I)	01
8.0	Price Bid Format: - To be filled by the Bidder Online through https://eprocurebhel.co.in	01
9.0	Technical Specification	30
10.0	No Deviation Certificate	01
11.0	Declaration for relation in BHEL	01
12.0	E payment Format	01



BHARAT HEAVY ELECTRICALS LIMITED

TRANSMISSION BUSINESS GROUP

SECTOR-16A, NOIDA -201301

e-mail: dipak.mandal@bhel.in

NOTICE INVITING TENDER

REF.: TBSM/VATAMAN & HALVAD/SI/TENDER/23-24

DATE: 02.04.2024

SUB: TENDER FOR "SOIL INVESTIGATION & TOPOGRAPHY SURVEY WORK AT 765/400/220KV AT VATAMAN (NEW) & EXTENSION OF 765 KV S/S AT HALVAD IN GUJARAT".

Dear Sirs,

1. Sealed tenders are invited for the following:

NAME OF WORK	TIME OF COMPLETION	EARNEST MONEY DEPOSIT	TENDER SUBMISSION DATE AND TIME	TENDER OPENING DATE & TIME
Soil Investigation & Topography Survey work at 765/400/220kV at Vataman (New) & Extension of 765 kV S/s at Halvad in Gujarat.	30 days from the date of LOI	Nil	12.04.2024 14.30 hrs.	12.04.2024 15.30 hrs. (Technical bid only)

2. Bidder **has** to submit offer directly through E-PROCUREMENT MODE. Bidder may visit <https://eprocurebhel.co.in>

Procedure for Submission of Tenders through e-tendering: The tender is also floated online through our E-Procurement Site <https://eprocurebhel.co.in>. The bidder may respond by submitting their offer online in our e-Procurement platform at <https://eprocurebhel.co.in>

Offers are invited in two-parts only.

Documents Comprising the e-Tender

The tender shall be submitted online EXCEPT EMD (which shall be submitted in physical form (as described in NIT cl. No.1) above as mentioned below:

a) Technical Bid (Un priced Tender)

All Technical details (e.g. Eligibility Criteria requested (as mentioned below)) should be attached in e-tendering module, failing which the tender stands invalid & may be REJECTED. Bidders shall furnish the following information along with technical tender (preferably in pdf format):

- Earnest money Deposit (EMD) furnished in accordance with NIT Clause 4.0
- Technical Bid (without indicating any prices).

b) Price Bid:

- Prices are to be quoted in the attached Price Bid format online on e-tender portal.
- The price should be quoted for the accounting unit indicated in the e-tender document.
- Note: It is the responsibility of tenderer to go through the Tender document to ensure furnishing all required documents in addition to above, if any. Any deviation would result in REJECTION of tender and would not be considered at a later stage at any cost by BHEL.
- A person signing (manually or digitally) the tender form or any documents forming part of the contract on behalf of another shall be deemed to warrantee that he has authority to bind such other persons and if, on enquiry, it appears that the persons so signing had no authority to do so, the purchaser may, without prejudice to other

civil and criminal remedies, cancel the contract and hold the signatory liable for all cost and damages.

- v) A tender, which does not fulfil any of the above requirements and/or gives evasive information/reply against any such requirement, shall be liable to be ignored and rejected.
- c) Uploading of the price bid in prequalification bid or technical bid may RESULT IN REJECTION of the tender.
- d) Tenders shall be uploaded with all relevant PDF/zip format. The relevant tender documents should be uploaded by an authorized person having Class 3- SHA2- 2048 BIT- SIGNING & ENCRYPTION digital signature certificate (DSC).

TENDER SPEC. NO.: TBSM/VATAMAN & HALVAD/SI/TENDER/23-24	DATE: 02.04.2024
TO,	
Dipak Kumar Mandal	
AGM (TBSM)	
BHARAT HEAVY ELECTRICALS LIMITED,	
TRANSMISSION BUSINESS GROUP,	
Plot no.: - 25, Sector- 16A, Noida, Distt. – Gautam Buddh Nagar, UP-201301	
TELEPHONE: 0120-6748134, 99111 63182	
E-mail: dipak.mandal@bhel.in	

3. **Bidders may please note that no other mode of bid submission shall be considered for evaluation apart from Clause no. 02 mentioned above.**
4. The prospective bidders who have downloaded the tender documents from our website are requested to send their acknowledgement and willingness to participate in the tender to the undersigned, through fax or email.
5. Offers should be strictly in accordance with the Tender Specifications and General Instructions to Tenderer enclosed herewith.
6. “BHEL shall be resorting to Reverse Auction (RA) (Guidelines as available on www.bhel.com) for this tender. RA shall be conducted among all the techno-commercially qualified bidders.
- Price bids of all techno-commercially qualified bidders shall be opened and same shall be considered for RA. In case any bidder(s) do(es) not participate in online Reverse Auction, their price bid along with applicable loading, if any, shall be considered for ranking.”
7. The contractor shall give his explicit confirmation without any deviations to the HSE (Health, Safety and Environment) requirements as per enclosed specification No. TBSM/HSE/NIT-01, Rev-02 Date 31.01.2024. Contactors are also required to furnish details as per Annexure (HSE) to NIT along with their offer. Offers received without compliance & data about HSE requirements are liable to be rejected.
8. All documents submitted with the offer shall be signed and stamped in each page by authorized representative of the bidder.
9. Clarifications, if any, can be obtained from the undersigned but such requests should be submitted well before the due date for submission of tenders. Due date for submission and opening of tenders will not be extended on such grounds.
10. Drawings & FQP enclosed with the NIT (if provided) are for tender purpose only. Drawings & FQP may get change during execution stage and work to be carried as per latest RFC drawings & Field Quality Plan (FQP).
11. Construction/ RFC drawing/ Fronts shall be furnished progressively as per project requirement and no claim towards idling charges/ project overheads etc. borne by the contractor on account of non-availability of drawings/ fronts shall be entertained.

12. Completion period of the work has been envisaged under best possible conditions. Any changes/ deviation during execution shall be dealt as per relevant clauses mentioned in Terms & conditions of contract.
13. *"In case this tender is awarded to first time contractor*, then the bidder shall be eligible to qualify for the next tender of similar work# of BHEL, TBG; only after successful executing of 50% (fifty percent) of this work prior to the date of next tender (in which bidder desires to quote) and on satisfactory performance feedback by BHEL site Incharge."*

** First time contractor: The bidders who have not successfully executed more than 50% (fifty percent) of awarded similar work by BHEL (TBG/ ISG/Power Sector/Any BHEL Unit) in last 5 years from date of NIT.*

The bidders who have taken any order from BHEL under 1st time category, and desires to further participate in BHEL tenders, needs to submit a certificate/ undertaking mentioning the reason of not executing 50% of awarded work, hence the criteria under 1st time bidder shall not be applicable to them. The certificate/ undertaking shall be duly certified by Site In charge of BHEL

Similar work: Similar to nature of work of the tender under consideration.

14. The offers of the bidders who are under suspension as also the offers of the bidders, who engage the services of the banned firms, shall be rejected. The list of banned firms is available on BHEL web site www.bhel.com.
15. Integrity commitment, performance of the contract and punitive action thereof:

17.1. Commitment by BHEL:

BHEL commits to take all measures necessary to prevent corruption in connection with the tender process and execution of the contract. BHEL will during the tender process treat all Bidder(s) in a transparent and fair manner, and with equity.

17.2. Commitment by Bidder/ Supplier/ Contractor:

17.2.1. The bidder/ supplier/ contractor commits to take all measures to prevent corruption and will not directly or indirectly influence any decision or benefit which he is not legally entitled to nor will act or omit in any manner which tantamount to an offence punishable under any provision of the Indian Penal Code, 1860 or any other law in force in India.

17.2.2. The bidder/ supplier/ contractor will, when presenting his bid, disclose any and all payments he has made, and is committed to or intends to make to agents, brokers or any other intermediaries in connection with the award of the contract and shall adhere to relevant guidelines issued from time to time by Govt. of India/ BHEL.

17.2.3. The bidder/ supplier/ contractor will perform/ execute the contract as per the contract terms & conditions and will not default without any reasonable cause, which causes loss of business/ money/ reputation, to BHEL.

If any bidder/ supplier/ contractor during pre-tendering/ tendering/ post tendering/ award/ execution/ post-execution stage indulges in mal-practices, cheating, bribery, fraud or and other misconduct or formation of cartel so as to influence the bidding process or influence the price or acts or omits in any manner which tantamount to an offence punishable under any provision of the Indian Penal Code, 1860 or any other law in force in India, then, action may be taken against such bidder/ supplier/ contractor as per extant guidelines of the company available on [www. bhel.com](http://www.bhel.com) and/or under applicable legal provisions".

16. Also, offer of the bidders who are suspended (under hold/ delist) for business dealings by BHEL, TBG shall not be considered. Please note that lifting/ restoration of suspension (Ban/Hold/ De-list) of business dealing is not automatic after expiry of specified suspension period. Hence, vendor shall be considered as suspended for business till suspension is lifted by BHEL in writing on specific request of the vendor as per extant guidelines.

17. BHEL Fraud Prevention Policy, "The Bidder along with its associate/ collaborators/ sub-contractors/ sub-vendors/ consultants/ service providers shall strictly adhere to BHEL Fraud Prevention Policy displayed on BHEL website <http://www.bhel.com> and shall immediately bring to the notice of BHEL Management about any fraud or suspected fraud as soon as it comes to their notice."
18. Offers will be scrutinized based on the qualifying requirements and only those who are technically and financially capable to execute the Job and who fulfil the Pre-Qualifying Requirements (PQR) are eligible to quote against the above NIT. However, final acceptance of the bidder/ offer shall be subject to acceptance of our customer.
19. The evaluation currency for this tender shall be INR.
20. In the course of evaluation, if more than one bidder happens to occupy L-1 status, effective L-1 will be decided by soliciting discounts from the respective L-1 bidders.

In case more than one bidder happens to occupy the L-1 status even after soliciting discounts, the L-1 bidder shall be decided by toss/ draw of lots, in the presence of the respective L-1 bidder(s) or their representative(s).

Ranking will be done accordingly. BHEL's decision in such situations shall be final and binding.
21. Technical Bid will be opened in the office of undersigned. If required, technical discussions will be held with only those bidders who have taken any deviations. Bidders representative may be present during technical bid opening for technical discussion, if required. The price bids will be opened subsequently, after Technical Bids of all the bidders have been evaluated and frozen. Bidders should quote their most competitive rates as there will not be any price negotiation. However, if felt necessary by BHEL, price negotiation will be held with lowest bidder (L-1) only. **IT WOULD BE PREFERRED THAT YOUR OFFER IS WITHOUT ANY DEVIATION w.r.t. TENDER SPECIFICATIONS AND THE SAME MAY BE CLEARLY MENTIONED ON THE COVERING LETTER ACCOMPANYING THE TECHNICAL BID.** Offers with deviations are likely to be rejected. However, if the bidder insists on any technical or commercial deviations, from the specification and/or tender conditions, the price implication if any, of withdrawing the deviations must be submitted along with the price bid in a separate sealed envelope superscribed "Price Implication for withdrawal of deviations".
22. In case any adverse information is received concerning performance, capability or conduct of the bidder after issue of tender enquiry, BHEL reserves the right to reject the offer at any stage as deemed fit.
23. Any materials (if required) for this work have to be procured from Customer approved sources only. It will be the bidder's responsibility to get the approval of materials and vendors for materials.
24. The purchase preference for central P.S.U.s shall be given as per the prevailing Government policy.
25. Work schedule and the deployment of manpower and T&P resources committed by the contractor in their offer, to match the scheduled completion, shall be submitted by contractor and mutually agreed with site In-charge immediately after the award of work. Further, the contractor shall mobilise at site within two weeks of award of work.
26. In case an offer is not being submitted by the prospective bidders against this tender, they may send their "regret" letter to this office, for information.
27. Details of qualifying work(s) executed by the bidder will be forwarded to the principal employer for verification of the work with respect to completion, commencement & completion date and value of the work executed. Performance feedback of the bidder will also be sought from the principal employer.
28. The bidder representative may be called for discussion with the committee. His originals may be verified by the committee. In addition to above their organisation chart and detail list of manpower, tools & plants and technical capability will be discussed and ascertained by the committee.

29. Conflict of Interest among bidders/Agents: -

"A bidder shall not have conflict of interest with other bidders. Such conflict of interest can lead to anti-competitive practices to the detriment of Procuring Entity's interests. **The bidder found to have a conflict of interest shall be disqualified.** A bidder may be considered to have a conflict of interest with one or more parties in this bidding process, if:

- a) they have controlling partner (s) in common; **or**
- b) they receive or have received any direct or indirect subsidy/ financial stake from any of them; **or**
- c) they have the same legal representative/agent for purposes of this bid; **or**
- d) they have relationship with each other, directly or through common third parties, that puts them in a position to have access to information about or influence on the bid of another Bidder; **or**
- e) Bidder participates in more than one bid in this bidding process. Participation by a Bidder in more than one Bid will result in the disqualification of all bids in which the parties are involved. However, this does not limit the inclusion of the components/ sub-assembly/ Assemblies from one bidding manufacturer in more than one bid; **or**
- f) In cases of agents quoting in offshore procurements, on behalf of their principal manufacturers, one agent cannot represent two manufacturers or quote on their behalf in a particular tender enquiry. One manufacturer can also authorise only one agent/dealer. There can be only one bid from the following:
 1. The principal manufacturer directly or through one Indian agent on his behalf; and
 2. Indian/foreign agent on behalf of only one principal;**or**
- g) A Bidder or any of its affiliates participated as a consultant in the preparation of the design or technical specifications of the contract that is the subject of the Bid; **or**
- h) In case of it holding company having more than one independently manufacturing units, or more than one unit having common business ownership/management, only one unit should quote. Similar restrictions would apply to closely related sister companies. Bidders must proactively declare such sister/ common business/ management units in same/ similar line of business. "

Thanking you,

Yours faithfully,
For and on behalf of BHEL,

(Dipak Kumar Mandal)
AGM /TBSM

TO BE FILLED BY TENDERER OVER THEIR LETTERHEAD

ANNEXURE - X

REF.: TBSM/VATAMAN & HALVAD/SI/TENDER/23-24

DATE: 02.04.2024

SUB: TENDER FOR "SOIL INVESTIGATION & TOPOGRAPHY SURVEY WORK AT 765/400/220KV AT VATAMAN (NEW) & EXTENSION OF 765 KV S/S AT HALVAD IN GUJARAT".

It is certified that General Instructions and Information for tenderer have been read/ complied/ agreed to and each page of tender offer has been initialled and stamped.

Also It is being declares that we (.....Bidder Name) will not enter into any illegal or undisclosed agreement or understanding, whether formal or informal with other Bidder(s). This applies in particular to prices, specifications, certifications, subsidiary contracts, submission or non-submission of bids or any other actions to restrict competitiveness or to introduce cartelization in the bidding process.

In case, the Bidder is found having indulged in above activities, suitable action shall be taken by BHEL as per extant policies/ guidelines

(Signature of Tenderer)

Name and Designation of Authorised person (s)
Signing the tender on behalf of the tenderer

ANNEXURE – Y

REF.: TBSM/VATAMAN & HALVAD/SI/TENDER/23-24

DATE: 02.04.2024

SUB: TENDER FOR “SOIL INVESTIGATION & TOPOGRAPHY SURVEY WORK AT 765/400/220KV AT VATAMAN (NEW) & EXTENSION OF 765 KV S/S AT HALVAD IN GUJARAT”.

Subject: Authorization of representative who will participate in the Online Reverse Auction Process:

1	NAME & DESIGNATION OF OFFICIAL	
2	POSTAL ADDRESS (COMPLETE)	
3	TELEPHONE NOS. (LAND LINE & MOBILE BOTH)	
4	FAX NO.	
5	E-MAIL ADDRESS	
6	NAME OF PLACE / STATE / COUNTRY, WHEREFROM S/HE WILL PARTICIPATE IN THE REVERSE AUCTION	

BHARAT HEAVY ELECTRICALS LIMITED
TRANSMISSION BUSINESS GROUP, NOIDA
PRE-QUALIFYING REQUIREMENTS

Tender Ref. No.: TBSM/VATAMAN & HALVAD/SI/TENDER/23-24,

DATE: 02.04.2024

SUB: TENDER FOR “SOIL INVESTIGATION & TOPOGRAPHY SURVEY WORK AT 765/400/220KV AT VATAMAN (NEW) & EXTENSION OF 765 KV S/S AT HALVAD IN GUJARAT”.

Tenders (Under two-part bid system) are invited from competent contractors for subject works. Only those who are technically and financially capable to execute the Job and who fulfil the Pre-Qualifying Requirements [PQR] given under are eligible to quote against the above NIT. Tenderers should submit their offer as per the procedure specified in tender documents. The PQR of contractor for tender submission shall be as under:

Sl. No.	Criteria	Description
A	Turn Over	<p>Bidders should have a minimum average annual turnover (Annual Gross Revenue from operations/ Gross operating income as incorporated in the profit & loss account excluding Other Income) of Rs. 7,92,157/- for best three fin. Years i.e. 36 months out of last five financial years (2018-19, 2019-20, 2020-21, 2021-22 & 2022-23) and should submit audited balance sheet and Profit & Loss Account Sheet of these years.</p> <p>In case audited financial statements have not been submitted for all the years as indicated above, then the applicable audited statements submitted by the bidders against the requisite three years, will be averaged for three years i.e. total divided by three.</p> <p>The audited financial statements must be signed by the owner and the auditor. Auditors seal, Name, Membership No., Firm Registration No. & firm name (if applicable), UDIN and the capacity in which he is signing (Proprietor/Partner), must be mentioned on the Profit & Loss A/c and Balance Sheet.</p> <p>In case audited balance sheet is not available due to turnover being less than statutory requirement of audit, bidder should furnish self-certified copies of Balance Sheet, Profit & Loss account along with income tax returns and form 26AS of these years.</p>
B	Profit	Vendor should have earned profit in at least one year during last Three financial years out of Five financial years as mentioned in A above.
C	Similar Work	<p>The bidder should have successfully executed “Soil investigation work in substation/power plant/transmission line/infrastructure project” during last seven years ending on 31.03.2024 and should be either of the following:</p> <p style="padding-left: 40px;">i. Three similar jobs executed costing (except service tax/GST) not less than Rs. 4,22,484/-each.</p> <p style="text-align: center;">OR</p> <p style="padding-left: 40px;">ii. Two similar jobs executed costing (except service tax/GST) not less than Rs. 5,28,105/- each.</p> <p style="text-align: center;">OR</p>

		iii. One similar job executed costing (except service tax/GST) not less than Rs. 8,44,968/-.
D	Additional Qualification	In addition to Sl. No. C above, the bidder should have experience of electrical resistivity test & topographic survey work.

Note:

1. Experience mentioned at Sl. No. D above may be included in work order furnished towards Sl. No. C or separate work order of any value.
2. The Bidder shall submit Contract Agreement/Work Order/LOI with BOQ/Performance/completion/execution certificate issued by customer/ contractor or any other document accepted to BHEL along with technical bid in support of qualification.
3. The word 'executed' means the bidder should have achieved the criteria specified in the PQR. Only those work credentials will be considered that already completed and completion certificate available for that work.
4. In order to technically qualify in this tender, bidder should meet all criteria i.e. A, B, C & D mentioned above.
5. If the job is executed in the last seven years period, as specified above, even if it has been started earlier, the same will also be considered meeting the qualifying requirements.
6. Consortium/ JV bidding is not allowed.
7. BHEL reserves the right to:
 - (a) Accept or reject any bid received at its discretion without assigning any reasons whatsoever.
 - (b) Postpone the above-mentioned date, split and distribute the work among more than one bidder without assigning any reason whatsoever.
 - (c) May ask for further qualification during techno commercial scrutiny of bids received.
 - (d) May ask for further proofs including TDS certificates/ Form 26AS/ Final bill/ payment detail for the said job for cross- verification.
8. BHEL shall not be responsible for any delay, loss, damage for bids sent by post.
9. BHEL shall not be liable for any expenses incurred by bidder in preparation of bid irrespective of whether it is accepted or not.
10. Quotations received from bidders who do not fulfil the PQR shall be summarily rejected without any further evaluation and information to bidders.
11. Canvassing i.e. soliciting favour, seeking advantage etc. in any form is strictly prohibited and any bidder found to have engaged in canvassing shall be liable to have his bid rejected summarily.
12. If the bidder deliberately gives any wrong information in his tender to create in circumstances for the acceptance to his bid, BHEL reserves the right to reject such application.
13. Bidder's selection is subject to approval of BHEL's customer for this work. The approval/acceptance of bidders from Customer is mandatory requirement for subject tender.
14. All corrigenda, addenda, amendments and clarifications to this Tender will be hosted in web page, www.bhel.com and <https://eprocurebhel.co.in> and not in the newspaper. Bidders shall keep themselves updated with all such amendments.

PROJECT INFORMATION

1.0 CUSTOMER:

M/s POWERGRID CORPORATION OF INDIA LIMITED

2.0 PROJECT LOCATION AND DETAILS:

TENDER FOR "SOIL INVESTIGATION & TOPOGRAPHY SURVEY WORK AT 765/400/220KV AT VATAMAN (NEW) & EXTENSION OF 765 KV S/S AT HALVAD IN GUJARAT".

3.0 CONTACT PERSON: FOR CONTRACTUAL ISSUES

DIPAK KUMAR MANDAL
AGM (TBSM)
SUBCONTRACTS MANAGEMENT,
TRANSMISSION BUSINESS GROUP,
Plot No. 25, Sector-16A, Noida,
Distt. Gautambudh Nagar, UP-201301

PHONE: 0120-674-8134/ 99111 63182

E-mail: dipak.mandal@bhel.in

CONTACT PERSON: FOR ENGINEERING ISSUES

Paras Nath Keshri
Sr. Manager (TBEM-Civil)
TRANSMISSION BUSINESS GROUP,
Plot No. 25, Sector-16A, Noida,
Distt. Gautambudh Nagar, UP-201301

PHONE: 0120- 674- 8573 / 9810487322

E-mail: pnkeshri@bhel.in

CONTACT PERSON: FOR CONTRACT EXECUTION ISSUES

R.K. Lal
AGM (TBWS-Construction)
TRANSMISSION BUSINESS GROUP,
C-18, BHEL Township, Gayatri Nagar,
Gotri Road, Vadodara - 390 021

PHONE: 9557494442

E-mail: rajivlal@bhel.in

HSE CONDITIONS

at a **GLANCE** (for bidders)



Health Safety and Environment Management



BHARAT HEAVY ELECTRICALS LIMITED
TRANSMISSION BUSINESS GROUP

	Transmission Business Group HSE Department, HQ, Noida	Doc No. TBG/HSE/NIT-01 Rev No. : 02 Date: 31.01.24
	HSE Conditions at a Glance for Bidders	Page- 1 of 18



Transmission Business Group, Noida

DOCUMENT CONTROL			
Document number:	TBG/HSE/NIT-01		
Issue number:	00	Issue date:	08.01.2020
Revision number:	01	Revision date :	22.10.2021
Revision number:	02	Revision date :	31.01.2024
	Prepared by	Approved and Issued for use by	
Name	Arvind Kumar Pandey	RS Pathwar	
Designation	Sr. Engineer	Dy. General Manager	
Signature	-sd-	-sd-	
Date	31.01.2024	31.01.2024	
Doc. copy issue no. :		Doc. copy issue date :	
Issued to :	Name	Designation	Signature
Issued by :	Name	Designation	Signature

BHARAT HEAVY ELECTRICALS LIMITED

TRANSMISSION BUSINESS GROUP



Transmission Business Group

HSE Department, HQ, Noida

Doc No. TBG/HSE/NIT-01

Rev No. : 02

Date: 31.01.24

HSE Conditions at a Glance for Bidders

Page- 2 of 18

BHEL TBG through its long experience and policy, has developed a culture to consider wellbeing of the society, protection of environment and occupational health and safety of its workers first. TBG has also a culture of transparency in all its business activities. In line to this culture, this NIT annexure is prepared as a peeping window in to the TBG HSE requirements which need to be 100% complied by the successful bidders while executing the contract. Interested bidders should go through these HSE conditions:

1. BHEL HSE Policy



In BHEL, Health, Safety and Environment (HSE) responsibilities are driven by our commitment to protect our employees and people we work with, community and environment. BHEL believes in zero tolerance for unsafe work/non-conformance to safety and in minimizing environmental footprint associated with all its business activities. We commit to continually improve our HSE performance by:

- Developing safety and sustainability culture through active leadership and by ensuring availability of required resources.
- Ensuring compliance with applicable legislation, regulations and BHEL systems.
- Taking up activities for conservation of resources and adopting sound waste management by following Reduce/Recycle/Reuse approach.
- Continually identifying, assessing and managing environmental impacts and Occupational Health & Safety risks of all activities, products and services adopting approach based on elimination/substitution/reduction/control.
- Incorporating appropriate Occupational Health, Safety and Environment criteria into business decisions, design of products & systems and for selection of plants, technologies and services.
- Imparting appropriate structured training to all persons at workplace and promoting awareness amongst customers, contractors and suppliers on HSE issues.
- Reviewing periodically this policy and HSE Management Systems to ensure its relevance, appropriateness and effectiveness.
- Communicating this policy within BHEL and making it available to interested parties.

June 5, 2018

Atul Sobti
Chairman & Managing Director

Creating  of tomorrow

	Transmission Business Group HSE Department, HQ, Noida	Doc No. TBG/HSE/NIT-01 Rev No. : 02 Date: 31.01.24
	HSE Conditions at a Glance for Bidders	Page- 3 of 18

2. Legal Compliances:

- a. **Statutory Provisions:** All the sub-contractors are to comply with client specific rules and procedures, the National legislations and codes, in particular the following or their revised versions:

Srl. No	Acts/Rules Name	Srl. No	Acts/Rules Name
1	The Factories Act 1948, Amendment Act 1947	11	Contractor labour Act, 1970 (Regulation and abolition)
2	The Environment Act 1986	12	Provident fund Act, 1952
3	Workmen's Compensation Act, 1923	13	Payment of gratuity Act, 1972
4	Building and Other Construction Workers (Regulation of employment and condition of service) Act, 1996	14	Indian Explosives Act and the explosives Rules 2008
5	Buildings and Other Construction Workers Welfare Act, 1996	15	The Gas Cylinder Rules, 2016, Static and Mobile Pressure Vessels (Unfired) Rules 2016
6	Payment of wages Act, 2017 Equal remuneration Act,	16	The Indian Electricity Act 2003 and Indian Electricity Rules 2005
7	Minimum wages Act.1948	17	The Atomic Energy Act, 2015
8	Employers liability Act, 1938	18	The atomic energy (Radiation Protection) Rules. 2004
9	Industrial dispute Act, 1947	19	National Fire Protection Association (NFPA),
10	maternity benefit amendment act 2017	20	National Building Code of India 2016 etc.

b. **Indian Standard (IS) Codes related to HSE**

All the sub-contractors are to comply with client specific rules and procedures, the National legislations and codes in particular the following or their revised versions:

Srl	IS Code	Applies on
1	IS: 4081 -1986	Safety code for Blasting and Related Drilling operations
2	IS: 3764 -1992	Safety code for excavation work



Transmission Business Group

HSE Department, HQ, Noida

Doc No. TBG/HSE/NIT-01

Rev No. : 02

Date: 31.01.24

HSE Conditions at a Glance for Bidders

Page- 4 of 18

3	IS: 5121 -1969	Safety code for piling and other deep foundations
4	IS: 2750 -1964	Specification for steel scaffoldings
5	IS: 3696 (Part-I)-1987	Safety code for scaffolds and Ladders: Part- I Scaffolds
6	IS: 3696 (Part-II) -1991	Safety code for scaffolds and Ladders: Part –II Ladders
7	IS: 4082 -1977	Recommendations on stacking and storage of construction materials at site (First revision)
8	IS: 4130-1976	Safety code for demolition of building (First revision)
9	IS: 4912-1978	Safety requirements for floor and wall openings, railings and toe boards (First revision)
10	IS: 5916- 1970	Safety code for constructions involving use of hot bituminous materials
11	IS: 7205 -1974	Safety code for erection of structural steel work
12	IS: 7969 -1975	Safety code for handling and storage of building materials
13	IS: 8989 -1978	Safety code for erection of concrete framed structures
14	IS: 7293 -1974	Safety code for working with construction machinery
15	IS: 2212 -1991	Pipe lines –Identification –Colour code
16	IS: 5216 -1982	Recommendations on safety procedures & practices in Electrical works (Part -I &II)
17	IS: 875 -1964	Code of practice for structural safety of buildings and loading standards
18	IS: 10386 -1983	General aspects Part-1 -1983, Part-2 -1982, Part-6 -1983, Part-10 -1983- Amenities, Protective clothing and equipment, construction, storage, handling, detection and Safety measures for gases, chemicals and flammable liquids
19	IS: 10500-2012	Drinking water (Specification)
20	IS: 10291 -1982	Code of dress in civil engineering works
21	IS: 2925-1984	Safety helmets
22	IS: 1179-1967	Welding helmets
23	IS: 7524 -1979 (Part-I)	Safety goggles
24	IS: 9167 -1979	Ear muff /Ear plugs
25	IS: 6994 -1973 (Part-I)	Canvas hand gloves, Cotton hand gloves, Chrome leather gloves
26	IS: 4770 -1991	Rubber hand gloves tested for 15,000 volts
27	IS: 3521 -1999	Full body safety harness
28	IS: 11057 -1984	Specification for Industrial safety nets

	Transmission Business Group HSE Department, HQ, Noida	Doc No. TBG/HSE/NIT-01 Rev No. : 02 Date: 31.01.24
	HSE Conditions at a Glance for Bidders	Page- 5 of 18

29	IS: 13415 -1992	Protective Barriers in & around buildings (Code of safety)
30	IS: 13416 -1992	Preventive measures against Hazards at work places-Recommendations part-I Falling materials hazards Prevention part-I
31	IS: 13416 -1992	Preventive measures against Hazards at work places-Recommendations part-II Fall Prevention
32	IS: 15298 -2011 (Part 1&2)	Personal Protective Equipment -Safety shoes
33	IS: 12254 -1993	Poly vinyl chloride (PVC) industrial boots
34	IS: 5557:2004	Industrial and Protective Rubber knee and Ankle boots
35	IS: 2878 -2004	Co2 Type fire extinguisher
36	IS: 2171 -1999	Dry chemical powder fire extinguisher
37	IS: 13849 – 1993	Fire extinguisher for ABC fires
38	IS: 10204-2001	Mechanical Foam type extinguisher (Foam used shall conform to IS: 4989 -1974 and Co2 cartridge shall conform to IS: 4947 -1985)
39	IS: 3786 -1983	Methods for computation of Frequency rate and Severity rates for Industrial injuries and classification of Industrial accidents (First revision)

c. The Sub-contractors need to

- Attend HSE familiarization program at TBG-HQ with his site management team. This will be a half day long awareness session on HSE requirements and compliances which the agency is supposed to fulfil during contract execution at site. The session shall be taken by TBG HSE department on intimation by TBSM. **(Rev-01)**
- Request for issuance of Form-V in their name from customer on behalf of BHEL
- Get the Labour license registration from concerned Labour office.
- Get the BOCW Registration done along with the labour license.
- Get their labourers registered under BOCW for benefits provided by the office.
- Maintain Seven registers of labours as per BOCW requirement.
- Ensure payment of wages to labours not less than the current minimum wages applicable in the premises.
- Ensure PF deduction of labourers and submission of proof to BHEL office (Wage sheet, ECR & Challan copies) duly signed.
- Submit Labour Payment Certificate by 10th of Every month.
- File timely returns, get renewals done and submit a copy to BHEL office.

	Transmission Business Group HSE Department, HQ, Noida	Doc No. TBG/HSE/NIT-01 Rev No. : 02 Date: 31.01.24
	HSE Conditions at a Glance for Bidders	Page- 6 of 18

- Get Workmen's Compensation policy before the start of work, covering all the labourers and staff,
 - Policy should clearly mention the project name and location,
 - should be as per labour class and wage.
 - Should cover all the height workers with clear mention of Max. height.
 - Policy should be submitted to BHEL office and renewal before expiry.
- Issue employment card to every worker.

3. Labour Welfare and Medical Facilities

a. Labour Welfare

1. Declaration of normal working hours and weekly off day, Payment day & intervals
2. Paid rest days & holidays.
3. Payment of overtime @ twice the normal wage rate.
4. No labour shall be allowed overtime >12 hrs/week, limited to 48 hrs/month.
5. Rest and lunch area.
6. Separate Male/Female Toilets and Lavatories, clearly marked in local Language and provided with signage.
7. Cold and clean drinking water facility suitable to strength and near workplace
8. Creche for children of female workers as per BOCW requirements
9. Arranging labour accommodation in hygienic environment with the facilities of Water (Drinking, Sanitation), washing and bathing area, toilets in sufficient nos., clean and safe camps and surrounding, access road, well illuminated camp and roads, mode of contact, transport facility, first aid centre, 24x7 Security etc.
10. Cooking and eating place to be maintained in hygienic condition
11. General awareness of health and hygiene.

	Transmission Business Group HSE Department, HQ, Noida	Doc No. TBG/HSE/NIT-01 Rev No. : 02 Date: 31.01.24
	HSE Conditions at a Glance for Bidders	Page- 7 of 18

b. Medical facilities and Health centres

- Availability of first aid box at every work location and agency office, with contents as per BOCW requirement.
- Emergency vehicle (four-wheeler) at work place
- Availability of stretchers in emergency vehicle and in office.
- Trained first aider
- Medical check-up for all the supervisors and workers including cooks, at the time of induction and annually thereafter.
- Tetanus Vaccination for all in every six months.
- Identification and tie-up with nearby reputed hospital(s) and display of their contact number in Emergency contact list.

4. House Keeping & Storage

Housekeeping is a continuous process and is the part of work. Agencies shall maintain safe and presentable housekeeping all the time in their respective areas, common work locations and passage areas. Roads, passages, staircases, entrance/exit gates shall always be maintained obstruction free. No material shall be left or stacked at the roof edges. Agency shall make arrangements to remove scraps on regular basis and dispose them at a space provided by customer, clearly fenced and marked by the sub-contractor as **“SCRAP YARD”**. Suitable arrangement like dedicated housekeeping team and tractor/hydra should be identified for this work.

Construction materials like shuttering materials, staging materials, cables, re-bars, cements bags, earthing flats and rods, FF pipes, surplus soil etc should be stored/stacked properly such that it should neither pose threat to safety of man nor should obstruct the free movement of man and machineries.

Every sub-contractor should have separate and well-maintained storage area for his own materials, T&Ps, PPEs and BHEL issued materials. Consumables like diesel, cotton, grease, oil, paint, admixtures and other fire potential materials should be stored separately with suitable firefighting facility.

Fire capacity of store area to be assessed and accordingly fire extinguishers shall be planned suiting the class and capacity of fire. Sand heaps may also be stacked in open store yards suitably to use in case of fires.

	Transmission Business Group HSE Department, HQ, Noida	Doc No. TBG/HSE/NIT-01 Rev No. : 02 Date: 31.01.24
	HSE Conditions at a Glance for Bidders	Page- 8 of 18

5. Site Safety

a. Induction and others safety trainings

Every sub-contractor shall make arrangement to provide induction training as per BHEL and/or customer requirement on a pre-approved and fixed module to all its new inductees irrespective of class or grade of appointment/hire. He shall also arrange the required facilities for induction training such as board, marker, dummy, posters/banners with all the mandatory PPEs.

Sub-contractor shall also arrange for periodic trainings on fire-fighting, first aid, CPR, importance and use of PPEs, electrical safety, hot work safety, Height work safety, confined space, deep excavations and barricading, concreting work safety etc.

b. Appointment of Safety Officer/Supervisor

Every sub-contractor shall appoint full time **safety officer(s)** as per **Schedule VIII of BOCW Act-1996**. The safety officer so appointed, shall not be assigned any duty/work other than assisting in fulfilment of legal and contractual obligations at site. He shall perform his duties in line to meet the requirements of TBG HSE MANAGEMENT SYSTEMS, such as ensuring daily TBT, conducting induction and other HSE training and awareness programs, organising HSE campaigns, health check-ups, periodic mock drills, reporting & record keeping and other such compliances as per **HSE Plan for Site Operation (TBG/HSEP-14)** on regular basis. **(Rev-01), (Rev-02)**

c. Safety organisation, Safety committees and meetings

Safety officer shall report directly to the head of the projects of the sub-contractor management. There shall be some appointed or nominated **safety stewards** from each sub-group like shuttering, bar-bending, concreting, brick work, material handling, structure erection, cable laying, pipe work, maintenance, batching plant, housekeeping, etc.

A **safety committee** shall be formed including members from different agencies, BHEL and customer covering at-least 50% participation from workers. Safety committee shall meet on weekly basis or as may be decided by customer, outcomes shall be complied as committed.

d. Personal Protective Equipment.

Unless mentioned otherwise, there will be three mandatory PPEs- Safety shoes, Safety Helmet and Reflective jackets conforming to relevant IS codes as mentioned above. Every person entering in the project premises shall use above mandatory PPEs.

There will be other PPEs too, based on the work requirement like: Twin lanyard full body harness, fall arresters and life lines for height workers, Face shield for welders and grinders, Induction helmets and Electrical resistant shoes with FRP/PVC toe for electricians and commissioning engineers, Gum boots for concrete workers and manual excavators, Goggle for gas cutters and grinders, Aprons for welders, shoulder pads for material handlers, Hand gloves – Leather for binders/welders/grinders, certified Rubber gloves for electricians, PVC for concrete/cement

	Transmission Business Group HSE Department, HQ, Noida	Doc No. TBG/HSE/NIT-01 Rev No. : 02 Date: 31.01.24
	HSE Conditions at a Glance for Bidders	Page- 9 of 18

handlers, cotton-housekeeping team/brick coolies/erectors, cable laying men and other material handlers. Dust mask for cement handlers.

e. Material Handling

BHEL as a policy discourages continuous manual handling. Material handling contributes a major portion in the project and hence proper means (mechanical/ electrical powered) should be deployed appropriately for this work. Cranes/Faranas/hydras should not be used for material transportation for long distances(>100m), if such movement is un-avoidable, it must be accompanied by a trained signal man. Long materials should be guided by tagline. Roads for material movement should be free from obstructions. Lifting appliances must be in good condition and must have test/inspection certificates.

Lifting tackles like- D-shackles, chains, ropes, slings, belts shall be periodically inspected and shall have valid test certificate and/or third-party inspection certificates.

Painted/galvanized structures/materials to be lifted by adequate capacity nylon belts only.

If a machine undergoes a major maintenance, fresh TPI shall be required before use.

Hydraulic/pneumatic machines shall be free from leakages. Daily checklist to be filled and witnessed by the concerned supervisor before start of the work.

f. Vehicle/Machinery Documents and other safety requirements

- **Crawler mounted boom cranes/Tyre mounted telescopic cranes/tower cranes**
 1. Valid third-party inspection certificate.
 2. Valid Insurance policy
 3. Registration Certificate (if applicable)
 4. Valid Pollution under control (PUC) (if applicable)
 5. Fitness certificate from RTO (if applicable)
 6. Operator's valid license, experience and/or competence certificate.
 7. Swing horn
 8. Reverse horn
 9. Boom aviation light
 10. Approved Load chart (inside cabin)
 11. Fire extinguisher (inside cabin)
 12. First aid kit (inside cabin)
 13. Boom angle indicator
 14. Hook Latch
 15. Reflector strips on around cabin and on boom
- **Loader backhoe (JCB), crawler excavators (Poclain), Hydra,**
 1. Valid third-party inspection certificate.
 2. Valid Insurance policy
 3. Registration Certificate (if applicable)
 4. Valid Pollution under control (PUC) (if applicable)

	Transmission Business Group HSE Department, HQ, Noida	Doc No. TBG/HSE/NIT-01 Rev No. : 02 Date: 31.01.24
	HSE Conditions at a Glance for Bidders	Page- 10 of 18

5. Fitness certificate from RTO (if applicable)
6. Operator's valid commercial license, experience and/or competence certificate.
7. Reverse horn
8. Approved Load chart (inside cabin) (Hydra)
9. Fire extinguisher (inside cabin)
10. First aid kit (inside cabin)
11. Hook Latch (Hydra)
12. Reflector strips on around cabin and on boom

- **Tipper, Transit mixtures (TM), Self-loading concrete mixture (Ajax Fiori), Tractors**

1. Valid third-party inspection certificate.
2. Valid Insurance policy
3. Registration Certificate
4. Valid Pollution under control (PUC)
5. Fitness certificate from RTO
6. Operator's valid commercial Heavy license, experience and/or competence certificate.
7. Reverse horn
8. Fire extinguisher (inside cabin)
9. First aid kit (inside cabin)
10. Reflector strips on around cabin and on body

Note: 1. Tractors may be allowed with Light Commercial/non-commercial license on customer's consent.

- **Cars, Taxis, scooters, motor cycles and other public carriers**

- Valid 2/4-wheeler license (as applicable- commercial/non-commercial)
- Registration Challan
- Valid Insurance
- Pollution under control

g. Man-lifts (Cherry pickers), Scissors Lifts

1. Trained operator with experience/competence certificate and license
2. Valid third-party inspection certificate.
3. Valid Insurance policy
4. Registration Certificate (if applicable)
5. Valid Pollution under control (PUC) (if applicable)
6. Swing horn
7. Reverse horn
8. Boom aviation light
9. Fire extinguisher (inside cabin)
10. First aid kit (inside cabin)
11. Reflector strips on around cabin and on boom

	Transmission Business Group HSE Department, HQ, Noida	Doc No. TBG/HSE/NIT-01 Rev No. : 02 Date: 31.01.24
	HSE Conditions at a Glance for Bidders	Page- 11 of 18

Note:

1. No one shall ride man-lift bucket without safety belt, safety shoes, helmet and reflective jacket.
2. Not more than 3 persons at a time will board in bucket of man-lift (without any heavy materials) including operator.
3. Operator will not leave the machine while persons are elevated and working.
4. No one other than the authorised operator will operate the man lifts/Scissors lifts.

h. Excavation

Prior permission/clearance from customer is a must for excavations in areas where underground service services such as gas/water/oil/chemical/electrical lines may be routed. Due precautions shall be taken during excavation in such area. Excavations near water bodies (ponds/canals etc.) shall be done with sand/soil bags ready to plug water from accidental damaged/burst of edges. All the excavations shall be done by either step cutting (min. 600mm step at every 1.5m depth) or slope cutting at 1:2(X:Y axis) (or greater depending upon the soil condition). Where step cutting/slope cutting is not possible due to space constraints, shoring/shuttering or sheet piling to be used to check collapse of soil.

Excavated soil shall be stacked away from edge of the pit, at-least 1.5 meters or half of the depth whichever is higher. Height of the stack shall not exceed 2m in height.

Ramps shall be provided for access of the workers in large pits and ladder of metal/good built for small pits. Ladders shall be of sufficient length protruding at least 1m above the ground level.

Pumps of adequate capacity shall be available for pumping out of water. No lone worker shall be allowed to work in any excavation. Overloaded vehicle shall not be allowed near excavated pits.

i. Bar bending and Binding

Bar bending machine shall be installed under shed/roof. It shall be properly earthed and maintained for operation. Housekeeping of the area shall be team's responsibility on daily basis. All be bar benders shall be given hand gloves (leather/cotton) in addition to mandatory PPEs. Scrap shall be segregated and moved to scrap yard on regular basis. Bar bending station shall be located away from Main plying roads/passages. The station shall be well illuminated, shall have a maintained first aid kit and potable water. Station shall be located in such a way that the movement of the material be minimised.

j. Concreting

No electric vibrators shall be allowed to use. All the concrete workers shall be issued gum boots, safety helmets, reflective jackets and PVC hand gloves. Free fall of concrete from chute shall not exceed 1m in height. Heavy machineries/ vehicles shall be kept at least 2m away from the edge. Emergency vehicle shall be available near concreting work. Late night works shall be avoided, if it is unavoidable, a prior permission from BHEL/Customer is mandatory.

	Transmission Business Group HSE Department, HQ, Noida	Doc No. TBG/HSE/NIT-01 Rev No. : 02 Date: 31.01.24
	HSE Conditions at a Glance for Bidders	Page- 12 of 18

k. Welding, Gas Cutting & other hot works

Welding: Only experienced welders should be deployed for welding jobs. Welders shall be provided with apron, hand gloves, arm pads, leg pads, face shield and safety shoes. Welding leads shall be joint less and insulated. Power input point shall be fully covered at machine.

Gas cutting: If LPG is being used, domestic cylinder is strictly prohibited inside the project premises, (not allowed for site kitchen too). Hose pipes shall be in good condition without cracks, cuts, punctures or joints. Ends should be clamped with worm clamps. Dial gauges shall be of good quality and duly calibrated. Flash back arresters is a must for both oxygen/acetylene or LPG/Oxygen combination. Cylinders shall be stored, transported and used in vertical position only. When not in use, they shall be capped. Empty and filled cylinders to be stored separately with distinct marking.

Cylinders shall neither be rolled on the ground nor thrown during loading/unloading.

Grinding: Grinder shall be given clear glass face shield, apron, safety shoes, ear muffs and hand gloves. Grinder machines shall have wheel guard. Plug tops to be used for power connection preferably three wire type. Only trained persons shall be allowed to use grinders, abrasive cutters. Electrical connection shall be free from cuts, joints etc.

l. Erection & Height Work

Only trained filters and experienced helpers shall be engaged in erection work. Step bolts of lattice towers shall be checked for full tightness with spring washers before use. Height pass shall be issued to the identified group of erectors who have passed medical test and have working experience at height. Name of such workers shall be displayed at appropriate place. These workers only shall be allowed to work at height. Height work shall not be permitted in high wind/bad weather condition, during raining or in night/dark.

m. Electrical Safety

BHEL usually provided single point power source and sub-contractors draw power from there. Otherwise agencies make their own arrangement for construction power like DG sets etc. Sub-contractors shall submit their load requirement (amperage & phase) to BHEL before start of work. Accordingly, they shall make arrangements to draw power and distribution arrangements too in a safe way. MCCBs and HRC fuses to be put in circuit for short circuit and overload protections and RCCBs of 30mA sensitivity to be put at each distribution panel for human safety. Earthing pits shall be installed at each distribution point and maintained below three Ohm resistivity which shall be inspected randomly. The distribution points shall be clean, free from vegetation and water logging, easily accessible and covered/protected from three sides and top for rain. Earthing of DBs shall be done by 25x3mm GI flats connected from proper earth pits. Insulation mat, PVC Sheet/Wooden plank to be placed before DBs as platform. DB Sheds shall be legibly marked with name of agency, contact no of electrician and SLD of that DB. Only industrial plugs and sockets shall be allowed. Three wire (Phase, neutral and earth) system shall be used for tools, lights and machineries and two wire power draws shall be strictly prohibited. PTW and LOTO system shall be maintained to work on LT system. Name and contact no of authorised electricians who will be responsible of electrical power facility maintenance shall be submitted to BHEL by Agencies. Unauthorised sharing of power from one agency to other is strictly prohibited. Electricians shall use standard PPEs and insulated

	Transmission Business Group HSE Department, HQ, Noida	Doc No. TBG/HSE/NIT-01 Rev No. : 02 Date: 31.01.24
	HSE Conditions at a Glance for Bidders	Page- 13 of 18

tools only. Standard and tested/certified discharge rods to be used in the areas where there is a possibility of residual current or induction charge. The induction rod to be connected to the earth first and removed in the last. Induction helmets only to be used in the charged area. Electricians to be provided with electrical resistant safety shoes having FRP/PVC toe.

n. Dust Gases and fumes

Sub-contractor shall make arrangements to avoid accumulation of dust fumes and gases. Cement handlers inside store or at batching plant and gravel spreader shall be given effective nose masks and jaggery (at least 200g per person per day). DG sets and other machineries like cranes excavators etc. shall have valid and effective PUC certificate and shall have maintained engine with silencer. No IC engine operated machine shall be used in confined and covered area like hall, sheds, store etc. where accumulation due to lack of ventilation can increase to harmful levels. Dedicated arrangements (tanker or tractor with sprinkler) shall be made by the sub-contractors (individual or jointly) to continuously subside the dusts arising out of the movement of the vehicle's roads/passages. Welding activities near roof accumulates harmful gases. Welders in such positions shall be provided with effective masks conforming to IS standards.

o. Vehicular Traffic

Speed limits defined within the premises shall strictly be followed by the drivers/commuters of construction as well as other vehicles.

Every construction machinery, man-lift shall display the name, contact no and passport size photograph of the authorised operator (There can be one or more authorised operators).

No one other than operator and co-operator shall sit inside the cabin of any construction machine while it is working.

Construction machineries (tractor, trucks, tippers, JCBs, hydra, Fassi cranes etc. shall never be used as mode of public transport. Machineries like Ajax Fiori and hydra shall not be driven in back direction except for small distances. No overloaded vehicle shall be permitted entry in the project premises.

Over speeding shall be reported and driver/operator shall be barred from entry or shall be penalised.

Drunken drivers shall be barred from entry in the project.

Carrying harmful weapons like knives (>6"), guns etc. shall permanently disqualify the person from entry in project premises.

p. Barricading and floor openings

Every pit deeper than 4 feet (1.2m) shall be barricaded immediately after excavation and will remain barricaded till backfilling.

Pits/trenches drains near roads, passages whether temporary or permanent shall be hard barricaded and well illuminated. Roof edges and openings shall be strictly hard barricaded and illuminated. Height works like masonry works, structure erection, erection by cranes, Lattice tower/beam erection areas shall be barricaded to restrict entry. Areas under charging/commissioning shall be barricaded and caution boards shall be displayed on newly charged areas.

	Transmission Business Group HSE Department, HQ, Noida	Doc No. TBG/HSE/NIT-01 Rev No. : 02 Date: 31.01.24
	HSE Conditions at a Glance for Bidders	Page- 14 of 18

q. Scaffold & Ladder

No bamboo/wooden scaffold shall be allowed to be used. Only tubular steel scaffolds with couplers conforming to the relevant IS codes shall be allowed with base plates. Standard steel or wooden planks to be used as platforms and no packing materials shall be used. All the platforms shall be built with provisions of **top rail at 1m height, mid rail at 0.5m height and toe boards of min 6" height** at floor level. Minimum width of platform shall be 900mm and if wheel barrow is to be used then 1200mm. Means of access to be provided in the form of ladders, ramps or staircase. Multilevel work platforms or those platforms having passage underneath shall be provided with safety net, screen or canopy at each level for protection from falling objects. Platforms shall be free from concrete, debris or other materials. Platforms shall not extend out of the putlogs and shall be secured and fastened. Decking shall be made non-skidding.

Scaffolds under erection shall be tagged "**RED**", under repair/maintenance/inspection shall be tagged "**YELLOW**" and ready for use shall be tagged "**GREEN**"

Only metal ladders in the construction site and FRP ladders in charged areas shall be allowed. Ladders made from packing materials shall not be used. Ladders shall be securely fixed at bottom, top and long ladders at middle points too at an interval not more than 2400mm and must have a landing at every 6m. Inclination angle should be approximately 1:4 (X:Y) or 75deg. Ladder must extend at least 1m above the platform/access area. Gap between two rungs shall not exceed 300mm. Portable ladder should not be more than 4m in length. Minimum width of the ladder shall not be less than 300mm.

Use of Mobile aluminium scaffold is preferably advisable for erection of transformers/reactors.

r. Illumination

The sub-contractor shall ensure that the areas such as work stations, buildings, batching plants, passages/roads, stores, rest areas, power sources, staircases etc. are illuminated sufficiently to make safe work conditions at site and shall not be less than the relevant IS standards. Excavations/ below ground level structures near passages/roads shall also be sufficiently illuminated.

s. Safety banners/posters, caution boards

Sub-contractors shall display boards and banners in sufficient quantity having safety signs, slogans, important messages, pictures, cautions at prominent locations to promote safety and spread awareness for important precautions such as "Deep Excavation Ahead", "Speed Limit", "Charged Area", "Do not operate", "Hard hat area", "No smoking Zone" etc. Boards containing messages of Emergency contacts, First aid facility, rates of minimum wages, working hours, rest day etc. should be displayed at specific areas.

t. Waste management and disposal

Sub-contractor shall make suitable and effective arrangement to remove waste material from site on regular basis and store them in an identified and safe location. Disposal of wastes shall also be done as per manufacturer's instructions or as per the guidelines laid by legal authorities. Re-bars, Cement bags, packing material (wooden/metal/plastic/paper), paint, oil, grease, cables (armour, sheathing, insulation),

	Transmission Business Group HSE Department, HQ, Noida	Doc No. TBG/HSE/NIT-01 Rev No. : 02 Date: 31.01.24
	HSE Conditions at a Glance for Bidders	Page- 15 of 18

civil debris, metal chips, GI sheet scraps, batteries etc. are the common waste materials. Sub-contractor shall arrange disposal of the hazardous wastes/materials in conformance to the legal and contractual requirements only.

u. Inspection of PPEs, T&Ps, Machineries and lifting appliances

All the PPEs, T&P and lifting appliances purchased newly by sub-contractors shall have test certificates which shall be submitted to BHEL office periodically or on demand. There shall be at least monthly joint inspection schedule for inspection of healthiness of all the PPEs, T&Ps and lifting appliances. All the lifting appliances shall be tested and examined by a competent person before taking into use for the first time or after it has undergone any alterations or repairs liable to affect its strength or stability

and also once at least in every twelve months. To confirm quality of the PPEs as per the relevant IS codes, BHEL may ask sub-contractors to get any or all types of PPEs tested through NABL approved lab as per relevant IS codes. At any stage, the 100% cost of such tests shall be in the scope of respective sub-contractors.

v. Cable Laying

Sub-contractor shall ensure cable trenches free from water, mud, debris, snakes, Scorpios, lizards before start of the work in trenches. Cable drum rollers shall be used to pull cables out of drums to avoid twisting of cables. Hand gloves, Safety shoes/gum boots, reflective jackets, safety helmets shall be provided to the workers. Cable laying area shall be well illuminated.

w. Fire Protection

Every sub-contractor has to maintain their working area, store and office area free from bushes. Stacking of flammable materials like wood, paper, plastic, paint, oil, grease, fuel, cotton, gases etc. at isolated place disconnected from other storage and office areas. Adequate arrangements of firefighting means like suitable extinguishers, fire/water buckets, water tanks, sand dunes etc. shall be made by the agency depending upon the fire capacity assessed or as per MSDS. Fire drills and trainings on how to operate fire extinguishers and how to react in case of fire breakouts shall be the part of regular training program. Guards and store persons must be a regular participant of such training programs. A list of trained firefighting persons and periodicity of such training programs shall be submitted to BHEL by every agency and same to be adhered. Sufficient number of fire extinguishers with suitable class shall be placed at such locations where there can be fire hazard like stores, pantry, office, DG set, electrical distribution panels etc.

x. Fencing of exposed rotating parts

Exposed rotating parts poses great threat to the person in vicinity. Such parts need to be fenced/covered. Guards are mandatory of grinders, abrasive cutters. Flywheels of the engines of heavy machines, Diesel engines, DG sets need to be covered. Electric winch machines, pulleys, chains, shafts, exhaust fans at reachable height, table fans, need to be caged/fenced. Such fencing/guard shall not be removed while machinery is in operation.

	Transmission Business Group HSE Department, HQ, Noida	Doc No. TBG/HSE/NIT-01 Rev No. : 02 Date: 31.01.24
	HSE Conditions at a Glance for Bidders	Page- 16 of 18

y. Emergency preparedness response plan and periodic mock drills.

Sub-contractor shall comply JSA (Job Safety Analysis) and arrange to mitigate the effects of identified possible hazards. He shall also define following in response to emergency preparedness:

An emergency assembly point and put a board of the same with information to all in induction training.

Have facility of ambulance or tie-up with nearest hospital for service in minimum possible time (Max-30min) if there is not ambulance inside the premises.

Ensure availability of emergency vehicle with driver all the time at site during work.

Conduct mock-drills on possible risks like electrocution, fall from height, fire, heat stroke etc., record responses and take photographs to submit in BHEL office. Stretchers availability in emergency vehicle or at work place should be well accessible. Provide fire extinguishers of right type at right place in right quantity with information to all. Display emergency contact nos. to various risk locations and at office, service building or at major work locations. Provide first aid training by doctors for and display names of such trained first aiders and fire fighters. Rescue kit with trained staff or man lift or both to rescue a man hanging by safety belt at height. Provide running water tap near chemical storage and handling points. Agencies shall follow emergency response plan prepared by BHEL in each area of work, store and office.

z. Safety reports & Reporting of accidents

BHEL will provide “formats and checklists” for the purpose of records/documents pertaining to the compliance of aforesaid clauses. Agencies shall be responsible for strict adherence and compliance for timely generation and fill-up of the checklists and reports. These shall be submitted on weekly and monthly basis as specified in the formats.

Agency shall also promote such an environment that the near misses, incidents and accidents are reported by every person, whosoever witnesses them. These shall help in analysing the trend and taking measures in reducing/stopping the accidents/incidents. Initial reporting can be in any form-by call, SMS, WhatsApp, e-mail, letter etc.

Major and fatal accidents or high potential incidents shall be investigated for route cause and outcomes shall be immediately implemented to check recurrences.

6. General conditions and penalty clauses

Following are the general conditions:

PPEs shall not only bear the ISI mark but also be conforming to the required standards, 100% compliance of the PPEs is mandatory.

Over speeding of vehicles shall attract penalty/notice and recurrence will attract debarring from entry into project premises.

Hiding of facts like incidents, accidents, fake/forged reports/certificates shall also attract penalty/ notice or both. Only approved third party agencies shall be allowed to inspect the machines, T&Ps. Reports shall directly be sent to BHEL/customers by the third parties.

	Transmission Business Group HSE Department, HQ, Noida	Doc No. TBG/HSE/NIT-01 Rev No. : 02 Date: 31.01.24
	HSE Conditions at a Glance for Bidders	Page- 17 of 18

Insurance and TPIs to be renewed before expiry. Machines, T&Ps shall not be allowed to work if renewal delayed. Continuity of WC policy to be maintained religiously by the respective agencies.

Agency shall submit the status report of his labour license, BOCW registration, WC Policy, insurance & TPI validity on monthly basis with list of machineries and T&Ps

Sub-contractors shall also maintain a buffer stock of all the PPEs in at least 20% excess to the present strength of the work force.

If construction power is not drawn as per the guidelines laid in clause no. 5(m), given above, BHEL may take-up this work at the risk and cost of the agency and/or may withhold a sum of min. Rs. 50,000/- (Rs. Fifty Thousand) or more as the site in-charge deems fit till the system is aligned as per aforesaid requirement.

Agencies shall be responsible for the compliance of the above requirements. Failure in one or more clauses/area shall attract a notice or monetary penalty or a combination of above.

Monitory penalty will be

- Rs. 1000/- per person/incident per day for non-conformity in above areas.
- A Major/severe accident shall attract a penalty of Rs. 2,00,000/- per head
- Fatality or permanent disability with total loss of earning capacity, if any, will attract a penalty of Rs. 5,00,000/- (Rs. Five Lakh).
- Further fatality/permanent disability shall attract double the last penalty imposed on the agency.
- Above penalties are exclusive of medical expenses of the victim or compensation to the family through insurance policy (WC Policy or group insurance).
- **Penalties imposed by customer shall be fully transferable to the sub-contractor. In the event of above cases, penalties shall be imposed whichever will be higher.**
- Evaluation of agency's performance on HSE compliance shall be done as per BHEL guide lines/system.

	Transmission Business Group HSE Department, HQ, Noida	Doc No. TBG/HSE/NIT-01 Rev No. : 02 Date: 31.01.24
	HSE Conditions at a Glance for Bidders	Page- 18 of 18

Revision History

Revision Date	Revision No.	Old Text	New Text	Reason	Revised by (with sign)
03.05.2019	00	N/A	Full Document	New Release	
12.10.2021	01	Nil	Attend HSE familiarization program at TBG-HQ with his site management team. This will be a half day long awareness session on HSE requirements and compliances which the agency is supposed to fulfil during contract execution at site. The session shall be taken by TBG HSE department on intimation by TBSM. (at page no. 5)	For better understanding of HSE requirements to agency. (HSE Review meeting dated 23.08.2021)	
12.10.2021	01	Edition	Inclusion of penalty provisions in case of non-deployment of safety person(page-8)	Introduction of HSEP-14	
17.01.2024	02	Edition	Appointment and duties of qualified safety officer (Page-8)	As per BOCW 1996	

-:End of Document:-



BHARAT HEAVY ELECTRICALS LIMITED

TRANSMISSION BUSINESS GROUP

(Subcontract Management)

PLOT NO.- 25, SECTOR-16A, NOIDA-201301

Tender Spec. no.: TBSM/VATAMAN & HALVAD/SI/TENDER/23-24, Date: 02.04.2024

TERMS & CONDITIONS OF CONTRACT

The following terms and conditions shall form a part of the tender document.

1.0 GENERAL INSTRUCTION

1.1 **All pages of the tender documents shall be duly signed, stamped and submitted along with the offer in token of complete acceptance thereof.** The information furnished shall be complete by itself. The tenderer is required to furnish all the details and other documents as required in the following pages.

1.2. Tenderers are advised to study all the tender documents carefully. Any submission of tender by the tenderer shall be deemed to have been done after careful study and examination of the tender documents and with the full understanding of the implications thereof. Should the tenderers have any doubt about the meaning of any portion of the Tender Specification or find discrepancies or omissions in the drawings or the tender documents issued are incomplete or shall require clarification on any of the technical aspect, the scope of work etc., tenderer shall at once, contact the authority inviting the tender well in time (so as not to affect last date of submission) for clarification before the submission of the tender. Tenderer's request for clarifications shall be with reference to Sections and Clause numbers given in the tender documents. The specifications and terms and conditions shall be deemed to have been accepted by the tenderer in his offer. Non-compliance with any of the requirements and instructions of the tender enquiry may result in the rejection of the tender.

2.0 PROCEDURE FOR SUBMISSION OF SEALED TENDERS

2.1 Bidders may please refer CI no. 02 to CI no. 03 of the Notice inviting tender.

2.2 The tenders received after the specified time of their submission shall be treated as 'Late Tenders' and shall not be considered under any circumstances.

2.3 Tenders shall be opened by the officers concerned of BHEL at the time, date and venue as specified in the tender enquiry. Tenderer or their authorized representative may witness the bid opening.

2.4 The tenderer shall closely pursue all the clauses, specifications and drawings indicated in the Tender Documents before quoting. Should the tenderer have any doubt about the meaning of any portion of the Tender Specifications or find discrepancies/omission in the drawings or the tender documents issued are incomplete or shall require clarification on any of the technical aspect, scope of work etc. he shall at once contact the authority inviting the tender for clarification before the submission of the tender.

2.5 Before submission of offer, the tenderer are advised to inspect the work & the environments and be well acquainted with the actual working and other prevalent conditions, facilities available, sourcing of material and labour, means of transport and access to site, accommodation, etc. No claim will be entertained later on the grounds of lack of knowledge on any of these conditions/ resources.



BHARAT HEAVY ELECTRICALS LIMITED

TRANSMISSION BUSINESS GROUP

(Subcontract Management)

PLOT NO.- 25, SECTOR-16A, NOIDA-201301

Tender Spec. no.: TBSM/VATAMAN & HALVAD/SI/TENDER/23-24, Date: 02.04.2024

- 2.6 Tenderer must fill up all the schedules and furnish all the required information as per the instructions given in various sections of the tender specification. Each and every page of the Tender Specification must be SIGNED AND SUBMITTED ALONG WITH THE OFFER by the Tenderer in token of complete acceptance thereof the information furnished shall be complete by itself.
- 2.7 The tenderer shall quote the rates in English Language and international numerals. Total price offered should be entered in figures as well as in words. For the purpose of the tender, the metric system of units shall be used.
- 2.8 **The tenderer shall quote a percentage above/ below/At Par the rates shown in the "Percentage BOQ/Price Schedule/Price bid" of subject tender.**
- 2.9 **The quoted percentage will apply to all the individual items of "Annexure-I i.e Bill of Quantity Cum Price Schedule" uniformly.**
- 2.10 All entries in the tender shall either be typed or be written legibly in ink. Erasing and overwriting are not permitted and may render such tender liable for rejection. All cancellations and insertions shall be duly attested by the tenderer.
- 2.11 The tenderer must provide the registered e-mail of their registered office along with the addresses and authorized phone/mobile nos.
- 3.0 ADJUSTMENT PRICE DISCREPANCY (IES): - Not Applicable being e procurement.**
- 4.0 EVALUATION OF TECHNICAL BIDS**
- 4.1 Technical Bids submitted by the tenderer will be opened first and evaluated for fulfilling the Pre-Qualification criteria and other conditions in NIT/Tender documents, based on documentary evidences submitted along with the offer.
- 4.2 In case the same qualifying experience is claimed by more than one bidder due to subletting of work by main contractor to subcontractor (s) then following conditions shall be applicable.
- a) For labour + consumable contract without material and T&P:
Benefit of work experience shall be given to the subcontractor who has actually executed job and not to the contractor offloaded down the line.
- b) For contract with complete scope i.e. with materials, T&P, labour and consumable:
- i) Benefit of work experience shall be given to the subcontractor who has actually executed job and not to the contractor offloaded down the line.
- ii) If the contractor offloads the labour and/or T&P portion only, Benefit of work experience shall be given to the main contractor and not to the subcontractor who has executed only as labour supply contractor
- The bidders qualification shall be subject to submission of documentary proof. BHEL reserves the right to ask for further proofs including submission of TDS certificates/ for the said job.
- 4.3 In case the qualifying experience is claimed by private organizations based on Work Order and completion certificates from another private organization, BHEL reserves the right to ask for further proofs including submission of TDS certificates/ form 26AS /bills for the said job.



BHARAT HEAVY ELECTRICALS LIMITED

TRANSMISSION BUSINESS GROUP

(Subcontract Management)

PLOT NO.- 25, SECTOR-16A, NOIDA-201301

Tender Spec. no.: TBSM/VATAMAN & HALVAD/SI/TENDER/23-24, Date: 02.04.2024

- 4.4 Credentials of all the bidders participating in open tender will be scrutinized thoroughly by the nominated committee w.r.t. the pre-qualifying requirement for the tender.
- 4.5 Details of qualifying work(s) executed by the bidder will be forwarded to the principle employer for verification of the work with respect to completion, commencement & completion date, scope and value of the work executed. Performance feedback of the bidder will also be sought from the principle employer.
- 4.6 BHEL may conduct onsite verification of at least one of the qualifying work to verify completion of the work and evaluate capability and performance of the bidder.
- 4.7 The bidder representative may be called for the discussion with the committee. His originals may be verified by the committee. In addition to above their organization chart and detailed list of manpower, tools & plants and technical capability may be discussed and ascertained by the committee.
- 5.0 **EVALUATION OF PRICE BIDS**
- 5.1 Price Bids of unqualified bidders shall not be opened.
- 5.2 The offers will be evaluated on the basis of total price basis (refer "BILL OF QUANTITY AND PRICE SCHEDULE) as shown in the price bid.
- 5.3 Reasons for rejection of the bid shall be intimated in due course after issue of LOI/LOA to successful bidder and receipt of unconditional acceptance of LOI /LOA from the successful bidder
- 5.4 In case of electronic Reverse Auction, the unqualified bidders shall not be allowed to participate in reverse auction.
- 6.0 **DOCUMENTS TO BE ENCLOSED:**
Full information shall be given by the tenderer in respect of the following.
- 6.1 Tenders shall be signed by persons duly authorized/empowered to do so. An attested copy of the Power of Attorney to be submitted in all cases except where the sole proprietor is the signatory to the tender documents
- 6.2 **PERMANENT ACCOUNT NUMBER:**
Certified copies of Permanent Account Numbers as allotted by Income Tax Department for the Company / Firm / Individual Partners, etc. shall be furnished along with tender.
- 6.3 **AUDITED BALANCE SHEET AND INCOME TAX RETURN:**
Copy of Audited Balance sheets and income tax return for last Five financial years (financial years as specified in PQR)
- 6.4 **SOLVENCY CERTIFICATE:**
If asked in NIT, bidder should submit solvency certificate (not older than 12 months from date of tender notification) issued by any scheduled bank.
- 6.5 **DOCUMENT RELATED TO INCORPORATION OF BUSINESS ENTITY:**
- 6.5.1 **IN CASE OF INDIVIDUAL TENDERER:**
His/her full name, address and place & nature of business.



BHARAT HEAVY ELECTRICALS LIMITED

TRANSMISSION BUSINESS GROUP

(Subcontract Management)

PLOT NO.- 25, SECTOR-16A, NOIDA-201301

Tender Spec. no.: TBSM/VATAMAN & HALVAD/SI/TENDER/23-24, Date: 02.04.2024

6.5.2 IN CASE OF PARTNERSHIP FIRMS:

The names of all the partners with address. A copy of the partnership deed/instrument of partnership duly certified by the Notary shall be enclosed.

6.5.3 IN CASE OF COMPANIES:

Date & place of registration including date of commencement certificate in case of Public Companies and the nature of business carried on by the company. Certified copies of Memorandum and Articles of Association are also to be furnished.

6.6 Offer forwarding letter over the letterhead

6.7 *Declaration sheets (As per Prescribed format) over the letter head*

6.8 *No Deviation certificates (As per Prescribed format) over the letterhead*

6.9 GST Registration certificate

All the data required to be enclosed with the tender need to be furnished neatly typed, signed & stamped in the given formats only (in the form of separate sheets) failing which the tender may be considered as incomplete and is liable for rejection. Documentary proof wherever necessary also need to be enclosed.

7.0 REJECTION OF TENDER & OTHER CONDITIONS:

7.1 The decision of acceptance of tender will rest with BHEL which does not bind itself to accept the lowest tender or any tender and reserves to itself full rights for the following without assigning any reasons whatsoever:

(a) To reject any or all of the tenders.

(b) To split up the work amongst two or more Tenderer as per NIT

(c) To award the work in part as per NIT

(d) In either of the contingencies stated in (b) and (c) above to modify the time for completion suitably.

7.2 Conditional tenders, unsolicited tenders, containing abnormally low/ unworkable rates & amounts, tenders which are incomplete or not in the form specified or defective or have been materially altered or not in accordance with the tender conditions, specifications etc. are liable to be rejected.

7.3 Tenders are liable to be rejected in case of unsatisfactory performance of the tenderer with BHEL, or tenderer under suspension (hold / banning / delisted) by any unit / region / division of BHEL or tenderers who do not comply with the latest guidelines of Ministry / Commissions of Govt. of India. BHEL reserves the right to reject a bidder in case it is observed that they are overloaded and may not be in a position to execute this job as per the required schedule in line with 'NIT'. The decision of BHEL will be final in this regard.

7.4 In case of any adverse information is received concerning performance, capability or conduct of the tenderer after issue of tender enquiry or opening of tender or award of work, BHEL reserves the right to reject the offer at any stage as deemed fit.

7.5 Offers with inadequate Tools & Plants, Manpower Deployment Plan, and Method Statement are liable for rejection.



BHARAT HEAVY ELECTRICALS LIMITED

TRANSMISSION BUSINESS GROUP

(Subcontract Management)

PLOT NO.- 25, SECTOR-16A, NOIDA-201301

Tender Spec. no.: TBSM/VATAMAN & HALVAD/SI/TENDER/23-24, Date: 02.04.2024

- 7.6 If a tenderer who is a proprietor expires after the submission of his tender or after the acceptance of his tender, BHEL may at its discretion, cancel such tender. If a partner of a firm expires after the submission of the tender or after the acceptance of the tender, BHEL may cancel such tender at its discretion unless the firm retains its character.
- 7.7 BHEL will not be bound by any Power of Attorney granted by the tenderer or by changes in the composition of the firm made subsequent to the execution of the contract. BHEL may, however, recognize such Power of Attorney and changes after obtaining proper legal advice, the cost of which will be chargeable to the contractor concerned.
- 7.8 If the tenderer deliberately gives wrong information in his tender, BHEL reserves the right to reject such tender at any stage or to cancel the contract, if awarded, and forfeit the Earnest Money/Security Deposit/any other moneys due.
- 7.9 Canvassing in any form in connection with the tender is strictly prohibited and the tenders submitted by the tenderer who resorts to canvassing are liable to be rejected.
- 7.10 In case the Proprietor, Partner or Director of the Company / Firm submitting the Tender, has any relative or relation employed in BHEL, the authority inviting tender shall be informed to the fact as per specified format along with the offer, failing this, BHEL may, at its sole discretion reject the tender or cancel the contract and forfeit the Earnest Money/ Security Deposit.
- 7.11 The successful tenderer should not sub-contract the part or complete work detailed in the tender specifications without written permission of BHEL's Site In charge/ Sector Head. For this the contractor shall submit request application to site in charge supported by credentials (financial and technical) and resource mobilization schedule of such sub-contractor. Such request are to be considered in consultation with end user/ultimate customer (if applicable) and subject to satisfactory credentials, fund flow arrangement between them, HSE and other contractual and statutory obligations. The tenderer is solely responsible to BHEL for the work awarded to him.
- 7.12 The Tender submitted by a tenderer shall become the property of BHEL who shall be under no obligation to return the same to the bidder. However unopened price bids and late tenders shall be returned to the bidders.
- 7.13 unsolicited discount received after the due date and time of Bid Submission shall not be considered for evaluation. However, if the party who has submitted the unsolicited discount/rebate becomes the L-I party, then the awarded price i.e contract value shall be worked out after considering the discount so offered.
- 7.14 BHEL shall not be liable for any expenses incurred by the bidder in the preparation of the tender irrespective of whether the tender is accepted or not.
- 8.0 **NO DEVIATIONS ARE ACCEPTABLE:** -
Offers with deviations are likely to be rejected. However, if the bidder insists on any technical or commercial deviations from the specifications and / or tender conditions, **the price implication, if any, of withdrawing the deviations must be submitted along with the price bid in a separate sealed envelope** super-scribed "**PRICE IMPLICATION FOR WITHDRAWAL**



BHARAT HEAVY ELECTRICALS LIMITED

TRANSMISSION BUSINESS GROUP

(Subcontract Management)

PLOT NO.- 25, SECTOR-16A, NOIDA-201301

Tender Spec. no.: TBSM/VATAMAN & HALVAD/SI/TENDER/23-24, Date: 02.04.2024

OF DEVIATIONS". No price implication for withdrawal of deviation shall be accepted at a later date, after opening of technical bid.

9.0 Consortium/ JV bidding is not allowed under this NIT.

10.0 EARNEST MONEY DEPOSIT

Not applicable for this tender.

11.0 SECURITY DEPOSIT

Security Deposit means the security provided by the Contractor towards fulfilment of any obligations in terms of the provision of the contract.

Upon acceptance of Tender, the successful Tenderer should deposit the required amount of Security Deposit for satisfactory completion of work. **The total amount of Security Deposit will be 5% of the Contract Value.** EMD of the successful tenderer shall be converted and adjusted towards the required amount of Security Deposit.

11.1 Mode of Security deposit:

The security Deposit should be furnished before start of the work by the contractor.

"Bidders agrees to submit performance security required for execution of the contract within the time period mentioned. In case of delay in submission of Performance security, enhanced performance security which would include interest (Repo rate + 4%) for the delayed period, shall be submitted by the bidder.

Further, if performance security is not submitted till such time the first bill becomes due, the amount of performance security due shall be recovered as per terms defined in NIT / Contract, from the bills along with due interest".

The balance amount to make up the required Security Deposit of 5% of the contract Value may be furnished in any of the following forms:

- i) Cash (as permissible under the extant Income Tax Act)
- ii) Local cheques of scheduled banks (subject to realization) / Pay Order / Demand Draft / Electronic Fund Transfer, in favour of BHEL.
- iii) Bank Guarantee from Scheduled Banks / Public Financial Institutions as defined in the Companies Act. The Bank Guarantee format for Security Deposit shall be in the prescribed formats enclosed with general conditions of contract.
- iv) Fixed Deposit Receipt issued by Scheduled Banks / Public Financial Institutions as defined in the Companies Act. The FDR should be in the name of the contractor, A/C BHEL and duly discharged on the back.



BHARAT HEAVY ELECTRICALS LIMITED

TRANSMISSION BUSINESS GROUP

(Subcontract Management)

PLOT NO.- 25, SECTOR-16A, NOIDA-201301

Tender Spec. no.: TBSM/VATAMAN & HALVAD/SI/TENDER/23-24, Date: 02.04.2024

- v) Securities available from Indian Post Offices such as National Savings Certificates, Kisan Vikas Patras etc. (Certificates should be held in the name of Contractor furnishing the security and duly endorsed/hypothecated/pledged, as applicable, in favour of BHEL and duly discharged on the back).
- vi) Insurance Surety Bonds

(NOTE: BHEL will not be liable or responsible in any manner for the collection of interest or renewal of the documents or in any other matter connected therewith)

11.2 Submission of Security Deposit:

- i) At least 50 % of the required Security Deposit, shall be submitted before start of work. Balance of the Security Deposit can be submitted by way of deduction of 10% of the gross amount progressively from each running bills of the contractor till the total amount of the required Security Deposit is collected.
- ii) In case of delay in submission of performance security, enhanced performance security which would include interest (Repo rate + 4%) for the delayed period, shall be submitted by the bidder.
- iii) If the value of work done at any time exceeds the contract value, the amount of Security Deposit shall be correspondingly enhanced and the additional Security Deposit shall be immediately deposited by the Contractor or it shall be recovered from payment/s due to the Contractor.
- iv) The recoveries made from running bills (cash deduction towards balance SD amount) can be released against submission of equivalent Bank Guarantee in acceptable form, but only once, before completion of work, at the discretion of BHEL.

11.3 The BG shall be submitted only through the Banker. Along with the BG, the Bank shall also furnish a letter of confirmation

11.4 The validity of the Bank Guarantee furnished towards Security Deposit shall be up to three months more than the period of completion of work as stipulated in the LOI and the same will be kept valid by proper renewal till the completion of the work.

11.5 BHEL reserves the right of forfeiture of Security Deposit in addition to other claims and penalties in the event of the contractor's failure to fulfil any of the contractual obligations or in the event of termination of contract as per terms and conditions of the contract. BHEL reserves the right to set off the Security Deposit, against any claims of any other contracts with BHEL.



BHARAT HEAVY ELECTRICALS LIMITED

TRANSMISSION BUSINESS GROUP

(Subcontract Management)

PLOT NO.- 25, SECTOR-16A, NOIDA-201301

Tender Spec. no.: TBSM/VATAMAN & HALVAD/SI/TENDER/23-24, Date: 02.04.2024

11.6 Conditions for acceptance of bank guarantees

Contractors are advised to obtain Bank Guarantee preferably from any of the following BHEL consortium banks

Sl. No.	Name of Bank	Sl. No.	Name of Bank
1	State Bank of India	11	Punjab National Bank
2	Canara Bank	12	Union Bank of India
3	IDBI Bank Limited	13	Yes Bank Limited
4	ICICI Bank Limited	14	RBL Bank Ltd.
5	HDFC Bank Limited	15	Standard Chartered Bank
6	Axis Bank	16	Indian Overseas Bank
7	IndusInd Bank Limited	17	Kotak Mahindra Bank Limited
8	Bank of Baroda	18	Federal Bank Limited
9	Exim Bank	19	Hongkong and Shanghai Banking Corporation Ltd
10	Indian Bank		

Bank Guarantees from Banks outside BHEL's consortium shall be as below:

The Bank Guarantees of all Public sector banks can be accepted (in addition to consortium banks)

The Bank Guarantees of Co-operative banks shall not be accepted.

Bank Guarantees of other than consortium bank and public sector bank can be accepted subject to an overall exposure limit (at New Delhi) of Rs. 10 crores for banks with networth of more than Rs. 500 crores as on last balance sheet date and Rs 5 crores for banks with net worth between Rs. 350 to Rs 500 crores (A certificate and copy of latest Balance Sheet to be given by the Bank at the time of submission of Bank Guarantees).

In case of private sector banks a clause to be incorporated in the text of Bank Guarantee that it can be enforceable by being presented at any branch of the bank.

In case of foreign vendors the bank guarantees issued by foreign banks may be confirmed by our consortium bank in India.

In case of Bank Guarantees given by Non-Consortium banks (Private sector or Public sector), the Bank Guarantees are to be enforceable in New Delhi or the town/ city in which the sector office is located.



BHARAT HEAVY ELECTRICALS LIMITED

TRANSMISSION BUSINESS GROUP

(Subcontract Management)

PLOT NO.- 25, SECTOR-16A, NOIDA-201301

Tender Spec. no.: TBSM/VATAMAN & HALVAD/SI/TENDER/23-24, Date: 02.04.2024

11.7 RETURN OF SECURITY DEPOSIT:

If the contractor duly performs and completes the work in all respects to the entire satisfaction of BHEL and presents an absolute "No demand certificate", returns properties belonging to BHEL, taken, borrowed or hired by him for carrying out the said works, and furnishes performance bond BG in the prescribed proforma, Security Deposit will be released to the contractor after deducting all costs, expenses and other amounts that are to be paid to BHEL under this contract or other contracts entered into with the contractor.

It may be noted that in no case the Security Deposit shall be refunded/released prior to passing of final bill.

11.8 Bank Account Details for submission of EMD/ Security Deposit through electronic fund transfer mode.

NAME OF THE COMPANY	BHARAT HEAVY ELECTRICALS LTD
ADDRESS OF THE COMPANY	TRANSMISSION BUSINESS GROUP, PLOT NO. -25, SECTOR-16A, NOIDA DISTT.- GAUTAMBUDH NAGAR – 201301 (U.P.)
NAME OF BANK	STATE BANK OF INDIA
NAME OF BANK BRANCH	CAG-II NEW DELHI (17313)
CITY	NEW DELHI
ACCOUNT NUMBER	00000030206227732
ACCOUNT TYPE	CASH CREDIT
IFSC CODE	SBIN0017313

12.0 PAYMENT TERMS:

100% payment shall be released after completion of all activities under scope of Works, approval of all drawings/ documents, submission of all drawings/documents in required no. of sets, and submission of bill by Contractor with all required documents.

13.0 QUANTITY AND PRICE VARIATION

The quantities indicated in "Bill of Quantity" attached with the tender are indicative only and individual quantity may vary up to any extent. However, agreed unit rates shall remain firm up to a variation of $\pm 30\%$ of the total value of the rate contract irrespective of variations in the quantity of individual items.

14.0 TAXES & DUTIES: -

14.1. All taxes (except GST), duties, charges, royalties, cess and any other levies by Central/ State/local authorities for the execution of the contract shall be borne by the



BHARAT HEAVY ELECTRICALS LIMITED

TRANSMISSION BUSINESS GROUP

(Subcontract Management)

PLOT NO.- 25, SECTOR-16A, NOIDA-201301

Tender Spec. no.: TBSM/VATAMAN & HALVAD/SI/TENDER/23-24, Date: 02.04.2024

contractor and shall not be payable extra. Any increase of the same at any stage during execution of the contract shall be borne by the contractor. Quoted price of the same shall be inclusive of all such requirements.

- 14.2. Contractors have to make their own arrangement at their cost for completing the formalities, if required with relevant taxation authorities, for bringing their material, plant and machinery at site for the execution of the contract. Road permits / way bill, if required shall be arranged by the contractor.
- 14.3. The Contractor is responsible to furnish documentary evidence towards GST Registration of the State wherein the site is located or any other documents as per GST Act which may be required from time to time. BHEL will not be held to be responsible for any non-compliance of the Contractor in respect of GST laws as framed from time to time.
- 14.4. Goods and Service Tax (GST) will be reimbursed to the Contractor subject to the following conditions: -
 - i. Submission of valid GST Compliant Tax Invoice as per the GST Invoice Rules.
 - ii. The Invoice raised by the Contractor should indicate the BHEL GST Registration Number.
 - iii. Contractor declaring such invoices in GSTR-1 and the same should be available to BHEL in the form GSTR -2A/ 2B electronically through GST portal.
 - iv. Confirmation of payment of GST thereon by contractor on GST portal.
- 1.5. The GST amount shall get reflected within prescribed time limit in the GSTN for BHEL to avail the input credit. If the GST Credit is reversed/ denied/ delayed to BHEL due to non-receipt/delayed receipt of Services and/or tax invoice or due to expiry of timeline prescribed in GST law or due to any other factor for availing such Input Tax Credit (ITC) or for any other reason arising out of the act directly attributable to the Contractor, GST amount shall be recoverable from Contractor from any dues payable to the Contractor along with any interest levied/ leviable on BHEL.
- 1.6. Statutory variation, if any, on account of GST will be payable by BHEL at actuals on submission of documentary evidence.
- 1.7. TDS under Income Tax Act/ GST Act shall be deducted as per applicable rates unless Exemption certificate, if applicable, from the appropriate Authority is furnished to BHEL along with the Invoice.
- 1.8. **New Taxes & duties (Introduced after tender opening date):**

If any new tax or duty is levied by the Central/State Government/Municipality/Local Authority and becomes directly applicable on items specified in the Bill of Quantities, full reimbursement shall be made subject to submission of documentation as per statute.



BHARAT HEAVY ELECTRICALS LIMITED

TRANSMISSION BUSINESS GROUP

(Subcontract Management)

PLOT NO.- 25, SECTOR-16A, NOIDA-201301

Tender Spec. no.: TBSM/VATAMAN & HALVAD/SI/TENDER/23-24, Date: 02.04.2024

15.0 COMPLETION SCHEDULE:

All work within the scope of the work should be finished within 30 days from the issuance of the Letter of Intent (LOI).

16.0 LIQUIDATED DAMAGE/PENALTY:

In case the contractor fails to complete the project within the time specified in the tender specification or any extension thereof subject to force majeure condition, the contractor shall be liable to pay by way of LD/Penalty a sum equal to the half percent of the contract price, per calendar week or part thereof by which the commissioning of the project is delayed, subject to ceiling of 10 % of the contract price. Once the maximum limit of delay is reached (i.e. 20 week of delay) BHEL may consider termination of the contract and forfeit the Security deposit without prejudice to the other remedies under the contract.

Amended/ revised contract value (excluding ORC, Extra Works, Supplementary /Additional Items and PVC) shall be considered for calculating LD/ penalty.

17.0 VALIDITY OF OFFER

The offer shall be kept open for acceptance for a minimum period of FOUR months from the date of opening of tenders. In case BHEL calls for negotiations, such negotiations shall not amount to cancellation or withdrawal of the original offer which shall be binding on the tenderer.

18.0 DELAY AND EXTENSION OF TIME:

If, in the opinion of the Engineer, the work is delayed

- (i) by reason of civil commotion, local combination of workmen, strike or lockout, affecting any of the trades employed on the work, or
- (ii) by reason of abnormally bad weather, or
- (iii) by reason of serious loss or damage by fire, or
- (iv) by delay on the part of the agency or tradesman engaged by the BHEL in executing work not forming part of the contract, or
- (v) By reason of any other cause which in the absolute discretion of the Engineer is beyond the contractor's control, then in any such case, the Engineer (or higher authority) may make fair and reasonable extension in the completion dates of the individual items of work of the contract as whole. Such extension which will be communicated to the contractor by the Engineer in writing shall be final and binding on the contractor.
- (vi) In case of delay in completion of work BHEL reserve the right to grant time extension under the following options depending upon the performance of the vendor:



BHARAT HEAVY ELECTRICALS LIMITED

TRANSMISSION BUSINESS GROUP

(Subcontract Management)

PLOT NO.- 25, SECTOR-16A, NOIDA-201301

Tender Spec. no.: TBSM/VATAMAN & HALVAD/SI/TENDER/23-24, Date: 02.04.2024

- 18.1 Time extension without levy of LD in case it is found that delay is not attributable to the vendor.
- 18.2 Time extension with deduction of applicable LD in line with Liquidity Damage clause if the delay is solely attributable to the vendor.
- 18.3 In case facts of delay is not settled, BHEL reserve the right to grant provisional time extension for delay in completion of total work or part thereof and running/ interim payments to the vendor will be released without deduction of LD subject to submission of additional Bank guarantee equivalent to maximum LD amount valid till completion of work under their scope and grant of final time extension.
BHEL reserves to itself the following rights without entitling the Vendor for any compensation

19.0 RIGHTS OF BHEL

BHEL **reserves** the following rights in respect of this contract during the original contract period or its extensions if any, as per the provisions of the contract, without entitling the contractor for any compensation

- 19.1 To get the work done through another agency at the risk and cost of the Vendor, in the event of poor progress, or the vendor's inability to progress the work for completion as stipulated in the Contract, poor quality of work, persistent disregards of instructions of BHEL, assignment, transfer, subletting of the contracted work without written permission of BHEL, non-fulfilment of any contractual obligations etc. and to claim/recover compensation for such losses from the vendor from Security Deposit/other dues.
- 19.2 To withdraw any portion of work and/or to restrict/alter quantum of work as indicated in the contract during the progress of construction and get it done through other agency to suit BHEL's commitment to its customer or in case BHEL decides to advance the date of completion period due to other emergent reasons/BHEL's obligations to its customer.
- 19.3 To terminate the contract after due notice and forfeit Security Deposit and recover the loss sustained in getting the balance work done through other agencies in addition to liquidated damages/penalty in the events of
 - a) Vendor's continued poor progress.
 - b) Withdrawal from or abandonment of the work before completion of the work.
 - c) Corrupt or illegal act of the Vendor.
 - d) Insolvency of the Vendor.
 - e) Persistent disregard of the instructions of BHEL.
 - f) Assignment, transfer, subletting of the contract work without BHEL's written permission.
 - g) Non-fulfilment of any contractual obligations.



BHARAT HEAVY ELECTRICALS LIMITED

TRANSMISSION BUSINESS GROUP

(Subcontract Management)

PLOT NO.- 25, SECTOR-16A, NOIDA-201301

Tender Spec. no.: TBSM/VATAMAN & HALVAD/SI/TENDER/23-24, Date: 02.04.2024

- 19.4 To recover any moneys due from the Vendor, from any moneys due to the vendor under this or any other contract or from the Security Deposit.
- 19.5 To claim compensation for losses sustained in case of termination of Contract and to levy Liquidated Damage/Penalty for delay in completion of work.
- 19.6 To terminate the Contract or to restrict the quantum of work and pay only for the portion or work done in case BHEL's contract with its customer is terminated/ altered/ deferred/ disputed/ frustrated for any reasons.
- 19.7 To effect recoveries from any amounts due to the vendor under this or any other contract or in any other form the moneys which BHEL is forced to pay to anybody due to vendor's failure to fulfil any of his obligations.
- 19.8 To restrict or increase the quantity and nature of work to suit project requirements, since the tender specification is based on preliminary documents and quantities furnished therein are indicative and approximate and the rates quoted shall not be subject to revision.
- 19.9 While every endeavour will be made by BHEL to this end, BHEL cannot guarantee uninterrupted work due to conditions beyond its control. The vendor will not be entitled to any compensation/extra payment on this account. No idle charges will be payable by BHEL in any case.
- 19.10 In the event of any dispute of technical nature, the decision of BHEL shall be final and binding on the Vendor.

20.0 BREACH OF CONTRACT, REMEDIES AND TERMINATION:

In case of breach of contract, amount equivalent to 10% of contract value shall be recovered by BHEL due to breach of contract by the subcontractor.

This amount shall be recovered from security instruments like performance bank guarantee available with BHEL against the said contract

In case the value of the security instruments available is less than 10% of the contract value, the balance amount shall be recovered from other financial remedies (i.e. available bills of the contractor, retention amount, etc. with BHEL).

Further, levy of liquidated damages, debarment, termination, de-scoping, short-closure, etc., shall be applied as per provisions of the contract.



BHARAT HEAVY ELECTRICALS LIMITED

TRANSMISSION BUSINESS GROUP

(Subcontract Management)

PLOT NO.- 25, SECTOR-16A, NOIDA-201301

Tender Spec. no.: TBSM/VATAMAN & HALVAD/SI/TENDER/23-24, Date: 02.04.2024

21.0 In case of fault of the contractor, BHEL reserves the right without entitling the contractor for any compensation, To terminate the contract or withdraw portion of work and get it done through other agency after due notice of a period of 14 days' by BHEL in any of the following cases:

- i. Contractor's poor progress of the work vis-à-vis execution timeline as stipulated in the Contract, backlog attributable to contractor including unexecuted portion of work does not appear to be executable within balance available period considering its performance of execution.
- ii. Withdrawal from or abandonment of the work by contractor before completion of the work as per contract.
- iii. Non-completion of work by the Contractor within scheduled completion period as per Contract or as extended from time to time, for the reasons attributable to the contractor.
- iv. Termination of Contract on account of any other reason (s) attributable to Contractor.
- v. Assignment, transfer, subletting of Contract without BHEL's written permission.
- vi. Non-compliance to any contractual condition or any other default attributable to Contractor.

Following sequence shall be applicable for recoveries from contractor after informing the contractor of the total proposed recovery:

- i. Dues available in the form of Bills payable to contractor, SD, BGs against the same contract.
- ii. Demand notice for deposit of balance recovery amount to be sent to contractor, if funds are insufficient to effect complete recovery against dues indicated in (a) above.
- iii. If contractor fails to deposit the balance amount within the period as prescribed in demand notice, following action shall be taken for balance recovery:
- iv. Dues payable to contractor against other contracts in the same Region/unit shall be considered for recovery.



BHARAT HEAVY ELECTRICALS LIMITED

TRANSMISSION BUSINESS GROUP

(Subcontract Management)

PLOT NO.- 25, SECTOR-16A, NOIDA-201301

Tender Spec. no.: TBSM/VATAMAN & HALVAD/SI/TENDER/23-24, Date: 02.04.2024

- v. If recovery cannot be made out of dues payable to the contractor as above, balance amount to be recovered, shall be informed to other Regions/Units for making recovery from the Unpaid Bills/Running Bills/SD/BGs/Final Bills of contractor.
- vi. In-case recoveries are not possible with any of the above available options, Legal action shall be initiated for recovery against contractor.

22.0 LAW GOVERNING THE CONTRACT AND COURT JURISDICTION:

The Contract shall be governed by the Law for the time being enforced in the Republic of India. The Civil Court at Delhi having ordinary Original Civil Jurisdiction shall alone have exclusive jurisdiction in regard to all claims in respect of this contract.

23.0 FORCE MAJEURE:

The following shall amount to force majeure conditions:

- 23.1 Acts of God, Act of any Government, war, sabotage, riots, civil commotion, Police action, revolution, flood, fire cyclone, earthquake, epidemic and other similar causes over which the vendor has no control.
- 23.2 If the vendor suffers delay in the due execution of the contract, due to delays caused by force majeure conditions, as defined above, the agreed time of completion of the work covered by this contract may be extended by a reasonable period of time in consultation and after agreement of BHEL's clients/owner, provided that on the occurrence of any such contingency, the Vendor immediately reports to BHEL in writing the causes of delay. The Vendor shall not be eligible for any compensation on this account.

24.0 Model Conciliation Clause for Conducting Conciliation Proceedings Under The BHEL Conciliation Scheme, 2018

The Parties the if at any time (whether before, during or after the arbitral or judicial proceedings), any Disputes (which terms shall means and include any dispute, difference, question or disagreement arising in connection with construction, meaning, operation, effect, interpretation or breach of the agreement, contract or the Memorandum of Understanding (delete whichever is inapplicable), which the parties unable to settle mutually), arise inter-se the Parties, the same may, be referred by either party to conciliation to be conducted through Independent Experts Committee to be appointed by competent authority of BHEL from the BHEL Panel of Conciliators.

Notes:

- 1. No serving or a retired employee of BHEL/Administrative Ministry of BHEL shall be included in the BHEL Panel of Conciliators.



BHARAT HEAVY ELECTRICALS LIMITED

TRANSMISSION BUSINESS GROUP

(Subcontract Management)

PLOT NO.- 25, SECTOR-16A, NOIDA-201301

Tender Spec. no.: TBSM/VATAMAN & HALVAD/SI/TENDER/23-24, Date: 02.04.2024

2. Any other person(s) can be appointed as Conciliator(s) who is/are mutually agreeable to both the parties from outside the BHEL Panel of Conciliators.

The proceedings of Conciliation shall broadly be governed by Part-III of the Arbitration and Conciliation Act 1996 or any statutory modification thereof and as provided in Annexure-A.

The Annexure-A together with its appendices will be treated as if the same is part and parcel hereof and shall be as effectual as if set out herein in these GCC."

25.0 ARBITRATION

(i) Except as provide elsewhere in this Contract, in case amicable settlement is not reached between the Parties, in respect of any dispute or difference; arising out of the formation, breach, termination, validity or execution of the contract; or, the respective rights and liabilities of the Parties; or, in relation to interpretation of any provision of the contract; or, in relation to interpretation of any provision of the Contract; or, in any manner touching upon the contract, then, either Party may, by a notice in writing to the other Party refer such dispute or difference to the sole arbitration of an arbitrator appointed by Head of the BHEL Unit/Region/Division issuing the Contract.

The Arbitrator shall pass a reasoned award and the award of the Arbitrator shall be final and binding upon the Parties.

Subject as aforesaid, the provisions of Arbitration and Conciliation Act 1996 (India) or statutory modifications or re-enactments thereof and the rules made thereunder and for the time being in force shall apply to the arbitration proceedings under this clause.

The seat of arbitration shall be New Delhi.

The cost of arbitration shall be borne as per the award of the Arbitrator.

Subject to the arbitration in terms of clause L above, the court at New Delhi shall have exclusive jurisdiction over nay matter arising out of or in connection with this Contract.

Notwithstanding the existence or any dispute or differences and/or reference for the arbitration, the Contractor shall proceed with and continue without hindrance the performance of its obligations under this contract with due diligence and expedition in a professional manner except where the contract has been terminated by either Party in terms of this contract.

(ii) In the event of dispute or difference relating to the interpretation and application of the provisions of commercial contract(s) between Central Public Sector Enterprises (CPSEs)/ Port Trusts inter se and also between CPSEs and Government Departments/Organizations (excluding disputes concerning Railways, Income Tax, Customs & Excise Departments), such dispute or difference shall be taken up by either party for resolution through AMRCD as mentioned in DPE OM No.4(1)/2013-DPE9GM)/FTS-1835 dated 22.05.2018.



BHARAT HEAVY ELECTRICALS LIMITED

TRANSMISSION BUSINESS GROUP

(Subcontract Management)

PLOT NO.- 25, SECTOR-16A, NOIDA-201301

Tender Spec. no.: TBSM/VATAMAN & HALVAD/SI/TENDER/23-24, Date: 02.04.2024

26.0 Provisions for micro and small enterprises (MSEs)

Any bidder falling under MSE category shall furnish the following details & submit documentary evidence / Govt. Certificate etc. in support of the same along with their techno-commercial offer.

Type under MSE	
Micro	
Small	

Note: If the bidder does not furnish the above, offer shall be processed construing that the bidder is not falling under MSE category.

- a) MSE vendors can avail the intended benefits only if they submit along with the offer, attested copies of either EM II certificate having deemed validity (five years from the date of issue of acknowledgement in EM II) or valid NSIC certificate or UDYAM REGISTRATION CERTIFICATE or EM II certificate along with attested copy of a CA certificate (Format enclosed at Annexure -H where deemed validity of EM II certificate of five years has expired) applicable for the relevant financial year (latest audited). Date to be reckoned for determining the deemed validity will be the date of bid opening (Part 1 in case of two part bid). Non submission of such documents will lead to consideration of their bid at par with other bidders. No benefit shall be applicable for this enquiry if any deficiency in the above required documents are not submitted before price bid opening. If the tender is to be submitted through e-procurement portal, then the above required documents are to be uploaded on the portal.
- b) MSEs shall be exempted from payment of earnest money (if any) at the time of tender submission. However, there is no exemption of security deposit submission.
- c) However, credentials of all MSE suppliers will be verified before considering the intended benefits for MSE suppliers at the time of tender evaluation.

27.0 PERFORMANCE MONITORING:

The Contractors performance shall be continuously monitored during execution of work at site.

In case of contractor's performance is found not satisfactory during the execution of work at site, BHEL may take alternate remedial measures and may not consider the contractor for further tenders, if the contractor performance is not improved in spite of opportunities given by BHEL.



BHARAT HEAVY ELECTRICALS LIMITED

TRANSMISSION BUSINESS GROUP

(Subcontract Management)

PLOT NO.- 25, SECTOR-16A, NOIDA-201301

Tender Spec. no.: TBSM/VATAMAN & HALVAD/SI/TENDER/23-24, Date: 02.04.2024

PROFORMA OF BANK GUARANTEE (in lieu of SECURITY DEPOSIT)

In consideration of Bharat Heavy Electricals Limited (hereinafter referred to as the 'Employer' which expression shall unless repugnant to the context or meaning thereof, include its successors and permitted assigns) incorporated under the Companies Act, 1956 and having its registered office at BHEL House, Siri Fort, New Delhi-110049 through its Unit at BHEL, Transmission Business Group, Noida (name of the Unit) having agreed to exempt _____ (Name of the Vendor / Contractor / Supplier) with its registered office at _____¹ (hereinafter called the said "Contractor" which term includes supplier), from demand under the terms and conditions of the Contract reference No. _____ dated _____² valued at Rs.....³ (Rupees) (hereinafter called the said Contract), of Security Deposit for the due fulfilment by the said Contractor of the terms and conditions contained in the said Contract, on production of a Bank Guarantee for Rs.....⁴ (Rupees.....only),

We _____ (indicate the name and address of the Bank) having its Head Office at _____ (address of the head Office) (hereinafter referred to as the Bank), at the request of _____ [Contractor(s)], being the Guarantor under this Guarantee, do hereby irrevocably and unconditionally undertake to forthwith and immediately pay to the Employer, an amount not exceeding Rs. _____ without any demur, immediately on demand from the Employer and without any reservation, protest, and recourse and without the Employer needing to prove or demonstrate reasons for its such demand

Any such demand made on the bank, shall be conclusive as regards the amount due and payable by the Bank under this guarantee. However, our liability under this guarantee shall be restricted to an amount not exceeding Rs. _____.

We undertake to pay to the Employer any money so demanded notwithstanding any dispute or disputes raised by the Contractor(s) in any suit or proceeding pending before any Court or Tribunal or Arbitrator or any other authority, our liability under this present being absolute and unequivocal.

The payment so made by us under this guarantee shall be a valid discharge of our liability for payment hereunder and the Contractor(s) shall have no claim against us for making such payment. We, further agree that the guarantee herein contained shall remain in full force and effect during the period that would be taken for the performance of the said Contract and that it shall continue to be enforceable till all the dues of the Employer under or by virtue of the said Contract have been fully paid and its claims satisfied & the Employer certifies that the terms and conditions of the said Contract have been fully and properly carried out by the said contractor(s) or acceptance of the final bill or discharge of this guarantee by the Employer, whichever is earlier. This guarantee shall initially remain in force up to and including _____⁵ and shall be extended from time to time for such period as may be desired by the Employer. Unless a demand or claim under this guarantee is made on us in writing on or before the _____⁶, (3 months more than the present date of validity of Bank Guarantee) we shall be discharged from all the liability under this guarantee thereafter.



BHARAT HEAVY ELECTRICALS LIMITED

TRANSMISSION BUSINESS GROUP

(Subcontract Management)

PLOT NO.- 25, SECTOR-16A, NOIDA-201301

Tender Spec. no.: TBSM/VATAMAN & HALVAD/SI/TENDER/23-24, Date: 02.04.2024

We, _____ (indicate the name of the Bank) further agree with the Employer that the Employer shall have the fullest liberty without our consent and without affecting in any manner our obligations hereunder to vary any of the terms and conditions of the said Contract or to extend time of performance by the said contractor(s) from time to time or to postpone for any time or from time to time any of the powers exercisable by the Employer against the said contractor(s) and to forbear or enforce any of the terms and conditions relating to the said Contract and we shall not be relieved from our liability by any reason of any such variation or extension being granted to the said contractor(s) or for any forbearance, act or omission on the part of the Employer or any indulgence by the Employer to the said contractor(s) or by any such matter or thing whatsoever which under the law relating to sureties would but for this provision have effect of so relieving us.

The Bank also agrees that the Employer at its option shall be entitled to enforce this Guarantee against the Bank as a principal debtor, in the first instance without proceeding against the Contractor and notwithstanding any security or other guarantee that the Employer may have in relation to the Contractor's liabilities.

This Guarantee shall not be determined or affected by liquidation or winding up, dissolution or change of constitution or insolvency of the Contractor but shall in all respects and for all purposes be binding and operative until payment of all money payable to the Employer in terms thereof. This guarantee will not be discharged due to the change in the constitution of the Bank or the Contractor(s).

We,..... BANK lastly undertake not to revoke this guarantee during its currency except with the previous consent of the Employer in writing.

Notwithstanding anything to the contrary contained hereinabove:

- a) The liability of the Bank under this Guarantee shall not exceed.....⁴
- b) This Guarantee shall be valid up to⁵
- c) Unless the Bank is served a written claim or demand on or before _____⁶ all rights under this guarantee shall be forfeited and the Bank shall be relieved and discharged from all liabilities under this guarantee irrespective of whether or not the original bank guarantee is returned to the Bank.

We, _____ Bank, have power to issue this Guarantee under law and the undersigned as a duly authorized person has full powers to sign this Guarantee on behalf of the Bank.

Date _____ Day of _____
for _____(indicate the name of the Bank)_____
(Signature of Authorised signatory)

¹ ADDRESS OF THE VENDOR /CONTRACTOR / SUPPLIER .
² DETAILS ABOUTTHE NOTICE OF AWARD/CONTRACTREFERENCE
³ CONTRACT VALUE
⁴ BG AMOUNTIN FIGURES AND WORDS
⁵ VALIDITY DATE (At least 3 months more than completion period)



BHARAT HEAVY ELECTRICALS LIMITED

TRANSMISSION BUSINESS GROUP

(Subcontract Management)

PLOT NO.- 25, SECTOR-16A, NOIDA-201301

Tender Spec. no.: TBSM/VATAMAN & HALVAD/SI/TENDER/23-24, Date: 02.04.2024

⁶ DATE OF EXPIRY OF CLAIM PERIOD (At least 3 months more than the present date of validity of BG)

Notes:

- 1 The expiry of claim period shall be at least 3 months more than the validity date. It may be ensured that the same is in line with the agreement/ contract entered with the Vendor.
- 2 The BG should be on Non-Judicial Stamp paper/e-stamp paper of appropriate value as per Stamp Act prevailing in the State(s) where the BG is submitted or is to be acted upon or the rate prevailing in the State where the BG was executed, whichever is higher. The Stamp Paper/e-stamp paper shall be purchased in the name of Vendor/Contractor/Supplier /Bank issuing the guarantee.

3 In Case of Bank Guarantees submitted by Foreign Vendors:

- a. **From Nationalized/Public Sector / Private Sector/ Foreign Banks (BG issued by Branches in India)** can be accepted subject to the condition that the Bank Guarantee should be enforceable in the town/city or at nearest branch where the Unit is located i.e. Demand can be presented at the Branch located in the town/city or at nearest branch where the Unit is located.
- b. **From Foreign Banks (wherein Foreign Vendors intend to provide BG from local branch of the Vendor country's Bank)**
 - b.1 In such cases, in the Tender Enquiry/ Contract itself, it may be clearly specified that Bank Guarantee issued by **any of the Consortium Banks only** will be accepted by BHEL. As such, Foreign Vendor needs to make necessary arrangements for issuance of Counter- Guarantee by Foreign Bank in favour of the Indian Bank's (BHEL's Consortium Bank) branch in India. It is advisable that all charges for issuance of Bank Guarantee/ counter- Guarantee should be borne by the Foreign Vendor. The tender stipulation should clearly specify these requirements.
 - b.2 In case, Foreign Vendors intend to provide BG from Overseas Branch of our Consortium Bank (e.g. if a BG is to be issued by SBI Frankfurt), the same is acceptable. However, the procedure at sl.no. b.1 will required to be followed.

ANNEXURE TO MODEL CONCILIATION CLAUSE FOR CONDUCT OF CONCILIATION UNDER THE BHEL CONCILIATION SCHEME, 2018

BRIEF PROCEDURE FOR CONDUCT OF CONCILIATION PROCEEDINGS

1. The proceedings of Conciliation shall broadly be governed by Part-III of the Arbitration and Conciliation Act 1996 or any statutory modification thereof and as provided herein:
2. The party desirous of resorting to Conciliation shall send an invitation/notice in writing to the other party to conciliate specifying all points of Disputes with details of the amount claimed. The party concerned shall not raise any new issue thereafter. Parties shall also not claim any interest on claims/counter-claims from the date of notice invoking Conciliation till the conclusion of the Conciliation proceedings.
3. The party receiving the invitation/notice for Conciliation shall within 30 days of receipt of the notice of Conciliation intimate its consent for Conciliation along with its counter-claims, if any.
4. The Conciliation in a matter involving claim or counter-claim (whichever is higher) up to Rs 5 crores shall be carried out by sole Conciliator nominated by BHEL while in a matter involving claim or counter-claim (whichever is higher) of more than Rs 5 crores Conciliation shall be carried out by 3 Conciliators nominated by BHEL.
5. The Parties shall be represented by only their duly authorized in-house executives/officers and neither Party shall be represented by a Lawyer.
6. The first meeting of the IEC shall be convened by the IEC by sending appropriate communication/notice to both the parties as soon as possible but not later than 30 days from the date of his/their appointment. The hearings in the Conciliation proceeding shall ordinarily be concluded within two (2) months and, in exceptional cases where parties have expressed willingness to settle the matter or there exists possibility of settlement in the matter, the proceedings may be extended by the IEC by a maximum of further 2 months with the consent of the Parties subject to cogent reasons being recorded in writing.
7. The IEC shall thereafter formulate recommendations for settlement of the Disputes supported by reasons at the earliest but in any case within

15 days from the date of conclusion of the last hearing. The recommendations so formulated along with the reasons shall be furnished by the IEC to both the Parties at the earliest but in any case within 1 month from the date of conclusion of the last hearing.

8. Response/modifications/suggestions of the Parties on the recommendations of the IEC are to be submitted to the IEC within time limit stipulated by the IEC but not more than 15 days from the date of receipt of the recommendations from the IEC.
9. In the event, upon consideration, further review of the recommendations is considered necessary, whether by BHEL or by the other Party, then, the matter can be remitted back to the IEC with request to reconsider the same in light of the issues projected by either/both the Parties and to submit its recommendations thereon within the following 15 days from the date of remitting of the case by either of the Parties.
10. Upon the recommendations by the Parties, with or without modifications, as considered necessary, the IEC shall be called upon to draw up the Draft Settlement Agreement in terms of the recommendations.
11. When a consensus can be arrived at between the parties only in regard to any one or some of the issues referred for Conciliation the draft Settlement Agreement shall be accordingly formulated in regard to the said Issue(s), and the said Settlement Agreement, if signed, by the parties, shall be valid only for the said issues. As regards the balance issues not settled, the parties may seek to resolve them further as per terms and conditions provided in the contract.
12. In case no settlement can be reached between the parties, the IEC shall by a written declaration, pronounce that the Conciliation between the parties has failed and is accordingly terminated.
13. Unless the Conciliation proceedings are terminated in terms of para 22 (b), (c) & (d) herein below, the IEC shall forward his/its recommendations as to possible terms of settlement within one (1) month from the date of last hearing. The date of first hearing of Conciliation shall be the starting date for calculating the period of 2 months.

14. In case of 3 members IEC, 2 members of IEC present will constitute a valid quorum for IEC and meeting can take place to proceed in the matter after seeking consent from the member who is not available. If necessary, videoconferencing may be arranged for facilitating participation of the members. However, the IEC recommendations will be signed by all members. Where there is more than one (1) Conciliator, as a general rule they shall act jointly. In the event of differences between the Members of IEC, the decision/recommendations of the majority of the Members of IEC shall prevail and be construed as the recommendation of the IEC.
15. The Draft Settlement Agreement prepared by the IEC in terms of the consensus arrived at during the Conciliation proceedings between the Parties shall be given by the IEC to both the parties for putting up for approval of their respective Competent Authority.
16. Before submitting the draft settlement agreement to BHEL's Competent Authority viz. the Board Level Committee on Alternative Dispute Resolution (BLCADR) for approval, concurrence of the other party's Competent Authority to the draft settlement agreement shall be obtained by the other party and informed to BHEL within 15 days of receipt of the final draft settlement agreement by it. Upon approval by the Competent Authority, the Settlement Agreement would thereafter be signed by the authorized representatives of both the Parties and authenticated by the members of the IEC.
17. In case the Draft Settlement Agreement is rejected by the Competent Authority of BHEL or the other Party, the Conciliation proceedings would stand terminated.
18. A Settlement Agreement shall contain a statement to the effect that each of the person(s) signing thereto (i) is fully authorized by the respective Party(ies) he/she represents, (ii) has fully understood the contents of the same and (iii) is signing on the same out of complete freewill and consent, without any pressure, undue influence.
19. The Settlement Agreement shall thereafter have the same legal status and effect as an arbitration award on agreed terms on the substance of the dispute rendered by an arbitral tribunal passed under section 30 of the Arbitration and Conciliation Act, 1996.
20. Acceptance of the Draft Settlement Agreement/recommendations of the Conciliator and/or signing of the Settlement Agreement by BHEL shall

however, be subject to withdrawal/closure of any arbitral and/or judicial proceedings initiated by the concerned Party in regard to such settled issues.

21. Unless otherwise provided for in the agreement, contract or the Memorandum of Understanding, as the case may be, in the event of likelihood of prolonged absence of the Conciliator or any member of IEC, for any reason/incapacity, the Competent Authority/Head of Unit/Division/Region/Business Group of BHEL may substitute the Conciliator or such member at any stage of the proceedings. Upon appointment of the substitute Conciliator(s), such reconstituted IEC may, with the consent of the Parties, proceed with further Conciliation into the matter either de-novo or from the stage already reached by the previous IEC before the substitution.

22. The proceedings of Conciliation under this Scheme may be terminated as follows:

- a. On the date of signing of the Settlement agreement by the Parties; or,
- b. By a written declaration of the IEC, after consultation with the parties, to the effect that further efforts at conciliation are no longer justified, on the date of the declaration; or,
- c. By a written declaration of the Parties addressed to the IEC to the effect that the Conciliation proceedings are terminated, on the date of the declaration; or,
- d. By a written declaration of a Party to the other Party and the IEC, if appointed, to the effect that the Conciliation proceedings are terminated, on the date of the declaration.
- e. On rejection of the Draft Settlement Agreement by the Competent Authority of BHEL or the other Party.

23. The Conciliator(s) shall be entitled to following fees and facilities:

Sl No	Particulars	Amount
1	Sitting fees	Each Member shall be paid a Lump Sum fee of Rs 75,000/- for the whole case payable in terms of paragraph No. 27 herein below.
2	Towards drafting of settlement agreement	In cases involving claim and/or counter-claim of up to Rs 5crores. Rs 50,000/- (Sole Conciliator)

Sl No	Particulars	Amount
		<p>In cases involving claim and/or counter-claim of exceeding Rs 5 crores but less than Rs 10 crores. Rs 75,000 (per Conciliator)</p> <p>In cases involving claim and/or counter-claim of more than Rs 10 crores. Rs 1,00,000/- (per Conciliator)</p> <p>Note: The aforesaid fees for the drafting of the Settlement Agreement shall be paid on Signing of the Settlement Agreement after approval of the Competent Authority or Rejection of the proposed Settlement Agreement by the Competent Authority of BHEL.</p>
3	Secretarial expenses	<p>Rs 10,000/- (one time) for the whole case for Conciliation by a Sole Member IEC.</p> <p>Where Conciliation is by multi member Conciliators –Rs 30,000/- (one time)- to be paid to the IEC</p>
4	<p>Travel and transportation and stay at outstation</p> <p>i) Retired Senior Officials of other Public Sector Undertakings (pay scale wise equivalent to or more than E-8 level of BHEL)</p>	<p>As per entitlement of the equivalent officer (pay scale wise) in BHEL.</p>
	Others	<p>As per the extant entitlement of whole time Functional Directors in BHEL.</p>

Sl No	Particulars	Amount
		Ordinarily, the IEC Member(s) would be entitled to travel by air Economy Class.
5	Venue for meeting	Unless otherwise agreed in the agreement, contract or the Memorandum of Understanding, as the case may be, the venue/seat of proceedings shall be the location of the concerned Unit / Division / Region / Business Group of BHEL. Without prejudice to the seat/venue of the Conciliation being at the location of concerned BHEL Unit / Division / Region / Business Group, the IEC after consulting the Parties may decide to hold the proceedings at any other place/venue to facilitate the proceedings. Unless, Parties agree to conduct Conciliation at BHEL premises, the venue is to be arranged by either Party alternately.

24. The parties will bear their own costs including cost of presenting their cases/evidence/witness(es)/expert(s) on their behalf. The parties agree to rely upon documentary evidence in support of their claims and not to bring any oral evidence in IEC proceedings.
25. If any witness(es) or expert(s) is/are, with the consent of the parties, called upon to appear at the instance of the IEC in connection with the matter, then, the costs towards such witness(es)/expert(s) shall be determined by the IEC with the consent of the Parties and the cost so determined shall be borne equally by the Parties.
26. The other expenditures/costs in connection with the Conciliation proceedings as well as the IEC's fees and expenses shall be shared by the Parties equally.
27. Out of the lump sum fees of Rs 75,000/- for Sitting Fees, 50% shall be payable after the first meeting of the IEC and the remaining 50% of the Sitting Fees shall be payable only after termination of the conciliation proceedings in terms of para 22 hereinabove.

28. The travelling, transportation and stay at outstation shall be arranged by concerned Unit as per entitlements as per Serial No. 3 of the Table at para 23 above, and in case such arrangements are not made by the BHEL Unit, the same shall be reimbursed to the IEC on actuals limited to their entitlement as per Serial No. 4 of the Table at Para 23 above against supporting documents. The IEC Member(s) shall submit necessary invoice for claiming the fees/reimbursements.
29. The Parties shall keep confidential all matters relating to the conciliation proceedings. Confidentiality shall extend also to the settlement agreement, except where its disclosure is necessary for purposes of its implementation and enforcement or as required by or under a law or as per directions of a Court/Governmental authority/regulatory body, as the case may be.
30. The Parties shall not rely upon or introduce as evidence in any further arbitral or judicial proceedings, whether or not such proceedings relate to the Disputes that is the subject of the Conciliation proceedings:
 - a. Views expressed or suggestions made by the other party in respect of a possible settlement of the Disputes;
 - b. admissions made by the other party in the course of the Conciliator proceedings;
 - c. proposals made by the Conciliator;
 - d. The fact that the other Party had indicated his willingness to accept a proposal for settlement made by the Conciliator.
31. The Parties shall not present the Conciliator(s) as witness in any Alternative Dispute Resolution or Judicial proceedings in respect of a Disputes that is/was the subject of that particular Conciliation proceeding.
32. None of the Conciliators shall act as an arbitrator or as a representative or counsel of a Party in any arbitral or judicial proceeding in respect of a Disputes that is/was the subject of that particular Conciliation proceeding.
33. The Parties shall not initiate, during the Conciliation proceedings, any arbitral or judicial proceedings in respect of a Disputes that is the subject matter of the Conciliation proceedings except that a Party may initiate arbitral or judicial proceedings where, in his opinion, such proceedings are necessary for preserving his rights including for preventing expiry of period of limitation. Unless terminated as per the provisions of this Scheme, the Conciliation proceedings shall continue

notwithstanding the commencement of the arbitral or judicial proceedings and the arbitral or judicial proceedings shall be primarily for the purpose of preserving rights including preventing expiry of period of limitation.

34. The official language of Conciliation proceedings under this Scheme shall be English unless the Parties agree to some other language.

Format 2 to BHEL Conciliation Scheme, 2018

**FORMAT FOR SEEKING CONSENT FOR REFERRING THE DISPUTES TO
CONCILIATION THROUGH IEC**

To,

M/s. (Stakeholder's name)

**Sub: Resolution of the Disputes through conciliation by Independent
Expert Committee (IEC).**

Ref: Contract No/MoU/Agreement/LOI/LOA& date _____.

Sir,

With reference to above referred Contract/MoU/Agreement/LOI/LOA, you have raised certain Disputes/claims. Vide your letter dated_____ you have requested BHEL to refer the Disputes/claims to IEC for Conciliation.

We are enclosing herewith Format (3) for giving consent and the terms and conditions of BHEL Conciliation Scheme, 2018 governing conciliation through IEC. You are requested to give your unconditional consent to the said terms and conditions of the Scheme by returning the same duly sealed and signed on each page. On receipt of your consent, matter will be put to the Competent Authority for consideration and decision.

Please note that BHEL has also certain claims against you (if applicable). BHEL reserves its right to agree or not to agree conciliation of the said disputes through BHEL and this letter is being issued without prejudice to BHEL's rights and contentions available under the contract and law.

Yours faithfully,

Representative of BHEL

Format 3 to BHEL Conciliation Scheme, 2018
FORMAT FOR GIVING CONSENT BY
CONTRACTOR/VENDOR/CUSTOMER/COLLABORATOR/CONSORTIUM PARTNERS FOR REFERRING THE DISPUTES TO CONCILIATION THROUGH IEC

To,

BHEL

.....

Sub: Resolution of Disputes through Conciliation by Independent Expert Committee (IEC).

Ref: Contract/MoU/Agreement/LOI/LOA No & date____

With reference to above referred contract, our following bills/invoices/claims submitted to BHEL are still unpaid giving rise to Disputes:

SL. no.	Claim Description	Bill submitted to BHEL (no. and date)	Amount of the bill/claim	Amount received from BHEL	Outstanding Amount

Accordingly we request you to kindly refer the Disputes in respect of above claims to IEC for Conciliation.

We hereby agree and give our unconditional consent to the terms and conditions of BHEL Conciliation Scheme, 2018 governing conciliation through IEC. We have signed the same on each page and enclosed it for your consideration.

Yours faithfully,

(Signature with stamp)

Authorized Representative of Contractor

Name, with designation

Date

Format 5 to BHEL Conciliation Scheme, 2018
STATEMENT OF CLAIMS/COUNTER CLAIMS TO BE SUBMITTED TO
THE IEC BY BOTH THE PARTIES

1. Chronology of the Disputes
2. Brief of the Contract/MoU/Agreement/LOI/LOA
3. Brief history of the Disputes:
4. Issues:
5. Details of Clam(s)/Counter Claim(s):

SI. No.	Description of claim(s)/Counter Claim	Amount (in INR)Or currency applicable in the contract	Relevant contract clause

6. Basis/Ground of claim(s)/counter claim(s) (along with relevant clause of contract)

Note– *The Statement of Claims/Counter Claims may ideally be restricted to maximum limit of 20 pages. Relevant documents may be compiled and submitted along with the statement of Claims/Counter Claims. The statement of Claims/Counter Claims is to be submitted to all IEC members and to the other party by post as well as by email.*

BILL OF QUANTITIES CUM PRICE SCHEDULE (ANNEXURE-I)

Project : 765/400/220kV Sub-Station, Vataman(New) and 765kV S/S Halvad

Name of Work: SOIL INVESTIGATION & TOPOGRAPHY SURVEY WORK AT 765/400/220KV AT VATAMAN (NEW) & EXTENSION OF 765 KV S/S AT HALVAD IN GUJARAT

Tender Spec. No.: TBSM/VATAMAN & HALVAD/SI/TENDER/23-24, Date: 02.04.2024

Sr. No.	Description of Item	Quantity		Total Quantity	UOM	Unit Rate	Amount
		Vataman	Halvad				
PART-A SOIL INVESTIGATION WORK							
1	Mobilization & Demobilisation of necessary equipment, tools, plants, manpower, etc., for conducting soil investigation at a project site. (Payment against this item shall be made for the oneway distance of the project site (Vataman) from the registered office of the bidder. Relevant document for the proof of distance shall be furnished with the claim.) Note: No separate payment shall be made for Mobilization/Demobilisation for Halvad site.	1500		1500	KM	₹ 36.55	₹ 54,825.78
2	Drilling boreholes of 150mm dia in accordance with the provision of IS:1892 at specified locations upto 15mtr depth into virgin soil or refusal whichever occurs earlier including performing SPT, collecting disturbed and undisturbed samples, recording watertable etc., all complete as per specification including backfilling of boreholes as per direction of Engineer-In-Charge.	300	30	330	RM	₹ 548.26	₹ 1,80,925.07
2 (b)	Add extra for rock drilling in boreholes where rock is encountered, all complete as per specification and direction of Engineer-In-Charge.	5	5	10	RM	₹ 2,253.95	₹ 22,539.52
2 (c)	Add extra for drilling boreholes beyond 15m depth.	5	5	10	RM	₹ 1,583.85	₹ 15,838.53
3	Making trial pits of 2 m x 2 m in size extending to 4 m depths or as specified by customer at specified locations and taking undisturbed samples as per specification including backfilling of pit as per direction of Engineer-In-Charge	8	2	10	Nos	₹ 2,558.54	₹ 25,585.36
4	Conducting plate load test at specified location (loading intensity upto 8kg/cm ² or 40mm settlement whichever occurs earlier) all complete as per specification using plate of following size including backfilling as per direction of Engineer-In-Charge: 450mm X 450mm/ 600mm X 600mm	2	-	2	Nos	₹ 29,240.42	₹ 58,480.83
5	Conducting Field California Bearing Ratio tests at specified locations complete as per specification including backfilling as per direction of Engineer-In-Charge.	4	-	4	Nos	₹ 3,655.05	₹ 14,620.21
6	Conducting laboratory tests on soil and water samples all complete as per customer specification clause No. 2.8 "LABORATORY TEST". (Payment against this item shall be made based on the total no. of boreholes driven as per Item No.2(a) however, charges for Laboratory testing of the samples collected from trial pits/plate load test pits shall be deemed to be inclusive in this item.). Note: The Laboratory tests shall be carried out at any Govt approved Engineering college/NIT/ NABL accredited laboratories.	20	2	22	Per Bore-hole	₹ 1,583.85	₹ 34,844.76
7	Conducting Electrical resistivity test(ERT) as per specification including all necessary arrangement required to conducting the test as per customer Technical Specification.	64	24	88	Nos	₹ 1,766.61	₹ 1,55,461.28
8	Furnishing Soft copy of draft report for BHEL/Customer Comment and 5 copies of Signed final report in Hard Copy.	1	1	2	Lot	₹ 7,310.10	₹ 14,620.21
PART-B TOPOGRAPHY SURVEY WORK							
1	Detailed topographical survey of entire substation land, construction of bench marks, transfer of the reduced levels & coordinates to the bench marks (As per Enclosed Drawing), preparation of survey report, survey map & contour plan, all complete as per mentioned scope of work including cost of mobilization & demobilization, manpower, tools & tackles, equipment, etc. as per direction of Engineer-In-Charge.	225000	33750	258750	Sqm	₹ 0.24	₹ 61,473.41
2	Furnishing Survey Map in AUTOCAD as well as Excel Sheet showing Reduced level at grid of 5m x 5m, Hard copies of survey map, optimum quantity of Earthwork in cutting & filling with proposed F.G.L and Survey Report as mentioned in the Clause 1.4.0 (Soft Excel copy of draft report / drawing for BHEL /Customer review & Four copies of Signed final report/ drawings) and as per direction of Engineer-In-Charge.	1	1	2	Lot	₹ 9,137.63	₹ 18,275.26
TOTAL AMOUNT(PART A + PART B) (Rs.)- Excluding GST							₹ 6,57,490

Validate

Print

Help

Percentage BoQ

Tender Inviting Authority: BHEL, TBG- SubContracting Department, Sector 16A Noida, UP

Name of Work: TENDER FOR "SOIL INVESTIGATION & TOPOGRAPHY SURVEY WORK AT 765/400/220KV AT VATAMAN (NEW) & EXTENSION OF 765 KV S/S AT HALVAD IN GUJARAT"

Contract No: TBSM/VATAMAN & HALVAD/SI/TENDER/23-24 DATE 02.04.2024

Name of the Bidder/ Bidding Firm / Company :						
PRICE SCHEDULE						
(This BOQ template must not be modified/replaced by the bidder and the same should be uploaded after filling the relevant columns, else the bidder is liable to be rejected for this tender. Bidders are allowed to enter the Bidder Name and Values only)						
NUMBER #	TEXT #	NUMBER #	TEXT #	NUMBER	NUMBER #	TEXT #
Sl. No.	Item Description	Quantity	Units	Estimated Rate in Rs. P	TOTAL AMOUNT Without Taxes in Rs. P	TOTAL AMOUNT In Words
1	2	4	5	6	53	55
1	Total amount as per rates in BOQ (as per Annexure-I) for "SOIL INVESTIGATION & TOPOGRAPHY SURVEY WORK AT 765/400/220KV AT VATAMAN (NEW) & EXTENSION OF 765 KV S/S AT HALVAD IN GUJARAT."- Excluding GST	1.000	Nos	657490.00	657490.00	INR Six Lakh Fifty Seven Thousand Four Hundred & Ninety Only
Total in Figures					657490.00	INR Six Lakh Fifty Seven Thousand Four Hundred & Ninety Only
Quoted Rate in Figures			Select		0.000	INR Zero Only
Quoted Rate in Words		INR Zero Only				

SECTION -1

SCOPE, SPECIFIC TECHNICAL REQUIREMENT AND SCHEDULE OF ITEMS

1.1.0 SCOPE

1.1.1 The scope of work under this specification is to carry out detailed Geotechnical investigation test, Electrical resistivity & Topographical survey with contours required for construction of 765/400/220 kV substation at Vataman (New) & extension of 765 kV S/s at Halvad in Gujarat. The customer is Powergrid Corporation of India Ltd (PGCIL).

1.1.2 **SOIL INVESTIGATION & EARTH RESISTIVITY:** The Soil Investigation along with Soil Resistivity Measurement of the substation shall generally include the followings:-

- (i) The work shall include mobilization of necessary equipment, providing necessary engineering supervision and technical personnel, skilled and unskilled labour, etc. as required to carry out the entire field work as well as laboratory investigation.
- (ii) Carrying out geotechnical investigation and electrical resistivity test.
- (iii) Analysis and interpretation of data collected and preparation of a detailed soil report including specific recommendations for the type of foundations and the safe bearing capacity for different sizes of foundations at different founding levels for the various structures of the substation.
- (iv) All the field & laboratory data shall be recorded in the proformas recommended in IS Codes/Customer approved protocols.
- (v) All work shall be carried out as per Customer Technical Specification.
- (vi) The Bidder shall make his own arrangement for locating the coordinates and various test positions in the field (including clearance of the site at the location of test positions, if necessary) all as per the information supplied to him. The test locations shall be furnished during execution of work.
- (vii) The Bidder shall make his own arrangement for water and electricity (if required) and arrangement for putting up his man & material.
- (viii) Grass cutting/Jungle cleaning required for carrying out soil investigation work shall deemed to be included in the bidder scope.
- (ix) Bidder must visit the site before quoting the rate to have fare idea of site. Drawing & locations of bore-holes / test points shall be provided to the successful bidder. Some test locations may be finalized at the site after successful award of the contract during detail engineering.
- (x) **In case of anything mentioned in customer technical specification is at variance with standard technical specification/ IS code mentioned herein, the provision of customer technical specification shall prevail.**
- (xi) All laboratory test shall be carried out in customer approved Test lab/NABL accredited Test lab.
- (xii) All Geotechnical investigation reports must be signed and stamped by qualified Geotechnical Engineer/Consultant even if they have been prepared by NABL accredited test labs.

- (xiii) After collection of sample from bore holes, trial pits, plate load test, etc. shall be backfilled as per direction of Engineer-In-Charge.
- (xiv) Any other work required to complete above work.

1.1.3

TOPOGRAPHY SURVEY: The Topographical Survey of the substation shall generally include the followings:-

- (i) Surveying of the substation land boundary with co-ordinates of each corner points and dimension of each side by total station / GPS. Marking of locations of any permanent structure near the boundary.
- (ii) Surveying of total area of the substation land with contours.
- (iii) Verification of Input data/Existing data provided by BHEL/Customer or collection of data from any agency.
- (iv) A grid system of co-ordinates shall be established so that grid line will be parallel to the boundary of Sub-Station.
- (v) 5m x 5m grids shall be considered for spot level and at closer distances wherever pits, undulations, etc. are met. Suitable contour interval as instructed by Engineer-in-charge based on the ground profile shall be followed for contour maps.
- (vi) Preparation of the drawing in AUTOCAD showing:
 - a) All natural features like ditches and water bodies.
 - b) All botanicals feature like trees, truncated tree.
 - c) All man made features like existing buildings, pump house, canal, road, overhead electric lines, electric towers, electrical pylons, wells, pipe line, height of electric wire, and all other permanent structures.
- (vii) The Bidder shall make his own arrangement for locating the coordinates in the field (including clearance of site at the location of test positions, if necessary) all as per the information supplied to him and also for determining the reduced levels of these locations from nearby Rail Gate/ National Highway Authority of India (Collection of data from NHAI is in the scope of Bidder).
- (viii) Masonry pillars shall be erected (Drawing enclosed) at suitable places in the area to serve as bench mark for the execution of work. These bench mark shall be connected with G.T.S of any other permanent Bench mark approved by the Engineer-In-Charge. Minimum 06 bench marks and adequate number of grid pillar as per direction of Engineer-In-Charge shall be constructed in isolation area adjacent to substation area as per directions of engineer-in-charge. The reduced levels & coordinates shall be clearly marked on the bench marks.
- (ix) All the field data shall be recorded in the proforma recommended in IS Codes /CPWD/Good Standard Practices/Customer approved Field Books dually signed by Engineer-In-Charge.
- (x) Bidder should calculate the optimum quantity of Earthwork in cutting and filling using spot level method with proposed Finished Ground Level. FGL (Finished Ground Level) shall be proposed by bidder considering HFL (High Flood level), Highway passing near by the site to avoid water logging in the proposed site in future.
- (xi) The work shall include mobilization of necessary equipment, providing necessary engineering supervision and technical personnel, skilled and unskilled labour, etc. as required to carry out the entire field work.

(xii) The Bidder shall make his own arrangement for water and electricity (if required) and arrangement for putting up his man & material.

(xiii) **Grass cutting/Jungle cleaning required for carrying out survey work, Bench mark work etc. shall deemed to be included in the bidder scope.**

(xiv) Bidder must visit the site before quoting the rate to have fare idea of site.

(xv) Any other work required to complete above work.

1.2.0 SPECIFIC TECHNICAL REQUIREMENT

1.2.1 The specific technical requirements for the execution of Geotechnical Investigation, Soil Resistivity Measurement & Topographical survey with contours shall be as per Standard Specification / I.S. Codes/ CPWD Specification / Customer Specification / good standard of practices necessary to fulfil the objective.

1.2.2 In the evaluation of earth resistivity for the substations, at least eight test directions shall be chosen from the centre of the substation to cover the entire area including the future area. Electrical measurements of the subsoil at various depths up to 20 meters shall be made at the site of each substation in order to determine the layered effects of the ground from which the effective ground resistivity and hence the expected resistance of the proposed earth grid system may be predicted.

1.2.3 Soil resistivity measurement may be done in dry season. Small amount of water may be applied at electrodes for making proper contact between the electrodes and soil.

1.3.0 BILL OF QUANTITIES

1.3.1 The Bill of Quantity cum price schedule shall be as per page 5 to page 6.

1.3.2 The quantities indicated in the 'Bill of Quantity cum price schedule' are indicative and can vary upto any extent, even may get deleted. Contractor shall not be entitled for any claim for any such variation in the quantities.

1.3.3 The provision of Bill of Quantity cum price schedule, specifications and drawings shall be read in conjunction with each other and in case of conflict amongst them, the clarification shall be obtained from the Engineer-in-charge whose decision shall be final and binding.

1.3.4 No extra work shall be carried out without prior approval in soil resistivity measurement and geotechnical investigation.

1.4.0 DOCUMENT SUBMISSION

1.4.1 The contractor shall submit complete soil investigation report consisting of information regarding the geological detail of the site, summarized observations, bore-log details, test data & reports, earth resistivity measurement reports, ground water level, conclusions, recommendation of

footing type with supporting calculations, recommended type of foundations for various structures, safe bearing capacity for different sizes of isolated footings at different depths, capacity of pile foundations including type (cast-in-situ under-reamed) & size (from 250mm dia to 750mm dia), & capacity of piles etc. as per Customer Technical specification & direction of Engineer-In-Charge.

- 1.4.2 Recommendation on removal or detainment of expansive soil under the structures / road, if expansive soil is met, including recommendation for any special treatment and specification for the materials to be used, construction method and equipment to be deployed.
- 1.4.3 Recommendations regarding slope of excavation & dewatering schemes, if required, and comments on the nature of soil & ground water with due regard to protective measures.
- 1.4.4 The contractor shall submit survey map of the site (AUTOCAD drawing along with Excel copy of the plot) indicating grid lines and contour lines, demarcating all permanent features like roads, railways, waterways, building, pump house, power lines, natural streams, nallah, well, fence lines, trees, etc. The contractor shall also submit the survey report consisting of general site observation such location of access roads, rivers, irrigation canals, existing drainage pattern of the site, possibility of water logging, mentioning reduced level of high flood level, any rock outcrops in the site, water level in the wells, etc. as per direction of Engineer-In-Charge / Customer's Divisional Engineer.
- 1.4.5 Soft copies of all above drawings & documents through email.

1.5.0 BOQ CUM PRICE SCHEDULE

BILL OF QUANTITY CUM PRICE SCHEDULE

Name of Project: 765/400/220kV Sub-Station, Vataman(New)

Name of Work:- Soil Investigation & Topography Survey work at 765/400/220 kV S/s at Vataman(New) & Eextention of 765 kV S/s at Halvad in Gujarat

Rev:00

S.No.	Description of Item	Quantity		Total Quantity	Unit	Unit Rate Excl. GST (RS)	Total amount Excl. GST (RS)
		Vataman	Halvad				
PART-A SOIL INVESTIGATION WORK							
1	Mobilization & Demobilisation of necessary equipment, tools, plants, manpower, etc., for conducting soil investigation at a project site. (Payment against this item shall be made for the oneway distance of the project site (Vataman) from the registered office of the bidder. Relevant document for the proof of distance shall be furnished with the claim.) Note: No seperate payment shall be made for Mobilization/Demobilisation for Halvad site.	1500		1500	KM	36.55	54825.78
2	Drilling boreholes of 150mm dia in accordance with the provision of IS:1892 at specified locations upto 15mtr depth into vergin soil to refusal whichever occurs earlier including performing SPT,collecting disturbed and undisturbed samples, recording watertable etc., all complete as per specification including backfilling of boreholes as per direction of Engineer-In-Charge.	300	30	330	RM	548.26	180925.074
2(b)	Add extra for rock drilling in boreholes where rock is encountered, all complete as per specification and direction of Engineer-In-Charge.	5	5	10	RM	2253.95	22539.51779
2(c)	Add extra for drilling boreholes beyond 15m depth.	5	5	10	RM	1583.85	15838.52821
3	Making trial pits of 2 m x 2 m in size extending to 4 m depths or as specified by customer at specified locations and taking undisturbed samples as per specification including backfilling of pit as per direction of Engineer-In-Charge	8	2	10	Nos	2558.54	25585.364
4	Conducting plate load test at specified location (loading intensity upto 8kg/cm ² or 40mm settlement whichever occurs earlier) all complete as per specification using plate of following size including backfilling as per direction of Engineer-In-Charge: 450mm X 450mm/ 600mm X 600mm	2	-	2	Nos	29240.42	58480.832
5	Conducting Field California Bearing Ratio tests at specified locations complete as per specification including backfilling as per direction of Engineer-In-Charge.	4	-	4	Nos	3655.05	14620.208
6	Conducting laboratory tests on soil and water samples all complete as per customer specification clause No. 2.8 "LABORATORY TEST".(Payment against this item shall be made based on the total no. of boreholes driven as per Item No.2(a) however, charges for Laboratory testing of the samples collected from trial pits/plate load test pits shall be deemed to be inclusive in this item.). Note: The Laboratory tests shall be carried out at any Govt approved Engineering college/NIT/ NABL accredited laboratories.	20	2	22	Per Bore-hole	1583.85	34844.76206
7	Conducting Electrical resistivity test(ERT) as per specification including all necessary arrangement required to conducting the test as per customer Technical Specification.	64	24	88	Nos	1766.61	155461.277
8	Furnishing Soft copy of draft report for BHEL/Customer Comment and 5 copies of Signed final report in Hard Copy.	1	1	2	Lot	7310.10	14620.208

S.No.	Description of Item	Quantity		Total Quantity	Unit	Unit Rate Excl. GST (RS)	Total amount Excl. GST (RS)
		Vataman	Halvad				
	PART-A SOIL INVESTIGATION WORK						
	PART-B TOPOGRAPHY SURVEY WORK						0o
1	Detailed topographical survey of entire substation land, construction of bench marks, transfer of the reduced levels & coordinates to the bench marks (As per Enclosed Drawing), preparation of survey report, survey map & contour plan, all complete as per mentioned scope of work including cost of mobilization & demobilization, manpower, tools & tackles, equipment, etc. as per direction of Engineer-In-Charge.	225000	33750	258750	Sqm	0.24	61473.40583
2	Furnishing Survey Map in AUTOCAD as well as Excel Sheet showing Reduced level at grid of 5m x5m, Hard copies of survey map, optimum quantity of Earthwork in cutting & filling with proposed F.G.L and Survey Report as mentioned in the Clause 1.4.0 (Soft Excel copy of draft report/ drawing for BHEL/Customer review & Four copies of Signed final report/ drawings) and as per direction of Engineer-In-Charge.	1	1	2	Lot	9137.63	18275.26
TOTAL AMOUNT (PART A + PART B) (RS.) =							657490.00



TECHNICAL SPECIFICATION
FOR
TOPOGRAPHICAL SURVEY

SPEC. NO.

VOLUME IIB

SECTION D

REV. NO. 00

DATE

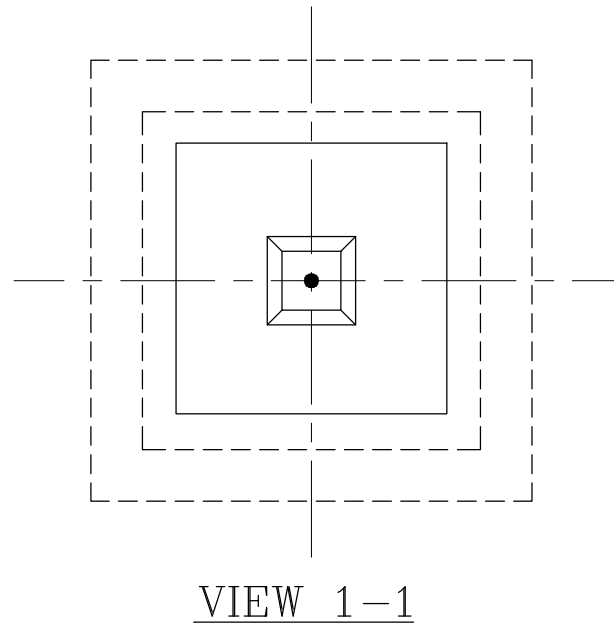

VIEW 1-1

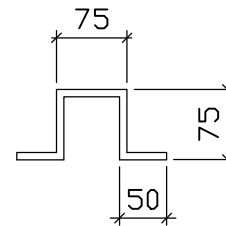

LUG DETAILS

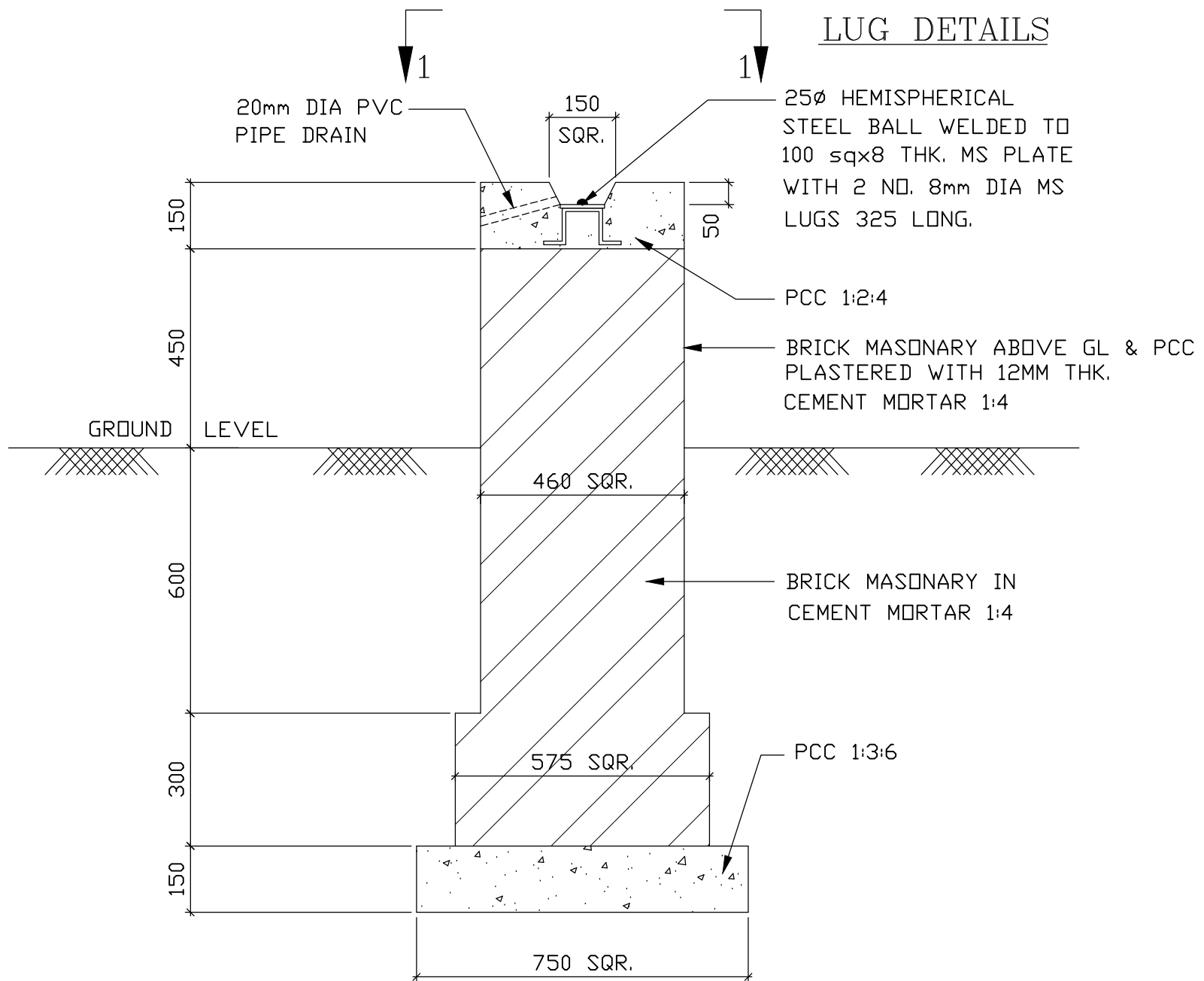

FIG. 1
BENCH MARK PILLAR

NOTES

1. ALL DIMENSIONS ARE IN MM
2. ALL MATERIALS AND WORKMANSHIP SHALL BE AS PER SPECIFICATION & RELEVANT IS CODES



TECHNICAL SPECIFICATION
FOR
TOPOGRAPHICAL SURVEY

SPEC. NO.	
VOLUME IIB	
SECTION D	
REV. NO. 00	DATE

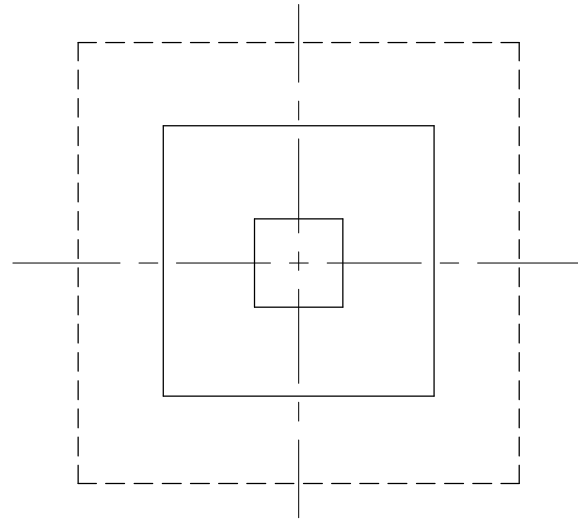

VIEW 1-1

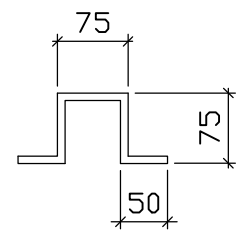

LUG DETAILS

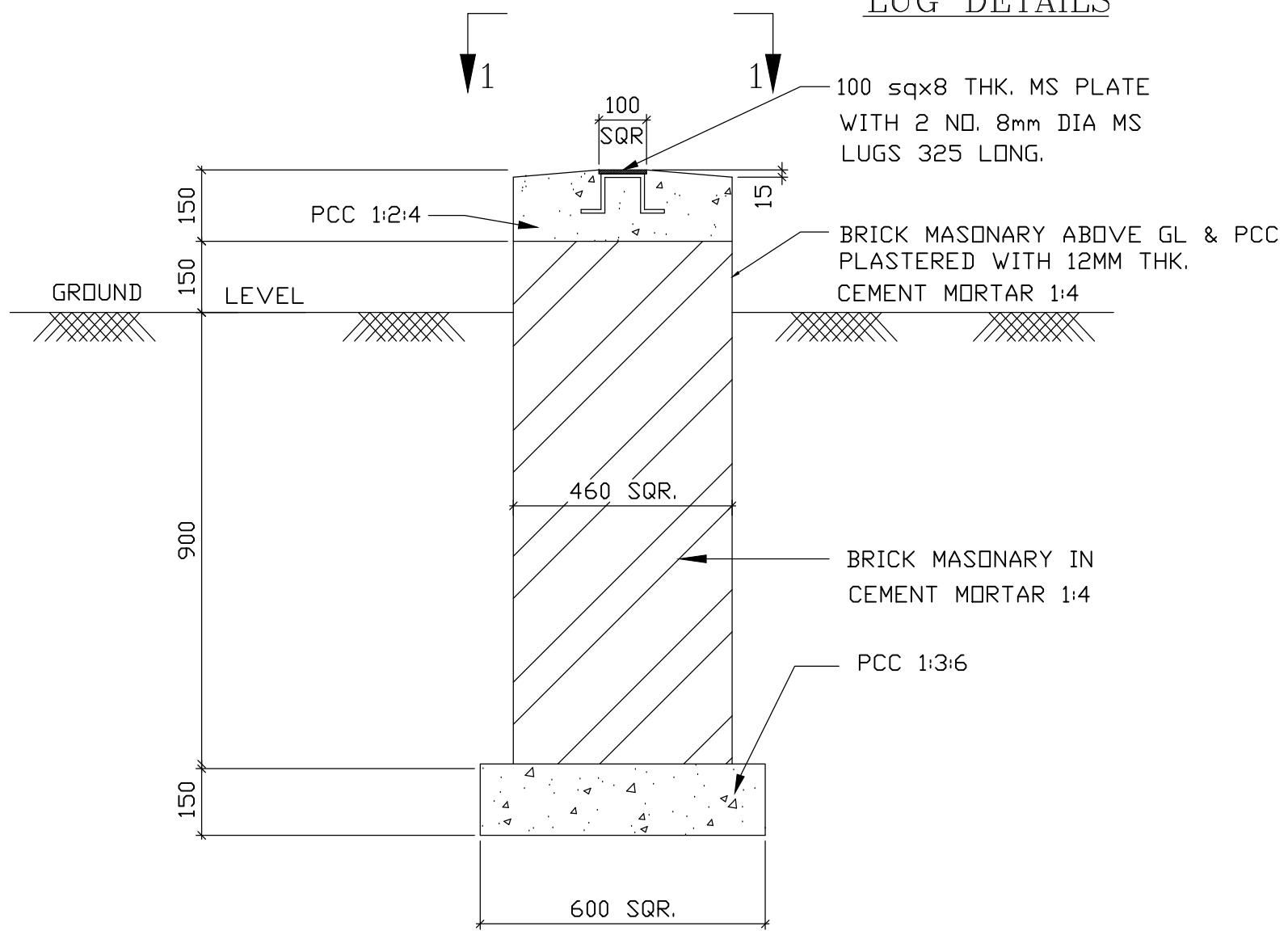

FIG. 2

GRID PILLAR/REFERENCE PILLAR

NOTES

1. ALL DIMENSIONS ARE IN MM
2. ALL MATERIALS AND WORKMANSHIP SHALL BE AS PER SPECIFICATION & RELEVANT IS CODES

SECTION -2

STANDARD TECHNICAL SPECIFICATION

Standard Tech Spec for Soil Investigation (Doc. No. TB-XXX-404-607-004 Rev No: 00) enclosed.

STANDARD TECHNICAL SPECIFICATION

2.1.0 BORE HOLES

- a. Drilling of bore holes of 150 mm dia. in accordance with the provisions of IS: 1892, to 15m depth or to refusal whichever occurs earlier. By refusal it shall mean that a standard penetration blow count (N) of 100 is recorded for 30 cm penetration. However, in case where deep pile foundations are envisaged, the depths have to be regulated as per codal provisions. In cases where rock is encountered, coring in bore holes shall be carried out to 3 M in bed rock and continuous core recovery is achieved.
- b. Performing Standard Penetration Tests at approximately 1.5m intervals in the bore holes starting from 1.5 m below ground level onwards and at every change of stratum. The disturbed samples from the standard penetrometer shall also be collected for necessary tests.
- c. Collecting undisturbed samples of 100/75 mm diameter 450 mm long from the bore holes at intervals of 1.5m and every change of stratum starting from 1.0m below ground level onwards in clayey strata.
- d. Collecting disturbed samples from the bore holes at intervals of 1.5m and every change of stratum starting from 1.0m below ground level onwards in clayey strata.
- e. Recording of water table depth & collection of water sample.
- f. All samples, both disturbed and undisturbed, shall be identified properly with the bore hole number and depth from which they have been taken. The sample shall be sealed at both ends of the sampling tubes with wax immediately after the sampling and shall be packed properly and transported to the Contractor's laboratory without any damage or loss.
- g. The logging of the boreholes shall be compiled immediately after the boring is completed and a jointly signed copy of the bore log shall be handed over to the site representative of BHEL/Customer.
- h. On completion of each hole, the Contractor shall backfill all bore holes as directed by the BHEL/Customer. The backfill material can be the excavated material**

2.2.0 DYNAMIC CONE PENETRATION TEST

- a. Dynamic cone penetration tests shall be carried out with the circulation of

bentonite slurry at specified locations and a continuous record of penetration resistance (NG) up to 15.00m from natural ground level or the refusal shall be maintained by the Contractor. IS: 4968 (Part-2) shall be followed for carrying out the test and for reporting of results.

- b. The location for the tests shall be as directed by BHEL/Customer. On completion of the test, the results shall be presented as a continuous record as the numbers of blows required for every 300 mm penetration of the cone into the soil.

2.3.0 TRIAL PITS

Trial pits shall be excavated at specified locations. The trial pits shall be 2m x 2m in size extending to 4m in depth, or as specified by BHEL/Customer. Undisturbed samples shall be taken from the trial pits at 1.5 m interval & every change of startum.

2.4.0 PLATE LOAD TEST

- a. Plate load test shall be conducted to determine the bearing capacity, modulus of subgrade reaction and load/settlement characteristics of soil at shallow depths by loading a plane and level steel plate kept at the desired depth and measuring the settlement under different loads, until a desired settlement takes place or failure occurs, The specification for the equipment and accessories required for conducting the test, the test procedure, field observations and reporting of results shall conform to IS : 1888, Modulus of subgrade reaction shall be conducted as per IS: 9214. **The location(s) and depth of the test shall be as specified by BHEL/Customer.** (Depth shall be upto a maximum of 3.00m below the natural ground level).
- b. The size of the pit in plate load test shall not be less than five times the plate size and shall be taken upto the specified depth. All provisions regarding excavation and visual examination of pit shall apply here.
- c. Unless otherwise specified the reaction method of loading shall be adopted. Settlement shall be recorded from dial gauges placed at four diametrically opposite ends of the test plate.
- d. The load shall be increased in stages. Under each loading stage, record of Time vs. Settlement shall be kept as specified in IS: 1888.
- e. **Backfilling of the pit shall be carried out as per the directions of the Owner. Unless otherwise specified the excavated soil shall be used for this purpose. In cases of gravel-boulder or rocky strata, respective relevant codes shall be followed for tests.**

2.5.0 FIELD CALIFORNIA BEARING RATIO TEST

This test shall be carried out to obtain the properties of soil required for the construction of

roads. The equipments and accessories required for carrying out the test, test procedure, recording of observations and presentation of results shall conform to IS: 2720 part XXXI.

2.6.0 WATER SAMPLE

Representative samples of ground water shall be taken when ground water is first encountered before the addition of water to aid drilling of boreholes. The samples shall be of sufficient quantity for chemical analysis to be carried out and shall be stored in air-tight containers.

2.7.0 LABORATORY TESTS

2.7.1 The laboratory tests shall be carried out progressively during the field work after sufficient number of samples have reached the laboratory in order that the test results of the initial bore holes can be made use of in planning the later stages of the field investigation and quantum of laboratory tests.

2.7.2 All samples brought from field, whether disturbed or undisturbed shall be extracted/prepared and examined by competent technical personnel, and the test shall be carried out as per the procedures laid out in the relevant I.S. Codes.

The following laboratory tests shall be carried out for **undisturbed sample**:

- (i) Tri axial compression test and determination of shear parameters ($C-\phi$) as per IS -2720 (Part ix) IS- 2720 (Part- xii) ,IS 2720 (Part xiii) on silty /sandy soil.
OR Consolidation Test as per IS -2720 (Part xv) on clay soil.
- (ii) Sieve analysis test as per IS -2720 (Part iv).
- (iii) Atterberg's Limit test as per IS-2720 (Part v).
- (iv) Particle size analysis test as per IS -2720 (Part iv).
- (v) Natural moisture content test as per IS 2720(Part vi).
- (vi) Wet density test & dry density test as per IS 2720 (Part vi).
- (vii) Specific gravity test as per IS 2720 (Part iii) section 2
- (viii) Chemical tests on soil and water to determine the carbonates, sulphates, nitrates, chlorides, Ph. value, and organic matter and any other chemical

harmful to the concrete foundation.

- (ix) Rock quality designation (RQD), RMR in case when rock is encountered.

The following laboratory tests shall be carried out for **disturbed sample**:

- (i) Sieve analysis test as per IS -2720 (Part iv).
- (ii) Atterberg's Limit test as per IS-2720 (Part v).

2.8.0 ELECTRICAL RESISTIVITY TESTS

- 2.8.1** This test shall be conducted to determine the electrical resistivity of soil required for designing safety grounding system for the entire sub-station area. The specification for the equipment and other accessories required for performing the test, test procedure and report-ing of field observations shall conform to IS: 3043. The test shall be conducted using Wenner's four electrode method as specified in IS: 1892, Appendix-B2. Unless otherwise specified, at each test location the test shall be conducted along two perpendicular lines parallel to the co-ordinate axes. On each line a minimum of 8 to 10 readings shall be taken by changing the spacing of the electrodes from an initial small value of 0.5m upto a distance of 50 m.

2.9.0 TEST RESULTS AND REPORTS

- 2.9.1** The Contractor shall submit the detailed report wherein information regarding the geological details of the site, summarized observations and test data, bore logs, and conclusions & recommendations on the type of foundations with supporting calculations for the recommendations are given. Initially, the report shall be submitted by the Contractor in draft form and after the draft report is approved, the final report in desired no. of copies shall be submitted. The test data shall bear the signatures of the contractor and site representative of BHEL/Customer.

- 2.9.2** The report shall include, but not limited to the following :

- (i) A plan showing the locations of the exploration work i.e. bore holes, dynamic cone penetration tests, trial pits, plate load test, etc.
- (ii) Bore Logs: Bore logs of each bore holes clearly identifying the stratification and the type of soil stratum with depth. The values of Standard Penetration Test (SPT) at the depths where the tests were conducted on the samples collected at various depths shall be clearly shown against that particular stratum.
- (iii) Test results of field and laboratory tests shall be summarized strata wise as well in combined tabular form. All relevant graphs, charts tables, diagrams and photographs, if any, shall be submitted along with report. Sample illustrative

reference calculations for settlement, bearing capacity, pile capacity shall be enclosed.

- (iv) Recommendations: The report should contain specific recommendations for the type of foundation for the various structures envisaged at site. The Contractor shall acquaint himself about the type of structures and their functions from BHEL/Customer. The observations and recommendations shall include, but not limited to the following:
- (a) Geological formation of the area, past observations or historical data, if available, for the area and for the structures in the nearby area, fluctuations of water table etc.
 - (b) Recommended type of foundations for various structures. If piles are recommended, the type, size and capacity of pile and groups of piles shall be given after comparing different types and sizes of piles and pile groups.
 - (c) Allowable bearing pressure on the soil at various depths for different sizes of the foundations based on shear strength and settlement characteristics of soil with supporting calculations. Minimum factor of safety for calculating net safe bearing capacity shall be taken as 2.5/3.0(As advised by BHEL/Customer).
 - (d) Recommendation regarding liquefaction characteristics of soil.
 - (e) Recommendations regarding slope of excavations and dewatering schemes, if required.
 - (f) Comments on the chemical nature of soil and ground water with due regard to deleterious effects of the same on concrete and steel and recommendations for protective measures.
 - (g) If expansive soil is met with, recommendations on removal or retainment of the same under the structure, road, drains, etc. shall be given. In the latter case detailed specification of any special treatment required including specification or materials to be used, construction method, equipments to be deployed etc. shall be furnished. Illustrative diagram of a symbolic foundation showing details shall be furnished.
 - (h) Recommendations for additional investigations beyond the scope of the present work, if considered necessary.

SECTION -3

ENCLOSURES TO THE SPECIFICATION

(a) Customer Specification

STANDARD
TECHNICAL SPECIFICATION
FOR
SUBSTATION- CIVIL WORKS

SUB-STATION CIVIL WORKS – REV 11A



पावर ग्रिड कारपोरेशन ऑफ इंडिया लिमिटेड

(भारत सरकार का उद्यम)

POWER GRID CORPORATION OF INDIA LIMITED

(A GOVERNMENT OF INDIA ENTERPRISE)

Document Code no.:

TECHNICAL SPECIFICATION: CIVIL WORKS

C/ENGG/SPEC/CIVIL/REV -11A/JUN'18

CONTENTS: TECHNICAL SPECIFICATION CIVIL WORK – 11A

Description		Page No.
Salient changes made over previous TS Rev-11A		4
Salient changes made over previous TS Rev-11		5
1.0	General	6
2.0	Geotechnical Investigation	7
2.1	Scope	7
2.2	Bore Holes	8
2.3	Trial Pits	8
2.4	Electrical Resistivity Test	8
2.5	Plate Load Test	10
2.6	Water Sample	10
2.7	Back Filling Of Bore Holes	11
2.8	Laboratory test	11
2.9	Test results and Reports	11
3.0	Standard drawings	13
3.1	Road, road culverts and rail cum road	14
3.2	Drains	15
3.3	Chain link fencing and switchyard gate	15
3.4	Rain water harvesting	15
3.5	Cable trenches	16
3.6	Boundary wall	16
4.0	Stone spreading and anti-weed treatment	20
5.0	Excavation and backfill of foundation	22
6.0	Cement	23
7.0	Chemical Admixture & Additives	24
8.0	Reinforced Concrete Cement	24
8.1	Design Mix Concrete	24
8.2	Volumetric Mix Concrete	25
9.0	Reinforcement Steel	25
10.0	Drawing and design to be developed by contractor/ employer during engineering	26
10.1	Control room building	26
10.2	GIS building / GIS hall	27
10.3	Building design consideration	29
10.4	Design loads	31
10.5	Design of foundation for building & other switchyard structures	33
10.6	Design of transformer and reactor foundation	34
10.7	Design of fire protection wall	35
10.8	Design of water tanks, channels, sumps, trenches and other underground structures	35
10.9	Internal finish schedule for control room building & GIS hall either RCC/PEB	36
10.10	False ceiling details	41
10.11	Water proofing treatment	42
10.12	Specification for plumbing, sanitation & water supply etc.	43

20.26	Boundary wall	78
20.27	Site levelling	79

P R E F A C E

Salient changes made over previous TS -11

S No.	Ref Clause of Rev. 11A	Brief Description
1	1.1	Mention of “Approval of Employer for design/drawings” Insertion of order of precedence for Technical Specification, BIS code & CPWD specification
2	2.9.2.5	Signing and stamping of soil report by qualified Geotechnical engineer/ consultant
3	3.2.2, 3.4.2, 3.5.1	Layouts to be proposed by the contractor and approved by POWERGRID before execution
4	3.6	Weep holes/ gratings in boundary walls
5	3.6.3.7	“Cage” to be replaced with “design and drawing”
6	5.6 (a)	Supervision and safety of existing structures during dismantling works
7	8.0	Mentioning of IS 456-200 (latest) for RCC works.
8	8.1 & 8.2	Description of minor works for volumetric concreting. Clarity regarding Design mix added.
9	10.2	“Contractor” word added with vendor
10	10.2.6	RCC pedestal to finish at floor level
11	10.2.12	Clarity w.r.t floor finish of GIS hall
12	10.3.18	“working stress method” replaced by “limit state method” for PEB design
13	10.3.16	All design and detailing (including ductile) as per latest BIS standards
14	20.0	Reference of IS 1200 in case of ambiguity.

P R E F A C E

Salient changes made over previous TS -10

S No.	Ref Clause of Rev. 11	Brief Description
1	2.9.2.4 (iv)	Liquefaction related in soil report
2	3.5.1	Provision of pre-cast cable trench
3	3.6	Specification of RCC frame brick masonry wall & stone masonry wall
4	3.6.4	structural steel angle supporting barbed wire/concertina coil over boundary wall shall be painted with epoxy paint
5	4.1, 4.2	“Sand” replaced with “fine aggregate”
6	5.0 & 20.1	Excavation in hard rock as separate item
7	5.6	Dismantling and demolishing works
8	8.2.1	Restriction of volumetric mix concrete
9	9.0	Reinforcement steel grade revised to Fe 500D
10	10.1.1	CRB shall be RCC structure at both AIS and GIS substations.
11	10.2.1	Partition sheet for extension works in GIS hall
12	10.2.2	Reference of BIS standard
13	10.3.9	Plinth level raised to 750 mm above FGL.
14	10.3.24	Air pressure maintaining measures.
15	10.7.1	Provision of pre-cast firewall
16	10.9	Aluminium door windows replaced with uPVC sections
17	10.9.1	PU coating over total area of GIS hall
18	10.11.2	Roof treatment through graded concrete.
19	10.12.7	Provision of “triple layered” polyethylene water storage tank
20	11.3.2	Min. value of Zn-Al coating in roof and wall sheeting changed to 150 gm/sqm
21	13.22	Provision of Seamless galvalume rolling shutter
22	20.12.2 & 20.12.3	Payment of miscellaneous structural steel for GIS equipment in GIS hall

SECTION: CIVIL WORKS

1.0 GENERAL

- 1.1 All civil works shall be carried out as per design/drawings provided by the Employer/ Contractor and as per these specification provided by the Employer. *In case design/drawings are prepared by the contractor then these shall be approved by the employer before execution.* In case any item is not covered under specification then the same shall be carried out as per CPWD specification /applicable BIS Standards and Codes. Any item for which specification is not provided herein and is not covered under CPWD specification/ BIS Standards, the same shall be executed as per manufacturer guidelines with the approval of employer. All materials shall be of best quality conforming to relevant Indian Standards and Codes. In case of any conflict between Standards/ Code and Technical Specification, *the order of precedence shall be as under:*
- 1.1.1 *Technical specification,*
 - 1.1.2 *BIS codes*
 - 1.1.3 *CPWD specification.*
- The decision of engineer in charge in this regard shall be final and binding.*
- 1.2 Wherever reference to CPWD/BIS Codes is made, it shall be to the latest edition/revision of the same, issued up to 7 days prior to the date of opening of this tender.
- 1.3 The Contractor shall arrange all labour, tools, equipment, materials, temporary works, constructional plant & machinery, fuel supply, transportation and all other incidental items not shown or specified but as may be required for complete performance of the Works in accordance with drawings, specifications and direction of Employer.
- 1.4 All materials including cement, reinforcement steel, structural steel etc. shall be arranged by the Contractor.
- 1.5 The Contractor shall execute the work as per the Field Quality Plan (FQP) which is available on POWERGRID website. All testing required shall be arranged by the Contractor at his own cost.
- 1.6 The bidder shall fully apprise himself of the prevailing conditions at the proposed site, Climatic conditions including monsoon patterns, local conditions and site specific parameters, soil parameters, availability of construction material and shall include for all such conditions and contingent measures in the bid, including those which may not have been specifically brought out in the specifications.
- 1.7 Unless leveling is in the scope of the bidder, fairly leveled site with single level/terraces with different levels/ gradual slope shall be handed over to the Contractor, in a phased

manner. The finished ground level (FGL) with a tolerance of (+/-) 100mm shall be decided by the Employer. The layout and levels of all structure etc shall be made by the Contractor at his own cost from the general grids of the plot and benchmarks set by the Contractor and approved by the Employer. The Contractor shall provide all assistance in instruments, materials and personnel to the Employer for checking the detailed layout and shall be solely responsible for the correctness of the layout and levels.

In case leveling is in the scope of bidder, FGL shall be decided by the employer.

- 1.8 Employer has standardized its technical specification for various items/ works. Specification for items which are covered in the scope and as defined in Section project & BPS shall only be referred.
- 1.9 The material specification, workmanship and acceptance criteria shall be as per approved standard Field Quality Plan. In case certain item is not covered in FQP, it shall be constructed as per CPWD specification/ relevant BIS.

2.0 GEOTECHNICAL INVESTIGATION:

The Contractor shall perform a detailed soil investigation to arrive at sufficiently accurate conclusion regarding general as well as specific information about the soil profile and the necessary soil parameters of the site, in order to design and construct the foundation of the various structures safely and rationally.

A report to the effect shall be submitted by the Contractor for Employer's specific approval giving details regarding data proposed to be utilized for the design.

2.1 SCOPE:

This specification covers all the work required for detailed soil investigation and preparation of a detailed report. The work shall include mobilization of necessary equipment, providing necessary engineering supervision and technical personnel, skilled and unskilled labour etc. as required to carry out field investigation as well as, laboratory investigation, analysis and interpretation of data and results, preparation of detailed Geo-technical report including specific recommendations for the type of foundations and the allowable safe bearing capacity for different sizes of foundations at different founding strata starting from 0.5M from existing ground level for the various structures of the substation. The Contractor shall make his own arrangement for locating the co-ordinates and various test positions in field as per the information supplied to him and also for determining the reduced level of these locations with respect to the benchmark indicated by the Employer.

2.2 BORE HOLES:

- Bore holes of 150 mm diameter in accordance with the provisions of IS: 1892 at the rate of minimum one number bore hole per hectare up to 15meter depth into virgin soil or to refusal whichever occurs earlier shall be drilled. Total area of substation plot (including of Switchyard, Township and Future area) shall be considered for arriving at number of bore holes to be drilled. In any case number of boreholes shall not be less than five and shall not exceed twenty. By refusal it shall mean that a standard penetration blow count (N) of 100 is recorded for 30 cm penetration. In case rock is encountered within five meter from existing ground level, coring in all the boreholes shall be carried out up to 3 meter in rock.
- The Contractor shall carry out Standard Penetration Tests at approximately 1.5 m interval in the borehole starting from 0.5 m below ground level onwards and at every change of stratum. The disturbed samples from the standard penetrometer shall also be collected for necessary tests.
- The Contractor shall collect undisturbed samples of 100/75 mm diameter 450 mm long from the bore holes at intervals of 2.5 m and every change of stratum starting from 0.5 m below ground level onwards in clayey strata.
- The depth of Water Table, if encountered, shall be recorded in each borehole. In case the soil investigation is carried out in winter/summer, the water table for rainy season shall be collected from reliable sources and recorded in the report.
- All samples, both disturbed and undisturbed, shall be identified properly with the borehole number and depth from which they have been taken.
- The sample shall be sealed at both ends of the sampling tubes with wax immediately after the sampling and shall be packed properly and transported to the laboratory without any damage or loss.
- The logging of the boreholes shall be compiled immediately after the boring is completed and a copy of the bore log shall be handed over to the Engineer-in-charge.

2.3 TRIAL PITS:

Trial pits shall be carried out at minimum one location per hectare as directed by the Employer. In case hard rock is encountered in trial pit, test need not be carried out. Total area of substation plot (including of Switchyard, Township and Future area) shall be considered for arriving at number of Trial Pit to be excavated. Minimum number of trial pits shall be five and maximum number shall be ten. The trial pits shall be 2 m x 2 m in size extending to 4 m depths, or as specified by the Employer. Undisturbed samples shall be taken from the trial pits as per the direction of the Employer.

2.4 ELECTRICAL RESISTIVITY TEST :

The resistivity of earth varies over a wide range depending on its moisture content, temperature, salt content and compactness. Therefore earth resistivity test shall be conducted preferably during the dry season in order to get conservative results.

2.4.1 TEST LOCATION

In the evaluation of earth resistivity for the substations, at least eight test directions shall be chosen from the centre of the substation to cover the entire area including the future area. The number of test points shall be as per approved drawing.

2.4.2 PRINCIPLE OF TEST

Wenner's four electrode method shall be used. In this method, four small electrodes shall be buried in four small holes in the earth along a straight line at equal intervals. A test current (I) by earth resistivity tester shall be passed between two outer electrodes and the voltage difference (V) between the two inner electrodes shall be measured. The test current (I) thus flowing into the earth, produces an electric field proportional to its density and to the resistivity of the soil. The voltage (V) measured between the inner electrodes is proportional to the field. Consequently, the resistivity will be proportional to the ratio of the voltage to current. Thus the resistivity shall be calculated from the following equation.

$$\rho_a = \frac{4\pi a R}{1 + \frac{2a}{\sqrt{a^2+4b^2}} - \frac{a}{\sqrt{a^2+b^2}}}$$

Where,

- ρ_a is the apparent resistivity of the soil in Ω -m
- R is the measured resistance in Ω
- a is the distance between adjacent electrodes in metres
- b is the depth of the electrodes in m

2.4.3 TEST PROCEDURE

In the selected test point and chosen direction, four electrodes with insulated connecting wires shall be driven into the earth along a straight line of equal intervals (a). The depth of the electrodes in the earth shall be of the order of 15 cm to 20 cm. The megger shall be placed on a steady and approximately level base, the link between terminals P1 and C1 shall be opened and the four electrodes connected to the instrument terminals. An appropriate range on the instrument shall be selected to obtain clear readings avoiding the two ends of the scale as far as possible.

Resistivity shall be calculated by substituting the value of R in the above equation. The test shall be repeated in a chosen direction with a number of different electrode spacing, increasing from 2m to 50m preferably in the steps of 2, 5, 10, 15, 25 and 50m. When the spacing is increased gradually from low values, at a stage, it may be found that the resistivity reading is more or less constant irrespective of the increase in the electrode spacing. The resistivity for this spacing is noted and taken as the resistivity for that direction. In a similar manner, resistivity for at least eight equally spaced directions from the centre of the test points shall be measured. These measurements shall be repeated for all test points.

NOTES:-

- i. Soil resistivity points shall preferably be one number in each 100mx100m grid and number of test points shall be such that the entire substation including the future area is covered.
- ii. Average resistivity value of all eight directions shall be considered for design of earthing system.
- iii. Soil resistivity measurement may be done in dry season. Small amount of water may be applied at electrodes for making proper contact between the electrodes and soil.

2.5 PLATE LOAD TEST

Plate load test shall be conducted to determine the bearing capacity, modulus of sub grade reaction and load/settlement characteristics of soil at shallow depths by loading a plane and level steel plate kept at the desired depth and measuring the settlement under different loads, until a desired settlement takes place or failure occurs. The specification for the equipment and accessories required for conducting the test, the test procedure, field observations and reporting of results shall conform to IS: 1888. Modulus of sub grade reaction shall be conducted as per IS: 9214. Plate load test shall be conducted at two locations to be decided during detailed engineering at the proposed foundation depth below finished ground level for determining the bearing capacity.

Undisturbed tube samples shall be collected at 0.5 m and 2.5m depths from natural ground level for carrying out laboratory tests

The size of the pit in plate load test shall not be less than five times the plate size and shall be taken up to the specified depth. All provisions regarding excavation and visual examination of pit shall apply here.

Unless otherwise specified the reaction method of loading shall be adopted. Settlement shall be recorded from dial gauges placed at four diametrically opposite ends of the test plate.

The load shall be increased in stages. Under each loading stage, record of Time v/s Settlement shall be kept as specified in IS: 1888.

Backfilling of the pit shall be carried out as per the directions of the Employer. Unless otherwise specified the excavated soil shall be used for this purpose. In cases of gravel-boulder or rocky strata, respective relevant codes shall be followed for tests.

2.6 WATER SAMPLE

Representative samples of ground water shall be taken when ground water is first encountered before the addition of water to aid drilling of boreholes. The samples shall be of sufficient quantity for chemical analysis to be carried out and shall be stored in air-tight containers.

2.7 BACK FILLING OF BORE HOLES

On completion of each hole, the Contractor shall backfill all bore holes as directed by the Employer. The backfill material can be the excavated material.

2.8 LABORATORY TEST

2.8.1. The laboratory tests shall be carried out progressively during the field work after sufficient number of samples has reached the laboratory in order that the test results of the initial bore holes can be made use of in planning the later stages of the field investigation and quantum of laboratory tests.

2.8.2. All samples brought from field, whether disturbed or undisturbed shall be extracted/prepared and examined by competent technical personnel, and the test shall be carried out as per the procedures laid down in the relevant I.S. Codes.

The following laboratory tests shall be carried out

- i) Visual and Engineering Classification
- ii) Liquid limit, plastic limit and shrinkage limit for C- \emptyset soils.
- iii) Natural moisture content, bulk density and specific gravity.
- iv) Grain size distribution.
- v) Swell pressure and free swell index determination.
- vi) California bearing ratio.
- vii) Consolidated drained test with pore pressure measurement.
- viii) Chemical tests on soil and water to determine the carbonates, sulphates, nitrates, chlorides, Ph value, and organic matter and any other chemical harmful to the concrete foundation.
- ix) In case of rock samples following tests shall also be conducted:
 - Rock quality designation (RQD), RMR.
 - UCC test.
 - Point load index test.

2.9 TEST RESULTS AND REPORTS

2.9.1 The Contractor shall submit the detailed report in four (4) copies wherein information regarding the geological detail of the site, summarised observations and test data, bore logs, and conclusions and recommendations on the type of foundations with supporting calculations for the recommendations. Initially the Contractor shall submit

draft report and after the draft report is approved, the final report in four (4) copies shall be submitted. The site test data shall bear the signatures of the Investigation Agency, Vendor and also site representative of Employer.

2.9.2 The report shall include, but not limited to the following:-

2.9.2.1 A plan showing the locations of the exploration work i.e. bore holes, trial pits, Plate load test etc.

2.9.2.2 Bore Logs: Bore logs of each bore holes clearly identifying the stratification and the type of soil stratum with depth. The values of Standard Penetration Test (SPT) at the depths where the tests were conducted on the samples collected at various depths shall be clearly shown against that particular stratum.

2.9.2.3 Test results of field and laboratory tests shall be summarized strata wise as well as in combined tabular form. All relevant graphs, charts tables, diagrams and photographs, if any, shall be submitted along with report. Sample illustrative reference calculations for settlement, bearing capacity, pile capacity shall be enclosed.

2.9.2.4 The report should contain specific recommendations for the type of foundation for the various structures envisaged at site. The Contractor shall acquaint himself about the type of structures and their functions from the Employer. The observations and recommendations shall include but not limited to the following:

- i) Geological formation of the area, past observations or historical data, if available, for the area and for the structures in the nearby area, fluctuations of water table etc.
- ii) Recommended type of foundations for various structures. If piles are recommended the type, size and capacity of pile and groups of piles shall be given after comparing different types and sizes of piles and pile groups.
- iii) Allowable bearing pressure on the soil at various depths for different sizes of the foundations based on shear strength and settlement characteristics of soil with supporting calculations. Minimum factor of safety for calculating net safe bearing capacity shall be taken as 2.5.
- iv) Recommendation regarding liquefaction potential/characteristics of soil during ground shaking and possible remedies shall be provided.
- v) Recommendations regarding slope of excavations and dewatering schemes, if required.
- vi) Comments on the Chemical nature of soil and ground water with due regard to deleterious effects of the same on concrete and steel and recommendations for protective measures.
- vii) If expansive soil is met with, recommendations on removal or detainment of the

same under the structure, road, drains, etc. shall be given. In the latter case detailed specification of any special treatment required including specification or materials to be used, construction method, equipments to be deployed etc. shall be furnished. Illustrative diagram of a symbolic foundation showing details shall be furnished.

- viii) Recommendations for additional investigations beyond the scope of the present work, if considered such investigation as necessary.
- ix) In case of foundation in rocky strata, type of foundation and recommendation regarding rock anchoring etc. should also be given based on RMR value

2.9.2.5 All Geotechnical investigation reports must be signed and stamped by qualified Geotechnical engineer/ consultant even if they have been prepared by NABL accredited test labs.

3.0 STANDARD DRAWINGS:

- i) Standard drawings have been developed for Control Room Building, Switchyard Panel Room, Fire Fighting Pump House & Water Tank, Towers & Equipments Foundations, Transit Camp, Septic Tank & Soak Pit, Roads, Road Culverts & Rail Cum Road, Drains, Chain Link Fence & Switchyard Gate, Rain Water Harvesting by the Employer and are enclosed with the tender documents.
- ii) These drawings are good for construction and are also available on POWERGRID website. Additional prints if any required, can be downloaded from the website.
- iii) All tender drawings shall be read in conjunction with this specification. Discrepancy if any shall be brought to the notice of Employer prior to quote.
- iv) All foundation drawings including foundations for buildings, towers, equipments etc shall be released to the Contractor after award in a phased manner, after receiving the geotechnical investigation report.
- v) Drawings for transformer, reactor foundations and fire walls are not enclosed and shall be made available to the successful bidders by the Employer during detailed engineering.
- vi) In case the site conditions warrant any special type of foundations to be used, the same shall be designed and issued by the Employer to the Contractor during detailed engineering unless otherwise mentioned in section project.
- vii) Drawings for any non-standard tower or equipment and their foundation, if required, shall be designed by the Employer and made available to the Contractor during detailed Engineering unless otherwise mentioned in section project.
- viii) Drawings that have been mentioned and to be issued by the Employer to the Contractor during detailed Engineering shall be made available to the Contractor as per the agreed work schedule finalized after award.
- ix) Items/ components of buildings not explicitly covered in the specification but required for completion of the project shall be deemed to be included in the scope.

The material which can be quarried/excavated with pick, shovels, jumpers, scarifiers, crowbars etc. and other mechanical implements. All materials involved under this classification are as below:

All kind of soils includes various types of soils, plain concrete, shingle and river or nallah bed boulders, soling of road, paths and hard core, macadam surface of any description, stone masonry below the ground level, soft conglomerate and laterite stone which can be detached from the matrix with picks and shovel.

Soft/disintegrated Rock (Not requiring blasting): Rock and boulders which may be quarried and split with crow bars and other mechanical implements etc. It includes lime stone, sand stone, hard conglomerate.

19.5.2 HARD ROCK:

All kind of rocks which can be excavated by machines and requires blasting chiselling in edging or in another agreed method. This can be classified under the following categories:

- a) Hard Rock (Requiring Blasting)-This shall comprise:
 - i) Any rock for the excavation of which the use of mechanical plant or blasting is required;
 - ii) Reinforced cement concrete (reinforcement cut through but not separated from the concrete) below ground; and
 - iii) Boulder requiring blasting.

- b) Hard Rock (Blasting Prohibited)

Hard rock requiring blasting as described under (a) above but where blasting is prohibited for any reason and excavation has to be carried out by chiselling, wedging or any other agreed method.

19.5.3 AUTHORITY FOR CLASSIFICATION EXCAVATION:

The classification of excavation shall be decided by the Engineer-in-Charge and his decision shall be final and binding on the Contractor. Merely the use of explosives in excavation will not be considered as a reason for higher classification unless blasting is clearly necessary in the opinion of the Engineer-in-Charge. All the excavated material shall be the property of the POWERGRID.

19.6 SITE LEVELLING OPERATIONS:

19.6.1 SETTING OUT AND MARKING PROFILES.

After the site has been cleared, the limits of site levelling shall be set out true to lines, curves, slopes, grades and sections as shown on the drawings or as directed by the

Engineer-in-Charge. The Contractor shall provide all labour, survey instruments and materials such as strings, pegs, nails, bamboos, stones, lime, mortar, concrete, etc., required in connection with the setting out of works and establishment of bench marks. A grid system of co-ordinates shall be established by the Contractor at the site. The Contractor shall be responsible for the maintenance of permanent reference pillars, bench marks and other marks and stakes as long as in the opinion of the Engineer-in-Charge they are required for the work. All such marks/pillars shall be removed by the Contractor at his own cost as soon as the purpose is over.

Masonry pillars shall be erected at suitable places in the area to serve as bench marks for the execution of the work. These bench marks shall be connected with G.T.S. of any other permanent bench mark approved by the Engineer-in-Charge. Necessary profiles with pegs, bamboos and strings or "*Burgeis*" shall be made to show the correct formation levels before the work is started and the same shall be approved by the Engineer-in-Charge. The contractor shall supply all labour, tools, equipment, materials, safeguards and incidentals necessary for setting out and making profiles and burgeis & pillars for the work at his own cost. The profiles and burgeis shall be maintained during the execution of the work.

Marks/pillars shall invariably be diagonal unless otherwise directed, and should be such that their average height is representative of average depths. Payments will be made on the basis of volume measurement after with-holding the amount corresponding to 5% of the volume of earth work on account of non-removal of marks/pillars.

The Contractor shall have to remove the marks/pillars and utilise the earth spoils as per the directions of the Engineer-in-Charge. The withheld amount as stated in the above paragraph may be paid after certification of the Engineer in-Charge; regarding his full satisfaction and to the effect that the mark/pillars, etc. have been removed and soils/earth thereof has been utilised as directed by him.

If the contractor fails to remove, partly or fully the marks/pillars in the manner and within the period as aforesaid double the amount spent by the owner for removal of marks/pillars will be recovered from dues payable to the contractor.

19.6.2 EXCAVATION AND FILLING

All excavations shall be carried out in conformity with the directions laid herein under and in a manner approved by the Engineer-in-Charge. The work shall be so done that the suitable materials available from excavation are satisfactorily utilised as decided upon before disposal.

While planning or executing excavation, the Contractor shall take all adequate precautions against soil erosion, water pollution, air pollution etc.

**FORMAT OF NO DEVIATION CERTIFICATE
(To be submitted in the bidder's letter head)**

REF:

Dated.....

**BHARAT HEAVY ELECTRICALS LIMITED,
TRANSMISSION BUSINESS GROUP,
Plot No- 25, Sector- 16A, Noida,
Distt. Gautambudh Nagar, UP-201301**

SUBJECT: Tender for "SOIL INVESTIGATION & TOPOGRAPHY SURVEY WORK AT 765/400/220KV AT VATAMAN (NEW) & EXTENSION OF 765 KV S/S AT HALVAD IN GUJARAT".

TENDER NO.: - TBSM/VATAMAN & HALVAD/SI/TENDER/23-24

Date: - 02.04.2024

Dear Sir,

With reference to above, this is to confirm that as per tender conditions, we have visited subject site before submission of our offer and noted the job content & site conditions etc.

We also confirm that we have not changed / modified the tender documents as appeared in the website and in case of observance at any stage, it shall be treated as null and void. We hereby confirm that we have not taken any deviation from tender clauses together with other references as enumerated in the above referred NIT and we hereby convey our unqualified acceptance to all terms and conditions as stipulated in the tender and NIT. In the event of observance of any deviation in any part of our offer at a later date whether implicit or explicit, the deviations shall stand null & void.

We confirm to have submitted offer strictly in accordance with tender instructions.

Thanking you,

Yours faithfully,

(Signature, date & seal of authorized representative of the bidder)

DECLARATION FOR RELATION IN BHEL

(To be typed and submitted in the Letter Head of the Company/Firm of Bidder failing which the offer of Bidder is liable to be summarily rejected)

Ref:

Date.....

**To,
AGM/TBSM
BHARAT HEAVY ELECTRICALS LIMITED,
TRANSMISSION BUSINESS GROUP,
PLOT NO.-25, SECTOR-16A,
NOIDA - 201301 (U.P.)**

Dear Sir,

Sub: Declaration for relation in BHEL

Ref: 1) NIT/Tender Specification No.: **TBSM/VATAMAN & HALVAD/SI/TENDER/23-24, Date: - 02.04.2024**

I/We hereby submit the following information pertaining to relation/relatives of Proprietor/ Partner(s)/Director(s) employed in BHEL

Tick (√) any one as applicable:

1. The Proprietor, Partner(s), Director(s) of our Company/Firm DO NOT have any relation or relatives employed in BHEL

OR

2. The Proprietor, Partner(s), or Director(s) of our Company / Firm HAVE relation / relatives employed in BHEL and their particulars are as below:

a)

b)

Signature of the Authorized Signatory

Note:

- 1) Attach separate sheet, if necessary.
- 2) If BHEL Management comes to know at a later date that the information furnished by the Bidder is false, BHEL reserves the right to take suitable against the Bidder/ Contractor.

