

DUEDATE

23-04-2022

| SL | MATERIAL CODE ITEM DESCRIPTION | QUANTITY | UNIT | LOTNO | LOT DELIVERY QTY SCHEDULE |
|------------------|---|----------|------|----------|---------------------------|
| Item Description | Quantity | Unit | Lot | Quantity | Lot Date |
| 1 | HT4320022483 CHEVRON PACKING RING SET SUITA BLE FOR : ID 90 & OD 110 & NO M. DEPTH 35. (SET OF 5 PCS) WORKING PRESSURE 100 KG/CM2 (EQUIVALENT TO JW CHART NO. 431) . THE FABRIC REINFORCEMENT FOR THE CHEVRON PACKING SHOULD BE NYLON TO RESIST WATER ABSORP TION & DIMENSIONAL CHANGE SIZE: 90 ID X 110 OD and 35 Nom. Dep | 6 | ST | 1 | 6 31/08/22 |
| 2 | HT4320022491 PISTON GUIDE DIA.150 (GUIDE ST RIP KF) OF NON-METALLIC (MATER IAL-PTFE BRONZE) SUITABLE FOR WORKING PRESS.100 KG/CM2, TEST PRESS. 150 KG/CM2 AS PER SIMR IT CATALOGUE ARTICLE NO.-2416 9689,TYPE-KF,OD-150,ID-145, H-1 4.8 OR EQUIVALENT.VENDOR TO FURNISH COMPOSITION AND HARDNE SS OF MATERIAL QUOTED BY HIM. SIZE: PISTON GUIDE DIA 150 DIM.: DIA 150 | 4 | NO | 1 | 4 31/08/22 |
| 3 | HT4320022505 PISTON SEAL DIA.150 (OMEGAT OM K-MR),2 PC. SEAL SET CONSIST O F 1 PTFE BRONZE PROFILE RING AND 1 O-RING (NBR) AS PRELOAD COMP. SUIT. FOR WORKING P= 100 KG/CM2,TEST P=150KG/CM2 AS P ER SIMRIT CAT.ART. NO.-2417848 0,TYPE OMK-MR,OD-150,ID-129,H- 7.7 OREQUIV. VENDOR TO FUR. CO MPOS. & HARDNESS OF QUOTED MAT SIZE: PISTON SEAL DIA 150 DIM.: DIA 150 | 2 | ST | 1 | 2 31/08/22 |

| SL | MATERIAL CODE | QUANTITY | UNIT | LOTNO | LOT DELIVERY QTY SCHEDULE ITEM |
|--|---------------|----------|------|-------|-----------------------------------|
| DESCRIPTION | | | | | |
| 4 | HT4362019103 | 4 | NO | 1 | 4 31/08/22 |
| CUP SEAL (I/D 585 O/D 645) AS PER PURCHASE SPECIFICATION HT0 0202 (REV-01) & HT00203 (REV-0 2). SIZE: 585 X 645 | | | | | |
| 5 | HT4362019111 | 4 | NO | 1 | 4 31/08/22 |
| DRG: 32120220105 Var00 REV: 00 MUSIC NOTE SEAL FOR DISCHARGE VALVE AS PER DRAWING NO. 32120220105 AND TECHNICAL REQUIREMENTS THEREIN | | | | | |
| 6 | HT4362019138 | 4 | NO | 1 | 4 31/08/22 |
| DRG: 32120220108 Var00 REV: 00 SPECIAL SEAL FOR TRUNNION (I/D 585) AS PER DRG. NO. 32120220108 AND TECHNICAL REQUIREMENTS MENTIONED THEREIN. | | | | | |
| 7 | HT4362019154 | 4 | NO | 1 | 4 31/08/22 |
| DRG: 32120220107 Var01 REV: 00 ENDLESS MOULDED 'D'-SEAL DIA. 3480, ITEM NO. 01 OF DRAWING NO.32120220107 & TECHNICAL REQUIREMENTS MENTIONED THEREIN. | | | | | |
| 8 | HT4362019162 | 2 | NO | 1 | 2 31/08/22 |
| DRG: 32120220107 Var02 REV: 00 ENDLESS MOULDED 'D' SEAL DIA. 3490MM, ITEM NO.02 OF DRAWING NO.32120220107 & TECHNICAL REQUIREMENTS MENTIONED THEREIN. | | | | | |
| 9 | HT4362019170 | 2 | NO | 1 | 2 31/08/22 |
| DRG: 32120220107 Var03 REV: 00 ENDLESS MOULDED 'D' SEAL DIA. 3680MM, ITEM NO.03 OF DRAWING NO.32120220107 & TECHNICAL | | | | | |

| SL | MATERIAL CODE | QUANTITY | UNIT | LOTNO | LOT DELIVERY QTY SCHEDULE ITEM | DESCRIPTION |
|------------------------------------|---------------|----------|------|-------|-----------------------------------|-------------|
| REQUIREMENTS MENTIONED THEREIN. | | | | | | |

 ** IMPORTANT: This enquiry is 2 part tender. Techno-Commercial bid (Part-1) & Price Bids (Part-2) should be submitted in separate envelopes. These two envelopes should be submitted in a common sealed envelope. Techno-Commercial Bid shall contain detailed Technical Specification, Drawings Technical documents, Catalogues, taxes & duties, payment terms, delivery period, Validity of offer, Replica of Price Bid (Copy of price bid without price part) etc. The confirmation to the special terms & conditions must be submitted alongwith Techno-Commercial bid. -----

----- Special Instructions:

ESTIMATE IS BEING SENT IN SEALED &
 SIGNED ENVELOPE. GeMAR AND PTS ATTACHED
 . indent to be processed through OT
 route
 testing and certification as per ordering specification delivery is not sacrosanct
 and earlier delivery is preferred. -----

KAUSHAL MEENA
SENIOR ENGINEER



BHARAT HEAVY ELECTRICALS LIMITED

HEEP HARIDWAR INDIA-PIN 249403

FAX NO: 0091 1334 226462

PHONE NO: 8899026770

BHEL ENQUIRY No: T/T206/21/2892C1

M/s.....

Sub: BHEL-HEEP/OPEN-TENDER (Turbine) /2022/PPX-T/Seals/20212892

The Heavy Electricals Equipment Plant (HEEP) located in Haridwar, India is one of the major manufacturing plants of Bharat Heavy Electricals Ltd. The core business of HEEP includes design and manufacture of large steam and gas turbines, turbo generators and so on.

The tender is invited on *the NIC E-Procurement Portal* (<https://eprocurebhel.co.in/nicgep/app>) from the manufacturers (registered as well as unregistered) for the item 'Seals' as per details mentioned in **tender documents**.

The Offer shall be submitted on the designated E- Procurement portal only.

SPECIAL INSTRUCTIONS OF ENQUIRY-

1. All vendors to provide ***point wise reply/confirmation*** along with relevant supporting documents to each and every point of Pre-Qualification Requirement for all enquiry items. Non-compliance of these may lead to rejection of offer as these are essential condition for participating in tender enquiry.
2. Late delivery Penalty for Late Deliveries shall be applicable **@0.5% per week** or part thereof on the value of respective delayed supplies subject to **maximum of 10%** of the value of respective delayed supplies. If vendor doesn't confirm late delivery penalty clause in their offer, then it will be presumed to be acceptable. No further query will be entertained in this regard after opening of techno-commercial bid part-1.
 - a. Vendor Contract clause regarding **GST ITC and provision for E-Invoices w.e.f. 01.04.2021:** W.e.f. 01.04.2021, vendor (having turnover of more than ₹50 Cr) to ensure submission of E-Invoice.
 - b. It has been specified by the Govt. that it is mandatory to mention a **valid unique invoice Reference No.** (IRN) and QR code as generated from Govt. portal on a Tax Invoice. Based on such information, GST ITC as claimed by BHEL in GST Returns shall be matched with the corresponding details uploaded by supplier in E-Invoicing System.
 - c. In case the vendor /contractor delays or fails to provide all the documents as per the Purchase order / Work Order at the time of submitting Tax invoice to BHEL, any subsequent financial loss to BHEL on account of vendor/contractor shall be to vendor's / contractor's account. BHEL has further right to take necessary steps to protect its interest at the time of release of payment. This further requires inclusion of IRN and QR code on tax invoice as announced by Govt. of India w.e.f. 01.04.2021.
3. Procurement directly from Manufacturers/ suppliers shall be preferred. However, in case of submission of offer through agents including dealers/ traders/ distributors/ stockiest/ Channel partners etc. on behalf of manufacturer or the manufacturer themselves insists for making suppliers through their such agents only, following guidelines will be followed.
 - a. Either the agent could bid on behalf of the manufacturer / supplier or the manufacturer / supplier could bid directly but not both.
 - b. In case bids are received from both the manufacturer / supplier and the agent, the bid received from agent shall be ignored.
 - c. The agent shall not allow to represent more than one manufacturer / supplier in the same tender.

- d. Agent should submit the authorization letter from the manufacturer clearly indicating details like Name, e-mail and address of manufacturer and relationship with agent and its validity to be submitted with bid. The **authorization letter should be tender specific.**
- e. In case order is to be placed and executed by agent following aspects are to be ensured:
- Manufacturer of the agent should meet the PQR as defined in tender.
 - Agent should have annual turnover of at least equal to ₹ **05 Lacs** during one financial year and the net worth of the agent should be positive.
 - Manufacturer and bidder / agent should jointly confirm Guarantee for the quality of product and timely delivery as stipulated in the NIT.
4. Please submit your offer only for the above requirement subject to our **GENERAL INSTRUCTIONS AND STANDARD TERMS & CONDITIONS (GISTC: Version June-2021, Rev: 06)**. Please visit our site www.hwr.bhel.com for General Instructions and Standard Terms & Conditions (GISTC) for Tender Enquiries. All the bidders/vendors must ensure compliance of these GISTC. GISTC can also be referred by login to B2B Portal for Registered Vendors.
5. **Vendor to submit duly filled and signed Non-Disclosure Agreement (NDA; attached with tender documents) to get the drawings and specifications from BHEL. The dully filled NDA shall be submitted to following mail ids: kaushal@bhel.in; deepakkumar1@bhel.in.**

The tender documents can be downloaded from the web sites <https://eprocurebhel.co.in/nicgep/app/> / www.bhel.com / www.hwr.bhel.com.

“As per the OM No. F.No. 1(2)(1)/2016-MA dtd. 09.02.2017 issued from the Office of Development Commissioner (Micro, Small & Medium Enterprises), “Traders and agents should not be allowed to avail the benefits extended under the PP Policy.”

In view of this, it is clarified that benefits of MSE (such as EMD Waiver, Tender fee exemption, Price preference, Payment preference etc.) will be given only to those MSE Vendors who are manufacturers of offered items against the NIT. **No MSE benefits shall be provided to Agents / Stockists / Dealers / Traders etc. for the items offered but not manufactured by themselves.”**

For E-Payment, the RTGS details are mentioned as below:

| Bank Details | SWIFT Details of bank |
|---|--|
| STATE BANK OF INDIA RANIPUR BRANCH, OPP: BHEL MAIN GATE, SECTOR-5, RANIPUR, HARIDWAR, UTTRAKHAND, INDIA PIN CODE : 249403 | SWIFT NO: SBININBB225 CC ACCOUNT NO :10667995458 IFSC CODE : SBIN0000586 |

As per notification reference no. NSIC/HO/GP/15(4)/2013-14 dated 07.07.2013 Micro & Small Enterprises (MSEs) are not required to submit Tender fees. A Valid MSE certificate such as Udyog Aadhar (UAN) / Udyam Certificate/NSIC/EM (Part-II) as per GISTC shall be submitted in support of Micro & Small Enterprises (MSEs).

INSTRUCTIONS TO BIDDERS FOR SUBMITTING OFFER

DEFINITION:

Registered Vendors - Are those who are registered with BHEL, Haridwar for Megawatt rating/ Size/ Weight of tendered components in respective steel grade or machining of such items.

Un-registered Vendors - Are those who are not registered with BHEL, Haridwar for Megawatt rating/ Size/ Weight of tendered components in respective steel grade or machining of such items.

TECHNICAL QUALIFICATION: Technical Requirement, Pre-Qualifying Requirements/PQR & Drawings to be submitted. It is the mandatory requirement. Offer of vendors not meeting these requirements may not be considered.

ESSENTIAL INSTRUCTIONS

Un-registered vendors may be approved by BHEL, if found suitable, on the basis of data furnished by them in Supplier Registration Form (SRF) for Foreign Vendors or Indigenous Vendors (as applicable). Vendor Registration Form shall be filled only by unregistered vendors on our website www.bhel.com.

BHEL team may visit the vendor(s) works for verification of capability and capacity claimed in tender documents/offer(s).

Tender shall be **submitted in two parts** in separate cover as below on or before the due date (**23 Apr 2022**):

Part I (Cover-1) - Containing the following:

1. Point wise duly filled Pre-Qualifying Requirements as per tender document
2. Techno-commercial terms and conditions
3. MSME Certificate (If Applicable)
4. Self-Certification Certificate for MII, If applicable
5. Certificate required as per order no F.No.6/18/2019-PPD of department of Expenditure(DoE)

Part II (Cover-2) - Containing the following

1. Price Bid as per attached Annexure (Price Bid Format)

| Salient Details of Notice Inviting Tender (NIT) | | |
|---|---|--|
| Sl. No. | Issue | Description |
| 1. | Item details | As per Tender Document |
| | Issue of Tender Documents | From BHEL eProcurement website https://eprocurebhel.co.in/nicgep/app (Tender documents will be available for downloading from BHEL e-Procurement website till due date of submission) |
| | Due Date Of Offer Submission | 23-Apr-2022; Refer https://eprocurebhel.co.in/nicgep/app Offer to be submitted in online only through e-procurement Portal. (Bidders are requested to visit website to view corrigendum/ addenda/ amendments/ extension/ modification etc. before submitting offer). |
| | Opening of Tender (Techno-Commercial Bid, Part-1) | Refer https://eprocurebhel.co.in/nicgep/app This tender being an e-tender, it shall be opened online only through the E-Procurement Portal. Participating bidders may witness the Opening online only. |
| | Latest Updates | Latest updates on the important dates, Amendments, Correspondences, Corrigenda, Clarifications, Changes, Errata, Modifications, Revisions, etc to Tender Specifications will be hosted in BHEL e-tender portal https://eprocurebhel.co.in/nicgep/app and not in the newspapers. Bidders to keep themselves updated with all such information |

E-Procurement Portal Inputs

Procedure for Submission of Offer for E – Tender-Procedure for Submission of Tender is available in the “Bidder Manual for BHEL Bidders” at E-tender portal <https://eprocurebhel.co.in/nicgep/app> . Terms and conditions mentioned therein shall form integral part of the NIT and bidders shall abide by the same.

Hardware and Software requirements for participating in e-tender

Please refer website for minimum system requirements and setting document for Bidders under the link:
<https://eprocurebhel.co.in/nicgep/app>

Digital Signature

To know the procedure for obtaining Digital Signature Certificate (DSC), suppliers who are not having the DSC are advised to visit our website [http://www.bhel.com/home.php/Tender Notifications/Sample Checklist](http://www.bhel.com/home.php/Tender%20Notifications/Sample%20Checklist).

NIC portal Helpdesk Contacts

For any technical related queries please call at 24 x 7 Help Desk Number

0120-4001 002

0120-4200 462

0120-4001 005

0120-6277 787

International bidders are requested to prefix 91 as country code

Email Support

Address: A) For any Issues or Clarifications relating to the published tenders, bidders are requested to contact the respective Tender Inviting Authority

Technical - support-eproc@nic.in

Note

Offers/tenders submitted in the E-tender portal shall only be considered for further evaluation. Offers sent by FAX / E-mail / any mode other than E-tender would not be entertained and shall be out rightly rejected.

SPECIAL NOTE: All documents to be submitted should be uploaded in respective places in the E-Tender portal as per the list mentioned given in this NIT. BHEL shall not be responsible for in-complete documents.

Indent no. 20210756 rev. 00**Pre-Qualification requirements for "Chevron Packing" Material Code: HT4320022483**

Chevron Packing are used for sealing between piston Cylinder flange. These packing are sandwiched between Gland Ring & Bush.

1.0 Experience Requirement -

a- The Vendor should have experience of manufacturing, testing & supply of Packings. The vendor to confirm.

b- Further, the Vendor should be a regular manufacturer of Packing and vendor should have supplied at least five (5) nos. of Packing in last ten (10) years as on date of issuance of purchase enquiry with following minimum technical details:

| Si no. | Product features | Details |
|--------|--|---|
| 1. | Material | Chevron packing |
| 2. | Reinforcement fabric for Chevron Packing | Nylon (to resist water absorption & dimensional Change) |
| 3. | Working pressure | 100 Kg/cm ² or above |

c- In support of above, vendor to furnish information, in following format for previous supplied Packing meeting the above technical requirements (as per sl. no. 1.0-b)*

| Sl. No. | Name & address of customer | Contact Details of the customer (email & phone number etc.) | Purchase order reference no. | Purchase order issue date | Design material | Normal working pressure | Test pressure | Total Qty. (nos.) |
|---------|----------------------------|---|------------------------------|---------------------------|-----------------|-------------------------|---------------|-------------------|
| | | | | | | | | |
| | | | | | | | | |

* For the past Ten (10) years from the date of issuance of enquiry.

2.0 Vendor to submit the following documents as an evidence of acceptance of supplied Packing for the above mentioned successfully executed order:

- Copy of Un-Priced Purchase Orders executed in last ten (10) years from the date of issuance of enquiry.
- Material test certificate & Hydro test certificate of Packing for any one of the PO submitted. The submitted certificates should have co-relation with PO.
- Material acceptance certificate/dispatch documents against any one of the above P.O. The submitted certificates should have co-relation with PO.

Note:-

- Against vendor's replies, BHEL reserves the right to ask for more information/documents.
- Vendor's offer shall not be considered, if vendor fails to furnish the document/information and doesn't meet the acceptance criteria as mentioned above.
- In case information furnished by the vendor found false/incorrect, BHEL reserves the right to reject their offer.

| Prepared by | Reviewed Prepared by | Approved by |
|------------------------------------|------------------------------------|------------------------------------|
| <i>Dinesh Kumar</i> 21/07/2021 | <i>Dinesh Kumar</i> 21/07/2021 | <i>Lakhmi</i> 21/07/21 |
| Dinesh Kumar (Dy. Mgr / STE-TG) | Dinesh Kumar (Dy. Mgr / STE-TG) | Lakhmi Singh (Manager / STE-TG) |

Pre-Qualification requirements for "Piston Guide (Guide Strip KF)" Material Code: HT4320022491

Piston Guide (Guide Strip KF) is used for sealing between piston & Cylinder.

1.0 Experience Requirement -

a- The Vendor should have experience of manufacturing, testing & supply of **Non-metallic (PTFE Bronze) seals**. The vendor to confirm.

b- Further, the Vendor should be a regular manufacturer of **Non-metallic (PTFE Bronze) seals** and Vendor should have supplied at least five (5) nos. of **Non-metallic (PTFE Bronze) seals** in last ten (10) years as on date of issuance of purchase enquiry with following minimum technical details:

| Si no. | Product features | Details |
|--------|------------------|----------------------------------|
| 1. | Material | Non-metallic (PTFE Bronze) seals |
| 2. | Working pressure | 100 Kg/cm ² or above |
| 3. | Test pressure | 150 Kg/cm ² or above |

c- In support of above, vendor to furnish information, in following format for previous supplied **Non-metallic (PTFE Bronze) seals** meeting the above technical requirements (as per sl. no. 1.0-b)*

| Sl. No. | Name & address of customer | Contact Details of the customer (email & phone number etc.) | Purchase order reference no. | Purchase order issue date | Design material | Normal working pressure | Test pressure | Total Qty. (nos.) |
|---------|----------------------------|---|------------------------------|---------------------------|-----------------|-------------------------|---------------|-------------------|
| | | | | | | | | |
| | | | | | | | | |

*For the past Ten (10) years from the date of issuance of enquiry.

2.0 Vendor to submit the following documents as an evidence of acceptance of supplied **Non-metallic (PTFE Bronze) seals** for the above mentioned successfully executed order:

- Copy of Un-Priced Purchase Orders executed in last ten (10) years from the date of issuance of enquiry.
- Material test certificate & Hydro test certificate of **Non-metallic (PTFE Bronze) seals** for any one of the PO submitted. The submitted certificates should have co-relation with PO.
- Material acceptance certificate/dispatch documents against any one of the above P.O. The submitted certificates should have co-relation with PO.

Note:-

- Against vendor's replies, BHEL reserves the right to ask for more information/documents.
- Vendor's offer shall not be considered, if vendor fails to furnish the document/information and doesn't meet the acceptance criteria as mentioned above.
- In case information furnished by the vendor found false/incorrect, BHEL reserves the right to reject their offer.

| Prepared by | Reviewed by | Approved by |
|------------------------------------|------------------------------------|-------------------------------------|
| <i>Dinesh Kumar</i> 21/07/2021 | <i>Dinesh Kumar</i> 21/07/2021 | <i>Lakshmi</i> 21/07/21 |
| Dinesh Kumar (Dy. Mgr / STE-TG) | Dinesh Kumar (Dy. Mgr / STE-TG) | Lakshmi Singh (Manager / STE-TG) |

Indent no. 20210756 rev. 00**Pre-Qualification requirements for "Piston Seal" Material Code: HT4320022505**

30

Piston seal is used for sealing between piston & Cylinder.

1.0 Experience Requirement -

a- The Vendor should have experience of manufacturing, testing & supply of **Seals (two-piece seal set consisting of one PTFE bronze profile ring and one O-Ring (Nitrile rubber NBR))**. The vendor to confirm.

b- Further, the Vendor should be a regular manufacturer of **Seals (two-piece seal set consisting of one PTFE bronze profile ring and one O-Ring (Nitrile rubber NBR))** and Vendor should have supplied at least five (5) nos. of **Seals (two-piece seal set consisting of one PTFE bronze profile ring and one O-Ring (Nitrile rubber NBR))** in last ten (10) years as on date of issuance of purchase enquiry with following minimum technical details:

| Sl no. | Product features | Details |
|--------|------------------|--|
| 1. | Material | Piston seal, two piece seal set consisting of one PTFE bronze profile ring and one O-Ring (Nitrile rubber NBR) |
| 2. | Working pressure | 100 Kg/cm ² or above |
| 3. | Test pressure | 150 Kg/cm ² or above |

c- In support of above, vendor to furnish information, in following format for previous supplied **Seals (two-piece seal set consisting of one PTFE bronze profile ring and one O-Ring (Nitrile rubber NBR))** meeting the above technical requirements (as per sl. no. 1.0-b)*

| Sl. No. | Name & address of customer | Contact Details of the customer (email & phone number etc.) | Purchase order reference no. | Purchase order issue date | Design material | Normal working pressure | Test pressure | Total Qty. (nos.) |
|---------|----------------------------|---|------------------------------|---------------------------|-----------------|-------------------------|---------------|-------------------|
| | | | | | | | | |
| | | | | | | | | |

* for the past Ten (10) years from the date of issuance of enquiry.

2.0 Vendor to submit the following documents as an evidence of acceptance of supplied **Seals (two piece seal set consisting of one PTFE bronze profile ring and one O-Ring (Nitrile rubber NBR))** for the above mentioned successfully executed order:

- Copy of Un-Priced Purchase Orders executed in last ten (10) years from the date of issuance of enquiry.
- Material test certificate & Hydro test certificate of **Seals (two piece seal set consisting of one PTFE bronze profile ring and one O-Ring (Nitrile rubber NBR))** for any one of the PO submitted. The submitted certificates should have co-relation with PO.
- Material acceptance certificate/dispatch documents against any one of the above P.O. The submitted certificates should have co-relation with PO.

Note:-

- Against vendor's replies, BHEL reserves the right to ask for more information/documents.
- Vendor's offer shall not be considered, if vendor fails to furnish the document/information and doesn't meet the acceptance criteria as mentioned above.
- In case information furnished by the vendor found false/incorrect, BHEL reserves the right to reject their offer.

| Prepared by | Reviewed by | Approved by |
|------------------------------------|------------------------------------|------------------------------------|
| <i>Dinesh Kumar</i> 21/07/2021 | <i>Dinesh Kumar</i> 21/07/2021 | <i>Lakhmi</i> 21/07/21 |
| Dinesh Kumar (Dy. Mgr / STE-TG) | Dinesh Kumar (Dy. Mgr / STE-TG) | Lakhmi Singh (Manager / STE-TG) |

Pre-Qualification requirements for "Seal (Acrylo-Nitrile Butadiene rubber)" Material Code: HT4362019111

Item sketch (Typical):

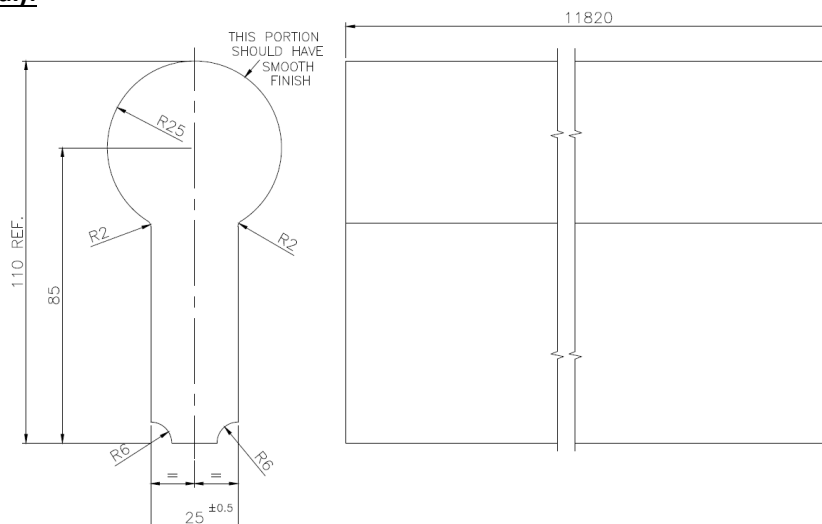

1.0 Experience Requirement -

a- The Vendor should have experience of manufacturing, testing & supply of **Seal (Acrylo-Nitrile Butadiene rubber)**. The vendor to confirm.

b- Further, the Vendor should be a regular manufacturer of **Seal (Acrylo-Nitrile Butadiene rubber)** and Vendor should have supplied at least five (5) nos. of **Seal (Acrylo-Nitrile Butadiene rubber)** in last ten (10) years as on date of issuance of purchase enquiry with following minimum technical details:

| Sl. no. | Product features | Details |
|---------|------------------|----------------------------------|
| 1. | Material | Acrylo-Nitrile Butadiene rubber |
| 2. | Working media | River water |
| 3. | Working pressure | 16.5 kg/cm ² or above |
| 4. | Test Pressure | 28 kg/cm ² or above |

c- In support of above, vendor to furnish information, in following format for previous supplied **Seal (Acrylo-Nitrile Butadiene rubber)** meeting the above technical requirements (as per sl. no. 1.0-b) for the past Ten (10) years from the date of issuance of enquiry.

| Sl. No. | Name & address of customer | Contact Details of the customer (email & phone number etc.) | Purchase order reference no. | Purchase order issue date | Material | Normal working pressure | Test pressure | Total Qty. (nos.) |
|---------|----------------------------|---|------------------------------|---------------------------|----------|-------------------------|---------------|-------------------|
| | | | | | | | | |
| | | | | | | | | |

2.0 Vendor to submit the following documents as an evidence of acceptance of supplied **Seal (Acrylo-Nitrile Butadiene rubber)** for the above mentioned successfully executed order:

- a) Copy of Un-Priced Purchase Orders executed in last ten (10) years from the date of issuance of purchase enquiry.
- b) Material test certificate & Hydro test certificate of Seal (Acrylo-Nitrile Butadiene rubber) for any one of the PO submitted. The submitted certificates should have co-relation with PO.
- c) Material acceptance certificate/dispatch documents against any one of the above P.O. The submitted certificates should have co-relation with PO.

Note:-

1. Against vendor's replies, BHEL reserves the right to ask for more information/documents.
2. Vendor's offer shall not be considered, if vendor fails to furnish the document/information and doesn't meet the acceptance criteria as mentioned above.
3. In case information furnished by the vendor found false/incorrect, BHEL reserves the right to reject their offer.

| Prepared by | Reviewed by | Approved by |
|--|--|-----------------------------------|
| <i>Susheel</i> 12.07.21 | <i>Susheel</i> 12.07.21 | <i>Lakhmi</i> 17/07/21 |
| Susheel Kothiyal (Dy. Mgr / STE-TG) | Susheel Kothiyal (Dy. Mgr / STE-TG) | Lakhmi Singh (Manager/ STE-TG) |

Pre-Qualification requirements for “Seal (Acrylo-Nitrile rubber)” Material Code: HT4362019154, HT4362019162, HT4362019170

Item sketch (Typical):

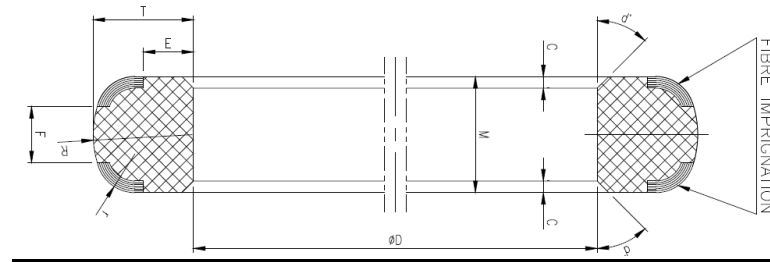

1.0 Experience Requirement -

a- The Vendor should have experience of manufacturing, testing & supply of **Seal (Acrylo-Nitrile rubber)**. The vendor to confirm.

b- Further, the Vendor should be a regular manufacturer of **Seal (Acrylo-Nitrile rubber)** and Vendor should have supplied at least five (5) nos. of **Seal (Acrylo-Nitrile rubber)** in last ten (10) years as on date of issuance of purchase enquiry with following minimum technical details:

| Si no. | Product features | Details |
|--------|------------------|----------------------------------|
| 1. | Material | Acrylo-Nitrile rubber |
| 2. | Working media | River water |
| 3. | Working pressure | 16.5 kg/cm ² or above |
| 4. | Test Pressure | 28 kg/cm ² or above |

c- In support of above, vendor to furnish information, in following format for previous supplied **Seal (Acrylo-Nitrile rubber)** meeting the above technical requirements (as per sl. no. 1.0-b) for the past Ten (10) years from the date of issuance of enquiry.

| Sl. No. | Name & address of customer | Contact Details of the customer (email & phone number etc.) | Purchase order reference no. | Purchase order issue date | Material | Normal working pressure | Test pressure | Total Qty. (nos.) |
|---------|----------------------------|---|------------------------------|---------------------------|----------|-------------------------|---------------|-------------------|
| | | | | | | | | |
| | | | | | | | | |

2.0 Vendor to submit the following documents as an evidence of acceptance of supplied Seal (Acrylo-Nitrile rubber) for the above mentioned successfully executed order:

- a) Copy of Un-Priced Purchase Orders executed in last ten (10) years from the date of issuance of purchase enquiry.
- b) Material test certificate & Hydro test certificate of **Seal (Acrylo-Nitrile rubber)** for any one of the PO submitted. The submitted certificates should have co-relation with PO.
- c) Material acceptance certificate/dispatch documents against any one of the above P.O. The submitted certificates should have co-relation with PO.

Note:-

1. Against vendor's replies, BHEL reserves the right to ask for more information/documents.
2. Vendor's offer shall not be considered, if vendor fails to furnish the document/information and doesn't meet the acceptance criteria as mentioned above.
3. In case information furnished by the vendor found false/incorrect, BHEL reserves the right to reject their offer.

| Prepared by | Reviewed by | Approved by |
|---|---|------------------------------------|
| <i>Susheel</i> <i>12.07/21</i> | <i>Susheel</i> <i>12.07/21</i> | <i>Lakshmi</i> <i>12/07/21</i> |
| Susheel Kothiyal (Dy. Mgr. / STE-TG) | Susheel Kothiyal (Dy. Mgr. / STE-TG) | Lakshmi Singh (Manager/ STE-TG) |

Pre-Qualification requirements for “Seal (PTFE or Polyurethane or Rubber)” Material Code: HT4362019138

Item sketch (Typical):

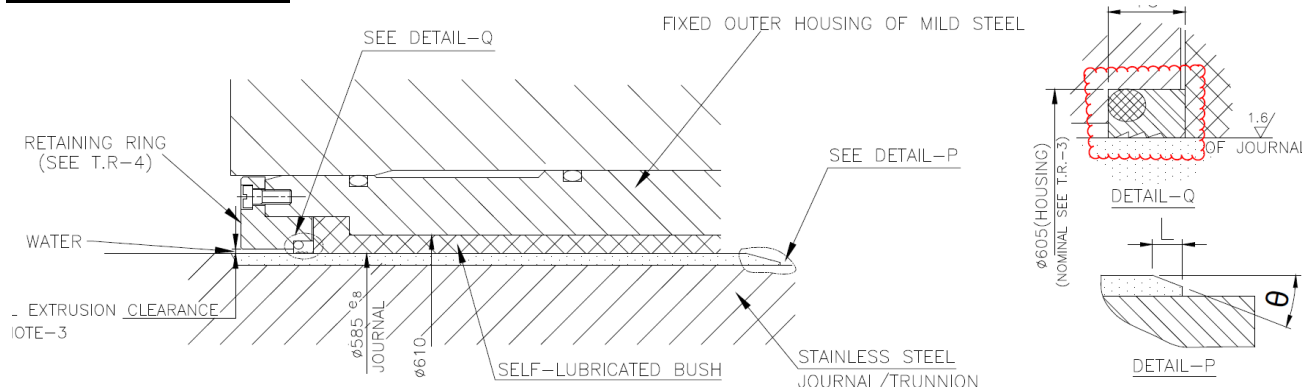

1.0 Experience Requirement -

a- The Vendor should have experience of manufacturing, testing & supply of **Seal (PTFE or Polyurethane or Rubber)**. The vendor to confirm.

b- Further, the Vendor should be a regular manufacturer of **Seal (PTFE or Polyurethane or Rubber)** and Vendor should have supplied at least five (5) nos. of **Seal (PTFE or Polyurethane or Rubber)** in last ten (10) years as on date of issuance of purchase enquiry with following minimum technical details:

| Sl. no. | Product features | Details |
|---------|-------------------------|--------------------------------|
| 1. | Material | PTFE or Polyurethane or Rubber |
| 2. | Normal working pressure | 16.5 bar or above |
| 3. | Test Pressure | 28 bar or above |

c- In support of above, vendor to furnish information, in following format for previous supplied **Seal (PTFE or Polyurethane or Rubber)** meeting the above technical requirements (as per sl. no. 1.0-b) for the past Ten (10) years from the date of issuance of enquiry.

| Sl. No. | Name & address of customer | Contact Details of the customer (email & phone number etc.) | Purchase order reference no. | Purchase order issue date | Material | Normal working pressure | Test pressure | Total Qty. (nos.) |
|---------|----------------------------|---|------------------------------|---------------------------|----------|-------------------------|---------------|-------------------|
| | | | | | | | | |
| | | | | | | | | |

2.0 Vendor to submit the following documents as an evidence of acceptance of supplied **Seal (PTFE or Polyurethane or Rubber) for the above mentioned successfully executed order:**

- a) Copy of Un-Priced Purchase Orders executed in last ten (10) years from the date of issuance of purchase enquiry.
- b) Material test certificate & Hydro test certificate of **Seal (PTFE or Polyurethane or Rubber)** for any one of the PO submitted. The submitted certificates should have co-relation with PO.
- c) Material acceptance certificate/dispatch documents against any one of the above P.O. The submitted certificates should have co-relation with PO.

Note:-

1. Against vendor's replies, BHEL reserves the right to ask for more information/documents.
2. Vendor's offer shall not be considered, if vendor fails to furnish the document/information and doesn't meet the acceptance criteria as mentioned above.
3. In case information furnished by the vendor found false/incorrect, BHEL reserves the right to reject their offer.

| Prepared by | Reviewed by | Approved by |
|---|---|-----------------------------------|
| <i>Susheel</i> 12.07.21 | <i>Susheel</i> 12.07.21 | <i>Lakshmi</i> 12.07.21 |
| Susheel Kothiyal (Dy. Mgr. / STE-TE) | Susheel Kothiyal (Dy. Mgr. / STE-TE) | Lakshmi Singh (Manager/STE-TG) |

Mandatory Pre-Qualification requirements for Cup Seal**Material Code: HT4362019103****Description**

Cup Seals are used for sealing in hydraulic devices of reciprocating motion, operating upto certain pressure & temperature range.

Mandatory requirement for Pre-Qualification:

| Sl. No. | Pre-qualification requirements | Vendor response | | | | | | | | | | | | | | | | | | | | | | | | | | | | | | | | | | | | |
|---------|--|---|------------------------------|---|------------------------------|---------------------------|--------------------|-------------------|--------------------|-------------------|--|--|--|--|--|--|--|--|--|--|--|--|--|--|--|--|--|--|--|--|--|--|--|--|--|--|--|--------|
| 1.0 | <p>The Vendor should be a regular manufacturer of Cup Seal and Vendor should have supplied at least five (5) Nos of Cup Seal in last five (5) years (from the date of enquiry) with following technical details:</p> <p>a. Material: Acrylonitrile rubber b. Operating pressure: Upto 320 kgf/cm² c. Operating temperature: -35° C to 80° C</p> <p>In support of experience at sl. 1, vendor to furnish information, in following format for previously supplied Cup Seal for at least two Purchase orders meeting the above technical requirement:-</p> <table border="1"> <thead> <tr> <th>Sl. No.</th> <th>Name & address of customer</th> <th>Contact Details of the customer (email & phone number etc.)</th> <th>Purchase order reference no.</th> <th>Purchase order issue date</th> <th>material</th> <th>Design pressure</th> <th>Design temperature</th> <th>Total Qty. (nos.)</th> </tr> </thead> <tbody> <tr> <td></td> <td></td> <td></td> <td></td> <td></td> <td></td> <td></td> <td></td> <td></td> </tr> <tr> <td></td> <td></td> <td></td> <td></td> <td></td> <td></td> <td></td> <td></td> <td></td> </tr> <tr> <td></td> <td></td> <td></td> <td></td> <td></td> <td></td> <td></td> <td></td> <td></td> </tr> </tbody> </table> | Sl. No. | Name & address of customer | Contact Details of the customer (email & phone number etc.) | Purchase order reference no. | Purchase order issue date | material | Design pressure | Design temperature | Total Qty. (nos.) | | | | | | | | | | | | | | | | | | | | | | | | | | | | Yes/No |
| Sl. No. | Name & address of customer | Contact Details of the customer (email & phone number etc.) | Purchase order reference no. | Purchase order issue date | material | Design pressure | Design temperature | Total Qty. (nos.) | | | | | | | | | | | | | | | | | | | | | | | | | | | | | | |
| | | | | | | | | | | | | | | | | | | | | | | | | | | | | | | | | | | | | | | |
| | | | | | | | | | | | | | | | | | | | | | | | | | | | | | | | | | | | | | | |
| | | | | | | | | | | | | | | | | | | | | | | | | | | | | | | | | | | | | | | |
| 2.0 | <p>The vendor to submit the following documents as an evidence of acceptance of supplied Cup Seal for the above mentioned successfully executed order -</p> <p>a. Copy of Un-Priced Purchase Orders executed in last five (5) years from date of issuance of enquiry. b. Material test certificate for Cup seal for any one of the PO submitted. The submitted test certificates should have co-relation with PO. c. Acceptance certificate/dispatch document for any one of the submitted PO.</p> | Documents enclosed : Yes /No | | | | | | | | | | | | | | | | | | | | | | | | | | | | | | | | | | | | |

Notes:

- Against vendor's replies, BHEL reserves the right to ask for more information / documents/clarifications.
- Vendor's offer shall not be considered if vendor fails to furnish the document / information / clarifications as mentioned above or vendor doesn't meet the acceptance criteria (mentioned above from sl. no. 1 to 2).
- In case information furnished by the vendor found false/incorrect, BHEL reserves the right to reject their offer.

| | | |
|-------------|---------------|-------------------------------|
| Prepared By | Leelpat Singh | <i>Leelpat Singh</i> 16.7.21 |
| Reviewed By | Leelpat Singh | <i>Leelpat Singh</i> 16.7.21 |
| Approved By | Nawnit Nirala | <i>Nawnit Nirala</i> 16/07/21 |

NON-DISCLOSURE AND PROPRIETARY INFORMATION AGREEMENT

BETWEEN

_____ (**Name of the Vendor**), having its registered offices in _____ (**Address of Vendor**), registered under the no. _____ of the Companies' register of _____ (**Name of Place and Country**), capital stock of _____ (**Value**), with a place of business in _____ (**Name of Place and Country**) (hereinafter referred to as " _____ (**Name of Vendor**)" which expression shall unless repugnant to the context shall include its successors & assigns.

AND

Bharat Heavy Electricals Ltd a company incorporated under the Indian Companies Act 1956 having its registered offices at BHEL House, Siri Fort, New Delhi -110 049 and having one of its works at Heavy Electrical Equipment Plant, Ranipur, Haridwar-249403 (Uttarakhand), India registered under the No. 4281 of 1964-65 of the companies register of Delhi, capital stock of Rs 4895.2 million with a place of registered office in New Delhi (hereinafter referred to as "BHEL") which expression shall unless repugnant to the context shall include its successors & assigns. hereinafter also referred to individually as "the Party" or collectively as "the Parties".

BACKGROUND

This Agreement sets forth the rights and obligations of the Parties with respect to the use, handling, protection and safeguarding of Proprietary Information that is disclosed by and between the Parties.

WHEREAS

A) the Parties wish to pursue exploratory discussions concerning a possible collaboration between them in relation to the Tender Enquiry No..... also mentioned in Exhibit 1;

B) It is anticipated that during the possible discussions it may be necessary for BHEL to share certain confidential and proprietary information in written, oral, visual and/or physical/sample/ form to the other party (collectively "**Proprietary Information**", more fully detailed in clause 1 herein below) for the purpose of enabling the parties to interact and deliberate the aforementioned order and take it further (hereinafter referred to as "**Purpose**")

The parties desire to protect such Proprietary Information and ensure that it is not disclosed to any third party without the permission of the party disclosing such Proprietary Information;

NOW, THEREFORE, the Parties have agreed as follows:

1. The term “Proprietary Information” shall mean any information or data of whatsoever kind of a confidential or proprietary nature disclosed by BHEL (hereinafter called the “Disclosing Party”) to the vendor) hereinafter called the “Receiving Party”), including but not limited to, commercial information, knowhow and technical information in the form of designs, drawings, concepts, requirements, specifications, trade secrets, IPR, brand name, marketing plans & all other non-public information, software, interfaces, components, processes, or the like, that have been or will be disclosed by the Disclosing Party to the Receiving Party pursuant to this Agreement, either in writing, orally or other form, which is designated as “Proprietary” or “Confidential” by the Disclosing Party by means of formal declaration or an appropriate stamp, legend or any other written or orally notice . Notwithstanding anything to the contrary contained hereinabove, all the drawings and other technical information shared regarding the above mentioned order by the Disclosing Party shall be considered Proprietary Information with or without being marked as confidential/proprietary at the time of sharing the same.

2. Proprietary Information may be conveyed, without limitation, through any written or printed documents, samples, models, electronic form on disk, tape, other storage media or any other means of disclosing such Proprietary Information that Disclosing Party may elect to use during the life of this Agreement, but if Disclosing Party originally discloses information orally or visually, the Receiving Party will protect such information as Proprietary Information to the extent that the Disclosing Party :

- identifies the Information as Proprietary at the time of original disclosure,
- summarizes the Proprietary Information in writing.

Information stored in electronic form on disk, tape, other storage media will be adequately marked if a proprietary legend displays when the information originally runs on a computer system and when the information is printed from its data file. Proprietary Information also includes any information which can be obtained by examination, testing or analysis of any hardware or material substance or any component part of such hardware or material substance provided by the Disclosing Party even though the requirements in Clause 1 for marking and designation have not been fulfilled.

3. The Disclosing Party, to the extent of its rights to do so, shall disclose to the other only the Proprietary Information which the Disclosing Party deems appropriate to fulfil the objectives of this Agreement. The Parties hereby represent that the disclosure of Proprietary Information by and between themselves shall be made in compliance with, and subject to the Indian laws and regulations.

4. The Receiving Party hereby agrees and covenants that, from the effective date of this Agreement until the expiry date as per article 11 and the following period as per article 12, the Proprietary Information that it receives from the Disclosing Party shall:

- a) be protected and kept in strict confidence by the Receiving Party which must use the same degree of care it uses to protect its own confidential information and in no case less than a reasonable care;
- b) be only disclosed to and used by those persons within the Receiving Party's organization who have a need to know and solely for the purposes specified in this Agreement, and be treated by such persons or entities with the same degree of care and subject to the same restrictions;
- c) to procure that each third party to whom Proprietary Information is disclosed under this Agreement is made aware of the provisions of this Agreement prior to such disclosure to it and that each such third party is bound by obligations of confidentiality which are no less onerous than those contained in this Agreement;
- d) neither be disclosed nor caused to be disclosed or made available, either directly or indirectly, to any third Party or persons other than those mentioned in subparagraph b) above or other persons upon which both of the contractual Parties shall agree in an amendment to this Agreement;
- e) not to reverse engineer, disassemble or decompile any prototypes, software or other tangible objects which embody the Proprietary Information and which are provided to the Receiving Party hereunder;
- f) not to copy, reproduce or reduce to writing any part of such Proprietary Information except as may be reasonably necessary for the purpose referred to in the Recitals of this Agreement

PROVIDED THAT the Receiving Party shall be entitled to make any disclosure required by court order or government or regulatory requirement of the Disclosing Party's Proprietary Information subject to notifying the Disclosing Party as soon as possible of such requirement.

5. Any Proprietary Information and copies thereof disclosed by the Disclosing Party to the other shall remain the property of the Disclosing Party and shall be immediately returned or destroyed by the Receiving Party upon request or upon expiry of this Agreement.

6. The Receiving Party shall have no obligations or restrictions with respect to any Proprietary Information for which the Receiving Party can prove that:

- a) is in or which comes into the public domain otherwise than as a result of a breach of this Agreement by any person to whom a disclosure of Proprietary Information is made as permitted under this Agreement or of any other duty of confidentiality relating to the Proprietary Information of which the Receiving Party has knowledge; or
- b) it has been in its possession without restriction at the time of the disclosure, as evidenced by written documentation in its files; or
- c) it has been lawfully received from a third Party without breach of this Agreement; or
- d) it has been or is published without violation of this Agreement; or
- e) disclosure of such proprietary information is required by Law or by a court of competent jurisdiction.

7. With respect to any exchange of Proprietary Information which may occur as a result of this Agreement, it is expressly understood and agreed that the persons listed in Exhibit 2 shall, on behalf of the respective Parties, be the exclusive individuals authorized to receive from and transmit to the other Party Proprietary Information under this Agreement. Each Party may replace at any time its respective authorized individuals identified in such Exhibit 2, within its own organization. Any such new designation by a Party shall be made by written notice to the other at the address indicated in such Exhibit 2.
8. Any Proprietary Information which is identified as "Classified Information", or whose export is subject to an export license, shall be identified as such by the Disclosing Party at the time of disclosure and the disclosure, protection, use and handling thereof, shall remain subject to the security procedures and restrictions imposed by the Disclosing Party's Government.
9. The disclosure of Proprietary Information under this Agreement by the Disclosing Party to the Receiving Party shall not be construed as granting to the Receiving Party any right, whether express or implied by licence or otherwise, on the matters, inventions or discoveries to which such information pertains, or as granting any trademark, patents, copyrights, trade secret right or other form of intellectual property right.
10. This Agreement covers the exchange of Proprietary Information which may be made by the Disclosing Party to the Receiving Party until ten years from signing of the agreement or any extension thereto which may be agreed upon by the Parties in writing. Proprietary information relevant to the Program detailed in Exhibit 1, already made available to the Receiving Party before the effective date, shall also be protected under this Agreement.

It is understood by the parties that, prior to disclosure, the Disclosing Party shall have obtained any government authorisation needed for the export of the Proprietary Information

11. The expiry of the period contemplated in Article 10 of this Agreement shall not relieve the Receiving Party from complying with the obligations imposed by Article 4 here above with respect to the use and protection of the Proprietary Information, received prior the date of such expiry, for a period of ten (10) years after such expiry.
12. The Parties are independent contractors. Each will bear all costs and expenses in connection with this Agreement. This Agreement is intended to facilitate only the exchange of Proprietary Information in connection with the contract entered between both the parties and is not intended to be, and shall not be construed to create a teaming agreement, joint venture, association, partnership, or other business organisation or agency arrangement and no Party shall have the authority to bind the other without the other Party's separate prior written agreement.

13. The Receiving Party shall indemnify the Disclosing Party for all costs, expenses or damages that Disclosing Party incurs as a result of any violation of any provisions of this Agreement. This obligation shall include court, litigation expenses, and actual, reasonable attorney's fees. The Receiving Party also agrees that monetary damages may be inadequate compensation to the Disclosing Party in the event the Receiving Party breaches any provision of this Agreement. Therefore, the parties agree that in the event of a breach or threatened breach of confidentiality, the Disclosing Party shall also be entitled to specific performance and injunctive or other equitable relief as a remedy for any such breach or anticipated breach.

14. This Agreement shall be governed by and shall be interpreted in accordance with the substantive Indian laws. Irrespective of the foregoing each Party shall remain bound by the provisions of its own national laws and regulations with respect to the transfer or use of Classified Information or information whose export is subject to an export license.

15. All disputes among the Parties, in connection with or arising out of the existence, validity, construction, performance and termination of this Agreement (or any terms thereof), which the Parties are unable to resolve among themselves, shall be finally settled by an Arbitration as per the Arbitration & Conciliation Act, 1996. The Arbitration shall be held in Haridwar (India), in English language, in accordance with the rules laid down in the Arbitration and Conciliation act of India 1996, of a sole arbitrator mutually appointed by both the parties. The courts of Haridwar shall have exclusive jurisdiction.

16. The foregoing constitutes the entire Agreement among the Parties with respect to the subject matter hereof and supersedes and cancels all prior representations, negotiations, commitments, undertakings, communications, either oral or written, acceptances, understandings and agreements among the Parties with respect to or in connection with any of the matters to which such Agreement applies or refers.

17. Notices to _____ (**Name of Vendor**) shall be made at the following address:

(Complete Address of Vendor)

Attention: Mr. _____ (**Name of the Authorised Person of Vendor**)

Notices to BHEL shall be made at the following address:

BHARAT HEAVY ELECTRICALS LIMITED,
HEAVY ELECTRICAL EQUIPMENT PLANT,
Ranipur, Haridwar-249403 (Uttarakhand), India]

Attention:

(Name of the PPX Incharge)

18. The effective date of this Agreement shall be the date of the last signature appearing herein.

IN WITNESS WHEREOF, each of the Parties has caused this Agreement, to be executed by its duly authorized officer.

Date :

Signed for and on behalf of
(Name of Vendor)

By:

Title:

Signature:

Signed for and on behalf of
BHEL

By:

Title:

Signature:

19. No failure or delay by either party in exercising or enforcing any right, remedy or power here under shall operate as a waiver hereof.

20. In the event that any provision of this Agreement shall be held by a court of competent jurisdiction to be unenforceable, the remaining portion hereof shall remain in full force & effect.

EXHIBIT 1

to the

NON-DISCLOSURE AGREEMENT

between

_____ **(Name of Vendor)** and
BHARAT HEAVY ELECTRICALS LIMITED

dated:

The Non Disclosure Agreement covers the exchange of Proprietary Information which may occur during the discussions and negotiations in view of a possible cooperation between the Parties in the following programs:

-Description of Material or Servicesfor which the Enquiry issued
/ Purchase order to be placed

_____ **(Name of Vendor)** list of products that require an exchange of Proprietary Information which may be occur during the discussions and negotiations in view of a possible cooperation for the above programs :

EXHIBIT 2

to the
NON-DISCLOSURE AGREEMENT
between
_____ (**Name of Vendor**) and
Bharat Heavy Electricals Ltd.

dated:

Personnel of the Parties authorized to receive and/or transmit Proprietary Information under this Agreement:

For (**Name of Vendor**)
(**Name of Person**)

Tel.

Fax

Address.

For Bharat Heavy Electricals Ltd.

Mr.

Tel. 01334

Fax 01334

Address. Main Administration Building
BHEL, HEEP, Haridwar
India

Mr.

Tel.

Tel. 01334

Fax

Fax 01334

Address.

Address. Main Administration Building
BHEL, HEEP, Haridwar
India

Self-certification

As per Government Public procurement order no. P-45021/2/2017-BE-II dt.15.06.2017 & P-45021/2/2017-PP(BE-II) dated 28.05.2018,29.5.2019 & 04.6.2020, it is hereby certifying that we

.....

(supplier name) are(Class-I/Class-II) local supplier and will meet the requirement of minimum local content of (50%/20%) as defined in public procurement order dated 04.6.2020 for material against Enquiry no.

.....

Details of location at which local value addition will be made is as follows: -

.....

.....

We also understand, false declarations will be in breach of the code of integrity under Rule 175(1)(i)(h) of the General Financial Rules for which a bidder or its successors can be debarred for up to two years as per Rule 151 (iii) of the general financial rules along with such other actions as may be permissible under law.

Seal & Signature of Supplier

ANNEXURE: CERTIFICATE REQUIRED AS PER ORDER NO F.No.6182019-PPD UNDER RULE 144(XI) OF GENERAL FINANCIAL RULES (GFRS) 2017

ON COMPANY LETTER HEAD

Date -

CERTIFICATE REQUIRED AS PER ORDER NO F.No.6182019-PPD UNDER RULE 144(XI) OF GENERAL FINANCIAL RULES (GFRS) 2017

To,
M/s Bharat Heavy Electricals Ltd.
Heavy Electrical Equipment Plant
Haridwar – 249403

Ref:
Tender No. –

I have read the clauses regarding restrictions on procurement from a bidder of a country which shares a land border with India; I certify that bidder (.....) is not from such a country or, if from such a country, has been registered with the competent authority. I hereby certify that bidder (.....) fulfils all requirements in this regard and is eligible to be considered. (Where applicable, evidence of valid registration by the competent authority shall be attached).

Authorized