



BHEL GOINDWAL

TERMS AND CONDITIONS FOR
(Tender Enquiry No.1213-096 Dated 03.10.2012)

PRE-QUALIFICATION TERMS

P1 Bidders should primarily be engaged in manufacturing/supplying of Cable Gland. **Stockists, dealers will have to submit authorization certificate from their manufacturers'.**

Bidders to clearly mention/specify the infrastructure available with him for intended operations. If any operation (full or part) is further sub-contracted, the same should be clearly mentioned in the pre-qualification itself with detail of extent of operations proposed to be sub-contracted and details of subcontractors. BHEL may carry out evaluation of bidder's capability.

BHEL reserves the right to accept/reject any offer based on evaluation of bidder's capability. For verification of data presented for pre-qualification, BHEL may decide to visit the bidder(s) works.

Any fact found deviating from bids/as mentioned during evaluation shall make the bidder liable to be dis-qualified.

DUE DATE OF OPENING: 24.10.2012

1. INVITING TENDERS

Sealed tenders in two parts; Part I: Techno-commercial bid and Part-II: Price bid are hereby invited as per applicable standards mentioned by BHEL. The relevant documents are attached with the Enquiry.

The two bids should be submitted in **separate sealed inner envelopes** duly mentioning the detail as follows:

Bid	Description	Superscription on envelope	Min documents to be submitted
Part-I	Techno-Commercial bid	Part-I (Techno-Commercial) bid against tender enquiry no:1213-096 dated 03.10.2012 due for opening on 24.10.2012	1. Acceptance of all terms and conditions. 2. Un-priced (Prices not filled) format showing taxes and duties structure.
Part-II	Price bid	Part-II (Price) bid against tender enquiry No: 1213-096 Dated: 03.10.2012	No Other format shall be used for submitting the price bid. Any variation in Unit of Supply other than that mentioned in the Price bid format shall not be accepted. Rates should be mentioned in words as well as in figures. In case of any confusion rates in words shall be considered final. Anything other than price mentioned in the price bid shall be considered invalid.

PLEASE SEE AND FOLLOW THE CHECKLIST PROVIDED AT THE END

Manmeet Kumar



TERMS AND CONDITIONS FOR
(Tender Enquiry No.1213-096 Dated 03.10.2012)

All the sealed envelopes should be put in an outer envelope clearly mentioning Tender Enquiry No., item description as "Cable Gland" and due date of opening.

Part-I: Techno-Commercial bid should contain

- a) The details/data/ information/ supporting documents as per requirement of Pre-Qualification.
- b) Acceptance of Techno-Commercial terms and conditions should be attached next. This can be attached either by signing each page of terms and conditions or a confirmation statement.
Any deviation proposed by bidder shall be considered by BHEL at its own discretion; and if finally considered, shall carry loading factor at the discretion of BHEL.
- c) Unpriced price bid, filling all other details **except unit price**.

Part II: Price Bids:

Price quotation format shall be as attached.

The comparison among bidders shall be done on the basis of quoted rates converted to "Total landed cost to BHEL". Duties shall be payable extra against ED Gate Pass valid for CENVAT benefit.

Price quoted shall be firm and not subject to any escalation during the PO execution.

Price should be quoted on FOR Destination Goindwal Sahib basis. If not mentioned, it shall be concluded that the offer is on FOR Destination Goindwal Sahib basis. In case rates are Ex-Works basis, loading of expenses i.e., freight, transit insurance shall be done by BHEL at its discretion to arrive at Landed prices. Comparison shall be done at Landed cost to BHEL.

Tenders should be free from CORRECTION AND ERASURES. Corrections if any must be attached. Sealed Tenders can be dropped in the tender box labeled as 'Tender box for MM contracts'. This tender box is located at the entrance of Admin block BHEL Goindwal.

Sealed quotations shall reach by 1500 Hrs on due date.

Time of submission is by 1500 Hrs on Due Date. Time of Techno-Commercial bid (Part I) opening is 1600 Hrs on due date. Based on evaluation of techno-commercial offers, Price bids of bidders who qualify from techno-commercial evaluation shall be opened. BHEL may decide to open the Price bid same day at 1700 hrs. If not opened on the same day, all qualifying bidders shall be notified for date of opening of Price bids.

IF THE OFFER IS NOT ACCOMPANIED WITH ACCEPTANCE OF TERMS AND CONDITIONS, IT SHALL BE CONCLUDED THAT ALL THE TERMS AND CONDITIONS ARE ACCEPTABLE AND NO CLAIM WHATSOEVER SHALL BE ENTERTAINED LATERON.

2. VALIDITY OF OFFERS:

The offers shall be kept open for acceptance for **60** days from the date of opening of the tender. In case of extension of tender opening date, the validity shall be suitably revised.



BHEL GOINDWAL

TERMS AND CONDITIONS FOR
(Tender Enquiry No.1213-096 Dated 03.10.2012)

3. SCOPE OF SUPPLY

Material shall be supplied as per the applicable latest Technical Document No. Material Standard requirements/ Drawing Nos. National & International material Standards shall have to be arranged by vendors themselves. **+/- 5% quantity variation is acceptable.**

4. REPLACEMENT OF REJECTION:

If the material is rejected due to defective workmanship during inspection or at the time of actual use, within the guarantee period (i.e. as per clause 11), the rejected material shall be replaced by the supplier. Corresponding quantity shall be treated as unsupplied against respective purchase order till replacement is received at BHEL. If the material is found defective and rejected during use for which payment has already been released the rejected quantity shall be supplied free of cost by the vendor within a month of intimation of the rejection by BHEL.

5. DELIVERY SCHEDULE:

Supplies shall be affected and completed as per schedule mentioned in the POs. We require **minimum 25% of total qty in first two months and balance qty within next two months from date of PO.** Further, BHEL may release delivery schedule from time to time based upon our requirement. Vendor shall be required to complete the order as per the BHEL schedule requested.

6. ACCESS TO MANUFACTURING PREMISES:

While Purchase Orders placed on the vendor are under execution, authorized representatives of BHEL shall be allowed free access to the manufacturing facilities for the purpose of inspection or monitoring the progress of purchase orders. This access will also be extended to representatives of BHEL's customers accompanying the authorized representative/s of BHEL (which shall be intimated in advance), if our contractual requirements with our customers call for the same.

7. TERMS OF PAYMENT:

- a. Due payment against supplies received shall be due after 30 days of receipt and acceptance of material and shall be paid within next 15 days period. In case of any deviation from standard payment term mentioned BHEL at it's discretion may load on the item price at prime lending rate of SBI + 2% for the period of relaxation sought by bidder.
- b. Documents to be submitted
 - i. Commercial invoice (in duplicate)
 - ii. Excise invoice (in duplicate) valid for claiming CENVAT credit
 - iii. Original VAT invoice valid for claiming input tax credit, if applicable
 - iv. Material Test Certificates (MTC) and
 - v. Compliance Certificate.
- c. Above documents should include your Registration numbers such as ECC no, PAN no, CST no, TIN/ VAT nos. etc.



TERMS AND CONDITIONS FOR
(Tender Enquiry No.1213-096 Dated 03.10.2012)

- d. It is mandatory to mention proper material codes in the invoices and separate invoices to be raised for different POs.
- e. **BHEL releases payment through EFT mode ONLY. Necessary details may please be submitted by filling required format before release of payment.**

5. INSPECTION:

1. All required tests shall be carried out by vendor at no extra cost. Relevant TCs shall accompany the consignment. **BHEL may decide to inspect itself/arrange third party at vendors' works itself as and when necessary with prior intimation to the vendor.** No additional charges shall be claimed for such inspections.
2. **Vendor will give inspection call sufficiently in advance considering the delivery period stipulated in the purchase order.**
3. Material Test Certificates (MTC), Inspection reports and Compliance/Guarantee Certificate are to be provided along with the supplies.
4. Latest applicable revisions of standards/procedures to be referred.
5. Any inspection carried out before supply by vendor/incoming stage at BHEL notwithstanding, if any defect/non-conformity is noted during processing, the same shall be attended/replaced by vendor at no extra cost.

6. PREFERENCES FOR MSE's:

Preferences as mentioned in "Public Procurement Policy for Micro and Small Enterprises (MSEs) Order, 2012" shall be given to Micro and Small enterprises.

Main points which are mentioned in the above order are as follows:

- 20% Procurement of the tender value shall be made from MSE (Micro, Small Enterprises) firms.
- 4% from the above mentioned 20% procurement quantity shall be procured from MSE's owned by SC /ST's. Failure to participate by any MSE owned by SC/ST's this 4% quantity shall be procured from other MSEs.
- EMD shall be exempted for MSE's. All these benefits are subject to production of all statutory documents
- In tender, participating Micro and Small Enterprises quoting price within price band of L1+15 per cent shall also be allowed to supply a portion of requirement by bringing down their price to L1 price in a situation where L1 price is from someone other than a Micro and Small Enterprise and such Micro and Small Enterprise shall be allowed to supply up to 20 per cent of total tendered value. In case of more than one such Micro and Small Enterprise, the supply shall be shared proportionately (to tendered quantity).

All these preferences are applicable subject to the submission of applicable certificates (i.e. District Industries Centers or Khadi and Village Industries Commission or Khadi and Village Industries Board or Coir Board or National Small Industries Corporation or Directorate of Handicrafts and Handloom or any other body specified by Ministry of Micro, Small and Medium Enterprises)

Mamta kumar

7. LOADING CRITERIA

BHEL reserves the right to negotiate with L1 or re-float the tender in case the quoted prices are not acceptable. BHEL will give tender quantity according to following directions:

1. Tender quantity shall be divided in the proportion 50:30:20 (50% for L1, 30 % for L2 bidder subject to acceptance of L1 rate and 20% for MSE's) in case the L1 vendor is not a MSE subject to following conditions:
 - I. In tender, participating Micro and Small Enterprises quoting price within price band of L1+15 per cent shall also be allowed to supply a portion of requirement at L1 price in a situation where L1 price is from someone other than a Micro and Small Enterprise and such Micro and Small Enterprise shall be allowed to supply up to 20 per cent of total tendered value. In case of more than one such Micro and Small Enterprise, the supply shall be shared equally.
 - II. 20% from the 20% quantity (i.e. 4% of the tender quantity) offered to the MSE's shall be reserved for MSE's owned by SC/STs. In event of failure of such Micro and Small Enterprises to participate in tender process or meet tender requirements and L1 price, 4 per cent quantity for Micro and Small Enterprises owned by SC/ST entrepreneurs shall be met from other Micro and Small Enterprises.
 - III. In case any MSE vendor does not accept the L1 price, the above mentioned 20% quantity shall be offered to L1 vendor.
2. In case if the L1 vendor is MSE then quantity shall be provided as 66 % to L1 vendor, 30 % to L2 bidder and 4% tender quantity shall be offered to the MSEs owned by SC/ST's in the price band of L1+15%. In event of failure of such Micro and Small Enterprises to participate in tender process or meet tender requirements and L1 price, 4 per cent sub-target for procurement earmarked for Micro and Small Enterprises owned by SC/ST entrepreneurs shall be met from L1 vendor.
3. In case if L1 vendor is MSE owned by SC/ST's then the order quantity will be in the ratio of 70:30 (70% for L1 and 30 % for L2 subject to acceptance of L1 rate for L2 bidder). If L2 does not accept L1 rate then this quantity will be offered to L1 bidder.
4. In case no MSEs participating in the tender then the whole quantity will be in the ratio of 70:30 (70% for L1 and 30 % for L2 subject to acceptance of L1 rate for L2 bidder). If L2 does not accept L1 rate then this quantity will be offered to L1 bidder.

In case of non- acceptance of counter offer by any vendor after above applicable provisions the whole quantity would be offered to L1 vendor.

This ratio can be altered in case of any failure on part of any bidder regarding delivery commitment/quantity/quality of material.

All above mentioned preferences shall be given to MSEs and SC/STs only on the submission of documentary evidence.

8. GUARANTEE:

Monmeet Kumar



BHEL GOINDWAL

TERMS AND CONDITIONS FOR
(Tender Enquiry No.1213-096 Dated 03.10.2012)

Vendor shall give a guarantee of 18 months from the date of dispatch or 12 months from use, against manufacturing defects, whichever is earlier.

9. PENALTY FOR LATE DELIVERY:

'Time is the essence of the contract'. As such, delivery of goods specified in the Purchase Orders released under the scope of this contract shall be made within the time limit prescribed therein. Penalty for late delivery will be applicable @ 1.0% per week or part thereof subject to a maximum of 10.0 %.

BHEL reserves the right to receive or not receive the material after the due date of PO.

10. RISK PURCHASE:

BHEL shall be entitled to terminate the contract/pending POs at any stage and to purchase elsewhere at the risk and cost of the vendor, either the whole of the goods or any part thereof which the supplier has failed to deliver or dispatch within the time stipulated as aforesaid. Vendor shall be liable for the losses, which BHEL may sustain by way of such risk purchase in addition to aforesaid penalty for delayed delivery.

11. SUB-CONTRACT:

The purchase order or any part thereof shall not be sub-contracted, assigned or otherwise transferred without previously obtaining the BHEL's consent in writing.

12. FORCE MAJEURE:

If at any time during the continuance of the contract, the performance in which or in any part by either party of any obligations under the contract are prevented or delayed by reason of any war, hostilities, acts of public enemy, civil commotion, sabotage, fires, explosions, epidemics, quarantine restrictions, or acts of God (hereinafter referred to "an events" then provided the notice of happening of any such event is given by either party to the other within 21 days of the occurrence thereof, neither party shall by reason of such event be entitled to terminate the contract nor shall either party have any claim for damages against the other in respect of such non-performance and delay in performance and delivery under the contract shall be resumed as soon as practicable after such event has come to an end or ceased to exist. If the performance in whole or part of any obligation under the contract is prevented or delayed by reason of any such event, claims of extension of time shall be granted for periods considered reasonable by BHEL subject to prior notification by the vendor to BHEL of the particulars of the event and supply to BHEL, if required, of any supporting evidence. Any waiver of time in respect of partial installment shall not be deemed a waiver of time in respect of remaining deliveries.

13. DISPUTES:

In the event of any dispute and/or difference arising between the Vendor and BHEL as to interpretation and/or execution of the contract and/or the respective rights and liabilities of the parties, such disputes and/or differences shall be referred to the sole arbitrator nominated by BHEL. The provisions of the Indian Arbitration Act and the rules there under shall apply to



TERMS AND CONDITIONS FOR
(Tender Enquiry No.1213-096 Dated 03.10.2012)

such arbitration. The award passed by the arbitrator shall be final and conclusively binding on all the parties.

14. JURISDICTION:

The court of the place from where the purchase order is issued during the contractual period shall alone have jurisdiction to decide any dispute arising out of or in connection with the purchase order.

15. MSME Certification:

If the bidder is registered as any of Micro/Small/Medium enterprise as defined in Micro Small and Medium Enterprises Development Act, 2006; a copy of registration certificate to be attached.

16. CLARIFICATIONS

The correspondence exchanged against the tender from both tenderer and BHEL through email are considered as valid document legally though it is not signed. It is treated as valid confirmations made on behalf of the respective company and very much comes under the legal ambit of the business transaction and hence it is binding on both the parties to the business. Any transaction pertaining to the tender from both the parties of business done round the clock irrespective of the office or business hours of the companies, are valid legally and binding on both the parties. This applies to the extent only in such cases where deadline time for transaction is not specifically declared by either or both the parties to the business.

17. LOI(Letter of Intent)

BHEL may issue LOI prior to the PO for any reason whatsoever. The LOI in such cases is to be treated as PO for all practical purposes and all the Terms & Conditions of the tender shall be applicable from the date of issue of LOI.

18. GENERAL:

- a) BHEL will not be bound by any power of attorney granted by the vendors or by changes in the composition of the firm made subsequent to the execution of the contract. They may, however, recognize such power of attorney and changes after obtaining proper legal advice, the cost of which will be chargeable to the vendor concerned.
- b) BHEL reserves the right to extend the due date of opening, which shall be informed. Validity of offer shall be deemed to be revised accordingly.
- c) BHEL reserves the right to accept or reject any part or whole of the tender of a bidder by assigning a valid reason thereof. BHEL reserves the right to cancel the tender without assigning any reason thereof and without any obligation before any commitment.
- d) If possible, please submit soft copy of price quotation [copied on a blank CD of standard make] put in the sealed offer.



BHEL GOINDWAL

TERMS AND CONDITIONS FOR
(Tender Enquiry No.1213-096 Dated 03.10.2012)

- e) Acceptance of all terms and conditions, in the form of signed copy of T&C or confirmation separately written, shall be submitted along with quotation. If nothing is mentioned, it shall be concluded that terms and conditions are acceptable.
- f) BHEL reserves the right to delete any item from the tender at any stage of tender process without assigning any reason.

19. BANNED FIRMS:

The offers of the bidders who are on the banned list as also the offer of the bidders, who engage the services of the banned firms, shall be rejected. The list of banned firms is available on BHEL website www.bhel.com.

20. Supplier Registration:

Bidders, who are not currently on registered list of BHEL IVP Goindwal Sahib, may submit duly filled format for "Vendor Registration form". The form can be downloaded from our website www.bhel.com or can be requested at vishal@bhelivp.in or manmeet@bhelivp.in. Registered vendors with BHEL IVP GWL have to mention their vendor code. Registered vendors with any other unit of BHEL are also required to mention the vendor code given by respective BHEL unit along with photocopy of latest POs from BHEL unit. Techno-commercially qualified bidders may be asked for submission of supplier registration form for getting registered with BHEL, IVP, Goindwal.

**CHECKLIST AND SEQUENCE OF DOCUMENTS TO BE SUBMITTED IN TWO PARTS
BIDS**

S. No.	Document	Status
1.	Techno-commercial bid sealed in separate envelope superscribing tender enquiry detail, due date of opening, sender address	Sealed envelope marked as Part-I "Techno-commercial Bid" Yes, sealed
2.	Price Bid sealed in separate envelope superscribing tender enquiry detail, due date of opening, sender address	Sealed envelope marked as Part-II "Price Bid" Yes, sealed
3.	All two sealed envelopes put in an outer envelope mentioning all details like Enquiry no., description, due date	Yes

Manmeet kumar

DRAWING NO. 3-20-201-00166

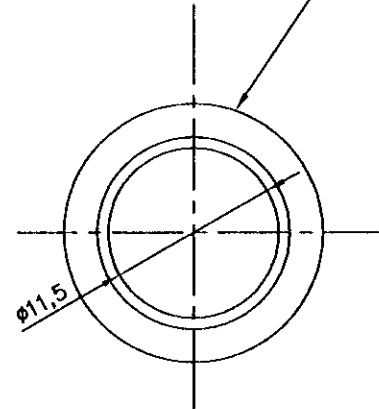
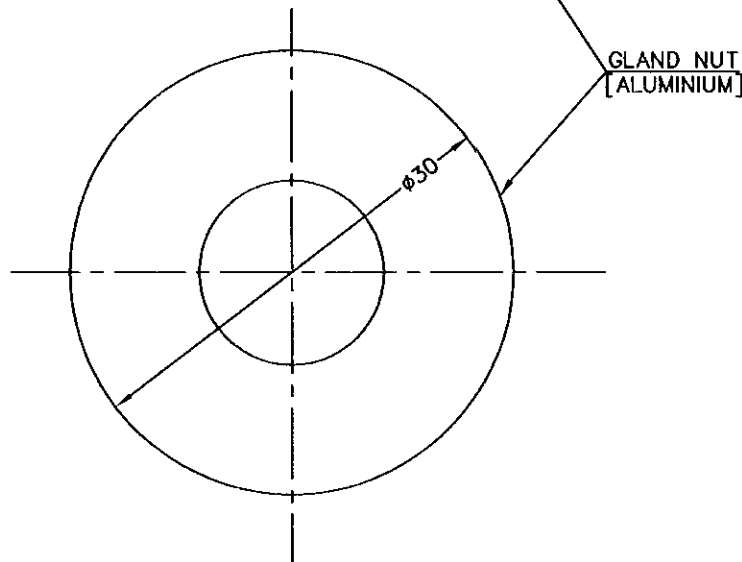
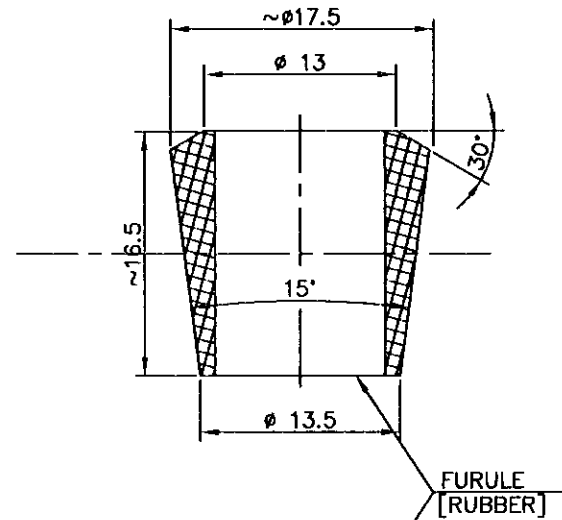
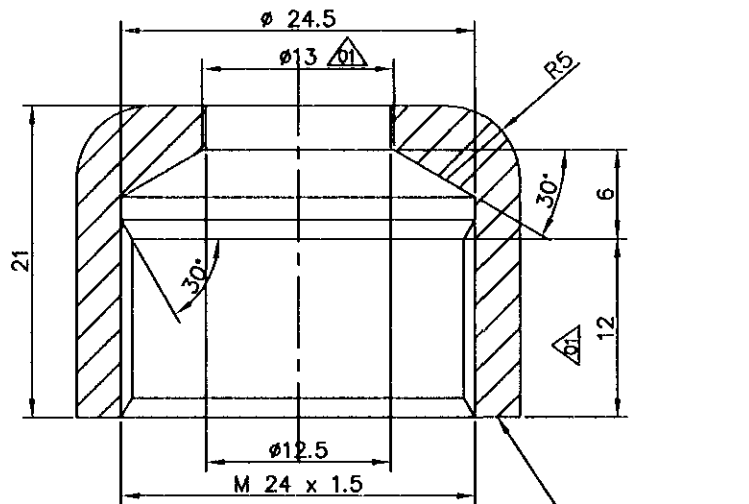
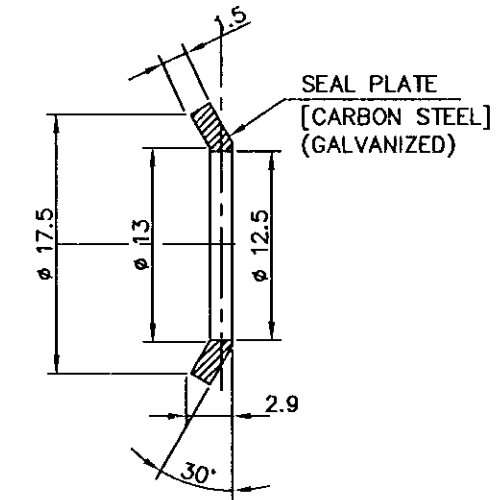
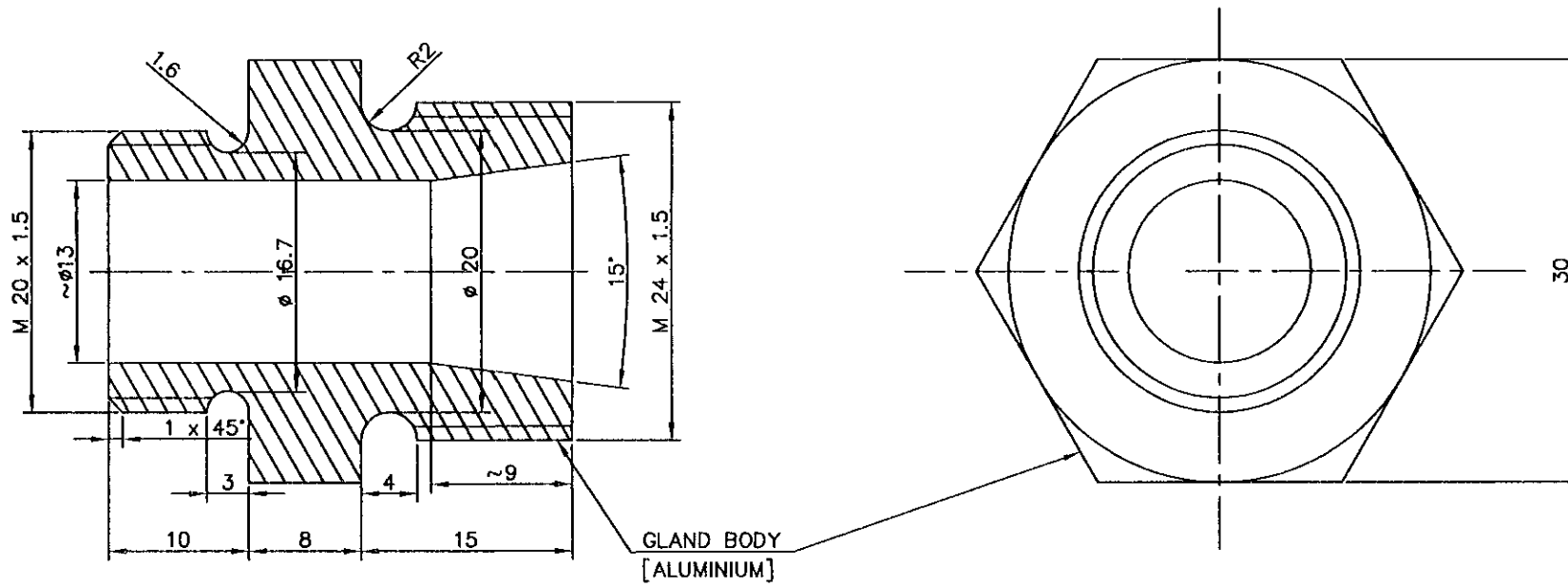

NOTES:-

- FOR QUALITY REQUIREMENTS REFER LATEST APPLICABLE QUALITY PROCEDURES.
- CABLE GLAND BE SUPPLIED IN ASSEMBLED CONDITION.

PART CODE : 963531540000

NO OFF	DESCRIPTION	MATL CODE	MATL SPECN	HEAT TREATMENT	SCRAP SORT	NET WT (kg)	GROSS WT (kg)	DRAWING No	ITEM No
--------	-------------	-----------	------------	----------------	------------	-------------	---------------	------------	---------

TYPE OF PRODUCT OR NAME OF CUSTOMER/PROJECT

BHARAT HEAVY ELECTRICALS LTD., UNIT: HIGH PRESSURE BOILER PLANT. TIRUCHIRAPALLI-620014.	DRN	NAME	SIGN	DATE	NO. OF VAR.
	CHD	V.ARUMUGAM			
	APPD	K.SRIDHARAN			

DEPT	SCALE	WEIGHT (KG).	REFERENCE INFORMATION	NO. OF ITEMS
SB	NTS	0.02		
CODE 330				

TITLE	CARD CODE	DRAWING NO.	REV
CABLE GLAND	U 01	3-20-201-00166	03

REV	DATE	ALTERED
03	11.06.01	CHD & APPD

DRG.UPDATED AND REDRAWN.
DCN: SB: 1298

CAUTION: The information on this document is the property of BHARAT HEAVY ELECTRICALS LTD. It must not be used directly or indirectly in any way detrimental to the interest of the company.

Techno-Commercial Bid Annexure to Enquiry No.1213-096 Dated 03.10.2012, Due date 24.10.2012

Enq SI. No.	Code	Description of material	Drg No	Enquiry Qty (Nos.)	Quoted	Unit Basic Price, Rs. per pc.
1	963531540000	CABLE GLAND - M20X1.5 - 30016600	32020100166/03	5100	Yes/No	"Pl. see price bid"

Excise Duty rate (mention in % if applicable, mention as **NIL** if not applicable)

Pl. clearly mention in % if applicable

Cess on ED rate (mention in % if applicable)

CST (%) / VAT (%)

Validity of offers (**As per BHEL terms 60 days validity is required**)

Pl. clearly mention

The above prices are **Firm, without any price escalation; are Rs. per piece; and are on FOR Goindwal Sahib basis.**

We accept all terms and conditions of the Tender Enquiry No. 1213-096 dated 03.10.2012

MSE Status

Yes/No	Yes/NO
Micro/Small	Other

If Micro or small then owner of company belong to

Yes/No	Yes/NO
SC/ST	Other

If Yes in Micro/Small/SC/ST, then send relevant document.

Authorised signatory with seal

Price Bid Annexure to Enquiry No.1213-096 Dated 03.10.2012, Due date 24.10.2012

Enq Sl. No.	Code	Description of material	Drawing No.	Enquiry Qty (Nos.)	Unit Basic Price, Rs. per No.
1	963531540000	CABLE GLAND - M20X1.5 - 30016600	32020100166/03	5100	To be filled by bidder

Authorised signatory with seal