



# Bharat Heavy Electricals Limited

Industrial Valves Plant

Goindwal, Punjab-143422

## Notice Inviting Tender

- Inquiry No 1112-225
- Completed Forms to be submitted by 26.03.2012 15:00:00
- Due Date of Opening 26.03.2012 15:30:00
- Address  
Manmeet Kumar  
Material Management  
BHEL, Industrial Valves Plant  
433, Industrial Complex  
Goindwal Sahib  
Distt Tarn Taran  
Punjab 143422
- Item Description **As per annexure of Techno-commercial and price bid.**



BHEL GOINDWAL

TERMS AND CONDITIONS FOR  
(Tender Enquiry No.1112-225 Dated 16.03.2012)

**DUE DATE OF OPENING: 26.03.2012**

**1. INVITING TENDERS**

Bidders should primarily be engaged in manufacturing/supplying of Push Buttons. **Stockists, dealers will have to submit authorization certificate from their manufacturers'.**

Tenders in two part bids are invited.

Sealed tenders in two parts; Part-I: Techno-commercial bid and Part-II: Price bid are hereby invited for supply of **Push Buttons** as per BHEL Drawings, technical document **TSBs** The relevant documents are attached with the Enquiry.

The two bids should be submitted in **separate sealed inner envelopes** duly mentioning the detail as follows:

Bid	Bid description	Superscribing on envelope	*** Should contain ***
Part I in First sealed envelope	Techno-Commercial Offer	Part-I (Techno-Commercial) bid against tender enquiry no: 1112-225 dated 16.03.2012 due for opening on 26.03.2012	<ol style="list-style-type: none"> <li>Acceptance of all terms and conditions of tender enquiry. (Preferred is submitting signed copy of terms and conditions; if nothing is mentioned for any term, it shall be summarily concluded that the same is acceptable and no representation whatsoever shall be entertained later on).</li> <li><b>Un-priced</b> bid as per format attached. <b>All details, i.e. whether quoted for item, duties and taxes etc. should be filled.</b></li> </ol>
Part II in Second sealed envelope	Price Bid	Part-II (Price) bid against tender enquiry No: 1112-225  Dated: 26.03.2012	<p><b>Price bid in the format attached.</b> Preferably the price bid envelop should contain ONLY the price bid. Further, if even the same conditions are mentioned in the Part-II, but after scrutiny of Part-I, the bidder has agreed to BHEL terms, the same shall be binding and any such condition found in Part-II shall in no case be discussed.</p> <p>Anything other than price mentioned in the price bid shall be considered invalid</p>

Both the sealed envelopes should be put in outer sealed envelope superscribing all details i.e. Enquiry Number, Date, Supplier's Name and Address and Item.

**Time of submission by 1500 Hrs on Due Date. Time of Techno-Commercial bid (Part I) opening is 1530 Hrs on due date. Based on evaluation of techno-commercial offers, Price bids of bidders who qualify from techno-commercial evaluation shall be opened. BHEL may decide to open the Price bid same day at 1700 hrs. If not opened on the same day, all qualifying bidders shall be notified for date of opening of Price bids.**

Sealed Tenders can be dropped in the tender box labeled as 'Tender box for MM contracts'. This tender box is located at the entrance of Admin block BHEL Goindwal.



BHEL GOINDWAL

TERMS AND CONDITIONS FOR  
(Tender Enquiry No.1112-225 Dated 16.03.2012)

**2. VALIDITY OF OFFERS:**

The offers shall be kept open for acceptance for **60** days from the date of opening of the tender. In case of extension of tender opening date, the validity shall be suitably revised.

**3. SCOPE OF SUPPLY**

Material shall be supplied as per the applicable latest Technical Document **TSBs** Material Standard requirements/ Drawing No. National & International material Standards shall have to be arranged by vendors themselves. +/- 5% quantity variation is acceptable.

**4. REPLACEMENT OF REJECTION:**

If the material is rejected due to defective workmanship during inspection or at the time of actual use, within the guarantee period (i.e. as per clause 11), the rejected material shall be replaced by the supplier. Corresponding quantity shall be treated as unsupplied against respective purchase order till replacement is received at BHEL. If the material is found defective and rejected during use for which payment has already been released the rejected quantity shall be supplied free of cost by the vendor within a month of intimation of the rejection by BHEL.

**5. DELIVERY SCHEDULE:**

Supplies shall be affected and completed as per schedule mentioned in the POs. We require **500 Nos in first month and balance within next months. Further, BHEL may release delivery schedule from time to time based upon our requirement.** Vendor shall be required to complete the order as per the BHEL schedule requested.

**6. ACCESS TO MANUFACTURING PREMISES:**

While Purchase Orders placed on the vendor are under execution, authorized representatives of BHEL shall be allowed free access to the manufacturing facilities for the purpose of inspection or monitoring the progress of purchase orders. This access will also be extended to representatives of BHEL's customers accompanying the authorized representative/s of BHEL (which shall be intimated in advance), if our contractual requirements with our customers call for the same.

**7. TERMS OF PAYMENT:**

- a. Due payment against supplies received shall be due after 30 days of receipt and acceptance of material and shall be paid within next 15 days period.
- b. Documents to be submitted
  - i. Commercial invoice (in duplicate)
  - ii. Excise invoice (in duplicate) valid for claiming CENVAT credit
  - iii. Original VAT invoice valid for claiming input tax credit, if applicable
  - iv. Material Test Certificates (MTC) and
  - v. Compliance Certificate.

*Manmeet Kumar*



BHEL GOINDWAL

TERMS AND CONDITIONS FOR  
(Tender Enquiry No.1112-225 Dated 16.03.2012)

- c. Above documents should include your Registration numbers such as ECC no, PAN no, CST no, TIN/ VAT nos. etc.
- d. **It is mandatory to mention proper material codes in the invoices and separate invoices to be raised for different POs.**
- e. **BHEL releases payment through EFT mode ONLY. Necessary details may please be submitted by filling required format before release of payment.**

**8. INSPECTION:**

1. All required tests shall be carried out by vendor at no extra cost. Relevant TCs shall accompany the consignment. **BHEL may decide to inspect itself/arrange third party at vendors' works itself as and when necessary with prior intimation to the vendor.** No additional charges shall be claimed for such inspections.
2. **Vendor will give inspection call sufficiently in advance considering the delivery period stipulated in the purchase order.**
3. Material Test Certificates (MTC), Inspection reports and Compliance/Guarantee Certificate are to be provided along with the supplies.
4. Latest applicable revisions of standards/procedures to be referred.
5. Any inspection carried out before supply by vendor/incoming stage at BHEL not withstanding, if any defect/non-conformity is noted during processing, the same shall be attended/replaced by vendor at no extra cost.

**9. COUNTER OFFERS**

BHEL reserves the right to negotiate with L1 or re-float the tender in case the quoted prices are not acceptable. BHEL reserves the right to give counter-offer to L2 vendors in order to have broader vendors base for ensuring timely delivery.

**10. LOADING CRITERIA**

The qualifying quantities shall be divided between L1 and L2 in the ratio of 60:40 subject to:

L2 acceptance of L1 rates.

Counter offer is limited to L2 bidder only. Above ratio can be altered in case of any failure on part of L1 regarding delivery commitment/quality of material. This ratio can also be altered circumstantially.

**11. GUARANTEE:**

Vendor shall give a guarantee of 18 months from the date of dispatch or 12 months from use, against manufacturing defects, whichever is earlier.

**12. PENALTY FOR LATE DELIVERY:**

'Time is the essence of the contract'. As such, delivery of goods specified in the Purchase Orders released under the scope of this contract shall be made within the time limit prescribed therein. Penalty for late delivery will be applicable @ 0.5% per week or part thereof subject to a maximum of 5.0 %.

BHEL reserves the right to receive or not receive the material after the due date of PO.



BHEL GOINDWAL

TERMS AND CONDITIONS FOR  
(Tender Enquiry No.1112-225 Dated 16.03.2012)

**13. RISK PURCHASE:**

BHEL shall be entitled to terminate the contract/pending POs at any stage and to purchase elsewhere at the risk and cost of the vendor, either the whole of the goods or any part thereof which the supplier has failed to deliver or dispatch within the time stipulated as aforesaid. Vendor shall be liable for the losses, which BHEL may sustain by way of such risk purchase in addition to aforesaid penalty for delayed delivery.

**14. SUB-CONTRACT:**

The purchase order or any part thereof shall not be sub-contracted, assigned or otherwise transferred without previously obtaining the BHEL's consent in writing.

**15. FORCE MAJEURE:**

If at any time during the continuance of the contract, the performance in which or in any part by either party of any obligations under the contract are prevented or delayed by reason of any war, hostilities, acts of public enemy, civil commotion, sabotage, fires, explosions, epidemics, quarantine restrictions, or acts of God (hereinafter referred to "an events" then provided the notice of happening of any such event is given by either party to the other within 21 days of the occurrence thereof, neither party shall by reason of such event be entitled to terminate the contract nor shall either party have any claim for damages against the other in respect of such non-performance and delay in performance and delivery under the contract shall be resumed as soon as practicable after such event has come to an end or ceased to exist. If the performance in whole or part of any obligation under the contract is prevented or delayed by reason of any such event, claims of extension of time shall be granted for periods considered reasonable by BHEL subject to prior notification by the vendor to BHEL of the particulars of the event and supply to BHEL, if required, of any supporting evidence. Any waiver of time in respect of partial installment shall not be deemed a waiver of time in respect of remaining deliveries.

**16. DISPUTES:**

In the event of any dispute and/or difference arising between the Vendor and BHEL as to interpretation and/or execution of the contract and/or the respective rights and liabilities of the parties, such disputes and/or differences shall be referred to the sole arbitrator nominated by BHEL. The provisions of the Indian Arbitration Act and the rules there under shall apply to such arbitration. The award passed by the arbitrator shall be final and conclusively binding on all the parties.

**17. JURISDICTION:**

The court of the place from where the purchase order is issued during the contractual period shall alone have jurisdiction to decide any dispute arising out of or in connection with the purchase order.

**18. MSME Certification:**

*Manmeet Kaur*



BHEL GOINDWAL

TERMS AND CONDITIONS FOR  
(Tender Enquiry No.1112-225 Dated 16.03.2012)

If the bidder is registered as any of Micro/Small/Medium enterprise as defined in Micro Small and Medium Enterprises Development Act, 2006; a copy of registration certificate to be attached.

**19 CLARIFICATIONS**

The correspondence exchanged against the tender from both tenderer and BHEL through email are considered as valid document legally though it is not signed. It is treated as valid confirmations made on behalf of the respective company and very much comes under the legal ambit of the business transaction and hence it is binding on both the parties to the business. Any transaction pertaining to the tender from both the parties of business done round the clock irrespective of the office or business hours of the companies, are valid legally and binding on both the parties. This applies to the extent only in such cases where deadline time for transaction is not specifically declared by either or both the parties to the business.

**20 LOI(Letter of Intent)**

BHEL may issue LOI prior to the PO for any reason whatsoever. The LOI in such cases is to be treated as PO for all practical purposes and all the Terms & Conditions of the tender shall be applicable from the date of issue of LOI.

**21 GENERAL:**

- a) BHEL will not be bound by any power of attorney granted by the vendors or by changes in the composition of the firm made subsequent to the execution of the contract. They may, however, recognize such power of attorney and changes after obtaining proper legal advice, the cost of which will be chargeable to the vendor concerned.
- b) BHEL reserves the right to extend the due date of opening, which shall be informed. Validity of offer shall be deemed to be revised accordingly.
- c) BHEL reserves the right to accept or reject any part or whole of the tender of a bidder by assigning a valid reason thereof. BHEL reserves the right to cancel the tender without assigning any reason thereof and without any obligation before any commitment.
- d) If possible, please submit soft copy of price quotation [copied on a blank CD of standard make] put in the sealed offer.
- e) Acceptance of all terms and conditions, in the form of signed copy of T&C or confirmation separately written, shall be submitted along with quotation. If nothing is mentioned, it shall be concluded that terms and conditions are acceptable.

**22. BANNED FIRMS:**

The offers of the bidders who are on the banned list as also the offer of the bidders, who engage the services of the banned firms, shall be rejected. The list of banned firms is available on BHEL website [www.bhel.com](http://www.bhel.com).



BHEL GOINDWAL

TERMS AND CONDITIONS FOR  
(Tender Enquiry No.1112-225 Dated 16.03.2012)

**23. Supplier Registration:**

**Bidders, who are not currently on registered list of BHEL IVP Goindwal Sahib, may submit duly filled format for "Vendor Registration form".** The form can be downloaded from our website [www.bhel.com](http://www.bhel.com) or can be requested at [vishal@bhelivp.in](mailto:vishal@bhelivp.in) or [manmeet@bhelivp.in](mailto:manmeet@bhelivp.in). Registered vendors with BHEL IVP GWL have to mention their vendor code. Registered vendors with any other unit of BHEL are also required to mention the vendor code given by respective BHEL unit along with photocopy of latest POs from BHEL unit. Techno-commercially qualified bidders may be asked for submission of supplier registration form for getting registered with BHEL, IVP, Goindwal.

**24. REVERSE AUCTION**

BHEL reserves the option to either finalise the tender by opening sealed price bids (Part-II) submitted with the offer on a specified date and time in the presence of bidders, who may like to be; or carrying out live reverse auction on-line. In case of reverse auction, adequate infrastructure like internet connection, uninterrupted power supply, printer, fax machine etc. will have to be arranged by bidder. BHEL will engage a service provider who shall interact, educate, guide and coordinate with bidder for reserve auction. Date and time of reverse auction shall be informed.

Information and general terms and conditions governing RA(Reverse Auction) are given below.

**GENERAL TERMS AND CONDITIONS OF RA**

Against this enquiry for the subject item with detailed scope of supply as per enquiry specifications, BHEL may resort to "REVERSE AUCTION PROCEDURE" i.e., ON LINE BIDDING ON INTERNET.

1. For the proposed reverse auction, technically and commercially acceptable bidders only shall be eligible to participate.
2. BHEL will engage the services of a service provider who will provide all necessary training and assistance before commencement of on line bidding on internet.
3. BHEL will inform the vendor in writing in case of reverse auction, the details of Service Provider to enable them to contact & get trained.
4. Business rules like event date, time, Start price, bid decrement, extensions etc. also will be communicated through service provider for compliance.
5. Vendors have to fax the Compliance form in the prescribed format (provided by Service provider) before start of Reverse auction. Without this, the vendor will not be eligible to Participate in the event.
6. BHEL will provide the calculation sheet (e.g., EXCEL sheet) which will help to arrive at "Total Cost to BHEL" like Packing & forwarding charges, Taxes and Duties, Freight charges, Insurance, Service Tax for Services and loading factors (for non-compliance to BHEL standard Commercial terms & conditions) for each of the vendor to enable them to fill-in the price and keep it ready for keying in during the Auction.



BHEL GOINDWAL

TERMS AND CONDITIONS FOR  
(Tender Enquiry No.1112-225 Dated 16.03.2012)

7. Reverse auction will be conducted on scheduled date & time.
8. At the end of Reverse Auction event, the lowest bidder value will be known on the network.
9. The lowest bidder has to Fax the duly signed Filled-in prescribed format as provided on case-to-case basis to BHEL through Service provider within 24 hours of Auction without fail.
10. Any variation between the on-line bid value and the signed document will be considered as sabotaging the tender process and will invite disqualification of vendor to conduct business with BHEL as per prevailing procedure.
11. In case BHEL decides not to go for Reverse Auction procedure for this tender enquiry, the Price bids and price impacts, if any, already submitted and available with BHEL shall be opened as per BHEL's standard practice.

**CHECKLIST AND SEQUENCE OF DOCUMENTS TO BE SUBMITTED IN TWO PARTS BIDS**

S. No.	Document	Status
1	Envelope should contain  (1) Techno-Commercial bid preferably with signed copy of terms & conditions (2) Unpriced bid format (Annexure-I) with applicable taxes (item prices not to be mentioned)	Yes, Sealed  Sealed envelope marked as Part-I "Techno-Commercial Bids"
2.	Price Bid (Preferably in Annexure-II) sealed in separate envelope superscribing tender enquiry detail, due date of opening, sender address	Yes, sealed  Sealed envelope marked as Part-II "Price Bid"
3.	All two sealed envelopes put in an outer envelope mentioning all details like Enquiry no., description, due date	Yes

*Manmeet Kumar*

Price Bid Annexure to Enquiry No.1112- 225 Dated 16.03.2012 due date 26.03.2012

Enq Sl. No.	Code	Description of material	TDC No.	Fit for Hole	Enquiry Qty (Nos.)	Unit Basic Price, Rs. per Pc
1	963533470000	PUSH BUTTON GREEN	TSB068/05	As Per reference Drg	1500	To be filled by Bidder
2	963533480000	PUSH BUTTON RED	TSB068/05		1500	To be filled by Bidder

Authorised signatory with seal

Techno-Commercial Bid Annexure to Enquiry No.1112-225 Dated 16.03.2012, Due date 26.03.2012

Enq Sl. No.	Code	Description of material	TDC No.	Fit of hole	Enquiry Qty (Nos.)	Quoted	Unit Basic Price, Rs. per pc.
1	963533470000	PUSH BUTTON GREEN	TSB068/05	As per reference Drg	1500	Yes/No	"Pl. see price bid"
2	963533480000	PUSH BUTTON RED	TSB068/05		1500	Yes/No	"Pl. see price bid"
Excise Duty rate (mention in % if applicable, mention as <b>NIL</b> if not applicable)							
Cess on ED rate (mention in % if applicable)							
CST (%) / VAT (%)							
Validity of offers ( <b>As per BHEL terms 60 days validity is required</b> )							
The above prices are <b>Firm, without any price escalation; are Rs. per piece; and are on FOR Goindwal Sahib basis.</b>							
We accept all terms and conditions of the Tender Enquiry No. 1112-225 dated 16.03.2012							
Authorized signatory with seal							

We accept all terms and conditions of the Tender Enquiry No. 1112-225 dated 16.03.2012

Authorized signatory with seal

Reference Drawing

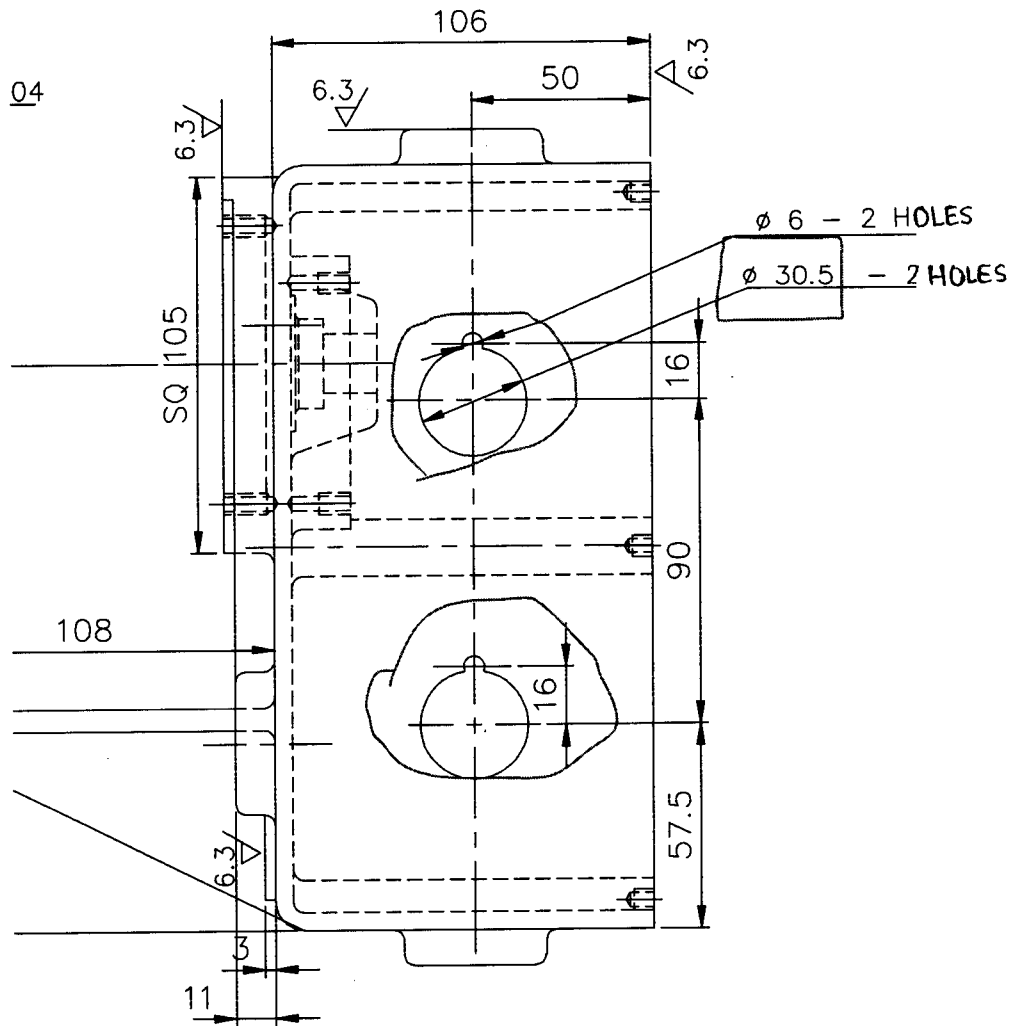



**PRODUCT ENGINEERING / V & SB  
TECHNICAL DELIVERY CONDITIONS FOR  
SUBDELIVERY COMPONENTS OF SOOT BLOWERS**

TSB : 068 | Rev. 05

SHEET No. 01 of 01

**PUSH BUTTON**

- 1.0 Component : Push button : Green  
Push button : Red
- 1.1 Material Code : 96 353 347 0000 Push button-Green  
96 353 347 0300 Push Button / Green / Start / 2NO+2NC  
96 353 348 0000 Push button-Red  
96 353 348 0400 Push Button-Red Lockable Stay Put Type  
96 353 348 0500 Push Button -Red /Latched / Mushroom type  
2NO+2NC
- 1.2 Application : Push button green is used to start the wall de-slagger and push  
button red is used to retract the wall de-slagger
- 1.3 Quantity : 1 No. each / Wall blower
- 2.0 Specification :
- 2.1 Push button shall be of momentary contact push to actuate type, rated at 6 A at 415V AC.
- 2.2 Push button shall be fitted with self reset 1 NO + 1 NC Contacts
- 2.3 Push button shall be provided with integrally mounted legend plate. The legend plate shall be white anodized aluminium with black lettering.
- 2.4 The green push button shall be provided with 'START' legend plate and the red push button with 'RETRACT' legend plate.
- 2.5 Complete oil tightness shall be ensured in the actuator housing.
- 2.6 The push button shall be shrouded type,
- 2.7 The push button shall be suitable for an ambient temperature of 65°C.
- 2.8 The supplier shall enclose along with offer 3 copies of technical leaflet.
- 2.9 Push button shall be suitable for Ø30.5 mm hole.
- 3.0 Approx. weight : 0.2 kg/push button
- 4.0 Packing : To be packed in weather proof card board boxes and dispatched.
- 5.0 Internal inspection : 1. Limit switch type  
2. Electrical actuator  
3. Mechanical soundness.

Rev:05 Dt.16/03/2012

Note :2.9 Included.

Prepared  
(J SANKAR)

Checked  
(SHIVAM KUMAR GUPTA)

Approved  
(K.SRIDHARAN)