

Annexure-A

Sl. No	Material Code	Size	Class	Type	Description	Material Grade	Tender Qty	Quoted/ Not Quoted	Pattern Availability (Y/N)	Already Developed for BHEL (Y/N)	Time required for sample development (Should not exceed 4 months)
1	922016690000	6	300	FV	ARM	CF8M	125				
2	922010730000	10	300	FV	ARM	WCB	250				
3	922010700000	12	300	FV	ARM	WCB	200				
4	922017670000	14	300	FV	ARM	WCB	50				
5	922017690000	16	300	FV	ARM	WCB	100				
6	922010430000	10	300	FV	FLAP	WCB	250				
7	922010690000	12	300	FV	FLAP	WCB	200				
8	920342840000	3	300	GV	WEDGE	WCB	200				
9	922004060000	3	150	GV	WEDGE	CF8M	175				
10	920342830000	3	150	GV	WEDGE	WCB	600				
11	922010940000	4	150	GV	WEDGE	WCB	500				
12	922010960000	4	150	GV	WEDGE	CF8M	125				
13	922004050000	6	150	GV	WEDGE	CF8M	125				
14	922010890000	6	300	GV	WEDGE	WCB	200				
15	922009950000	8	150	GV	WEDGE	CF8M	50				
16	922010810000	8	150	GV	WEDGE	WCB	100				
17	922011130000	8	300	GV	WEDGE	WCB	500				
18	922011550000	8	300	GV	WEDGE	CF8M	30				
19	922011030000	10	150	GV	WEDGE	WCB	100				
20	922011090000	10	300	GV	WEDGE	WCB	300				
21	922011120000	10	300	GV	WEDGE	WCB	30				
22	922010990000	12	150	GV	WEDGE	WCB	100				
23	922011260000	12	300	GV	WEDGE	WCB	300				
24	922003950000	14	150	GV	WEDGE	WCB	60				
25	922003960000	16	150	GV	WEDGE	WCB	40				
26	922005330000	16	300	GV	WEDGE	WCB	225				

For more info
1

Annexure-A

Sl. No	Material Code	Size	Class	Type	Description	Material Grade	Tender Qty	Quoted/ Not Quoted	Pattern Availability (Y/N)	Already Developed for BHEL (Y/N)	Time required for sample development (Should not exceed 4 months)
27	922008420000	16	300	GV	WEDGE	WCB	20				
28	922006900000	18	150	GV	WEDGE	WCB	25				
29	922001580000	20	150	GV	WEDGE	WCB	50				
30	922017460000	22	300	GV	WEDGE	WCB	20				
31	920085220000	12	300	GV	YOKE	WCB	300				
32	922003620000	14	150	GV	YOKE	WCB	50				
33	922005230000	16	300	GV	YOKE	WCB	100				
34	922001590000	20	150	GV	YOKE	WCB	50				
35	922017530000	22	300	GV	YOKE	WCB	20				
36	920057850000				Valve Blower Body	WCB	1200				
Monthly Commitment in MT (Vendor to mention)											

Noted
17/11/2017

BHARAT HEAVY ELECTRICALS LIMITED
433, Industrial Complex
INDUSTRIAL VALVES PLANT GOINDWAL SAHIB

The drawings are not uploaded on this sight. For Drawings, the individual can request to send drawing by email. The email id for request of drawings is rajeshk@bhelivp.in.

[Phone No. 01859-224616](tel:01859-224616)

List Of Items

S. No	Row Labels	Drawig Number	Size	Class	Type	Description	Mat.	Tender Qty	Est./DSS Wt.	Total Weight
1	922016690000	2VZ04214084R/00	6	300	FV	ARM	CF8M	125	3.65	456
2	922010730000	3VZ01723420R/00	10	300	FV	ARM	WCB	250	10.3	2575
3	922010700000	3VZ01823459R/02	12	300	FV	ARM	WCB	200	14	2800
4	922017670000	3VZ02324672R/02	14	300	FV	ARM	WCB	50	19.00	950
5	922017690000	3VZ02224673R/00	16	300	FV	ARM	WCB	100	19.00	1900
6	922010430000	4VZ01726176P/00	10	300	FV	FLAP	WCB	250	26.5	6625
7	922010690000	4VZ01826218P/00	12	300	FV	FLAP	WCB	200	48	9600
8	920342840000	3VN04906599R/00	3	300	GV	WEDGE	WCB	200	4.7	940
9	922004060000	3VN33806598R/00	3	150	GV	WEDGE	CF8M	175	3.08	539
10	920342830000	3VN02506598R/00	3	150	GV	WEDGE	WCB	600	3.08	1848
11	922010940000	2VN03303379R/02	4	150	GV	WEDGE	WCB	500	5.5	2750
12	922010960000	2VN43803379R/02	4	150	GV	WEDGE	CF8M	125	5.50	688
13	922004050000	2VN33903304R/00	6	150	GV	WEDGE	CF8M	125	10.20	1275
14	922010890000	1VN01702860R/02	6	300	GV	WEDGE	WCB	200	12.4	2480
15	922009950000	1VN73402855R/01	8	150	GV	WEDGE	CF8M	50	16.30	815
16	922010810000	1VN00902855R/02	8	150	GV	WEDGE	WCB	100	16.3	1630
17	922011130000	2VN08903417R/02	8	300	GV	WEDGE	WCB	500	19.6	9800
18	922011550000	2VN49803417R/00	8	300	GV	WEDGE	CF8M	30	19.60	588
19	922011030000	2VN05703384R/02	10	150	GV	WEDGE	WCB	100	26	2600
20	922011090000	2VN06503393R/02	10	300	GV	WEDGE	WCB	300	36.6	10980
21	922011120000	2VN23803393R/02	10	300	GV	WEDGE	WCB	30	36.60	1098
22	922010990000	2VN04103380R/02	12	150	GV	WEDGE	WCB	100	41.7	4170
23	922011260000	2VN1050554R/01	12	300	GV	WEDGE	WCB	300	81.8	24540
24	922003950000	2VN31605973R/04	14	150	GV	WEDGE	WCB	60	64	3840
25	922003960000	2VN35005974R/03	16	150	GV	WEDGE	WCB	40	87.8	3512
26	922005330000	2VN43606124R/03	16	300	GV	WEDGE	WCB	225	119	26775
27	922008420000	2VN61606124R/02	16	300	GV	WEDGE	WCB	20	119.00	2380
28	922006900000	2VN56806281R/02	18	150	GV	WEDGE	WCB	25	107	2675
29	922001580000	2VN22405711R/04	20	150	GV	WEDGE	WCB	50	137	6850
30	922017460000	2VNE9614235R/00	22	300	GV	WEDGE	WCB	20	220.00	4400

Handwritten signature

List Of Items

S. No	Row Labels	Drawig Number	Size	Class	Type	Description	Mat.	Tender Qty	Est./DSS Wt.	Total Weight
31	920085220000	2VN10505553R/01	12	300	GV	YOKE	WCB	300	32	9600
32	922003620000	2VN31605939R/02	14	150	GV	YOKE	WCB	50	34	1700
33	922005230000	2VN43606112R/02	16	300	GV	YOKE	WCB	100	64	6400
34	922001590000	2VN22405714R/01	20	150	GV	YOKE	WCB	50	53.5	2675
35	922017530000	2VNE9614275R/01	22	300	GV	YOKE	WCB	20	196.00	3920
36	920057850000	12020100189/05				Wall Blower Body	WCB	1200	28.00	33600

Note: For Item Sl. No. 01, 04, 05, 30 & 35 the weights given are DSS weights. For rest of items it is our establish weight

Part furnished

VENDOR PERFORMANCE MONITORING AND RATING SYSTEM

The vendors shall be assessed with respect to the following main factors and calculated for each consignment/purchase order/ cumulative quantity from all consignments within the period of six months.

Rating	Weightage(%)
Quality	60
Delivery	30
Service	10

QUALITY RATING

Total Quality Rating will be as per formula given below.

$$\text{QUALITY RATING (QR)} = [(Q_1 + 0.75 \times Q_2 + 0 \times Q_3) \times 60] / Q$$

- Where Q - Quantity inspected
 Q₁ - Quantity accepted
 Q₂ - Quantity accepted with concession/ deviation/rectification
 Q₃ - Quantity rejected

The pre-inspection report (at supplier's works) shall include the quantity accepted after rework in Q₂ category.

DELIVERY RATING

Vendor shall be rated on delivery parameters whereas Delivery rating shall be 30 in case of adherence to PO delivery.

For non-adherence to PO Delivery (i.e delay in supply), marks to be deducted in proportion of delay to PO delivery.

$$\text{Deduction} = 30 * \text{delay in days} / \text{PO delivery in days.}$$

Note:

1. Delay is calculated on the date of GR/RR basis .
2. In cases, where delay is on account of BHEL in providing input, the delivery shall be extended with amendment to PO.
3. In case of rectification/replacement of item, the delivery is to be reckoned from the original supply date.

SERVICE RATING [SR, SR']

Service rating [SR'] out of 10 marks shall be given based on feedback from Quality/User department and Purchase department assessment of vendors. The service rating shall be 10 in case no negative feedback against the vendor for the given supply. Else, the service rating should be reduced proportionally based on the Demerit factor.

Rush Kumar

In case negative feedback (Substantiated by documentary evidence) is received from Shop Floor/Site on the supplies made, at a later date, demerit factor should be applied again accordingly.

Demerit factors for service rating shall be calculated based on % of rework and rejection [both taken separately and then added] as under:

% criteria	DF in case of Rework %
<2%	0
>2% and <5%	2
>5% and <10%	3
>10% and <15%	4
>15%	5

% criteria	DF in case of Rejection %
<0.5%	0
>0.5% and <2%	2
>2% and <5%	3
>5% and <10%	4
>10%	5

The SR' derived shall be updated by subtracting above demerit factor value, i.e. $SR = SR' - DF$. By virtue of $SR' < DF$ in any case, i.e. SR coming negative, it shall be considered as "0".

The Vendor Performance Rating (VPR) will be equal to total sum of QR, DR & SR.

$$\text{VENDOR PERFORMANCE RATING (VPR)} = \text{QR} + \text{DR} + \text{SR}$$

Based on the total score the vendor performance will be rated as below.

Total Score	Rating	Action
95-100	A1	Can be considered for award appreciation/commendation letter.
90-95	A	Vendor can be considered for self certification or for reduced witness points during inspection.
75-90	B	No action in normal case. If any deterioration comes to notice on analysis, the vendor shall be informed.
60-75	C	(i) Vendor/ processes shall be subject to thorough analysis for identification of areas for improvement. (ii) Enquiry to be sent only after concerned MM Head approval
<60	D	To be dealt in accordance with the extant guidelines on suspension of Business dealings with Suppliers/contractors.

Prashant Kumar

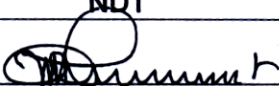
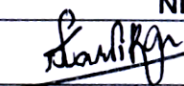

**PROCEDURE FOR RADIOGRAPHIC EXAMINATION OF CASTINGS
USED FOR VALVES AND BOILERS.**

Prepared By	Reviewed & Approved By
M.MANIMOHAN DY.MANAGER LEVEL II NDT	R.J.PARDIKAR AGM Sr.LEVEL III NDT
	

EFFECTIVE FROM 18-04-2009

CONTROLLED / INFORMATION COPY

ISSUED TO	ISSUED ON	CONTROL NO.	ISSUED BY



RECORD OF REVISION

Rev No	Revision Date	Revision of Details
05	01-06-1993	Revised in its entirety
06	12-06-1997	Procedure BHE:NDT:V:RT:9 Rev. 01 merged with this procedure And revised to its entirety.
07	18-04-2009	2.0, 5.1, 8.1.1, 13.1, 15.1, 18.1, Annexure A , B, C, D, E, F – Revised.



1.0 SCOPE

1.1 This procedure describes the testing method and acceptance standard for the radiographic examination of steel castings of materials ASTM A 216 - WCB, WCC, A 217 -WC6, WC9, ASTM A351 Gr.- CF8M, Components covered under API 6A, thickness ranging up to 305mm and pertaining to conventional valves, TOA valves, Safety and Safety Relief Valves, Oil Field Equipments, and Boiler Components.

2.0 REFERENCES

2.1 ASME Boiler and Presser Vessel code - Section-V / VIII Div I /2007 / 2008 Addenda

2.2 ASME B 16.34 / 2004

2.3 ASTM E 94 / 2000

2.4 API-6A / 2005, 6D / 2008,16C / 1993, 17D / 1992.

3.0 EQUIPMENT

3.1 Radiation sources

3.1.1 The radiation energy (X-rays upto 6 Mev, Iridium 192, Cobalt 60) employed for any Radiographic technique shall achieve the Density and IQI image requirements.

3.2 Films

3.2.1 Industrial Radiographic Film shall be used. Generally the following brands of film or equivalent shall be used for radiography:

- a) Agfa -Gevaert D7/(Laser D7)/D5/(Laser D5)
- b) Kodak Industrex A/AA 400/T/M

3.3 Screen

3.3.1 Lead intensifying Screens shall be used for radiography. Fluorescent screen shall not be used. Minimum thickness of the Lead Screen shall be 0.10/0.15mm for Ir.192 and 0.20/0.25mm for Co.60.

4.0 SURFACE CONDITION

4.1 The surface to be radiographed shall have a relatively even surface to allow proper interpretation of the radiograph. All deep surface pits of casting shall be dressed smoothly before radiography. Fettling operation shall be done before radiography.

5.0 RADIOGRAPHIC SENSITIVITY

5.1 Radiography shall be performed with a technique to achieve the sensitivity of **2-2T** . Selection of Image Quality Indictor (IQI) shall be based on the table 2 in Annexure -A .

5.2 If ASTM Wire Type IQI is used, the set of wires used shall be identified with the material with which the wire is made and their number. The set shall contain a wire equivalent to 2% of the thickness being radiographed.

5.3 The material of the IQI shall be radiographically similar to the object being radiographed. If this material is not available the IQI of the required dimensions, but of lower absorption material may be used. IQI shall conform to Recommended Practice SE 1025/SE 747.

5.4 Placement of IQI

5.4.1 Wherever possible, the IQI shall be placed on the source side of the section being



examined. For double wall single image technique, IQI may be placed on film side with identification 'F', if hand placement on source side is impracticable.

6.0 NUMBER OF IQI

6.1 When one or more film holders are used for an exposure, at least one IQI image shall appear on each radiograph except as outlined in 6.3 and 6.4.

6.2 If the requirement of 14.0 is met by using more than one IQI, one shall be representative of the lightest area of interest and the other shall be of the darkest area of interest; the intervening densities on the radiograph shall be considered as having acceptable density.

6.3 For cylindrical/spherical castings where the source is placed on the axis/centre of the object for a single exposure, at least three IQI shall be placed spacing approximately 120 degree apart under the following conditions;

6.3.1 When a complete circumference is radiographed using one or more film holders or

6.3.2 When a section or sections of the circumference, where the length between the ends of the outermost sections span 240 or more degree is radiographed using one or more film holders. Additional film locations may be required to obtain necessary penetrameter spacing.

6.4 For cylindrical/Spherical castings of the circumference of a cylindrical/spherical casting is radiographed placing source at the axis/centre of the component for a single exposure, at least three IQI's shall be placed at each end of the span of the circumference radiographed and one in the approximate centre of the span,

6.4.1 When a section of the circumference, the length of which is greater than 120 degree and less than 240 degree is radiographed using just one film holder, or

6.4.2 When a section or sections of the circumference, where the length between the ends of outermost sections span less than 240 degree is radiographed using more than one film holder.

6.5 In order to maintain the continuity of records involving subsequent exposures, all radiograph exhibiting IQI which qualify the techniques permitted in accordance with 6.3 and 6.4 shall be retained.

6.6 When an array of objects in a circle is radiographed, at least one IQI shall be seen on each object image.

7.0 RADIOGRAPHY COVERAGE

7.1 The castings sections to be radiographed shall be as per the sketches shown in Annexure F. However all the sample castings shall be radiographed for the entire accessible region.

8.0 GEOMETRICAL UNSHARPNESS (μ_g)

8.1.1 When required by the referencing code section, Geometric Un-sharpness of the radiograph shall not exceed the following and source to film distance shall be selected accordingly.

TABLE - 1

MATERIAL THICKNESS	μ_g Max.
Under 50.0 mm	0.51 mm
Over 50.0 to 75.0 mm	0.76 mm
Over 75.0 to 100.0mm	1.02 mm
Greater than 100.0 mm	1.78 mm

Material thickness is the thickness on which IQI is based.



- 8.2 For other cases, source to film distance shall be selected such that Geometric Unsharpness shall not exceed 1.78mm.
- 8.3 Final acceptance of the radiograph shall be based on the achievement of requisite sensitivity.
- 9.0 LOCATION MARKER
- 9.1 Location markers which are to appear as radiographic images on the film, shall be placed on the part, not on the exposure holder/cassette. Their location shall be permanently marked on the surface of the part being radiographed when permitted or on a map in a manner permitting the area of interest on a radiograph to be accurately traceable to its location on the part for the required retention period of the radiograph. Evidence also shall be provided on the radiograph that the required coverage of the region being examined has been obtained.
- 9.2 Location markers shall be placed as in Annexure F
- 10.0 EXAMINATION
- 10.1 Radiographic technique: A single wall exposure technique shall be used whenever practical. When it is not practical to use a single wall technique a double wall technique shall be used (for cylindrical/spherical castings where outside diameter is less than 90 mm). An adequate number of exposures shall be made to demonstrate that the required coverage has been obtained.
- 10.2 For double wall viewing, only a source side IQI shall be used.
- 11.0 INFORMATION ON RADIOGRAPH
- 11.1 The following information shall appear on the radiograph as a permanent image.
- 11.1.1 Job Number i.e. serial number given for the part as per radiographic details register.
- 11.1.2 Segment number as per the shooting sketch of the part.
- 11.1.3 Image Quality Indicators.
- 11.1.4 Date of Radiography.
- 11.1.5 Name of the company/BHEL
- 11.1.6 If the radiograph is taken after any local repair revealed in the original radiograph, letters R1, R2 etc. shall be kept after the job number to indicate that the radiograph is after the repair and the suffix 1,2 etc. will specify the number of times repair is carried out. The radiographs taken after repair shall be submitted along with original. The repaired area shall be identified by placing lead arrows. Radiographic identification and IQI shall not be placed on the repaired region.
- 12.0 QUALITY OF RADIOGRAPHS
- 12.1 All radiographs shall be free from mechanical, chemical or other blemishes
- 12.2 Scattered Radiation: To check the back scattered radiation, a lead symbol 'B', of 13.0mm in height and 1.6mm in thickness shall be attached to the back of each film holder.
- 12.3 Excessive Scatter: If the light image of 'B' appears on the darker background of the radiograph, protection from back scatter is insufficient and the radiograph shall be considered unacceptable. A dark image of 'B' on a lighter background is not a cause for rejection.



13.0 RADIOGRAPHIC DENSITY

13.1 The transmitted film density through the radiographic image of the body of the appropriate IQI's and the area of interest shall be for single film viewing- 1.5 minimum and 4.0 maximum
For Super imposed viewing of double film each film shall have 1.00 minimum and 2.5 maximum and with double film 4.0 maximum

13.2 Either a densitometer or a step wedge comparison film shall be used for density measurements

14.0 DENSITY VARIATION

14.1 If the density of the radiograph anywhere through the area of interest varies by more than -15% or +30% from the density through the body of IQI, within the minimum/maximum allowable density ranges specified in 13.1, then an additional IQI shall be used for each exceptional area or areas and the radiograph retaken. When calculating the allowable variation in density, the calculation may be rounded off to the nearest 0.1 within the range specified in 13.1.

15.0 ACCEPTANCE STANDARDS

15.1 Evaluation of defects shall be carried-out as per ASTM E-446 for Steel Castings upto 50mm thickness, as per ASTM E-186 for steel castings - heavy walled (50mm to 115mm) and as per ASTM E-280 for heavy walled steel castings, wall thickness 115mm through 305mm.

15.2 Acceptance standards for various components are given in annexure B to D.

16.0 NDE PERSONNEL

16.1 Radiography shall be performed by personnel qualified as minimum level I and Evaluation by Level II / III in accordance with Procedure BHE:NDT:G:CRT.

17.0 REPORTING, RECORDING AND UP KEEPING OF THE RADIOGRAPHS

17.1 Results of radiographic examination shall be reported in formats approved by Head/NDTL-BHEL.

17.2 All the radiographs shall be clearly identified with serial numbers which can be linked up with the casting which bears the same serial number as that of radiographs.

17.3 The radiograph number shall be punched just below the heat numbers and encircled with white paint and the location number shall be legibly painted on the castings with white paint.

17.4 Radiographs of castings pertaining to API 6A - PSL 3 and 4 and of welds pertaining to API 6A - PSL 2, 3 and 4 classification shall be retained for a period of minimum 5 years. Other radiographs will be retained till the manufacturing is completed or up to 3 years from the date of radiography, whichever is earlier.

18.0 SAFETY

18.1 Applicable safety precautions shall be followed in accordance with Procedure BHE:NDT:G:SFT



ANNEXURE-A
Table-2

Material Thickness, IQI designations and Essential hole / Wire diameter .

Nominal Single wall thickness range (mm)	Image Quality Indicator							
	Source side				Film side			
	Desgn	Essl. Hole	Wire		Desgn	Essl. Hole	Wire	
No			Dia(mm)	No			Dia(mm)	
Up to 6.4 incl.	12	2T	5	0.20	10	2T	4	0.16
Over 6.4 through 9.5	15	2T	6	0.25	12	2T	5	0.20
Over 9.5 through 12.7	17	2T	7	0.33	15	2T	6	0.25
Over 12.7 through 19.0	20	2T	8	0.41	17	2T	7	0.33
Over 19.0 through 25.4	25	2T	9	0.51	20	2T	8	0.41
Over 25.4 through 38.1	30	2T	10	0.64	25	2T	9	0.51
Over 38.1 through 50.8	35	2T	11	0.81	30	2T	10	0.64
Over 50.8 through 63.5	40	2T	12	1.02	35	2T	11	0.81
Over 63.5 through 101.6	50	2T	13	1.27	40	2T	12	1.02
Over 101.6 through 152.4	60	2T	14	1.60	50	2T	13	1.27
Over 152.4 through 203.2	80	2T	15	2.03	60	2T	14	1.60
Over 203.2 through 254.0	100	2T	16	2.54	80	2T	15	2.03
Over 254.0 through 304.8	120	2T	17	3.20	100	2T	16	2.54

ANNEXURE-B

RADIOGRAPHIC ACCEPTANCE STANDARDS FOR CASTINGS OF CONVENTIONAL VALVES, TOA DESIGN VALVES AND BOILER CASTINGS. (AS PER ASME B 16.34)

B1.0 Acceptance of pressure containing castings up to and including 600 PSI(g) or 40 atm. primary service rating shall be based on the following:

B1.1 Wall thickness less than 50 mm.

The following comparative plates of ASTM E 446 define acceptable indications as follows:-

Discontinuity type	Acceptable comparative plate	
	Category	Level
Gas	A	A2
Sand	B	B3
Shrink Type-1	C	CA2
Shrink Type-2	C	CB3
Shrink Type-3	C	CC3
Shrink Type-4	C	CD3
Hot tear & Cracks	D&E	None
Inserts (chills, chaplets)	F	None
Mottling	G	Reference Purpose only

B1.2 The following comparative plates of ASTM E 186 shall be acceptable for Wall thickness from 50mm up to 115 mm and of ASTM E 280 shall be acceptable for wall thickness from 115 mm through 305mm.

Discontinuity type	Acceptable comparative plate	
	Category	Level
Gas porosity	A	A3
Sand and slag inclusions	B	B3
Shrink Type-1	C	CA3
Shrink Type-2	C	CB3
Shrink Type-3	C	CC3
Cracks	D	None
Hot tear	E	None
Inserts	F	None



B2.0 ACCEPTANCE OF PRESSURE CONTAINING CASTINGS OVER 600 PSI(G) (40 atm) PRIMARY SERVICE PRESSURE RATING SHALL BE BASED ON THE FOLLOWING:

B2.1 Wall thickness less than 51mm.
The following comparative plates of ASTM E 446 define acceptable indications as follows:-

Discontinuity type	Acceptable comparative plate	
	Category	Level
Gas	A	A1
Sand	B	B2
Shrink Type-1	C	CA1
Shrink Type-2	C	CB2
Shrink Type-3	C	CC2
Hot tear & Cracks	D&E	None
Inserts (chills, chaplets)	F	None
Mottling	G	Reference Purpose only

B2.2 The following comparative plates of ASTM E 186 shall be acceptable for Wall thickness from 51mm upto 115mm and of ASTM E 280 shall be acceptable for wall thickness from 115mm through 305mm.

Discontinuity type	Acceptable comparative plate	
	Category	Level
Gas porosity	A	A2
Sand and slag inclusions	B	B2
Shrink Type-1	C	CA2
Shrink Type-2	C	CB2
Shrink Type-3	C	CC2
Cracks	D	None
Hot tear	E	None
Inserts (chills, chaplets)	F	None

B3.0 Butt welding ends shall be free from shrinkage and hot tear. Gas hole/porosity and sand inclusion shall be limited to level A1 and B1 respectively.

B4.0 The acceptance Standard for yoke, yoke clamp and wedge/Disc shall be level-III of E446/E186/E280. No crack, hot tear or unfused chaplet/insert is permitted.

B5.0 Acceptance of weld repairs of steel casting shall be as follows:-

Weld repair portions of castings that are shown by radiography to have any of the following type of discontinuities shall be unacceptable.

- A) Any type of crack or zone of incomplete fusion or incomplete penetration.
- B) Any other elongated indication which has a length greater than
 - i) 6.00mm for 't' upto 19mm inclusive
 - ii) 1/3t for 't' from 19mm to 57mm inclusive
 - iii) 19 mm for 't' over 57mm where 't' is the thickness of the repaired portion.
- C) Any group of indications in line that have an aggregate length greater than 't' in a length of 12t except when the distance between the successive indication exceeds 6 L where 'L' is the length of the longest indication in the group.
- D) Rounded indication in excess of that shown as acceptable in rounded indication chart given in annexure 4 of ASME Section VIII, Division 1



ANNEXURE -C
RADIOGRAPHIC ACCEPTANCE STANDARDS FOR SAFETY AND SAFETY RELIEF VALVE COMPONENTS.

C1.0 Radiographic acceptance standard for area marked as critical in the respective casting drawing shall be as follows:-

C1.1 The following comparative plates of ASTM E-446 for thickness upto 51mm and ASTM-E 186 for thickness from 51mm to 115mm shall define the acceptable indication as mentioned below:

Discontinuity type	Acceptable comparative plate	
	Category	Level
Gas	A	A3
Sand	B	B3
Shrink Type-1	C	CA3
Shrink Type-2	C	CB3
Shrink Type-3	C	CC3
Shrink Type-4	C	CD4
Hot tear & Cracks	D & E	None
Inserts (chills, chaplets)	F	None
Mottling	G	Reference purpose only

C1.2 Other areas shall be accepted against the comparative plate as indicated below depending upon the thickness.

Discontinuity type	Acceptable comparative plate	
	Category	Level (ASTM E 446 / E 186)
Gas porosity	A	A4/A4
Sand and slag inclusions	B	B4/B4
Shrink Type-1	C	CA4/CA4
Shrink Type-2	C	CB4/CB4
Shrink Type-3	C	CC4/CC4
Shrink Type-4	C	CD4/ -
Hot tear & Cracks	D & E	None
Inserts (chills, chaplets)	F	None
Mottling	G	Reference purpose only

C2.0 Butt welding ends shall be free from shrinkage and Hot Tear. Gas Hole/Porosity and sand inclusion shall be limited to A1 and B1 respectively.

C3.0 Acceptance of weld repairs of steel castings shall be as follows:-

C3.1 Weld repair portions of castings that are shown by radiography to have any of the following type of discontinuity shall be unacceptable:

A. Any type of crack or zone of incomplete fusion or incomplete penetration.

B. Any other elongated indication which has a length greater than

- i) 6.00 for 't' upto 19mm inclusive.
- ii) 1/3 t for 't' from 19mm to 57mm inclusive.
- iii) 19mm for 't' over 57mm where 't' is the thickness of the repaired portion.

C. Any group of indications in line that have an aggregate length greater than 't' in a length of 12t' except when the distance between the successive indication exceeds 6L where 'L' is the length of the longest indication in the group.

D. Rounded indication in excess of that shown as acceptable in Appendix 4 of ASME Section VIII, Division 1.



ANNEXURE - D

D1.0 ACCEPTANCE STANDARDS FOR OIL FIELD EQUIPMENTS

D1.1 Castings

D1.1.1 The following comparative plate of ASTM E 446 for thickness less than 51mm, ASTM E 186 for thickness from 51mm to 114mm and ASTM E 280 for thickness from 114 through 305 mm shall define the acceptable criteria depending upon the section thickness being examined.

Discontinuity type	Acceptable comparative plate	
	Category	Level
Gas	A	2
Sand	B	2
Shrinkage(all types)	C	2
Hot tear	D	None
Crack	E	None
Inserts(chills, chaplets)	F	None
Mottling	G	None

D1.2 Hot worked Parts of PSL-1,2 , 3 and 3G

D1.2.1 No type of cracks, laps or bursts.

D1.2.2 No elongated indications with length exceeding

- (a) 6.4 mm for thickness upto 19mm.
- (b) 0.33 of thickness for thickness 19mm upto 57mm.
- (c) 19mm for thickness over 57mm.

D1.2.3 No group of indications in a line that have an aggregate length greater than the thickness in a length of twelve times the thickness.

D1.3 Hot worked material of PSL-4

D1.3.1 No type of cracks, laps or bursts.

D1.3.2 No elongated indications having length exceeding 6.4mm.

D1.3.3 No more than 2 indications separated by less than 13.0 mm.

D1.4 Welds:PSL-1,2 , 3 and 3G:

D1.4.1 No type of crack, zone of incomplete fusion, or incomplete penetration.

D1.4.2 No elongated slag inclusion which has a length equal to or greater than

- a) 6.4mm for weld thickness less than 19mm inclusive.
- b) 1/3 times the thickness for weld thickness from 19mm to 57mm.
- c) 19mm for weld thickness greater than 57mm.

D1.4.3 No group of slag inclusions in a line having an aggregated length greater than the weld thickness, 'T', in any total weld length of 12T, except when the distance between successive inclusion exceeds six times the length of the longest inclusion.

D1.4.4 No rounded indications in excess of that specified in rounded indication chart, Appendix 4 of ASME Section VIII, Division 1.

ANNEXURE E

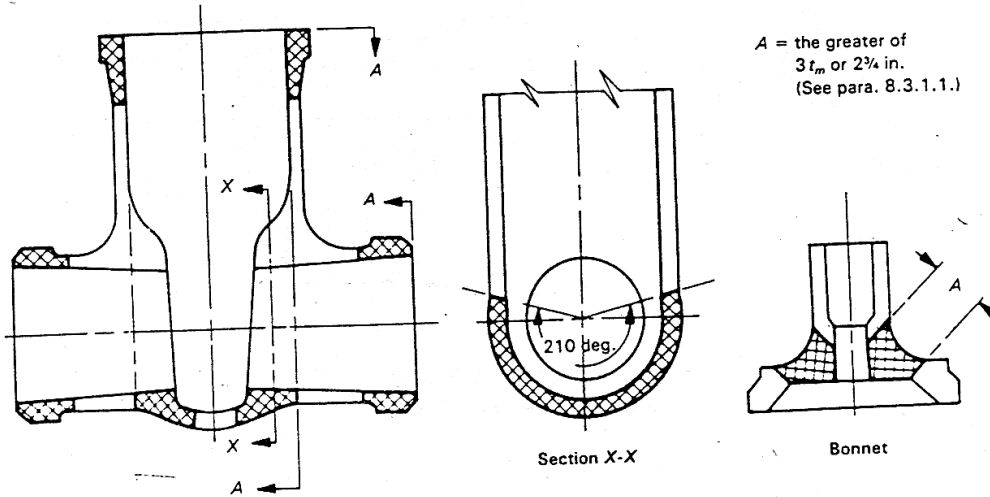

GATE BODY (PRESSURE SEAL BONNET)

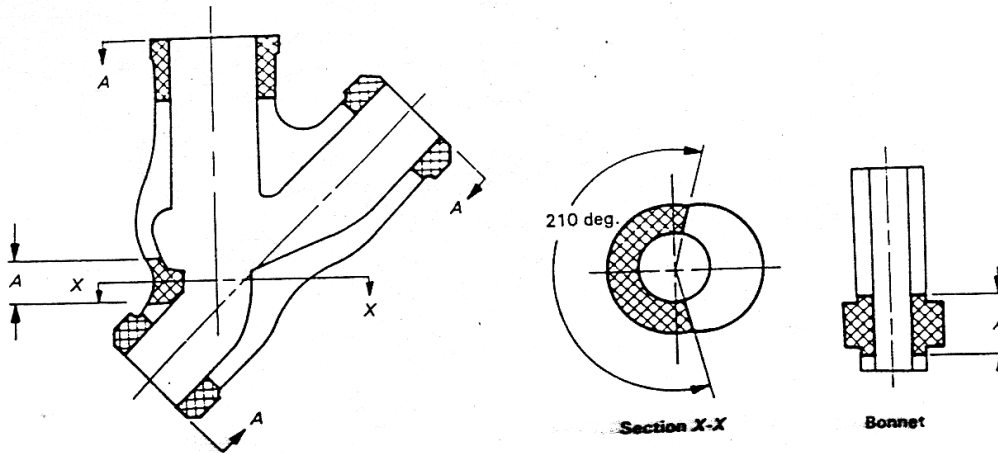

Y-PATTERN GLOBE BODY(PRESSURE SEAL BONNET)

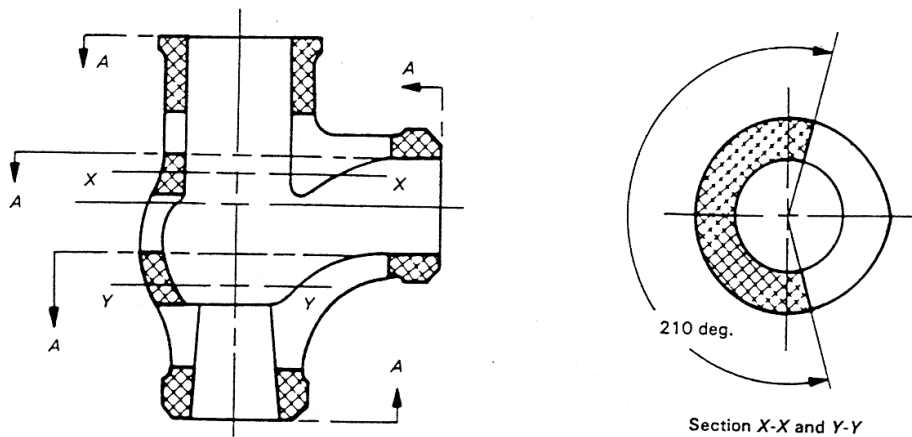

ANGLE BODY (PRESSURE SEAL BONNET)
BONNET SAME AS Y-PATTERN GLOBE

ANNEXURE-E

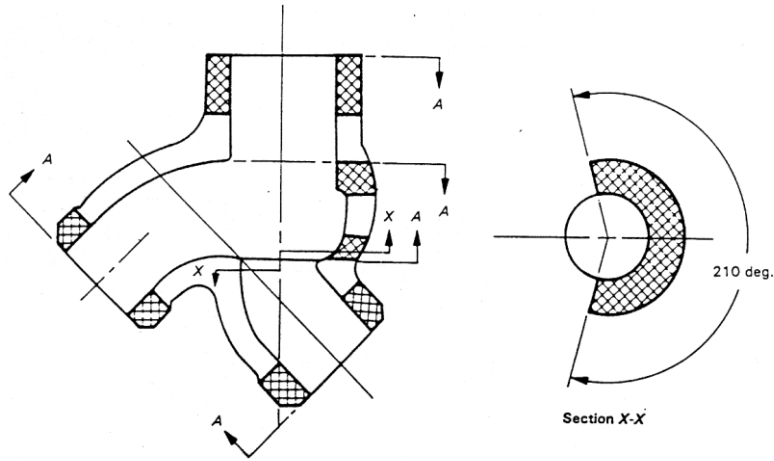

ELBOW DOWN (PRESSURE SEAL BONNET)

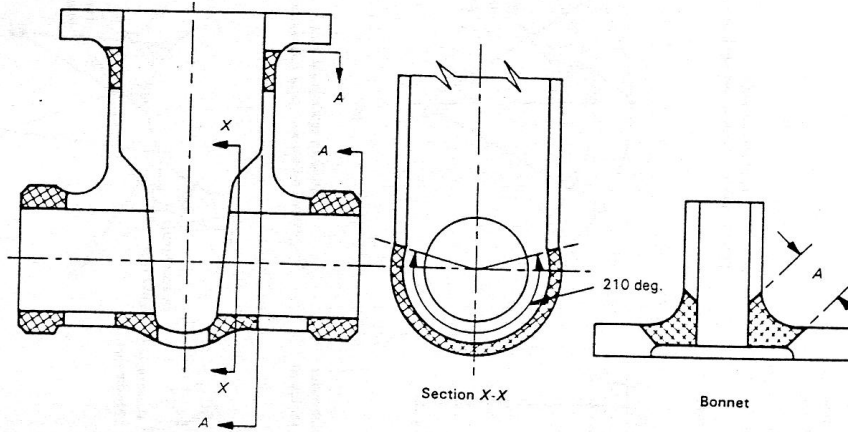

GATE BODY (FLANGED BONNET)

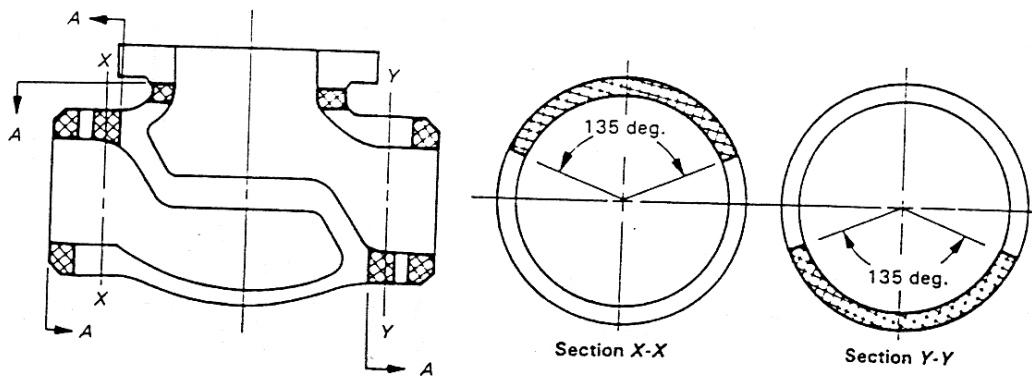

GLOBE BODY (FLANGED BONNET)

ANNEXURE - F

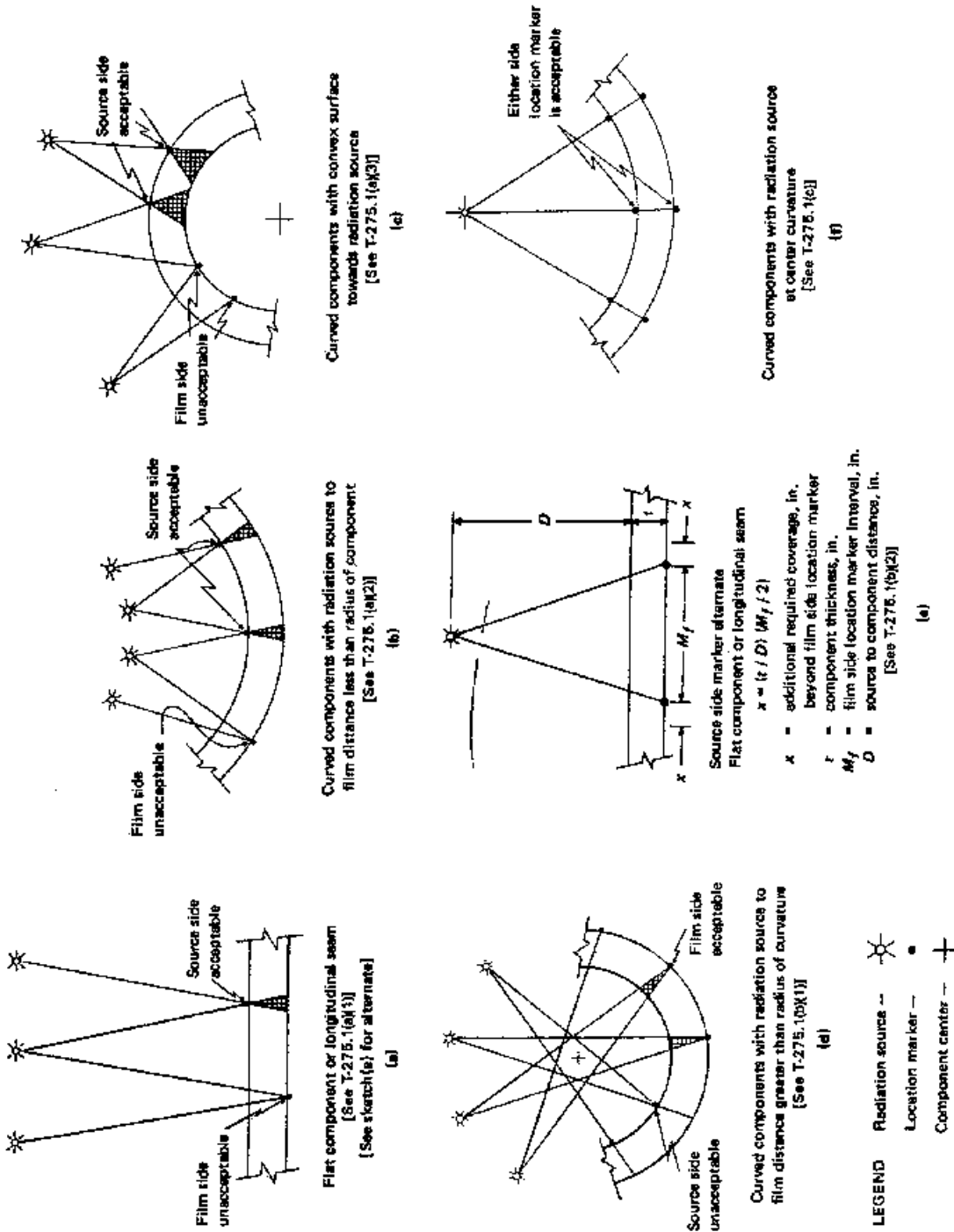

LOCATION MARKER SKETCHES



Bharat Heavy Electricals Limited

433, Ind. Valves Plant, GOINDWAL SAHIB (Distt. Amritsar)-143 423.

Annexure D

BHE: IVP: RT: PR Rev 03

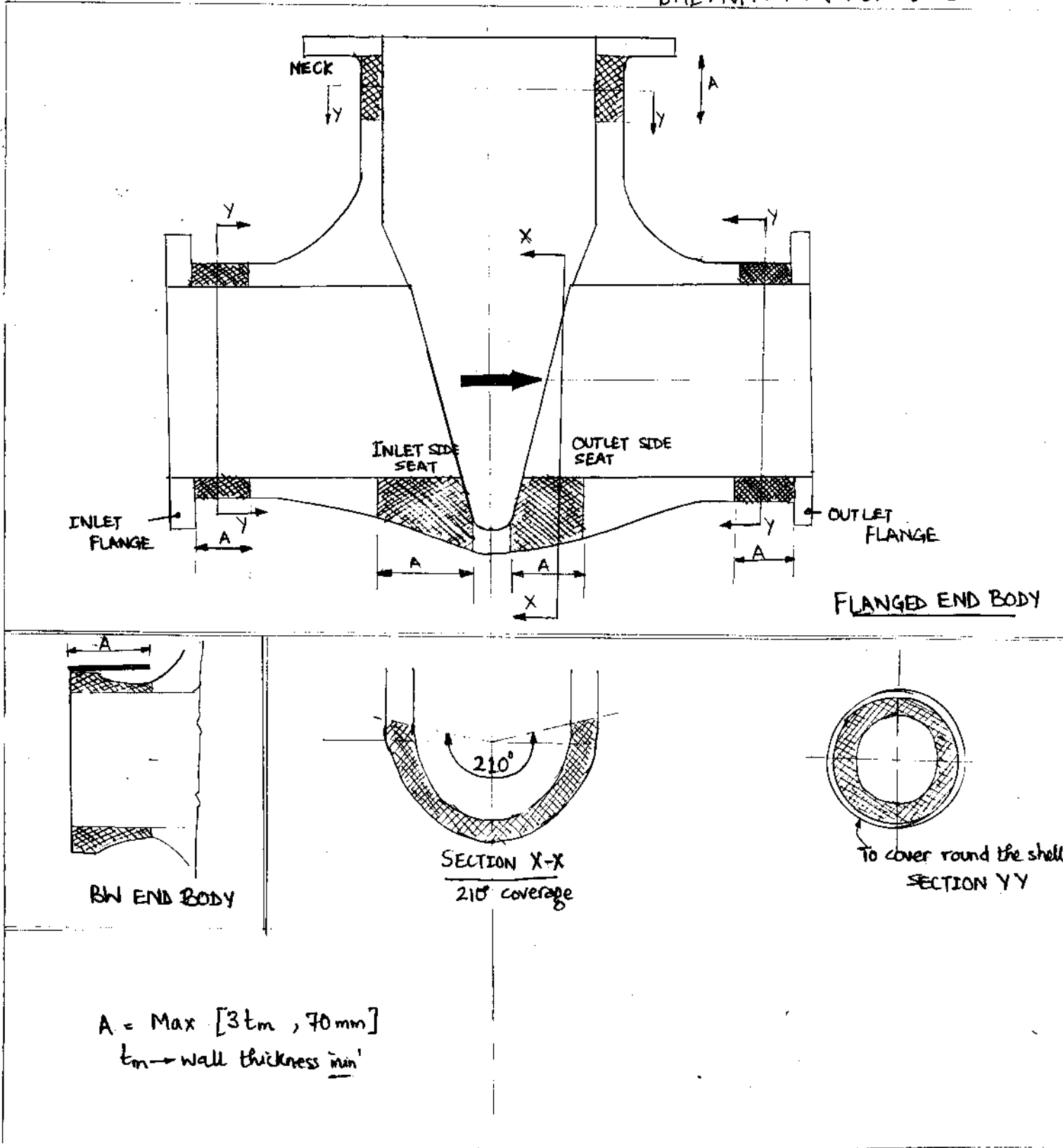



Bharat Heavy Electricals Limited

433, Ind. Valves Plant, GOINDWAL SAHIB (Distt. Amritsar)-143 423.

SHOOTING LOCATION DESIGNATION

- AT NECK : N1, N2, N3, N4,
- AT INLET FLANGE PIPE : A1, A2, A3, A4,
- AT INLET SIDE SEAT : SA1, SA2, SA3, SA4,
- AT OUTLET SIDE SEAT : SB1, SB2, SB3, SB4,
- AT OUTLET FLANGE PIPE : B1, B2, B3, B4,
- * AT INLET FLANGE FACE : FA1, FA2, FA3, FA4,
- * AT OUTLET FLANGE FACE : FB1, FB2, FB3, FB4,
- * FOR FLANGED END BODIES ONLY



Bharat Heavy Electricals Limited

433, Ind. Valves Plant, GOINDWAL SAHIB (Distt. Amritsar)-143 423.

BHE: IVP: RT: PR: Rev 03

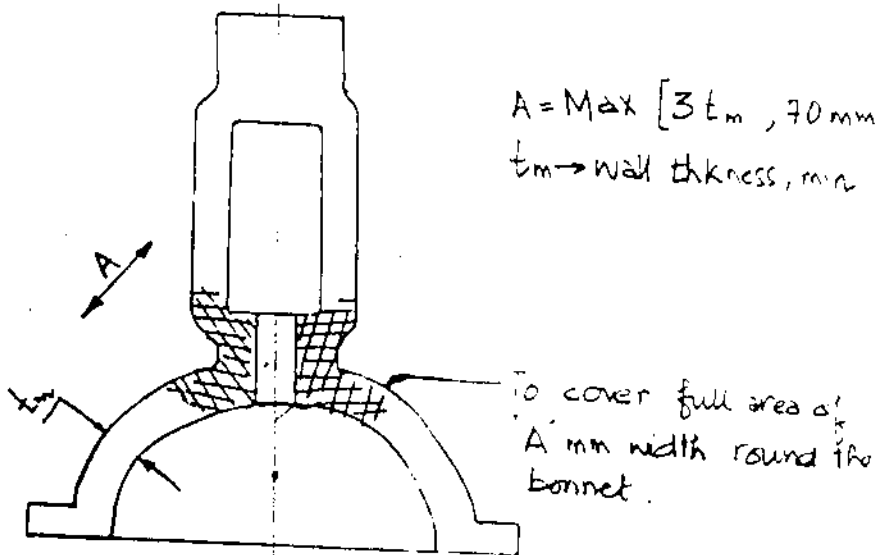

SHOT DESIGNATION AS 1, 2, 3, 4, ...

SHOOTING SKETCH OF GATE VALVE YOKE / BONNET

Regd. Office : 'BHEL HOUSE, Siri Fort, New Delhi-110 049.

Page 15 of 20



Bharat Heavy Electricals Limited

433, Ind. Valves Plant, GOINDWAL SAHIB (Distt. Amritsar)-143 423.

BHEZIVR: RT: PR: Rev 03

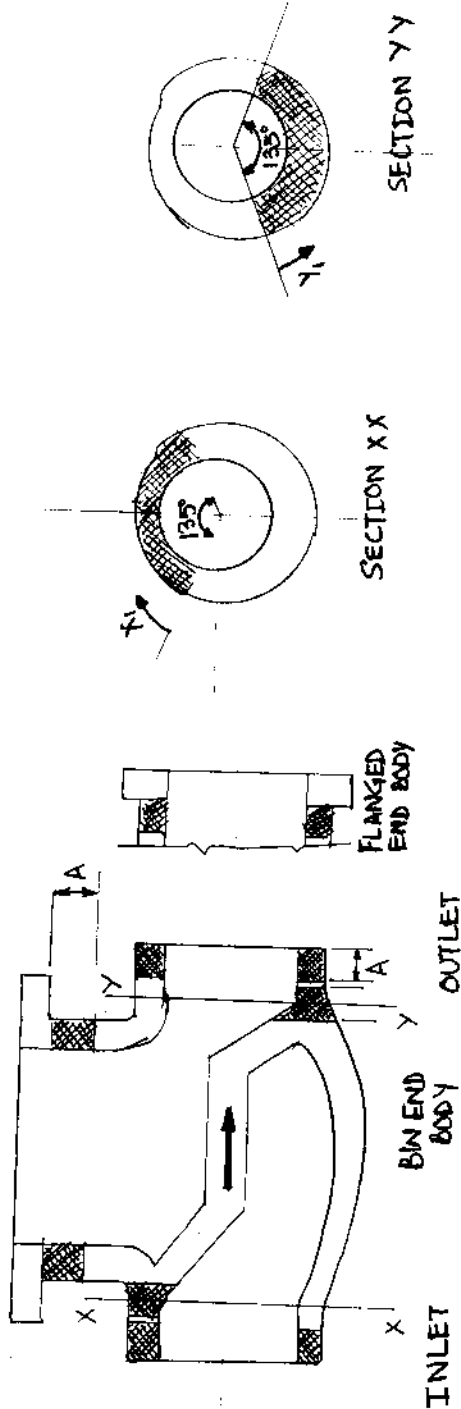

$$A = \text{Max} \{ 3.t_m, 70\text{mm} \}$$

t_m → min. wall thickness, mm

SHOOTING LOCATION DESIGNATION

SHOOTING LOCATION	DESIGNATION
AT NECK	N1, N2, N3, ...
AT INLET END	A1, A2, A3, ...
AT OUTLET END	B1, B2, B3, ...
AT SECTION XX	X1, X2, ...
AT SECTION YY	Y1, Y2, ...



Bharat Heavy Electricals Limited

433, Ind. Valves Plant, GOINDWAL SAHIB (Distt. Amritsar)-143 423.

: BHE: E.V.P: RT: PR Rev 3

SPROCKET SKETCH OF GOR LE

$A = \text{max} [2t_m, 70 \text{ mm}]$

$t_m = \text{min thickness, mm}$

To cover full area round the bonnet

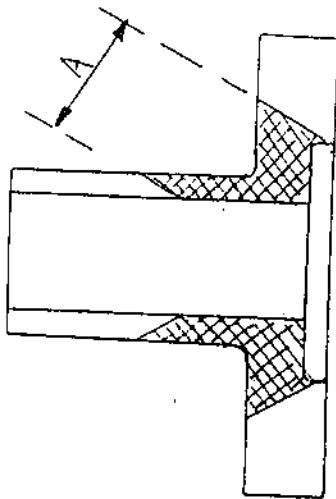

Regd. Office : 'BHEL HOUSE, Siri Fort, New Delhi-110 049.



Bharat Heavy Electricals Limited

433, Ind. Valves Plant, GOINDWAL SAHIB (Distt. Amritsar)-143 423.

BHE: IVP: RT: PR REV 03

SHOOTING SKETCH OF FLAP VALVE BODY

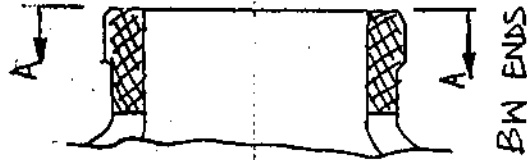

SHOOTING LOCATION DESIGNATION

SHOOTING LOCATION	DESIGNATION
AT NECK	N1, N2, N3, ...
AT INLET PIPE	A1, A2, A3, ...
AT INLET BW END	FA1, FA2, ...
AT OUTLET PIPE	B1, B2, B3, ...
AT OUTLET BW END	FB1, FB2, FB3, ...
AT SEAT	S1, S2, S3, ...

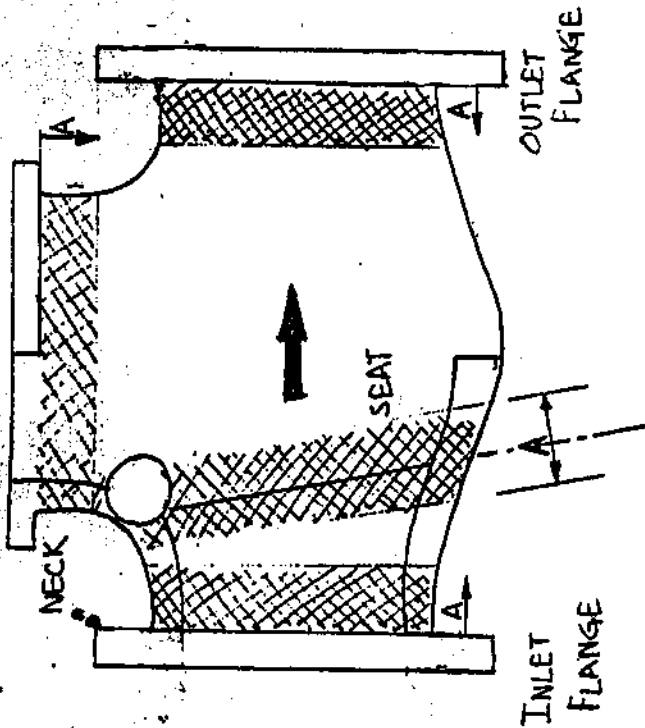

Regd. Office : BHEL HOUSE, SIRI Fort, New Delhi-110 049.



Bharat Heavy Electricals Limited

433, Ind. Valves Plant, GOINDWAL SAHIB (Distt. Amritsar)-143 423.

DIRECTION AND SHOT LOCATION

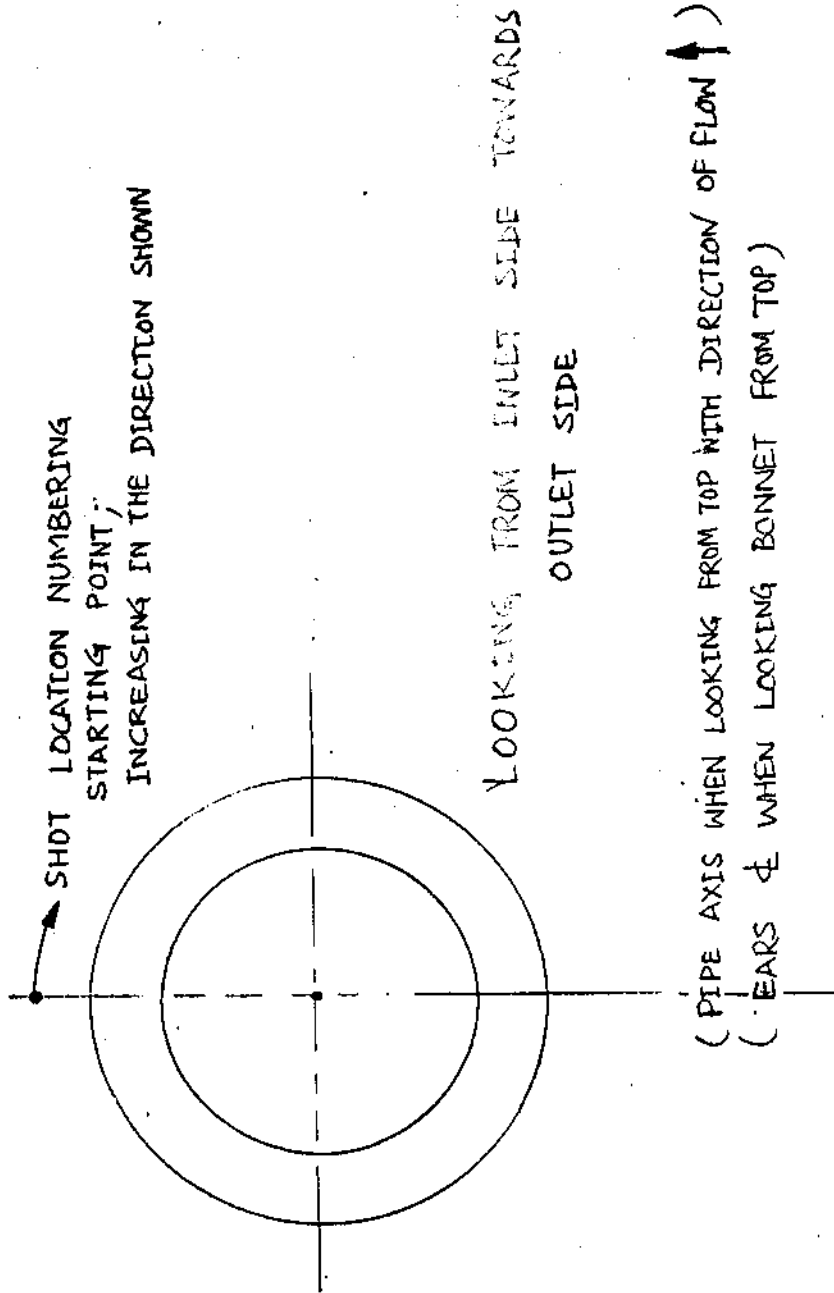

Regd. Office : 'BHEL HOUSE, Siri Fort, New Delhi-110 049.

Product : **STEEL CASTINGS.(VALVES)**Document No: **TDC:0:412**Rev No : **18**Effective Date: **25.01.2012**

Page- 1 of 7

Revision record: Rev 16: 27.04.2011 (1) Modified in entirety.

Rev.17 – 1) Cl.7.0 Table-1 NDE requirements, 2) Cl.7.1, Cl.9, Cl.11.0 – Revised. RT zone Sketch added.

Rev.18 – 1) Cl.7.0 Table-1 Wedge NDE changed, 2) Cl.9.0 – PED requirements for welding & NDE added.

1.0 MATERIAL:

Specification : ASME / ASTM {Latest on date of Purchase Order (PO)}:
 CARBON STEEL (CS) : SA / ASTM A216 WCB, WCC & 352 LCB , LCC
 ALLOY STEEL (AS) : SA / ASTM A217 WC6, WC9, C12A.
 STAINLESS STEEL (SS): SA / ASTM A351 CF3M,CF8,CF8C & CF8M.
 Additional Requirement : As listed below(Supplementary to Specification)
 Size, Qty, Grade/Class : As per Purchase order & Drawing / Pattern.

2.0 CHEMICAL COMPOSITION AND PROCESS:

Melting: As per the Specification, Fully Killed.

Carbon= 0.25% maximum : for SA / ASTM A216 WCB only.

Carbon= 0.15% maximum : for SA / ASTM A217 WC6 & WC9 (For the castings used in QCNRV, CRHNRV, TOA Valves & Conventional valves having contours for welding.)

Product Analysis on test bar for each melt including residual elements shall be carried out.

Additional requirements for API-6D materials:

CS: Carbon=0.23% max.(in ladle) and 0.25% max.(in Product analysis)

Carbon Equivalent=0.43 max.(in ladle) and 0.45 max.(in Product analysis)

Carbon Equivalent=%C+(%Mn/6)+(Cr+%Mo+%V)/5+(%Ni+%Cu)/15

SS: Carbon=0.03% max. except as below.

Carbon=0.08% max.for stabilized steels with Nb >10xC.and

for stabilized steels with Nb and Ta mass of (Nb+Ta)>8xC.

3.0 DIMENSIONS AND TOLERANCES:

Tolerances as per the Drawing.

Non tolerance Dimensions for valve components as per the Drawing:VL:STDC:023 (Latest)

4.0 HEAT TREATMENT :(HT)

CS. Castings of High Pressure Valve.(Cl.1500 & above),QCNRV & CRHNRV: Shall be in Annealed Condition.

AS. Castings: Normalized and Tempered.

Normalizing Temperature: for SA/ASTM A217 WC6, WC9: 920-950 °C and for C12A: 1050-1080 °C.

Tempering temperature (Minimum): SA/ASTM A217 WC6: 680°C; WC9: 720 °C; C12A: 750-780°C

Others: Heat Treated as per the Specification.

5.0 MECHANICAL TESTS:

Test bars to be cast integral with the casting or separately. If cast separately, they shall be cast at the same time as the castings and from the same ladle. A metal strip with heat number stamped shall be fused with the test bar during casting, to maintain traceability. If one(1) casting is made from more than one heat, separate test bars for each cast to be poured & all test bars shall satisfy the requirements. Following tests to be conducted per heat / Heat treatment batch, as per ASTM A370. .

S. NO	TEST	Material specification		
		SA/ASTM A216, 217	SA/ASTM A352	SA/ASTM A 351
1	Tension Test	As per the Specification		
2	Hardness Test	As per the Specification		225 BHN. max.
3	Bend Test Specimen 1" x 3/4"		Angle of Bend	Dia of Pin
		WCB	90°	2t
		WCC	90°	2t
		WC6	120°	3t
		WC9	90°	3t
	C12A	90°	2t	
		Not applicable		S3 of SA703
4	Charpy- U Impact for all QCNRV.CRHNRV BODIES FOR IBR.	As per IBR. at Room temperature. Acceptance: Avg /Single=36J/32J min.		Not applicable
5	Charpy- V Impact for CE Marking-Pressure Equipment Directive (PED) items as Specified in the Purchase Order.	At 20 Deg.C temperature. Acceptance: Avg /Single=40J/27J min.		As per Specification
6	Charpy- V Impact for API -6D items if design temperature below minus 29°C (- 29 °C)	Test Temperature=As per specification Acceptance: Avg/Single=34J/25J		As per Specification
7	Charpy- V Impact for LPBP BODIES	At 20 Deg.C temperature. Acceptance: Avg /Single=27J/21J min.		Not applicable
				Not applicable

Product : **STEEL CASTINGS.(VALVES)**Document No: **TDC:0:412**Rev No : **18**Effective Date: **25.01.2012**

Page- 2 of 7

6.0 FETTLING, DRESSING & CLEANING:

- Dressing of castings- Free from risers, in gates, notches, undercuts and deep marks etc.
- Fused wires, parting line fins, chills etc. shall be removed by grinding.
- Gas cutting if employed shall be done before Heat treatment.
- Preheat the material to 200 Deg. C. before gas cutting the Alloy steels.
- Castings shall be blast cleaned both inside and outside for the removal of fused sand, scales etc.
- Visual inspection of castings for surface quality as per MSS-SP-55 shall be carried out.

7.0 NON DESTRUCTIVE TESTING (NDT) AFTER HEAT TREATMENT:

The NDE requirements for the castings shall meet the following as shown in Table-1 below. Castings shall be free from surface and internal defects like porosity, shrinkage, sand inclusion, crack, cold shut and other harmful defects. All castings shall be of Radiographic Quality.

Radiographic Testing Procedure: As per ASME B16.34.

Magnetic Particle Inspection (MPI): As per ASTM E709

Liquid Penetrant Inspection (LPI): As per ASTM E165

Table: 1

Product	Components	Charecteristics	Type of NDE Check				
			RT	RT Area	RT Acc. Std	MT \$	MT Area
Conventional Valves (Gate, Globe & Check) and API 6D Gate Valves	Body, Bonnet Pr. part Yoke	< 600Class	10%#	ASME B16.34 (latest) / On critical area as indicated in the Drawing.	As per Table: 2	--	--
	Body, Bonnet, Cover	600Class & above	100%			--	--
	Body, Bonnet, Cover	1500Class & above	100%			100%	All accessible surfaces including belly
	Wedge	All Special Class Valves	--			--	--
Safety Valve	Base	All	10%#	Critical Zones as given in the Drawing/ area shown in the sketch in Page-5. The areas where RT cannot be carried out MPI shall be done.	Class-4 of ASTM E446/ E186. For Butt weld ends Table-2	100%	All accessible surfaces .
		Weld ends of All Castings	100%			--	--
Safety Relief Valve	Base & Bonnet	All	10%#			--	--
	SRV Nozzle	All	100%	All area	Class-2 of ASTM E446/ E186	--	--
QC NRV, CRH NRV	Body	150 & 300 Class	10%	Butt Weld Ends,	As per Table: 2	100%	All accessible surfaces including belly
		600Class & above	100%	Critical Zones as given in the Drawing/ area shown in the sketch in Page-6. The areas where RT cannot be carried out MPI shall be done.	As per Table: 2	100%	All accessible surfaces including belly
	Body (Special)	All					
Soot Blower Valve	Body	All	10%#	Critical Zones as given in the Drawing/ area shown in the sketch in Page-5. The areas where RT cannot be carried out MPI shall be done.	As per Table: 2	--	--
CRH Isolating Device	Body	< 600Class	100%	Critical Zones as given in the Drawing/ area shown in the sketch in Page-5. The areas where RT cannot be carried out MPI shall be done.	As per Table: 2	--	All accessible surfaces including belly
		600Class & above				--	
		1500Class & above				100%	
LP Bypass Valve	Body	All	100%	Critical Zones as given in the Drawing/ area shown in the sketch in Page-6. The areas where RT cannot be carried out MPI shall be done.	As per Table: 2	--	--

§ LPI Can be substituted for MPI in all inaccessible area and for stainless steel castings. # Refer CI 7.1

Product : **STEEL CASTINGS.(VALVES)**Document No: **TDC:0:412**Rev No : **18**Effective Date: **25.01.2012**

Page- 3 of 7

Table: 2

TYPE OF DISCONTINUITY	ACCEPTANCE LEVEL CATEGORY	< 600 CLASS		≥ 600 CLASS	
		Thickness ≤2"	Thickness >2"	Thickness ≤2"	Thickness >2"
Gas Porosity	A	A2	A3	A1	A2
Sand/Slag inclusion	B	B3	B3	B2	B2
Shrink Type-1	C	CA2	CA3	CA1	CA2
Shrink Type-2	C	CB3	CB3	CB2	CB2
Shrink Type-3	C	CC3	CC3	CC2	CC2
Crack	D	NONE	NONE	NONE	NONE
Hot Tear	E	NONE	NONE	NONE	NONE
Unfused Inserts (Chills/Chaplets)	F	NONE	NONE	NONE	NONE

a. Butt welding ends shall be free of shrinkage, crack & hot tear.
b. For butt weld ends Gas hole/Porosity and sand inclusions to be within level A1 & B1 respectively

7.1 # 10% Sampling shall be done as follows: (Wherever specified):

The vendor shall select 10% the Casting from the lot consisting of same size and type, (along with melt number and Sl.nos of the castings covered in the lot) for Radiography. A lot to be specified as the total number of castings as above, supplied in 4 months period (Jan-Apr, May-Aug, Sep-Dec). The vendor shall radiograph these specified castings and incorporate the lot size and melt no and Sl.no in the RT reports along with the other sl.nos of the other castings covered in the lot. If the identified casting is defective then 2 more castings shall be radiographed.If these 2 castings are defect free then the lot is acceptable.If any one of these castings is defective then all the remaining castings shall be radiographed and all defective areas shall be repaired. BHEL will carry out audit on the lots at the vendor works at any time.

7.2 **Acceptance for MPI & LPI:** ASME B16.34.

(1)Cracks are not permitted.

(2)For linear indications (with length > 3 times width) other than cracks,indications must be separated by a distance greater than the length of an acceptable indication. Maximum allowable length of the indication shall be:

- (a) For thickness (t) up to 13mm= 8mm,
(b) For thickness from 13 to 25mm = 13mm
(c) For thickness above 25mm =18mm.

(3)For rounded indications (circular or elliptical with length < 3 times width), 4 or more indications in a line separated by 1.5 mm or less edge to edge are unacceptable. Maximum allowable diameter of the indication shall be:

- (a)For thickness up to 13mm =8mm, and (b)For thickness above 13mm =13mm

8.0 **Development Stage of Casting:**

- a. During developmental stage, Foundry to ensure, first sample pieces meet dimensional, NDE & Quality requirements in this TDC, before starting bulk production. Sample castings, 3 Castings with nominal bore (NB) ≤100mm. & 1 casting with NB > 100mm for each type of casting shall be inspected for dimension and RT requirements at BHEL/Vendor works. RT shall be carried out on entire area of the casting to the acceptance requirement of Table-1 & 2. In addition 100% MPI on all critical areas like change of sections, riser & in gate portions shall be carried out. Casting to be inspected for dimensions after proof machining wherever necessary. If machining operation is involved the same shall be done and defect free condition shall be ensured. If any defect noticed in RT and machining, the type of defect shall be analysed and accordingly size of gate, runner, riser and pouring methodology to be modified to get defect free casting. Sampling shall be continued till achieving sound casting. After satisfactory development of sampling bulk production shall be started. However weld repaired areas identified in visual examination for doubtful indications to be probed by MPI. Accepted sample castings may be considered for fixing the nominal weight of the castings.
- b. During developmental stage RT on sample castings of yoke, yoke clamp & wedge/disc shall meet Level-3 of ASTM E446/E186/E280
- c. Radiography not required after satisfactory development of casting & production based on established method for following parts: SRV Bonnet,Disc holder,Upper and Lower adjusting rings, Packed cap,Cover plate,Yoke and SRV guide flanges

Product : **STEEL CASTINGS.(VALVES)**Document No: **TDC:0:412**Rev No : **18**Effective Date: **25.01.2012**

Page- 4 of 7

9.0 REPAIR:

Castings with unacceptable cracks, hot tears, shrinkage, etc. to be rectified by grinding & if required by welding. Welding to be done by qualified welder and qualified procedure as per ASME Section IX .For IBR items welder shall be qualified as per IBR.

Guidelines for repair of Steel castings shall be as per SIP:VS:17 (latest).for activities like defects require/ not require weld repair, welding, Post weld heat treatment, NDE and surface treatment. All repaired areas after PWHT shall NDE tested and Hardness tested. Hardness shall meet material Specification.

For CE-Marking (PED) casting, permanent joining (welding and weld repair) of components must be carried out by suitably qualified personnel according to suitable operating procedures. Also Non-destructive tests of permanent joints must be carried out by suitable qualified personnel. The procedures and personnel must be approved by a competent third party which, at the manufacturer's discretion, may be:

- a notified body,
- a third-party organization recognized by a Member State of European Community

10.0 SURFACE TREATMENT:

SS castings to be pickled & passivated (after repair & HT if any) as per ASTM A380. Satisfactory passivity of the surface to be checked using SS passivity test kit (Free iron test). After passivation, rinsing & test, the rinsed demineralised water to be checked for chloride with 1% Silver nitride, which shall not exceed 0.5 PPM

11.0 DIMENSIONAL CHECK:

For all QCNRV & CRHNRV Body Castings: Thickness of the body shall be checked throughout the surface on a grid of 100mm x 100mm and recorded & submitted to BHEL.

12.0 MARKING AND PACKING:

Following details to be marked on each casting on a raised pad using low stress stamps and Castings shall be suitably packed to avoid damage during transit.

1. Foundry code, 2.Specification, grade & Melt number, 3.Other details as per drawing.

13.0 INSPECTION AND CERTIFICATION:**13.1:** For IBR items

a) If the Foundry is recognized as "Well known Foundry" under IBR, Items shall be inspected by foundry and works certificate along with IBR *Form III F* shall be issued.

b) If the Foundry is not recognized as "Well known Foundry" under IBR, Items shall be inspected by an Inspecting Authority approved by IBR and work certificate along with IBR *Form III G* shall be issued.

13.2: For CE-marking items, the materails shall be inspected by M/s. LLoyd's/ TUV/ BVQI or anyother ageny approved for PED of CEmarking, if the foundry is not certified to ISO 9000 by any of the . above organisation.**13.3** For API items, the castings shall be inspected by the foundry and works certificate with details like PSL No., Temperature class rating, size shall be issued.**13.4** Test certificates shall contain the following details.

- 1.Purchase Order No.(BHEL),TDC No. & Test certificate number
2. Specification and Grade with applicable year of code, Heat Number, Quantity & Size
3. Steel making process, Chemistry including incidental elements - Heat wise.
4. Heat treatment details of the material and test bars.
5. Mechanical test results, NDE test results with reference & acceptance standard.
6. Repair details including HT, if any, Cleaning & Surface treatment details.
7. Any other information like clearance of sample casting.
8. Dimensional Inspection Report where applicable.

14.0 AUDIT CHECKS AT BHEL:

BHEL reserves the right to carry out audit checks for chemistry, HT condition, mechanical test and NDT on representative test bars or job. Items found defective during check or subsequent processing at BHEL are liable for rejection.

15.0 END USE:

For use in valves and other components like flanges, fittings etc. for high temperature & high pressure applications meeting IBR, ASME Section I, ASME B 16.34, PED and API.

Sketch of zones for RT

SV and SRV Base castings

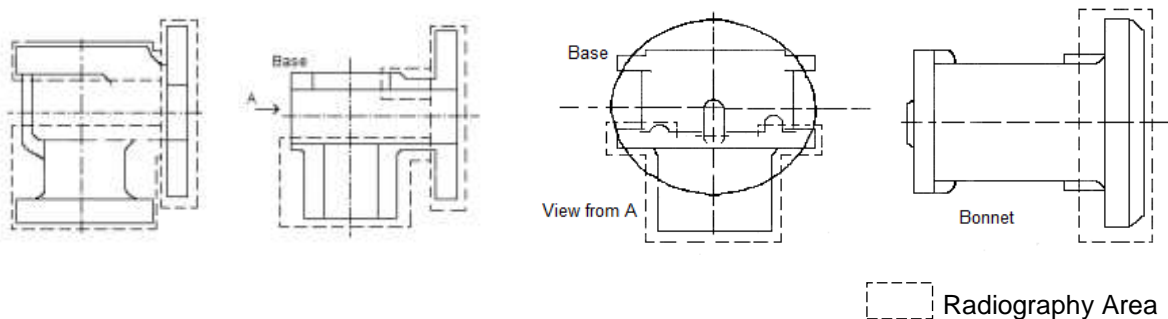

Reheater Isolating Device Body

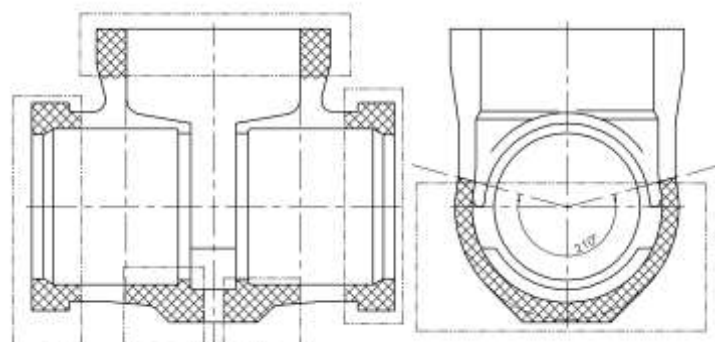

 Radiography Area

Product : **STEEL CASTINGS.(VALVES)**

Soot Blower Valve Body

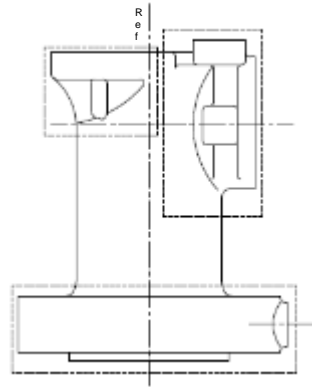

 Radiography Area

Quick Closing Non Return Valve Body

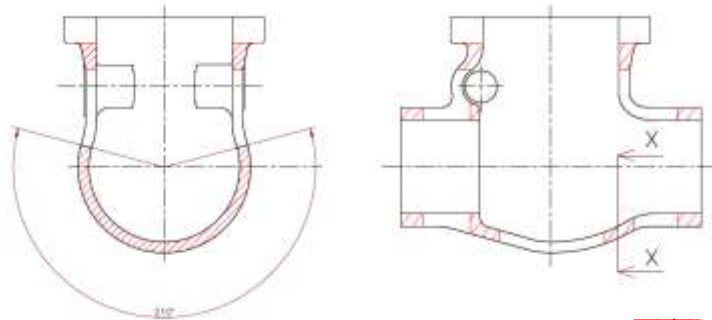

Section-XX

 Radiography Area

Cold Re Heat Non Return Valve Body

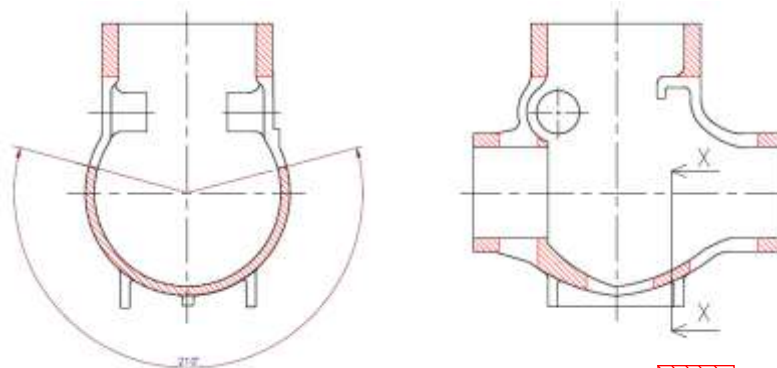

Section-XX

 Radiography Area

Product : **STEEL CASTINGS.(VALVES)**

Document No: **TDC:0:412**

Rev No : **18**

Effective Date: **25.01.2012**

Page- 7 of 7

LP Bypass Stop cum Control Valve Body

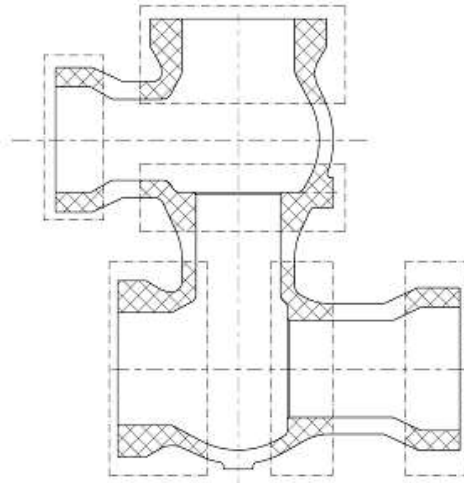

 Radiography Area

			
D.SUDHAKARAN QUALITY ASSURANCE	M.RAJAKUMAR ENGG/VALVES	S.SELVARAJAN QUALITY ASSUARANCE	V.RAVIKUMAR QUALITY ASSURANCE
PREPARED BY	REVIEWED BY		APPROVED BY



BHEL GOINDWAL

TERMS AND CONDITIONS FOR
(Tender Enquiry No. 1213-039 dt. 12.06.2012)

PRE-QUALIFICATION TERMS

P1 Quotations are invited for supply of **Non IBR Steel Castings** as per Tender document. The tenderer should be a foundry engaged in a manufacture of various grades of Steel.

The prequalification criterion is defined as below.

1. Should have sufficient in-house Foundry Facility (supported by list of facilities). Please **attach the list of complete foundry facilities**. The vendor should attach at least one **copy of purchase order** of steel castings (For year 2011-12). The cumulative POs should have minimum value of 10 Lacs.
2. Annual turnover of the foundry should exceed Rs. 150 Lacs. For verification of data, latest (not before financial year 2010-11) audited balance sheet (as applicable) should be attached.
3. Foundry should have minimum spare capacity – 05 MT/Month. **Please give an undertaking mentioning that minimum 05 MT/month can be supplied after development of patterns as per the load given by BHEL.**

P2 (i) Bidders not registered with any unit of BHEL are required to deposit an **amount of Rs. 1,00,000/- as Earnest Money (EMD)** by way of DD in favour of BHARAT HEAVY ELECTRICALS LIMITED, INDUSTRIAL VALVES PLANT, GOINDWAL SAHIB Payable at Punjab National Bank, Goindwal Sahib only. Central/State PSUs/State owned Corporations/MSE (Micro & Small Enterprise) units are exempted from EMD, for which relevant documentary proof has to be submitted in the envelope of EMD. The units registered with BHEL have to give their vendor code. MSE units have to submit their MSME certificate. Central/State PSUs/State owned corporations have to give their website as proof.

- (ii) EMD shall be forfeited if after opening the tender, the bidder revokes his bid within the validity period or increases his earlier quoted prices.
- (iii) EMD shall be forfeited if the bidder does not commence the work within the period as per LOI/PO.
- (iv) EMD submitted by all unsuccessful bidders shall be refunded normally within 20 days of finalization of Rate Contract with interested bidders.
- (v) EMD shall not carry any interest.
- (vi) EMD amount (without any interest) shall be adjusted against security deposit SD/returned after receipt of security deposit (SD) for successful bidder.

P3 The vendors who are registered with BHEL, Goindwal and already bound by some commitment in previous tenders of which supplies are being made concurrently, have to ensure that commitment against this tender is addition to such earlier commitments. Also any vendor who has taken Purchase order for IBR Items from IVP Goindwal are not eligible to quote.

BHEL reserves the right to accept/reject any offer based on evaluation of bidder's capability/bidder's performance in earlier/ongoing contracts. BHEL reserves the right to decrease/cancel any item's tender quantity as per requirement. For verification of data

Rosh Kumar



BHEL GOINDWAL

TERMS AND CONDITIONS FOR
(Tender Enquiry No. 1213-039 dt. 12.06.2012)

presented for pre-qualification bid, BHEL may decide to visit the bidder(s) works. Any fact found deviating from bids during evaluation shall make the bidder liable to be dis-qualified.

P4 **IF THE OFFER IS NOT ACCOMPANIED WITH ACCEPTANCE OF TERMS AND CONDITIONS, IT SHALL BE CONCLUDED THAT ALL THE TERMS AND CONDITIONS ARE ACCEPTABLE AND NO CLAIM WHATSOEVER SHALL BE ENTERTAINED LATERON.**

Ash Kumar



**TERMS AND CONDITIONS FOR
(Tender Enquiry No. 1213-039 dt. 12.06.2012)**

TECHNO-COMMERCIAL TERMS [UNPRICED BIDS]

1. INVITING TENDERS:

Three-part sealed quotations are invited for radiographic quality castings (Non IBR) of valve components of different material grades as per relevant TDC/Matl Stands/Drgs/QP as per enquiry list at following terms and conditions. Submission of three parts shall be as follows:

Bid	Bid description	Superscribing on envelope	*** Should contain ***
Part-I in First sealed envelope	EMD	Part-I EMD against tender enquiry No. 1213-039 Dt. 12.06.2012	<ol style="list-style-type: none"> The tenderer shall be required to deposit earnest money of Rs. 1,00,000/- (Rupees One Lac only) through Demand Draft/Pay Order payable at Punjab National Bank at Goindwal Sahib, Distt. Tarn Taran. If vendor is exempted from EMD, then he should write the reasons under which EMD exemption is being asked.
Part II in Second sealed envelope	Techno-Commercial Offer	Part-II (Techno-Commercial) bid against tender enquiry no: 1213-039 Dt. 12.06.2012	<ol style="list-style-type: none"> Documents required against Prequalifying Criteria. Acceptance of all terms and conditions of tender enquiry. (Preferred is submitting signed copy of terms and conditions; if nothing is mentioned for any term, it shall be summarily concluded that the same is acceptable and no representation whatsoever shall be entertained later on). Un-priced bid as per format attached. All details, i.e. whether quoted for item, duties and taxes etc. should be filled.
Part III in third sealed envelope	Price Bid	Part-III (Price) bid against tender enquiry No. 1213-039 Dt. 12.06.2012	<p>Price bid in the format attached. The price bid envelop should contain ONLY the price bid. Further, even if the same conditions are mentioned in the Part-III, but after scrutiny of Part-I&II, the bidder has agreed to BHEL terms, the same shall be binding and any such condition found in Part-III shall in no case be discussed.</p> <p>Anything other than price mentioned in the price bid shall be considered invalid</p>

All three sealed envelopes should be put in outer sealed envelope super scribing all details.

Quotations shall reach by 1500 Hrs and Part-I&II shall be opened at 1530 Hrs on due date **09.07.2012**. Late offers are liable to be rejected, so please ensure to send the quotation well within due date.

Based on evaluation of techno-commercial offers, BHEL may conduct RA for finalization of tender. If RA is not conducted then price bids of bidders who qualify from techno-commercial evaluation shall be opened.

Rosh Kumar



BHEL GOINDWAL

TERMS AND CONDITIONS FOR
(Tender Enquiry No. 1213-039 dt. 12.06.2012)

2. **PRICE QUOTATION**

The quoted rates should be in INR per piece basis. The establish weight of each item is given just for reference. The quoted price should be per piece basis irrespective of weight.

- 2a. CST, VAT & Excise duty + any cess on ED at the rates applicable shall be payable extra against ED Gate Pass valid for CENVAT benefit.
- 2b. Rates shall be on **FOR Goindwal basis**.
- 2c. Unloading of material at Main Stores of BHEL shall be arranged by BHEL.
- 2d. **Order of enquiry item sl. No. shall be maintained in the quotation.**
- 2e. **The rates quoted shall be firm and fixed. No price variation is proposed and allowed.**

Quoted prices should be mentioned both in numbers and words. If price quoted in numbers differs from as mentioned in words, then rates quoted in words will be taken as final rates. Also party has to quote firm rates without mention of discounts.

3. **VALIDITY OF OFFERS:**

The offers shall valid for 90 days from the date of opening of the techno-commercial (Part-II) of the tender. In case of extension of tender opening date, the validity shall be deemed to be suitably revised.

4. **SCOPE OF SUPPLY:**

Material shall be supplied as per the applicable latest Technical Delivery Conditions (TDC)/ Material Standard requirements/Drawings/Quality Plan/RT Procedure and other requirement as given in the Purchase Order. The vendor has to supply castings as per BHEL drawings.

5. **DELIVERY SCHEDULE:**

Supplies shall be affected and completed as per schedule mentioned in the POs. **Delivery required is within six months progressively.** The supplier should get requisite no. of samples approved from BHEL maximum **within three months**, after which BHEL reserves the right to cancel the PO with no obligation for the investment on part of supplier and by imposing the appropriate risk purchase clause if BHEL's commitment to customer is affected. Further, BHEL may release delivery schedule from time to time based upon our requirement. Vendor shall be required to complete the order as per the PO/schedule requested.

Vendor will mention the supplies commitment per month in MT as per Annexure-A. Further the time required to develop the sample is also to be mentioned in the said annexure. BHEL will decide the loading and delivery schedule from a vendor depending on analysis of final situation emerging out of monthly commitments/patterns availability/sample approval time commitment.

Rosh Kumar



BHEL GOINDWAL

TERMS AND CONDITIONS FOR
(Tender Enquiry No. 1213-039 dt. 12.06.2012)

6. REPLACEMENT OF REJECTION:

If the material is rejected due to defective workmanship during inspection or at the time of actual use, the rejected material shall be replaced by the supplier. Corresponding quantity shall be treated as unsupplied against respective purchase order till replacement is received at BHEL. If the material is found defective and rejected during use for which payment has already been released the rejected quantity shall be supplied free of cost by the vendor within a month of intimation of the rejection by BHEL.

7. ACCESS TO MANUFACTURING PREMISES:

While Purchase Orders placed on the vendor are under execution, authorized representatives of BHEL shall be allowed free access to the manufacturing facilities/sub-vendors' premises for the purpose of inspection or monitoring the progress of purchase orders. This access will also be extended to representatives of BHEL's customers accompanying the authorized representative/s of BHEL (which shall be intimated in advance), if our contractual requirements with our customers call for the same.

8. TERMS OF PAYMENT:

- a. 100% payment against supplies received shall be made **within 30 –45 days** of receipt & acceptance of material at IVP Goindwal and receipt of following dispatch documents. In case of any deviation from standard payment term mentioned, BHEL at it's discretion may load on the item price at prime lending rate of SBI + 2% for the period of relaxation sought by bidder.
 - i. Commercial invoice (in duplicate)
 - ii. Excise invoice (in duplicate) valid for claiming CENVAT credit
 - iii. Original VAT invoice valid for claiming input tax credit, if applicable
 - iv. Material Test Certificates (MTC) and
 - v. Compliance Certificate.
 - vi. Radiographic films and reports, if required.
- b. Above documents should include your Registration numbers such as ECC no, PAN no, CST no, TIN/ VAT nos. etc.
- c. **It is mandatory to mention proper material codes in the invoices and separate invoices to be raised for different POs/radio graphed components.**
- d. ***BHEL releases payment through EFT mode ONLY. Vendors, on whom, finally POs are released will have to provide the necessary details by obtaining format before release of payment while supplying the material, if already not submitted.***

9. INSPECTION:

Casting shall meet all requirement (Physical properties, Chemical properties, Heat Treatment, NDE, Visual, Surface finish etc.) of relevant standards mentioned in TDC/MatI Standards/Drgs as applicable. The inspection of machined castings will be done as per quality Plan attached.

Rosh Kumar



BHEL GOINDWAL

TERMS AND CONDITIONS FOR
(Tender Enquiry No. 1213-039 dt. 12.06.2012)

Integral test bars, as required, shall be made avl free of cost. All testing charges shall be inclusive and no extra charges shall be paid except for RT. Inspection of development casting shall be carried out by BHEL. Inspection of bulk supply shall be carried out by BHEL/TPI at suppliers' works. Inspection shall be arranged by BHEL but necessary facilities & testing shall be provided/ carried out by supplier. Required test certificates shall be submitted in prescribed format along with packing note & compliance certificate.

Castings shall also be subjected to impact tests as called for in TDC and the testing charges shall be borne by the vendor.

Sample castings are to be identified by vendor in the delivery challan as "Sample" and the dimensional reports and RT reports are to be provided to BHEL along with supply.

Vendor will give inspection call sufficiently in advance considering the delivery period stipulated in the purchase order.

10. RADIOGRAPHY:

Consistent radiography quality is to be ensured and to be maintained uniformly in bulk supply with adequate process and method controls. Since the castings required are of radiographic quality, BHEL reserves the right to conduct radiographic testing of sample pieces at its own arrangement and derive conclusion of soundness of casting supplied against the said lot/heat based on the results of such testing.

Radiography procedure shall be as per BHEL's TDC/BHE: NDT: VV: RT: 06 Rev 07 and specific instructions from BHEL. All the radiography films shall be dispatched to BHEL without delay either before the castings are being dispatched or along with the castings. Vendor shall undertake radiography on new development as per TDC 412 Rev.18.

- BHEL intends to get delivery of castings along with radio graphed sets as ordered. The claim of vendor for payment of supplies against any PO can be put on hold if the requisite no. of radiographed sets has not been delivered by then. BHEL shall reserve the right to select any sample from a lot offered and get it radiographed at vendor's works. The supplier should ensure that the castings supplied should be in sets only. BHEL reserves the right of hold payment of supplier if castings not supplied in sets.

As per requirement of BHEL, vendor will be required to submit radiographic test reports as specified in the purchase orders released under the purview of the contract. BHEL will review and evaluate radiography films and RT reports and reserves the discretion to do so at the premises of the vendor.

Fixed RT charges @ Ir₁₉₂ : ` 0.99 & Co₆₀ : ` 1.50 per sq. cm (In case CST is not applicable) shall be paid on actual verified film area and it is @ Ir₁₉₂ : ` 0.97 & Co₆₀ : ` 1.47 per sq. cm in case of CST applicable.

Prashant Kumar



BHEL GOINDWAL

TERMS AND CONDITIONS FOR
(Tender Enquiry No. 1213-039 dt. 12.06.2012)

11. REPAIR OF CASTINGS:

- a. All castings shall be supplied free of defects like shrinkage, hot tears and process variable defects like sand inclusion, slag inclusion, gas entrapment etc. If any casting is found defective, the same shall be upgraded at foundry itself before dispatch to BHEL with necessary documentation, enabling BHEL to make use of such castings immediately for production.
- b. Castings, during radiography and other NDT tests, either at BHEL or at our sub-contractor's works at different stages of manufacturing are found to be defective shall be repaired at the defective area and the repaired area shall be re-radio graphed & LPT etc. at vendors cost for further acceptance. BHEL shall decide about the areas to be repaired in all such cases.
- c. Repair of castings that are found defective after receipt/acceptance at BHEL will be carried out by BHEL and repair charges @ Rs. 13.00 per cc for WCB and @ Rs. 16.00 per cc for other grades shall be deducted from any of the running bills of the vendor. Rework/repair of castings on account of any other process deficiency-if carried out by BHEL shall attract deduction at above rates [equivalent units derived mutually].

In case of rejection of casting after assembly/testing etc. then the entire cost incurred shall be deducted from any of the running bills of the vendor.

12. LIFTING REJECTED CASTINGS:

- a. The castings that are not acceptable during receipt inspection at BHEL shall be intimated through Rejection Memo or similar communication from BHEL. Similarly, castings that are found defective during assembly/ hydraulic testing shall be repaired or rejected depending upon severity of defects. Rejected castings, shall have to be lifted within 45 days of informing, beyond which, BHEL will not be responsible for any loss/demurrage. BHEL reserves the discretion to levy storage charges for material not lifted within the reasonable period.
- b. Necessary deductions on account of such rejections shall be made from vendor's bills.

13. LOADING:

BHEL reserves the right to negotiate with L1 or re-float the tender in case the quoted prices are not acceptable. BHEL will give counter-offer to vendors other than L1 except highest bidder, in order to have broader vendors base for ensuring timely delivery. Following directions shall be followed when allotting the tender quantities:

1. Tender quantity shall be divided in the proportion 60:20:20 (60% for L1, 20% for L2 and 20% for MSE's) in case the L1 vendor is not a MSE subject to following conditions:
 - I. L2 acceptance of L1 rates.
 - II. In tender, participating Micro and Small Enterprises quoting price within price band of L1+15 per cent shall also be offered 20% quantity of tender quantity at L1 price in a situation where L1 price is from someone other than a Micro and Small Enterprise. In case of more than one such Micro and Small Enterprise, the supply shall be shared equally. If there are more

Rosh Kumar



BHEL GOINDWAL

TERMS AND CONDITIONS FOR
(Tender Enquiry No. 1213-039 dt. 12.06.2012)

than one MSE in the price band of L1+ 15% to whom the offer has been sent and some of them reject the offer then the remaining quantity shall be distributed equally to the MSEs accepting L1 prices.

III. 20% from the 20% quantity (i.e. 4% of the tender quantity) offered to the MSE's shall be reserved for MSE's owned by SC/STs. In event of failure of such Micro and Small Enterprises to participate in tender process or meet tender requirements and L1 price, 4 per cent quantity for Micro and Small Enterprises owned by SC/ST entrepreneurs shall be met from other Micro and Small Enterprises.

IV. In case any MSE vendor does not accept the counter offer, the above mentioned 20% quantity shall be offered to L2 subject to its acceptance to L1 price.

V. If there is no MSE in the Price band of L1+15% then the 20% quantity shall be offered to L2 vendor subject to his acceptance of L1 rates.

2. In case if the L1 vendor is MSE then quantity shall be provided as 56 % and 40% in L1 and L2 vendor respectively subject to acceptance to above mentioned provision no.(I). 4% tender quantity shall be offered to the MSEs owned by SC/ST's in the price band of L1+15%. In event of failure of such Micro and Small Enterprises to participate in tender process or meet tender requirements and L1 price, 4 per cent sub-target for procurement earmarked for Micro and Small Enterprises owned by SC/ST entrepreneurs shall be met from L1 vendor.

3. In case the L1 vendor is a MSE owned by a SC/ST then the quantity shall be divided as 60% and 40% to L 1 and L2 vendor respectively subject to acceptance of L1 rates by L2 vendor.

In case of non-acceptance of counter offer by L2 vendor, the counter offer will be given to L3 vendor and all above provisions in which L2 vendor is mentioned will be studied by taking L3 vendor and the same will be continued except the highest bidder.

In case of non- acceptance of counter offer by any vendor after above applicable provisions the whole quantity would be offered to L1 vendor.

This ratio can be altered in case of any failure on part of L1 regarding delivery commitment/quality of material. In case of non-acceptance of counter offer by L2 vendor, L3 will be contacted and so on except highest bidder. All above mentioned preferences shall be given to MSEs and SC/STs only on the submission of documentary evidence.

BHEL will place orders in any proportion based on pattern availability, sample development time, BHEL delivery requirement and vendor's monthly commitment if their commitment does not meet above division criteria. Performance of vendors shall be monitored as per the performance monitoring system attached. **L1 vendor shall be assured of sufficient load according to his capacity and fulfilling of other requirements as per Annexure-A.**

14. **GUARANTEE:**

Vendor shall give a guarantee of 18 months from the date of dispatch or 12 months from the date of put to use whichever is earlier against any manufacturing defects.

Bhaskar Kumar



BHEL GOINDWAL

TERMS AND CONDITIONS FOR
(Tender Enquiry No. 1213-039 dt. 12.06.2012)

15. **RISK PURCHASE:**

BHEL shall be entitled to terminate the contract/pending POs and to purchase elsewhere at the risk and cost of the vendor, either the whole of the goods or any part thereof which the supplier has failed to deliver or dispatch within the time stipulated as aforesaid. Vendor shall be liable for the losses, which BHEL may sustain by way of such risk purchase in addition to aforesaid penalty for delayed delivery.

16. **SUB-CONTRACT:**

The arrangement of sub-contracting [machining or foundry] shall not be altered without previously obtaining the BHEL's consent in writing. BHEL reserve the right to evaluate the proposed sub-vendor as per criteria mentioned pre-qualifying terms.

17. **FORCE MAJEURE:**

If at any time during the continuance of the contract, the performance in which or in any part by either party of any obligations under the contract are prevented or delayed by reason of any war, hostilities, acts of public enemy, civil commotion, sabotage, fires, explosions, epidemics, quarantine restrictions, or acts of God (hereinafter referred to "an events" then provided the notice of happening of any such event is given by either party to the other within 21 days of the occurrence thereof, neither party shall by reason of such event be entitled to terminate the contract nor shall either party have any claim for damages against the other in respect of such non-performance and delay in performance and delivery under the contract shall be resumed as soon as practicable after such event has come to an end or ceased to exist. If the performance in whole or part of any obligation under the contract is prevented or delayed by reason of any such event, claims of extension of time shall be granted for periods considered reasonable by BHEL subject to prior notification by the vendor to BHEL of the particulars of the event and supply to BHEL, if required, of any supporting evidence. Any waiver of time in respect of partial installment shall not be deemed a waiver of time in respect of remaining deliveries.

18. **DISPUTES:**

In the event of any dispute and/or difference arising between the Vendor and BHEL as to interpretation and/or execution of the contract and/or the respective rights and liabilities of the parties, such disputes and/or differences shall be referred to the sole arbitrator nominated by BHEL. The provisions of the Indian Arbitration Act and the rules there under shall apply to such arbitration. The award passed by the arbitrator shall be final and conclusively binding on all the parties.

19. **JURISDICTION:**

The court of the place from where the purchase order is issued during the contractual period shall alone have jurisdiction to decide any dispute arising out of or in connection with the purchase order.

Bush Kumar



BHEL GOINDWAL

TERMS AND CONDITIONS FOR
(Tender Enquiry No. 1213-039 dt. 12.06.2012)

20. MSME Certification:

If the bidder is registered as any of Micro/Small/Medium enterprise as defined in Micro Small and Medium Enterprises Development Act, 2006; a copy of registration certificate to be attached.

21. MSE Clause

MSE's shall be given preferences as described in "Public Procurement Policy for Micro and Small Enterprises (MSEs) Order, 2012" subject to the submission of proper documentary evidence (i.e. District Industries Centers or Khadi and Village Industries Commission or Khadi and Village Industries Board or Coir Board or National Small Industries Corporation or Directorate of Handicrafts and Handloom or any other body specified by Ministry of Micro, Small and Medium Enterprises) with quotation. "Public Procurement Policy for Micro and Small Enterprises (MSEs) Order, 2012" document can be downloaded from link <http://dcmsme.gov.in/FinalPressorder.pdf> and can also be collected from the office of Manager/MM IVP Goindwal

22. Penalty for delay in delivery of material:

'Time is the essence of the contract'. As such, delivery of goods specified in the Purchase Orders released under the scope of this contract shall be made within the time limit prescribed therein. Penalty clause will be applicable for delayed supplies @ 0.5% per week or part thereof subject to a maximum of 5.0 %.

23. DEALING WITH BANNED SUPPLIERS /CONTRACTORS:

The Offers of the bidders who are on the banned list as also the offer of the bidders, who engage the services of the banned firms, shall be rejected. The list of banned firms is available on BHEL website www.bhel.com

24. GENERAL:

- a) BHEL will not be bound by any power of attorney granted by the vendors or by changes in the composition of the firm made subsequent to the execution of the contract. They may, however, recognize such power of attorney and changes after obtaining proper legal advice, the cost of which will be chargeable to the vendor concerned.
- b) BHEL reserves the right to extend the due date of opening, which shall be informed. Validity of offer shall be deemed to be revised accordingly.
- c) BHEL reserves the right to accept or reject any part or whole of the tender by assigning a valid reason thereof. BHEL reserves the right to cancel the tender without assigning any reason thereof and without any obligation before any commitment.

Rush Kumar



BHEL GOINDWAL

TERMS AND CONDITIONS FOR
(Tender Enquiry No. 1213-039 dt. 12.06.2012)

- d) Please submit acceptance of all techno-commercial terms along with quotation. If nothing is mentioned for any term, it shall be concluded that the same is acceptable.
- e) The drawing given with tender are sole property of BHEL, these drawings are not to be reproduced for any purpose.

25. Supplier Registration:

Bidders, who are not currently on registered list of BHEL IVP Goindwal Sahib, may submit duly filled format for "Vendor Registration form". The form can be downloaded from our website www.bhel.com or can be requested at gss@bhelivp.in or rajeshk@bhelivp.in. Registered vendors with BHEL IVP GWL have to mention their vendor code. Registered vendors with any other unit of BHEL are also required to mention the vendor code given by respective BHEL unit along with photocopy of latest POs from BHEL unit. Techno-commercially qualified bidders may be asked for submission of supplier registration form for getting registered with BHEL, IVP, Goindwal.

26. Security Deposit:

Security Deposit @ 1% of basic value from each invoice will be deducted. Interest free Security Deposit (full or partial after deduction of any amount chargeable from vendor) shall be refunded after completion of order(s) against this tender. EMD amount (without any interest) shall be adjusted against security deposit/returned after receipt of security deposit for successful bidders.

27. LOI(Letter of Intent)

BHEL may issue LOI prior to the PO for any reason whatsoever. The LOI in such cases is to be treated as PO for all practical purposes and all the Terms & Conditions of the tender shall be applicable from the date of issue of LOI.

28. REVERSE AUCTION:

BHEL reserves the option to either finalize the tender by opening sealed price bids (Part-II) submitted with the offer on a specified date and time in the presence of bidders, who may like to be present; or carrying out live reverse auction on-line. In case of reverse auction, adequate infrastructure like internet connection, uninterrupted power supply, printer, fax machine etc. will have to be arranged by bidder. BHEL will engage a service provider who shall interact, educate, guide and coordinate with bidder for reserve auction. Date and time of reverse auction shall be informed.

Information and general terms and conditions governing RA are following.

GENERAL TERMS AND CONDITIONS OF RA

Against this enquiry for the subject item with detailed scope of supply as per enquiry specifications, BHEL may resort to "REVERSE AUCTION PROCEDURE" i.e., ON LINE BIDDING ON INTERNET.

Rajesh Kumar



BHEL GOINDWAL

TERMS AND CONDITIONS FOR
(Tender Enquiry No. 1213-039 dt. 12.06.2012)

1. For the proposed reverse auction, technically and commercially acceptable bidders only shall be eligible to participate.
2. BHEL will engage the services of a service provider who will provide all necessary training and assistance before commencement of on line bidding on internet.
3. BHEL will inform the vendor in writing in case of reverse auction, the details of Service Provider to enable them to contact & get trained.
4. Business rules like event date, time, Start price, bid decrement, extensions etc. also will be communicated through service provider for compliance.
5. Vendors have to fax the Compliance form in the prescribed format (provided by Service provider) before start of Reverse auction. Without this, the vendor will not be eligible to participate in the event.
6. BHEL will provide the calculation sheet (e.g., EXCEL sheet) which will help to arrive at "Total Cost to BHEL" like Packing & forwarding charges, Taxes and Duties, Freight charges, Insurance, Service Tax for Services and loading factors (for non-compliance to BHEL standard Commercial terms & conditions) for each of the vendor to enable them to fill-in the price and keep it ready for keying in during the Auction.
7. Reverse auction will be conducted on scheduled date & time.
8. At the end of Reverse Auction event, the lowest bidder value will be known on the network.
9. The lowest bidder has to Fax the duly signed Filled-in prescribed format as provided on case-to-case basis to BHEL through Service provider within 24 hours of Auction without fail.
10. Any variation between the on-line bid value and the signed document will be considered as sabotaging the tender process and will invite disqualification of vendor to conduct business with BHEL as per prevailing procedure.
11. In case BHEL decides not to go for Reverse Auction procedure for this tender enquiry, the Price bids and price impacts, if any, already submitted and available with BHEL shall be opened as per BHEL's standard practice.
12. BHEL reserves the right to negotiate if need be, with the "L1" vendor of the Reverse Auction.

Authorized Signatory
BHEL, IVP, Goindwal



70-006

Bharat Heavy Electricals Limited

High Pressure Boiler Plant, Tiruchirappalli-620 014, India.

Grams : BHARATELEC

Phone : --

Telex : 0455 - 211, 212, 295 & 298

FAX : 81 - (0431) - 52710

PRODUCT ENGINEERING/VALVES

VL:STDC:023

REV.00

PAGE 1 OF 6

TDC FOR UNTOLERANCED DIMENSIONS IN CASTING & FORGING DRAWINGS

Scope :

This technical delivery condition specifies the tolerance for the untoleranced dimension for the castings and forgings wherever tolerances are not specified in the applicable drawing applicable material TDC.

A. Castings :

Nominal dimension (in mm)		Tolerance on diameter & height (in mm)
UPTO	4	± 0.5
OVER	4 UPTO 16	± 1.0
OVER	16 UPTO 65	± 1.5
OVER	65 UPTO 125	± 2.0
OVER	125 UPTO 250	± 2.5
OVER	250 UPTO 500	± 3.0
OVER	500 UPTO 1000	± 4.0
OVER	1000 UPTO 1600	± 5.0

B. Forgings : As per Table (1), (2), (3) & (4)

PREPAREDCHECKEDAPPROVED

(S. KUMAR)
SM/PE/VSB
28/2/94

TABLE 1. LENGTH, WIDTH, HEIGHT, MISMATCH, RESIDUAL FLASH AND TRIMMED FLAT OF DROP, PRESS AND UPSET FORGINGS (NORMAL TOLERANCES)

DROP, PRESS & UPSET FORGINGS - TOLERANCES FOR: LENGTH, WIDTH & HEIGHT ^M																			
MISMATCH	RESIDUAL FLASH (+) TRIMMED FLAT (-)	TRIM LINE		WEIGHT (kg)	DIFFICULTY OF MATERIAL	COMPLEXITY	MISMATCH ; RESIDUAL FLASH & TRIMMED FLAT ^(DIA & LENGTH FOR UPSET FORGINGS)												
		ASYMMETRIC	STRAIGHT OR SYMMETRIC				NOTE: CENTRE TO SURFACE; STEP IN ONE DIE; + $\frac{1}{3}$, - $\frac{1}{3}$ OF TOTAL TOLERANCE												
							INTERNAL DIMENSION: REVERSE + AND - SIGNS.												
							MM												
							TO	INCL											
							ABOVE	32	100	160	250	400	630	1000	1600	2500			
0.4	0.5	/	/	0-0.4	/	/	1.1 ^{+0.7} _{-0.4}	1.2 ^{+0.8} _{-0.4}	1.4 ^{+0.9} _{-0.6}	1.6 ^{+1.1} _{-0.8}	1.8 ^{+1.2} _{-0.8}	2 ^{+1.3} _{-0.7}							
0.5	0.6	/	/	0.4-10	/	/	1.2 ^{+0.8} _{-0.4}	1.4 ^{+0.9} _{-0.6}	1.6 ^{+1.1} _{-0.8}	1.8 ^{+1.2} _{-0.8}	2 ^{+1.3} _{-0.7}	2.2 ^{+1.5} _{-0.7}							
0.6	0.7	/	/	10-18	/	/	1.4 ^{+0.9} _{-0.6}	1.6 ^{+1.1} _{-0.8}	1.8 ^{+1.2} _{-0.8}	2 ^{+1.3} _{-0.7}	2.2 ^{+1.5} _{-0.7}	2.5 ^{+1.7} _{-0.8}	28 ^{+1.9} _{-0.9}						
0.7	0.8	/	/	18-32	/	/	1.6 ^{+1.1} _{-0.8}	1.8 ^{+1.2} _{-0.8}	2 ^{+1.3} _{-0.7}	2.2 ^{+1.5} _{-0.7}	2.5 ^{+1.7} _{-0.8}	2.8 ^{+1.9} _{-0.9}	32 ^{+2.1} _{-1.1}	36 ^{+2.4} _{-1.2}	4 ^{+2.3} _{-1.3}	45 ^{+2.6} _{-1.5}	5 ^{+2.4} _{-1.4}	5.6 ^{+2.7} _{-1.6}	
0.8	1	/	/	32-56	/	/	1.8 ^{+1.2} _{-0.8}	2 ^{+1.3} _{-0.7}	2.2 ^{+1.5} _{-0.7}	2.5 ^{+1.7} _{-0.8}	2.8 ^{+1.9} _{-0.9}	3.2 ^{+2.1} _{-1.1}	3.6 ^{+2.4} _{-1.2}	4 ^{+2.3} _{-1.3}	4.5 ^{+2.6} _{-1.5}	5 ^{+2.4} _{-1.4}	5.6 ^{+2.7} _{-1.6}	6.3 ^{+3.0} _{-1.7}	
1	1.2	/	/	56-10	/	/	2 ^{+1.3} _{-0.7}	2.2 ^{+1.5} _{-0.7}	2.5 ^{+1.7} _{-0.8}	2.8 ^{+1.9} _{-0.9}	3.2 ^{+2.1} _{-1.1}	3.6 ^{+2.4} _{-1.2}	4 ^{+2.3} _{-1.3}	4.5 ^{+2.6} _{-1.5}	5 ^{+2.4} _{-1.4}	5.6 ^{+2.7} _{-1.6}	6.3 ^{+3.0} _{-1.7}	7 ^{+3.2} _{-1.8}	
1.2	1.4	/	/	10-20	/	/	2.2 ^{+1.5} _{-0.7}	2.5 ^{+1.7} _{-0.8}	2.8 ^{+1.9} _{-0.9}	3.2 ^{+2.1} _{-1.1}	3.6 ^{+2.4} _{-1.2}	4 ^{+2.3} _{-1.3}	4.5 ^{+2.6} _{-1.5}	5 ^{+2.4} _{-1.4}	5.6 ^{+2.7} _{-1.6}	6.3 ^{+3.0} _{-1.7}	7 ^{+3.2} _{-1.8}	8 ^{+3.4} _{-1.9}	
1.4	1.7	/	/	20-50	/	/	2.5 ^{+1.7} _{-0.8}	2.8 ^{+1.9} _{-0.9}	3.2 ^{+2.1} _{-1.1}	3.6 ^{+2.4} _{-1.2}	4 ^{+2.3} _{-1.3}	4.5 ^{+2.6} _{-1.5}	5 ^{+2.4} _{-1.4}	5.6 ^{+2.7} _{-1.6}	6.3 ^{+3.0} _{-1.7}	7 ^{+3.2} _{-1.8}	8 ^{+3.4} _{-1.9}	9 ^{+3.6} _{-2.0}	
1.7	2	/	/	50-120	/	/	2.8 ^{+1.9} _{-0.9}	3.2 ^{+2.1} _{-1.1}	3.6 ^{+2.4} _{-1.2}	4 ^{+2.3} _{-1.3}	4.5 ^{+2.6} _{-1.5}	5 ^{+2.4} _{-1.4}	5.6 ^{+2.7} _{-1.6}	6.3 ^{+3.0} _{-1.7}	7 ^{+3.2} _{-1.8}	8 ^{+3.4} _{-1.9}	9 ^{+3.6} _{-2.0}	10 ^{+3.8} _{-2.1}	
2	2.4	/	/	120-250	/	/	3.2 ^{+2.1} _{-1.1}	3.6 ^{+2.4} _{-1.2}	4 ^{+2.3} _{-1.3}	4.5 ^{+2.6} _{-1.5}	5 ^{+2.4} _{-1.4}	5.6 ^{+2.7} _{-1.6}	6.3 ^{+3.0} _{-1.7}	7 ^{+3.2} _{-1.8}	8 ^{+3.4} _{-1.9}	9 ^{+3.6} _{-2.0}	10 ^{+3.8} _{-2.1}	11 ^{+4.0} _{-2.2}	
2.4	2.8	/	/		/	/	3.6 ^{+2.4} _{-1.2}	4 ^{+2.3} _{-1.3}	4.5 ^{+2.6} _{-1.5}	5 ^{+2.4} _{-1.4}	5.6 ^{+2.7} _{-1.6}	6.3 ^{+3.0} _{-1.7}	7 ^{+3.2} _{-1.8}	8 ^{+3.4} _{-1.9}	9 ^{+3.6} _{-2.0}	10 ^{+3.8} _{-2.1}	11 ^{+4.0} _{-2.2}	12 ^{+4.2} _{-2.3}	
QUALITY		(NORMAL)					4 ^{+2.3} _{-1.3}	4.5 ^{+2.6} _{-1.5}	5 ^{+2.4} _{-1.4}	5.6 ^{+2.7} _{-1.6}	6.3 ^{+3.0} _{-1.7}	7 ^{+3.2} _{-1.8}	8 ^{+3.4} _{-1.9}	9 ^{+3.6} _{-2.0}	10 ^{+3.8} _{-2.1}	11 ^{+4.0} _{-2.2}	12 ^{+4.2} _{-2.3}	14 ^{+4.6} _{-2.5}	
							5 ^{+2.4} _{-1.4}	5.6 ^{+2.7} _{-1.6}	6.3 ^{+3.0} _{-1.7}	7 ^{+3.2} _{-1.8}	8 ^{+3.4} _{-1.9}	9 ^{+3.6} _{-2.0}	10 ^{+3.8} _{-2.1}	11 ^{+4.0} _{-2.2}	12 ^{+4.2} _{-2.3}	14 ^{+4.6} _{-2.5}			
							5.6 ^{+2.7} _{-1.6}	6.3 ^{+3.0} _{-1.7}	7 ^{+3.2} _{-1.8}	8 ^{+3.4} _{-1.9}	9 ^{+3.6} _{-2.0}	10 ^{+3.8} _{-2.1}	11 ^{+4.0} _{-2.2}	12 ^{+4.2} _{-2.3}	14 ^{+4.6} _{-2.5}				

TABLE 2 THICKNESS FOR DROP, PRESS AND UPSET FORGINGS AND EJECTOR MARKS FOR DROP AND PRESS FORGINGS (NORMAL TOLERANCES)

DROP, PRESS & UPSET FORGINGS - TOLERANCES FOR THICKNESS; EJECTOR MARKS*														
EJECTOR MARKS	WEIGHT (kg)	DIFFICULTY OF MATERIAL	COMPLEXITY				* (DROP AND PRESS FORGINGS ONLY)							
			S1	S2	S3	S4	0 ABOVE	TO (INCL)	M M					
ABOVE - TO (INCL)	M1	M2	> 0.63 ≤ 1	> 0.32 ≤ 0.63	> 0.16 ≤ 0.32	≤ 0.16	0	16	40	63	100	160	250	> 250
1	0-0.4						1	1.1	1.2	1.4	1.6	1.8	2	
1.2	0.4-1.2						1.1	1.2	1.4	1.6	1.8	2	2.2	
1.6	1.2-2.5						1.2	1.4	1.6	1.8	2	2.2	2.5	
2	2.5-5						1.4	1.6	1.8	2	2.2	2.5	2.8	
2.4	5-8						1.6	1.8	2	2.2	2.5	2.8	3.2	
3.2	8-12						1.8	2	2.2	2.5	2.8	3.2	3.6	
4	12-20						2	2.2	2.5	2.8	3.2	3.6	4	
5	20-36						2.2	2.5	2.8	3.2	3.6	4	4.5	
6.4	36-63						2.5	2.8	3.2	3.6	4	4.5	5	
8	63-110						2.8	3.2	3.6	4	4.5	5	5.6	
10	110-200						3.2	3.6	4	4.5	5	5.6	6.3	
12.6	200-250						3.6	4	4.5	5	5.6	6.3	7	
							4	4.5	5	5.6	6.3	7	8	
							4.5	5	5.6	6.3	7	8	9	
QUALITY (NORMAL)							5	5.6	6.3	7	8	9	10	
							5.6	6.3	7	8	9	10	11	
							6.3	7	8	9	10	11	12	

TABLE 3 STRAIGHTNESS, FLATNESS AND CENTRE TO CENTRE DIMENSIONS FOR DROP, PRESS AND UPSET FORGINGS

DROP, PRESS AND UPSET FORGINGS																
NOTE. QUALITY E DOES NOT APPLY TO UPSET FORGINGS																
RANGE OF TOLERANCES FOR STRAIGHTNESS AND FLATNESS																
LENGTH ABOVE TO (INCL)		MM														
		0 100	100 125	125 160	160 200	200 250	250 315	315 400	400 500	500 630	630 800	800 1000	1000 1250	1250 1600	1600 2000	2000 2500
QUALITY	NORMAL	0.6	0.7	0.8	0.9	1	1.1	1.2	1.4	1.6	1.8	2	2.2	2.5	2.8	3.2
RANGE OF TOLERANCES FOR CENTRE TO CENTRE DIMENSIONS																
LENGTH ABOVE TO (INCL)		MM														
		0 100	100 160	160 200	200 250	250 315	315 400	400 500	500 630	630 800	800 1000	1000 1250				
QUALITY	NORMAL	± 0.3 0.6	± 0.4 0.8	± 0.5 1	± 0.6 1.2	± 0.8 1.6	± 1 2	± 1.2 2.4	± 1.6 3.2	± 2 4	± 2.5 5	± 3.2 6.4				

TABLE 4 FILLET, EDGE RADII AND BURRS FOR DROP, PRESS AND UPSET FORGINGS

DROP, PRESS AND UPSET FORGINGS		
FILLET AND EDGE RADII TOLERANCES		
r MM	+	-
ABOVE - TO (INCL)		
0 - 10	50%	25%
10 - 32	40%	20%
32 - 100	32%	15%
> 100	25%	10%
BURR TOLERANCES (AND PARTING LINE FINIS FOR UPSET FORGINGS)		
WEIGHT (kg)	a	b
ABOVE - TO (INCL)		
0 - 1	1	0.5
1 - 6	1.6	0.8
6 - 40	2.5	1.2
40 - 250	4	2

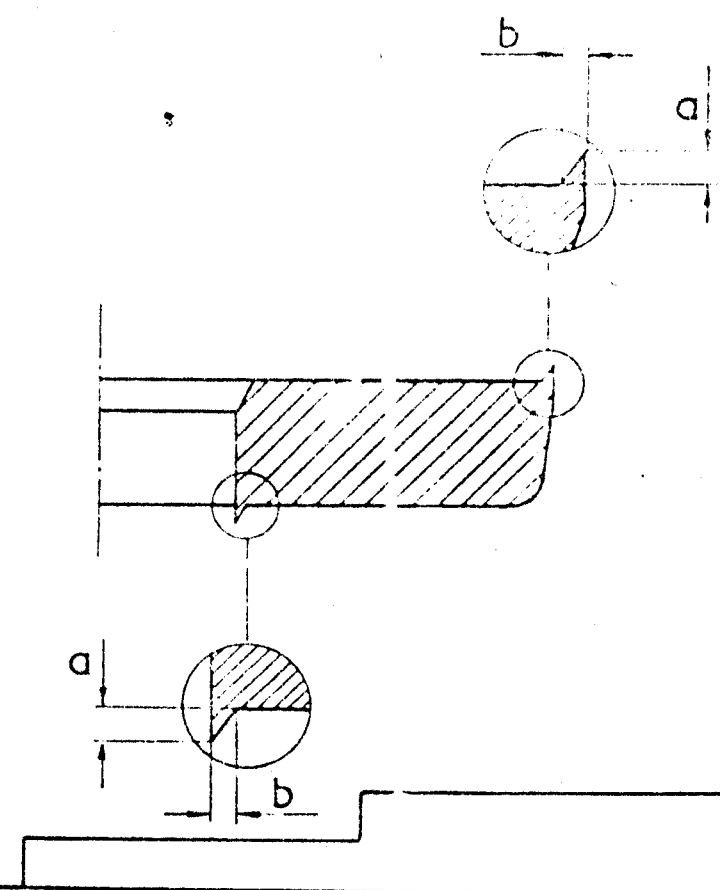

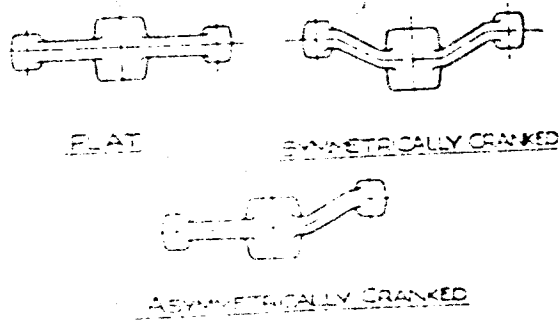
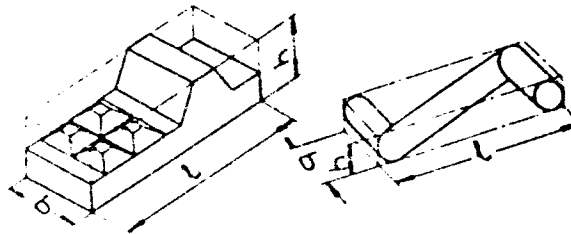
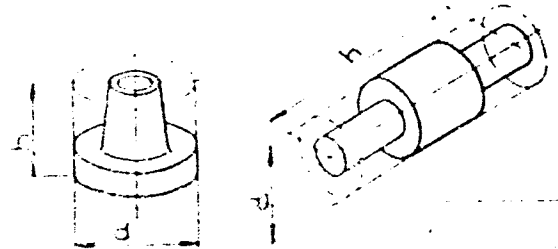

Fig. 1. Die boxes



NOTE :

1. The type of steel used is determined as falling within one of the following categories :
 - a. M1 - steel with carbon content not more than 0.65% and total of specified alloying elements not more than 5%
 - b. M2 - steel with carbon content above 0.65% or total of specified alloying elements above 5%.
2. Complexity factor of a forging is the ratio of the weight of the forging to the weight of the overall shape necessary to accommodate the maximum dimensions of the forging.

The resulting complexity factor is determined as falling within one of the following categories :

- S4 - Upto and including 0.16
- S3 - Above 0.16 upto and including 0.32
- S2 - Above 0.32 upto and including 0.63
- S1 - Above 0.63 upto and including 1.00
