



- 6.07.04 The terminal box shall have sufficient space inside for termination /connection of suitable sized HT cables. Where the specified main cable size demands, adopter/extension box of suitable size shall be provided as a part integral to the motor, for easy termination of the cable.
- 6.07.05 Terminals shall be stud or lead wire type, substantially constructed and thoroughly insulated from the frame.
- 6.07.06 The terminals shall be clearly identified by phase markings, with corresponding direction of rotation marked on the non-driving end of the motor.
- 6.07.07 The terminal box shall be capable of withstanding maximum system fault current for a duration of 0.25 sec.
- 6.07.08 For HT motor, the terminal box shall be phase segregated type. The neutral leads shall be brought out in a separate terminal box (not necessarily phase segregated type) with shorting links for star connection.
- 6.07.09 Motor terminal box shall be furnished with suitable cable lugs and double compression brass glands to match Owner's cable. All threads shall be ISO metric thread only.
- 6.07.10 The gland plate for single core cable shall be non-magnetic type.
- 6.08.00 **Grounding**
- 6.08.01 The frame of each motor shall be provided with two separate and distinct grounding pads complete with tapped hole, GI bolts and washer.
- 6.08.02 The grounding connection shall be suitable for accommodation of ground conductors as follows:
- |                              |                   |
|------------------------------|-------------------|
| Motor above 90 kW            | 50 x 6 mm GI Flat |
| Motor above 30 kW upto 90 kW | 35 x 6 mm GI Flat |
| Motor above 5 kW upto 30 kW  | 25 x 3 mm GI Flat |
| Motor upto 5 kW              | 8 SWG GI Wire     |
- The above sizes shall be superseded by different sizes if so indicated in the relevant clause of the General Electrical Specification.
- 6.08.03 The cable terminal box shall have a separate grounding pad.
- 6.09.00 **Rating Plate**
- In addition to the minimum information required by IS, the following information shall be shown on motor rating plate :
- Temperature rise in °C under rated condition and method of measurement.
  - Degree of protection.
  - Bearing identification no. and recommended lubricant.
  - Location of insulated bearings.

**7.00.00 ACCESSORIES****7.01.00 General**

Accessories shall be furnished, as listed below, or if otherwise required by driven equipment specification or application.

**7.02.00 Space Heater**

7.02.01 Motor of rating 30 kW and above shall be provided with space heaters, suitably located for easy removal or replacement.

7.02.02 The space heater shall be rated 240 V, 1 phase 50 Hz and sized to maintain the motor internal temperature above dew point when the motor is idle.

**7.03.00 Temperature Detectors**

7.03.01 All HT motors shall be provided with minimum four (4) numbers simplex or two (2) numbers duplex platinum resistance type winding temperature detectors per phase.

7.03.02 Each bearing of HT shall be provided with minimum one (1) duplex or two (2) simplex type temperature detectors.

7.03.03 The temperature detector mentioned above shall be resistance type, 3 wire, platinum wound, 100 Ohms at 0°C.

**7.04.00 Indicator/Switch**

7.04.01 Dial type local indicator with alarm contacts shall be provided for the following: -

- a) HT motor bearing temperature.
- b) Hot and cold air temperature of the closed air circuit for CACA and CACW motor.

7.04.02 Flow switches shall be provided for monitoring cooling water flow of CACW motor and oil flow of forced lubrication bearing, if used.

7.04.03 Alarm switch contact rating shall be minimum 0.5 A at 220V D.C. and 5A at 240V A.C.

**7.05.00 Current Transformer for Differential Protection**

7.05.01 Motor above 1000 kW shall be provided with three differential current transformers (PS class) mounted over the neutral leads within the enclosure. Matching three (3) numbers PS class CTs shall be mounted on the switchgear end.

7.05.02 The arrangement shall be such as to permit easy access for C.T. testing and replacement. Current transformer characteristics shall match Owner's requirements to be intimated later.

**7.06.00 Accessory Terminal Box**

7.06.01 All accessory equipment such as space heater, temperature detector, current transformers etc., shall be wired to and terminated in terminal boxes, separate from motor (power) terminal box.

7.06.02 Accessory terminal box shall be complete with double compression brass glands and pressure type terminals to suit owner's cable connections.

**7.07.00 Drain Plug**

Motor shall have drain plugs so located that they will drain the water, resulting from the condensation or other causes from all pockets of the motor casing.

**7.08.00 Lifting Provisions**

Motor weighing 25 kg. or more shall be provided with eye bolt or other adequate provision of lifting.

**7.09.00 Dowel Pins**

The motor shall be designed to permit easy access for drilling holes through motor feet or mounting flange for installation of dowel pins after assembling the motor and driven equipment.

**7.10.00 Painting**

Motor including fan shall be painted with corrosion proof paints. The paint shade shall be as specified in the Annexure.

**8.00.00 TESTS**

8.01.00 Upon completion, each HT & LT motor shall be subject to routine tests as per Schedule-C of Section -I. In addition, any special test called for in the driven equipment specification shall be performed.

8.02.00 Unless and otherwise stated, Six (6) copies of routine test certificates shall be submitted for approval prior to the despatch of the motors from works.

8.03.00 The following type test reports shall be submitted for each type and rating of HT motor:

- a) Degree of protection test for the enclosure followed by IR, HV and no load run test.
- b) Fault level withstand test for each type of terminal box.
- c) Lightning impulse withstand test on the sample coil as per IEC 60034, part-15.
- d) Surge withstand test on inter-turn insulation as per clause no. 5.1.2 of IEC 60034, part-15.

8.03.04 The following type tests shall be performed on a representative sample of 11000V and 3300V motor of each type & rating, even if type test certificates of these tests are submitted by the Bidder for Purchaser's approval:





- a. Measurement of stator resistance (and rotor resistance on slip ring motors).
- b. No load test at rated voltage to determine voltage, current, power input and speeds.
- c. Locked rotor reading of voltage, current, power input and values of torque of motor.
- d. Full load test to determine efficiency, power factor and slip.
- e. Temperature rise test. During heat run test, bearing temperature, Winding temperature, core temperature, coolant flow and its temperature shall be recorded. In case temperature rise test is carried at any load other than rated load, specific approval for test procedure and method has to be obtained.
- f. Momentary overload test.
- g. Test for noise level of motor.

#### 9.00.00 SPARE

Recommended spares for three (3) years operation shall be quoted along with the bid clearly identifying the part numbers with recommended quantities.

#### 10.00.00 DRAWINGS, DATA & MANUALS

Drawings, data & manuals for the motors shall be submitted as indicated below :

##### 10.01.00 Along with the bid

- a) List of the motors
- b) Individual motor data sheet as per Annexures
- c) Scheme & write up on forced lubrication system, if any.
- d) Type test report

##### 10.02.00 After Award of Contract for Information (I)/ Approval (A)

- a) Dimensional General Arrangement drawing (I)
- b) Foundation Plan & Loading (I)
- c) Cable end box details.(I)
- d) Space requirement for rotor removal (I)
- e) Thermal withstands curves hot & cold (I)
- f) Starting and speed torque characteristics at 80%, 100% & 110% voltage (A)
- g) Complete motor data sheet (A)
- h) Erection & Maintenance Manual (I)



## ANNEXURE-A

## DESIGN DATA

## 1.0 AUXILIARY POWER SUPPLY

Supply	Description	Consumer
H.T. Supply	11 kV, 3 $\emptyset$ , 3W, 50 Hz Non-effectively earthed  Fault level 40 KA symm. for 3 second.	Motors above 1500 kW
H.T. Supply	3.3 kV, 3 $\emptyset$ , 3W, 50 Hz Non-effectively earthed  Fault level 40 KA symm. for 3 second.	Motors above 160kW upto 1500 kW.
L.T. Supply	415V, 3 $\emptyset$ , 3W, 50 Hz Effectively earthed  Fault level 50 KA symm. for 1 seconds.	Motors above 200W upto 160 kW
	240V, 1 $\emptyset$ , 2W, 50 Hz Effectively earthed	Motors below 200W Lighting, space heating, A.C. control protective devices
D.C. Supply	220V, 2W, unearthed  Fault level 25* KA for 1 second (Min.)	D.C. alarm, control protective devices

\* However actual value shall be substantiated by the bidder through calculation.

## 2.0 RANGE OF VARIATION

## A.C. Supply

Voltage	:	$\pm 10\%$
Frequency	:	$\pm 5\%$
Combined Volt & frequency	:	10% (absolute sum)

## D.C. Supply

Voltage	:	190 to 240 Volt
---------	---	-----------------

3.0 Paint Shade : RAL 7032





TITLE

## LV MOTORS DATA SHEET-A

**SAGARDIGHI THERMAL POWER PROJECT  
1 x 660 MW UNIT NO. 5, PHASE – III**

SPECIFICATION NO.

VOLUME II B

SECTION D

REV NO. 00 DATE 05.04.21

SHEET 1 OF 1

- 1.0 Design ambient temperature : 50 °C
- 2.0 Maximum acceptable kW rating of LV motor : Upto & Including 160KW
- 3.0 Installation (Indoors/ Outdoors) : As required
- 4.0 Details of supply system
- a) Rated voltage (with variation) : 415V ± 10%
- b) Rated frequency (with variation) : 50 Hz (Variation: +5% TO –5%)
- c) Combined voltage & freq. variation : 10% (sum of absolute values)
- d) System fault level at rated voltage : 50 kA for 1 sec
- e) Short time rating for terminal boxes
- \*Above 90 kW upto & including 160kW(Breaker Controlled) : 50 KA for 0.25 sec.
- \* Rated upto & including 90 kW (Contactor Controlled) : 50 KA protected by MCCB
- f) LV System grounding : Solidly
- 5.0 Class of insulation : Class 'F', with temp rise limited to class B.
- 6.0 Minimum voltage for starting : 80% of rated voltage
- 7.0 Power cables data : Shall be given during Detailed engg.
- 8.0 Earth Conductor Size & Material : Shall be given during Detailed engg.
- 9.0 Space heater supply (**30KW & ABOVE**) : 240 V, 1Φ , 50 Hz
- 10.0 Rating up to which Single phase motor : Acceptable below 0.20 Kw
- 11.0 Locked rotor current
- a) Limit as percentage of FLC : As per IS 12615
- 12.0 Makes : BHEL/ Customer approval (Package owner to take care)
- 13.0 Paint shade : RAL 7032
- 15.0 Additional tests : As per QP
- 14.0 Degree Of protection for motor/ terminal box : IP 55

\* LT motors of continuous duty shall be energy efficient IE3 class conforming to IS-12615

15.0 TESTING REQUIREMENTS: IN LINE WITH SPECIFICATION

➤ **Also detailed Customer spec. for Motors is to be referred as enclosed with technical spec.**

	<b>MANUFACTURER/ BIDDER/ SUPPLIER NAME &amp; ADDRESS</b>	<b>STANDARD QUALITY PLAN</b>		SPEC. NO :	DATE:
		CUSTOMER :		QP NO.: PE-QP-999-Q-006, REV-02	DATE: 17.04.2020
		PROJECT:		PO NO.:	DATE:
		ITEM: AC ELECT. MOTORS UPTO 55KW (LV (415V))	SYSTEM:	SECTION: II	SHEET 1 of 2

S. NO.	COMPONENT & OPERATIONS	CHARACTERISTICS	CLASS	TYPE OF CHECK	QUANTUM OF CHECK		REFERENCE DOCUMENT	ACCEPTANCE NORMS	FORMAT OF RECORD	AGENCY				REMARKS
					M	C/ N				D	**			
1	2	3	4	5			6	7	8		9		M	C
1.0	ASSEMBLY	1.WORKMANSHIP	MA	VISUAL	100%	-	MFG. SPEC.	MFG. SPEC.	LOG BOOK		P	-	-	
		2.DIMENSIONS	MA	VISUAL	100%	-	MFG. DRG./ MFG. SPEC.	MFG. DRG./ MFG. SPEC.	LOG BOOK		P	-	-	
		3.CORRECTNESS COMPLETENESS TERMINATIONS/ MARKING/ COLOUR CODE	MA	VISUAL	100%	-	MFG.SPEC./	MFG.SPEC.	LOG BOOK		P	-	-	
2.0	PAINTING	1.SHADE	MA	VISUAL	SAMPLE	-	MFG. SPEC/ APPROVED DATASHEET	MFG. SPEC/ APPROVED DATASHEET	LOG BOOK	✓	P	V	-	
3.0	TESTS	1.ROUTINE TEST INCLUDING SPECIAL TEST	MA	VISUAL	100%	-	IS-325 / IS-12615/ APPROVED DATA SHEET	IS-325 / IS-12615/ APPROVED DATA SHEET	TEST/ INSPN. REPORT	✓	P	V*	-	* NOTE -1
		2.OVERALL DIMENSIONS & ORIENTATION	MA	MEASUREMENT & VISUAL	100%	-	APPROVED DRG/ DATA SHEET	APPROVED DRG/ DATA SHEET	TEST/ INSPN. REPORT	✓	P	V*	-	* NOTE -1 & NOTE-2

BHEL					
ENGINEERING			QUALITY		
Sign & Date	Name		Sign & Date	Name	
Prepared by:	HEMA KUSHWAHA		Checked by:	KUNAL GANDHI	
Reviewed by:	PRAVEEN DUTTA		Reviewed by:	RITESH KUMAR JAISWAL	

BIDDER/ SUPPLIER	
Sign & Date	
Seal	

FOR CUSTOMER REVIEW & APPROVAL			
Doc No:			
Sign & Date	Name	Seal	
Reviewed by:			
Approved by:			

	<b>MANUFACTURER/ BIDDER/ SUPPLIER NAME &amp; ADDRESS</b>	<b>STANDARD QUALITY PLAN</b>		SPEC. NO :	DATE:
		CUSTOMER :		QP NO.: PE-QP-999-Q-006, REV-02	DATE: 17.04.2020
		PROJECT:		PO NO.:	DATE:
		ITEM: AC ELECT. MOTORS UPTO 55KW (LV (415V))	SYSTEM:	SECTION: II	SHEET 2 of 2

		3.NAMEPLATE DETAILS	MA	VISUAL	100%	-	IS-325 / IS-12615 / APPROVED DATA SHEET	SAME AS COL. 7	TEST/ INSPN. REPORT	✓	P	V	-	
4.0	PACKING	SURFACE FINISH & COMPLETENESS	MA	VISUAL	100%	100%	AS PER MFG. STANDARD / (#)	AS PER MFG. STANDARD / (#).	INSPC. REPORT	✓	P	W	-	(#) REFER NOTE-8

**NOTES:**

1. Routine tests on 100% motors shall be done by the vendor. However, BHEL/ Customer shall witness routine tests on random samples. The sampling plan shall be mutually agreed upon.
2. For exhaust/ventilation fan motors of rating up to 1.5 KW, only routine test certificates shall be furnished for scrutiny.
3. In case test certificates for these tests on similar type, size and design of motor from independent laboratory are available, the same is valid for 5 years.
4. BHEL reserves the right to perform repeat test, if required.
5. After packing and prior to issue MDCC, photographs of items to be despatched shall be sent to BHEL for review.
6. In case of any changes in QP commented by customer at contract stage, same shall be carried out by bidder without any implication to BHEL/ Customer.
7. Project specific QP to be developed based on customer requirement.
8. For export job, BHEL technical specification for seaworthy packing to be followed.
9. Packing shall be suitable for storage at site in tropical climate conditions.
10. Latest revision/ year of issue of all the standards (IS/ ASME/ IEC etc.) indicated in QP shall be referred.

**LEGENDS:**

\*RECORDS, INDENTIFIED WITH "TICK"(✓) SHALL BE ESSENTIALLY INCLUDED BY SUPPLIER IN QA DOCUMENTATION,  
 \*\* M: SUPPLIER/ MANUFACTURER/ SUB-SUPPLIER, B: MAIN SUPPLIER/ BHEL/ THIRD PARTY INSPECTION AGENCY, C: CUSTOMER,  
 P: PERFORM, W: WITNESS, V: VERIFICATION, AS APPROPRIATE  
 MA: MAJOR, MI: MINOR, CR: CRITICAL  
 D: DOCUMENTATION

BHEL					BIDDER/ SUPPLIER		FOR CUSTOMER REVIEW & APPROVAL			
ENGINEERING			QUALITY		Sign & Date		Doc No:			
	Sign & Date	Name		Sign & Date	Name	Seal		Sign & Date	Name	Seal
Prepared by:		HEMA KUSHWAHA	Checked by:		KUNAL GANDHI					
Reviewed by:		PRAVEEN DUTTA	Reviewed by:		RITESH KUMAR JAISWAL					

	<b>MANUFACTURER/ BIDDER/ SUPPLIER NAME &amp; ADDRESS</b>	<b>STANDARD QUALITY PLAN</b>		<b>SPEC. NO.:</b>	
		<b>CUSTOMER :</b>		<b>QP NO.:</b> PE-QP-999-Q-007, REV-04	
		<b>PROJECT:</b>		<b>PO NO.:</b>	
		<b>ITEM: AC ELECT. MOTORS 55 KW &amp; ABOVE (LV (415V))</b>		<b>SYSTEM:</b>	
<b>DATE:17.04.2020</b>					
<b>SHEET 1 OF 9</b>					

SI No.	Component & Operations	Characteristics	Class	Type of Check	Quantum Of check		Reference Document	Acceptance NORMS	FORMAT OF RECORD		AGENCY			
					M	C/N			9	*	**	D	M	C
1.0	RAW MATERIAL & BOUGHT OUT CONTROL													
1.1	SHEET STEEL, PLATES, SECTION, EYEBOLTS	1.SURFACE CONDITION	MA	VISUAL	100%	-	-	FREE FROM BLINKS, CRACKS, WAVINESS ETC	LOG BOOK		P	-	-	
		2.DIMENSIONS	MA	MEASUREMENT	SAMPLE	-	MANUFACTURER'S DRG./SPEC	MANUFACTURER'S DRG./SPEC	LOG BOOK		P	-	-	
		3.PROOF LOAD TEST (EYE BOLT)	MA	MECH. TEST	SAMPLE	-	MANUFACTURER'S DRG./SPEC	MANUFACTURER'S DRG./SPEC	TEST REPORT		P/V	-	-	
1.2	HARDWARES	1.SURFACE CONDITION	MA	VISUAL	100%	-	-	FREE FROM CRACKS, UN-EVENNESS ETC.	TEST REPORT		P	-	-	
		2.PROPERTY CLASS	MA	VISUAL	SAMPLES	-	MANUFACTURER'S DRG./SPEC	MANUFACTURER'S DRG./SPEC	TC		P/V	-	-	PROPERTY CLASS MARKING SHALL BE CHECKED BY THE VENDOR
1.3	CASTING	1.SURFACE CONDITION	MA	VISUAL	100%	-	MANUFACTURER'S DRG./SPEC	FREE FROM CRACKS, BLOW HOLES ETC.	LOG BOOK		P/V	-	-	
		2.CHEM. & PHY. PROP.	MA	CHEM & MECH TEST	1/HEAT NO.	-	MANUFACTURER'S DRG./SPEC	MANUFACTURER'S DRG./SPEC	TC		P/V	-	-	HEAT NO. SHALL BE VERIFIED
		3.DIMENSIONS	MA	MEASUREMENT	100%	-	MANUFACTURER'S DRG.	MANUFACTURER'S DRG.	LOG BOOK		P/V	-	-	
1.4	PAINT & VARNISH	1.MAKE, SHADE, SHELF LIFE & TYPE	MA	VISUAL	100%	CONTINUOUS	MANUFACTURER'S DRG./SPEC	MANUFACTURER'S DRG./SPEC	LOG BOOK		P/V	-	-	

BHEL					
ENGINEERING			QUALITY		
Sign & Date	Name		Sign & Date	Name	
Prepared by:	HEMA KHUSHWAHA	Checked by:		KUNAL GANDHI	
Reviewed by:	PRAVEEN DUTTA	Reviewed by:		R K JAISWAL	

BIDDER/ SUPPLIER	
Sign & Date	
Seal	

FOR CUSTOMER REVIEW & APPROVAL			
Doc No:			
	Sign & Date	Name	Seal
Reviewed by:			
Approved by:			

	<b>MANUFACTURER/ BIDDER/ SUPPLIER NAME &amp; ADDRESS</b>	<b>STANDARD QUALITY PLAN</b>		<b>SPEC. NO.:</b>		
		<b>CUSTOMER :</b>		<b>QP NO.:</b> PE-QP-999-Q-007, REV-04		<b>DATE:</b> 17.04.2020
		<b>PROJECT:</b>		<b>PO NO.:</b>		
		<b>ITEM: AC ELECT. MOTORS 55 KW &amp; ABOVE (LV (415V))</b>		<b>SYSTEM:</b>	<b>SECTION: II</b>	<b>SHEET 2 OF 9</b>

SI No.	Component & Operations	Characteristics	Class	Type of Check	Quantum Of check		Reference Document	Acceptance NORMS	FORMAT OF RECORD	AGENCY				
					6	C/N				9	.	**		
												D	M	C
1.5	SHAFT (FORGED OR ROLLED)	1. SURFACE COND.	MA	VISUAL	100%	-	-	FREE FROM VISUAL DEFECTS	LOG BOOK		P	-	-	VENDOR'S APPROVAL IDENTIFICATION SHALL BE MAINTAINED
		2. CHEM. & PHYSICAL PROPERTIES	MA	CHEM. & PHYSICAL TESTS	1/HEAT NO. OR HEAT TREATMENT BATCH NO	-	MANUFACTURER'S DRG./ SPEC.	MANUFACTURER'S DRG./ STD.	TC		P/V	-	-	
		3. DIMENSIONS	MA	MEASUREMENT	100%	-	MANUFACTURER'S DRG./ SPEC.	MANUFACTURER'S DRG.	LOG BOOK		P/V	-	-	
		4. INTERNAL FLAWS	CR	ULTRASONIC TEST	100%	-	ASTM-A388	MANUFACTURER'S STD.	INSPECTION REPORT	✓	P/W	V	-	FOR DIA OF 55 MM & ABOVE
1.6	SPACE HEATERS, CONNECTORS, TERMINAL BLOCKS, CABLES, CABLE LUGS, CARBON BRUSH TEMP. DETECTORS, RTD, BTD'S	1. MAKE & RATING	MA	VISUAL	100%	-	MANUFACTURER'S DRG./STD.	MANUFACTURER'S DRG./STD.	INSPECTION REPORT		P/V	-	-	
		2. PHYSICAL COND.	MA	VISUAL	100%	-	MANUFACTURER'S DRG./STD.	NO PHYS. DAMAGE, NO ELECTRICAL DISCONTINUITY	INSPECTION REPORT		P/V	-	-	
		3. DIMENSIONS (WHEREVER APPLICABLE)	MA	MEASUREMENT	SAMPLE	-	MANUFACTURER'S DRG./ STD	MANUFACTURER'S DRG. / STD.	INSPECTION REPORT		P/V	-	-	
		4. PERFORMANCE/ CALIBRATION	MA	TEST	100%	-	MANUFACTURER'S DRG./ STD	MANUFACTURER'S DRG. / STD.	TEST REPORT		P/V	-	-	

BHEL					
ENGINEERING			QUALITY		
	Sign & Date	Name		Sign & Date	Name
Prepared by:		HEMA KHUSHWAHA	Checked by:		KUNAL GANDHI
Reviewed by:		PRAVEEN DUTTA	Reviewed by:		R K JAISWAL

BIDDER/ SUPPLIER	
Sign & Date	
Seal	

FOR CUSTOMER REVIEW & APPROVAL			
Doc No:			
	Sign & Date	Name	Seal
Reviewed by:			
Approved by:			

	<b>MANUFACTURER/ BIDDER/ SUPPLIER NAME &amp; ADDRESS</b>	<b>STANDARD QUALITY PLAN</b>		<b>SPEC. NO :</b>		
		<b>CUSTOMER :</b>		QP NO.: PE-QP-999-Q-007, REV-04		DATE:17.04.2020
		<b>PROJECT:</b>		PO NO.:		
		ITEM: AC ELECT. MOTORS 55 KW & ABOVE (LV (415V))		SYSTEM:	SECTION: II	SHEET 3 OF 9

SI No.	Component & Operations	Characteristics	Class	Type of Check	Quantum Of check		Reference Document	Acceptance NORMS	FORMAT OF RECORD	AGENCY						
					6					7	8	9	*	**		
					M	C/N									D	M
1.7	OTHER INSULATING MATERIALS LIKE SLEEVES, BINDINGS CORDS, PAPERS, PRESS BOARDS ETC.	1. SURFACE COND. ETC.	MA	VISUAL	100%	-	-	NO VISUAL DEFECTS	TEST REPORT		P/V	-	-			
		2.DIMENSION/BORE DIA, WALL THICKNESS, BDV AS RECEIVED, BDV AFTER FOLDING AT 180°	MA	TEST	SAMPLE	-	MANUFACTURER'S STD.	MANUFACTURER'S STD.	LOG BOOK AND OR SUPPLIER'S TC		P/V	-	-			
1.8	SHEET STAMPING (PUNCHED)	1. SURFACE COND.	MA	VISUAL	100%	-	-	NO VISUAL DEFECTS (FREE FROM BURS)	LOG BOOK		P	-	-			
		2.DIMENSIONS INCLUDING BURS HEIGHT	MA	MEASUREMENT	SAMPLE	-	MANUFACTURER'S DRG. .	MANUFACTURER'S DRG.	LOG BOOK		P/V	-	-			
		3. ACCEPTANCE TESTS	MA	ELECT. & MECH TESTS	SAMPLE	-	MANUFACTURER'S DRG./ STD.	MANUFACTURER'S DRG./ STD.	TC		P/V	-	-			
1.9	CONDUCTORS	1. SURFACE FINISH	MA	VISUAL	100%	-	-	FREE FROM VISUAL DEFECTS	LOG BOOK		*P/V	-	-	* MOTOR MANUFACTURER TO CONDUCT VISUAL CHECK FOR SURFACE FINISH ON RANDOM BASIS (10% SAMPLE) AT HIS WORKS AND MAINTAIN RECORD FOR VERIFICATION BY		
		2.ELECT. PROP. & MECH. PROP	MA	ELECT. & MECH.TEST	SAMPLES	-	MANUFACTURER'S DRG./ SPEC.	MANUFACTURER'S / SPEC.	TC & VENDOR'S TEST REPORTS		P/V	-	-			

BHEL					
ENGINEERING			QUALITY		
	Sign & Date	Name		Sign & Date	Name
Prepared by:		HEMA KHUSHWAHA	Checked by:		KUNAL GANDHI
Reviewed by:		PRAVEEN DUTTA	Reviewed by:		R K JAISWAL

BIDDER/ SUPPLIER	
Sign & Date	
Seal	

FOR CUSTOMER REVIEW & APPROVAL			
Doc No:			
	Sign & Date	Name	Seal
Reviewed by:			
Approved by:			

	<b>MANUFACTURER/ BIDDER/ SUPPLIER NAME &amp; ADDRESS</b>	<b>STANDARD QUALITY PLAN</b>		<b>SPEC. NO.:</b>		
		<b>CUSTOMER :</b>		<b>QP NO.:</b> PE-QP-999-Q-007, REV-04		<b>DATE:</b> 17.04.2020
		<b>PROJECT:</b>		<b>PO NO.:</b>		
		<b>ITEM:</b> AC ELECT. MOTORS 55 KW & ABOVE (LV (415V))		<b>SYSTEM:</b>		<b>SECTION:</b> II

SI No.	Component & Operations	Characteristics	Class	Type of Check	Quantum Of check		Reference Document	Acceptance NORMS	FORMAT OF RECORD	AGENCY								
					6					7	8	9	.	**	D	M	C	N
					M	C/N												
1.10	BEARINGS	3.DIMENSIONS 1.MAKE & TYPE 2.DIMENSIONS	MA MA MA	MEASUREMENT VISUAL MEASUREMENT	SAMPLES 100% SAMPLE	- - -	MANUFACTURER'S DRG / SPEC. MANUFACTURER'S DRG / APPROVED DATASHEET APPROVED DATASHEET	MANUFACTURER'S / SPEC. MANUFACTURER'S DRG / APPROVED DATASHEET APPROVED DATASHEET / BEARING MANUF'S CATALOGUES	LOG BOOK LOG BOOK LOG BOOK		P/V P/V P/V	- - -	- - -					
1.11	SLIP RING (WHEREVER APPLICABLE)	1.SURFACE COND. 2.DIMENSIONS 3.TEMP.WITH-STAND CAPACITY	MA MA MA	VISUAL MEASUREMENT ELECT.TEST	100% SAMPLE SAMPLE	- - -	- MANUFACTURER'S DRG MANUFACTURER'S STD / APPROVED DATASHEET	FREE FROM VISUAL DEFECTS MANUFACTURER'S DRG MANUFACTURER'S STD / APPROVED DATASHEET	LOG BOOK LOG BOOK LOG BOOK		P P P/V	- - -	- - -					
1.12	OIL SEALS & GASKETS	1.MATERIAL OF GASKET 2.SURFACE COND. 3.DIMENSIONS	MA MA MA	VISUAL VISUAL MEASUREMENT	100% 100% SAMPLE	- - -	MANUFACTURER'S DRG/SPECS - MANUFACTURER'S DRG	MANUFACTURER'S DRG / SPECS. FREE FROM VISUAL DEFECTS MANUFACTURER'S DRG	LOG BOOK LOG BOOK LOG BOOK		P P P	- - -	- - -					

BHEL					
ENGINEERING			QUALITY		
	Sign & Date	Name		Sign & Date	Name
Prepared by:		HEMA KHUSHWAHA	Checked by:		KUNAL GANDHI
Reviewed by:		PRAVEEN DUTTA	Reviewed by:		R K JAISWAL

BIDDER/ SUPPLIER	
Sign & Date	
Seal	

FOR CUSTOMER REVIEW & APPROVAL			
Doc No:			
	Sign & Date	Name	Seal
Reviewed by:			
Approved by:			

	<b>MANUFACTURER/ BIDDER/ SUPPLIER NAME &amp; ADDRESS</b>	<b>STANDARD QUALITY PLAN</b>		<b>SPEC. NO.:</b>		
		<b>CUSTOMER :</b>		<b>QP NO.:</b> PE-QP-999-Q-007, REV-04		<b>DATE:</b> 17.04.2020
		<b>PROJECT:</b>		<b>PO NO.:</b>		
		<b>ITEM:</b> AC ELECT. MOTORS 55 KW & ABOVE (LV (415V))		<b>SYSTEM:</b>	<b>SECTION:</b> II	<b>SHEET 5 OF 9</b>

SI No.	Component & Operations	Characteristics	Class	Type of Check	Quantum Of check		Reference Document	Acceptance NORMS	FORMAT OF RECORD		AGENCY							
					M	C/N			9	*	**	D	M	C	N			
2.0	IN PROCESS																	
2.1	STATOR FRAME WELDING (IN CASE OF FABRICATED STATOR )	1.WORKMANSHIP & CLEANNESS	MA	VISUAL	100%	-	MANUFACTURER'S DRG	GOOD FINISH	LOG BOOK			P/W	-	-				
		2.DIMENSIONS	MA	MEASUREMENT	100%	-	MANUFACTURER'S DRG	MANUFACTURER'S DRG	LOG BOOK			P	-	-				
2.2	MACHINING	1.FINISH	MA	VISUAL	100%	-	-DO-	GOOD FINISH	LOG BOOK			P	-	-				
		2.DIMENSIONS	MA	MEASUREMENT	100%	-	MANUFACTURER'S DRG	MANUFACTURER'S DRG	LOG BOOK			P	-	-				
		3.SHAFT SURFACE FLOWS	MA	PT	100%	-	MANUFACTURER'S STD./ASTM-E165	MANUFACTURER'S STD./APPROVED DATASHEET.	LOG BOOK	✓		P	V	-				
2.3	PAINING	1.SURFACE PREPARATION	MA	VISUAL	100%	-	MANUFACTURER'S STD./APPROVED DATASHEET	MANUFACTURER'S STD./APPROVED DATASHEET	LOG BOOK			P	-	-				
		2.PAINT THICKNESS (BOTH PRIMER & FINISH COAT)	MA	MEASUREMENT BY ELCOMETER	SAMPLE	-	MANUFACTURER'S STD./APPROVED DATASHEET	MANUFACTURER'S STD./APPROVED DATASHEET	LOG BOOK			P	-	-				
		3.SHADE	MA	VISUAL	SAMPLE	-	MANUFACTURER'S STD./APPROVED DATASHEET	MANUFACTURER'S STD./APPROVED DATASHEET	LOG BOOK			P	-	-				
		4.ADHESION	MA	CROSS CUTTING & TAPE TEST	SAMPLE	-	MANUFACTURER'S STD./APPROVED DATASHEET	MANUFACTURER'S STD./APPROVED DATASHEET	LOG BOOK			P	-	-				

BHEL					
ENGINEERING			QUALITY		
	Sign & Date	Name		Sign & Date	Name
Prepared by:		HEMA KHUSHWAHA	Checked by:		KUNAL GANDHI
Reviewed by:		PRAVEEN DUTTA	Reviewed by:		R K JAISWAL

BIDDER/ SUPPLIER	
Sign & Date	
Seal	

FOR CUSTOMER REVIEW & APPROVAL			
Doc No:			
	Sign & Date	Name	Seal
Reviewed by:			
Approved by:			

	<b>MANUFACTURER/ BIDDER/ SUPPLIER NAME &amp; ADDRESS</b>	<b>STANDARD QUALITY PLAN</b>		<b>SPEC. NO.:</b>		
		<b>CUSTOMER :</b>		<b>QP NO.:</b> PE-QP-999-Q-007, REV-04		<b>DATE:</b> 17.04.2020
		<b>PROJECT:</b>		<b>PO NO.:</b>		
		<b>ITEM:</b> AC ELECT. MOTORS 55 KW & ABOVE (LV (415V))		<b>SYSTEM:</b>	<b>SECTION:</b> II	<b>SHEET 6 OF 9</b>

SI No.	Component & Operations	Characteristics	Class	Type of Check	Quantum Of check		Reference Document	Acceptance NORMS	FORMAT OF RECORD	AGENCY				
					M	C/N				9	*	**	D	M
1	2	3	4	5	6		7	8	9	*	**			
2.4	SHEET STACKING	1.COMPLETENESS	MA	MEASUREMENT	SAMPLE	-	MANUFACTURER'S STD.	MANUFACTURER'S STD.	LOG BOOK			P	-	-
		2.COMPRESSION & TIGHTENING	MA	MEASUREMENT	100%	-	MANUFACTURER'S STD.	MANUFACTURER'S STD.	LOG BOOK			P	-	-
2.5	WINDING	1.COMPLETENESS	CR	VISUAL	100%	-	MANUFACTURER'S STD./APPROVED DATASHEET	MANUFACTURER'S STD./APPROVED DATASHEET	LOG BOOK			P	-	-
		2.CLEANLINESS	CR	VISUAL	100%	-	MANUFACTURER'S STD./APPROVED DATASHEET	MANUFACTURER'S STD./APPROVED DATASHEET	LOG BOOK			P	-	-
		3.IR-HV-IR	CR	ELECT. TEST	100%	-	IS-325//IS-12615//IEC-60034 PART-1	IS-325//IS-12615//IEC-60034 PART-1	TEST/INSPC. REPORT	✓		P	V	-
		4.RESISTANCE	CR	ELECT. TEST	100%	-	IS-325//IS-12615//IEC-60034 PART-1	IS-325//IS-12615//IEC-60034 PART-1	TEST/INSPC. REPORT	✓		P	V	-
		5.INTERTURN INSULATION	CR	ELECT. TEST	100%	-	IS-325//IS-12615//IEC-60034 PART-1	IS-325//IS-12615//IEC-60034 PART-1	TEST/INSPC. REPORT			P	-	-
2.6	IMPREGNATION	1.VISCOSCITY	MA	PHY. TEST	AT STARTING	-	MANUFACTURER'S STANDARD	MANUFACTURER'S STANDARD	LOG BOOK			P	-	-
		2.TEMP. PRESSURE VACCUM	MA	PROCESS CHECK	CONTINUOUS	-	MANUFACTURER'S STANDARD	MANUFACTURER'S STANDARD	LOG BOOK			P	-	-
		3.NO. OF DIPS	MA	PROCESS CHECK	CONTINUOUS	-	MANUFACTURER'S STANDARD	MANUFACTURER'S STANDARD	LOG BOOK	✓		P	V	-
THREE DIPS TO BE GIVEN														

BHEL					
ENGINEERING			QUALITY		
	Sign & Date	Name		Sign & Date	Name
Prepared by:		HEMA KHUSHWAHA	Checked by:		KUNAL GANDHI
Reviewed by:		PRAVEEN DUTTA	Reviewed by:		R K JAISWAL

BIDDER/ SUPPLIER	
Sign & Date	
Seal	

FOR CUSTOMER REVIEW & APPROVAL			
Doc No:			
	Sign & Date	Name	Seal
Reviewed by:			
Approved by:			

	<b>MANUFACTURER/ BIDDER/ SUPPLIER NAME &amp; ADDRESS</b>	<b>STANDARD QUALITY PLAN</b>		<b>SPEC. NO.:</b>		
		<b>CUSTOMER :</b>		<b>QP NO.:</b> PE-QP-999-Q-007, REV-04		<b>DATE:</b> 17.04.2020
		<b>PROJECT:</b>		<b>PO NO.:</b>		
		<b>ITEM:</b> AC ELECT. MOTORS 55 KW & ABOVE (LV (415V))		<b>SYSTEM:</b>	<b>SECTION:</b> II	<b>SHEET 7 OF 9</b>

SI No.	Component & Operations	Characteristics	Class	Type of Check	Quantum Of check		Reference Document	Acceptance NORMS	FORMAT OF RECORD	AGENCY			
					M	C/N				D	M	C	N
2.7	COMPLETE STATOR ASSEMBLY	4.DURATION 1.COMPACTNESS & CLEANLINESS	MA MA	PROCESS CHECK VISUAL	CONTINUOUS 100%	- -	MANUFACTURER'S STANDARD MANUFACTURER'S STANDARD	MANUFACTURER'S STANDARD MANUFACTURER'S STANDARD	LOG BOOK LOG BOOK	✓ -	P P	V -	- -
2.8	BRAZING/COMPRESSION JOINT	1.COMPLETENESS 2.SOUNDNESS	CR CR	VISUAL MALLETT TEST & UT	100% 100%	- -	MANUFACTURER'S STANDARD MANUFACTURER'S STANDARD	MANUFACTURER'S STANDARD MANUFACTURER'S STANDARD	LOG BOOK TEST/INSPC. REPORT	- ✓	P P	- V	- -
2.9	COMPLETE ROTOR ASSEMBLY	3.HV 1.RESIDUAL UNBALANCE	MA CR	ELECT. TEST DYN. BALANCE	100% 100%	- -	MANUFACTURER'S STANDARD MANUFACTURER'S SPEC./ ISO 1940	MANUFACTURER'S STANDARD MANUFACTURER'S DWG.	TEST/INSPC. REPORT LOG BOOK	✓ -	P P	V -	- -
2.10	ASSEMBLY	2.SOUNDNESS OF DIE CASTING 1.ALIGNMENT 2.WORKMANSHIP 3.AXIAL PLAY 4.DIMENSIONS 5.CORRECTNESS, COMPLETENESS TERMINATIONS/ MARKING/ COLOUR CODE 6. RTD, BTD & SPACE HEATER MOUNTING.	CR MA MA MA MA MA	ELECT. (GROWLER TEST) MEAS. VISUAL MEAS. MEAS. VISUAL VISUAL	100% 100% 100% 100% 100% 100%	- - - - - -	MANUFACTURER'S SPEC. MANUFACTURER'S SPEC. MANUFACTURER'S SPEC. MANUFACTURER'S DRG./ MANUFACTURER'S SPEC. MANUFACTURER'S SPEC. MANUFACTURER'S SPEC.	MANUFACTURER'S SPEC. MANUFACTURER'S SPEC. MANUFACTURER'S SPEC. MANUFACTURER'S DRG./ MANUFACTURER'S SPEC. MANUFACTURER'S SPEC. MANUFACTURER'S SPEC.	TEST/INSPC. REPORT LOG BOOK LOG BOOK LOG BOOK LOG BOOK LOG BOOK	✓ - - ✓ - -	P P P P P P	V - - V - -	- - - - - -

BHEL					
ENGINEERING			QUALITY		
	Sign & Date	Name		Sign & Date	Name
Prepared by:		HEMA KHUSHWAHA	Checked by:		KUNAL GANDHI
Reviewed by:		PRAVEEN DUTTA	Reviewed by:		R K JAISWAL

BIDDER/ SUPPLIER	
Sign & Date	
Seal	

FOR CUSTOMER REVIEW & APPROVAL			
Doc No:			
	Sign & Date	Name	Seal
Reviewed by:			
Approved by:			

	<b>MANUFACTURER/ BIDDER/ SUPPLIER NAME &amp; ADDRESS</b>	<b>STANDARD QUALITY PLAN</b>		<b>SPEC. NO :</b>		
		<b>CUSTOMER :</b>		<b>QP NO.: PE-QP-999-Q-007, REV-04</b>		<b>DATE:17.04.2020</b>
		<b>PROJECT:</b>		<b>PO NO.:</b>		
		<b>ITEM: AC ELECT. MOTORS 55 KW &amp; ABOVE (LV (415V))</b>		<b>SYSTEM:</b>		<b>SECTION: II</b>

SI No.	Component & Operations	Characteristics	Class	Type of Check	Quantum Of check		Reference Document	Acceptance NORMS	FORMAT OF RECORD	AGENCY								
					6					7	8	9	.	**	D	M	C	N
					M	C/N												
3.0	TESTS	1.TYPE TESTS INCLUDING SPECIAL TESTS	MA	ELECT.TEST	1/TYPE/SIZE	1/TYPE/SIZE	IS-325//IS-12615/APPROVED DATASHEET	IS-325//IS-12615/APPROVED DATASHEET	TEST REPORT	✓	P	W*	-	* NOTE - 1				
		2.ROUTINE TESTS INCLUDING SPECIAL TEST	MA	ELECT.TEST	100%	-	IS-325//IS-12615/APPROVED DATASHEET	IS-325//IS-12615/APPROVED DATASHEET	TEST REPORT	✓	P	√ <sup>§</sup>	-	§ NOTE - 2				
		3.VIBRATION & NOISE LEVEL	MA	ELECT.TEST	100%	-	IS: 12075 / IEC 60034-14 & IS-12065	IS: 12075 / IEC 60034-14 & IS-12065	TEST REPORT	✓	P	√ <sup>§</sup>	-	§ NOTE - 2				
		4.OVERALL DIMENSIONS AND ORIENTATION	MA	MEASUREMENT & VISUAL	100%	100%	APPROVED DRG/DATA SHEET	APPROVED DRG/DATA SHEET &	TEST/INSPC. REPORT	✓	P	W	-					
		5.DEGREE OF PROTECTION	MA	ELECT. & MECH. TEST	1/TYPE/ SIZE	-	IEC 60034-5//IS-12615	APPROVED DATASHEET	TC	✓	P	V	-	TC FROM AN INDEPENDENT LABORATORY, REFER NOTE-3				
		6. MEASUREMENT OF RESISTANCE OF RTD & BTD	MA	ELECT. & MECH. TEST	100%	-	IS-325//IS-12615/IEC-60034 PART-1//IS: 12802	IS-325//IS-12615/IEC-60034 PART-1//IS: 12802	TC	✓	P	√ <sup>§</sup>	-	§ NOTE - 2				
		7. MEASUREMENT OF RESISTANCE, IR OF SPACE HEATER	MA	ELECT. & MECH. TEST	100%	-	IS-325//IS-12615/IEC-60034 PART-1	IS-325//IS-12615/IEC-60034 PART-1	TC	✓	P	√ <sup>§</sup>	-	§ NOTE - 2				
		8. NAME PLATE DETAILS	MA	VISUAL	100%	-	IS-325//IS-12615& DATA SHEET	IS-325//IS-12615 & DATA SHEET	TEST/INSPC. REPORT	✓	P	√ <sup>§</sup>	-	§ NOTE - 2				
		9.EXPLOSION FLAME PROOF NESS (IF SPECIFIED)	MA	EXPLOSION FLAME PROOF TEST	1/TYPE	-	IS 2148 / IEC 60079-1	IS 2148 / IEC 60079-1	TC	✓	P	V	-	TC FROM AN INDEPENDENT LABORATORY, REFER NOTE-3				
		10. PAINT SHADE, THICKNESS & FINISH	MA	VISUAL & MEASUREMENT BY ELKOMETER	SAMPLE	SAMPLE	APPROVED DATASHEET	APPROVED DATASHEET	TC	✓	P	W <sup>§</sup>	-	SAMPLING PLAN TO BE DECIDED BY INSPECTION AGENCY § NOTE - 2				

BHEL					
ENGINEERING			QUALITY		
	Sign & Date	Name		Sign & Date	Name
Prepared by:		HEMA KHUSHWAHA	Checked by:		KUNAL GANDHI
Reviewed by:		PRAVEEN DUTTA	Reviewed by:		R K JAISWAL

BIDDER/ SUPPLIER	
Sign & Date	
Seal	

FOR CUSTOMER REVIEW & APPROVAL			
Doc No:			
	Sign & Date	Name	Seal
Reviewed by:			
Approved by:			

	<b>MANUFACTURER/ BIDDER/ SUPPLIER NAME &amp; ADDRESS</b>	<b>STANDARD QUALITY PLAN</b>		<b>SPEC. NO.:</b>		
		<b>CUSTOMER :</b>		QP NO.: PE-QP-999-Q-007, REV-04		DATE:17.04.2020
		<b>PROJECT:</b>		PO NO.:		
		ITEM: AC ELECT. MOTORS 55 KW & ABOVE (LV (415V))		SYSTEM:		SECTION: II

SI No.	Component & Operations	Characteristics	Class	Type of Check	Quantum Of check		Reference Document	Acceptance NORMS	FORMAT OF RECORD	AGENCY				
1	2	3	4	5	6		7	8	9	*	**			
					M	C/N				D	M	C	N	
4.0	PACKING	SURFACE FINISH & COMPLETENESS	MA	VISUAL	100%	100%	AS PER MANUFACT. STANDARD / (#)	AS PER MANUFACT. STANDARD / (#)	INSPC. REPORT	✓	P	W	-	(#): REFER NOTE-8

**NOTES:**

- 1 DEPENDING UPON THE SIZE AND CRITICALLY, WITNESSING BY BHEL SHALL BE DECIDED.
- 2 ROUTINE TESTS ON 100% MOTORS SHALL BE DONE BY THE VENDOR. HOWEVER, BHEL/CUSTOMER SHALL WITNESS ROUTINE TESTS ON RANDOM SAMPLES. THE SAMPLING PLAN SHALL BE MUTUALLY AGREED UPON.
- 3 IN CASE TEST CERTIFICATES FOR THESE TESTS ON SIMILAR TYPE, SIZE AND DESIGN OF MOTOR FROM INDEPENDENT LABORATORY ARE AVAILABLE, THE SAME IS VALID FOR 5 YEARS.
- 4 BHEL RESERVES THE RIGHT TO PERFORM REPEAT TEST, IF REQUIRED.
- 5 AFTER PACKING AND PRIOR TO ISSUE MDCC, PHOTOGRAPHS OF ITEMS TO BE DESPATCHED SHALL BE SENT TO BHEL PURCHASE GROUP FOR REVIEW.
- 6 IN CASE , ANY CHANGES IN QP COMMENTED BY CUSTOMER AT CONTRACT STAGE SHALL BE CARRIED OUT BY BIDDER WITHOUT ANY IMPLICATION TO BHEL/ CUSTOMER.
- 7 PROJECT SPECIFIC QP TO BE DEVELOPED BASED ON CUSTOMER REQUIREMENT.
- 8 FOR EXPORT JOB, BHEL TECHNICAL SPECIFICATION FOR SEAWORTHY PACKING TO BE FOLLOWED.
- 9 PACKING SHALL BE SUITABLE FOR STORAGE AT SITE IN TROPICAL CLIMATE CONDITIONS.
- 10 LATEST REVISION/ YEAR OF ISSUE OF ALL THE STANDARDS (IS/ ASME/ IEC ETC.) INDICATED IN QP SHALL BE REFERRED.

**LEGENDS:**

\*RECORDS, IDENTIFIED WITH "TICK"(✓) SHALL BE ESSENTIALLY INCLUDED BY SUPPLIER IN QA DOCUMENTATION.  
 \*\* **M:** SUPPLIER/ MANUFACTURER/ SUB-SUPPLIER, **B:** MAIN SUPPLIER/ BHEL/ THIRD PARTY INSPECTION AGENCY, **C:** CUSTOMER,  
**P:** PERFORM, **W:** WITNESS, **V:** VERIFICATION, AS APPROPRIATE  
**MA:** MAJOR, **MI:** MINOR, **CR:** CRITICAL  
**D:** DOCUMENT

BHEL					
ENGINEERING			QUALITY		
	Sign & Date	Name		Sign & Date	Name
Prepared by:		HEMA KHUSHWAHA	Checked by:		KUNAL GANDHI
Reviewed by:		PRAVEEN DUTTA	Reviewed by:		R K JAISWAL

BIDDER/ SUPPLIER	
Sign & Date	
Seal	

FOR CUSTOMER REVIEW & APPROVAL			
Doc No:			
	Sign & Date	Name	Seal
Reviewed by:			
Approved by:			

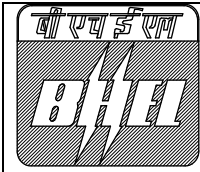

<b>TITLE:</b> <b>1 X 660 MW SAGARDIGHI TPS UNIT NO.5 PHASE III</b>	SPECIFICATION NO. PE-TS-445-155A-A001	
	SECTION : I	
<b>TECHNICAL SPECIFICATION FOR CONDENSATE POLISHING UNIT</b>	<b>SUB-SECTION: IC</b>	
	REV. NO. 02	DATE : 18.04.2022

**SECTION – I**

**SUB-SECTION IC: SPECIFIC TECHNICAL REQUIREMENTS (C&I)**

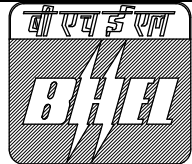
	<b>TITLE:</b>	SPECIFICATION NO. PE-TS-445-155A-A001	
	<b>1 X 660 MW SAGARDIGHI TPS UNIT NO.5 PHASE III</b>	SECTION : I	
	<b>TECHNICAL SPECIFICATION FOR CONDENSATE POLISHING UNIT</b>	<b>SUB-SECTION: IC</b>	
		REV. NO. 02	DATE : 18.04.2022

1. Condensate Polishing Unit (CPU) shall be operated from DCS (BHEL's scope). The operation and control philosophy of CPU has been elaborated in separate section in the specification. The DCS panel along with OWS, EWS, printer (in BHEL scope) shall be located in Control Room in Regeneration area. DCS based Remote I/O panel (in BHEL scope) shall be provided in the service vessel area.
2. The Contractor shall provide complete Instrumentation for control, monitoring and operation of entire CPU. The requirements given are to be read in conjunction with detailed Technical specification enclosed in the specification. Further, in case of any discrepancy in the requirement within the same section noted by the bidder in the specification, the same will be brought to the notice of BHEL in the form of pre- bid clarification. In absence of any pre-bid clarification, the more stringent requirement as per interpretation of customer shall prevail without any commercial implication.
3. The instrumentation to be provided for CPU shall be as per the technical specification document/ drawings wherever provided for the respective systems as a minimum requirement for bidding purpose. However, for completeness of the system and its associated equipment, Bidder shall also provide all the necessary instruments to the process requirement even if not indicated in the given technical Specification document /drawings. During detail engineering if any additional instruments are required for safe & reliable operation of plant, bidder shall supply the same without any technical, commercial and delivery implication to BHEL.
4. The make/model of various instruments/items/systems shall be subject to approval of owner/purchaser during detailed engineering stage. No commercial and delivery implication in this regard shall be acceptable. In case of any conflict and repetition of clauses in the specification, the more stringent requirements among them are to be complied with.
5. Components of instruments, control devices, accessories, piping etc. which contact steam, condensate or boiler feed water shall be manufactured from copper-free materials.
6. All the instruments/ drives shall be terminated on JB's/Panels in field. JB's/Panels shall be in Bidder's scope. Number of Junction Boxes shall be sufficient and positioned in the field to minimize local cabling (max 12-15 meters) and trunk cable.
7. For cable scope, refer to electrical scope between BHEL and vendor defined in electrical specification.
8. Bidder to provide mandatory spares as per mandatory spares list.
9. Electrical Actuators with integral starter shall be provided for all on/off and inching type valves along with necessary interface units for linking to corresponding Control System as applicable, typical Hook-up diagram of drives is included for reference. Non-contact type electronic 2-wire position transmitters shall be provided for all inching type motorized valves. The detailed specification is enclosed elsewhere in the specification.
10. All regulating duty control valves shall be equipped with smart positioner having integral IP Converter and valve position transmitter.
11. The specifications for instruments mentioned in the specification are minimum requirements. The detail specifications shall be finalized during detail engineering.
12. The bidders shall specifically mention any deviation they would like to take on the C&I specification. In absence of only deviation, a No deviation certificate is to be furnished.
13. Bidder to terminate all instrumentation and control elements in junction boxes. Bidder to provide input/output list, drives list, junction box schedule and termination details, recommended control logics / write-up etc. the list of documents to be submitted after award of contract is to be referred by bidder.
14. All local gauges, transmitters and switches shall be mounted on suitable enclosures, racks subject to owner's approval. All transmitters shall be HART compatible.
15. Bidder to perform tests of C&I items/instruments/systems as per Quality plans/ type test attached in the specification. However, if any test not specified in the quality plan but specified in specification Tests for I&C equipment included elsewhere in specification will have to perform by Bidder without any cost implication. The

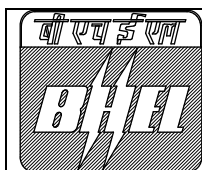

<b>TITLE:</b> <b>1 X 660 MW SAGARDIGHI TPS UNIT NO.5 PHASE III</b>	SPECIFICATION NO. PE-TS-445-155A-A001	
	SECTION : I	
<b>TECHNICAL SPECIFICATION FOR CONDENSATE POLISHING UNIT</b>	<b>SUB-SECTION: IC</b>	
	REV. NO. 02	DATE : 18.04.2022

make/model of various instruments/items/systems shall be as per Customer/BHEL approved vendor list. No commercial and delivery implication in this regard shall be acceptable. In case of any conflict and repetition of clauses in the specification, the more stringent requirements among them are to be complied with.

16. Instrument installation and accessories required for the same shall be in Bidder's scope and shall be submitted after award of contract. However, any instrument/ analyzer installation not covered in the same shall be subject to customer and BHEL approval during detailed engineering.
17. RTD's shall be of duplex type. Both the elements of duplex temperature sensors shall be terminated to junction boxes. Temperature measurement shall have upscale / down scale drive to protect from process upset in case of sensor failure. For RTDs ring - tong type lugs shall be used at Junction Boxes.
18. Bidder to provide JB/ Rack & other erection hardware.
19. Instrument racks for mounting pressure and flow transmitters, pressure switches, conductivity analyzers, etc. for each of Condensate Polisher Mixed Beds. Analyzers and pressure transmitters shall be mounted in separate racks. The type of rack (Open or Closed type) shall be selected in line with specification.
20. Bidder to furnish electrical load/UPS load data during detailed engineering.
21. UPS Power supply shall be provided by BHEL at a single point, further distribution to various instruments/equipment of the system shall be in bidder scope. Bidder to include necessary power distribution board in his scope. Any power supply other than the above, if required by any instrument/equipment has to be derived by the bidder from the above supply & all necessary hardware for the same shall be in bidder scope. Bidder to submit the power requirement along with the bid.
22. Bidder's presence is required for 3 Man days (Excluding travel time) at EDN Bangalore during FAT of DDCMIS for certifying correctness & completeness of implementation of Control logic. Intimation to attained FAT shall be informed in 2 days advance. All the expenses like boarding, lodging and travel, Air fare etc. shall be in bidder's scope.
23. Contractor's C&I representative shall be present at BHEL-PEM for 3 man-days, for preparation of Control scheme of CPU. All the expenses like boarding, lodging and travel, Air fare etc. shall be in bidder's scope.
24. Bidder's presence is required for 15 Man days (in three visit) at site during commissioning of DDCMIS for assistance related to process correctness. Three visit with total 15 Man days (Excluding travel time) in which one visit shall be of 5 Man days each. All the expenses like boarding, lodging and travel, Air fare etc. shall be in bidder's scope.
25. Contractor shall furnish Instrument Schedule, I/O list, Drive list, Cable Schedule, Cable interconnection (DCS end terminal details shall be provided to vendor during detail engineering to incorporate in cable interconnection), JB grouping, Annunciation list, SOE list, List of Instruments/devices for HART in BHEL approved format. Also, reusable database format like MS Excel, MS Access etc. of these documents shall also be provided by Contractor in BHEL approved format. Soft copy of the formats shall be provided to the successful bidder.
26. Interface of MCC, HT SWGR, Solenoid valves, field instruments, Actuators etc. with DDCMIS based control system shall be as per Drive Control Philosophy enclosed in specification.
27. 27. Local control panel, if any required for operation shall be in bidder scope.
28. The solenoid operated valves/ dampers/gate shall have a limit switch for open/ close feedback. Solenoid Valve shall be rated for 24V DC only.
29. Interface of MCC, HT SWGR, Actuators, solenoid drives, control valves etc. with DCS based control system shall be as per Drive Control Philosophy attached in the specification.

	<b>TITLE:</b>	SPECIFICATION NO. PE-TS-445-155A-A001	
	<b>1 X 660 MW SAGARDIGHI TPS UNIT NO.5 PHASE III</b>	SECTION : I	
	<b>TECHNICAL SPECIFICATION FOR CONDENSATE POLISHING UNIT</b>	<b>SUB-SECTION: IC</b>	
		REV. NO. 02	DATE : 18.04.2022

30. All field instruments enclosure shall be IP65. Local panel/ cabinet enclosure shall be IP 55, unless otherwise specified. Electronics located outside control room shall be tropicalized and enclosed in dust & weatherproof cabinets (IP-65 / 67) suitable for the environment.
31. Diaphragm seal shall be provided with Instruments having contact with corrosive media.
32. Primary sensor redundancy for Control/ measurement shall be decided as per following general criteria:
- Critical controls & respective measurements, measurements required for protection of auxiliaries & for major CLCS- Triple redundant.
  - Non-critical but important control & measurements and measurements required for other CLCS- Dual redundant.
33. Double root valve shall be provided for all pressure tapings where the line pressure is 40kg/cm<sup>2</sup> and above. Single root valve for below 40Kg /sq. cm.
34. Use of process actuated shall be avoided unless unavoidable.
35. Number of pairs to be selected for Screen /Control cable
- F-Type: 2P/4P/8P/12P (Size: 0.5sqmm<sup>2</sup>)
  - G-Type: 2P/4P/8P/12P (Size: 0.5sqmm<sup>2</sup>)
  - c) Core Cable: 3CX2.5sqmm<sup>2</sup>/ 5CX2.5sqmm<sup>2</sup>/ 12CX1.5sqmm<sup>2</sup>
36. Instrument installation shall be as per the attached "Standard Hook-up diagram of instrument.
37. In addition to requirements specified here, all C&I systems/ sub-systems/ equipment/ devices shall also meet other requirements stipulated under other Sub-sections/ parts/ sections of specification.
38. In case of any conflict and repetition of clauses in the specification, BHEL discretion will prevail.
39. All the outdoor field instruments such as analyzers/ transmitters/ meters etc. shall be provided with suitable Free standing cabinet(s)/panel/rack so that the equipment are protected against rain/ sunlight etc. Site fabricated racks are not accepted.
40. Control & Instrumentation equipment shall be guaranteed against manufacturing defect for at least two (2) years from the date of handing over to Owner.



**TITLE:**  
**1 X 660 MW SAGARDIGHI TPS UNIT NO. 5**  
**PHASE III**

SPECIFICATION NO. PE-TS-445-155A-A001

SECTION : II

**TECHNICAL SPECIFICATION FOR**  
**CONDENSATE POLISHING UNIT**

**SUB-SECTION:**

**REV. NO. 02**

**DATE : 18.04.2022**

**SECTION – II**

**GENERAL TECHNICAL REQUIREMENTS**

- SUB-SECTION – IIA:** General Technical Requirements (Mech.)
- SUB-SECTION – IIB:** General Technical Requirements (Electrical)
- SUB-SECTION – IIC:** General Technical Requirements (C&I)



**TITLE:**  
**1 X 660 MW SAGARDIGHI TPS UNIT NO. 5**  
**PHASE III**

SPECIFICATION NO. PE-TS-445-155A-A001

SECTION : II

**TECHNICAL SPECIFICATION FOR**  
**CONDENSATE POLISHING UNIT**

**SUB-SECTION: IIA**

**REV. NO. 02**

**DATE : 18.04.2022**

**SECTION – II**

**SUB-SECTION IIA: GENERAL TECHNICAL REQUIREMENTS (MECH.)**

**WBPDCCL**

**EPC Bid Document**  
**Sagardighi Thermal Power Project**  
**1x660 MW Unit No. 5, Phase - III**

## SECTION-I

### POWER CYCLE PIPING VALVES AND SPECIALTIES

#### 1.00.00 **GENERAL INFORMATION**

1.01.00 This section covers all the piping, valves and specialties which connects the different equipment like the boiler, turbine, condenser, pumps, heaters etc. to make the power cycle complete.

#### 2.00.00 **PERFORMANCE REQUIREMENT**

The piping system acts as the pressure boundary for the fluid in circulation; water and steam in this case, which is subject to high pressure, temperature, change of phase and various types of transient and steady state operation. The piping system shall be designed and constructed for integrity, long life, high reliability acceptable pressure drop, smooth and good operation and control from start-up to the maximum sustained load.

#### 3.00.00 **CODES & STANDARDS**

3.01.00 The design, manufacture, inspection and testing of the equipment covered under this specification shall conform, in general, to the standards and codes (latest edition) mentioned below :

- |         |   |   |   |
|---------|---|---|---|
| 3.01.01 | ANSI B-31.1   | : | Code for Pressure Piping - "Power Piping".      |
| 3.01.02 | Indian Boiler Regulations   | : | (IBR), with latest amendment.                   |
| 3.01.03 | ANSI B-16.5   | : | "Steel pipe flanges and flanged fittings".      |
| 3.01.04 | ANSI B-16.9   | : | Wrought steel Butt welding fittings.            |
| 3.01.05 | ANSI B-16.10  | : | Face to face & end to end dimensions of valves  |
| 3.01.06 | ANSI B-16.11  | : | "Socket Welding Ends".                          |
| 3.01.07 | ANSI B-16.25  | : | "Butt Welding Ends".                            |
| 3.01.08 | ANSI B-16.34  | : | "Steel Valves - Flanged and Butt Welding Ends". |
| 3.01.09 | ASME B-36-10  | : | Welded & Seamless Wrought steel Pipe            |
| 3.01.10 | ANSI/ASME B 36-19   | : | Stainless Steel Pipe                            |
| 3.01.11 | Design fabrication, assembly and testing of pipes, fittings shall generally conform to the requirements of ANSI B-31.1. Additionally components, which come under the purview of Indian Boiler Regulations (IBR), shall completely comply the requirements of IBR as a minimum. |   |   |



**WBPDCCL**

**EPC Bid Document**  
**Sagardighi Thermal Power Project**  
**1x660 MW Unit No. 5, Phase - III**

3.01.12 Any other internationally accepted codes and standards are also acceptable. However, the compliance of ANSI codes and IBR will be considered as minimum for acceptance of the piping and all appurtenances.

#### **4.00.00 SCOPE OF WORK**

##### **4.01.00 Scope of Supply**

Scope shall include all piping, valves & specialties as indicated in Annexure-I of this section. Items not mentioned but deemed necessary by the Bidder for making the system complete, reliable and efficient shall also be included.

4.01.01 The equipment and materials to be supplied under this specification shall include but not be limited to the following :

- a) Supply of all power cycle piping including bends, elbows, tees, branches, laterals, crosses, reducing union, couplings, caps, saddles, shoes, flanges, blank flanges, Y-pieces etc. as required for the piping system under the scope of this specification.
- b) Matching pipes, matching pieces like reducers/expanders etc., counter flanges with bolts, nuts, washers, temporary and permanent gaskets, threaded union etc. for all terminal points as required.
- c) Supply and machining work of flanges, pipe spools and matching pipes to connect flow measuring orifices/nozzles with the main pipe work. The pipe spools shall be supplied along with necessary test certificates of the pipes, after necessary machining to the required bore, for assembly of flow nozzle element. The assembled flow nozzle shall be installed in the piping system. Additional length of pipes equal to length of all fully assembled flow nozzle & orifice plates pipe piece shall be supplied and the same shall also be erected prior to cleaning of the pipes by flushing or steam blowing or chemical cleaning or both. After completion of cleaning of piping the assembled flow nozzles shall be erected replacing the temporary pipe spools.
- d) All motorised valves, control valves, manually operated isolating and regulating valves, non-return valves, steam traps, relief/safety valves, strainers, pressure reducing orifices, expansion joints and other flexible connections, complete with the counter flanges and matching connecting pieces as required within the terminal points of entire power cycle piping system.
- e) Anchors, hangers and supports, vibration dampeners, restraints, shock absorbers etc. as required. Any platform necessary for maintenance and operation of valve and equipment located 1.5 m above any permanent floor including access ladders, supporting structures etc.
- f) All secondary structural steel members required for pipe supports from building steel structures and from embedded steel including pipe supports in trenches.



**WBPDCCL**

**EPC Bid Document  
Sagardighi Thermal Power Project  
1x660 MW Unit No. 5, Phase - III**

- g) Funnels, tundishes for drips and drains including all miscellaneous drain piping and drain piping from tundish outlet up to drain points. All drain and vent lines shall be conveniently terminated either in Blowdown tank/flash tanks or permanent drain trenches of the Power Station.

All steam and saturated water open drains shall be drained through a water seal in drain funnels/tundish with a water connection in funnels/tundish for maintaining water seal level in them.

All oily effluent drains should be separately routed and connected to separate pit.

- h) For the isolation and check valves located on the main steam, hot reheat, cold reheat L.P. bypass and extraction lines, suitable line drains shall be provided just upstream and downstream of each of these valves. No drain is needed at the downstream of L.P. bypass isolation valve. Each of these drains shall be independently led to the condenser with branching off to atmosphere.

Line drains from MS, HR, CR, L.P. bypass & high pressure (above 40 Kg/Sq.Cm.) extraction lines shall be provided with double isolation valves in series for each branch - each located at the two extreme ties of the line drain route. The valve near the condenser should be motorised one. The balance line drains shall be provided with only one isolation valve for each branch.

- i) Bolts, nuts, washers, temporary and permanent gaskets, fasteners as required for interconnecting piping, valves & fittings as well as for terminal points.
- j) Complete insulation material for piping, valves, specialties & auxiliary equipment specified in this specification and as called for in the specification for thermal insulation.
- k) Painting of all piping, valves & specialties at site.

4.01.02 Bidder shall furnish his own layout and technical details of piping, valves, specialties and accessories along with his offer.

Following general requirements shall however be provided :

a) **Instrument Connections**

The following instrument tappings shall be provided :

i) **Pressure Tappings**

The Contractor shall furnish stubs and root valves for all gauge, transmitter and pressure test connections as required. The number of root valve for each connection shall be two (2) for system design pressure equal to or greater than 40 Kg/Sq.cm.g.





**WBPDCCL**

**EPC Bid Document  
Sagardighi Thermal Power Project  
1x660 MW Unit No. 5, Phase - III**

ii) **Temperature Tappings**

The Contractor shall supply all stubs and mount the thermowells.

iii) **Flow Measurement Tappings**

The Contractor shall provide stubs and root valves similar to the above for all differential pressure taps at flow nozzle and orifice plate installations.

- b) Pipe stubs and blanking plates required for chemical cleaning and hydro testing.
- c) Flanges, spool pieces, gaskets, ring joints, jointing materials, aluminium and stainless steel forged marking plate and temporary piping for steam blowing.
- d) Drain/drip pockets on steam piping as per stipulation of ASME, TDP - Vol.-I and general requirement.
- e) Expansion marker for high temperature steam lines.
- f) Fine threaded Radiography holes with stubs and suitable matching plugs, which shall be finally seal welded for piping, more than 25 mm nominal thickness.

For conducting performance test of Turbo-Generator and Boiler, the required pressure, temperature, flow measurement points shall be provided.

- g) Provision for creep measurement on the piping operating in creep region viz. main steam and hot reheat.

4.01.03 Electrodes and filler wires required for stainless steel and alloy steel welding during shop fabrication at works and erection/installation at site.

4.01.04 All temporary pipes and accessories, supporting arrangement for cleaning, flushing and steam blowing of the main steam, cold reheat and hot reheat piping including HP/LP by pass piping and auxiliary steam piping.

4.02.00 **Scope of Services**

4.02.01 The Contractor shall design the piping system and perform necessary stress analysis of all piping as necessary.

Besides the flexibility analysis, steam hammer analysis / dynamic analysis shall also to be performed wherever required to study the effects of fast closure of steam admission valves and safety valve blowing. Requirements of additional restraints / snubbers to take care of these effects shall be established, and the contractor shall provide such restraints / snubbers. The Contractors shall also analyze the effects of seismic and wind loads and



**WBPDCCL**

**EPC Bid Document  
Sagardighi Thermal Power Project  
1x660 MW Unit No. 5, Phase - III**

provide adequate support to take care of the same.

- 4.02.02 For stress analysis purpose, individual piping systems shall be considered up to the anchor points (location to be decided during detail engineering). All anchors coming within the piping are to be designed, supplied and erected by the Contractor.
- 4.02.03 Stress analysis and hanger selection for all piping specified else where, including piping attachment for hangers/supports, all auxiliary supporting structures are included in the scope of the Contractor.
- 4.02.04 The Contractor shall submit the design calculations for pipe sizing, thickness with specified diametres of pipes and stress analysis data to Owner/Consultant for review/reference/records. Pressure drop calculation for main steam, cold reheat and hot reheat piping to be submitted by the Contractor to show the adequacy pipe sizes to meet steam parameter at turbine inlet.
- 4.02.05 Preparation of detailed fabrication drawings (isometric) of shop fabricated piping which are of size 50 NB and above should be based on the "Released for Construction" drawings pertaining to power cycle piping layout prepared by the Contractor.
- "As built" drawings of the power cycle piping layout shall also be prepared by the Contractor based on any layout modifications made at site over "Released For Construction Drawings".
- 4.02.06 The Contractor shall design and detail all piping supports including restraints, guides, stops, snubbers, dampers etc. based on the final stress analysis and hanger load data. The Contractor's design of all supports shall be submitted to the Owner for review.
- 4.02.07 The Contractor shall furnish separate sketches for each support, restraint, anchor, snubber, dampers etc. These sketches shall include the location with reference to column co-ordinates, identification number, bill of material, design loads, operating load, spring stiffness, amount of spring pre-compression, etc. and method of attachment to the pipe and steel structure.
- 4.02.08 In order to ensure that all piping, supporting elements, anchors and restraints have been installed and adjusted in accordance with the drawings and other written instructions of the Contractor, the hangers associated with the main steam, hot reheat, cold reheat, HP & LP by-pass, feed water, auxiliary steam piping etc. shall be inspected as follows :
- a) After hydro test, with the piping in the cold position, with all travel stops removed, with the pipe completely insulated and in all respects ready for start-up.
  - b) Piping in the hot position, with the unit operating at maximum load.



**WBPDCCL**

**EPC Bid Document  
Sagardighi Thermal Power Project  
1x660 MW Unit No. 5, Phase - III**

- c) Piping in the hot position after 6 months of operation.
- d) Piping in the cold position during first complete shutdown after at least 6 months of operation.

The contractor shall depute his personnel for this purpose to site if the plant is officially handed over to the owner before such inspection after 6 months of operation.

- 4.02.09 At the time of each inspection, the Contractor shall determine the necessity for revision, adjustment or replacement of pipe supporting elements, restraints and anchors. Any changes proposed shall be incorporated by the Contractor after Owner/Consultant's concurrence.
- 4.02.10 All shop tests satisfying the requirements of Indian Boiler Regulations (IBR), ANSI standards, the standards enumerated herein and/or as specified.
- 4.02.11 Furnishing drawings, data, design calculations, stress analysis results.
- 4.02.12 Furnishing certified copies of test results for all tests and examinations specified in the specification and for the mandatory tests and analysis required by the ASTM material specification, for the materials used for piping and the pressure parts of the valves.
- 4.02.13 Obtaining approval from Chief Inspector of Boilers as per Indian Boiler Act, including the following :
- a) For all pipelines coming under the purview of Indian Boiler Regulations (IBR) necessary approval of the design and layout drawings shall be obtained from the Chief Inspector of Boilers, and furnished to the Owner/Consultant. Necessary certificates of design, manufacture and tests in specified Form of IBR, for each fabricated pipe with proper identification shall be submitted.
  - b) For fittings and specialties, viz. valves, flanges, traps and other specialties, etc. of all pipelines coming under the purview of IBR, Certificate of design, manufacture and tests in specified Form of IBR with appropriate identification shall be furnished to the Owner/Consultant.
  - c) Erection & testing of the pipe lines coming under the purview of IBR shall meet all the requirements of IBR and certificate of manufacture & tests in specified Form of IBR, for each of the erected pipe lines shall be submitted to the Owner/Consultant prior to the application of insulation and/or flushing the line before commissioning.
  - d) Steam blowing or chemical cleaning of piping systems, as specified elsewhere in the specification, after complete erection is to be carried out, which also includes supply, erection and dismantling of temporary piping, valves and fittings.
- 4.03.00 Omission of specific reference to any item or material or work which is necessary for completion of the piping systems, shall not relieve the bidder of





**WBPDC**

**EPC Bid Document  
Sagardighi Thermal Power Project  
1x660 MW Unit No. 5, Phase - III**

the responsibility of furnishing all material and services for a complete installation satisfying the operational and other requirements stated in the specifications.

4.04.00

Drawing indicating the layout of pipe work shall be prepared in line with the flow diagrams and shall be provided as part of the Contract. These drawings shall indicate the position of all supports, guides, restraints and anchors; all drain and vent connections and the position of all pipes. All piping systems shall be arranged to allow adequate falls in the direction of flow, except where otherwise approved by the Owner. At the points of drainage, drain pockets of ample size and approved construction shall be fitted as per details indicated in the enclosed drawings.





WBPDCCL

EPC Bid Document  
Sagardighi Thermal Power Project  
1x660 MW Unit No. 5, Phase - III

5.00.00 **SPECIFIC DESIGN CRITERIA**

SL.NO.	ITEM	CRITERIA
1.00	<b>Design, fabrication &amp; Erection</b>	
1.01	Design, fabrication, testing & erection of Power Cycle Piping, valves & specialties for critical piping system under purview of IBR, as specified.	To satisfy IBR, ANSI/ ASME B31.1 latest code.
1.02	Design, fabrication, testing & erection of Power cycle piping, valves & specialties for non-critical piping system, which are not purview of IBR, as specified.	To satisfy ANSI/ASME B31.1 latest code.
1.03	Design of safety valve installation.	To conform with the Non-mandatory rules for the design of safety valve installation of ANSI/ASME B31.1.  Open discharge installation preferred.
2.00	<b>Piping flexibility Analysis</b>	
2.01	Piping to be analysed	All piping having sizes equal to or above 50 mm NB & design temperature 100°C and more.
2.02	Code to be followed	ANSI/ASME B31.1 latest & also satisfying IBR latest amendments.
2.03	<b>Loading conditions to be considered</b>  Note: Contractor shall justify with reasoning in case any one of the specified loads is not considered in analysis.	<ul style="list-style-type: none"> <li>a) Internal pressure.</li> <li>b) Thermal loads due : <ul style="list-style-type: none"> <li>i) Piping thermal expansion.</li> <li>ii) Anchor displacement due to thermal movements of piping anchors.</li> </ul> </li> <li>c) Piping weight consisting of weight of piping, valves, bends, fittings, insulation etc. as well as weight of support components like clamps, shoes, suspension rods, trapeze etc. &amp; weight of contained fluid.</li> </ul>





WBPDCCL

**EPC Bid Document**  
**Sagardighi Thermal Power Project**  
**1x660 MW Unit No. 5, Phase - III**

SL.NO.	ITEM	CRITERIA
2.04	<p><b>Loading Combinations</b></p> <p>Note : Contractor shall clearly indicate the basis of his judicious selection or loading combination for support, restraints and anchor design.</p>	<p>d) Test or cleaning fluid load.</p> <p>e) Equivalent static loads due to discharge of Safety Valve (SV), Electromatic Relief Valve (ERV), simultaneous discharge of SV &amp; ERV where applicable.</p> <p>f) Dynamic load due to steam hammer (if applicable).</p> <p>g) Seismic loads due :</p> <p style="padding-left: 20px;">i) Equivalent static load due to seismic inertia effect.</p> <p style="padding-left: 20px;">ii) Equivalent static load due to seismic anchor displacement.</p> <p>h) Wind load where applicable.</p> <p>Design load for supports, restraints, anchors &amp; supporting structures shall be obtained by proper selection of one or combination of two or more of the loads as per item 2.03 above based on the possibility of independent or simultaneous occurrence.</p> <p>Component of thermal expansion reaction range expected to appear at cold condition, as per Equation 9 &amp; 10 of ANSI/ ASME B31.1 shall be considered in loading combinations.</p> <p>An overload factor of 1.30 shall be considered over the computed loads except occasional loads before combining them.</p>
2.05	<p><b>Combination of Stresses</b></p>	<p>The computed stress under different loading conditions shall be combined as per Equation 11, 12 &amp; 13 of ANSI/ASME B31.1 &amp; the stress shall be within allowable limits.</p>





WBPDCCL

**EPC Bid Document**  
**Sagardighi Thermal Power Project**  
**1x660 MW Unit No. 5, Phase - III**

SL.NO.	ITEM	CRITERIA
2.06	<b>Allowable Stress Values</b>	For piping materials other than ASME/ASTM materials, values shall be derived as per the criteria defined in Appendix-P of ASME Boiler & Pressure Vessel Code, Section-VIII, Division 1 while computing pipe wall thickness, and flexibility analysis shall be conducted as per ANSI/ASME B31.1. However higher pipe wall thickness derived between IBR regulation & ANSI/ASME B31.1 code shall be considered.
2.07	<b>Factor to be considered in flexibility analysis</b>	<p>a) Contractor shall consider value of stress range reduction factor "f" for cyclic conditions due to temperature reversals equal to ONE.</p> <p>b) Stress intensification factors at all transitions, fittings &amp; all branches as per ANSI/ASME B31.1.</p> <p>c) Variation in supporting effort by variable spring due to pipe movements.</p>
2.08	<b>Piping layout</b>	Flexibility analysis of Piping is to be conducted as per the offered piping layout. In case any modification of piping layout is felt essential to maintain stresses & terminal reactions within allowable ranges, same are to be carried out by the Contractor after discussion with Owner.
3.00	<b>Design Pressure &amp; Temperature</b>	As per IBR. Wherever not clearly stipulated in IBR, criteria stipulated in ASME/ ANSI 31.1 for selecting design pressure & temperature shall be followed.
4.00	<b>Material of construction of piping, valves &amp; specialties</b>	ASME/ASTM materials



**WBPDC**

**EPC Bid Document**  
**Sagardighi Thermal Power Project**  
**1x660 MW Unit No. 5, Phase - III**

SL.NO.	ITEM	CRITERIA
5.00	<b>Hangers, supports etc.</b>	
5.01	Type	<p>a) Variable spring :</p> <p>i) Where the variation in supporting effort between hot and cold condition does not exceed 20% of the load, which is higher of the operating condition, and cold setting load.</p> <p>ii) The resulting effect of load take-up/release by a group of hangers in a span does not overstress the piping span or cause overloading at equipment terminals.</p> <p>iii) Thermal deflection between hot &amp; cold conditions does not exceed 40 mm.</p> <p>b) Constant load - For thermal deflection between hot and cold conditions exceeding 40 mm and or, for above variation beyond 20%.</p> <p>c) Spring hangers should not be loaded more than 80% of the spring travel range.</p> <p>d) Rigid hangers &amp; restraints - To be judiciously selected, without exceeding the stipulated limits of terminal forces &amp; moments &amp; stress level. Struts shall be considered where compressive load is expected.</p> <p>e) Snubbers, dampers etc. - To take seismic/dynamic loads, thrust due to safety valve discharge. Effort shall be made to limit its use by judicious placement of rigid hangers.</p> <p>f) Bottom support spring hangers to be avoided as far as possible.</p>
5.02	Design, materials, fabrication testing and erection of hangers, supports, anchors, guides etc.	a) As per ANSI/ASME B31.1 latest code.



**WBPDCCL**

**EPC Bid Document**  
**Sagardighi Thermal Power Project**  
**1x660 MW Unit No. 5, Phase - III**

SL.NO.	ITEM	CRITERIA
		b) Hanger suspension rods, tie-rods/struts should have proper arrangement & adequate length, so that thermal movements in direction which are free are not constrained and should not make an angle more than 4 degrees with vertical due to horizontal pipe movements.

**Note :** Steam hammer analysis of the main steam & HP/LP By-pass pipe line on stop valve closing shall be carried out.

## 6.00.00 DESIGN AND CONSTRUCTION

### 6.01.00 General Considerations

6.01.01 Pipe sizing and piping system design shall conform to the requirements of power piping code ANSI B31.1. Statutory requirements as laid down in Indian Boiler Regulations (latest edition) will also be taken care in pipe system designs. Pipe wall thickness as calculated by ANSI Code formula will also be checked for IBR requirements for piping systems falling under the purview of IBR. Pipe corrosion allowance of 1.6mm shall be added to the minimum wall thickness.

6.01.02 Inside diameters of piping shall be calculated first for the flow requirement of various systems. The velocity limits for calculating the inside diameters are listed below :

- |    |  |                  |
|----|--|------------------|
| a) | Main Steam hot and cold reheat piping                              | 75 m/sec.        |
| b) | Auxiliary steam (Aux. steam to take care of various design flows). | 40 – 50 m/sec.   |
| c) | Feed Water   |                  |
|    | i) Suction   | 2.0 – 3.0 m/sec. |
|    | ii) Discharge  | 6.0 m/sec.       |
| d) | HP bypass  |                  |
|    | i) Upstream  | 75 m/sec.        |
|    | ii) Downstream   | 125 m/sec        |



**WBPDCCL**

**EPC Bid Document**  
**Sagardighi Thermal Power Project**  
**1x660 MW Unit No. 5, Phase - III**

- |    |                      |  |
|----|----------------------|--|
| e) | LP bypass            |  |
|    | i) Upstream          | 75 m/sec.                                |
|    | ii) Downstream       | 125 m/sec.                               |
| f) | Extraction steam     |  |
|    | i) Superheated steam | 60 m/sec.                                |
|    | ii) Saturated steam  | 30 m/sec.                                |
| g) | Condensate           |  |
|    | i) Discharge         | 5.0 m/sec.                               |
|    | ii) Suction          | 1.5 m/sec.                               |
| h) | Heater Drains:       | 1.5 m/sec.                               |
| i) | Heater Vents:        | 25 m/sec.                                |
| j) | Other piping         | As per good proven engineering practice. |

**NOTE:** This standard sets the maximum limits of the flow velocity.  
 Lower velocities may be selected if found necessary.  
 Any Deviation by the bidder shall be subject to Owner's approval.

Inside diameters thus calculated shall be checked for allowable pressure drop for various systems and the minimum pipe size meeting the pressure drop requirement is to be recommended. Pressure drop in main steam line shall not be more than 90% of the pressure differential between superheater outlet header and HP turbine inlet valves at BMCR. Similarly, combined pressure drop in cold and hot reheat piping will not exceed 90% of the available pressure differential between HP turbine exhaust and LP turbine inlet valves minus the reheater drop. The available pressure differential in the complete reheat line from HPT exhaust to IPT inlet shall not be more than 10% of the pressure at HPT exhaust. Wherever possible 5D/6D radius bends will be used to minimise the pressure drop in the main steam, cold & hot reheat piping systems.

Pipes shall be sized for the worst (i.e. maximum flow, temperature and pressure values) operating condition. In case of BFP suction pipe sizing "transient analysis" shall be carried out for optimum sizing of the system in order to establish the pipe inside dia for minimum pressure drop in system to match with the pump NPSH requirements under worst operating conditions. The Boiler Feed Discharge pipe-work shall be designed for the maximum final feed water temperature down-stream of H.P. heaters and the maximum closed valve pressure of the boiler feed pump in the following two cases, whichever gives a higher pressure.

- a) Temperature of water from deaerator = 15°C



**WBPDCCL**

**EPC Bid Document**  
**Sagardighi Thermal Power Project**  
**1x660 MW Unit No. 5, Phase - III**

- b) Deaerator storage tank working at its maximum possible pressure with saturated water.

The design pressure for BFP discharge piping shall be selected such that the minimum calculated thickness for various pipes at design temperature is sufficient for the following conditions, considering allowable stresses as per ASME B31.1

Discharge Pressure corresponding to Turbine driven BFP trip speed at shut off head flow condition, if TDBFP characteristics is governing for calculation of boiler feed discharge piping design pressure.

Discharge pressure corresponding to Motor driven BFP trip speed (frequency 51.5Hz) at shut off head flow condition, if MDBFP characteristics is governing for calculation of boiler feed discharge piping design pressure. However, Bidder may consider higher stress under occasional cases as per the provision of ASME B31.1 for which the requirement of special provision as per the stipulation of clause no. 520 of IBR shall be met as a must by the Bidder.

In addition to this the rest of the design basis shall be same as for other water services described above.

**6.01.03****Pipe wall Thickness**

Thickness calculation shall be made on the basis of procedure and formula given in ANSI/ASME B 31.1. Thickness thus calculated shall then be checked based on the procedure and formula given in IBR. Then, based on the higher value of the two calculations (after adding manufacturing tolerance), the next heavier commercial wall thickness shall then be selected from thickness schedules (e.g. Sch-40, Sch-80, etc) as contained in ANSI /ASME B36.10 for OD controlled pipes and from manufacture's schedules for ID controlled pipes. However, in such cases where the calculated thickness for OD controlled pipe falls beyond the thickness corresponding to the listed schedule nose as given in ANSI B36.10 for the pipe size, both ID and OD controlled pipes to manufacture's schedules are acceptable. OD controlled pipes shall be to the dimensional standards ANSI B36.10 for carbon & alloy steels pipes and ANSI B36.19 for stainless steel pipes. To Account for losses due to corrosion, erosion etc. during the plant service life, an allowance of 1.6 mm/0.75mm shall be added to the minimum wall thickness of pipes calculated as per ASME B31.1/IBR respectively. Further, the design pressure and temperature, down-stream of any pressure reducing valve upto and including the first block valve shall be the same as that at up-stream of pressure reducing valve. However, in no case, the selected pipe thickness shall be less than SCH XS for LP By Pass downstream piping and Sch.80 for alloy steel & carbon steel pipes of sizes 50 NB & below. . The selected thickness for SS pipes shall not be less than Sch-40 of ANSI B36.19. Further, for the piping systems likely to be subjected to two phase flow, i.e. downstream of control valves on heater drain lines etc., the selected thickness shall not be less than:- Sch-40 for pipe sizes above 50 NB, but below 300 NB and Sch-STD for pipe sizes 300 NB and above.



**WBPDCCL**

**EPC Bid Document**  
**Sagardighi Thermal Power Project**  
**1x660 MW Unit No. 5, Phase - III**

All design parameters shall be subject to Owner's approval.

- 6.01.04 No pipe work shall be run in trenches carrying electrical cables.
- 6.01.05 Pipes shall not be less than 20 mm bore unless authorised by the Owner/Consultant.
- 6.01.06 Site fabricated pipes shall be installed only where they do not exceed 50 mm bore and where their use has been approved in writing and shown on a scale drawing.
- 6.01.07 All piping shall be identified by means of colour strips and by adequate lettering, conveniently spaced and located. Identification colours and lettering shall be subject to approval by Owner.
- 6.01.08 Air release and drain branches shall be provided wherever necessary depending upon the layout and arranged so that the drains and air release valves are located for easy operation.
- 6.01.09 All valved drains in vacuum services shall be provided with screwed cap.
- 6.01.10 **IBR Piping Systems**

At Shop All piping including fabricated piping shall be hydro tested at 1.5 times the design pressure subject to regulation 374 of IBR. However, nondestructive testing in lieu of hydro test is also acceptable subject to regulation 343 (3) of IBR 2. After Erection All piping systems shall be hydro tested at 1.5 times the design pressure subject to regulation of 374 IBR. However, for such systems where it is practically not possible to do hydro tests, the tests as called for in ANSI B31.1 & IBR in lieu of hydro test shall also be acceptable.

**Note:**

- i) Material P91 or P92 is applicable for Main Stream, Hot reheat line, upstream of HP Bypass valve & upstream of LP Bypass valve.
- ii) EFW Pipes as per A 672 are acceptable if the design pressure and design temperature are such that it calls for 150 class piping and size is 550 NB and above. The fitting shall correspond to ASTM A 234.

6.01.11 **Layout**

- a) All high points in piping system shall be provided with vents and low points shall be provided with drains. Provisions of drains on steam piping shall be as per ASME code TDP-1.
- b) All drain and vent lines in piping system with design pressure 40 Kg/cm<sup>2</sup> (g) and above or with vacuum service shall be double valve.
- c) The pipe routing shall be such that a clear head room of not less than 2.5 meters above the walkways/working area is available. The Bidder



**WBPDCCL**

**EPC Bid Document  
Sagardighi Thermal Power Project  
1x660 MW Unit No. 5, Phase - III**

shall ensure correct orientation of and easy access to valves and instruments etc.

- d) Wherever there is possibility of ingress of rain water through floor/ceiling opening at points where any pipe passes through floor/ceiling suitable weather protection hood shall be provided.

All design parameters shall be subject to Owner's approval.

## 6.02.00 **Stress and Flexibility Analysis**

- 6.02.01 Overall procedure of stress & flexibility analysis shall be as per latest revision of ANSI B31.1/IBR and according to material used.

Flexibility and stress analysis for various piping systems shall be carried out by the Bidder as per the requirement of ASME B 31.1. Stress & flexibility analysis results shall satisfy the latest revision of ANSI B31.1 / IBR.

Calculated stresses in the piping system shall be within the allowable limits stipulated in ASME B 31.1 as well as in IBR for piping under the purview of IBR.

- 6.02.02 Complete and comprehensive stress and flexibility analysis of the piping shall be done by computer using an approved standard programme.
- 6.02.03 All piping of design temperature exceeding 100°C and nominal size equal to or above 50 mm except otherwise mentioned in Specific Design Criteria shall be stress analysed considering the effects stipulated therein.
- 6.02.04 The method of analysis due to seismic effects on static equivalent basis shall be submitted to Owner/Consultant for approval prior to start of the analysis.
- 6.02.05 Stresses in pipes and fittings due to the above effects shall be limited to level prescribed by IBR wherever applicable. Other stress criteria not prescribed by IBR shall be guided by ANSI B31.1. Stress intensification factors as per the appendix D of ASME B31.1 shall be taken. Suitable stress intensification factors shall be assumed. Allowable stresses shall be computed by methods prescribed by IBR wherever applicable. However, such allowable stresses shall not be more than those prescribed by the relevant codes/standards.
- 6.02.06 The results of stress analysis shall be submitted for approval by Owner/Consultant before start of Fabrication or Erection clearly confirming the following :
- a) The terminal forces and moments are within permissible limit.
  - b) Forces and moments on supports, anchors and restraints attached to building/supporting structures are within permissible limit.
  - c) Stresses on piping are within acceptable limit stipulated in the applicable codes.



**WBPDCCL**

**EPC Bid Document  
Sagardighi Thermal Power Project  
1x660 MW Unit No. 5, Phase - III**

- d) Pipe movements are acceptable for the spacing in between adjacent pipes and between pipes and adjacent structures/ equipment etc.
- e) Stress checking for occasional loading.
- f) All other stress/flexibility checking as stipulated in IBR/ American codes whichever is stringent.

Above stress analysis results shall be used for checking the piping design.

Calculated forces and moments on equipment nozzles/TP are not more than the allowable loading provided by respective equipment manufacturer(s)/Bidders. Flexibility analysis also calculates the deflections in all directions (translational and rotational) to enable design and selection of hanger/support system.

Besides the flexibility analysis, steam hammer analysis/dynamic analysis shall also to be performed wherever required to study the effects of fast closure of steam admission valves and safety valve blowing. Requirements of additional restraints/snubbers to take care of these effects shall be established and such restraints/snubbers shall be provided by the Bidder. The Bidders shall also analyse the effects of seismic & wind loads and provide adequate support to take care of the same.

Cold pulling is not permitted. The Bidder shall so design the piping systems that there will be no requirement of cold pull for meeting allowable reaction/stress values.

6.02.07 The finalised flexibility analysis in the form of a report indicating procedure of analysis, pipe sizing based on specified diameter, spring hanger summary, design load charts for Anchors. Restraints and hanger supporting structures delineating different loading conditions, stress charts, loading on terminal anchors, along with isometric drawings of pipings for flexibility analysis shall be submitted to Owner/Consultant for review.

6.02.08 All high temperature lines shall be provided with expansion markers with scales at certain hanger locations, as decided by the Owner/Consultant. The Contractor shall guarantee and prove during trial run, after a few cycles of operation that the range of thermal movements in three directions from cold to hot condition at the expansion marker locations are within  $\pm 20\%$  of the calculated values.

If the error exceeds the above limit, necessary adjustments and rectifications shall be carried out by the Contractor at no extra cost, till the above requirement is fulfilled.

6.03.00 **Material Specification**



**WBPDCCL**

**EPC Bid Document**  
**Sagardighi Thermal Power Project**  
**1x660 MW Unit No. 5, Phase - III**

- 6.03.01 Material for pipes and fittings shall be as stipulated in enclosed Annexure-II of this section. Bidder may note that ASTM materials have been considered for Main Steam, Hot reheat, Cold reheat, HP & LP bypass pipings and all the tendering information in the specification for such pipes have been given based on this material of piping. In case bidder wants to offer alternative piping material, same may be accepted by the Owner depending on the merits of alternative material. In that case pipe stress analysis, hanger selections etc. for such pipings are to be carried out by the Contractor accordingly.
- 6.03.02 Pipe attachments for supports, anchors and restraints, which are coming in direct contact with pipes and are inside the insulation of high temperature pipes shall have similar materials as the piping concerned. All other materials of supports, anchors and restraints shall be of tested quality and as per manufacturer's standards.
- 6.03.03 For rubber lined pipe, lining should be applied in three (3) layers, giving a total thickness not less than 4.5 mm.
- 6.04.00 **Fabrication**
- All power cycle piping above 50 NB shall have butt-welded connections as per ANSI B 16.25 with a minimum of flanged joints necessary for maintenance. Piping 50 NB and below 50 shall have socket welded connections as per ANSI B 16.11. All high-pressure steam valves and accessories shall have welded connections.
- Where flanges are adjacent to welded fittings, weld neck flanges shall be used.
- Branches shall, in general, be formed by welding. Standard fittings may be used in positions and for sizes where approvals have been given in detail drawings. Pipe bends and tees shall be truly cylindrical and of uniform section. All welded branches shall be reinforced where needed as per the applicable codes/ regulations.
- Unless otherwise specified, for all welded lines with pressure above 7 kg./sq. cm (g). and/or temperature above 200°C branch connections for branch sizes up to 25% of welded mains shall be made with special forged steel welded fittings.
- 6.04.01 The piping systems shall be constructed in accordance with the requirements of ANSI B31.1. The requirements of IBR 1950 (with latest amendments) shall be complied with for the piping systems, which are under the purview of IBR.
- 6.04.02 Piping shall be fabricated in the shop in the largest transportable sections to minimise the number of field weld joints. The choice of field weld joints locations shall be based on the traverse of the pipe through walls, floors, sleeves or other restrictive areas. Support attachments for major piping shall be done at shop.
- 6.04.03 All workmanship shall be carried out using methods and procedures of best recognised pipe fabrication practice and must be done in a good and



**WBPDC**

**EPC Bid Document  
Sagardighi Thermal Power Project  
1x660 MW Unit No. 5, Phase - III**

workman like manner in accordance with latest revisions of. ANSI standards, ASME Codes, PFI standards and IBR as applicable.

- 6.04.04 All high-pressure steam valves and accessories shall have welded connections.
- 6.04.05 Mitred bends and elbows will not be accepted unless otherwise specified. Only forged tees, 90 Deg. elbows and 45 Deg. elbows are acceptable. In case the Bidder wants to deviate from this requirement on account of non-availability of such forged items, he may submit his alternative offer for Owner's consideration with sufficient documents to justify the same. In such a case the concerned fittings shall be manufactured with necessary reinforcing pads, bend thinning allowance etc. to satisfy code requirements.
- 6.04.06 All pipes bends shall be made true to angle with no negative tolerance and shall have a smooth surface free of flat spots, crease and corrugations. A cross section through any bend portion of the pipe shall be true in diameter. All pipe bends shall have a radius of not less than 3 times the nominal pipe size unless otherwise mentioned. Pipe bends shall be made from straight pipe pieces of sufficiently higher thickness so that after thinning, the minimum thickness of bends shall not be less than the minimum thickness required for the straight pipe. Thinning allowance shall be considered as per ANSI B 31.1. The ends of pipe and welded fittings shall be bevelled according to details shown in the relevant piping codes.
- 6.04.07 All power cycle piping including hot small bore piping shall be stress analysed and shop fabricated.
- 6.04.08 All welding shall be made in such a manner that complete fusion and penetration are obtained without any excessive amount of filler metal beyond root area. The reinforcement shall be applied in such a manner that it shall have a smooth contour merging gradually with the surface of adjacent pipe and welded fittings. Backing rings shall not be used on any pipe welds, unless otherwise approved by the Owner/Consultant.

Pipe and attachments shall be properly aligned prior to welding. If tack welds are used the tacks shall be either fused into the first layer of weld or else chipped out.

All welding for steam and feed pipe work shall be electrical welding using the shielded arc process and electrodes in accordance with the relevant code. For pipes up to and including 100 mm. bore, provided the pipe does not exceed 12.7 mm. in thickness, gas welded butt joints will be accepted without backing rings.

Welded joints in pipe work shall be pre-heated to a temperature as required by the agreed standard or code or to the approval of the Owner/Consultant. The temperature shall be maintained during the welding operation and a record of metal temperature shall be obtained by means of a recording thermometer throughout the welding operation.

All welds shall be built-up by the application of multiple layers or passes. The thickness of metal applied for each layer or pass shall not exceed 3 mm.



**WBPDC**

**EPC Bid Document  
Sagardighi Thermal Power Project  
1x660 MW Unit No. 5, Phase - III**

Each layer shall be cleaned and lightly peened before the next layer is applied.

Before being assigned to welding work, each operator shall have passed a qualification test as prescribed in the applicable Code/ Regulations. Each approved welder shall have an identification number, which shall be indicated on all welds.

6.04.09 Welded joints shall be stress relieved as per ANSI B31.1./IBR. Stress relieving temperature shall be measured by thermocouple pyrometers or other suitable equipment. Readings of temperature against time shall be recorded.

6.05.00 **Welding**

6.05.01 **General**

Full-scale joints preparation sketches (to be included with the welding procedure) shall show all dimensions including tolerances for bevel angle, land size and off-set and root gap. Adequate copies of detailed welding procedure for approval of IBR shall be furnished.

6.05.02 **Cutting and Beveling**

- a) Carbon steel piping : End preparation for butt welding shall be done by machining/flame cutting.
- b) Chrom-Moly steel : End preparation for butt welding shall be done by machining.
- c) Socket welding : Socket weld end preparation shall be done by saw or machine cutting.

6.05.03 **Welding Electrodes and Rods**

All special welding electrodes and filler wires to be supplied and used for the work under this specification shall be of reputed make, approved/tested quality with valid test certificate and shall have proven performance record for similar application. Approval of the Owner as well as IBR should be sought in selection of the electrodes for specific uses.

The certificate of electrode shall incorporate all the chemical and physical test data and tests witnessed by a representative of the Inspecting Authority recognised under IBR.

6.06.00 **Hangers, Supports, Anchors and Restraints**

6.06.01 Hangers and supports shall be capable of carrying the sum of all concurrently acting loads.



**WBPDC**

**EPC Bid Document  
Sagardighi Thermal Power Project  
1x660 MW Unit No. 5, Phase - III**

- 6.06.02 All the hangers/supports shall be of reputed make, approved/tested quality and shall have proven performance record for similar application. They shall be designed to provide the required supporting efforts and allow piping movement with thermal changes without causing overstress. The design shall also prevent complete release of the piping load in the event of spring failure or misalignment and all parts of supporting equipment shall be fabricated and assembled so that they will not be disengaged due to movement of the supported piping. Necessary guides, anchors, braces and structural steel to be attached to building/boiler structure as well as any braces and/or dampeners required to eliminate piping vibration and seismic loading shall be provided.
- 6.06.03 In general piping shall be supported in such a manner to maintain drainage slopes, prevent interference with structure and piping and keep flexible supports in proper adjustment so that they will move within their design operating ranges. Normally pipe supports and anchors shall be selected at those points in the building where provision has been made for the loads imposed. The cutting of floor/roof beams or the reinforcement in slabs will not be permitted. Piping attached to a plant item shall be supported in such a way that the weight of the piping is not taken by the plant item.
- Support spacing shall be as per good engineering practice. However, in no case it shall be less than support spacing stipulated in ANSI B31.1.
- 6.06.04 The design of the pipe supports and hangers and their locations shall be guided by the following general principles :
- a) Criteria of loading shall be as per "Specific Design Criteria" enclosed.
  - b) Design loads for anchors, restraints, hanger supporting structures shall be as per the criteria stipulated in "Specific Design Criteria".
  - c) Supports shall be adequate for extra loading due to hydrostatic tests and when piping system is full of water during chemical cleaning.
  - d) Supports for relief valve stacks shall be adequate for both the pipe weight and the thrust developed due to safety valve discharge.
  - e) There should not be any interference of the hangers with other piping, pipe supports, cable trays structure, equipment etc.
  - f) Besides vibration elimination, hangers shall ensure that the amplitude of oscillations in the pipe work owing to shock and vibration due to variation of fluid flow from zero to full capacity remains within acceptable limits.
- 6.06.05 Attempts shall be made to use variable spring and rigid hangers as much as possible. Rigid hangers shall preferably be used where vertical movement of the pipe is negligible.



**WBPDC**

**EPC Bid Document  
Sagardighi Thermal Power Project  
1x660 MW Unit No. 5, Phase - III**

Variable spring supports/hangers may be used provided the following conditions are met.

- a) The variation in supporting effort between hot and cold condition does not exceed 20% of the load, which is higher of the operating condition, and cold setting load.
- b) The resulting effect of load take-up/release by a group of hangers in a span does not overstress the piping span or cause overloading at equipment terminals.
- c) Thermal deflection between hot and cold conditions does not exceed 40 mm.

Otherwise, constant load type support/hangers must be used. On the other hand rigid hangers can be used where possible without exceeding the stipulated limits of terminal forces and moments and the stress subject to the Owner/Consultant's approval.

An exception may be made in the instance where the piping movement occurs at a hanger supporting a portion of a piping riser on which rigid support is also located. In this case, variable spring hangers may be used for any amount of expansion up to the full recommended working range of the spring, provided the change in the supporting effect of the variable spring is added to the design load of the rigid support assembly. However, the acceptance of such a system will be at Owner/Consultant's discretion.

- 6.06.06 All design and fabrication including loading and allowable stresses shall be in accordance with ANSI B31.1. Note shall be taken of the requirements against earthquake at site. Hangers and supports for systems shall be completely engineered and prefabricated for all piping 50 mm. and above. Sufficient random materials shall be furnished for field support of all lines of smaller diameter.
- 6.06.07 For pipes of design temperature 100°C and more, bottom supports shall be avoided as far as possible and hanger type supports shall only be used. However, where bottom support cannot be avoided, the same shall be provided with suitable shoes along with balls/rollers/rockers to minimise frictional resistance against thermal movements. The material of shoe as well as the ball/rockers/rollers shall be suitable for the design temperature of the supported pipe and shall be of sufficient hardness so as to permit a reasonably long life keeping its roundness and maintaining a low friction factor. Where a constant load type support is required, the bottom support shall also be of constant load type.
- 6.06.08 Where stress analysis calculations are performed, the location of anchors, guides and restraints shall be based on the results of the final stress analysis. Such anchors, guides and restraints shall be designed for the maximum forces and moments encountered. Spring hangers shall be selected to allow the movements determined by the stress analysis.
- 6.06.09 The Contractor shall design and provide all supplementary steel required to properly secure and support all pipe supports, guided restraints, anchors,



**WBPDCCL**

**EPC Bid Document  
Sagardighi Thermal Power Project  
1x660 MW Unit No. 5, Phase - III**

shock absorbers, etc. furnished. Owner shall provide only the main steel work or, embedded plates in the concrete.

- 6.06.10 Accurate weight balance calculations shall be made to determine the required supporting force at each hanger location and the pipe weight load at each equipment connection.
- 6.06.11 Provision shall be made for support of piping, which may be disconnected during maintenance work
- 6.06.12 Supports shall be designed to prevent transfer of excessive loads from support to support or to equipment as the pipe expands or contracts. Support components shall be attached in places where they will not damage other construction either during or after installation. Cantilever type support shall not be taken from brick wall. Brackets may be used where piping is adjacent to vertical surfaces, suitable for support use, these shall be supported from columns/RCC structures.
- 6.06.13 All large pipes and all long pipes shall have at least two supports each arranged so that any length of pipe or valve may be removed without any additional supports being required.
- 6.06.14 Support steel shall be of structural quality. Perforated strap, wire or chain shall not be used. Support components shall be connected to support steel by welding, by bolting or by beam clamps. Bolt holes shall be drilled, not burned. Support components may be bolted to concrete using approved concrete anchors.
- 6.06.15 Double nuts or lock-nuts shall be used on hanger rods and bolts in all cases.
- 6.06.16 Variable springs shall be furnished with travel stops. The travel stops shall be factory installed at the "cold" position.
- 6.06.17 Spring hangers should not be loaded more than 80% of the spring travel range.
- 6.06.18 Both constant load and variable spring support/hanger shall be provided with outside indicators for deflection and load. Provision for the site adjustment of load at least  $\pm 10\%$  shall be incorporated. Also spring locking arrangement and turnbuckles of load/position adjustment shall be provided for all hangers.
- 6.06.19 Constant load type spring support/hangers shall be so selected as to permit, for the specific load, an over-travel of at least 25 mm or 20% (whichever is greater) of the specified range of vertical travel. The initial setting of the hangers/supports shall be such that half of the "over-travel" is allowed in either direction. Constant support hangers shall have a support variation of not more than 5% throughout the total travel range.
- 6.06.20 Rigid support shall be designed with adequate margins of safety so that variations in load distribution on them are of little consequence. All rigid hangers shall be provided with means for vertical adjustment after erection.



**WBPDCCL**

**EPC Bid Document**  
**Sagardighi Thermal Power Project**  
**1x660 MW Unit No. 5, Phase - III**

6.06.21 Where the piping system is subject to shock loads, such as thrust imposed by the actuation of safety valves (SV), hanger design shall include provision for shock absorbing devices of approved design.

Vertical restraints near safety valves shall be preferred for taking SV discharge thrust, provided equipment terminal reactions remains within allowable limit.

Attempts shall be made to avoid use of shock absorbers, dampers etc. as far as possible to take care of occasional loading like seismic effect etc. by proper engineering of the piping design and effective use of restraints. However, shock absorbers, VISCO-dampers, wherever felt necessary are to be supplied and erected by the Contractor.

6.06.22 Layout of piping shall be properly designed to avoid excessive vibration by effective use of restraints. However, wherever felt necessary, shock absorbers, VISCO-dampers shall be supplied and erected by the Contractor.

6.06.23 Hanger rods (except Rigid hangers where both tension and compression may occur) shall be subjected to tensile loading only. At hanger locations where lateral movement is anticipated, suitable linkage and rocking washers shall be provided to permit swing.

6.06.24 For all hangers, the length of suspension shall be so selected that the hanger rod may never make an angle of more than 4 Deg. with vertical due to horizontal pipe movements. If this cannot be avoided by erecting the hanger vertically for cold condition, it shall be suitably off set so that the above requirement is fulfilled in cold as well as hot conditions. Hangers shall be designed so that they cannot become disengaged by movements of the supported pipe.

6.06.25 Supports, guides and anchors shall be so designed that excess heat will not be transmitted to the building steel.

6.06.26 Tie rods/struts shall preferably be used for restraints to achieve low friction restraining.

The Tie-rods/struts shall have proper arrangement and adequate length, so that, thermal movements in other directions, which are intended to be free are not constrained and there is no appreciable shift in centreline of pipe or the elevation of the supporting point on pipe due to sway. The design shall have provisions for adjusting the length to take up any slack and securely locking in position permanently once adjustment is done.

6.06.27 All relevant hangers shall be designed to take the dynamic movements for dynamic loading in addition to the thermal movements.

6.07.00 **Valves and Accessories**

6.07.01 **General Requirements**



**WBPDCCL**

**EPC Bid Document  
Sagardighi Thermal Power Project  
1x660 MW Unit No. 5, Phase - III**

- a) All valves shall be of approved make and type and shall have cast/ forged steel bodies with covers and glands of proven design. The valves shall be provided with electric motors/solenoids and actuators as required.
- b) Valves and specialties to be supplied shall be used for various steam and water services of the power cycle system and shall be located indoor/ outdoor and on horizontal/vertical runs of the pipe lines. However, locating the valves on vertical runs should be avoided as far as possible.
- c) All valves shall, unless otherwise approved, have ends prepared for butt-welding and the internal diameter shall be the same as the internal diameter of the pipes to be joined. Where valves are accepted with flanges, they shall comply with the requirements of the approved Code of Practice for the respective pressure and temperature conditions of the piping system.
- d) All valves shall receive tests at Manufacturer's or Contractor's works in accordance with the specific requirements of the approved Codes of Practice so that the same is acceptable to IBR where applicable. Valves shall be rising stem or otherwise as approved by the Owner.
- e) Gate valves have been specified with the intention of achieving isolation and tight shut-off. In full open condition, these valves should offer minimum of resistance to fluid flow.
- f) Globe valves have been specified with the intention of achieving good control of fluid passing. The plug and seat will have therefore suitable profiles for obtaining such controlling action.
- g) Check valves have been specified in order to prevent reverse flow through them.
- h) Steam traps with strainers will be used in the drain lines from various steam pipes such that only condensed steam can be drained.
- i) All valves shall function smoothly without sticking, rubbing or vibration on opening or closing.
- j) Material, design, manufacture, testing etc. for all valves and specialties along with the accessories shall conform to the latest editions of codes as specified or approved equivalent and acceptable to IBR.
- k) **Integral Bypass Valves:**
  - i) The requirement of integral bypass valves shown in P&IDs, is the minimum required. The final requirement shall be worked out, as per process requirement, during detailed engineering.



**WBPDCCL**

**EPC Bid Document  
Sagardighi Thermal Power Project  
1x660 MW Unit No. 5, Phase - III**

- ii) If integral bypass valve selected is of size 50 mm Nb and below, then gate or globe type of forged construction with socket weld end as per ANSI B-16.11 shall be provided. For integral bypass valves of size 65 mm Nb and above, only cast steel gate valves with butt weld ends as per ANSI B 16.25 shall be provided.
  - iii) Bypass pipe shall be of seamless construction and thickness corresponding to minimum of schedule 80 and shall be of the same material class as the main pipe.
  - iv) Integral bypass shall be motor operated if main valve is motor operated.
- l) Motor operated valves shall be designed as specified hereinafter.
  - m) Valves subjected to vacuum shall have sufficient long deep-seated packing. Valves in general shall preferably be of such design as to permit repacking while in service by providing back seating arrangement duly tested during manufacture.
  - n) All flanged valves and specialties shall be provided with two (2) counter flanges, bolts, nuts, washers, gaskets etc.
  - o) Valves and specialties along with counter flanges coming under the purview of IBR shall meet all the requirements of IBR duly approved by the Owner.
  - p) For pneumatically actuated valve, if any, the Bidder shall provide necessary instrument air connection near the valve. All accessories including solenoid valves etc. as necessary for the actuation of this valve shall be supplied.
  - q) For all sizes below 50 mm, socket welded end valves may be used.
  - r) All valves shall have outside screwed spindles and screwed thread of spindle shall not pass through or into the stuffing box. Where valves are exposed to the weather, protective covers shall be provided for the spindles, which shall be subject to approval by Owner.
  - s) Valves requiring sealing water shall be adequately deep and shall be equipped with lantern ring to admit pressurised water for gland-sealing. Gland sealing water shall be tapped from one tapping point on the condensate extraction pumps discharge header and shall be reduced in pressure as per the requirement.
  - t) The stops which limit the travel of any valve in the "Open" or "Shut" position shall be arranged exterior to the valve body.
  - u) All regulating valves shall be designed to prevent erosion of the valve plugs and seats when the valves are operated partially opened. The valves shall have contoured plug.



**WBPDCCL**

**EPC Bid Document  
Sagardighi Thermal Power Project  
1x660 MW Unit No. 5, Phase - III**

- v) Approved access arrangements shall be provided for all valves and particular attention shall be given to those valves fitted with gearing, which require lubrication of the valve itself.
- w) Valves which cannot be operated from the floor or walkways shall be provided with suitable extension rods and linkages. If such a valve is provided with integral bypass then similar arrangement shall be done for the bypass valve also. The extension shall be such that the hand wheel is at a height of approximately one metre above the level of the floor or platform from which the valve is to be operated. Where required they shall be provided with head-stocks and pedestals of rigid construction and where gears or level wheels are used these shall be of cast steel or suitable quality cast iron with machine cut teeth. Where extension spindles are fitted, all thrust when opening or closing the valves shall be taken directly on the valve body. The extension linkage shall be so designed to take care of the thermal movements of the valve body with the pipe on which the valve is installed. The connection of the extension spindle to the valve stem shall be through a flexible coupling.

The extension spindle shall be of the same materials as that of the valve stem. The floor stands shall have column, not less than Group-B of ASTM-126. Necessary nuts and bolts for mounting the floor stands on foundation shall have to be provided. Adequate means of easy lubrication shall have to be provided for valves and operating extension components.

- x) Stems shall preferably be arranged vertically with gland at the top, however, in no circumstances must the stem be inclined downward from horizontal or gland be at the bottom. Globe valves shall be installed with the pressure under the disc. Valves shall not be fitted in inverted position.
- y) Where necessary, for accessibility, grease nipples shall be fitted at the end of extension piping and where possible these shall be grouped together and mounted on a common panel situated at a convenient position. A separate nipple shall be provided to lubricate each point.

The Contractor shall supply the first fill of oil or grease for these parts. The Contractor shall supply a suitable manually operated grease gun for the standard type of nipple provided.

- z) The spindles for all valves for use outside the building shall have weatherproof protection covers of approved construction.
- aa) All valves shall be fitted with indicators so that it may be readily seen whether the valves are open or shut. In the case of those valves fitted with extended spindles, indicators shall be fitted both to the extended spindles and to the valve spindles.
- bb) Plastic or bakelite valve hand wheels will not be accepted.



**WBPDC**

**EPC Bid Document  
Sagardighi Thermal Power Project  
1x660 MW Unit No. 5, Phase - III**

- cc) All valves shall be closed by rotating the hand wheel in a clockwise direction when looking at the faces of the hand wheel. The face of each hand wheel shall be clearly marked with the words 'Open' and 'Shut' with arrows adjacent to indicate the direction of rotation to which each refers.
- dd) Each valve hand wheel shall be fitted with a circular nameplate of a approved material indicating the valve tag number, duty or service intended and the function of the valve. The nameplates shall incorporate the colour code corresponding to the service of the piping.
- ee) Wherever practicable, heavy valves of total weight including actuator, drive motor, integral by-pass etc., equal to or greater than 500 kg. shall be provided with suitable lugs to permit direct suspension by hanger rods or direct resting on bottom support, as applicable.
- ff) Special attention shall be given to the operating mechanism for large size valves in order that quick and easy operation is obtained and maintenance is kept to a minimum.
- gg) Eyebolts shall be provided where necessary to facilitate handling heavy valves or parts of valves.
- hh) The Bidder shall supply with his bid and in addition during the course of the Contract, comprehensive drawings showing the design of valves, test pressure and working pressure/temperatures. They should include a parts list referring to the various materials used in the valve construction.
- ii) For high temperature application above 600°F (315°C), all gate valves shall preferably be of wedge type construction.
- jj) All sampling and root valves shall be of integral body bonnet type.
- kk) The control valves and accessories equipment furnished by the Bidder shall be designed, constructed and tested in accordance with the latest applicable requirements of code for pressure piping ANSI B 31.1, the ASME Boiler & pressure vessel code, Indian Boiler Regulation (IBR), ISA and other standards specified elsewhere as well as in accordance with all applicable requirements of the Federal Occupational Safety and Health Standards, USA or acceptable equal standards.

Seat tightness of the HP and LP bypass valves shall be equivalent to block valve tightness conforming to MSS SP61.

The Contractor shall furnish all the control valves under this package as finalized during detailed engineering stage depending on the process requirements. All the control valves provided by the Bidder shall meet the specifications requirements specified herein.



**WBPDCCL**

**EPC Bid Document**  
**Sagardighi Thermal Power Project**  
**1x660 MW Unit No. 5, Phase - III**

The start-up system control valves and HP & LP bypass control valves shall be proven in same application and shall be as per Owner's approval.

### 6.07.02 Design Requirements

- a) Design working pressure and temperature as well as pressure rating of all valves and specialties has been listed in Annexure-III and Annexure-IV of this Section. Valves and Specialties are to be supplied conforming to specified pressure rating.
- b) Carbon steel gate / globe / check valves in size 100 mm and below shall be in accordance with API-602 or any other approved international standards. Steel body gate valves shall preferably be in accordance with American Petroleum Institute, U.S.A. standard no. API-600 or other approved international standards.
- c) Globe valves shall generally conform to BS-1873 or approved international standards, subject to other requirement specified in the specification.
- d) Check valves shall conform to BS-1868 or approved international standards and shall be of swing check type.

For L.P. valves the body seat for swing check valves shall be inclined at such an angle as to minimise chatter. For H.P. valves, the seat is straight to take advantage of high fluid pressure for closing.

To enable the internal parts to be examined or renewed without removing the valves from the pipeline, the flanged cover should be used. The body shall be stamped with an arrow to indicate the correct flow direction.

e) **Safety Valve**

The safety relief valves shall be direct spring loaded type and shall be provided with casing levers. The valves shall be of rugged construction suitable for long periods of uninterrupted service. The safety relief valves shall conform to the requirements of ASME Boiler and pressure vessel code, Section-I/VIII and IBR as applicable and shall be installed as per recommended rules for the design of safety valve installations in ANSI B31.1.

f) **Motor Operated Valves**

- i) Motor operated valves shall be fitted with both hand and motor operating gears and where a by-pass valve is provided this also shall be provided with both hand and motor operated gear and interlocks to ensure that the by-pass valve is opened before the main valve. Each valve shall be complete with a device for automatically stopping the motor when the valve gate has reached the "full open" or "full close" position (with a minimum increase in the torque). The motor shall be placed in





**WBPDCCL**

**EPC Bid Document  
Sagardighi Thermal Power Project  
1x660 MW Unit No. 5, Phase - III**

such a position relative to the valve that there is no possibility of leakage of liquid, steam or corrosive gas from valve joints on the motor or control equipment.

- ii) The hand operating and motor operating mechanism shall be so interlocked that the hand operating mechanism is disconnected before the motor is started. Valves shall be provided with seating control and except where specifically approved by the Owner for small valves, a slipping clutch or other torque-limiting device shall be incorporated in the motor drive. The opening or closing the valve shall be controlled by means of push buttons labelled respectively "open" and "stop". The control shall be so arranged that the motor can be stopped with the valve in any position by means of "stop" push button and after having been stopped, can be re-started in either direction by the "open" or "close" push buttons hand operating mechanism shall be placed in an accessible position from the floor.
- iii) Necessary output signal (4-20 mA) shall be given for provision of positioning indicator in central control room.
- g) For reheater isolation, for hydraulic testing as well as wet lay up reheater isolating devices shall be provided on cold reheat and hot reheat lines, at boiler outlet. Isolating device shall consist of a robust cast steel body with carbon steel (ASTM A216 GR WCB) material for cold reheat application and alloy steel (ASTM A 217 GR WC 9) for hot reheat application suitable for pressure and temperature condition which they will be subjected. These shall be of welded type construction and shall form part of the pipeline during normal operation without any leakage.

Before hydrostatic test top cover and bonnets are removed and a separate test closure assembly with sealing rings are inserted to close the flow patch. The test closure assembly shall be of disc type construction with appropriate seal and a preloading lever to form a complete tight assembly for effective closure during hydraulic testing. Drains shall be provided on both side of the device to detect leakage.

h) **Drain Valves, Steam traps and Strainers**

i) **Drain Valves**

All drain valves shall be of approved type and shall have cast or forged steel bodies with covers and glands of approved construction. Spindles shall be of stainless steel and the materials of internal parts shall be suitable for operation at the maximum working pressure and temperature of the piping to which they are connected. Valves shall be full-way type, unless otherwise specified and in full open position the bore of the valve should not be obstructed by any part of the gate. The internal diameter of all valves at the bore and at the ends adjacent to the pipe work shall be similar to the internal



**WBPDCCL**

**EPC Bid Document  
Sagardighi Thermal Power Project  
1x660 MW Unit No. 5, Phase - III**

diameter of the connecting pipe work. Valves shall be designed for continuous operation in partially open condition without erosion of the valve seats or faces. Where valve seats are shrouded the design of the shroud shall be such as to prevent foreign matter lodging in the valve seat.

All drain traps shall be of approved make, size and type and shall be complete with air cock and casing mechanism. All internal parts shall be constructed from approved material and shall be renewable. Trap bodies and covers shall be of cast or forged steel and shall be suitable for operation at the maximum working pressure and temperature of the steam piping to which they are connected.

ii) **Steam Traps and Strainers**

- The steam traps shall be inverted bucket or thermodynamic type complete with integral or separate strainers.
- The internal components of traps shall be of AISI-316 stainless steel construction. Material of construction of the body shall be selected by the Contractor based on the service conditions stipulated.
- All Y-type strainers, wherever provided with steam traps or otherwise, shall have AISI-316 stainless steel screen of not more than 20 mesh size. Screen open area shall be at least three (3) times the pipe internal cross-sectional area. The strainer shall have a screwed blow-off connection with a removable plug. Material of construction of the body shall be selected by the Contractor based on the duty conditions specified.
- All traps and strainers shall have socket weld ends as per ANSI B16.11 for size NB 50 mm and smaller and butt weld ends as per B 16.25 for size NB 65 mm and above.
- Steam drain traps shall be provided with strainers, inlet and discharge valves and by-passes and test cocks as schematically indicated in the enclosed Tender drawings. Materials and other details of these valves shall meet the specified requirement.

i) **Pump Suction Strainer**

The strainer at condensate Transfer pump should be removable type conical strainer assembly. The spool pipe shall have flanged ends



**WBPDC**

**EPC Bid Document**  
**Sagardighi Thermal Power Project**  
**1x660 MW Unit No. 5, Phase - III**

suitable for direct mounting on condensate Transfer pump suction flange. The material of construction of spool pipe shall be the same as that of pumps suction piping. The strainer element shall be of perforated sheet with aperture size of 6 mm and wrapped with AISI-316 stainless steel wire mesh of 500-micron nominal aperture. The clear opening area of the strainer shall be at least 5 times the pipe area.

j) **Non-return Valves**

- i) All non-return valves shall be of approved type and make and the pressure drop shall be subject to approval. Non- return valves for steam services and on pump discharge sides shall be provided with approved dash pots, where required, and with prior approval from Owner.
- ii) The body seat for swing check valves shall be inclined at such an angle as to minimise chatter.
- iii) To enable the internal parts to be examined or removed without removing the valves from the pipeline, the flanged cover should be used. The bodies shall be stamped with an arrow to indicate the correct flow direction.
- iv) Provision shall be made to drain both sides of a horizontal non-return valve where such a valve adjoins an isolating valve. For non-return valves mounted on vertical pipe integral by-pass shall be used to facilitate draining as stated earlier.

k) **Desuperheaters**

Desuperheaters along with spray water supply and control system shall be provided on the auxiliary steam lines, etc. as required. A desuperheater shall be designed for the design conditions of the piping on its upstream side and shall also take care of its severe condition of working. As far as possible, the de-super heaters shall be mounted on a vertical line to avoid the problem of water accumulation in it. However, if installed horizontally, the inside diameter of the de-superheated shall be the same as that of the pipe on which it is mounted and the pipe shall be provided with drain pocket and trap station.

l) **CONTROL VALVES**

HP & LP Bypass valves, BFP recirculation valves, Reheater attemperation valve, soot blower control valve and High capacity



**WBPDCCL**

**EPC Bid Document**  
**Sagardighi Thermal Power Project**  
**1x660 MW Unit No. 5, Phase - III**

PRDS valve shall be of multi step design. For detail specification of control valves, refer Volume II-E.

**6.08.00 Flash Tank**

6.08.01 The flash tanks shall be adequately sized to take care of the total drains in the complete power cycle piping system. There shall be sufficient margin to accommodate the possible variation in drain quantities as well as flash steam. Flash tanks shall be designed as per the requirement of ASME Boiler and Pressure Vessels (B&PV) codes, & ANSI standard. The Bidder shall submit design calculation for flash tanks and basis of design parameter selection for Owner's review.

6.08.02 Flash tanks shall be provided into which all recoverable drains from turbine casing, extraction lines, valves, strainers, main steam, CRH and HRH line drains, cascaded drains from heaters etc. shall be led. Number of flash tanks shall as per tender drawings. Requirement /details of various flash tanks are given below:

- i) High pressure (HP) flash tank for accommodating high pressure (above and including hot reheat design pressure) steam drains and HP heater emergency drains, as indicated in the tender drawing.
- ii) Low pressure (LP) flash tank for accommodating low pressure (below hot reheat design pressure) steam drains and LP heater emergency drains as indicated in the tender drawing.
- iii) Atmospheric flash tank to accommodate alternate drains of steam lines, feed water safety valve discharge and aux. steam line drains, as indicated in the tender drawing.

**Schedule of materials**

Shell and Head - ASTM A 285 Gr.C  
 Wear Plate/Baffle - ASTM A 285 Gr.C  
 Nozzle Neck- ASTM A 106 Gr.B  
 Manhole nozzle flange and cover- ASTM A 285 Gr.C  
 Couplings - ASTM A 105  
 Bolts and studs - ASTM A 193 Gr. B7  
 Nuts - ASTM A 194 Gr. 2 H  
 Gaskets - Spiral wound SS 316 with graphite

6.08.03 Minimum design pressure and temperature for the flash tanks shall be 3.5 Kg/cm<sup>2</sup> (g) and 210 deg. C respectively. Flash tanks shall also be designed for full vacuum condition.

6.08.04 Corrosion allowance of 3.0 mm shall be added to the design thickness of the shell and head of the vessels. The minimum thickness of the vessels including corrosion allowance shall not be less than 8 mm.





**WBPDCCL**

**EPC Bid Document  
Sagardighi Thermal Power Project  
1x660 MW Unit No. 5, Phase - III**

- 6.08.05 The flash tanks and manifolds shall be designed to take care of the impact forces due to incoming drains.
- 6.08.06 In case the spray is in manifold, the material for the flash tank manifolds shall conform to ASTM A335 Gr. P22 or better and its thickness shall not be less than SCH 100 of ANSI B36.10 irrespective of temperature of the fluid handled.
- 6.08.07 The temperature in the flash tanks shall be maintained by using condensate/Feed water spray, as the case may be and in whichever case applicable. The spray shall be automatically controlled. However, for flash tanks open to atmosphere continuous spray through an orifice shall also be acceptable.
- 6.08.08 All design parameters shall be subject to Owner's approval.
- 6.09.00 **Metallic Expansion Joints**
- 6.09.01 The expansion joints shall be of metallic multi-bellows construction and shall be used to reduce the reactions (forces and moments) at the connected equipment terminals due to thermal expansion/connection and/or vibration of connected equipment and piping.
- 6.09.02 The design, material, construction, manufacture, inspection, testing and performance of the expansion joints shall comply with the currently applicable requirement of EJMA, Boiler and Pressure Vessel Code Section III, ANSI B-31.1 and all statutes, regulations and safety codes.

a) Material of bellow :

Based on material of bellow, bellows shall be categorized into three category namely Carbon steel, stainless steel (eg. SS304, 316, 321 etc.) & High alloy steel (eg. Inconel).

b) Profile of convolutions:

Each profile shall be considered as separate category (e.g. U profile, V profile & Lyra profile etc.).

c) Dimension of bellows:

Based on the size, the categories shall be as under:

- i) Nominal diameter of metallic expansion joint up to and including 800mm NB.
- ii) Nominal diameter of metallic expansion joint greater than 800mm NB up to & including 1600 NB.
- iii) Each size above 1600mm NB shall be a separate category.





**WBPDCCL**

**EPC Bid Document  
Sagardighi Thermal Power Project  
1x660 MW Unit No. 5, Phase - III**

d) Design pressure:

Based on the design pressure, bellows shall be categorized as under:

- i) Design pressure from full vacuum up to 5 kg / sq.cm (g).
- ii) Design pressure above 5 kg / sq.cm(g) and up to 10 kg / sq.cm (g) with or without vacuum.

e) Number of Cycles:

For the life cycle test, the number of test cycles shall be minimum 10,000 cycles.

Other tests for metallic expansion joints shall be carried out as per the approved QP/QA procedure. Further, other terms and conditions for type test shall be as specified elsewhere in the specification.

f) Construction details:

Bellows:

The bellow shall be hydraulically or roll formed from perfect cylinders of single ply. The number of longitudinal weld seams shall be minimum and there shall be no circumferential weld seam. Cold formed stainless steel bellows shall not be heat treated. All bellow elements shall be pickled after forming. Equalizing rings, where required, shall be either from high quality casting or from fabrication metal. Flanged expansion joints shall be provided with adequate pipe stubs. Butt welded expansion joints shall have adequate length of pipe so that site welding dose not impair or reduce the joints efficiency.

Sleeves

Expansion joints will be furnishes with internal sleeves of the same material as the bellows and installed with sufficient clearance to allow full rated deflection. The sleeves shall be welded on the flow inlet end of the joint only. Bellow shall have external sleeves with an arrow including the direction of flow on the outside. The external steel covers provided to protect bellows from physical damages, shall be suitable for supporting insulation where necessary and shall be detachable.

Tie bars:

Joints shall be shipped at neutral length. They shall be provided with suitable erection and knock-off type temporary tie bars to prevent damage and misalignment during transit and also with permanent tie bars along with necessary nuts, bolts, etc. The rod on pressure balanced type expansion joints shall be adequately sized to prevent buckling in vacuum services or services other than external loads.

6.09.03 All design parameters shall be subject to Owner's approval.

**7.00.00 INSPECTION, TESTING AND INSTALLATION**





**WBPDCCL**

**EPC Bid Document  
Sagardighi Thermal Power Project  
1x660 MW Unit No. 5, Phase - III**

**7.01.00 Testing of Piping at Works**

**7.01.01 Material Test and Analysis**

All materials shall be furnished in strict accordance with the codes specified and in accordance with the detailed specification. All sources of material shall be disclosed and relevant test certificates for the physical and chemical properties of the material shall be made available to the Owner before the final shop inspection.

**7.01.02 Hydrostatic Test**

All piping shall be subjected to the hydrostatic test pressure at shop for a duration of 30 minutes (min) as required by the IBR or any other applicable standards. Test pressure shall however be not less than the following :

Test Pressure =

$$1.5 \times \frac{\text{Allowable Stress at Room Temp.}}{\text{Allowable Stress at Design Temp.}} \times \text{Design Pressure}$$

The Contractor shall guarantee his work as capable of withstanding such hydrostatic tests and consent to repair or replace at his expense any item, which fails to pass such tests at site. Hydrostatic test of all pipes coming under IBR shall be offered for witnessing by the representative of the Inspecting Authority recognised by IBR.

**7.01.03 Wall Thickness Tests**

Wall thickness tests shall be made on a length of pipe of each type to determine the actual wall thickness at outer wall of bend on such piping.

The tests shall be done before fabrication on the piping system and results submitted to Owner for approval.

**7.02.00 Capacity Tests for Pipe Supports**

Each constant load and spring support shall be tested before delivery to ensure that the variation in support capacity provided through the specified ranges (i.e. the difference in load between hot conditions and cold condition) does not exceed 6 percent for constant load supports and 20 percent for variable spring supports.

All materials shall be of tested quality. Hanger springs shall be properly calibrated.

**7.03.00 Testing of Valves & Specialties at Works**

**7.03.01** All materials shall be of tested quality and the Contractor shall submit the relevant material test certificate for the approval of Owner/Consultant.





**WBPDCCL**

**EPC Bid Document  
Sagardighi Thermal Power Project  
1x660 MW Unit No. 5, Phase - III**

7.03.02 All Valves and Specialties as well as counter flanges to be used in steam service shall have IBR certification marked on them and IBR certificates in appropriate proforma shall be submitted.

7.03.03 Gate valves shall be subjected to shop tests in accordance with API-598 including the high-pressure closure test. Globe valves shall be tested in accordance with BS-1873 and check valves in accordance with BS-1868.

7.03.04 All gaskets used for test shall be of the same material and design as specified for the finished product.

7.03.05 Each relief valve shall be subjected to hydrostatic test, seat pressure test, seat leakage test and test for relieving capacity.

The valve body test pressure shall be at least twice the set pressure.

The seat test pressure should be at least equal to the set pressure. During this test, the valve seat shall be demonstrated to be watertight for a period of at least two (2) minutes.

7.03.06 Functional tests : The fully assembled or completed valves including the operators and accessories shall be functionally tested to demonstrate the operability of the valve and the operator. This may be done by cycling typical valves 3 or 4 times from open to close position. The manual operation of the motor operated valves using the manual override to demonstrate freedom from friction shall also be conducted.

7.03.07 All Control valves shall be tested in accordance with the quality assurance programme agreed between the Owner and Contractor which shall meet the requirements of IBR and other applicable codes mentioned elsewhere in the specifications. The tests shall include but not be limited to the following:

Non destructive test as per ANSI B-16.34. Hydrostatic shell test in accordance with ANSI B 16.34 prior to seat leakage test.

Valve closure test and seat leakage test in accordance with ANSI- B 16.34 and as per the leakage class.

Functional test: The fully assembled valves including actuators control devices and accessories shall be functionally tested to demonstrate times from open to close position.

CV test: CV test shall be carried out as type test on each size, type and design of the valves as per ISA 75.02 standard and test report shall be furnished for Owner's approval.

**7.04.00 Tests on Strainers and Traps at Works**

7.04.01 All strainers shall be subjected to hydrostatic test. The test pressure shall be twice the design pressure.



**WBPDCCL**

**EPC Bid Document**  
**Sagardighi Thermal Power Project**  
**1x660 MW Unit No. 5, Phase - III**

7.04.02 All steam traps shall be subjected to hydrostatic test at twice the design pressure. IBR certification shall be furnished for all steam traps.

7.05.00 Test reports and certificates of the mentioned tests and other tests as required to ensure satisfactory operation shall be submitted to Owner/Consultant before despatch of equipment IBR certification as required shall be furnished.

7.06.00 All rubber lining should be subjected to tests as per IS: 4682 (Part-I).

7.07.00 **Tests at Site**

Contractor shall carry out tests at site to prove to the Owner that the equipment of the plant complies with requirements stipulated and is erected in accordance with requirements. Before the plant is put on trial run the Contractor will be required to conduct tests to demonstrate to the Owner that each item of the plant is capable of correctly performing the functions for which it was specified. These tests may be conducted concurrently with those required under commissioning sequence. Tests required shall in general be as follows :

- a) All piping, valves and specialties after installation, will be tested hydraulically at a pressure, one and a half times that of the maximum design/working pressure in the system for a minimum duration of thirty (30) minutes to check against leak tightness.
- b) All manually operated valves/gates shall be operated throughout 100% of the travel and these should function without any trouble whatsoever.
- c) Visual check on all structural components, welding, painting etc. and if doubt arises these will be tested again.
- d) All test instruments and equipment shall be furnished by the Bidder to the satisfaction of the Owner.
- e) Checks on electrical items as mentioned in relevant electrical specification.

7.08.00 **Pre-Commissioning Testing**

7.08.01 **Alignment Test**

After completion of erection and before start-up, alignment test shall be carried out by the Contractor to check levelling, clearance, eccentricity etc. Measurement will be witnessed and acceptance will be certified by the Owner.



**WBPDCCL**

**EPC Bid Document**  
**Sagardighi Thermal Power Project**  
**1x660 MW Unit No. 5, Phase - III**

7.08.02

**Heat Treatment**

All necessary preheating, post heating and stress relieving operation of welds/fabricated, items are part of the erection work and shall be supervised by the Contractor in accordance with relevant regulations and standard.

The Contractor shall arrange all required supervising staff for heat treatment and stress relieving works.

Heat treatment may be required to be carried out at any time during day and night to ensure the continuity of the progress. The Contractor shall provide supervising staff accordingly.

All data such as heating temperature, heating rate, sparking time; maximum temperature during heat treatment shall be properly recorded. All the data recorded during heat treatment shall be the property of the Owner.

7.08.03

**Radiography Test**

The Contractor shall carryout radiography tests of all field-welded joints coming under IBR the acceptability standard of which shall be as per IBR (latest revision). For other field welded joints radiography or other non-destructive testing (NDT) methods shall be employed as per ASME or equivalent standards. All radiography shall be carried out in presence of a competent supervisor of the Contractor and his certificate of identification of the films of the radiographs shall be given invariably in all cases.

The repair work shall be suggested by the Contractor immediately after detection of the defective zone to the complete satisfaction of the Owner. Regarding acceptance of the joints, decision of the Owner shall be final.

All X-ray films of joints radiographed at site shall become the property of the Owner.

Contractor shall carryout the following optional non-destructive tests after completion of erection of all piping and equipment.

Ultrasonic test per weld joint.

Hardness test for 10% weld joints for each system of piping and/or as specified in the approved Field Quality Plan (FQP).

7.08.04

**Hydrotest**

Hydro testing shall be conducted for all pressure parts after installation at required pressure irrespective of carrying out 100% radiography of field welded joints. All necessary blanking arrangement required for such hydrotesting shall be furnished by the Contractor. The hydro testing of piping coming under the I.B.R. shall meet the requirements of I.B.R. and all necessary test pump, temporary piping etc. shall be supplied by the Erection Contractor, irrespective of carrying out radiography on 100% basis of the field welded joints.



**WBPDC**

**EPC Bid Document**  
**Sagardighi Thermal Power Project**  
**1x660 MW Unit No. 5, Phase - III**

After the hydrostatic test, the Erection Contractor shall carry out thorough flushing of all lines with water to ensure removal of foreign materials like welding rods, metal chips etc. to the satisfaction of Owner. After the flushing of the lines, all the water shall be drained and the piping shall be blown with air for drying the cleaned surface and the lines shall be air blasted to ensure proper cleaning of line to the satisfaction of Owner.

As a rule, hydro test shall be performed after all eventual pipe branching have been completed and valves installed. Should it be required to hasten erection work, hydrotest may be performed in sections.

All safety valves coming under purview of Indian Boiler Regulation shall be set and other tests shall be conducted to the satisfaction of concerned Boiler Inspector. All other safety valves shall also be set and sealed to the satisfaction of the Owner.

All instruments necessary for the tests shall be supplied by the Contractor and calibrated before test as per relevant code.

The Contractor shall make necessary changes and corrections without any extra cost as may be felt by the Owner/Consultant to meet the guarantee and other technical particulars.

#### 7.08.05 **Testing Requirements**

The detailed testing requirements for power cycle piping and its components are given in the subsection for Quality Assurance(QA) .The requirements pertaining to testing given in this subsection if in variance with that given in QA subsection, then the more stringent of the two shall be followed.

#### 7.09.00 **Installation**

7.09.01 For all steam blowing lines temporary strainers shall be installed at the equipment terminals so as to prevent any inflow of particles where that may cause any damage or harmful effect. For example, such strainers shall be placed on main steam and hot reheat line terminals at turbine end unless the turbine stop valves/interceptor valves have integral strainers suitable for the purpose. The temporary strainers shall be kept on line for sometime after the plant starts normal operation, as per the discretion of the Owner. So, the design of strainers shall be based on the design conditions of the pipes on which they are installed. Where flow meters are to be installed in pipes requiring steam blowing, initially the pipes shall be erected with the flow meter branch pipes replaced by temporary spool pieces. After the end of steam blowing operation the temporary spool pieces shall be removed and the flow meter branch pieces shall be erected in position. In case such a pipe has also to be subject to cold pull- up, temporary anchoring of the main pipe on either ends of the temporary spool piece shall be done before replacing it by the flow-meter branch pipe.

All piping shall be installed in a manner such that expansion will take place in the direction desired so that vibrations will be minimised. The Contractor shall



**WBPDC**

**EPC Bid Document  
Sagardighi Thermal Power Project  
1x660 MW Unit No. 5, Phase - III**

be responsible for the expansion provisions and flexibility of all field run piping. No piping shall be cold-sprung or cold-pulled.

The forces and moments on the temporary anchors and attachments shall be submitted. The cold pull-ups and all the above-mentioned documents shall be subject to the approval of the Owner.

7.09.02

All expansion bellows shall be installed with a minimum of two tie rods or bolts across each bellows to prevent the bellows from opening under pressure. The connection of the tie rods or bolts to the pipe shall make adequate provision for angular movement of the pipe and bellows.

Pump suction pipes shall be installed in such a manner that no air can be trapped in the suction piping. Suction pipes shall be supported in such a manner that there will be no high spots where air can be trapped. The in trades of suction branch lines shall be in no place lower than the in trades of the manifold at the point where the branch line connects to the manifold.

Standard "Factory Made" fittings shall be used in all piping. Shop or site fabricated mitred fittings shall not be used unless accepted by the Owner.

When C-clamps are tack welded to the pipe for the purpose of alignments of a joint, preheating for the tack welding shall be performed if the main joint adjacent to it to be preheated as per the requirements of this specification, otherwise preheating for the tack weld may be omitted. After the joint is completed, all tack welds shall be removed flushed with the adjacent surface of pipe by chipping and/or grinding. The areas where C-clamps were attached shall be subjected to stress relieving as required.

The hydrostatic testing of the piping system shall be done after proper installation of all permanent hangers supports. Spring hangers shall be locked during hydrostatic test. Prior to steam blowing all hangers which had been locked for the hydrostatic testing shall be unlocked.

The setting and logging of all supports, restraints/limit stop, spring hangers, etc. is the responsibility of the Bidder. The initial setting on all hangers and supports and clearance on restraints and limit stops shall correspond to the design cold values. The Bidder shall check all readings after completion of erection of piping system and application of insulation and carry out readjustment as necessary to be in line with the design cold values. After satisfactory setting of all hangers/restraints, hanger readings/clearances shall be logged by the Bidder in proper format and a joint protocol to be made.

The Bidder shall monitor the behavior of all hangers, supports, restraints etc. during the initial stages of plant operation. When the piping system(s) have attained their rated temperature the Bidder shall log, hanger readings, snubber deflections, restraints / limits stop clearances, as specified elsewhere. All gaskets shall be asbestos free material and suitable for the service application.

7.09.03

During erection no weights must be lifted by means of tackle fastened to the beams or slabs of the floor or roof except where provision has been specifically made for this purpose.





**WBPDC**

**EPC Bid Document  
Sagardighi Thermal Power Project  
1x660 MW Unit No. 5, Phase - III**

Supporting straps around flanges of pipes or valves or around welded joints will not be accepted. Anchors shall be attached to pipe by approved means. All supports should be shop fabricated and should be positioned before erection of the piping takes place and near to joints and valves wherever possible.

- 7.09.04 The Contractor shall provide all the necessary wall boxes and collars where pipes pass through walls, floors and roofs, also the necessary supports for any trenched pipes. Roof collars shall be fitted with a high sealing to prevent water falling through the holes.

The wall boxes and floor collars shall be constructed so that they can if necessary be erected after the pipes are in position. Pipes passing through roof collars shall be provided with an approved pipe sleeves, weather hood and cowl which shall be fixed by the Contractor. Floor collars shall extend to an approved height above the floor level and the pipes shall be fitted with hoods where required.

- 7.09.05 Drain pipe work shall be designed as per ANSI B31.1.

High pressure drains (above 40 kg/sq.cm) shall have two valves in series and that near the condenser or flash box shall be motor operated arranged to open and close to ensure minimum wear on one valve.

No part of any drain line may be below its terminal point at the condenser, drain collection header or other drain vessel. All drain manifold connections to the condenser or flash tank must be above the maximum water level in the tank.

High-pressure drains shall have a screw-down non-return valve at the point of discharge near the manifold of the Flash tank to prevent back flow of flashed steam.

Drain line should be connected at a 45 degree angle to the manifold axial centerline with the drain line discharge pointing towards the condenser.

Low-pressure drains shall have steam traps of an approved design complete with strainers, isolating valves and by-pass valves.

Low-pressure drains shall have an isolating valve at the point of take-off from the pipe or vessel to be drained or as near as possible for convenient operation.

Pipe wall thickness shall be as per international standard approved by Owner/Consultant during detailed engineering stage.

Drain pockets of an approved size and construction shall be provided for all steam lines.





**WBPDCCL**

**EPC Bid Document  
Sagardighi Thermal Power Project  
1x660 MW Unit No. 5, Phase - III**

Arrangement of valves in the drain line shall be as shown in the Bidder's P & I Diagram.

7.09.06 All electrical actuators and pneumatic/hydraulic actuator shall be erected, aligned, adjusted and finally set to the satisfaction of the Owner. This includes adjustment and setting of torque and limit switches.

All design parameters shall be subject to Owner's approval.

**7.10.00 Steam Blowing of Piping**

7.10.01 Steam blowing shall include engineering, supply and installation of all temporary piping, valves, fittings including quick actuating valves (for puffing purposes), supports, blanking plates, spools, target plates, instruments, controls and all other accessories and services required to complete the cleaning process as specified herein.

7.10.02 The detailed schemes and procedure for steam blowing operations shall be prepared and furnished by the Bidder and discussed and finalized during the detailed engineering stage the bidder shall make an estimate based on his experience for the piping system defined below, taking into consideration all temporary piping, consumables etc. required.

7.10.03 Steam blowing shall also include reinstatement of cleaned piping systems; and dismantling/removal of all temporary piping, equipment and materials from site. All temporary piping, valves, equipment and materials shall be taken back by the Bidder upon satisfactory completion of cleaning, and shall be removed from the Owner's premises.

7.10.04 Engineering involved regarding temporary piping shall include the following:

- i) Selection of temporary piping including disturbance factor calculation.
- ii) Preparation of layout of temporary piping and performing stress analysis as per ASME B 31.1.
- iii) Selection of temporary hangers and supports as required.

7.10.05 The following piping systems shall be cleaned through steam blowing operation :

- i) Main steam.
- ii) Hot reheat.
- iii) Cold reheat.
- iv) HP Bypass & LP bypass.
- v) Complete Auxiliary steam system including TG gland sealing lines.





**WBPDCCL**

**EPC Bid Document  
Sagardighi Thermal Power Project  
1x660 MW Unit No. 5, Phase - III**

vi) Steam lines feeding turbines of boiler feed pumps and their exhausts to condenser.

- 7.10.06 Steam blowing shall be carried out for removal of particles (rust, scales, weld splatter etc.) from various piping systems to avoid damage to turbine blade's. Cleanliness of system shall be checked by means of test plates made of steel which will be installed in the centre line of the piping system.
- 7.10.07 Cleaning shall be achieved by steam purging i.e. by blowing of steam through the piping such that the momentum of flow is greater than that of steam flow during normal operation of unit (at MCR).
- 7.10.08 The blow off shall be done with steam which is exhausted through adequately sized, open ended temporary piping. Temporary piping and motor operated valves shall be installed for steam blowing operation. Pressure shall be built up in the boiler and the piping warmed before release of steam by quick opening of motor operated valve located on temporary piping. The cycle shall be repeated until steam from the blow out pipe is determined to be clean.
- 7.10.09 If erected already flow nozzles and control valves etc. shall be removed and replaced by spool pieces before steam blowing. The removed flow nozzle and control valves etc. shall be put back after steam blowing.
- 7.10.10 The motor operated valves used for steam blowing shall have special characteristics like minimum loss of pressure, resistance to wear during grave working conditions (high velocity and carryover of water and solid particles), quick opening time, minimum effort on electric actuator etc.
- 7.10.11 The steam blowing termination criteria will be:
- i) Acceptable target plate condition
  - ii) Measured D.F. (disturbance factor) more than 1.4

The required values to calculate actual D.F. will be measured at site. The criteria for acceptable target plate condition shall be finalized during detailed engineering.

**7.11.00 Chemical Cleaning of Piping Systems and Equipments**

- 7.11.01 It is intended to chemically clean the following piping system
- i) Boiler feed piping
  - ii) Heater drains piping
  - iii) Main condensate piping



**WBPDCCL**

**EPC Bid Document  
Sagardighi Thermal Power Project  
1x660 MW Unit No. 5, Phase - III**

- iv) Extraction steam piping
- v) The following equipment which form a part of the above system shall also be included in the cleaning operation :
  - a) H.P. Heaters
  - b) L.P. Heaters
  - c) Deaerator
  - d) Gland steam cooler
  - e) Drain cooler

7.11.02 Before introducing chemicals, all the piping systems and equipment listed above shall be water flushed. Water flushing will be followed by alkaline cleaning acid cleaning and passivation.

7.11.03 However, the Bidder shall submit along with the offer his usual procedures and practices for chemical cleaning of the piping and equipment specified. The Bidder shall submit all schematics, write up, details of chemicals to be used etc. and detailed procedures he intends to follow. These schematics and procedures shall be subject to the approval of the Owner.

7.11.04 Pre-Cleaning Procedure: Prior to starting any phase of cleaning operation the following procedures shall be ensured.

- i) Installation of all temporary piping, valves, pumps and equipments as required for the flushing and chemical cleaning operations.
- ii) Temporary piping shall be routed at floor level as far as possible and secured in place to prevent movement vibration beyond acceptable limits.
- iii) Installation of the instruments as required to ensure satisfactory monitoring and control of the cleaning process. The Bidder shall also determine and arrange locations for sampling of the cleaning solution during cleaning.
- iv) Bypassing all regulation/control valves coming in the cleaning circuit or installation of temporary spool pieces.
- v) Installation of special end covers and temporary suction strainers, for boiler feed pumps and condensate pumps. Pump internals shall not be installed.
- vi) Installation of plastic seal in the condenser neck to protect the turbine from alkaline fumes.
- vii) Blocking and securing of all spring hangers in the steam lines which may be flooded during the cleaning operation.

7.12.00 **Surface Preparation & Painting**



**WBPDCCL**

**EPC Bid Document  
Sagardighi Thermal Power Project  
1x660 MW Unit No. 5, Phase - III**

- 7.12.01 Surface preparation methods and paint/primer materials shall be of the type specified herein. If the Bidder desires to use any paint/primer materials other than that specified, specific approval shall be obtained by the Bidder in writing from the Owner for using the substitute material.
- 7.12.02 All paints shall be delivered to job site in manufacturers sealed containers. Each container shall be labeled by the manufacturer with the manufacturer's name, type of paint, batch number and Color.
- 7.12.03 Unless specified otherwise, paint shall not be applied to surfaces of insulation, surfaces of stainless steel/nickel/ copper/brass/ monel/ aluminum/ hostelry/lead/ galvanized steel items, valve stem, pump rods, shafts, gauges, bearing and contact surfaces, lined or clad surfaces.
- 7.12.04 All pipelines shall be Color coded for identification as per the agreed Colour coding scheme, which will be furnished to the Bidder during detailed engineering.
- 7.12.05 Surface Preparation:
- i) All surfaces to be painted shall be thoroughly cleaned of oil, grease and other foreign matter. Surfaces shall be free of moisture and contamination from chemicals and solvents.
  - ii) The following surface schemes are envisaged here. Depending upon requirement any one or a combination of these schemes may be used for surface preparation before application of primer.
    - SP1 Solvent cleaning.
    - SP2 Application of rust converter (Ruskil or equivalent grade).
    - SP3 Power tool cleaning.
    - SP4 Shot blasting (shot blasting shall be used as surface preparation method for hot worked pipes prior to application of primer).
    - SP4\* Shot blast cleaning/ abrasive blast cleaning to SA21/2 (near white metal) 35-50 microns.
    - SP5 Phosphating.
    - SP6 Emery sheet cleaning/Manual wire brush cleaning.

#### Application of Primer/Paint

1. The paint/primer manufacturer's instructions covering thinning, mixing, method of application, handling and drying time shall be strictly followed and considered as part of this specification.





**WBPDCCL**

**EPC Bid Document  
Sagardighi Thermal Power Project  
1x660 MW Unit No. 5, Phase - III**

The Dry film thickness (DFT) of primer/paint shall be as specified herein.

2. Surfaces prepared as per the surface preparation scheme indicated herein shall be applied with primer paint within 6 hours after preparation of surfaces.
3. Where primer coat has been applied in the shop, the primer coat shall be carefully examined, cleaned and spot primed with one coat of the primer before applying intermediate and finish coats. When the primer coat has not been applied in the shop, primer coat shall be applied by brushing, rolling or spraying on the same day as the surface is prepared. Primer coat shall be applied prior to intermediate and finish coats.
4. Steel surfaces that will be concealed by building walls shall be primed and finish painted before the floor is erected. Tops of structural steel members that will be covered by grating shall be primed and finish painted before the grating is permanently secured.
5. Following are the Primer/painting schemes envisaged herein:

PS3 Zinc Chrome Primer (Alkyd base) by brush/Spray to IS104.

PS3\* Zinc Chrome primer (Alkyd base) by dip coat.

PS4 Synthetic Enamel (long oil alkyd) to IS2932.

PS5 Red oxide zinc phosphate to IS-12744. PS9- Aluminum paint to IS 2339.

PS9\* Heat resistant Aluminum paint to IS-13183 Gr.-I (for temperature above 400°C) and to IS-13183 Gr.-II (for temperature 200°C - 400°C)

PS13 Rust preventive fluid by spray, dip or brush.

PS14 Weldable primer-Deoxaluminat or equivalent.

PS16 High Build Epoxy CDC mastic.

PS17 Aliphatic Acrylic Polyurethane CDE134, %V=40.0(min.)

PS18 Epoxy based TiO<sub>2</sub> pigmented coat PS19- Epoxy based Zinc phosphate primer (92% zinc in dry film (min.),

%VS=40.0(min.). PS20- Epoxy based finish paint.



**WBPDCCL**

**EPC Bid Document  
Sagardighi Thermal Power Project  
1x660 MW Unit No. 5, Phase - III**

6. All weld edge preparation for site welding shall be applied with one coat of weldable primer.
7. For internal protection of pipes/tubes, VCI pellets shall be used at both ends after sponge testing and ends capped. VCI pellets shall not be used for SS components and composite assemblies.

### 7.13.00 **Broad Guidelines for Erection and Installation of LP Piping**

- 7.13.01 All fittings like "T" pieces, flanges, reducers etc. shall be suitably matched with pipes for welding. The valves will have to be checked, cleaned or overhauled in full or in part before erection, after chemical cleaning and during commissioning.
- 7.13.02 Adjustments like removal of oval ties in pipes and opening or closing the fabricated bends of high pressure piping to suit the layout shall be considered part of work and the Erection contractor is required to carry out such work as per instruction of Bidder/Owner, which shall include specified heat-treatment procedures, etc. also wherever required.
- 7.13.03 Certain adjustments in length may be necessary while erecting high pressure pipelines and the Erection contractor should remove the extra lengths to suit the final layout after preparing edges afresh and adopting specified heat treatment procedures.
- 7.13.04 Suspension for piping, pressure parts, etc., will be supplied in running lengths, which shall be cut to suitable sizes and adjusted as required.
- 7.13.05 All the valves, lifting equipments, actuators, power cylinders, etc., shall be serviced and lubricated to the satisfaction of Engineer before erecting the same and also during pre-commissioning. Even after commissioning, the equipments, if there are problems in the operation, they have to be attended to by the Bidder during the tenure of the contract. Welding or jointing of extension spindle for valves to suit the site conditions and operational facility shall be part of erection work.
- 7.13.06 All tubes and pipes shall be cleaned and blown with compressed air and shown to the engineer before lifting. Bigger size pipes should be cleaned with flexible wire brush, wherever necessary. After cleaning is over the end caps shall be put back in tube openings till such time they are welded to other tubes.
- 7.13.07 Fine fittings, drain piping, oil systems & other small bore piping have to be routed according to site conditions and hence shall be done only in position. As such, layout of small-bore piping shall be done as per site requirement. There is a possibility of slight change in routing the above pipelines even after completion of erection, which shall be carried out by the Bidder without any extra cost to the Owner. Work shall also include fabrication of small bends at site from straight lengths to suit the site conditions.
- 7.13.08 No temporary supports shall be welded on the pressure parts. Welding of temporary supports, cleats, etc., on the building columns shall also be



**WBPDCCL**

**EPC Bid Document**  
**Sagardighi Thermal Power Project**  
**1x660 MW Unit No. 5, Phase - III**

avoided. In case of absolute necessity, Erection contractor shall take prior approval from Owner. Further, any cutting or alteration of member of the structure or platform or other equipments shall not be done without specific prior approval of Owner.

- 7.13.09 Wherever piping erected by the Erection Contractor is connected to piping or equipment erected by some other agencies the joint at the connecting point shall be considered under this specification.
- 7.13.10
- a) All piping shall be grouped wherever practicable and shall be routed to present a neat appearance.
  - b) The piping shall be arranged to provide clearance for the removal of equipment for maintenance and for easy access to valves, instruments and other piping accessories required for operational maintenance.
  - c) Piping shall be routed above ground unless otherwise specifically indicated/ approved by the Engineer. In such special case, the piping may be arranged in trenches, or buried and properly protected as per AWWA Standards.
  - d) Overhead piping shall have a minimum overhead clearance of 4 meters above walkways and working areas and 6 meters above roadways unless otherwise approved by the Engineer.
  - e) Drains shall be provided at all low points and vents at high points as per actual layout regardless of whether some have been shown in respective drawings or not. The pipelines shall be sloped towards the drain points.
- 7.13.11 All drips and drains for piping and equipment whether shown in the drawings or not shall terminate on the ground floor up to station drain unless otherwise specified. Leading such drains up to station drainage is also the responsibility of the Contractor.

## **8.00.00 DRAWINGS, DATA, INFORMATION & MANUALS**

- 8.01.00 Drawings, data, Information to be furnished by the Bidder along with the Bid.
- 8.01.01 A complete list of all piping systems and corresponding materials included in the scope of work.
- 8.01.02 A complete list of all valves with their quantities and ratings.
- 8.01.03 Manufacturer's catalogue indicating design and construction of spring hangers, valves, specialties offered.
- 8.01.04 Manufacturer's catalogue indicating complete range of available size and rating of pipes and fittings.
- 8.02.00 **After Award of Contract**



**WBPDC**

**EPC Bid Document**  
**Sagardighi Thermal Power Project**  
**1x660 MW Unit No. 5, Phase - III**

- 8.02.01 Layout drawings as well as Isometric drawings (for line sizes NB 50 mm and larger) showing the routing of various piping and location of hangers, restraints, anchors, valves etc.
- 8.02.02 Detail fabrication drawings of all shop fabricated piping system indicating design parameters and complete bill of material (Relevant Standards and grades to be indicated) and information/ data pertaining to the hydrostatic and non-destructive test requirements.
- 8.02.03 Detail dimensioned drawing of each valve, specialties, indicating tag no., pressure rating, manufacturing standard, bill of material and hydrostatic test pressures. The drawing shall include the end preparation details and shall indicate the position of the hand wheel/operator. Technical particulars of motor operators wherever applicable shall also be indicated.
- 8.02.04 Detail dimensioned drawing of each type of hangers and supports including guides, anchors, snubbers etc. with bill of materials (relevant standards and grades to be indicated).
- 8.02.05 General arrangement drawing for each hanger/support/anchor etc. indicating identification number, auxiliary supporting structural details, other details and information as required in the specification and typical details of Hangers & supports drawing enclosed with the specification.
- 8.02.06 Wiring diagram for all limit switches of motor operated valves.
- 8.02.07 Detail drawing with design calculation for the special Y-fittings on pipes, if any.
- 8.02.08 The loading data required for design of structures.
- 8.02.09 **Miscellaneous Data/Documents**
- a) Complete schedule of pipe lines in a format as approved by the Owner/Consultant indicating at least the line number, line description, pipe class (as per specification designation) design pressure and temperature, hydrostatic test pressure, insulation thickness, valve specification code, pipe material indicating standard and grade, number of BW/SW/Flanged joints and whether IBR certification needed
  - b) Complete schedule of valves in format as approved by the Owner/Consultant indicating at least tag no, location, size, pressure class, design parameters, operation, make, quantity, special requirement if any etc.
  - c) Bill of material of hangers and supports in a format approved by the Owner/Consultant indicating at least the hanger/support number, type, operating load, cold setting load, Hydrostatic test load, movement of attachment point in X, Y and Z direction, line no. on which the hanger/support is located, insulation thickness of the pipe line, hanger





**WBPDC**

**EPC Bid Document  
Sagardighi Thermal Power Project  
1x660 MW Unit No. 5, Phase - III**

rod length, angular deflection of hanger rod from vertical under hot and cold conditions etc.

- d) Approval certificates from IBR in relevant forms regarding design, fabrication and testing of piping and valves for the piping system, which are under the purview of IBR.
- e) Design calculation for pipe wall thickness finally adopted.
- f) Reinforcement calculations as per ANSI B 31.1 for all set on type branch connections.
- g) A document containing the flexibility analysis procedure and results showing the forces and moments at various support points, anchors, equipment terminals etc. as elaborated before in this specification.
- h) Procedure of shop and site tests, test reports and test certificates for all tests conducted at shop.
- i) Quality assurance schedule, including report containing all pertinent details of the heat-treating cycle for all pipes, fittings, valves, specialties etc.
- j) Detailed erection procedure for piping, valves, specialties and auxiliary equipment including complete details of welding of joints to be done at site. All necessary instructions/recommendation shall be given for satisfactory erection of piping, valves specialties and auxiliary equipment.
- k) Erection, operation and maintenance manuals.



**WBPDCCL**

**EPC Bid Document  
Sagardighi Thermal Power Project  
1x660 MW Unit No. 5, Phase - III**

**Annexure-I****LIST OF POWER CYCLE PIPING**

The following list of power cycle piping is an indicative one and is provided for the guidance of the Bidder only. Items not mentioned but deemed necessary by the Bidder for making the system complete, reliable and efficient shall also be included. This shall be read in conjunction with Clause No. 4.00.00 of this section and tender drawings.

<b>Sl. No.</b>	<b>Name</b>	<b>Description</b>
1.	Main Steam lines	: From Superheater outlet to inlet of turbine.
2.	Main steam Equalising line	: Between RHS and LHS main steam lines.
3.	HP By-pass line	: Between Main steam equalising line and Cold reheat line.
4.	Cold Reheat line	: Between HP turbine outlet and Reheater.
5.	Extraction line from CRH	: Between CRH and Deaerator.
6.	Extraction line from CRH	: Between CRH and H.P. heater.
7.	Extraction line from MS equalising line	: From MS equalising line to turbine auxiliary header.
8.	Steam supply to BFP Turbine	: From the main and alternative steam source point to BFP Turbine inlet. Alternative Source of Steam shall be CRH Line and HT Steam Header.
9.	Extraction from BFP discharge	: Between BFP discharge and H.P. By-pass PRDS.
10.	Warm up line for HP By-pass	: Between MS line and H.P. By-pass line.
11.	Hot Reheat lines	: Between Reheater and I.P turbine.
12.	HR equalising line	: Between LHS and RHS Hot Reheat lines.
13.	LP By-pass line	: Between HR line and condenser.
14.	Warm up line for LP By-pass	: Between LP By-pass line and HR line.
15.	CEP Suction line	: Between condenser hot well and CEP.
16.	Main condensate line	: Between CEP outlet and Deaerator, through GSC, CPU, DC, L.P. heaters.
17.	CEP Minimum Recirculation	: Between main condensate line after CEP to



**WBPDCCL**

**EPC Bid Document  
Sagardighi Thermal Power Project  
1x660 MW Unit No. 5, Phase - III**

	line	:	condenser.
18.	GSC Minimum Recirculation line	:	Between main condensate line after GSC to condenser.
19.	Deaerator filling line	:	Between Condensate Transfer pump discharge and deaerator.
20.	Boiler filling line	:	Between Condensate Transfer pump discharge and Boiler bottom ring header / economiser inlet.
21.	Fill up and Emergency	:	From Condensate Transfer pump discharge to make-up to condenser.
22.	DMCW make-up tank	:	From Cycle make-up pump discharge to DMCW make-up tank.
23.	Gravity Make-up to condenser	:	From condensate storage tank to condenser.
24.	Condensate Dump Line	:	Between M.C. line after GSC and condensate storage tank.
25.	Cycle make-up (DMSW) Pump Recirculation	:	Between Cycle make-up pump discharge header and suction header.
26.	Cycle make-up (DMSW) Pump Suction Line	:	From condensate storage tanks to Cycle make-up pump suction header.
27.	By-pass line	:	For all control valves
28.	By-pass lines for heaters	:	GSC, LP Heaters and HP Heaters.
29.	CEP sealing line	:	Bidder's choice.
30.	All extractions from main condensate line	:	For : <ul style="list-style-type: none"> <li>a) Exhaust Hood spray.</li> <li>b) Turbine Flash Tank spray.</li> <li>c) L.P. By-pass spray.</li> <li>d) Water sealing of valves.</li> <li>e) Vacuum breaker line sealing.</li> <li>f) CEP sealing.</li> <li>g) Analytical measurements.</li> </ul>



**WBPDCCL**

**EPC Bid Document  
Sagardighi Thermal Power Project  
1x660 MW Unit No. 5, Phase - III**

- |     |   |   |   |
|-----|---|---|---|
|     |   |   | h) Alkali flushing.   |
|     |   |   | i) Spray water to GSC desuperheater.  |
|     |   |   | j) Sampling.  |
|     |   |   | k) Instrument seal pot.   |
|     |   |   | l) Water sealing of valves & water<br>Washing of BFP Turbine.   |
|     |   |   | m) Make up to Vacuum Pumps.   |
|     |   |   | n) Spares.  |
| 31. | Turbine flash tank<br>drain and vent line   | : | From turbine Flash Tank drains to condenser hot<br>well.<br><br>From flash vessels vent to condenser steam<br>space.  |
| 32. | BFP Suction line                            | : | Between Deaerator and BFP suction.  |
| 33. | Main Feed Water<br>Feed Line                | : | From BFP discharge through HP heaters, control<br>station up to economiser inlet header.  |
| 34. | Steam turbine drive for BFP                 | : | Associated piping.  |
| 35. | Inlet line to attemperation<br>water header | : | From main feed water line to attemperation water<br>header.   |
| 36. | Extraction from BFP                         | : | From BFP suction to sample cooler suction, BFP<br>worm up and balance Leak-off line.  |
| 37. | All extraction from<br>Main Feed Water line | : | a) To Auxiliary Steam pressure<br>reducing desuperheating station.<br><br>b) Stub for alkali flushing.<br><br>c) HP By-pass spray.<br><br>d) Blind Stub.<br><br>e) Minimum recirculation lines. |
| 38. | Extraction lines                            | : | From various stage of turbine / CRH to L.P.<br>Heaters, H.P. heaters, Deaerator and BFP<br>Turbines.  |
| 39. | All vents of H.P and<br>L.P. heaters        | : | a) L.P. Heater vents to Condenser.  |



**WBPDCCL**

**EPC Bid Document**  
**Sagardighi Thermal Power Project**  
**1x660 MW Unit No. 5, Phase - III**

- |     |  |   |    |   |
|-----|--|---|----|---|
|     |  |   | b) | H.P. Heater vents to Deaerator / condenser.                           |
| 40. | All cascade drain connection between heaters | : | a) | From each HP Heater to next lower pressure HP Heater.                 |
|     |  |   | b) | The lowest pressure H.P. Heater to Dearator.                          |
|     |  |   | c) | From each L.P. Heater to next lower pressure L.P. heater              |
|     |  |   | d) | The lowest pressure L.P. heater to flash vessel through drain cooler. |
| 41. | All Drip connections to Flash Tanks          | : | a) | From all HP heaters.  |
|     |  |   | b) | All LP Heaters (except the Lowest Pressure LP Heater)                 |
|     |  |   | c) | From Gland Steam Condenser (GSC).                                     |
| 42. | Air Steam mixture line from turbine Glands   | : | a) | To GSC.   |
|     |  |   | b) | To Atmosphere.  |
| 43. | Vapour extraction line for GSC               | : |    | From GSC through vapour extractors to atmosphere.                     |
| 44. | By pass Line to GSC                          | : |    | Through desuperheater to atmosphere.                                  |
| 45. | Air steam mixture line from condenser        | : |    | To vacuum pumps.  |
| 46. | Drip connections to Deaerator:               |   |    | From H.P. Heaters.  |
| 47. | Connections for air outlet from vacuum pump  | : |    | For vacuum pumps to atmosphere.                                       |
| 48. | Steam connection to Auxiliary steam header   | : |    | From final superheater outlet.  |
| 49. | High Temperature Auxiliary Steam Header      | : |    | One for the unit with interconnection to phase - II.                  |
| 50. | Auxiliary Steam from High Temperature Header | : | a) | To Gland steam pressure reducing unit                                 |
|     |  |   | b) | For mill inerting (if required).                                      |





**WBPDCCL**

**EPC Bid Document  
Sagardighi Thermal Power Project  
1x660 MW Unit No. 5, Phase - III**

- c) For soot blowing.
- d) For BFP drive turbine.
- 51. Low Temperature Auxiliary Steam Header : One for the unit with interconnection to Phase – II
- 52. Auxiliary Steam from Low Temperature Header :
  - a) For Deaerator pegging
  - b) For atomising
- 53. Extraction line from CRH line : From CRH line to auxiliary steam header.
- 54. Condensate surge tank outlet : From condensate surge tank to line condenser hotwell.

- Note :**
- 1. Steam Blowing pipelines including target plates for MS, HR and CR lines etc. shall be included.
  - 2. Chemical cleaning pipelines shall be included.
  - 3. For scope of auxiliary steam line to new HFO heater, HFO pressurizing suction and discharge piping within Fuel oil Pressurizing pump house, please refer tender drawing no. 12A05-DWG-M-001N. Similarly, for scope of HFO & LDO piping in boiler island, the same drawing can be referred.



**WBPDCCL**

**EPC Bid Document**  
**Sagardighi Thermal Power Project**  
**1x660 MW Unit No. 5, Phase - III**

**Annexure-II****MATERIALS OF CONSTRUCTION FOR PIPING & FITTINGS**

Materials used in piping, fittings & specialties shall be as stipulated in the IBR and various codes as specified. However, the following basic guidelines shall in any case be followed for pipe materials:

<b>Service</b>	<b>Material, Equivalent/Superior to</b>
i) Temp. Up to 410°C	Carbon Steel, ASTM A-106, Gr. B or C Seamless. ASTM A-105/ A-234 WPB/WPC.
ii) Temp. Above 410 °C to 510 °C	Alloy Steel, ASTM A-335,P11. ASTM A-182 F11; A-234 WP11.
iii) Temp. Above 510°C to 540°C	Alloy Steel, ASTM A-335, P22/P91, ASTM A-182 F22/F91; A-234 WP22/91.
iv) Temp. Above 540 °C to 600°C	Alloy Steel, ASTM A-335, P91/ P92 or ASTM A-182 F91/F-92; A-234 WP91/92.
v) Temperature above 600°C	Austenitic stainless steel, Super 304H, TP 347H.  For Corrosive application – Rubber-lined Stainless Steel / Stainless Steel to 304L, 316L or approved equivalent.



**WBPDCCL**

**EPC Bid Document**  
**Sagardighi Thermal Power Project**  
**1x660 MW Unit No. 5, Phase - III**

**Annexure-III****MATERIALS OF CONSTRUCTION FOR VALVES**

Materials for Valves shall be equivalent/superior to the following, for non-corrosive services:

Working Class	Valves Size	Material	
		Body Bonnet Cover	Stem Hinge Pin
i) Temp. Up to 410°C	65 mm & above	ASTM A-216, Gr. WCBWCC	13% Cr. Steel (ASTM A-182, Gr. F6a)- min. hardness 200 HB
	50 mm & below	ASTM A-105	ASTM A-182, Gr. F6a - min. hardness 200 HB
ii) Temp. Above 410 °C to 510°C	65 mm & above	ASTM A-217, Gr. WC6	- Do -
	50 mm & below	ASTM A-182, Gr. F11	- Do --
iii) Temp. Above 510 °C to 540 °C	65 mm & above	ASTM A-217, Gr. WC9	
	50 mm & below	ASTM A-182, Gr. F22	
iv) Temp. above 540 °C to 600 °C	65 mm & above	ASTM A-217, Gr. WC/C12	
	50 mm & below	ASTM A-182, Gr. F91/F92	

**Note** : Non-return valves in corrosion service shall be swing check type, suitably lined.



**WBPDCCL**

**EPC Bid Document**  
**Sagardighi Thermal Power Project**  
**1x660 MW Unit No. 5, Phase - III**

**Annexure-IV**

### MATERIALS OF CONSTRUCTION FOR CONTROL VALVES

Materials for Control Valves shall be equivalent/superior to the following:

Sl. No.	Service	Body Material	Trim Material
1	Non-corrosive, non-flashing and non-cavitation service below 275°C. like Aux. steam flow to deaerator, Condensate flow to deaerator, CRH flow to deaerator etc.	Compatible with piping material	SS-316 with stellite faced guide posts and bushings.
2	Severe flashing/cavitation services like HP Heaters and LP Heaters, emergency drain, Deaerator overflow drain to hotwell etc.	Alloy steel as per ASTM A 217 Gr. WC9	400 series SS or equivalent to suit the specific requirement
3	Low flashing/ cavitation service like HP Heater/ LP Heater normal drains level control, GSC minimum flow, Gland seal steam pressure control valve etc.	Alloy steel as per ASTM A 217 Gr. WC6	400 series SS or equivalent to suit the specific requirement
4	Condensate service below 300°C. like condensate normal and emergency make-up control, DMCW DP control	SS-316	SS-316

**Note :** Valve body rating shall meet the process pressure and temperature requirements as per ANSI B16.34.





**WBPDC**

**EPC Bid Document  
Sagardighi Thermal Power Project  
1x660 MW Unit No. 5, Phase - III**

**VOLUME: II-J1**

**SECTION: VI**

**TECHNICAL SPECIFICATION  
FOR  
LOW PRESSURE PIPING, VALVES AND SPECIALTIES**



**Development Consultants Pvt. Ltd.**

**Volume: II-J1  
Section: VI  
Low Pressure Piping, Valves**



**WBPDC**

**EPC Bid Document  
Sagardighi Thermal Power Project  
1x660 MW Unit No. 5, Phase - III**

## CONTENTS

<b>CLAUSE NO.</b>	<b>DESCRIPTION</b>	<b>PAGE NO.</b>
1.00.00	GENERAL INFORMATION	1
2.00.00	CODES AND STANDARDS	2
3.00.00	SCOPE OF WORK	3
4.00.00	GENERAL DESIGN AND CONSTRUCTION	5
5.00.00	BROAD GUIDELINES FOR ERECTION AND INSTALLATION OF L.P. PIPING	12
6.00.00	DRAWINGS, DATA, INFORMATION & MANUALS	13
 <b>ATTACHMENTS</b>  		
ANNEXURE-I	SPECIFICATION OF PIPES FOR DIFFERENT SERVICES	15
ANNEXURE-II	SERVICE OF VARIOUS CATEGORIES OF VALVES	18
ANNEXURE-III	SPECIFICATION OF VALVES	19



**WBPDC**

**EPC Bid Document**  
**Sagardighi Thermal Power Project**  
**1x660 MW Unit No. 5, Phase - III**

## **SECTION-VI**

### **LOW PRESSURE PIPING, VALVES AND SPECIALTIES**

#### **1.00.00 GENERAL INFORMATION**

This section covers all the low-pressure piping up to 400mm NB size, associated valves and specialties that include but is not limited to the following systems.

- 1.01.00 Service Air System - shall consist of distributions terminated at hose valves for general house-keeping on the different floors of Power House Building, boiler floors, mill reject system and other auxiliary buildings of Main Plant. Distribution scheme shall also include some continuous and intermittent requirement of boiler and Turbine-generator islands and other BOP area buildings such as CW-ACW pump house, Vacuum pump house, CW treatment building, FGD & SCR areas. Both service air and instrument air will be supplied from the existing compressor house, where new compressors of Phase-III shall be installed.
- 1.02.00 Instrument Air System - shall comprise of distribution of instrument quality air to pneumatically operated instruments/ valves/dampers of the Main Power House Building, boiler, mill reject system and other auxiliary buildings inside plant area.
- 1.03.00 Demineralised Water -supply system including hot well make-up water piping from condensate storage tank, suction to different pumps and distribution to different consumption points.
- 1.04.00 Demineralised Water closed cycle cooling system.
- 1.05.00 Service water (clarified quality) - including supply to overhead Service Water (SW) tank in Power house from Tie-in-Point near unit#4 power house building and from tank to different distribution points of the Main Power house and other auxiliary buildings.
- 1.06.00 Potable water system (filtered & chlorinated water) including supply to overhead potable tank of Power House building, from Tie-in-Point near unit#4 power house building and from tank to different distribution points of the Power House Building and other auxiliary buildings.
- 1.07.00 Air Preheater wash water system including supply of Clarified water from Tie-in-Point near unit #4 to APH wash point of Unit #5, Phase-III and one pipe line (250 NB) from existing APH wash pump discharge header in clarified water pump house in PT area of Phase-I to enable operation of both existing APH wash pumps. This pipe shall be run on existing pipe rack.



**WBPDC**

**EPC Bid Document**  
**Sagardighi Thermal Power Project**  
**1x660 MW Unit No. 5, Phase - III**

- 1.08.00 Any other low pressure piping as found necessary during detail engineering shall also be included.
- 2.00.00 **CODES AND STANDARDS**
- 2.01.00 In addition to the requirements spelt out in Volume IIA, the design, manufacture, inspection and testing of the piping, fittings, valves and specialties covered under this specification shall conform, in general, to the standards and codes (latest edition) mentioned below:
- 2.01.01 IS-1239 : Mild steel tubes, tubular and other wrought steel fittings.  
[Part-I & II]
- 2.01.02 IS-3589 : Electrically welded steel pipes for water, gas and sewage (150 to 2000 mm nominal diameter)
- 2.01.03 IS-554 : Dimensions for pipe threads where pressure tight joints are required on the threads.
- 2.01.04 IS-1363 : Hexagonal head bolts, screws and nuts (size range M5  
[Part-I & II] M36)
- 2.01.05 IS-1364 : Precision and Semi-precision hexagon bolts, screws, nuts and lock nuts (diameter range 6 to 39 mm)
- 2.01.06 IS-3138 : Hexagon bolts & nuts (M42 to M150)
- 2.01.07 IS-5312 : Swing check type reflux (non-return) valves.
- 2.01.08 IS-2379 : Colour code for the identification of pipelines.
- 2.01.09 IS-2016 : Plain washers
- 2.01.10 IS-2712 : Compressed asbestos fibre jointing
- 2.01.11 ANSI B-16.5 : Steel pipe flanges and flanged fittings
- 2.01.12 ANSI B-16.9 : Wrought steel Butt welding flanged
- 2.01.13 ANSI B-16.11 : Forged steel fittings, Socket-welding and Threaded.  
ANSI B-36.10 : Steel pipes thickness
- 2.01.14 API-600 : Steel gate valves
- 2.01.15 BS-2633 : Class I Arc welding of ferrite steel pipe work for carrying fluids.
- 2.01.16 BS-534 : Specification for steel pipes and specials for water and sewage.
- 2.01.17 BS-5351 : Specification for Ball valves.





**WBPDC**

**EPC Bid Document  
Sagardighi Thermal Power Project  
1x660 MW Unit No. 5, Phase - III**

- 2.01.18 AWWA-C-504 : Specification for Butterfly valves.
- 2.01.19 AWWA-C-208 : Dimension for fabricated steel water pipe fittings.
- 2.02.00 Other international codes and standards may also be offered by bidder. However, same may be subject to acceptance by the Purchaser.
- 3.00.00 **SCOPE OF WORK**
- 3.01.00 The equipment and materials to be supplied shall include but not be limited to the following:
- a) Supply of all low pressure piping including bends, elbows, tees, branches, laterals, crosses, reducing union, couplings, caps, saddles, shoes, flanges, blank flanges, Y-pieces etc. as required for the piping system under the scope of this section.
  - b) Matching pipes, matching pieces like reducers/enlargers etc., counter flanges with bolts, nuts, washers, temporary and permanent gaskets, threaded union etc.
  - c) Supply and machining work of flanges, pipe spools and matching pipes to connect flow measuring orifices/nozzles with the main pipe work.
  - d) All isolating and regulating valves, non-return valves, steam/air traps, relief/safety valves (wherever applicable), strainers, pressure reducing orifices etc. complete with the counter flanges and matching connecting pieces as required within the entire low pressure piping system.
  - e) Anchors, hangers and supports, etc. as required. Any platform necessary for maintenance and operation of valve and equipment located 1.5 m above any permanent floor or platform including access ladders, supporting structures etc.
  - f) All secondary structural steel members required for pipe supports from building steel structures and from embedded steel wherever provided including pipe supports in trenches. However, trench piping should be avoided to the extent possible.
  - g) Funnels, tundishes for drips and drains including all miscellaneous drain piping and drain piping from tundish outlet up to drain points. All drain and vent lines shall be conveniently terminated to floor drain points/permanent drain trenches.
  - h) Flanges, counter flanges, blank flanges, bolts, nuts, washers, temporary and permanent gaskets, fasteners caps etc. as required for interconnecting piping, valves & fittings.





**WBPDCCL**

**EPC Bid Document  
Sagardighi Thermal Power Project  
1x660 MW Unit No. 5, Phase - III**

- i) Cleaning and Painting of all piping, valves & specialties at manufacturer's shop.

3.02.00 Following general requirements shall however be provided:

- a) Instrument Connections including instruments, root valves, sensing lines etc.
- b) Pipe stubs and blanking plates etc. required for chemical cleaning and hydro testing.

For conducting acceptance test, the required pressure, temperature, flow measurement points shall be provided.

3.03.00 All miscellaneous instruments as per approved P &ID during detail engineering stage.

3.04.00 **Tie-in Points with Phase-II**

Tie-in points for different systems will be as indicated below:

**i) DM Water Transfer System**

DM Water Transfer pump discharge line, capable of feeding both Phase-II & Phase-III is extended upto Condensate Storage tanks (CST) of unit #3 & #4 of Phase-II. The discharge line is terminated with an isolation valve. Suitable extension of piping from this tie-in point to inlet of CST of Phase-III will be done.

**ii) Potable Water System**

Potable water pump discharge line, capable of feeding both Phase-II & Phase-III is extended upto Potable water storage tanks on power house of unit #4 of Phase-II. The discharge line is terminated with an isolation valve. Suitable extension of piping from this tie-in point to the inlet of potable water storage tank of Phase-III will be done.

**iii) Service Water System**

Service water pump discharge line, capable of feeding both Phase-II & Phase-III is extended upto Service water storage tanks on power house of unit #4 of Phase-II. The discharge line is terminated with an isolation valve. Suitable extension of piping from this tie-in point to the inlet of service water storage tank of Phase-III will be done.

**iv) APH wash System**

APH Wash pump discharge line, is extended upto Air pre-heater of unit #4. The discharge line is terminated with an isolation valve. Suitable extension of piping from this tie-in point to be done upto APH of Phase-III. Another extension pipe line (250 NB) from existing APH



**WBPDC**

**EPC Bid Document**  
**Sagardighi Thermal Power Project**  
**1x660 MW Unit No. 5, Phase - III**

wash pump discharge header in clarified water pump house in PT area of Phase-I to APH of Phase-III to be implemented.

**v) Instrument Air System**

Instrument air line of Phase-III shall be interconnected with instrument air header of Phase-II near existing plant air compressor house. Further, IA ring header of Phase-III power house shall have interconnection with that of power house Phase-II.

**vi) Service Air System**

Service air line of Phase-III shall be interconnected with service air header of Phase-II near existing plant air compressor house. Further, SA ring header of Phase-III power house shall have interconnection with that of power house Phase-II.

**vii) Cooling water supply & return lines**

DMCCW supply and return header of Phase-II inside compressor house shall be extended to cater the cooling water requirement of IA & SA compressors and dryers of phase-III.

**4.00.00 GENERAL DESIGN AND CONSTRUCTION**

**4.01.00 General Considerations**

4.01.01 The piping systems included in this section shall be designed to operate continuously without replacement during the plant service life of 30 years.

4.01.02 The piping system shall be complete in every respect and in accordance with the highest standard of workmanship. Any item of the section on which the bidder is in doubt shall be referred to the Owner for clarification.

4.01.03 All design and fabrication shall be in accordance with codes/standards specified.

4.01.04 No pipe work shall be run in trenches carrying electrical cables.

4.01.05 Pipe size above 50 NB shall be shop fabricated and of size 50 NB and below shall be field run.

4.01.06 All piping shall be identified by means of colour strips and by adequate lettering, conveniently spaced and located. Identification colours and lettering shall be as approved.

4.01.07 Air release and drain branches shall be provided wherever necessary depending upon the layout and arrangement so that the drains and air release valves are located for easy operation.



**WBPDC**

**EPC Bid Document**  
**Sagardighi Thermal Power Project**  
**1x660 MW Unit No. 5, Phase - III**

4.01.08 Unless otherwise specified, all pipe work shall be suitable for a minimum pressure of 10.0 kg/sq. cm(g) at 80 deg. C or as required by the design of the different piping system, if higher.

4.01.09 **Drain Pipe Work**

- a) Low pressure drains shall have an isolating valve at the point of take-off from the pipe or vessel to be drained, or as near as possible for conventional operation.
- b) Unless otherwise stated, all drain piping shall be of 25 mm NB minimum and all vent pipings shall be of 15 mm NB size minimum. For pipes up to 50mm NB, pipe wall thickness shall be as per schedule 80 of ANSI B36.10.
- c) Unless otherwise stated, wherever a main or branch of any pipeline is terminated with a valve, such terminal valve shall be provided with a blank flange/blanking cap at the free end.

4.01.10 Specification of pipes used in different services included in the L.P piping section has been detailed in Annexure-I.

4.02.00 **Material Specification**

4.02.01 Materials for pipes and fittings shall be as stipulated in Annexure-I. In case bidder wants to offer alternative piping material, same may be accepted by the Purchaser depending on the merits of alternative material.

4.02.02 Pipe attachments for supports, anchors and restraints, which are coming in direct contact with pipes, shall have similar materials as the piping concerned. All other materials of supports, anchors and restraints shall be of tested quality and as per manufacturer's standards.

4.03.00 **Fabrication**

All pipes above 50 NB shall have butt-welded connections as per ANSI B 16.25 with a minimum of flanged joints necessary for maintenance. Piping of sizes 50 NB and below shall have socket welded connections as per ANSI B 16.11. Where flanges are adjacent to welded fittings, weld neck flanges shall be used.

Branches shall, in general, be formed by welding. Standard fittings may be used in positions and for sizes where approval has been given in detail drawings. Pipe bends and tees shall be truly cylindrical and of uniform section. all welded branches shall be reinforced where needed as per the applicable codes/regulations.

4.03.01 Piping shall be fabricated in the shop in the largest transportable sections to minimize the number of field weld joints. The choice of field weld joints locations shall be based on the traverse of the pipe through walls, floors,



**WBPDC**

**EPC Bid Document**  
**Sagardighi Thermal Power Project**  
**1x660 MW Unit No. 5, Phase - III**

sleeves or other restrictive areas. Support attachments for major piping shall be done at shop.

- 4.03.02 All pipes bends shall be made true to angle with no negative tolerance and shall have a smooth surface free of flat spots, crease and corrugations. A cross section through any bent portion of the pipe shall be true in diameter, within plus or minus 3% of the pipe diameter. Pipe bends shall be made from straight pipe pieces of sufficiently higher thickness so that after thinning, the minimum thickness of bends shall not be less than the minimum thickness required for the straight pipe. Thinning allowance shall be considered as per the relevant code.
- 4.03.03 For bends in pipes straight piece of pipes shall be bent by the bidder to required bend radius. However, forged bends (Bend radius = 1.5 x pipe diameter) wherever required shall be provided.
- 4.03.04 The ends of Pipe and welded fittings shall be bevelled according to details shown in the relevant piping code. All welding shall be made in such a manner that complete fusion and penetration are obtained without an excessive amount of filler metal beyond root area. The reinforcement shall be applied in such a manner that it shall have a smooth contour merging gradually with the surface of adjacent pipe and welded fittings. Backing rings shall not be used on any pipe welds, unless otherwise approved by the Engineer.
- 4.03.05 **Cutting and Beveling**
- a) Carbon steel piping - End preparation for butt welding shall be done by machining/flame cutting.
- 4.04.00 **Hangers, Supports, Anchors**
- Normally pipe supports and anchors shall be selected at those points in the buildings where provision has been made for the loads imposed. The cutting of floor/roof beams or the reinforcement in slabs will not be permitted. Piping attached to a plant item shall be supported in such a way that the weight of the piping is not taken by the plant item.
- 4.04.01 Support spacing shall be as per good engineering practice. However in no case it shall be less than support spacing stipulated in ANSI B31.1.
- 4.04.02 Accurate weight balance calculations shall be made to determine the required supporting force at each hanger location and the pipe weight load at each equipment connection.
- 4.04.03 All large pipes and all long pipes shall have at least two supports each arranged so that any length of pipe or valve may be removed without any additional supports being required.
- 4.04.04 Support steel shall be of structural quality. Perforated strap, wire or chain shall not be used. Support components shall be connected to support steel by



**WBPDC**

**EPC Bid Document  
Sagardighi Thermal Power Project  
1x660 MW Unit No. 5, Phase - III**

welding, by bolting or by beam clamps. Bolt holes shall be drilled not burned. Support components may be bolted to concrete using approved concrete anchors.

#### 4.05.00 **Valves and Accessories**

##### 4.05.01 General Requirements

- a) All valves shall be of approved make and type and shall have cast/forged bodies with covers and glands of approved construction and materials as specified in Annexure II & III. The valves shall be provided with electric motors/solenoids and actuators as required.
- b) Valves and specialties to be supplied under this specification will be used for various air and water services and will be located indoor/outdoor and on horizontal/vertical runs of the pipelines. However, mounting of valves in vertical pipe runs should be avoided as far as possible.
- c) All valves shall, unless otherwise stated, have the internal diameter same/as the internal diameter of the pipes to be joined.
- d) All valves shall receive tests at manufacturer's or bidder's works in accordance with the specific requirements of the approved Codes of Practice. Valves shall be rising stem or otherwise as approved by the Purchaser.
- e) Gate valve and Ball valve have been specified with the intention of achieving isolation and tight shut-off. In full open condition, these valves should offer minimum of resistance to fluid flow.
- f) Globe valves have been specified with the intention of achieving good control of fluid passing. The plug and seat will have therefore suitable profiles for obtaining such controlling action.
- g) Check valves have been specified in order to prevent reverse flow through them.
- h) All valves shall function smoothly without sticking, rubbing or vibration on opening or closing and shall be suitable for most stringent service conditions i.e. flow, temperature and pressure under which they may be required to operate.
- i) Material, design, manufacture, testing etc. for all valves and specialties along with the accessories shall conform to the latest editions of codes.
- j) By pass valves shall be provided for larger size valves as per standards followed and as felt necessary for smooth and easy operation, even though not specifically mentioned in the specification.





**WBPDCCL**

**EPC Bid Document  
Sagardighi Thermal Power Project  
1x660 MW Unit No. 5, Phase - III**

- k) All flanged valves and specialties to be supplied under this section shall be provided with two (2) counter flanges, bolts, nuts, washers, gaskets etc.
- l) All valves shall be of approved design and manufacture. Where valves are of similar size and type they shall be interchangeable with one another. Valves shall have welded or flanged connections subject to the Purchaser's approval.
- m) All valves shall have outside screwed spindles and screwed thread of spindle shall not pass through or into the stuffing box. Where valves are exposed to the weather, protective covers shall be provided for the spindles, which shall be subject to approval.
- n) Gate, Globe and Ball valves shall be provided with the following accessories in addition to other standard items:
  - i) Hand wheel with embossed open and shut directions.
  - ii) Local position indicator.
  - iii) Motorised operation as specified by Engineer.
- o) Gate valves, in addition shall be provided with following extra features
  - i) Bypass valve for valves of 300 mm size and above.
  - ii) Draining arrangement
  - iii) Enclosed Gear operators for valves 300 mm size and above for ease in operation.
  - iv) Motorised operation as specified by Engineer.
- p) All gate and globe valves shall be rising stem type.
- q) All valves shall be provided with hand-wheels, chain, operator, extended spindle and floor stand wherever required so that they can be operated manually by a single operator from the nearest operating floor either at a lower or higher elevation as the case may be. If such a valve is provided with integral bypass then similar arrangement shall be done for the bypass valve also.
- r) All valves and specialties shall be provided with brass Tag Discs indicating Tag numbers and nomenclature of the valve including duty or service intended and the function of the valves specialties.
- s) Stems shall preferably be arranged vertically with gland at the top, however, in no circumstances must the stem be inclined downward from horizontal or gland be at the bottom. Globe valves shall be installed with the pressure under the disc. Valves shall not be fitted in inverted position.



**WBPDC**

**EPC Bid Document**  
**Sagardighi Thermal Power Project**  
**1x660 MW Unit No. 5, Phase - III**

- t) Where necessary, for accessibility, grease nipples shall be fitted at the end of extension piping and where possible these shall be grouped together and mounted on a common panel situated at a convenient position. A separate nipple shall be provided to lubricate each point. The Bidder shall supply the first fill of oil or grease for these parts. The Bidder shall supply a suitable manually operated grease gun for the standard type of nipple provided.
- u) The spindles for all valves for use outside the building shall have weatherproof protection covers of approved construction.
- v) All valves shall be fitted with indicators so that it may be readily seen whether the valves are open or shut. In the case of those valves fitted with extended spindles, indicators shall be fitted both to the extended spindles and to the valve spindles.
- w) Plastic or bakelite valve hand wheels will not be accepted.
- x) All valves shall be closed by rotating the hand wheel in a clockwise direction when looking at the faces of the hand wheel. The face of each hand wheel shall be clearly marked with the words 'Open' and 'Shut' with arrows adjacent to indicate the direction of rotation to which each refers.
- y) Wherever practicable heavy valves of total weight including actuator, drive motor, integral by-pass etc., equal to or greater than 500 kg. shall be provided with suitable lugs to permit direct suspension by hanger rod or direct resting on bottom support, as applicable.
- z) Special attention shall be given to the operating mechanism for large size valves in order that quick and easy operation is obtained and maintenance is kept to a minimum.
- aa) Eyebolts shall be provided where necessary to facilitate handling heavy valves or parts of valves.
- bb) The Bidder shall supply with his bid and in addition during the course of the Contract, comprehensive drawings showing the design of valves, test pressure and working pressure/temperatures. They should include a parts list referring to the various materials used in the valve construction.
- cc) All sampling and root valves shall be of integral body bonnet type.

4.05.02 For Design Requirements for different valves refer Annexure-II & III.

4.06.00 **Safety/Relief Valves**

Safety/Relief valves shall be of direct spring loaded type and shall have a tight, positive and precision closing.





**WBPDC**

**EPC Bid Document  
Sagardighi Thermal Power Project  
1x660 MW Unit No. 5, Phase - III**

All safety valves shall be provided with manual lifting lever.

Valves used for air and any other compressive fluid shall be of pop type.

Safety/Relief valves shall be constructed and adjusted to permit the fluid to escape without increasing the pressure beyond 10% above the set blow off pressure. Valve shall reset at a pressure not less than 2.5% and more than 5% of the set pressure.

Releasing capacity of the safety/relief valves shall be as per the applicable codes and standards and shall be subject to the approval of the Engineer.

The seat and disk of safety valves shall be of suitable material to resist erosion. The seat of valve shall be fastened to the body of the valve in such a way that there is no possibility of the seat lifting.

**4.07.00 Hosepipe and Accessories**

4.07.01 Hose valves for service water system shall be Gate valves and service air system shall be Globe valves.

4.07.02 Hose pipes with fittings for Service Water System:

- a) The water hose shall be as per IS-444 (Type-3).
- b) Length of each hose shall be 15 metres.
- c) For each hose, one end shall be fitted with M.S. female coupling with swiveling nuts and soft seating ring suitable for connection to male end of hose valve and other end shall be made threaded for joining with the swiveling nut of a second hose whereby two hose lengths may be joined.

4.07.03 Hose pipes with fittings for Compressed air System:

- a) The compressed air hose shall be as per IS-911 (Type 2).
- b) The length and type of each end shall be similar to as specified in above clause no. (4.07.02) above.

**5.00.00 BROAD GUIDELINES FOR ERECTION AND INSTALLATION OF LP PIPING**

5.01.00 All fittings like "T" pieces, flanges, reducers etc. shall be suitably matched with pipes for welding. The valves will have to be checked, cleaned or overhauled in full or in part before erection, after chemical cleaning and during commissioning.

5.02.00 Adjustments like removal of oval ties in pipes and opening or closing the fabricated bends of high pressure piping to suit the layout shall be considered part of work and is required to carry out such work as per instruction of Owner,



**WBPDC**

**EPC Bid Document  
Sagardighi Thermal Power Project  
1x660 MW Unit No. 5, Phase - III**

which shall include specified heat-treatment procedures, etc. also wherever required.

- 5.03.00 Certain adjustments in length may be necessary while erecting high pressure pipelines and the bidder should remove the extra lengths to suit the final layout after preparing edges afresh and adopting specified heat treatment procedures.
- 5.04.00 Suspension for piping, pressure parts, etc., will be supplied in running lengths, which shall be cut to suitable sizes and adjusted as required.
- 5.05.00 All the valves, lifting equipments, actuators, power cylinders, etc., shall be serviced and lubricated to the satisfaction of Engineer before erecting the same and also during pre-commissioning. Even after commissioning, the equipments, if there are problems in the operation, they have to be attended to by the Bidder during the tenure of the contract. Welding or jointing of extension spindle for valves to suit the site conditions and operational facility shall be part of erection work.
- 5.06.00 All tubes and pipes shall be cleaned and blown with compressed air and shown to the engineer before lifting. Bigger size pipes should be cleaned with flexible wire brush, wherever necessary. After cleaning is over the end caps shall be put back in tube openings till such time they are welded to other tubes.
- 5.07.00 Fine fittings, drain piping, oil systems & other small bore piping have to be routed according to site conditions and hence shall be done only in position. As such, layout of small-bore piping shall be done as per site requirement. There is a possibility of slight change in routing the above pipelines even after completion of erection, which shall be carried out by the Bidder without any extra cost to the Purchaser. Work shall also include fabrication of small bends at site from straight lengths to suit the site conditions.
- 5.08.00 Welding of temporary supports, cleats, etc., on the building columns shall also be avoided. In case of absolute necessity, Erection bidder shall take prior approval from Bidder/Owner. Further, any cutting or alteration of member of the structure or platform or other equipments shall not be done without specific prior approval of Owner.
- 5.09.00 Wherever piping erected by the Erection Bidder is connected to piping or equipment erected by some other agencies the joint at the connecting point shall be considered under this specification.
- 5.10.00
- a) All piping shall be grouped wherever practicable and shall be routed to present a neat appearance.
  - b) The piping shall be arranged to provide clearance for the removal of equipment for maintenance and for easy access to valves, instruments and other piping accessories required for operational maintenance.





**WBPDC**

**EPC Bid Document  
Sagardighi Thermal Power Project  
1x660 MW Unit No. 5, Phase - III**

- c) Piping shall be routed above ground unless otherwise specifically indicated/ approved by the Owner. In such special case, the piping may be arranged in trenches, or buried and properly protected as per AWWA Standards.
- d) Overhead piping shall have a minimum overhead clearance of 4 meters above walkways and working areas and 6 meters above roadways unless otherwise approved by the Owner.
- e) Drains shall be provided at all low points and vents at high points as per actual layout regardless of whether some have been shown in respective Tenders drawings or not. The pipelines shall be sloped towards the drain points.

5.11.00 All drips and drains for piping and equipment whether shown in the Tender drawings or not shall terminate on the ground floor up to station drain unless otherwise specified. Leading such drains up to station drainage is also the responsibility of the Bidder.

6.00.00 **DRAWINGS, DATA, INFORMATION & MANUALS**

6.01.00 Drawings, data, Information to be furnished by the Bidder besides those already mentioned in volume : IIA with the offer.

6.01.01 A complete list of all piping and fittings of various sizes with their quantities and details e.g. nominal size, O.D., I.D. (as applicable) thickness, design pressure, design temperature, material of construction/code/standards etc.

6.01.02 A complete list of all valves with their type, quantities & ratings.

6.01.03 Manufacturer's catalogue indicating complete range of available size and rating of pipes & fittings.

6.01.04 Descriptive literature on the manufacturing process and quality control procedures highlighting the manufacturing, fabricating and testing facilities available in the shop.

6.02.00 **After Award of Contract**

Detail drawings including fabrication drawings of all shop fabricated piping system indicating design parameters and complete bill of material (Relevant Standards and grades to be indicated) and information/data pertaining to the hydrostatic and non-destructive test requirements to be submitted progressively.

6.02.01 Detail dimensioned drawing of each valve, specialties, indicating tag no., pressure rating, manufacturing standard, the bill of materials and hydrostatic test pressures. The drawing shall include the end preparation details and shall indicate the position of the hand wheel/operator. Technical particulars of motor operators wherever applicable shall also be indicated.





**WBPDC**

**EPC Bid Document  
Sagardighi Thermal Power Project  
1x660 MW Unit No. 5, Phase - III**

- 6.02.02 General arrangement drawing for each hanger/support/anchor etc. indicating identification number, auxiliary supporting structural details, other details & information as required in the specification.
- 6.02.03 Wiring diagram for all limit switches of motor operated valves.
- 6.02.04 The loading data required for design of structures shall be furnished well in advance to suit Purchaser's time schedule.





WBPDCCL

EPC Bid Document  
Sagardighi Thermal Power Project  
1x660 MW Unit No. 5, Phase - III

## ANNEXURE-I

## SPECIFICATION OF PIPES FOR DIFFERENT SERVICES

	A		B		C	D
<b>Services</b>	<b>1. Clarified Water piping</b>		<b>1. Drinking/ Potable Water Supply, piping (Clarified water, chlorinated)</b>		<b>1. Demineralised Water, DMCW piping, Service and Instrument Air Piping less than and equal to 50 NB</b>	<b>1. Demineralised Water, 2. DMCW piping, Service and Instrument air piping for sizes equal to greater than 65 NB</b>
1.00.00 Material of Pipe	Carbon Steel IS-1239 Heavy Grade upto 150 NB and IS-3589 for sizes above 150 NB with minimum pipe thickness of 6 mm.		Carbon Steel as per IS-1239 Heavy Grade for sizes upto 150 NB and IS-3589 for sizes above 150 NB with minimum pipe thickness of 6 mm. The pipes shall be galvanized as per IS-4736		Stainless Steel as per ASTM A-312 Gr. 304. Thickness- as per schedule 40S, ANSI B36.19	Stainless Steel as per ASTM A-312 Gr. 304. Thickness- as per schedule 10S, as per ANSI B36.19
2.00.00 Construction	ERW / Seamless		ERW / Seamless		Seamless	ERW
3.00.00 Joints	Slip-on Flange and butt weld for size 65 NB and above and Socket weld joint for size 50 NB and below.		Screwed flange for sizes 65 NB and above and screwed for size 50 NB and below. Pipe to pipe joint shall be with union as per IS:1239, Part-II.		Socket welded for size 50 NB and below	Slip-on flange and butt weld joint.
4.00.00 Fittings	Pipe Sizes > = 65 NB	Pipe Sizes < = 50 NB	Pipe Sizes > = 65 NB	Pipe Sizes < = 50 NB		



Development Consultants Pvt. Ltd.

Page 15 of 21

Volume: II-J1  
Section: VI  
Low Pressure Piping, Valves



WBPDCCL

EPC Bid Document  
Sagardighi Thermal Power Project  
1x660 MW Unit No. 5, Phase - III

	A		B		C	D
<b>Services</b>	<b>1. Clarified Water piping</b>		<b>1. Drinking/ Potable Water Supply, piping (Clarified water, chlorinated)</b>		<b>1. Demineralised Water, DMCW piping, Service and Instrument Air Piping less than and equal to 50 NB</b>	<b>1. Demineralised Water, 2. DMCW piping, Service and Instrument air piping for sizes equal to greater than 65 NB</b>
4.01.00 Materials	ASTM-A-234 Gr. WPB	ASTM-A-105	ASTM-A-234 Gr. WPB galvanized as per IS-4736	ASTM-A-105 galvanised as per IS-4736	ASTM-A-182 F304	ASTM-A-351-CF8 or ASTM-A-403 WP304
4.02.00 Construction	Welded/ Seamless	Forged	Welded/ Seamless	Forged	Forged	Welded/Seamless
4.03.00 Standard	ANSI-B-16.9 for Butt welding fittings and fabricated fitting AWWA-C- 208	ANSI-B-16.11 or IS:1239, Part-II	ANSI-B-16.9	ANSI-B-16.11 or IS:1239, Part-II	ANSI-B-16.11	ANSI-B-16.9
4.04.00 End details	Pipe size >=65 NB Bevel ended as per ANSI-	Pipe size <=50 NB Socket welded as per ANSI-B-	Pipe size >=65 NB Screwed Flanged	Sizes <=50 NB Screwed socketed as per ANSI-B-16.11.	Socket welded as per ANSI-B-16.11	Bevel ended as per ANSI- B-16.25



Development Consultants Pvt. Ltd.

Page 16 of 21

Volume: II-J1  
Section: VI  
Low Pressure Piping, Valves



**WBPDCCL**

**EPC Bid Document  
Sagardighi Thermal Power Project  
1x660 MW Unit No. 5, Phase - III**

	<b>A</b>		<b>B</b>		<b>C</b>	<b>D</b>
<b>Services</b>	<b>1. Clarified Water piping</b>		<b>1. Drinking/ Potable Water Supply, piping (Clarified water, chlorinated)</b>		<b>1. Demineralised Water, DMCW piping, Service and Instrument Air Piping less than and equal to 50 NB</b>	<b>1. Demineralised Water, 2. DMCW piping, Service and Instrument air piping for sizes equal to greater than 65 NB</b>
	B-16.25	16.11				
5.00.00 Flanges	150 lb (min) class as per ANSI-B-16.5 complete with nuts, bolts and gaskets		As per ANSI-B-16.5 pressure class 150lbs (min) - galvanised-complete with nuts, bolts and gaskets.		As per ANSI-B-16.5 pressure class 150lb (min) complete with nuts, bolts and gaskets. Material as per class 4.01.00.	150lb (min) class, flat face, as per ANSI-B-16.5 complete with nuts, bolts and gaskets.
Pipes which fall under IS:1239 shall be hydrostatically tested according to the said code, for others refer Vol.: II-A.						



Development Consultants Pvt. Ltd.

Page 17 of 21

**Volume: II-J1  
Section: VI  
Low Pressure Piping, Valves**

**WBPDC**

**EPC Bid Document**  
**Sagardighi Thermal Power Project**  
**1x660 MW Unit No. 5, Phase - III**

**ANNEXURE-II****SERVICES OF VARIOUS CATEGORIES OF VALVES**

<b>Valve Classification</b>		<b>Service</b>	
A.	Cast iron body Gate/Globe/Check Valve	i) Service Water ii) Clarified Water iii) Drinking/ Potable Water	For sizes 65 NB and above.
B.	Stainless steel body/ Gate/Globe /Check/Ball Valve	i) For Demineralised water ii) Service and Instrument Air iii) Inhibited Demineralised Water	For all sizes For all sizes. Ball valves to be used in air line. For all sizes
C.	Steel Body valves	i) Service Water ii) Clarified Water iii) Drinking/ Potable Water	For sizes less than and equal to 50 NB
D.	Cast Iron body butterfly valve	i) Service Water ii) Clarified Water iii) Filtered Water	For butterfly valve specification refer Annexure II, Sec.V of Vol. II-J1.





**WBPDCCL**

**EPC Bid Document  
Sagardighi Thermal Power Project  
1x660 MW Unit No. 5, Phase - III**

**ANNEXURE-III**

**SPECIFICATION OF VALVES**

		A. Cast Iron Body Gate/ Globe/Check Valve	B. Stainless steel Body Gate/Globe/Check/Ball Valve	C. Steel Body Gate/ Globe/Check Ball Valve
1.00.00	Valve Classification Code	CIGC	SSGC	STGC
2.00.00	Basic Design Code			
	a) Gate	a) i) IS 780 for 50 mm - 300 mm NB ii) IS2906 for 350 mm NB and above or as per MSS-SP-70	a, b, c) ANSI-B-16.34	i) API 600 for 50mm ii) API 602 for size
	b) Globe	b) MSS - SP - 85		b) BS-1873/ANSI-B-16.34
	c) Check	c) IS-5312/MSS - SP -71		c) BS-1868/ANSI B16.34
	d) Ball		d) BS-5351	
3.00.00	Pressure Class	To be suitably chosen considering the pressure requirement. Refer Clause No. 4.01.08 in this regard.		
4.00.00	Construction	Cast body and bonnet / cover	Forged body up to 50 NB	Forged body up to 50 NB and



Development Consultants Pvt. Ltd.



**WBPDCCL**

**EPC Bid Document  
Sagardighi Thermal Power Project  
1x660 MW Unit No. 5, Phase - III**

		A. Cast Iron Body Gate/ Globe/Check Valve	B. Stainless steel Body Gate/Globe/Check/Ball Valve	C. Steel Body Gate/ Globe/Check Valve/ Ball Valve
5.00.00	Material		and Cast body above that	Cast body above that
5.01.00	Body & Bonnet/ cover	IS 210 Gr. FG 260 or ASTM A216 Class B.	ASTM-A-182 F304 for Ball Valves: A351 CF8M for cast body, A 182 F304 for forged body.	ASTM-A-216 Gr. WCB for cast body & ASTM-A-105 for forged body
5.02.00	Trim / Disc.	IS-210 Gr. FG 260 or ASTM A216 Class B.	ASTM-A-182 F304 for Gate, Globe, Check valves and 351CF8M for Ball valves. For DKW system : ASTM-A-182 F6A (min. 250 HB)	13% Cr Steel as per ASTM-A-182 Gr. F6 heat treated and hardened (min 250 NB) for cast body and ASTM-A-105 Hard faced with Stellite (min 350 HB) for forged body
5.03.00	Seating surface	13% Cr steel as per IS 1570	For Ball valves PTFE seats and seals.	13% Cr. Steel as per ASTM-A-182 Gr. F6
6.00.00	End Preparation	Socket welded for size equal to and below 50 NB and flanged with counter flanges for 65 NB and above.		



Development Consultants Pvt. Ltd.

Page 20 of 21

**Volume: II-J1  
Section: VI  
Low Pressure Piping, Valves**



WBPDCCL

EPC Bid Document  
Sagardighi Thermal Power Project  
1x660 MW Unit No. 5, Phase - III

		A. Cast Iron Body Gate/ Globe/Check Valve	B. Stainless steel Body Gate/Globe/Check/Ball Valve	C. Steel Body Gate/ Globe/Check Ball Valve
7.00.00	Testing			
	a) Gate	i) As per IS - 780 for 50 mm - 300 mm NB ii) IS-2906 for sizes equal to and above 350 mm NB	As per ANSI B-16.34	API-598
	b) Globe	Hydrostatic Test as per MSS-SP-85		BS-1873
	c) Check	IS-5312/MSS-SP-71		BS--1868



Development Consultants Pvt. Ltd.

Page 21 of 21

Volume: II-J1  
Section: VI  
Low Pressure Piping, Valves



**TITLE:**  
**1 X 660 MW SAGARDIGHI TPS UNIT NO. 5**  
**PHASE III**

---

**TECHNICAL SPECIFICATION FOR**  
**CONDENSATE POLISHING UNIT**

SPECIFICATION NO. PE-TS-445-155A-A001

---

SECTION : II

---

**SUB-SECTION: IIA**

---

REV. NO. 02	DATE : 18.04.2022
-------------	-------------------

**TECHNICAL SPECIFICATION FOR**  
**HORIZONTAL CENTRIFUGAL PUMPS**

	<b>TITLE:</b>	SPECIFICATION NO. PE-TS-445-155A-A001	
	<b>1 X 660 MW SAGARDIGHI TPS UNIT NO. 5 PHASE III</b>	SECTION : II	
	<b>TECHNICAL SPECIFICATION FOR CONDENSATE POLISHING UNIT</b>	<b>SUB-SECTION: IIA</b>	
		<b>REV. NO. 02</b>	<b>DATE : 18.04.2022</b>

## 1.00.0 SCOPE

1.01.0 This specification covers the design, material, construction features, manufacture, inspection, testing the performance at the Vendor's/Sub-Vendor's Works and delivery to site of Horizontal Centrifugal Pumps.

## 2.00.00 CODES AND STANDARDS

2.01.0 The design, material, construction, manufacture inspection and performance testing of Horizontal Centrifugal Pumps shall comply with all currently applicable statutes, regulations and safety codes in the locality where the Equipment will be installed. Nothing in these specifications shall be construed to relieve the Vendor of this responsibility. The Equipment supplied shall comply with the latest applicable Indian Standards listed below. Other National Standards are acceptable, if they are established to be equal or superior to the Indian Standards.

2.02.0 List of Applicable Standards.

1	IS : 1520	Horizontal Centrifugal Pumps for clear cold fresh water.
2	IS : 5120	Technical requirements of roto dynamic special purpose pumps.
3	API : 610	Centrifugal pumps for general refinery service.
4	IS : 5639	Pumps Handling Chemicals & corrosion liquids.
5	IS : 5659	Pumps for process water.
6	HIS	Hydraulic Institute Standards, USA
7	ASTM-1-165-65	Standards Methods for Liquid Penetration Inspection.

2.03.03 In case of any contradiction with aforesaid standards and the stipulations as per the technical specifications as specified hereinafter the stipulations of the technical specifications shall prevail.

## 3.00.00 DESIGN REQUIREMENTS

3.01.00 The Pump shall be capable of developing the required total head at rated capacity for continuous operation. Also the pumps shall be capable of being operated to give satisfactory performance at any point on the HQ characteristics curve over the operating range of 40% to 120% of the duty point. The maximum efficiency of pump shall be preferably be within +/- 10% of the rated design flow as indicated in the data sheets.

3.02.00 The total head capacity curve shall be continuously rising from the operating point towards shut-off without any zone of instability and with a minimum shut-off head of 15% more than the design head.

3.03.00 Pumps of a particular category shall be identical and shall be suitable for parallel operation with equal load division. The head Vs capacity and BHP Vs capacity characteristics should match to

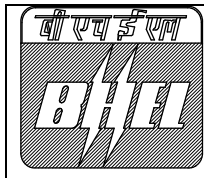

**TITLE:**  
**1 X 660 MW SAGARDIGHI TPS UNIT NO. 5**  
**PHASE III**

SPECIFICATION NO. PE-TS-445-155A-A001

SECTION : II

**TECHNICAL SPECIFICATION FOR**  
**CONDENSATE POLISHING UNIT**

**SUB-SECTION: IIA**

REV. NO. 02

DATE : 18.04.2022

ensure even load sharing and trouble free operation throughout the range. Components of identical pumps shall be interchangeable.

- 3.04.00 Pumps shall run smoothly without undue noise and vibration. Peak to peak vibration limits shall be restricted to the following values during operation:

SPEED	Antifriction Bearing	Sleeve Bearing
1500 rpm and below	75.0 micron	75.0 micron

- 3.05.00 The noise level shall not exceed 85 dBA. Overall sound pressure level reference 0.0002 microbar (the standard pressure reference for air sound measurement) at a distance of 1 M from the equipment.

- 3.06.00 The pumps shall be capable of starting with discharge valve fully open and close condition. Motors shall be selected to suit to the above requirements. Continuous Motor rating (at 50 deg.C ambient) shall be at least ten percent (10%) above the maximum load demand of the pump in the entire operating range to take care of the system frequency variation and no case less than the maximum power requirement at any condition of the entire characteristic curve of the pump.

- 3.07.00 The kW rating of the drive unit shall be based on continuously driving the connected equipment for the conditions specified. However, in cases where parallel operation of the pumps are specified, the actual motor rating is to be selected by the Bidder considering overloading of the pumps in the event of tripping of operating pump(s).

- 3.08.00 Pumps shall be so designed that pump impellers and other accessories of the pumps are not damaged due to flow reversal.

- 3.09.00 The Contractor under this specification shall assume full responsibility in the operation of pump and motor as a unit.

#### **4.00.0 DESIGN CONSTRUCTION**

- 4.01.00 Design and construction of various components of the pumps shall conform to the following general specifications for material of construction of the components, data sheets shall be referred to.

#### **4.02.0 Pump Casing**

- 4.02.01 Pump casing shall have axially or radially split type construction. The casing shall be designed to withstand the maximum shut-off pressure developed by the pump at the pumping temperature.

- 4.02.02 Pump casing shall be provided with a vent connection and piping with fittings & valves. Casing drain as required shall be provided complete with drain valves, piping and plugs. It shall be provided with a connection for suction and discharge pressure gauge as standard feature. It shall be structurally sound to provide housing for the pump assembly and shall be designed hydraulically to minimum radial load at part load operation.

#### **4.03.00 Impeller**

	<b>TITLE:</b> <b>1 X 660 MW SAGARDIGHI TPS UNIT NO. 5</b> <b>PHASE III</b>	SPECIFICATION NO. PE-TS-445-155A-A001	
		SECTION : II	
	<b>TECHNICAL SPECIFICATION FOR</b> <b>CONDENSATE POLISHING UNIT</b>	<b>SUB-SECTION: IIA</b>	
		<b>REV. NO. 02</b>	<b>DATE : 18.04.2022</b>

4.03.01 Impeller shall be closed, semi-closed or open type, and it shall be designed in conformance with the detailed analysis of the liquid being handled.

4.03.01 The impeller shall be secured to the shaft, and shall be retained against circumferential movement by keying, pinning or lock rings. On pumps with overhung shaft, impellers shall be secured to the shaft by a lockout or cap screw which tightness in the direction of normal rotation.

#### **4.04.00 Impeller/Casing Wearing Rings**

4.04.01 Replaceable type wearing rings shall be provided at suitable locations of pumps. Suitable method of locking the wearing ring shall be used. Wearing rings shall be provided in pump casing and/or impeller as per manufacturer's standard practice.

#### **4.05.00 Shaft**

4.05.01 The critical speed shall be well away from the operating speed and in no case less than 130% of the rated speed.

4.05.02 The shaft shall be ground and polished to final dimensions and shall be adequately sized to withstand all stresses from rotor weight, hydraulic loads, vibration and torques coming in during operation.

#### **4.06.00 Shaft Sleeves**

4.06.01 Renewable type fine finished shaft sleeves shall be provided at the stuffing boxes/ mechanical seals. Length of the shaft sleeves must extend beyond the outer faces of gland packing of seal end plates so as to distinguish between the leakage between shaft and shaft sleeve and that past the seals/ gland.

4.06.02 Shaft sleeve shall be fastened to the shaft to prevent any leakage or loosening. Shaft and shaft sleeve assembly should ensure concentric rotation.

#### **4.07.00 Bearings**

4.07.01 Heavy duty bearings, adequately designed for the type of service specified in the enclosed pump data sheet and for long, trouble free operation shall be furnished

4.07.02 The bearings offered shall be capable of taking both the radial and axial thrust coming into play during operation. In case, sleeve bearings are offered additional thrust bearings shall be provided. Antifriction bearings of standard type, if provided, shall be selected for a minimum life 16,000 hrs. of continuous operation at maximum axial and radial loads and rated speed.

4.07.03 Proper lubricating arrangement for the bearings shall be provided. The design shall be such that the bearing lubricating element does not contaminate the liquid pumped. Where there is a possibility of liquid entering the bearings suitable arrangement in the form of deflectors or any other suitable arrangement must be provided ahead of bearings assembly.

4.07.04 Bearings shall be easily accessible without disturbing the pump assembly. A drain plug shall be provided at the bottom of each bearings housing.

#### **4.08.00 Stuffing Boxes**

	<b>TITLE:</b>	SPECIFICATION NO. PE-TS-445-155A-A001	
	<b>1 X 660 MW SAGARDIGHI TPS UNIT NO. 5 PHASE III</b>	SECTION : II	
	<b>TECHNICAL SPECIFICATION FOR CONDENSATE POLISHING UNIT</b>	<b>SUB-SECTION: IIA</b>	
		<b>REV. NO. 02</b>	<b>DATE : 18.04.2022</b>

4.08.01 Stuffing box design should permit replacement of packing without removing any part other than the gland.

4.08.02 Stuffing boxes of packed ring construction type shall be provided wherever specified. Packed ring stuffing boxes shall be properly lubricated and sealed as per service requirements and manufacturer's standards. If external gland sealing is required, it shall be done from the pump discharge. The Bidder shall provide the necessary piping valves, fittings etc. for the gland sealing connection.

#### **4.09.00 Mechanical Seals**

4.09.01 Wherever specified in pump data sheet, mechanical seals shall be provided. Unless otherwise recommended by the tenderer, mechanical seals shall be of single type with either sliding gasket or bellows between the axially moving face and shaft sleeves or any other suitable type. The sealing faces should be highly lapped surfaces of materials known for their low frictional coefficient and resistance to corrosion against the liquid being pumped.

4.09.02 The pump supplier shall coordinate with the seal maker in establishing the seal chamber of circulation rate for maintaining a stable film at the seal face. The seal piping system shall form an integral part of the pump assembly. For the seals under vacuum service, the seal design must ensure sealing against atmospheric pressure even when the pumps are not operating. Necessary provision for seal water supply along with complete piping fittings and valves as required shall form integral part of pump supply.

#### **4.10.00 Pump Shaft Motor Shaft Coupling**

4.10.01 The pump and motor shafts shall be connected with an adequately sized flexible coupling of proven design with a spacer to facilitate dismantling of the pump without disturbing the motor. Necessary coupling guards shall also be provided.

#### **4.11.00 Base Plate**

4.11.01 A common base plate mounting both for the pump and motor shall be provided. The base plate shall be fabricated steel and of rigid construction, suitably ribbed and reinforced. Base plate and pump supports shall be so constructed and the piping unit so mounted as to minimize misalignment caused by mechanical forces such as normal piping strain, internal differential thermal expansion and hydraulic piping thrust. Suitable drain troughs and drip lip shall be provided.

#### **4.12.00 Assembly and Dismantling**

4.12.01 Assembly and dismantling of each pump with drive motor shall be possible without disturbing the grouting base plate or alignment.

#### **4.13.00 Drive Motor (Prime Mover)**

4.13.01 The kW rating of the drive shall be based on continuously driving the connected equipment for the conditions specified. In case, where parallel operation of the pumps are specified, the actual motor rating is to be selected by the tenderer considering overloading of the pumps in the event of tripping of operating pumps.

#### **5.00.00 TESTING FOR HORIZONTAL CENTRIFUGAL PUMPS**

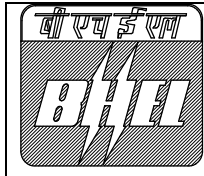

**TITLE:**  
**1 X 660 MW SAGARDIGHI TPS UNIT NO. 5**  
**PHASE III**

**TECHNICAL SPECIFICATION FOR**  
**CONDENSATE POLISHING UNIT**

SPECIFICATION NO. PE-TS-445-155A-A001

SECTION : II

**SUB-SECTION: IIA**

REV. NO. 02

DATE : 18.04.2022

The manufacturer shall conduct all tests required to ensure that the equipment furnished shall conform to the requirements of this specification and in compliance with the requirement of applicable Codes and Standards. The particulars of the proposed tests shall be submitted to the Owner for approval before conducting the tests.

#### **5.01.00 Hydrostatic Tests**

All pressure parts shall be hydraulically tested at 200% of pump rated head or at 150% shut off head whichever is higher. The test pressure shall be maintained for 1/2 hr. and no leakage shall be permitted. While arriving at the above pressure, the maximum suction head specified in Data Sheet shall be taken into account.

#### **5.02.00 Performance Tests**

5.02.01 All the pumps shall be tested in the Manufacture's Works at rated speed for capacity, efficiency and brake horse power. Pumps shall be given running test over the entire operating range covering from the shut off head to the maximum flow. The duration of test shall be minimum one (1) hour. A minimum of seven readings approximately equidistant shall be taken for plotting the curves with one point at design flow. Testing of pumps shall be in accordance with stipulations of Hydraulic Institute Standards or as applicable equivalent

5.02.02 The test shall be preferably conducted with the actual motor being furnished.

5.02.03 Only those pumps shall be subjected to strip down examination visually to check for mechanical damages after testing at shop in case abnormal noise level and excessive vibration is observed during the performance test. Otherwise strip down examination is limited to bearing inspection only.

5.02.04 The pump accessories e.g. the thrust bearing, couplings etc. shall be subjected to tests as per manufacturer's standards.

#### **5.03.00 Mechanical Balancing**

All rotating components of the pumps shall be statically balanced. In addition to static balancing, rotating components of the pumps shall be balanced dynamically at or near the operating speed. Tenderer shall furnish acceptance norm for this test.

#### **5.04.00 Visual Inspection**

Pumps shall be offered for visual inspection by the bidder before shipment. The components of the pumps shall not be painted before inspection.

#### **5.05.00 NPSH Test**

NPSH test shall be conducted with water as medium if required. NPSH shall not be mandatory in case type test certificates are furnished for the similar rating of pumps.

#### **5.06.00 Noise and Vibration Measurement**

Noise and vibration shall be measured during the performance testing at shop as well as during the site test.

	<b>TITLE:</b>	SPECIFICATION NO. PE-TS-445-155A-A001		
	<b>1 X 660 MW SAGARDIGHI TPS UNIT NO. 5 PHASE III</b>		SECTION : II	
	<b>TECHNICAL SPECIFICATION FOR CONDENSATE POLISHING UNIT</b>		<b>SUB-SECTION: IIA</b>	
			<b>REV. NO. 02</b>	<b>DATE : 18.04.2022</b>

5.06.01 The noise level shall not exceed 85 dBA. Noise level measurement will be made as per applicable internationally acceptable standard. The measurement shall be carried out with calibrated integrating sound level meter meeting the requirement of IEC:651 or BS:5969 or IS:9779. Sound pressure level will be measured all round the pump and motor set at a distance of one meter from the nearest surface of the machine and at a height of 1.5 m from the floor level. A minimum of six (6) points should be covered for measurement. The measurement shall be done with a slow response on the A-weighted scale. The average of the A-Weighted sound pressure measurements expressed in decibels to a reference 0.0002 microbars shall not exceed the specified value.

The tests shall be carried out on the machine operating at rated speed and as near as possible to the rated power. Corrections for background noise and correction on account of test environment will be considered in line with applicable standard. For this purpose all the additional data required should necessarily be collected during the test.

5.06.2 Vibration check will also be done as per HIS. Vibration would be checked at thrust bearing locations on horizontal, radial and vertical direction. The acceptance limits would be as per HIS. The instrument used would be IRD 308 or equivalent with velocity pick-up. Vibration limits to be specified as per the speed of the pump.

#### **5.07.00 Material Test Certificate**

5.07.01 Material of the various pump components shall be tested in accordance with the relevant standards. Test certificates for these shall be furnished for the Owner's approval.

5.07.02 Where stage inspection is desired by BHEL/customer all material test certificates shall be correlated and verified with the actual material used for construction before starting fabrication by BHEL/customer's inspector who will stamp the material. In case mill test certificate for the material are not available, the supplier shall carry out physical and chemical tests at his own cost from a testing agency, approved by BHEL/Customer, as per the requirement of specified material standard. The sample for physical and chemical testing shall be drawn up in presence of BHEL/Customer's inspector who shall also witness the testing.

#### **5.08.00 Non Destructive Testing**

- (a) UT shall be carried out on shafts of diameter more than 50 mm.
- (b) DP tests shall be carried out on shaft and impeller.
- (c) No weld repair shall be allowed on cast iron.

#### **5.09.00 Field Testing**

5.09.01 After installation, the pumps offered shall be operated to prove satisfactory performance as individual equipment as well as a system run. If the performance at site is found not to the requirements then the equipment shall be rectified or replaced by the Vendor, at no extra cost to the Owner. The procedure of the above testing will be mutually agreed between the Owner and the contractor. Noise and vibration tests shall also be repeated at site.

5.09.02 Based on observation of the trial operation, if modifications and repairs are necessary, the same shall be carried out by the contractor to the full satisfaction of the engineer and then the performance and guarantee tests to be repeated at site as per relevant clauses of the specification.



**TITLE:**  
**1 X 660 MW SAGARDIGHI TPS UNIT NO. 5**  
**PHASE III**

---

**TECHNICAL SPECIFICATION FOR**  
**CONDENSATE POLISHING UNIT**

SPECIFICATION NO. PE-TS-445-155A-A001

---

SECTION : II

---

**SUB-SECTION: IIA**

---

REV. NO. 02	DATE : 18.04.2022
-------------	-------------------

**TECHNICAL SPECIFICATION FOR METERING PUMPS**

	<b>TITLE:</b> <b>1 X 660 MW SAGARDIGHI TPS UNIT NO. 5 PHASE III</b>	SPECIFICATION NO. PE-TS-445-155A-A001	
	<b>TECHNICAL SPECIFICATION FOR CONDENSATE POLISHING UNIT</b>	SECTION : II	
		<b>SUB-SECTION: IIA</b>	
		<b>REV. NO. 02</b>	<b>DATE : 18.04.2022</b>

### 1.00.0 GENERAL

1.01.01 Specification cover the design, material, construction features, manufacture, inspection, testing the performance at the vendor's/sub-vendor's works, delivery to site, erection, commissioning and testing of metering pumps.

### 2.00.0 GENERAL DESIGN FEATURES

2.00.01 Pumps shall be simplex positive displacement hydraulically operated diaphragm design, driven by squirrel cage induction motor through suitable speed reduction unit. Maximum pump stroke speed shall not exceed 100 per minute.

2.00.02 The stroke shall be continuously adjustable to give a capacity variation 0-100% range while the pump is running or stopped. Adjustment of capacity shall be done by manual control facility (micrometric adjusting type) to be provided locally for each of the pump.

2.00.03 The stroke shall be continuously adjustable to give a capacity variation 0-100% range while the pump is running or stopped. Adjustment of capacity shall be done by manual control facility (micrometric adjusting type) to be provided locally for each of the pump.

2.00.04 Capacity variation may be effected by changing eccentricity of the driving crank or by suitable hydraulic circuit. Pump accuracy shall be industry standard  $\pm 1\%$  of capacity setting.

2.00.05 Pumps shall be provided with an integral relief valve, spring operated to release pressure when delivery line blockage occurs.

2.00.06 Crankcase shall be constructed of high quality cast iron, which will also house the gearbox and guides of cross head.

2.00.07 Guided, controlled travel, double-ball check valves or equivalent, shall be provided both on the suction and discharge side.

2.00.08 Material of construction of the various parts shall be as per the details furnished elsewhere in the specification. However all parts coming in contact with acid shall be of Haste alloy 'B' and for alkali it should be of SS-316 only.

2.00.09 Suitable gland seal shall be provided to prevent leakage.

2.00.10 Electric drive motor particulars should follow enclosed electrical chapters.

### 3.00.00 TESTING

#### 3.01.00 Testing and Inspection at Manufacturer's Works

3.01.01 The manufacturer shall conduct all tests required to ensure that the equipment furnished conforms to the requirements of this Specification and is in compliance with requirements of the applicable

	<b>TITLE:</b>	SPECIFICATION NO. PE-TS-445-155A-A001		
	<b>1 X 660 MW SAGARDIGHI TPS UNIT NO. 5 PHASE III</b>		SECTION : II	
	<b>TECHNICAL SPECIFICATION FOR CONDENSATE POLISHING UNIT</b>		<b>SUB-SECTION: IIA</b>	
			<b>REV. NO. 02</b>	<b>DATE : 18.04.2022</b>

codes. The particulars of the proposed tests and the procedures for the tests shall be submitted to Owner for approval before conducting the tests.

- 3.01.02 The Owner's representatives shall be given full access to all tests for which the Manufacturer shall inform the Owner allowing adequate time so that if the Owner so desires, his representatives can witness the test.
- 3.01.03 All materials and castings used for the equipment shall be of tested quality. The test certificates shall be made available to Owner.
- 3.01.04 The pump casing shall be hydraulically tested at 200% pump operating pressure or 150% of design pressure whichever is higher. The test pressure shall be maintained at least for ½ an hour.
- 3.01.05 The rotating parts of pump drive shall be subjected to static balancing.
- 3.01.06 All pumps shall be tested at the shop for capacity, volumetric accuracy, repetitive accuracy, power and volumetric efficiency. The tests are to be done according to the requirements of the "Hydraulic Institute" of U.S.A. and Indian Standards as applicable.
- 3.01.07 The pump accessories e.g. gear box, speed reduction unit etc. will be subjected to tests as per manufacturer's standards. The test results shall be furnished to the Owner.
- 3.01.08 The combined variation of the pump and motor should be restricted within limits specified by Hydraulic Institute Standard, USA when the pump operated singly or in parallel.
- 3.01.09 All pumps shall be subject to strip down examination visually to check for mechanical damages after performance testing at shop.
- 3.01.10 Diaphragm of the metering pump shall be type tested as per applicable code/standard.
- 3.01.11 Performance test shall be carried out for the setting of pressure relief valve.
- 3.01.12 Test reports and certificates of all the above-mentioned tests to ensure satisfactory operation of the system shall be submitted to the Owner for approval before dispatch.

### **3.02.00 Test at Site**

After erection at site pumps as detailed under different groups shall be operated to prove satisfactory performance as individual equipment as well as a system. If the performance at site is found to be not to the requirements, then the equipment shall be rectified or replaced by the Vendor at no extra cost to the BHEL/ Owner.



**TITLE:**  
**1 X 660 MW SAGARDIGHI TPS UNIT NO. 5**  
**PHASE III**  
**TECHNICAL SPECIFICATION FOR**  
**CONDENSATE POLISHING UNIT**

SPECIFICATION NO. PE-TS-445-155A-A001  
SECTION : II  
**SUB-SECTION: IIA**  
REV. NO. 02      DATE : 18.04.2022

**TECHNICAL SPECIFICATION FOR PRESSURE & STORAGE VESSEL**

	<b>TITLE:</b> <b>1 X 660 MW SAGARDIGHI TPS UNIT NO. 5</b> <b>PHASE III</b>	SPECIFICATION NO. PE-TS-445-155A-A001	
		SECTION : II	
	<b>TECHNICAL SPECIFICATION FOR</b> <b>CONDENSATE POLISHING UNIT</b>	<b>SUB-SECTION: IIA</b>	
		<b>REV. NO. 02</b>	<b>DATE : 18.04.2022</b>

## 1.00.00 GENERAL

The following principal pressure and atmospheric vessels for the system has been covered in this part of specification.

1. Condensate Polisher Service vessels.
2. Condensate Polisher Resin Separation and Cation Regeneration vessel.
3. Condensate Polisher anion regeneration vessel.
4. Condensate Polisher mixed resin storage Vessel.
5. Alkali diluent Heating cum Storage Vessel.( hot water tank)
6. Activated carbon filter
7. Alkali Preparation Tank
8. Alkali Day Tank
9. Resin Injection Hopper
10. Acid Measuring Tank.
11. Acid Storage Tank
12. DM storage tank.
13. Alkali storage tank

1.01.00 Of these, the items specified from Sr. no. 1 to 6 shall be designed as pressure vessels and the rest shall be atmospheric vessels.

1.01.01 All other vessels, not specifically listed here, but required for the Bidder's system shall also meet the general requirements of this specification.

1.01.02 Process requirements of these vessels shall be governed by the requirements of the Condensate Polishing System, which will determine their design conditions. Following sections only indicate some of the minimum requirements which must be met, and the actual design of these vessels shall be better than these, if that is required from process considerations.

## 2.00.00 GENERAL DESIGN FEATURES

### 2.01.00 Design

2.01.01 Design of all pressure vessels shall conform to ASME Section VIII or acceptable equivalent international standard. Design pressure shall be the maximum expected pressure to which the vessels may be subjected to plus 10% additional margin. Maximum expected pressure for vessels placed in the discharge line of pumps shall be based on the shut-off head of the pumps plus static head at pumps suction if any. Design pressure of condensate service vessels is indicated elsewhere in this specification. For all other pressure vessels, design pressure shall be at least 10 Kg/cm<sup>2</sup> (g) minimum or as per system design whichever is higher.

	<b>TITLE:</b>	SPECIFICATION NO. PE-TS-445-155A-A001		
	<b>1 X 660 MW SAGARDIGHI TPS UNIT NO. 5 PHASE III</b>		SECTION : II	
	<b>TECHNICAL SPECIFICATION FOR CONDENSATE POLISHING UNIT</b>		<b>SUB-SECTION: IIA</b>	
			<b>REV. NO. 02</b>	<b>DATE : 18.04.2022</b>

- 2.01.02 Design of all vertical cylindrical atmospheric storage tanks containing water, acid, alkali and other chemicals shall conform to IS: 803.
- 2.01.03 Design of all horizontal cylindrical atmospheric storage tank containing water, acid, alkali and other chemicals shall conform to BS EN12285-2:2005.
- 2.01.04 Design temperature of all pressure vessels and storage tanks shall be 10 deg. C higher than the maximum temperature that any part of the vessel/tank is likely to attain during operation.
- 2.01.05 In case, tank is subjected to vacuum; the same shall be taken care in designing the tank.
- 2.01.06 The design of Demineralised water storage tanks (Vertical type) shall conform to IS: 803. Supporting frame where required shall be in accordance with IS: 800. The tank shall be "Non-pressure" fixed roof type with atmospheric vents.
- 2.02.00 All vessels / tanks without inside rubber lining shall have a corrosion allowance of minimum 2 mm and mill allowance (minimum 0.3 mm) for shell and dished ends. Thinning allowance of 2 mm (minimum) shall be considered for dished end. Vessel / tanks ends shall be of dished design and constructed by forging, pressing or spinning process. Conical or flat ends shall not be accepted. All dished ends shall be stress relieved.
- 2.03.00 All the atmospheric tanks shall have sufficient free board above the "Level High"/"Normal Level" as the case may be. The overflow level shall be kept at least 30 cm or 10% of vessel height above the "Level High"/"Normal Level" for all the tanks except for the DM tanks for which a minimum height of 300 mm shall be provided over the "High Level". Further, a minimum 300 mm free board shall be provided above the top of overflow level to the top of the tank. Wall thickness of atmospheric tanks shall not be less than 6 mm.
- 2.04.00 Vessels coming under preview of IBR shall be designed accordingly.
- 2.05.00 Interior surfaces of all tanks shall be clear of stiffeners and other structural supports. Tanks shall be reinforced and stiffened externally as required.
- 2.06.00 All welds on inner tank surface shall be free of voids, gaps craters, pits, high spots, sharp edges, abrupt ridges and valleys or undercut edges. High spots, irregularities and sharp edges shall be removed by grinding. Inside weld seams shall be ground flush and smooth applicable for corrosion resistant coating or lining.
- 2.07.00 All internal baffles, wear plates, pipes etc. shall be continuously welded on both sides at all contact points with full fillet welds which shall be free of voids, gaps, craters, high spots, sharp edges, and undercutting. Sharp edges shall be ground to a 3 mm minimum radius.
- 2.08.00 Weld splatter shall be removed.
- 2.09.00 All welding shall be performed by ASME qualified welders under Section-IX of ASME Boiler and Pressure Vessel code and welding electrodes shall be as per relevant Codes/Standards viz. AISC Section 1.17 etc.
- 2.10.00 The plates for cylindrical tanks shall be accurately formed in bending rolls to the diameters called for, and the completed shells be concentric and plump. Plates shall be cold-rolled by plate bending machine in a number of passes to true curvature and joined by welding.
- 2.11.00 Vessels seam shall be so positioned that they do not pass through vessel connections.
- 3.00.00 MATERIAL OF CONSTRUCTION**

	<b>TITLE:</b>	SPECIFICATION NO. PE-TS-445-155A-A001		
	<b>1 X 660 MW SAGARDIGHI TPS UNIT NO. 5 PHASE III</b>		SECTION : II	
	<b>TECHNICAL SPECIFICATION FOR CONDENSATE POLISHING UNIT</b>		<b>SUB-SECTION: IIA</b>	
			<b>REV. NO. 02</b>	<b>DATE : 18.04.2022</b>

3.01.00 All pressure vessels shall be fabricated from carbon steel plates as specified in datasheet A of this specification and lined internally. All atmospheric tanks shall be fabricated of material as specified in datasheet A and lined internally.

#### 4.00.00 APPURTENANCES

##### 4.01.00 Manholes

4.01.01 All the pressure vessels and horizontal type storage tanks shall be provided with manhole of 500 mm diameter minimum size, preferably at the top head, complete with cover plate, lifting handle, davit cap, nuts, bolts, gaskets etc. to ensure leak tightness at the test pressure.

4.01.02 The vertical type storage tanks shall be provided with a manhole of 500 mm dia on the top cover, if the diameter of the tank is 1200 mm or more. For the DM water storage tanks, manholes shall be provided as per IS:803.

4.01.03 All the vessels and tanks shall be normally provided with a six inch gasketed handhole located near the bottom of the straight side.

4.01.04 The required lining/coating for the inside surface of the manhole/handhole, nozzle and cover plate of the manhole/handhole shall be same as that of the respective vessel/tank.

##### 4.01.05 Sight Glasses

All the vessels mentioned shall be provided with pad type sight glasses on their vertical sides. Locations of these sight glasses shall be as follows:

4.01.06 One with the centre line at the normal level of the bed top, and one near the bottom of the straight side, for each of these vessels.

4.01.07 In addition, item no. 1.00.00 shall be provided with sight glasses, with their center lines at each of the normal separated resin interfaces.

##### 4.02.00 Lifting Lugs

All vessels of diameter 1200mm or greater shall be provided with a minimum of 4 lifting lugs. Smaller vessels shall be provided with at least 2 lifting lugs.

##### 4.03.00 Vessels Supports

Adequate supporting arrangements like straps, saddles, skirt rings, or legs of steel shall be provided to transfer all loads to the respective skid structures.

##### 4.04.00 Vessel Internals

The internals for pressure Vessels shall be designed for a low pressure drop to promote uniform distribution and flow through the vessels and to withstand the full design pressure of the vessel in both directions.

Specification requirements for vessel internals are as follows:

##### 4.05.00 Inlet water and Regenerant Distributors

Hub and laterals with diffuser splash plates or header and perforated laterals. Material of

	<b>TITLE:</b>	SPECIFICATION NO. PE-TS-445-155A-A001		
	<b>1 X 660 MW SAGARDIGHI TPS UNIT NO. 5 PHASE III</b>		SECTION : II	
	<b>TECHNICAL SPECIFICATION FOR CONDENSATE POLISHING UNIT</b>		<b>SUB-SECTION: IIA</b>	
			<b>REV. NO. 02</b>	<b>DATE : 18.04.2022</b>

construction shall be type 316 stainless steel, except for acid service which shall be of Hastelloy B.

**4.06.00 Underdrains**

Same as above with screened laterals with internal perforated pipes, and rubber-lined false bottom. For resin separation/regeneration/mixed resin vessels, it may have fully screened bottom (NEVA – clog type with para Septanurse screen, fully supported by subway grid, or equal).

4.07.00 For lined vessels, they shall also be lined in the same manner as the internal surfaces of these vessels. For the caustic diluent heating/storage tank, they shall be of type 304 stainless steel construction.

**4.08.00 Internal Fasteners**

All internal fasteners shall be of type 316 stainless steel and heavy duty locknuts shall be used throughout.

**4.09.00 Piping Connections**

All lined vessel connections and connections in unlined vessels 25 NB and larger shall be to ANSI 300 lb class. Flat face flanges shall be used throughout. Nozzle material shall be ASTM-A-106. Grade B. schedule 80 pipe. All flanged connections shall be supplied complete with matching counter flanges, nuts, bolts and full-face gaskets.

4.10.00 All vessel connections in unlined tanks smaller than 25 NB shall be screwed to ANSI 2.1 for schedule 80 pipe.

**4.11.00 Resin Traps**

Outlets of each of the condensate polisher service vessel and the waste effluent header of the common external regeneration facility, shall be provided with a resin trap. These resin traps shall be a minimum, conform to the following:

4.11.01 The resin trap shells shall be of steel construction and lined internally with saran or Polypropylene. The internals for all traps shall be johnson well screen type, of 316 stainless steel in both directions, resin traps located in processes effluent lines shall have a screen opening that does not exceed 120 percent of the associated process vessel under drain screen opening. Resin traps located in waste effluent headers shall have a screen opening of approximately 60 mesh.

4.11.02 Each resin trap shall be fully piped and valved for inplace manual back flushing.

**5.00.00 SPECIFIC DETAILS**

**5.01.00 Alkali Diluent Heating – Storage Tank (Hot water tank)**

Hot water tank for heating of alkali diluent water with (2X60%) electric heating coil, of MOC as specified in sub section –IA of this specification shall be provided by bidder. The capacity of tank shall be minimum 20% higher than the maximum water demand. This tank shall be provided with burn out protection, pressure relief valve, level switches, temperature indicator etc. The heaters shall be sized for heating the water from a temperature of 15 to 50 deg. C in 5 hours at the outlet of ejector.

All tank internals, including the inlet water tail pipe, shall be fabricated of type 304 stainless

	<b>TITLE:</b> <b>1 X 660 MW SAGARDIGHI TPS UNIT NO. 5</b> <b>PHASE III</b>	SPECIFICATION NO. PE-TS-445-155A-A001	
		SECTION : II	
	<b>TECHNICAL SPECIFICATION FOR</b> <b>CONDENSATE POLISHING UNIT</b>	<b>SUB-SECTION: IIA</b>	
		<b>REV. NO. 02</b>	<b>DATE : 18.04.2022</b>

steel.

5.02.00 **Atmospheric Tanks**

Wall thickness of these tanks shall not be less than 6mm.

5.03.00 **Resin Injection Hopper**

The supplier shall provide a hopper type tank for resin make-up, using water slurry, to the condensate polishing systems. This make-up system will constitute a portion of the condensate polishing external regeneration system. The resin hopper shall have a conical bottom and a flat top. The top shall have a piano type hinged port, having a lifting handle, of sufficient size for easy resin loading. The resin shall discharge through a bottom connection to a water ejector for transport. Water shall be added to the hopper to assist in the resin transfer. The ejector discharge shall be to the resin separation-cation regeneration vessel. Demineralized water shall be used throughout for the resin transfer. Piping of the resin make-up system shall be the responsibility of the Bidder as a part of the external resin regeneration system.

a) **Capacity**

The resin make-up hopper tank shall be sized to handle up to 150 liters of as received new resin per single injection.

b) **Material**

The resin make-up hopper tank shall be fabricated of mild carbon steel having a minimum thickness of 6mm and lined.

5.04.00 **Chemical preparation and day tanks**

These shall be vertical cylindrical tanks. They shall be of carbon steel fabrication, lined and provided with full height level gauges right up to the overflow levels.

The alkali preparation tank shall be provided with a dissolving basket of type 316 stainless steel constructions, and a motorized slow speed stirrer mounted eccentrically to the tank by a bracket fixed to the side wall. The stirrer shall have impellers of type 316 stainless steel.

The alkali day tank shall be provided with an airtight cover complete with a breather arrangement, to prevent absorption of carbon dioxide from the atmosphere by the alkali solution contained in it. The overflow connection shall also be provided with a suitable seal for this purpose.

The tanks for ammonia solution (if applicable) shall also be provided with similar arrangements to prevent escape of ammonia vapour to outside.

5.05.00 **LINING**

All internal lining of vessels provided under this specification shall be of natural rubber, meeting the following minimum requirements.

5.05.01 **Hardness**

Lining used may be soft rubber having a shore durometer reading or 65 on the A scale, or semi-hard rubber having a durometer reading of 65 on the A scale. Variations in hardness of the rubber lining between the different areas of a specific tank shall be within +/-5 durometer reading.

	<b>TITLE:</b> <b>1 X 660 MW SAGARDIGHI TPS UNIT NO. 5</b> <b>PHASE III</b>	SPECIFICATION NO. PE-TS-445-155A-A001	
		SECTION : II	
	<b>TECHNICAL SPECIFICATION FOR</b> <b>CONDENSATE POLISHING UNIT</b>	<b>SUB-SECTION: IIA</b>	
		<b>REV. NO. 02</b>	<b>DATE : 18.04.2022</b>

#### 5.05.02 **Chemical Resistance**

The lining material shall be suitable for prolonged service in the chemical environment described below:

- Hydrochloric acid, 2 to 8% concentration, at temperature from 10 deg C to 50 deg C.
- Sodium hydroxide, 1 to 4% concentration, at temperature from 30 deg C to 50 deg C.
- 100 to 500 mg /l of sulphuric and hydrochloric acid combined. Ratio of concentration of these two acid 1 : 5 to 5 : 1 and temperatures from 10 deg C to 40 deg C.
- 1 to 10mg/l of sodium hydroxide at temperature from 10 deg C to 40 deg C.

The linings will be subjected to the condition (a) or (b) for intermittent periods of approximately one hour out of eight hours, and to conditions (c) or (d) remainder of the time.

#### 5.05.03 **Thickness**

The lining shall be applied in three layers, resulting in a total thickness of not less than 4.5 mm anywhere on the internal surfaces of the vessels. The lining shall extend over the full face of all flanged connections and shall have a minimum thickness of 3 mm in all such external areas.

#### 5.05.04 **Surface Preparation**

Prior to rubber lining all surfaces must be prepared in the following manner.

- Degrease surface prior to blasting.
- The surface is to be blasted with steel grit or sharp silica sand to a white and bright metal surface.
- All traces of grit and dust should be removed with a vacuum cleaner or by brushing. Care must be taken to avoid contaminating the surface.
- Immediately after blasting and removal of grit, the first coat of primer or cement shall be applied and allowed to dry.

#### 5.05.05 **Protection**

After the lining is completed the vessels shall not be subjected to any prolonged exposure to direct sunlight in course of its transportation erection, etc. They shall not also be stored in direct sunlight. No further welding or burning shall be carried out on the vessel, after application of the lining.

All lining projecting outside of the vessel, shall be protected adequately from mechanical damages during shipment, handling, storage etc.

Suitable warning, indicating the special care that must be taken with respect to these lined vessels, shall be stenciled on their outside surfaces with the letter at least 12mm high.

Example:

	<b>TITLE:</b>	SPECIFICATION NO. PE-TS-445-155A-A001		
	<b>1 X 660 MW SAGARDIGHI TPS UNIT NO. 5 PHASE III</b>		SECTION : II	
	<b>TECHNICAL SPECIFICATION FOR CONDENSATE POLISHING UNIT</b>		<b>SUB-SECTION: IIA</b>	
			<b>REV. NO. 02</b>	<b>DATE : 18.04.2022</b>

“Warning – Tank is lined”

“Do not weld or Burn”

“Do not Store in Direct Sunlight” etc.

#### 6.00.00

#### CODES AND STANDARDS

The design, manufacture, shop testing, site fabrication and erection, testing and commissioning of the pressure and storage vessels shall conform to the latest revisions of the following standards, in addition to other standards mentioned elsewhere in the tender document subject to any modification and requirement, as specified here in after.

- |    |         |   |  |
|----|---------|---|--|
| a) | IS: 803 | - | Code of practice for design, fabrication and erection of Vertical Mild Steel cylindrical welded oil storage tanks. |
| b) | IS: 816 | - | Code of practice for use of metal arc welding for general construction in mild steel.                              |
| c) | IS: 817 | - | Code of practice for training and testing of metal arc welders.  |
| d) | IS: 822 | - | Code of procedure for inspection of welds.   |
| e) | IS:1363 | - | Black hexagonal bolts, nuts and locknuts (dia 6 to 39 mm) and black hexagon screws (dia to 24 mm).                 |
| f) | IS:1367 | - | Technical supply conditions for threaded fasteners.  |
| g) | IS:2062 | - | Specification for weld able structural steel.  |
| h) | IS:2002 | - | Steel plates for pressure vessels for intermediate and High temperature service including boilers.                 |
| i) | IS:2825 | - | Code of unfired pressure vessels.  |
| j) | IS:3133 | - | Manhole and inspection opening for chemical equipment.   |
| k) | IS:4049 | - | Specification for formed ends for tanks and pressure vessels.  |
| l) | IS:4682 | - | Code of practice for lining of vessels and equipment for chemical processes Rubber Lining.                         |
| m) | BS:2594 | - | Specification for carbon steel welded horizontal cylindrical storage tanks.  |
| n) | ASME    | - | Boiler and pressure vessel Section VIII code.  |
| o) | ASTM    | - | American Society for Testing and Materials.  |

#### 7.00.00

#### FABRICATION

##### 7.01.00

The vessel ends for storage tanks of vertical type shall have flat bottom. However, the ends of horizontal storage tanks, and all the pressure vessels shall be dished design of Tori-spherical type designed.

	<b>TITLE:</b>	SPECIFICATION NO. PE-TS-445-155A-A001		
	<b>1 X 660 MW SAGARDIGHI TPS UNIT NO. 5 PHASE III</b>		SECTION : II	
	<b>TECHNICAL SPECIFICATION FOR CONDENSATE POLISHING UNIT</b>		<b>SUB-SECTION: IIA</b>	
			<b>REV. NO. 02</b>	<b>DATE : 18.04.2022</b>

- 7.02.00 The plates to be used for fabrication shall preferably have a minimum width of 1500 mm.
- 7.03.00 All the joints (circumferential / longitudinal) shall be continuous butt welded, inside and outside. Connection shall be flush with inner surface of tanks and welded continuously on both sides of shell. Sharp inside edges shall be rounded to a minimum 3 mm radius.
- 7.04.00 Welding sequence shall be adopted in such a way so as to minimize the distortion due to welding shrinkage. Contractor shall indicate in his drawing the sequence of welding proposed by him which should meet prior approval of the engineers. Welding shall not be carried out when the surface of the parts to be welded are wet from any cause and during periods of rain and high winds unless the welder and work are properly shielded.
- 7.05.00 All pressure vessels and storage tanks except Demineralised (DM) water shall be fabricated complete and tested at manufacturer's works to ensure better workmanship.
- 7.06.00 **Tank Connections**
- 7.06.01 Bidder shall furnish all pipe material required for tank connection for the process requirement. In addition to these, additional connections, if required by the Owner for the inter-connection of their piping, instrumentation etc. shall also be provided. Such additional requirement will be intimated to the successful Bidder later and Contractor shall provide these fittings to match with the Owner's items. Adequate pipe support attachments in the external surface of the tank/vessel shall be provided for Owners pipes for all the vessels/tanks. All lined vessels connections shall be conforms to ANSI 300 lb class. Nozzle material shall be ASTM-106 Grade B, Schedule 80.
- 7.06.02 All flanged connections should be supplied complete with matching counter flanges, nuts bolts and gasket materials. The flange design, (thickness and drilling etc.) shall match with the interconnected piping flanges.
- 7.06.03 Bolts and nuts to be used externally to the vessels shall be of hexagonal head conforming to IS:1367. However, internal fasteners if any, shall be of IS:316 /SS-304 or Hastalloy-B as per the duty conditions.
- 7.06.04 Gaskets shall be of full face type.
- 7.06.05 Sight glasses shall be provided for the tanks/vessels as specified in the standard specification. The material for sight glass shall be high quality transparent PLEXIGLASS of sufficient thickness to withstand the test pressure. The sight glass shall be provided with suitable gaskets and bolts to ensure leak tightness at the test pressure.
- 7.07.00 **Vessels Supporting Lifting Lugs**
- 7.07.01 Adequate supporting arrangements like straps, saddles, skirt boards, pillars etc. shall be provided to transfer all loads to civil foundation. All foundation bolts, inserts etc. shall also be provided.
- 7.07.02 All vessels of internal, diameter of 1200 mm or greater shall be provided with minimum four (4) lifting lugs for safe and effective handling during erection. Smaller vessels shall be provided with at least two (2) lifting lugs.
- 7.07.03 Material of construction for these vessel supports, saddles, lugs shall conform to IS:2062 of tested quality.
- 7.08.00 **Special Accessories Storage Tanks**

	<b>TITLE:</b> <b>1 X 660 MW SAGARDIGHI TPS UNIT NO. 5</b> <b>PHASE III</b>	SPECIFICATION NO. PE-TS-445-155A-A001	
		SECTION : II	
	<b>TECHNICAL SPECIFICATION FOR</b> <b>CONDENSATE POLISHING UNIT</b>	<b>SUB-SECTION: IIA</b>	
		<b>REV. NO. 02</b>	<b>DATE : 18.04.2022</b>

- 7.08.01 Vessel internals wherever required shall be provided as detailed out elsewhere in the specification.
- 7.08.02 All the pressure vessels and tanks shall be provided with drain connections along with drain valves of suitable size. Further all the atmospheric storage tanks shall be provided with over flow connection designed for the filling rate of the respective tank.
- 7.08.03 All the pressure and tanks shall be provided with the vent connections. The design shall be as to offer adequate area for venting. Venting area shall be such that over pressure/vacuum is not created in the tank during maximum filling/drain-off rate. The maximum draw off rate for the DM storage tanks shall be intimated later to the successful bidder.
- 7.08.04 Various instrumentation and the fittings required for the same shall be supplied as elaborated in data sheets.
- 7.08.05 Water seal shall be provided for the overflow line of DM and degassed water storage tanks. The vent and overflow lines of alkali preparation /measuring / day tanks and vent line of DM storage tanks shall be provided with Carbon dioxide absorber of proven design to prevent contamination from atmospheric air. Carbon dioxide absorber shall preferably be located at ground level. The vent and overflow lines of Acid measuring tanks shall be provided with fume absorber using suitable packing material, such as pall rings/raschig rings.
- 7.08.06 Conservation vent valves shall be provided in the vent line of DM storage tanks so that, at a vacuum to the extent of 65 mm water column, the valve shall open to relieve the vacuum. Body and trim of the valve shall be Die Cast Aluminum.



**TITLE:**  
**1 X 660 MW SAGARDIGHI TPS UNIT NO. 5**  
**PHASE III**  
**TECHNICAL SPECIFICATION FOR**  
**CONDENSATE POLISHING UNIT**

SPECIFICATION NO. PE-TS-445-155A-A001  
SECTION : II  
**SUB-SECTION: IIA**  
REV. NO. 02      DATE : 18.04.2022

**TECHNICAL SPECIFICATION FOR VERTICAL CENTRIFUGAL PUMPS**

	<b>TITLE:</b>	SPECIFICATION NO. PE-TS-445-155A-A001		
	<b>1 X 660 MW SAGARDIGHI TPS UNIT NO. 5 PHASE III</b>		SECTION : II	
	<b>TECHNICAL SPECIFICATION FOR CONDENSATE POLISHING UNIT</b>		<b>SUB-SECTION: IIA</b>	
			<b>REV. NO. 02</b>	<b>DATE : 18.04.2022</b>

### 1.00.00 GENERAL INFORMATION

1.01.00 The general guidelines as illustrated in the subsequent clauses of this section shall be applicable for vertical pumps to be procured under the scope of this package.

### 2.00.00 CODES AND STANDARDS

2.01.00 In addition to the requirements spelt out elsewhere in the specification, the equipment to be provided under this section shall specifically conform to the following codes, standards, specifications and regulations, as applicable, including all the latest amendments subsequent to the year of publication as mentioned below.

2.01.01 IS 1710/1989: Vertical Turbine Pumps for Clear, Cold and Fresh Water.

2.01.02 IS 5120/1977: Technical requirements - Rotodynamic special purpose pumps.

2.01.03 IS 5639/1970: Pumps for handling chemical and corrosive liquids.

2.01.04 IS 5659/1970: Pumps for process water.

2.01.05 IS 6536/1972: Pumps handling volatile liquids.

2.01.06 IS 9137/1978: Code for acceptance for centrifugal, mixed flow and axial  
Flow pumps - Class 'C'

2.01.07 BS 5316: Acceptance tests for Centrifugal, mixed flow Part-I/1976 And axial flow pumps -  
Class 'C' Tests (ISO 2548/1973)

2.01.08 BS 5316: Acceptance tests for Centrifugal, mixed flow Part- II/1977 And axial flow pumps  
- Class 'B' Tests (ISO 3555/1977)

2.01.09 ANSI B 73.2M : Vertical inline centrifugal pumps for chemical process 1984

2.01.10 API 610/1989: Centrifugal pumps general refinery services.

2.01.11 Hydraulic Institute Standards of USA (1983).

2.01.12 PTC 8.2/1965: Power Test Codes - Centrifugal pumps.

### 3.00.00 Accessories:

All the pumps under this specification shall be complete with following standard/special accessories.

#### 3.01.00 Standard accessories:

- a) Pump motor coupling along with coupling guard
- b) Common base plates for pump and motor.
- c) Lubrication system along with all internal piping, valves, fittings, specialties etc. as required.
- d) Counter flanges for suction/ discharge nozzles along with fixing nuts, bolts and gaskets.
- e) Anchor bolts, nuts, seating steel works, etc. as necessary for mounting the pump-motor unit on Civil foundations.
- f) Suitable vent (with valves)/ lifting/ handling attachments for the pump/ motor/ Accessories.
- g) Suitable drain connections with isolating valves as applicable.
- h) Set of "Special" Tools & Tackles for Pumps and motors, if any.

	<b>TITLE:</b> <b>1 X 660 MW SAGARDIGHI TPS UNIT NO. 5 PHASE III</b>	SPECIFICATION NO. PE-TS-445-155A-A001	
	<b>TECHNICAL SPECIFICATION FOR CONDENSATE POLISHING UNIT</b>	SECTION : II	
		<b>SUB-SECTION: IIA</b>	
		<b>REV. NO. 02</b>	<b>DATE : 18.04.2022</b>

- i) Erection and commissioning spares, "on as required" basis.  
j) Bidder shall provide various drawings, data, calculations, test reports/ certificates, Operation and maintenance manuals, As-built drawings, etc. as specified and as necessary.

**3.02.00 Services included in Bidder's Scope:**

3.02.01 The pumps shall be guaranteed to meet the performance requirements as specified vide datasheet – A and also for trouble free operation after commissioning.

**4.00.00 TECHNICAL REQUIREMENTS:**

4.01.00 The pumps shall be Electric motor driven.

4.02.00 The Pumps shall conform to HIS

4.03.00 Vertical type pumps with 1500rpm.

4.04.00 Minimum efficiency of vertical pump will be 40%.

**4.05.00** No negative tolerance shall be permitted in rated capacity & TDH.

**4.06.00** No negative tolerance shall be permitted in efficiency at rated capacity.

**4.07.00** The shut off head of pumps shall be at least 115% of pump rated TDH.

**4.08.00** The pumps shall be capable of developing the required total head at rated capacity for Continuous operation. The pumps shall operate satisfactorily at any point on the Q-H Characteristic curve over a range of 0% to 130% capacity and shall be suitable for Continuous operation between 30% to 130% capacity.

**4.09.00** Selection of the pumps shall be such that the design point shall be met even with negative manufacturing tolerance.

**4.10.00** The total head capacity curve shall be continuously rising towards the shut off, the pumps shall preferably be non-overloading type and stable.

**4.11.00** The pumps shall be capable of running over the entire range of NPSH conditions required without any noise, vibration or cavitation.

**4.12.00** The pumps shall be of stiff shaft design. The minimum internal clearances should be sufficiently more than the max. Static deflection of the shaft. Shaft size selected must take into consideration the critical speed as specified in API-610.

**4.13.00** Pumps and motors shall run smooth without undue noise and vibration. The vibration shall be within 75 microns for pump - motor set. The noise level shall be limited to 85 dB at distance of 1.0M.

**4.14.00** High reliability of the pumps is an essential requirement and therefore it gets weight age over its efficiency. It is therefore essential that the bidder choose a standard proven model from the range of pumps manufactured.

**4.15.00** If water handled by pump is dirty/ not suitable for lubrication/ cooling, the bidder shall provide requisite strainer/ filters, tanks, motorized valves, etc. after the tap off for the required service, the arrangement provided shall be subject to Purchaser's approval.

**5.00.00 OTHER REQUIREMENTS:**

	<b>TITLE:</b>	SPECIFICATION NO. PE-TS-445-155A-A001		
	<b>1 X 660 MW SAGARDIGHI TPS UNIT NO. 5 PHASE III</b>		SECTION : II	
	<b>TECHNICAL SPECIFICATION FOR CONDENSATE POLISHING UNIT</b>		<b>SUB-SECTION: IIA</b>	
			<b>REV. NO. 02</b>	<b>DATE : 18.04.2022</b>

5.01.00 The materials of construction for various components specified are the minimum Requirements indicated in datasheet – A section C and materials of construction for other components not specified shall be similarly selected by the bidder for the intended duty.

**6.00.00 PAINTING FOR PUMPS:**

- a) The surface of SS, Gun metal, brass, bronze and non-metallic component shall not be applied with any painting.
- b) The Steel surface to be applied with painting shall be thoroughly cleaned before applying painting by brushing, shop blasting etc. as per the agreed procedure.

For all the steel surfaces inside the (indoor installation) building, a coat of red oxide primes of min. thickness of 50 microns followed up with under coat of Synthetic Enamel paint of min. thickness of 50 microns shall be applied. the top coat shall consist of two coats each of min. thickness of 50 microns of synthetic enamel paint and thus total thickness shall be min. 200 microns.

**7.00.00 PERFORMANCE REQUIREMENTS**

7.01.00 Pump (s) shall preferably be designed to have the best efficiency at the specified duty point. Further, the pumps (s) shall be suitable for continuous operation at any point within its 'range of operation'.

7.02.00 Under all circumstances, the 'range of operation' of the pump (s) shall exclude any Unstable operating zone of the head-capacity curve.

**8.00.00 DESIGN AND CONSTRUCTION**

Pumps shall be of vertical shaft, complete with bowl, column pipe, discharge head and base plate with all accessories. General design and constructional features of the pumps shall be as follows:

**8.01.00 BOWL ASSEMBLY**

8.01.01 This will be either a single, mixed flow or axial flow type with discharge co-axial with shaft. Type of impeller shall be chosen on the basis of the pump specific speed and the characteristics of handling fluid.

**8.02.00 IMPELLER SHAFT, LINE SHAFT AND HEAD SHAFT**

8.02.01 Shaft size shall be selected on the basis of maximum torque to be applied on the pump shaft. Critical speed of the shaft shall be sufficiently away from the pump operating speed and in no case shall lie between 90% and 110% of the rated speed.

8.02.02 Impeller shaft shall be guided by bearings provided in each bowl or above and below the impeller shaft assembly. The butting faces of the shaft shall be machined square to the assembly and the shaft shall chamfer at the edges.

8.02.03 Line shaft may be single or multiple pieces as required. In case of multiple pieces, line shaft shall be coupled as per the standard practice of the manufacture. For screwed coupling, directions shall permit tightening of the joint during pump operation.

8.02.04 Replaceable shaft sleeves shall be furnished at applicable location, particularly under stuffing box and at other locations, as considered necessary.

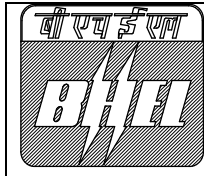

**TITLE:**  
**1 X 660 MW SAGARDIGHI TPS UNIT NO. 5**  
**PHASE III**

SPECIFICATION NO. PE-TS-445-155A-A001

SECTION : II

**TECHNICAL SPECIFICATION FOR**  
**CONDENSATE POLISHING UNIT**

**SUB-SECTION: IIA**

REV. NO. 02

DATE : 18.04.2022

**8.03.00 BEARINGS**

**8.03.01 SHAFT BEARINGS**

Adequate number of properly designed bearings shall be provided for smooth and trouble free operation of the pump. Number of bearings shall consider the number of shaft pieces used and the critical speed of the shaft. Bearings shall be either lubricated by external clear water/oil/grease or self-lubricated. In case of external water/oil lubrication, complete lubrication arrangement shall be furnished with the pump.

**8.03.02 THRUST BEARING**

Thrust bearing of adequate size and capacity shall be provided to take the vertical thrust of the impeller arising out of the pump operation and dead weight of the rotating Components. Life of the thrust bearing shall be guided by the design standard of the pump. Thrust bearing shall be capable of running continuously at maximum load. Thrust bearing shall be either grease or oil lubricated. Lubrication arrangement shall be such that the lubricant does not contaminate the handling fluid. The arrangement shall also be adequate to protect the bearing, while the pump coast down to stop in case of power failure of the station. Pre-lubrication of the thrust bearing, if recommended by the pump manufacturer, shall be taken care of in designing the lubrication system. Cooling of the thrust bearing, if necessary, shall be done by the handling fluid/external Water, depending on the fluid handled. Location of the thrust bearing may be at the pump body or at the driver, or at both depending on the requirement.

**WBPDC**

**EPC Bid Document**  
**Sagardighi Thermal Power Project**  
**1x660 MW Unit No. 5, Phase - III**

## SECTION-III

### MISCELLANEOUS HOISTS

#### **1.00.00 GENERAL INFORMATION**

- 1.01.00 The hoists will be used for erection and maintenance of various equipment in different buildings under the scope of Entire Package, except FGD and Coal Handling Plant, of 1 x 660 MW Sagardighi Thermal Power Project Unit 5, Phase-III. Hoists for FGD and CHP area are mentioned in Section-V of Volume-IIB and Volume II H1 respectively.
- 1.02.00 Hoists are divided into two separate groups - (a) Hand operated and (b) Electric operated.

#### **2.00.00 CODES AND STANDARDS**

The design, manufacture and testing of the equipment covered under this specification shall conform to the latest editions of the following Indian Standards:

- |         |                     |   |   |
|---------|---------------------|---|---|
| 2.01.00 | IS : 3832           | : | Specification for Hand Operated Chain Pulley-blocks.  |
| 2.02.00 | IS : 807            | : | Code of Practice for Design, Manufacture, Erection and Testing (Structural Portion) of Cranes and Hoists. |
| 2.03.00 | IS : 6216           | : | Short link Chain, Grade T(8) for Pulley-blocks & other Lifting Appliances.                                |
| 2.04.00 | IS : 2429 (part -I) | : | Non-calibrated Load Chain for Lifting Purposes.   |
| 2.05.00 | IS : 15560          | : | Point Hook with Shank up to 160 tones - Specification   |
| 2.06.00 | IS : 3938           | : | Specification for Electric Wire Rope Hoists.  |

and other Indian Standards referred to in the above standards.

#### **3.00.00 SCOPE OF WORK**

- 3.01.00 Hoists shall be provided in all areas under the scope of this specification (except the areas covered by E.O.T. cranes) where any equipment/component weighing above 100 kg is installed and needs to be handled for maintenance purposes. Number of monorail beams shall be such that the centre line of the hoist and the centre line of equipment to be handled shall be not more than 500 mm.



**WBPDC**

**EPC Bid Document**  
**Sagardighi Thermal Power Project**  
**1x660 MW Unit No. 5, Phase - III**

- 3.01.01 The location and no. of hoists is to be finalised during detailed engineering. Final arrangement is subject to approval of Owner/Consultant.
- 3.01.02 Monorail hoists shall at least be provided in the areas mentioned in Annexure-I. The list is indicative only and not an exhaustive one.
- 3.01.03 Besides monorail hoists, fixed Chain Pulley blocks of following capacities shall be provided:

Capacity (T)	Nos.
1	10
3	10
5	8
10	3

- 3.02.00 All drive motors and driving gears as necessary.
- 3.03.00 Limit switches for electrical hoist as necessary.
- 3.04.00 Trailing cable with all supporting fixtures as necessary for electric hoists.
- 3.05.00 Pendant control station with all accessories for electric hoists.
- 3.06.00 Lifting lug, eye bolts etc., for handling hoist parts.
- 3.07.00 Protection guard as specified.
- 3.08.00 Lifting hook block assembly for hoists.

#### **4.00.00 SPECIFIC DESIGN REQUIREMENTS**

- 4.01.00 Lifting capacity
- 4.01.01 Capacity of each hoist shall be 1.2 times the maximum working load.
- 4.01.02 Hoists of capacity below 3 tones shall be manual hoists.
- 4.01.03 Hoists of capacity equal and above 3 tones shall be electric hoists.
- 4.02.00 Effort for Mechanical Hoists
- 4.02.01 Hoisting
- Hoisting effort for hoists up to 3 tones capacity shall not be more than 20 kg.





**WBPDCL**

**EPC Bid Document  
Sagardighi Thermal Power Project  
1x660 MW Unit No. 5, Phase - III**

**4.02.02 Trolley Motion**

Effort for trolley motion for hoists upto 3 tones capacity shall not be more than 43 Kg.

**4.02.03 For Electric operated hoist both hoisting and trolley motion shall be motor operated.**

**4.03.00 Lift**

**4.03.01 Lift above operating floor**

Highest position of the hook shall be such that during operation of hoists, the vertical distance between bottom of any equipment handled and top of any permanent structure or equipment in the operating area shall be at least one metre.

**4.03.02 Approach below operating floor**

To be decided by the Bidder for safe and reliable handling of any equipment above half ton below the operating floor.

**4.04.00 Length of monorail hoist**

To be decided by the Bidder depending on the floor and machine layout. The horizontal distance between the centre line of the hoist and centre line of any installed equipment in its operating shall not be more than half metre.

**5.00.00 DESIGN AND CONSTRUCTION**

**5.01.00 All parts requiring replacement or lubrication shall be easily accessible without the need for dismantling of other equipment and structures.**

Robust construction and ample rating merging which experience has shown to be necessary shall be ensured throughout manufacture.

**5.02.00 All components of hoists of identical capacity and duty shall be interchangeable. The hoists of identical capacity and duty shall be identical in all respects unless otherwise required. The hoist design shall be such that these can be quickly removed from one monorail beam and fixed on another beam without disassembling major components.**

**5.03.00 All machinery and equipment included under this specification must be equipped with safety devices and clearances to comply with recognized standards and specification requirements.**

**5.04.00 Cast iron parts wherever used, shall conform to IS:210 - FG 260. Also no wood or other combustible materials shall be used.**

**5.05.00 Defects in material like fractures, cracks, blowholes, laminations, pitting etc. are not allowed. Rectifications of any such flaw is permissible only with the approval of the Owner.**



**WBPDCL**

**EPC Bid Document  
Sagardighi Thermal Power Project  
1x660 MW Unit No. 5, Phase - III**

- 5.06.00 Each hoist shall be permanently and legibly stamped with the tag number, manufacturer's name, safe working load, grade of load chain (where applicable), range of lift etc.
- 5.07.00 Load chain (where applicable) shall be of grade T(8) as per IS:6216 and Hand chain shall be as per IS:2429 (Part-I) grade 30.
- 5.08.00 Wheels in trolley unit travel shall be single flanged with straight/tapper/barrel shaped tread to suit the monorail. Wheels should be preferably of forged steel construction. Material of construction for wheels of traversing block and hoist gear for hoist used in hazardous areas shall be of non-ferrous material to avoid spark during operation.
- 5.09.00 All gears shall be hardened and tempered steel with machine out teeth.
- 5.10.00 Hoist (Manually Operated)
- 5.10.01 Manually operated hoists shall be of spur gear chain pulley block type. It shall be suspended from the trolley by a hook. The design of the hoist shall conform to IS:3832 (Specification for hand operated chain pulley blocks).
- The hooks and brakes of hoist shall conform to the requirements stipulated in (a) and (b) below
- a) Hooks shall conform to IS:3832. The load hook shall be swiveling type fitted with a locking device.
  - b) The pulley blocks shall be fitted with an automatic mechanical load brake to prevent self-lowering of load in all working positions. The load brake shall also allow smooth lowering of load without serious overheating.
  - c) All manually operated hoists, unless stated otherwise, shall be trolley suspended type.
- 5.10.02 The trolley of hoists shall be manually operated.
- 5.10.03 The hoists shall be of Mechanism class 2 as per IS:3832.
- 5.11.00 Electric Hoist
- 5.11.01 Electric hoist shall be electric wire rope trolley suspended type. The design, operation, testing of electric hoist shall conform to IS:3938 (Specification for electric wire rope hoist).
- Minimum speed for hoisting shall be 3 m/min. and that of for trolley motion shall be 15 m/min.
- 5.11.02 Lifting hook shall conform to IS 15560 as applicable.
- 5.11.03 Wire rope for hoists shall conform to IS-2266.



**WBPDCL**

**EPC Bid Document  
Sagardighi Thermal Power Project  
1x660 MW Unit No. 5, Phase - III**

- 5.11.04 Electro-mechanical brakes of fail to safety type shall be provided for hoist motion as well as per trolley motion for electrically driven trolley. Load brake shall allow smooth lowering of load and arrangement shall be such as it can not be released accidentally. Capacity of brake and other relevant data shall conform to IS:3938.
- 5.11.05 The trolley of the hoists shall be electrically driven.
- 5.11.06 For other components of hoist such as rope, sheave, drum, bearings, gears etc. stipulations of IS: 3938 shall be followed.
- 5.11.07 Motor shall be rated for duty S4, CDF 40% and 150 starts per hour. Service class of motor shall be "4" as per IS:3938. Conditions given in IS:3938 for hoist motor shall be followed over and above the specification of electric motor in Volume II-F1/F2.
- In case of any contradiction of the aforesaid standard and the motor specification, the conditions, which are more stringent, shall be considered. All the motors shall be suitable for reversing, frequent starting and braking. Motors shall be provided with suitable space heating arrangement.
- 5.11.08 Hoist shall be designed so that remote control can be effected by means of pendant push button switch from the operating floor. Operation, arrangement etc. of pendant push button switch shall conform to IS:3938.
- 5.11.09 Micro-speed attachment in hoist shall be provided if considered necessary by the Bidder.
- 5.11.10 The hoists shall be of mechanism class 2 as per IS-3938.
- 5.12.00 Ball and roller bearings of reputed make shall be used throughout.
- 5.13.00 Suitable lubrication system shall be provided for all gear drives.
- 5.14.00 Other Electrical Items
- 5.14.01 The cross conductor on monorail for power supply to the hoist shall be of festoon type flexible insulated cable conductors. All fixtures and accessories shall be provided by the Bidder for this purpose.
- 5.14.02 Necessary insulators, supports, clamps and all other accessories shall be provided as per standard design.
- 5.14.03 Each hoist shall be provided with a starter panel with protective relays.
- 5.14.04 One main isolating switch shall be used to cut-off the supply to the hoist assembly.
- 5.14.05 One main electro-magnetic contactor together with magnetic overload relay (hand reset) for each motor circuit shall be housed in the protection panel.



**WBPDC**

**EPC Bid Document**  
**Sagardighi Thermal Power Project**  
**1x660 MW Unit No. 5, Phase - III**

- 5.14.06 The operation of overload relay shall interrupt the main magnetic contactor.
- 5.14.07 Adequate short circuit protection shall be provided for main and individual circuits.
- 5.14.08 415V  $\pm$  10%, 3 Phase, 4 Wire, 50 Hz  $\pm$  5%, power supply for the hoist shall be arranged through switch fuse unit mounted at standing height at a convenient location near each hoist. The above switch fuse unit and the connecting cables between switch fuse unit and the cross conductor are included within the scope of this specification.
- 5.14.09 Transformers to step down the voltage and rectifiers as necessary shall be provided by the Bidder.
- 5.14.10 All external and internal power, control and auxiliary circuit wiring of the electrical drive and accessories and panels shall be provided. The wiring shall be done with 1100 V grade PVC insulated stranded aluminium conductor cable of suitable size not less than 2.5 sq.mm nominal equivalent copper area of cross-section. All control and auxiliary circuit wiring shall be done with 1100 V grade PVC insulated, 2.5 sq.mm. stranded copper conductor. Control wire terminations to the panels shall be made with compression type connectors. Multiway terminal blocks shall be furnished for terminating panel wiring and outgoing cable.
- 5.14.11 The hoist structure, motor frame and metal cases of all electrical equipment including metal conduit shall be effectively connected to earth. All grounding materials shall be supplied under this specification to grounding risers.
- 5.14.12 Single speed control shall be used for both hoist and trolley travel in each direction of motion.
- 5.15.00 Final painting at manufacturer's works shall be provided by the Bidder.

## **6.00.00 INSPECTION AND TESTING**

- 6.01.00 The manufacturer shall conduct all tests required to ensure that the equipment furnished shall conform to the requirements of the specification and in compliance with the requirements of the latest edition of IS:3832 or equivalent standards for manually operated hoists and shall be as per IS:3938 for electrically operated hoist.
- 6.02.00 All hoists performance test shall be duly certified by govt. approved agency.

## **7.00.00 DRAWINGS, DATA AND INFORMATION**

- 7.01.00 General arrangement drawings incorporating all dimensions information on head rooms, lift, wheel loads, hook suspension arrangement and other relevant data for all the hoists.





**WBPDCL**

**EPC Bid Document  
Sagardighi Thermal Power Project  
1x660 MW Unit No. 5, Phase - III**

- 7.02.00 Design calculation for selection of electric motor capacities for electric hoist.
- 7.03.00 Complete list of location, number and capacity of hoists provided.





**WBPDC**

**EPC Bid Document  
Sagardighi Thermal Power Project  
1x660 MW Unit No. 5, Phase - III**

## **ANNEXURE-I**

### **LIST OF LOCATION FOR MONORAIL HOISTS**

Hoists shall be provided for equipment/component weighing 100 kg and above where mobile equipment is not accessible to those areas.

1. Power House
  - a) For all equipment above 500 Kg in ground floor and mezzanine floor in AB bay, which do not have suitable openings in upper floors for approach of E.O.T. crane hooks.
  - b) A/C Plant Equipment Room Area.
2. Boiler Area
  - a) I.D. fan, motor.
  - b) F.D. fan, motor.
  - c) P.A. fan, motor.
  - d) Mills & gear boxes.
  - e) Air heater areas.
3. For SCR, at least 2 (two) nos. hoists each of 3 ton capacity (minimum) along with monorail to be provided for each SCR reactor.
4. E.S.P. Transformer Rectifier Sets
5. All Electrical Switch Gear Rooms
6. CW Treatment Building
7. CPU regeneration building
8. Machine room of all elevators (Power House building, boiler and mill areas, ESP & FGD absorber tower etc).
9. Chlorine ton container storage room of CW Treatment Plant.
10. For AHP area hoists, refer Vol.-II-H2, Section-I.
11. For FGD area hoists, refer Vol.-II-B, Section-V.
12. For CHP area hoists, refer Vol.-II-H1.





**TITLE:**  
**1 X 660 MW SAGARDIGHI TPS UNIT NO. 5**  
**PHASE III**

SPECIFICATION NO. PE-TS-445-155A-A001

SECTION : II

**TECHNICAL SPECIFICATION FOR**  
**CONDENSATE POLISHING UNIT**

**SUB-SECTION: IIB**

**REV. NO. 04**

**DATE : 18.04.2022**

**SECTION – II**

**SUB-SECTION IIB: GENERAL TECHNICAL REQUIREMENTS (ELECTRICAL)**

	TITLE	SPECIFICATION NO.
	LV MOTOR	VOLUME II B
	DATA SHEET – C	SECTION D
	SAGARDIGHI THERMAL POWER PROJECT 1 x 660 MW UNIT NO. 5, PHASE – III	REV NO. 00 DATE
		SHEET 1 OF 2

S. No.	Description	Data to be filled by successful bidder
<b>A.</b>	<b>General</b>	
1	Manufacturer & country of origin	
2	Motor type	
3	Type of starting	
4	Name of the equipment driven by motor & Quantity	
5	Maximum Power requirement of driven equipment	
6	Rated speed of Driven Equipment	
7	Design ambient temperature	
<b>B.</b>	<b>Design and Performance Data</b>	
1	Frame size & type designation	
2	Type of duty	
3	Rated Voltage	
4	Permissible variation for	
5	a) Voltage	
6	b) Frequency	
7	c) Combined voltage & frequency	
8	Rated output at design ambient temp (by resistance method)	
9	Synchronous speed & Rated slip	
10	Minimum permissible starting voltage	
11	Starting time in sec with mechanism coupled	
12	a) At rated voltage	
13	b) At min starting voltage	
14	Locked rotor current as percentage of FLC (including IS tolerance)	
15	Torque	
	a) Starting	
	b) Maximum	
16	Permissible temp rise at rated output over ambient temp & method	
17	Noise level at 1.0 m (dB)	
18	Amplitude of vibration	
19	Efficiency & P.F. at rated voltage & frequency	
	a) At 100% load	
	c) At 75% load	

NAME OF VENDOR			SEAL	REV.	
NAME	SIGNATURE	DATE			

	TITLE	SPECIFICATION NO.
	<b>LV MOTOR</b>	VOLUME II B
	<b>DATA SHEET – C</b>	SECTION D
	<b>SAGARDIGHI THERMAL POWER PROJECT 1 x 660 MW UNIT NO. 5, PHASE – III</b>	REV NO. 00 DATE
		SHEET 2 OF 2

S. No.	Description	Data to be filled by successful bidder
	c) At starting	
<b>C.</b>	<b>Constructional Features</b>	
1	Method of connection of motor driven equipment	
2	Applicable Standard	
3	DOP of Enclosure	
4	Method of cooling	
5	Class of insulation	
6	Main terminal box	
	a) Type	
	b) Power Cable details (Conductor, size, armour/unarmour)	
	c) Cable Gland & lugs details (Size, type & material)	
	d) Permissible Fault level ( kArms & duration in sec)	
7	Space heater details (Voltage & watts)	
8	Flame proof motor details (if applicable)	
	a) Enclosure	
	b) suitability for hazardous area	
	i Zone	O / I / II
	ii Group	IIA / IIB / IIC
9	No. of Stator winding	
10	Winding connection	
11	Kind of rotor winding	
12	Kind of bearings	
13	Direction of rotation when viewed from NDE	
14	Paint Shade & type	
15	Net weight of motor	
16	Outline mounting drawing No (To be enclosed as annexure)	
<b>D.</b>	<b>Characteristic curves/ drawings</b> (To be enclosed for motors of rating $\geq 55KW$ )	
	a) Torque speed characteristic	
	b) Thermal withstand characteristic	
	c) Current vs time	
	d) Speed vs time	

NAME OF VENDOR			SEAL	REV.	
NAME	SIGNATURE	DATE			

	<b>TITLE :</b> <b>GENERAL TECHNICAL REQUIREMENTS</b>  <b>FOR</b>  <b>LV MOTORS</b>	<b>SPECIFICATION NO.</b> PE-SS-999-506-E101 <b>VOLUME NO. : II-B</b>  <b>REV NO. : 00</b> <b>DATE : 29/08/2005</b> <b>SHEET : 1 OF 1</b>
--	---	---

**GENERAL TECHNICAL REQUIREMENTS**

**FOR**

**LV MOTORS**

**SPECIFICATION NO.: PE-SS-999-506-E101 Rev 00**

	TITLE :	SPECIFICATION NO.
	<b>GENERAL TECHNICAL REQUIREMENTS</b>	PE-SS-999-506-E101
	<b>FOR</b>	VOLUME NO. : <b>II-B</b>
	<b>LV MOTORS</b>	SECTION : <b>D</b>
		REV NO. : <b>00</b> DATE : 29/08/2005
	SHEET : 1 OF 4	

## 1.0 INTENT OF SPECIFICATION

The specification covers the design, materials, constructional features, manufacture, inspection and testing at manufacturer's work, and packing of Low voltage (LV) squirrel cage induction motors along with all accessories for driving auxiliaries in thermal power station.

Motors having a voltage rating of below 1000V are referred to as low voltage (LV) motors.

## 2.0 CODES AND STANDARDS

Motors shall fully comply with latest edition, including all amendments and revision, of following codes and standards:

IS:325	Three phase Induction motors
IS : 900	Code of practice for installation and maintenance of induction motors
IS: 996	Single phase small AC and universal motors
IS: 4722	Rotating Electrical machines
IS: 4691	Degree of Protection provided by enclosures for rotating electrical machines
IS: 4728	Terminal marking and direction of rotation rotating electrical machines
IS: 1231	Dimensions of three phase foot mounted induction motors
IS: 8789	Values of performance characteristics for three phase induction motors
IS: 13555	Guide for selection and application of 3-phase A.C. induction motors for different types of driven equipment
IS: 2148	Flame proof enclosures for electrical appliance
IS: 5571	Guide for selection of electrical equipment for hazardous areas
IS: 12824	Type of duty and classes of rating assigned
IS: 12802	Temperature rise measurement for rotating electrical machines
IS: 12065	Permissible limits of noise level for rotating electrical machines
IS: 12075	Mechanical vibration of rotating electrical machines

In case of imported motors, motors as per IEC-34 shall also be acceptable.

## 3.0 DESIGN REQUIREMENTS

3.1 Motors and accessories shall be designed to operate satisfactorily under conditions specified in data sheet-A and Project Information, including voltage & frequency variation of supply system as defined in Data sheet-A

3.2 Motors shall be continuously rated at the design ambient temperature specified in Data Sheet-A and other site conditions specified under Project Information  
Motor ratings shall have at least a 15% margin over the continuous maximum demand of the driven equipment, under entire operating range including voltage & frequency variation specified above.

### 3.3 Starting Requirements

3.3.1 Motor characteristics such as speed, starting torque, break away torque and starting time shall be properly co-ordinated with the requirements of driven equipment. The accelerating torque at any speed with the minimum starting voltage shall be at least 10% higher than that of the driven equipment.

3.3.2 Motors shall be capable of starting and accelerating the load with direct on line starting without exceeding acceptable winding temperature.

	TITLE :	SPECIFICATION NO.
	<b>GENERAL TECHNICAL REQUIREMENTS</b>	PE-SS-999-506-E101
	<b>FOR</b>	VOLUME NO. : <b>II-B</b>
	<b>LV MOTORS</b>	SECTION : <b>D</b>
		REV NO. : <b>00</b> DATE : 29/08/2005
	SHEET : 2 OF 4	

The limiting value of voltage at rated frequency under which a motor will successfully start and accelerate to rated speed with load shall be taken to be a constant value as per Data Sheet - A during the starting period of motors.

### 3.3.3 The following frequency of starts shall apply

- i) Two starts in succession with the motor being initially at a temperature not exceeding the rated load temperature.
- ii) Three equally spread starts in an hour the motor being initially at a temperature not exceeding the rated load operating temperature. (not to be repeated in the second successive hour)
- iii) Motors for coal conveyor and coal crusher application shall be suitable for three consecutive hot starts followed by one hour interval with maximum twenty starts per day and shall be suitable for minimum 20,000 starts during the life time of the motor

### 3.4 Running Requirements

3.4.1 Motors shall run satisfactorily at a supply voltage of 75% of rated voltage for 5 minutes with full load without injurious heating to the motor.

3.4.2 Motor shall not stall due to voltage dip in the system causing momentary drop in voltage upto 70% of the rated voltage for duration of 2 secs.

### 3.5 Stress During bus Transfer

3.5.1 Motors shall withstand the voltage, heavy inrush transient current, mechanical and torque stress developed due to the application of 150% of the rated voltage for at least 1 sec. caused due to vector difference between the motor residual voltage and the incoming supply voltage during occasional auto bus transfer.

3.5.2 Motor and driven equipment shafts shall be adequately sized to satisfactorily withstand transient torque under above condition.

3.6 Maximum noise level measured at distance of 1.0 metres from the outline of motor shall not exceed the values specified in IS 12065.

3.7 The max. vibration velocity or double amplitude of motors vibration as measured at motor bearings shall be within the limits specified in IS: 12075.

### 4.0 CONSTRUCTIONAL FEATURES

4.1 Indoor motors shall conform to degree of protection IP: 54 as per IS: 4691. Outdoor or semi-indoor motors shall conform to degree of protection IP: 55 as per IS: 4691 and shall be of weather-proof construction. Outdoor motors shall be installed under a suitable canopy

4.2 Motors upto 160KW shall have Totally Enclosed Fan Cooled (TEFC) enclosures, the method of cooling conforming to IC-0141 or IC-0151 of IS: 6362.

Motors rated above 160 KW shall be Closed Air Circuit Air (CACA) cooled

4.3 Motors shall be designed with cooling fans suitable for both directions of rotation.

	<b>TITLE :</b> <b>GENERAL TECHNICAL REQUIREMENTS</b>  <b>FOR</b>  <b>LV MOTORS</b>	<b>SPECIFICATION NO.</b> PE-SS-999-506-E101
		<b>VOLUME NO. : II-B</b>
		<b>SECTION : D</b>
		<b>REV NO. : 00 DATE : 29/08/2005</b>
		<b>SHEET : 3 OF 4</b>
<p>4.4. Motors shall not be provided with any electric or pneumatic operated external fan for cooling the motors.</p> <p>4.5 Frames shall be designed to avoid collection of moisture and all enclosures shall be provided with facility for drainage at the lowest point.</p> <p>4.6 In case Class ‘F’ insulation is provided for LV motors, temperature rise shall be limited to the limits applicable to Class ‘B’ insulation. In case of continuous operation at extreme voltage limits the temperature limits specified in table-1 of IS:325 shall not exceed by more than 10°C.</p> <p><b>4.7 Terminals and Terminal Boxes</b></p> <p>4.7.1 Terminals, terminal leads, terminal boxes, windings tails and associated equipment shall be suitable for connection to a supply system having a short circuit level, specified in the Data Sheet-A.</p> <p>Unless otherwise stated in Data Sheet-A, motors of rating 110 kW and above will be controlled by circuit breaker and below 110 kW by switch fuse-contactor. The terminal box of motors shall be designed for the fault current mentioned in data sheet “A”.</p> <p>4.7.2 unless otherwise specified or approved, phase terminal boxes of horizontal motors shall be positioned on the left hand side of the motor when viewed from the non-driving end.</p> <p>4.7.3 Connections shall be such that when the supply leads R, Y &amp; B are connected to motor terminals A B &amp; C or U, V &amp; W respectively, motor shall rotate in an anticlockwise direction when viewed from the non-driving end. Where such motors require clockwise rotation, the supply leads R, Y, B will be connected to motor terminals A, C, B or U W &amp; V respectively.</p> <p>4.7.4 Permanently attached diagram and instruction plate made preferably of stainless steel shall be mounted inside terminal box cover giving the connection diagram for the desired direction of rotation and reverse rotation.</p> <p>4.7.5 Motor terminals and terminal leads shall be fully insulated with no bar live parts. Adequate space shall be available inside the terminal box so that no difficulty is encountered for terminating the cable specified in Data Sheet-A.</p> <p>4.7.6 Degree of protection for terminal boxes shall be IP 55 as per IS 4691.</p> <p>4.7.7 Separate terminal boxes shall be provided for space heaters.. If this is not possible in case of LV motors, the space heater terminals shall be adequately segregated from the main terminals in the main terminal box. Detachable gland plates with double compression brass glands shall be provided in terminal boxes.</p> <p>4.7.8. Phase terminal boxes shall be suitable for 360 degree of rotation in steps of 90 degree for LV motors.</p> <p>4.7.9 Cable glands and cable lugs as per cable sizes specified in Data Sheet-A shall be included. Cable lugs shall be of tinned Copper, crimping type.</p> <p>4.8 Two separate earthing terminals suitable for connecting G.I. or MS strip grounding conductor of size given in Data Sheet-A shall be provided on opposite sides of motor frame. Each terminal box shall have a grounding terminal.</p> <p><b>4.9 General</b></p>		

	<b>TITLE :</b> <b>GENERAL TECHNICAL REQUIREMENTS</b>  <b>FOR</b>  <b>LV MOTORS</b>	SPECIFICATION NO. PE-SS-999-506-E101
		VOLUME NO. : <b>II-B</b>
		SECTION : <b>D</b>
		REV NO. : <b>00</b> DATE : 29/08/2005
		SHEET : 4 OF 4

- 4.9.1 Motors provided for similar drives shall be interchangeable.
- 4.9.2 Suitable foundation bolts are to be supplied alongwith the motors.
- 4.9.3 Motors shall be provided with eye bolts, or other means to facilitate safe lifting if the weight is 20Kgs. and above.
- 4.9.4 Necessary fitments and accessories shall be provided on motors in accordance with the latest Indian Electricity rules 1956.
- 4.9.5 All motors rated above 30 kW shall be provided with space heaters to maintain the motor internal air temperature above the dew point. Unless otherwise specified, space heaters shall be suitable for a supply of 240V AC, single phase, 50 Hz.
- 4.9.6 Name plate with all particulars as per IS: 325 shall be provided
- 4.9.7 Unless otherwise specified, the colour of finish shall be grey to Shade No. 631 and 632 as per IS:5 for motors installed indoor and outdoor respectively. The paint shall be epoxy based and shall be suitable for withstanding specified site conditions.
- 5.0 INSPECTION AND TESTING**
- 5.1 All materials, components and equipments covered under this specification shall be procured, manufactured, as per the BHEL standard quality plan No. PED-506-00-Q-006/0 and PED-506-00-Q-007/2 enclosed with this specification and which shall be complied.
- 5.2 LV motors of type-tested design shall be provided. Valid type test reports not more than 5 year shall be furnished. In the absence of these, type tests shall have to be conducted by manufacturer without any commercial implication to purchaser.
- 5.3 All motors shall be subjected to routine tests as per IS: 325 and as per BHEL standard quality plan.
- 5.4 Motors shall also be subjected to additional tests, if any, as mentioned in Data Sheet A.
- 6.0 DRAWINGS TO BE SUBMITTED AFTER AWARD OF CONTRACT**
- a) OGA drawing showing the position of terminal boxes, earthing connections etc.
- b) Arrangement drawing of terminal boxes.
- c) Characteristic curves:  
(To be given for motor above 55 kW unless otherwise specified in Data Sheet).
- i) Current vs. time at rated voltage and minimum starting voltage.
- ii) Speed vs. time at rated voltage and minimum starting voltage.
- iii) Torque vs. speed at rated voltage and minimum voltage.  
For the motors with solid coupling the above curves i), ii), iii) to be furnished for the motors coupled with driven equipment. In case motor is coupled with mechanical equipment by fluid coupling, the above curves shall be furnished with and without coupling.
- iv) Thermal withstand curve under hot and cold conditions at rated voltage and max. permissible voltage.

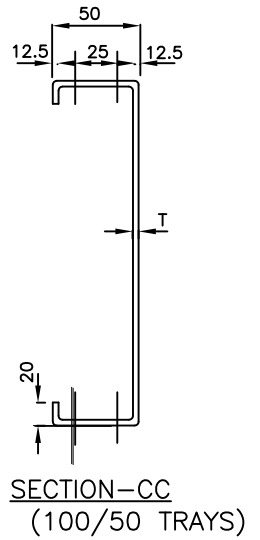
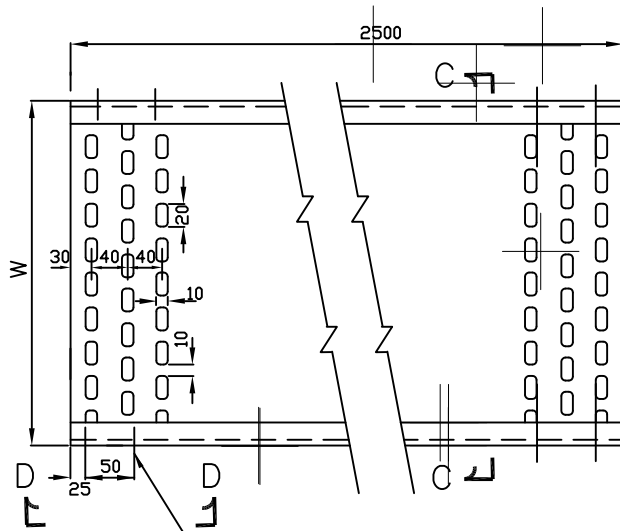

4 HOLES 10mm DIA.

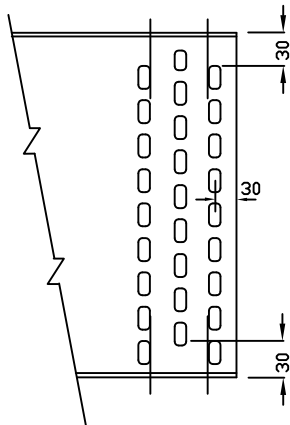

ARRANGEMENT OF PERFORATIONS

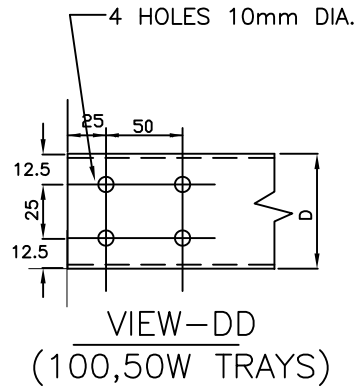

TRAY WIDTH W (mm)	100	50
TRAY DEPTH D (mm)	50	50
T (mm)	2	2

PERFORATED TYPE TRAY



TYPICAL DETAILS OF CABLE TRAYS AND ACCESSORIES

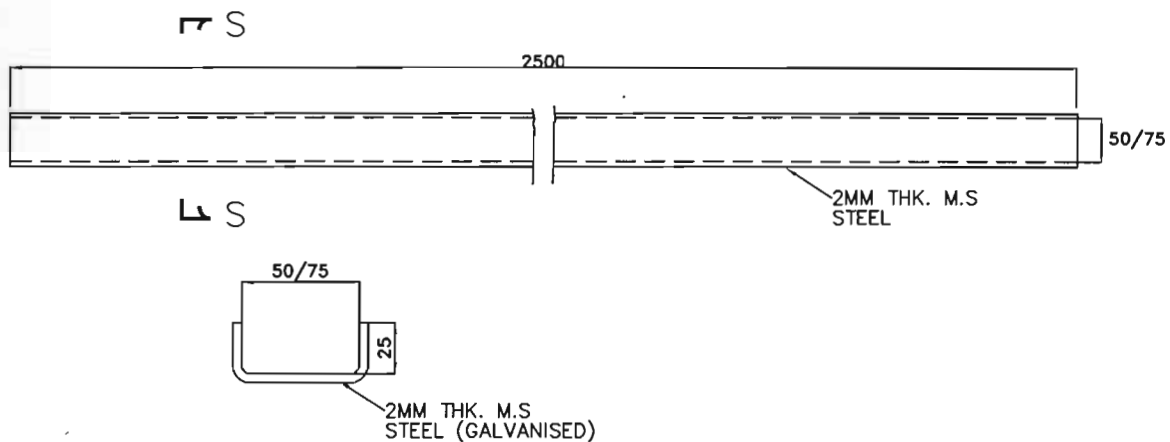

SECTION S-S

CABLE TROUGHS



TYPICAL DETAILS OF  
CABLE TRAY AND ACCESSORIES



**TITLE:**  
**1 X 660 MW SAGARDIGHI TPS UNIT NO. 5**  
**PHASE III**

SPECIFICATION NO. PE-TS-445-155A-A001

SECTION : II

**TECHNICAL SPECIFICATION FOR**  
**CONDENSATE POLISHING UNIT**

**SUB-SECTION: IIC**

**REV. NO. 02**

**DATE : 18.04.2022**

**SECTION – II**

**SUB-SECTION IIC: GENERAL TECHNICAL REQUIREMENTS (C&I)**

FORM NO. PEM-6666-0

	<b>SPECIFICATION FOR CONTROL &amp; INSTRUMENTATION FOR AUX PACKAGES</b>	SPECIFICATION NO.:	
		VOLUME	
		SUB SECTION	
		REV. NO.	DATE :
		SHEET	OF

**GENERAL REQUIREMENT**

1.0 Bidder shall provide complete and independent control & instrumentation system with all accessories, auxiliaries and associated equipments for the safe, efficient and reliable operation of auxiliary systems.

2.0 The quantity of instruments for auxiliary system shall be as per tender P & ID wherever provided of the respective system as a minimum, for bidding purpose. However, Bidder shall also include in his proposal all the instruments and devices that are needed for the completeness of the plant auxiliary system/ equipment supplied by the bidder, even if the same is not specifically appearing in the P & ID. During detail engineering if any additional instruments are required for safe & reliable operation of plant, bidder shall supply the same without any price implication.

3.0 Measuring instruments/equipment and subsystems offered by the bidder shall be from reputed experienced manufacturers of specified type and range of equipment, whose guaranteed and trouble free operation has been proven. Further all the instruments shall be of proven reliability, accuracy, and acceptable international standards and shall be subject to employer's approval. All instrumentation equipment and accessories under this specification shall be furnished as per technical specification, ranges, makes/ numbers as approved by the employer' during detail engineering.

4.0 The necessary root valves, impulse piping, drain cocks, gauge-zeroing cocks, valve manifold and all the other accessories required for mounting/ erection of these local instruments shall be furnished, even if not specifically asked for, on as required basis. The contacts of equipment mounted instruments; sensors, switches etc for external connection including spare contacts shall be wired out to suitably located junction boxes.

5.0 The customer specification attached as Specific Technical Requirement will supercede the Data sheets, if there is any mismatch.



**C&I SPECIFICATION FOR  
CONDENSATE POLISHING UNIT**

SECTION: C  
SUB SECTION: C&I

**LIST OF DOCUMENTS/DELIVERABLES**

|



## C&I SPECIFICATION FOR CONDENSATE POLISHING UNIT

SECTION: C  
SUB SECTION: C&I

### LIST OF DELIVERABLES OF PEM - C&I DEPARTMENT

Sl. No.	DRAWING NO.	DRAWING/DOCUMENT TITLE	CATEGORY
1	PE-V0-445-145-I901	CONTROL & OPERATIONAL WRITE-UP FOR THE SYSTEM WITH SET POINTS	A
2	PE-V0-445-145-I902	CONTROL SCHEME/LOGIC DIAGRAM (TO BE IMPLEMENTED IN DDCMIS)	A
3	PE-V0-445-145-I903	HMI PICTURES/PLANT SCHEMATICS	A
4	PE-V0-445-145-I904	INSTRUMENT SCHEDULE WITH SET POINTS	A
5	PE-V0-445-145-I905	I/O LIST (ANALOG & BINARY)	A
6	PE-V0-445-145-I906	DRIVE LIST/SOLENOID/ACTUATOR VALVE LIST WITH LOCATION DATA	A
7	PE-V0-445-145-I907	FIELD JB/LIE/LIR,DRIVES TERMINATIONS	A
8	PE-V0-445-145-I908	DATASHEETS FOR INSTRUMENTS, JBs, etc.	A
9	PE-V0-445-145-I909	QUALITY PLANS (INSTRUMENTS, VMS, etc.)	A
10	PE-V0-445-145-I910	INSTRUMENT HOOK-UP DRAWING	A
11	PE-V0-445-145-I911	THERMOWELL SIZING CALCULATION	A
12	PE-V0-445-145-I913	CABLE SCHEDULE & INTERCONNECTION	A
13	PE-V0-445-145-I914	ANNUNCIATION & SOE LIST	A

**NOTES:**

ANY OTHER DOCUMENT DECIDED DURING DETAILED ENGINEERING SHALL BE PROVIDED BY BIDDER WITHOUT ANY COMMERCIAL/TECHNICAL IMPLICATION.

CONTRACTOR TO SUBMIT REUSABLE DATABASE FORMATS IN BHEL/CUSTOMER APPROVED FORMATS LIKE MS EXCEL, MS ACCESS OF DOCUMENTS LIKE INSTRUMENT SCHEDULE, I/O LIST, DRIVE LIST, FIELD JB TERMINATIONS, CABLE SCHEDULE & INTERCONNECTION, etc. SOFT COPY OF FORMATS SHALL BE PROVIDED TO SUCCESSFUL BIDDERS.



**C&I SPECIFICATION FOR  
CONDENSATE POLISHING UNIT**

SECTION: C  
SUB SECTION: C&I

**MOTORISED VALVE ACTUATOR**

|



**SPECIFICATION  
FOR  
MOTORISED VALVE ACTUATOR**

DOCUMENT NO.: PE-ID-445-145-I902

VOLUME II B

SECTION D

REV. NO. 01

DATE:27/03/2020

SHEET 1 OF 5

**Data Sheet A & B**

DATA SHEET-A  
(TO BE FILLED BY PURCHASER)

DATA SHEET-B  
(TO BE FILLED-UP BY BIDDER)

<b>GENERAL*</b>	* PROJECT	1 X 660 MW SAGARDIGHI STPP
	OFFER REFERENCE	
	* TAG NO. SERVICE	
	* DUTY	<input type="checkbox"/> ON / OFF <input type="checkbox"/> INCHING
	* LINE SIZE (inlet/outlet): MATERIAL	
	* VALVE TYPE	<input type="checkbox"/> GLOBE <input type="checkbox"/> GATE <input type="checkbox"/> REG. GLOBE <input type="checkbox"/> BUTTERFLY
	* OPENING / CLOSING TIME	
	* WORKING PRESSURE	
	AMBIENT CONDITION	SHALL BE SUITABLE FOR CONTINUOUS OPERATION UNDER AN AMBIENT TEMP. OF -20 to 70 DEG C AND RELATIVE HUMIDITY OF 0-95% IN HOT HUMID AND TROPICAL ATMOSPHERE AND HIGHLY POLLUTED AT PLACES OF COAL DUST AND FLY DUST
	VALVE SEAT TEST PRESS	BIDDER TO SPECIFY
	REQUIRED VALVE TORQUE	BIDDER TO SPECIFY
	ACTUATOR RATED TORQUE	BIDDER TO SPECIFY
<b>CONSTRUCTION AND SIZING</b>	CONSTRUCTION	TOTALLY ENCLOSED, WEATHER PROOF, DUST TIGHT SUITABLE FOR OUTDOOR USE WITHOUT CANOPY, NEMA6/IP:68
	MECHANICAL POSITION INDICATOR	TO BE PROVIDED FOR 0-100% TRAVEL
	BEARINGS	DOUBLE SHIELDED, GREASE LUBRICATED ANTI-FRICTION.
	GEAR TRAIN FOR LIMIT SWITCH/TORQUE SWITCH OPERATION	METAL (NOT FIBRE GEARS). SELF-LOCKING TO PREVENT DRIFT UNDER TORQUE SWITCH SPRING PRESSURE WHEN MOTOR IS DE-ENERGIZED.
	SIZING	OPEN/CLOSE AT RATED SPEED AGAINST DESIGNED DIFFERENTIAL PRESSURE AT 85% OF RATED VOLTAGE. FOR ISOLATING SERVICE THREE SUCCESSIVE OPEN-CLOSE OPERATIONS OR 15 MINS. WHICHEVER IS HIGHER. <b>FOR INCHING SERVICE - 150 STARTS/HR MINIMUM &amp; FOR REGULATING SERVICE - 600 STARTS/HR MINIMUM as per IEC60034-1</b>
<b>HANDWHEEL as per standard EN 12570:2000</b>	* REQUIRED	<input checked="" type="checkbox"/> YES <input type="checkbox"/> NO
	* ORIENTATION	<input type="checkbox"/> TOP MOUNTED <input type="checkbox"/> SIDE MOUNTED
	*TO DISENGAGE AUTOMATICALLY DURING MOTOR OPERATION.	
<b>ELECTRIC ACTUATOR</b>	ACTUATOR MAKE/MODEL	BIDDER TO SPECIFY
	MOTOR MAKE / MODEL / TYPE / RATING (KW) (REFER NOTE NO. 6 & 7)	BIDDER TO SPECIFY
	@ MOTOR TYPE	SQUIRREL CAGE INDUCTION MOTOR, STARTING CURRENT LIMITED TO SIX TIMES THE RATED CURRENT-INCLUSIVE OF I.S. TOLERANCE
	ACTUATOR APPLICABLE WIRING DIAGRAM	<input checked="" type="checkbox"/> ENCLOSED (BIDDER TO CONFIRM) A: <input checked="" type="checkbox"/> DRG. NO. 3-V-MISC-24227 R00 B: <input type="checkbox"/> DRG. NO. 3-V-MISC-24550 R00 C: <input type="checkbox"/> DRG. NO. 3-V-MISC-24283 R00 D: <input type="checkbox"/> DRG. NO. 4-V-MISC-90271 R11 E: <input type="checkbox"/> For Thyristor based Integral starter, Bidder/Vendor to furnish wiring diagram
	COLOUR SHADE	<input type="checkbox"/> BLUE (RAL 5012) <input type="checkbox"/> ..... <input checked="" type="checkbox"/> TO BE DECIDED DURING DETAILED ENGINEERING
	PAINT TYPE	<input type="checkbox"/> ENAMEL <input checked="" type="checkbox"/> EPOXY CONFIRMING TO CORROSION CATEGORY C5-I
	SHAFT RPM	BIDDER TO SPECIFY
	OLR SET VALUE	BIDDER TO SPECIFY



**SPECIFICATION  
FOR  
MOTORISED VALVE ACTUATOR**

DOCUMENT NO.: PE-ID-445-145-I902

VOLUME II B

SECTION D

REV. NO. 01

DATE:27/03/2020

SHEET 2

OF 5

**Data Sheet A & B**

DATA SHEET-A  
(TO BE FILLED BY PURCHASER)

DATA SHEET-B  
(TO BE FILLED-UP BY BIDDER)

	@ STARTING / FULL LOAD CURRENT	BIDDER TO SPECIFY	
	NO. OF REV FOR FULL TRAVEL	BIDDER TO SPECIFY	
	@ PWR SUPP TO MTR / STARTER	415V, 3PH, AC	
	@ CONTROL VOLTAGE REQUIREMENT	TO BE DERIVED FROM THE POWER SUPPLY TO THE STARTER <input type="checkbox"/> 230 V <input type="checkbox"/> 110 V	
	@ ENCLOSURE CLASS OF MOTOR	<input type="checkbox"/> IP 67 <input checked="" type="checkbox"/> IP 68 <input type="checkbox"/> FLAME PROOF	
	@MOTOR BEARING WITH 2 EARTH TERMINALS	DOUBLE SHIELDED; GREASE LUBRICATED ANTI FRICTION	
	@ INSULATION CLASS	CLASS-F TEMP. RISE LIMITED TO CLASS-B	
	@ WINDING TEMP PROTECTION	<input checked="" type="checkbox"/> THERMOSTAT (3 Nos.,1 IN EACH PHASE)	
	SINGLE PHASE / WRONG PHASE SEQUENCE PROTECTION	REQUIRED (THERMISTOR PTC)	
<b>INTEGRAL STARTER</b>	INTEGRAL STARTER	<input checked="" type="checkbox"/> REQUIRED <input type="checkbox"/> NOT REQUIRED	
	TYPE OF SWITCHING DEVICE	<input checked="" type="checkbox"/> CONTACTORS <input type="checkbox"/> THYRISTORS	
	TYPE	<input checked="" type="checkbox"/> CONVENTIONAL <input type="checkbox"/> SMART (NON-INTRUSIVE)	
	<b>IF SMART (REFER BELOW POINT a – h )</b>		
	a) SERIAL LINK INTERFACE	<input type="checkbox"/> INTEGRAL <input type="checkbox"/> FIELD MOUNTED	
	b) SERIAL LINK PROTOCOL	<input type="checkbox"/> FOUNDATION FIELD-BUS <input type="checkbox"/> PROFI-BUS <input type="checkbox"/> DEVICE NET <input type="checkbox"/> .....	
	c) SERIAL LINK MEDIA	<input type="checkbox"/> TWISTED PAIR Cu-CBL <input type="checkbox"/> CO-AXIAL Cu-CBL <input type="checkbox"/> OFC	
	d) HAND HELD PROGRAMMER	<input type="checkbox"/> REQUIRED <input type="checkbox"/> NOT REQUIRED	
	e) TYPE OF HAND HELD PROGRAMMER	<input type="checkbox"/> BLUETOOTH <input type="checkbox"/> INFRARED <input type="checkbox"/> .....	
	f) MASTER STATION	<input type="checkbox"/> REQUIRED <input type="checkbox"/> NOT REQUIRED	
	g) MASTER STN INTRFACE WITH DCS	<input type="checkbox"/> MODBUS <input type="checkbox"/> TCP/IP	
	h) DETAILS OF SPECIAL CABLE	<input type="checkbox"/> ENCLOSED <input type="checkbox"/> NOT REQUIRED	
	STEP DOWN CONT. TRANSFORMER	<input checked="" type="checkbox"/> REQUIRED	
	OPEN / CLOSE PB	<input checked="" type="checkbox"/> REQUIRED <input type="checkbox"/> NOT REQUIRED	
	STOP PB	<input checked="" type="checkbox"/> REQUIRED <input type="checkbox"/> NOT REQUIRED	
	INDICATING LAMPS	<input checked="" type="checkbox"/> REQUIRED <input type="checkbox"/> NOT REQUIRED	
	LOCAL REMOTE S/S	<input checked="" type="checkbox"/> REQUIRED <input type="checkbox"/> NOT REQUIRED	
	STATUS CONTACTS FOR MONITORING	<input checked="" type="checkbox"/> REQUIRED <input type="checkbox"/> NOT REQUIRED	
	INTEGRAL STARTER DISTURBED SIGNAL(Refer Note 14)	REQUIRED MOTOR THERMOSTTTRIP O/L RELAY OPTD, CONT./POWER SUPPLY FAILED, S/S IN LOCAL/REMOTE/OFF MODE, TORQUE SWITCH OPEN/CLOSE CUT OFF/STOP PB OPTD, VALVE JAMMED ETC)	
	ACTION ON LOSS OF EXTERNAL ELECTRIC POWER	<input checked="" type="checkbox"/> STAYPUT <input checked="" type="checkbox"/> FAIL SAFE TO BE DECIDED DURING DETAILED ENGINEERING	
<b>INTERPOSING RELAY/OPTO COUPLER</b> (Applicable for integral Starter) <b>DATASHEET &amp; WIRING DIAGRAM OF ISOLATION DEVICE TO BE PROVIDED</b>	TYPE OF ISOLATING DEVICE	<input checked="" type="checkbox"/> INTERPOSING RELAY <input type="checkbox"/> OPTO COUPLER TO BE DECIDED DURING DETAILED ENGINEERING	
	QUANTITY	<input type="checkbox"/> 2 NOs. <input checked="" type="checkbox"/> 3 NOs.	
	DRIVING VOLTAGE	<input checked="" type="checkbox"/> 20.5 – 24V DC <input type="checkbox"/> _____ V DC	
	DRIVING CURRENT	<input checked="" type="checkbox"/> 125mA MAX <input type="checkbox"/> _____ mA MAX	
	LOAD RESISTANCE	<input checked="" type="checkbox"/> > 192 ohms - <25 k ohms <input type="checkbox"/> > _____ ohms - < _____ ohms	



**SPECIFICATION  
FOR  
MOTORISED VALVE ACTUATOR**

DOCUMENT NO.: PE-ID-445-145-I902

VOLUME II B

SECTION D

REV. NO. 01

DATE:27/03/2020

SHEET 3 OF 5

**Data Sheet A & B**

DATA SHEET-A  
(TO BE FILLED BY PURCHASER)

DATA SHEET-B  
(TO BE FILLED-UP BY BIDDER)

<b>TORQUE SWITCH</b> (Not Applicable for Smart Actuator) (\$\$ Refer Notes)	MFR & MODEL NO.	BIDDER TO SPECIFY		
	OPEN / CLOSE	■1 No. □2Nos. / ■1 No. □2Nos		
	CONTACT TYPE	2 NO + 2 NC		
	RATING	5A 240V AC AND 0.5A 220V DC		
	CALIBRATED KNOBS(OPEN&CLOSE TS)	REQUIRED FOR SETTING DESIRED TORQUE		
	ACCURACY	+3% OF SET VALUE		
<b>LIMIT SWITCH</b> (Not Applicable for Smart Actuator) (\$\$ Refer Notes)	MFR & MODEL NO.	BIDDER TO SPECIFY		
	OPEN : INT : CLOSE	□1 No. ■2 Nos.	2 Nos. (ADJ.)	□1 No. ■2Nos.
	CONTACT TYPE	2 NO + 2 NC		
	RATING (AC / DC)	5A 240V AC AND 0.5A 220V DC		
	ACCURACY	2% OF SET VALUE		
<b>POSITION TRANSMITTER</b>	POSITION TRANSMITTER (For inching duty & other specific applications**)	■ REQUIRED □ NOT REQUIRED		
	MFR & MODEL NO.	BIDDER TO SPECIFY		
	TYPE	□ ELECTRONIC (2 WIRE) R/I CONVERTER ■ ELECTRONIC (2 WIRE) CONTACTLESS		
	SUPPLY	■ 24V DC □ .....		
	OUTPUT	■ 4-20mA		
	ACCURACY	± 1% FS		
<b>SPACE HEATER</b>	@SPACE HEATER	REQUIRED		
	@ POWER SUPPLY (NON INTEGRAL)	230V AC,1 PH.,50 Hz		
	@ POWER SUPPLY (INTEGRAL)	BIDDER TO SPECIFY		
	@ RATING			
<b>TERMINAL BOX</b>	ACTUATOR/MOTOR TERMINAL BOX	REQUIRED		
	ENCL CLASS ACTUATOR/MOTOR T.B.	@ ■ IP 68	@□.....	
	@ EARTHING TERMINAL	REQUIRED		
	PLUG & SOCKET	□ REQUIRED ■ NOT REQUIRED		
	NO. OF PINS REQUIRED(TO BE CHECKED AS PER SIGNALS IN DRIVE CONTROL PHILOSOPHY)			
	NOS. OF PLUG & SOCKET	□ 1 Nos. for ON/OFF □ 2 NOS.(for inching duty) □ OTHER (TO BE SPECIFIED INLINE WITH DRIVE CONTROL PHILOSOPHY)		
<b>CABLE GLANDS</b>	@ POWER CABLE GLAND	SIZE:-----		
	@ SPACE HEATER CABLE GLAND	SIZE:-----		
	CONTROL CABLE GLANDS-1	CABLE GLAND SUITABLE FOR INSTRUMENTATION CABLE SIZE OF 4P X 1.5 SQMM		
	CONTROL CABLE GLANDS-2	CABLE GLAND SUITABLE FOR INSTRUMENTATION CABLE SIZE OF 8P X 0.5 SQMM		
	CONTROL CABLE GLANDS-3 (Additional for inching duty)	CABLE GLAND SUITABLE FOR INSTRUMENTATION CABLE SIZE OF 2P X 0.5 SQMM		
<b>WEIGHT</b>	TOTAL WEIGHT (ACTUATOR + ACCESSORIES)	BIDDER TO SPECIFY		_____ Kg.

	<b>SPECIFICATION FOR MOTORISED VALVE ACTUATOR</b>	DOCUMENT NO.: PE-ID-445-145-I902		
		VOLUME	II B	
		SECTION	D	
		REV. NO.	01	DATE:27/03/2020
		SHEET	4	OF 5

**Data Sheet A & B**

DATA SHEET-A (TO BE FILLED BY PURCHASER)	DATA SHEET-B (TO BE FILLED-UP BY BIDDER)
---	---

**NOTES:**

1. **SCOPE:** DESIGN, MANUFACTURE, INSPECTION, TESTING AND DELIVERY TO SITE OF ELECTRIC ACTUATOR FOR INCHING OR OPEN / CLOSE DUTY.
2. **CODES & STANDARDS:** DESIGN AND MATERIALS USED SHALL COMPLY WITH THE RELEVANT LATEST NATIONAL AND INTERNATION STANDARD. AS A MINIMUM, THE FOLLOWING STANDARDS SHALL BE COMPLIED WITH:  
IS-9334, IS-2147, IS-2148, IS-325, IS-2959, IS-4691, IS-4722, IEC 60947-5-1 AND EN 15714-3 :2010 OR LATEST VERSION.
3. TEMPERATURE RISE SHALL BE RESTRICTED TO 70 DEG. C FOR AMBIENT TEMPERATURE OF 50 DEG C.
4. CABLE GLANDS OF DOUBLE COMPRESSION TYPE, BRASS MATERIAL SHALL BE PROVIDED.
5. THE TORQUE SWITCHES SHALL BE PROVIDED WITH MECHANICAL LATCHING DEVICE TO PREVENT OPERATION WHEN UNSEATING FROM THE END POSITIONS. THE LATCHING DEVICE SHALL UNLATCH AS SOON AS THE VALVE LEAVES THE END POSITION. IF SUCH PROVISION IS NOT POSSIBLE, THE TORQUE SWITCHES SHALL BE BYPASSED BY END-POSITION LIMIT SWITCHES WHICH OPENS ON VALVE LEAVING END POSITION.THESE LIMIT SWITCHES ARE ADDITIONAL TO THE NUMBER OF LIMIT SWITCHES SPECIFIED ELSEWHERE.
6. THE MOTOR SHALL BE SUITABLE FOR DIRECT ON LINE STARTING.
7. THE MOTOR SHALL BE CAPABLE OF STARTING AT 85 PERCENT OF RATED VOLTAGE RUNNING AT 80 PERCENT OF RATED VOLTAGE AT RATED TORQUE AND 85 PERCENT RATED VOLTAGE AT 33 PERCENT EXCESS RATED TORQUE FOR A PERIOD OF 5 MINUTES EACH.
8. IN ADDITION TO ABOVE REQUIREMENTS FOR LIMIT/TORQUE SWITCH, **MECHANICAL END STOP** WITH ACCURACY OF 2% SHALL BE SUPPLIED.
9. IT SHOULD BE POSSIBLE TO OPERATE THE ACTUATOR LOCALLY. LOCKABLE LOCAL/REMOTE SELECTION SHALL BE PROVIDED ON THE ACTUATOR.
10. LOCAL POSITION INDICATOR SHALL BE PROVIDED FOR 0 TO 100 % TRAVEL.
11. CONTROL WIRING SHALL BE SUITABLE VOLTAGE GRADE COPPER WIRE 1.5 SQ. MM.
12. ENDURANCE: RATED TORQUE RANGE SHOULD BE BASED ON ISO 5211, ISO5210.
13. TAG PLATE SHALL BE CONFIRMING TO STANDARD BS-15714.
14. THE ACTUATORS SHALL BE DESIGNED TO BE SELF-LOCKING UPON LOSS OF POWER. MOTOR SHALL BE DESIGNED TO CLOSE IN 30 SECS. FROM FULL OPEN POSITION AND SHALL HAVE ADEQUATE CAPACITY TO OPEN AND CLOSE UNDER FULL UNBALANCED DESIGN PRESSURE.
15. AUTOMATIC PHASE CORRECTION FACILITY AND POTENTIAL FREE CONTACT FOR ANNUNCIATION OF POWER FAILURE SHALL BE PROVIDED.
16. LIMIT SWITCHES SHALL BE SILVER PLATED WITH HIGH CONDUCTIVITY AND NON-CORROSIVE TYPE. CONTACT RATING SHALL BE SUFFICIENT TO MEET THE REQUIREMENT OF CONTROL SYSTEM SUBJECT TO A MINIMUM OF 60 V, 6 VA RATING. PROTECTION CLASS SHALL BE IP67.
17. THE TERMINAL BOX SHALL BE WEATHER PROOF WITH REMOVABLE FRONT COVER & CABLE GLANDS FOR CABLE CONNECTION.IT SHALL BE SUITABLE FOR 2.5 SQ MM COPPER CONDUCTOR.
18. ACTUATOR SHALL ATTAIN FULL SPEED OPERATIONS BEFORE VALVE LOAD IS ENCOUNTERED AND IMPART AN UNSEATING BLOW TO START THE VALVE IN MOTION (HAMMER BLOW EFFECT).
19. **\*\* VALVES WITH 10 DEGREE/20DEGREE FEEDBACK REQUIREMENT FOR APPLICATIONS SUCH AS CW/ACW/PLANT WATER SYSTEM SHALL BE CONSIDERED AS INCHING DUTY VALVES. ACCORDINGLY, POSITION FEED BACK TRANSMITTER, PLUG & SOCKET REQUIREMENT SHALL BE CONSIDERED.**

**\$\$ TORQUE SWITCH & LIMIT SWITCH SHALL ACT INDEPENDENT OF EACH OTHER. TANDEM OPERATION IS NOT ACCEPTABLE.**

	PREPARED BY	CHECKED BY	APPROVED BY	VENDOR COMPANY SEAL
NAME	ANJALI RAMAN	VIPUL KUMAR VERMA	SURESH CHAND SHARMA	NAME
SIGNATURE				SIGNATURE
DATE	27.03.2020	27.03.2020	27.03.2020	DATE

NOTES\* = TO BE FILLED BY MPL (LEAD AGENCY). @ BE FILLED BY ES

	<b>SPECIFICATION FOR MOTORISED VALVE ACTUATOR</b>	DOCUMENT NO.: PE-ID-445-145-I902		
		VOLUME	II B	
		SECTION	D	
		REV. NO.	01	DATE:27/03/2020
		SHEET	5	OF 5
<b>Data Sheet A &amp; B</b>				
DATA SHEET-A (TO BE FILLED BY PURCHASER)		DATA SHEET-B (TO BE FILLED-UP BY BIDDER)		

**ADDITIONAL NOTES FOR SAGARDIGHI PROJECT:**

- TEST WITNESS: TESTS SHALL BE PERFORMED IN THE PRESENCE OF OWNER/PURCHASER'S REPRESENTATIVE SO DESIRED BY THE OWNER/ PURCHASER. THE CONTRACTOR SHALL GIVE AT LEAST FIFTEEN (15) DAYS ADVANCE NOTICE OF THE DATE WHEN THE TESTS ARE TO BE CARRIED OUT.
- ADVANCE NOTICE SHALL BE GIVEN TO THE OWNER AS AGREED IN THE CONTRACT, PRIOR TO THE STAGE OF MANUFACTURE BEING REACHED, AND THE PIECE OF PLANT MUST BE HELD AT THIS STAGE UNTIL THE OWNER HAS INSPECTED THE PIECE, OR HAS ADVISED IN WRITING THAT INSPECTION IS WAIVED, IF HAVING CONSULTED THE OWNER AND GIVEN REASONABLE NOTICE IN WRITING OF THE DATE ON WHICH THE PIECE OF PLANT WILL BE AVAILABLE FOR INSPECTION, THE OWNER DOES NOT ATTEND, THE SUCCESSFUL BIDDER MAY PROCEED WITH MANUFACTURE HAVING FORWARDED TO THE OWNER DULY CERTIFIED COPIES OF HIS OWN INSPECTION AND TEST RESULTS.
- ACTUATOR SHALL ATTAIN FULL SPEED OPERATIONS BEFORE VALVE LOAD IS ENCOUNTERED AND IMPART AN UNSEATING BLOW TO START THE VALVE IN MOTION (HAMMER BLOW EFFECT).
- A SPACE HEATER SHALL BE INCLUDED IN THE LIMIT SWITCH COMPARTMENT SUITABLE FOR 240V, 1 PHASE, 50 HZ SUPPLY.

ALL DIMENSIONS ARE IN MILLIMETRES. FOR TOLERANCES OF UNTOLERANCED DIMENSIONS DURING MANUFACTURE REFER RELEVANT QCP / QP.

3-V-MISC-24227  
DRAWING NO.

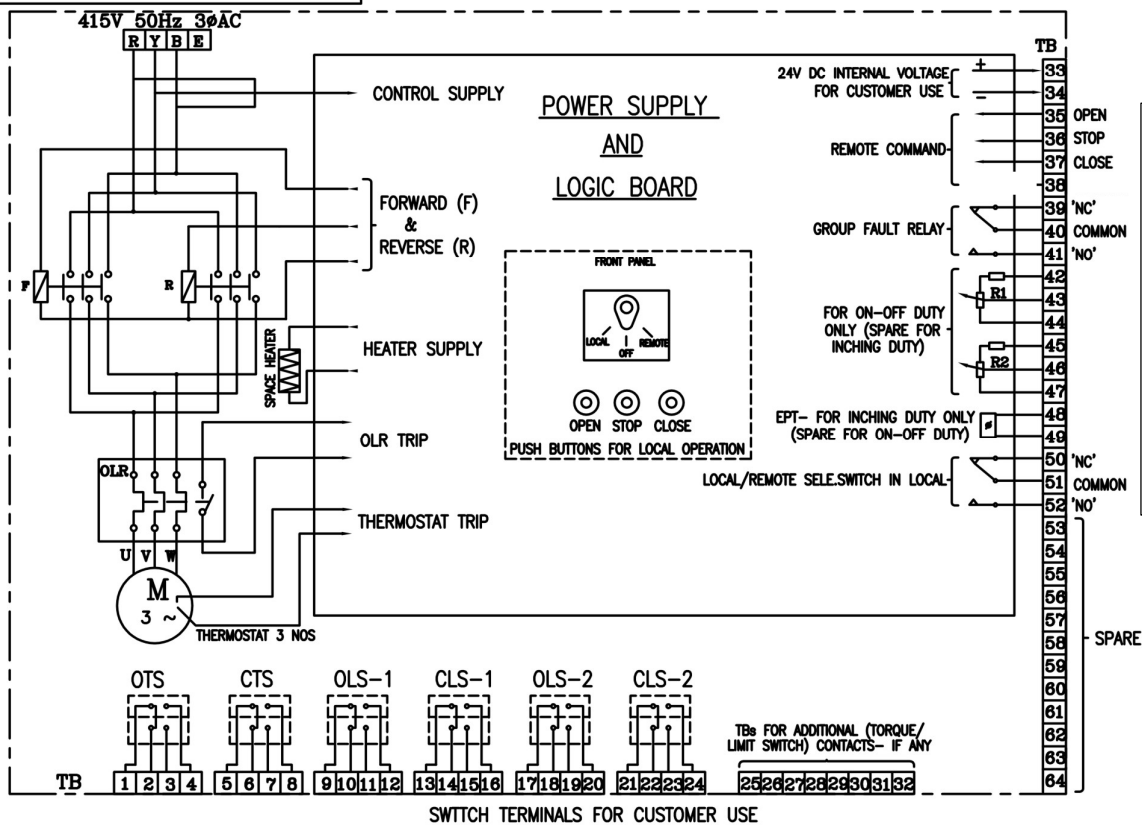

**CONTACT DEVELOPMENT DIAGRAM**

OTS	1-2	OPEN AT OVER TORQUE DURING OPENING TRAVEL
	3-4	CLOSE AT OVER TORQUE DURING OPENING TRAVEL
CTS	5-6	OPEN AT OVER TORQUE DURING CLOSING TRAVEL
	7-8	CLOSE AT OVER TORQUE DURING CLOSING TRAVEL
OLS-1	9-10	INDICATES CONTACT CLOSED
	11-12	INDICATES CONTACT OPEN
CLS-1	13-14	INDICATES CONTACT CLOSED
	15-16	INDICATES CONTACT OPEN
OLS-2	17-18	INDICATES CONTACT CLOSED
	19-20	INDICATES CONTACT OPEN
CLS-2	21-22	INDICATES CONTACT CLOSED
	23-24	INDICATES CONTACT OPEN
SWITCH	TERMINAL NO.	VALVE POSITION
	FULL OPEN	INTERMEDIATE
	FULL CLOSE	FULL CLOSE

CONTACT RATING: 5A AT 250V AC & 0.5A AT 220V DC

Separate wire (no common wire) to be used for signal exchange between DCS and actuator. Additionally, separate TBs are to be used at actuator end. Please refer attached dwg 12A05-DWG-I0021 for the same.

**SETTING PROCEDURE OF POSITION LIMIT AND TORQUE SWITCH**

VALVES	OPEN		CLOSE	
	MAIN	BACK UP	MAIN	BACK UP
GATE VALVE OF 100 mm AND ABOVE IN 1500 CL AND ABOVE RATINGS	OLS	OTS *	CLS	CTS
ALL OTHER GATE & GLOBE VALVES	OLS	OTS *	CTS	#

# - CLS NOT TO BE CONNECTED IN TRIP CIRCUIT  
\* - BYPASS OTS FOR INITIAL 5% OF TRAVEL (FOR GATE VALVES ONLY)

- NOTE:-
- ALL TORQUE AND LIMIT SWITCHES (OTS,CTS,OLS1&2, CLS1&2) ARE WITH 2NO+2NC CONTACTS '1NO+1NC' IS TERMINATED IN TBS 1-24, REMAINING CONTACTS ARE FOR INTERNAL USE. ANY SPARE CONTACTS WHICH ARE NOT USED INTERNALLY ARE TO BE TERMINATED IN TBS 25-32
  - CTS - TORQUE SWITCHES FOR CW ROTATION (CLOSE)
  - OTS - TORQUE SWITCHES FOR CCW ROTATION (OPEN)
  - OLS-1, OLS-2 - LIMITSWITCHES FOR POSITION OPEN
  - CLS-1, CLS-2 - LIMITSWITCHES FOR POSITION CLOSE
  - EPT - ELECTRONIC POSITION TRANSMITTER (POTENTIOMETRIC TYPE, FOR INCHING DUTY)
  - R1-R2-POTENTIOMETER 2 x 100 OHMS (FOR ON-OFF DUTY)
  - FOR COMMANDS & EPT EITHER INTERNALLY GENERATED 24 VDC OR EXTERNAL SUPPLY OF 24VDC CAN BE USED
  - M - MOTOR 3φ 415V 50 Hz AC SUPPLY

REV	DATE	ALTERED
		CHD & APPD

**TYPE OF PRODUCT** ELECTRICAL VALVE ACTUATORS (AC) WITH INTEGRAL STARTERS  
**OR NAME OF CUSTOMER/PROJECT** (DRAWN FOR INTERMEDIATE POSITION OF VALVES)

BHARAT HEAVY ELECTRICALS LTD., UNIT: HIGH PRESSURE BOILER PLANT. TIRUCHIRAPALLI-620014. 365-121	DRN	N.P.ESWAR	SIGN	N.P.	DATE	07.10.04	NO. OF VAR.
	CHD	D.DINAKARAN	D.D		07.10.04		
	APPD	K.ARUNACHALAM	K.A		07.10.04		

DEPT	VL	SCALE	WEIGHT (KG).	REFERENCE INFORMATIONS	NO. OF TUBES
CODE					

TITLE	CARD CODE	DRAWING NO.	REV
WIRING DIAGRAM (TERMINAL PLAN) FOR ACTUATOR WITH INTEGRAL STARTER	U 01	3-V-MISC-24227	0

CAUTION: The information on this document is the property of BHARAT HEAVY ELECTRICALS LTD. It must not be used directly or indirectly in any way detrimental to the interest of the company.





## **SECTION – III**

### **ELECTRIC MOTOR ACTUATORS**

#### **1.00.00 SCOPE**

1.01.00 This Section covers the general requirements of Electric Motor Actuators for valves, dampers and gates.

1.02.00 All electric motor actuators shall be furnished in accordance with this general specification and the accompanying driven equipment specification.

#### **2.00.00 CODES & STANDARDS**

2.01.00 All equipment and materials shall be designed, manufactured and tested in accordance with the latest applicable Indian standards (IS), IEC, ANSI & NEMA. Standards except when otherwise stated herein or in the driven equipment specification.

2.02.00 Equipment and material conforming to any other standard, which ensures equal or better quality, may be accepted. In such case the seller shall provide details of how his standards comply with the Buyer's requirement and duly certified copies of the English version of the standard adopted shall be submitted.

#### **3.00.00 SERVICE CONDITIONS**

3.01.00 The actuator shall be suitable for operation in hot, humid and tropical atmosphere, highly polluted at places with coal dust and/or fly ash.

3.02.00 Unless otherwise noted, electrical equipment/system design shall be based on the service conditions and auxiliary power supply given in the annexure to this specification.

#### **4.00.00 RATING**

4.01.00 For isolating service, the actuator shall be rated for three successive open-close operation of the valve/damper or minimum S2-15 minutes as per IEC-60034-1, whichever is longer.

4.02.00 For regulating service, the actuator shall be suitably time rated for the duty cycle involved with necessary number of starts per hour, but in no case less than 150 starts per hour.

#### **5.00.00 PERFORMANCE**

The actuator shall meet the following performance requirements:

5.01.00 Open and close the valve completely and make leak-tight valve closure without jamming.

5.02.00 Attain full speed operations before valve load is encountered and impart an unseating blow to start the valve in motion (hammer blow effect).





- 5.03.00 Operate the valve stem at standard stem speed and shall function against design differential pressure across the valve seat.
- 5.04.00 The motor reduction gearing shall be sufficient to lock the shaft when the motor is de-energised and prevent drift from torque switch spring pressure.
- 5.05.00 The entire mechanism shall withstand shock resulting from closing with improper setting of limit switches or from lodging of foreign matter under the valve seat.
- 6.00.00 **SPECIFIC REQUIREMENT**
- 6.01.00 **Construction**
- 6.01.01 The actuator shall essentially comprise the drive motor, torque & limit switches, gear train, self locking features, clutch, hand wheel, position indicator & transmitter, in-built thermostat for over load protection, space heater and internal wiring.
- 6.01.02 The actuator enclosure shall be totally enclosed, dust tight, weather-proof suitable for outdoor use without necessity of any canopy.
- 6.01.03 All electrical equipment, accessories and wiring shall be provided with tropical finish to prevent fungus growth.
- 6.01.04 The actuator shall be designed for mounting in any position without any lubricant leakage or operating difficulty.
- 6.01.05 All motorized actuators shall be Smart Type and shall be furnished with Integral Starter mounted on the actuator and compatible with DCS/PLC. The Integral Starter shall be complete with:
1. One (1) triple pole breaker
  2. One (1) no. reversing starter with mechanically interlocked contactors, 3 thermal overload relays, 2 NO + 2 NC aux. contacts for each contactor.
  3. One (1) no. Remote- Local selector switch
  4. CLOSE-STOP-OPEN oil tight push buttons with indication lights. STOP push button shall be latchable type.
  5. 415 / 240 V control transformer with primary and secondary fuses.
- These actuators shall have diagnostic feature with valve checking facility from remote.
- 6.02.00 **Motor**
- 6.02.01 The drive motor shall be three phase, squirrel cage, induction machine with minimum class F insulation and weatherproof IPW-55 enclosure, designed for high torque and reversing service.



6.02.02 The motor shall be designed for full voltage direct on-line start, with starting current limited to 6 times full-load current.

6.02.03 The motor shall be capable of starting at 85 percent of rated voltage and running at 80 percent of rated voltage at rated torque and 85 percent rated voltage at 33 percent excess rated torque for a period of 5 minutes each.

6.02.04 Earthing terminals shall be provided on either side of the motor.

#### 6.03.00 **Limit Switches**

Each actuator shall be provided with following limit switches: -

6.03.01 2 torque limit switches, one for each direction of travel, self-locking, adjustable torque type.

6.03.02 4 end-of-travel limit switches, two for each direction of travel.

6.03.03 Open / Close command termination logic with position and torque limit switch positioner circuitry shall be suitably built in a PCB inside the actuator.

- a) For binary drive, open/close/stop command and status thereof and disturbance monitoring signal (common contact for overload, thermostat, control supply failure, L/R selector switch at local, other protections operated) shall be provided.

Interface with the control system shall be through hardwired signal only. Interposing relays provided (with coil burden 2.5 VA) in the actuator shall be energized to initiate opening and closing, by 24V DC signal from the external control system.

- b) For modulating drive, the command to actuator shall be in form of 4-20mA signal. The necessary positioning circuit and motor protection shall be provided

- c) Open/close command termination logic shall be suitably built inside actuator.

6.03.04 2 position limit switches, one for each direction of travel, each adjustable at any position from fully open to fully closed positions of the valve/damper.

6.03.05 Each limit switch shall have 2 NO + 2 NC potential free contacts. Contact rating shall be 5A at 240V A.C. or 0.5A at 220V D.C.

#### 6.04.00 **Hand Wheel**

Each actuator shall be provided with a hand wheel for emergency manual operation. The hand wheel shall declutch automatically when the motor is energized.

#### 6.05.00 **Position Indicator/Transmitter (applicable for inching services only)**

The actuator shall have:

6.05.01 One (1) built-in local position indicator for 0-100% travel.





6.05.02 One (1) no. transducer (4-20 ma) for remote position indicator for 0-100 % travel

6.06.00 **Space Heater**

A space heater shall be included in the limit switch compartment suitable for 240V, 1 phase, 50 Hz supply.

6.07.00 **Wiring**

All electrical devices shall be wired up to and terminated in a terminal box. The internal wiring shall be of sufficient size for the power rating involved but in no case less than 1.5 Sq.mm copper. All wiring shall be identified at both ends with ferrules.

6.08.00 **Terminal Box**

The terminal box shall be weather proof, with removable front cover and cable glands for cable connection. The terminal shall be suitable for connection of 2X2.5 Sq.mm copper conductors.

7.00.00 **TEST**

The actuator and all components thereof shall be subject to tests as per relevant Standards. In addition, if any special test is called for in equipment specification, the same shall be performed.





**C&I SPECIFICATION FOR  
CONDENSATE POLISHING UNIT**

SECTION: C  
SUB SECTION: C&I

**FIELD & MEASURING INSTRUMENTS**

**WBPDC**

**EPC Bid Document**  
**Sagardighi Thermal Power Project**  
**1x660 MW Unit No. 5, Phase - III**

## **SECTION-VI**

### **TECHNICAL SPECIFICATION**

#### **CONTROL AND INSTRUMENTATION SYSTEMS**

##### **1.00.00 FIELD INSTRUMENTS**

This section provides general guidelines for field instruments and equipment to be supplied under this specification. All measuring instruments/equipment and subsystems offered by Bidder shall be from reputed experienced manufacturer of specified type and range of equipment, whose guaranteed and trouble free operation has been established. All instruments/equipment shall be of proven reliability, accuracy, repeatability requiring a minimum of maintenance and comply with the acceptable international standards. All instruments/equipment and accessories shall be supplied as per technical specifications, ranges, make as approved by Owner.

- i) HART management system shall be integral feature of the DDCMIS and shall be provided for centralised configuration, maintenance, diagnostics & record-keeping for all electronic transmitters.
- ii) Bidder shall provide following facilities as a minimum through software:
  - a) Constant scanning to monitor faults of changes to instrument configuration.
  - b) Owner-defined and standard calibration and configuration procedures for all transmitters.
  - c) Constant signal data collection facilities to maintain continuously updated records.
  - d) Automatic tracking of configuration changes made in the field, such as may be introduced by hand-held communicator. All configuration function associated with hand-held communicators shall be available in the system.
  - e) Event and log reports on screen as well as on printer.
  - f) Any addition/deletion of transmitter will be reported on printer and logged in hard disk.

##### **1.01.00 PRESSURE TRANSMITTER**

01. Type : Microprocessor based Smart, HART protocol compatible
02. Transmission : 2 - Wire



**WBPDC**

**EPC Bid Document**  
**Sagardighi Thermal Power Project**  
**1x660 MW Unit No. 5, Phase - III**

- |      |                     |   |   |
|------|---------------------|---|---|
| 03.  | Output Signal       | : | Simultaneous transmission of digital and 4-20 mA DC signal.   |
| 04.  | Signal Processing   | : | Silicon solid state electronic circuitry  |
| 05.  | Sensor type         | : | Capsule / Diaphragm   |
| 06.  | Element material    | : | AISI-316 or better  |
| 07.  | Static Pressure     | : | 150 % of maximum span continuously, without affecting the calibration.  |
| 08.  | Turn-down ratio     | : | 10 : 1 for vacuum/very low pressure application ; 30 : 1 minimum for other applications.  |
| 09.  | Span and Zero       | : | Locally adjustable non-interacting. Facility for elevation and suppression by 100% of span  |
| 10.  | Enclosure Class     | : | Weather proof as per IP-65 with durable corrosion resistant epoxy coating (Explosion proof for NEC Class-1, Division 1 area wherever required)  |
| 11.  | Output Indicator    | : | Backlit LCD type  |
| 12.  | Nameplate           | : | Tag number, service engraved in stainless steel tag plate   |
| 13.  | Body                | : | Forged Carbon Steel (SS for DM Water & corrosive service).  |
| 14.  | Power supply        | : | 16 - 48 Volts D.C.  |
| 15.  | Load                | : | 500 Ohms (min.) at 24 Volts D.C.  |
| 16.  | Ambient Temperature | : | 0 - 50°C  |
| 17.  | Performance :       |   |   |
| i)   | Accuracy            | : | $\pm 0.075\%$ of Span or better   |
| ii)  | Repeatability       | : | $\pm 0.05\%$ of Span or better  |
| iii) | Response time       | : | 100 msec or better  |
| iv)  | Stability           | : | $\pm 0.1\%$ of Calibrated Span for 6 months up to 70 Kg/cm <sup>2</sup> and $\pm 0.25\%$ of Calibrated Span for more than 70 Kg/cm <sup>2</sup> |
| v)   | Zero and span drift | : | $\pm 0.015\%$ per deg. C at max span and 0.11% per deg. C at min span   |
| 18.  | Sealing/Isolation   | : | Extended diaphragm with 5 meters SS armored capillary for corrosive, viscous and dirty fluid applications. Material for separator               |



**WBPDCCL**

**EPC Bid Document**  
**Sagardighi Thermal Power Project**  
**1x660 MW Unit No. 5, Phase - III**

diaphragm shall be as per application. Where the process fluids are corrosive, viscous, solid bearing or slurry type, diaphragm seals shall be provided. Parts below the diaphragm shall be removable for cleaning. The entire volume above the diaphragm shall be completely filled with an inert liquid suitable for the application

- |     |             |   |  |
|-----|-------------|---|--|
| 19. | Diagnostics | : | Self indicating feature  |
| 20. | Accessories | : | <ul style="list-style-type: none"> <li>a) Universal mounting bracket suitable for 2" pipe mounting.</li> <li>b) High tensile carbon steel U- bolts.</li> <li>c) Installation accessories as per relevant installation drawing.</li> <li>d) Syphons for steam and hot water services.</li> <li>e) ½" NPT 2-valve stainless steel manifold for pressure transmitters constructed from SS316 bar stock. In case it becomes necessary to use a DP transmitter for gauge pressure measurement then a 2-valve manifold should be used in place of 5-valve manifold.</li> <li>f) Companion flange with nuts, bolts and gaskets.</li> <li>g) Hand held configurator kit for calibration of Smart Transmitter.</li> </ul> |

#### 1.02.00 Differential Pressure Transmitter

- |     |                        |   |   |
|-----|------------------------|---|---|
| 01. | Type                   | : | Microprocessor based Smart, HART protocol compatible        |
| 02. | Transmission           | : | 2-Wire  |
| 03. | Output signal          | : | Simultaneous transmission of digital and 4-20 mA DC signal. |
| 04. | Signal Processing Unit | : | Silicon solid-state electronic circuitry                    |
| 05. | Sensor type            | : | Capsule/Diaphragm   |
| 06. | Element material       | : | AISI-316 (Stainless Steel) or better                        |
| 07. | Static Pressure/       |   |   |



**WBPDC**

**EPC Bid Document**  
**Sagardighi Thermal Power Project**  
**1x660 MW Unit No. 5, Phase - III**

- Overload Pressure : Maximum line (or static) pressure on either side without permanent deformation or loss of accuracy
08. Turn-down ratio : 10 :1for vacuum/very low pressure application; 30 : 1 minimum for other applications.
09. Span and Zero : Locally adjustable, non-interacting
10. Enclosure class : Weather proof as per IP-65 with durable corrosion resistant epoxy coating (Explosion proof for NEC Class-1, Division 1 area wherever required))
11. Zero suppression / elevation : At least 100% of Span
12. Output Indicator : Backlit LCD type
13. Nameplate : Tag number and Service engraved in stainless steel tag plate
14. Body : Forged Carbon Steel (SS for DM Water)
15. Ambient temperature : 0 - 50<sup>o</sup> C
16. Power supply : 16 - 48 Volts DC
17. Load : 500 Ohms (min.) at 24 Volts DC
18. Performance :-
- i) Accuracy :  $\pm 0.2$  % of span or better
  - ii) Repeatability :  $\pm 0.05$  % of span or better
  - iii) Response time : 100 msec or better
  - iv) Stability :  $\pm 0.1\%$  of Calibrated Span for 6 months up to 70 Kg/cm<sup>2</sup>
  - v) Zero and span drift :  $\pm 0.015\%$  per deg. C at max span and 0.11% per deg. C at min span
19. Sealing/Isolation : Extended diaphragm with 5 meters. SS armored capillary for corrosive, viscous and dirty fluid applications. Material for separator diaphragm, depending on application.
20. Diagnostics : Self indicating feature
21. Accessories : a) Universal mounting bracket suitable for 2" pipe mounting.



**WBPDCCL**

**EPC Bid Document**  
**Sagardighi Thermal Power Project**  
**1x660 MW Unit No. 5, Phase - III**

- b) High tensile carbon steel U-bolts.
- c) Installation accessories as per relevant installation drawing.
- d) Syphons for steam and hot water services.
- e) ½” NPT 5-valve stainless steel manifold, constructed from SS316 bar stock.
- f) Companion flange with nuts, bolts and gaskets.
- g) Hand held configurator kit for calibration of Smart Transmitter.

#### 1.02.00 DISPLACER TYPE LEVEL TRANSMITTERS

- |     |                                      |   |   |
|-----|--------------------------------------|---|---|
| 01. | Type                                 | : | SMART   |
| 02. | Stages of operation                  | : | Continuous  |
| 03. | Material -                           |   |   |
|     | i) Displacer                         | : | AISI 316 SS   |
|     | ii) Suspension wire                  | : | AISI 316 SS   |
|     | iii) Torque tube housing application | : | Carbon steel or SS as per application   |
|     | iv) Torque tube                      | : | Inconel   |
|     | v) Displacer chamber                 | : | Carbon steel or SS as per process application                                       |
|     | vi) Transmitter Housing              | : | Die cast aluminium or better  |
| 04. | Power supply                         | : | 16-48 Volts D.C.  |
| 05. | Transmission                         | : | 2-wire  |
| 06. | Output Signal                        | : | Simultaneous transmission of digital and 4-20 mA DC signal. Standard HART protocol. |
| 07. | Signal processing                    | : | Solid-state electronic circuitry  |
| 08. | Static / overload pressure           | : | Maximum static pressure without permanent deformation or loss of accuracy.          |
| 09. | Turn-down ratio                      | : | 10 : 1 or better  |



**WBPDC**

**EPC Bid Document**  
**Sagardighi Thermal Power Project**  
**1x660 MW Unit No. 5, Phase - III**

10. Zero & Span : Easily accessible (local zero & span adjustment and non-interactive type)
11. Enclosure Class : IP-65 (Explosion proof for NEC Class-1, Division 1 area)
12. Output Indicator : Yes, Backlit LCD type
13. Nameplate : Tag number and Service engraved in stainless steel tag plate
14. Ambient Temperature : 0 - 50°C
15. Load Impedance : 500 Ohms at 24 Volts (minimum)
16. Process Connection : 2" Companion flange with nuts, bolts and gaskets
17. Performance -
  - Accuracy :  $\pm 0.2\%$  of span or better
18. Accessories :
  - a) Counter Flange, nuts, bolts, gaskets etc.
  - b) Weights for 5 point calibration of instruments.
  - c) Vent and drain plugs
  - d) Special calibration tool/configurator, if any.
19. Preferred Features :
  - a) Test plug connection and cutout terminals physically separated from other electronics.
  - b) Electronic Damping facility (adjustable).

### 1.03.00 ~~MASS FLOW METER~~

- A. Sensor
  01. Measuring Principle : Coriolis Mass flow.
  02. Primary Element : Flow Tube of 316SS or better
  03. Temperature Control : To be provided for heavy fuel oil application. Heating arrangement shall be integral. For Heating
  04. Process Connection : Flanged and rating as per process requirement.
  05. Drain : Self-draining facility



**WBPDC**

**EPC Bid Document**  
**Sagardighi Thermal Power Project**  
**1x660 MW Unit No. 5, Phase - III**

06. Enclosure : Stainless steel
07. Accessories : Counter flanges, Mounting nuts, bolts, gaskets etc.
- B. Transmitter
01. Measured quantities : Mass Flow rate, Total Mass Flow, Density, Temperature as minimum.
02. Input Signal Processing : Digital Processing.
03. Display : Digital Display (LCD).
04. Output : 2 Nos. isolated output of 4-20mA DC with HART protocol, selectable from four measured quantities & field bus output for softlink with DCS
05. Load : < 750 ohms.
06. Power supply : "UPS", (if the external power supply is 230V AC, 50 HZ).
07. Turn Down : 100:1
08. Accuracy :  $\pm 0.2\%$  of measured value
09. Housing : IP 65 (Explosion proof for NEC Class-1, Division 1 area).
10. Hazardous duty Version : FM Standards.
11. Nameplate : Tag number, service engraved in stainless steel tag plate
12. Accessories : a) As required for field mounting  
 b) Handheld configurator  
 c) Mounting U-bolts, nuts, bolts, prfab cable etc.

#### 1.04.00 Turbine Flow meter

##### A. Sensor

01. Type : Turbine (in line full-bore, based on magnetic pick up pulses)



**WBPDC**

**EPC Bid Document**  
**Sagardighi Thermal Power Project**  
**1x660 MW Unit No. 5, Phase - III**

02. Output Signal : Pulse
03. Material of Construction : a) Body : AISI 316  
 b) Rotor: AISI 431 or 410  
 c) Bearings: Tungsten Carbide / Stellite Sleeve
04. Flow rate range : As required.
05. Linearity :  $\pm 0.25\%$  or better.
06. Repeatability :  $\pm 0.02\%$  or better.
07. Ambient temperature :  $50^{\circ}\text{C}$
08. Mounting : On-Line, flanged
09. Enclosure : IP 65
- B. Transmitter
01. Electronics : Solid State
02. Power Supply : "UPS", if the external power supply is 230V AC, 50 HZ.
03. Input : Input from Sensor
04. Display : Backlit LCD
05. Output : Isolated 4-20mA DC with HART protocol.
06. Measuring Accuracy :  $\pm 0.5\%$  of full scale range
07. Totalized Value : Required
08. Housing : IP-65 (Explosion proof for NEC Class-1, Division 1 area)
09. Nameplate : Tag number, service engraved in stainless steel tag plate
10. Accessories : a) Clamping strip, bracket, prefab cable etc.  
 b) Calibration or cofigurator kit.

1.05.00 Vortex Flow meter

A. Sensor

01. Type : Vortex



Development Consultants Pvt. Ltd.

Page 8 of 169

**Volume : II-E**  
**Section : VI**  
**Control & Instrumentation**  
**Systems**

**WBPDC**

**EPC Bid Document**  
**Sagardighi Thermal Power Project**  
**1x660 MW Unit No. 5, Phase - III**

- |                       |                          |   |   |
|-----------------------|--------------------------|---|---|
| 02.                   | Output Signal            | : | Pulse   |
| 03.                   | Material of Construction | : | AISI 316  |
| 04.                   | Sensor Seal              | : | PTFE / higher based on temperature  |
| 05.                   | Flow range               | : | As required.  |
| 06.                   | Linearity                | : | $\pm 1\%$ or better.  |
| 07.                   | Repeatability            | : | $\pm 0.2\%$ or better.  |
| 08.                   | Ambient temperature      | : | 50°C  |
| 09.                   | Mounting                 | : | On-Line, flanged.   |
| 10.                   | Enclosure                | : | IP 65   |
| 11.                   | Accessories              | : | Nuts, bolts, gaskets etc.   |
| <b>B. Transmitter</b> |                          |   |   |
| 01.                   | Electronics              | : | Solid State-remote mounting   |
| 02.                   | Power Supply             | : | 24 V DC.  |
| 03.                   | Input                    | : | Input from Sensor   |
| 04.                   | Display                  | : | Backlit LCD   |
| 05.                   | Output                   | : | Isolated 4-20mA DC.   |
| 06.                   | Protocol                 | : | HART  |
| 07.                   | Totalized Value          | : | Required  |
| 08.                   | Housing                  | : | IP-65 (Explosion proof for NEC Class-1, Division 1 area)  |
| 09.                   | Nameplate                | : | Tag number, service engraved in stainless steel tag plate   |
| 10.                   | Accessories              | : | a) Clamping strip, bracket, prefab cable etc.<br>b) Special tool kit for calibration/ configuration . |



**WBPDC**

**EPC Bid Document**  
**Sagardighi Thermal Power Project**  
**1x660 MW Unit No. 5, Phase - III**

1.06.00

## Rotameter

- |     |                          |   |  |
|-----|--------------------------|---|--|
| 01. | Type                     | : | Online upto 2" and Bypass above 2" line size"  |
| 02. | Metering tube            | : | Borosilicate glass   |
| 03. | Float                    | : | AISI 316-SS unless the process fluid demands some other material.  |
| 04. | Body MOC                 | : | SS as per fluid condition.   |
| 05. | Scale                    | : | Aluminium Graduated - Engraved black on white background.  |
| 06. | Process connection       | : | Flanged to line size or threaded for connection size ½" or less.   |
| 07. | Accuracy                 | : | ± 2% of full scale detection or better for on-line type and ±4% of full-scale detection or better for by-pass type.                                    |
| 08. | Nameplate                | : | Tag number, service engraved in stainless steel tag plate  |
| 09. | Accessories              | : | Slip-on orifice plate of 316-SS and taps of / SS as per application. Applicable SS Isolation valves and SS Range Orifice - for bypass type rotameters. |
| 10. | Housing protection class | : | IP- 65.  |

1.07.00

## Pressure Gauge and Differential Pressure Gauge

- |     |                      |   |                           |
|-----|----------------------|---|---------------------------|
| 01. | Type                 | : | Bourdon/Bellows/Diaphragm |
| 02. | MOC Sensing & Socket | : | AISI-316 SS               |
| 03. | Movement Material    | : | AISI-304 SS               |
| 04. | Case Material        | : | Stainless steel..         |
| 05. | Bezel Material       | : | SS 304.                   |
| 06. | Socket Material      | : | SS 316                    |
| 07. | Enclosure            | : | IP-65.                    |
| 08. | Dial Size            | : | 150 mm                    |



**WBPDC**

**EPC Bid Document**  
**Sagardighi Thermal Power Project**  
**1x660 MW Unit No. 5, Phase - III**

- |     |                               |   |   |
|-----|-------------------------------|---|---|
| 09. | Scale                         | : | Black lettering on white background in 270 Deg. arc.  |
| 10. | Window                        | : | Shatterproof glass  |
| 11. | Range Selection               | : | Normal process pressure – 50 ~ 70 % of range (approximately).   |
| 12. | Over-range Protection         | : | 125% of maximum range by internal stop. External stop at zero   |
| 13. | Adjustment                    | : | Micrometer screw for zero adjustment. Internal micrometer screw for range adjustment.<br><br>External zero adjustment for glycerine filled gauges.  |
| 14. | Element Connection            | : | Argon welding   |
| 15. | Process Connection            | : | 1/2" NPT(M) Bottom connection for local mounting, back connection for panel mounting.   |
| 16. | Performance                   | : | Accuracy of $\pm 1.0$ % of span or better.  |
| 17. | Operating ambient temperature | : | 0 - 50°C  |
| 18. | Safety Feature                | : | Blow out disc./diaphragm at the back  |
| 19. | Accessories                   | : | <ul style="list-style-type: none"> <li>a) Snubbers and Glycerin filled for pulsating fluid applications and at pump discharge.</li> <li>b) Stainless steel Diaphragm chemical seals for corrosive, viscous and solid-bearing or slurry type process fluids. diaphragm chemical seal shall be provided with the following: <ul style="list-style-type: none"> <li>1) Top chamber : SS 304</li> <li>2) Bottom Chamber: SS 316</li> <li>3) Sealing fluid: Silicon DC 200</li> <li>4) Diaphragm: SS 316</li> </ul> </li> <li>c) 3-way SS gauge cock/ 2-Valve SS-316 barstock manifold for pressure gauges with 1/2" NPT process connection..</li> </ul> |



**WBPDC**

**EPC Bid Document**  
**Sagardighi Thermal Power Project**  
**1x660 MW Unit No. 5, Phase - III**

- d) 5-valve SS316 manifold constructed from barstock for differential pressure gauge. Process connection ½" NPT.
- e) Union, nut & tail piece and other Installation accessories as required.
- f) Syphons for steam and hot water services.

- 20. Applicable standard : IS-3624 / 1996 , EN-837-1
- 21. Nameplate : Tag number, service engraved in stainless steel tag plate

#### 1.08.00 Temperature Gauge

- 01. Type : Inert gas filled remote mounting system.
- 02. Sensing Element Material : Bourdon - AISI-316 SS
- 03. Capillary Armoring : Stainless steel flexible
- 04. Movement Material : AISI 304 SS
- 05. Bulb / Stem Diameter : 12 mm
- 06. Bulb / Stem Material : AISI 316
- 07. Capillary : Stainless Steel
- 08. Thermometer connection to well : ½" NPT
- 09. Case Material : Stainless steel
- 10. Dial Size : 150 mm in general (100 mm for SWAS gauges)
- 11. Scale : Black lettering on white background in 270 Deg. arc.
- 12. Mounting : Surface/Panel
- 13. Over range Protection : 125 % of range or more
- 14. Instrument connection : Bottom connection for local mounting and back connection for panel mounting.



**WBPDC**

**EPC Bid Document**  
**Sagardighi Thermal Power Project**  
**1x660 MW Unit No. 5, Phase - III**

- |     |                 |   |   |
|-----|-----------------|---|---|
| 15. | Range           | : | Normal temperature – 50 ~ 70% of range approximately.   |
| 16. | Zero adjuster   | : | Micrometer screw adjustable from front.   |
| 17. | Window          | : | Shatterproof glass.   |
| 18. | Accuracy        | : | $\pm 1\%$ or better   |
| 19. | Enclosure Class | : | IP-65   |
| 20. | Capillary       | : | 5 meters (local)/15.0 meters (local panel) - armoured stainless steel   |
| 21. | Compensation    | : | Capillary and Case Compensation   |
| 22. | Accessories     | : | a) Forged/barstock SS316 thermowell screwed as per ASME PTC code. Process connection M 33X2 (M). Material of construction of thermowell:<br>1) SS 316: in general<br>2) Inconel: For flue gas application<br>3) Tungsten carbide: For coal mill application<br><br>b) Installation accessories as required. |
| 23. | Nameplate       | : | Tag number, service engraved in stainless steel tag plate   |

1.09.00

## Thermocouples

- |      |                    |   |  |
|------|--------------------|---|--|
| 01.  | Type               | : | a) Type-K (Chromel Alumel) / Type-R (Pt.-Rhodium Pt.) / Type-E (Chromel Constantan) [As per application]<br><br>b) Duplex (Triplex incase of turbine/Generator/excitor bearing temperature may be used)<br><br>c) Ungrounded |
| 02.  | Wire gauge         | : | 16 AWG for Type-K, 24 AWG for Type-R   |
| 03.  | Standard           | : | ANSI-MC 96.1.  |
| 04.  | Protecting Tube :- |   |  |
| i)   | O.D.               | : | 8 mm   |
| ii)  | Material           | : | 316-SS Seamless  |
| iii) | Filling            | : | Magnesium Oxide (Purity above 99.4%)   |



**WBPDC**

**EPC Bid Document**  
**Sagardighi Thermal Power Project**  
**1x660 MW Unit No. 5, Phase - III**

05. Response time with Thermowell : a) Less than 20 seconds for measurement.  
 b) Less than 10 seconds for control.
06. Accuracy :  $\pm 1.1^{\circ}\text{C}$  upto  $300^{\circ}\text{C}$  & 0.4% of measured temperature range above  $300^{\circ}\text{C}$ .
07. Head :
- i) Type : IP-65 universal screwed type. (Explosion proof for NEC Class-1, Division 1 area)
  - ii) Material : Die cast aluminum or better
  - iii) Terminal blocks : Nickel plated Brass - screw type / silver plated
  - iv) Instrument connection :  $\frac{1}{2}$ " NPT to well
  - iv) Cable connection :  $\frac{1}{2}$ " NPT gland and grommet.
  - v) Others : Terminal head cover with SS chain and suitable gasket. All thermowells in the high velocity steam service shall be checked for Strouhal's frequency limit to arrive at a safe size and design of thermowells"
08. Accessories : a) Adjustable nipple-union-nipple [ $\frac{1}{2}$ " Sch 80 X  $\frac{1}{2}$ " NPT (M)] with thermowell connection  
 b) Compression fittings/unions  
 c) Flanges etc. (for flanged connections only)  
 d) Barstock thermowell of stepless tapered design as per ASME PTC19.3 code.
- Process connection M33x2 (M) in general or  $1\frac{1}{2}$ " flanged for flue gas/Furnace/air etc. application.
- Material of construction of thermowell:
- 1) SS 316: in general
  - 2) Inconel: For flue gas application
  - 3) Tungsten carbide: For coal mill application.



**WBPDCCL**

**EPC Bid Document**  
**Sagardighi Thermal Power Project**  
**1x660 MW Unit No. 5, Phase - III**

09. Nameplate : Tag number, service engraved in stainless steel tag plate

1.10.00

Passing condition of various drain valves shall be monitored by measuring drain pipe metal temperature at the downstream of the drain valves. Also Drum, SH, RH metal temperature measurement shall be provided. Necessary thermocouples shall be provided as per the following specification.

- |     |                                       |   |   |
|-----|---------------------------------------|---|---|
| 01. | Measuring medium                      | : | Metal temperature   |
| 02. | Metal of thermocouple element         | : | Chromel-Alumel Type-K   |
| 03. | Type of thermocouple ungrounded type. | : | Duplex with separate hot junctions,   |
| 04. | Insulation                            | : | Mineral insulation Magnesium Oxide  |
| 05. | Thermocouple wirer gauge              | : | 16 AWG  |
| 06. | Protective Sheath                     | : | SS 321  |
| 07. | Protective Sheath Dia                 | : | 8 mm O.D.   |
| 08. | Characteristics of thermocouple       | : | Special limits of error as in ANSI MC 96.01.1975  |
| 09. | Mounting Accessories                  | : | 1/2" BSP SS sliding end connector, weld pad, weld on clamps of heat resistant steel SS 310.               |
| 10. | Cold end sealing                      | : | SS pot seal with colour coded PTFE headed sleeve insulated flexible tails. Sealing compound - Epoxy resin |
| 11. | Minimum Bending Radius                | : | 30 mm   |
| 12. | Length of T/C                         | : | 30 mtrs. (minimum)  |

1.11.00

Resistance Temperature Detector

- |     |            |   |                                   |
|-----|------------|---|-----------------------------------|
| 01. | Type       | : | Platinum (Duplex), Ungrounded     |
| 02. | Resistance | : | 100 ohm at 0°C                    |
| 03. | Base       | : | Wound on ceramic (anti-inductive) |
| 04. | Wiring     | : | 3 /4 Wire                         |



**WBPDCCL**

**EPC Bid Document**  
**Sagardighi Thermal Power Project**  
**1x660 MW Unit No. 5, Phase - III**

05. Protecting Tube :-
- i) O.D. : 8 mm
  - ii) Material : SS-316, Seamless
  - iii) Filling : Magnesium oxide (Purity above 99.4%).
06. Response time : a) < 20 seconds for measurement.  
b) < 10 seconds for control.
07. Calibration : DIN 43760
08. Accuracy :  $\pm 0.5\%$  of range
09. Head :
- i) Type : IP-65 universal screwed type. (Explosion proof for NEC Class-1, Division 1 area)
  - ii) Material : Die cast aluminum or better
  - iii) Terminal blocks : Nickel plated Brass-screw type / silver plated
  - iv) Cable connection :  $\frac{1}{2}$ " NPT gland and grommet.
  - v) Others : Terminal head cover with SS chain and suitable gasket. All thermowells in the high velocity steam service shall be checked for Strouhal's frequency limit to arrive at a safe size and design of thermowells"
10. Accessories : a) Adjustable nipple-union-nipple [ $\frac{1}{2}$ " Sch 80 X  $\frac{1}{2}$ " NPT (M)] with thermowell connection
- b) Compression fittings/unions
  - c) Flanges etc. (for flanged connections only)
  - d) Barstock thermowell of stepless tapered design as per ASME PTC19.3 code.
- Process connection M33x2 (M) in general or 1 $\frac{1}{2}$ " flanged for flue gas/Furnace/air etc. application.
- Material of construction of thermowell:
- 1) SS 316: in general
  - 2) Inconel: For flue gas application



**WBPDCCL**

**EPC Bid Document**  
**Sagardighi Thermal Power Project**  
**1x660 MW Unit No. 5, Phase - III**

3) Tungsten carbide: For coal mill application.

11. Nameplate : Tag number, service engraved in stainless steel tag plate

#### 1.12.00 Pressure Switch

01. Type : i) Piston for high pressure application (above 40 bar)

ii) Bellow /Diaphragm for low pressure application (below 40 bar)

02. Sensing element material : AISI SS-316. All other wetted part SS316.

03. Case Material : Die-cast aluminum alloy with neoprene gasket.

04. Setter Scale : Black graduation on white linear scale. Graduation 0-100% with red pointer for set points.

05. Over range : 150 % of maximum pressure

06. Adjustments : a) Internal Set Point  
b) Differential adjustment

07. End Connection : 1/2" NPT (M) bottom connected

08. Switch configuration : Two SPDT

09. Switch Rating : 240V, 5A AC/220V, 0.5A DC

10. Switch Type : Snap acting, shock & vibration proof

11. Terminal Block : Suitable for full ring lugs for cable connection.

12. Elect connection : Plug in socket

13. Enclosure Class : IP-65 weather and dust proof (Explosion proof for NEC Class-1, Division 1 area).

14. Performance : a) Repeatability  $\pm 0.5\%$  of full range  
b) Accuracy of Setting Indication of  $\pm 1.5\%$

15. Ambient temperature : 0 – 50°C



**WBPDC**

**EPC Bid Document**  
**Sagardighi Thermal Power Project**  
**1x660 MW Unit No. 5, Phase - III**

16. Nameplate : Tag number, service engraved in stainless steel tag plate
17. Accessories : a) Remote diaphragm seal with SS-316 capillary for viscous & corrosive application. MOC of seal material shall be as per process fluid requirement.
- b) Snubbers for pulsating fluid application.
- c) Syphons for steam and hot water services.
- d) Retention ring and screws for surface mounting.
- e) 1/2" NPT 2 Valve SS-316 manifold constructed from barstock
- f) Brass cable gland

#### 1.13.00 Differential Pressure Switch

01. Type : Bellows / Diaphragm / Piston actuated
02. Sensing element material : AISI SS-316. For all other wetted part SS 316
03. Case Material : Die-cast aluminum alloy with neoprene gasket.
04. Setter Scale : Black graduation on white scale with 0-100% graduation and provided with red pointer for set point adjustment
05. Over range : Static pressure on any one side, the other side being open to atmosphere.
06. Adjustments : a) Internal set point adjustment  
b) Differential adjustment
07. Process Connection : 1/2" NPT (M) bottom connected / back connected.
08. Switch configuration : Two SPDT
09. Switch rating : 240V, 5A AC/220V, 0.5A DC.
10. Switch type : Snap acting type contacts, shock and vibration proof.



**WBPDC**

**EPC Bid Document**  
**Sagardighi Thermal Power Project**  
**1x660 MW Unit No. 5, Phase - III**

11. Terminal Blocks : Suitable for full ring lugs for cable connection.
12. Elect connection : Plug in socket
13. Performance : a) Repeatability  $\pm 0.5\%$  of full range  
b) Accuracy of set point Indication:  $\pm 1.5\%$
14. Operating Ambient Temperature : 0 - 50°C
15. Enclosure : IP-65 (Explosion proof for NEC Class-1, Division 1 area).
16. Accessories : a) Snubbers for pulsating fluid application.  
b) Syphons for steam and hot water services.  
c) Retention ring and screws for surface mounting.  
d) 1/2" NPT 3-Valve SS-316 manifold constructed from barstock
17. Nameplate : Tag number, service engraved in stainless steel tag plate
18. Remote Seal type for special application : a) Silicone oil / fluorolube filled remote diaphragm seal for dirty / viscous / corrosive fluid.  
b) SS armoured capillary at least 3 meters each.  
c) Adapter flanges with nuts, bolts and gaskets for instrument and process side.

#### 1.14.00 Temperature Switch

01. Type : Inert gas filled-in
02. Sensing Element Material : Bellow / Bourdon AISI SS-316
03. Bulb Material : AISI SS-316
04. Capillary : Stainless steel armoured
05. Movement Material : AISI SS-304
06. Case material : Epoxy coated steel plate or die-cast aluminum alloy with neoprene gasket and



Development Consultants Pvt. Ltd.

Page 19 of 169

**Volume : II-E**  
**Section : VI**  
**Control & Instrumentation**  
**Systems**

**WBPDCCL**

**EPC Bid Document**  
**Sagardighi Thermal Power Project**  
**1x660 MW Unit No. 5, Phase - III**

clear glass where applicable cover conforming to IP-65. (Explosion proof for NEC Class-1, Division 1 area).

- |     |                       |   |  |
|-----|-----------------------|---|--|
| 07. | Scale                 | : | Black lettering on white background  |
| 08. | Over range Protection | : | 120 %  |
| 09. | Instrument connection | : | Bottom   |
| 10. | Switch configuration  | : | Two SPDT   |
| 11. | Switch rating         | : | 240V, 5A AC/220V, 0.5A DC  |
| 12. | Switch type           | : | Snap acting, shock and vibration-proof.  |
| 13. | Adjustability         | : | Internal Set point adjustable over span range  |
| 14. | Elect connection      | : | Plug in socket   |
| 15. | Compensation          | : | a) Capillary compensation with invar wire throughout the capillary length.<br>b) Case compensation |
| 16. | Performance           | : |  |
|     | i) Scale Accuracy     | : | $\pm 1.0$ % of full scale  |
|     | ii) Repeatability     | : | < 0.5 % of full range  |
|     | iii) Response time    | : | Less than 40 seconds with thermowell   |
| 17. | Capillary length      | : | 5 meters (minimum) for local mounting/15 meters for local panel mounting.                          |
| 18. | Nameplate             | : | Tag number, service engraved in stainless steel tag plate  |
| 19. | Accessories           | : | Thermowell from SS barstock, Mounting accessories, 1/2" NPT cable gland.                           |

#### 1.15.00 Level Switch

- |     |                    |   |   |
|-----|--------------------|---|---|
| 01. | Type               | : | External cage float operated. Magnetically coupled.   |
| 02. | Float Material     | : | AISI-316 stainless steel or better  |
| 03. | Other wetted parts | : | AISI-316 stainless steel or better  |
| 04. | External Cage      | : | Carbon steel / Stainless steel or better as per process requirements, welded type / flanged |



**WBPDC**

**EPC Bid Document**  
**Sagardighi Thermal Power Project**  
**1x660 MW Unit No. 5, Phase - III**

construction. Cage pressure rating shall equal or exceed the rating of the main vessel.

- |     |                              |   |   |
|-----|------------------------------|---|---|
| 05. | External cage mounting       | : | Side-Side.  |
| 06. | External cage connection     | : | 25 NB socket welded.  |
| 07. | Switch housing               | : | Epoxy coated die-cast aluminum alloy with neoprene gasket conforming to IP-65. (Explosion proof for NEC Class-1, Division 1 area).  |
| 08. | Type of switch configuration | : | 2 SPDT (two nos.)   |
| 09. | Contact rating               | : | 5A, 240V/AC, 0.25A, 220V DC   |
| 10. | Accessories                  | : | <ul style="list-style-type: none"> <li>a) Counter flange, nuts &amp; bolts, suitable gasket etc.</li> <li>b) Steel globe type drain valve.</li> <li>c) ½"NPT cable gland</li> <li>d) Stainless steel alpha-numeric engraved for service and tag.</li> <li>e) Globe drain valve</li> </ul> |
| 11. | Preferred feature            | : | Switch operating point marked on cage   |
| 12. | Mounting                     | : | On standpipe  |

#### 1.16.00 Conductivity Type Level Switch

- |     |              |   |  |
|-----|--------------|---|--|
| 01. | Type         | : | Conductivity discrimination.   |
| 02. | Application  | : | Drain pots viz. on CRH line  |
| 03. | Mounting     | : | Flanged – on external cage.  |
| 04. | Probe MOC    | : | Stainless steel with high purity ceramic.  |
| 05. | Probe rating | : | > Maximum design pressure of vessel.   |
| 06. | Input        | : | Four independent channel with selectable switching threshold for water conductivity. |
| 07. | Relay Output | : | Four isolated output relays for Hi, Lo, Hi-Hi, Lo-Lo.                                |



**WBPDC**

**EPC Bid Document**  
**Sagardighi Thermal Power Project**  
**1x660 MW Unit No. 5, Phase - III**

08. Contact type & rating : 2SPDT or 1 DPDT @ 5A 30V DC.
09. Local Display : Coloured LEDs for Hi, Lo, Hi-Hi, Lo-Lo, Power & fault.
10. Power supply : Dual 240V AC, 50 Hz, 1Ph UPS supply.
11. Enclosure : IP-65, corrosion resistant & wall mounting type (Explosion proof for NEC Class-1, Division-1 area).
12. Accessories :
  - a) PTFE cable from probe to electronics
  - b) Mounting accessories
  - c) External cage
  - d) Washer & gasket
13. Test pressure : Two times rated pressure
14. Elect connection : Plug in socket

#### 1.17.00 Capacitance Type Level Switch

01. Type : Capacitance type
02. Probe :
  - a) Rod or suspended electrode
  - b) Rope type probes may be used only where required probe length is greater than 1.5 meters.
  - c) Reference rod for non grounded tank.
03. Probe Mounting : 1-1/2" Flanged
04. Material of construction : 316 SS and to suit fluid type
05. Insulation : PTFE/PP/Kynar Part/Full as required
06. Enclosure : Powder coated Die cast aluminium. with neoprene gasket conforming to IP-65. (Explosion proof for NEC Class-1, Division 1 area).
07. Ambient temperature : 0-60°C.
08. Mounting : Top Mounting
09. Supply voltage : 240V AC, 50 Hz, 1Ph UPS supply/ 24V DC



**WBPDCCL**

**EPC Bid Document**  
**Sagardighi Thermal Power Project**  
**1x660 MW Unit No. 5, Phase - III**

10. Relay output : 2 SPDT
11. Contact rating : 5A min. at 240V AC on resistive load
12. Response time : 100 msec or better
13. Elect connection : Plug in socket
14. Accessories : Counter flange, cable gland, prefab cable and stainless steel name plate engraved with alpha-numeric.

#### 1.18.00 RF Type Level Switch

- Sensing Probe :
01. Type : Rigid
  02. Material : SS-316
  03. Mounting : Threaded
  04. Probe Head Housing : Cast Aluminium
  05. Protection : IP-66
- Electronic Controller :
01. Supply Voltage : 240V AC (UPS)
  02. Relay Output : 2 nos. SPDT
  03. Contact Rating : 240V AC,5A/ 220V DC, 0.25A
  04. Housing Material : Cast Aluminium
  05. Protection : IP-65
  06. Local LED Indication : Power On, Alarm Level, Probe Healthy
  07. Switching Repeatability :  $\pm 0.5\%$
  08. Accessories : Coaxial cable probe connection to controller  
1/2"NPT Cable Gland

#### 1.19.00 Ultrasonic Level Switch

01. Principle of operation : Ultrasonic contact level technology
02. Input Power : 24V DC/ 240V AC



**WBPDC**

**EPC Bid Document  
Sagardighi Thermal Power Project  
1x660 MW Unit No. 5, Phase - III**

- |     |                    |   |   |
|-----|--------------------|---|---|
| 03. | Output Contact     | : | 2 SPDT (240V AC, 5A/ 220V DC, 0.25A)  |
| 04. | Switch Mounting    | : | Integral  |
| 05. | Sensor Material    | : | SS-316  |
| 06. | Enclosure          | : | Cast Aluminium (IP-65)  |
| 07. | Process Connection | : | 2" Flanged  |
| 08. | Repeatability      | : | 2 mm  |
| 09. | Power supply       | : | 240V AC, 50 Hz, 1Ph UPS supply/ 24V DC  |
| 10. | Cable connection   | : | ½" NPT with cable gland   |
| 11. | Accessories        | : | Cable gland, cable, companion flange, bolts & nuts, gaskets etc. along with all mounting hardware |

#### 1.20.00 Ultrasonic Level Transmitter

- |     |                             |   |   |
|-----|-----------------------------|---|---|
| 01. | Principle of operation      | : | Detection of reflected ultrasonic pulse                         |
| 02. | Signal processing           | : | Microprocessor Controlled Signal Processing                     |
| 03. | Type                        | : | Smart   |
| 04. | Display                     | : | Large alpha-numeric back lit LCD/LED                            |
| 05. | Calibration & configuration | : | Accessible from front of panel                                  |
| 06. | Diagnostic                  | : | On-line   |
| 07. | Status                      | : | For power, Hi / Lo / V. Hi / V. Lo-level indication, fault etc. |
| 08. | Construction                | : | Plug-on board   |
| 09. | Power supply                | : | 240V AC, 50 Hz, 1Ph UPS supply/ 24V DC                          |
| 10. | Signal Output               | : | 4-20 mA DC (isolated) - 500 Ohm load with HART protocol.        |
| 11. | Hysteresis                  | : | Fully adjustable preferred                                      |
| 12. | Output contacts             | : | 2SPDT Potential free changeover contacts @ 5A 230V AC.          |



**WBPDC**

**EPC Bid Document**  
**Sagardighi Thermal Power Project**  
**1x660 MW Unit No. 5, Phase - III**

13. Accuracy & Repeatability : 0.25% of span or better
14. Resolution : 0.1% of span
15. Operating temp. : Transmitter- 0 to 50° C and Sensor 0 to 80° C
16. MOC Sensor : SS 316 in general / PTFE, PP for corrosive application.
17. Humidity : 1% to 95% non condensing.
18. Enclosure : IP-65 powder coated die cast aluminium
19. Cable connection : ½” NPT with cable gland
20. Mounting : 2” flanged for sensor and Transmitter on panel / surface.
21. Accessories : Cable gland, prefab cable, mounting accessories.

#### 1.21.00 Conductivity Type E lectronic Level Indicator

01. Type : Conductivity discrimination.
02. Application : Separator drum Level .
03. No. of Probes : As per manufacturer standard.
04. Probe Mounting : Flanged – on standpipe.
05. Probe MOC : Stainless steel with high purity ceramic.
06. Probe rating : > Maximum design pressure of vessel.
07. Input : Independent channel with selectable switching threshold for water conductivity.
08. Relay Output : Four isolated output relays for Hi, Lo, Hi-Hi, Lo-Lo.
09. Contact type & rating : 2 SPDT or 1 DPDT @ 5A 30V DC.
10. Current output : Isolated 4-20 mA DC
11. Local Display : a) Coloured (Red & Green) LEDs for level.  
b) Flashing LEDs for fault.
12. Remote Display : Red, Green & flashing yellow LEDs for steam, Water & Fault indication respectively.



**WBPDCCL**

**EPC Bid Document**  
**Sagardighi Thermal Power Project**  
**1x660 MW Unit No. 5, Phase - III**

13. Power supply : Dual 240V AC, 50 Hz, 1Ph UPS supply.
14. Enclosure : a) IP-65, corrosion resistant & wall mounting type for local electronics.  
 b) IP-42 for remote indicator
15. Accessories : a) PTFE cable from probe to electronics  
 b) Mounting accessories.  
 c) Standpipe  
 d) Washer & gaskets  
 e) Double isolation valves on each connection, double drain valves & double vent valves with mechanical lock.  
 f) ½" NPT cable gland
16. Test pressure : Two times design pressure

1.22.00

**Air Filter Regulator**

01. Filter Element : Sintered Bronze
02. Filter Size : 5 microns
03. Input Air : 10.0 Kg/Sq. cm (maximum)
04. Output : Adjustable from 0-2.0 Kg / Sq. cm or 0-7.0 Kg / Sq. cm (continuous) as applicable.
05. Effect of Supply : Maximum 0.02 Kg/Sq. cm for a change pressure variation in supply pressure of 4 Kg/Sq. cm
06. Bowl Material : Metallic.
07. Accessories : 2" dial size output pressure gauge
08. Feature : No perceptible drop of pressure on opening the drain port.

1.23.00

**SOLENOID VALVE**

01. Operating Principle : Electromagnetic (noiseless)
02. Coil voltage rating : 24V DC (in general) other 220V DC /240V AC /110V AC as required



**WBPDC**

**EPC Bid Document**  
**Sagardighi Thermal Power Project**  
**1x660 MW Unit No. 5, Phase - III**

- |     |                     |   |   |
|-----|---------------------|---|---|
| 03. | Ways                | : | 3 ways in general other depending on requirement  |
| 04. | Port size           | : | 1/4" NPT all ports  |
| 05. | Body                | : | SS Bar Stock  |
| 06. | Trim                | : | AISI SS-316   |
| 07. | Manual Operator     | : | In built  |
| 08. | Duty                | : | Suitable for continuous energization  |
| 09. | Sealing             | : | Airtight and leak proofing with nitrile (NBR) and polyurethane (PUR) material   |
| 10. | Ambient Temperature | : | 0 - 50 <sup>o</sup> C   |
| 11. | Fluid Temperature   | : | 0-150 <sup>o</sup> C (approx.)  |
| 12. | Coil Enclosure      | : | Stainless Steel   |
| 13. | Insulation          | : | Class-H   |
| 14. | Coil Casing         | : | IP-65 (Explosion proof for NEC Class-1, Division-1 area)  |
| 15. | Response time       | : | 4-7msec   |
| 16. | Mounting            | : | On pipe or on panel   |
| 17. | Cable Connection    | : | 1/2" NPT cable gland  |
| 18. | Accessories         | : | Mounting brackets, nuts and bolts   |
| 19. | Special feature     | : | (i) LED indication for power<br><br>(ii) Double coil type for open & close operation of valve / damper.<br><br>(iii) Solenoid valve directly integral to actuator body shall have NAMOOR interface for uniformity |

1.24.00 ORIFICE PLATE

- |     |                   |   |   |
|-----|-------------------|---|---|
| 01. | Application       | : | Low fluid velocity flow measurement                                       |
| 02. | Design Standard   | : | Concentric as per ASME PTC-19.5 (Part –II), ISA RP-3.2 or BS-1042, Part-I |
| 03. | Number of Tapings | : | As required plus one additional pair of taps                              |
| 04. | Diameter Ratio    | : | Between 0.34 to 0.7   |



**WBPDC**

**EPC Bid Document**  
**Sagardighi Thermal Power Project**  
**1x660 MW Unit No. 5, Phase - III**

- |     |                |   |   |
|-----|----------------|---|---|
| 05. | Thickness      | : | 3mm for main pipe of diameter upto 250mm, 6mm for main pipe of diameter above 250mm and 10mm for diameter above 500 mm              |
| 06. | Document       | : | Beta ratio calculation, assembly drawing and Flow vs. DP curve.   |
| 07. | Meter run pipe | : | Same as pipe material   |
| 08. | Accessories    | : | Flanges, gaskets, nuts & bolts, root valves (1" 316 SS globe) jack screw, meter run pipe, Drain & vent hole as per application etc. |

1/2" SS316 globe



NOTE: One flow element of each type shall be calibrated in the test laboratory for validation of computed flow calculations.

#### 1.25.00 FLOW NOZZLE

- |     |                 |   |  |
|-----|-----------------|---|--|
| 01. | Application     | : | High fluid velocity flow measurement   |
| 02. | Design Standard | : | ASME PTC 19.5  |
| 03. | Tapings         | : | D and D/2 ( Numbers as required plus one additional pair of taps)  |
| 04. | Diameter Ratio  | : | Between 0.4 and 0.7  |
| 05. | Material        | : | 316 SS ( <del>321 SS for high temperature</del> )  |
| 05. | Document        | : | Beta ratio calculation, assembly drawing and Flow vs. DP curve.  |
| 06. | Meter run pipe  | : | Same as pipe material  |
| 07. | Accessories     | : | Meter run pipe, nipples and root valves (1" 316 SS globe).(Inspection port assembly for nozzles used in plant performance purpose) |

NOTE: One flow element of each type shall be calibrated in the test laboratory for validation of computed flow calculations.

#### 1.26.00 GAUGE GLASS

- |     |                 |   |  |
|-----|-----------------|---|--|
| 01. | Type            | : | Reflex   |
| 02. | Glass           | : | Toughened borosilicate. Resistant to mechanical and thermal shocks.              |
| 03. | Body material   | : | Carbon steel / stainless steel- As per process requirements (Flanged Connection) |
| 04. | Pressure rating | : | Twice the maximum working pressure   |



**WBPDCCL**

**EPC Bid Document**  
**Sagardighi Thermal Power Project**  
**1x660 MW Unit No. 5, Phase - III**

- 05. Temperature rating : 300° C
- 06. Bolts and nuts : Rust proof alloy steel
- 07. Accessories : Suitable ball check valves of SS-304/316 body, gaskets, companion flange etc.

1.27.00 LEVEL GAUGE (FLOAT & BOARD)

- 01. Type : Float and Board
- 02. Float & Tape MOC : AISI 316
- 03. Pulley and Pulley Housing material : SS 304
- 04. Guide wire : SS 316 Stainless steel
- 05. Accuracy : +/- 2 mm
- 06. Indication : Vertical dial
- 07. Rating : Twice the design pressure
- 08. Spring tension assembly : SS 304
- 09. Anchor plate : SS304
- 10. Calibrated scale board: Aluminium with black graduation

Note: The measuring rope/tape shall be passed through conduits

1.28.00 POWER CYLINDERS (PNEUMATIC)

- 01. Mounting Type : a) Fixed position mounting (End mounting).  
: b) Trunnion mounting
- 02. Control Signal : 4-20 mA DC to smart positioner with HART protocol for modulating purposes. 24V/48VDC operated solenoid valve operating on pneumatic line for open & closing purpose of on & off drive.
- 03. Supply Air : 0-7 Kg / Cm<sup>2</sup>.
- 04. Selection : Based upon thrust / torque, stroke length, angular movement, full-scale travel time, repeatability, space factor etc. Provision for air-to-open and air-to-close operation.
- 05. Casing : IP-65.



**WBPDCCL**

**EPC Bid Document**  
**Sagardighi Thermal Power Project**  
**1x660 MW Unit No. 5, Phase - III**

06. Accessories (as required) :
- a) Air lock relay
  - b) Hand wheel.
  - c) Air filter regulator with gauge.
  - d) Volume Booster.
  - e) Limit Switches.
  - f) Smart Positioner with integral I-P convertor, feedback position Transmitter (4-20 mA DC output), Input & Output pressure gauges, local keypad & display.
  - g) Solenoid Valve
  - h) Junction box with cable gland
07. Fail-safe operation : Stay put for regulating duty.
08. Repeatability : Better than 0.5% of full travel.
09. Hysterisis : Less than  $\pm 1\%$  of full travel
10. Operating Temp. limit : 80<sup>o</sup> C (min.)

1.29.00

**SIGHT GLASS**

01. Type : Flap-type
02. End connection : Screwed / Flanged
03. Material :
- a) Body : SS-304
  - b) Cover Plate : SS-304
  - c) Indicator : SS-316
04. Sight Glass : Toughened Borosilicate
05. Gasket : Neoprene
06. Bolts & Nuts : High tensile steel
07. Hydraulic Test
- Pressure : 1.5 times maximum working pressure
08. Accessories : As required

~~1.30.00~~~~**SMOKE DENSITY ANALYZER**~~

- ~~01. Type : Insitu dry visible light (through LED)

02. Principle of~~



**WBPDCCL**

**EPC Bid Document**  
**Sagardighi Thermal Power Project**  
**1x660 MW Unit No. 5, Phase - III**

05. Alarm/ Annunciation : Four Relay contacts, dual alarm set points (240V AC, 5A)
06. Indication : LCD Display
07. Sampling System : Extractive
08. Enclosure : IP-65
09. Power Supply : 240V AC (UPS)
10. Location : On Chimney
10. Accessories : a) Inbuilt calibration facility through calibrator. Inbuilt cell for Zero & Span calibration to be provided. Handling of Liquid Mercury to be avoided.  
 b) Remote calibration facility to be provided.  
 c) The Mercury analyser cabinet to be placed inside an enclosed AC environment.

#### 1.36.00 DEW POINT METER

01. Type : Direct mounting capacitance type with change in output proportional to moisture present
02. Sensing Element : Ceramic/ Aluminium Oxide sensor
03. Service : Dry Air
04. Range : -90 Deg.C to 10 Deg.C Dew point temperature
05. Sensor Accuracy :  $\pm 2$  Deg.C Dew point
06. Repeatability : 0.5 Deg.C Dew point
07. Op.Ambient Temperature : -40 Deg.C to 50 Deg.C
08. Op. Pressure : 0-10 Kg/cm<sup>2</sup>
09. Display : Combined enclosure with 5 digit seven segments LED display
10. Element Filter : 80 micron sintered stainless steel
11. Output : 4~20 mA DC loop powered
12. Power Supply : 24V DC nominal



**WBPDCCL**

**EPC Bid Document**  
**Sagardighi Thermal Power Project**  
**1x660 MW Unit No. 5, Phase - III**

- 13. Enclosure Class : IP-65
- 14. Interchangeability : Fully Interchangeable Transmitters
- 15. Accessories : Sampling System, cables, sensor holder, dessicant chambers, souble compression fittings, ¾" cable gland, mounting fixture etc.

1.37.00 DENSITY METER

- 01. Operating Principle : Vibration Density measurement
- 02. Wetted Part Material : SS-316L
- 03. Case Material : Cast Aluminium
- 04. Output : 4~20 mA DC
- 05. Electrical connection : ½" NPT
- 06. Enclosure Class : IP-65
- 07. Local Display : Digital 5 digit, density display with temp. compensation
- 08. Accuracy : ±1.0 %
- 09. Power Supply : 240V AC (UPS)
- 10. Location : At the discharge of Gypsum bleed pump in FGD system.

1.38.00 RADAR TYPE LEVEL MEASUREMENT

- 01. Type : Radar based on Time Domain Reflectometry
- 02. Antena : Co axial / single rod type guided wave or Horn type as required for the application
- 03. Communication : Two wire 4-20mA DC, HART protocol
- 04. Environmental temperature : 0 – 50°C
- 05. Enclosure : Explosion proof /IP 65 as per application
- 06. Cable Entry : ½" NPT
- 07. Calibration : a) Self calibration with internal reference  
b) Zero & Span calibration
- 08. Programming : Handheld programmer & Local key pad
- 09. Process Connection : Flanged /screwed



**WBPDCCL**

**EPC Bid Document**  
**Sagardighi Thermal Power Project**  
**1x660 MW Unit No. 5, Phase - III**

- |     |                    |  |
|-----|--------------------|--|
| 10  | Transmitter Beam   |  |
|     | Angle              | : 10 degree or less                          |
| 11  | Blocking distance  | : less than 300 mm                           |
| 12. | Electronic Housing | : Epoxy painted Die-Cast aluminium alloy     |
| 13. | Antenna / Flange   |  |
|     | assembly           | : 316 SS or Hest alloy (as required)         |
| 14. | Output Indicator   | : Digital Integral Display (Backlit LCD/LED) |
| 15. | Accuracy           | : 5 mm or 0.1% of probe length               |
| 16. | Accessories        | : a) Programming tool kit<br>b) Gasket       |

1.39.00 CHLORINE LEAK DETECTOR

- |     |                       |                                      |
|-----|-----------------------|--------------------------------------|
| 01. | Type                  | : Electrochemical                    |
| 02. | Resolution            | : 0.1 ppm                            |
| 03. | Display Type          | : Digital Indicating Meter           |
| 04. | Operating Temperature | : 0-45°C                             |
| 05. | Alarm Contacts        | : Dual Alarm setpoints (240V AC, 5A) |
| 06. | Enclosure Class       | : IP-65                              |
| 07. | Mounting              | : Wall mounting                      |
| 08. | Power Supply          | : 240V AC                            |
| 09. | Output                | : 4-20 mA DC (600 Ω load)            |

1.40.00 RESIDUAL CHLORINE ANALYZER

- |     |              |  |
|-----|--------------|--|
| 01. | Type         | : Amperometric   |
| 02. | Electrode    | : Platinum/ Gold and copper electrode shall be provided with cell cleaning system                                |
| 03. | Display Type | : LCD in Analyzer Panel  |
| 04. | Range        | : 0 to 20.0 mg/L (ppm)   |
| 05. | Accuracy     | : 2% or better . The measurement accuracy shall not be affected by presence of treatment chemicals as chromates, |



**WBPDCCL**

**EPC Bid Document**  
**Sagardighi Thermal Power Project**  
**1x660 MW Unit No. 5, Phase - III**

phosphates, de-former highly polluted water, change in temperature etc.

- |     |                 |   |   |
|-----|-----------------|---|---|
| 06. | Sensitivity     | : | 0.01 mg/L   |
| 07. | Alarm Contacts  | : | Dual Alarm setpoints (240V AC, 5A)  |
| 08. | Enclosure Class | : | IP-65   |
| 09. | Power Supply    | : | 240V AC   |
| 10. | Output          | : | 4-20 mA DC (600 $\Omega$ load)  |
| 11. | Calibration     | : | Zero & Span adjustment. Final calibration adjustments of the analyzer to be done at site and duly verified bt titration. Temperature compensation range 0-50°C. |
| 12. | Mounting        | : | Field mounting conform to IP-65   |
| 13. | Accessories     | : | Chemical reagents, sample drain, pumping system (if required) etc.  |

#### 1.41.00 ELECTRIC TO PNEUMATIC (E/P) CONVERTERS

- |     |                      |   |   |
|-----|----------------------|---|---|
| 01. | Air Supply           | : | 1.5 kg/cm <sup>2</sup>                                    |
| 02. | Max. supply Pressure | : | 7 kg/cm <sup>2</sup>                                      |
| 03. | Input Signal         | : | 4-20 mA DC (as required by the design of control system). |
| 04. | Output Signal        | : | 0.2 to 1.0 kg/cm <sup>2</sup>                             |
| 05. | Control Action       | : | Air to Close, Air to Open and Fail freeze-field selegable |
| 06. | Response Time        | : | 5 seconds for 0 to 90% output pressure                    |
| 07. | Repeatability        | : | +/- 0.1% span typical                                     |
| 08. | Accuracy             | : | +/- 0.25% span typical                                    |
| 09. | Linearity            | : | 0.5% of span or better                                    |
| 10. | Hysteresis           | : | 0.1% of span or better                                    |
| 11. | Ambient Temp.        | : |   |
|     | effect               | : | Less than 0.02% of span per °C between                    |



**WBPDCCL**

**EPC Bid Document**  
**Sagardighi Thermal Power Project**  
**1x660 MW Unit No. 5, Phase - III**

-20 °C to +60 °C

12. Supply pressure effect: less than 1%
13. Span and zero adjustment : screw
14. Mounting : Close to Actuator (but not on the actuator)
15. Output Capacity : To suit the actuator
16. Protection Class : IP 65
17. Allowable Drift Rate : ± 2% of set point / hour maximum

On loss of control signal, the last set point pressure shall be maintained so that the associated control valve remains in stay put condition.

#### 1.42.00 SMART POSITIONER

01. Type : Universal design (linear or rotary application)
02. Input Signal : 4-20mA DC , 2 wire loop with 24V DC.
03. Output Signal (position F/B) : i) 4-20mA  
ii) Configurable end position switch
04. Supply Pressure : Single acting 1.2 to 7.0 bar  
Double acting 1.2 to 10.5 bar
05. Air Delivery : Single acting 10.0 SCFM at 2.1 bar supply  
Double acting 7.2 SCFM at 2.1 bar supply
06. Housing : IP 65
07. Repeatability : +/- 0.3% of span or better
08. Accuracy : +/- 0.1% of span or better
09. Communication : Hart protocol
10. Power-up with position : < 150 ms or better control
11. Power interruption without reset : <100ms or better
12. Body Material : Aluminium
13. Response Time : Less than 10 sec

