

**TELANGANA STATE POWER GENERATION CORPORATION
LIMITED (TSGENCO)**

**5X800 MW TSGENCO YADADRI TPS (STAGE 2)
PART 3**

TECHNICAL SPECIFICATION

FOR

VENTILATION SYSTEM

**SPECIFICATION NO.: - PE-TS-417-554-A003
(REV 00)**



**BHARAT HEAVY ELECTRICALS LIMITED
POWER SECTOR
PROJECT ENGINEERING MANAGEMENT
SECTOR-16A, PLOT NO.-25, NOIDA, INDIA**



TITLE:
5X800 MW YADADRI TPS
TECHNICAL SPECIFICATINS FOR
VENTILATION SYSTEM STAGE 2 (PART III-
AXIAL FANS)

SPECIFICATION No: PE-TS-417-554-A003

SECTION

REV. 00

DATE: JUL 23

SHEET : 1 OF 2

CONTENTS

This Technical specification consists of two sections:

SECTION - I

SUB- SECTIONS	TITLE	Page No		
Sub-Section-A	INTENT OF SPECIFICATION	4		
Sub-Section-B	PROJECT INFORMATION WITH WIND AND SEISMIC DESIGN CRITERIA	7		
Sub-Section-C	TECHNICAL SPECIFICATIONS			
	Sub Section-C1	SPECIFIC TECHNICAL REQUIREMENT	11	
	Sub Section-C2	CUSTOMER SPECIFICATION		
		C2 - B	PROJECT SPECIFIC GENERAL REQUIREMENTS INCLUDING:	23
			GENERAL TECHNICAL REQUIREMENT	
			FUNCTIONAL / PERFROMANCE / DEMOSTRATION / GUARANTEE TESTS	
			DRAWINGS / DOCUMENTS SUBMISSION PROCEDURE (Refer ANNEXURE-VI)	
	PACKING PROCEDURE			
C2 - C	PAINTING SPECIFICATIONS	71		
C3	ELECTRICAL SECTION	86		
Sub Section-E	ANNEXURE-I	LIST OF MAKES OF SUB-VENDOR ITEMS	107	
	ANNEXURE-II	MANDATORY SPARE LIST	116	
	ANNEXURE-III	PAINTING & COLOUR SCHEME	117	
	ANNEXURE-IV	LIST OF TOOLS & TACKLES	118	
	ANNEXURE-VI	DRAWINGS / DOCUMENTS SUBMISSION PROCEDURE	120	
	ANNEXURE-VIII	OPERATION AND MAINTENANCE MANUAL	121	
	ANNEXURE-IX	SITE STORAGE AND PRESERVATION	125	
	ANNEXURE-X	PACKING PROCEDURE (Refer SECTION C2-B)	-	



TITLE:
5X800 MW YADADRI TPS
TECHNICAL SPECIFICATINS FOR
VENTILATION SYSTEM STAGE 2 (PART III-
AXIAL FANS)

SPECIFICATION No: PE-TS-417-554-A003

SECTION

REV. 00

DATE: JUL 23

SHEET : 2 OF 2

SECTION - II

SUB SECTIONS	TITLE	Page No
Sub Section-2	LIST OF DOCUMENTS TO BE SUBMITTED WITH BID	142
Sub Section-3	COMPLIANCE CUM CONFIRMATION CERTIFICATE	143
Sub Section-4	PRE BID CLARIFICATION SCHEDULE	145
Sub Section-5	NO DEVIATION CERTIFICATE	146
Sub Section-6	MAKE DECLARATION BY BIDDER	147
Sub Section-7	GUARANTEE POWER CONSUMPTION	148
Sub Section-8	INPUT DRAWINGS	150



**5x800MW YADADRI STPP(STAGE 2)
VENTILATION SYSTEM(PART III)
INTENT OF SPECIFICATION**

SPECIFICATION No: PE-TS-417-554-A003

SECTION : I

Sub Section: A

REV. 00

JUL 23

SHEET 1 OF 3

SECTION-I

SUB-SECTION-A

INTENT OF SPECIFICATION



**5x800MW YADADRI STPP(STAGE 2)
VENTILATION SYSTEM(PART III)
INTENT OF SPECIFICATION**

SPECIFICATION No: PE-TS-417-554-A003

SECTION : I

Sub Section: A

REV. 00

JUL 23

SHEET 2 OF 3

1.0 INTENT OF SPECIFICATION

- 1.1 The specification covers Supply part, Services part and Mandatory spares comprising of preparation and submission of O&M manuals),, manufacture, fabrication, assembly, inspection / testing at vendor's & sub-vendor's works, painting, maintenance tools & tackles, fill of lubricants, and consumables required for pre-commissioning, commissioning , performance testing and till one year of operation after handing over, mandatory spares alongwith spares for erection, start-up and commissioning as required, forwarding, proper packing, shipment and delivery at site, unloading, handling, transportation & storage at site, in-site transportation, assembly, erection & commissioning, final painting at site, minor civil and structural work, trial run at site and carrying out Performance guarantee / Functional / Demonstration tests at site, and handover in flawless condition of the package to the BHEL's customer of **VENTILATION SYSTEM -AXIAL FANS with mandatory spares** as per details in different sections / volumes of this specification and various pre award agreements for **5X800 MW YADADRI TPS**
- 1.2 The contractor shall be responsible for providing all material, equipment & services, which are required to fulfil the intent of ensuring operability, maintainability, reliability and complete safety of the complete work covered under this specification, irrespective of whether it has been specifically listed herein or not. Omission of specific reference to any component / accessory necessary for proper performance of the equipment shall not relieve the contractor of the responsibility of providing such facilities to complete the supply, erection and commissioning, performance and guarantee/demonstration testing of **VENTILATION SYSTEM-AXIAL FANS**
- 1.3 It is not the intent to specify herein all the details of design and manufacture. However, the equipment shall conform in all respects to highest standards of design, engineering and workmanship and shall be capable of performing the required duties in a manner acceptable to purchaser who will interpret the meaning of drawings and specifications and shall be entitled to reject any work or material which in his judgement is not in full accordance herewith.
- 1.4 The extent of supply under the contract includes all items shown in the drawings, notwithstanding the fact that such items may have been omitted from the specification or schedules. Similarly, the extent of supply also includes all items mentioned in the specification and /or schedules, notwithstanding the fact that such items may have been omitted in the drawing. Similarly, the extent of supply also includes all items required for completion of the system and not withstanding that they may have been omitted in drawings / specifications or schedules.
- 1.5 The general term and conditions, instructions to tenderers and other attachment referred to elsewhere are made part of the tender specification. The equipment materials and works covered by this specification is subject to compliance to all attachments referred to in the specification. The bidder shall be responsible for and governed by all requirements stipulated herein.



**5x800MW YADADRI STPP(STAGE 2)
VENTILATION SYSTEM(PART III)
INTENT OF SPECIFICATION**

SPECIFICATION No: PE-TS-417-554-A003

SECTION : I

Sub Section: A

REV. 00

JUL 23

SHEET 3 OF 3

- 1.6 While all efforts have been made to make the specification requirement complete & unambiguous, it shall be bidders' responsibility to ask for missing information, ensure completeness of specification, to bring out any contradictory / conflicting requirement in different sections of the specification and within a section itself to the notice of BHEL and to seek any clarification on specification requirement in the format enclosed under SEC-II of the specification **within 10 days of receipt of tender documents**. In absence of any such clarifications, in case of any contradictory requirement, the more stringent requirement as per interpretation of Purchaser / Customer shall prevail and shall be complied by the bidder without any commercial implication on account of the same. Further in case of any missing information in the specification not brought out by the prospective bidders as part of pre-bid clarification, the same shall be furnished by Purchaser/ Customer as and when brought to their notice either by the bidder or by purchaser/ customer themselves. However, such requirements shall be binding on the successful bidder without any commercial & delivery implication.
- 1.7 The bidder's offer shall not carry any sections like clarification, interpretations and /or assumptions.
- 1.8 Deviations, if any, should be very clearly brought out clause by clause along with cost of withdrawal in the enclosed schedule (in Sec – II); otherwise, it will be presumed that the vendor's offer is strictly in line with NIT specification. If no cost of withdrawal is given against the deviation, it will be presumed that deviation can be withdrawn without any cost to BHEL/its customer.
- 1.9 In the event of any conflict between the requirements of two clauses of this specification documents or requirements of different codes and standards specified, Sub-Section - C shall prevail over Sub-section – D, however more stringent requirement as per the interpretation of the owner shall apply.
- 1.10 In case all above requirements are not complied with, the offer may be considered as incomplete and would become liable for rejection.
- 1.11 For definition of word like Contractor, bidder, supplier, vendor, Customer/ Purchaser Employer, consultant, please refer relevant clause of NIT.



**5X800 MW YADADRI TPS
VENTILATION SYSTEM
PROJECT INFORMATION WITH WIND AND
SEISMIC DESIGN CRITERIA**

SPECIFICATION No: PE-TS-417-554-A003

SECTION : I

Sub Section : B

REV. 0

DATE: .JUL 23

SECTION: I

SUB-SECTION: B

PROJECT INFORMATION

YADADRI THERMAL POWER STATION

PROJECT INFORMATION

1	Name of the Project	YADADRI Thermal Power Station
2	Station Capacity	5X800 MW (Coal based)
3	Owner	Telangana State Power Generation Corporation Limited (TSGENCO)
4	Site Location	Site is located 7 km from the NH5.
5	Latitude	16° 42'20.40 N
6	Longitude	79° 34'41.56 E
7	Nearest Town	30 Km Miryalaguda
8	Nearest Railway Station	6.5 Km Damercherla
9	Nearest Airport	130 Kms (Vijayawada)
10	Site Conditions	
	Ambient Temperature	
	Daily minimum (average)	10°C
	Daily maximum (average)	47°C
	Design Ambient Temperature	50°C
	Ambient temperature (performance)	38°C
	Relative Humidity for design / efficiency	48-84 %
	Annual rainfall, mm	600 mm
	Plant Elevation above MSL	85 m above MSL
	Mean Wind Speed	44 m/s
	Wind Pressure	As per the latest revision of IS 875/1987
	Seismic co-efficient	Zone-III as per IS- 1893 (Part-IV)

जलवायवी सारणी
CLIMATOLOGICAL TABLE

BACK

स्टेशन : नलगोंदा
STATION : Nalgonda

अक्षांश
LAT. 17°03'
देशांतर
LONG. 79°16'

समुद्री तल माध्य से ऊंचाई
HEIGHT ABOVE M.S.L. 227
मीटर
METRES

प्रक्षणां पर आधारित
BASED ON OBSERVATIONS 1975-2000

माह	स्टेशन का सतह दाब	वायु तापमान										आर्द्रता		मेघ की मात्रा		वर्षा								
		माध्य				चरम				आर्द्रता		मेघ की मात्रा		वार्षिक योग	वर्षा के दिनों की संख्या	वर्षा सहित सबसे नम महीने का योग	वर्षा रहित शुष्कतम महीने का योग	24 घंटों की सबसे भारी वर्षा	दिनांक और वर्ष	माध्य पवन गति				
		शुष्क बल्व	नम बल्व	दैनिक अधिकतम	दैनिक न्यूनतम	माह में उच्चतम	माह में निम्नतम	दिनांक और वर्ष	दिनांक और वर्ष	सापेक्ष आर्द्रता	वाष्प दाब	समस्त मेघ	निम्न मेघ											
MONTH	STATION LEVEL PRESSURE	AIR TEMPERATURE						HUMIDITY		CLOUD AMOUNTS		RAINFALL												
		MEAN				EXTREMES				RELATIVE HUMIDITY		ALL CLOUDS		MONTHLY TOTAL	NO. OF RAINY DAYS	TOTAL IN WETTEST MONTH WITH YEAR	TOTAL IN DRIEST MONTH WITH YEAR	HEAVIEST FALL IN 24 HOURS	DATE AND YEAR	MEAN WIND SPEED				
		DRY BULB	WET BULB	DAILY MAX	DAILY MIN	HIGHEST IN THE MONTH	LOWEST IN THE MONTH	HIGHEST	DATE AND YEAR	LOWEST	DATE AND YEAR	RELATIVE HUMIDITY	VAPOUR PRESSURE			ALL CLOUDS	LOW CLOUDS	mm	mm	mm	mm	mm	Km. मी. प्र. घं. Kmph	
	एच.पी.ए. hPa	डि. से °C	डि. से °C	डि. से °C	डि. से °C	डि. से °C	डि. से °C	डि. से °C	डि. से °C	डि. से °C	डि. से °C	प्रतिशत %	एच.पी.ए. hPa	आकाश के अछमारा Oktas of sky	मि.मि. mm		मि.मि. mm	मि.मि. mm	मि.मि. mm					
जनवरी JAN	I II	989.9	21.3	19.3	30.8	18.4	33.8	16.1	36.0	17	14.4	7	1992	82	21.2	2.0	1.8	13.5	0.4	155.7	0.0	55.4	11	1978
फरवरी FEB	I II	988.0	23.6	21.5	33.5	20.7	36.5	18.0	39.0	26	15.4	5	1988	82	24.1	3.0	2.5	7.2	0.5	14.0	0.0	49.2	20	2000
मार्च MAR	I II	985.8	26.2	23.7	37.3	22.8	40.9	19.9	42.0	14			1983	80	27.4	1.7	1.4	6.5	0.4	88.5	0.0	43.6	13	1981
अप्रैल APR	I II	983.6	29.2	25.5	39.6	25.5	43.0	22.4	44.5	30	14.6	15	1987	73	29.7	2.1	2.0	17.6	1.0	65.6	0.0	40.6	24	1981
मई MAY	I II	980.8	31.9	26.3	41.2	28.2	44.8	23.5	46.1	26			1984	63	29.7	2.7	2.5	27.0	1.4	94.3	0.0	49.0	5	1981
जून JUN	I II	978.2	29.8	25.7	37.6	27.2	42.6	23.4	46.3	2	21.8	12	1991	71	29.9	5.1	4.4	65.9	3.5	48.2	0.0	81.7	12	1991
जुलाई JUL	I II	978.8	27.7	24.7	33.9	25.5	37.3	23.2	39.2	7	22.0	2	1992	77	28.6	6.3	5.8	124.6	6.0	176.7	36.8	99.2	24	1977
अगस्त AUG	I II	979.6	27.1	24.3	32.8	25.0	35.4	22.8	37.5	25	22.0	2	1981	78	28.2	6.1	6.0	133.0	6.7	189.0	33.2	88.2	14	1977
सितम्बर SEP	I II	982.0	27.4	24.4	33.6	24.9	36.4	22.8	38.5	23	21.6	8	1989	77	28.3	4.9	4.2	145.5	5.8	393.1	20.3	152.2	21	1991
अक्टूबर OCT	I II	985.3	26.6	23.8	33.1	23.7	36.2	21.4	36.5	1	19.2	28	1980	78	27.2	4.0	3.7	104.3	3.8	333.1	4.2	109.2	6	1987
नवम्बर NOV	I II	987.9	24.2	21.0	31.1	21.2	33.5	17.9	35.5	7	14.6	27	1981	75	22.6	3.2	2.6	48.1	2.8	66.8	1.1	163.5	4	1987
दिसम्बर DEC	I II	990.3	21.7	18.6	30.0	18.6	32.2	15.7			12.6	16	1993	73	19.4	2.7	2.3	3.8	0.3	3.1	0.0	3.1	10	1987
वार्षिक योग या माध्य ANNUAL TOTAL OR MEAN	I II	983.9	26.7	23.4	34.8	23.7	44.3	15.9	46.3	2	12.6	16		75	26.6	3.7	3.2	696.8	32.5	631.7	631.7	163.5	4	
वर्षों की सं NUMBER OF YEARS	I II	19	19	19	19	19	21	22	19	19				19	19	18	17	20	20	16	16	23		

जलवायवी सारणी
CLIMATOLOGICAL TABLE

स्टेशन : बलानदा

STATION : Balgonda

		मौसम परिघटना						पवन											मेघ								दृश्यता										
		के साथ दिनों की संख्या						पवन की गती के साथ दिनों की संख्या (कि. मी. प्र. घं.)				पवन की दिशा के दिनों की संख्या का प्रतिशत							मेघ मात्रा (सभी मेघ) सहित दिनों की संख्या - अष्टमांश				निम्न स्तरी मेघ मात्रा सहित दिनों की संख्या - अष्टमांश				दृश्यता सहित दिनों की संख्या										
माह	वर्षण 0.3 मि.मि.या अधिक	ओले	गर्जन	कुहरा	धूल भरी आंधी	चंड वात	62 या अधिक	20-61	1-19	0	उ	उपू	पू	दपू	द	दप	प	उप	शांत	0	ले-2	3-5	6-7	8	0	ले-2	3-5	6-7	8	कुहरा 8	1 कि.मी. तक	1-4 कि.मी.	4-10 कि.मी.	10-20 कि.मी.	20 कि.मी. से अधिक		
																																				WEATHER PHENOMENA	
MONTH		No. OF DAYS WITH						No. OF DAYS WITH WIND SPEED (Km. p. h.)				PERCENTAGE No. OF DAYS WIND FROM							No. OF DAYS WITH CLOUD AMOUNT (ALL CLOUDS) O K T A S				No. OF DAYS WITH LOW CLOUD AMOUNT O K T A S				No. OF DAYS WITH VISIBILITY										
		PFT 0.3 mm Or more	HAIL	THUN DER	FOG	DUST STORM	SQU ALL	52 Or more	20-61	1-19	0	N	NE	E	SE	S	SW	W	NW	CALM	0	T-2	3-5	6-7	8	0	T-2	3-5	6-7	8	FOG 8	UP TO 1 Km.	1-4 Kms	4-10 Kms.	10-20 Kms	OVER 20 Kms.	
जनवरी JAN	0.5	0.0	0.0	0.0	0.0	0.0	0	0	29	2	0	30	3	39	3	4	0	11	10	25	0	2	1	3	25	0	2	1	3	0	0.6	6.7	21.3	2.3	0.1		
फरवरी FEB	0.6	0.0	0.0	0.0	0.0	0.0	0	0	28	0	1	26	1	55	3	5	0	7	2	18	1	3	2	4	21	1	2	1	3	0	0.1	7.8	18.0	1.7	0.5		
मार्च MAR	0.7	0.0	0.1	0.0	0.0	0.0	0	1	30	0	1	25	1	55	3	5	0	9	1	23	2	3	1	2	26	1	2	1	1	0	0.0	3.8	24.1	2.9	0.3		
अप्रैल APR	1.1	0.0	0.0	0.0	0.0	0.0	0	0	29	1	0	20	1	46	4	18	0	8	3	20	2	4	2	2	21	1	4	2	2	0	0.0	3.0	21.5	4.3	1.1		
मई MAY	1.8	0.0	0.0	0.0	0.0	0.0	0	0	31	0	1	14	0	27	3	21	3	30	1	19	2	5	2	3	21	2	4	1	3	0	0.0	3.1	22.5	3.4	1.9		
जून JUN	4.5	0.0	0.0	0.0	0.0	0.0	0	1	29	0	1	2	0	6	0	36	8	47	0	5	1	5	4	15	7	1	4	3	15	0	0.0	4.7	20.2	3.1	2.0		
जुलाई JUL	7.1	0.0	0.1	0.0	0.0	0.0	0	1	30	0	1	1	0	1	0	43	10	44	0	2	1	3	5	20	4	1	2	3	21	0	0.0	4.3	23.1	1.9	1.6		
अगस्त AUG	7.7	0.0	0.0	0.0	0.0	0.0	0	1	30	0	1	1	0	2	0	32	8	55	1	2	1	5	3	20	3	1	4	2	21	0	0.0	4.1	22.8	2.5	1.6		
सितम्बर SEP	6.6	0.0	0.0	0.0	0.0	0.0	0	0	29	1	1	6	0	11	1	29	4	42	6	4	1	6	4	15	5	1	4	3	17	0	0.0	3.2	20.9	3.6	2.3		
अक्टूबर OCT	3.9	0.0	0.0	0.0	0.0	0.0	0	0	29	2	1	29	4	16	1	15	2	23	9	18	1	5	2	5	21	0	3	2	5	0	0.1	3.7	22.4	3.8	1.1		
नवम्बर NOV	3.3	0.0	0.0	0.0	0.0	0.0	0	0	26	4	3	33	7	18	2	4	0	19	14	16	1	4	3	6	21	1	2	2	4	0	0.0	8.8	17.8	2.9	0.4		
दिसम्बर DEC	0.4	0.0	0.0	0.0	0.0	0.0	0	0	29	2	3	46	3	22	1	2	1	14	8	21	1	4	1	4	23	1	3	1	3	0	0.1	6.8	20.8	3.3	0.0		
वार्षिक योग या माध्य ANNUAL TOTAL OR MEAN	39.3	0.0	0.1	0.0	0.0	0.0	1	5	346	13	1	19	2	24	2	18	3	26	5	205	13	46	29	70	238	11	37	22	57	0	0.8	60.1	255.4	35.6	13.0		
वर्षोंकी सं NUMBER OF YEARS																																					
		22						22																													



**SPECIFIC TECHNICAL REQUIREMENT
FOR VENTILATION SYSTEM STAGE 2 (PART
III- AXIAL FAN)**

SECTION – I

REVISION 00

DATE: JUL 23

SUB SECTION: C1A

**SECTION: I
SUB SECTION – C1A
SPECIFIC TECHNICAL REQUIREMENT FOR VENTILATION
SYSTEM**



**SPECIFIC TECHNICAL REQUIREMENT
FOR VENTILATION SYSTEM STAGE 2 (PART
III- AXIAL FAN)**

SECTION – I

REVISION 00

DATE: JUL 23

SUB SECTION: C1A

1.0 Specific requirement

Mechanical Requirements

Engineering of Axial fans for most of the buildings has been completed.

Bidder to refer approved Fan schedule attached in input drawings (Section - 8 of this specification for details. In addition to this, GA drawing for axial fans such as Roof extractor fans, Axial Supply Fans, Axial Exhaust fans, Propeller is also approved and attached in this specification. In case bidder offers makes of these fans as per already approved drawing (refer table 1 below for approved makes), bidder is not required to submit these drawings/documents afresh. However, bidder shall be required to endorse the approved documents attached in sub section 8 (Appendix 1) during detail engineering.

Further, it may be noted that bidder has the option to offer different makes (other than those for which drawings/ documents have been attached in the specification) for these items from the list of makes of sub vendor items attached at Sub Section E. In such a scenario, Bidder will have to submit Engineering document for such items in line with details mentioned in respective equipment GA/documents attached at Appendix 1. However, any data which is proprietary in nature or standard for the model offered by OEM or not specifically insisted in this tender specification of the respective equipment may be updated/ modified suitably.

Table 1

Sl no.	Equipment	Make already approved	Document number/Remarks
1	Roof Extractor and its accessories	AVPL	For details Refer Appendix 1
2	Axial Supply/Exhaust fan and its accessories	AVPL	
3	Motors for above RE fan /Axial fans	LHP	
3	Filter	Puromatic	
4	Propeller fan	Khaitan	



**SPECIFIC TECHNICAL REQUIREMENT
FOR VENTILATION SYSTEM STAGE 2 (PART
III- AXIAL FAN)**

SECTION – I

REVISION 00

DATE: JUL 23

SUB SECTION: C1A

Civil Requirements

Bidder to note that civil details (mentioned in table below) have already been finalized based on attached mechanical drawings and are under various stages of construction by BHEL. Bidder to plan and supply axial Fans and its associated systems such as Filters, Cowls, Bird Mesh, wire mesh, mounting duct, mounting sleeve, Support Structure etc as per already provided openings for powerhouse, ESP building and other offsite buildings. Any change required by bidder in these civil facilities during erection shall be carried out by bidder themselves.

1.	Roof extractor units with 15 mmwc static pressure.		
	Capacity	Motor rating	Roof / Slab opening
a.	50,000 CMH	5.5 KW	1320 Ø mm
b.	40,000 CMH	5.5 KW	1320 Ø mm
c.	20,000 CMH	2.2 KW	1000 Ø mm
2.	Axial flow supply fans with 30 mmwc static pressure.		
	Capacity	Motor rating	Wall opening
a.	10,000 CMH	2.2 KW	1000mmx1000mm
b.	7,500 CMH	1.5 KW	1000mmx1000mm
c.	6,000 CMH	1.1 KW	600mmx600mm
d.	4,000 CMH	0.75 KW	500mmx500mm
3.	Axial flow supply fans with 20 mmwc static pressure.		
	Capacity	Motor rating	Wall opening
a.	10,000 CMH	1.5 KW	1000mmx1000mm
b.	7,500 CMH	1.1 KW	1000mmx1000mm
c.	6,000 CMH	1.1 KW	600mmx600mm
d.	4,000 CMH	0.75 KW	600mmx600mm
4.	Axial flow exhaust fans (Bifurcated type) with 15 mmwc static pressure.		
	Capacity	Motor rating	Wall opening
a.	15,000 CMH	2.2 KW	1000mmx1000mm
b.	10,000 CMH	1.5 KW	1000mmx1000mm



**SPECIFIC TECHNICAL REQUIREMENT
FOR VENTILATION SYSTEM STAGE 2 (PART
III- AXIAL FAN)**

SECTION – I

REVISION 00

DATE: JUL 23

SUB SECTION: C1A

c.	7,500 CMH	1.1 KW	1000mmx1000mm
d.	6,000 CMH	1.1 KW	700mmx700mm
e.	4,000 CMH	0.75 KW	700mmx700mm
e.	2,000 CMH	0.55 KW	700mmx700mm
5	Axial flow exhaust fans (Bifurcated type) with 25 mmwc static pressure.		
	Capacity	Motor Rating	Wall Opening
a.	20,000 CMH	2.2 KW	1000mmx1000mm
b	15,000 CMH	1.5 KW	1000mmx1000mm
6	Axial flow exhaust fans with 10 mmwc static pressure.		
	Capacity	Motor rating	Wall opening
a.	15,000 CMH	1.1 KW	900mmx900mm
b.	10,000 CMH	0.75 KW	900mmx900mm
c.	7,500 CMH	0.55 KW	700mmx700mm
d.	6,000 CMH	0.55 KW	700mmx700mm
e.	2,000 CMH	0.37 KW	500mmx500mm
7	Exhaust fan (propeller type) with 5 mmwc static pressure.		
	Capacity	Motor rating	Wall opening
a.	1200 CMH	100 W	380 mm circular



**SPECIFIC TECHNICAL REQUIREMENT
FOR VENTILATION SYSTEM STAGE 2 (PART
III- AXIAL FAN)**

SECTION – I

REVISION 00

DATE: JUL 23

SUB SECTION: C1A

Electrical Requirements

Bidder to note that electrical details have already been finalized based on attached mechanical drawings. For supply of miscellaneous electrical items viz. cable lugs, glands etc. bidder may refer motor drawings attached with this specification for typical details. Power Feeder details of motors are mentioned in Fan Schedule. Disregard of the final make of the equipment selected by the bidder, electrical feeder list has to be complied by the bidder.

Bidder shall refer below details for Electrical scope spilt of Electrical items between BHEL & vendor,

ELECTRICAL SCOPE BETWEEN BHEL AND VENDOR

PACKAGE: VENTILATION SYSTEM

S.NO	DETAILS	SCOPE SUPPLY	SCOPE E&C	REMARKS
1	415V MCC	BHEL	BHEL	240 V AC (supply feeder)/415 V AC (3 PHASE 4 WIRE) supply shall be provided by BHEL based on load data provided by vendor at contract stage for all equipment supplied by vendor as part of contract. Any other voltage level (AC/DC) required will be derived by the vendor.
2	Local Push Button Station (for motors)	BHEL	BHEL	Located near the motor.
3	Power cables, control cables and screened control cables for a) both end equipment in BHEL's scope b) both end equipment in vendor's scope c) one end equipment in vendor's scope	BHEL BHEL BHEL	BHEL Vendor BHEL	1. For 3.b) & c): Sizes of cables required shall be informed by vendor at contract stage (based on inputs provided by BHEL) in the form of cable listing. Finalisation of cable sizes shall be done by BHEL. Vendor shall provide lugs & glands accordingly. 2. Termination at BHEL equipment terminals by BHEL. 3. Termination at Vendor equipment terminals by Vendor.
4	Junction box for control & instrumentation cable	Vendor	Vendor	Number of Junction Boxes shall be sufficient and positioned in the field to minimize local cabling (max 10-12 mtrs) and trunk cable.
5	Any special type of cable like compensating, co-axial, prefab, MICC, fibre optical etc.	Vendor	Vendor	Refer C&I portion of specification for scope of fibre Optical cables if used between PLC/ microprocessor & DCS.
6	Cable trays, accessories & cable trays supporting system 100/ 50 mm cable trays/ Conduits/ Galvanised steel cable troughs for local cabling	BHEL Vendor	BHEL Vendor	Local cabling from nearby main route cable tray (BHEL scope) to equipment terminal (vendor's scope) shall be through 100/ 50 mm. cable trays/ conduits/ Galvanised steel cable troughs, as per approved layout drawing during contract stage.
7	Cable glands, lugs and bimetallic strip for equipment supplied by Vendor	Vendor	Vendor	1. Double compression Ni-Cr plated brass cable glands 2. Solder less crimping type heavy duty tinned copper lugs for power and control cables.
8	Conduit and conduit accessories for cabling between equipments supplied by vendor	Vendor	Vendor	Conduits shall be medium duty, hot dip galvanised cold rolled mild steel rigid conduit as per IS: 9537.
9	Lighting	BHEL	BHEL	
10	Equipment grounding & lightning protection	BHEL	BHEL	Refer note no. 4 for electronic earthing
11	Below grade grounding	BHEL	BHEL	
12	LT Motors with base plate and foundation hardware	Vendor	Vendor	Makes shall be subject to customer/ BHEL approval at contract stage.
13	Mandatory spares	Vendor	-	Vendor to quote as per specification.
14	Recommended O & M spares	Vendor	-	As specified elsewhere in specification



**SPECIFIC TECHNICAL REQUIREMENT
FOR VENTILATION SYSTEM STAGE 2 (PART
III- AXIAL FAN)**

SECTION – I

REVISION 00

DATE: JUL 23

SUB SECTION: C1A

ELECTRICAL SCOPE BETWEEN BHEL AND VENDOR

PACKAGE: VENTILATION SYSTEM

S.NO	DETAILS	SCOPE SUPPLY	SCOPE E&C	REMARKS
15	Any other equipment/material/service required for completeness of system but not specified above (to ensure trouble free and efficient operation of the system).	Vendor	Vendor	
16	a) Input cable schedules (Control & Screened Control Cables) b) Cable interconnection details for above c) Cable block diagram	Vendor Vendor Vendor	- - -	Cable listing for Control and Instrumentation Cable and electronic earthing cable in enclosed excel format shall be submitted by vendor during detailed engineering stage.
17	Electrical Equipment & cable tray layout drawings	Vendor	-	For ensuring cabling requirements are met, vendor shall furnish Electrical equipment layout & cable tray layout drawings (both in print form as well as in AUTOCAD) of the complete plant (including electrical area) indicating location and identification of all equipment requiring cabling, and shall incorporate cable trays routing details marked on the drawing as per PEM interface comments. Cabling arrangement of the same (wherever overhead cable trays, trenches, cable ducts, conduits etc.) shall be decided during contract stage. Electrical equipment layout & cable tray layout drawing shall be subjected to BHEL/ customer approval without any commercial implications to BHEL.
18	Electrical Equipment GA drawing	Vendor	-	For necessary interface review.

NOTES:

1. Make of all electrical equipment/ items supplied shall be reputed make & shall be subject to approval of BHEL/customer after award of contract.
2. All QPs shall be subject to approval of BHEL/customer after award of contract without any commercial implication.
3. In case the requirement of Junction Box arises on account of Power Cable size mis-match due to vendor engineering at later stage, vendor shall supply the Junction Box for suitable termination.
4. Vendor shall indicate location of Electronic Earth pit in their Civil assignment drawing.



**SPECIFIC TECHNICAL REQUIREMENT
FOR VENTILATION SYSTEM STAGE 2 (PART
III- AXIAL FAN)**

SECTION – I

REVISION 00

DATE: JUL 23

SUB SECTION: C1A

2.0 EQUIPMENT AND SERVICES PROVIDED FOR VENTILATION SYSTEM:

2.1 Wall mounted axial flow fan

Each wall mounted axial flow fan shall be complete with following typical items

(Refer approved drawing in drawing section for details)

- a) Fan impeller & casing/short duct as required.
- b) Electric drive motor with coupling if any, including motor brackets.
- c) Inlet cone and grouting framework, if any.
- d) Rain protection cowl with bird-screen (of GI Construction).
- e) Bird mesh/Wire mesh/mounting Sleeve ,Support Structure etc
- f) All supply air axial flow fans shall be provided with pre-filters (and also fine filters for MCC/switchgear room).

2.2 Roof Extractor unit

Each wall roof extractor unit shall be complete with following typical items

(Refer approved drawing in drawing section for details)

- a) Fan wheel, electric drive motor with motor coupling if any and motor bracket.
- b) Short duct mounting/axial fan casing having inspection door and base
- c) Grouting framework & foundation bolts including screen at bottom.
- d) Rain protection cowl with bird-screen (provided with roof – hood with limit switch).
- e) Vibration Isolators and all other accessories shall be provided as per Specification requirement.



**SPECIFIC TECHNICAL REQUIREMENT
FOR VENTILATION SYSTEM STAGE 2 (PART
III- AXIAL FAN)**

SECTION – I

REVISION 00

DATE: JUL 23

SUB SECTION: C1A

3.0 MATERIALS OF CONSTRUCTION

PI refer approved data sheet of Fan/Filter / Fans Schedule for details (attached at drawing section). Typical details are enlisted below

3.1 Axial Fan

- a) Casing: M.S. sheet – 3 mm thk for fan dia upto 750 mm, 5mm thick for fan dia of 750 mm and above as per IS:1079 / IS:2062 Gr. B
- b) Impeller: Cast Aluminum. (Alloy A-6M, IS-617)
- c) Hub: As per manufacturer std. (AL- LM6)
- d) Support frame and structure: M.S. of adequate thickness (Galvanized / painted) IS-2062 Gr. B.
- e) Neoprene rubber pads: As required.
- f) Coned inlet for wall exhausters / supply fans: MS (IS-2062 Gr.B)
- g) Supporting frame for mounting: As Required.
- h) Protective screen at inlet: Yes (Min 14 SWG Galvanized wire knitted in 1" square mesh).
- i) Rain Protection Cowl: Aluminum or hot dip galvanized after fabrication from MS.
- j) Mounting flange on casing: At inlet and outlet.
- k) Painting / protecting coating – All the MS parts shall be galvanized or protected with three coats of epoxy paint.

3.2 Roof Extractor Unit

- a) Casing/cowl/hood: (Spray / hot galvanized M.S. Sheet to IS: 2062 Gr.B (Short duct casing).
- b) Impeller: Cast Aluminum alloy to Al-LM 6, IS-617.
- c) Support frame and structure: M.S of adequate thickness (IS-2062 Gr.B).

3.3 Pre-Filter

- a) Filter Media: The filter media shall be of High-Density Poly Ethylene
- b) Efficiency: efficiency shall be about 90% down to 10-micron size particles when tested in accordance with BS: 6540 / ASHRAE – 52-76.
- c) Allowable pressure drop: Initial pressure drop – Not to exceed 6.0 mm WC at rated flow. Final pressure drops- Up to 10 mm WC. (Refer approved drawing for details)
- d) Frame Work 18 G GSS. Filter mounting frame shall be GI angle iron frame of adequate thickness.



**SPECIFIC TECHNICAL REQUIREMENT
FOR VENTILATION SYSTEM STAGE 2 (PART
III- AXIAL FAN)**

SECTION – I

REVISION 00

DATE: JUL 23

SUB SECTION: C1A

- e) Size – 610 x 610 mm (Approx.)

3.4 Fine Filter

- a) Filter Media: Synthetic non-woven for fresh air pressurization (MCC).
b) Efficiency:99.9% down to 5 micron
c) Allowable pressure drop: For HDPE (SNW) -6 mm WG during clean condition & 12 mm WG during dirty condition. (Refer approved drawing for details)
d) Frame Work: 18 G GSS.
e) Size -610 x 610 mm (Approx.)
f) The filter media shall be sandwiched in between two galvanized wire netting arrangement in a uniformly corrugated form to increase the surface area.
g) The filter shall be fixed in GI angle iron frames of adequate thickness suitable for long use in an industrial plant.

3.5 Motors

Refer approved motor data sheet and electrical section for details

4.0 CONTROL FOR AXIAL FANS

- a. The fans (both supply and exhaust fans) associated with mechanical ventilation system shall be operated locally. Local bush button station shall be provided by BHEL.

5.0 ACCEPTANCE TEST

The following measurements are a to be done prior to the acceptance of the plant by the client:

01. Air Quantity measurement to be taken at the Inlet Louver/Damper to establish the Equipment capacity in line with the specification requirement.
02. Power consumption to be measured for each equipment to establish the total Guaranteed Power consumption.
03. Measurement of Noise and Vibration for different Equipment

Bidder may refer approved PG/ Demonstration Test procedure attached at drawings section.

Instruments required for performance testing of various equipment / system of the package shall be arranged by the bidder at site. All instruments to be used for the tests at manufacturer's works/site shall be calibrated & arranged by the bidder. Any Electrical/C&I



**SPECIFIC TECHNICAL REQUIREMENT
FOR VENTILATION SYSTEM STAGE 2 (PART
III- AXIAL FAN)**

SECTION – I

REVISION 00

DATE: JUL 23

SUB SECTION: C1A

items and accessories like junction box, glands etc. shall be included by vendor in his scope.

Besides the system performance as above, bidder shall guarantee major technical parameters of various equipment's as per design basis / details furnished.

Note:

- 1) Any item/ equipment not specifically mentioned in this tender but required for complete erection, commissioning and successful PG test of the system shall be in bidder's scope of supply.



**SPECIFIC TECHNICAL REQUIREMENT
FOR VENTILATION SYSTEM STAGE 2 (PART
III- AXIAL FAN)**

SECTION – I

REVISION 00

DATE: JUL 23

SUB SECTION: C1A

8.0 GENERAL

- 8.1 Drawings/documents required for scope of supplies under this contract, if any, shall be subject to customer approval during detail engineering stage.
- 8.2 All drawings and documents shall be computer based.
- 8.3 All commissioning spares & consumables for trouble free operation shall be provided
- 8.4 Indicative list of makes is enclosed elsewhere in the specifications; however, this equipment's / items shall be subject to Customer & BHEL approval during detail engineering Stage.
- 8.5 Inserts or any support arrangement for fixing ducting, fans, piping etc. shall not be provided by BHEL Necessary supports may be taken from nearest structure / walls / roofs / floors etc. by Vendor.
- 8.6 Anchor fastener shall be used by vendor for fixing duct, pipes, fans etc. wherever applicable.
- 8.7 The tools and machine required for erection of equipment shall be arranged by Vendor.
- 8.8 Tools & tackles as required for regular maintenance shall be supplied by Vendor.
- 8.9 All openings required in brick wall for ducting, louvers and damper etc shall be provided by BHEL as mentioned in this spec. Grouting of fans along with anchor fasteners shall also be done by bidder.
- 8.10 The openings shall be finished properly. In case openings are done once the wall have been painted, repainting, to match with the existing wall paint shall also be done by the bidder. Sealing of duct/fan opening, grouting of foundation / foundation bolts etc. including special type of grouting like GPX2 etc. are in the scope of Ventilation system bidder.
- 8.11 All chemical, lubricants and consumables such as grease etc. required for pre-commissioning, commissioning, performance testing and till one year of operation after handing over shall be provided.
- 8.12 Each motor terminal box shall be provided with cable gland and lugs for the size and type of power and control cable of respective motor by the bidder.
- 8.13 In the event of any conflict between the requirements of two clauses of this specification documents or requirements of different codes and standards specified, the more stringent requirement as per the interpretation of the owner shall apply.



**SPECIFIC TECHNICAL REQUIREMENT
FOR VENTILATION SYSTEM STAGE 2 (PART
III- AXIAL FAN)**

SECTION – I

REVISION 00

DATE: JUL 23

SUB SECTION: C1A

9.0 EXCLUSIONS

Items of works listed below are excluded from scope of the Ventilation plant supplier.

9.1 Openings for axial and RE Fans.

However, dimensions of openings shall be strictly in accordance to the dimensions mentioned in this specification. Further, making good, the civil works after completion of erection of fans & its accessories for all the areas in the scope of this specification, where bidder's equipment's are going to be installed is in **bidder' scope**

9.2 For Electrical works, please refer Electrical Scope between BHEL and Vendor attached at Section C of tender specification.



**CUSTOMER SPECIFICATION
FOR VENTILATION SYSTEM
5X800 MW YADADRI TPS**

DOCUMENT NO.: PE-TS-417-554-A003

REVISION 00

DATE: JUL 23

**SECTION: I
SUB-SECTION: C 2
CUSTOMER SPECIFICATION**



**CUSTOMER SPECIFICATION
FOR VENTILATION SYSTEM
5X800 MW YADADRI TPS**

DOCUMENT NO.: PE-TS-417-554-A003

REVISION 00

DATE: JUL 2023

**SECTION: I
SUB-SECTION: C 2A
CUSTOMER SPECIFICATION-TECHNICAL REQUIREMENT**

- 3.01.01 Centrifugal Fan unit each complete with:
- a) Fan impeller (backward curved) with casing and supports and required steel frame / supporting structure, if any.
 - b) Electric drive motor of suitable rating considering at least 15% margin over the shaft power consumption.
 - c) Drive Pulleys, V-belt, belt guards, slide rails etc.
 - d) Dampers at fan outlet and flexible connection (Rubberized Canvas) with matching flanges.
 - e) Vibration isolators (rubber in shear type / neoprene rubber pad), foundation bolts and nuts.
 - f) Removable drain plug with the fan casing.
- NB: These Centrifugal fans also cover those required for Air Washer and Unitary Air Filtration Units.
- 3.01.02 Wall mounted axial flow fans each complete with:
- a) Fan impeller of cast alloy aluminium construction (LM-6 Grade) with blades of aerofoil design.
 - b) Electric drive motor of suitable rating considering at least 15% margin over the shaft power consumption including motor brackets.
 - c) Vibration Isolators.
 - d) Short duct (wherever required).
 - e) Coned inlet and grouting framework, if any.
 - f) Rain protection cowl with bird-screen made of GI, Foundation Bolts etc.
 - g) Dry filters including fixing framework for fan filter unit (wherever required).
 - h) Back draft dampers, wherever specified.
 - i) Protective wire netting inside the room, wherever required.
- N.B. For Toilets, Pantries, Stores requiring small capacity fans, Propeller type fans are acceptable.
- 3.01.03 Roof mounted axial flow fan (Roof Extractor) each complete with:
- a) Fan impeller of cast alloy aluminium construction (LM-6 Grade) with blades of aerofoil design.

- b) Electric drive motor of suitable rating considering at least 15% margin over the shaft power consumption including motor brackets.
- c) Vibration Isolators.
- d) Short duct mounting (if required) having inspection door and base with proper water sealing arrangement.
- e) Grouting Frame.
- f) Fan casing of heavy gauge sheet steel construction.
- g) Rain protection hood / cowl with bird screen and disconnection switch, foundation bolts etc.

3.01.04 Sheet metal type Air washer Units (AWU), each complete with:

- a) Air Intake Louver with bird screen of GI construction.
- b) Automatically cleanable water flooded stainless steel mesh filters cleaned by one bank of spray header with stainless steel water spray nozzles spraying water over the filter in the direction of air flow and one more bank of spray header with stainless steel water spray nozzles spraying water opposing the air flow.
- c) Two numbers Horizontally Split casing / back pull-out type Centrifugal pump sets (one running and one standby) complete with drive motor for circulation of water through the above spray header banks and provided with pot type suction strainer with bypass valves, inlet and outlet pressure gauges and filter back wash arrangement.
- d) Moisture eliminator sets of die-extruded PVC construction.
- e) Inspection doors with ladder and marine lights for different sections and cat walks as required.
- f) All valves, pipes with fittings, nuts and bolts, internal fittings and supports, including ball float valves for make-up water connection, quick-fill connection with valve, drain piping with valves up to the nearest drain point, and overflow connection with siphon.
- g) Double inlet Double width Centrifugal fan with electric drive motor, drive pulleys, v-belt, belt guards, cushy foot mountings, removable drain plug and other accessories as required. Both inside and outside surfaces of all parts of the fan shall be spray galvanized. The fan with drive motor shall be placed inside casing of AWU.

- 6.01.08 Proposal for repair or any similar operations involving the plugging, welding, boring or addition of metal to the original castings, shall be submitted to the Purchaser/Consulting Engineer and approval shall be received before any such work is carried out. Drawings showing details and locations of such modifications shall be submitted to the Purchaser/Consulting Engineer for his records.
- 6.01.09 The separate pieces of equipment shall be marked with unit number. The assembly drawing shall indicate part number of each equipment and unit number for easy correlation.
- 6.02.00 **Centrifugal and Axial Flow Fans**
- 6.02.01 ~~Centrifugal fans shall be SISW/DIDW as mentioned in the Specification. The design shall be in general end suction and upward/downward/inclined/horizontal discharge type as demanded by the system/installation need. All centrifugal fans are coupled to the drive motors with V-belts. Puller holes should be provided on fan impellers and pulleys for ease of extraction from fan/motor shaft. Fan/motor shafts should have threaded centre holes for fixing pushers and locking the impeller/pulley axially on fan/motor shaft.~~
- 6.02.02 All Roof extractors / supply fans and wall mounted exhaust/supply fans are of direct drive axial flow type. Roof extractors/supply fans shall have multi-bladed impeller with a short duct casing while wall mounted exhaust/supply fans shall have coned inlet suitable for free discharge of air.
- 6.02.03 The centrifugal fans and axial flow fans shall be capable of withstanding the stresses which may be experienced during normal operation under the condition which it is required for and during over speed test.
- 6.02.04 It is desirable that all centrifugal fans shall be designed to operate within 9% and 25% of system throttling line.
- 6.02.05 All the fan units shall be reasonably noise and vibration free in operation and therefore of reasonably low speed. RPM of axial flow fans shall be restricted within 1000 to reduce their noise level excepting roof extractors for which RPM shall be restricted to 1500. Outlet air velocity of all fans shall be restricted within 12 m/s.
- 6.02.06 Casing for centrifugal and axial flow fans shall be reasonably leak proof.
- 6.02.07 The first critical speed of the rotating assembly shall be at least 25% above the operating speed.
- 6.02.08 Fan wheels shall be statically and dynamically balanced according to AMCA standard. Fans of 5 HP and above sizes must be dynamically balanced.

6.02.09 Impeller

- a) ~~The blades of the centrifugal fan impeller for all units shall be backward curved unless otherwise specifically mentioned. The blades of the impeller shall be die formed aerofoil or laminar type. They shall have self-cleaning and non-overloading characteristics, and shall be welded to the back plate and shroud, if any. The fan wheel shall be statically and dynamically balanced.~~
- b) The axial flow fan impeller shall be cast in one piece, finished all over and are fully balanced both statically and dynamically. Finally the assembled rotor shall be dynamically balanced. All axial flow fan impeller shall consist of high efficiency aerofoil section blades. Puller holes should be provided on fan impellers and pulleys for ease of extraction from fan/motor shaft. Fan/motor shafts should have threaded centre hole for fixing pushers and locking the impeller/pulley axially on fan/motor shaft.

6.02.10 Casing

- a) ~~Centrifugal fan casing shall be of welded construction and provided with flanges on inlet and outlet sides for duct connection. Mounting legs welded to the casing shall be provided. Plummer blocks should preferably be not supported on the bracings/stiffeners of casing sidewalls.~~
- b) Axial flow fan casing for roof extractors/supply fans and their components shall be suitable for outdoor installation. The casings will be provided with flanges at inlet and outlet. All nuts & bolts associated with it shall be of zinc or cadmium plated with proper baking to remove hydrogen.

Easily removable inspection cover having galvanized fly nut shall be provided. The inspection covers shall be located such that the grease nipple for all bearings and also motor terminals are easily accessible through the cover. It is however, preferred that provisions will be there for greasing the fan bearings from outside the fan casing.

Suitable motor brackets as per manufacturer's standard for both roof and wall exhausters/supply fans shall be fitted. The brackets shall be designed to provide rigid mounting for motors.

6.02.11 Bearing

~~Centrifugal fan shaft shall be mounted on self-aligning, heavy-duty spherical roller bearing of adequate capacity and life. In no case the life of the bearings shall be less than 40,000 hours. Centrifugal fans for air washers installed in the T.G. Building, should have minimum bearing life of 100,000 hours. Bearings shall be grease lubricated and provided with fittings for lubrication from outside. The bearings shall be located in an easily accessible location to facilitate maintenance.~~

- 6.02.12 Roof extractors/wall mounted fans (if located on the exposed wall) shall be provided with hood for protection against rain and other contingencies. It must ensure no dripping of rainwater under any circumstances and will have low-pressure drop of air. The hoods shall be provided with a heavy gauge expanded metal bird screen. Axial flow fans should be fitted with protective screens from inside of room.
- Rain protection cowls will be designed to suit wall mounted exhaust/supply fans for protecting fans from rain. The cowls will be provided with bird screen of heavy gauge expanded metal netting.
- A typical sketch enclosed herewith shows arrangements for both roof extractors and rain protection cowl. Any other approved design for the hoods and cowls can be considered. Grouting frames for the cowls if required shall be included in the supply along with nuts and bolts.
- 6.02.13 Coned Inlet
- Wall mounted exhaust fans shall be provided with coned inlet made of M.S.
- 6.02.14 Inlet Screen
- Inlet screen shall be manufactured of min. 14 SWG galvanized wire knitted in 1" square mesh. Suitable flanges to protect the edges of the screen shall be provided.
- 6.02.15 Vibration Isolator
- Double deflection rubber in shear or rubber in compression type vibration isolators shall be provided with each centrifugal fan and each axial flow fan. Rubber bushes, washers, wherever needed for the vibration isolators shall be included in the supply. Sufficient number of such isolators shall be provided to ensure isolation of foundation from vibration of the equipment.
- 6.02.16 Fans For Special Application
- Fans for battery room, oil rooms and fuel stores shall be of spark proof construction. These axial flow type fans shall be bifurcated type construction with motor away from air stream. Motors for these fans shall be of flameproof construction.
- All fans for special application shall have all accessories as mentioned in the Specification.
- 6.02.17 Fan Drive
- a) Centrifugal fans shall be provided with V-belts and sheaves. All belts shall be sized with minimum 1.5 service factor. All V-belt drives shall be equipped with removable guards that do not impede the air flow to the fan inlet. There shall be a minimum of two belts per drive. All pulleys should have threaded puller holes for the ease of their extraction.

- b) All direct drive axial flow fan impellers shall be directly mounted on extended motor shaft.

6.02.18 Materials of Construction

The following materials shall be used for the construction of various parts:

a)	Centrifugal fan impeller	:	MS sheet (IS-2062) duly spray galvanized
b)	Axial flow fan impeller	:	Cast Aluminium Alloy (LM-6 Grade)
c)	Fan shaft	:	EN-8 as per BS-900 or equivalent
d)	Fan Scrawl	:	Heavy gauge M.S. (IS-2062)
e)	Fan supports, frames and	:	M.S. of adequate thickness (IS-Structure.- 2062)
f)	Coned inlet for wall mounted exhaust fans / Supply fans	:	M.S. (IS-2062)
g)	Dampers	:	M.S. of heavy gauge (IS-2062)
h)	Flexible connections for fan inlet and outlet	:	Plastic impregnated canvas with M.S. flange & cleats.
i)	“V” pulleys	:	G.I. multi-grooves (IS-210, Gr.20)
j)	“V” belts (Matched sets)	:	Reinforced rubber of appropriate section.
k)	Slide rails	:	C.I. or M.S.
l)	Connection pieces	:	Galvanized iron according to supplier's design.
m)	Bolts and Nuts	:	GI or cadmium plated unless otherwise specified.
n)	Rain protection cowls, hoods And casing for roof Exhausters/wall exhausters/ Supply fans	:	Aluminium or hot dipped galvanized after fabrication from M.S.
o)	Vibration isolating pad washers & bushes, if any.	:	Hard synthetic rubber of Hardness 40° shore.

8.00.00 TESTING & INSPECTION AT MANUFACTURER'S WORKS

8.01.00 The minimum quality assurance plan / test of various components of Ventilation System are listed below. However, Bidder shall conduct any other tests/ inspection required at the manufacturer's works to ensure that the equipment being supplied shall conform to the requirement of this specification and other applicable standards and codes. The detail of checks to be carried out in various stages of manufacturing and erection of various items of the system shall be submitted for Purchaser's approval in the form of quality assurance plans, field quality plans and procedures.

The items covered under the scope of supply and erection shall be of Purchaser's approved makes. Bidder has to ensure that the proposed bought out makes have proven track record and meet the qualification criteria mentioned elsewhere in the spec. Bidder is to submit the proposal of sub vendors of bought outs for Customer's approval along with their offer and no deviation with regard to approved sub vendors shall be acceptable to the Purchaser.

Material tests like physical, chemical test on various components being used shall be done as per relevant standards. Manufacturer's test certificates shall be submitted for all those tests for the review and approval of Purchaser.

All raw materials including the bought out shall be subjected to bidders inspection/ TC review as per their procedure / approved QAP for total compliance. The same shall not be limited to mechanical, physical, electrical, operational, aesthetic and functional checks, but shall confirm to the best engineering practice and strict adherence to the specifications and standards. Bidders QAP shall indicate all such tests and procedures.

The in process checks for various components shall confirm to the bidder's internal procedures which shall confirm to best manufacturing practices, national and international standards. QAP shall reflect all such tests/ standards and procedures in detail.

Internal test records / test reports shall be produced to Purchaser as required.

All panel mounted components/items like circuit breakers, switches, contactors, relays, push buttons, isolators, fuses, terminal blocks etc. shall be type and routine tested as per relevant IS/ international standards including special tests as applicable.

Type test certificates for Degree of Protection (of various items as applicable) as per the required degree specified elsewhere in the specification shall be submitted for Purchaser's review and approval.

Further to verify compliance to degree of protection on routine basis, following shall be carried out:

1. For IP-5X - It shall not be possible to insert a thin sheet of paper under gaskets and through enclosure joints.

2. For IP-4X - It shall not be possible to insert a one mm dia steel wire in to the enclosure from any direction without force.

8.02.00 Routine Tests

8.02.01 Centrifugal Fan

- a. 20% DPT of welding on fan hub, blades, casing and impeller as applicable.
- b. UT of fan shaft (if dia. \geq 50 mm) shall be carried out.
- c. 100% DPT of the fan shaft after machining shall be carried out.
- d. All rotating parts shall be statically & dynamically balanced as per IS 1940 Gr. 6.3 or better as applicable.
- e. All centrifugal fans shall be subjected to free run test to check the temperature rise, noise, vibration, current drawn during testing.
- f. Fans shall be performance tested with job motor (if required) as per relevant IS for airflow, static pressure, speed, efficiency, power consumption, noise and vibration.

8.02.02 Axial Flow Fan

- a. Acceptance tests and routine test shall be carried out as per IS: 3588.
- b. Dynamic balancing of the rotating part shall be carried out as per relevant standards.
- c. NDT of the fans blade/impeller shall be carried out as per relevant standard as required.
- d. Complete fan shall be performance tested with job motor (if required) as per relevant IS for airflow, static pressure, speed, efficiency, power consumption, noise and vibration.

8.02.03 Centrifugal Pump

- a. Non-destructive examination as follows:
 - i. Impeller/wearing ring/shaft sleeve/Casing/diffuser: MPI/DPT.
 - ii. Shaft, Couplings and other active components: UT (If shaft dia. \geq 50 mm) and DPT.
 - iii. Fabricated Pump components: DPT on welds.
- b. Hydrostatic test at two times the bowl discharge pressures at rated capacity or 1.5 times the shut off head whichever is greater.
- c. Dynamic balancing of assembled rotor to grade 6.3 or better as per ISO-1940.

- d. Performance test with job motor as per Hydraulic Institute Standards over entire operating range at rated speed, including vibration and noise measurement.
- e. Strip test after performance test (if required).
- 8.02.04 Air Distribution System & Air Filter
- a. Functional test of fire damper along with actuator shall be done.
- b. Filters shall be tested for pressure drop, efficiency and dust holding capacity and test certificates shall be submitted for review.
- c. All ductwork shall be carefully examined to determine their performance with the specification with respect of dimensions, materials, marking, workmanship and other requirement.
- d. After completion, all main ducting shall be checked for air leakage/tightness by smoke test method for leakages (at site). Leakages if any shall be made good by bidder.
- 8.02.05 Pipe and Fitting
- a. All pipes shall be hydrostatic pressure tested (UT/ECT are allowed as alternative) at tube mill as per relevant Std.
- b. All mother pipes used for fittings shall be subjected to hydraulic or ultrasonic test at tube mill.
- c. Non-destructive examination of welds shall be carried out in accordance with the relevant design/manufacturing codes.
- d. All welds shall be subjected to a visual examination and DPT.
- 8.02.06 Valve
- a. Hydraulic pressure tests shall be carried out on each valve to check body and bonnet strength. Seat leakage shall also be carried out as per approved drg. /data sheet. Check valve shall also be tested for leak tightness test at 25% of specified seat test pressure.
- b. Functional and dimensional testing and wear travel, seat contacts, smooth opening & closing shall be carried out on each valve.
- 8.02.07 Insulation
- a. Insulation material shall be tested for all mandatory tests as per relevant standards/ specification.
- b. Thermal conductivity test (only for thermal insulation) shall be done once in six months for the insulation material manufactured during six

months period for the same density, outer dia. and thickness of material as per IS: 3346 or equivalent standard. However if such tests have been carried out by the bidder on similar item which is not older than six months in a third party laboratory, test reports shall be submitted for review.

8.02.08 Air Washer Unit

- a. Dimensional check shall be carried out after a complete assembly as per the approved drawing/data sheet.
- b. Each component of the AWU & UAF shall be tested separately as per the inspection requirement mentioned herein above and relevant standard.
- c. Performance and functional test after a complete assembly shall be carried out with job motor at site if supplied in knock down condition.

8.02.09 Electric Motor

Every motor shall be routine tested as per IS: 325 to the extent necessary to establish that it is identical to the type tested motor.

8.02.10 Local Starter cum Control Panel / Local Starter Panel

- a. Operation under simulated service condition to ensure accuracy of wiring, correctness of control scheme and proper functioning of equipment.
- b. All wiring and current carrying parts shall be subjected to HV/IR test as applicable.
- c. Primary current and voltage shall be applied to all instrument transformers.
- d. Routine tests shall be carried out on all equipment such as instrument transformers, meters, contactors, switch fuse unit etc.
- e. The tests shall include wiring continuity tests, insulation tests, and functional tests to ensure operation of the control / protection / metering of individual equipment.
- f. All switches, meters, and other devices shall be tested and calibrated in accordance with relevant IS standards.
- g. Dimensional checks, bill of material check for quantity & make, painting checks shall also be carried out.

8.02.11 Cable Tray and Galvanizing Structure (if applicable)

Material check, Dimensional Check, Zinc coating thickness as per IS: 3203, IS: 4759 and Mass of zinc coating as per IS: 4759 & IS: 6749 including Adhesion

test and Uniformity of Zinc coating as per relevant IS shall be conducted on cable tray and accessories.

8.02.12 Gauges, Switches, Instruments, etc.

Accuracy, calibration, repeatability, material, dimension, functional tests and other checks as applicable shall be checked.

8.02.13 Painting

Painting of all surfaces shall be checked for shade, surface finish, uniformity, coating thickness (DFT) and adhesion test/peel off test.

9.00.00 **FIELD TEST**

9.01.00 **Type Tests**

Bidder should have performed the applicable type tests as per the IS / applicable standards on various components of each type and rating. Reports not older than five years shall be submitted to this effect. All such type test reports shall be subjected to the approval of Purchaser. In case the bidder has to carry out these type tests, all such tests shall be done at bidder's risk and cost within the schedule specified herein. No deviation in this regard is acceptable.

9.02.00 **Field Test**

Overall performance of the ventilation system shall be tested after complete installation at site. This test shall be carried out to determine whether the plant meets the performance requirements specified here in and shall include measurements of all parameters under various outside conditions and establishment of correct supply of equipment. All testing and calibrating instruments required for this purpose shall be supplied by the contractor.

10.00.00 **PERFORMANCE GUARANTEE, TOLERANCE, PENALTY AND TEST RECORD**

10.01.00 The Tenderer shall have to guarantee the performance of individual equipment. The Tenderer shall also guarantee maintenance of the inside conditions and the minimum air changes as indicated under "design criteria".

10.02.00 The test shall be conducted at the manufacturer's works / site in accordance with the specification and if the shop / site performance tests indicate the failure of the guaranteed performance for the equipment concerned, it would be necessary for the manufacturer to make good the deficiency at its own cost by incorporating the necessary modification, alteration and replacement.

10.03.00 The additional test required to show the effect of such alteration shall be performed by the manufacturer at no expense to the purchaser.

10.04.00 **TEST RECORDS**

The certificates and records of all tests shall be submitted to the purchaser / Consultant for approval. The manufacturer shall maintain records of all tests required in the specification during manufacturing, erection and commissioning. A list of records shall be submitted to the purchaser on completion of the job. The purchaser shall be able to obtain certified copies of such records at any time.

11.00.00 **SPECIAL CLEANING, PROTECTION & PAINTING**

11.01.00 Internal surface of all parts shall be cleaned to remove loose scales and dirt. The external surface of the motor and end-shield shall be sand blasted to remove all rusts, scale etc. All sharp edges shall also be removed. Welding rods, studs & other foreign objects shall be removed prior to final assembly. Excess oil and grease shall be removed by wiping.

11.02.00 All shop finished parts shall be painted with two (2) coats of rust preventing paint. One (1) coat of synthetic enamel final paint shall be applied over and above the rust proof paint before despatch of material.

11.03.00 All surfaces coming in contact with corrosive fumes / gases during exhaust ventilation system, e.g., that in the battery room shall be painted with chlorinated rubber paint or suitable epoxy paint.

11.04.00 All equipment shall be boxed / crated or otherwise protected for shipment. Dry nitrogen desiccant and other protections shall be provided as may be necessary.

12.00.00 **DOCUMENTS, DATA TO BE FURNISHED WITH TENDER PROPOSAL**

Besides submitting the enclosed Technical Proposal Particulars Sheets duly filled in, the proposal shall also include the following drawings, curves and information wherever applicable:

12.01.00 Preliminary equipment layout drawings for Air Washer and UAF units, as well as preliminary ducting layout drawing.

12.02.00 Characteristic curves of each type of centrifugal and axial flow fans.

12.03.00 Characteristic curve of each pump.

12.04.00 Descriptive and illustrative literature / catalogues / leaflets on each of the equipment and components offered.

12.05.00 Sectional drawings for air diffusers and grilles, as applicable.

12.06.00 An experience list about supply of similar plant and equipment. The list shall indicate the salient technical parameters in each case, the status of execution and the scope of approx. value of the work undertaken by the bidder.

- 12.07.00 A comprehensive write-up and / or brochure on details of manufacturing and testing facilities in the shop of the manufacturer.
- 12.08.00 Any other relevant data and particulars as needed.
- 12.09.00 Guaranteed motor input power requirement for each and every equipment.
- 13.00.00 **POST AWARD DOCUMENTS, DATA TO BE FURNISHED**
- 13.01.00 Particulars of drawings, data and documents
- 13.01.01 Design Calculation supporting sizing of Ventilation equipment.
- 13.01.02 Equipment layout and sectional drawings of
- a. Air Washer Unit.
 - b. UAF Unit.
- 13.01.03 Schematic flow and instrumentation diagram of the complete system indicating the limits of supply and erection.
- 13.01.04 Ducting layout drawing including sectional views indicating the details of duct sizes, duct joints, duct insulation, duct supports, diffusers, grilles, dampers etc for various floors of Power House Building, ESP, AHP & CHP Control Building and other auxiliary buildings, as applicable.
- 13.01.05 Layout drawings showing the roots of water pipe line with details of hangers, supports etc.
- 13.01.06 Outline drawings incorporating all principal dimensions, civil foundation drawings and weight etc. and also sectional drawings incorporating data of material of construction wherever applicable for following equipment:
- a. Air Washer Units
 - b. UAF Units
 - c. Centrifugal Air Blower with the Drive Motors
 - d. Centrifugal Pump sets with Drive Motors for circulation of water
 - e. Fan Filter Units, Supply Fans and Exhaust Fans with drive Motors
 - f. Roof Extractor fans with Drive Motors
 - g. Supply Air Grilles / Diffusers
 - h. Fire Dampers
 - i. Back Draft Dampers
- 13.01.07 Technical Catalogues and data sheet for each Equipment and instrument.
- 13.01.08 Drawings and data sheets for Dry Panel Type Filters.
- 13.01.09 Location details of all wall mounted type Axial Flow Fans.

VOLUME: IIID

SECTION-II

**TECHNICAL SPECIFICATION
FOR
VENTILATION SYSTEM**

- test and Uniformity of Zinc coating as per relevant IS shall be conducted on cable tray and accessories.
- 8.02.12 Gauges, Switches, Instruments, etc.
Accuracy, calibration, repeatability, material, dimension, functional tests and other checks as applicable shall be checked.
- 8.02.13 Painting
Painting of all surfaces shall be checked for shade, surface finish, uniformity, coating thickness (DFT) and adhesion test/peel off test.
- 9.00.00 **FIELD TEST**
- 9.01.00 **Type Tests**
Bidder should have performed the applicable type tests as per the IS / applicable standards on various components of each type and rating. Reports not older than five years shall be submitted to this effect. All such type test reports shall be subjected to the approval of Purchaser. In case the bidder has to carry out these type tests, all such tests shall be done at bidder's risk and cost within the schedule specified herein. No deviation in this regard is acceptable.
- 9.02.00 **Field Test**
Overall performance of the ventilation system shall be tested after complete installation at site. This test shall be carried out to determine whether the plant meets the performance requirements specified here in and shall include measurements of all parameters under various outside conditions and establishment of correct supply of equipment. All testing and calibrating instruments required for this purpose shall be supplied by the contractor.
- 10.00.00 **PERFORMANCE GUARANTEE, TOLERANCE, PENALTY AND TEST RECORD**
- 10.01.00 The Tenderer shall have to guarantee the performance of individual equipment. The Tenderer shall also guarantee maintenance of the inside conditions and the minimum air changes as indicated under "design criteria".
- 10.02.00 The test shall be conducted at the manufacturer's works / site in accordance with the specification and if the shop / site performance tests indicate the failure of the guaranteed performance for the equipment concerned, it would be necessary for the manufacturer to make good the deficiency at its own cost by incorporating the necessary modification, alteration and replacement.
- 10.03.00 The additional test required to show the effect of such alteration shall be performed by the manufacturer at no expense to the purchaser.
- 10.04.00 **TEST RECORDS**



**CUSTOMER SPECIFICATION
FOR VENTILATION SYSTEM
5X800 MW YADADRI TPS**

DOCUMENT NO.: PE-TS-417-554-A003

REVISION 00

DATE: JUL 2023

**SECTION: I
SUB-SECTION: C 2B
CUSTOMER SPECIFICATION-PROJECT SPECIFIC GENERAL
REQUIREMENT**

VOLUME : X

SECTION - I

PERFORMANCE GUARANTEES

CONTENT

CLAUSE NO.	DESCRIPTION
1.00.00	PERFORMANCE GUARANTEES, PERFORMANCE/ ACCEPTANCE TESTS & LIQUIDATED DAMAGES FOR SHORTFALL IN PERFORMANCE
2.00.00	START-UP, INITIAL OPERATION, RELIABILITY RUN AND PERFORMANCE TESTS
3.00.00	SCHEDULE OF GUARANTEES WHICH ATTRACT LIQUIDATED DAMAGES [CATEGORY-A]
4.00.00	SCHEDULE OF GUARANTEES WHICH DO NOT ATTRACT LIQUIDATED DAMAGES [CATEGORY-B]

VOLUME : X**SECTION-I****PERFORMANCE GUARANTEES****1.00.00 PERFORMANCE GUARANTEES, PERFORMANCE/ACCEPTANCE TESTS & LIQUIDATED DAMAGES FOR SHORTFALL IN PERFORMANCE**

1.01.00 The Bidder shall guarantee that the equipment offered shall meet the ratings and performance requirements stipulated for various equipment covered in this specification. The guarantees are categorised as:

- a) Those which attract liquidated damages, as listed below (Category-"A"). The Bidder shall furnish signed declarations in the manner prescribed in the bid proposal schedules for these guarantees.
- b) Those which do not attract liquidated damages, as listed below (Category-"B"). This guarantee list indicated in this section is not exhaustive and the Owner reserves the right to call upon the Bidder to demonstrate any parameter, operation, etc. of any equipment as specified and as required to meet the duty conditions.

1.02.00 The guaranteed parameters shall be without any tolerance values. The Bidder shall demonstrate all the guarantees covered in various volumes and sections of this specification during Performance/Acceptance test. In case during tests it is found that the equipment/system has failed to meet the guarantees, the Contractor shall carry out all necessary modification to make the equipment/system comply with guaranteed requirements. However, if the Contractor is not able to demonstrate the guarantees, even after the modifications within ninety (90) days of notification by the Owner, the Owner will at his discretion :

- i. reject the equipment and recover the payment already made or accept the equipment only after levying liquidated damages as identified in this section for those guarantees which are covered under category "A".

OR

- ii. reject the equipment and recover the payment already made or accept the equipment only after assessing and deducting from the contract price an amount equivalent to the deficiency of the equipment/system as assessed by the Owner, for those guarantees which are covered under Category-B.

1.03.00 All guaranteed parameters shall necessarily be quoted by the Bidder based on the established proven results obtained from similar units in successful operation. Evidence for this shall necessarily include the test codes used, acceptance test results, accuracies of various instruments used for the performance test, details of tolerances, if allowed, etc. While quoting the guaranteed parameters, the Bidder shall keep in view the requirements

specified in the specification especially regarding the reliability, operability and maintainability of the equipment proposed. The Owner reserves the right to evaluate the parameters quoted by the Bidder based on his experience and published material available.

1.04.00 The liquidated damages shall be calculated prorata for the fractional parts of the unit unless stated otherwise.

1.05.00 The turbine generator, boiler, auxiliaries, and all other plant equipment and system shall perform continuously without the noise level (individual or collectively) exceeding the values specified in respective equipment specification over the entire range of output and operating frequencies.

1.06.00 **Performance/Acceptance Tests**

1.06.01 The performance/acceptance tests for various equipment and systems shall be carried out as specified under the respective equipment specifications and those specified below shall be specifically applicable. All the guarantees shall be tested together as far as practicable.

1.06.02 In case of systems with stand-by equipment the liquidated damages for non-performance will be levied for normal operating number of equipment only. However, for this purpose all the equipment including standby equipment shall be tested and average values arrived at.

1.06.03 For instrument inaccuracies during PG Test, refer subsequent clauses of this section.

1.06.04 For Total Auxiliary Power Consumption, the transformers listed under the respective clauses, shall be taken together for purposes of guarantee and not individually.

2.00.00 **START-UP, INITIAL OPERATION, RELIABILITY RUN AND PERFORMANCE TESTS**

For the purpose of Taking over of the Plant, the following activities shall have to be completed successfully.

- i) Mechanical Completion
- ii) Preliminary Operation
- iii) Initial Operation
- iv) Reliability Operation
- v) Trial Operation
- vi) Performance Guarantee Tests

2.01.00 **Mechanical Completion**

- (a) Mechanical completion is defined as the state of readiness of works and completeness of Field Quality checks under the scope of contract to undergo the pre-commissioning checks, followed immediately thereafter by commissioning including preliminary operation, initial operation, reliability operation, performance tests including unit characteristics tests for functional or operational occupation of the

works.

- (b) Mechanical completion shall be deemed to occur when the contract erection/installation/construction and Field Quality check works are completed as per specifications for all equipment / systems including standby. It also include but not limited to the following:
 - (i) all installation/erection and Field Quality checks duly carried out and individual protocol viz. erection, FQA (Field Quality Assurance) and commissioning protocol to be signed.
 - (ii) all defects/deficiencies notified by the Purchaser during installation/erection rectified to the satisfaction of Purchaser which, in the opinion of the Purchaser, will not affect the safe operability and maintainability of the works, and
 - (iii) the contract works, in the opinion of Purchaser, subject to sub-clause (ii) above, being fit, sound, safe and operable for undertaking the pre-commissioning checks, preliminary operation, initial operation, reliability operation and performance tests including unit characteristics tests followed by subsequent commercial operation without interruption for reason of defect/deficiency or unfulfilled obligations of the Contractor in the erection/installation work.

2.02.00

Specific Requirements of Mechanical Completion

- (a) Mechanical completion in different disciplines shall be determined based on the following characteristics, signifying the readiness of the works/plants and systems for undertaking the pre-commissioning checks and subsequent preliminary operation, initial operation, reliability operation and performance tests including unit characteristics tests as applicable to the contract works:
 - (i) All plant construction/installation in various disciplines, as detailed under (b) below and as applicable to the contract are completed including aesthetic and workmanship and safety aspects, with all installation/construction checks as per specification, relevant codes, standards and practices ensuring conformity to contract and meeting any applicable statutory requirements.
 - (ii) All contractual obligations up to the stage of completion of construction / installation are fulfilled to the satisfaction of the Purchaser.
- (b) All contract works or otherwise ready to be taken into service, or for functional or operational occupation save pre-commissioning/commissioning checks, preliminary operation, initial operation, reliability operation, performance tests, unit characteristics tests are to be carried out as per approved commissioning procedure submitted by the contractor including but not limited to the following:

- (i) Areas inclusive of all roads, accesses, structures, housings, platforms, walkways, stairs, ladders, safe approach to equipments, safety/ protective guards, covers, hand rails and such items of work are constructed as per specification and approved for use.
- (ii) Drains, sewers, waste disposal channels, vents, chutes, ducts and such works are constructed and connected to treatment and other disposal systems.
- (iii) Equipment and piping in different systems/disciplines with all appurtenances, auxiliaries and accessories along with supporting structures, hangers, mounts, etc., are erected/ installed, supported, anchored, aligned, grouted and adjusted for operating conditions.
- (iv) Electrical power supply, control, communication and lighting equipment along with control panels, control desks, switchgear, local starters and such accessories along with protective systems, interlocks and integral and auxiliary systems are permanently installed, aligned and adjusted, with megger, continuity and specified installation checks duly carried out.
- (v) Cables are laid, routed, supported, dressed, clamped, tagged, ferruled and terminated with clamp terminals designated and all continuity and megger checks duly carried out.
- (vi) Safety/relief valves are calibrated and set to operating conditions and tried out. All safety systems are installed, calibrated, checked and accepted.
- (vii) Plant identification numbers, colour codes, tags, nameplates are duly mounted / painted/affixed.
- (viii) All painting, lining and insulation works are completed with specified checks to the satisfaction of the Purchaser.

2.03.00 **Other Prerequisites for Mechanical Completion**

The Contractor shall also meet the following prerequisites for mechanical completion:

- (a) Submit a compilation of all reports of shop tests, material tests and various stage inspection establishing total compliance to contract specification in manufacturing items of supply of contract.
- (b) Submission of a certificate by the Contractor in a format agreed by the Purchaser that the contract works have been designed, selected, manufactured, furnished and installed under the full responsibility of the Contractor.
- (c) All erected plants, structures, equipment and systems are maintained and preserved in sound condition and are fit and sound to undertake

pre-commissioning checks and 'tests before commercial operation' for operational and functional occupation immediately thereafter.

- (d) All areas and constructed works are cleared daily upto the satisfaction of the Owner of all construction materials, temporary works, debris, rubbish water and all such impediments to render the contract works safe, sound and operable.
- (e) All safety features and safety equipment are functional.
- (f) Fire prevention and fire extinguishing system in all fire prone areas are to be made functional.
- (g) Any specific statutory approvals pre-requisite to commissioning of the plant are duly obtained.

2.04.00 **Preliminary Operation**

Preliminary operation shall mean all activities undertaken as part of commissioning after mechanical completion upto commencement of initial operation and shall include mechanical and electrical checkouts, calibration of instruments and protection devices, commissioning of sub/supporting systems covered under the contract.

2.05.00 **Initial Operation**

Initial operation shall include all operations undertaken as part of commissioning after completion of preliminary operation upto commencement of reliability operation. It shall be the first integral operation of the complete BOP integrated with Boiler, Turbine Generator package covered under the contract and shall include first light up / initial equipment rolling, equipment stretch-out, dry-out no-load / partial load /full loads runs for mechanical / electrical tryout and gathering of operational data, calibration, setting and commissioning of controls systems; and shutdown inspection and adjustment after running trails of the plant under the contract.

During initial operation each and every activity wise commissioning protocols are to be jointly signed by the Purchaser and Contractor commissioning team.

The auto loop control tuning shall continue upto the commencement of 72 hour full load operation of trial run.

The initial operations shall include operation of unit as a whole under normal operating conditions for twenty four (24) consecutive hours at the 100% TGMCR load or twelve (12) consecutive hours for two (2) consecutive days at the 100% TGMCR load unless otherwise agreed to by the Purchaser or restricted by system load conditions. The completion of initial operation will be certified in writing by the Purchaser.

2.06.00 **Reliability Operation**

- (a) After the initial operations, the plant shall be on reliability operation. During the reliability operation, the Contractor will be allowed to make

minor adjustments as may be necessary, provided that such adjustments do not interfere with or prevent the commercial use of the plant or result in significant reduction of output. The duration of the reliability operation of plant shall be spread over a period of thirty (30) days. The maximum number of interruption attributable to Contractor shall be of four (4) numbers each not exceeding four (4) hours duration. In case either the number of interruptions, attributable to the Contractor, exceeds four (4) or the duration of any of the four (4) interruptions exceeds four (4) hours the reliability test shall be repeated.

- (b) For the period of reliability operation, the time of actual operation shall be counted. In case the duration of actual continuous operation of any of the above modes is discontinued for reasons, which are not due to Contractor's fault or negligence, that particular test would be deemed to have satisfied the reliability operation test. However, should the test be discontinued due to Contractor fault, the test shall be restarted for that particular case.
- (c) Should any failure (other than of an entirely minor nature) due to or arising out of faulty design, materials, or workmanship (but not otherwise) occur in any item of the plant, sufficient to prevent commercial use of the plant, the reliability test period of thirty (30) days shall recommence for that item after the defect has been remedied by the manufacturer/Contractor. The onus of proving that any failure is not due to faulty design, materials and workmanship will lie with the Contractor.
- (d) A 'reliability operation' report comprising observations and recordings of various parameters measured in respect of the 'reliability operation' shall be prepared and submitted to the Purchaser. This report, besides recording the details of various observations during 'reliability operation' shall also include the dates of start and finish of the reliability operation and shall be signed by the representatives of both the parties. The report shall have recordings of all details of interruptions that occurred, adjustments made and any repairs carried out during the 'reliability operation'.

Also a punch list is to be prepared during the reliability test and the defects are to be rectified by the contractor before commencement of 72 hour operation at full load during trial operation.

- (e) Should any failure or interruption occur in any portion of the tests due to or arising from faulty design, materials, workmanship, omissions, incorrect erection, or inadequate instructions by the Contractor's supervisors, sufficient to prevent safe commercial use of the plant, the reliability operation test at the particular load shall be considered void and the reliability test shall recommence after the Contractor has remedied the cause of the defect.
- (f) During the reliability operation all the equipments, Raw/ DM water system and sub-systems, control loops, interlocks and protection including switchyard installations will be in service and change over to standby equipments are to be done on running condition of the unit.

- (g) The 'reliability operations' shall be considered successful, provided that each item of plant can meet the above requirements.
- (h) Upon the completion of 'reliability operations', as soon as practicable, or at such time as may be otherwise agreed to by the parties concerned, the Contractor shall notify in writing to the Purchaser that the Plant is ready for performance tests.

2.07.00

TRIAL OPERATION:

1. On completion of erection of any major items along with its auxiliaries, the same shall be thoroughly inspected by the Contractor together with the TSGENCO's Engineers for correctness and completeness and acceptability for pre-commissioning tests. Though the TSGENCO's Engineers associate themselves with such inspection, the responsibility for declaration for correctness, completeness and acceptability shall rest with the Contractor and the pre-commissioning tests and inspections shall be carried out after such declaration. The pre-commissioning tests to be performed at site as well as necessary documentation and formats for the protocols to be signed during and after the tests shall be prepared by the Contractor taking into account relevant Indian/International/ Manufacturers standard as applicable and finalized by the TSGENCO sufficiently in advance through mutual discussions. On conclusion of satisfactory pre-commissioning tests of each individual equipment, the trial operation of the unit shall start consistent with parameters of the technical specifications.
2. The duration of trial operation shall be for 14 days during which period the unit shall be run from half to full load or any other load cycle mutually agreed to during which period the unit shall run at full load for 72 hours continuously. However, if required, the Purchaser and the Contractor may mutually agree for economical load operation for 48 hours continuously. Any interruption caused by the Contractor up to 24 hours will not effect the period of 14 days indicated above. In case of such interruption occurring for more than 24 hours, the above period shall be extended correspondingly. During the above trial operation the standby auxiliary equipment shall also be run for a minimum period of more than 72 hours during which period the equipment shall run at its rated capacity for a minimum period of 24 hours. Further the above trial operation shall be carried out in full fledged manner with the associated instruments and controls. The unit is deemed to be commissioned on successful completion of the above trial operation.
3. A document shall be prepared on the results of trial operation. This document besides recording of the details of the various observations during the trial run will also include the date of start and finish of the trial operation and will be signed by the representative of both the parties. The document of the trial operation shall have log sheets and all adjustments, repairs, interruptions etc., shall be recorded therein. If any major adjustment is carried out which has been changed from the initial operation value, then the reason for it is to be furnished in the

report in detail.

The Purchaser and the Contractor will observe the plant overall reliability and shall test the equipment runback, rundown, auto start of equipments, CMC function and its reliability, complete automation of the plant system etc.

4. The readiness of the unit for the trial operation shall be intimated by written notice to the TSGENCO after mutual discussions. After receipt of such notice if the trial operation could not be performed or could not be completed due to any reasons not attributable to the Contractor and if the situation continues, the Contractor shall be absolved of the responsibility for the delay and the plant shall be deemed to have been taken over by the TSGENCO at the end of 60 days after the Contractor's notifications of readiness of the same.
5. The trial operation shall be carried out in compliance with relevant manufacturer's standards and/or relevant Indian/International standards and manufacturer's operation directions before starting them.
6. Defects which are minor in nature and do not endanger the safe operation of the plant, shall not be considered as reasons for not taking over the plant by the TSGENCO. These defects shall be listed in the above mentioned documents and shall be rectified by the Contractor in accordance with the agreement made in this respect.

2.08.00 Performance Tests

- (a) PG test notification to be given by the contractor to the purchaser after COD. The performance tests shall be conducted at site on all major systems by the Contractor. The Contractor's commissioning Engineers shall make the entire plant ready for such tests and assist the Purchaser in operation during the tests. The test shall be commenced after the 'Plant/Equipment' has attained stable operation at the end of 'reliability operation'. The date of commencement of the performance tests shall be as soon as practicable on completion of the 'reliability operation' or as may be mutually agreed upon between the Contractor and Purchaser.

Final trial operation shall be carried out for a period of seventy two (72) hours at 100% TGMCR before 'taking over'.

- (b) **Independent Inspector**

The Purchaser reserves his right to appoint an independent inspector at his own cost as his representative to discuss the test programme, to approve the instrumentation, to witness the tests and to analyze the test results.

- (c) The tests shall be binding on both the parties of the contract to determine compliance of the 'plant'/'equipment' with the performance

guarantees.

- (d) The performance tests shall be carried out to prove the guarantees. The purpose of the performance tests is to check whether the plant meets the guaranteed performances.
- (e) The performance test procedure, the instrumentation to be installed, the instrument accuracy classes, including the definition of the calculation method to be used, the areas of responsibility and the items which specifically require preparation and agreement shall be submitted by the Contractor for review and approval during detail engineering phase. The schematics identifying the guarantee test instrumentation shall be submitted along with procedure. It shall be ensured that necessary test points and spool pieces are installed during the detail-engineering phase and also identified in process and instrumentation drawings. Code of the PG test is to be fixed up during detail engineering stage. The Contractor shall furnish detail test programme during detail engineering stage.
- (f) The performance test instruments shall be of precision type with instrument accuracy limits as required and defined in the applicable performance test codes such that measurement uncertainty does not exceed the values agreed to by the Contractor in the Schedule of Performance Guarantees.
- (g) All test instrumentation for the performance tests as required shall be supplied by the Contractor on loan basis. All costs associated with the supply, calibration, installation and return of the test instrumentation are deemed to have been included in the contract price. The test shall be in accordance with those specified or as per agreed performance test codes. Batch calibration shall not be accepted.
- (h) Any special equipment, tools and tackle required for successful completion of the performance tests shall be provided by the Contractor.
- (i) It is Contractor's responsibility to co-ordinate for carrying out the performance tests. The duration of the test shall be in accordance with the agreed test codes. All other tests to prove the guarantees as indicated in the Contractor's offer shall also be conducted.
- (j) The plant parameters during the performance test shall be adjusted as far as practicable to the guaranteed performance test conditions. The tests shall be conducted to provide guaranteed parameters as defined in the contract.
- (k) Category-B tests are to be completed before Category-A PG test. Protocols are to be signed jointly by the Purchaser and Contractor for each Category-B test.

(l) **Reporting of Test Results**

- (a) Within two weeks after the conclusion of the performance test,

the Contractor shall submit ten (10) copies of test reports to the Purchaser stating whether the plant passed or failed such test(s), accompanied by sufficient test data and calculations to demonstrate the level of performance attained with respect to each of the tested parameters.

- (b) The report(s) shall include as a minimum, the following:-
- (i) Scope
 - (ii) Various guaranteed parameters & tests as per the contract.
 - (iii) Codes/standards used
 - (iv) . Description of the test procedures
 - (v) Full schematic diagrams with indication of test instruments locations and identification tags of same.
 - (vi) Instrumentation details and calibration.
 - (vii) Duration of test, frequency of readings and number of test runs
 - (viii) Test logs and summary of test readings used for performance calculations.
 - (ix) Full set of correction curves.
 - (x) Computation of test results.
 - (xi) Sample calculation
 - (xii) Performance calculation
 - (xiii) Computations to prove measurement uncertainty is within acceptable limits.
 - (xiv) Acceptance criteria
 - (xv) Any other information required for conducting the test
 - (xvi) Conclusions of performance tests.
- (m) Within fifteen (15) days of receipt of such test report(s), the Purchaser shall submit a notice to the Contractor stating either:-
- (i) That Purchaser concurs with the information provided in the test report(s), or
 - (ii) That Purchaser disputes some or all of the information provided

in the Contractor's test report(s), the areas being disputed, and the levels of performance being disputed.

- (n) If Purchaser concurs with the information in the Contractor's test report(s), the Purchaser shall, within fifteen (15) days of receipt of the test report, provide a written notice to the Contractor accepting the results of the tests.
- (o) If Purchaser disputes any or all of the results contained in the Contractor's test report(s), the Contractor and Purchaser shall meet within fifteen (15) days of the receipt of the Purchaser notice at a mutually acceptable location to review and discuss the dispute.

All the category-B test results are to be computed and to be submitted along with the PG test report for detail study by the Purchaser.

2.08.00 **Notice of Tests**

The Contractor shall issue 21 days notice to the Purchaser of the date after which he will be ready to commence the tests and the Contractor shall commence the tests promptly thereafter.

2.09.00 **Delayed Tests**

- (a) If the tests could be carried out but are being unduly delayed by the Contractor, the Purchaser may by notice inform the Contractor to conduct the tests within 14 days after the receipt of such notice. The Contractor shall conduct the tests on such days within that period as the Contractor may fix and of which he shall issue notice to the Purchaser.
- (b) If the Contractor fails to conduct the tests within such notice period, the Purchaser may himself proceed with the tests. All tests so conducted by the Purchaser shall be at the risk and cost of the Contractor and the cost thereof shall be deducted from the contract price or charged to the Contractor. The tests shall then be deemed to have been conducted by the Contractor and the test results shall be binding on the Contractor.

(c) **Facilities for Tests on Completion**

Except where otherwise specified, the Contractor shall provide and bear costs for these items, as may be required to carry out the tests on completion.

(d) **Retesting**

If the plant fails to pass the test (which in the case of performance tests means not achieving the acceptable limits), the Purchaser may require such tests to be repeated on the same terms and conditions save that only reasonable notice of the date and time of such tests shall be required to be given by the Contractor to the Purchaser.

(e) **Disagreement as a Result of Tests**

If the Purchaser and the Contractor disagree on the interpretation of the test results, each shall give a statement of his views to other within 14 days after such disagreement arises. The statement shall be accompanied by all relevant evidence.

3.00.00

SCHEDULE OF GUARANTEES WHICH ATTRACT LIQUIDATED DAMAGES [CATEGORY-A]

Sl. No.	Plant/ System	Parameter for Performance Guarantee	Liquidated Damages
3.01.00	Plant		
3.01.01	Efficiency of steam generator	Efficiency of the steam generator at 100% & 80% TMCR while firing the Design coal at rated steam parameters, rated coal fineness and rated excess air. (Refer Note-1 for estimation of weightage factor.) Design coal shall be blended coal (50% imported coal + 50% indigenous coal).	As per Volume-I.
3.01.02	Steam generating capacity	Steam generating capacity in T/hr of steam at rated steam parameters at superheater outlet (with any combination of mills working) with the coal being fired from within the range specified.	As per Volume-I.
3.01.03	Turbine Cycle Heat rate	Turbine Cycle Heat rate in kcal/kWh under rated steam conditions, design condenser pressure with zero make up at 100% & 80% of rated load (Refer Note-1 for estimation of weightage factor.)	As per Volume-I.
3.01.04	Output	Continuous output (MW) of 100% TMCR at Generator terminals under rated steam conditions at Turbine Inlet (247 kg/cm ² (a), 565°C, 593°C) and CW temperature of 33°C with 0% make-up with excitation power deducted	As per Volume-I.
3.01.05	Condenser Pressure	Condenser pressure in mm Hg (abs) under VVO conditions, 3% make up, design CW temperature and CW flow.	As per Volume-I.

SI. No.	Plant/ System	Parameter for Performance Guarantee	Liquidated Damages
3.01.06	Total Auxiliary Power Consumption	The total auxiliary power consumption for all the auxiliaries of boiler, turbine Generator and turbine cycle equipments required for continuous unit operation at 100% and 80% of rated load under rated steam conditions and at design condenser pressure with 0% make-up. (Refer Note 1, 2, 3 & 4 for the basis of computation of Auxiliary power)	As per Volume-I.
3.01.07	Cooling Tower Cold Water Temperature	Cooling tower cold water at 100% TMCR under rated steam conditions and at design condenser pressure.	As per Volume-I.

Note :

1. The weightage factor shall be estimated considering the following:
 - a) 80% rating for 2000 hrs in a year,
 - b) 100% rating for 6300 hrs in a year.
2. For computation of Auxiliary Power, output measured at Generator terminals minus sent out power measured downstream of Generator Transformer, applicable Losses (No load loss + Load loss+ auxiliary loss for coolers) for Standby Transformers, Unit Transformers and Bus duct losses shall be considered.
3. The equipment for auxiliary power consumption to be considered by the bidder shall include the equipment as per Annexure-C of Volume-I as minimum.
4. Power consumption for Fire Pumps, Sump Pumps, Elevators, EOT Cranes shall not be considered in the Auxiliary Power consumption estimate.
5. Heat Rate of TG Cycle : Maximum 1850 Kcal/kwh with Steam Turbine driven BFP.
6. Steam Generator Efficiency : Not less than 85%
7. Auxiliary Power Consumption shall be limited to 6% with Steam Turbine driven BFP and NDCT.
8. Normal Availability of the Plant : 98% (2% forced outage)
9. Plant Reliability : Minimum 95%
10. The condenser pressure measurement while conducting the guarantee tests for CI Nos 3.01.03, 3.01.04 and 3.01.05 above shall be measured at 300 mm above the top row of condenser tubes.

4.00.00 SCHEDULE OF GUARANTEES WHICH DO NOT ATTRACT LIQUIDATED DAMAGES FOR VARIOUS EQUIPMENT WHICH INCLUDE BUT ARE NOT LIMITED TO THE FOLLOWING [CATEGORY-B]:**4.01.00 Steam Generator**

4.01.01 Capacity in T/hr of steam at rated steam parameters at superheater outlet (with any combination of mills working as per Owner's discretion) and the coal being fired within range specified, corresponding to 100% BMCR at 33°C CW temperature.

4.01.02 Efficiency in percentage at 100% & 80% TMCR and 27°C ambient air temperature and 60% RH with zero make-up, condenser vacuum of 77 mm Hg(a) or better while firing the Design coal at rated steam parameters at Superheater and Reheater outlet and rated excess air and with any combination of mills working as per Owner's discretion. Design coal shall be blended coal (50% imported coal + 50% indigenous coal).

4.01.03 Air heater air-in-leakage after 3000 hrs. of operation from taking over date. To be demonstrated.

4.01.04 NOx emission

NOx emission from the unit – shall not be more than 365 ppm or 750 mg/Nm³ (equivalent NO₂) at the ESP outlet at 6% excess oxygen.

4.01.05 Mill capacity at rated fineness.

4.01.06 Gas tightness efficiency of Guillotine dampers.

4.01.07 No fuel oil support shall be required above 30% of BMCR.

4.01.08 Performance characteristics of pumps, fans, etc. viz; capacity, head developed etc.

4.01.09 Capabilities of all drives.

4.01.10 Margins on fans. Through operation of single fan at a time.

4.01.11 Equal load sharing of pumps/fans while running in parallel shall be demonstrated.

4.01.12 Run back capabilities.

4.01.13 Ramp/sudden load change withstand capability.

4.01.14 Life of mill wear parts

4.01.15 Furnace Exit Gas Temperature

The Bidder shall demonstrate by direct measurements that the Furnace Exit Gas Temperature (FEGT) at the specified location does not exceed the

specified maximum temperature of BMCR. The test equipment to be used for this demonstration shall be latest, state of the art, to the approval of Owner.

4.01.16 Flue Gas Temperature

The Bidder shall also demonstrate that the flue gas temperature at the entry and exit of various boiler heating surfaces and also the variation across the cross section perpendicular to gas flow do not exceed the values considered for the pressure parts design.

4.01.17 Steam Temperature Imbalance

The Bidder shall guarantee and demonstrate that at SH and RH outlets (in case of more than one outlet) the temperature imbalance between the outlets does not exceed 10°C.

4.01.18 SH/RH Attemperation System

The Bidder shall guarantee and demonstrate that the spray water flow to SH attemperation system does not exceed the value considered for design (to be indicated in the bid) while maintaining the rated SH outlet steam temperature at BMCR. The Bidder shall also guarantee and demonstrate that the RH temperature is maintained at the rated value without any spray water requirement, for the secondary attemperation system, at all loads for which the specified RH steam temperature is required to be maintained at the rated value.

4.02.00 **Electrostatic Precipitator**

4.02.01 Pressure drop across the electrostatic precipitator.

4.02.02 Collection efficiency and outlet dust concentration shall be as per cl. no. 3.01.00 of Section-II in Volume-II-B.

4.03.00 **Turbine Generator**

4.03.01 Turbine Generator-Set Capability

The steam turbine generator unit shall be capable of delivering continuously at generator terminals the output as indicated by the Bidder in the following heat balances detailed out elsewhere with equipment specification submitted alongwith the bid.

- a) Output corresponding to top HP heaters out of operation.
- b) Output corresponding to all HP heaters out of operation.
- c) Output corresponding to VVO flow, at rated steam conditions with condenser CW temperature 33°C & condenser of vacuum 77 mm HgA or better with 0% make-up.
- d) Output corresponding to overpressure operation of the boiler-turbine-generator set, at rated main steam and hot reheat steam

temperature with condenser CW temperature corresponding to
Condenser vacuum of 77 mm HgA or better with zero percent make-up.

4.03.02 Operating Frequency Range

As per the stipulations of Cl. No. 7.06.00 Vol. II-C, Section-I.

4.03.03 Constant Pressure and Sliding Pressure Operation

The constant pressure operation and sliding pressure operation from 30% turbine MCR to VVO condition of the unit in conjunction with the steam generator, HP-LP bypass system and instrumentation & control system shall be demonstrated.

In sliding pressure mode of operation, during quick load increase the idle control valve (s) must respond rapidly to pick up 20% of operating load, so that immediate increase of boiler pressure is not required. The load response capability shall be demonstrated in steps of 5 %.

Change-over from constant pressure mode to sliding pressure mode and vice-versa shall also be demonstrated.

4.03.04 Start-up, Loading, Unloading and Shutdown Capabilities

Start-up, loading, unloading and shutdown characteristics and startup time and loading capabilities for the steam turbine generator and steam generator both operating as a unit for cold start conditions (greater than 36 hours shutdown), warm start conditions (between 8 and 36 hours shutdown) and hot start conditions (less than 8 hours shutdown) under constant pressure and variable pressure mode and suitability for cyclic operation as indicated by the Bidder in the offer and accepted by the Owner shall be demonstrated ensuring the parameters of vibration, differential expansion, etc.

4.03.05 Vacuum Pulling time

Vacuum pulling time from condenser at atmospheric pressure to rated vacuum compatible to start Steam Turbine

4.03.06 Sudden Total Loss of External Load

On occasions, the steam turbine generator system may experience sudden total loss of all external load. Under these conditions, the steam turbine generator unit shall not trip on overspeed but shall continue in operation under the control of its speed governor to supply power for the plant auxiliary load station transformers, while staying within the prescribed permissible limits of steam metal temperature mismatch, exhaust hood temperature, absolute and differential expansion, vibration and eccentricity acceptable to the Owner.

4.03.07 Capacity with Reduced Hydrogen Pressure

Generator shall be capable of operating at reduced capacity at reduced generator hydrogen pressure in accordance with values furnished by the Bidder in his proposal and accepted by the Owner.

- 4.03.08 HP/LP Bypass Capabilities
- i. HP/LP bypass capacity and capabilities under various modes of operation shall be demonstrated.
 - ii. Condenser performance with HP-LP Bypass operating at rated conditions.
- 4.03.09 Lube Oil Purification System - Capacity and Purity
- Lube oil purification system capacity and the purity of purified oil at the outlet of the centrifuge and the outlet of the polishing filter, shall be demonstrated. If purity check is not possible at site, this shall be carried out at Vendor's works.
- 4.03.10 Extraction and CRH NRVs
- Operation of the valves under turbine trip and high water level in the heaters, shall be demonstrated.
- 4.03.11 The performance of the condenser, i.e., the back pressure achieved at design CW flow and inlet temp. and cleanliness factors, VWO heat load shall be demonstrated.
- 4.03.12 Temp. of condensate at outlet of condenser shall not be less than saturation temp. corresponding to the condenser pressure at all loads.
- 4.03.13 Oxygen content in condensate at hot-well outlet shall not exceed the limit prescribed by HEI over the entire load range and shall be determined according to an internationally approved codes/standard.
- 4.03.14 When one half of the condenser is isolated, condenser capability shall be demonstrated to take at least 60% T.G. load under TMCR conditions.
- 4.04.00 **Deaerator**
- 4.04.01 The dissolved oxygen content in feed-water measured at deaerator outlet shall not exceed 0.005 cc/litre at all loads from no load to VWO condition with 3% cycle make-up with normal pressure and overpressure with incoming condensate presumed to be saturated with oxygen (without any chemical dosing).
- 4.04.02 Free carbon dioxide in deaerator effluent shall be non-traceable at all loads from zero to VWO with 3% cycle make-up with normal pressure according to ASTM standards.
- 4.05.00 **Power Cycle Pumps**
- Performance of each pump (flow, head, vibration, noise, parallel operation) to be demonstrated.
- 4.06.00 **Automatic On Line Turbine Testing (ATT) System**

Demonstrated without disturbing normal operation.

4.07.00 **Coal Handling Plant**

Refer Cl. No. 10.00.00 in Volume-IV-A.

4.08.00 **Water Treatment System**

Performance Guarantee of Chemical Feed System shall be in accordance with Cl. No. 8.04.00 in Section-IV, Volume-II-B of the EPC Bid Specification.

Performance Guarantee of Condensate Polishing System shall be in accordance with Cl. No. 8.04.00 in Section-VI, Volume-II-C of the EPC Bid Specification.

Performance Guarantee of River Water Pre-Treatment System shall be in accordance with Cl. No. 8.04.00 in Section-I, Volume-III-C of the EPC Bid Specification.

Performance Guarantee of Demineralisation System shall be in accordance with Cl. No. 8.04.00 in Section-II, Volume-III-C of the EPC Bid Specification.

Performance Guarantee of Circulating Water Treatment System shall be in accordance with Cl. No. 8.04.00 in Section-III, Volume-III-C of the EPC Bid Specification.

Performance Guarantee of Waste Water Treatment System shall be in accordance with Cl. No. 8.04.00 in Section-IV, Volume-III-C of the EPC Bid Specification.

4.09.00 **Instrumentation and Control**

The Bidder shall demonstrate that the Instrumentation and Control system meets all the functional/performance requirements, specified in technical specifications.

4.10.00 **Noise Level**

The Bidder shall demonstrate Noise Level of various plants/equipments/systems as per Clause no. 17.02.00 in Section-IV of Volume-II-A.

4.11.00 **Air Conditioning & Ventilation system**

The rating and performance figures of the AC & Ventilation system & equipment as indicated in the respective technical specification shall be guaranteed by the Bidder. In the event of any deficiencies in meeting the guarantees as indicated in the technical specification after conducting the performance test, the bidder shall put all his efforts to rectify the deficiencies or will replace the equipment / accessories to achieve the specified performance parameters within a reasonable time.

5 x 800 MW YADADRI TPS

SECTION IA
(GENERAL TECHNICAL REQUIREMENT)



BHARAT HEAVY ELECTRICALS LTD
POWER SECTOR PROJECT ENGINEERING MANAGEMENT
NOIDA-INDIA

GENERAL TECHNICAL REQUIREMENTS

components shall be employed in different pieces of equipment in order to optimize the spares inventory and utilization.

8.00.00 **MATERIALS**

8.01.00 In selecting materials of construction of equipment, the Contractor shall pay particular attention to the atmospheric conditions existing at the Site and the nature of material/fluid handled. Wherever deviations are taken in respect of materials specified, the reasons shall be spelt out clearly in the proposal.

All materials shall be new, and shall be of the quality most suited to the proposed application.

8.02.00 In as far as is possible; materials shall be in accordance with Indian or international standard specifications and shall be used in accordance with Indian or international codes of practice. Where such standards or codes of practice are not available sufficient information shall be provided to allow the Owner to assess the suitability of the material for the particular application.

All materials used shall have performed lengthy satisfactory service in similar or more arduous conditions to those proposed by the Contractor.

8.03.00 All parts which could deteriorate or corrode under the influence of the atmospheric, meteorological or soil conditions at the Site, or under the influence of the working conditions shall be suitably and effectively protected so that such deterioration or corrosion is a minimum over the life of the plant.

9.00.00 **LUBRICATION**

9.01.00 Provision shall be made for suitable efficient lubrication where necessary to ensure smooth operation free from undue wear.

9.02.00 Non ferrous capillary tubing shall be used throughout.

9.03.00 Gear boxes and oil baths shall be provided with filling and drain plugs, both of adequate size. An approved means of oil indication including level switches and temperature indication shall be provided.

9.04.00 All high speed gears shall be oil bath lubricated. Low speed gears shall be lubricated by means of soft grease. Removable and accessible drip pans shall be provided to collect lubricant which may drop from operating parts.

9.05.00 All lubrication points shall be conveniently situated for maintenance purposes. It must be possible to carry out lubrication from a gangway or landing and without the removal of guarding or having to insert the hand into it. Where accessibility to a bearing for oiling purposes would be difficult a method of remote lubrication shall be fitted.

9.06.00 The Contractor shall supply grease gun equipment suitable to service each type of nipple fitted.

10.00.00 **LUBRICANTS AND CONTROL FLUIDS**

10.01.00 The Contractor shall provide a detailed and comprehensive specification for all lubricating oils, greases and control fluids required for the entire plant. A sufficient supply of these shall be provided by the Contractor for initial commissioning, first fill and till COD of the unit.

10.02.00 The Contractor shall supply a detailed schedule giving the lubricant testing, cleaning and replacement procedures. All equipment and facilities necessary for the testing, cleaning and changing of lubricants and control fluids shall be provided. The Contractor shall endeavor to reduce the varieties and grades of required lubricants and control fluids to a minimum, matching them where possible to those already in use in the generating station in order to simplify procurement and minimise storage requirements. All lubricants and control fluids shall be of internationally recognised standards and shall be easily obtainable from a large number of Indian suppliers. Bidder shall also indicate the equivalent Indian Standard for the above for easy procurement in future.

10.03.00 No lubricant or control fluid shall have toxic or other harmful effects on personnel or on the environment.

11.00.00 **OPERATION AND MAINTENANCE**

11.01.00 The plant shall be designed and constructed so that operation and maintenance manpower requirements are minimised.

The design and layout shall facilitate inspection, cleaning, maintenance and repair. The importance of continuity of operation is second only to that of safety.

11.02.00 Spare parts for equipment shall be interchangeable with the original components and, so far as possible, be of common design and manufacture.

11.03.00 All similar standard components/parts of similar standard equipment provided shall be interchangeable with one another. Further identical equipments shall be provided for similar duties so that the same are interchangeable with one another in totality and component wise.

11.04.00 All heavy parts (500 Kg and above) must be provided with a convenient arrangement for slinging and handling during erection and overhaul. Any item of plant normally stripped or lifted during periods of maintenance and weighing one tonne or above, shall be clearly marked with its weight.

11.05.00 On completion of commissioning, a complete set of tools for the maintenance of the entire plant shall be provided by the Contractor. This shall include all necessary spanners, special wrenches, extraction equipment and any special tools reasonably required by the Engineer. Tools used during erection and commissioning shall not be accepted except with the specific approval of the Engineer.

11.06.00 All equipment and major valves should be provided with adequate maintenance approach and facility.

12.00.00 **PLANT LIFE AND MODE OF OPERATION**

The complete plant including all the equipment and systems individually and collectively shall be designed for continuous operation for an economic service life of thirty (30) years under the prevailing site conditions and for the type of duty intended.

The critical components of the Steam Generator, Turbine-Generator and Auxiliary equipment, the life of which is limited by time and temperature dependent mechanisms such as thermal stress, creep and low cycle fatigue, are to be designed considering expected (hot, warm and cold) start-up, shut-down and cyclic load variations.

The allowable stresses shall be reduced so that life expectancy to minimum 2,00,000 hours of operation can be achieved. The Bidder shall discuss this aspect in his technical proposal.

The unit would be operated on base load with cyclic load variation. The load variation is expected to be as per schedule depending on power demand.

The expected start-ups should be considered as minimum
(Based on HPT metal temperature)

Cold start-up (>72 hrs. shutdown)	:	6 per year
Warm start-up (between 10 to 72 hrs. of shutdown)	:	40 per year
Hot start-up (less than 10 hrs. shutdown)	:	160 per year

13.00.00 **PACKAGING & MARKING**

All the equipment shall be suitably protected, coated, covered or boxed and crated to prevent damage or deterioration during transit, handling and storage at site till the time of erection. While packing all the materials, the limitations from the point of view of availability of railway wagon sizes in India should be taken account of. The details of various wagons normally available with Indian Railways for transportation of heavy equipment shall be considered by the Bidder. The Contractor shall be responsible for all loss or damage during transportation, handling and storage due to improper packing.

As per the information available, the dimensions of OD consignment for transportation of the equipment by rail (if any equipment to be handled through rail transportation) are as below :

- a) Width of the Package : 3.2 Meters
(from centre-line of rails
- 1.6 metres on both sides)
- b) Height of the package from rail top : 4.47 Meters

The above indicates the dimensions which can be normally transported on the

wagons without infringement of the "moving gauge". This is however not indicative of the consignment which can be carried out with infringement of "moving gauge" duly authorised and approved by the Indian Railways. There may be difference between the "moving gauge" and the "fixed structure gauge" and consignments infringing the "moving gauge" can be moved after investigation regarding possible infringement with the fixed structures. As the critical fixed structures in each route are different, consignments infringing moving dimensions have to be individually investigated to select a route and also determine the restrictions under which such movement is to be carried out. Such routes selected or other mode of transport envisaged is to be clearly brought out in the proposal wherever transport of over dimensional equipment is involved.

Bidder to consider unloading of material delivered through rail transportation, at near by railway station/ site unloading siding. The subsequent transportation up to project work place shall be considered by road only. All unloading and handling equipment both at railway station siding and at project site shall be arranged by the Bidder. Necessary arrangement to be organized with the railway authority for such purpose shall also be under the scope of services of the Bidder. Bidder may consider entire material delivered up to site through rail transportation only.

The identification marking indicating the name and address of the consignee shall be clearly marked in indelible ink on two opposite sides and top of each of the packages. In addition the Contractor shall include in the marking gross and net weight, outer dimension and cubic measurement. Each package shall be accompanied by a packing note (in weather proof paper) quoting specifically the name of the Contractor, the number and date of contract and names of the office placing the contract, nomenclature of contents and Bill of Material.

For imported equipment and material, suitable port facilities may be used in which case material may be transported from the port by tractor-trailer. Bidder may consider this aspect.

14.00.00 **PROTECTION**

Equipment having antifriction or sleeve bearings shall be protected by weather-tight enclosures. Coated surfaces shall be protected against impact, abrasion, discoloration and other damages. Surfaces that are damaged shall be repainted.

Electrical equipment, controls and insulations shall be protected against moisture and water damages. All external gasket surfaces and flange faces, couplings, rotating equipment shafts, bearings and like items shall be thoroughly cleaned and coated with rust preventive compound as specified above and protected with suitable wood, metal or other substantial type covering to ensure their full protection. All exposed threaded parts shall be greased and protected with metallic or other substantial type protectors.

All piping, tubing and conduit connections on equipment and other equipment openings shall be closed with rough usage covers or plugs. Female threaded openings shall be closed with rough usage covers or forged steel plugs. The closures shall be taped to seal the interior of the equipment. Open ends of

pipng, tubing and conduit shall be sealed and taped.

Returnable containers and special shipping devices shall be returned by the manufacturer's field representative at the Contractor's expense.

15.00.00 **ENVIRONMENT PROTECTION AND NOISE LEVEL REQUIREMENT**

15.01.00 **Environment Protection**

The plant shall be designed for installation and operation in harmony with the surrounding environment and all measures of pollution control shall be ensured by the Bidder to restrict pollution from the liquid effluent and stack emission within the limits as given below with due consideration of Environment (Protection) Rules 1986 as amended till date.

In case the Ministry of Environment & Forest stipulate any other conditions not specified hereunder while clearing the project shall be complied with the plant by the contractor.

15.01.01 For Liquid Effluent

- a) Provision laid down in schedule-I for Thermal Power Plants and also in Schedule-VI. General Standards for discharge of Environmental pollutants Part-A : Effects of Environmental (protection) Rules 1986, as amended till date.
- b) Any specific requirement of State Pollution Authorities over and above the above stipulation.

15.01.02 For Air Emission

- a) Suspended Particulate Matter i.e. dust burden at chimney outlet - Maximum 50 mg/Nm³ (with worst coal and one field out at TMCR).
- b) NO_x - 365 ppm Max. or 750 mg/Nm³ (Equivalent NO₂).
- c) SO₂ - Concentration based standard 2000 mg/Nm³. Load based standard 0.2 metric tonne /MWe/day (for first 500 MW and 0.1 metric tonne/MWe/day for rest of the capacity above 500 MW)

In absence of Indian Standard for emission from power plants as on date, for certain gaseous effluents, the internationally accepted World Bank Standard is to be followed. Indian Standard for emission of power plants are under formulation. Should this standard is published before finalisation of the contract, the bidder has to comply the more stringent of the above norm or the new Indian Standard.

The bidder shall include in his scope all necessary equipment and measuring instruments to comply with above requirements. Location and accessibility of the instruments shall be properly coordinated.

DOCUMENT DISTRIBUTION

DISTRIBUTION SCHEDULE

S. No	Description	TSGENCO								CONSULTANT			Equipment Vendor	Remarks
		Director Projects	Director Technical	CE/Civil Thermal Projects Hyd.	CE/ TPC-I, Hyd	CE/ O&M/ KTPS	SE/ Civil KTPS	SE/E&M / KTPS	DE Constr. KTPS	Kolkata	HYD	KTPS		
A	Letter Of Intent or Contract Documents	1	1	1	S	1	2	2	1	1	1	1	2	
B	Vendor Drawings													
1.	Preliminary	1	1	1	2	1	1	2	2	12	1	-	S	
2.	Return preliminary with comments	-	-	1	2	1	1	1	1	S	1	-	1	
3.	Final and any revision thereof													
	a. Civil	1	1	6+1T	1	1	6+1T	1	-	2+1T	1	1	S	
	b. E&M	1	1	1	6+1T	1	1	6+1T	1	2+1T	1	1	S	
C.	Design Drawings													
1.	Preliminary													
	a. Civil	1	1	2	1	1	2	1	1	4	1	1	S	
	b. E&M	1	1	1	2	1	1	2	1	4	1	1	S	
2.	Released for construction													
	a. Civil	1	1	2	1	1	6	1	1	1	1	2	S	
	b. E&M	1	1	1	1	2	1	6	1	1	1	2	S	
3.	Return marked 'As built'													
	a. Civil	-	-	1	-	-	1	-	-	1	1	S	1	
	b. E&M	-	-	-	1	-	-	1	1	1	1	S	1	
4.	As built drawings													
	a. Civil	-	-	1+1T	-	2+1T	5+1T	-	1	1+1T	-	1	S	
	b. E&M	-	-	1	2+1T	2+1T	-	5+1T	1+1T	1+1T	-	1	S	

S. No	Description	TSGENCO								CONSULTANT			Equipment Vendor	Remarks
		Director Projects	Director Technical	CE/Civil Thermal Projects Hyd.	CE/ TPC-I, Hyd	CE/ O&M/ KTPS	SE/ Civil KTPS	SE/E&M / KTPS	DE Constr. KTPS	Kolkata	HYD	KTPS		
D	Progress Report Monthly													
1.	Equipment vendor	1	1	1	2	1	1	2	1	1	1	1	S	
2.	M/s DCPL, Kolkata	1	1	2	2	1	1	2	1	S	1	1	Nil	
E	Test & Inspection Reports													
1.	Equipment manufacturer													
	a. Civil	1	1	1	2	1	1	1	-	11	1	1	S	
	b. E&M	1	1	-	2	1	-	1	1	11	1	1	S	
2.	M/s DCPL, Kolkata	1	1	-	2	1	-	1	1	S	-	1	-	
F	Instruction Manuals/Data Books													
1.	Equipment manufacturer													
	a. Civil	1	1	1+1T	1	1	6+1T	1	1	2+1T	1	1	S	
	b. E&M	1	1	-	3+1T	1	-	6+1T	2	3+1T	1	1	S	
2.	M/s DCPL, Kolkata	1	1	-	10+1T	1	-	15+1T	-	S	1	1	Nil	
G	M/s DCPL, Kolkata Criteria	1	1	1	8+1T	1	1	2	1	1	1	1	S	
H	Design Calculations	1	1	1	8+1T	1	1	2	1	1	1	1	S	
I	Final consulting Engineering Report	1	1	1	10	1	1	2	1	S	1	1	Nil	

S – Source, T – Transparency & Soft Copy on CD,

TSGENCO : Telangana State Power Generation Corporation Limited

Director, Projects, Hyd : Director/ Projects, TSGENCO, Vidyut Soudha, Hyderabad – 500 082

- a) Bidder shall apply in writing to Owner for handing over of the complete Control & Instrumentation System after successful demonstration of tests as specified up to "Availability Guarantee Test".
- b) Owner shall take over charge of the C&I system subject to fulfillment of the conditions enumerated hereunder :
- i) Site check-list prepared by Owner are fruitfully attended by Bidder and certified by Owner.
 - ii) Operation/ Instruction manuals are updated to incorporate changes made up to Availability Test Run.
 - iii) Drawings/ sketches are submitted as per Contract, on as- built basis.
 - iv) Close loop controls, Binary & Sequential controls should be working on auto and interlocks are demonstrated to be functional.
 - v) Equipment and system supplied by Bidder are in working condition.
 - vi) Short supply items, as per Contract, are refurbished by Bidder.
 - vii) The above conditions are in addition to fulfillment of any/all other contractual obligations of Bidder towards Owner. Partial handing-over of systems /equipments shall not be permissible, except if desired so by Owner in special cases.

11.00.00 TRAINING OF PERSONNEL

11.01.00 Bidder shall include in the proposal training of Owner's personnel of different categories for operation, maintenance and troubleshooting of the supplied equipment. Training courses shall be conducted by experienced personnel of Bidder. Course participants shall receive individual copies of technical manuals at the time the course is conducted. Upon completion of each course, training manuals shall be property of Owner. Bidder shall supply all updates and revisions to the manuals.

11.02.00 Training shall be provided to operating, programming and maintenance personnel. The training shall be conducted at original equipment designer / manufacturer's works. While the exact content and duration of such training shall be guided by Bidder's experience , following gives the basic and minimum requirement of operation and maintenance , troubleshooting training from Owner's point of view.

11.03.00 PLANT OPEARTION TRAINING

NO.OF PERSONNEL	CATEGORY OF PERSONNEL	SUBJECT	DURATION
12	Control Engineer	Main plant through DDCMIS OS	8 weeks each
16	Control Engineer	PADO System Usage	2 weeks each



**CUSTOMER SPECIFICATION
FOR VENTILATION SYSTEM
5X800 MW YADADRI TPS**

DOCUMENT NO.: PE-TS-417-554-A001

REVISION 00

DATE: FEB 2020

**SECTION: I
SUB-SECTION: C 2C
CUSTOMER SPECIFICATION-PAINTING SPECIFICATION**

TECHNICAL SPECIFICATION
FOR
PROTECTIVE LINING AND PAINTING

SECTION-XIII
TECHNICAL SPECIFICATION
FOR
PROTECTIVE LINING AND PAINTING

C O N T E N T S

<u>CLAUSE NO</u>	<u>DESCRIPTION</u>	<u>PAGE NO.</u>
1.00.00	INTENT OF SPECIFICATION	1
2.00.00	CODES & STANDARDS	1
3.00.00	GENERAL REQUIREMENTS	2
4.00.00	EQUIPMENT, MATERIAL AND SERVICES TO BE FURNISHED BY THE BIDDER	4
5.00.00	COATING PROCEDURE AND APPLICATION	7
6.00.00	TEST REQUIREMENTS	8
7.00.00	INFORMATION / DATA REQUIRED	12

SECTION-XIII**TECHNICAL SPECIFICATION****FOR****PROTECTIVE LINING AND PAINTING****1.00.00 INTENT OF SPECIFICATION**

1.01.00 This specification addresses the requirements of all labour, material, and appliances necessary with reference to preparations for lining / painting, application as well as finishing of all lining / painting for all mechanical and electrical equipment, piping and valves, structures etc. included under the scope of this Package.

1.02.00 The Bidder shall furnish and apply all lining, primers including wash primers if required, under-coats, finish coats and colour bands as described hereinafter or necessary to complete the work in all respects.

2.00.00 CODES & STANDARDS

2.01.00 The Bidder shall follow relevant Indian and International Standards wherever applicable in cleaning of surface, selection of lining material / paints and their application. The entire work shall conform to the following standards / specifications (latest revision or as specified).

- a) SSPC SP 10 / NACE 2 / : Near White Blast Cleaning
- b) SSPC PA 2 : Measurement of dry film Coating Thickness with magnetic gauges.
- c) ASTM D 4541 : Method for pull off strength using portable Adhesion Tester.
- d) NACE RP 0274 – 2004 : High-Voltage Electrical Inspection of Pipeline Coatings
- e) NACE SP 0188 – 2006 : Discontinuity (Holiday) Testing of New Protective Coatings on Conductive Substrates

-
- f) NACE RP 0169 – 2002 : Control of External Corrosion on Underground or Submerged Metallic Piping Systems
 - g) AWWA C 210 – 2007 : Liquid-Epoxy Coating Systems for the Interior and Exterior of Steel Water Pipelines
 - h) IS 3589:2001 Annexure B : Steel Pipes for Water and Sewage Specification.
 - i) AWWA C222-2000 : Polyurethane Coating for the Interior and Exterior of Steel Water Pipe and Fittings.
 - j) IS 13213 : 2000 : Polyurethane Full Gloss Enamel (Two pack)

3.00.00 GENERAL REQUIREMENTS

- 3.01.00** The steel surface preparation prior to actual commencement of coating shall conform to SSPC SP 10 / NACE 2 / Sa2½ (near white metal) with sand blasting.
- 3.02.00** The contractor shall submit a detailed written description in the form of a manual covering coating equipment, procedures, materials inspection test, and repair etc. to Owner/Consultant for approval.
- 3.03.00** The contractor shall also provide copies of test reports from NABL approved laboratory (like National Test House, Kolkata) in support of the paint/primer materials to be used shall conform to the specification requirement.
- 3.04.00** The contractor shall also provide certificates from paint/primer manufacturer mentioning the batch numbers, date of manufacture and shelf life etc. of the materials to be used. In addition to that Manufacturing Quality Plan (MQP) and Field Quality Plan (FQP) shall also be submitted prior to commencement of supply of material and field application.
- 3.05.00** Paint/coating application work at site shall be done either by paint manufacturer or by their authorized applicator. The authorized applicator shall have proper training & certification from manufacturer. Applicator shall possess all the necessary specialized equipment and manpower experienced in similar job.

- 3.06.00 Applied coating shall be tested for dry film thickness, holiday (electrical inspection for continuity) and adhesion as per relevant standard such as SSPC PA 2, NACE RP 0274 and ASTM D 4541.
- 3.07.00 If necessary, the material may be heated and applied by airless spray / plural component spray system.
- 3.08.00 Manufacturer's specific recommendation, if any, shall be followed during application of lining / paints.
- 3.09.00 In areas where there is danger of spotting automobiles or other finally finished equipment or building by wind borne particles from paint spraying, a Purchaser approved method shall be adopted.
- 3.10.00 The colour scheme of the entire Plant, covered under this specification shall be approved by the Purchaser in advance before application.
- 3.11.00 All indoor and outdoor piping, insulated as well as uninsulated will have approved colour bands painted on the pipes at conspicuous places throughout the system, as approved by Purchaser.
- 3.12.00 Inside surfaces of vessels / tanks shall be protected by anticorrosive paints or rubber lining as required / specified elsewhere in the specification. External surfaces of all vessels / tanks shall be protected by anti corrosive painting.
- 3.13.00 For vessels / tanks requiring lining and epoxy painting all inside surface shall be blast cleaned using non-siliceous abrasive after usual wire brushing.
- 3.14.00 Natural rubber lining shall be provided on the inside of vessels / tanks as required / specified elsewhere in the specification, in three layers resulting in a total thickness not less than 4.5 mm.
- 3.15.00 Surface hardness of rubber lining shall be 65 +/- 5 deg. A (shore).
- 3.16.00 After the lining is completed, the vessels / tanks shall not be subjected to any prolonged exposure to direct sunlight in course of its transportation, erection etc. They shall not be stored in direct sunlight. No further lining or burning shall be carried out on the vessel, after application of the lining.

- 3.17.00 All lining projecting outside of the vessel shall be protected adequately from mechanical damages during shipment, handling storage etc.
- 3.18.00 Suitable warnings, indicating the special care that must be taken with respect to these lined vessels shall be stenciled on their outside surface with the letters at least 12 mm high.
- 3.19.00 All insulated piping shall have aluminium sheet jacketing.

4.00.00 EQUIPMENT, MATERIAL AND SERVICES TO BE FURNISHED BY THE BIDDER

- 4.01.00** After erection at site, the outside surfaces of all equipment having a shop coat shall be given further priming coat and finished coats of paint as detailed in following clauses. However, if the painting system is such that the shop coat and primer coat to be applied at site are not compatible, then shop coat has to be removed from the surface of equipment before application of primer coat with prior blasting.

All factory finished paints shall be touched up at site as required.

All uninsulated piping shall be finished with final paintings after use of proper wash primer and primer. Aluminium sheet jacketed piping need not be painted. Colour bands of Purchaser's approved shade shall however be applied on jacketed piping near walls or partitions, at all junctions, near valves and all other places as instructed by the Purchaser. All structures shall be painted with approved paint.

4.02.00 Surface Preparation

- 4.02.01 Unless mentioned otherwise, all rust and mill scale shall be removed by blasting to Sa 2-1/2 Swiss Standard before applying the primer.
- 4.02.02 Special care shall be taken to remove grease and oil by means of suitable solvents like Trichloroethylene or Carbon Tetrachloride.
- 4.02.03 The minimum degree of surface preparations for all equipment, piping, fittings, valves, structures etc. shall be "Near White" according to Steel Structure, Painting Council-SSPC-SP-10 before application of any primer/paint.

4.03.00 Painting

- 4.03.01 Specification for application of paints for external surfaces protection of vessels / tanks / equipment / piping / fittings / valves etc. to be installed indoor shall be as follows :
- a) Surface preparation shall be done either manually or by any other approved method.
 - b) Primer Coat shall consist of one coat (minimum DFT of 50 microns) of chlorinated rubber based zinc phosphate.
 - c) Intermediate Coat (or Under Coat) shall consist of one coat (minimum DFT of 50 microns) of chlorinated rubber based paint pigmented with Titanium Dioxide.
 - d) Top Coat shall consist of one coat (minimum DFT of 50 microns) of chlorinated rubber paint of approved shade and colour with glossy finish.
 - e) Total DFT of paint system shall not be less than 150 microns.
- 4.03.02 Specification for application of paints for external surfaces protection of vessels / tanks / equipment / piping / fittings / valves etc to be installed **outdoor** shall be as follows :
- a) Surface preparation shall be done by means of sand blasting, which shall conform to Sa 2-1/2 Swiss Standard.
 - b) Primer Coat shall consist of one coat (minimum DFT of 100 microns) of epoxy resin based zinc phosphate primer.
 - c) Intermediate Coat (or Under Coat) shall consist of one coat (minimum DFT of 100 microns) epoxy resin based paint pigmented with Titanium Dioxide.
 - d) Top Coat shall consist of one coat (minimum DFT of 75 microns) of epoxy paint of approved shade and colour with glossy finish. Additional one coat (minimum DFT of 25 microns) of Finish Coat of polyurethane shall be provided.
 - e) Total DFT of paint system shall not be less than 300 microns.
- 4.03.03 Specification for application of paints for external surfaces protection of steel pipes and fittings which are **buried underground / laid inside a hume pipe & or submerged Under Water and laid under Pipe Trenches** (in road/rail/pipe or trench crossings) shall be as follows :

External surface of the pipe, fittings, specialties etc. handling raw water/clarified water/filter water shall be painted with one coat of two part chemically cured polyurethane primer of min 50 micron dry film thickness followed by three or maximum four coats of two part solvent less polyurethane to build up coating of dry film thickness of 2000 micron including primer coat.

- 4.03.04 Specification for application of paints for **internal surface protection of large diameter pipes** (sizes above 600 mm NB and above) if any, shall be as follows :
- a) All Internal surfaces of steel pipes, fittings, specialties etc. buried underground or located within pipe trenches shall be given epoxy coating to protect them from (except for drinking water service, where the compatible painting shall be so selected to meet relevant quality standards) corrosion.
 - b) Internal surface of the pipe should be coated with one coat of two part epoxy primer with not less than 50 micron DFT (dry film thickness) followed by two part polyamide cured solvent less epoxy.
 - c) The minimum dry film thickness (DFT) of internal lining shall be 600 micron.
- 4.03.05 Specification for application of paints for protection of **internal surfaces of DM Water Storage Tank(s)** shall be as follows :
- a) Primer - One coat of epoxy primer containing high level of Zinc Phosphate anticorrosive pigment. Total Dry Film Thickness (DFT) of primer shall not be less than 125 microns.
 - b) Finish Paint - Three (3) coats Polyamine HB Epoxy Paint. Total Dry Film Thickness (DFT) of finish paint shall not be less than 125 microns per coat.
 - c) Total thickness of primer and paint should not be less than 500 microns.
- 4.03.06 All motors, local push button stations, cable racks, structures used for supports etc. are to be painted with acid proof paint.
- 4.03.07 The following surfaces shall not be painted - stainless steel, galvanized steel, aluminum, copper, brass, bronze and other nonferrous materials.
- 4.03.08 No painting or filler shall be applied until all repairs, hydrostatic tests and final shop inspection are completed.

4.03.09 All machined surfaces shall have two (2) coats of water repellent grease after thorough cleaning.

5.00.00 COATING PROCEDURE AND APPLICATION

5.01.00 Surface Preparation :

Pipe shall be blast cleaned by sand. The cleanliness achieved prior to application shall be in accordance with the requirement of SSPC SP 10 / NACE 2 / Sa2½ of ISO 8501 (near white metal)

- a) The blast pattern or profile depth shall be 40 to 100 micron and shall be measured by dial micrometer.
- b) Before sand blasting is started or during blasting or coating, temperature of the pipe surface should be more than 3°C above dew point temperature. Blast cleaned surface should be primed within 4 hours and shall be protected from rainfall or surface moisture and shall not be allowed to flash rust. If the rust occurs, the surface again to be prepared by sand blasting or wire brushing.

5.02.00 Application of Epoxy Coating

- a) Coating shall be applied when
 - i) When the pipe surface temperature shall be atleast 3°C above dew point temperature.
 - ii) The temperature of mixed coating material and the pipe at the time of application shall not be lower than 10°C or greater than 50°C.
- b) Material preparation shall be in accordance with manufacturer's recommendations.
- c) Application of epoxy coating system :

The epoxy coating system shall be applied as per recommendation of the manufacturer and shall be applied by airless spray / plural component spray machine. For more than one coat, the second shall be applied with the time limits as recommended by the manufacturer.

5.03.00 Application of PU Coating

- a) PU coating shall be applied when the pipe surface temperature atleast 3°C above dew point temperature (when R.H is more than 85%).
- b) Material preparation and application shall be done as per manufacturer recommendation.

6.00.00 TEST REQUIREMENTS :**6.01.00 Measurement of dry film thickness**

Measurement of dry film thickness of coating : Coating thickness shall be in the range of $\pm 20\%$ and as per SSPC PA 2.

6.01.01 Apparatus / Instrument:-

The instrument used for dry film thickness may be Type 1 pull of gauges or Type 2 electronic gauges.

6.01.02 Procedures:-

- a) Number of measurements:
For 100 square feet (9.29 square meters), five (5) spots per test area (each spot is 3.8 cm) in diameter. Three gauge readings per spot (average becomes the spot measurement).
- b) If the structure is less than 300 square feet, each 100 square feet should be measured.
- c) If the structure is between 300 and 1000 sq ft, select 3 random 100 square feet test areas and measure.
- d) For structure exceeding 1000 square feet, select 3 random 100 square feet testing areas for the first 1000 sq ft and select 1 random 100 square feet testing area for each additional 1000 square feet
- e) Coating thickness Tolerance: Individual reading taken to get a representative measurement for the spot are unrestricted (usually low or high readings are discarded). Spot measurements (the average of 3 gauge readings) must be within 80% of the minimum thickness and 120% of the maximum thickness. Area measurement must be within specified range.

6.02.00 Electrical Inspection (Holiday) Test

- 6.02.01 All the coated / lined pipes shall be tested with an approved high voltage holiday detector preferably equipped with an audio visual signaling device to indicate any faults, holes, breaks or conductive particles in the protective coating.
- 6.02.02 The applied output voltage of holiday detector shall have a spark discharge of thickness equal to at least twice the thickness of the coating to assure adequate inspection voltage and compensate for any variation in coating thickness. The electrode shall be passed over the coated surface at approximately half the spark discharge distance from the coated surface only one time at the rate of approximately 10 to 20m/min. The edge effect shall be ignored. Excessive voltage shall be avoided as it tends to induce holiday in the coated surface thereby giving erroneous readings.
- 6.02.03 While selecting test voltages, consideration should be given to the tolerance on coating thickness and voltage should be selected on the basis of maximum coating thickness likely to be encountered during testing of a particular pipe.
- The testing voltage shall be calculated by using following formula. (as per NACE 0274 : 2004)
- Testing Voltage $V = 7900 \sqrt{T} \pm 10$ percent where T is the average coating thickness in mm.
- 6.02.04 Any audio visual sound or spark leads to indicate pinhole, break or conductive particle.
- 6.03.00 Adhesion Pull off Test :**
- After holiday the coated surface is subjected to adhesion pull off test as per ASTM D 4541.
- 6.03.01 Apparatus / Instrument: Adhesion tester consists of three basic components:
- A hand wheel, a black column containing a dragging indicator pin and scale in the middle and a base containing three legs and a pulling "Jaw" at the bottom and also dollies.
- 6.03.02 Prepare the test surface :
- Once test area is selected, test area shall be free of grease, oil, dirt, water. The area should be flat surfaces and large enough to accommodate the specified number of replicate test.
- 6.03.03 Prepare Dolly (Test Pull Stub) :

The dolly is a round, two sided aluminium fixture. Both sides of the dolly looks same, however, one side sloped on top surface while flat on bottom surface. As the surface of the dolly is polished aluminium, roughen the same using a coarse sand paper.

6.03.04 Select an adhesive:

Use araldite, a 100% solid epoxy adhesive. This adhesive requires at least 24 hours at room temperature to cure.

6.03.05 Attach the dolly to the surface.

- a) Using a wooden stick, apply an even layer of adhesive to the entire contact surface area of the dolly.
- b) Carefully remove the excessive adhesive by using a cotton swab. Allow the adhesive to fully cure before performing the adhesion test.
- c) Attach the dolly to the coated surface and gently push downward to displace any excessive adhesive.
- d) Push the dolly inward against the surface, then apply tape across the head of the dolly.

6.03.06 Adhesion Test Procedure

- a) Attach the adhesion tester to the dolly by rotating the hand wheel counter clockwise to lower the jaw of the device.
- b) Slide the jaw completely under the head of the dolly. Position the three legs of the instruments so that they are sitting flat on the coated surface.
- c) Slide the dragging indicator pin on the black column to zero by pushing it downward.
- d) Firmly hold the base of the instrument in one hand and rotate the handwheel clockwise to raise the jaw of the device that is attached to the head of the dolly. The dragging indicator pin will move upward on the black column as the force is increased and will hold the reading. Apply the tension using a moderate speed. Continue to increase the tension on the head of the dolly until (a) the minimum PSI/MPa/Kg/cm² required by project specification is exceeded and the test is discontinued, (b) the maximum PSI/MPa/Kg/cm² of adhesion tester has been achieved and dolly is still attached, (c) The force applied by the adhesion tester causes the dolly to dislodge.

e) Read the scale and record the adhesion value.

6.04.00 Coating Repair

Defective Coating shall be repaired in accordance with the following subsections.

6.04.01 Surface Preparation:

Accessible areas of pipe requiring coating repairs shall be cleaned to remove debris and damaged coating using surface grinders or other means. The adjacent coating shall be feathered by sanding, grinding or other method. Accumulated debris shall be removed by blowing with contaminant free air or wiping with clean rags.

6.04.02 Areas not accessible for coating repair such as interior surfaces of small diameter pipe shall be reprocessed and recoated.

6.04.03 Coating Application :

The coating system shall be applied to the prepared areas in accordance with procedure.

6.04.04 Repair Inspection :

Repaired portion shall be electrically inspected using a holiday detector.

6.05.00 Welded Field Joints

6.05.01 Preparation :

The weld joints shall be cleaned so as to be free from mud, oil, grease, welding flux, weld spatter and other foreign contaminants. The cleaned metal surfaces of the weld joint shall then be blasted or abraded using rotary abrading pads. The adjacent liquid Epoxy / PU coating shall be feathered by abrading the coating surface for a distance of 25 mm.

6.05.02 Electrical Inspection :

After curing the coating system applied to the welding joints shall be holiday tested. Any holidays indicated by the detector shall be marked with chalk to identify the area of repair.

7.00.00 INFORMATION/DATA REQUIRED

The Bidder shall submit complete list of paints and primers proposed, giving detail information, such as, chemical composition, drying time etc. and also unit rates for application of each type of paint along with supply shall be furnished.



**TECHNICAL SPECIFICATION
FOR VENTILATION SYSTEM
5X800 MW YADADRI TPS**

DOCUMENT NO.: PE-TS-417-554-A003

REVISION 00

DATE: FEB 2020

**SECTION: I
SUB-SECTION: C3
TECHNICAL SPECIFICATION (ELECTRICAL PORTION)**

**TELANGANA STATE POWER GENERATION
CORPORATION LTD
TELANGANA STATE, INDIA**

5x800 MW YADADRI TPS

**VENTILATION SYSTEM TECHNICAL SPECIFICATION
(ELECTRICAL PORTION)**



**BHARAT HEAVY ELECTRICALS LIMITED
POWER SECTOR
PROJECT ENGINEERING MANAGEMENT,
NOIDA, U.P., INDIA**



TITLE:
**VENTILATION SYSTEM TECHNICAL
SPECIFICATION
(ELECTRICAL PORTION)**
5X800 MW YADADRI TPS

SPECIFICATION NO.
VOLUME NO. : **II-B**
SECTION: **I**
REV NO. : **00** DATE: 03/04/2020
SHEET: 1 OF 1

CONTENTS

TITLE	NO OF SHEETS
COVER SHEET	1
CONTENT	1
SPECIFIC TECHNICAL REQUIREMENTS FOR LV MOTORS	3
BASIC TECHNICAL FEATURES OF LV MOTORS	7
ELECTRICAL SCOPE BETWEEN BHEL & VENDOR	2
ELECTRICAL LOAD DATA FORMAT	1
DATASHEET-A	1
DATASHEET-C	2
CABLE SCHEDULE FORMAT	1
EXPLANATORY NOTES FOR CABLE LISTING	2
TOTAL	21

NOTE: THE REQUIREMENTS MENTIONED IN SECTION-I SHALL PREVAIL AND GOVERN IN CASE OF CONFLICT BETWEEN THE SAME AND THE CORRESPONDING REQUIREMENTS MENTIONED IN THE DESCRIPTIVE PORTION IN SECTION-II.



**TECHNICAL SPECIFICATION FOR
VENTILATION SYSTEM
5X800 MW YADADRI TPS
(ELECTRICAL PORTION)**

SPECIFICATION NO.

VOLUME NO. : **II-B**

SECTION : **I**

REV NO. : **00** DATE: 03/04/2020

SHEET : 1 OF 3

**SPECIFIC TECHNICAL REQUIREMENTS
FOR LV MOTORS (ELECTRICAL)**

SECTION-I

	TECHNICAL SPECIFICATION FOR VENTILATION SYSTEM 5X800 MW YADADRI TPS (ELECTRICAL PORTION)	SPECIFICATION NO.
		VOLUME NO. : II-B
		SECTION : I
		REV NO. : 00 DATE: 03/04/2020
		SHEET : 1 OF 3

SPECIFIC TECHNICAL REQUIREMENTS: ELECTRICAL

1.0 EQUIPMENT & SERVICES TO BE PROVIDED BY BIDDER:

- a) Services and equipment as per “Electrical Scope between BHEL and Vendor”.
- b) Any item/work either supply of equipment or erection material which have not been specifically mentioned but are necessary to complete the work for trouble free and efficient operation of the plant shall be deemed to be included within the scope of this specification. The same shall be provided by the bidder without any extra charge.
- c) Supply of mandatory spares as specified in the specifications of mechanical equipment’s.
- d) Electrical load requirement for VENTILATION SYSTEM.
- e) All equipment shall be suitable for the power supply fault levels and other climatic conditions mentioned in the enclosed project information.
- f) Bidder to furnish list of makes for each equipment at contract stage, which shall be subject to customer/BHEL approval without any commercial and delivery implications to BHEL
- g) Various drawings, data sheets as per required format, Quality plans, calculations, test reports, test certificates, operation and maintenance manuals etc. shall be furnished as specified at contract stage. All documents shall be subject to customer/BHEL approval without any commercial implication to BHEL.
- h) Motor shall meet minimum requirement of motor specification.
- i) Vendor to clearly indicate equipment locations and local routing lengths in their cable listing furnished to BHEL.
- j) Cable BOQ worked out based on routing of cable listing provided by the vendor for “both end equipment in vendor’s scope” shall be binding to the vendor with +10 % margin to take care of slight variation in routing length & wastages.

2.0 EQUIPMENT & SERVICES TO BE PROVIDED BY PURCHASER FOR ELECTRICAL & TERMINAL POINTS:

Refer “Electrical Scope between BHEL and Vendor” Annexure - I.

3.0 DOCUMENTS TO BE SUBMITTED ALONG WITH BID

- 3.1 The electrical specification without any deviation from the technical/quality assurance requirements stipulated shall be deemed to be complied by the bidder in case bidder furnishes the overall compliance of package technical specification in the form of compliance certificate/No deviation certificate.
- 3.2 No technical submittal such as copies of data sheets, drawings, write-up, quality plans, type test certificates, technical literature, etc., is required during tender stage. Any such submission even if made, shall not be considered as part of offer.



**TECHNICAL SPECIFICATION FOR
VENTILATION SYSTEM
5X800 MW YADADRI TPS
(ELECTRICAL PORTION)**

SPECIFICATION NO.

VOLUME NO. : **II-B**

SECTION : **I**

REV NO. : **00** DATE: 03/04/2020

SHEET : 1 OF 3

4.0 List of enclosures:

- a) Electrical scope between BHEL & vendor (Annexure –I)
- b) Technical specification for motors.
- c) Datasheets for motors.
- d) Electrical Load data format (Annexure –II)
- e) BHEL cable listing format (Annexure –III)
- f) Quality plan for motors.

ELECTRICAL SCOPE BETWEEN BHEL AND VENDOR**PACKAGE: VENTILATION SYSTEM****PROJECT: 5 x 800 MW YADADRI TPS**

S.NO	DETAILS	SCOPE SUPPLY	SCOPE E&C	REMARKS
1	415V MCC	BHEL	BHEL	240 V AC (supply feeder)/415 V AC (3 PHASE 4 WIRE) supply shall be provided by BHEL based on load data provided by vendor at contract stage for all equipment supplied by vendor as part of contract. Any other voltage level (AC/DC) required will be derived by the vendor.
2	Local Push Button Station (for motors)	BHEL	BHEL	Located near the motor.
3	Power cables, control cables and screened control cables for a) both end equipment in BHEL's scope b) both end equipment in vendor's scope c) one end equipment in vendor's scope	BHEL BHEL BHEL	BHEL Vendor BHEL	1. For 3.b) & c): Sizes of cables required shall be informed by vendor at contract stage (based on inputs provided by BHEL) in the form of cable listing. Finalisation of cable sizes shall be done by BHEL. Vendor shall provide lugs & glands accordingly. 2. Termination at BHEL equipment terminals by BHEL. 3. Termination at Vendor equipment terminals by Vendor.
4	Junction box for control & instrumentation cable	Vendor	Vendor	Number of Junction Boxes shall be sufficient and positioned in the field to minimize local cabling (max 10-12 mtrs) and trunk cable.
5	Any special type of cable like compensating, co-axial, prefab, MICC, fibre optical etc.	Vendor	Vendor	Refer C&I portion of specification for scope of fibre Optical cables if used between PLC/ microprocessor & DCS.
6	Cable trays, accessories & cable trays supporting system 100/ 50 mm cable trays/ Conduits/ Galvanised steel cable troughs for local cabling	BHEL Vendor	BHEL Vendor	Local cabling from nearby main route cable tray (BHEL scope) to equipment terminal (vendor's scope) shall be through 100/ 50 mm. cable trays/ conduits/ Galvanised steel cable troughs, as per approved layout drawing during contract stage.
7	Cable glands ,lugs and bimetallic strip for equipment supplied by Vendor	Vendor	Vendor	1. Double compression Ni-Cr plated brass cable glands 2. Solder less crimping type heavy duty tinned copper lugs for power and control cables.
8	Conduit and conduit accessories for cabling between equipments supplied by vendor	Vendor	Vendor	Conduits shall be medium duty, hot dip galvanised cold rolled mild steel rigid conduit as per IS: 9537.
9	Lighting	BHEL	BHEL	
10	Equipment grounding & lightning protection	BHEL	BHEL	Refer note no. 4 for electronic earthing
11	Below grade grounding	BHEL	BHEL	
12	LT Motors with base plate and foundation hardware	Vendor	Vendor	Makes shall be subject to customer/ BHEL approval at contract stage.
13	Mandatory spares	Vendor	-	Vendor to quote as per specification.
14	Recommended O & M spares	Vendor	-	As specified elsewhere in specification

ELECTRICAL SCOPE BETWEEN BHEL AND VENDOR**PACKAGE: VENTILATION SYSTEM**





S.NO	DETAILS	SCOPE SUPPLY	SCOPE E&C	REMARKS
15	Any other equipment/material/service required for completeness of system but not specified above (to ensure trouble free and efficient operation of the system).	Vendor	Vendor	
16	a) Input cable schedules (Control & Screened Control Cables) b) Cable interconnection details for above c) Cable block diagram	Vendor Vendor Vendor	- - -	Cable listing for Control and Instrumentation Cable and electronic earthing cable in enclosed excel format shall be submitted by vendor during detailed engineering stage.
17	Electrical Equipment & cable tray layout drawings	Vendor	-	For ensuring cabling requirements are met, vendor shall furnish Electrical equipment layout & cable tray layout drawings (both in print form as well as in AUTOCAD) of the complete plant (including electrical area) indicating location and identification of all equipment requiring cabling, and shall incorporate cable trays routing details marked on the drawing as per PEM interface comments. Cabling arrangement of the same (wherever overhead cable trays, trenches, cable ducts, conduits etc.) shall be decided during contract stage. Electrical equipment layout & cable tray layout drawing shall be subjected to BHEL/ customer approval without any commercial implications to BHEL.
18	Electrical Equipment GA drawing	Vendor	-	For necessary interface review.

NOTES:

1. Make of all electrical equipment/ items supplied shall be reputed make & shall be subject to approval of BHEL/customer after award of contract.
2. All QPs shall be subject to approval of BHEL/customer after award of contract without any commercial implication.
3. In case the requirement of Junction Box arises on account of Power Cable size mis-match due to vendor engineering at later stage, vendor shall supply the Junction Box for suitable termination.
4. Vendor shall indicate location of Electronic Earth pit in their Civil assignment drawing.

BASIC TECHNICAL FEATURES FOR LT MOTORS

(FOR BHEL-PEM SCOPE PACKAGES)

					CUSTOMER: TELANGANA STATE POWER GENERATION CORPORATION LTD TELANGANA, INDIA 5 x 800 MW YADADRI TPS, NALGONDA																	
					OWNER'S CONSULTANT: TATA CONSULTING ENGINEERS LTD BANGLORE INDIA																	
					JOB NO. 417 STATUS CONTRACT DISTRIBUTION					BHARAT HEAVY ELECTRICALS LTD POWER SECTOR PROJECT ENGINEERING MANAGEMENT NOIDA												
<small>COPY RIGHT AND CONFIDENTIAL The information on this document is the property of BHARAT HEAVY ELECTRICALS LIMITED it must not be used directly or indirectly in any way detrimental to the interest of the company.</small>															DEPT CODE I		NAME HC		SIGN s.d.		DATE 07.12.17	
REV. 02		DATE 16.08.2018		ALTD HC		CHD AS		APPD PD		REV. 01		DATE 		ALTD 		CHD 		APPD 				
REVISED IN LINE WITH CUSTOMER COMMENTS DT. 13.08.2018					REVISED IN LINE WITH CUSTOMER COMMENTS DT. 19.04.2018					TITLE BASIC TECHNICAL FEATURES FOR LT MOTORS												
DEPT. SIGN					SCALE 					DRAWING NO. PE-DC-417-565-E003												
SHEET 1 OF 7					REV. 02																	



**5 x 800 MW YADRADRI TPS
BASIC TECHNICAL FEATURES
FOR LT MOTORS
(FOR BHEL-PEM SCOPE PACKAGES)**

Doc. No.	PE-DC-417-565-E003
Rev. No.	02
Dated	16-08-2018
Page	2 of 7

1.0 This document covers the basic technical features of low tension (LT) squirrel cage induction AC motors employed for driving auxiliaries of BHEL-PEM scope packages in **5 x 800 MW YADRADRI TPS**.

2.0 CODES AND STANDARDS

All motors shall conform to the latest applicable standards as listed below;

- 1) Three phase induction motors: IS: 12615, IEC: 60034
- 2) Single phase AC motors: IS: 996, IEC: 60034
- 3) Crane duty motors: IS: 3177, IEC: 60034
- 4) Energy Efficient motors: IS 12615 or IEC: 60034-30 with Efficiency class IE3

3.0 DESIGN REQUIREMENTS

3.1 **Service Conditions**

The motors will be installed in hot, humid and tropical atmosphere highly polluted at places with coal dust and/or fly ash. For motor installed outdoor and exposed to direct sunrays, the effect of solar heat shall be considered in the determination of the design ambient temperature.

The design ambient temperature shall be 50 deg C.

3.2 Supply system and rated voltage of motors

KW rating	Supply system	Rated voltage of motor
Upto 0.2 kW	240V/415 V	240V/415 V
Above 0.2 kW & up to 175kW	415 V	415 V

3.2.1 Supply voltage & variations shall be as follows:-

Voltage variation (AC Supply): (+/-) 10%
Frequency variation : (+) 3% to (-) 5%
Combined V & F variation : 10% (sum of absolute values)

During starting of large motor, the voltage may drop to 80% of the rated voltage for a period of 60 seconds. All electrical equipment while running shall successfully ride over such period without affecting system performance.

3.2.2 Motors shall be capable of running continuously at rated output for each of the conditions specified.

3.3 **Motor Rating**

All motors shall be rated for continuous duty. They shall also be suitable for long period of inactivity. LT motor rating at 50 degree C shall have at least 15% margin over the input power requirement of the driven equipment at rated duty point unless stated otherwise in driven equipment specification. The motor characteristics shall match the requirements of the driven equipment so that adequate starting, accelerating, pull up, break down and full load torques are available for the intended service.

3.4 **Starting Requirements**

3.4.1 Motor shall start smoothly and rapidly. Motor characteristics such as speed, starting torque, break away torque and starting time shall be properly co-ordinated with the requirements of driven equipment. The



**5 x 800 MW YADRADRI TPS
BASIC TECHNICAL FEATURES
FOR LT MOTORS
(FOR BHEL-PEM SCOPE PACKAGES)**

Doc. No.	PE-DC-417-565-E003
Rev. No.	02
Dated	16-08-2018
Page	3 of 7

accelerating torque at any speed with the minimum starting voltage shall be at least 10% higher than that of the driven equipment.

- 3.4.2 Motors shall be capable of starting and accelerating the load with direct on line starting without exceeding acceptable winding temperature.

The limiting value of voltage at rated frequency under which a motor will successfully start and accelerate to rated speed with load shall be taken to be a constant value of 85 (eighty five) percent rated voltage.

- 3.4.3 Continuous duty LT motors up to 175 KW Output rating (at 50 deg. C ambient temperature), shall be Premium efficiency (IE3) as per IEC: 60034-30/ IS: 12615 and the locked rotor current of motors shall as per IS 12615.

However, as per system requirement drives rated in the range of 160-210 KW may be considered in either 415V or 3.3 KV

- 3.4.4 Pump motor subject to reverse rotation shall be designed to withstand the stresses encountered when starting with shaft rotating at 125% rated speed in reverse direction. The motors shall be designed to withstand 120% of rated speed for 2 minutes without any mechanical damage.

- 3.4.5 The following frequency of starts shall apply

- i) Three cold starts in succession with the motor being initially at a temperature not exceeding the ambient temperature.
- ii) Two hot starts in succession with the motor being initially at a temperature not exceeding the rated load temperature.
- iii) Three equally spread starts in an hour the motor being initially at a temperature not exceeding the rated load operating temperature (not to be repeated in the second successive hour)

- 3.4.6 Locked motor withstand time of hot motors at 110% rated voltage shall be as follows:

- a) For motors with starting time upto 20 sec.
- at least 3 sec. more than starting time.
- b) For motor with starting time above 20 secs but not exceeding 45 secs.
- at least 5.0 sec. more than starting time.
- c) For motors with starting time above 45 secs.
- at least 10%. more than starting time.

The starting time of the motor referred above is at minimum permissible voltage. Wherever the above requirements are not complied with, speed switches of approved make & type shall be provided to bypass the locked rotor protection for a pre-selected time during starting of motors. The speed switches shall have one NO & one NC contacts having maximum interrupting capacity of 5 Amps at 240V AC and 0.25 amps at 220 V DC.

Hot thermal withstand curve shall have a margin of at least 10% over the full load current of the motor to permit relay setting utilising motor rated capacity.



**5 x 800 MW YADRADRI TPS
BASIC TECHNICAL FEATURES
FOR LT MOTORS
(FOR BHEL-PEM SCOPE PACKAGES)**

Doc. No.	PE-DC-417-565-E003
Rev. No.	02
Dated	16-08-2018
Page	4 of 7

3.5 Running Requirements

- 3.5.1 Motor shall run continuously at rated output over the entire range of voltage and frequency variations as given above.
- 3.5.2 The motor shall be capable of operating satisfactorily at full load for 5 minutes without injurious heating with 75% rated voltage at motor terminals.
- 3.5.3 The motor shall be designed to withstand momentary overload of 60% of full load torque for 15 second without any damage.

3.6 Stress during bus Transfer

- 3.6.1 The motor may be subjected to sudden application of 150% rated voltage during bus transfer, due to the phase difference between the incoming voltage and motor residual voltage.
- 3.6.2 The motor shall be designed to withstand any torsional and/or high current stresses, which may result, without experiencing any deterioration in the normal life and performance characteristics.

4.0 SPECIFIC REQUIREMENTS

4.1 Enclosure

All motor enclosures for outdoor, semi-outdoor & indoor application shall conform to the degree of protection IP-55 unless otherwise specified. Motor for outdoor or semi-outdoor service shall be of weather-proof construction with canopy. For hazardous area approved type of increased safety enclosure shall be furnished.

4.2 Cooling

- 4.2.1 The motor shall be self-ventilated type, either totally enclosed fan cooled IC 411(TEFC), totally enclosed tube ventilated IC 511(TETV) or closed air circuit air- cooled IC 611(CACA).

4.3 Winding and Insulation

All insulated winding shall be of copper. All motors shall have class F insulation but limited to class B temperature rise. Windings shall be impregnated to make them non-hygroscopic and oil resistant.

Tropical Protection

All motors shall have fungus protection involving special treatment of insulation and metal against fungus, insects and corrosion.

All fittings and hardware shall be corrosion resistant.

4.4 Bearings

- 4.4.1 Motor shall be provided with antifriction bearings, unless sleeve bearings are required by the motor application. Bearings shall be rated for minimum service life of 40,000Hrs.
- 4.4.2 Vertical shaft motors shall be provided with thrust and guide bearings. Thrust bearing of tilting pad type is preferred.



**5 x 800 MW YADRADRI TPS
BASIC TECHNICAL FEATURES
FOR LT MOTORS
(FOR BHEL-PEM SCOPE PACKAGES)**

Doc. No.	PE-DC-417-565-E003
Rev. No.	02
Dated	16-08-2018
Page	5 of 7

- 4.4.3 Bearings shall be provided with seals to prevent leakage of lubricant or entrance of foreign matters like dirt, water etc. into the bearing area.
- 4.4.4 Sleeve bearings shall be split type, ring oiled, with permanently aligned, close running shaft sleeves.
- 4.4.5 Grease lubricated bearings shall be pre-lubricated and shall have provisions for in-service positive lubrication with drains to guard against over lubrication. LT motors 15kW and above shall be provided with external greasing arrangement.
- 4.4.6 Oiled bearing shall have an integral self-cooled oil reservoir with oil ring inspection ports, oil sight glass with oil level marked for standstill and running conditions and oil fill and drain plugs.
- 4.4.7 Forced lubricated or water cooled bearing shall be used as per requirement.
- 4.4.8 Lubricant shall not deteriorate under all service conditions. The lubricant shall be limited to normally available types with IOC equivalent.
- 4.4.9 Bearings shall be insulated as required to prevent shaft current and resultant bearing damage.

4.5 Noise & Vibration

- 4.5.1 For 415V motors, maximum double amplitude vibrations upto 1500 rpm shall be 40 microns and 15 microns upto 3000 rpm.
- 4.5.2 The noise level shall not exceed 85db (A) at 1.5 meters from the motor.

4.6 Motor Terminal Box

- 4.6.1 Motor terminal box shall be detachable type and located in accordance with Indian Standards clearing the motor base- plate/ foundation
- 4.6.2 Terminal box shall be capable of being turned 360 deg in steps of 90 Deg. for LT motors unless otherwise approved.
- 4.6.3 The terminal box shall be split type with removable cover with access to connections and shall have the same degree of protection as motor.
- 4.6.4 The terminal box shall have sufficient space inside for termination/connection of XLPE insulated armoured aluminium cables.
- 4.6.5 Terminals shall be stud or lead wire type, substantially constructed and thoroughly insulated from the frame.
- 4.6.6 The terminals shall be clearly identified by phase markings, with corresponding direction of rotation marked on the non-driving end of the motor.
- 4.6.7 The terminal box shall be capable of withstanding maximum system fault current for a duration of 0.25 sec.
- 4.6.8 Motor terminal box shall be furnished with suitable cable lugs and double compression brass glands to match with cable used.
- 4.6.9 The gland plate for single core cable shall be non-magnetic type. A suitable cable adopter box shall be provided if the cable size does not allow the direct termination in the main TB.



**5 x 800 MW YADRADRI TPS
BASIC TECHNICAL FEATURES
FOR LT MOTORS
(FOR BHEL-PEM SCOPE PACKAGES)**

Doc. No.	PE-DC-417-565-E003
Rev. No.	02
Dated	16-08-2018
Page	6 of 7

4.6.10 Minimum clearances to be provided between phase to phase and phase to earth shall be as under-

Voltage Rating of Motor Minimum Ph-Ph & Ph-Earth clearance
0.415 kV : 25 mm

Note: In case it is not possible to maintain these clearances, the live parts shall be totally insulated from earth and other Phases. Adequate clearances shall be provided for cable connections.

4.7 Grounding

The frame of each motor shall be provided with two separate and distinct grounding pads complete with tapped hole, GI bolts and washer.
The cable terminal box shall have a separate grounding pad.

4.8 Rating Plate

In addition to the minimum information required by IS, the following information shall be shown on motor rating plate:

- Temperature rise in Deg.C under rated condition and method of measurement.
- Degree of protection.
- Bearing identification no. and Type of lubrication, Quantity and frequency/ time interval
- Location of insulated bearings.

5.0 ACCESSORIES

5.1 SPACE HEATERS

Motor of rating 30 kW and above shall be provided with space heaters, suitably located for easy removal or replacement. The space heater shall be rated 240 V, 1 Phase, 50Hz and sized to maintain the motor internal temperature above dew point when the motor is idle. The minimum cable size for space heater shall be 2.5 sq.mm copper cable.

5.2 DELETED

5.3 INDICATOR/ SWITCH

5.3.1 Dial type local indicator with alarm contacts shall be provided for the following:

Hot and cold air temperature of the closed air circuit for CACA motor.

5.3.2 Alarm switch contact rating shall be minimum 2.0 A at 220V D.C. and 10A at 240V A.C.

5.4 ACCESSORY TERMINAL BOX

5.4.1 All accessory equipment such as space heater, temperature detector, current transformers etc., shall be wired to and terminated in terminal boxes, separate from and independent of motor (power) terminal box.

5.4.2 Accessory terminal box shall be complete with double compression brass glands and pressure type terminals to suit owner's cable connections.

DRAIN PLUG



**5 x 800 MW YADRADRI TPS
BASIC TECHNICAL FEATURES
FOR LT MOTORS
(FOR BHEL-PEM SCOPE PACKAGES)**

Doc. No.	PE-DC-417-565-E003
Rev. No.	02
Dated	16-08-2018
Page	7 of 7

Motor shall have drain plugs so located that they will drain the water, resulting from the condensation or other causes from all pockets of the motor casing.

5.5 LIFTING PROVISIONS

Motor weighing 25 Kg. or more shall be provided with eyebolt or other adequate provision of lifting.

5.6 DOWEL PINS

The motor shall be designed to permit easy access for drilling holes through motor feet or mounting flange for installation of dowel pins after assembling the motor and driven equipment.

7.0 PAINTING

Colour scheme for motors shall be shade 631 of IS-5.

8.0 TESTING

8.1 Type Tests

For LT Motors, type test reports for type tests as per IS: 12615/ IEC: 60034 conducted on equipment similar to those proposed to be supplied shall be submitted. The type Test should have been conducted within last 5 years from enquiry date.

8.2 Routine Tests

All motors shall be subjected to routine tests as per IS: 12615/ IEC: 60034 in the presence of customer or customer representative.

9.0 Variable Frequency Drive motor details:

- i) The motor shall be suitable for operation with a solid-state power supply consisting of an adjustable frequency inverter for speed control.
- ii) The motor shall be suitable for the current waveforms produced by the power supply including the harmonics generated by the drive.
- iii) The Motor shall be designed to operate continuously at any speed over the range 20-100 % of rated speed.
- iv) The permitted voltage variation should take into account the steady state voltage drop across the AC drive and all other system components upstream of the motor.
- v) Motors required to be transferred to DOL, by-pass mode shall be rated for specified variations in system line voltage and frequency. Starting current of motor in DOL, bypass mode shall be limited to value in motor specifications.
- vi) The motor shall be constructed to withstand torque pulsations resulting from harmonics generated by the solid-state power supply.
- vii) The motor insulation shall be designed to accept the applied voltage waveform, within the V_{peak} and dv/dt limits as per IEC-61800-4.
- viii) The drive manufacturer shall be solely responsible for proper selection of the motor for the given load application and the output characteristics of the drive.

LOAD TITLE	RATING (KW / A)		UNIT (U)/STN (S)	Nos.		VOLTAGE CODE*	FEEDER CODE**	EMER. LOAD (Y)	CONT.(C)/ INTT.(I)	STARTING TIME >5 SEC (Y)	LOCATION	BOARD NO.	CABLE		BLOCK CABLE DRG. No.	CONT ROL CODE	REMA RKS	LOAD No.	VERIFICATI ON FROM MOTOR DATASHEE T (Y/N)	KKS NO
	NAME PLATE	MAX. CONT. DEMAND (MCR)		RUNNING	STANDBY								SIZE CODE	NOs						
12		3	4	5	6	7	8	9	10	11	12	13	14	15	16	17	18	19	20 21	

ANNEXURE-II

NOTES: 1. COLUMN 1 TO 12 & 18 SHALL BE FILLED BY THE REQUISITIONER (ORIGINATING AGENCY); REMAINING COLUMNS ARE TO BE FILLED UP BY PEM (ELECTRICAL)/ CUSTOMER
2. ABBREVIATIONS : * VOLTAGE CODE (7):- (ac) A=11 KV, B=6.6 KV, C=3.3 KV, D=415 V, E=240 V (1 PH), F=110 V (cc): G=220 V, H=110 V, J=48 V, K=+24V, L=-24 V
: ** FEEDER CODE (8):- U=UNIDIRECTIONAL STARTER, B=BI-DIRECTIONAL STARTER, S=SUPPLY FEEDER, D=SUPPLY FEEDER (CONTACTER CONTROLLED)

LOAD DATA (ELECTRICAL)	JOB NO.	417	ORIGINATING AGENCY		PEM (ELECTRICAL)	
	PROJECT TITLE	5X800MW YADADRI TPS	NAME	DATA FILLED UP ON		
	SYSTEM	VENTILATION SYSTEM	SIGN.	DATA ENTERED ON		
	DEPTT. / SECTION	MAUX	SHEET 1 OF 1	REV. 00	DE'S SIGN. & DATE	



TITLE

LV MOTORS**DATA SHEET-A**

SPECIFICATION NO.

VOLUME II B

SECTION C

REV NO. 00 DATE 19.01.2018

SHEET 1 OF 1

- 1.0 Design ambient temperature : 50 °C
- 2.0 Maximum acceptable kW rating of LV motor : Above 0.2 kW & below 175 kW will be fed from 415V, however as per system requirement drives rated in the range of 160-210 kW may be considered in either 415V or 3.3. kV with due approval from BHEL/TSGENCO
- 3.0 Installation (Indoors/ Outdoors) : As required
- 4.0 Degree Of Protection : IP55
- 5.0 Details of supply system
- a) Rated voltage (with variation) : 240V, 415V \pm 10%
 - b) Rated frequency (with variation) : 50 Hz (Variation: +3% TO -5%)
 - c) Combined voltage & freq. variation : 10% (sum of absolute values)
 - d) System fault level at rated voltage : 50 kA for 1 sec
 - e) Short time rating for terminal box : 50 kA for 0.25 sec
 - f) LV System grounding : Solidly
- 6.0 Class of insulation : Class 'F', with temp rise limited to class B.
- 7.0 Minimum voltage for starting : 80% of rated voltage
(As percentage of rated voltage)
- 8.0 Power cables data : Shall be given during detailed engg.
- 9.0 Earth Conductor Size & Material : Shall be given during detailed engg.
- 10.0 Space heater supply (30KW & ABOVE) : 240 V, 1 Φ , 50 Hz
- 11.0 Rating up to which Single phase motor : Acceptable below 0.20 Kw
- 12.0 TYPE OF STARTER PROVIDED IN MCC : DOL
- 13.0 Locked rotor current
- a) Limit as percentage of FLC : As per IS-12615
 - b) Permissible tolerance, if any : As per IS-12615
- 14.0 Terminal box : Suitable to rotate at 90 degrees
- 15.0 Paint shade : Shade 631 of IS-5

	TITLE	<p style="text-align: center;">MOTOR DATA SHEET – C 5 X 800 MW YADADRI TPS</p>	SPECIFICATION NO.
			VOLUME II B
			SECTION D
			REV NO. 00 DATE
			SHEET 1 OF 2

S. No.	Description	Data to be filled by successful bidder
A.	General	
1	Manufacturer & country of origin	
2	Motor type	
3	Type of starting	
4	Name of the equipment driven by motor & Quantity	
5	Maximum Power requirement of driven equipment	
6	Rated speed of Driven Equipment	
7	Design ambient temperature	
B.	Design and Performance Data	
1	Frame size & type designation	
2	Type of duty	
3	Rated Voltage	
4	Permissible variation for	
5	a) Voltage	
6	b) Frequency	
7	c) Combined voltage & frequency	
8	Rated output at design ambient temp (by resistance method)	
9	Synchronous speed & Rated slip	
10	Minimum permissible starting voltage	
11	Starting time in sec with mechanism coupled	
12	a) At rated voltage	
13	b) At min starting voltage	
14	Locked rotor current as percentage of FLC (including IS tolerance)	
15	Torque	
	a) Starting	
	b) Maximum	
16	Permissible temp rise at rated output over ambient temp & method	
17	Noise level at 1.0 m (dB)	
18	Amplitude of vibration	
19	Efficiency & P.F. at rated voltage & frequency	
	a) At 100% load	
	c) At 75% load	

NAME OF VENDOR			SEAL	REV.	
NAME	SIGNATURE	DATE			

	TITLE	MOTOR DATA SHEET – C 5 X 800 MW YADADRI TPS		SPECIFICATION NO.
		VOLUME	II B	
		SECTION D		
		REV NO. 00	DATE	
		SHEET	2	OF 2

S. No.	Description	Data to be filled by successful bidder
	c) At starting	
C.	Constructional Features	
1	Method of connection of motor driven equipment	
2	Applicable Standard	
3	DOP of Enclosure	
4	Method of cooling	
5	Class of insulation	
6	Main terminal box	
	a) Type	
	b) Power Cable details (Conductor, size, armour/unarmour)	
	c) Cable Gland & lugs details (Size, type & material)	
	d) Permissible Fault level (kArms & duration in sec)	
7	Space heater details (Voltage & watts)	
8	Flame proof motor details (if applicable)	
	a) Enclosure	
	b) suitability for hazardous area	
	i Zone	O / I / II
	ii Group	IIA / IIB / IIC
9	No. of Stator winding	
10	Winding connection	
11	Kind of rotor winding	
12	Kind of bearings	
13	Direction of rotation when viewed from NDE	
14	Paint Shade & type	
15	Net weight of motor	
16	Outline mounting drawing No (To be enclosed as annexure)	
D.	Characteristic curves/ drawings (To be enclosed for motors of rating $\geq 55KW$)	
	a) Torque speed characteristic	
	b) Thermal withstand characteristic	
	c) Current vs time	
	d) Speed vs time	

NAME OF VENDOR			SEAL	REV.	
NAME	SIGNATURE	DATE			

Explanatory notes for filling up cable list for routing through WinPath, the cable routing program (developed by Corporate R&D) being used in PEM.

1. For the purpose of clarity, it may please be noted that the information given in regard to the cables to be routed through WinPath as per the system elaborated below is called "Cable List", while the term "Cable Schedule" applies to the cable list with routing information added after routing has been carried out.
2. The cable list shall be entered as an MS Excel file in the format as per enclosed template EXT_CAB_SCH_FORMAT.XLS. No blank lines, special characters, header, footer, lines, etc. shall be introduced in the file. No changes shall be made in the title line (first line) of the template.
3. The field properties shall be as under:
 - a. UNITCABLENO: A/N, up to sixteen (16) characters; each cable shall have its own unique, unduplicated cable number. In case this rule is violated, the cable cannot be taken up for routing.
 - b. FROM: A/N, up to sixty (60) characters; the "From" end equipment/ device description and location to be specified here. Information in excess of 60 characters will be truncated after 60 characters.
 - c. TO: A/N, up to sixty (60) characters; the "To" end equipment/ device description and location to be specified here. Information in excess of 60 characters will be truncated after 60 characters.
 - d. PURPOSE: A/N, up to sixty (60) characters; the purpose (i.e. power cable/ indication/ measurement, etc.) to be specified here. Information in excess of 60 characters will be truncated after 60 characters.
 - e. REMARKS: A/N, up to forty (40) characters; Any information pertinent to routing to be specified here (e.g., cable number of the cable redundant to the cable number being entered). Information in excess of 40 characters will be truncated after 40 characters.
 - f. CABLESIZE: A/N, 7 characters exactly as per the codes indicated below shall be specified here. The program cannot route cables described in any other way/ format.
 - g. PATHCABLENO: Field reserved for utilization by the program. User shall not enter any information here.
4. One list shall be prepared for each system/ equipment (i.e., separate and unique cable lists shall be prepared for each system).
5. The cables shall be described as per the scheme listed below:

A	NN	A	NNN
Cable	No. of cores	Cable code	Cable size
Voltage	(e.g. 01,03,3H, 07)	(See C below)	(e.g. 035,185,2.5, 0.5)
Code (see B below)			

(A) SYSTEM VOLTAGE CODES:

(ac) A = 11KV, B = 6.6KV, C = 3.3KV, D = 415V, E = 240V, F = 110V
 (dc) G = 220V, H = 110V, J = 48V, K = +24V, L = -24V

(B) CABLE VOLTAGE CODES:

A = 11KV (Power cables)

Explanatory notes for filling up cable list for routing through WinPath, the cable routing program (developed by Corporate R&D) being used in PEM.

- B = 6.6KV (Power cables)
- C = 3.3KV (Power cables)
- D = 1.1KV (LV & DC system power & control cables)
- E = 0.6KV (0.5 sq. mm. Control cables)

(C) CABLE CODES

PVC Copper

- A = Armoured FRLS
- B = Armoured Non-FRLS
- C = unarmoured FRLS
- D = Unarmoured Non-FRLS

PVC Aluminium

- E = Armoured FRLS
- F = Armoured Non-FRLS
- G = unarmoured FRLS
- H = Unarmoured Non-FRLS

XLPE Copper

- J = Armoured FRLS
- K = Armoured Non-FRLS
- L = unarmoured FRLS
- M = Unarmoured Non-FRLS

XLPE Aluminium

- N = Armoured FRLS
- P = Armoured Non-FRLS
- Q = unarmoured FRLS
- R = Unarmoured Non-FRLS

- S = FIRE SURVIVAL CABLES
- T = TOUGH RUBBER SHEATH
- U = OVERALL SCREENED
- V = PAIRED OVERALL SCREENED
- W = PAIRED INDIVIDUAL SCREENED
- Y = COMPENSATING CABLES
- I = PRE-FABRICATED CABLES
- Z = JELLY FILLED CABLES

6. Once a cable list has been given to PEM for routing, any subsequent changes required in the cable list (which may be in the form of addition of cables, deletion of cables, change of type or size of cable, etc.) must be informed as specific changes (as a separate file MS Excel of the same format as the original file) to the cable list given earlier if the cable list has been routed and cable schedule generated. The routing status of the cable list shall be got confirmed from PEM by the agency that has prepared the cable list before the changes are intimated. In case PEM confirms that the cable list in question has not been taken up for routing, and the revised cable list is acceptable, the same may be sent. Since cable routing through the program involves adding each cable list to the project cable schedule database, the original cable schedule shall not be furnished to PEM with revisions incorporated within.



**TECHNICAL SPECIFICATION
FOR VENTILATION SYSTEM
5X800 MW YADADRI TPS**

DOCUMENT NO.: PE-TS-417-554-A002

REVISION 00

DATE: AUG 2022

**SECTION: I
SUB-SECTION: E
ANNEXURE-I
LIST OF MAKES OF SUB-VENDOR ITEMS**

Customer approved makes

ANNEXURE

Yadadri TPS (5X800MW) approved sub vendor list

Lr.No.CE/TPC/SE-3/EME-11/YTPS(5X800MW)/F.Vendors/D.No. 59/21,Dt: 20.07.2021

Sl. No.	Item Description	Sl. No.	Proposed sub vendor for approval	TSGENCO remarks for YTPS (5X800MW)
9	AIR FILTER	1	FMI, KOLKATA	Approved
		2	ANFILCO, NEW DELHI	Approved
		3	TENACITY, PUNE	Approved
		4	JOHN FOWLER , BANGALORE	Approved
		5	SPECTRUM, KOLKATA	Approved
		6	AIR TECH, VASAI	Approved
		7	PUROMATIC, OKHLA	Approved
		8	PARKET HANNFFINS, BANGALORE	Approved
10	AXIAL FANS / F.A. FANS	1	FLAKT, GREATER NOIDA	Approved
		2	KHAITAN, KOLKATA	Approved
		3	PATEL AIR, AHMEDABAD	Approved

CHIEF ENGINEER/TPC

ANNEXURE

Yadadri TPS (5X800MW) approved sub vendor list for Air Conditioning System

Lr.No.CE/TPC/SE-3/EME-11/YTPS(5X800MW)/F.Vendors/D.No. 59/21, Dt: 20.07.2021

Sl. No.	Item Description	Sl. No.	Proposed sub vendor for approval	TSGENCO remarks for YTPS (5X800MW)
	AXIAL FANS / F.A. FANS	4	KRUGER , SINGAPORE/ THANE	Approved
		5	MARATHON , KOLKATA	Approved
		6	CB DOCTOR, AHMEDABAD	Approved
		7	ALMONARD, CHENNAI	Approved
		8	TCF NADI, CHENNAI	Approved
		9.	AVPL, Delhi	Approved
	10.	SK Systems, Delhi	Approved	

29	PROPELLAR FAN	1	CROMPTON, MUMBAI	Approved
		2	KHAITAN, KOLKATA	Approved
30	PR./DP. SWITCH	1	SIEMENS, GERMANY	Approved

ANNEXURE

Yadadri TPS (5X800MW) approved sub vendor list for Air Conditioning System

Lr.No.CE/TPC/SE-3/EME-11/YTPS(5X800MW)/F.Vendors/D.No. 59/21,Dt:20.07.2021

PART-I

Sl. No.	Item Description	Sl. No.	Vendor proposed for approval	TSGENCO Remarks for YTPS (5X800MW)
4	LT MOTORS	1	ABB LTD, SECUNDERABAD	Approved
		2	BHARAT BIJLEE LIMITED, MUMBAI	Approved

CHIEF ENGINEER/TPC

ANNEXURE

Yadadri TPS (5X800MW) approved sub vendor list for Air Conditioning System

Lr.No.CE/TPC/SE-3/EME-11/YTPS(5X800MW)/F.Vendors/D.No.59/21,Dt:20.07.2021

Sl. No.	Item Description	Sl. No.	Vendor proposed for approval	TSGENCO Remarks for YTPS (5X800MW)
		3	CG POWER & INDUSTRIAL SOLUTIONS LTD, AHMEDNAGAR	Approved
		4	CROMPTON GREAVES LTD., AHMEDNAGAR	Approved
	LT MOTORS	5	KIRLOSKAR ELECTRIC CO LTD., BANGALORE	Approved
		6	LAXMI HYDRAULICS PVT LTD., SECUNDERABAD	Approved
		7	SIEMENS INDIA LTD., CHENNAI	Approved
		8	MARATHON	Approved

Note :

The above sub vendor list is approved by customer .Bidder is suggested to consider above approved list for its offer.

However, Bidder can also propose any other make in its offer . The make approval shall be subjected to customer approval.

Bidder to mention its offered make in format enclosed at Section II Sub section 2 -LIST OF DOCUMENTS TO BE SUBMITTED WITH BID .

BHEL APPROVED LIST

SUB-VENDOR LIST FOR ELECTRICAL ITEMS

ITEM DESCRIPTION	SL NO.	VENDOR NAME
CABLE GLANDS	1	ALLIED TRADERS & EXPORTERS
	2	ARUP ENGG & FOUNDRY WORKS
	3	BALIGA LIGHTING EQPT.PVT.LTD.
	4	COMMET BRASS PRODUCTS
	5	DOWELLS
	6	ELECTROMAC INDUSTRIES
	7	INCAB
CABLE LUGS	1	DOWELLS
	2	UNIVERSAL MACHINES LTD.

Inspection Categorisation

Annexure-I

SL. NO.	DESCRIPTION OF THE EQUIPMENT	CATEGORY FURNISHED BY BHEL	INSPECTION CATEGORY APPROVED BY TSGENCO
1	Air washer & UAF	I	I
2	Centrifugal Fans	I	I
3	Horizontal Centrifugal Pumps (>75 KW)	II	I
4	Horizontal Centrifugal Pumps (<=75 KW)	II	II
5	LT Motors(= <55KW)	III	III
6	LT Motors(>55KW)	II	II
7	Axial Fan/RE fans/Propeller fan	III	III
8	Butterfly Valves	III	III
9	Conventional Gate/Globe/Check Valve	III	III
10	GM Gate/Globe/Check Valve	III	III
11	Filters (Pre filter & Fine Filter)	III	III
12	Pipe	III	III
13	Pipe fittings	III	III
14	Pr./Dp Gauges	III	III
15	Temperature Gauge	III	III
16	Transmitter	III	II
17	Temp /RH Sensor	III	II
18	Flow Indicator	III	III
19	GI sheet for ducting	III	III
20	Nozzles	III	III
22	Pr./DP.switch	III	III
23	Fire Damper (motorized)with single phase Actuator	III	II
24	Chain Pulley block	III	III
25	Junction Box	III	II
26	Cable Tray (upto 50mm)	III	III
27	Local Control Panel	II	I
28	Insulation Material	III	III
29	Level Gauge	III	III
30	Level Switch	III	III
31	Pot Strainer	III	III
32	Humidistat	III	III
33	Level Indicator	III	III
34	Instrument Fittings	III	III
35	Paint	III	III
36	Grill/Volume control damper	III	II

NOTE:			
INSPECTION CATEGORY	QAP APPROVAL BY	INSPECTION BY	MDCC BY
I	CUSTOMER/ CONSULTANT	CUSTOMER/CONSULTANT/ CUSTOMER appointed TPIA (Final inspection including document review as per approved QAP)	TSGENCO
II	CUSTOMER/ CONSULTANT	BHEL or BHEL'S TPIA	TSGENCO on submission of TC/IR/documents.
III	BHEL	Testing by vendor s Quality dept. & TCs Shall be submitted to BHEL(*)	BHEL
(*) COC shall be submitted by M/s BHEL			
For the items/Equipments which are not covered in the above list, BHEL has to submit such items to TSGENCO for Approval.			



5X800 MW YADADRI TPS

**VENTILATION SYSTEM
MANDATORY SPARE LIST**

SPECIFICATION NO. PE-TS-417-554-A002

SECTION : I

SUB-SECTION : E

REV 00

DATE: AUG 2022

**SECTION-I
SUB SECTION -E**

ANNEXURE-II

**MANDATORY SPARE LIST
(Refer Annexure II of Price Schedule)**



**TECHNICAL SPECIFICATION
FOR VENTILATION SYSTEM
5X800 MW YADADRI TPS**

DOCUMENT NO.: PE-TS-417-554-A002

REVISION 00

DATE: AUG 2022

**SECTION: I
SUB-SECTION: E
ANNEXURE-III
PAINTING AND COLOUR SCHEME
(AS PER SECTION C2C)**



5X800 MW YADADRI TPS

**VENTILATION SYSTEM
LIST OF TOOLS & TACKLES**

SPECIFICATION No: PE-TS-417-554-A002

SECTION : I

SUB-SECTION : E

REV 00

DATE: AUG 2022

SHEET 1 OF 2

SECTION-I

SUB-SECTION-E

ANNEXURE-IV

LIST OF TOOLS & TACKLES

NAME OF PROJECT:		5X800 MW TSGENCO YADADRI TPS		
NAME OF PACKAGE:		VENTILATION SYSTEM		
TECHNICAL SPECIFICATION No:		PE-TS-417-554-A003		
SL NO	DESCRIPTION	UNIT		Stage # 2 Qty
1	Measuring tape	NO		1
2	Tachometer	NO		1
3	Double ended spanner	SET		1
4	Ring spanners	SET		1
5	Gasket punch	NO.		1
6	Center punch	NO.		1
7	Hammer with wooden handles	NO.		1
8	Scissors for sheet metal cutting	NO.		1
9	Torch light (suitable for 2 cells)	NO.		1
10	Multimeter	NO.		1
11	Anemometer	NO.		1
12	Compound pressure gauge	NO.		1
13	Slide wrench 8"	NO.		1
14	Slide wrench 10"	NO.		1
15	Slide wrench 6"	NO.		1
16	Box spanner set	SET		1
17	Screw driver set	SET		1
18	Align key set	SET		1
19	MS tool box	NO		1
1				
NOTES				
1	ABOVE IS THE MINIMUM LIST. ANY OTHER TOOL / TACKEL REQUIRED FOR THE SYSTEM SHALL ALSO BE PROVIDED BY THE VENDOR WITHOUT ANY COST IMPLICATION.			



5X800 MW YADADRI

VENTILATION SYSTEM
DRAWINGS / DOCUMENTS SUBMISSION
PROCEDURE

SPECIFICATION No: PE-TS-417-554 -A002

SECTION : I

SUB-SECTION : E

REV 00

DATE: AUG 2022

SHEET 1 OF 2

SECTION-I

SUB-SECTION-E

ANNEXURE-VI

DRAWINGS / DOCUMENTS SUBMISSION PROCEDURE

(AS PER SECTION C2B)



5X800 MW YADADRI TPS

SPECIFICATION No: PE-TS-425-554-A001

SECTION : I

SUB-SECTION : E

REV 00

DATE: APR 2020

SHEET 1

VENTILATION SYSTEM
FORMAT FOR OPERATION AND
MAINTENANCE MANUAL

SECTION-I

SUB-SECTION-E

ANNEXURE-IX

**FORMAT FOR OPERATION AND MAINTENANCE
MANUAL**



5X800 MW YADADRI TPS

SPECIFICATION No: PE-TS-425-554-A001

SECTION : I

SUB-SECTION : E

REV 00

DATE: APR 2020

SHEET 2

**VENTILATION SYSTEM
FORMAT FOR OPERATION AND
MAINTENANCE MANUAL**

Project name :
Project number :
Package Name :
PO reference :
Document number :
Revision number :

Sl.no. & Sections	Description	Tick (√)if included in Manual			Remarks
		Yes	No	Not Applicable	
1.	COVER PAGE				
1.1	Project Name				
1.2	Customer/consultant Name				
1.3	Name of Package				
1.4	Supplier details with phone, FAX ,email address , Emergency Contact number				
1.5	Name and sign of prepared by , checked by & approved by				
1.6	Revision history with approval Details				
2.0	INDEX				
2.1	showing the sections & related page nos All the pages should be numbered section wise				
3.0	DESCRIPTION OF PLANT/SYSTEM				
3.1	Description /write up of operating principle of system equipment/ associated sub-systems & accessories/controls system , operating conditions, performance parameters under normal , start up and special cases				
3.2	Equipment list and basic parameter with Tag numbers				
3.3	Data sheets approved by Customer/for information and catalogues provided by original manufacturer				
3.4	Associated other packages and Interface /terminal points				
3.5	P&ID & Process Diagrams				
3.6	GA Layout drawings, As-built drawings , Actual photograph of items/system (Drawings of A2 & bigger sizes are to be attached in the last)				
3.7	Single line/wiring diagrams				
3.8	Control philosophy /control write-ups				



5X800 MW YADADRI TPS

SPECIFICATION No: PE-TS-425-554-A001

SECTION : I

SUB-SECTION : E

REV 00

DATE: APR 2020

**VENTILATION SYSTEM
FORMAT FOR OPERATION AND
MAINTENANCE MANUAL**

SHEET 3

Sl.no. & Sections	Description	Tick (√)if included in Manual			Remarks
		Yes	No	Not Applicable	
4.0	COMMISSIONING ACTIVITIES (IF NOT COVERED IN SEPARATE DOCUMENT I.E. ERECTION MANUAL, COMMISSIONING MANUAL)				
4.1	Pre-Commissioning Checks				
4.2	handling of items at site				
4.3	Storage at site				
4.4	Unpacking & Installation procedure				
5.0	OPERATION GUIDELINES FOR PLANT PERSONAL/USER/OPERATOR				
5.1	Interlock & Protection logic along with the limiting values of protection settings for the equipment along with brief philosophy behind the logic, drawings etc. to be provided.				
5.2	Start up, normal operation and shut down procedure for equipments along with the associated systems in step by step mode. Valve sequence chart, step list, interlocks etc. with Equipment isolating procedures to be mentioned.				
5.3	Do's & Don't of the equipments.				
5.4	Safety precautions to be taken during normal operation. Safety symbols, Emergency instructions on total power failure condition/lubrication failure/any other condition				
5.5	Parameters to be monitored with normal values and limiting values				
5.6	Trouble shooting with causes and remedial measures				
5.7	Routine operational checks, recommended logs & records				
5.8	Changeover schedule if more than one auxiliary for the same purpose is given				
5.9	Painting requirement and schedule				
5.10	Inspection, repair , Testing and calibration procedures				
6.0	MAINTENANCE GUIDELINES FOR PLANT PERSONAL				



5X800 MW YADADRI TPS

SPECIFICATION No: PE-TS-425-554-A001

SECTION : I

SUB-SECTION : E

REV 00

DATE: APR 2020

**VENTILATION SYSTEM
FORMAT FOR OPERATION AND
MAINTENANCE MANUAL**

SHEET 4

Sl.no. & Sections	Description	Tick (✓)if included in Manual			Remarks
		Yes	No	Not Applicable	
6.1	List of Special Tools and Tackles required for Overhaul/Trouble shooting including special testing equipment required for calibration etc.				
6.2	Stepwise dismantling and re-assembly procedure clearly specifying the tools to be used, checks to be made, records to be maintained, clearances etc. to be mentioned. Tolerances for fitment of various components to be given.				
6.3	Preventive Maintenance & Overhauling schedules linked with running hours/calendar period along with checks to be given				
6.4	Long term maintenance schedules especially for structural, foundations etc.				
6.5	Consumable list along with the estimated quantity required during commissioning, normal running and during maintenance like Preventive Maintenances and Overhaul. Storage/handling requirement of consumables/self-life.				
6.6	List of lubricants with their Indian equivalent, Lubrication Schedule, Quantity required for each equipment for complete replacement is to be given				
6.7	List of vendors & Sub-vendors with their latest addresses, service centres ,Telephone Nos., Fax Nos., Mobile Nos., e-mail IDs etc.				
6.8	List of mandatory and recommended spare parts list				
6.9	Tentative Lead time required for ordering of spares from the equipment supplier				
6.10	Guarantee and warranty clauses				
7.0	Statutory and other specific requirements considerations.				
8.0	List of reference documents				
9.0	Binding as per requirement				



5X800 MW YADADRI TPS

**VENTILATION SYSTEM
SITE STORAGE AND PRESERVATION**

SPECIFICATION No: PE-TS-417-554-A002

SECTION : I

SUB-SECTION : E

REV 00

DATE: AUG 2022

SHEET

SECTION-I
SUB-SECTION-E
ANNEXURE-IX
SITE STORAGE AND PRESERVATION

SITE STORAGE AND PRESERVATION GUIDELINES FOR MECHNANICAL BOPs

(Doc No: PE-DC-SSG-A001 REV.00)



PROJECT ENGINEERING MANAGEMENT, POWER SECTOR
BHARAT HEAVY ELECTRICALS LIMITED-NOIDA

CONTENT

- 1 SCOPE OF THE DOCUMENT
- 2 PURPOSE OF STORAGE & PRESERVATION
- 3 MEASURES TO BE TAKEN FOR STORAGE AND PRESERVATION
 - a) GENERAL STORAGE REQUIREMENTS
 - b) GENERAL PRESERVATION REQUIREMENTS
 - c) GENERAL INSPECTION REQUIREMENTS
- 4 TYPE OF STORAGE FOR VARIOUS EQUIPMENT
5. CONCLUSION
6. STACKING ARRANGEMENT FOR PLATES AND STRUCTURAL STEEL

1. SCOPE OF THE DOCUMENT

This guideline is prepared in intent to provide proper site storage and preservation of the Mechanical, Electrical and C & I items / equipment supplied under various bought out packages/items. This storage procedure shall be followed at different power plant sites by concerned agency for storage and preservation from the date of equipment received at site until the same are erected and handed over to the customer.

2. PURPOSE OF STORAGE & PRESERVATION

Many of the items may be required to be kept in stores for long period. It shall therefore be essential that proper methods of storage and preservation be applied so that items do not deteriorate, loose some of their properties and become unusable due to atmospheric conditions and biological elements.

3. MEASURES TO BE TAKEN FOR STORAGE, HANDLING & PRESERVATION

a) GENERAL STORAGE REQUIREMENTS

1. To the extent feasible, materials should be stored near the point of erection. The storage areas should have adequate unloading and handling facilities with adequate passage space for movement of material handling equipment such as cranes, fork lift trucks, etc. The storage of materials shall be properly planned to minimise time loss during retrieval of items required for erection.
2. The outdoor storage areas as well as semi-closed stores shall be provided with adequate drainage facilities to prevent water logging. Adequacy of these facilities shall be checked prior to monsoon.
3. The storage sheds shall be built in conformity with fire safety requirements. The stores shall be provided with adequate lights and fire extinguishers. 'No smoking' signs shall be placed at strategic locations. Safety precautions shall be strictly enforced.
4. Adequate lighting facility shall be provided in storage areas and storage sheds and security personnel positioned to ensure enforcement of security measures to prevent theft and loss of materials.
5. Adequate number of competent stores personnel and security staff shall be deployed to efficiently store and maintain the equipment / material.
7. The equipment shall be stored in an orderly manner, preserving their identification slips, tags and instruction booklets, etc., required during erection. The storage of materials shall be equipment-wise. Loose parts shall be stored in sheds on racks,

preserving the identification marks and tags in good condition. The group codes shall be displayed on the racks

6. At no time shall any materials be stored directly on ground. All materials shall be stored minimum 200 mm above the ground preferably on wooden sleepers

b) GENERAL PRESERVATION REQUIREMENTS

1. All special measures to prevent corrosion shall be taken like keeping material in dry condition, avoiding the equipment coming in contact with corrosive fluid like water, acid etc.
2. Materials which carry protective coating shall not be wrapped in paper, cloth, etc., as these are liable to absorb and retain moisture. The material shall be inspected and in case of signs of wear or damages to protective coating, that portion shall be cleaned with approved solution and coated with an approved protective paint. Complete record of all such observations and protective measures taken shall be maintained.
3. Generally equipment supplied at site are properly greased or rust protective oil is applied on machined/ fabricated components. However periodic inspection shall be carried out to ensure that protection offered is intact.
4. While handling the equipment, no dragging on the ground is permitted. Avoid using wire rope for lifting coated components. Use polyester slings (if possible) otherwise protective material (e.g. clothes, wood block etc.) should be used while handling the components with rope / slings
5. For Equipment supplied with finished paint, touch paint shall be done in case any surface paint gets peeled off during handling. Otherwise such surfaces shall necessarily be wrapped with polythene to avoid any corrosion. Further for equipment wherein finish coat is to be applied at site, site to ensure that equipment is received with primer coat applied.
6. It shall be ensured by periodic inspection that plastic inserts are intact in tapped holes, wherever applicable.
7. Pipes shall be blown with air periodically and it shall be ensured that there is no obstruction.
8. Silica gel or approved equivalent moisture absorbing material in small cotton bags shall be placed and tied at various points on the equipment, wherever necessary.
9. Heavy rotating parts in assembled conditions shall be periodically rotated to prevent corrosion/jamming due to prolonged storage.

10. All the electrical equipment such as motors, generators, etc. shall be tested for insulation resistance at least once in three months and a record of such measured insulation values shall be maintained.
11. Following preservatives/preservation methods can be used depending upon type of equipment
 - a. Rust preventive fluid (RPF)
 - b. Rust protective paints
 - c. Tarpaulin covers, in case of outdoor storage
 - d. De-oxy aluminate for weld-ments

c) GENERAL INSPECTION REQUIREMENTS

1. Period inspection of materials with specific reference to –
 - Ingress of moisture and corrosion damages.
 - Damage to protective coating.
 - Open ends in pipes, vessels and equipment -
 - In case any open ends are noticed, same shall be capped.
2. Any damages to equipment / materials.
 - In case of any damages, these shall be promptly notified and in all cases, the repairs / rectification shall be carried out.
 - Any items found damaged or not suitable as per project requirements shall be removed from site. If required to store temporarily, they shall be clearly marked and stored separately to prevent any inadvertent use.

4. TYPE OF STORAGE FOR VARIOUS EQUIPMENT

The types of storage are broadly classified under the following heads:

i **Closed storage with dry and dust free atmosphere. (C)**

The closed shed can be constructed by using cold-rolled / tubular components for structure and corrugated asbestos sheets / galvanised iron sheets for roofing. Brick walls / asbestos sheets can be used to cover all the sides. The floor of the shed can be finished with plain cement concrete suitably glazed. The shed shall be provided with proper ventilation and illumination.



ii **Semi-closed storage. (S)**

The semi closed shed can be constructed by using cold-rolled / tubular components for structure and corrugated / asbestos sheets for roofing. The floor shall be brick paved. If required a small portion of sides can be covered to protect components from rainwater splashing onto the components.





iii Open storage (O)

The open yard shall be levelled, well consolidated to achieve raised ground with the provision of feeder roads for crane approach along with access roads running all sides. One part of the open yard shall be stone pitched, levelled and consolidated with raised ground suitable for storing / stacking heavier and critical components with due space to handle them by cranes etc . Adequate number of sleepers, concrete block etc. to be provided to make raised platforms to stack critical materials.

A separate yard to be identified as “scrap yard” slightly away from main open yard to store wooden/steel scraps, which are to be disposed off. This is required to avoid mix up with regular components as well as to avoid fire hazard.

Some of the components, which are having both machined & un-machined surfaces and are bulky, shall be stored in open storage area on a raised ground and suitably covered with water proof / fire retardant tarpaulin.



The equipment listed below shall be stored and inspected as per requirement mentioned in the table below.

Sl. No.	Description of the equipment	Type of Storage	Check for	Remarks
Raw material /mechanical items like pipes, plates, structure sections etc.)				
1.	Steel pipes (lined/unlined)	S	Damage , paint, corrosion, rubber lining peeling	Provide end cap
2.	MS Plates	S	Damage, paint, corrosion	
3.	SS Plates	S	Damage	
4.	Non-metallic pipes	S	Damage, cracks	Provide end cap
5.	Stainless steel pipes	S	Damage ,	Provide end cap
6.	MS sections, beams	S	Damage, paint, corrosion	
7.	Cable trays	S	Damage, condition of preservations	
8.	Insulation sheets	S	Damage	
9.	Insulation	C	Damage, packing	
10.	Hangers Rods	S	Damage, paint, packing	
11.	Tubes	S	Damage, paint , packing	Provide end cap
12.	Hume pipes	O	Damage	
13.	Castings	O	Damage, paint, corrosion	
Fabricated mechanical items (pressure vessels, tanks etc.)				
14.	Pressure vessels (unlined)	O	Damage, paint, corrosion,	Covered nozzles
15.	Atmospheric storage tanks (unlined)	O	Damage, paint, corrosion	Covered nozzles

Sl. No.	Description of the equipment	Type of Storage	Check for	Remarks
16.	Pressure vessels (lined)	S	Damage, paint, corrosion, rubber lining	
17.	Atmospheric storage tanks(lined)	S	Damage, paint, corrosion, rubber lining	
18.	Support structures	O	Damage , paint, corrosion	
19.	Flanges	C	Damage , paint, corrosion	
20.	Fabricated pipes	S	Damage , paint, corrosion	Provide end cap
21.	Vessels internals	C	Damage , paint, corrosion ,packing	
22.	Grills	S	Damage , paint, corrosion	
23.	Angles	S	Damage , paint, corrosion	
24.	Bridge mechanism/clarifier mechanism	O	Damage , paint, corrosion	
25.	Cranes, rails	S	Damage , paint, corrosion	
26.	Stair cases	O	Damage , paint, corrosion	
27.	Ladders/handrails	O	Damage , paint, corrosion	
28.	Fabricated ducts	S	Damage , paint, corrosion	
29.	Isolation Gates	O	Damage , paint, corrosion	
30.	Fabricated boxes/panels	S	Damage , paint, corrosion	
Mechanical components like valves, fittings, cables glands, spares etc.)				
31.	Valves	S	Damage , packing	

Sl. No.	Description of the equipment	Type of Storage	Check for	Remarks
32.	Fittings	S	Damage , packing	Provide end cap
33.	Cable glands	C	Damage , packing	
34.	Tools & tackles	C	Damage , packing	
35.	Nut , bolts, washers,	C	Damage , packing	
36.	Gasket & Packings	C	Damage , packing	
37.	Copper tubes	C	Damage , packing, corrosion	Provide end cap
38.	SS tubing	C	Damage , packing	Provide end cap
Rotating assemblies (pumps, blowers, stirrers, fans, compressors etc.)				
39.	Pumps	S	Damage , packing, corrosion	Shaft rotation
40.	Blowers/Compressors	S	Damage , packing, corrosion	Shaft rotation
41.	Agitators/stirrers/radial launders	C	Damage , packing, corrosion	Shaft rotation
42.	Rollers for chlorine tonner mounting	C	Damage , packing, corrosion	
43.	Centrifuge	S	Damage , packing,	
44.	Gear box	C	Damage , packing, corrosion	
45.	Bearings	C	Damage , packing, corrosion	
46.	Fans	S	Damage , packing, corrosion	
47.	Dosing skids	S	Damage , packing, corrosion	
48.	Pump assemblies	S	Damage , packing, corrosion	
49.	Air washers(INTERNALS)	S	Damage , packing	
50.	Air conditioners (split)	C	Damage , packing	

Sl. No.	Description of the equipment	Type of Storage	Check for	Remarks
51.	Elevators(CONTAINERIZED)	O	Damage , packing, corrosion	
52.	Chillers/VA machines	S	Damage , packing	
53.	Air handling Unit/Package unit	S	Damage , packing	
54.	Chlorinators & Evaporators	C	Damage , packing	
55.	Ejectors	C	Damage , packing	
56.	Electrolyser	C	Damage , packing	
Miscellaneous items like chain pulley blocks, hoists etc.				
57.	Chain pulley blocks	S	Damage, Packing	
58.	Electric hoists	S	Damage, Packing	
59.	Fire extinguishers	C	Damage, expiry date	
60.	Fork Lift Truck	S	Damage, Packing	
61.	Hydraulic Mobile Crane	O	Damage, Packing	
62.	Mobile Pick Up & Carry Crane	O	Damage, Packing	
63.	Motor boats	O	Damage, Packing	
64.	Safety showers	S	Damage, Packing	
65.	Diffusers/dampers	S	Damage, Packing	
Chemicals and consumables (acid, alkali, paints, oils, reagents and special chemicals)				
66.	Hydro Chloric Acid (HCl)	Store in canes/ storage tank in dyke area	Date of production/ leakage/fumes	hazardous chemical
67.	Sulphuric acid (H ₂ SO ₄)	Store in canes/ storage tank in dyke area	Date of production/ leakage/fumes	hazardous chemical

Sl. No.	Description of the equipment	Type of Storage	Check for	Remarks
68.	Sodium hydroxide (NaOH)	Store in canes/ storage tank in dyke area	Date of production/ leakage/ fumes/ breather	hazardous chemical ,breather to be checked for air ingress
69.	Sodium hypo chlorite	To be stored under shed	Date of production/ leakage/ fumes	hazardous chemical ,self-life normally 15-30 days after which strength of chemical decays
70.	Ammonia	S	Date of production/ leakage/ fumes	Store in closed storage tanks, hazardous chemical
71.	CW treatment chemicals	S	Date of production , Self-life	Store in closed canes
72.	RO/UF cleaning chemicals	S	Date of production , Self-life	Store in closed canes
73.	Lime	C	Damage to packing , seepage	Prevent moisture, rain
74.	Alum bricks	C	Damage to packing	Prevent moisture, rain
75.	Poly electrolyte	S		Store in closed storage tanks
76.	Laboratory chemicals(powder)	C	Damage, Packing self- life	
77.	Laboratory chemicals(liquid)	C	Damage, Packing self- life	
78.	Lubrication oils	C	Leakage	
79.	Paints	S	Leakage ,air tightness	
80.	Sand	O	Damage of packing	No hooks
81.	Salt (NaCl)	C	Damage of packing, water ingress	Prevent moisture, rain
82.	Anthracite	S	Damage of packing	
83.	Activated carbon	S	Damage of packing	

Sl. No.	Description of the equipment	Type of Storage	Check for	Remarks
84.	Thermal insulation	S	Damage of packing	
85.	Cement	C	Damage of packing	Prevent moisture, rain
86.	Gravels	O	Damage of packing	
87.	ION exchange resins	C	Damage , packing	Refer manufacturer guidelines
88.	RO membranes	C	Damage , packing	Refer manufacturer guidelines
89.	UF membranes	C	Damage , packing	Refer manufacturer guidelines
90.	Cleaning chemicals	C	Damage , packing	Refer manufacturer guidelines
91.	Chemicals for analysers/calibration	C	Damage , packing	Refer manufacturer guidelines
Electrical and C & I items (motors, cables etc.)				
92.	Motors	C	Damage , packing	
93.	Cable drums	O	Damage	
94.	Control Panel /control desk, UPS ,JB	S	Damage, Packing	
95.	Instruments(gauges/analysers)	C	Damage	
Special items		As per Manufacturer's item, like Hydrogen cylinders, Ozonator, Analyser, Chlorine dioxide generators etc.		

5. CONCLUSION

Concerned storage agency at site should make sure that loss in equipment performance and wear & tear are minimised through proper storage and preservation. The above are broad guidelines and cover major equipment / materials. However specific storage practices shall be followed as per manufacturer recommendation. All the necessary measures even in addition to the ones mentioned above, if found necessary, should be taken to achieve the objective.

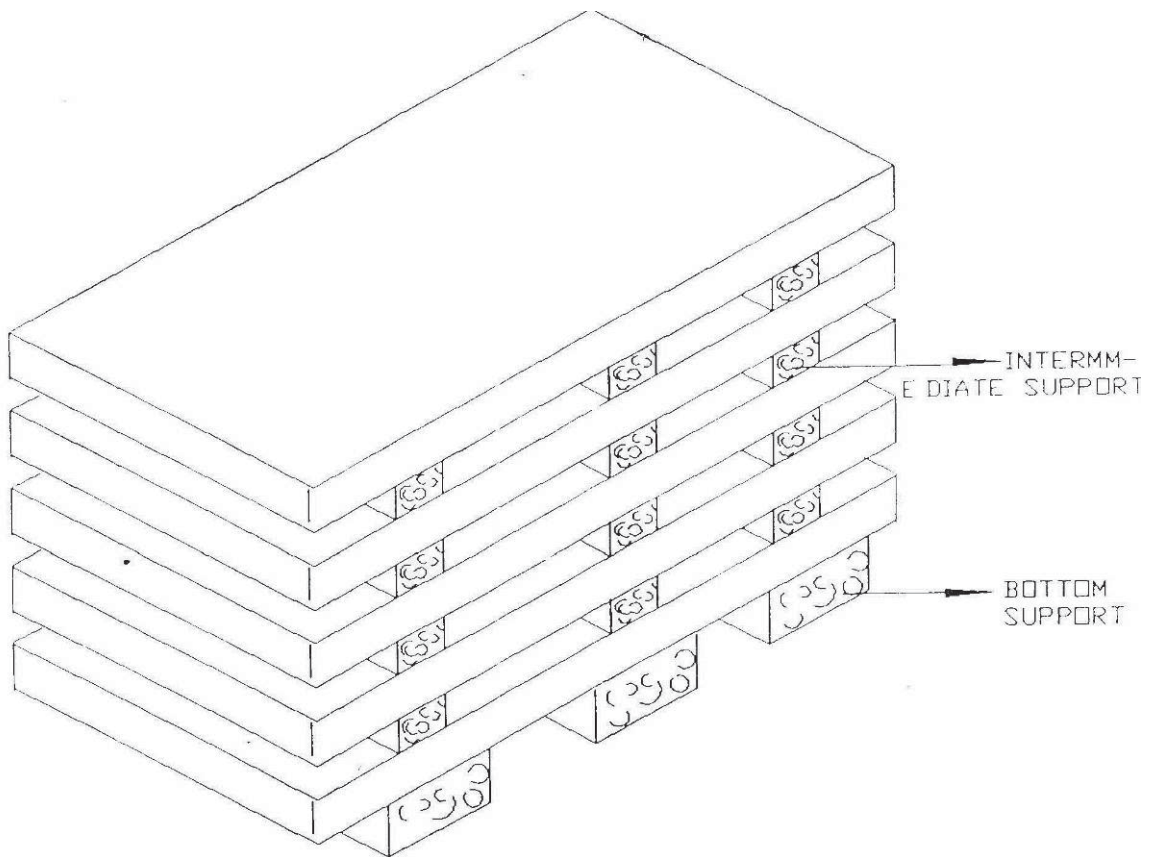

Figure - 1 - PLATE STACKING ARRANGEMENT

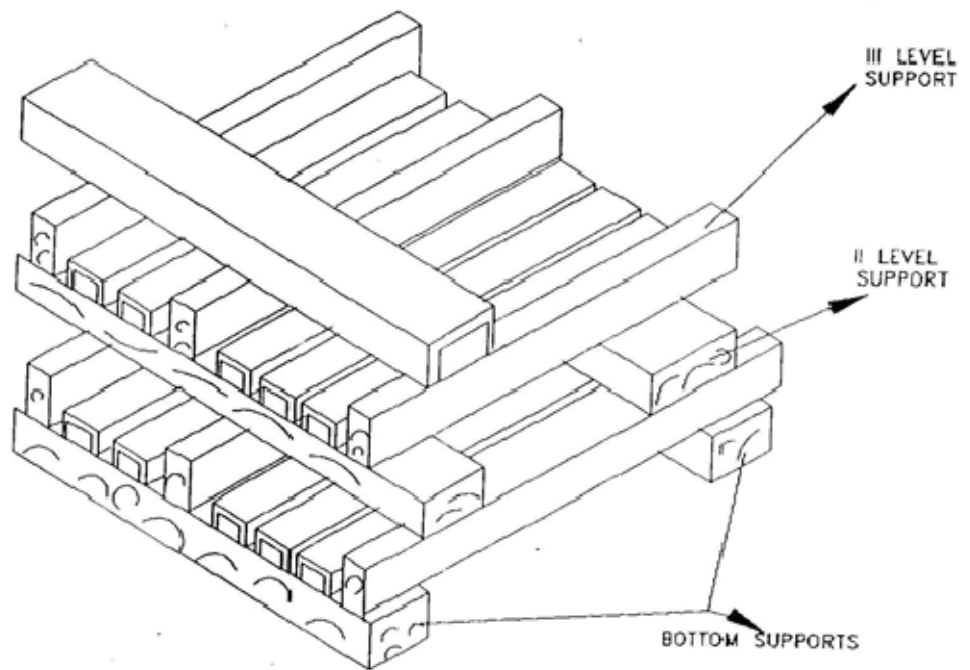

Figure - 2 - STRUCTURAL STEEL STACKING ARRANGEMENT



5X800 MW YADADRI TPS

VENTILATION SYSTEM

SPECIFICATION No: PE-TS-417-554-A002

SECTION: II

REV. 00

DATE: AUG 2022

SECTION II



5X800 MW YADADRI TPS

**VENTILATION SYSTEM
LIST OF DOCUMENTS TO BE SUBMITTED WITH
BID**

SPECIFICATION No: PE-TS-417-554-A003

SECTION : II

SUB-SECTION : 2

REV: 00

DATE: JUL 2023

SHEET 1 OF 1

BIDDER SHOULD SUBMIT THE SIGNED AND STAMPED COPY OF THE FOLLOWING DOCUMENTS:

1. Compliance cum confirmation certificate
2. Un priced format for main package, mandatory spare, Tools and Tackles, Commissioning spare. (mentioning quoted against each item)
3. Complete set of technical specification
4. No deviation certificate
5. **Make Declaration by Bidder(attached below at page 146)**
6. **Guarantee Power Consumption**



5X800 MW YADADRI TPS

SPECIFICATION No: PE-TS-417-554-A002

SECTION : II

**VENTILATION SYSTEM
COMPLIANCE CUM CONFIRMATION
CERTIFICATE**

SUB-SECTION : 3

REV. NO. 00

DATE: AUG 2022

SHEET: 1 OF 2

COMPLIANCE CUM CONFIRMATION CERTIFICATE

The bidder shall confirm compliance with following by signing / stamping this compliance certificate (every sheet) and furnish same with the offer.

- a) The scope of supply, technical details, construction features, design parameters etc. shall be as per technical specification & there are no exclusions, other than those mentioned under "exclusion and those resolved as per 'Schedule of Deviations', with regard to same.
- b) There are no other deviations w.r.t. specifications other than those furnished in the 'Schedule of Deviations'. Any other deviation, stated or implied, taken elsewhere in the offer stands withdrawn unless specifically brought out in the 'Schedule of Deviations'
- c) Bidder shall submit QP in the event of order based on the guidelines given in the specification & QP enclosed therein. QP will be subject to BHEL / CUSTOMER approval & customer hold points for inspection / testing shall be marked in the QP at the contract stage. Inspection / testing shall be witnessed as per same apart from review of various test certificates/ Inspection records etc. This is within the contracted price without any extra implications to BHEL after award of the contract.
- d) All drawings/ data-sheets / calculations etc. submitted along with the offer shall not be taken cognizance off.
- e) The offered materials shall be either equivalent or superior to those specified in the specification & shall meet the specified / intended duty requirements. In case the material specified in the specifications is not compatible for intended duty requirements then same shall be resolved by the bidder with BHEL during the pre-bid discussions, otherwise BHEL / Customer's decision shall be binding on the bidder whenever the deficiency is pointed out.

For components where materials are not specified, same shall be suitable for intended duty, all materials shall be subject to approval in the event of order.

- f) The commissioning spares shall be supplied on 'As Required Basis' & prices for same included in the base price itself.
- g) All sub vendors shall be subject to BHEL / CUSTOMER approval in the event of order.
- h) Guarantee for plant/equipment shall be as per relevant clause of GCC / SCC / Other Commercial Terms & Conditions
- i) In the event of order, all the material required for completing the job at site shall be supplied by the bidder within the ordered price even if the same are additional to approved billing break up, approved drawing or approved Bill of quantities within the scope of work as tender specification. This clause will apply in case during site commissioning, additional requirements emerges due to customer and / or consultant's comments. No extra claims shall be put on this account



5X800 MW YADADRI TPS

SPECIFICATION No: PE-TS-417-554-A002

SECTION : II

**VENTILATION SYSTEM
COMPLIANCE CUM CONFIRMATION
CERTIFICATE**

SUB-SECTION : 3

REV. NO. 00

DATE: AUG 2022

SHEET: 2 OF 2

- j) Schedule of drawings submissions, comment incorporations & approval shall be as stipulated in the specifications. The successful bidder shall depute his design personnel to BHEL's / Customer's / Consultant's office for across the table resolution of issues and to get documents approved in the stipulated time.
- k) As built drawings shall be submitted as and when required during the project execution.
- l) The bidder has not tempered with this compliance cum confirmation certificate and if at any stage any tempering in the signed copy of this document is noticed then same shall be treated as breach of contract and suitable actions shall be taken against the bidder.
- m) Successful bidder shall furnish detailed erection manual for each of the equipment supplied under this contract at least 3 months before the scheduled erection of the concerned equipment / component or along with supply of concerned equipment / component whichever is earlier.
- n) Document approval by customer under Approval category or information category shall not absolve the vendor of their contractual obligations of completing the work as per specification requirement. Any deviation from specified requirement shall be reported by the vendor in writing and require written approval. Unless any change in specified requirement has been brought out by the vendor during detail engineering in writing while submitting the document to customer for approval, approved document (with implicit deviation) will not be cited as a reason for not following the specification requirement.
- o) In case vendor submits revised drawing after approval of the corresponding drawing, any delay in approval of revised drawing shall be to vendor's account and shall not be used as a reason for extension in contract completion.



5X800 MW YADADRI TPS

VENTILATION SYSTEM
PRE-BID CLARIFICATION SCHEDULE

SPECIFICATION No: PE-TS-417-554-A002

SECTION : II

SUB-SECTION : 4

REV. NO. 00

DATE: AUG 2022

SHEET: 1 OF 1

PRE-BID CLARIFICATION SCHEDULE

S. NO.	SECTION/CLAUSE/PAGE NO.	STATEMENT OF THE REFERRED CLAUSE	CLARIFICATION REQUIRED

The bidder hereby clarifies that above mentioned are the only clarifications required on the technical specification for the subject package.

Signature: _____

Name: _____

Designation: _____

Company: _____

Date: _____

Company Seal

ANNEXURE-II: DEVIATION SHEET (COST OF WITHDRAWAL)

PROJECT:-
PACKAGE:-
TENDER ENQUIRY REFERENCE:-

NAME OF VENDOR:-

SL NO	VOLUME/ SECTION	PAGE NO.	CLAUSE NO.	TECHNICAL SPECIFICATION/ TENDER DOCUMENT	COMPLETE DESCRIPTION OF DEVIATION	COST OF WITHDRAWAL OF DEVIATION	REFERENCE OF PRICE SCHEDULE ON WHICH COST OF WITHDRAWAL OF DEVIATION IS APPLICABLE	NATURE OF COST OF WITHDRAWAL OF DEVIATION (POSITIVE/NEGATIVE)	REASON FOR QUOTING DEVIATION
TECHNICAL DEVIATIONS									
COMMERCIAL DEVIATIONS									
PARTICULARS OF BIDDERS' AUTHORISED REPRESENTATIVE									

NAME	DESIGNATIONS	SIGN & DATE

NOTES:

- Cost of withdrawal of deviation will be applicable on the basic price (i.e. excluding taxes, duties & freight) only.
- All the bidders have to list out all their Technical & Commercial Deviations (if any) in detail in the above format.
- Any deviation not mentioned above and shown separately or found hidden in offer, will not be taken cognizance of.
- Bidder shall submit duly filled unpriced copy of above format indicating "quoted" in "cost of withdrawal of deviation" column of the schedule above along with their Techno-commercial offer, wherever applicable. In the absence of same, such deviation(s) shall not be considered and offer shall be considered in total compliance to NIT.
- Bidder shall furnish price copy of above format along with price bid.
- The final decision of acceptance/rejection of the deviations quoted by the bidder shall be at discretion of the Purchaser.
- Bidders to note that any deviation (technical/commercial) not listed in above and asked after Part-I opening shall not be considered.
- For deviations wr.t. Credit Period, Liquidated damages, Firm prices if a bidder chooses not to give any cost of withdrawal of deviation (loading as per Annexure-VII), will apply. For any other deviation mentioned in un-priced copy of this format submitted with Part-I bid but not mentioned in priced copy of this format submitted with Priced bid, the cost of withdrawal of deviation shall be taken as NIL.
- Any deviation mentioned in priced copy of this format, but not mentioned in the un-priced copy, shall not be considered.
- All techno-commercial terms and conditions of NIT shall be deemed to have been accepted by the bidder, other than those listed in unpriced copy of this format.
- Cost of withdrawal is to be given separately for each deviation. In no event bidder should club cost of withdrawal of more than one deviation else cost of withdrawal of such deviations which have been clubbed together shall be considered as NIL.
- In case nature of cost of withdrawal (positive/negative) is not specified it shall be assumed as positive.
- In case of discrepancy in the nature of impact (positive/negative), positive will be considered for evaluation and negative for ordering.

Make Declaration by Bidder

(To be furnished by the bidder along with the bid)

Project:5x800MW Yadadri TPS Stage II

Package: Ventilation System - Axial Fans

Tender Enquiry Number:

Bidder:

Bidder to provide following details that will be part of the contract:

SI No	Name of Item	Approved Makes	Make offered by the bidder (Bidder to tick either of the following options)
1	Axial Fans (Roof extractor, Supply and Exhaust fans)	1. FLAKT, GREATER NOIDA 2. KHAITAN, KOLKATA 3. PATEL AIR, AHMEDABAD 4. KRUGER, SINGAPORE 5. MARATHON, KOLKATA 6. CB DOCTOR 7. ALMONRAD CHENNAI 8. TCF NADI, CHENNAI 9. AVPL, DELHI 10. SK SYSTEMS, DELHI	1.0 As per customer approved list OR 2.0 Any other make - _____(Specify name of the make)

Bidder to note that BHEL shall seek approval of make for Axial fans offered by the bidder (as per above table) from customer. In case, the make offered by the bidder is **not accepted by customer**, bidder has to confirm either of the following (**Bidder to tick either of the following options**):

a) **The deviation wrt make of the axial fans is firm, the offer may be rejected.**

OR

b) **Bidder shall offer makes of Axial fans as per customer approved make list and the offer submitted by the bidder may be considered for evaluation without any commercial & delivery implication to BHEL.**

Date:

(Bidder's Representative)

Sign & Stamp



5X800 MW YADADRI TPS
VENTILATION SYSTEM -Stage II(PART III)

SPECIFICATION No: PE-TS-417-554-A003

SECTION : II

SUB-SECTION : 6

REV 00

DATE: July 23

SHEET

SECTION-II
SUB-SECTION-6
GPC ANNEXURE-
GUARANTEE POWER CONSUMPTION

**5 X 800 MW YADADRI TPS
VENTILATION SYSTEM STAGE-2 PART III
GPC ANNEXURE-GUARANTEED POWER CONSUMPTION FIGURES**

S.NO. (1)	DESCRIPTION (2)	QUANTITY (WORKING) (3)	QUANTITY (STAND-BY) (4)	Total Guaranteed Power Consumption for Each Equipment at motor input terminal and control panel (5)	TOTAL POWER CONSUMPTION AS GUARANTEED (KW) (6) = (3)*(5)
1	RE Units for Power house (Stage II)	41	0		
				TOTAL (KW)	

Note:

- 1 Base figure of aux power consumption as per above criterion for Ventilation System (for working drives only) shall be **205 kW**.
- 2 Bidder's guaranteed power consumption at motor input terminals (not shaft power) as furnished in guaranteed schedule shall be demonstrated by the successful bidder during performance testing at works/site.
- 3 The prices quoted by the bidders shall be loaded @ Rs. 2,00,000/- for each one KW increase in consumption from the base figure indicated at Note no 1 above during bid evaluation stage.
- 4 During actual performance testing at the manufacturing works / site, in case power consumption is noted higher than bidder's quoted guarantee power consumption, then penalty @ Rs. 2,00,000/- per KW shall levied on the bidder for the increase in power consumption with respect to "higher of the base figure indicated at note no 1 above and bidders quoted guarantee power consumption".
- 5 The power consumption indicated above shall be proportionately considered for per unit basis auxiliary power consumption.

Propeller Fan

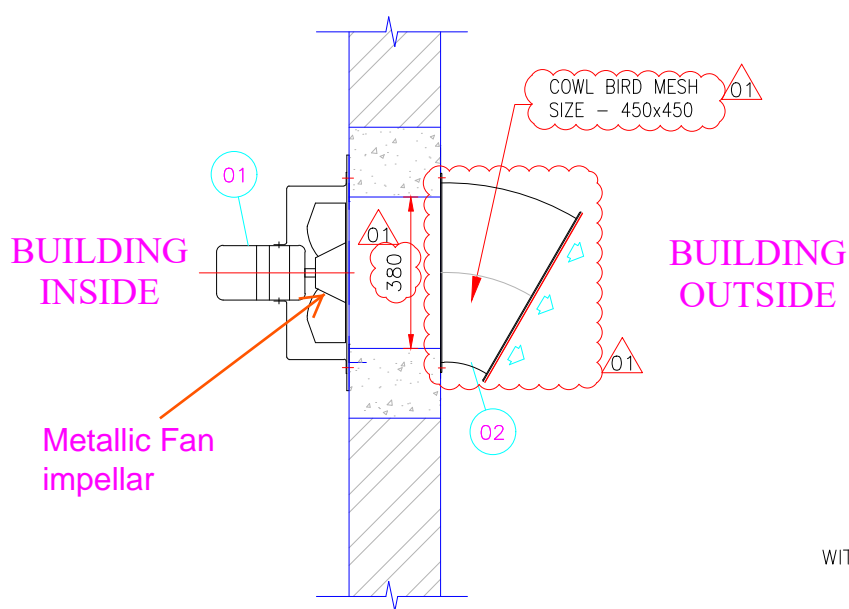

FAN ASSY. DETAIL

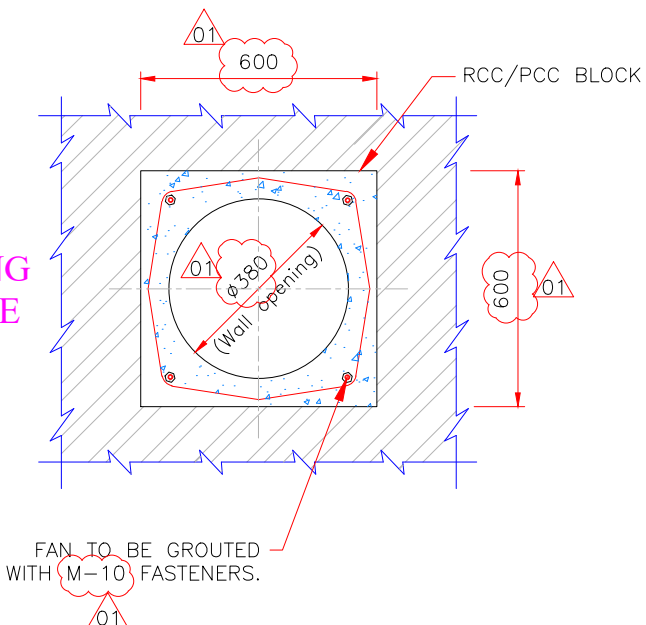

FAN GROUTING DETAIL

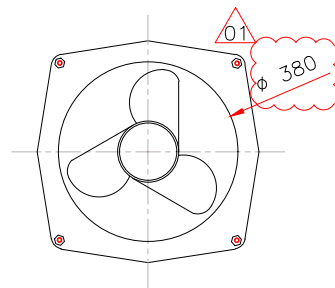

FRONT VIEW

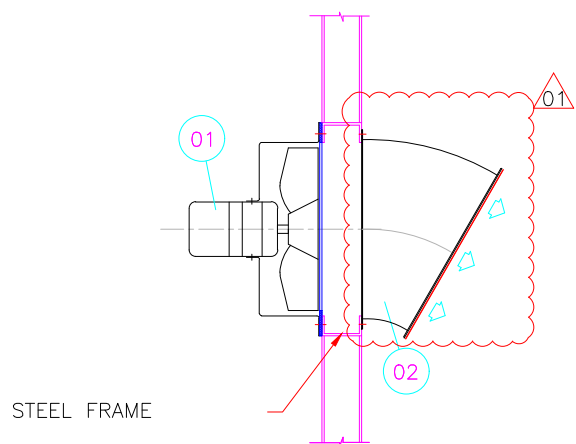

STEEL FRAME

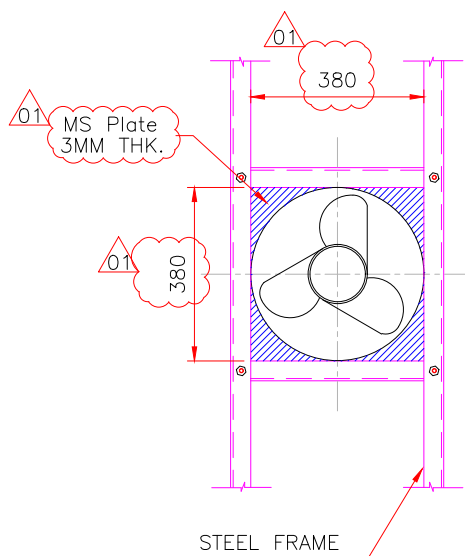

STEEL FRAME

FAN FIXING DETAIL WITH STEEL STRUCTURE

Capacity (CMH)	Fan dia	Phase	Fan Speed (RPM)	Qty. (Nos.)	Static Pressure (mmWG)	Motor Power (Watts)	Fan Dynamic Load (Kg.)
1200	01 380	Single	950	*	5	100 (Approx)	5.5

REFERENCE DOCUMENTS / DRAWINGS	
DOCUMENT / DRAWING NO	DOCUMENT / DRAWING TITLE
PE-V0-417-554-A020	VENTILATION FAN SCHEDULE
LI No:CE/PC/SE-3/EME-11/YTPSP/PEM/CAT PLAND NO.26/21	INSPECTION & TESTING

NOTES:

1. ALL DIMENSIONS ARE IN MM.
2. ITEM LISTED FOR ONE FAN ONLY.

* FAN QUANTITY AS PER APPROVED LAYOUT/ FAN SCHEDULE.

3.Support of fans shall be in bidder's scope

REV.	DATE	DESCRIPTION	DRN BY	CHKD BY	APPD BY
02.		Cowl Bird mesh - 450x450	1 no.	GI/Alu.	
01.		Propeller fan 380#	1 no.	MS	KHAITAN

REV.	DATE	DESCRIPTION	DRN BY	CHKD BY	APPD BY
03	23-09-2021	ISSUED FOR APPROVAL	HS	A. GAUR	S.VERMA
02	25-08-2021	ISSUED FOR APPROVAL	HS	A. GAUR	S.VERMA
01	21-07-2021	ISSUED FOR APPROVAL	HS	A. GAUR	S.VERMA
00	29-01-2021	ISSUED FOR APPROVAL	MUKUL	A. GAUR	S.VERMA

CUSTOMER: TELANGANA STATE POWER GENERATION CORPORATION LTD
 TELANGANA, INDIA
 5x800 MW YADADRI TPS, NALGONDA

CONSULTANT: TATA CONSULTING ENGINEERS LIMITED
 BANGALORE INDIA

BHARAT HEAVY ELECTRICALS LTD
 POWER SECTOR
 PROJECT ENGINEERING MANAGEMENT
 NOIDA

TITLE					
DRN	DESIGN	CHK	APPD	DATE	SCALE
MUKUL	L.PAL	A.GAUR	S.VERMA	29-01-2021	NTS

DRAWING NO. PE-V0-417-554-A020
 SHEET 1 OF 1 REV. 03

APPROVED GA OF FANS (TYPICAL)

DATA SHEET & GA FOR ROOF EXTRACTOR, AXIAL EXHAUST AND SUPPLY AIR FANS WITH FIXING ARRANGEMENT FOR VENTILATION SYSTEM

Customer	Telangana State Power Generation & Corporation	Job Ref. No.	M21/DEL-069.BHEL		
Project	5 x 800 MW YADADRI	Date	15.02.2021		
Doc. No.	PE-V0-417-554-A010	Sheet	1		
Sr. No.	Description	Unit	Particulars		
1	Item		Roof Extractor (Axial flow fan)		
2	Manufacturer				
3	Model No.		AdTV-800/8B	AdTV-1000/8B	AdTV-1200/8B
4	Impeller Speed	RPM	960	960	960
5	Capacity	CMH	20000	40000	50000
6	Location & Usage		As per Approved Fan Schedule - PE-V0-417-554-A008		
7	Static pressure at 20 °C	mmWG	15	15	15
8	Velocity pressure at 20 °C	mmWG	5	9	7
9	Total pressure	mmWG	20	24	22
10	Impeller Diameter	mm	800	1000	1200
11	No. of Blade	Nos.	8	8	8
12	Type of Blade		Fixed Pitch Cast Aluminium Blade		
13	Blade Angle	Degree	27.5	25	17.5
14	Shaft Power at 20 °C	BkW	1.57	4.16	4.34
15	Fan Efficiency	%	70	70	70
16	Fan Critical Speed	RPM	1200	1200	1200
17	Bearing Type & No.		Ball Bearing (6206 ZZ & 6205 ZZ)	Ball Bearing (6208 ZZ & 6305 ZZ)	
18	Weight of Fan				
	a) Static Load	Kg	105	185	225
	b) Dynamic Load		150	225	290
19	Performance curves enclosed (yes/No)		yes		
20	Motor Data				
	a) Rating at 50 °C ambient temperature	kW/Pole	2.2/6	5.5/6	5.5/6
	b) Speed	RPM	960	960	960
	c) Type of Mounting		Foot mounting shaft upward (V6)		
	e) Direction of Rotation		Clockwise / Anti - Clockwise		
21	Material				
	a) Impeller		Cast Aluminium		
	b) Casing		MS Sheet as per IS: 1079/IS: 2062 / IS: 513, 5 mm thk.		
	c) Shaft		Motor Shaft (EN-8)		
22	Hood Thickness		3.15 mm MS		
23	Painting		Spray Galvanization (min. 60 micron DFT)		
24	Galvanized Bird screen of 15 mm sq. with Cowl		Provided		
25	Vibration level		As per ISO: 14694		
26	Accessories		Rain protection Cowl/exhaust hood, transformation piece, steel supports, bird screen		
27	Inspection & Testing		As per approved QAP		

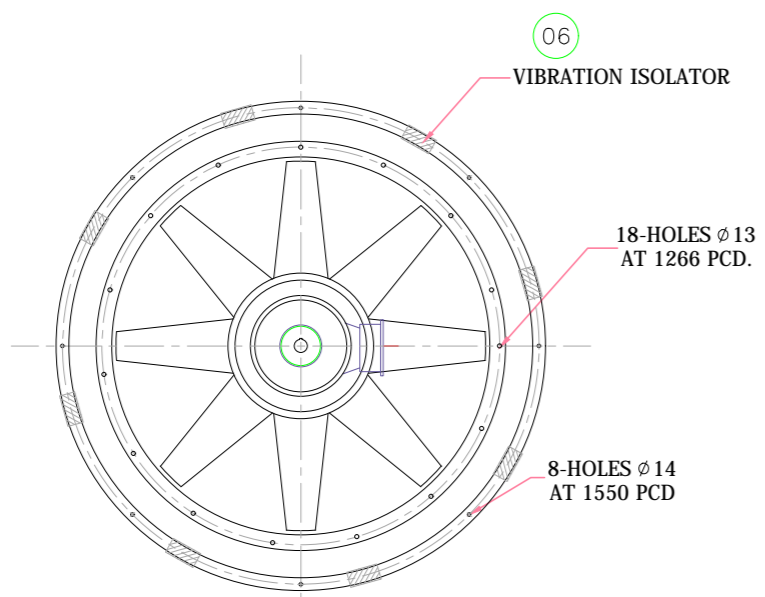

FAN TOP VIEW

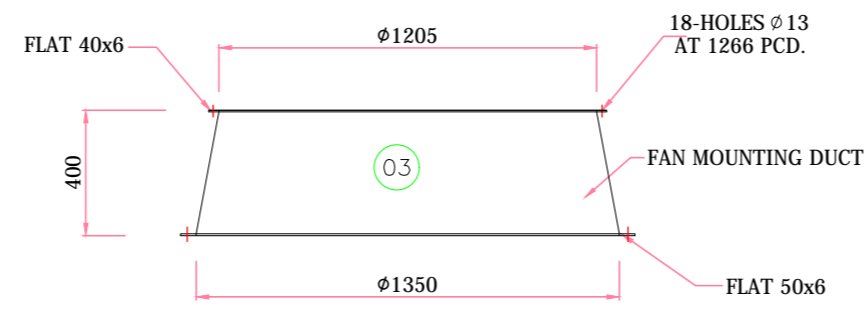

TRANSITION DUCT/HOOD DETAIL FOR ROOF EXTRACTOR FAN

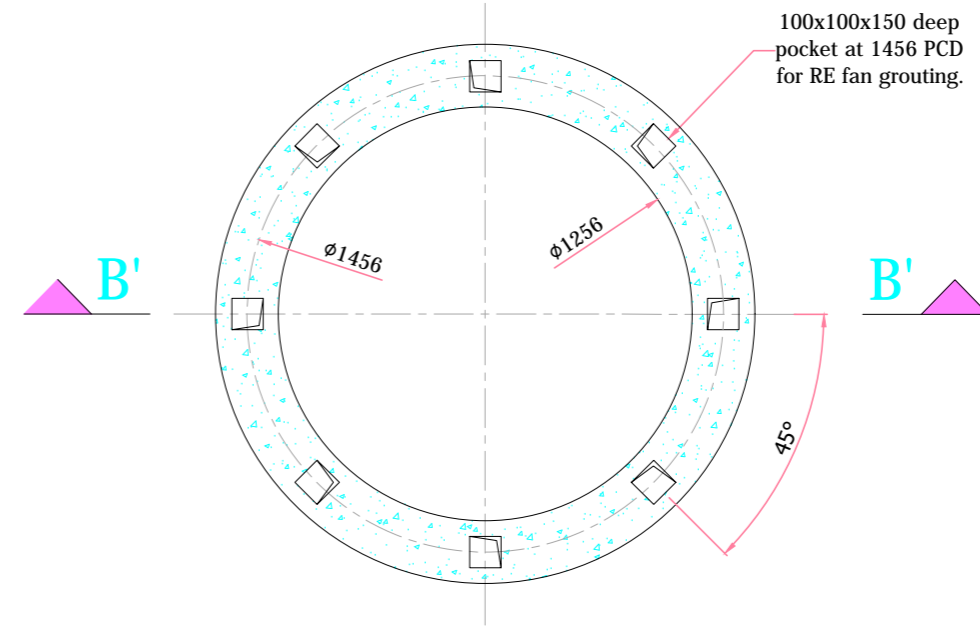

ROOF OPENING DETAIL FOR AdTV-1200/8B

REFERENCE DOCUMENTS / DRAWINGS	
DOCUMENT / DRAWING NO	DOCUMENT / DRAWING TITLE

- NOTES:-
- ALL EQUIPMENTS SHALL BE DESIGNED FOR CONTINUOUS DUTY.
 - ALL DIMENSIONS ARE IN MM, AND ELEVATIONS ARE IN MTRS, UNLESS OTHERWISE STATED.
 - FAN VIBRATION LEVEL SHALL BE AS PER ISO - 14694.
 - 15 MM THK. XLP GASKET WILL BE PROVIDED BETWEEN FAN & TRANSITION HOOD TO AVOID ANY VIBRATION TRANSFER TO ROOF.
 - ITEM LISTED IN THE PART LIST FOR ONE FAN ONLY.
 - REFER APPROVED FAN SCHEDULE FOR FINAL R E FAN QTY.

AIR CAPACITY	: 50,000 CMH
FAN STATIC PRESSURE	: 15 (mmwc)
FAN STATIC LOAD	: 225 KG
DYNAMIC LOAD	: 290 KG

PARTNO.	DESCRIPTION	SIZE	QTY.
06.	VIBRATION ISOLATOR	100x50x12	8 nos.
05.	WIRE MESH (15 MM SQ.)	1200	2 nos.
04.	ROOF EXHAUSTER COWL	1800/ 1485	1 no
03.	FAN MOUNTING DUCT	1350/ 1200	1 no
02.	MOTOR 5.5KW/6POLE	-	1 no
01.	ROOF EXTRACTOR FAN	AdTV-1200/8B	1 no

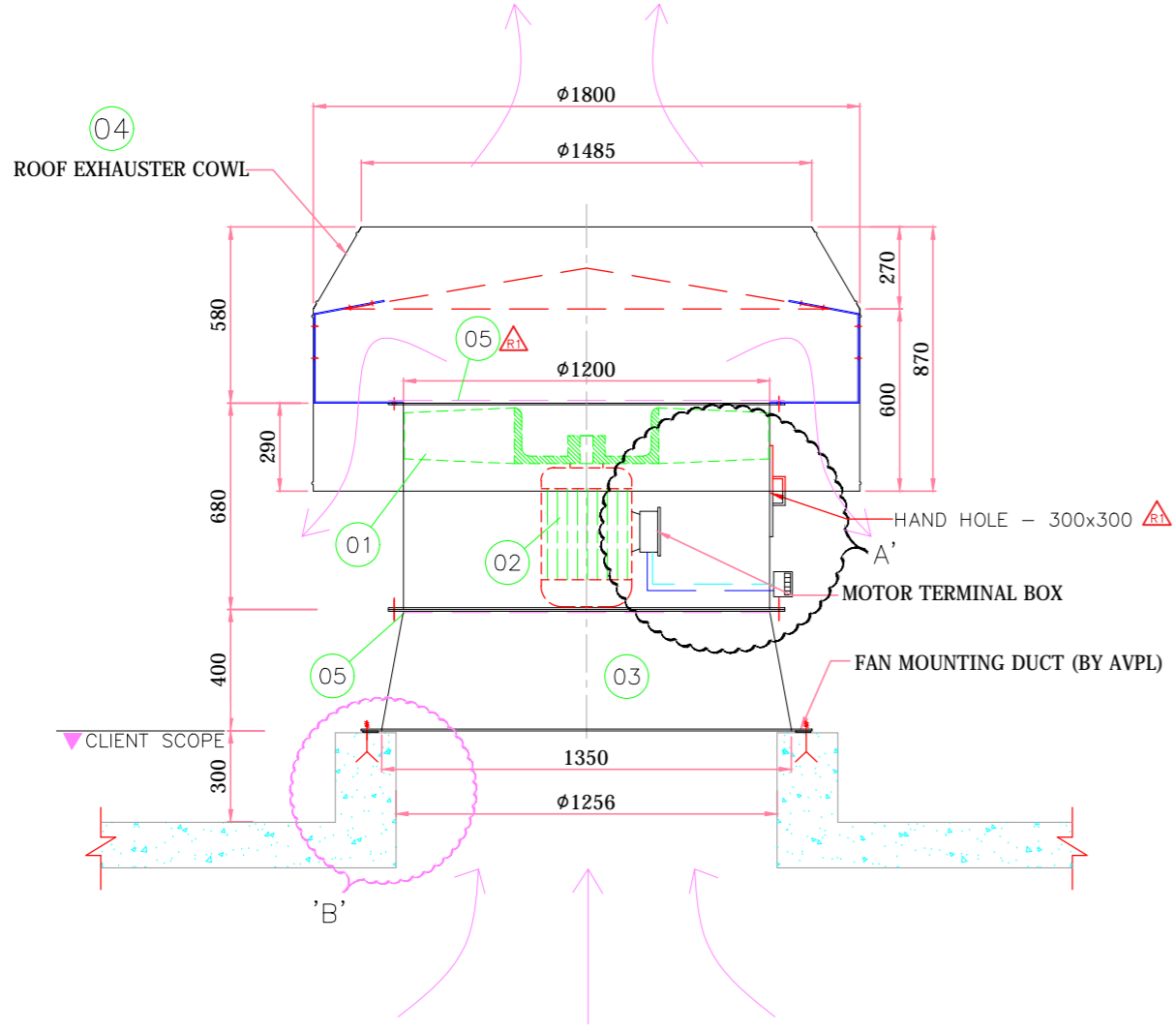

ELEVATION VIEW

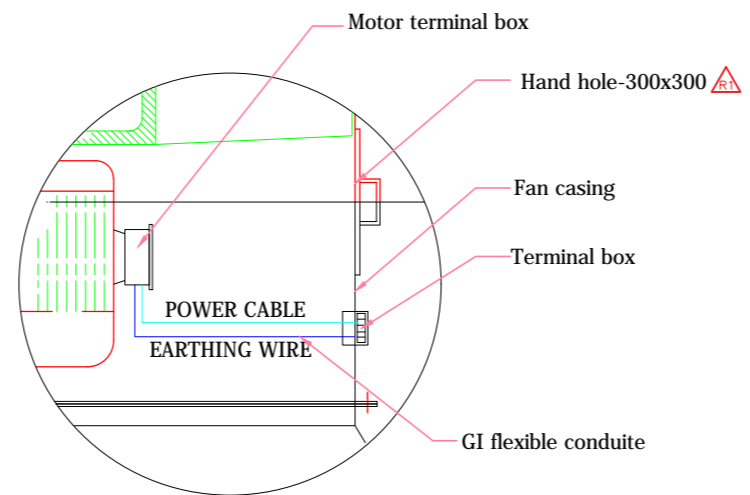

DETAIL 'A'

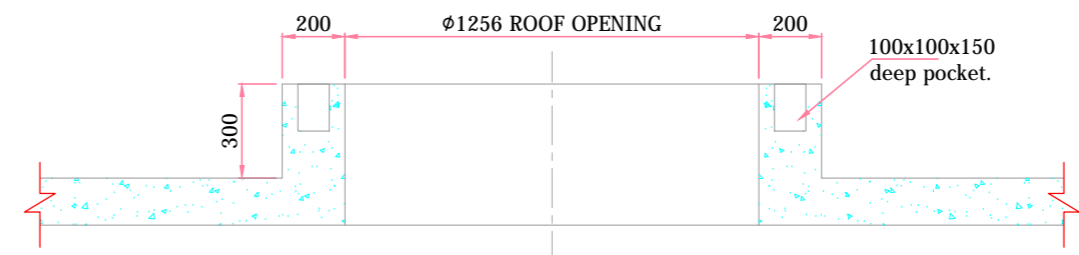

SECTION - 'B' B'

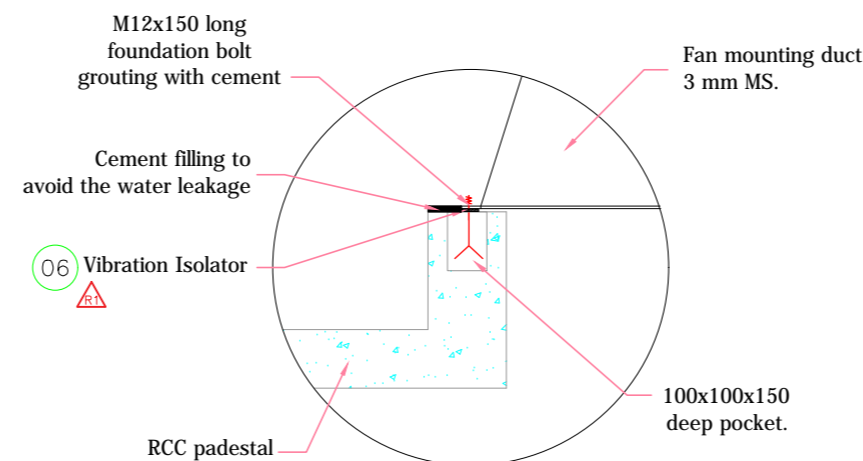

DETAIL 'B'

REV. NO	DATE	DONE BY	CHECK BY	DESCRIPTION
01	10.06.2021	HIMANSHU	A.G.	DRAWING ISSUED FOR REVIEW/ APPROVAL
02	08.03.2021	HIMANSHU	A.G.	DRAWING ISSUED FOR REVIEW/ APPROVAL

CUSTOMER: TELANGANA STATE POWER GENERATION CORPORATION LTD
 TELANGANA, INDIA
 58900 MW YADADRI TPS, NALGONDA

CONSULTANT: TATA CONSULTING ENGINEERS LIMITED
 BANGALORE INDIA

CLIENT: BHARAT HEAVY ELECTRICALS LTD
 POWER SECTOR
 PROJECT ENGINEERING MANAGEMENT

JOB NO.	417
STATUS	CONTRACT
DISTRIBUTION	

REV.	DATE	ALTD	CHD	APPI	TITLE
01.	13.07.21	HK	AG	SC	TECHNICAL DATA SHEET & GA DRAWING FOR ROOF EXHAUSTER ALONG WITH FIXING DETAILS

Client comments Incorporated

DRN	DESIGN	CHD	APPD	DATE	SCALE	DRAWING NO.
H.K	A.G	SCY	SCY	08.03.2021	1:100	PE-10-417-554-4010

SHEET 4 OF 14 REV. 02