



**BHARAT HEAVY ELECTRICALS LIMITED**  
 [A Government of India Undertaking]  
 Ramachandrapuram, Hyderabad, 502032, A.P. India  
 Phone 040-23184526, 23182322 FAX:040-23021910, 1954

**भारत हेवी इलेक्ट्रिकल्स लिमिटेड**  
 (भारत सरकार का उपक्रम)  
 रामचन्द्रपुरम, हैदराबाद, 502032 आंध्र प्रदेश, भारत

RFQ NO :

**PURCHASE DEPARTMENT**  
**ENQUIRY**  
**क्रय विभाग**

SHEET:1  
OF :1

जांच (ई मेल : tenderbox@bhelhyd.co.in)

|                       |  |  |                            |
|-----------------------|--|--|----------------------------|
| HY17001 C<br>REV.NO.0 | Phone 091-40-23184526<br>091-40-23182322 | FAX : 091-40-23021910<br>091-40-23021954 | <b>PURCHASE DEPARTMENT</b> |
|-----------------------|--|--|----------------------------|

|        |                               |                      |                |                                |
|--------|-------------------------------|----------------------|----------------|--------------------------------|
| GSTIN: | Enq/Collective No :G9AWS00011 | Enq.Dt. : 09.06.2023 | No.Of Items :1 | DUE Dt. OF QUOTN. : 19.06.2023 |
|--------|-------------------------------|----------------------|----------------|--------------------------------|

**Office Copy**

Please submit your lowest quotation in sealed cover superscribed with Enquiry No./Collective No.(RFQ No ..... ) and due date subject to our terms and conditions attached ,for the materials mentioned below.Your offer has to reach us onor before due date by 11.00 Hours (IST) and will be opened at 14.00 Hours.(IST).If our Enquiry No./Collective No.(RFQ No ..... ) and tender due date are not super scribed on the tender cover , your offer shall be summarily rejected. Incomplete offers and late offers will not be considered.

| SL NO | Purchase Req.no | item no | Material Code, HSN No. | Drg no - Ver , Rev & Spec - Ver , Rev,Spec-Var | Description            | Unit | Qty   | Delivery Date | Schedule Qty |
|-------|-----------------|---------|------------------------|--|------------------------|------|-------|---------------|--------------|
| 1     | 1700035036      | 10      | 16102001931-00         | 16102001931-00,00,,                            | JOURNAL SKIRT ASSEMBLY | EA   | 9.000 | 05.07.2023    | 9.000        |

Special Remarks

**CheckList of Quality Interventions:**

**BHEL reserves the right to enforce any or all of the following checks during execution of the order.**  
**There is no additional cost to the vendor on account of these checks.**

|  |   |  |
|--|---|--|
|  | TEST CERTIFICATE REQD:<br>GUARANTEE REQ :<br>SAMPLE REQD :<br>BID TYPE : TWO PART | For and on-behalf of<br>Bharat Heavy Electricals Limited.<br><br><b>SRI NAVEEN.B</b><br>ENGINEER |
|--|---|--|



**BHARAT HEAVY ELECTRICALS LIMITED  
RAMACHANDRAPURAM: HYDERABAD 32  
SWITCHGEAR-SUBCONTRACT DEPARTMENT**

**Notice Inviting Tender(NIT)**

Tender Enquiry No: G9AWS00011

Dtd. 09.06.2023

**E-Tenders are invited on Two Part Bid basis for Fabrication & Machining of Journal Skirt Assy as per Scope of Work & drawings with BHEL Free Issue Material.**

**General:**

1. The tender will be under two-part bid system. The first part will be Techno-Commercial Bid and the second part will be Price Bid. Price bids of only those vendors shall be opened who qualify in Techno-Commercial bid.
2. **Mode of Submission of offer:** Being e-tender, offers shall be submitted online only through e-tender portal: <https://eprocurebhel.co.in/nicgep/app>

**Important dates are given below:**

| EVENT                                   | SCHEDULE                                 |
|---|--|
| Last date & time for receipt of tender: | Date: 19.06.2023 & Time: 11.00Hrs (IST)  |
| Tender opening date & time:             | Date: 21.06.2023 & Time: 14.00 hrs (IST) |

**3. E-procurement Service Provider details:**

In case of any difficulty faced while registering on BHEL's e-Procurement portal developed by NIC, queries may be addressed to email ID and Contact No provided below. These details are also available on 'Contact Us' page of the portal

| SNo. | Email Id             | Contact No.                              |
|------|----------------------|--|
| 1    | support-eproc@nic.in | 0120-4001002, 0120-4001005, 0120-6277787 |

The process of utilizing e-procurement necessitates usage of DSC (Digital Signature Certificate) (Class 3- SHA2- 2048 BIT SIGNING & ENCRYPTION) and vendors are requested to procure the same immediately, if not presently available with them. Please note that only with DSC, vendor will be able to login the e-procurement secured site and participate in the tendering process.

4. Offers shall be submitted on e-procurement portal only. Hard copy of offer is not required to be submitted to BHEL HPEP. **Any offer received in hard copy will not be accepted and will straightway be rejected by BHEL HPEP.**



**BHARAT HEAVY ELECTRICALS LIMITED  
RAMACHANDRAPURAM: HYDERABAD 32  
SWITCHGEAR-SUBCONTRACT DEPARTMENT**

5. Offer shall be submitted as per the instructions of tender document and as detailed in this NIT. Price shall not be mentioned anywhere in Techno-Commercial offer. Price shall be furnished in the relevant price schedule only. In case of any clarification, bidder may contact us.

6. **Tender Fee & EMD:** NIL

7. **Item Description and Scope of Supply:**

| SNo. | Item Description   | UoM  | Qty. | Terms of Delivery |
|------|--------------------|------|------|-------------------|
| 1    | JOURNAL SKIRT ASSY | EACH | 09   | F.O.R BHEL-HYD    |

8. **Terms and Conditions**

All Technical and commercial terms and conditions will be as per Techno-Commercial Bid Annexure-A.

Other terms will be as per ITB Rev12.

9. **Special Conditions of Enquiry**

- Vendor Must meet all the attached PQC of the enquiry.
- Participating firm's factory location where the job shall be processed must be within a radius of 50 kms from BHEL, HPEP Hyderabad.
- Currency for evaluation of this tender enquiry is INR.

10. **Attachment to Tender Enquiry:**

| SNo. | Description  | Annexure/Enclosure             |
|------|--|--------------------------------|
| 1.   | Techno-Commercial Terms and Conditions and Scope of Job. | Annexure-A to be submitted     |
| 2.   | Instructions to Bidders                                  | ITB-12 to be submitted         |
| 3.   | Price Bid  | Annexure-B/BOQ to be submitted |
| 4.   | Pre-Qualification Criteria(PQC)                          | PQC to be submitted            |
| 5.   | Drawings & Process sheets.                               |                                |

11. **Contact person details:**

Sri Naveen. B

Engineer / Switchgear-Subcontract

Phone: 040-2318-3088

Mob: 9866528065

E-mail: srinaveen@bhel.in

**PRE-QUALIFICATION CRITERIA FOR FABRICATION AND MACHINING OF JOURNAL SKIRT ASSY HP 1203**

**The bidder has to compulsorily meet the qualifying criteria indicated in section-1 to get qualified. Otherwise the technical offer will not be considered.**

|                  |   |                         |
|------------------|---|-------------------------|
| 1                | Name, address, e-mail id, contact no.etc. of vendor.  |                         |
| <b>Section-1</b> |   |                         |
| <b>SI No</b>     | <b>Requirement</b>  | <b>Vendors Response</b> |
| 1.1              | Only those vendors shall quote who mandatorily meets the clause nos: 1.2 to 1.5   |                         |
| 1.2              | Vendor should have in house facility for rolling above 25thk Carbon steel to dia 500 or more.<br>Vendor should have in house facility for welding of carbon steel.<br>Vendor should perform Stress relieving operation after fabrication<br>Vendor should have the facilities for gas cutting of more than 25mm thick CS plates.<br>Vendor should perform turning operation of dia 450 to 700 mm range. |                         |
| 1.3              | Vendor should have performed and supplied fabricated components with minimum 25 thick CS plates atleast 1 no in last 3 years. Higher capacity than this is also acceptable.PO copy, inspection reports of executed projects shall be submitted to BHEL for review.  |                         |
| 1.4              | Vendor shall not outsource Fabrication & welding operations to other parties.   |                         |
| 1.5              | BHEL reserves the right to accept or reject the offer based on the assesment of their technical capability.<br>BHEL reserves the right to verify the information provided by the vendor by taking feed back or by visit to vendor works. In case the information provided by the vendor is found to be false / incorrect, the offer shall be rejected.  |                         |
| <b>Section-2</b> |   |                         |
| <b>SI No</b>     | <b>Requirement</b>  | <b>Vendors Response</b> |
| 2.1              | Vendor should provide list of machinery available at his works  |                         |
| 2.2              | Vendor should provide list of outsourcing operations if any   |                         |

**ANNEXURE-A**

**TECHNO-COMMERCIAL BID FOR FABRICATION & MACHINING OF JOURNAL SKIRT ASSY.**

**ENQUIRY REF: G9AWS00011/DT:09.06.2023**

**Note: Vendors are requested to fill the format in compliance with the tender specific terms and submit as Techno-Commercial bid. Techno-Commercial Bids are evaluated in line with the each criteria terms and only those price bids are opened, who meets all the Techno-Commercial bid requirements.**

| <b>Sl.</b> | <b>Criteria</b>                              | <b>Techno-Commercial Term</b>  | <b>Sub-Contractor Acceptance</b> |
|------------|--|--|----------------------------------|
| 1          | Scope of work of the job                     | The job to done as per BHEL Drawing and Process Sheet. See the annexure-1 for detailed scope.  |                                  |
| 2          | Raw material scope                           | The required Raw Material will be supplied by BHEL as free issue to the vendor . Normally the optimum sizes of the Raw Material will be supplied as per drawing and process sheet.<br>On non- availability of the specified size raw material, BHEL may issue the higher size material. However, on account of higher size raw material, no additional amount for machining/fabrication will be paid to vendor. Further, increase in delivery period shall not be allowed due to higher size raw material. |                                  |
| 3          | Evaluation                                   | L1 bidder shall be finalised based on item wise evaluation   |                                  |
| 4          | Delivery period                              | Within 45 days from the date of free issue material from BHEL.   |                                  |
| 5          | Scrap  | Scrap recovery will be done as per BHEL Hyd Norms.   |                                  |
| 6          | Tools/Cutters /Gauges /Measuring Instruments | All Tools/Cutters/guages / Measuring Instruments are in Vendor's scope. All guages and measuring instruments shall have valid calibration certificates.  |                                  |
| 7          | Validity                                     | The quotation shall be valid at least for a period of 90 days from the date of technical bid opening date.   |                                  |
| 8          | Inspection                                   | After completion of the job, the same shall be offered for inspection by BHEL at VENDOR works along with dimensional reports.  |                                  |
| 9          | Transportation                               | Free issue material shall be supplied to vendor's works at BHEL's cost and dispatching the finished Item will be in vendor's scope, that means the charges of delivering the job to BHEL's store to be borne by vendor.  |                                  |
| 10         | Delivery Destination                         | Delivery condition to F. O. R. destination to BHEL,R.C.PURAM-HYDERABAD-32  |                                  |
| 11         | Preservation and Packing.                    | Finished materials are to be preserved with oil/preserving agents for delivery to BHEL. The cost of preservation and packing shall be included in each price quoted.   |                                  |
| 12         | Penalty                                      | In the event of delay in supply of goods, penalty of 0.5% per week or part there of shall be levied on the undelivered portion subject to a maximum of 10% of the total order value.   |                                  |
| 13         | ITB Conditions                               | Acceptance for all applicable Terms & Conditions of ITB Rev.12.<br><b>FILLED &amp; SIGNED ITB DOCUMENT IS TO BE SUBMITTED ALONG WITH TECHNO-COMMERCIAL BID (ANNEXURE-A)</b>  |                                  |
| 14         | Firm price clause                            | The quoted price shall be firm till the complete execution of the subcontract order and no escalation of any account will be admissible.   |                                  |
| 15         | Tie of Prices                                | In course of evaluation, if more than one bidder happens to occupy L1 status, effective L1 will be decided by soliciting discounts from the respective L1 bidders.<br>In case of more than one bidder happens to occupy the L1 status even after soliciting discounts, the L1 bidder shall be decided by a toss/draw of lots, in the presence of the respective L1 bidders or their representative.<br>Ranking will be done accordingly. BHEL's decision in such situation shall be final and binding.     |                                  |
| 16         | BANK GUARANTEE                               | BG is required against free issue material as per following condition:<br><b>10% of the material value is required as Bank Guarantee.</b><br>BG shall be valid for atleast 1 year and shall be as per BHEL prescribed format only. BG shall be submitted within 14 days from PO placement date.<br>Note: Bank Guarantee can be submitted in the form of FDR also.  |                                  |

| Sl. | Criteria                                     | Techno-Commercial Term   | Sub-Contractor Acceptance |
|-----|--|--|---------------------------|
| 17  | RISK PURCHASE                                | These items are required for project where delivery is very critical and timely delivery is essence of this contract. In case, any vendor approved for the proposed framework agreement fails to accept/execute the order, BHEL may get the job done through other sources at the risk and cost of those vendors and the extra expenditure involved shall be recovered from these vendors from any amount due to them. Also, BHEL may suspend business dealing with such vendors as per BHEL's guidelines for Suspension of Business Dealings with Suppliers/Contractors.  |                           |
| 18  | Payment                                      | <p>a) Micro &amp; Small Enterprises (MSEs)- 100% Direct EFT payment within 45 Days.</p> <p>b) Medium Enterprises- 100% Direct EFT payment within 60 Days.</p> <p>c) Non MSME Bidders- 100% Direct EFT payment within 90 Days.</p> <p>NOTE:</p> <p>i) Above due date is reckoned from the date of Receipt of material or Invoice date whichever is later. Payment will be made on acceptance of Material.</p> <p>ii) MSEs (covered under MSME Act) need to register and renew periodically and update the same with BHEL.</p> <p>iii) The taxes that are reimbursed are limited to applicable taxes are on the Purchase Order delivery date or the amount actually paid whichever is less.</p> <p>iv) Adherence to the above time schedule of payment is contingent upon Bidder complying with GST provisions and availment of input Tax Credit by BHEL before the date of payment.</p> |                           |
| 19  | TAXES  | <p>-Job worker to provide Tax invoice to BHEL and GST at applicable rates on the services charges will be paid to Job worker against GST compliance and on availment of Input Tax credit by BHEL.</p> <p>-TDS as per the extant statutes shall be deducted.</p> <p>-In case bidder does not provide PAN details, higher rate of tax shall be deducted as per the Act.</p> <p>-Concessional certificates, if any, should be provide well in time for lower tax deduction.</p>   |                           |
| 20  | Defects after receipt of finished components | On receipt of finished items at destination, if any mfg. defects are noticed, the same shall be attended to by the vendor at their own cost without any delay.   |                           |
| 21  | Discretion clause                            | BHEL RESERVES THE RIGHT TO ACCEPT OR REJECT ANY OFFER PARTLY OR FULLY AT ITS DISCRETION WITHOUT ASSIGNING ANY REASON   |                           |
| 22  | Force majeure clause                         | Force majeure clause will be applicable only in case of earthquakes, floods, riots or any act of God beyond control of the contractor. Breakdown of equipment shall not be considered as force majeure   |                           |
| 23  | Arbitration                                  | Arbitration : all disputes arising out of this contract shall be referred to the Unit Head, HPEP, BHEL R.C.Puram, Hyderabad 502032, or his authorized representative for arbitration and his decision shall be final and binding.  |                           |
| 24  | Jurisdiction                                 | Jurisdiction : In case of any suit or other legal proceedings arising under or relating to the contract, the courts at Sangareddy District, Telanagana only shall have the jurisdiction and this will be resorted only after exhausting the arbitration clause as above.   |                           |
| 25  | Other GENERAL terms & Conditions             | Acceptance to all other BHEL general terms and conditions as mention in the enquiry/guidelines document.   |                           |
|     |  |  |                           |

| Sl.   | Criteria  | Techno-Commercial Term  | Sub-Contractor Acceptance |
|-------|---|---|---------------------------|
|       |   | <b>Annexure-I</b>   |                           |
| Sl.no | Job details   | Scope of Supply   | Sub-Contractor Acceptance |
| 01    | 16102001931-00<br>Journal Skirt Assy.<br><br>Qty : 9nos | <p>Fabrication and Machining of the job shall be done strictly as per BHEL drawings and Technological process only.<br/>No deviations are allowed.<br/>Refer drawing no:16102001931-00 and 36102004080-00.</p> <ol style="list-style-type: none"> <li>1. Fabrication/Machining/Stress relieving as per BHEL Drawing and process.</li> <li>2. Grit/Sand Blasting followed by Primer Paint application as per the instruction from BHEL at the time of Blasting Stage.</li> <li>3. Vendor shall follow the Technological process given by BHEL. Vendor is advised to Collect the technological process for all items.</li> <li>4. If the vendor is supplying item for first time, first piece qualification shall be carried out by BHEL-QC. After clearance of first piece only vendor has to take up manufacturing of remaining components.</li> <li>5. CS machined surfaces shall be protected with rust preventive oil/solution.</li> <li>6. <b>Inorganic Zinc Silicate paint to be used. 2 Coats 75 microns min DFT total required. Paint is in vendor scope. Painting to be done as per customer approved painting schedule.</b></li> </ol> |                           |

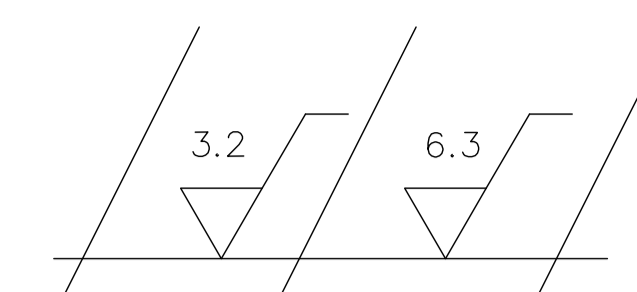
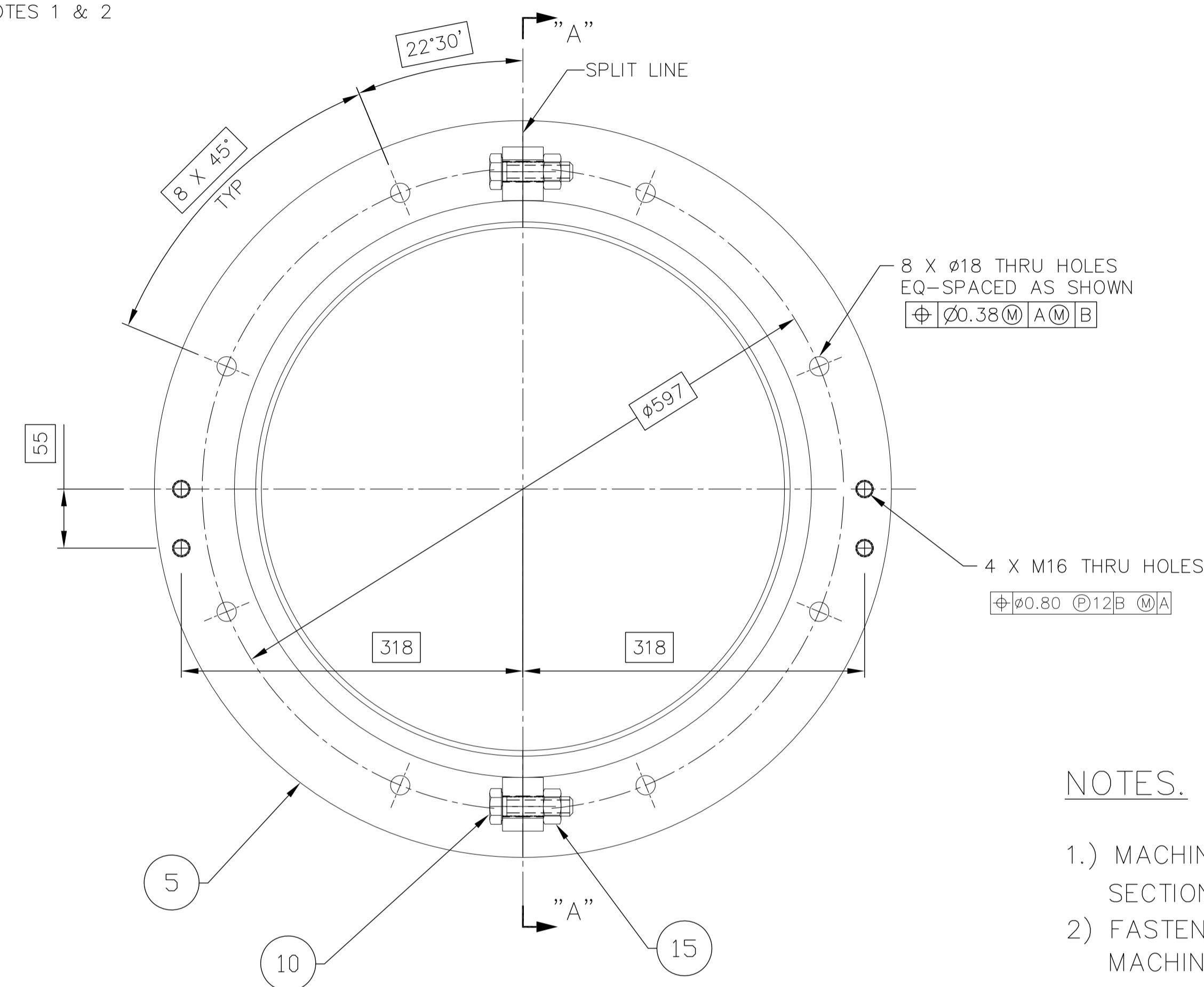
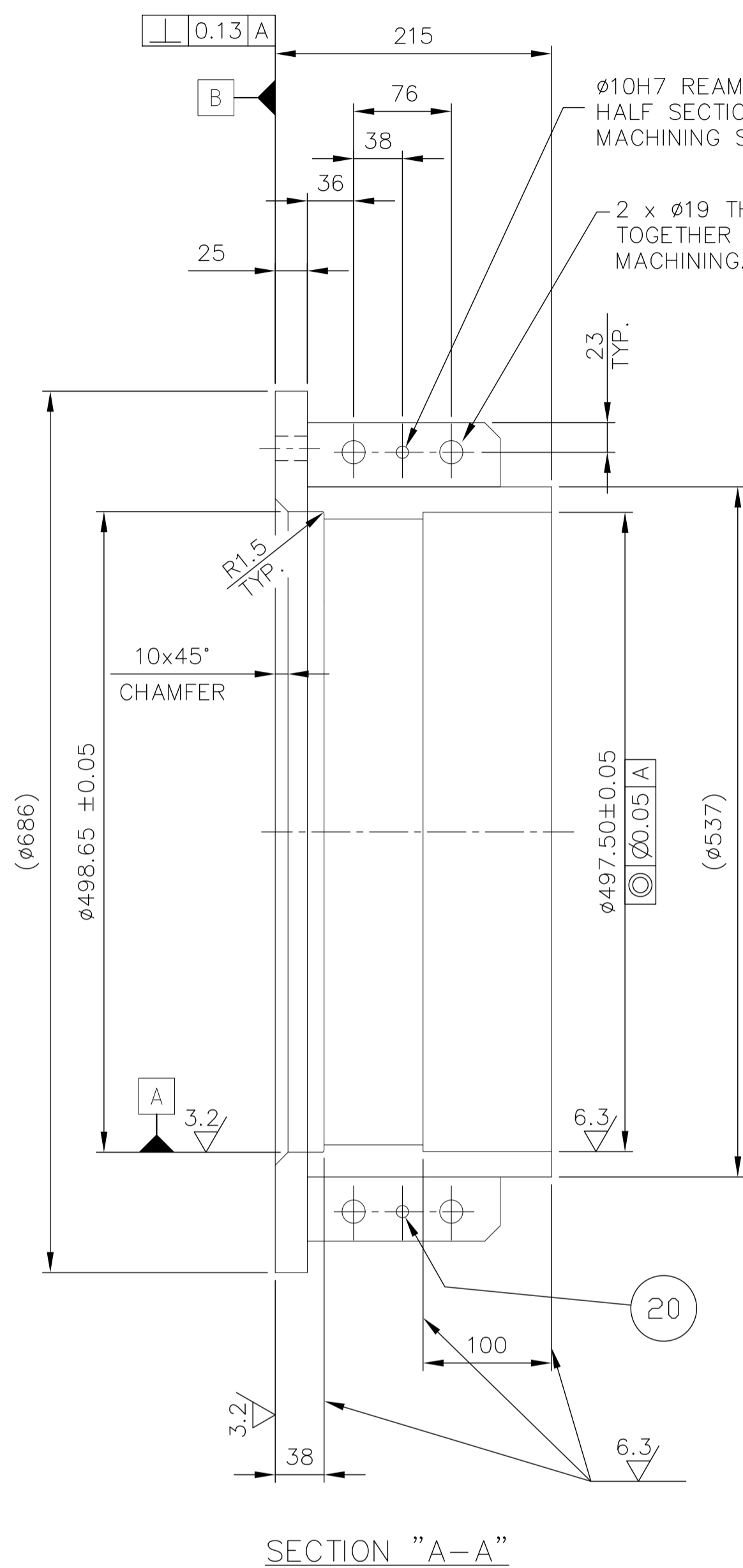

NOTES.

- 1.) MACHINE HALF SECTIONS (2 Nos. ITEM NO. 5) TOGETHER PER SECTION 'A-A' FOR DOWEL PIN AND BOLT LOCATION.
- 2.) FASTEN HALF SECTIONS TOGETHER WITH ITEM NO. 10,15 & 20 THEN FINISH MACHINE TOGETHER.
- 3.) PARTS MUST STAY TOGETHER AS SETS DURING SHIPPING AND STORAGE.
- 4.) UNLESS OTHERWISE NOTED, TORQUE ALL HEX. HD. CAP SCREWS AND APPLY THREAD LOCKING SEALANT PER DRG. B-PLVB-0928 AT FINAL ASSEMBLY.

THIS DWG. DOES NOT CONTAIN ALL INFORMATION NECESSARY FOR MFG. THIS PART. REFER TO RELEVANT PROCUREMENT SPECIFICATIONS & BILL OF MATERIALS FOR COMPLETE MATERIAL IDENTIFICATION & PROCESSING.

| ITEM NO. | DESCRIPTION | DRAWING NO. | VAR. NO. | RAW MATERIAL SIZE OR CASTING DRG. NO. OR FORGING DRG. NO. | MATERIAL CODE   | NET WT.  | GROSS WT. |
|----------|-------------|-------------|----------|---|-----------------|----------|-----------|
|          |             |             |          |   | MATERIAL SPECN. | QUANTITY |           |

NON-CAST PARTS (FABRICATED AND /OR MACHINED)  
 ALL DIMENSIONS ARE IN MILLIMETERS  
 TOLERANCES UNLESS OTHERWISE NOTED  
 XXX ±0.40  
 X & XX ±1.5 FOR DIM. 0-610 MM  
 X & XX ±3.8 FOR DIM. 610-2440 MM  
 X & XX ±6.3 FOR DIM. OVER 2440  
 ANGULAR: ±0°30'  
 DRILLED HOLES: Ø 0-25MM +0.25/-0.00 OVER 25 MM +0.50/-0.00  
 SURFACE TEXTURE: 25 MICRO METERS  
 ROUGHNESS AVERAGE-Ra  
 THIS DRAWING IS IN ACCORDANCE WITH ISD 1101 UNLESS OTHERWISE SPECIFIED, THE THREAD PITCH IS STANDARD COARSE.

|                          |                        |  |           |                   |                 |
|--------------------------|------------------------|--|-----------|-------------------|-----------------|
| TYPE OF PRODUCT          |                        | HP 1203 BOWL MILL                          |           |                   |                 |
| NAME OF CUSTOMER/PROJECT |                        | BHARAT HEAVY ELECTRICALS LIMITED HYDERABAD |           |                   |                 |
| DRN.                     | K.C.MOHAN              | SIGN.                                      |           | DATE              | 23.12.13        |
| CHD.                     | AMAN                   |  |           |                   | 23.12.13        |
| APPD.                    | S.GHATGE               |  |           |                   | 23.12.13        |
| DEPT.                    | 446                    | UNTO. DIMS. GR.                            | B/M/F     | SCALE             | NTS             |
| CODE                     | PULV.                  | WEIGHT (KG)                                | 91.0      | REF. TO ASSY DRG. |                 |
| TITLE                    | JOURNAL SKIRT ASSEMBLY |  | CARD CODE | DRAWING NO.       | 1-61-020-01931  |
|                          |                        |  |           | SHEET NO. 01      | NO OF SHEETS 01 |

BREAK SHARP EDGES AND CORNERS UNLESS OTHERWISE NOTED.

ALL WELDS SHALL BE IN ACCORDANCE WITH THE AMERICAN WELDING SOCIETY, STRUCTURAL WELDING CODE AWS D1.1 OR ASME SECTION IX, UNLESS OTHERWISE NOTED.

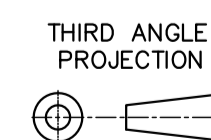

| REV. | DATE | ALTERED    | REV. | DATE | ALTERED    | REV. | DATE | ALTERED    |
|------|------|------------|------|------|------------|------|------|------------|
| ZONE |      | CHD./APPD. | ZONE |      | CHD./APPD. | ZONE |      | CHD./APPD. |
|      |      |            |      |      |            |      |      |            |

THE INFORMATION ON THIS DOCUMENT IS THE PROPERTY OF BHARAT HEAVY ELECTRICALS LIMITED. IT MUST NOT BE USED DIRECTLY OR INDIRECTLY IN ANY WAY DETRIMENTAL TO THE INTEREST OF THE COMPANY.

COMPUTER FILE NAME

INVENTORY NO. SIGN. AND DATE REF. DRG. NO. D-110-01261M-02

DRG. NO. 3-61-020-04080

WPS NO.: WE-001

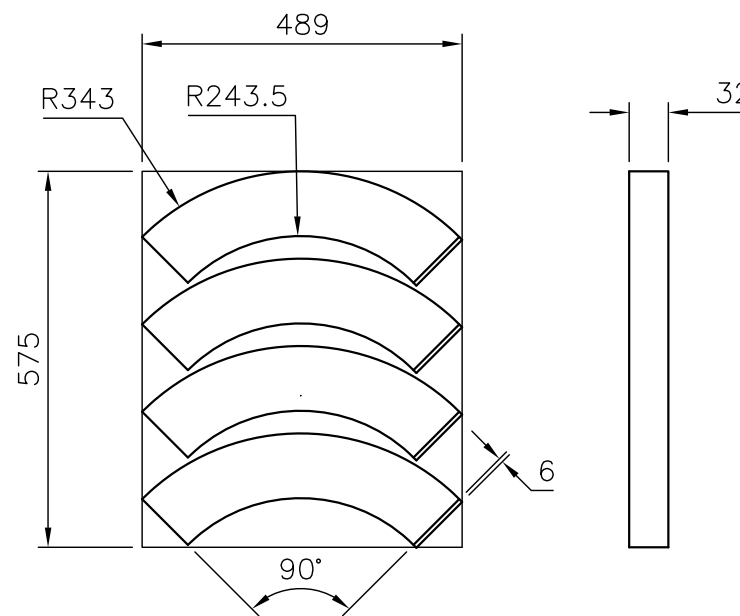
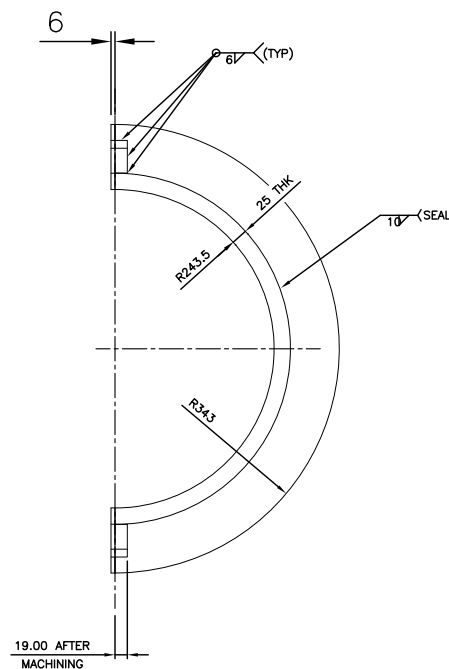
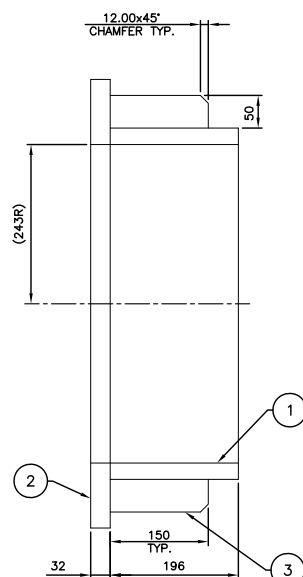

ITEM-02 CUTTING PLAN

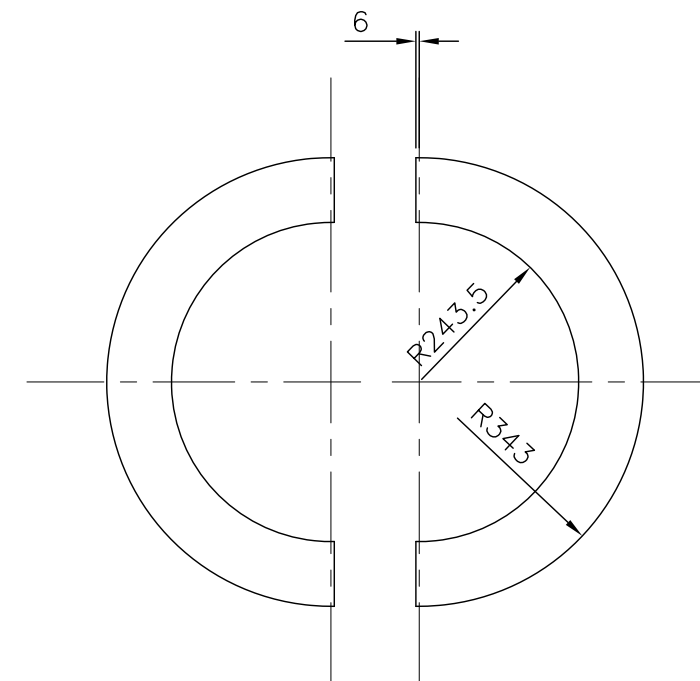

ITEM-02

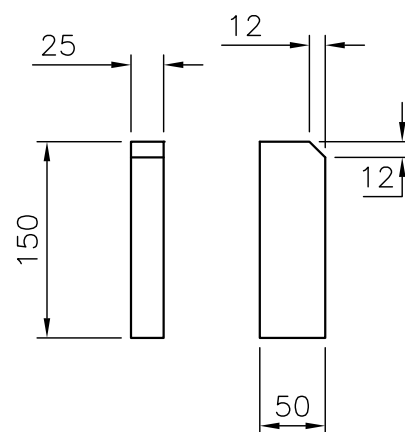

ITEM-03

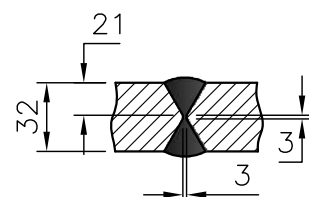

EDGE PREPARATION FOR ITEM-02

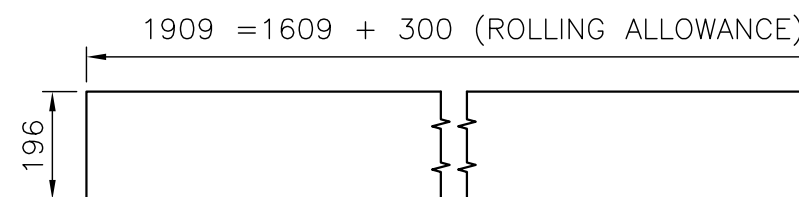

ITEM - 01: DEVELOPED LENGTH

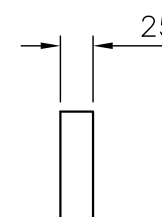

NOTE:

- ITEM-1 TO BE CUT IN TWO HALVES AFTER ROLLING

| ITEM NO. | DESCRIPTION | DRAWING NO. | VAR. NO. | RAW MATERIAL SIZE OR CASTING DRG. NO. OR FORGING DRG. NO. | MATERIAL CODE   | NET WT.  | GROSS WT. |
|----------|-------------|-------------|----------|---|-----------------|----------|-----------|
|          |             |             |          |   | MATERIAL SPECN. | QUANTITY |           |



FOLLOWING CONDITIONS APPLY PT OTHERWISE STATED.

- TO HY0230261 FOR SPECIFIED TOLERANCES.
- CHAMFER M/CD. SHARP EDGES 1.2 TO 1.0 AT 45°.
- INTERNAL M/CD. CORNER RADII 1 TO 0.7
- THE SURFACE ROUGHNESS WHERE-EVER NOT SHOWN SHALL BE TAKEN FROM THE SURFACE ROUGHNESS SHOWN OUT SIDE THE BACK SLASH GIVEN OR THE TOP MOST RIGHT CORNER OF THE DRG.

TYPE OF PRODUCT

NAME OF CUSTOMER/PROJECT

|   |       |             |          |             |
|---|-------|-------------|----------|-------------|
| BHARAT HEAVY ELECTRICALS LIMITED<br>HYDERABAD | DRN.  | ASHOK REDDY | 16.04.14 | NO. OF VAR. |
|   | CHD.  | AMAN        | 16.04.14 |             |
|   | APPD. | S.GHATGE    | 16.04.14 |             |

|                                    |                        |                 |                 |                                  |             |              |
|------------------------------------|------------------------|-----------------|-----------------|----------------------------------|-------------|--------------|
| DEPT. PULV ENGG. CODE 446          | UNTOL. DIMS. GR. 4/M/Y | SCALE 1:10      | WEIGHT (KG) 109 | REF. TO ASSY DRG. 1-61-020-01937 | ITEM NO. 25 | NO. OF ITEMS |
| TITLE JOURNAL SKIRT ASSEMBLY (FAB) |                        |                 |                 | DRAWING NO. 3-61-020-04080       | REV. 00     |              |
| SHEET NO. 01                       |                        | NO OF SHEETS 01 |                 |                                  |             |              |

| REV. | DATE | ALTERED CHD. | APPD. | REV. | DATE | ALTERED CHD. | APPD. | REV. | DATE | ALTERED CHD. | APPD. |
|------|------|--------------|-------|------|------|--------------|-------|------|------|--------------|-------|
|      |      |              |       |      |      |              |       |      |      |              |       |

Material 16102001931-00 Plant P003

| JOURNAL SKIRT ASSEMBLY |            | JOURNAL SKIRT ASSEMBLY |            | EA        |
|------------------------|------------|------------------------|------------|-----------|
| Group                  | 50261807   | Grp.ct                 | 1          |           |
|                        | LSize From | LSize To               | 99,999,999 |           |
|                        | Use        | Status                 | 4          | PlantP003 |

| Sequence  | 0    | Seq. Cat. | Std.seq. |  |
|-----------|------|-----------|----------|--|
| Operation | 0010 | Work Ctr  | HB9863   | Verify the following attestations.<br>1) Material attestation.<br>2) SR chart.<br>3) Dimensional verification and<br>4) Painting schedule.   |
|           |      | Ctrl Key  | QM01     |  |
|           |      | Base Qty  | 1        | EA   |
| Operation | 0020 | Work Ctr  | HB5136   | 1) Hold the two halves of the Journal skirt assly on the machine table such that parting plane facing up words, set, align and clamp firmly.<br>2) Mill the parting planes on both the halves and ensure the dimensions of ID(>&<)>OD, thickness of clamping plate and center axis.  |
|           |      | Ctrl Key  | ZP01     |  |
|           |      | Base Qty  | 1        | EA   |
|           |      | Setup     | 25       | MIN Machine 100 MIN  |
|           |      | Labor     | 100      | MIN  |
| Operation | 0030 | Work Ctr  | HB9421   | Mark the following for drilling:<br>1) 4 holes (2 holes on each side of parting plane, for both the halves) of dia. 19 through at a distance 23mm form the OD and at 38mm & 100mm from the flange face as shown in the drawing at section A-A.<br>2) 2 holes (1 holes on each side of parting plane, for both the halves) of dia. 9.525 through at a distance 23mm form the OD on the flange face as shown in the drawing at section A-A.<br>3) 4 holes (2 holes on each side of parting plane, for both the halves) for M16 through as shown in the drawing at section A-A.   |
|           |      | Ctrl Key  | ZP01     |  |
|           |      | Base Qty  | 1        | EA   |
| Operation | 0040 | Work Ctr  | HB4651   | 1) Hold the two halves of the Journal skirt assly such that parting plane facing up words, set align and clamp firmly on the machine table.<br>2) Drill 4 holes (2 holes on each side of parting plane, on both the halves) of dia. 19 through on parting plane clamping plate as per marking (Refer section A-A of the drawing).<br>3) Dis assemble the two halves and assemble them with item nos. 3&4 and drill 2 holes of dia. 9.7 for 10H7 (for pins, item no.2) through on parting plane clamping plate as per marking (Refer section A-A of the drawing).<br>4) Ream the two pin holes of dia.10H7 and assemble the pins item no. 2.<br>5) 4 holes (2 holes on each side of parting plane, for both the halves) for M16 through as shown in the drawing at section A-A. |
|           |      | Ctrl Key  | ZP01     |  |
|           |      | Base Qty  | 1        | EA   |
|           |      | Setup     | 30       | MIN Machine 60 MIN   |
|           |      | Labor     | 60       | MIN  |
| Operation | 0050 | Work Ctr  | HB9863   | Inspect the above operation.   |
|           |      | Ctrl Key  | QM01     |  |
|           |      | Base Qty  | 1        | EA   |
| Operation | 0060 | Work Ctr  | HB4142   | 1) Hold the assembly (Two halves together) on OD 537 in chuck, set, align and clamp. Refer section A-A.<br>2) Take reference cut on OD 686.<br>3) Turn face and maintain flange thickness 25mm.<br>4) Turn bore dia. 498.65±0.05 to depth 38 with R1.5.<br>5) Chamfer 10X45 degree.<br>6) Reverse the job, hold on flange OD 686 in chuck, set align and clamp.<br>7) Turn face of dia. 537 and maintain total length 215mm.<br>8) Turn bore dia. 497.5±0.05 to length 100.  |

|                |          |        |     |  |         |
|----------------|----------|--------|-----|--|---------|
|                | Ctrl Key | ZP01   |     |  |         |
|                | Base Qty |        | 1   | EA   |         |
|                | Setup    |        | 30  | MIN Machine  | 120 MIN |
|                | Labor    |        | 120 | MIN  |         |
| Operation 0070 | Work Ctr | HB9863 |     | Inspection.<br>Send to IS 3505   |         |
|                | Ctrl Key | QM01   |     |  |         |
|                | Base Qty |        | 1   | EA   |         |
| Operation 0080 | Work Ctr | HB4651 |     | Mark & Drill 8 holes of Dia.18 through on PCD 597 on item no.1 as shown<br>in the drawing. |         |
|                | Ctrl Key | ZP01   |     |  |         |
|                | Base Qty |        | 1   | EA   |         |
|                | Setup    |        | 15  | MIN Machine  | 15 MIN  |
|                | Labor    |        | 15  | MIN  |         |
| Operation 0090 | Work Ctr | HB9863 |     | Final Inspection.  |         |
|                | Ctrl Key | QFNL   |     |  |         |
|                | Base Qty |        | 1   | EA   |         |



| (Attachment to Enquiry No. XXXXXXXXXXXX Due on Date XX.XX.XXXX for submission by 11.00 hrs to open from 14.00 hrs.)   |   |   |
|---|---|---|
| <b>INSTRUCTIONS TO BIDDER (ITB)</b>   |   |   |
| <b>NOTE: Bidder to confirm in affirmative by typing "YES" or "Applicable Data" in the response column. Deviations, if any shall be recorded in deviations/comments column (Separate sheet can be attached if needed). Non deviatable clauses are indicated as "NON DEVIATABLE".</b> |   |   |
| Sl. No.   | DETAILED TERMS & CONDITIONS   | BIDDER RESPONSE (YES/NO) / DEVIATIONS / COMMENT |
| <b>1</b>  | <b>SCOPE OF SUPPLY:</b>   |   |
|   | Signed & Sealed offers are invited for the Scope of Supply of goods or services or both as detailed in the enquiry. Relevant enclosures/supporting documents / catalogue, if any shall be enclosed to the technical offer.  |   |
| <b>2</b>  | <b>DEFINITIONS</b>  |   |
| A   | 'The Buyer' means BHEL-HPEP, Ramachandrapuram, Hyderabad-502 032 of Bharat Heavy Electricals Limited (A Govt. of India Undertaking) incorporated under the companies Act having its registered office at BHEL House, Siri fort, New Delhi-110049, India and shall be deemed to include its successors and assigns. It may also be referred to as BHEL.  |   |
| B   | 'The Bidder' means the persons, firm, company or organization on whom the Purchase order is placed and shall be deemed to include the bidder's successors, representatives, heirs, executors and administrator as the case may be. It may also be referred to as Contractor, supplier or bidder.  |   |
| C   | 'Contract' shall mean and include the Purchase order incorporating various documents viz., Notice Inviting Tender (NIT), Offer, Letter Of Intent/Acceptance (LOI/LOA), Instruction to Bidders (ITB) and Special Conditions of Contract (SCC), specifications, inspection/quality plan, schedule of prices and quantities, drawings, if any, enclosed by Bidder/ provided by the Buyer or his authorized nominee and the samples or patterns if any to be provided under the provision of the contract. In case of any inconsistency or contradiction between any of the documents, the order of precedence shall be Purchase Order, LOI/LOA followed by Minutes Of Meeting (MOM), NIT, SCC, ITB.  |   |
| D   | 'Parties to the contract' shall mean the bidder and the buyer as named in the main body of the Purchase Order.  |   |
| E   | 'Goods/Material' shall include Works and Services which are incidental or consequential to supply.  |   |
| <b>3</b>  | <b>GENERAL INSTRUCTIONS:</b>  |   |
| A   | Mode of submission of offer shall be as indicated in SCC  | <b>Non Deviatable</b>                           |
| B   | The quotation should be neatly typed and free from over writing/ erasures. Any correction or addition must be authenticated. The offer including annexures and brochures should be submitted in English / Hindi. All Pages of Techno Commercial Bids (Main Pages), ITB, SCC should be signed and Stamped. If there is a conflict in case of bilingual submission, the submission in English will be final. Prices shall be quoted both in figures and words. In case of any discrepancy in value, the prices quoted in words shall be considered for evaluation and establishing L1 Status. Any discount / revised offer / bids submitted by a bidder on his own shall be considered, provided it is received on or before the due date and time of offer / bid submission (Part-1). Conditional discounts shall not be considered for evaluation of tenders. | <b>Non Deviatable</b>                           |
| C   | Incomplete offers are liable for rejection.   | <b>Non Deviatable</b>                           |
| D   | Bidders to please note that the Terms & conditions contained in this document and SCC are to be read fully before submission of quotations.   | <b>Non Deviatable</b>                           |
| E   | Bidders are advised to comply with ITB and SCC, should there be any deviations (where deviations are permitted), it shall be entered in the deviation column. BHEL reserves the right to reject such offers or load the bid suitably for evaluation.  | <b>Non Deviatable</b>                           |
| F   | Offers shall be submitted directly, only by the bidder or by their authorized representative / agent and the offer should be in line with the regulatory guidelines (i.e. A valid Agency agreement between principal bidder and agent / representative shall be attached and the agreement shall cover the scope of services rendered by Agent, Agency Commission and any other information called for as per the regulatory guidelines). OEM / Mill details shall be provided if bidder is not a manufacturer. Bid envelopes shall bear the name of Bidder. In case of submission through authorized representative/agent, the name of representative/agent should also be mentioned apart from bidder name.   | <b>Non Deviatable</b>                           |
| G   | Offer received after the specified time and date of submission will be rejected. No further correspondence shall be entertained.  | <b>Non Deviatable</b>                           |
| H   | Unsolicited offers will not be considered.  | <b>Non Deviatable</b>                           |
| <b>4</b>  | <b>OTHER PARTICULARS (Please indicate applicable data)</b>  |   |
| A   | Name of the Bid currency (freely tradable foreign currency for imports and Indian Rupees for indigenous purchase).  |   |
| B   | Name of the Port of loading and Port of Discharge (applicable to imports).  |   |



|           |   |                       |
|-----------|---|-----------------------|
| <b>5</b>  | <b>BID SUBMISSION PROCEDURE FOR CONVENTIONAL TENDER:</b>  |                       |
| <b>A</b>  | <b>For Single Part Bids:</b>  |                       |
|           | The complete bid shall be submitted in a single sealed cover superscribing the Tender number and due date, addressed to Sr DGM/CMM, Vendor Complex, BHEL, Hyderabad and sent by appropriate mode to above address or dropped in tender box located at vendor complex on or before the specified time and date of submission of offers, preferably in the bidder's envelope. E- mail bids shall be sent to mail ID <a href="mailto:pricebid_hyd@bhel.in">pricebid_hyd@bhel.in</a> only as an attachment.   | <b>Non Deviatable</b> |
| <b>B.</b> | <b>For two-Part Bids:</b>   |                       |
| i         | <p>The offer is to be submitted in two parts viz.,<br/>         Techno-commercial Bid - (Part-I), with all technical specification &amp; scope including bill of material etc., Earnest Money Deposit (EMD)(wherever applicable) and unpriced bid with all applicable Commercial Terms and Conditions, rates of agency commission, duties, taxes and other charges, Signed and Stamped ITB and SCC, <u>except the price</u>, shall be kept in a separate sealed cover, superscribing enquiry No. (Techno-Commercial Bid) and due date<br/> <b>AND</b><br/>         Price Bid (Part-II), containing ONLY the price (including agency commission, if any) and the applicable duties/taxes/other charges shall be kept in a separate sealed cover superscribing Enquiry no. (Price bid) &amp; due date.</p> <p>Both the above covers (Part –I &amp; II) shall be kept in a Third cover superscribing Enquiry no. &amp; due date.</p> <p>Bidder can also submit offer through email. Technical offer to be submitted to mail ID <a href="mailto:technicalbid_hyd@bhel.in">technicalbid_hyd@bhel.in</a>, and price bid to be submitted to mail ID <a href="mailto:pricebid_hyd@bhel.in">pricebid_hyd@bhel.in</a> only as an attachment. Interchanging the information in the mails may lead to rejection of the offer. Bidder shall have no claim on e-mail offers sent to any other e-mail ID.</p> <p>In case of e-mail offers, the mail subject should contain Enquiry Number, Due date and Bidder name. Bidder address including contact details shall be mentioned in the content of the mail. Without these details, the offer is liable for rejection.</p> <p>All techno commercial terms &amp; conditions mutually agreed prior to price bid opening shall prevail and supersede any terms and conditions specified otherwise in price bid.</p> | <b>Non Deviatable</b> |
| ii        | The bidders whose bids are techno commercially not accepted will be informed and EMD shall be returned wherever submitted.  |                       |
| iii       | Bidders will be allowed to submit the impact on their quoted prices due to changes in technical scope, specifications, and commercial terms/conditions as specified in NIT which in the opinion of BHEL , warrant changes in prices.  | <b>Non Deviatable</b> |
| <b>C</b>  | Bids shall be opened on due time and date in the presence of bidders who may like to be present. Only one representative of each bidder shall be permitted to attend the bid opening. Only the price bids of bidder (in case of two part bid) whose techno commercial bids are accepted will be opened later on a specified date.   | <b>Non Deviatable</b> |
| <b>6</b>  | <b>DELIVERY TERMS</b>   |                       |
| <b>A</b>  | <b>Indigenous Purchase</b>  |                       |
|           | <p>a. Terms of Delivery for dispatches to BHEL Hyderabad (HPEP) shall be FOR Destination.</p> <p>b. Terms of Delivery for Direct Dispatch (DD) items shall be Ex Works.<br/>         i. In case specified in SCC that insurance is in customer/BHEL scope, price quoted shall include Freight charges up to Destination.<br/>         ii. Otherwise, price quoted shall include Freight and Insurance upto Destination. However, beneficiary for insurance shall be BHEL.</p>   |                       |
| <b>B.</b> | <b>Imports</b>  |                       |
|           | The goods shall be delivered on FCA capital airport basis in case of freight by Air and CIP basis in case of freight by Sea.  |                       |
| <b>7</b>  | <b>Documentation for Payment</b>  |                       |
| <b>A</b>  | <b>Indigenous Purchase</b>  |                       |
|           | <p>Following documents shall be submitted immediately on dispatch of material to BHEL HPEP / Site</p> <p>a. Original Tax Invoice (Refer ITB clause no 11 for Tax Compliance)<br/>         b. Packing List - clearly showing number of packages, gross weight and net weight.<br/>         c. Test/Warranty/Guarantee certificates, O&amp;M Manual (If specified in SCC)<br/>         d. Insurance intimation/declaration certificate<br/>         e. Pre-dispatch Inspection report /Third Party Inspection Certificates.<br/>         f. Consignee copy of LR signed &amp; stamped by Customer/Site representative for DD Items<br/>         g. e-waybill<br/>         h. Any other documents as specified in SCC.</p> <p>Softcopies of the above documents shall be uploaded in Pradan portal <a href="https://hpep.bhel.com/mm">https://hpep.bhel.com/mm</a> immediately after dispatch of the material.</p>   | <b>Non Deviatable</b> |

| <b>B</b> | <b>Imports</b>                       | <p>i) Bidder shall inform BHEL the readiness of material along with packing details 30 days in advance from the date of delivery.</p> <p>ii). Bidder shall also upload the soft copy of the dispatch documents consisting of BL / AWB, Invoice, delivery note, packing list, country of origin &amp; Test certificates and other documents as specifically indicated in the SCC in PRADAN Portal (<a href="https://hpep.bhel.com/mm">https://hpep.bhel.com/mm</a>) within Five days from the B/L date for sea shipment and One day from AWB date for Air shipment and sent to email ids: mssea@bhel.in, msair@bhel.in, cmmfe@bhel.in.</p> <p>iii) AWB/BL must contain the information of BHEL GST no., and PAN no.</p> <p><b>iv) Air Shipments:</b><br/>Bidder shall ensure the following</p> <p>a) Port of discharge -- Mumbai/Chennai/Hyderabad (as indicated in SCC).</p> <p>b) Consignee shall be BHEL, Hyderabad. Material shall be air freighted through cargo mode only and not through Courier.</p> <p>c) Upon handing over the cargo to the forwarder, bidder shall ensure the acknowledgement receipt with wordings" Cargo handed over in sound condition for Air freighting".<br/>Note: Warehouse receipt will not be considered for penalty calculations.</p> <p>d) In case of CIF/ shipments, bidder shall also inform BHEL the information about discharge port agent details and cargo arrival information within one day from the date of Shipment.</p> <p>e) Following dimensions of single package may be noted.</p> <p>i). Maximum dimension of the cargo(ODC) -- 125" x 88" x 63"</p> <p>ii). Maximum weight of the cargo -- 3.5 MT.</p> <p>If any package dimension or weight exceeds the above set limits, it will be treated as Over Dimension Cargo (ODC) or Over Weight Cargo and bidder shall inform BHEL 30 days in advance to the delivery date to enable BHEL to finalize the freight forwarder.</p> <p>f). If package falls under Hazardous category, bidder shall communicate BHEL 30 days in advance period with document support.</p> <p><b>v) Sea Shipments:-</b><br/>bidder shall ensure the following</p> <p>a). Port of discharge -- Nhavaseva/Mumbai/Chennai.</p> <p>b). Place of Delivery / Final Destination for CIP shipments - Nhavaseva CFS / Chennai CFS.</p> <p>c). In case of FOB shipments, bidder shall handover the material to BHEL nominated forwarder and obtain the cargo receipt.</p> <p>d). If the material cannot be containerised in 20 or 40 GP containers, an advance information of 30 days prior to the delivery date shall be communicated to BHEL for necessary arrangements and finalisation of freight forwarder.</p> <p><b>e). For CIP shipments</b></p> <p>1. In case of FCL shipments, Detention free period must be 14 days.</p> <p>2. Bidder shall also inform BHEL the information about discharge port agent details and cargo arrival information within 5 days from the date of Shipment.</p> <p>3. No charges for the services rendered till place of destination will be payable by BHEL. In case liner / forwarder insist for charges, not in the scope of BHEL, the same will be adjusted from bidder account.</p> <p>4. In case of CIF shipments -- Bidder must select a forwarder/liner whose discharge port published tariff for THC and other services is available. Any charges over and above the published tariff will not be borne by BHEL or will be adjusted from the bidder's bill.</p> <p>5. bidder must insure the cargo for 110% of material value including the freight amount.</p> <p>(vi). Recovery charges for non-submission of documents: -<br/>Bidder shall submit all the required documents to BHEL as prescribed in the Purchase order and NIT.</p> <p>If BHEL incurs any charges such as Penalty, demurrage, container detention, wharfage, storage, Ground rent etc., due to non - compliance / non - submission of documents prescribed in Purchase Order/ NIT/Letter of credit, the same shall be recovered from the bidder as under:</p> <p>1. EUROPE/USA/Black Sea/ Far East/Middle East/South East sector</p> <p><b>A. For FOB Sea Consignments:-</b></p> <p>Penalty for late submission / negotiation of documents beyond 14 days shall be as under:</p> <table border="1" style="width: 100%; border-collapse: collapse;"> <thead> <tr> <th rowspan="2">Sl. no</th> <th rowspan="2">Period (From Date of Bill of Lading)</th> <th colspan="3">Recoverable Charges</th> </tr> <tr> <th>Recoverable Charges</th> <th colspan="2">Recoverable Charges per day per container</th> </tr> <tr> <th></th> <th></th> <th>LCL per week/<br/>Break bulk cargo per day</th> <th>20FT Container</th> <th>40FT Container</th> </tr> </thead> <tbody> <tr> <td style="text-align: center;">i</td> <td style="text-align: center;">Upto 14th day</td> <td style="text-align: center;">Nil</td> <td style="text-align: center;">Nil</td> <td style="text-align: center;">Nil</td> </tr> <tr> <td style="text-align: center;">ii</td> <td style="text-align: center;">15th day onward</td> <td style="text-align: center;">USD 10</td> <td style="text-align: center;">USD 110</td> <td style="text-align: center;">USD 200</td> </tr> </tbody> </table> | Sl. no                                    | Period (From Date of Bill of Lading) | Recoverable Charges |  |  | Recoverable Charges | Recoverable Charges per day per container |  |  |  | LCL per week/<br>Break bulk cargo per day | 20FT Container | 40FT Container | i | Upto 14th day | Nil | Nil | Nil | ii | 15th day onward | USD 10 | USD 110 | USD 200 |
|----------|--------------------------------------|--|---|--------------------------------------|---------------------|--|--|---------------------|---|--|--|--|---|----------------|----------------|---|---------------|-----|-----|-----|----|-----------------|--------|---------|---------|
| Sl. no   | Period (From Date of Bill of Lading) | Recoverable Charges  |   |                                      |                     |  |  |                     |   |  |  |  |   |                |                |   |               |     |     |     |    |                 |        |         |         |
|          |                                      | Recoverable Charges  | Recoverable Charges per day per container |                                      |                     |  |  |                     |   |  |  |  |   |                |                |   |               |     |     |     |    |                 |        |         |         |
|          |                                      | LCL per week/<br>Break bulk cargo per day  | 20FT Container                            | 40FT Container                       |                     |  |  |                     |   |  |  |  |   |                |                |   |               |     |     |     |    |                 |        |         |         |
| i        | Upto 14th day                        | Nil  | Nil                                       | Nil                                  |                     |  |  |                     |   |  |  |  |   |                |                |   |               |     |     |     |    |                 |        |         |         |
| ii       | 15th day onward                      | USD 10   | USD 110                                   | USD 200                              |                     |  |  |                     |   |  |  |  |   |                |                |   |               |     |     |     |    |                 |        |         |         |



|           |   |  |                       |
|-----------|---|--|-----------------------|
|           | <p><b>B. For CIP Sea Shipments: -</b><br/>         Bidder shall provide rates for detention charges after free period at the time of offer itself in case of engagement of 20FT Container and 40FT category. In case of late presentation of documents to the bank recovery will be effected from the Bidder as per the rates quoted by the Bidder at the time of offer in this regard.<br/>         In case of Break bulk cargo and LCL, Demurrage charges shall be recovered at the rate of USD 1 per Ton per day and storage charges at the rate of USD 10 per week respectively shall be charged as late presentation charges.</p> <p>(vii) Description of items in invoice, packing list, BL / AWB or LR shall be same as PO item description. Bidders shall ensure that invoice shall contain PAN nos. of both bidder and BHEL along with other tax related numbers. BHEL PAN AAACB4146P and BHEL TAN HYDB00086C Any other additional documents sought by the statutory authorities, the same shall be produced by the bidder on priority basis.<br/>         (viii) Bidder shall provide package details including number of packages, gross weight, net weight etc.</p> <p>(ix) The bidder shall provide the following documents at the time of submission of offer:<br/>         a) No Business Connection in India declaration issued by the bidder as per the format specified. (or)<br/>         b) (i) No Permanent Establishment in India declaration issued by the bidder as per the format specified.<br/>         (ii) Tax Residence Certificate issued by the bidder's tax authorities.<br/>         (iii) Form 10F, as attached in Annexure V, to be issued by the bidder.<br/>         c) In case the bidder has a Business Connection in India as per Section 9 of Income Tax Act or significant economic presence in India as per rule 11 UD of IT Act or Permanent Establishment in India as per Article 5 of Double Taxation Avoidance Agreement between India and the bidder's country, the bidder shall provide a withholding tax order issued by the Indian Income Tax authority for recovery of applicable tax.</p> |  |                       |
| <b>8</b>  | <b>Delivery Schedule</b>  |  |                       |
|           | <p>The tendered goods shall be delivered within the period stipulated in NIT/ SCC as accepted. Inordinate delay/early supply are liable for rejection/ Hold on payment.</p>   |  | <b>Non Deviatable</b> |
| <b>9</b>  | <b>Pricing Terms</b>  |  |                       |
|           | <p>Quoted price shall be inclusive of Packing &amp; Forwarding and shall remain firm and valid during the execution of PO. Offers with PVC will be rejected outright except in cases where specifically called for in the SCC.</p>  |  | <b>Non Deviatable</b> |
| <b>10</b> | <b>PRICE VALIDITY :</b>   |  |                       |
|           | <p>Unless otherwise specified, offer shall be valid for a period of 90 days from the date of bid opening (Technical bid /part-I in case of two part bid).<br/>         However the prices quoted for spare parts of the Main equipment shall be kept valid for a period as specified in SCC.</p>  |  | <b>Non Deviatable</b> |
| <b>11</b> | <b>Taxes &amp; Duties (RATE TO BE INDICATED by the bidder against the space provided )</b>  |  |                       |
| <b>A</b>  | <p><b>Indigenous Purchase</b></p> <p>i) Only valid GST registered bidders will be considered for the tender. The GSTIN of the bidder should be clearly mentioned in the offer.<br/>         ii) If bidder is exempted from GST registration under any provision of the GST Law, a declaration with due supporting documents should be furnished for considering the offer.<br/>         iii) Bidder to quote the applicable taxes in the following manner:<br/>         - Harmonized System of Nomenclature (HSN) of Goods<br/>         - Services Accounting Code(SAC) of Services.<br/>         - IGST/CGST/SGST/UTGST: Rate of Tax to be quoted as extra in % against the space provided<br/>         iv) Bidders to ensure correct applicability of IGST/CGST/SGST/UTGST based on the Inter / Intra state movement of goods/services.<br/>         v) In case Bidder has opted for GST Composition Scheme, the same may be stated explicitly both in their technical and price bids. An undertaking to the effect that any change in the status of the bidder will be intimated.<br/>         vi) Any other taxes &amp; duties not covered anywhere above may be indicated separately.</p> <p><b>Taxes deducted at source:</b><br/>         - TDS as per the extant statutes shall be deducted.<br/>         - In case bidder does not provide PAN details, higher rate of tax shall be deducted as per the Act.<br/>         - Concessional certificates, if any, should be provided well in time for lower deduction of tax.</p>  |  | <b>Non Deviatable</b> |



|   |                       |
|---|-----------------------|
| <p><b>Terms &amp; Conditions to be complied</b></p> <ol style="list-style-type: none"> <li>1. All invoices (incl. Credit Notes, Debit Notes) to contain BHEL HPEP GSTIN ie 36AAACB4146P1ZG. Invoices submitted should be in the format as specified under GST Law. All details as mentioned in Invoice Rules including Dealer GST registration number (GSTIN), invoice number with date of issue, quantity, rate, value, taxes with nomenclature – CGST, SGST, UGST, IGST mentioned separately, HSN Code / SAC Code etc.</li> <li>2. Reimbursement of GST amount will be made only upon completion of the following:             <ol style="list-style-type: none"> <li>i. Bidder declaring such invoice in their GSTR-1 Return/ IFF</li> <li>ii. Receipt of Goods or Services and Submission of Tax invoice by BHEL</li> <li>iii. The tax invoice is reflected in the GSTR2B of BHEL, HPEP (buyer). Payment of GST will be made only if it is matching with data uploaded by the Bidder in GST portal.</li> </ol> </li> <li>3. In case of discrepancy in the data uploaded by the bidder in the GSTN portal vis-a-vis the tax invoice or in case of any shortages or rejection in the supply, then BHEL will not be able to avail the tax credit. The same would be available in PRADAN Portal for the bidder's information. Bidder has to rectify the data discrepancy in the GSTN portal or issue credit note or debit note (details also to be uploaded in GSTN portal) for the shortages or rejections in the supplies or additional claims for processing of such invoices.</li> <li>4. In cases where invoice details have been uploaded by the bidder but failed to remit the GST amount to GST Department within stipulated time, then GST on the invoices in default will be recovered from the bidder along with the applicable interest.</li> <li>5. In case GST credit is delayed/denied to BHEL due to non/delayed receipt of goods and/or tax invoice or expiry of timeline prescribed in GST law for availing such ITC, or any other reasons not attributable to BHEL, such GST amount will be recoverable from bidder along with interest levied/leviable on BHEL.</li> <li>6. Under GST regime, BHEL has to discharge GST liability on LD recovered from bidders. Hence applicable GST shall also be recoverable from bidders on LD amount. For this Tax Invoice digitally signed will be issued by BHEL indicating the respective supply invoice number. The same can be downloaded from PRADAN Portal.</li> <li>7. GST TDS deducted as per GST Act, is uploaded in GSTN portal along GSTR7. Bidders can directly download the GST TDS Certificate from the GSTN Portal.</li> <li>8. Bidders to note that Rules &amp; Regulations pertaining to E-way bill system are to be strictly adhered to, as and when notified by Govt. authorities.</li> </ol> |                       |
| <p><b>B. Foreign Purchase ( Imports )</b></p> <p>The offered price shall be inclusive of all the Taxes and duties as applicable in country of export / country of dispatch for the quoted price.</p> <p>Taxes deducted at source:</p> <ol style="list-style-type: none"> <li>a. In case of goods or services subject to Income tax in India, such tax as per the extant statute shall be recovered.</li> <li>b. In case bidder does not provide necessary documents for beneficial taxation (Refer clause 7-B-(ix) a-c of ITB), the TDS deduction shall be at the maximum percentage stipulated as per the provisions of Income Tax Act.</li> </ol>   | <b>Non Deviatable</b> |
| <p><b>12 Payment Terms: Unless otherwise specified in SCC, following shall be the terms of Payment.</b></p>   |                       |
| <p><b>A Indigenous:</b></p> <ol style="list-style-type: none"> <li>a. Micro &amp; Small Enterprises (MSEs) - 100% Direct EFT payment within 45 days</li> <li>b. Medium Enterprises - 100% Direct EFT payment within 60 days</li> <li>c. Non MSME Bidders - 100% direct EFT Payment within 90 Days</li> </ol> <p>Note</p> <ol style="list-style-type: none"> <li>A. Above due date is reckoned from the date of Receipt of material or 15 days from the date of submission of complete set of documents as per PO whichever is later. Payment will be made on acceptance of Material.</li> <li>B. MSEs (covered under MSME Act) need to register and renew periodically and update the same with BHEL</li> <li>C. The taxes that are reimbursed are limited to applicable taxes as on the Purchase Order delivery date or the amount actually paid whichever is less.</li> <li>D. Adherence to the above time schedule of payment is contingent upon Bidder complying with GST provisions and availment of Input Tax Credit by BHEL before the date of payment.</li> <li>E. In case of packaged items, 10% of supply value will be retained till completion of total supplies.</li> <li>F. Bidders to comply with <b>clause 11</b> on GST requirements</li> </ol>  |                       |
| <p><b>B Imports:</b></p> <ol style="list-style-type: none"> <li>i) 100% payment (less Indian Agency Commission, if any) shall be through Wire Transfer with a credit period of 60 days - Cash Against Documents (CAD)</li> <li>ii) In case Bidder opts for Letter of Credit payment, the LC Usance period shall be 90 days with respective bank charges to respective accounts and loading of 0.50%</li> <li>iii) Indian Agency commission if payable and so specified in the Purchase order shall be paid in Indian Rupees, considering the SBI TT selling exchange rate, as on the date of payment after successful completion of the contract.</li> </ol>  |                       |



|    |   |                   |
|----|---|-------------------|
| C  | <p><b>Conditions for both Inland &amp; Foreign LC:</b></p> <p>a. LC validity period will be 90 days and for any extension, applicable charges will be to bidder's account.</p> <p>b. LC will be opened 7 working days after receipt of request along with successful pre dispatch inspection completion report / material readiness intimation with Material Test Certificate (MTC), prior to the scheduled / agreed delivery date.</p>   | Non<br>Deviatable |
| D  | <p><b>Conditions for both Indigenous &amp; Foreign Bidders:</b></p> <p>a. In case Bidders insist for lesser Credit period, loading of 0.60% for every 15 days reduction will be applicable.</p> <p>b. In case PBG as required is not furnished, Payment will be released deducting the BG amount, which will be paid after expiry of warranty period against submission of supplementary claim.</p> <p>c. Payment does not imply in any respect whatsoever a waiver of Buyer's right to performance of the Order. Buyer is entitled to set off claimable debts against claimable liabilities with the bidder by means of a setoff Note.</p>   | Non<br>Deviatable |
| E  | <p>Wherever EMD is applicable, the EMD will be paid back to unsuccessful bidders within fifteen days after award of the contract. Successful bidder's EMD will be retained till submission of Performance Bank Guarantee (PBG).</p> <p>Tender Fee wherever applicable is not refundable.</p> <p>No interest shall be payable by BHEL on earnest money or security deposit or any money due to the contractor by BHEL.</p>   | Non<br>Deviatable |
| 13 | <p><b>Penalty clause:</b></p>   |                   |
|    | <p>In the event of delay in supply /part-supply of goods, Penalty as detailed below is leviable</p> <p>a. Penalty of 0.5% per week or part there of shall be levied, limited to a max of 10% (ten percent) of delayed portion value / order value (as specified in SCC).</p> <p>b. Penalty applicable for delay in documentation is as per SCC.</p> <p>c. Date Reckoned for Penalty</p> <ul style="list-style-type: none"> <li>- Indigenous Orders with delivery terms FOR HPEP: C Note date.</li> <li>- Indigenous Orders (Others): Date of e-waybill.</li> <li>- Imports: For CIP/CIF Orders: IGM date</li> <li>- Imports: For FOB Orders: AWB / BL date</li> <li>- Imports: For FCA/Ex Work Orders: Date of acknowledgement from Freight Forwarder.</li> </ul> <p>d. In case of Deviation to above Penalty clause, loading applicable to the extent to which not agreed by Bidder.</p> <p>e. Timelines as mentioned in the Annexure 1 will be considered for reckoning delivery.</p> <p>Penalty amount so determined along with applicable GST (for Indigenous orders) thereon shall be recovered.</p> <p>Imposition, recovery or settlement of this penalty shall not affect BHEL's right to performance, compensation and termination of the order.</p>  |                   |
| 14 | <p><b>Excess materials</b> supplied beyond tolerance limit as specified in PO will not be paid and bidder may raise credit note for the excess/unaccepted material as per GST law.</p>  | Non<br>Deviatable |
| 15 | <p><b>Rejected materials</b>, if any, shall be collected by the bidder within 90 days of such communication to the bidder. Beyond this period the bidder forfeits their right to the materials.</p>   | Non<br>Deviatable |
| 16 | <p><b>Guarantee / Warranty Period:</b></p> <p>Wherever required, and so provided in the specifications/SCC/Purchase Order, the bidder shall guarantee that the goods supplied shall comply with the specifications laid down, for materials, workmanship and performance.</p> <p>a. Guarantee period shall be 12 months from the date of commissioning or 18 months from the date of supply whichever is earlier.</p> <p>b. In case erection &amp; commissioning is involved, guarantee period shall be 12 months from the date of commissioning.</p> <p>c. In case of equipment bought as a package which are intended to be incorporated in installations or systems, the guarantee period shall be 12 months from the date of commissioning of such equipment.</p> <p>The guarantee period shall be extended by the period during which the goods are not in compliance. If the delivery is found to be non-complaint, bidder shall replace, repair or re-execute the as requested by BHEL. If the bidder defaults on his obligations, buyer has the right to proceed to replace, repair or re-execute at the bidder's expense.</p> <p>A guarantee period as described above shall apply afresh to replaced, repaired or re-executed parts of a delivery.</p> <p><b>Loading for deviation:</b></p> <p>In case warranty specified in SCC is over and above the period mentioned in b &amp; c above; loading will be 1% per annum for the deviation in warranty end period, on the contract value. Expected commissioning period is as indicated in SCC.</p> | Non<br>Deviatable |

| <b>17</b>   | <p><b>PERFORMANCE BANK GUARANTEE (PBG) (Applicable in case mentioned in SCC)</b></p> <p>In case enquiry specifically spells out PBG requirement, PBG is to be submitted by Bidder in requisite format as per Annexure VII.<br/>Further detailing on PBG as specified in SCC.<br/>The PBG shall be for the performance of the goods and shall remain binding not withstanding such variations, alterations or extensions of item as may be made, give, conceded or agreed to between the Bidder and BHEL under these Terms and conditions or otherwise.</p>   | <b>Non<br/>Deviatable</b> |         |          |          |         |     |                                      |    |  |  |  |                                     |    |    |  |  |                                   |       |       |       |  |   |    |    |    |    |
|---|--|---------------------------|---------|----------|----------|---------|-----|--------------------------------------|----|--|--|--|-------------------------------------|----|----|--|--|-----------------------------------|-------|-------|-------|--|---|----|----|----|----|
| <p><b>NOTE: Deviations (Commercial as well as Technical) from the tender specifications and conditions are generally not acceptable. However, deviation if any, shall be brought out clearly with proper justification in the offer. The deviation, if considered by BHEL, shall be loaded for comparison, while evaluating the offer. If a bidder unconditionally withdraws any deviation before price bid opening, the same shall not be loaded. Loading criteria in respect of major commercial conditions where deviations if any are accepted shall be as per clause No.18. The Bidders may specifically note the following.</b></p> |  |                           |         |          |          |         |     |                                      |    |  |  |  |                                     |    |    |  |  |                                   |       |       |       |  |   |    |    |    |    |
| <b>18</b>   | <p><b>Evaluation and Loading Criteria:</b></p> <p>i) Evaluation Currency for this tender shall be "INR".<br/>ii) Evaluation of prices shall be done item-wise unless otherwise specified in the SCC.<br/>iii) Evaluation shall be on the basis of delivered cost, i.e. "Total Cost to BHEL" w.r.t the finalized technical scope and commercial conditions (after considering incidence of applicable taxes and duties and loading).<br/>iv) In the course of evaluation, if more than one Bidder happens to occupy L1 status, effective L1 will be decided by soliciting discounts from the respective L1 Bidders. In case more than one Bidder happens to occupy the L1 status even after soliciting discounts, the L1 Bidder shall be decided by a toss/draw of lots, in the presence of the respective L1 Bidders or their representatives. Ranking will be done accordingly. BHEL decision in such situations shall be final and binding.</p> <p><b>INDIGENOUS</b></p> <p>a. Bidder shall ensure to indicate the applicable taxes against each line item, failing which the same will be considered as inclusive/NIL.<br/>b. Ex-works offers received (as against FOR Destination mentioned in enquiry) shall be loaded by 2% of Ex-works value.<br/>c. GST and any other charges quoted will be added to the base price. However, in case input credit is available for GST (SGST, CGST/IGST), the same shall be excluded for arriving at "Total Cost to BHEL"</p> <p><b>IMPORTS</b></p> <p>For evaluation of offers in foreign currency, exchange rate (TT selling rate of State Bank of India) as on the date of bid opening (Part-I, in case of two-part bids) shall be considered. If the relevant day happens to be a bank holiday, then the forex rate as on the previous bank (SBI) working day shall be taken.<br/>In case of foreign Bidders, the quoted CIP price shall be loaded by the following factors to arrive at "Total Cost to BHEL":<br/>- Import duty as applicable on the date of Part-I bid opening.<br/><br/>- Loading will be as per the table below</p> <table border="1" style="width: 100%; border-collapse: collapse;"> <thead> <tr> <th></th> <th>Ex Works</th> <th>FOB/FC A</th> <th>CIF/CFR</th> <th>CIP</th> </tr> </thead> <tbody> <tr> <td>Foreign Inland freight and insurance</td> <td style="text-align: center;">2%</td> <td></td> <td></td> <td></td> </tr> <tr> <td>Marine freight and marine insurance</td> <td style="text-align: center;">3%</td> <td style="text-align: center;">3%</td> <td></td> <td></td> </tr> <tr> <td>Destination Port handling charges</td> <td style="text-align: center;">0.50%</td> <td style="text-align: center;">0.50%</td> <td style="text-align: center;">0.50%</td> <td></td> </tr> <tr> <td>clearing charges &amp; inland freight and insurance</td> <td style="text-align: center;">2%</td> <td style="text-align: center;">2%</td> <td style="text-align: center;">2%</td> <td style="text-align: center;">2%</td> </tr> </tbody> </table> <p>COMMON LOADING FOR IMPORTS &amp; INDIGENOUS that will be added for arriving the "Total Cost to BHEL"<br/>A. Loading on Deviated Penalty clause shall be 10% or to the extent to which the bidder has opted for deviation.<br/>B. Loading for payment terms as per clause 12 of ITB<br/>C. Loading for deviation in Warranty &amp; PBG as per clause 16,17.</p> |                           |         | Ex Works | FOB/FC A | CIF/CFR | CIP | Foreign Inland freight and insurance | 2% |  |  |  | Marine freight and marine insurance | 3% | 3% |  |  | Destination Port handling charges | 0.50% | 0.50% | 0.50% |  | clearing charges & inland freight and insurance | 2% | 2% | 2% | 2% |
|   | Ex Works   | FOB/FC A                  | CIF/CFR | CIP      |          |         |     |                                      |    |  |  |  |                                     |    |    |  |  |                                   |       |       |       |  |   |    |    |    |    |
| Foreign Inland freight and insurance  | 2%   |                           |         |          |          |         |     |                                      |    |  |  |  |                                     |    |    |  |  |                                   |       |       |       |  |   |    |    |    |    |
| Marine freight and marine insurance   | 3%   | 3%                        |         |          |          |         |     |                                      |    |  |  |  |                                     |    |    |  |  |                                   |       |       |       |  |   |    |    |    |    |
| Destination Port handling charges   | 0.50%  | 0.50%                     | 0.50%   |          |          |         |     |                                      |    |  |  |  |                                     |    |    |  |  |                                   |       |       |       |  |   |    |    |    |    |
| clearing charges & inland freight and insurance   | 2%   | 2%                        | 2%      | 2%       |          |         |     |                                      |    |  |  |  |                                     |    |    |  |  |                                   |       |       |       |  |   |    |    |    |    |
| <b>19</b>   | <p>Procurement directly from the manufacturers/ suppliers shall be preferred. However, no agent shall be allowed to represent more than one manufacturer/ supplier in the same tender. Moreover, either the agent could bid on behalf of the manufacturer/ supplier or the manufacturer / supplier could bid directly but not both. In case bids are received from both from the manufacturer/ supplier and the agent, bid received from the agent shall be ignored.</p>   |                           |         |          |          |         |     |                                      |    |  |  |  |                                     |    |    |  |  |                                   |       |       |       |  |   |    |    |    |    |
| <b>20</b>   | <p><b>RIGHT OF REJECTION /NON- PLACEMENT OF PO:</b> BHEL reserves the right to accept or reject any or all bid/s in full or part without assigning any reason whatsoever.</p>  |                           |         |          |          |         |     |                                      |    |  |  |  |                                     |    |    |  |  |                                   |       |       |       |  |   |    |    |    |    |
| <b>21</b>   | <p><b>INTEGRITY PACT</b><br/>Bidders shall have to enter into Integrity Pact with BHEL as per Annexure VI - for Tender value of rupees two crores and above and shall be signed by the authorized signatory along with the offer, failing which Bidder's offer will be rejected.</p>   |                           |         |          |          |         |     |                                      |    |  |  |  |                                     |    |    |  |  |                                   |       |       |       |  |   |    |    |    |    |
| <b>22</b>   | <p><b>Public Procurement</b></p>   |                           |         |          |          |         |     |                                      |    |  |  |  |                                     |    |    |  |  |                                   |       |       |       |  |   |    |    |    |    |
| <b>A</b>  | <p><b>Make in India</b><br/>For this Procurement, the local content to categorize a bidder as a Class I local bidder / Class II local bidder / Non-Local bidder and purchase preference to Class I local bidder, is as defined in Public Procurement (Preference to Make in India) order No 45021/2/2017-PP(BE-II) dated 04-06-2020 issued by DPIIT as amended from time to time. P-<br/>Proforma for self-certification for minimum local content and auditor's certification is given in Annexure III.</p>   |                           |         |          |          |         |     |                                      |    |  |  |  |                                     |    |    |  |  |                                   |       |       |       |  |   |    |    |    |    |

|           |   |
|-----------|---|
| <b>B</b>  | Any Bidder from a country which shares a land border with India will be eligible to bid in this tender only if the bidder is registered with competent authority. GOI website <a href="https://www.mea.gov.in/">https://www.mea.gov.in/</a> to be referred for latest details of competent authority and exemptions . Proforma for self-certification for compliance is given in Annexure IV.   |
| <b>C</b>  | <b>Startups:</b><br>For Start-ups duly registered with DPIIT (Copy of certificate to be provided), condition of prior turnover and prior experience in Public Procurement may be relaxed subject to meeting of Quality and Technical Specifications. Startups are exempt from paying EMD.   |
| <b>23</b> | <b>Benefits earmarked for Purchase from Micro &amp; Small Enterprises (MSEs) – Indigenous Purchase</b>  |
| <b>A</b>  | All Micro and Small Enterprises (MSEs) as defined in MSE Procurement Policy are exempt from Paying EMD. NSIC/UDYAM registered bidders shall submit NSIC/UDYAM Certificate along with bid documents. Date to be reckoned for determining the deemed validity will be the last date of Technical bid submission. Non- submission of such document will lead to consideration of their bid, at par with other bidders and MSE status of such bidders shall be shifted to Non- MSE Category till the bidder submits these documents.  |
| <b>B</b>  | In tender, MSEs quoting price within price band of L1+15% shall also be allowed to supply a portion of requirement by bringing down their price to L1 price in a situation where L1 price is from someone other than a MSE and such MSE shall be allowed to supply at least 25% of total tendered value. In case of more than one such MSE, the supply shall be shared proportionately. Out of these 25% minimum 3% shall be earmarked for MSEs owned by women and 6.25% for MSEs owned by SC/STs who submit the relevant documents.  |
| <b>C</b>  | If an enterprise falling under MSME category as defined in the Act, graduates to a higher category from its original category or beyond the purview of the Act, it shall continue to avail all non-tax benefits of its original category notified by the Ministry of Micro, Small and Medium Enterprise for a period of three years from the date of such graduation to the higher category.  |
| <b>D</b>  | BHEL HPEP is registered with RXIL (TReDS) platform. MSME bidders are requested to get registered with RXIL (TReDS) platform to avail the facility as per the GOI guidelines.  |
| <b>24</b> | Inspection Measuring and Test Equipment (IMTE) used by the Bidder/ Contractor or sub-contractor shall be calibrated, maintained and controlled. Calibration shall be valid and IMTE maintained in sound condition during usage.   |
| <b>25</b> | ISO-9001, ISO14001 & OHSMS 45001 shall be complied.   |
| <b>26</b> | If BHEL registered supplier is not quoting against this NIT, supplier shall send regret letter positively with valid reasons for not participating. Repeated lack of response on the part of supplier may lead to deletion of such registered supplier from BHEL's approved supplier's list as per BHEL SEARP Guidelines.   |
| <b>27</b> | <b>Risk Purchase clause:</b><br>In case bidder fails/delays to supply whole or part of the ordered items or supplies defective items or fails to fulfil any other terms and conditions given in Purchase Order/Contract, BHEL has the right to terminate the order/contract or withdraw balance scope of work/supply and make the purchase of such material / services from elsewhere at the risk and cost of the defaulted bidder.<br>The bidder is liable for the additional expenditure / difference in Cost, if any, including consequential losses which BHEL may sustain by reason of risk purchase in addition to the applicable LD as per the order/contract.<br>Non-performance of contract attracts penal provisions in line with BHEL guidelines for Suspension of Business Dealings (SBD).  |
| <b>28</b> | Any other terms and conditions of the bidder attached / referred against the tender enquiry will not be considered.   |
| <b>29</b> | All drawings, patterns and tools supplied by BHEL or made at BHEL's expense are BHEL's property. These cannot be used or referred to any other party and must be used only in the execution of BHEL's orders.   |
| <b>30</b> | Any amount payable by the bidder under any of the conditions of this contract shall be liable to be adjusted against any amount payable to the bidder under any other work / contract awarded by BHEL HPEP or any other BHEL Units. This is without prejudice to any other action as may be deemed fit by BHEL.   |
| <b>31</b> | The bids of the bidders who are on the banned list and also the bids of the bidders, who engage the services of the banned firms, will be rejected. The list of firms banned by BHEL is available on BHEL web site: <a href="http://www.bhel.com">www.bhel.com</a>  |
| <b>32</b> | <b>Ordering and confirmation of order</b>   |
|           | The bidder shall send the order acceptance within one week from the date of LOI/Purchase order or such other period as specified/agreed by the Buyer. Buyer reserves the right to revoke the order placed if the order confirmation differs from the original order placed. Buyer shall be legally bound, only if agreed for any deviation explicitly in writing. The acceptance of deliverables or supplies by Buyer as well as payments made in this regard shall not imply acceptance of any deviations.<br>The Purchase order will be deemed to have been accepted if no communication to the contrary is received within one week (or the time limit as specified /agreed by the Buyer) from the date of P.O.<br>Buyer, is at liberty to send signed P.O. through electronic media such as e-mail and the receipt of which shall be treated as receipt of order. |
| <b>33</b> | <b>Execution</b>  |
|           | The whole contract is to be executed in the most workman like manner, substantial and approved as per the contracted terms.   |
| <b>34</b> | <b>Progress Report</b>  |
|           | The bidder shall render such report as to the progress of work and in such form as may be called for by the Buyer from time to time. The submission and acceptance of such reports shall not prejudice the rights of the buyer in any manner. Bidder shall communicate to BHEL immediately, the change of address, ownership, contact person(s), the mobile numbers and e-mail of the dealing person concerned.<br>Milestones shall be periodically updated by bidder through PRADAN Portal ( <a href="https://hpep.bhel.com/mm/">https://hpep.bhel.com/mm/</a> ). Non updation will adversely affect service rating of bidder performance.   |

|           |  |
|-----------|--|
| <b>35</b> | <b>Non-disclosure Obligations</b>  |
|           | <p>Drawings, technical documents or other technical information received by one party shall not without the consent of the other party, be used for any other purpose than that for which they were provided. They may not, without the consent of the submitting party, otherwise be used or copied, reproduced, transmitted or communicated to third parties. All information and data contained in general product documentation, whether in electronic or any other form, are confidential and binding only to the extent that they are by reference expressly included in the contract.</p> <p>The bidder shall, as per agreed date/s but not later than the date of delivery, provide free of charge any information and/or drawings which are necessary to permit the Buyer to erect, commission, operate and maintain the product. Such information and drawings shall be supplied as specified in technical specification.</p> <p>All intellectual properties, including designs, drawings and product information etc. exchanged during the formation and execution of the contract shall continue to be the property of the submitting party.</p> <p>The bidder shall provide Buyer with all information pertaining to the delivery in so far as it could be of importance to Buyer. The bidder shall not reveal confidential information to its own employees not involved with the tender/contract and its execution and delivery or to third parties, unless Buyer has agreed to this in writing beforehand. The bidder shall not be entitled to use the Buyer's name in advertisements and other commercial publications including website without prior written permission from Buyer.</p> <p>In the event of violation of the confidentiality as agreed, BHEL will take legal action as deemed fit. Non-disclosure agreement to be entered as per <b>Annexure- II</b> wherever applicable.</p>  |
| <b>36</b> | <b>Inspection and Testing</b>  |
| <b>A</b>  | <p>The goods and stores shall be manufactured by approved quality system and each part/component may be inspected and tested by the Buyer prior to shipment and shall comply with relevant requirements. Buyer has the right to inspect at any stage during manufacture/ delivery.</p>   |
| <b>B</b>  | <p>Buyer or his authorized representative shall be entitled at all reasonable times during execution to inspect, examine and test at the bidder's premises the material and workmanship of all stores to be supplied under the contract, and if the part of the stores are being manufactured at other premises, the bidder shall obtain for buyer or his authorized representative permission to inspect, examine and test as if the said stores are being manufactured at the bidder's premises. Such inspection, examination and testing, if made shall not release the bidder from any obligation under the contract.</p> <p>For indigenous bidders all costs related to first inspection request shall be borne by the buyer and the cost of subsequent inspections due to non-readiness of material/rework/ rejections shall be borne by the bidder. In case of imports all inspection charges including third party inspections if any shall be borne by the bidder. The cost of inspection staff/third party specified by the Buyer shall be borne by bidder unless otherwise specifically agreed. If the contract provides for tests on the premises of the bidder or any of his sub-contractor/s, bidder shall be responsible to provide such assistance, labor, materials, electricity, fuels, stores, apparatus, instruments as may be required and as may be reasonably demanded to carry out such tests efficiently. Cost of any type test or such other special tests shall be borne by the bidder unless otherwise specifically agreed in the contract. The Bidder shall give the authorized representative of the buyer reasonable notice in writing of the date on and the place at which any stores will be ready for inspection/ testing as provided in the Contract. Annexure – I, may strictly be complied with for the time lines. Any delay in submission of the documents by the bidder will not alter the delivery date.</p> |
| <b>37</b> | <b>Quality and Condition of the Deliverables</b>   |
|           | <p>The bidder shall be responsible for compliance with applicable technical, safety, quality, environmental requirements and other regulations in relation to products, packaging and raw and ancillary materials.</p>   |
| <b>38</b> | <b>Packaging and Dispatch</b>  |
|           | <p>The bidder shall package the deliverables safely and carefully and pack them suitably in all respects considering the peculiarity of the material for normal safe transport by sea/air/rail/road to its destination suitably protected against loss, damage, corrosion in transit and the effect or tropical salt laden atmosphere. The packages shall be provided with fixtures/hooks and sling marks as may be required for easy and safe handling by mechanical means. Special packaging conditions/ environmental conditions as defined in the NIT shall be fully complied.</p> <p>Each package must be marked with consignee name, address, P.O. number, Package Number, gross weight &amp; net weight, dimensions (Lx B x H) and bidder's name. The packing shall allow for easy removal and checking of goods on receipt and comply with carrier's conditions of packing or established trade practices. Packing list for goods inside each package with P.O. item No. &amp; quantity must also be fixed securely outside the box to indicate the contents. If any consignment needs special handling instruction, the same shall be clearly marked with standard symbols/instructions. Hazardous material should be notified as such and their packing, transportation and other protection must conform to relevant regulations.</p>   |
| <b>39</b> | <b>Contract variations; Increase or decrease in the scope of supply</b>  |
|           | <p>Buyer may vary the contracted scope during execution due to exigencies of project requirement.</p> <p>If the bidder is of the opinion that the variation has an effect on the agreed price or delivery period, Buyer shall be informed of this immediately in writing along with technical details, and in the event of additional work, submit a quotation with regards to the price and period involved, as well as the effect this additional work will have on the other work to be performed by the bidder. Wherever unit rates are available in the contract, the same shall be applied to such additional work. The bidder shall not perform additional work before buyer has issued written instructions/amendment to the purchase order to that effect. The work which the bidder should have or could have anticipated in terms of delivering the service (s) and functionality (ies) as described in this agreement should be executed by the bidder without any price implication.</p> <p>In case of no change in the scope / technical specifications, bidder shall endeavor to keep the material ready and intimate the same to BHEL within the contractual delivery date, failing which, the delay if any will be attributed to supplier, and any upward price variation thereof for delivery at a later date is not admissible.</p>   |
| <b>40</b> | <b>Rejected/Short shipments/ warranty/guarantee replacements</b>   |
|           | <p>In case of any short shipment during initial supply which is subsequently dispatched by the bidder or any guarantee / warranty replacements shall be dispatched on "DDP-Delivered duty paid BHEL stores" basis for imported items and "FOR-BHEL Stores/designated destination" basis for indigenous items.</p>  |
| <b>41</b> | <b>Export Administration Regulations</b>   |
|           | <p>If a delivery includes such technology and / or supply that is subjected to the export regulations the bidder shall obtain due permissions, approvals, license etc.</p>   |



|           |   |
|-----------|---|
| <b>42</b> | <b>Force Majeure</b><br>The bidder shall not be considered in default if delay occurs due to causes beyond their control such as Acts of God, Natural calamities, Fire, Frost, Flood, Civil War, civil commotion, riot, Government Restrictions.<br>Only those causes that have duration of more than seven days shall be considered cause of force majeure. Notification to this effect duly certified by local chamber of commerce/statutory authorities with supporting documents shall be given by the bidder to BHEL by registered letter/courier service immediately without loss of time.<br>In the event of delay due to such causes the delivery schedule shall be extended for a length of time equal to the period of Force Majeure or at the option of BHEL the order may be cancelled. Such cancellation would be without any liability whatsoever on the part of BHEL.<br>In the event of such cancellation the bidder shall refund any amount advanced or paid to the bidder by BHEL and deliver back any material issued to him by BHEL and release facilities, if any provided by BHEL.  |
| <b>43</b> | <b>Non-waiver of Defaults</b><br>If any individual provision of the contract is invalid, the other provisions shall not be affected.  |
| <b>44</b> | <b>Settlement of Disputes</b><br>Except as otherwise specifically provided in the contract, all disputes concerning questions of the facts arising under the contract, shall be decided by the Buyer, subject to written appeal by the bidder to the buyer, whose decision shall be final.<br>Any disputes of differences shall to the extent possible be settled amicably between the parties thereto, failing which the disputed issues shall be settled through arbitration<br>The bidder shall continue to perform the contract, pending settlement of disputes(s).   |
| <b>45</b> | <b>Conciliation clause</b><br>CONCILIATION CLAUSE FOR CONDUCTING CONCILIATION PROCEEDINGS UNDER THE BHEL CONCILIATION SCHEME, 2018: The Parties agree that if at any time (whether before, during or after the arbitral or judicial proceedings), any Disputes (which term shall mean and include any dispute, difference, question or disagreement arising in connection with construction, meaning, operation, effect, interpretation or breach of the agreement, contract or the Memorandum of Understanding, penalty deduction, time extension), which the Parties are unable to settle mutually, arise inter-se the Parties, the same may, be referred by either party to Conciliation to be conducted through Independent Experts Committee to be appointed by competent authority of BHEL from the BHEL Panel of Conciliators.<br>The proceedings of Conciliation shall broadly be governed by Part-III of the Arbitration and Conciliation Act 1996 or any statutory modification thereof and as provided in Procedure in <a href="http://www.bhel.com/index.php/story_details?story=2454">http://www.bhel.com/index.php/story_details?story=2454</a> . The Procedure together with its Formats will be treated as if the same is part and parcel hereof and shall be as effectual as if set out herein in this ITB   |
| <b>46</b> | <b>ARBITRATION (WITH SOLE ARBITRATOR)</b><br>Except as provided elsewhere in this Contract, in case amicable settlement is not reached between the Parties, in respect of any dispute or difference; arising out of the formation, breach, termination, penalty deduction, validity or execution of the Contract; time extension, or, the respective rights and liabilities of the Parties; or, in relation to interpretation of any provision of the Contract; or, in any manner touching upon the Contract, then, either Party may, by a notice in writing to the other Party refer such dispute or difference to the sole arbitration . Sole arbitrator to be appointed by Head of the Unit - BHEL , HPEP .<br>The Arbitrator shall pass a reasoned award and the award of the Arbitrator shall be final and binding upon the Parties.<br>Subject as aforesaid, the provisions of Arbitration and Conciliation Act 1996 (India) or statutory modifications or re-enactments thereof and the rules made thereunder and for the time being in force shall apply to the arbitration proceedings under this clause. The seat of arbitration shall be Sangareddy / Hyderabad, Telangana. The language of arbitration shall be English and the documents shall be submitted in English.<br>The cost of arbitration shall initially be borne equally by the Parties subject to the final apportionment of the cost of the arbitration in the award of the Arbitrator.<br>Subject to the arbitration in terms of clause 45, the courts at Sangareddy, Telangana State shall have exclusive jurisdiction over any matter arising out of or in connection with this contract.<br>Notwithstanding the existence or any dispute or differences and/or reference for the arbitration, the Contractor shall proceed with and continue without hindrance the performance of its obligations under this Contract with due diligence and expedition in a professional manner except where the Contract has been terminated by either Party in terms of this Contract. |
|           | <b>ARBITRATION FOR CONTRACT WITH PUBLIC SECTOR ENTERPRISE (PSE) OR A GOVERNMENT DEPARTMENT</b><br>In the event of any dispute or difference relating to the interpretation and application of the provisions of commercial contract(s) between Central Public Sector Enterprises (CPSEs/ Port Trusts inter se and also between CPSEs and Government Departments/Organizations (excluding disputes concerning Railways, Income Tax, Customs & Excise Departments), such dispute or difference shall be taken up by either party for resolution through AMRCD as mentioned in DPE OM No 4(1)/2013-DPE(GM/FTS 1835 dated 22-05-2018  |
| <b>47</b> | <b>Applicable Laws and jurisdiction of Courts</b><br>This agreement shall be construed and interpreted in accordance with the laws of India and shall have exclusive jurisdiction of Sangareddy/Hyderabad courts, Telangana, India.   |
| <b>48</b> | <b>BHEL-Fraud prevention policy shall be adhered to.</b><br>The Bidder along with its associate/ Collaborators/ Sub-contractors/ sub-bidders/ consultants/ service providers shall strictly adhere to BHEL Fraud Prevention policy displayed on BHEL Website <a href="http://www.bhel.com">http://www.bhel.com</a> and shall immediately bring to the notice of BHEL management about any fraud or suspected fraud as soon as it comes to their notice.<br>List of nodal officers is hosted on BHEL Hyderabad website <a href="https://hpep.bhel.com/">https://hpep.bhel.com/</a> .   |
| <b>49</b> | <b>Suspected Cartel Formation</b><br>The Bidder declares that they will not enter into any illegal or undisclosed agreement or understanding, whether formal or informal with other Bidder(s). This applies in particular to prices, specifications, certifications, subsidiary contracts, submission or non-submission of bids or any other actions to restrict competitiveness or to introduce cartelization in the bidding process. In case , the Bidder is found having indulged in above activities, suitable action shall be taken by BHEL as per extant policies / guidelines  |

Note: Purchase officer has to fill Annexure-I while sending enquiry