

	TECHNICAL SPECIFICATION & DATA SHEET FOR CONTROL VALVE WITH ACCESSORIES (PNEUMATICALLY OPERATED)	Specification No.: PE-TS-497-145-H104
		Rev. No. 00
		Date : 04.10.23

TECHNICAL SPECIFICATION

FOR
CONTROL VALVES
WITH ACCESSORIES (OTHER THAN FDV-14)
2 X 660 MW TALCHER THERMAL POWER PLANT

SPECIFICATION No. PE-TS-497-145-H104



BHARAT HEAVY ELECTRICALS LIMITED
POWER SECTOR
PROJECT ENGINEERING MANAGEMENT DIVISION
NOIDA, INDIA

	TECHNICAL SPECIFICATION & DATA SHEET FOR CONTROL VALVE WITH ACCESSORIES (PNEUMATICALLY OPERATED)	Specification No.: PE-TS-497-145-H104
		Rev. No. 00
		Date : 04.10.23

INDEX

Sl No.	DESCRIPTION	PAGE NO.
1	SCOPE	3
2	SPECIFIC TECHNICAL REQUIREMENTS	4
3	DATA SHEET	29
4	QUALITY PLAN	30
5	DATA SHEET FOR CONTROL VALVE ACCESSORIES	37
6	BILL OF QUANTITY (BOQ)	38
7	BILL OF QUANTITY (BOQ)-MANDATORY SPARES	39
8	SPECIFICATION FOR SMART POSITIONER	40
9	CONTROL VALVE HOOK UP DIAGRAM	41
10	PAINTING & PACKING	44
11	COMPLIANCE CERTIFICATE	46
12	DOCUMENT REQUIRED	47
13	DATASHEET TO BE FILLED BY BIDDER	48

	TECHNICAL SPECIFICATION & DATA SHEET FOR CONTROL VALVE WITH ACCESSORIES (PNEUMATICALLY OPERATED)	Specification No.: PE-TS-497-145-H104
		Rev. No. 00
		Date : 04.10.23

SCOPE

CONTROL VALVES COMPLETE WITH POSITIONER AND ALL ACCESSORIES MOUNTED, TUBED AND TERMINATED ON JB:		
1	SUPPLY INCLUDING DESIGN, ENGINEERING & MANUFACTURING	YES
2	INSPECTION & TESTING INCLUDING CV TEST	YES
3	ERECTION & COMMISSIONING	NO
4	SUPERVISION OF ERECTION & COMMISSIONING	NO
5	COMMISSIONING SPARES	YES
6	MANDATORY SPARES	YES
7	O & M SPARES	NO
8	PACKING	YES
9	PAINTING	YES
10	TRANSPORTATION & DELIVERY TO SITE	YES

	TECHNICAL SPECIFICATION & DATA SHEET FOR CONTROL VALVE WITH ACCESSORIES (PNEUMATICALLY OPERATED)	Specification No.: PE-TS-999-145-H104
		Rev. No. 00
		Date : 04.10.23
SPECIFIC NOTES- TO BE FOLLOWED FOR ALL THE CONTROL VALVES		
1	The control valves shall be designed as per the latest version of the following codes/Standards :-	
1.1	Control Valve Sizing :	ISA S-75
1.2	Pressure / Temperature Rating :	ANSI-B16.34
1.3	Seat Leakage :	ANSI/FCI 70.2
1.4	Noise :	IEC 60534-4
1.5	End Connection: Butt Weld	ANSI B16.25;
1.6	End Connection: Socket Weld	ANSI B16.11
1.7	End Connection: Flanged End	ANSI B16.5
1.8	End To End Tolerance :	ANSI B16.10
2	The Control valve, Actuator and the accessories operating conditions	Continuous operation under an ambient temperature : 0-60°C, Relative Humidity : 0-95%.
3	Valve Selection Criteria :	
3.1	Valve Opening at maximum flow conditions	not greater than 80% of total Valve stem travel
3.2	Valve Opening at minimum flow conditions	not less than 10% of total Valve stem travel
3.3	Stem travel from minimum flow to maximum flow	not less than 50% of total Valve stem travel
3.3	Flow capability	120% of maximum flow
4	Trim requirement for cavitation / flashing service	Anticavitation Trim/ Hardened Trim
5.1	Bonnet joints type	Flanged and Bolt
5.2	Type of Bonnet when fluid temperature is greater than 280 deg. C	Extended Bonnets
6.1	Plug Type	Plug shall be of one-piece construction cast, forged or machined from solid bar stock, BALANCED type
6.2	Plug connection with stem	Plug shall be screwed and pinned to valve stems or shall be integral with the valve stems.
7	Control Valve Guide type	High lift cage guided plugs
8	Trim type	Quick-change
9	Noise abatement method	The noise abatement shall be achieved by valve body and trim design and not by use of silencers except for few cases as per contractor's standard and proven practice subject to employer's approval.
10.1	Scope of Expander/Reducer between valve body and pipe	BHEL
10.2	Scope of Expander/Reducer between valve body diffuser, cartridge, silencer	Bidder
11	Flow action for vacuum application	Above the Seat
12	Painting Details	Refer Specification
13	Packing Details	Refer Specification
14	Valve actuators and stems shall be adequate to handle the unbalanced forces occurring under the specified flow conditions or the maximum differential pressure specified. An adequate allowance for stem force, at least 0.15 Kg/sq.cm. per linear millimeter of seating surface, shall be	

	TECHNICAL SPECIFICATION & DATA SHEET FOR CONTROL VALVE WITH ACCESSORIES (PNEUMATICALLY OPERATED)		Specification No.: PE-TS-497-145-H104			
			Rev. No. 00			
			Date :04.10.23			
SPECIFICATION & DATA SHEET FOR CONTROL VALVE						
A. GENERAL INFORMATION						
1	TAG NUMBER / SERVICE		ASV-8		D/A PEGGING FROM AUX. STEAM HEADER	
2	LOCATION / DUTY		INDOOR		MODULATING	
B. DESIGN CODES & STANDARDS						
3	CODE / STANDARD		REFER SPECIFIC NOTES			
C. TECHNICAL PARAMETERS / DESIGN FEATURES						
4	PIPE SIZE (OD X THK) mm		INLET	219.1 x 6.35	OUTLET	457 x 9.53
5	PIPE MATERIAL INLET / OUTLET		SA 106 GR B		SA 106 GR B	
6	VALVE BODY TYPE / MATERIAL / MINIMUM SIZE OF VALVE		GLOBE	A217WC6	8"	
7	GUIDING / NO. OF PORTS / TRIM FORM		CAGE	ONE	LINEAR	
8	CAGE TYPE / CAGE MATERIAL / GUIDE BUSH Material		LO-DB	SS 316 STELLITED	SS 316 STELLITED	
9	MATERIAL: PLUG / STEM / SEAT / YOKE		SS 316 STELLITED	SS 316 STELLITED	SS 316 STELLITED	CARBON STEEL
10	PACKING MATERIAL / NOS / TYPE		GRAFOIL	SINGLE	STANDARD	
11	END CONNECTION / ANSI RATING / BONNET TYPE		BWE	300	EXTENDED	
12	VALVE OUTLET VELOCITY		< 150 M/SEC(STEAM)			
13	LEAKAGE CLASS / NOISE LEVEL (dBA)		IV		< 85 dBA	
14	VACUUM SERVICE / ANTI CAVITATION TRIM		NO		NO	
15	ACTUATOR TYPE		PNEUMATIC WITH SMART POSITIONER (PROFIBUS)			
16	TRAVEL TIME FOR OPEN TO CLOSE, CLOSE TO OPEN		LESS THAN 10 SEC			
17	VALVE POSN. ON: ELECTRICAL SIGNAL FAILURE / SUPPLY AIR FAILURE		TO OPEN		STAYPUT	
18	SMART POSITIONER / POSITION LIMIT SWITCH		REQUIRED		REQUIRED	
19	POSITION TRANSMITTER / E/P CONVERTER		PART OF SMART POSITIONER		PART OF SMART POSITIONER	
20	AIR FILTER REGULATOR / AIR LOCK RELAY		REQUIRED		REQUIRED	
21	SOLENOID VALVE / JUNCTION BOX		NOT REQUIRED		REQUIRED	
22	HAND WHEEL (SIDE MOUNTED) / LOCAL POSITIONER INDICATOR		REQUIRED		REQUIRED	
23	SERVICE CONDITIONS		FLOW (T/HR)	INLET PR KG/CM2(A)	OUTLET PR. KG/CM2(A)	TEMP DEG. C
24	CASE-1	7.5 % BMCR	15.5	16	1.65	310
25	CASE-2	15 % BMCR(COLD)	31	16	1.65	310
26	CASE-3	15 % BMCR(HOT)	43.18	16	3.65	310
27	CASE-4	25 % BMCR(COLD)	51.53	16	1.65	310
28	CASE-5	40% COLD (CHECK CASE)	82.5	16	1.65	310
29	MAX SHUT OFF PRESSURE,BODY DESIGN PRESSURE (KG/CM2 (g)),TEMP (DEG C)			20	20	350
30	IBR FORM-III C		REQUIRED			
31	PROCESS CONDITION		HIGH DP			
D. GUARENTEED PERFORMANCE REQUIREMENTS						
32	LINEARITY / HYSTERISIS / SENSITIVITY / OVERALL ACCURACY		+/- 1%	+/- 1%	+/- 0.5%	+/- 2%
33	MODEL OF CONTROL VALVE		BIDDER TO FURNISH			
34	SIZE OF CONTROL VALVE		BIDDER TO FURNISH			

	TECHNICAL SPECIFICATION & DATA SHEET FOR CONTROL VALVE WITH ACCESSORIES (PNEUMATICALLY OPERATED)		Specification No.: PE-TS-497-145-H104			
			Rev. No. 00			
			Date :04.10.23			
SPECIFICATION & DATA SHEET FOR CONTROL VALVE						
A. GENERAL INFORMATION						
1	TAG NUMBER / SERVICE		CDV-25		LOW LOAD CONDENSATE CONTROL	
2	LOCATION / DUTY		INDOOR		MODULATING	
B. DESIGN CODES & STANDARDS						
3	CODE / STANDARD		REFER SPECIFIC NOTES			
C. TECHNICAL PARAMETERS / DESIGN FEATURES						
4	PIPE SIZE (OD X THK) mm		INLET	273 x 9.27	OUTLET	273 x 9.27
5	PIPE MATERIAL INLET / OUTLET		SA 106 GR B		SA 106 GR B	
6	VALVE BODY TYPE / MATERIAL / MINIMUM SIZE OF VALVE		GLOBE	A216WCB	10"	
7	GUIDING / NO. OF PORTS / TRIM FORM		CAGE	ONE	EQ %	
8	CAGE TYPE / CAGE MATERIAL / GUIDE BUSH Material		STANDARD	SS 316 STELLITED	SS 316 STELLITED	
9	MATERIAL: PLUG / STEM / SEAT / YOKE		SS 316 STELLITED	SS 316 STELLITED	SS 316 STELLITED	CARBON STEEL
10	PACKING MATERIAL / NOS / TYPE		GRAFOIL	SINGLE	STANDARD	
11	END CONNECTION / ANSI RATING / BONNET TYPE		BWE	300	STANDARD	
12	VALVE OUTLET VELOCITY		< 7 M/SEC(WATER)			
13	LEAKAGE CLASS / NOISE LEVEL (dBA)		IV		< 85 dBA	
14	VACUUM SERVICE / ANTI CAVITATION TRIM		NO		NO	
15	ACTUATOR TYPE		PNEUMATIC WITH SMART POSITIONER (HART)			
16	TRAVEL TIME FOR OPEN TO CLOSE, CLOSE TO OPEN		LESS THAN 10 SEC			
17	VALVE POSN. ON: ELECTRICAL SIGNAL FAILURE / SUPPLY AIR FAILURE		TO CLOSE		STAYPUT	
18	SMART POSITIONER / POSITION LIMIT SWITCH		REQUIRED		REQUIRED	
19	POSITION TRANSMITTER / E/P CONVERTER		PART OF SMART POSITIONER		PART OF SMART POSITIONER	
20	AIR FILTER REGULATOR / AIR LOCK RELAY		REQUIRED		REQUIRED	
21	SOLENOID VALVE / JUNCTION BOX		NOT REQUIRED		REQUIRED	
22	HAND WHEEL (SIDE MOUNTED) / LOCAL POSITIONER INDICATOR		REQUIRED		REQUIRED	
23	SERVICE CONDITIONS		FLOW (T/HR)	INLET PR KG/CM2(A)	OUTLET PR. KG/CM2(A)	TEMP DEG. C
24	CASE-1	Min. (10% TMCR flow)	127	20	4.9	48.7
25	CASE-2	30% TMCR	483.341	20	9.1	48.7
26	CASE-3	40% TMCR	575.39	20	10.9	48.3
27	CASE-4	50% TMCR	668.54	20	12.6	47.9
28	CASE-5	60% TMCR	74.85	20	14.5	47.7
29	CASE-6	65% TMCR	855.603	20	15	47.5
30	CASE-7	80% TMCR (CHECK CASE)	1024.264	20	18	47.3
31	MAX SHUT OFF PRESSURE,BODY DESIGN PRESSURE (KG/CM2 (g)), TEMP (DEG C)			50	50	55
32	IBR FORM-IIIC		NOT REQUIRED			
33	PROCESS CONDITION					
D. GUARENTEED PERFORMANCE REQUIREMENTS						
34	LINEARITY / HYSTERISIS / SENSITIVITY / OVERALL ACCURACY		+/- 1%	+/- 1%	+/- 0.5%	+/- 2%
35	MODEL OF CONTROL VALVE		BIDDER TO FURNISH			
36	SIZE OF CONTROL VALVE		BIDDER TO FURNISH			

	TECHNICAL SPECIFICATION & DATA SHEET FOR CONTROL VALVE WITH ACCESSORIES (PNEUMATICALLY OPERATED)		Specification No.: PE-TS-497-145-H104			
			Rev. No. 00			
			Date :04.10.23			
SPECIFICATION & DATA SHEET FOR CONTROL VALVE						
A. GENERAL INFORMATION						
1	TAG NUMBER / SERVICE	CDV-39		GSC/CEP MIN. FLOW RECIRCULATION		
2	LOCATION / DUTY	INDOOR		MODULATING		
B. DESIGN CODES & STANDARDS						
3	CODE / STANDARD	REFER SPECIFIC NOTES				
C. TECHNICAL PARAMETERS / DESIGN FEATURES						
4	PIPE SIZE (OD X THK) mm	INLET	168.3 x 7.11	OUTLET	168.3 x 7.11	
5	PIPE MATERIAL INLET / OUTLET	SA 106 GR B			SA 106 GR B	
6	VALVE BODY TYPE / MATERIAL / MINIMUM SIZE OF VALVE	GLOBE	A217WC9	6"		
7	GUIDING / NO. OF PORTS / TRIM FORM	CAGE	ONE	EQ %		
8	CAGE TYPE / CAGE MATERIAL / GUIDE BUSH Material	ANTI-CAVITATION	17-4 PH SS	17-4 PH SS		
9	MATERIAL: PLUG / STEM / SEAT / YOKE	17-4 PH SS	17-4 PH SS	17-4 PH SS	CARBON STEEL	
10	PACKING MATERIAL / NOS / TYPE	GRAFOIL	DOUBLE	V-CHEVRON		
11	END CONNECTION / ANSI RATING / BONNET TYPE	BWE	300	STANDARD		
12	VALVE OUTLET VELOCITY	< 7 M/SEC(WATER)				
13	LEAKAGE CLASS / NOISE LEVEL (dBA)	V			< 85 dBA	
14	VACUUM SERVICE / ANTI CAVITATION TRIM	YES			YES	
15	ACTUATOR TYPE	PNEUMATIC WITH SMART POSITIONER (PROFIBUS)				
16	TRAVEL TIME FOR OPEN TO CLOSE, CLOSE TO OPEN	LESS THAN 10 SEC				
17	VALVE POSN. ON: ELECTRICAL SIGNAL FAILURE / SUPPLY AIR FAILURE	TO OPEN			STAYPUT	
18	SMART POSITIONER / POSITION LIMIT SWITCH	REQUIRED			REQUIRED	
19	POSITION TRANSMITTER / E/P CONVERTER	PART OF SMART POSITIONER			PART OF SMART POSITIONER	
20	AIR FILTER REGULATOR / AIR LOCK RELAY	REQUIRED			REQUIRED	
21	SOLENOID VALVE / JUNCTION BOX	NOT REQUIRED			REQUIRED	
22	HAND WHEEL (SIDE MOUNTED) / LOCAL POSITIONER INDICATOR	REQUIRED			REQUIRED	
23	SERVICE CONDITIONS (LOAD)	FLOW (T/HR)	INLET PR KG/CM2(A)	OUTLET PR. KG/CM2(A)	TEMP DEG. C	
24	GSC Min Flow R/C	32.4	20	0.02	47.3	
25	Min R/C at Max. speed	324	45.8	0.02	47.3	
26	Min R/C at Min. speed	324	20	0.02	47.3	
27						
28	MAX SHUT OFF PRESSURE,BODY DESIGN PRESSURE (KG/CM2 (g)), TEMP (DEG C)		50	50/VACCUM	55	
29	IBR FORM-III C	NOT REQUIRED				
30	PROCESS CONDITION	HIGH DP,CAVITATION				
D. GUARENTEED PERFORMANCE REQUIREMENTS						
31	LINEARITY / HYSTERISIS / SENSITIVITY / OVERALL ACCURACY	+/- 1%	+/- 1%	+/- 0.5%	+/- 2%	
32	MODEL OF CONTROL VALVE	BIDDER TO FURNISH				
33	SIZE OF CONTROL VALVE	BIDDER TO FURNISH				

	TECHNICAL SPECIFICATION & DATA SHEET FOR CONTROL VALVE WITH ACCESSORIES (PNEUMATICALLY OPERATED)	Specification No.: PE-TS-497-145-H104			
		Rev. No. 00			
		Date :04.10.23			
SPECIFICATION & DATA SHEET FOR CONTROL VALVE					
A. GENERAL INFORMATION					
1	TAG NUMBER / SERVICE	CDV-43		EXCESS RETURN TO CST	
2	LOCATION / DUTY	INDOOR		MODULATING	
B. DESIGN CODES & STANDARDS					
3	CODE / STANDARD	REFER SPECIFIC NOTES			
C. TECHNICAL PARAMETERS / DESIGN FEATURES					
4	PIPE SIZE (OD X THK) mm	INLET	219.1 x 8.18	OUTLET	219.1 x 6.35
5	PIPE MATERIAL INLET / OUTLET	SA 106 GR C		SA 106 GR C	
6	VALVE BODY TYPE / MATERIAL / MINIMUM SIZE OF VALVE	GLOBE	A216WCB	6"	
7	GUIDING / NO. OF PORTS / TRIM FORM	CAGE	ONE	EQ %	
8	CAGE TYPE / CAGE MATERIAL / GUIDE BUSH Material	STANDARD	SS 316 STELLITED	SS 316 STELLITED	
9	MATERIAL: PLUG / STEM / SEAT / YOKE	SS 316 STELLITED	SS 316 STELLITED	SS 316 STELLITED	CARBON STEEL
10	PACKING MATERIAL / NOS / TYPE	GRAFOIL	SINGLE	STANDARD	
11	END CONNECTION / ANSI RATING / BONNET TYPE	BWE	300	STANDARD	
12	VALVE OUTLET VELOCITY	< 7 M/SEC(WATER)			
13	LEAKAGE CLASS / NOISE LEVEL (dBA)	V		< 85 dBA	
14	VACUUM SERVICE / ANTI CAVITATION TRIM	NO		NO	
15	ACTUATOR TYPE	PNEUMATIC WITH SMART POSITIONER (PROFIBUS)			
16	TRAVEL TIME FOR OPEN TO CLOSE, CLOSE TO OPEN	LESS THAN 10 SEC			
17	VALVE POSN. ON: ELECTRICAL SIGNAL FAILURE / SUPPLY AIR FAILURE	TO OPEN		STAYPUT	
18	SMART POSITIONER / POSITION LIMIT SWITCH	REQUIRED		REQUIRED	
19	POSITION TRANSMITTER / E/P CONVERTER	PART OF SMART POSITIONER		PART OF SMART POSITIONER	
20	AIR FILTER REGULATOR / AIR LOCK RELAY	REQUIRED		REQUIRED	
21	SOLENOID VALVE / JUNCTION BOX	NOT REQUIRED		REQUIRED	
22	HAND WHEEL (SIDE MOUNTED) / LOCAL POSITIONER INDICATOR	REQUIRED		REQUIRED	
23	SERVICE CONDITIONS (LOAD)	FLOW (T/HR)	INLET PR. KG/CM2(A)	OUTLET PR. KG/CM2(A)	TEMP DEG. C
24	Min Excess Condensate Return	34	20	1.8	47.3
25	Min Recir at Min. speed	336	20	1.79	47.3
26	Min Recir at Max. speed	336	47	1.8	47.3
27	Check case	750	20	1.79	47.3
28	MAX SHUT OFF PRESSURE, BODY DESIGN PRESSURE (KG/CM2 (g)), TEMP (DEG C)		50	50	55
29	IBR FORM-IIIIC	NOT REQUIRED			
30	PROCESS CONDITION	HIGH DP			
D. GUARENTEED PERFORMANCE REQUIREMENTS					
31	LINEARITY / HYSTERISIS / SENSITIVITY / OVERALL ACCURACY	+/- 1%	+/- 1%	+/- 0.5%	+/- 2%
32	MODEL OF CONTROL VALVE	BIDDER TO FURNISH			
33	SIZE OF CONTROL VALVE	BIDDER TO FURNISH			

	TECHNICAL SPECIFICATION & DATA SHEET FOR CONTROL VALVE WITH ACCESSORIES (PNEUMATICALLY OPERATED)	Specification No.: PE-TS-497-145-H104			
		Rev. No. 00			
		Date :04.10.23			
SPECIFICATION & DATA SHEET FOR CONTROL VALVE					
A. GENERAL INFORMATION					
1	TAG NUMBER / SERVICE	CDV-65,CDV-67,CDV-69		CEP MIN. FLOW RECIRCULATION	
2	LOCATION / DUTY	INDOOR		MODULATING	
B. DESIGN CODES & STANDARDS					
3	CODE / STANDARD	REFER SPECIFIC NOTES			
C. TECHNICAL PARAMETERS / DESIGN FEATURES					
4	PIPE SIZE (OD X THK) mm	INLET	168.3 x 7.11	OUTLET	168.3 x 7.11
5	PIPE MATERIAL INLET / OUTLET	SA 106 GR B		SA 106 GR B	
6	VALVE BODY TYPE / MATERIAL / MINIMUM SIZE OF VALVE	GLOBE	A217WC9	6"	
7	GUIDING / NO. OF PORTS / TRIM FORM	CAGE	ONE	EQ %	
8	CAGE TYPE / CAGE MATERIAL / GUIDE BUSH Material	ANTI-CAVITATION	17-4 PH SS	17-4 PH SS	
9	MATERIAL: PLUG / STEM / SEAT / YOKE	17-4 PH SS	17-4 PH SS	17-4 PH SS	CARBON STEEL
10	PACKING MATERIAL / NOS / TYPE	GRAFOIL	DOUBLE	V-CHEVRON	
11	END CONNECTION / ANSI RATING / BONNET TYPE	BWE	300	STANDARD	
12	VALVE OUTLET VELOCITY	< 7 M/SEC(WATER)			
13	LEAKAGE CLASS / NOISE LEVEL (dBA)	V		< 85 dBA	
14	VACUUM SERVICE / ANTI CAVITATION TRIM	YES		YES	
15	ACTUATOR TYPE	PNEUMATIC WITH SMART POSITIONER (HART)			
16	TRAVEL TIME FOR OPEN TO CLOSE, CLOSE TO OPEN	LESS THAN 10 SEC			
17	VALVE POSN. ON: ELECTRICAL SIGNAL FAILURE / SUPPLY AIR FAILURE	TO OPEN		STAYPUT	
18	SMART POSITIONER / POSITION LIMIT SWITCH	REQUIRED		REQUIRED	
19	POSITION TRANSMITTER / E/P CONVERTER	PART OF SMART POSITIONER		PART OF SMART POSITIONER	
20	AIR FILTER REGULATOR / AIR LOCK RELAY	REQUIRED		REQUIRED	
21	SOLENOID VALVE / JUNCTION BOX	REQUIRED		REQUIRED	
22	HAND WHEEL (SIDE MOUNTED) / LOCAL POSITIONER INDICATOR	REQUIRED		REQUIRED	
23	SERVICE CONDITIONS (LOAD)	FLOW (T/HR)	INLET PR KG/CM2(A)	OUTLET PR. KG/CM2(A)	TEMP DEG. C
24	CEP Min flow R/C	30	21	0.04	47.3
25	Min Recir at Min. speed	168.2	21	0.04	47.3
26	Min Recir at Max. speed	247.4	47	0.04	47.3
27					
28	MAX SHUT OFF PRESSURE,BODY DESIGN PRESSURE (KG/CM2 (g)), TEMP (DEG C)		50	50/VACCUM	55
29	IBR FORM-IIIC	NOT REQUIRED			
30	PROCESS CONDITION	HIGH DP,CAVITATION			
D. GUARENTEED PERFORMANCE REQUIREMENTS					
31	LINEARITY / HYSTERISIS / SENSITIVITY / OVERALL ACCURACY	+/- 1%	+/- 1%	+/- 0.5%	+/- 2%
32	MODEL OF CONTROL VALVE	BIDDER TO FURNISH			
33	SIZE OF CONTROL VALVE	BIDDER TO FURNISH			

	TECHNICAL SPECIFICATION & DATA SHEET FOR CONTROL VALVE WITH ACCESSORIES (PNEUMATICALLY OPERATED)	Specification No.: PE-TS-497-145-H104			
		Rev. No. 00			
		Date :04.10.23			
SPECIFICATION & DATA SHEET FOR CONTROL VALVE					
A. GENERAL INFORMATION					
1	TAG NUMBER / SERVICE	CDV-72		CONDENSATE FOR VALVE GLAND SEALING	
2	LOCATION / DUTY	INDOOR		MODULATING	
B. DESIGN CODES & STANDARDS					
3	CODE / STANDARD	REFER SPECIFIC NOTES			
C. TECHNICAL PARAMETERS / DESIGN FEATURES					
4	PIPE SIZE (OD X THK) mm	INLET	60.3 x 5.54	OUTLET	60.3 x 5.54
5	PIPE MATERIAL INLET / OUTLET	SA 106 GR B		SA 106 GR B	
6	VALVE BODY TYPE / MATERIAL / MINIMUM SIZE OF VALVE	GLOBE	A216WCB	1"	
7	GUIDING / NO. OF PORTS / TRIM FORM	CAGE	ONE	EQ %	
8	CAGE TYPE / CAGE MATERIAL / GUIDE BUSH Material	STANDARD	SS 316 STELLITED	SS 316 STELLITED	
9	MATERIAL: PLUG / STEM / SEAT / YOKE	SS 316 STELLITED	SS 316 STELLITED	SS 316 STELLITED	CARBON STEEL
10	PACKING MATERIAL / NOS / TYPE	GRAFOIL	SINGLE	STANDARD	
11	END CONNECTION / ANSI RATING / BONNET TYPE	BWE	300	STANDARD	
12	FLOW ACTION / VALVE OUTLET VELOCITY	< 7 M/SEC(WATER)			
13	LEAKAGE CLASS / NOISE LEVEL (dBA)	V		< 85 dBA	
14	VACUUM SERVICE / ANTI CAVITATION TRIM	NO		NO	
15	ACTUATOR TYPE	PNEUMATIC WITH SMART POSITIONER (PROFIBUS)			
16	TRAVEL TIME FOR OPEN TO CLOSE, CLOSE TO OPEN	LESS THAN 10 SEC			
17	VALVE POSN. ON: ELECTRICAL SIGNAL FAILURE / SUPPLY AIR FAILURE	TO OPEN		STAYPUT	
18	SMART POSITIONER / POSITION LIMIT SWITCH	REQUIRED		REQUIRED	
19	POSITION TRANSMITTER / E/P CONVERTER	PART OF SMART POSITIONER		PART OF SMART POSITIONER	
20	AIR FILTER REGULATOR / AIR LOCK RELAY	REQUIRED		REQUIRED	
21	SOLENOID VALVE / JUNCTION BOX	NOT REQUIRED		REQUIRED	
22	HAND WHEEL (SIDE MOUNTED) / LOCAL POSITIONER INDICATOR	REQUIRED		REQUIRED	
23	SERVICE CONDITIONS (LOAD)	FLOW (T/HR)	INLET PR KG/CM2(A)	OUTLET PR. KG/CM2(A)	TEMP DEG. C
24	Min Condensate to Valve GS	4	20	0.2	47.3
25	MIN.	10	20	2.61	47.3
26	MAX.	10	46.2	2.61	47.3
27					
28	MAX SHUT OFF PRESSURE,BODY DESIGN PRESSURE (KG/CM2 (g)), TEMP (DEG C)		50	50	55
29	IBR FORM-III C	NOT REQUIRED			
30	PROCESS CONDITION				
D. GUARENTEED PERFORMANCE REQUIREMENTS					
31	LINEARITY / HYSTERISIS / SENSITIVITY / OVERALL ACCURACY	+/- 1%	+/- 1%	+/- 0.5%	+/- 2%
32	MODEL OF CONTROL VALVE	BIDDER TO FURNISH			
33	SIZE OF CONTROL VALVE	BIDDER TO FURNISH			

	TECHNICAL SPECIFICATION & DATA SHEET FOR CONTROL VALVE WITH ACCESSORIES (PNEUMATICALLY OPERATED)	Specification No.: PE-TS-497-145-H104			
		Rev. No. 00			
		Date :04.10.23			
SPECIFICATION & DATA SHEET FOR CONTROL VALVE					
A. GENERAL INFORMATION					
1	TAG NUMBER / SERVICE	CDV-84		CONDENSATE FOR FLASH TANK-B SPRAY	
2	LOCATION / DUTY	INDOOR		MODULATING	
B. DESIGN CODES & STANDARDS					
3	CODE / STANDARD	REFER SPECIFIC NOTES			
C. TECHNICAL PARAMETERS / DESIGN FEATURES					
4	PIPE SIZE (OD X THK) mm	INLET	33.4 x 4.55	OUTLET	33.4 x 4.55
5	PIPE MATERIAL INLET / OUTLET	SA 106 GR B		SA 106 GR B	
6	VALVE BODY TYPE / MATERIAL / MINIMUM SIZE OF VALVE	GLOBE	A217WC9	1"	
7	GUIDING / NO. OF PORTS / TRIM FORM	CAGE	ONE	EQ %	
8	CAGE TYPE / CAGE MATERIAL / GUIDE BUSH Material	ANTI-CAVITATION	440C	440C	
9	MATERIAL: PLUG / STEM / SEAT / YOKE	440C	440C	440C	CARBON STEEL
10	PACKING MATERIAL / NOS / TYPE	GRAFOIL	DOUBLE	V-CHEVRON	
11	END CONNECTION / ANSI RATING / BONNET TYPE	BWE	300	STANDARD	
12	FLOW ACTION / VALVE OUTLET VELOCITY	< 7 M/SEC(WATER)			
13	LEAKAGE CLASS / NOISE LEVEL (dBA)	V		< 85 dBA	
14	VACUUM SERVICE / ANTI CAVITATION TRIM	YES		YES	
15	ACTUATOR TYPE	PNEUMATIC WITH SMART POSITIONER (PROFIBUS)			
16	TRAVEL TIME FOR OPEN TO CLOSE, CLOSE TO OPEN	LESS THAN 10 SEC			
17	VALVE POSN. ON: ELECTRICAL SIGNAL FAILURE / SUPPLY AIR FAILURE	TO OPEN		STAYPUT	
18	SMART POSITIONER / POSITION LIMIT SWITCH	REQUIRED		REQUIRED	
19	POSITION TRANSMITTER / E/P CONVERTER	PART OF SMART POSITIONER		PART OF SMART POSITIONER	
20	AIR FILTER REGULATOR / AIR LOCK RELAY	REQUIRED		REQUIRED	
21	SOLENOID VALVE / JUNCTION BOX	NOT REQUIRED		REQUIRED	
22	HAND WHEEL (SIDE MOUNTED) / LOCAL POSITIONER INDICATOR	REQUIRED		REQUIRED	
23	SERVICE CONDITIONS (LOAD)	FLOW (T/HR)	INLET PR KG/CM2(A)	OUTLET PR. KG/CM2(A)	TEMP DEG. C
24	MIN. Condensate to FT-B Spray	4	20	0.2	47.3
25	MIN. SPEED	10	20	0.2	47.3
26	MAX. SPEED	10	46.5	0.2	47.3
27					
28	MAX SHUT OFF PRESSURE,BODY DESIGN PRESSURE (KG/CM2 (g)), TEMP (DEG C)		50	50	55
29	IBR FORM-IIC	NOT REQUIRED			
30	PROCESS CONDITION	CAVITATION, HIGH DP			
D. GUARENTEED PERFORMANCE REQUIREMENTS					
31	LINEARITY / HYSTERISIS / SENSITIVITY / OVERALL ACCURACY	+/- 1%	+/- 1%	+/- 0.5%	+/- 2%
32	MODEL OF CONTROL VALVE	BIDDER TO FURNISH			
33	SIZE OF CONTROL VALVE	BIDDER TO FURNISH			

	TECHNICAL SPECIFICATION & DATA SHEET FOR CONTROL VALVE WITH ACCESSORIES (PNEUMATICALLY OPERATED)	Specification No.: PE-TS-497-145-H104			
		Rev. No. 00			
		Date :04.10.23			
SPECIFICATION & DATA SHEET FOR CONTROL VALVE					
A. GENERAL INFORMATION					
1	TAG NUMBER / SERVICE	CDV-94		CONDENSATE FOR UNIT FLASH TANK SPRAY	
2	LOCATION / DUTY	INDOOR		MODULATING	
B. DESIGN CODES & STANDARDS					
3	CODE / STANDARD	REFER SPECIFIC NOTES			
C. TECHNICAL PARAMETERS / DESIGN FEATURES					
4	PIPE SIZE (OD X THK) mm	INLET	33.4 x 4.55	OUTLET	33.4 x 4.55
5	PIPE MATERIAL INLET / OUTLET	SA 106 GR B		SA 106 GR B	
6	VALVE BODY TYPE / MATERIAL / MINIMUM SIZE OF VALVE	GLOBE	A217WC9	1"	
7	GUIDING / NO. OF PORTS / TRIM FORM	CAGE	ONE	EQ %	
8	CAGE TYPE / CAGE MATERIAL / GUIDE BUSH Material	ANTI-CAVITATION	440C	440C	
9	MATERIAL: PLUG / STEM / SEAT / YOKE	440C	440C	440C	CARBON STEEL
10	PACKING MATERIAL / NOS / TYPE	GRAFOIL	DOUBLE	V-CHEVRON	
11	END CONNECTION / ANSI RATING / BONNET TYPE	BWE	300	STANDARD	
12	FLOW ACTION / VALVE OUTLET VELOCITY	< 7 M/SEC(WATER)			
13	LEAKAGE CLASS / NOISE LEVEL (dBA)	V		< 85 dBA	
14	VACUUM SERVICE / ANTI CAVITATION TRIM	YES		YES	
15	ACTUATOR TYPE	PNEUMATIC WITH SMART POSITIONER (PROFIBUS)			
16	TRAVEL TIME FOR OPEN TO CLOSE, CLOSE TO OPEN	LESS THAN 10 SEC			
17	VALVE POSN. ON: ELECTRICAL SIGNAL FAILURE / SUPPLY AIR FAILURE	TO OPEN		STAYPUT	
18	SMART POSITIONER / POSITION LIMIT SWITCH	REQUIRED		REQUIRED	
19	POSITION TRANSMITTER / E/P CONVERTER	PART OF SMART POSITIONER		PART OF SMART POSITIONER	
20	AIR FILTER REGULATOR / AIR LOCK RELAY	REQUIRED		REQUIRED	
21	SOLENOID VALVE / JUNCTION BOX	NOT REQUIRED		REQUIRED	
22	HAND WHEEL (SIDE MOUNTED) / LOCAL POSITIONER INDICATOR	REQUIRED		REQUIRED	
23	SERVICE CONDITIONS (LOAD)	FLOW (T/HR)	INLET PR. KG/CM2(A)	OUTLET PR. KG/CM2(A)	TEMP DEG. C
24	MIN.	4	3	1	33
25	MAX.	10	3	1	33
26					
27					
28	MAX SHUT OFF PRESSURE, BODY DESIGN PRESSURE (KG/CM2 (g)), TEMP (DEG C)	50		50	60
29	IBR FORM-IIIC	NOT REQUIRED			
30	PROCESS CONDITION	HIGH DP			
D. GUARENTEED PERFORMANCE REQUIREMENTS					
31	LINEARITY / HYSTERISIS / SENSITIVITY / OVERALL ACCURACY	+/- 1%	+/- 1%	+/- 0.5%	+/- 2%
32	MODEL OF CONTROL VALVE	BIDDER TO FURNISH			
33	SIZE OF CONTROL VALVE	BIDDER TO FURNISH			

	TECHNICAL SPECIFICATION & DATA SHEET FOR CONTROL VALVE WITH ACCESSORIES (PNEUMATICALLY OPERATED)		Specification No.: PE-TS-497-145-H104			
			Rev. No. 00			
			Date :04.10.23			
SPECIFICATION & DATA SHEET FOR CONTROL VALVE						
A. GENERAL INFORMATION						
1	TAG NUMBER / SERVICE		CRHV-6		D/A PEGGING FROM CRH LINE	
2	LOCATION / DUTY		INDOOR		MODULATING	
B. DESIGN CODES & STANDARDS						
3	CODE / STANDARD		REFER SPECIFIC NOTES			
C. TECHNICAL PARAMETERS / DESIGN FEATURES						
4	PIPE SIZE (OD X THK) mm		INLET	355.6 x 19.05	OUTLET	965 x 40
5	PIPE MATERIAL INLET / OUTLET		SA 106 GR C		SA 106 GR C	
6	VALVE BODY TYPE / MATERIAL / MINIMUM SIZE OF VALVE		GLOBE	A217WC6	12"	
7	GUIDING / NO. OF PORTS / TRIM FORM		CAGE	ONE	LINEAR	
8	CAGE TYPE / CAGE MATERIAL / GUIDE BUSH Material		STANDARD	SS 316 STELLITED	SS 316 STELLITED	
9	MATERIAL: PLUG / STEM / SEAT / YOKE		SS 316 STELLITED	SS 316 STELLITED	SS 316 STELLITED	CARBON STEEL
10	PACKING MATERIAL / NOS / TYPE		GRAFOIL	SINGLE	STANDARD	
11	END CONNECTION / ANSI RATING / BONNET TYPE		BWE	600	EXTENDED	
12	VALVE OUTLET VELOCITY		< 150 M/SEC(STEAM)			
13	LEAKAGE CLASS / NOISE LEVEL (dBA)		IV		< 85 dBA	
14	VACUUM SERVICE / ANTI CAVITATION TRIM		NO		NO	
15	ACTUATOR TYPE		PNEUMATIC WITH SMART POSITIONER (PROFIBUS)			
16	TRAVEL TIME FOR OPEN TO CLOSE, CLOSE TO OPEN		LESS THAN 10 SEC			
17	VALVE POSN. ON: ELECTRICAL SIGNAL FAILURE / SUPPLY AIR FAILURE		TO CLOSE		STAYPUT	
18	SMART POSITIONER / POSITION LIMIT SWITCH		REQUIRED		REQUIRED	
19	POSITION TRANSMITTER / E/P CONVERTER		PART OF SMART POSITIONER		PART OF SMART POSITIONER	
20	AIR FILTER REGULATOR / AIR LOCK RELAY		REQUIRED		REQUIRED	
21	SOLENOID VALVE / JUNCTION BOX		NOT REQUIRED		REQUIRED	
22	HAND WHEEL (SIDE MOUNTED) / LOCAL POSITIONER INDICATOR		REQUIRED		REQUIRED	
23	SERVICE CONDITIONS		FLOW (T/HR)	INLET PR KG/CM2(A)	OUTLET PR. KG/CM2(A)	TEMP DEG. C
24	CASE-1	65% BYPASS	199.98	39.76	3.65	360
25	CASE-2	15 % BMCR	41.84	20	3.65	355
26	CASE-3	HOUSE LOAD	199.98	39.76	3.65	360
27	CASE-4	START UP	88.44	12	1.65	220
28	MAX SHUT OFF PRESSURE,BODY DESIGN PRESSURE (KG/CM2 (g)), TEMP (DEG C)		76.7		76.7	392
29	IBR FORM-III C		REQUIRED			
30	PROCESS CONDITION		HIGH DP			
D. GUARENTEED PERFORMANCE REQUIREMENTS						
31	LINEARITY / HYSTERISIS / SENSITIVITY / OVERALL ACCURACY		+/- 1%	+/- 1%	+/- 0.5%	+/- 2%
32	MODEL OF CONTROL VALVE		BIDDER TO FURNISH			
33	SIZE OF CONTROL VALVE		BIDDER TO FURNISH			

	TECHNICAL SPECIFICATION & DATA SHEET FOR CONTROL VALVE WITH ACCESSORIES (PNEUMATICALLY OPERATED)	Specification No.: PE-TS-497-145-H104			
		Rev. No. 00			
		Date :04.10.23			
SPECIFICATION & DATA SHEET FOR CONTROL VALVE					
A. GENERAL INFORMATION					
1	TAG NUMBER / SERVICE	DMV-43		NORMAL DM MU TO HOTWELL	
2	LOCATION / DUTY	INDOOR		MODULATING	
B. DESIGN CODES & STANDARDS					
3	CODE / STANDARD	REFER SPECIFIC NOTES			
C. TECHNICAL PARAMETERS / DESIGN FEATURES					
4	PIPE SIZE (OD X THK) mm INLET / OUTLET	INLET	114.3 x 3.05	OUTLET	114.3 x 3.05
5	PIPE MATERIAL INLET / OUTLET	SA 312 TP 304 (ERW)		SA 312 TP 304 (ERW)	
6	VALVE BODY TYPE / MATERIAL / MINIMUM SIZE OF VALVE	GLOBE	A351CF8M	4"	
7	GUIDING / NO. OF PORTS / TRIM FORM	CAGE	ONE	EQ %	
8	CAGE TYPE / CAGE MATERIAL / GUIDE BUSH Material	STANDARD	SS316	SS316	
9	MATERIAL: PLUG / STEM/SEAT/YOKE	SS316	SS316	SS316	CARBON STEEL
10	PACKING MATERIAL / NOS / TYPE	GRAFOIL	DOUBLE	V-CHEVRON	
11	END CONNECTION / ANSI RATING / BONNET TYPE	BWE	300	STANDARD	
12	FLOW ACTION / VALVE OUTLET VELOCITY	< 7 M/SEC(WATER)			
13	LEAKAGE CLASS / NOISE LEVEL (dBA)	V		< 85 dBA	
14	VACUUM SERVICE / ANTI CAVITATION TRIM	YES		YES	
15	ACTUATOR TYPE	PNEUMATIC WITH SMART POSITIONER (HART)			
16	TRAVEL TIME FOR OPEN TO CLOSE, CLOSE TO OPEN	LESS THAN 10 SEC			
17	VALVE POSN. ON: ELECTRICAL SIGNAL FAILURE / SUPPLY AIR FAILURE	TO OPEN		STAYPUT	
18	SMART POSITIONER / POSITION LIMIT SWITCH	REQUIRED		REQUIRED	
19	POSITION TRANSMITTER / E/P CONVERTER	PART OF SMART POSITIONER		PART OF SMART POSITIONER	
20	AIR FILTER REGULATOR / AIR LOCK RELAY	REQUIRED		REQUIRED	
21	SOLENOID VALVE / JUNCTION BOX	NOT REQUIRED		REQUIRED	
22	HAND WHEEL (SIDE MOUNTED) / LOCAL POSITIONER INDICATOR	REQUIRED		REQUIRED	
23	SERVICE CONDITIONS (LOAD)	FLOW (T/HR)	INLET PR KG/CM2(A)	OUTLET PR. KG/CM2(A)	TEMP DEG. C
24	MIN(1% MU)	20.672	8.2	0.9	33
25	NORMAL(3% MU)	62.02	6.3	1.1	33
26	MAX(5% MU)	103.36	2.5	1.6	33
27	MIN(.5% MU)	10.34	8.3	0.9	33
28					
29					
30					
31	MAX SHUT OFF PRESSURE,BODY DESIGN PRESSURE (KG/CM2 (g)), TEMP (DEG C)	12		12/VACCUM	50
32	IBR FORM-III C				
33	PROCESS CONDITION				
D. GUARENTEED PERFORMANCE REQUIREMENTS					
34	LINEARITY / HYSTERISIS / SENSITIVITY / OVERALL ACCURACY	+/- 1%	+/- 1%	+/- 0.5%	+/- 2%
35	MODEL OF CONTROL VALVE	BIDDER TO FURNISH			
36	SIZE OF CONTROL VALVE	BIDDER TO FURNISH			

	TECHNICAL SPECIFICATION & DATA SHEET FOR CONTROL VALVE WITH ACCESSORIES (PNEUMATICALLY OPERATED)	Specification No.: PE-TS-497-145-H104			
		Rev. No. 00			
		Date :04.10.23			
SPECIFICATION & DATA SHEET FOR CONTROL VALVE					
A. GENERAL INFORMATION					
1	TAG NUMBER / SERVICE	DMV-78		EMERGENCY DM MU TO HOTWELL	
2	LOCATION / DUTY	INDOOR		MODULATING	
B. DESIGN CODES & STANDARDS					
3	CODE / STANDARD	REFER SPECIFIC NOTES			
C. TECHNICAL PARAMETERS / DESIGN FEATURES					
4	PIPE SIZE (OD X THK) mm INLET / OUTLET	INLET	219.1 x 3.76	OUTLET	219.1 x 3.76
5	PIPE MATERIAL INLET / OUTLET	SA 312 TP 304 (ERW)		SA 312 TP 304 (ERW)	
6	VALVE BODY TYPE / MATERIAL / MINIMUM SIZE OF VALVE	GLOBE	A351CF8M	8"	
7	GUIDING / NO. OF PORTS / TRIM FORM	CAGE	ONE	EQ %	
8	CAGE TYPE / CAGE MATERIAL / GUIDE BUSH Material	STANDARD	SS316	SS316	
9	MATERIAL: PLUG / STEM/SEAT/YOKE	SS316	SS316	SS316	CARBON STEEL
10	PACKING MATERIAL / NOS / TYPE	GRAFOIL	DOUBLE	V-CHEVRON	
11	END CONNECTION / ANSI RATING / BONNET TYPE	BWE	300	STANDARD	
12	FLOW ACTION / VALVE OUTLET VELOCITY	< 7 M/SEC(WATER)			
13	LEAKAGE CLASS / NOISE LEVEL (dBA)	V		< 85 dBA	
14	VACUUM SERVICE / ANTI CAVITATION TRIM	YES		YES	
15	ACTUATOR TYPE	PNEUMATIC WITH SMART POSITIONER (HART)			
16	TRAVEL TIME FOR OPEN TO CLOSE, CLOSE TO OPEN	LESS THAN 10 SEC			
17	VALVE POSN. ON: ELECTRICAL SIGNAL FAILURE / SUPPLY AIR FAILURE	TO CLOSE		STAYPUT	
18	SMART POSITIONER / POSITION LIMIT SWITCH	REQUIRED		REQUIRED	
19	POSITION TRANSMITTER / E/P CONVERTER	PART OF SMART POSITIONER		PART OF SMART POSITIONER	
20	AIR FILTER REGULATOR / AIR LOCK RELAY	REQUIRED		REQUIRED	
21	SOLENOID VALVE / JUNCTION BOX	NOT REQUIRED		REQUIRED	
22	HAND WHEEL (SIDE MOUNTED) / LOCAL POSITIONER INDICATOR	REQUIRED		REQUIRED	
23	SERVICE CONDITIONS (LOAD)	FLOW (T/HR)	INLET PR KG/CM2(A)	OUTLET PR. KG/CM2(A)	TEMP DEG. C
24	MIN(5% MU)	105.5	7.6	0.9	33
25	NORMAL(10% MU)	211	6.2	0.9	33
26	MAX(15% MU)	316.5	4.6	1	33
27					
28					
29					
30					
31	MAX SHUT OFF PRESSURE,BODY DESIGN PRESSURE (KG/CM2 (g)), TEMP (DEG C)	12		12/VACCUM	50
32	IBR FORM-IIIIC				
33	PROCESS CONDITION				
D. GUARENTEED PERFORMANCE REQUIREMENTS					
34	LINEARITY / HYSTERISIS / SENSITIVITY / OVERALL ACCURACY	+/- 1%	+/- 1%	+/- 0.5%	+/- 2%
35	MODEL OF CONTROL VALVE	BIDDER TO FURNISH			
36	SIZE OF CONTROL VALVE	BIDDER TO FURNISH			

	TECHNICAL SPECIFICATION & DATA SHEET FOR CONTROL VALVE WITH ACCESSORIES (PNEUMATICALLY OPERATED)	Specification No.: PE-TS-497-145-H104			
		Rev. No. 00			
		Date :04.10.23			
SPECIFICATION & DATA SHEET FOR CONTROL VALVE					
A. GENERAL INFORMATION					
1	TAG NUMBER / SERVICE	DRV-15 & DRV-22		HPH-7A/7B NORMAL DRAIN TO DEAERATOR	
2	LOCATION / DUTY	INDOOR		MODULATING	
B. DESIGN CODES & STANDARDS					
3	CODE / STANDARD	REFER SPECIFIC NOTES			
C. TECHNICAL PARAMETERS / DESIGN FEATURES					
4	PIPE SIZE (OD X THK) mm	INLET	273 x 6.35	OUTLET	273 x 12.7
5	PIPE MATERIAL INLET / OUTLET	SA 106 GR B		SA 106 GR B	
6	VALVE BODY TYPE / MATERIAL / MINIMUM SIZE OF VALVE	GLOBE	A217WC6	6"	
7	GUIDING / NO. OF PORTS / TRIM FORM	CAGE	ONE	LINEAR	
8	CAGE TYPE / CAGE MATERIAL / GUIDE BUSH Material	STANDARD	17-4PH SS	17-4PH SS	
9	MATERIAL: PLUG / STEM/SEAT/YOKE	17-4PH SS	17-4PH SS	17-4PH SS	CARBON STEEL
10	PACKING MATERIAL / NOS / TYPE	GRAFOIL	SINGLE	STANDARD	
11	END CONNECTION / ANSI RATING / BONNET TYPE	BWE	300	STANDARD	
12	FLOW ACTION / VALVE OUTLET VELOCITY	< 7 M/SEC(WATER)			
13	LEAKAGE CLASS / NOISE LEVEL (dBA)	IV		< 85 dBA	
14	VACUUM SERVICE / ANTI CAVITATION TRIM	NO		NO	
15	ACTUATOR TYPE	PNEUMATIC WITH SMART POSITIONER (PROFIBUS)			
16	TRAVEL TIME FOR OPEN TO CLOSE, CLOSE TO OPEN	LESS THAN 10 SEC			
17	VALVE POSN. ON: ELECTRICAL SIGNAL FAILURE / SUPPLY AIR FAILURE	TO CLOSE		TO CLOSE	
18	SMART POSITIONER / POSITION LIMIT SWITCH	REQUIRED		REQUIRED	
19	POSITION TRANSMITTER / E/P CONVERTER	PART OF SMART POSITIONER		PART OF SMART POSITIONER	
20	AIR FILTER REGULATOR / AIR LOCK RELAY	REQUIRED		REQUIRED	
21	SOLENOID VALVE / JUNCTION BOX	REQUIRED		REQUIRED	
22	HAND WHEEL (SIDE MOUNTED) / LOCAL POSITIONER INDICATOR	REQUIRED		REQUIRED	
23	SERVICE CONDITIONS (LOAD)	FLOW (T/HR)	INLET PR KG/CM2(A)	OUTLET PR. KG/CM2(A)	TEMP DEG. C
24	40% LOAD	66.1	9.2	6.3	162
25	60% LOAD	105.5	13.8	8.3	175
26	100%LOAD	219.9	23.3	12.2	197.2
27	VWO	239.9	24.8	12.8	200
28	20%LOAD	38.4	3.7	4	140.6
29					
30					
31	MAX SHUT OFF PRESSURE,BODY DESIGN PRESSURE (KG/CM2 (g)), TEMP (DEG C)	32		32	205
32	IBR FORM-IIIC	NOT REQUIRED			
33	PROCESS CONDITION	FLASHING			
D. GUARENTEED PERFORMANCE REQUIREMENTS					
34	LINEARITY / HYSTERISIS / SENSITIVITY / OVERALL ACCURACY	+/- 1%	+/- 1%	+/- 0.5%	+/- 2%
35	MODEL OF CONTROL VALVE	BIDDER TO FURNISH			
36	SIZE OF CONTROL VALVE	BIDDER TO FURNISH			

	TECHNICAL SPECIFICATION & DATA SHEET FOR CONTROL VALVE WITH ACCESSORIES (PNEUMATICALLY OPERATED)	Specification No.: PE-TS-497-145-H104			
		Rev. No. 00			
		Date :04.10.23			
SPECIFICATION & DATA SHEET FOR CONTROL VALVE					
A. GENERAL INFORMATION					
1	TAG NUMBER / SERVICE	DRV-18 & DRV-25		HPH-7A/7B ALT. DRAIN TO F/T	
2	LOCATION / DUTY	INDOOR		MODULATING	
B. DESIGN CODES & STANDARDS					
3	CODE / STANDARD	REFER SPECIFIC NOTES			
C. TECHNICAL PARAMETERS / DESIGN FEATURES					
4	PIPE SIZE (OD X THK) mm	INLET	273 x 6.35	OUTLET	323.9 x 12.7
5	PIPE MATERIAL INLET / OUTLET	SA 106 GR B		SA 106 GR B	
6	VALVE BODY TYPE / MATERIAL / MINIMUM SIZE OF VALVE	GLOBE	A217WC9	6"	
7	GUIDING / NO. OF PORTS / TRIM FORM	CAGE	ONE	LINEAR	
8	CAGE TYPE / CAGE MATERIAL / GUIDE BUSH Material	STANDARD	440C	440C	
9	MATERIAL: PLUG / STEM/SEAT/YOKE	440C	440C	440C	CARBON STEEL
10	PACKING MATERIAL / NOS / TYPE	GRAFOIL	DOUBLE	V-CHEVRON	
11	END CONNECTION / ANSI RATING / BONNET TYPE	BWE	300	STANDARD	
12	FLOW ACTION / VALVE OUTLET VELOCITY	< 7 M/SEC(WATER)			
13	LEAKAGE CLASS / NOISE LEVEL (dBA)	V		< 85 dBA	
14	VACUUM SERVICE / ANTI CAVITATION TRIM	YES		NO	
15	ACTUATOR TYPE	PNEUMATIC WITH SMART POSITIONER (HART)			
16	TRAVEL TIME FOR OPEN TO CLOSE, CLOSE TO OPEN	LESS THAN 10 SEC			
17	VALVE POSN. ON: ELECTRICAL SIGNAL FAILURE / SUPPLY AIR FAILURE	TO OPEN		TO OPEN	
18	SMART POSITIONER / POSITION LIMIT SWITCH	REQUIRED		REQUIRED	
19	POSITION TRANSMITTER / E/P CONVERTER	PART OF SMART POSITIONER		PART OF SMART POSITIONER	
20	AIR FILTER REGULATOR / AIR LOCK RELAY	REQUIRED		REQUIRED	
21	SOLENOID VALVE / JUNCTION BOX	REQUIRED		REQUIRED	
22	HAND WHEEL (SIDE MOUNTED) / LOCAL POSITIONER INDICATOR	REQUIRED		REQUIRED	
23	SERVICE CONDITIONS (LOAD)	FLOW (T/HR)	INLET PR KG/CM2(A)	OUTLET PR. KG/CM2(A)	TEMP DEG. C
24	40% LOAD	66.1	11.6	0.2	184.3
25	60% LOAD	105.5	16.2	0.2	200.6
26	100%LOAD	219.9	25.9	0.2	224.6
27	VWO	239.9	27.3	0.2	227.6
28	20%LOAD	38.4	6.5	0.2	160.8
29					
30					
31	MAX SHUT OFF PRESSURE,BODY DESIGN PRESSURE (KG/CM2 (g)), TEMP (DEG C)	32		32/VACCUUM	230
32	IBR FORM-IIIC	NOT REQUIRED			
33	PROCESS CONDITION	FLASHING,HIGH DP			
D. GUARENTEED PERFORMANCE REQUIREMENTS					
34	LINEARITY / HYSTERISIS / SENSITIVITY / OVERALL ACCURACY	+/- 1%	+/- 1%	+/- 0.5%	+/- 2%
35	MODEL OF CONTROL VALVE	BIDDER TO FURNISH			
36	SIZE OF CONTROL VALVE	BIDDER TO FURNISH			

	TECHNICAL SPECIFICATION & DATA SHEET FOR CONTROL VALVE WITH ACCESSORIES (PNEUMATICALLY OPERATED)	Specification No.: PE-TS-497-145-H104			
		Rev. No. 00			
		Date :04.10.23			
SPECIFICATION & DATA SHEET FOR CONTROL VALVE					
A. GENERAL INFORMATION					
1	TAG NUMBER / SERVICE	DRV-2 & DRV-8		HPH-8A/8B NORMAL DRAIN TO HPH-7A/7B	
2	LOCATION / DUTY	INDOOR		MODULATING	
B. DESIGN CODES & STANDARDS					
3	CODE / STANDARD	REFER SPECIFIC NOTES			
C. TECHNICAL PARAMETERS / DESIGN FEATURES					
4	PIPE SIZE (OD X THK) mm	INLET	273 x 12.7	OUTLET	273 x 12.7
5	PIPE MATERIAL INLET / OUTLET	SA 106 GR C		SA 106 GR C	
6	VALVE BODY TYPE / MATERIAL / MINIMUM SIZE OF VALVE	GLOBE	A217WC6	6"	
7	GUIDING / NO. OF PORTS / TRIM FORM	CAGE	ONE	LINEAR	
8	CAGE TYPE / CAGE MATERIAL / GUIDE BUSH Material	STANDARD	17-4PH SS	17-4PH SS	
9	MATERIAL: PLUG / STEM/SEAT/YOKE	17-4PH SS	17-4PH SS	17-4PH SS	CARBON STEEL
10	PACKING MATERIAL / NOS / TYPE	GRAFOIL	SINGLE	STANDARD	
11	END CONNECTION / ANSI RATING / BONNET TYPE	BWE	600	STANDARD	
12	FLOW ACTION / VALVE OUTLET VELOCITY	< 7 M/SEC(WATER)			
13	LEAKAGE CLASS / NOISE LEVEL (dBA)	IV		< 85 dBA	
14	VACUUM SERVICE / ANTI CAVITATION TRIM	NO		NO	
15	ACTUATOR TYPE	PNEUMATIC WITH SMART POSITIONER (PROFIBUS)			
16	TRAVEL TIME FOR OPEN TO CLOSE, CLOSE TO OPEN	LESS THAN 10 SEC			
17	VALVE POSN. ON: ELECTRICAL SIGNAL FAILURE / SUPPLY AIR FAILURE	TO CLOSE		TO CLOSE	
18	SMART POSITIONER / POSITION LIMIT SWITCH	REQUIRED		REQUIRED	
19	POSITION TRANSMITTER / E/P CONVERTER	PART OF SMART POSITIONER		PART OF SMART POSITIONER	
20	AIR FILTER REGULATOR / AIR LOCK RELAY	REQUIRED		REQUIRED	
21	SOLENOID VALVE / JUNCTION BOX	REQUIRED		REQUIRED	
22	HAND WHEEL (SIDE MOUNTED) / LOCAL POSITIONER INDICATOR	REQUIRED		REQUIRED	
23	SERVICE CONDITIONS (LOAD)	FLOW (T/HR)	INLET PR KG/CM2(A)	OUTLET PR. KG/CM2(A)	TEMP DEG. C
24	40% LOAD	50.5	27.6	11.46	188.6
25	60% LOAD	80.4	39.5	16.3	205.7
26	100%LOAD	174	63.6	26.2	230.5
27	VWO	190.6	67.3	27.7	233.6
28	20%LOAD	29.3	15.6	6.8	163.3
29					
30					
31	MAX SHUT OFF PRESSURE,BODY DESIGN PRESSURE (KG/CM2 (g)), TEMP (DEG C)	76.7		76.7	240
32	IBR FORM-IIC	NOT REQUIRED			
33	PROCESS CONDITION	FLASHING			
D. GUARENTEED PERFORMANCE REQUIREMENTS					
34	LINEARITY / HYSTERISIS / SENSITIVITY / OVERALL ACCURACY	+/- 1%	+/- 1%	+/- 0.5%	+/- 2%
35	MODEL OF CONTROL VALVE	BIDDER TO FURNISH			
36	SIZE OF CONTROL VALVE	BIDDER TO FURNISH			

	TECHNICAL SPECIFICATION & DATA SHEET FOR CONTROL VALVE WITH ACCESSORIES (PNEUMATICALLY OPERATED)	Specification No.: PE-TS-497-145-H104			
		Rev. No. 00			
		Date :04.10.23			
SPECIFICATION & DATA SHEET FOR CONTROL VALVE					
A. GENERAL INFORMATION					
1	TAG NUMBER / SERVICE	DRV-31		LPH-3 ALT. DRAIN TO F/T	
2	LOCATION / DUTY	INDOOR		MODULATING	
B. DESIGN CODES & STANDARDS					
3	CODE / STANDARD	REFER SPECIFIC NOTES			
C. TECHNICAL PARAMETERS / DESIGN FEATURES					
4	PIPE SIZE (OD X THK) mm INLET / OUTLET	INLET	273 x 6.35	OUTLET	323.9 x 12.7
5	PIPE MATERIAL INLET / OUTLET	SA 106 GR B		SA 106 GR B	
6	VALVE BODY TYPE / MATERIAL / MINIMUM SIZE OF VALVE	GLOBE	A217WC9	6"	
7	GUIDING / NO. OF PORTS / TRIM FORM	CAGE	ONE	LINEAR	
8	CAGE TYPE / CAGE MATERIAL / GUIDE BUSH Material	STANDARD	440C	440C	
9	MATERIAL: PLUG / STEM/SEAT/YOKE	440C	440C	440C	CARBON STEEL
10	PACKING MATERIAL / NOS / TYPE	GRAFOIL	DOUBLE	V-CHEVRON	
11	END CONNECTION / ANSI RATING / BONNET TYPE	BWE	300	STANDARD	
12	FLOW ACTION / VALVE OUTLET VELOCITY	< 7 M/SEC(WATER)			
13	LEAKAGE CLASS / NOISE LEVEL (dBA)	V		< 85 dBA	
14	VACUUM SERVICE / ANTI CAVITATION TRIM	YES		NO	
15	ACTUATOR TYPE	PNEUMATIC WITH SMART POSITIONER (HART)			
16	TRAVEL TIME FOR OPEN TO CLOSE, CLOSE TO OPEN	LESS THAN 10 SEC			
17	VALVE POSN. ON: ELECTRICAL SIGNAL FAILURE / SUPPLY AIR FAILURE	TO OPEN		TO OPEN	
18	SMART POSITIONER / POSITION LIMIT SWITCH	REQUIRED		REQUIRED	
19	POSITION TRANSMITTER / E/P CONVERTER	PART OF SMART POSITIONER		PART OF SMART POSITIONER	
20	AIR FILTER REGULATOR / AIR LOCK RELAY	REQUIRED		REQUIRED	
21	SOLENOID VALVE / JUNCTION BOX	REQUIRED		REQUIRED	
22	HAND WHEEL (SIDE MOUNTED) / LOCAL POSITIONER INDICATOR	REQUIRED		REQUIRED	
23	SERVICE CONDITIONS (LOAD)	FLOW (T/HR)	INLET PR KG/CM2(A)	OUTLET PR. KG/CM2(A)	TEMP DEG. C
24	40% LOAD	71	1.1	0.2	88.6
25	60% LOAD	104.6	1.3	0.2	96.2
26	100%LOAD	192.4	1.6	0.2	107.4
27	VWO	206.8	1.6	0.2	108.7
28	20%LOAD	42.5	0.7	0.2	77.6
29					
30					
31	MAX SHUT OFF PRESSURE,BODY DESIGN PRESSURE (KG/CM2 (g)), TEMP (DEG C)	3.5		3.5/VACCUUM	115
32	IBR FORM-IIIC	NOT REQUIRED			
33	PROCESS CONDITION	FLASHING			
D. GUARENTEED PERFORMANCE REQUIREMENTS					
34	LINEARITY / HYSTERISIS / SENSITIVITY / OVERALL ACCURACY	+/- 1%	+/- 1%	+/- 0.5%	+/- 2%
35	MODEL OF CONTROL VALVE	BIDDER TO FURNISH			
36	SIZE OF CONTROL VALVE	BIDDER TO FURNISH			

	TECHNICAL SPECIFICATION & DATA SHEET FOR CONTROL VALVE WITH ACCESSORIES (PNEUMATICALLY OPERATED)	Specification No.: PE-TS-497-145-H104			
		Rev. No. 00			
		Date :04.10.23			
SPECIFICATION & DATA SHEET FOR CONTROL VALVE					
A. GENERAL INFORMATION					
1	TAG NUMBER / SERVICE	DRV-48		DEAERATOR OVERFLOW TO F/T	
2	LOCATION / DUTY	INDOOR		ON/OFF	
B. DESIGN CODES & STANDARDS					
3	CODE / STANDARD	REFER SPECIFIC NOTES			
C. TECHNICAL PARAMETERS / DESIGN FEATURES					
4	PIPE SIZE (OD X THK) mm INLET / OUTLET	INLET	219.1 x 6.35	OUTLET	323.9 x 9.53
5	PIPE MATERIAL INLET / OUTLET	SA 106 GR C		SA 106 GR C	
6	VALVE BODY TYPE / MATERIAL / MINIMUM SIZE OF VALVE	GLOBE	A217WC9	6"	
7	GUIDING / NO. OF PORTS / TRIM FORM	CAGE	ONE	ON-OFF(QUICK OPEN)	
8	CAGE TYPE / CAGE MATERIAL / GUIDE BUSH Material	STANDARD	440 C	440 C	
9	MATERIAL: PLUG / STEM/SEAT/YOKE	440 C	440 C	440 C	CARBON STEEL
10	PACKING MATERIAL / NOS / TYPE	GRAFOIL	DOUBLE	V-CHEVRON	
11	END CONNECTION / ANSI RATING / BONNET TYPE	BWE	300	STANDARD	
12	FLOW ACTION / VALVE OUTLET VELOCITY	< 7 M/SEC(WATER)			
13	LEAKAGE CLASS / NOISE LEVEL (dBA)	V		< 85 dBA	
14	VACUUM SERVICE / ANTI CAVITATION TRIM	YES		NO	
15	ACTUATOR TYPE	PNEUMATIC WITH SMART POSITIONER (PROFIBUS)			
16	TRAVEL TIME FOR OPEN TO CLOSE, CLOSE TO OPEN	LESS THAN 10 SEC			
17	VALVE POSN. ON: ELECTRICAL SIGNAL FAILURE / SUPPLY AIR FAILURE	TO OPEN		STAYPUT	
18	SMART POSITIONER / POSITION LIMIT SWITCH	NOT REQUIRED		REQUIRED	
19	POSITION TRANSMITTER / E/P CONVERTER	PART OF SMART POSITIONER		PART OF SMART POSITIONER	
20	AIR FILTER REGULATOR / AIR LOCK RELAY	REQUIRED		REQUIRED	
21	SOLENOID VALVE / JUNCTION BOX	REQUIRED		REQUIRED	
22	HAND WHEEL (SIDE MOUNTED) / LOCAL POSITIONER INDICATOR	REQUIRED		REQUIRED	
23	SERVICE CONDITIONS (LOAD)	FLOW (T/HR)	INLET PR KG/CM2(A)	OUTLET PR. KG/CM2(A)	TEMP DEG. C
24	MAX-1 10% BMCR	211	14.06	0.2	188.7
25	MAX-2 10% BMCR	211	5.37	0.2	139.7
26					
27					
28					
29					
30					
31	MAX SHUT OFF PRESSURE,BODY DESIGN PRESSURE (KG/CM2 (g)), TEMP (DEG C)	20		20/VACCUM	200
32	IBR FORM-IIIC	NOT REQUIRED			
33	PROCESS CONDITION	FLASHING			
D. GUARENTEED PERFORMANCE REQUIREMENTS					
34	LINEARITY / HYSTERISIS / SENSITIVITY / OVERALL ACCURACY	+/- 5%	+/- 5%	+/- 0.5%	+/- 2%
35	MODEL OF CONTROL VALVE	BIDDER TO FURNISH			
36	SIZE OF CONTROL VALVE	BIDDER TO FURNISH			

	TECHNICAL SPECIFICATION & DATA SHEET FOR CONTROL VALVE WITH ACCESSORIES (PNEUMATICALLY OPERATED)	Specification No.: PE-TS-497-145-H104			
		Rev. No. 00			
		Date :04.10.23			
SPECIFICATION & DATA SHEET FOR CONTROL VALVE					
A. GENERAL INFORMATION					
1	TAG NUMBER / SERVICE	DRV-5 & DRV-11		HPH-8A/8B ALT. DRAIN TO F/T	
2	LOCATION / DUTY	INDOOR		MODULATING	
B. DESIGN CODES & STANDARDS					
3	CODE / STANDARD	REFER SPECIFIC NOTES			
C. TECHNICAL PARAMETERS / DESIGN FEATURES					
4	PIPE SIZE (OD X THK) mm	INLET	273 x 12.7	OUTLET	323.9 x 12.7
5	PIPE MATERIAL INLET / OUTLET	SA 106 GR C		SA 106 GR C	
6	VALVE BODY TYPE / MATERIAL / MINIMUM SIZE OF VALVE	GLOBE	A217WC9	6"	
7	GUIDING / NO. OF PORTS / TRIM FORM	CAGE	ONE	LINEAR	
8	CAGE TYPE / CAGE MATERIAL / GUIDE BUSH Material	STANDARD	440C	440C	
9	MATERIAL: PLUG / STEM/SEAT/YOKE	440C	440C	440C	CARBON STEEL
10	PACKING MATERIAL / NOS / TYPE	GRAFOIL	DOUBLE	V-CHEVRON	
11	END CONNECTION / ANSI RATING / BONNET TYPE	BWE	600	STANDARD	
12	FLOW ACTION / VALVE OUTLET VELOCITY	< 7 M/SEC(WATER)			
13	LEAKAGE CLASS / NOISE LEVEL (dBA)	V		< 85 dBA	
14	VACUUM SERVICE / ANTI CAVITATION TRIM	YES		NO	
15	ACTUATOR TYPE	PNEUMATIC WITH SMART POSITIONER (HART)			
16	TRAVEL TIME FOR OPEN TO CLOSE, CLOSE TO OPEN	LESS THAN 10 SEC			
17	VALVE POSN. ON: ELECTRICAL SIGNAL FAILURE / SUPPLY AIR FAILURE	TO OPEN		TO OPEN	
18	SMART POSITIONER / POSITION LIMIT SWITCH	REQUIRED		REQUIRED	
19	POSITION TRANSMITTER / E/P CONVERTER	PART OF SMART POSITIONER		PART OF SMART POSITIONER	
20	AIR FILTER REGULATOR / AIR LOCK RELAY	REQUIRED		REQUIRED	
21	SOLENOID VALVE / JUNCTION BOX	REQUIRED		REQUIRED	
22	HAND WHEEL (SIDE MOUNTED) / LOCAL POSITIONER INDICATOR	REQUIRED		REQUIRED	
23	SERVICE CONDITIONS (LOAD)	FLOW (T/HR)	INLET PR KG/CM2(A)	OUTLET PR. KG/CM2(A)	TEMP DEG. C
24	40% LOAD	50.5	27.8	0.2	226.8
25	60% LOAD	80.4	39.6	0.2	247.5
26	100%LOAD	174	63.4	0.2	277.7
27	VWO	190.6	67	0.2	281.5
28	20%LOAD	29.3	15.5	0.2	198.2
29					
30					
31	MAX SHUT OFF PRESSURE,BODY DESIGN PRESSURE (KG/CM2 (g)), TEMP (DEG C)	76.7		76.7/VACCUUM	285
32	IBR FORM-IIIC	NOT REQUIRED			
33	PROCESS CONDITION	FLASHING,HIGH DP			
D. GUARENTEED PERFORMANCE REQUIREMENTS					
34	LINEARITY / HYSTERISIS / SENSITIVITY / OVERALL ACCURACY	+/- 1%	+/- 1%	+/- 0.5%	+/- 2%
35	MODEL OF CONTROL VALVE	BIDDER TO FURNISH			
36	SIZE OF CONTROL VALVE	BIDDER TO FURNISH			

	TECHNICAL SPECIFICATION & DATA SHEET FOR CONTROL VALVE WITH ACCESSORIES (PNEUMATICALLY OPERATED)	Specification No.: PE-TS-497-145-H104			
		Rev. No. 00			
		Date :04.10.23			
SPECIFICATION & DATA SHEET FOR CONTROL VALVE					
A. GENERAL INFORMATION					
1	TAG NUMBER / SERVICE	DRV-53 & DRV59		HPH-9A/9B NORMAL DRAIN TO HPH-8A/8B	
2	LOCATION / DUTY	INDOOR		MODULATING	
B. DESIGN CODES & STANDARDS					
3	CODE / STANDARD	REFER SPECIFIC NOTES			
C. TECHNICAL PARAMETERS / DESIGN FEATURES					
4	PIPE SIZE (OD X THK) mm	INLET	168.3 x 10.97	OUTLET	168.3 x 10.97
5	PIPE MATERIAL INLET / OUTLET	SA 106 GR C		SA 106 GR C	
6	VALVE BODY TYPE / MATERIAL / MINIMUM SIZE OF VALVE	GLOBE	A217WC6	3"	
7	GUIDING / NO. OF PORTS / TRIM FORM	CAGE	ONE	LINEAR	
8	CAGE TYPE / CAGE MATERIAL / GUIDE BUSH Material	STANDARD	17-4PH SS	17-4PH SS	
9	MATERIAL: PLUG / STEM/SEAT/YOKE	17-4PH SS	17-4PH SS	17-4PH SS	CARBON STEEL
10	PACKING MATERIAL / NOS / TYPE	GRAFOIL	SINGLE	STANDARD	
11	END CONNECTION / ANSI RATING / BONNET TYPE	BWE	900	STANDARD	
12	FLOW ACTION / VALVE OUTLET VELOCITY	< 7 M/SEC(WATER)			
13	LEAKAGE CLASS / NOISE LEVEL (dBA)	IV		< 85 dBA	
14	VACUUM SERVICE / ANTI CAVITATION TRIM	NO		NO	
15	ACTUATOR TYPE	PNEUMATIC WITH SMART POSITIONER (PROFIBUS)			
16	TRAVEL TIME FOR OPEN TO CLOSE, CLOSE TO OPEN	LESS THAN 10 SEC			
17	VALVE POSN. ON: ELECTRICAL SIGNAL FAILURE / SUPPLY AIR FAILURE	TO CLOSE		CLOSE	
18	SMART POSITIONER / POSITION LIMIT SWITCH	REQUIRED		REQUIRED	
19	POSITION TRANSMITTER / E/P CONVERTER	PART OF SMART POSITIONER		PART OF SMART POSITIONER	
20	AIR FILTER REGULATOR / AIR LOCK RELAY	REQUIRED		REQUIRED	
21	SOLENOID VALVE / JUNCTION BOX	REQUIRED		REQUIRED	
22	HAND WHEEL (SIDE MOUNTED) / LOCAL POSITIONER INDICATOR	REQUIRED		REQUIRED	
23	SERVICE CONDITIONS (LOAD)	FLOW (T/HR)	INLET PR. KG/CM2(A)	OUTLET PR. KG/CM2(A)	TEMP DEG. C
24	40% LOAD	18.5	39.9	27.1	231.4
25	60% LOAD	29.1	57.3	39.1	253.4
26	100%LOAD	67	92.5	63.4	283.5
27	VWO	74.2	98.4	67.2	287.8
28	20% LOAD	11.3	22.5	15.6	199.5
29					
30					
31	MAX SHUT OFF PRESSURE,BODY DESIGN PRESSURE (KG/CM2 (g)), TEMP (DEG C)	110		110	290
32	IBR FORM-IIIC	NOT REQUIRED			
33	PROCESS CONDITION	FLASHING			
D. GUARENTEED PERFORMANCE REQUIREMENTS					
34	LINEARITY / HYSTERISIS / SENSITIVITY / OVERALL ACCURACY	+/- 1%	+/- 1%	+/- 0.5%	+/- 2%
35	MODEL OF CONTROL VALVE	BIDDER TO FURNISH			
36	SIZE OF CONTROL VALVE	BIDDER TO FURNISH			

	TECHNICAL SPECIFICATION & DATA SHEET FOR CONTROL VALVE WITH ACCESSORIES (PNEUMATICALLY OPERATED)	Specification No.: PE-TS-497-145-H104			
		Rev. No. 00			
		Date :04.10.23			
SPECIFICATION & DATA SHEET FOR CONTROL VALVE					
A. GENERAL INFORMATION					
1	TAG NUMBER / SERVICE	DRV-56 & DRV-62		HPH-9A/9B ALT. DRAIN TO F/T	
2	LOCATION / DUTY	INDOOR		MODULATING	
B. DESIGN CODES & STANDARDS					
3	CODE / STANDARD	REFER SPECIFIC NOTES			
C. TECHNICAL PARAMETERS / DESIGN FEATURES					
4	PIPE SIZE (OD X THK) mm	INLET	168.3 x 10.97	OUTLET	219.1 x 12.7
5	PIPE MATERIAL INLET / OUTLET	SA 106 GR C		SA 106 GR C	
6	VALVE BODY TYPE / MATERIAL / MINIMUM SIZE OF VALVE	GLOBE	A217WC9	4"	
7	GUIDING / NO. OF PORTS / TRIM FORM	CAGE	ONE	LINEAR	
8	CAGE TYPE / CAGE MATERIAL / GUIDE BUSH Material	STANDARD	440C	440C	
9	MATERIAL: PLUG / STEM/SEAT/YOKE	440C	440C	440C	CARBON STEEL
10	PACKING MATERIAL / NOS / TYPE	GRAFOIL	DOUBLE	V-CHEVRON	
11	END CONNECTION / ANSI RATING / BONNET TYPE	BWE	900	STANDARD	
12	FLOW ACTION / VALVE OUTLET VELOCITY	< 7 M/SEC(WATER)			
13	LEAKAGE CLASS / NOISE LEVEL (dBA)	V		< 85 dBA	
14	VACUUM SERVICE / ANTI CAVITATION TRIM	YES		NO	
15	ACTUATOR TYPE	PNEUMATIC WITH SMART POSITIONER (HART)			
16	TRAVEL TIME FOR OPEN TO CLOSE, CLOSE TO OPEN	LESS THAN 10 SEC			
17	VALVE POSN. ON: ELECTRICAL SIGNAL FAILURE / SUPPLY AIR FAILURE	TO OPEN		TO OPEN	
18	SMART POSITIONER / POSITION LIMIT SWITCH	REQUIRED		REQUIRED	
19	POSITION TRANSMITTER / E/P CONVERTER	PART OF SMART POSITIONER		PART OF SMART POSITIONER	
20	AIR FILTER REGULATOR / AIR LOCK RELAY	REQUIRED		REQUIRED	
21	SOLENOID VALVE / JUNCTION BOX	REQUIRED		REQUIRED	
22	HAND WHEEL (SIDE MOUNTED) / LOCAL POSITIONER INDICATOR	REQUIRED		REQUIRED	
23	SERVICE CONDITIONS (LOAD)	FLOW (T/HR)	INLET PR KG/CM2(A)	OUTLET PR. KG/CM2(A)	TEMP DEG. C
24	40% LOAD	18.5	40.9	0.2	249
25	60% LOAD	29.1	58.1	0.2	271.5
26	100%LOAD	67	93.1	0.2	304.1
27	VWO	74.2	98.8	0.2	308.6
28	20%LOAD	11.3	23.1	0.2	218.1
29					
30					
31	MAX SHUT OFF PRESSURE,BODY DESIGN PRESSURE (KG/CM2 (g)), TEMP (DEG C)	110		110/VACCUUM	310
32	IBR FORM-IIC	NOT REQUIRED			
33	PROCESS CONDITION	FLASHING,HIGH DP			
D. GUARENTEED PERFORMANCE REQUIREMENTS					
34	LINEARITY / HYSTERISIS / SENSITIVITY / OVERALL ACCURACY	+/- 1%	+/- 1%	+/- 0.5%	+/- 2%
35	MODEL OF CONTROL VALVE	BIDDER TO FURNISH			
36	SIZE OF CONTROL VALVE	BIDDER TO FURNISH			

	TECHNICAL SPECIFICATION & DATA SHEET FOR CONTROL VALVE WITH ACCESSORIES (PNEUMATICALLY OPERATED)	Specification No.: PE-TS-497-145-H104			
		Rev. No. 00			
		Date :04.10.23			
SPECIFICATION & DATA SHEET FOR CONTROL VALVE					
A. GENERAL INFORMATION					
1	TAG NUMBER / SERVICE	DRV-65		LPH-4 NORMAL DRAIN TO LPH-3	
2	LOCATION / DUTY	INDOOR		MODULATING	
B. DESIGN CODES & STANDARDS					
3	CODE / STANDARD	REFER SPECIFIC NOTES			
C. TECHNICAL PARAMETERS / DESIGN FEATURES					
4	PIPE SIZE (OD X THK) mm INLET / OUTLET	INLET	219.1 x 6.35	OUTLET	219.1 x 12.7
5	PIPE MATERIAL INLET / OUTLET	SA 106 GR B		SA 106 GR B	
6	VALVE BODY TYPE / MATERIAL / MINIMUM SIZE OF VALVE	GLOBE	A217WC6	6"	
7	GUIDING / NO. OF PORTS / TRIM FORM	CAGE	ONE	LINEAR	
8	CAGE TYPE / CAGE MATERIAL / GUIDE BUSH Material	STANDARD	17-4PH SS	17-4PH SS	
9	MATERIAL: PLUG / STEM/SEAT/YOKE	17-4PH SS	17-4PH SS	17-4PH SS	CARBON STEEL
10	PACKING MATERIAL / NOS / TYPE	GRAFOIL	DOUBLE	V-CHEVRON	
11	END CONNECTION / ANSI RATING / BONNET TYPE	BWE	300	STANDARD	
12	FLOW ACTION / VALVE OUTLET VELOCITY	< 7 M/SEC(WATER)			
13	LEAKAGE CLASS / NOISE LEVEL (dBA)	IV		< 85 dBA	
14	VACUUM SERVICE / ANTI CAVITATION TRIM	YES		NO	
15	ACTUATOR TYPE	PNEUMATIC WITH SMART POSITIONER (PROFIBUS)			
16	TRAVEL TIME FOR OPEN TO CLOSE, CLOSE TO OPEN	LESS THAN 10 SEC			
17	VALVE POSN. ON: ELECTRICAL SIGNAL FAILURE / SUPPLY AIR FAILURE	TO CLOSE		TO CLOSE	
18	SMART POSITIONER / POSITION LIMIT SWITCH	REQUIRED		REQUIRED	
19	POSITION TRANSMITTER / E/P CONVERTER	PART OF SMART POSITIONER		PART OF SMART POSITIONER	
20	AIR FILTER REGULATOR / AIR LOCK RELAY	REQUIRED		REQUIRED	
21	SOLENOID VALVE / JUNCTION BOX	REQUIRED		REQUIRED	
22	HAND WHEEL (SIDE MOUNTED) / LOCAL POSITIONER INDICATOR	REQUIRED		REQUIRED	
23	SERVICE CONDITIONS (LOAD)	FLOW (T/HR)	INLET PR KG/CM2(A)	OUTLET PR. KG/CM2(A)	TEMP DEG. C
24	40% LOAD	43.4	1.52	0.8	90
25	60% LOAD	64.2	2	1.2	98
26	100%LOAD	119.7	2.81	1.6	109.7
27	VWO	128.7	2.86	1.7	111.3
28	20%LOAD	25.8	0.59	0.7	78.5
29					
30					
31	MAX SHUT OFF PRESSURE,BODY DESIGN PRESSURE (KG/CM2 (g)), TEMP (DEG C)	7		7/VACCUUM	115
32	IBR FORM-IIIC	NOT REQUIRED			
33	PROCESS CONDITION	FLASHING			
D. GUARENTEED PERFORMANCE REQUIREMENTS					
34	LINEARITY / HYSTERISIS / SENSITIVITY / OVERALL ACCURACY	+/- 1%	+/- 1%	+/- 0.5%	+/- 2%
35	MODEL OF CONTROL VALVE	BIDDER TO FURNISH			
36	SIZE OF CONTROL VALVE	BIDDER TO FURNISH			

	TECHNICAL SPECIFICATION & DATA SHEET FOR CONTROL VALVE WITH ACCESSORIES (PNEUMATICALLY OPERATED)	Specification No.: PE-TS-497-145-H104			
		Rev. No. 00			
		Date :04.10.23			
SPECIFICATION & DATA SHEET FOR CONTROL VALVE					
A. GENERAL INFORMATION					
1	TAG NUMBER / SERVICE	DRV-68		LPH-4 ALT. DRAIN TO F/T	
2	LOCATION / DUTY	INDOOR		MODULATING	
B. DESIGN CODES & STANDARDS					
3	CODE / STANDARD	REFER SPECIFIC NOTES			
C. TECHNICAL PARAMETERS / DESIGN FEATURES					
4	PIPE SIZE (OD X THK) mm INLET / OUTLET	INLET	219.1 x 6.35	OUTLET	219.1 x 12.7
5	PIPE MATERIAL INLET / OUTLET	SA 106 GR B		SA 106 GR B	
6	VALVE BODY TYPE / MATERIAL / MINIMUM SIZE OF VALVE	GLOBE	A217WC9	6"	
7	GUIDING / NO. OF PORTS / TRIM FORM	CAGE	ONE	LINEAR	
8	CAGE TYPE / CAGE MATERIAL / GUIDE BUSH Material	STANDARD	440C	440C	
9	MATERIAL: PLUG / STEM/SEAT/YOKE	440C	440C	440C	CARBON STEEL
10	PACKING MATERIAL / NOS / TYPE	GRAFOIL	DOUBLE	V-CHEVRON	
11	END CONNECTION / ANSI RATING / BONNET TYPE	BWE	300	STANDARD	
12	FLOW ACTION / VALVE OUTLET VELOCITY	< 7 M/SEC(WATER)			
13	LEAKAGE CLASS / NOISE LEVEL (dBA)	V		< 85 dBA	
14	VACUUM SERVICE / ANTI CAVITATION TRIM	YES		NO	
15	ACTUATOR TYPE	PNEUMATIC WITH SMART POSITIONER (HART)			
16	TRAVEL TIME FOR OPEN TO CLOSE, CLOSE TO OPEN	LESS THAN 10 SEC			
17	VALVE POSN. ON: ELECTRICAL SIGNAL FAILURE / SUPPLY AIR FAILURE	TO OPEN		TO OPEN	
18	SMART POSITIONER / POSITION LIMIT SWITCH	REQUIRED		REQUIRED	
19	POSITION TRANSMITTER / E/P CONVERTER	PART OF SMART POSITIONER		PART OF SMART POSITIONER	
20	AIR FILTER REGULATOR / AIR LOCK RELAY	REQUIRED		REQUIRED	
21	SOLENOID VALVE / JUNCTION BOX	REQUIRED		REQUIRED	
22	HAND WHEEL (SIDE MOUNTED) / LOCAL POSITIONER INDICATOR	REQUIRED		REQUIRED	
23	SERVICE CONDITIONS (LOAD)	FLOW (T/HR)	INLET PR. KG/CM2(A)	OUTLET PR. KG/CM2(A)	TEMP DEG. C
24	40% LOAD	43.4	1.9	0.2	110.8
25	60% LOAD	64.2	2.3	0.2	120.1
26	100%LOAD	119.7	3.2	0.2	133.3
27	VWO	128.7	3.4	0.2	135
28	20%LOAD	25.8	1.1	0.2	96.7
29					
30					
31	MAX SHUT OFF PRESSURE,BODY DESIGN PRESSURE (KG/CM2 (g)), TEMP (DEG C)	7		7/VACCUUM	140
32	IBR FORM-IIIC	NOT REQUIRED			
33	PROCESS CONDITION	FLASHING			
D. GUARENTEED PERFORMANCE REQUIREMENTS					
34	LINEARITY / HYSTERISIS / SENSITIVITY / OVERALL ACCURACY	+/- 1%	+/- 1%	+/- 0.5%	+/- 2%
35	MODEL OF CONTROL VALVE	BIDDER TO FURNISH			
36	SIZE OF CONTROL VALVE	BIDDER TO FURNISH			

	TECHNICAL SPECIFICATION & DATA SHEET FOR CONTROL VALVE WITH ACCESSORIES (PNEUMATICALLY OPERATED)	Specification No.: PE-TS-497-145-H104			
		Rev. No. 00			
		Date :04.10.23			
SPECIFICATION & DATA SHEET FOR CONTROL VALVE					
A. GENERAL INFORMATION					
1	TAG NUMBER / SERVICE	DRV-77		LPH-3 DRAIN D/S OF DRIP PUMP	
2	LOCATION / DUTY	INDOOR		MODULATING	
B. DESIGN CODES & STANDARDS					
3	CODE / STANDARD	REFER SPECIFIC NOTES			
C. TECHNICAL PARAMETERS / DESIGN FEATURES					
4	PIPE SIZE (OD X THK) mm INLET / OUTLET	INLET	168.3 x 7.11	OUTLET	168.3 x 7.11
5	PIPE MATERIAL INLET / OUTLET	SA 106 GR B		SA 106 GR B	
6	VALVE BODY TYPE / MATERIAL / MINIMUM SIZE OF VALVE	GLOBE	A216WCB	6"	
7	GUIDING / NO. OF PORTS / TRIM FORM	CAGE	ONE	LINEAR	
8	CAGE TYPE / CAGE MATERIAL / GUIDE BUSH Material	STANDARD	SS 316 STELLITED	SS 316 STELLITED	
9	MATERIAL: PLUG / STEM/SEAT/YOKE	SS 316 STELLITED	SS 316 STELLITED	SS 316 STELLITED	CARBON STEEL
10	PACKING MATERIAL / NOS / TYPE	GRAFOIL	DOUBLE	STANDARD	
11	END CONNECTION / ANSI RATING / BONNET TYPE	BWE	300	STANDARD	
12	FLOW ACTION / VALVE OUTLET VELOCITY	< 7 M/SEC(WATER)			
13	LEAKAGE CLASS / NOISE LEVEL (dBA)	IV		< 85 dBA	
14	VACUUM SERVICE / ANTI CAVITATION TRIM	NO		NO	
15	ACTUATOR TYPE	PNEUMATIC WITH SMART POSITIONER (PROFIBUS)			
16	TRAVEL TIME FOR OPEN TO CLOSE, CLOSE TO OPEN	LESS THAN 10 SEC			
17	VALVE POSN. ON: ELECTRICAL SIGNAL FAILURE / SUPPLY AIR FAILURE	TO CLOSE		TO CLOSE	
18	SMART POSITIONER / POSITION LIMIT SWITCH	REQUIRED		REQUIRED	
19	POSITION TRANSMITTER / E/P CONVERTER	PART OF SMART POSITIONER		PART OF SMART POSITIONER	
20	AIR FILTER REGULATOR / AIR LOCK RELAY	REQUIRED		REQUIRED	
21	SOLENOID VALVE / JUNCTION BOX	REQUIRED		REQUIRED	
22	HAND WHEEL (SIDE MOUNTED) / LOCAL POSITIONER INDICATOR	REQUIRED		REQUIRED	
23	SERVICE CONDITIONS (LOAD)	FLOW (T/HR)	INLET PR KG/CM2(A)	OUTLET PR. KG/CM2(A)	TEMP DEG. C
24	40% LOAD	71	26.7	10	88.5
25	60% LOAD	104.6	26.6	12.5	96.2
26	100% LOAD	192.4	25.4	18.3	107.3
27	VWO	206.8	24.9	19.3	108.8
28	20% LOAD	42.5	26.6	7.2	77.5
29					
30					
31	MAX SHUT OFF PRESSURE,BODY DESIGN PRESSURE (KG/CM2 (g)), TEMP (DEG C)	50		50	130
32	IBR FORM-IIIC	NOT REQUIRED			
33	PROCESS CONDITION				
D. GUARENTEED PERFORMANCE REQUIREMENTS					
34	LINEARITY / HYSTERISIS / SENSITIVITY / OVERALL ACCURACY	+/- 1%	+/- 1%	+/- 0.5%	+/- 2%
35	MODEL OF CONTROL VALVE	BIDDER TO FURNISH			
36	SIZE OF CONTROL VALVE	BIDDER TO FURNISH			

	TECHNICAL SPECIFICATION & DATA SHEET FOR CONTROL VALVE WITH ACCESSORIES (PNEUMATICALLY OPERATED)	Specification No.: PE-TS-497-145-H104			
		Rev. No. 00			
		Date :04.10.23			
SPECIFICATION & DATA SHEET FOR CONTROL VALVE					
A. GENERAL INFORMATION					
1	TAG NUMBER / SERVICE	DRV-82		LPH-5 NORMAL DRAIN TO LPH-4	
2	LOCATION / DUTY	INDOOR		MODULATING	
B. DESIGN CODES & STANDARDS					
3	CODE / STANDARD	REFER SPECIFIC NOTES			
C. TECHNICAL PARAMETERS / DESIGN FEATURES					
4	PIPE SIZE (OD X THK) mm	INLET	168.3 x 7.11	OUTLET	219.1 x 12.7
5	PIPE MATERIAL INLET / OUTLET	SA 106 GR B		SA 106 GR B	
6	VALVE BODY TYPE / MATERIAL / MINIMUM SIZE OF VALVE	GLOBE	A217WC6	6"	
7	GUIDING / NO. OF PORTS / TRIM FORM	CAGE	ONE	LINEAR	
8	CAGE TYPE / CAGE MATERIAL / GUIDE BUSH Material	STANDARD	17-4PH SS	17-4PH SS	
9	MATERIAL: PLUG / STEM/SEAT/YOKE	17-4PH SS	17-4PH SS	17-4PH SS	CARBON STEEL
10	PACKING MATERIAL / NOS / TYPE	GRAFOIL	DOUBLE	V-CHEVRON	
11	END CONNECTION / ANSI RATING / BONNET TYPE	BWE	300	STANDARD	
12	FLOW ACTION / VALVE OUTLET VELOCITY	< 7 M/SEC(WATER)			
13	LEAKAGE CLASS / NOISE LEVEL (dBA)	IV		< 85 dBA	
14	VACUUM SERVICE / ANTI CAVITATION TRIM	YES		NO	
15	ACTUATOR TYPE	PNEUMATIC WITH SMART POSITIONER (PROFIBUS)			
16	TRAVEL TIME FOR OPEN TO CLOSE, CLOSE TO OPEN	LESS THAN 10 SEC			
17	VALVE POSN. ON: ELECTRICAL SIGNAL FAILURE / SUPPLY AIR FAILURE	TO CLOSE		TO CLOSE	
18	SMART POSITIONER / POSITION LIMIT SWITCH	REQUIRED		REQUIRED	
19	POSITION TRANSMITTER / E/P CONVERTER	PART OF SMART POSITIONER		PART OF SMART POSITIONER	
20	AIR FILTER REGULATOR / AIR LOCK RELAY	REQUIRED		REQUIRED	
21	SOLENOID VALVE / JUNCTION BOX	REQUIRED		REQUIRED	
22	HAND WHEEL (SIDE MOUNTED) / LOCAL POSITIONER INDICATOR	REQUIRED		REQUIRED	
23	SERVICE CONDITIONS (LOAD)	FLOW (T/HR)	INLET PR KG/CM2(A)	OUTLET PR. KG/CM2(A)	TEMP DEG. C
24	40% LOAD	19.9	2.7	1.6	112.1
25	60% LOAD	29.7	3.6	2.3	121.5
26	100%LOAD	56.5	5.3	3.3	135.3
27	VWO	60.9	5.5	3.5	137.1
28	20%LOAD	12	1.3	1.2	97.7
29					
30					
31	MAX SHUT OFF PRESSURE,BODY DESIGN PRESSURE (KG/CM2 (g)), TEMP (DEG C)	7		7	145
32	IBR FORM-IIIC	NOT REQUIRED			
33	PROCESS CONDITION	FLASHING			
D. GUARENTEED PERFORMANCE REQUIREMENTS					
34	LINEARITY / HYSTERISIS / SENSITIVITY / OVERALL ACCURACY	+/- 1%	+/- 1%	+/- 0.5%	+/- 2%
35	MODEL OF CONTROL VALVE	BIDDER TO FURNISH			
36	SIZE OF CONTROL VALVE	BIDDER TO FURNISH			

	TECHNICAL SPECIFICATION & DATA SHEET FOR CONTROL VALVE WITH ACCESSORIES (PNEUMATICALLY OPERATED)	Specification No.: PE-TS-497-145-H104			
		Rev. No. 00			
		Date :04.10.23			
SPECIFICATION & DATA SHEET FOR CONTROL VALVE					
A. GENERAL INFORMATION					
1	TAG NUMBER / SERVICE	DRV-85		LPH-5 ALT. DRAIN TO F/T	
2	LOCATION / DUTY	INDOOR		MODULATING	
B. DESIGN CODES & STANDARDS					
3	CODE / STANDARD	REFER SPECIFIC NOTES			
C. TECHNICAL PARAMETERS / DESIGN FEATURES					
4	PIPE SIZE (OD X THK) mm	INLET	168.3 x 7.11	OUTLET	219.1 x 12.7
5	PIPE MATERIAL INLET / OUTLET	SA 106 GR B		SA 106 GR B	
6	VALVE BODY TYPE / MATERIAL / MINIMUM SIZE OF VALVE	GLOBE	A217WC9	6"	
7	GUIDING / NO. OF PORTS / TRIM FORM	CAGE	ONE	LINEAR	
8	CAGE TYPE / CAGE MATERIAL / GUIDE BUSH Material	STANDARD	440C	440C	
9	MATERIAL: PLUG / STEM/SEAT/YOKE	440C	440C	440C	CARBON STEEL
10	PACKING MATERIAL / NOS / TYPE	GRAFOIL	DOUBLE	V-CHEVRON	
11	END CONNECTION / ANSI RATING / BONNET TYPE	BWE	300	STANDARD	
12	FLOW ACTION / VALVE OUTLET VELOCITY	< 7 M/SEC(WATER)			
13	LEAKAGE CLASS / NOISE LEVEL (dBA)	V		< 85 dBA	
14	VACUUM SERVICE / ANTI CAVITATION TRIM	YES		NO	
15	ACTUATOR TYPE	PNEUMATIC WITH SMART POSITIONER (HART)			
16	TRAVEL TIME FOR OPEN TO CLOSE, CLOSE TO OPEN	LESS THAN 10 SEC			
17	VALVE POSN. ON: ELECTRICAL SIGNAL FAILURE / SUPPLY AIR FAILURE	TO OPEN		TO OPEN	
18	SMART POSITIONER / POSITION LIMIT SWITCH	REQUIRED		REQUIRED	
19	POSITION TRANSMITTER / E/P CONVERTER	PART OF SMART POSITIONER		PART OF SMART POSITIONER	
20	AIR FILTER REGULATOR / AIR LOCK RELAY	REQUIRED		REQUIRED	
21	SOLENOID VALVE / JUNCTION BOX	REQUIRED		REQUIRED	
22	HAND WHEEL (SIDE MOUNTED) / LOCAL POSITIONER INDICATOR	REQUIRED		REQUIRED	
23	SERVICE CONDITIONS (LOAD)	FLOW (T/HR)	INLET PR KG/CM2(A)	OUTLET PR. KG/CM2(A)	TEMP DEG. C
24	40% LOAD	19.9	3.1	0.2	129.1
25	60% LOAD	29.7	4	0.2	139.7
26	100%LOAD	56.5	5.8	0.2	155.1
27	VWO	60.9	6	0.2	157.1
28	20%LOAD	12	1.8	0.2	112.9
29					
30					
31	MAX SHUT OFF PRESSURE,BODY DESIGN PRESSURE (KG/CM2 (g)), TEMP (DEG C)	7		7/VACCUUM	165
32	IBR FORM-IIIC	NOT REQUIRED			
33	PROCESS CONDITION	FLASHING			
D. GUARENTEED PERFORMANCE REQUIREMENTS					
34	LINEARITY / HYSTERISIS / SENSITIVITY / OVERALL ACCURACY	+/- 1%	+/- 1%	+/- 0.5%	+/- 2%
35	MODEL OF CONTROL VALVE	BIDDER TO FURNISH			
36	SIZE OF CONTROL VALVE	BIDDER TO FURNISH			

	TECHNICAL SPECIFICATION & DATA SHEET FOR CONTROL VALVE WITH ACCESSORIES (PNEUMATICALLY OPERATED)		Specification No.: PE-TS-497-145-H104		
			Rev. No. 00		
			Date :04.10.23		
SPECIFICATION & DATA SHEET FOR CONTROL VALVE					
A. GENERAL INFORMATION					
1	TAG NUMBER / SERVICE	10PGC36AA101		DMCW SYSYSTEM FOR SG AUX'S	
2	LOCATION / DUTY	INDOOR		MODULATING	
B. DESIGN CODES & STANDARDS					
3	CODE / STANDARD	REFER SPECIFIC NOTES			
C. TECHNICAL PARAMETERS / DESIGN FEATURES					
4	PIPE SIZE (OD X THK) mm INLET / OUTLET	INLET	457.0X6.0	OUTLET	457.0X6.0
5	PIPE MATERIAL INLET / OUTLET	CS IS 2062		CS IS 2062	
6	VALVE BODY TYPE / MATERIAL / MINIMUM SIZE OF VALVE	GLOBE	A216WCB	14"	
7	GUIDING / NO. OF PORTS / TRIM FORM	CAGE	ONE	LINEAR	
8	CAGE TYPE / CAGE MATERIAL / GUIDE BUSH Material	STANDARD	SS 316 STELLITED	SS 316 STELLITED	
9	MATERIAL: PLUG / STEM/SEAT/YOKE	SS 316 STELLITED	SS 316 STELLITED	SS 316 STELLITED	CARBON STEEL
10	PACKING MATERIAL / NOS / TYPE	GRAFOIL	SINGLE	STANDARD	
11	END CONNECTION / ANSI RATING / BONNET TYPE	BWE	300	STANDARD	
12	FLOW ACTION / VALVE OUTLET VELOCITY	< 7 M/SEC(WATER)			
13	LEAKAGE CLASS / NOISE LEVEL (dBA)	IV		< 85 dBA	
14	VACUUM SERVICE / ANTI CAVITATION TRIM	NO		NO	
15	ACTUATOR TYPE	PNEUMATIC WITH SMART POSITIONER (PROFIBUS)			
16	TRAVEL TIME FOR OPEN TO CLOSE, CLOSE TO OPEN	LESS THAN 10 SEC			
17	VALVE POSN. ON: ELECTRICAL SIGNAL FAILURE / SUPPLY AIR FAILURE	STAYPUT		STAYPUT	
18	SMART POSITIONER / POSITION LIMIT SWITCH	REQUIRED		REQUIRED	
19	POSITION TRANSMITTER / E/P CONVERTER	PART OF SMART POSITIONER		PART OF SMART POSITIONER	
20	AIR FILTER REGULATOR / AIR LOCK RELAY	REQUIRED		REQUIRED	
21	SOLENOID VALVE / JUNCTION BOX	REQUIRED		REQUIRED	
22	HAND WHEEL (SIDE MOUNTED) / LOCAL POSITIONER INDICATOR	REQUIRED		REQUIRED	
23	SERVICE CONDITIONS (LOAD)	FLOW (T/HR)	INLET PR KG/CM2(A)	OUTLET PR. KG/CM2(A)	TEMP DEG. C
24	NORMAL	1129	7.1	4.3	38
25	MINIMUM	0	7.1	4.3	38
26	MAX SHUT OFF PRESSURE,BODY DESIGN PRESSURE (KG/CM2 (g)), TEMP (DEG C)	8.2		10	60
27	IBR FORM-IIC				
28	PROCESS CONDITION	HIGH DP			
D. GUARENTEED PERFORMANCE REQUIREMENTS					
29	LINEARITY / HYSTERISIS / SENSITIVITY / OVERALL ACCURACY	+/- 1%	+/- 1%	+/- 0.5%	+/- 2%
30	MODEL OF CONTROL VALVE	BIDDER TO FURNISH			
31	SIZE OF CONTROL VALVE	BIDDER TO FURNISH			

	TECHNICAL SPECIFICATION & DATA SHEET FOR CONTROL VALVE WITH ACCESSORIES (PNEUMATICALLY OPERATED)	Specification No.: PE-TS-497-145-H104			
		Rev. No. 00			
		Date :04.10.23			
SPECIFICATION & DATA SHEET FOR CONTROL VALVE					
A. GENERAL INFORMATION					
1	TAG NUMBER / SERVICE	10PGC15AA101		DMCW SYSSYTEM FOR TG AUX'S	
2	LOCATION / DUTY	INDOOR		MODULATING	
B. DESIGN CODES & STANDARDS					
3	CODE / STANDARD	REFER SPECIFIC NOTES			
C. TECHNICAL PARAMETERS / DESIGN FEATURES					
4	PIPE SIZE (OD X THK) mm INLET / OUTLET	INLET	406.4X6.0	OUTLET	406.4X6.0
5	PIPE MATERIAL INLET / OUTLET	CS IS 2062		CS IS 2062	
6	VALVE BODY TYPE / MATERIAL / MINIMUM SIZE OF VALVE	GLOBE	A216WCB	12"	
7	GUIDING / NO. OF PORTS / TRIM FORM	CAGE	ONE	LINEAR	
8	CAGE TYPE / CAGE MATERIAL / GUIDE BUSH Material	STANDARD	SS 316 STELLITED	SS 316 STELLITED	
9	MATERIAL: PLUG / STEM/SEAT/YOKE	SS 316 STELLITED	SS 316 STELLITED	SS 316 STELLITED	CARBON STEEL
10	PACKING MATERIAL / NOS / TYPE	GRAFOIL	SINGLE	STANDARD	
11	END CONNECTION / ANSI RATING / BONNET TYPE	BWE	300	STANDARD	
12	FLOW ACTION / VALVE OUTLET VELOCITY	< 7 M/SEC(WATER)			
13	LEAKAGE CLASS / NOISE LEVEL (dBA)	IV		< 85 dBA	
14	VACUUM SERVICE / ANTI CAVITATION TRIM	NO		NO	
15	ACTUATOR TYPE	PNEUMATIC WITH SMART POSITIONER (PROFIBUS)			
16	TRAVEL TIME FOR OPEN TO CLOSE, CLOSE TO OPEN	LESS THAN 10 SEC			
17	VALVE POSN. ON: ELECTRICAL SIGNAL FAILURE / SUPPLY AIR FAILURE	STAYPUT		STAYPUT	
18	SMART POSITIONER / POSITION LIMIT SWITCH	REQUIRED		REQUIRED	
19	POSITION TRANSMITTER / E/P CONVERTER	PART OF SMART POSITIONER		PART OF SMART POSITIONER	
20	AIR FILTER REGULATOR / AIR LOCK RELAY	REQUIRED		REQUIRED	
21	SOLENOID VALVE / JUNCTION BOX	REQUIRED		REQUIRED	
22	HAND WHEEL (SIDE MOUNTED) / LOCAL POSITIONER INDICATOR	REQUIRED		REQUIRED	
23	SERVICE CONDITIONS (LOAD)	FLOW (T/HR)	INLET PR. KG/CM2(A)	OUTLET PR. KG/CM2(A)	TEMP DEG. C
24	NORMAL	999	5	2.7	38
25	MINIMUM	0	5	2.7	38
26	MAX SHUT OFF PRESSURE,BODY DESIGN PRESSURE (KG/CM2 (g)), TEMP (DEG C)	6		10	60
27	IBR FORM-III C				
28	PROCESS CONDITION	HIGH DP			
D. GUARENTEED PERFORMANCE REQUIREMENTS					
29	LINEARITY / HYSTERISIS / SENSITIVITY / OVERALL ACCURACY	+/- 1%	+/- 1%	+/- 0.5%	+/- 2%
30	MODEL OF CONTROL VALVE	BIDDER TO FURNISH			
31	SIZE OF CONTROL VALVE	BIDDER TO FURNISH			

 MANUFACTURER/BIDDER/ SUPPLIER NAME & ADDRESS		STANDARD QUALITY PLAN					SPEC. NO : --			DATE: --			
		CUSTOMER : NTPC					QP NO.: PE-QP-999-145-H 006 REV 00			DATE: 06.07.2023			
		PROJECT: --2X660MW TALCHER STP					PO NO.: --			DATE: --			
		ITEM: CONTROL VALVE			SYSTEM: S&CE		SECTION: C			SHEET 1 OF 9			
SL NO.	COMPONENT & OPERATIONS	CHARACTERISTIC CHECKED	CATE GORY	TYPE OF CHECK	QUANTUM OF CHECK		REFERENCE DOCUMENT	ACCEPTANCE NORMS	FORMAT OF RECORD	AGENCY			REMARKS
1	2	3	4	5	6		7	8	9	*	**		
					M	B/C				D	M	B	C

1.0 RAW MATERIAL													
1.1	Body & Bonnet castings/forgings ,plug, valve stem, seat ring/cage	Physical, Chemical properties	MA	Physical, Chemical tests	100%	10%	Approved drg/ datasheet	Approved drg/data sheet	Test Certificate	√	P/W	V	
		Heat Treatment	MA	Review of H.T. Certificate	100%	10%	Approved drg/datasheet	Approved drg/data sheet	Test Certificate	√	P/W	V	Applicable for body /bonnet only
		Internal quality of castings/forgings	MA	RT for Body & UT for Bonnet	100%	10%	ASME B 16.34	ASME B 16.34	Test Report/ Film	√	P/W	V	Applicable for body and bonnet for rating ANSI 900 and above.
		Surface Quality	MA	1.Visual	100%	10%	ANSI/ MSS-SP-55	ANSI/ MSS-SP-55	Inspection Report	√	P/W	V	Applicable for body/bonnet only.
		Pressure Test for shell	MA	Hyd. Test	100%	10%	ISA-S-75.19	ISA-S-75.19	Inspection Report	√	P/W	V	For Body and Bonnet after machining.

BHEL					
ENGINEERING			QUALITY		
	Sign & Date	Name		Sign & Date	Name
Prepared by:		CHETAN MALIK	Checked by:		
Reviewed by:		SS BANSALA	Reviewed by:		

BIDDER/ SUPPLIER	
Sign & Date	
Seal	

FOR CUSTOMER REVIEW & APPROVAL			
Doc No:			
	Sign & Date	Name	Seal
Reviewed by:			
Approved by:			

	MANUFACTURER/BIDDER/ SUPPLIER NAME & ADDRESS			STANDARD QUALITY PLAN				SPEC. NO : --			DATE: --		
				CUSTOMER : NTPC				QP NO.: PE-QP-999-145-H 006 REV 00			DATE: 06.07.2023		
				PROJECT: --2X660MW TALCHER STP				PO NO.: --			DATE: --		
				ITEM: CONTROL VALVE		SYSTEM: S&CE		SECTION: C			SHEET 2 OF 9		

SL NO.	COMPONENT & OPERATIONS	CHARACTERISTIC CHECKED	CATEGORY	TYPE OF CHECK	QUANTUM OF CHECK		REFERENCE DOCUMENT	ACCEPTANCE NORMS	FORMAT OF RECORD	AGENCY			REMARKS	
1	2	3	4	5	6		7	8	9	*	**			
					M	B/C				D	M	B	C	

1.2	Diaphragm	Surface Quality	MA	Visual	100%	10%	Mfr. standard	COC./Test Certificate	COC/Test Certificate	√	P/V	V	
		Hardness	MA	Measurement	100%	10%	Mfr. standard	COC/Test Certificate	COC/Test Certificate	√	P/V	V	
		Endurance/ Life cycle	MA	Cyclic Test 10,000 cycles	One/ type	One/ type	Mfr. standard	No damage	COC/Test Certificate	√	P/V	V	
1.3	Spring	Composition	MA	Chemical-Analysis	One Sample/ Heat	One Sample/ Heat	Mfr. Standard	COC/Test Certificate	COC/Test Certificate	√	P/V	V	
		Mech. Properties	MA	Mech. Test	One Sample/ Heat	One Sample/ Heat	Mfr. Standard	COC/Test Certificate	COC/Test Certificate	√	P/V	V	
		Performance	MA	1.Stiffness Ratio	100%	10%	Mfr. standard	COC/Test Certificate	COC/Test Certificate	√	P/V	V	
				2.Scragging	100%	10%	Mfr. standard	COC/Test Certificate	COC/Test Certificate	√	P/V	V	
				3.Cyclic Test (Endurance)	One/ type	One/ type	Mfr. standard	COC/Test Certificate	COC/Test Certificate	√	P/V	V	
4. Dimension (Measurement)	One sample/ Lot			One sample /Lot	Mfr. Standard	COC/Test Certificate	COC/Test Certificate	√	P/V	V			

BHEL					
ENGINEERING			QUALITY		
Sign & Date	Name		Sign & Date	Name	
Prepared by:	CHETAN MALIK		Checked by:		
Reviewed by:	SS BANSALA		Reviewed by:		

BIDDER/ SUPPLIER	
Sign & Date	
Seal	

FOR CUSTOMER REVIEW & APPROVAL			
Doc No:			
Sign & Date	Name	Seal	
Reviewed by:			
Approved by:			

	MANUFACTURER/BIDDER/ SUPPLIER NAME & ADDRESS			STANDARD QUALITY PLAN				SPEC. NO : --			DATE: --		
				CUSTOMER : NTPC				QP NO.: PE-QP-999-145-H 006 REV 00			DATE: 06.07.2023		
				PROJECT: --2X660MW TALCHER STP				PO NO.: --			DATE: --		
				ITEM: CONTROL VALVE		SYSTEM: S&CE		SECTION: C			SHEET 3 OF 9		

SL NO.	COMPONENT & OPERATIONS	CHARACTERISTIC CHECKED	CATE GORY	TYPE OF CHECK	QUANTUM OF CHECK		REFERENCE DOCUMENT	ACCEPTANCE NORMS	FORMAT OF RECORD	AGENCY	REMARKS
1	2	3	4	5	6		7	8	9	* D	** M B C

--	--	--	--	--	--	--	--	--	--	--	--

2.0 IN PROCESS INSPECTION

2.1	After machining, i, Body ii Bonnet iii Plug iv Valve Stem v seat ring vi cage	Surface flaws	MA	Visual & MT/PT	100% (on accessi ble surfaces)	10%	ASME B 16.34	ASME B 16.34	Inspection Report	√	P/ W	V	Butt weld ends shall be included.
		Dimensional checks	MA	Measurement	100%	10%	Appd Drg.	Appd Drg.	Inspection Report	√	P/ W	V	
		Hard Facing (wherever applicable)	MA	Hardness Measurement	One sample/ Lot	One sample /Lot	Appd Datasheet	Appd Datasheet	Inspection Report	√	P/ W	V	

FINAL TESTING/INSPECTION

3.0 TESTS ON COMPLETED VALVE

3.1	Actuator Chamber	Leakage	MA	Pneumatic Test	100%	10%	Mfr. standard	No Leakage	Test Certificate	√	P/ W	W	
3.2	Body	Leakage (Body	MA	Hydro Test	100%	10%	ISA-S-75.19/	No Leakage	Test	√	P/ W	W	

BHEL				BIDDER/ SUPPLIER		FOR CUSTOMER REVIEW & APPROVAL			
ENGINEERING		QUALITY		Sign & Date		Doc No:			
Sign & Date	Name	Sign & Date	Name	Seal		Sign & Date	Name	Seal	
Prepared by:	CHETAN MALIK	Checked by:				Reviewed by:			
Reviewed by:	SS BANSALA	Reviewed by:				Approved by:			

 MANUFACTURER/BIDDER/ SUPPLIER NAME & ADDRESS		STANDARD QUALITY PLAN					SPEC. NO : --			DATE: --				
		CUSTOMER : NTPC					QP NO.: PE-QP-999-145-H 006 REV 00			DATE: 06.07.2023				
		PROJECT: --2X660MW TALCHER STP					PO NO.: --			DATE: --				
		ITEM: CONTROL VALVE		SYSTEM: S&CE			SECTION: C			SHEET 4 OF 9				
SL NO.	COMPONENT & OPERATIONS	CHARACTERISTIC CHECKED	CATE GORY	TYPE OF CHECK	QUANTUM OF CHECK		REFERENCE DOCUMENT	ACCEPTANCE NORMS	FORMAT OF RECORD	AGENCY			REMARKS	
1	2	3	4	5	6		7	8	9	*	**			
					M	B/C				D	M	B	C	

3.3	Seat Leakage	Mount Leakage)							Certificate					
	Seat Leakage	Seat Leakage	MA	Pneumatic / WaterTest	100%	10%	FCI-70.2	Approved Datasheet	Test Certificate	√	P/W	W		
4.0	OPERATION TEST ON COMPLETED VALVE ASSEMBLY	Valve Travel	MA	Measurement	100%	10%	Approved datasheet	Approved Datasheet	Inspection Report	√	P/W	W		
		Opening / Closing Time	MA	Measurement	100%	10%	Approved datasheet	Approved Datasheet	Inspection Report	√	P/W	W		
		Linearity / Cam characteristic	MA	Measurement	100%	10%	Approved datasheet	Approved Datasheet	Inspection Report	√	P/W	W		
		Repeatability	MA	Measurement	100%	10%	Approved datasheet	Approved Datasheet	Inspection Report	√	P/W	W		
		Hysteresis	MA	Measurement	100%	10%	Approved datasheet	Approved Datasheet	Inspection Report	√	P/W	W		
		Sensitivity	MA	Measurement	100%	10%	Approved datasheet	Approved Datasheet	Inspection Report	√	P/W	W		
		Accuracy(Overall)	MA	Measurement	100%	10%	Approved datasheet	Approved Datasheet	Inspection Report	√	P/W	W		
		Control Valve characteristics / CV Test	MA	◆ Measurement (Press. vs. discharge and discharge vs opening 0-100% in steps of 10%)	One per type	One per type	Mfr. Procedure	Approved Datasheet	Test Certificate	√	P/W	V		
Operation of limit switch & solenoids and	MA	Function	100%	10%	Mfr. Procedure	Approved Datasheet	Inspection Report	√	P/W	W		On assembled Valve.		

BHEL						BIDDER/ SUPPLIER		FOR CUSTOMER REVIEW & APPROVAL			
ENGINEERING			QUALITY			Sign & Date		Doc No:			
Prepared by:	Sign & Date	Name	Checked by:	Sign & Date	Name	Seal		Sign & Date	Name	Seal	
Reviewed by:		CHETAN MALIK	Reviewed by:								
Reviewed by:		SS BANSALA	Reviewed by:								

	MANUFACTURER/BIDDER/ SUPPLIER NAME & ADDRESS			STANDARD QUALITY PLAN				SPEC. NO : --			DATE: --			
				CUSTOMER : NTPC				QP NO.: PE-QP-999-145-H 006 REV 00			DATE: 06.07.2023			
				PROJECT: --2X660MW TALCHER STP				PO NO.: --			DATE: --			
				ITEM: CONTROL VALVE		SYSTEM: S&CE		SECTION: C			SHEET 5 OF 9			
SL NO.	COMPONENT & OPERATIONS	CHARACTERISTIC CHECKED	CATEGORY	TYPE OF CHECK	QUANTUM OF CHECK		REFERENCE DOCUMENT	ACCEPTANCE NORMS	FORMAT OF RECORD	AGENCY			REMARKS	
1	2	3	4	5	6		7	8	9	*	**			
					M	B/C				D	M	B	C	

		other accessories												
		Overall dimensions	MI	Visual and dimensional	100%	10%	Approved drg	Approved drg	Inspection Report	√	P/W	W		
		Pre-defined valve position in case of air / signal failure	MI	Visual and dimensional	100%	10%	Approved data sheet	Approved data sheet	Inspection Report	√	P/W	W		
		Cleanliness, painting, stamping (for direction of flow), Tag No.	MA	Visual and dimensional, paint thickness	100%	10%	Approved drg /data sheet	Approved drg/data sheet	Test Certificate	√	P/W	W		
5.0	AUXILIARY ITEMS(Performance test of auxiliary items shall be performed on the completely assembled valve) – Refer NOTE-7													
5.1	Air Filter Regulator	Performance Test	MA	Measurement	Each type	Each type	Mfr. Standard	No leakage	--	√	P/V			
		Overall leakage	MA	Visual(soap solution)	100 %	10%	Mfr. Standard	No leakage	--	√	P/V			
5.2	Air lock relay	Performance Test	MA	Leakage test	100%	10%	Mfr. Standard	No leakage	--	√	P/V			
5.3	Smart Positioner	Physical Verification Make/Model	MA	Visual	100%	10%	Approved drg/datasheet	Approved drg/data sheet	--	√	P/V			

BHEL					
ENGINEERING			QUALITY		
	Sign & Date	Name		Sign & Date	Name
Prepared by:		CHETAN MALIK	Checked by:		
Reviewed by:		SS BANSALA	Reviewed by:		

BIDDER/ SUPPLIER	
Sign & Date	
Seal	

FOR CUSTOMER REVIEW & APPROVAL			
Doc No:			
	Sign & Date	Name	Seal
Reviewed by:			
Approved by:			

	MANUFACTURER/BIDDER/ SUPPLIER NAME & ADDRESS			STANDARD QUALITY PLAN				SPEC. NO : --			DATE: --		
				CUSTOMER : NTPC				QP NO.: PE-QP-999-145-H 006 REV 00			DATE: 06.07.2023		
				PROJECT: --2X660MW TALCHER STP				PO NO.: --			DATE: --		
				ITEM: CONTROL VALVE		SYSTEM: S&CE		SECTION: C			SHEET 6 OF 9		
SL NO.	COMPONENT & OPERATIONS	CHARACTERISTIC CHECKED	CATE GORY	TYPE OF CHECK	QUANTUM OF CHECK		REFERENCE DOCUMENT	ACCEPTANCE NORMS	FORMAT OF RECORD	AGENCY	REMARKS		
1	2	3	4	5	6		7	8	9	*	**		
					M	B/C				D	M B C		

		Degree of Protection	MA	IP/NEMA test	Each type	Each type	Relevant Standard	Relevant Standard	--	√	P/V		
		Calibration	MA	Measurement	Each type	Each type	Mfr. Standard	Mfr. Standard	--	√	P/V		
5.7	Electrical items	Routine Test	MA	HV, IR, Continuity function	100%	10%	Approved Data sheet	Approved Data sheet	--	√	P/V		
	(i) Limit Switches	Degree of protection	MA	IP/NEMA Tests	One sample/ type	One sample/ Lot	Approved Data sheet	Approved Data sheet	--	√	P/V		
	(ii) Solenoids	Routine Test	MA	HV, IR, Continuity function	100%	10%	Approved Data sheet	Approved Data sheet	--	√	P/V		
		Degree of protection	MA	IP/NEMA Tests	One sample/ type	One sample /Lot	Approved Data sheet	Approved Data sheet	--	√	P/V		
	(iii)Position Transmitter(if provided externally)	Routine Test	MA	HV, IR, Continuity function	100%	10%	Approved Data sheet	Approved Data sheet	--	√	P/V		
		Degree of protection	MA	IP/NEMA Tests	One sample/ type	One sample /Lot	Approved Data sheet	Approved Data sheet	--	√	P/V		

BHEL					
ENGINEERING			QUALITY		
	Sign & Date	Name		Sign & Date	Name
Prepared by:		CHETAN MALIK	Checked by:		
Reviewed by:		SS BANSALA	Reviewed by:		

BIDDER/ SUPPLIER	
Sign & Date	
Seal	

FOR CUSTOMER REVIEW & APPROVAL			
Doc No:			
	Sign & Date	Name	Seal
Reviewed by:			
Approved by:			

 MANUFACTURER/BIDDER/ SUPPLIER NAME & ADDRESS		STANDARD QUALITY PLAN					SPEC. NO : --		DATE: --		
		CUSTOMER : NTPC					QP NO.: PE-QP-999-145-H 006 REV 00		DATE: 06.07.2023		
		PROJECT: --2X660MW TALCHER STP					PO NO.: --		DATE: --		
		ITEM: CONTROL VALVE		SYSTEM: S&CE			SECTION: C		SHEET 7 OF 9		
SL NO.	COMPONENT & OPERATIONS	CHARACTERISTIC CHECKED	CATE GORY	TYPE OF CHECK	QUANTUM OF CHECK		REFERENCE DOCUMENT	ACCEPTANCE NORMS	FORMAT OF RECORD	AGENCY	REMARKS
1	2	3	4	5	6		7	8	9	* D	** M B C
					M	B/C					

6.0	PAINTING	Paint Thickness	MA	Measurement DFT check	100%	10%	Approved drg/data sheet	Approved drg/data sheet	Inspection Report	√	P/W		
7.0	PACKING	Soundness of Packing against transit damage	MA	Visual	100%	100%	Approved drg/data sheet	Approved drg/data sheet	Inspection Report	√	P/W	V	

NOTES:

- Cv test shall be conducted at FCRI/ laboratory approved by Govt. Of India/BHEL approved Laboratory. Alternatively, valid Cv test certificate for a similar control valve (same size, same Cv, same trim characteristics) can be accepted subject to acceptance by Customer.
- IBR certificates in Form III-C shall be submitted if called for in the specification/datasheet.
- Copies of all TC's (Test Certificates) for materials duly correlated with Heat Nos., TC's for electrical items and mechanical tests(Leak/Operation), C.O.C's (Certificates of Conformance) shall be submitted to BHEL for verification and acceptance.
- Valve manufacturer to arrange for COC (Certificates of Conformance) for the tests w.r.t. control valve accessories mentioned at Sl. No. 5 of the QAP.

LEGENDS:
 *RECORDS, IDENTIFIED WITH "TICK"(√) SHALL BE ESSENTIALLY INCLUDED BY SUPPLIER IN QA DOCUMENTATION,
 ** M: SUPPLIER / MANUFACTURER/ SUB-SUPPLIER/SUB-CONTRACTOR, , B: BHEL/ BHEL NOMINATED THIRD PARTY INSPECTION AGENCY, C: CUSTOMER, P:PERFORM,W:WITNESS, V:VERIFICATION,AS APPROPRIATE MA:MAJOR,MI:MINOR,CR:CRITICAL,RT-RADIOGRAPHIC TEST,UT-ULTRASONIC TEST,PT-DYE PENETRANT TEST,MT-MAGNETIC PARTICLE TEST

BHEL						BIDDER/ SUPPLIER		FOR CUSTOMER REVIEW & APPROVAL			
ENGINEERING			QUALITY			Sign & Date		Doc No:			
Prepared by:	Sign & Date	Name	Checked by:	Sign & Date	Name	Seal		Sign & Date	Name	Seal	
Reviewed by:		CHETAN MALIK	Reviewed by:								
Reviewed by:		SS BANSALA	Reviewed by:								

	TECHNICAL SPECIFICATION & DATA SHEET FOR CONTROL VALVE WITH ACCESSORIES (PNEUMATICALLY OPERATED)	Specification No.: PE-TS-497-145-H104			
		Rev. No. 00			
		Date : 04.10.23			

DATA SHEET FOR CONTROL VALVE ACCESSORIES TO BE CONFIRMED BY BIDDER

1	SMART POSITIONER	SMART POSITIONER (HART / PROFIBUS). Refer detailed Specification			
2	AFR CASING MATERIAL / FILTER SIZE / INLET - OUTLET PRESSURE (KG/CM2) / OUTPUT GAUGE	SINTERED BRONZE	5 MICRON	5.0 - 8.0	REQUIRED
3	AIR LOCK INLET-OUTLET PRESSURE (KG/CM2) / AFR AUTO DRAIN FEATURE	5.0 - 8.0		REQUIRED	
4	AIR LOCK RESET TYPE / VENT PLUG	AUTO		REQUIRED	
5	LIMIT SWITCH POSITION NO. / CONTACT TYPE / ENCLOSURE CLASS / CONTACT RATING	4(2-OPEN, 2- CLOSE)	4 X SPDT	IP-65	0.5A, 24 V DC / 5A, 230 V AC
6	SOV BODY MATERIAL / OPERATION / VOLTAGE / TYPE	BRASS	STAYPUT	24 V DC	3 WAY (UNIVERSAL OPERATION TYPE)
7	SOV COIL INSULATION CLASS / ENCLOSURE CLASS	H		IP-65	
8	JB MATERIAL / NO OF WAYS / ENCLOSURE CLASS	4 mm thick FRP	36	IP-65	
9	JB CABLE GLAND TYPE / MATERIAL / QUANTITY (PER CV) / JB TB TYPE	YES- DOUBLE COMPRESSION	Ni-PLATED	TWO	CAGE CLAMP
10	HAND WHEEL MOUNTING POSITION / POSITION INDICATOR / LOCAL POSITION INDICATOR	SIDE MOUNTED	REQUIRED	REQUIRED	
11	TUBING (ADDITIONAL TO INTEGRAL TUBING) / MATERIAL / SIZE / LENGTH IN METRES (PER CV)	REQUIRED	SS 316	1/4 "	12
12	FITTINGS AS PER HOOK UP DIAGRAM / FOR CONNECTION TO AIR FILTER REGULATOR	REQUIRED		REQUIRED	
13	FITTINGS FOR CONNECTION TO AIR LOCK RELAY / FOR CONNECTION TO IA HEADER ISOLATION VALVE	REQUIRED		REQUIRED	
14	EQUAL TEES / CONNECTORS	REQUIRED		REQUIRED	
15	VALVE DIAGNOSTIC AND CONFIGURATION SOFTWARE	REQUIRED		REQUIRED	

		TECHNICAL SPECIFICATION & DATA SHEET FOR CONTROL VALVE WITH ACCESSORIES (PNEUMATICALLY OPERATED)		Specification No.: PE-TS-497-145-H104	
				Rev. No. 00	
				Date : 04.10.23	
CONTROL VALVES COMPLETE WITH POSITIONER AND ALL ACCESSORIES MOUNTED, TUBED AND TERMINATED ON JB					
[A]	MAIN SUPPLY				
SR. NO.	TAG NO	DESCRIPTION	QTY/UNIT	TOTAL QTY FOR 2 UNITS	
1	ASV-8	D/A Pegging from Aux. Steam Header (ASV-8)	1	2	
2	CRHV-6	D/A Pegging from CRH Line (CRHV-6)	1	2	
3	CDV-25	Condensate Control valve (CDV-25)	1	2	
4	CDV-65	CEP-A Minimum Recirculation (CDV-65)	1	2	
5	CDV-67	CEP-B Minimum Recirculation (CDV-67)	1	2	
6	CDV-69	CEP-C Minimum Recirculation (CDV-69)	1	2	
7	CDV-39	GSC min. flow recirculation (CDV-39)	1	2	
8	CDV-43	Excess Dump Control (CDV-43)	1	2	
9	CDV-72	Condensate Spray for Valve Gland Sealing AND F/T- A (CDV-72)	1	2	
10	CDV-84	Condensate Spray for F/T-B (CDV-84)	1	2	
11	CDV-94	CONDENSATE FOR UNIT FLASH TANK SPRAY (CDV-94)	1	2	
12	DRV-53	HPH-9A Drain to HPH-8A (DRV-53)	1	2	
13	DRV-59	HPH-9B Drain to HPH-8B (DRV-59)	1	2	
14	DRV-56	HPH-9A ALT. DRAIN TO F/T (DRV-56)	1	2	
15	DRV-62	HPH-9B ALT. DRAIN TO F/T (DRV-62)	1	2	
16	DRV-2	HPH-8A Drain to HPH-7A (DRV-2)	1	2	
17	DRV-8	HPH-8B Drain to HPH-7B (DRV-8)	1	2	
18	DRV-5	HPH-8A ALT. DRAIN TO F/T (DRV-5)	1	2	
19	DRV-11	HPH-8B ALT. DRAIN TO F/T (DRV-11)	1	2	
20	DRV-15	HPH-7A NORMAL DRAIN TO DEAERATOR (DRV-15)	1	2	
21	DRV-22	HPH-7B NORMAL DRAIN TO DEAERATOR (DRV-22)	1	2	
22	DRV-18	HPH-7A ALT. DRAIN TO F/T (DRV-18)	1	2	
23	DRV-25	HPH-7B ALT. DRAIN TO F/T (DRV-25)	1	2	
24	DRV-77	LPH-3 DRAIN D/S OF DRIP PUMP (DRV-77)	1	2	
25	DRV-31	LPH-3 ALT. DRAIN TO F/T (DRV-31)	1	2	
26	DRV-48	DEAERATOR OVERFLOW TO F/T (DRV-48)	1	2	
27	DRV-65	LPH-4 Drain to LPH-3 (DRV-65)	1	2	
28	DRV-68	LPH-4 Drain to F/T (DRV-68)	1	2	
29	DRV-82	LPH-5 Drain to LPH-4 (DRV-82)	1	2	
30	DRV-85	LPH-5 Drain to F/T (DRV-85)	1	2	
31	DMV-43	NORMAL DM MU TO HOTWELL (DMV-43)	1	2	
32	DMV-78	EMERGENCY DM MU TO HOTWELL (DMV-78)	1	2	
33	PGC36AA101	DMCW SYSTEM FOR SG AUX'S	1	2	
34	PGC15AA101	DMCW SYSTEM FOR TG AUX'S	1	2	
[B]	1/4 " SS TUBING (12 METER FOR EACH TAG)		408 MTR	816 MTR	
[C]	SS FITTINGS- FOR EACH TAG		1 LOT	2 LOT	
1	SS FITTINGS for connection to Air Filter Regulator- FOR EACH TAG		1 LOT	2 LOT	
2	SS FITTINGS for connection to Air Lock Relay- FOR EACH TAG		1 LOT	2 LOT	
3	SS FITTINGS for connection to IA Header Isolation Valve - FOR EACH TAG		1 LOT	2 LOT	
4	SS EQUAL TEE - FOR EACH TAG		1 LOT	2 LOT	
5	SS 1/2 " NPT(M) X 1/4 " OD TUBE CONNECTOR- FOR EACH TAG		1 LOT	2 LOT	
[D]	CV TEST CHARGES FOR EACH CONTROL VALVE		1 LOT	1 LOT	
[E]	VALVE DIAGNOSTIC AND CONFIGURATION SOFTWARE (FOR ALL TAGS)		1 LOT	1 LOT	

	TECHNICAL SPECIFICATION & DATA SHEET FOR CONTROL VALVE WITH ACCESSORIES (PNEUMATICALLY OPERATED)	Specification No.: PE-TS-497-145-H104
		Rev. No. 00
		Date : 04.10.23
LIST OF COMMISSIONING SPARES		
S NO	ITEM DESCRIPTION	QUANTITY FOR STATION
1	Gaskets	One (1) set with each control valve tag
2	Gland Packing	One (1) set with each control valve tag

LIST OF MANDATORY SPARES		
Sr. No.	Description	Qty FOR STATION
1	Pneumatic and electro-hydraulic actuator assembly	1 No. of each type, model and rating
2	Diaphragms, O' rings, seals etc.	5 Nos. of all types make etc.
3	Solenoid valves (if applicable)	2 no of each type
4	Smart positioners (complete unit) & accessories (link assembly) (each type)	2 Nos. of each type, model and rating
5	Pneumatic air-filter/Regulator	2 Nos. of each type, make rating etc.
6	Air lock relays	2 nos. of each type
Additional Requirement of spares for SG DMCW valve		
7	Valve trim (including cage, plug, stem, seat rings, guide bushings, gland packing, gaskets etc.)	1 set for each type of control valve. 5 Sets each for gland packing and gaskets for all control valves.
Additional Requirement of spares for CEP min recirculation valve		
8	CEP recirculation valve trim which includes spindle with cone, seat ring, guide bush, cage	1 Set
9	CEP recirculation valve soft parts i.e. gland packing, seals, O-rings, gaskets etc.	3 Set

NOTES

1. Wherever the quantities have been indicated for each type, size, thickness, material, radius, range etc., these shall cover all the items supplied and installed and the breakup for these shall be furnished in the bid. In case spares indicated in the list are not applicable to the particular design offered by the bidder, the bidder should offer spares applicable to offered design with quantities generally in line with the approach followed in the above list.



TECHNICAL SPECIFICATION & DATA SHEET FOR CONTROL VALVE WITH ACCESSORIES (PNEUMATICALLY OPERATED)	Specification No.: PE-TS-497-145-H104 Rev. No. 00
	Date : 04.10.23

SPECIFICATIONS FOR MICROPROCESSOR BASED SMART POSITIONER

1	Electrical	a) Input Demand Signal	4-20 mA for HART compatible; Soft Signal for Profibus
		b) Power Supply	Loop Powered from the output card of Control System.
		c) HART / Profibus Protocol	Compatibility for Remote Calibration & Diagnostics (Super-imposed HART signal on input Signal 4-20 mA and Profibus
		d. Valve position sensing	Position sensing: 4-20 mA output signal for HART and soft signal for Profibus compatible
2	Environment	a) Operating temp.	(-)30 To 80 Deg. C
		b) Humidity	0-95 %
		c) Protection class	IP-65 Minimum
3	Software for Configuration and Diagnostics	Software	Software shall meet the requirements for Configuration, Diagnostics, Calibration and Testing of the actuator.
		Diagnostic/Test features	Advanced diagnostic features like Stroke counter or Travel counter, Leakage in actuators, Valve Signature analysis, Step Response test, Valve friction /Jamming detection etc to be provided.
4	Test reports/ Certificates	Factory Valve Signature Tests Reports (Pr Vs Valve travel and Travel Vs I/P signal) are to be provided. Test certificates as per Manufacture Standard/Relevant Standard are to be submitted.	
5	Configuration/ Calibration.	Remote & Local Calibration, Auto & Manual Calibration shall be possible.	
6	Operating Range	Full range/ Split range.	
7	Modes	Valve Action	Direct / Reverse Valve Action
		Flow Characterization	Possible to fit Valve Characteristic Curves- Linear , Equal percentage etc.
8	Fail Safe/Fail Freeze	Fail Safe/Fail Freeze feature is to be provided. (In case the fail freeze feature is not intrinsic to the positioner, Bidder shall achieve the same externally through solenoid valve connected in the pneumatic circuit).	
9	Pneumatic	Air capacity	Sufficient to handle the valves & actuators selected/ Boosters to be supplied, if required.
		Air pressure	To suit the air supply pressure/quality available.
		Process connection	½" NPT
10	Performance	Characteristic deviation	<=0.5 % of span.
		Ambient temp effect	<=0.01 %/ deg C or better.
11	EMC & CE Compliance	Required to International Standard like EN/IEC.	EN50081-2 & EN50082 or equivalent.
12	Accessories	In-built Operator Panel	Display with push buttons for configuration and display on the positioner itself (Password protected/Hardware lock).
		Press Gauge Block	For supply & output pressures, Air Filter Regulator and other accessories shall be provided on as required basis for making system complete.
		Electrical Cable Entry	1/2"NPT, side or bottom entry to avoid water ingress
		Valves Mounting Assembly	For-Single acting/Double acting actuators on as required basis

STANDARD CONTROL VALVE HOOK-UP DIAGRAM (WITH SMART POSITIONER)

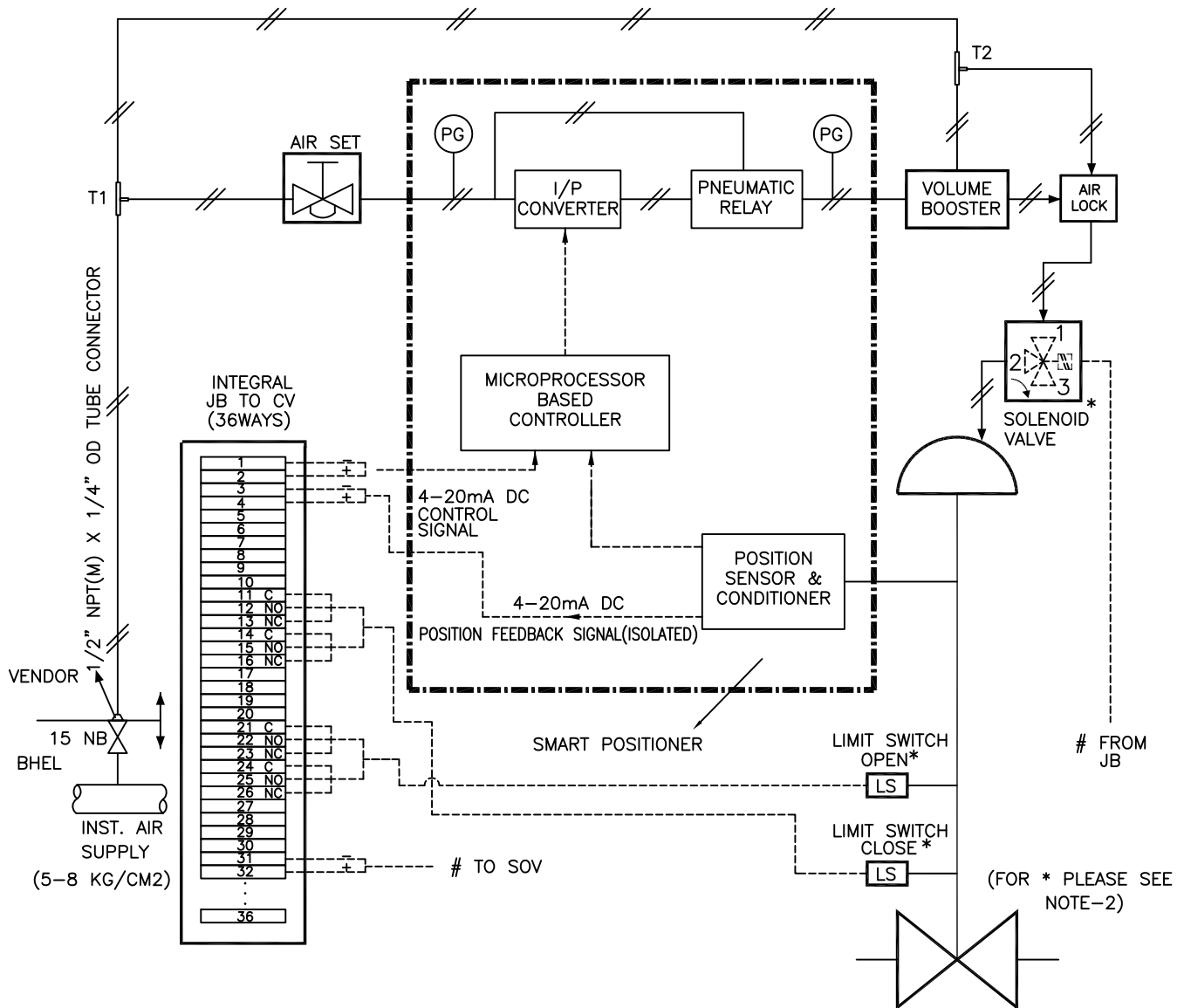

NOTES :-

1. POSITION OF EACH VALVE ON SUPPLY AIR FAILURE / ELECTRICAL SIGNAL FAILURE SHALL BE AS PER SPECIFICATION / DATA SHEET.
2. SOLENOID VALVE & LIMIT SWITCHES WILL BE PROVIDED ONLY FOR CONTROL VALVES IF INDICATED IN RESPECTIVE DATA SHEETS.
3. SOLENOID VALVES PORTS CONDITION:
PORT 1 AND 2 SHALL BE CONNECTED UNDER DE-ENERGISED CONDITION.
PORT 2 AND 3 SHALL BE CONNECTED UNDER ENERGISED CONDITION.
4. PRESSURE GAUGES REQUIRED FOR AIR SUPPLY & OUTPUT(S).
5. MOUNTING ACCESSORIES AS REQUIRED.
6. POSITION FEEDBACK SIGNAL SHALL BE 2 WIRE 4-20mA ISOLATED SIGNAL.
7. JB TERMINALS SHALL BE CAGE CLAMP TYPE SUITABLE FOR 2.5 SQ. MM COPPER WIRE. EXTERNAL CONNECTION, OF PLUG IN TYPE OR THROUGH CABLE GLAND, SHALL BE AS PER DATA SHEET
8. ALL APPLICABLE ACCESSORIES SHALL BE PROVIDED AS INDICATED IN THE INDIVIDUAL CONTROL VALVE DATA SHEET / ACCESSORIES DATA SHEET.
9. 12 METERS 1/4" SS TUBING (AS PER ACCESSORIES DATA SHEET) & 1 SET OF FITTINGS TO BE SUPPLIED FOR EACH CONTROL VALVE FOR CONNECTION TO ISO VLV AT INST AIR HEADER ON ONE END AND TO AIR LOCK RELAY/AIR FILTER REGULATOR ON THE OTHER END. ALL THE BRASS / SS FITTINGS SHALL BE DOUBLE COMPRESSION TYPE.
10. VOLUME BOOSTER (ALONG WITH TEE-T2 AND RELATED TUBING & CONNECTORS) SHALL BE PROVIDED IF REQUIRED. AIR CONNECTION TO VOLUME BOOSTER FROM TEE-T2 SHALL BE PROVIDED.



STANDARD CONTROL VALVE HOOK-UP DIAGRAM (FOR ON / OFF TYPE)

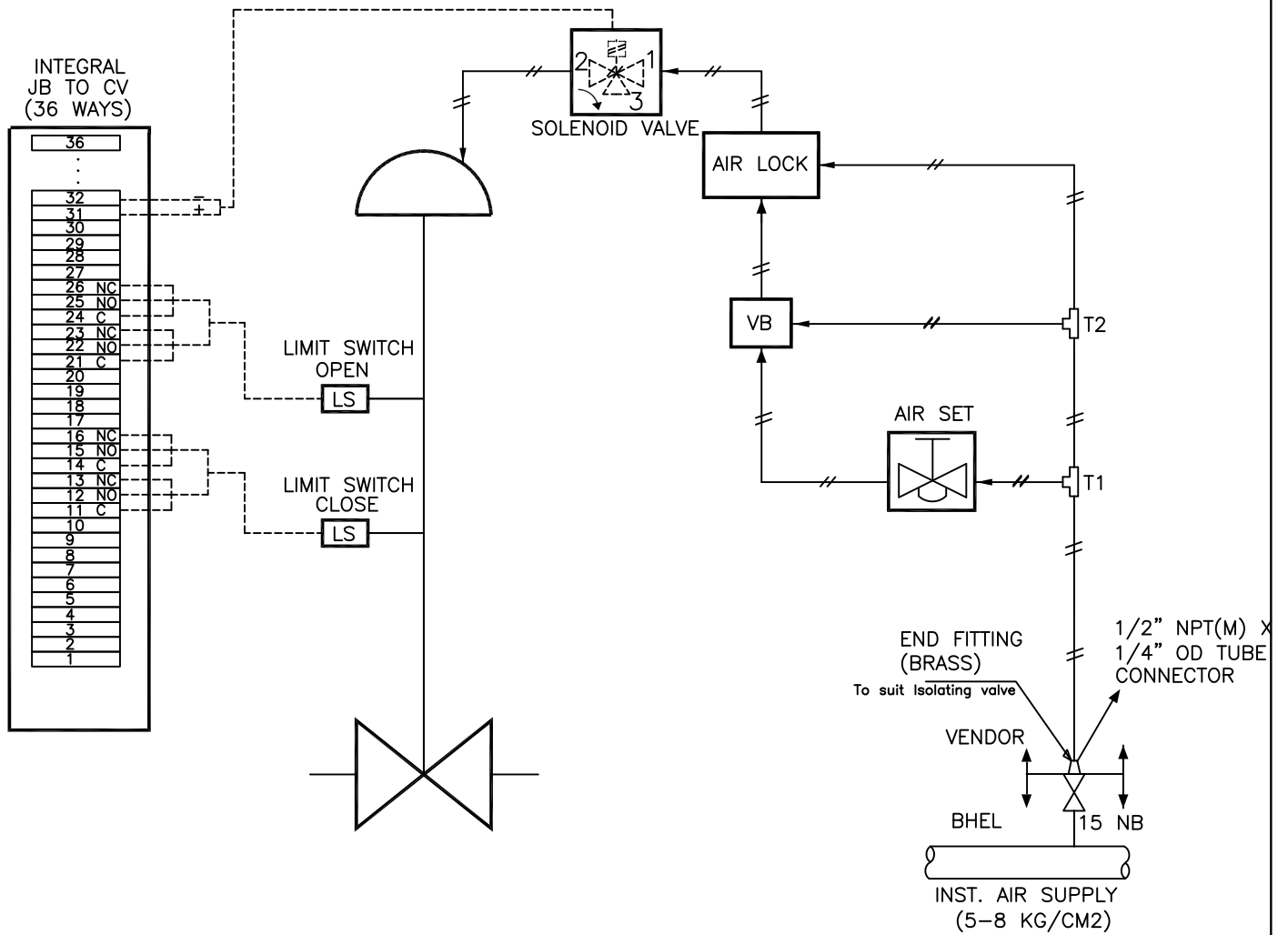

NOTES :-

1. POSITION OF EACH VALVE ON SUPPLY AIR FAILURE / ELECTRIC SIGNAL FAILURE SHALL BE AS PER SPECIFICATION / DATA SHEET.
2. SOLENOID VALVES PORTS CONDITION:
PORT 1 AND 2 SHALL BE CONNECTED UNDER DE-ENERGISED CONDITION.
PORT 2 AND 3 SHALL BE CONNECTED UNDER ENERGISED CONDITION.
3. MOUNTING ACCESSORIES AS REQUIRED.
4. JB TERMINALS SHALL BE CAGE CLAMP TYPE SUITABLE FOR 2.5 SQ. MM COPPER WIRE. EXTERNAL CONNECTION, OF PLUG IN TYPE OR THROUGH CABLE GLAND, SHALL BE AS PER DATA SHEET.
5. ALL APPLICABLE ACCESSORIES SHALL BE PROVIDED AS INDICATED IN THE INDIVIDUAL CONTROL VALVE DATA SHEET / ACCESSORIES DATA SHEET.
6. 12 METERS 1/4" SS TUBING (AS PER ACCESSORIES DATA SHEET) & 1 SET OF FITTINGS TO BE SUPPLIED FOR EACH CONTROL VALVE FOR CONNECTION TO ISO VLV AT INST AIR HEADER ON ONE END AND TO AIR LOCK RELAY/AIR FILTER REGULATOR ON THE OTHER END. ALL THE BRASS / SS FITTINGS SHALL BE DOUBLE COMPRESSION TYPE.



STANDARD CONTROL VALVE HOOK-UP DIAGRAM (DOUBLE ACTING PISTON ACTUATOR WITH SMART POSITIONER)

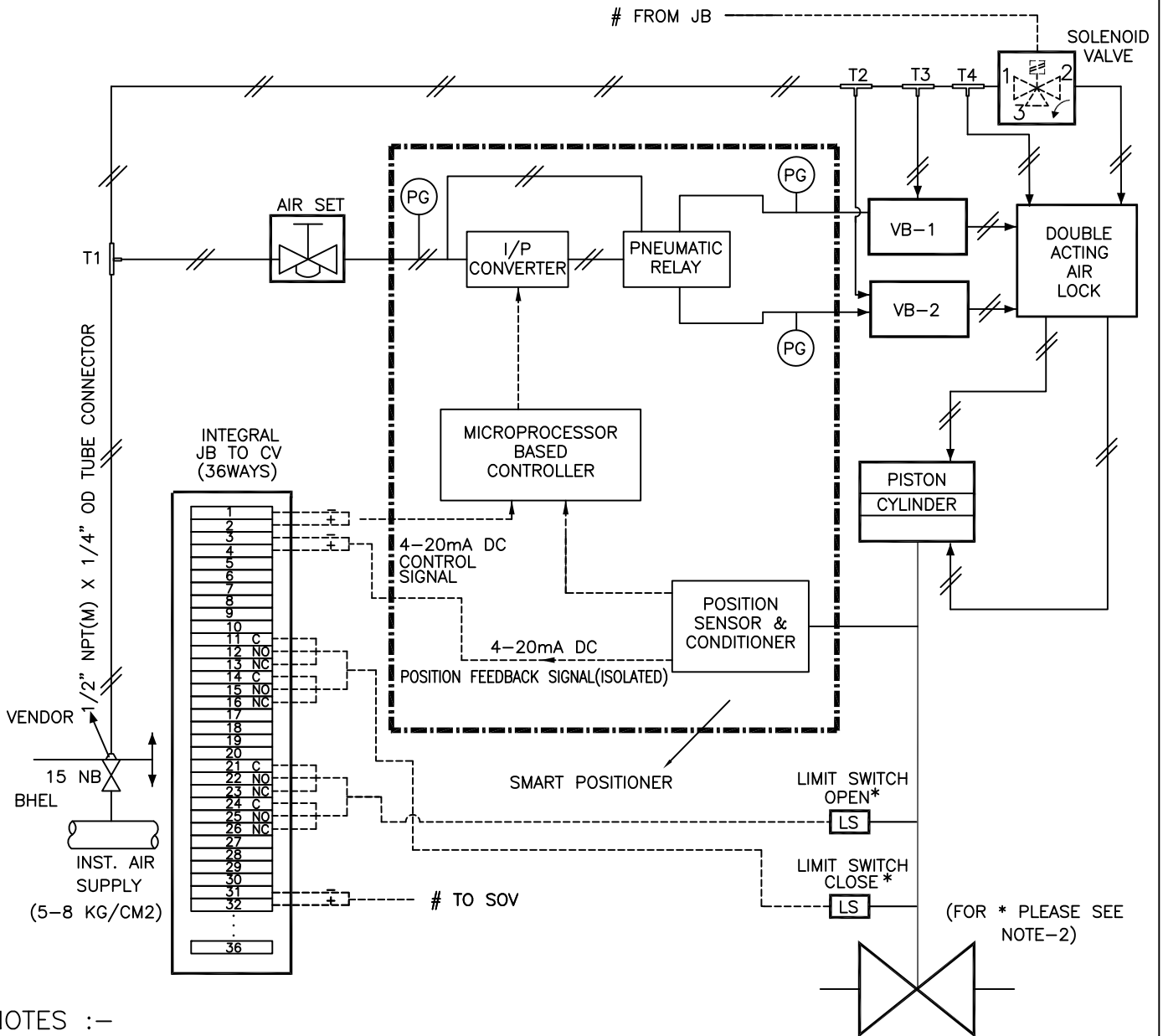

NOTES :-

1. POSITION OF EACH VALVE ON SUPPLY AIR FAILURE / ELECTRICAL SIGNAL FAILURE SHALL BE AS PER SPECIFICATION / DATA SHEET. AIR LOCK SHALL BE PROVIDED ACCORDINGLY.
2. SOLENOID VALVE & LIMIT SWITCHES WILL BE PROVIDED ONLY FOR CONTROL VALVES IF INDICATED IN RESPECTIVE DATA SHEETS.
3. SOLENOID VALVES PORTS CONDITION:
PORT 1 AND 2 SHALL BE CONNECTED UNDER DE-ENERGISED CONDITION.
PORT 2 AND 3 SHALL BE CONNECTED UNDER ENERGISED CONDITION.
4. PRESSURE GAUGES REQUIRED FOR AIR SUPPLY & OUTPUT(S).
5. MOUNTING ACCESSORIES AS REQUIRED.
6. POSITION FEEDBACK SIGNAL SHALL BE 2 WIRE 4-20mA ISOLATED SIGNAL.
7. JB TERMINALS SHALL BE CAGE CLAMP TYPE SUITABLE FOR 2.5 SQ. MM COPPER WIRE. EXTERNAL CONNECTION, OF PLUG IN TYPE OR THROUGH CABLE GLAND, SHALL BE AS PER DATA SHEET
8. ALL APPLICABLE ACCESSORIES SHALL BE PROVIDED AS INDICATED IN THE INDIVIDUAL CONTROL VALVE DATA SHEET / ACCESSORIES DATA SHEET.
9. 12 METERS 1/4" SS TUBING (AS PER ACCESSORIES DATA SHEET) & 1 SET OF FITTINGS TO BE SUPPLIED FOR EACH CONTROL VALVE FOR CONNECTION TO ISO VLV AT INST AIR HEADER ON ONE END AND TO AIR LOCK RELAY/AIR FILTER REGULATOR ON THE OTHER END. ALL THE BRASS / SS FITTINGS SHALL BE DOUBLE COMPRESSION TYPE.
10. VOLUME BOOSTER (ALONG WITH TEE-T2 AND RELATED TUBING & CONNECTORS) SHALL BE PROVIDED IF REQUIRED. AIR CONNECTION TO VOLUME BOOSTER FROM TEE-T2 & TEE-T3 SHALL BE PROVIDED.





TECHNICAL SPECIFICATION & DATA SHEET FOR CONTROL VALVE WITH ACCESSORIES (PNEUMATICALLY OPERATED)

Specification No.: PE-TS-497-145-H104

Rev. No. 00

Date :04.10.23

PAINTING SPECIFICATION

Package	Condition	Surface Preparation	Primer Coat	No. of Coats	DFT (in Microns)	Intermediate Coat (in Microns)	No. of Coats	DFT (in Microns)	Final Coat	No. of Coats	DFT (in Microns)	Total DFT (Min)
Control Valve	F91,WC9,WCB valves (above 60 deg C)	Sa 2.5	Heat Resistant Aluminium Paint IS 13183, Grade I/II	1	20	NA	NA	NA	Heat Resistant Aluminium Paint IS 13183, Grade I/II	1	20	40
	Carbon Steel Actuators and F91,WC9,WCB valves (upto 60 deg C #)	Sa 2.5	Epoxy Based Zinc Primer (92% Zinc in dry film (min), % VS = 35 (min))	1	30	Epoxy based MIO pigmented intermediate coat	1	75	Epoxy based Finish paint to IS14209 / Aliphatic acrylic Polyurethane paint to IS 13213	2	30	165

NOTES:

Stainless Steel, Non- Ferrous and Galvanised item/portion will not be painted

- For Cast/forged valves upto & including design temperature 60Deg.C, Aluminium painting as per IS-13183 Gr-3 or better with total DFT 40Micron is also acceptable

DFT shown is minimum. Bidder may offer higher paint thickness

	TECHNICAL SPECIFICATION & DATA SHEET FOR CONTROL VALVE WITH ACCESSORIES (PNEUMATICALLY OPERATED)	Specification No.: PE-TS-497-145-H104
		Rev. No. 00
		Date :04.10.23
PACKING SPECIFICATION		
<p>The item with all accessories needs to be suitably packed to avoid physical damage and corrosion during transit and storage. The packing shall be suitable for different handing operation and for the adverse condition during transportation and during indoor/outdoor storage of material. The following are the minimum requirements to be complied with for packing.</p>		
<p>Type of Packing: Item shall be fully covered with multi layered cross laminated colourless polyethylene sheet of at least 100 GSM and shall be packed inside wooden box. Sufficient amount of silica gel also to be placed inside polyethylene sheet. Item shall be firmly fixed to the bottom of the packing box to restrict movement. The electronic items like positioner and other delicate items like pressure gauges etc. shall be individually wrapped in polyethylene air bubble film or black foam. End openings are to be protected with plastic caps. Corrosion inhibitors are to be applied on all unpainted carbon steel surfaces.</p>		
<p>Quality of wood: Wood used for packing box shall be Pinewood, Rubber wood, Mango wood, Fir wood, Silver Oak wood or other as per availability with moisture content not exceeding 30%.</p>		
<p>Cushioning material and moisture absorber: Suitable cushioning shall be provided by rubberized coir/ thermocol / expanded soft polyethylene foam. Adequate quantity of silica gel packed in thin muslin cloth cotton bags should be suitably placed inside the packing box.</p>		
<p>Packing slip & holder: Packing slip kept in polyethylene bag shall be placed inside the wooden box at appropriate place. One copy of packing slip wrapped in polyethylene bag covered in galvanized iron tin sheet/ aluminium packing slip holder shall be fixed on the external surface the packing box.</p>		



COMPLIANCE CERTIFICATE

We shall comply with the following: -

1. All the requirements as stated in Technical Specification / Specific Technical requirement / Data sheets / Drawings, BHEL quality plan etc. as enclosed in the tender, shall be fully complied **without any deviation**.
2. BHEL Quality Plan (enclosed with the specification) duly signed and stamped is submitted herewith **without any deviation**.
3. Calculation of CV, Noise level, Valve outlet velocity, Trim exit velocity, Actuator sizing, Data Sheet-C in line with Data sheet-A of specification, dimensional drawings / edge preparation details, etc shall be submitted for BHEL/Customer review and approval, to reach BHEL within 15 days after receipt of LOI.
4. Selection of valves and Actuators are our (bidder's) responsibility. Any change in selection of type of valve and Actuators / Sizing / percentage opening, calculations, QP, etc., if desired by BHEL / Customer during approval of the documents after award of contract, without major changes in process parameters as per tender Specification, shall be carried out without any commercial implication and time delay.
5. Body material and Trim material combinations offered will be equivalent or better than the material specified in data Sheet-A. Wherever Trim material combinations offered differ from the specification, its superiority shall be authenticated with documentary evidence and justification produced for BHEL / Customer's concurrence. BHEL / Customer reserves the right to accept/rejects any variation to the specification.
6. Instruments / equipment offered for this package shall have at least one year's satisfactory operation in one power station having unit rating of 200 MW or above.

(To be Signed & Stamped by the Bidder)

Signature with date	
Name	
Company seal	

	TECHNICAL SPECIFICATION & DATA SHEET FOR CONTROL VALVE WITH ACCESSORIES (PNEUMATICALLY OPERATED)	Specification No.: PE-TS-497-145-H104
		Rev. No. 00
		Date : 04.10.2023
DOCUMENTATION REQUIREMENT		
DRAWINGS & DOCUMENTS TO BE SUBMITTED ALONG WITH THE BID		
1	BIDDER TO SUBMIT THE DOCUMENTS AS PER CLAUSE MENTIONED IN NIT.	

DRAWINGS & DOCUMENTS TO BE SUBMITTED AFTER AWARD OF CONTRACT	
Sl. No.	DOCUMENT TITLE
1	DATA SHEET, CALCULATION, BOQ/BOM, GA DRAWING, EDGE Preparation details & HOOK UP /INSTALLATION DRAWING for Control Valves
2	QAP for Control Valves
3	CALIBRATION REPORTS
DRAWINGS & DOCUMENTS TO BE SUBMITTED AS FINAL/AS-BUILT DOCUMENT	
Sl. No.	DOCUMENT TITLE
1	DATA SHEET, CALCULATION, BOQ/BOM, GA DRAWING, EDGE Preparation details & HOOK UP /INSTALLATION DRAWING for Control Valves
2	APPROVED QUALITY PLAN
3	CALIBRATION REPORTS
4	CATALOGUE/TECHNICAL LITERATURE/O&M MANUAL
5	ALL TEST CERTIFICATES

	TECHNICAL SPECIFICATION & DATA SHEET FOR CONTROL VALVE WITH ACCESSORIES (PNEUMATICALLY OPERATED)	Specification No.: PE-TS-497-145-H104			
		Rev. No. 00			
		Date :04.10.23			
SPECIFICATION & DATA SHEET FOR CONTROL VALVE					
A. GENERAL INFORMATION					
1	TAG NUMBER / SERVICE				
2	LOCATION / DUTY				
B. DESIGN CODES & STANDARDS					
3	CODE / STANDARD	REFER GENERAL NOTES			
C. TECHNICAL PARAMETERS / DESIGN FEATURES					
4	PIPE SIZE (OD X THK) mm				
5	PIPE MATERIAL INLET / OUTLET				
6	VALVE BODY TYPE / MATERIAL / MINIMUM SIZE OF VALVE				
7	GUIDING / NO. OF PORTS / TRIM FORM				
8	CAGE TYPE / CAGE MATERIAL / GUIDE BUSH				
9	MATERIAL: PLUG / STEM / SEAT / YOKE				
10	PACKING MATERIAL / NOS / TYPE				
11	END CONNECTION / ANSI RATING / BONNET TYPE				
12	VALVE OUTLET VELOCITY				
13	LEAKAGE CLASS / NOISE LEVEL (dBA)				
14	VACUUM SERVICE / ANTI CAVITATION TRIM				
15	ACTUATOR TYPE				
16	TRAVEL TIME FOR OPEN TO CLOSE, CLOSE TO OPEN				
17	VALVE POSN. ON: ELECTRICAL SIGNAL FAILURE / SUPPLY AIR FAILURE				
18	EXPANDER / REDUCER BET CV AND PROCESS PIPE				
19	EXPANDER / REDUCER BET CV AND CARTRIDGE(IF CARTRIDGE IS APPLICABLE)				
20	SMART POSITIONER / POSITION LIMIT SWITCH				
21	POSITION TRANSMITTER / E/P CONVERTER				
22	AIR FILTER REGULATOR / AIR LOCK RELAY				
23	SOLENOID VALVE / JUNCTION BOX				
24	HAND WHEEL (SIDE MOUNTED) / LOCAL POSITIONER INDICATOR				
25	SERVICE CONDITIONS				
26	CASE-1				
27	CASE-2				
28	CASE-3				
29	CASE-4				
30	CASE-5				
31	MAX SHUT OFF PRESSURE,BODY DESIGN PRESSURE (KG/CM2 (g) ,TEMP (DEG C)				
32	IBR FORM-IIC				
33	PROCESS CONDITION				
D. GUARENTEED PERFORMANCE REQUIREMENTS					
34	LINEARITY / HYSTERISIS / SENSITIVITY / OVERALL ACCURACY				
35	MODEL OF CONTROL VALVE	BIDDER TO FURNISH			
36	SIZE OF CONTROL VALVE	BIDDER TO FURNISH			

Project	2x660 MW NTPC TALCHER TPP STAGE-III
Package	Non Critical Control Valves
Subject	Annexure-I

Sl. No.	TERMS & CONDITIONS																																																					
1.	Delivery Terms	<p>a. Main Supply including quantity variation: Delivery completion for Main supply shall be 260 days from the PO date for Unit#1 and 350 Days from the P.O date for Unit#2.</p> <p>Primary drawings / documents as per Technical Specification No. of Specification No.: PE-TS-497-145-IH04 Rev. No. 00 Dated 04.10.2023 shall be considered for delivery and their submission / re-submission schedule shall be as follows: -</p> <table border="1"> <thead> <tr> <th>1st</th> <th>1st</th> <th>2nd</th> <th>2nd</th> <th></th> <th></th> <th></th> <th></th> <th></th> <th></th> <th></th> </tr> <tr> <th>Vendor Sub</th> <th>BHEL comment</th> <th>Vendor Sub</th> <th>BHEL and Customer comment/ approval (3 Days for BHEL and 15 days for customer)</th> <th>Total Engg Time</th> <th>Manufacturing +Inspection+ MDCC Time (Single Unit supplies)</th> <th>Main Supply Delivery days from PO</th> <th>Del time for Unit 2 Main supply BOQ from PO date (If applicable)</th> <th>Mandatory Spares from BHEL clearance date</th> <th>Validity of contract for main supply including of subsequent units (if applicable)</th> <th>Engg Remarks</th> </tr> </thead> <tbody> <tr> <td></td> <td></td> <td></td> <td></td> <td></td> <td></td> <td>"A" Days</td> <td></td> <td></td> <td>"C" Days</td> <td></td> </tr> <tr> <td>15</td> <td>10</td> <td>7</td> <td>18</td> <td>50</td> <td>210</td> <td>260</td> <td>350</td> <td>150</td> <td>365</td> <td>considering CV test - one per type/size</td> </tr> </tbody> </table> <p>Mandatory Spares:150 days from BHEL clearance.</p> <p>Notes:</p> <p>a. Supplier to start manufacturing/supply only after getting the applicable engineering Drgs. /docs approved from BHEL/End Customer.</p> <p>b. Drawings /documents submission/re-submission schedule shall be as indicated in technical specification which shall be used for progress monitoring purpose and required course correction, if any.</p> <p>c. The delivery date specified is for completion of the deliveries. Deliveries to start progressively so as to meet the completion schedule.</p> <p>d. The delivery conditions specified are for contractual purposes. However, to meet project requirement, BHEL may ask for early deliveries without any compensation thereof.</p>									1st	1st	2nd	2nd								Vendor Sub	BHEL comment	Vendor Sub	BHEL and Customer comment/ approval (3 Days for BHEL and 15 days for customer)	Total Engg Time	Manufacturing +Inspection+ MDCC Time (Single Unit supplies)	Main Supply Delivery days from PO	Del time for Unit 2 Main supply BOQ from PO date (If applicable)	Mandatory Spares from BHEL clearance date	Validity of contract for main supply including of subsequent units (if applicable)	Engg Remarks							"A" Days			"C" Days		15	10	7	18	50	210	260	350	150	365	considering CV test - one per type/size
1st	1st	2nd	2nd																																																			
Vendor Sub	BHEL comment	Vendor Sub	BHEL and Customer comment/ approval (3 Days for BHEL and 15 days for customer)	Total Engg Time	Manufacturing +Inspection+ MDCC Time (Single Unit supplies)	Main Supply Delivery days from PO	Del time for Unit 2 Main supply BOQ from PO date (If applicable)	Mandatory Spares from BHEL clearance date	Validity of contract for main supply including of subsequent units (if applicable)	Engg Remarks																																												
						"A" Days			"C" Days																																													
15	10	7	18	50	210	260	350	150	365	considering CV test - one per type/size																																												

Project	2x660 MW NTPC TALCHER TPP STAGE-III
Package	Non Critical Control Valves
Subject	Annexure-I

2.	Validity of contract (PO rates, terms and conditions)	<p>Vendor has to make supply of goods/services as per the delivery time mentioned above. However, due to unavoidable circumstances if delay happens in providing inputs/ clearances (inputs, Engineering approvals, deputing inspector for inspection, issuance of MDCC and any hold imposed owing to site issues etc.) for which delivery time extension is admissible as per point no.3, in such situation it shall be obligatory at vendor part to execute the contract at PO rates, terms and conditions where inputs/ clearances has been accorded within validity of contract. Validity period for various activities shall be as defined below or as mentioned in the NIT.</p> <p>2.1. Validity of the contract for main supply including quantity variation.</p> <ul style="list-style-type: none"> Contract shall be valid for 365 days from the PO date. However, delay at vendor's end (if any) shall be added to the validity period and contract validity shall get extended by the delay period at vendor's end. <p>For example: Original Delivery period for main supply: A (in days) Delay at vendor's end: B (in days beyond "A" days) Contract validity: C+B (in days)</p> <p>2.2. Validity of the contract for supply of mandatory spares applicable in the contract:</p> <ul style="list-style-type: none"> Validity of contract for supply of mandatory spares/ Electrolyte/BHMS/ services applicable in the contract shall be one year over and above contractual validity period for main supply including quantity variation as specified at point no. 2.1 above. <p>Notes:</p> <ol style="list-style-type: none"> B is the Vendor delay days beyond original contractual delivery period for main supply /extended delivery period owing to time taken by BHEL. Main supply, applicable in the contract released/ cleared for manufacturing within contractual validity period, to be supplied by vendor/supplier at PO rates, terms and conditions. Execution of the contract quantities released beyond contract validity period shall be decided on mutual consent basis at PO rates, terms and conditions.
3.	Delivery Extension: Extension of contractual delivery time	<p>Delivery time mentioned in the NIT includes Engineering completion time (time for drawing/document submission/resubmission by the vendor and review/approval of the same by the BHEL/End customer), manufacturing, inspection, Packing and dispatch time. Due diligence is to be observed by the vendor to ensure timely completion of engineering and supply.</p> <p>During the execution of the contract, time loss occurred owing to the reason attributable to BHEL besides force majeure shall be considered for delivery time extension to the vendor as given below:</p> <ol style="list-style-type: none"> Any Delay in providing comments/ approval on Primary drawing/documents beyond the stipulated time as specified in NIT. Time Loss in approval of the drawing/document as a result of increase in the iteration not attributable to the vendor (i.e. resubmission owing to end customer comments) as certified by BHEL. Time extension equivalent to the resubmission time noted in the Tech. spec/NIT and consequential increase in the approval time in lieu of increase in iteration shall be applicable. However, for incomplete re- submission time loss shall be in vendor account. Delay in providing engineering input/material by BHEL.

Project	2x660 MW NTPC TALCHER TPP STAGE-III
Package	Non Critical Control Valves
Subject	Annexure-I

		<p>iv. Delay in deputing inspector for inspection and delay in release of MDCC in line with GEM ATC terms.</p> <p>v. Any hold put by BHEL for whatever reasons during execution of contract (within contract validity period), time extension equivalent to hold period shall be admissible. However, in the event hold period continues for more than 30 days then, an additional fifteen days for the purposes of mobilization and demobilization of resources shall also be admissible.</p> <p>Note: Extension in delivery period if any with or without imposition of LD shall be considered after detailed delay analysis based on provisions given above. However, no delay analysis will be applicable if supply is completed within delivery schedule as specified in Purchase order.</p>
4.	BID SECURITY/ Earnest Money Deposit (EMD)	<p>EMD is applicable. EMD amount shall be Rs. 2.5 Lakh.</p> <p>EMD is to be submitted by the all bidders along with their bids (except Bidders Exempted as Per Cl. No. 4.XIII (M) of General Terms and Conditions on GeM 4.0 (Version 1.12) dt 16th August 2023)</p> <p>Modes of deposit: -</p> <p>The EMD may be accepted only in the following forms:</p> <p>i) Electronic Fund Transfer credited in BHEL account (before tender opening)</p> <p style="padding-left: 40px;">BHEL-PEM account details are as follows:</p> <p style="padding-left: 40px;">Bank name, State Bank of India Account No: 39922687394 IFSC: SBIN0017313 BRANCH-CAG II NEW DELHI</p> <p>ii) Banker's cheque/ Pay order/ Demand draft, in favour of BHEL-PEM, Noida (along with the offer).</p> <p>iii) Fixed Deposit Receipt (FDR)</p> <p>iv) Bank Guarantee from any of the Scheduled Banks.</p> <p>v) Insurance Surety Bonds.</p> <p>The EMD shall remain valid for a period of 45 (forty-five) days beyond the final bid validity period.</p> <p>Forfeiture of EMD</p> <p>I. A bidder's EMD will be forfeited if the bidder withdraws or amends its/his tender or impairs or derogates from the tender in any respect within the period of validity of the tender or if the successful bidder fails to furnish the required performance security within the specified period mentioned in the Tender.</p> <p>II. EMD by the tenderer to be withheld in case any action on the bidder is envisaged under the provisions of extant "Guidelines on Suspension of business dealings with suppliers/ contractors (abridged version of guidelines is available on www.bhel.com)" and forfeited/ released based on the action as determined under these guidelines.</p> <p>I. Bid securities of the unsuccessful bidders shall be returned to them after expiry of the final bid validity period and latest by the 30th day after the award of the contract. However, Bid securities of unsuccessful bidders during first stage i.e. technical-commercial evaluation etc. shall be returned within 30 days of declaration of result of first stage i.e. technical-commercial evaluation.</p> <p>II. Bid security shall be refunded to the successful bidder on conclusion of the order/ receipt of a performance security.</p> <p>III. EMD shall not carry any interest</p>

Project	2x660 MW NTPC TALCHER TPP STAGE-III
Package	Non Critical Control Valves
Subject	Annexure-I

5.	Performance Security	<p>I. Initially 10% of the contract value (total order value in case of GeM POs excluding PVC/total Ex-works price in case of outside GeM POs excluding PVC). However, 5% of the contract value (as above) will be released after completion of Main Supply based on certification by Project Group.</p> <p style="text-align: center;">OR</p> <p>II. 5% of the contract value (total order value in case of GeM POs excluding PVC/total Ex-works price in case of outside GeM POs excluding PVC). Additional 5% of the contract value will be retained from first bill & subsequent bill(s) of the same contract. The retention amount will be released after completion of Main Supply based on certification by Project Group.</p> <p>III. Initial validity of performance security shall be 32 months from PO date (Considering delivery period of 12 months (350 days delivery of U#2) + 18 months guarantee period + 2 months claim period is already mentioned in GTC cl no. 7.ii GeM 3.0). Further, extension if any shall be as per GeM Terms.</p> <p>Modes of deposit:</p> <p>Performance security may be furnished in the following forms:</p> <ol style="list-style-type: none"> a) Local cheques of Scheduled Banks (subject to realization)/ Pay Order/ Demand Draft/ Electronic Fund Transfer in favour of BHEL. b) Bank Guarantee from Scheduled Banks / Public Financial Institutions as defined in the Companies Act. The Bank Guarantee format should have the approval of BHEL. c) Fixed Deposit Receipt issued by Scheduled Banks / Public Financial Institutions as defined in the Companies Act (FDR should be in the name of the Contractor, a/c BHEL). d) Securities available from Indian Post offices such as National Savings Certificates, Kisan Vikas Patras etc. (held in the name of Contractor furnishing the security and duly endorsed/ hypothecated/ pledged, as applicable, in favour of BHEL). e) Insurance Surety Bond. (Note: BHEL will not be liable or responsible in any manner for the collection of interest or renewal of the documents or in any other matter connected therewith) <p>Performance Security is to be furnished within 14 days from the date of PO/LOA and it should remain valid for a period of 60 (sixty) days beyond the date of completion of all contractual obligations of the supplier, including warranty obligations.</p> <p>Forfeiture of Performance Security:</p> <ol style="list-style-type: none"> a) The performance security will be forfeited and credited to BHEL's account in the event of a breach of contract by the supplier. b) PS should be refunded to the contractor without interest, after he duly performs and completes the contract in all respects but not later than 60(sixty) days of completion of all such obligations including the warranty under the contract. c) The Performance Security shall not carry any interest.
6.	Breach of contract, Remedies and Termination	<p>“In case of Breach of Contract, BHEL shall recover 10% of the contract value from the Vendor using following instruments:</p> <ol style="list-style-type: none"> (i) encashment of security instruments like EMD, Performance Security with PEM against the said contract (ii) balance amount (if value of security instruments is less than 10% of the contract value) from other financial remedies i.e. available bills of the Vendor, retention amount etc. with PEM

Project	2x660 MW NTPC TALCHER TPP STAGE-III
Package	Non Critical Control Valves
Subject	Annexure-I

	<p>(iii) balance amount from security instruments like EMD, Performance Security and other financial remedies i.e. available bills of the Vendor, retention amount etc. with other units of BHEL</p> <p>(iv) if recovery is not possible then legal remedies shall be pursued”</p> <p>The balance scope shall be got done independently without Risk & Cost of the failed supplier/ contractor. Further, levy of liquidated damages, debarment, termination, de-scoping, short-closure, etc., shall be applied as per provisions of the contract.</p>
--	---

SNO	Customer	Contract No	Type	PGMA	PGMA Des	DU	DU Des	Dispatch Qty.	Unit	BBU No.	BBU Sno	Box No.	Packing List No.	Material Required For (Set-1/ Set-2)	NS	Remarks
	NTPC	CS-4540-001A-2-FCCOA-7227	<BOI * > <*BHEL shall indicate whether item is BOI or BHEL Inhouse manufacture >	<Vendor to fill BHEL Item Code>	<Vendor to fill Package name>	BHEL PSPEM NOIDA	<Vendor to fill up Item wise description>	<Vendor to fill up dispatch quantity>	<Vendor to fill up UOM>	to fill up BBU No. provided by BHEL>	<Vendor to fill up BBU No. provided by BHEL>	<Vendor to fill up box no.>	<Vendor to fill up Packing list number>	Vendor to indicate Material is for Unit-1 or Unit-2	<Nature of Supply :- Vendor to indicate whether Item is Main supply or mandatory spares>	Remarks if any

Item Number	Item Title	Item Description	Item Quantity	Unit of Measure	Freight %age	GST %age	Remark
1	Tag No.- ASV-8	D/A Pegging from Aux. Steam Header (ASV-8)(Quantity for Unit # 1 &2)	2	Nos.			
2	Tag No.- CRHV-6	D/A Pegging from CRH Line (CRHV-6)(Quantity for Unit # 1 &2)	2	Nos.			
3	Tag No.- CDV-25	Condensate Control valve (CDV-25) (Quantity for Unit # 1 &2)	2	Nos.			
4	Tag No.- CDV-65	CEP-A Minimum Recirculation (CDV-65) (Quantity for Unit # 1 &2)	2	Nos.			
5	Tag No.- CDV-67	CEP-B Minimum Recirculation (CDV-67) (Quantity for Unit # 1 &2)	2	Nos.			
6	Tag No.- CDV-69	CEP-C Minimum Recirculation (CDV-69) (Quantity for Unit # 1 &2)	2	Nos.			
7	Tag No.- CDV-39	GSC min. flow recirculation (CDV-39) (Quantity for Unit # 1 &2)	2	Nos.			
8	Tag No.- CDV-43	Excess Dump Control (CDV-43) (Quantity for Unit # 1 &2)	2	Nos.			
9	Tag No.- CDV-72	Condensate Spray for Valve Gland Sealing AND F/T- A (CDV-72) (Quantity for Unit # 1 &2)	2	Nos.			
10	Tag No.- CDV-84	Condensate Spray for F/T-B (CDV-84) (Quantity for Unit # 1 &2)	2	Nos.			
11	Tag No.- CDV-94	CONDENSATE FOR UNIT FLASH TANK SPRAY (CDV-94) (Quantity for Unit # 1 &2)	2	Nos.			
12	Tag No.- DRV-53	HPH-9A Drain to HPH-8A (DRV-53) (Quantity for Unit # 1 &2)	2	Nos.			
13	Tag No.- DRV-59	HPH-9B Drain to HPH-8B (DRV-59) (Quantity for Unit # 1 &2)	2	Nos.			
14	Tag No.- DRV-56	HPH-9A ALT. DRAIN TO F/T (DRV-56) (Quantity for Unit # 1 &2)	2	Nos.			
15	Tag No.- DRV-62	HPH-9B ALT. DRAIN TO F/T (DRV-62) (Quantity for Unit # 1 &2)	2	Nos.			
16	Tag No.- DRV-2	HPH-8A Drain to HPH-7A (DRV-2) (Quantity for Unit # 1 &2)	2	Nos.			
17	Tag No.- DRV-8	HPH-8B Drain to HPH-7B (DRV-8) (Quantity for Unit # 1 &2)	2	Nos.			
18	Tag No.- DRV-5	HPH-8A ALT. DRAIN TO F/T (DRV-5) (Quantity for Unit # 1 &2)	2	Nos.			
19	Tag No.- DRV-11	HPH-8B ALT. DRAIN TO F/T (DRV-11) (Quantity for Unit # 1 &2)	2	Nos.			
20	Tag No.- DRV-15	HPH-7A NORMAL DRAIN TO DEAERATOR (DRV- 15) (Quantity for Unit # 1 &2)	2	Nos.			
21	Tag No.- DRV-22	HPH-7B NORMAL DRAIN TO DEAERATOR (DRV- 22) (Quantity for Unit # 1 &2)	2	Nos.			
22	Tag No.- DRV-18	HPH-7A ALT. DRAIN TO F/T (DRV-18) (Quantity for Unit # 1 &2)	2	Nos.			
23	Tag No.- DRV-25	HPH-7B ALT. DRAIN TO F/T (DRV-25) (Quantity for Unit # 1 &2)	2	Nos.			
24	Tag No.- DRV-77	LPH-3 DRAIN D/S OF DRIP PUMP (DRV-77) (Quantity for Unit # 1 &2)	2	Nos.			
25	Tag No.- DRV-31	LPH-3 ALT. DRAIN TO F/T (DRV-31) (Quantity for Unit # 1 &2)	2	Nos.			
26	Tag No.- DRV-48	DEAERATOR OVERFLOW TO F/T (DRV-48) (Quantity for Unit # 1 &2)	2	Nos.			
27	Tag No.- DRV-65	LPH-4 Drain to LPH-3 (DRV-65) (Quantity for Unit # 1 &2)	2	Nos.			
28	Tag No.- DRV-68	LPH-4 Drain to F/T (DRV-68) (Quantity for Unit # 1 &2)	2	Nos.			
29	Tag No.- DRV-82	LPH-5 Drain to LPH-4 (DRV-82) (Quantity for Unit # 1 &2)	2	Nos.			
30	Tag No.- DRV-85	LPH-5 Drain to F/T (DRV-85) (Quantity for Unit # 1 &2)	2	Nos.			
31	Tag No.- DMV-43	NORMAL DM MU TO HOTWELL (DMV-43) (Quantity for Unit # 1 &2)	2	Nos.			

Item Number	Item Title	Item Description	Item Quantity	Unit of Measure	Freight %age	GST %age	Remark
32	Tag No.- DMV-78	EMERGENCY DM MU TO HOTWELL (DMV-78) (Quantity for Unit # 1 &2)	2	Nos.			
33	Tag No.- PGC36AA101	DMCW SYSYTEM FOR SG AUX'S (Quantity for Unit # 1 &2)	2	Nos.			
34	Tag No.- PGC15AA101	DMCW SYSYTEM FOR TG AUX'S (Quantity for Unit # 1 &2)	2	Nos.			
2	1,4 inch SS TUBING- 12 METER FOR EACH TAG	1,4 inch SS TUBING- 12 METER FOR EACH TAG (Quantity for Unit-I and Unit-II)	816	METER			
3	SS FITTINGS for connection to Air Filter Regulator- FOR EACH TAG	SS FITTINGS for connection to Air Filter Regulator- FOR EACH TAG (Quantity for Unit-I and Unit-II)	2	LOT			
4	SS FITTINGS for connection to Air Lock Relay- FOR EACH TAG	SS FITTINGS for connection to Air Lock Relay- FOR EACH TAG (Quantity for Unit-I and Unit-II)	2	LOT			
5	SS FITTINGS for connection to IA Header Isolation Valve - FOR EACH TAG	SS FITTINGS for connection to IA Header Isolation Valve - FOR EACH TAG (Quantity for Unit-I and Unit-II)	2	LOT			
6	SS EQUAL TEE - FOR EACH TAG	SS EQUAL TEE - FOR EACH TAG (Quantity for Unit-I and Unit-II)	2	LOT			
7	SS 1,2 inch NPT M X 1,4 inch OD TUBE CONNECTOR- FOR EACH TAG	SS 1,2 inch NPT(M) X 1/4 inch OD TUBE CONNECTOR- FOR EACH TAG (Quantity for Unit-I and Unit-II)	2	LOT			
8	CV TEST CHARGES FOR EACH CONTROL VALVE	CV TEST CHARGES FOR EACH CONTROL VALVE (For Unit-I and Unit-II)	1	LOT			
9	VALVE DIAGNOSTIC AND CONFIGURATION SOFTWARE- FOR ALL TAGS	VALVE DIAGNOSTIC AND CONFIGURATION SOFTWARE (FOR ALL TAGS) (Quantity for Unit-I and Unit-II)	1	LOT			
10	Gaskets-Commissioning spares	(Quantity for Station) One(1) set with each control valve tag 1 Lot is equal to 1 set with each control valve tag (Quantity for Unit # 1 &2)	1	LOT			
11	Gland Packing- Commissioning spares	(Quantity for Station) One(1) set with each control valve tag 1 Lot is equal to 1 set with each control valve tag (Quantity for Unit # 1 &2)	1	LOT			
12	MANDATORY SPARES-FDV14-CRITICAL CONTROL VALVE - Pneumatic and electro-hydraulic actuator assembly	Quantity for Station-1 no. of each type,model and rating 1 Lot is equal to 1 no. of each type,model and rating (Quantity for Unit # 1 &2)	1	LOT			
13	MANDATORY SPARES-FDV14-CRITICAL CONTROL VALVE - Diaphragms, O rings, seals etc. of all types make etc.	Quantity for Station-5 nos. of all types make etc. 1 Lot is equal to 5 nos. of all types make etc (Quantity for Unit # 1 &2)	1	LOT			
14	MANDATORY SPARES-FDV14-CRITICAL CONTROL VALVE - Solenoid valves If applicable	Quantity for Station-2 nos. each type 1 Lot is equal to 2 nos. each type (Quantity for Unit # 1 &2)	1	LOT			

Item Number	Item Title	Item Description	Item Quantity	Unit of Measure	Freight %age	GST %age	Remark
15	MANDATORY SPARES-FDV14-CRITICAL CONTROL VALVE-Smart positioner complete unit and accessories link assembly	Quantity for Station2 no. of each type, model and rating 1 Lot is equal to 2 no. of each type, model and rating (Quantity for Unit # 1 &2)	1	LOT			
16	MANDATORY SPARES-FDV14-CRITICAL CONTROL VALVE - Pneumatic air-filter-Regulator of each type,Make rating etc.	Quantity for Station-2 nos of each type, make, rating etc. 1 Lot is equal to 2 nos of each type, make, rating etc (Quantity for Unit # 1 &2)	1	LOT			
17	MANDATORY SPARES-FDV14-CRITICAL CONTROL VALVE - Air lock relays	Quantity for Station-2 nos. of each type 1 Lot is equal to 2 nos. of each type (Quantity for Unit # 1 &2)	1	LOT			
18	Additional Requirement of spares for SG DMCW valve- Valve trim -including cage, plug, stem, seat rings, guide bushings, gland packing, gaskets etc.	1 set for each type of control valve. 5 Sets each for gland packing and gaskets for all control valves. 1 Lot is equal to 1 set for each type of control valve and 5 Sets each for gland packing and gaskets for all control valves. (Quantity for Unit # 1 &2)	1	LOT			
19	Additional Requirement of spares for CEP min recirculation valve -	CEP recirculation valve trim which includes spindle with cone, seat ring, guide bush, cage-1 Set 1 Lot equal to 1 Set (Quantity for Unit # 1 &2)	1	LOT			
20	Additional Requirement of spares for CEP min recirculation valve -	CEP recirculation valve soft parts i.e. gland packing, seals, O-rings, gaskets etc.-3 Set 1 Lot equal to 3 set (Quantity for Unit # 1 &2)	1	LOT			

Note:

1. Wherever the quantities have been indicated for each type, size, thickness, material, radius, range etc., these shall cover all the items supplied and installed and the breakup for these shall be furnished in the bid. In case spares indicated in the list are not applicable to the particular design offered by the bidder, the bidder should offer spares applicable to offered design with quantities generally in line with the approach followed in the above list.