

NTPL
2X500MW TUTICORIN FGD TPS

**TECHNICAL SPECIFICATION
FOR
*220V DC BATTERY CHARGER***

SPECIFICATION NO: PE-TS-483-508-E002, R0



BHARAT HEAVY ELECTRICALS LIMITED
POWER SECTOR
PROJECT ENGINEERING MANAGEMENT
NOIDA, UP (INDIA) – 201301

	TECHNICAL SPECIFICATION FOR 220V DC BATTERY CHARGER	SPECIFICATION NO. PE-TS-483-508-E002	
		VOLUME II	
		SECTION I	
		REVISION 00	DATE: 28.03.2022
		Sheet 1 of 1	

CONTENTS

<u>S. NO.</u>	<u>DESCRIPTION</u>	<u>NO. OF SHEETS</u>
1.0	SECTION – I	
	COMPLIANCE SHEET	01
	SPECIFIC TECHNICAL REQUIREMENT	18
	DATA SHEET - A	03
	DATA SHEET - C	03
2.0	SECTION- 'II'	
	STANDARD TECHNICAL REQUIREMENTS	15
	ANNEXURE-I LIST OF APPLICABLE STANDARDS	01
	ANNEXURE-II LOAD DUTY CYCLE FOR 220V DC SYSTEM	01
	ANNEXURE-III SUB VENDOR LIST FOR CHARGER	14
	QUALITY PLAN	09

TOTAL SHEETS INCLUDING COVER SHEET/CONTENT SHEET = 66

	TECHNICAL SPECIFICATION FOR 220V DC BATTERY CHARGER	SPECIFICATION NO. PE-TS-483-508-E002	
		VOLUME II	
		SECTION I	
		REVISION 00	DATE: 28.03.2022
		Sheet 1 of 1	

COMPLIANCE CERTIFICATE

The bidder shall confirm compliance to the following by signing/ stamping this compliance certificate and furnishing same with the offer.

1. The scope of supply, technical details, construction features, design parameters etc. shall be as per technical specification & there are no exclusion/ deviation with regard to same
2. There are no deviation with respect to specification other than those furnished in the 'schedule of deviations'
3. Only those technical submittals which are specifically asked for in NIT to be submitted at tender stage shall be considered as part of offer. Any other submission, even if made, shall not be considered as part of offer.
4. Any comments/ clarifications on technical/ inspection requirements furnished as part of bidder's covering letter shall not be considered by BHEL, and bidder's offer shall be construed to be in conformance with the specification.
5. Any changes made by the bidder in the price schedule with respect to the description/ quantities from those given in 'BOQ-Cum-Price schedule' of the specification shall not be considered (i.e., technical description & quantities as per the specification shall prevail).

BIDDER'S STAMP & SIGNATURE



**TECHNICAL SPECIFICATION FOR
220V DC BATTERY CHARGER**

2 X 500 MW TUTICORIN FGD TPS

SPECIFICATION NO. PE-TS-483-508-E002

VOLUME II B

SECTION -I

REVISION 0 | DATE 28.03.2022

SHEET 1 OF 18

SECTION – I

SPECIFIC TECHNICAL REQUIREMENTS



TECHNICAL SPECIFICATION FOR 220V DC BATTERY CHARGER

2 X 500 MW TUTICORIN FGD TPS

SPECIFICATION NO. PE-TS-483-508-E002

VOLUME II B

SECTION -I

REVISION 0 | DATE 28.03.2022

SHEET 2 OF 18

1.0 SCOPE OF ENQUIRY

- 1.1 This specification covers the design, manufacture, assembly, testing and inspection at vendor's/sub-vendor's works, packing and despatch to site, Supervision of commissioning & testing of 220V DC battery charger as described in the various sections of this specification. The equipment shall generally conform to IS. In this specification though erection and commissioning is not included in vendor's scope, the vendor shall still not be absolved of his responsibility of establishing the correctness of equipment at site.
- 1.2 Technical requirements of 220V DC BATTERY CHARGER are indicated in Data Sheet-A, Section-I & Section-II.
- 1.3 The stipulation of Data Sheet-A shall prevail in case of any conflict between the stipulations of Data Sheet-A & Section-II.
- 1.4 The stipulation of Section-I shall prevail in case of any conflict between the stipulations of Section-I & Section-II.
- 1.5 In case of any conflict between stipulations of the same section, Stringent of the two shall prevail.

2.0 BILL OF QUANTITIES

Quantity requirements shall be as per 'BOQ-cum-price schedule' as part of NIT.

3.0 SPECIFIC TECHNICAL REQUIREMENTS

3.1 Technical /Quality/ Inspection:

S.No.	Reference clause No. of Section II (if any)	Specific Requirement/ Change
1.	Section II clause 10.9	All routine & acceptance test to be performed as per QAP NO PE-QP-999-508-E003, R01.Charges for carrying out these routine & acceptance tests are deemed to be included in the charger price.
2.	Clause 5.13 section- II: All chargers shall have AC input and DC output switches of air break, single throw, load break and fault make type.	MCCB shall be provided to receive incoming AC supply
3.	Clause 5.17 section – II: The charger panel and its frame shall be fabricated from 1.6mm & 2.0 mm cold rolled sheet respectively.	The charger panel and its frame shall be fabricated from 2.0 mm cold rolled sheet.
4.	clause 10.2 (section - II): Charges for carrying out all routine tests & type tests are deemed to be included in the charger price	Bidder shall quote for heat run test as indicated in the BOQ cum price schedule. Charges for all other type and routine tests are deemed to be included in the charger price



**TECHNICAL SPECIFICATION FOR
220V DC BATTERY CHARGER**

SPECIFICATION NO. PE-TS-483-508-E002

VOLUME II B

SECTION -I

2 X 500 MW TUTICORIN FGD TPS

REVISION 0 | DATE 28.03.2022

SHEET 3 OF 18

4.0 SYSTEM CONCEPT

4.1 FGD Plant 220V DC SYSTEM:

220V DC system shall be an ungrounded system comprising of:

a) 2x100% batteries each with associated float cum boost charger & float charger for FGD plant and 1x100% sectionalised DCDB.

The 220V DC system is designed to cater the control, protection, interlocking, emergency lighting, UPS loads for FGD plant The load duty cycle for 220V battery is enclosed as Annexure-II.

The chargers will be rated based on the following considerations:

Float Charger: The float charger shall be sized to carry the total DC continuous load and the trickle charging current of the battery plus a 25% margin. The charger shall be capable of delivering the rated load under the specified voltage and frequency variations of incoming AC supply.

FCB Charger: The float-cum-boost charger shall be sized to restore the fully discharged battery to full charge condition in eight (8) hours for lead-acid battery with 25% margin over maximum charging rate or to operate as a float charger with duty requirement as indicated under float charger above, whichever is greater.

For both the chargers, bidder to note that design margin has already been considered in charger rating mentioned in BOQ cum unpriced price schedule.

Charger configuration (single line diagram) is shown below:-



**TECHNICAL SPECIFICATION FOR
220V DC BATTERY CHARGER**

SPECIFICATION NO. PE-TS-483-508-E002

VOLUME II B

SECTION -I

2 X 500 MW TUTICORIN FGD TPS

REVISION 0 | DATE 28.03.2022

SHEET 4 OF 18

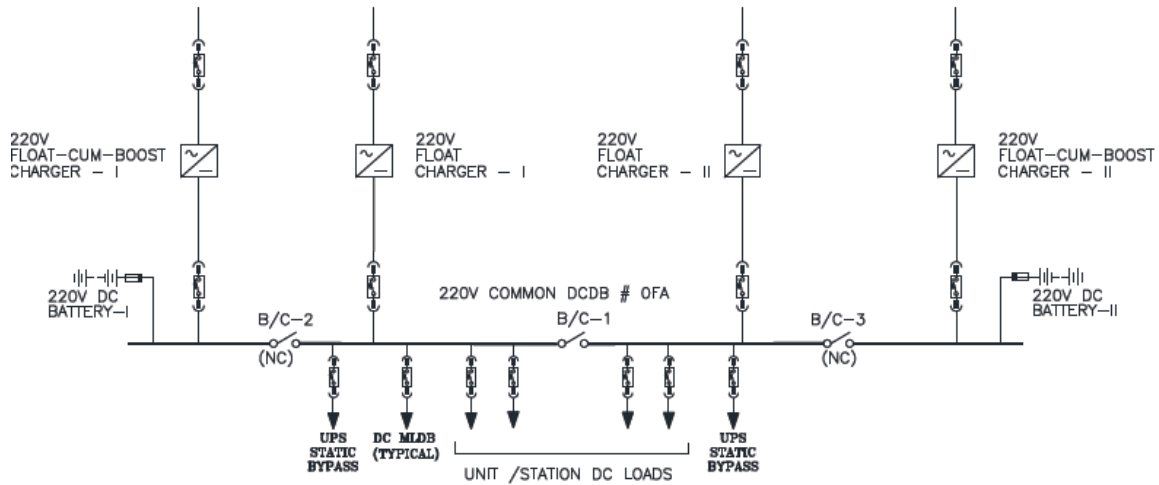

4.2 Each float cum boost charger will have a 'FLOAT/BOOST' selector switch for selection of battery charging mode. 'AUTO/MANUAL' selector switch for selection of battery charging control mode along with voltage/ current setter for Float charger and FCB charger shall be provided. The float cum boost charger shall have provision for float equalising, and boost charging the battery through manual selection.

SL.NO.	MODE OF OPERATION	OPERATION PHILOSOPHY	CONNECTED EQUIPMENT STATUS
1.	System Normal	Float charger feeds the connected DC loads while float charging the battery	B/C-1: OPEN B/C-2: CLOSED B/C-3: CLOSED FC-I & II HEALTHY, BATTERY-I & II: CHARGING BY FC-I & II RESPECTIVELY
2.	Float Charger Trouble	FCBC takes over as Standby float charger in Float mode; feeds the connected dc loads while float charging the battery	B/C-1: OPEN B/C-2: CLOSED B/C-3: CLOSED 1. CASE A: FC-I UNHEALTHY & FC-II HEALTHY SOLUTION: FCBC-I CHARGING BATTERY-I & FEEDING LOADS 2. CASE B: FC-II UNHEALTHY & FC-I HEALTHY SOLUTION: FCBC-II CHARGING BATTERY-II & FEEDING LOADS
3.	Power Supply Failure	Battery feeds the connected DC loads	B/C-1: OPEN B/C-2: CLOSED B/C-3: CLOSED BATTERY-I & II FEED THE CONNECTED DC LOADS OF EACH CORRESPONDING SECTION



**TECHNICAL SPECIFICATION FOR
220V DC BATTERY CHARGER**

2 X 500 MW TUTICORIN FGD TPS

SPECIFICATION NO. PE-TS-483-508-E002

VOLUME II B

SECTION -I

REVISION 0 | DATE 28.03.2022

SHEET 5 OF 18

4.	Normal Power supply Resumes	Battery to be boost charged by FCBC in boost mode, while any one of the float chargers (FC-I/II) feeds the DC loads	<p>1. CASE-A: FC-I & II HEALTHY BEFORE POWER SUPPLY FAILURE; SOLUTION: B/C-1: OPEN B/C-2: OPEN, FCBC-I: IN BOOST MODE CHARGING BATTERY-I FC-I: FEEDS THE CONNECTED DC LOADS OF CORRESPONDING SECTION B/C-3: OPEN, FCBC-II: IN BOOST MODE CHARGING BATTERY-II FC-II: FEEDS THE CONNECTED DC LOADS OF CORRESPONDING SECTION</p> <p>2. CASE B: FC-I UNHEALTHY & FC-II HEALTHY SOLUTION: B/C-1: CLOSED B/C-2: OPEN, FCBC-I: IN BOOST MODE CHARGING BATTERY-I B/C-3: OPEN, FCBC-II: IN BOOST MODE CHARGING BATTERY-II FC-II: FEEDS THE ENTIRE DC LOADS (OF BOTH SECTION)</p> <p>3. CASE C: FC-II UNHEALTHY & FC-I HEALTHY SOLUTION: B/C-1: CLOSED B/C-3: OPEN, FCBC-II: IN BOOST MODE CHARGING BATTERY-II B/C-2: OPEN, FCBC-I: IN BOOST MODE CHARGING BATTERY-I FC-I: FEEDS THE ENTIRE DC LOADS (OF BOTH SECTION)</p>
----	-----------------------------	---	--



**TECHNICAL SPECIFICATION FOR
220V DC BATTERY CHARGER**

2 X 500 MW TUTICORIN FGD TPS

SPECIFICATION NO. PE-TS-483-508-E002

VOLUME II B

SECTION -I

REVISION 0 | DATE 28.03.2022

SHEET 6 OF 18

4.3 Under normal conditions, Float charging current of the battery shall be supplied by the Float charger, which is continuously monitored. In case Float charger fails, the FCB charger will have to cut into circuit automatically to take over the functions of float charger, to provide occasional equalizing charge and to operate in Boost mode when battery voltage drops below a set value. Necessary arrangement shall be provided so that connected DC load shall not be subjected to high voltage during equalizing or boost charging the battery.

4.4 Under normal conditions, Float charger will cater continuous loads and trickle charging current of batteries. If load is high and exceeds the charger capacity, then excess load will be supplied by the battery. In case of failure of AC, battery will meet the DC load requirement. After restoration of power, the float charger will continue to supply the loads as well as trickle charge the battery. At a time, only one battery will be put to boost charge.

4.5 The Float-cum-Boost charger will be normally in stand-by (Auto Float/ Charge) mode and will cut into the circuit automatically

a) To provide occasional equalizing charge as required.

b) To take over the functions of float charger in case of its failure.

c) To operate in boost mode when battery voltage drops below a set value.

The float-cum-boost charger shall also have provision for float, equalising, and boost charging the battery through manual selection. Output of the chargers shall be controlled automatically as well as manually. AUTO/MANUAL selector switch along with voltage/current setter shall be provided for this purpose.

If float charger fails, it will be annunciated in the control room and stand-by float charger of the float cum boost charger will have to cut into the circuit manually by double pole double throw switch to take over the function of float charger.

In boost mode, FCB chargers are suitable to charge the fully discharged battery (at end cell voltage of 1.85V) up to 2.75V/ cell in 8 hours.

4.6 Suitable electrical interlock shall be provided in the charger to ensure that boost charging can commence only after the relevant load isolating breaker in the DCDB is open. This ensures availability of both redundant feeders to the loads when any charger is isolated from the system for boost charging. However, in case of failure of any charger, the other charger shall feed both sections of DCDB and provide trickle charging to both sets of battery.

Interlock shall be provided to ensure that the battery can be taken to boost mode only if either of the float chargers' viz FC-I & FC-II are healthy and running. Suitable defeating arrangement shall also be provided for initial charging of the battery.

The operational philosophy/mechanism of DC SYSTEM shall be developed by vendor and decided during detailed engineering for approval of BHEL/Customer without any commercial implication to BHEL.



**TECHNICAL SPECIFICATION FOR
220V DC BATTERY CHARGER**

2 X 500 MW TUTICORIN FGD TPS

SPECIFICATION NO. PE-TS-483-508-E002

VOLUME II B

SECTION -I

REVISION 0 | DATE 28.03.2022

SHEET 7 OF 18

4.7 Chargers will be solid state type, natural air cooled with Degree of Protection (DOP) IP-42, self regulating, silicon-controlled full wave rectifier, fully controlled, bridge configuration, auto and manual control type designed for single and parallel operation with battery and shall be provided with microprocessor based automatic voltage regulator for a close voltage stability even when AC supply voltage and DC load fluctuates. Effective current (load) limiting feature and filters on both input and output to minimise harmonics shall be provided. Charger shall have soft start feature, under/over voltage protection and earth fault detection. Voltage/Current control shall be stepless, smooth and continuous. Voltage control shall be possible either in 'Auto' mode or in 'Manual' mode. An auto-manual selector switch shall be provided for this purpose.

Chargers designed for single and parallel operation with battery and shall be provided with following features:

- The charger output regulation shall be $\pm 1\%$ from no load to full load with an input power supply voltage & frequency variation on feeding system.
- The charger will be provided with microprocessor based automatic digital voltage regulation in float mode and automatic constant current regulation in boost mode.
- Ripple content at rated continuous load will be limited to 1% (rms) with or without battery.
- DC voltage setting adjustment of AVR for float charging will be $\pm 10\%$ of nominal voltage.
- DC current adjustment for boost charging will be 30% to 100% of maximum boost charging current.
- Current stabilization for constant current regulator for boost charging will be $\pm 2\%$.
- The rectifier transformer for FCB shall have $\pm 2 \times 2.5\%$ taps on primary side. However, if wide input voltage variation is provided in the charger itself, meeting the voltage variation of the tap range, then taps on primary side are not required.
- Minimum permissible power factor at rated continuous load will be 0.8
- Voltage stabilization for constant voltage regulation will be:
(a) $\pm 1\%$ of set DC voltage with $\pm 10\%$ variation in supply voltage.
(b) $\pm 5\%$ during transient.
- The charger shall be self-protecting against all A.C and D.C transients and steady state abnormal currents and voltages
- Charger A.C input and D.C output shall be electrically isolated from each other and also from panel ground. Isolation shall also be provided between power and control circuits.



**TECHNICAL SPECIFICATION FOR
220V DC BATTERY CHARGER**

2 X 500 MW TUTICORIN FGD TPS

SPECIFICATION NO. PE-TS-483-508-E002

VOLUME II B

SECTION -I

REVISION 0 | DATE 28.03.2022

SHEET 8 OF 18

- One moving coil DC voltmeter and ammeter of size 96x96 mm of suitable range for float and boost charger with necessary shunts for local and remote metering. Meters shall have 90 deg scale, antiglare glass, $\pm 1\%$ accuracy with zero adjuster on the front.
- One moving coil centre zero ammeter, with shunt, size 96x96 mm to read discharge / charge current of the battery.
- Each battery charger is provided with one (1) no. voltage transducer and one (1) no. current transducer for monitoring the DC output and as analog input to DCS/PLC. DC voltage transducer at battery output shall be provided. Transducer shall have 4-20 mA dual output.
- Radio frequency suppressor/screening shall be provided with the charger to limit the noise level/interference to radio and other communication equipment to be installed in the same building
- The battery and charger is designed to limit fault level on DCDB to 25 kA.

Charger Construction

- a) The charger shall comprise a continuous line up of free-standing, floor mounted sheet steel panels, with access from both front and rear.
- b) In between the float and float-cum-boost charger panels, a central panel shall be provided. This panel shall house the battery terminals, load terminals, battery blocking diodes, and a few meters, annunciators and indicating lamps.
- c) The panels shall conform to the degree of protection IP-42. Minimum thickness of sheet metal used shall be 2 mm.
- d) Access doors shall be with concealed hinges and neoprene gaskets. Ventilating louvres shall be covered with fine wire mesh. Door over 600 mm width shall be of double-leaf design.
- e) All equipment within the panels shall be arranged in modular units and laid out with sufficient space for easy maintenance.
- f) All indicating instruments, control switches etc. shall be flush mounted on the front face of the panels. However, potentiometer shall be provided inside the panel. Nameplates of approved size and type shall be provided for all circuits and devices both at front & inside of the panel.



**TECHNICAL SPECIFICATION FOR
220V DC BATTERY CHARGER**

2 X 500 MW TUTICORIN FGD TPS

SPECIFICATION NO. PE-TS-483-508-E002

VOLUME II B

SECTION -I

REVISION 0 | DATE 28.03.2022

SHEET 9 OF 18

- g) All bus bar and bus connections shall be of high conductivity copper and adequately sized to limit the maximum temperature within the permitted value. All bus connection shall be silver plated.
- h) Heat-shrinkable insulating sleeves shall be provided for busbars. All bus connections shall be shrouded. Busbars shall be colour coded for easy identification.
- i) Busbars shall be supported and braced to withstand the stresses due to maximum short circuit current and also to take care of any thermal expansion.

Charger Equipment

- j) All power diode and control rectifiers shall be silicon type. Rectifier transformer shall be resin impregnated in vacuum, dry type, double wound with copper conductor and class-F insulated with temperature rise limited to class-B having off-circuit tap $\pm 2.5\%$ on primary side. LC filter suppressor shall be provided in the output to minimize ripple content and to keep the value within the specified limit. For rectifier transformer taps, if wide input voltage variation is provided in the charger itself, meeting the voltage variation of the tap range, then taps on primary side are not required.
- k) The diode & bridge elements shall be liberally sized for forward current, minimum momentary overloads & voltage spikes. The current & peak inverse voltage (PIV) should be chosen accordingly. Wherever necessary power semiconductor device shall be provided with over current and over temperature protection by using special fuses. Blocking diodes shall be fully rated and shall have redundancy so that failure of a single diode shall not incapacitate the system in any way.
- l) Isolating switches shall be heavy duty, load break type, operated by an external handle with provision for padlocking in ON and OFF position.
- m) Changeover switch shall be 3 position, 4 pole, load break type with minimum 2 NO + 2 NC auxiliary contacts. The switch shall be installed in such a manner that the operating handle shall be accessible only after opening the front door. Control switches shall be dust protected, heavy duty, switchboard type complete with escutcheon plates. Contacts shall be silver plated, rated 10A at operating voltage. Selector switch shall be maintained contact, lockable stay-put type with knob handle. Meter selector switch shall be four-position type.
- n) Ground fault detection switch shall be three-position type spring return to neutral. Ground fault relay shall be provided to detect DC system ground leakage current. Push button shall be heavy duty, shrouded, push to actuate type with colored button and inscription plate. Each push button shall have 2 NO + 2 NC contacts, rated 10A at 240V AC and 0.5A at 220V DC.
- o) Contactor shall be air-break type with hand reset type thermal overload relays having in built temperature compensator and single phase preventer.



**TECHNICAL SPECIFICATION FOR
220V DC BATTERY CHARGER**

2 X 500 MW TUTICORIN FGD TPS

SPECIFICATION NO. PE-TS-483-508-E002

VOLUME II B

SECTION -I

REVISION 0 | DATE 28.03.2022

SHEET 10 OF 18

- p) Fuses shall be HRC type and furnished complete with fuse bases and fittings of such design as to permit easy and safe replacement of fuse element. Semi conducting device fuses shall be fast-acting. All upstream fuses shall be properly coordinated with corresponding downstream fuses.
- q) Indicating lamps shall be clustered of LEDs suitable for the duty involved. The body shall be made of polycarbonate Unbreakable lens. LEDs shall be protected by inbuilt fuse with surge suppressor or leakage voltage glow protection. Both lamps and lens shall be replaceable from front.
- r) Meters shall be 96 x 96 mm switchboard type, 90 deg scale, antiglare glass, + 1% accuracy with zero adjuster on the front.

4.8 The following manual controls shall be provided on the front of each charger panel :-

- a) Charger ON/OFF push button.
- b) Selection of float or boost charge in case of float-cum-boost charger.
- c) Voltage setters for setting the output of float/ equalizing / boost charge. Setting shall be independent of each other so that setting of one voltage shall not require resetting other.
- c) Ground fault detection switch with indicating lamps.
- d) Current limit setter/ charging rate.
- e) Under/ Over voltage relay including battery earth fault monitoring relay.
- f) Acknowledge-Reset-Test push buttons for annunciation system.
- g) The color of reset buttons shall be BLACK.

MCCB shall be provided to receive incoming AC supply.

4.9 The rectifier shall utilize diodes / thyristors and heat sinks rated to carry 200% of the load Current continuously.

5.0 The voltage at load terminal will not exceed the limits of +10% and -15% of nominal System voltage for 220V DC system.

5.1 The 220V DC power cable between battery to DCDB and charger to DCDB will be single core XLPE copper cable (BHEL scope). The HRC fuse box shall be located near battery. The Main HRC fuse on battery and charger output shall also have alarm contact.

5.2 The charger shall be designed to operate at an ambient air temperature of 50°C. It will be located indoor but in a hot, humid and tropical atmosphere.

5.3 Suitable annunciation in DDCMIS shall be provided like charger trouble, battery on boost mode etc. Further 4-20mA signals to DDCMIS shall be provided for important parameters like charger O/P voltage, current and battery voltage.



**TECHNICAL SPECIFICATION FOR
220V DC BATTERY CHARGER**

2 X 500 MW TUTICORIN FGD TPS

SPECIFICATION NO. PE-TS-483-508-E002

VOLUME II B

SECTION -I

REVISION 0 | DATE 28.03.2022

SHEET 11 OF 18

Annunciations & 4-20mA signals shall be finalised during detailed engineering without any price implication.

- 5.4 The float-cum-boost charger and float charger will house load terminals, meters, annunciators and LED type indicating lamps.
- 5.5 Meters shall be provided with necessary shunts for local and remote metering. The instruments shall be flush mounted type, dust proof, moisture resistant and should have easy accessible means for zero adjustment.
- 5.6 For ungrounded DC system, suitable ground fault detection system shall be provided in the battery charger panel to detect the ground fault on either polarity for annunciation in the charger panel.
- 5.7 The rectifier-transformers and chokes shall have Class-F insulation with temperature rise limited to class-B insulation value.
- 5.8 The charger panels will have an enclosure DOP IP-42. The charger panels shall be painted with light grey shade (shade 631 of IS-5) with two coats of synthetic enamel paint from outside and shade 632 of IS-5 from inside.

5.9 Painting

- a) The sheet metal of the panels shall be thoroughly cleaned by chemical agents (7-tank process) as required to produce a smooth clean surface free of scales, grease and rust.
- b) Both interior and exterior surfaces of the panels shall be powder coated and finished with two(2) coats of paints of approved shades.
- c) The paint shall be carefully selected to withstand tropical heat, rain etc. The paint shall not scale off or crinkle or removed by abrasion due to normal handling.
- d) Sufficient quantity of touch up paint shall be furnished for application after installation at site.

5.10 Lamp/Space heaters/receptacles

- a. The charger panels shall be provided with:
 - i) Internal illumination lamp with door switch, the lamp shall be located in the ceiling and guarded with protective cage.
 - ii) Space heater with thermostat control
 - iii) 3 pin 6A receptacle with plug



TECHNICAL SPECIFICATION FOR 220V DC BATTERY CHARGER

2 X 500 MW TUTICORIN FGD TPS

SPECIFICATION NO. PE-TS-483-508-E002

VOLUME II B

SECTION -I

REVISION 0 | DATE 28.03.2022

SHEET 12 OF 18

iv) Communication plug

b) Lamp, heater and receptacle circuits shall have individual ON-OFF switch fuse units/MCCBs and shall be suitable for 240V AC supply.

5.11 Wiring/Cabling

a) The panels shall be completely wired-up. All wiring shall be routed through wiring troughs.

b) Internal wiring of the panels shall be done with 1100 V grade PVC insulated cables with stranded copper conductor of 2.5 mm² for control and current circuits and 1.5 mm² for voltage circuits.

c) Each wire shall be identified, at both ends, with interlocking type permanent markers bearing wire numbers as per Bidder's Wiring Diagrams. AC / DC wiring shall have separate color-coding.

d) Wire termination shall be made with crimping type connectors with insulating sleeves. Wires shall not be spliced between terminals.

e) All spare contacts of relays, timers, auxiliary switches and other devices shall be wired up to the terminal block. Gland plate shall be of 3 mm thick, non-magnetic material and suitable for single-phase cable entry from bottom. Cable terminal board with cable lugs and double compression cable glands shall be provided in each panel for termination of incoming and outgoing cable.

5.12 Terminal Block

a) 1100V grade, multi way terminal block complete with mounting channel, binding screws and washers for wire connections and marking strip for circuit identification shall be provided for terminating the panel wiring. Terminals shall be stud type, suitable for terminating 2 nos. 2.5 mm² stranded copper conductor and provided with acrylic insulating cover.

b) Not more than two wires shall be connected to any terminal. Spare terminals equal in number to 20% active terminals shall be furnished. Separate terminal blocks shall be used for AC/ DC wiring termination.

c) Terminal blocks shall be located to allow easy access. Wiring shall be so arranged that individual wires of an external cable can be connected to consecutive terminals.

d) Terminal blocks used for interface with DDCMIS via termination cabinet shall be suitably sized to facilitate proper termination of interconnecting cables.

5.13 Grounding

a) The charger panels shall have fully rated ground bus with two ground terminals, one at each end.

b) Each terminal shall comprise two bolt drilling with G.I. bolts, nuts and bimetallic washers for connecting to 50x6 mm G.I. flat. Ground bus shall be bolted to the panel structures, effectively grounding the entire assembly. The cases of meters, relays and switching devices shall be grounded through sheet steel structure.



**TECHNICAL SPECIFICATION FOR
220V DC BATTERY CHARGER**

2 X 500 MW TUTICORIN FGD TPS

SPECIFICATION NO. PE-TS-483-508-E002

VOLUME II B

SECTION -I

REVISION 0 | DATE 28.03.2022

SHEET 13 OF 18

c) Wherever, the schematic diagrams indicate a definite ground at the panel, a single wire for each circuit thus grounded shall be run independently to the ground bus and connected thereto.

5.14 Tropical protection

a) All equipment accessories and wiring shall have fungus protection, involving special treatment of insulation and metal against fungus, insects and corrosion.

b) Screens of corrosion resistant material shall be furnished on all ventilating louvres to prevent entry of insects.

5.15 Name Plate

a) Nameplates shall be provided for each panel and for each equipment/device mounted on it.

b) The material shall be anodised aluminium/lamicoid, 3 mm thick, with white letters on black background.

c) Nameplates shall be held by self-tapping screws. The size of nameplates shall be approximately 20 mm x 75 mm for equipment and 40 mm x 150 mm for panels.

d) Nameplates for panels shall be provided both on the front rear and also inside of the panels.

e) Control and meter selection switches shall have integral nameplates. Nameplates for all other devices shall be located below the respective devices both inside & outside of panel.

f) Instruments and devices mounted on the face of the panels shall also be identified on the rear with the instrument/ device number. The number may be painted on or adjacent to the instrument or device case.

g) Caution notice on suitable metal plate shall be affixed at the back of each panel.

h) Bus bar clamp-on sensor, 2 x 4 In. (50 x 101mm) opening-maximum D, current : 50A



**TECHNICAL SPECIFICATION FOR
220V DC BATTERY CHARGER**

2 X 500 MW TUTICORIN FGD TPS

SPECIFICATION NO. PE-TS-483-508-E002

VOLUME II B

SECTION -I

REVISION 0 | DATE 28.03.2022

SHEET 14 OF 18

6.0 ALARM, PROTECTION, METERING AND INDICATIONS

6.1 Fault indicating lamps for battery and chargers shall be provided on charger cubicle.

One (1) minimum twelve-points alarm facia shall be provided on each float charger panel and float-cum-boost charger panel, complete with proper actuating devices, circuitry, legends, push buttons (Accept, Reset and Test) and hooter

Each central panel shall be provided with one (1) minimum eight-point alarm facia, complete with proper actuating devices, circuitry, legend, push buttons, (Accept, Reset and Test) and hooter.

The arrangement shall be such that on occurrence of a fault, the corresponding window shall light up and stay lighted until the fault is cleared and the reset button is pressed.

Each time a window lights up, a master relay shall get energised to provide group alarm signals to remote control panel. Alarms should be compatible to PLC system of FGD Plant

Solid-state, audio-visual annunciation system shall be provided for battery chargers. Annunciation system shall operate on 220 V D.C.

6.2 Each charger shall be provided with audio visual alarm annunciation arrangement (min. 12 points), actuating devices, circuitry, legend and push buttons (accept, reject and test), and hooter for the following important alarms for various abnormal conditions. Also the initiating contacts shall be provided for remote alarm for each of the float cum boost chargers. The alarms shall be provided on the CRT in the control room.

- AC supply failure
- Charger overload
- Filter condenser fuse blown
- Battery on boost charge
- Battery on float charge
- Charger fail
- Battery earth fault
- DC output fuse blown
- SCR Fuse blown
- DC system under voltage in boost mode
- DC system under voltage in float mode
- Load limiter operated
- DC system over voltage in float mode
- DC system over voltage in boost mode
- AC input fuse blown

For all above alarms, a group alarm for each charger 'Battery Charger trouble' shall be provided for PLC. Separate contacts shall be provided for "Battery earth fault" annunciation at central back up panel (annunciation panel).

Each battery charger shall have minimum two (2) no's spare annunciation channels and



**TECHNICAL SPECIFICATION FOR
220V DC BATTERY CHARGER**

2 X 500 MW TUTICORIN FGD TPS

SPECIFICATION NO. PE-TS-483-508-E002

VOLUME II B

SECTION -I

REVISION 0 | DATE 28.03.2022

SHEET 15 OF 18

window facia. All alarm contacts shall be rated 5.0A at 220V DC and 10A at 240V AC.

6.3 Following protections shall be provided for battery and chargers:

- Under voltage protection for DC system
- Over voltage protection for DC system
- Current limiting and AC under voltage protection for chargers
- Over current protection on DC side
- Fuse for short circuit protection of the battery
- Earth fault protection for DC system
- Fuse failure indication on DC side
- Reverse polarity protection for charger
- Tropical protection

6.4 Each charger panel shall be provided with the following meters. Meters shall be 96 x 96 mm switchboard type, 90 deg scale, antiglare glass, ± 1 accuracy with zero adjuster on the front.

- AC input voltmeter (0-500V AC) with Voltmeter Selector switch
- AC input ammeter with Current Selector switch
- One (1) D.C. ammeter (for charger output, Range 0 – 150% of rated full Load charger output) .
- One (1) D. C. voltmeter (for charger output)
- One (1) D. C. voltmeter (for battery output voltage)
- One (1) D. C. ammeter for Battery charging/ discharging current (Centre zero type Ammeter)

6.5 Each Charger shall be equipped with LCD display, so the system or particular module operation parameters can be locally or remotely viewed / monitored. Following parameters to be displayed:

- Input AC voltage
- Input AC current
- Charging voltage
- Charging current
- Load voltage
- Load current
- Battery voltage
- Battery current

6.6 Charger panel shall also have the following minimum indications (cluster LED):

- a. Charger power supply ON (at all three phases)
- b. Charger DC output healthy.
- c. Control supply ON.
- d. DC supply healthy.
- e. Float / boost charger in operation (in float-cum-boost charger)



TECHNICAL SPECIFICATION FOR 220V DC BATTERY CHARGER

2 X 500 MW TUTICORIN FGD TPS

SPECIFICATION NO. PE-TS-483-508-E002

VOLUME II B

SECTION -I

REVISION 0 | DATE 28.03.2022

SHEET 16 OF 18

7.0 DISCHARGE RESISTOR

It shall be designed to perform periodic discharge tests. Resistor unit shall be an assembly consisting of copper nickel alloy wire/stainless steel grid elements supported by stainless tie rod. The resistor bank shall have adequate trimming facility (coarse and fine) to maintain a constant current against falling voltage during discharge operation. An ammeter shall be provided on the unit to monitor discharge current of battery.

Control shall be through rotary switches for step control of current against falling voltage with ON/OFF facility.

Rating shall be derived based on C10 discharge rate of the lead acid battery.

Discharge resistor shall be naturally air cooled with Enclosure protection DOP IP-30.

Control Scheme to be provided such that if any fan is tripped, local indication is to be provided and in case the temperature goes beyond a set non permissible value then discharge resistor needs to be isolated with local indication.

8.0 BATTERY FUSE BOX

Battery fuse of adequate rating meeting the load duty cycle (ANNEXURE-II)) shall be supplied. Battery fuse box shall have suitable termination arrangement for terminating the cables informed during detailed engineering stage.

Minimum rating of Battery Fuse Box shall be as indicated in the BOQ cum price schedule

9.0 All bus bars and bus connections shall be of high conductivity copper and adequately sized to limit the maximum temperature rise to 40° C from ambient temp (50° C) under rated load condition. The maximum allowable temperature rise shall be 55° C from ambient temp (50° C) at joints. All bus connections shall be silver-plated joined with two bolt connection with plain and spring washes and locknuts.

10.0 Bidder to furnish list of sub-vendor(s) for bought out items. Make of equipment / components shall be subject to BHEL/Customer approval after award of contract without any commercial implication.

11.0 For the purpose of design an ambient temperature of 50 deg.C and relative humidity of 85% shall be considered.

12.0 TESTS ON CHARGER

- 12.1 Following routine tests will be conducted on each charger:
- Visual checks for dimensions and general arrangement



**TECHNICAL SPECIFICATION FOR
220V DC BATTERY CHARGER**

2 X 500 MW TUTICORIN FGD TPS

SPECIFICATION NO. PE-TS-483-508-E002

VOLUME II B

SECTION -I

REVISION 0 | DATE 28.03.2022

SHEET 17 OF 18

- Wiring checks
- Functional checks
- Voltage regulation for rated input supply for loads from 0-100% with $\pm 10\%$ Input voltage variation
- Ripple measurement by oscilloscope at different loads
- Dielectric test
- Insulation test with 500V megger
- Load limiter test
- HV Test (2kV AC for 1 min excluding electronic controller)
- Efficiency & Power factor measurement
- Load test to show the charger can deliver the rated duty without the current limiter device operating
- Routine tests on components/parts.

12.2 Following type tests will be conducted on each charger:

- Heat run test on current limiting value.

Note: A set of special tools & tackle which are necessary or convenient for erection, commissioning, maintenance and overhauling of the equipment shall be supplied. The tools shall be shipped in separate containers, clearly marked with the name of the equipment for which they are intended.

12.3 Refer quality plan enclosed with this specification for detailed testing requirement. The Quality plan shall be subject to BHEL/ customer approval after award of contract without any commercial or delivery implication. Inspection shall be carried out as per BHEL/ customer approved Quality plan.

13.0 Bidder has to submit test certificates for their bought out items. Routine test certificates for components like contactors, relays, instruments, SCR / PWM transistors, Diodes, Condenser, Potentiometer, semi-conductors, push buttons etc. shall also be furnished for Owner's review and approval

14.0 Certified reports of all the tests carried out at the works shall be furnished in six (6) copies for approval of the Owner

15.0 Bidder shall submit type test reports for the type tests as per relevant standards on identical equipment in type and rating. Reports older than five (5) years of 18.04.2020 shall not be acceptable.

In case the type test reports are not submitted or the reports are not approved by the Purchaser, the Bidder shall conduct the type tests on the offered equipment at Bidder's risk and cost within the schedule specified herein. No deviation in this regard is acceptable.

	TECHNICAL SPECIFICATION FOR 220V DC BATTERY CHARGER	SPECIFICATION NO. PE-TS-483-508-E002	
		VOLUME II B	
		SECTION -I	
	2 X 500 MW TUTICORIN FGD TPS	REVISION 0	DATE 28.03.2022
SHEET 18 OF 18			

16.0 DELIVERY: Delivery of equipment shall be as per NIT.

BILL OF QUANTITY: The bidder to quote for items as per price schedule attached with the NIT. Supplier to also give the following undertaking in the BOM: “ The BOM provided herewith completes the scope (in content and intent) of material supply under PO No. ----- - Dtd. ----- . Any additional material which may become necessary for the intended application of the supplied items(s)/package will be supplied free of cost in most reasonable time”

17.0 DRAWINGS & DOCUMENTS TO BE SUBMITTED

18.1 Documents required along with Technical offer

Signed and Stamped copies of following documents:-

- a) Out line drawings of charger, battery fuse box.
- b) Unpriced Price Schedule as enclosed with NIT with “Quoted” word against items with bidder’s signature and company stamp.
- c) A copy of the sheet “Compliance certificate” with bidder’s signature and company stamp.
- d) “Deviation Schedule” with “NO DEVIATION” and bidder’s signature and company stamp.

18.2 Documents required after award of LOI

List of primary and secondary documents to be submitted during contract stage shall be as per NIT.

Note:-

1. Document mentioned at clause no. 18.2 above, shall be submitted through document management system (DMS).



**TECHNICAL SPECIFICATION FOR
220V DC BATTERY CHARGER**

SPECIFICATION NO. PE-TS-483-508-E002

VOLUME II B

SECTION I

2 X 500 MW TUTICORIN FGD TPS

REVISION 0 DATE: 28.03.2022

SHEET 1 of 3

DATASHEET-A

Sr. No.	PARAMETER	UNIT	VALUE
1.0	Power Supply & fault level details		
1.1	Rated AC voltage & variation	V, %	415 V, 3Ph, 3 Wire Systems, (-) 10% to (+) 10%
1.2	Frequency & variation	Hz, %	50 Hz, -5% to +5%
1.3	Rated DC voltage & variation	V, %	220 V, 187 V to 242V
1.4	Fault current of 415V system	kA	50 kA for 1 sec.
1.5	Fault current of DC system limited upto (max)	KA	The Charger shall be designed to restrict maximum fault level on DCDB limited to 25kA for 1 Sec.
1.6	Type/ Capacity of battery	MIN	1820 AH Lead-Acid Plante *Refer note 3 below
2.0	Charger current rating		
2.1	Float-cum-boost charger	A	400A for lead acid battery for FGD Plant
2.2	Float Charger	A	400A for lead acid battery for FGD Plant
3.0	Type of cooling		Natural air cooled
4.0	Ripple content of charger		
4.1	RMS	%	Limited to 1%
4.2	Peak to peak	%	
5.0	Degree of Protection (DOP)		
5.1	Rectifier transformer cubicle		IP-42
5.2	Control cubicle		IP-42
6.0	Constructional features		
6.1	Panel/frame sheet thickness/ material	mm	2.0mm Cold rolled sheet steel
6.2	Paint shade		shade 631 of IS 5 with two coats of synthetic enamel



**TECHNICAL SPECIFICATION FOR
220V DC BATTERY CHARGER**

SPECIFICATION NO. PE-TS-483-508-E002

VOLUME II B

SECTION I

2 X 500 MW TUTICORIN FGD TPS

REVISION 0 | DATE: 28.03.2022

SHEET 1 of 3

			paint. shade 632 of IS 5 from inside
6.3	Cable gland plate thickness/ material	mm	Removable undrilled 3 mm / Non-magnetic material
6.4	Gasket thickness/ material	mm	3 mm / Rubber /Neoprene
6.5	CABLE SIZES a) Cable size from battery to Fuse Box b) Cable size from Fuse Box to DCDB c) Cable from Charger to DCDB d) Cable Size For FCB Charger AC Incomer		For FGD plant: 1R-1CX300sq.mm(Cu)/Pole* XLPE Cable 1R-1CX300sq.mm(Cu)/Pole* XLPE Cable 1R-1CX300sq.mm(Cu)/Pole* XLPE Cable 1C X 400 SQMM(AL)/PH* 1C X 400 SQMM(AL) - N
7.0	Type Tests		
7.1	Type tests to be conducted for this contract, despite availability of valid & acceptable test certificates	Yes/ No	YES, As per Section –/ Quality plan. Heat Run test on current limiting value to be conducted on each charger
8.0	EARTHING		
8.1	Grounding terminal size/ no. for each charger		50X6 MM./ 2 nos.
8.2	Grounding terminal size/ no. for each fuse box		50X6 MM./ 2 nos.
8.3	Grounding terminal size/ no. for each discharge resistor		50X6 MM./ 2 nos.
9.0	Mandatory Spares		
9.1	Mandatory Spares to be quoted for this contract	Yes/ No	Yes
9.2	If yes, list of mandatory spares		Mentioned in BOQ cum Price Schedule
10	E & C Spares		
10.1	E & C Spares to be quoted for this contract	Yes/ No	Yes
10.2	If yes, list of E & C Spares		Mentioned in BOQ cum Price Schedule
11.0	Special tools & tackles		



**TECHNICAL SPECIFICATION FOR
220V DC BATTERY CHARGER**

SPECIFICATION NO. PE-TS-483-508-E002

VOLUME II B

SECTION I

2 X 500 MW TUTICORIN FGD TPS

REVISION 0 | DATE: 28.03.2022

SHEET 1 of 3

11.1	Special tools & tackles to be quoted for this contract	Yes/ No	Yes
11.2	If yes, list of Special tools & tackles		Bidder to furnish the list.
12	Battery Fuse Box	Fuses as per Load Duty Cycle for both Positive and Negative Pole shall be provided. Also Construction shall be same as Charger Panel and Battery Fuse Box shall be wall-mounted type. Minimum rating of Battery Fuse Box shall be as indicated in the BOQ cum price schedule.	
13	Discharge Resistor Panel	a) Portable type battery discharge resistor panels shall be supplied with shunt suitable for 10 hrs. Discharge rate (C10 rate) as per battery capacities indicated in the BOQ cum price schedule. b) Cooling of discharge resistor shall be natural air cooled. c) Construction shall be same as Charger panel. Handle and wheel arrangement shall be provided for easy movement. DOP shall be IP-30. d) Control - Using rotary switches for step control of current against falling voltage with ON-OFF facility.	

Notes

- 1) BHEL will provide 3 PH-3 wire power Supply. Further distribution for single Phase shall be created by Bidder.
- 2) *Min cable size and Nos. indicated. Actual cable size and number of runs shall be informed during detailed engineering.
- 3) Actual rating of Battery fuse box and discharge resistor panel shall be selected by the bidder based on load duty cycle (Annexure-II).

**TECHNICAL SPECIFICATION FOR
220V DC BATTERY CHARGER**

2 X 500 MW TUTICORIN FGD TPS

DATA SHEET-C

SPECIFICATION NO. PE-TS-483-508-E002

VOLUME II B

SECTION I

REVISION 0

DATE 28.03.2022

SHEET 1 OF 3

Sr. No.	PARAMETER	UNIT	VALUE
1.0	Manufacturer's Name		
2.0	Design ambient temperature		
3.0	Charger Rating & Type		
4.0	Charger rated output current:		
4.1	Trickle charging mode		
4.2	Boost charging mode		
5.0	Load limiter current setting range (Trickle mode)		
6.0	Automatic voltage regulator (Trickle mode)		
6.1	Type		
6.2	% Stabilization of the output DC voltage		
6.3	Voltage setting range		
6.4	Walk in time of Automatic Voltage Regulator		
6.5	Time taken to stabilize voltage for under shoot & overshoot		
7.0	Manual voltage regulator (Trickle mode)		
7.1	Type		
7.2	Voltage setting range		
8.0	Boost charging		
8.1	Current setting range		
8.2	Voltage limit setting range		
9.0	Rectifier assembly		
9.1	Type of semi-conductor material		
9.2	Rated direct current per cell (Average)		
9.3	SCR Rating Selected		
9.4	Heat sink for SCR		
9.5	Rated direct voltage		
9.6	Rated input voltage		
9.7	Type of connections of rectifier element		
9.8	Standard applicable		
9.9	Ripple content		



**TECHNICAL SPECIFICATION FOR
220V DC BATTERY CHARGER**

2 X 500 MW TUTICORIN FGD TPS

DATA SHEET-C

SPECIFICATION NO. PE-TS-483-508-E002

VOLUME II B

SECTION I

REVISION 0

DATE 28.03.2022

SHEET 2 OF 3

Sr. No.	PARAMETER	UNIT	VALUE
10.0	Rectifier transformer		
10.1	Type		
10.2	Rated KVA & % impedance		
10.3	Input line winding connection in vector representation		
10.4	Cell winding connection in vector representation		
10.5	1 min. power frequency withstand voltage (kV)		
10.6	Standard applicable		
11.0	Charger full load Efficiency at nominal input & output voltage & current		
12.0	Power factor at nominal input & output voltage & current		
13.0	Instrument		
13.1	Manufacturer		
13.2	Type		
13.3	AC voltmeter range		
13.4	DC voltmeter range		
13.5	DC Ammeter range		
13.6	Dial size		
13.7	Accuracy class as per IS		
14.0	Contactor		
14.1	Manufacturer		
14.2	Type		
14.3	Rated voltage		
14.4	Rated current		
14.5	No. of power contact		
14.6	No. type and rating of Aux. Contacts		
14.7	Operating coil voltage		
14.8	Drop-out voltage		
15.0	Thermal over load relay		
15.1	Manufacturer		



**TECHNICAL SPECIFICATION FOR
220V DC BATTERY CHARGER**

2 X 500 MW TUTICORIN FGD TPS

DATA SHEET-C

SPECIFICATION NO. PE-TS-483-508-E002

VOLUME II B

SECTION I

REVISION 0

DATE 28.03.2022

SHEET 3 OF 3

Sr. No.	PARAMETER	UNIT	VALUE
15.2	Tripping current range		
15.3	Whether single phasing protection provided		
15.4	Standard applicable		
16.0	Air - break switches (both DC & AC side)		
16.1	Manufacturer		
16.2	Type		
16.3	Rated voltage		
16.4	Rated current		
16.5	Type & material of contacts		
16.6	Standard applicable		
17.0	Output fuse		
17.1	Manufacturer		
17.2	Type		
17.3	Rupturing capacity (both AC & DC)		
17.4	Standard applicable		
18.0	Painting		
18.1	Paint shade		
18.2	Painting process		
19.0	Degree of Protection (DOP)		
19.1	Rectifier transformer cubicle		
19.2	Control cubicle		
20.0	Earthing busbar size & material		
21.0	Charger dimension: (approx.) [L x W x H]		
22.0	Sheet thickness (mm) / material		
23.0	Cable gland plate thickness		
24.0	Gasket material		
25.0	Charger weight (Kg.)		



**TECHNICAL SPECIFICATION FOR
BATTERY CHARGER**

SPECIFICATION NO. PE-SS-999-508-E002, Rev 02

VOLUME II B

SECTION D

REV 01

DATE: 28.03.2022

SHEET 1 OF 16

SECTION - D



**TECHNICAL SPECIFICATION FOR
BATTERY CHARGER**

SPECIFICATION NO. PE-SS-999-508-E002, Rev 02

VOLUME II B

SECTION D

REV 01

DATE: 28.03.2022

SHEET 2 OF 16

CONTENTS

<u>CLAUSE NO.</u>	<u>DESCRIPTION</u>	<u>PAGE NO.</u>
1.0	INTRODUCTION	2
2.0	CODES AND STANDARDS	2
3.0	OPERATIONAL REQUIREMENTS	2
4.0	BATTERY CHARGERS	2
5.0	DESCRIPTION OF EQUIPMENT	5
6.0	ANNUNCIATION SYSTEM	9
7.0	NAME PLATE AND MARKING	10
8.0	PAINTING	10
9.0	PERFORMANCE GUARANTEE	10
10.0	INSPECTION & TESTING	10
11.0	DOCUMENTATION	13
12.0	SPARES	15
13.0	TOOLS AND TACKLE	15
14.0	AS-BUILT DRAWINGS	15
15.0	STATUTORY AND REGULATORY REQUIREMENTS	15
ANNEXURE-1	LIST OF APPLICABLE STANDARDS	16



TECHNICAL SPECIFICATION FOR BATTERY CHARGER

SPECIFICATION NO. PE-SS-999-508-E002, Rev 02

VOLUME II B

SECTION D

REV 01

DATE: 28.03.2022

SHEET 3 OF 16

1.0 INTRODUCTION

This specification covers the design, manufacture, assembly, testing, packing and despatch of Battery charger (Float/Boost/Float cum Boost) complete in all respects with all components, fittings and accessories for efficient and trouble-free operation. The charger shall be connected either with Ni-Cd or Lead-acid type battery as applicable. In this specification though erection & commissioning is not included in vendor's scope, the vendor shall still not absolved of his responsibility of establishing the correctness of equipment at site.

2.0 CODES AND STANDARDS

The equipment shall generally conform to IS. Unless otherwise specified, the latest revisions of codes/ standards specified in Annexure-I enclosed are applicable.

3.0 OPERATIONAL REQUIREMENTS

3.1 Under normal conditions, when the AC supply is healthy at the battery charger input terminals, the float charger shall feed the continuous DC loads, while the boost charger shall remain off. Over and above the continuous DC loads the float charger shall also supply the necessary trickle charge to the battery, to keep the later in fully ready condition for being available during AC supply failure at charger terminals. Also some of the impulse loads of duration less than a minute for which the response of the charger is poor, shall be supplied by the associated battery in the DC system. This impulse discharge, shall, however, be continuously replenished by the float charger, unless the discharge is of considerable magnitude, in the event of which the boost charger shall be deployed.

3.2 The float charger shall withstand momentary supply failure due to changeover on AC supply feeding bus and continue to operate on float mode satisfactorily on restoration of AC supply to charger.

3.3 The DC system shall be ungrounded and shall float with respect to the ground potential when healthy.

3.4 After the batteries are boost charged and operation is changed to float mode, the voltage impressed on the loads shall not exceed float charge voltage.

3.5 The charger shall be designed to operate at an ambient air temperature of 50°C. It will be located indoor but in a hot, humid and tropical atmosphere.

3.6 The voltage at load terminal will not exceed the limits of +10% and -15% of nominal system voltage for DC system.

4.0 BATTERY CHARGERS

4.1 The battery chargers shall be self-regulating, natural air cooled, static type/microprocessor based composed of silicon controlled rectifiers (SCRs) connected in three phase full wave full control bridge circuit.

4.2 Each charger circuit shall be provided with its own AC input voltmeter with voltmeter selector switch, DC voltmeter & ammeter, battery DC output ammeter & voltmeter, battery charging



**TECHNICAL SPECIFICATION FOR
BATTERY CHARGER**

SPECIFICATION NO. PE-SS-999-508-E002, Rev 02

VOLUME II B

SECTION D

REV 01

DATE: 28.03.2022

SHEET 4 OF 16

- current ammeter, control switches, rectifiers, Auto/ Manual voltage regulators, load limiting device, etc. as required for the successful operation of the DC system.
- 4.3 The charger shall have auto voltage regulators to enable stepless, smooth and continuous voltage control. The chargers shall have the effective current limiting feature and smoothing filters on both input and output to minimise harmonics, radio frequency transients, electromagnetic transients, etc.
- 4.4 The battery chargers as well as their automatic regulators shall be of static type/ microprocessor based, the battery chargers shall be capable of continuous operation at the respective rated load in float charging mode i.e. trickle charging the associated DC batteries while supplying the DC loads.
- 4.5 The battery chargers shall have a selector switch for selecting the battery-charging mode i.e. float or boost charging.
- 4.6 The battery chargers shall be provided with facility for both automatic and manual control of output voltage and current. The selector switch will select the mode of output voltage/current control, whether automatic or manual. Necessary provisions shall be provided to avoid current/voltage surges of harmful magnitude/nature, which may arise during changeover from auto to manual mode or vice versa under normal operating condition.
- 4.7 Soft start feature shall be provided to build up the voltage to the set value slowly within 15 seconds. The chargers shall have load limiters, which shall cause, when the voltage control is in automatic mode, a gradual lowering of the output voltage when the DC load current exceeds the load limiter setting of the charger. The load limiter characteristic shall be such that any sustained overload or short circuit in DC system shall not damage the charger nor shall it cause blowing of any of the charger fuses. The charger shall not trip on overload or external short circuit. After clearance of fault, the charger voltage shall build-up automatically when working in automatic mode.
- 4.8 When on automatic control mode during float charging, the charger output voltage shall remain within $\pm 1\%$ of the set value for AC input voltage variation of $\pm 10\%$, frequency variation of $+3\%$ to -5% , a combined voltage & frequency (absolute sum) variation of 10% and a continuous DC load variation from zero to full load. Uniform and step less adjustment of voltage setting (in both auto/manual modes) shall be provided on the front of the charger panel covering the entire float charging output range specified. Step less adjustment of the load limiter setting shall also be provided from 80% to 100% of the rated output current for float charging mode.
- 4.9 During boost charging, the battery chargers shall operate on constant current mode (when automatic regulator is in service). The boost charging current can be adjusted continuously over a range of 50% to 100% of the rated output current for boost charging mode. The charger output voltage shall automatically go on rising, when operating in boost mode, as the battery charges up. For limiting the output voltage of charger, a potentiometer shall be provided on the front of the panel, whereby it shall be possible to set the upper limit of this voltage anywhere in the output range specified for boost charging mode. All voltage and current setting potentiometers shall be Vernier type/screw type. If setting of the upper limit in the output range is possible manually via the controller interface as per bidder's design, then separate potentiometer is not required.



TECHNICAL SPECIFICATION FOR BATTERY CHARGER

SPECIFICATION NO. PE-SS-999-508-E002, Rev 02

VOLUME II B

SECTION D

REV 01

DATE: 28.03.2022

SHEET 5 OF 16

- 4.10 Energising the charger with fully charged battery connected plus 10% load shall not result in output voltage greater than 110% of voltage setting. The time taken to stabilise within specified limits shall be less than 15 seconds.
- 4.11 Momentary output voltage of the Charger, without the Battery connected shall be within 94% to 106% of the voltage setting during sudden load Change from 100% to 20% of full load or vice versa. Output voltage shall return to, and remain, within the limits specified as mentioned elsewhere in less than 2 seconds after the above mentioned change.
- 4.12 In case of float-cum-boost charger, manufacturer shall offer an arrangement in which the voltage setting device for float charging mode is also used as output voltage limit setting device for boost charging mode, and the load limiter of the float charging mode is also used as boost charging current setting device.
- 4.13 Suitable filter circuits shall be provided in all the chargers to limit the ripple content (peak to peak) in the output voltage to 1%, irrespective of the DC load fluctuation even when they are not connected to a battery.
- 4.14 The charger shall have provision for termination of two sets of 415V AC incoming supply cables. Both the sets of terminals shall be paralleled at the input side of the AC Isolating switch. Changeover arrangement between the AC supplies shall be provided by the BHEL at the upstream end.
- 4.15 Ni-Cd Batteries shall be Trickle charged at 1.4 to 1.42 Volts per cell. Chargers shall be capable of boost charging the associated D.C. Battery at 1.53 to 1.7 Volts per cell in 8-10 hours. Lead Acid Batteries shall be Trickle charged at 2.25 Volts per cell. Chargers shall also be capable of boost charging the associated D.C. Battery at 2.3 to 2.89 Volts per cell in 8-10 hours. The Chargers shall be designed to operate, as mentioned above, at an ambient air temperature of 50°C. For the type of battery for the project, kindly refer Datasheet-A.

5.0 DESCRIPTION OF EQUIPMENT

5.1 Rectifier assembly

Rectifier assembly shall be full wave bridge type and designed to meet the duty as required by the respective charger. The rectifier cells shall be provided with their own heat dissipation arrangement with natural air-cooling. The rectifier shall utilise diodes / thyristors/IGBTs and heat sinks to carry 200% of the load current continuously and the temperature of the heat sink shall not be permitted to exceed 85°C absolute, duly considering the maximum charger panel inside temperature. Adequate snubber circuit shall be provided for the safety of thyristors, etc. The successful bidder shall furnish calculations to show what maximum junction temperature will be and what the heat sink temperature will be when operating at 200% and 100% load current continuously duly considering the maximum surrounding air temperature for these devices inside the charger panel at air ambient temperature of 50°C outside the panel. Necessary surge protection devices and rectifier type fast acting HRC/Semiconductor fuses shall be provided in each arm of the rectifier connections. Heat run test for other charger components shall be carried out at 100% of rated current.

5.2 Rectifier transformer and Chokes

The rectifier transformer & chokes shall be dry and air cooled (AN) type. The rating of the rectifier transformers & chokes shall correspond to the rating of the associated rectifier assembly and shall be copper wound. The rectifier transformers & chokes shall have Class-F insulation with



TECHNICAL SPECIFICATION FOR BATTERY CHARGER

SPECIFICATION NO. PE-SS-999-508-E002, Rev 02

VOLUME II B

SECTION D

REV 01

DATE: 28.03.2022

SHEET 6 OF 16

temperature rise limited to Class-B insulation value. The rectifier transformer sizing shall be done considering all the loads connected to it. The successful bidder shall furnish calculations for rectifier transformer sizing.

5.3 Blocking Diode

Blocking Diode shall be provided in the output circuit of each charger to prevent current flow from the DC battery into the charger. The successful bidder shall furnish calculations to show what maximum heat sink temperature will be when operating at 100% load current continuously duly considering the maximum surrounding air temperature for these devices inside the charger panel at air ambient temperature of 50°C outside the panel.

5.4 Voltage regulators

5.4.1 The float charger shall have both auto and manual voltage regulation arrangements. The voltage regulator shall have auto/manual option and be of static type. A selector switch for selection of the mode of voltage regulation shall be provided. AVR time constant shall not exceed 0.5.

5.4.2 The boost charger shall have auto/manual voltage regulation arrangement. The voltage adjustment shall be uniform and step less throughout the voltage variation range. The regulator shall be of static type. The boost charger shall be designed to charge the fully discharged battery to fully charged condition in 8 hrs.

Voltage regulators of Float/Boost Charger as part of controller are also acceptable. However, end user/customer requirement as specified in Sec-I will prevail.

5.5 Printed Circuit Boards (PCB)

PCB shall be made of glass epoxy of 1.6 mm thick, fire resistant, bonded with 99.8% pure copper foil, free of wrinkles, blisters, scratches and pinholes. The contact surface of the edge connectors of PCBs shall be plated with hard gold to a minimum thickness of 5 microns. The component identification shall be printed on PCB by Silk screen method. All PCBs shall be tropicalized and masked. The above requirement is indicative. Manufacturer standard design meeting high quality standards and performance are also acceptable.

5.6 Control and Selector Switches

The control and selector switches shall be of rotary stay put type with escutcheon plates showing functions and positions. The switches shall be of sturdy construction and suitable for mounting on panel front. The switches shall have shrouded live parts and sealed contacts against dust ingress. Auto/normal switch shall be of lockable type in either position. The contact ratings shall be at least the following:

- Make and carry continuously 10A
- Breaking current at 220V DC 0.5A (inductive)
- Breaking current at 240V AC 5.0A at 0.3 p.f.

5.7 Indicating Lamps

To indicate AC supply availability, three indicating lamps shall be provided. The indicating lamp shall be suitable for panel mounting, cluster type LED and capable of clear status indication under normal room illumination. The lamp covers shall be preferably screw type, unbreakable and moulded from heat resistant material.



TECHNICAL SPECIFICATION FOR BATTERY CHARGER

SPECIFICATION NO. PE-SS-999-508-E002, Rev 02

VOLUME II B

SECTION D

REV 01

DATE: 28.03.2022

SHEET 7 OF 16

5.8 Instruments

For all chargers, DC ammeter, DC voltmeter and AC voltmeter shall be provided in 96 x 96 mm² size with 0.5 accuracy class conforming to IS-1248. The instruments shall be flush mounted type, dust proof, moisture resistant and have easy accessible means for zero adjustment. Meters shall have 4 digit-7 segment LED/LCD display and RS 485 Serial Bus port for remote communication.

5.9 Relays

The relays shall be enclosed in flush or semi flush dust tight cases finished with dull black enamel paint. Relays shall have self-contained test facilities and provisions for removing relay mechanism for inspection and maintenance.

5.10 Transducers

Transducers shall be panel-mounting type and suitable for operating temperatures from 0 to 55°C. Transducer output shall be used for remote display at DDCMIS. Transducers shall be provided in charger panel for DC battery voltage, charger output voltage and charger output current. The transducer shall have the following features:

- Input/ output with galvanic isolation
- Auxiliary voltage – 220V DC
- 4-20 mA independent dual output
- Accuracy class 0.5 or better
- Short circuit and over current protection

5.11 Contactors

All battery chargers shall have an AC contactor on the input side. It shall be of air break type and suitable for continuous duty. The operating coil shall be rated for 415 V/400V/380V as per project requirement. The DC contactors shall be single/double pole air break type and suitable for continuous duty.

5.12 Thermal overload relay

A thermal overload relay with single phasing protection (using differential movement of bimetal strips) shall also be provided for the AC input, which will trip the contactor. Thermal overload relay part of controller/designed with control cards are also acceptable.

5.13 Air break switches / MCCB

All chargers shall have AC input and DC output switches of air break, single throw, load break and fault make type or MCCB type as per project requirement. The contacts of the switches shall open and close with a snap action. The switches/MCCB shall be rated for 120% of the maximum continuous load. The 'ON' and 'OFF' position of the switch/MCCB shall be clearly indicated. The operating handle of the switches/MCCB shall be fully insulated from circuit and shall be effectively earthed.

Incoming/outgoing supply shall be MCCB or SFU as per project specific requirement specified in Section-I of the specification.

5.14 Fuses

Incoming/outgoing power supply fuses shall be of HRC cartridge fuse link type. Fuses shall be mounted on fuse carriers, which are mounted on fuse base. Wherever, it is not possible to mount fuses on fuse carriers, fuses shall be directly mounted on plug-in type bases. In such cases one insulated fuse pulling handle shall be supplied for each charger. Kick-off fuses (trip fuses) with alarm contacts shall be provided for all DC fuses. The fuses shall be suitable for applicable fault level. For electronic circuits, high speed semiconductor fuses may be used.



TECHNICAL SPECIFICATION FOR BATTERY CHARGER

SPECIFICATION NO. PE-SS-999-508-E002, Rev 02

VOLUME II B

SECTION D

REV 01

DATE: 28.03.2022

SHEET 8 OF 16

5.15 Variable Metallic Resistor (Discharge Resistor)

Variable metallic resistors and shunt suitable for carrying out discharge tests (5-hour discharge rate for Ni-Cd battery and 10-hour discharge rate for Lead Acid battery) on the batteries shall be supplied. The Discharge resistor unit shall be of robust assembly consisting of Copper-Nickel Alloy /FeCrAl/ Ni-chrome /Punched Steel Grid elements as per project specific requirement. The Discharge Resistor fan shall be designed to allow rapid, forced cooling of resistor bank.

5.16 Battery fuse box / MCCB Box

Battery fuse / MCCB of adequate rating meeting the load duty cycle shall be supplied. Suppliers have to furnish DC fuse/MCCB characteristics in support of the rating selected for the Battery Fuse Box. Battery fuse box / MCCB Box shall have suitable termination arrangement for terminating the incoming & outgoing cables informed during detailed engineering stage. Suitable cable lugs & glands have to be supplied with the equipment which shall be in Battery Charger Vendor scope.

MCCB or SFU as per project specific requirement specified in Section-I of the specification.

5.17 Panel Construction

The charger panels housing all the equipment shall be indoor, floor mounting, air natural cooled, self-supporting sheet metal enclosed cubicle type. The charger panel and its frame shall be fabricated from 1.6 and 2.0 mm cold rolled sheet steel respectively and have folded type construction. The bidder shall also supply necessary base frames, anchor bolts and hardware. Removable undrilled gland plates of at least 3.0 mm thick sheet steel and lugs for all cables shall be provided. The lugs for cables shall be made of electrolytic tinned copper. The gland plate shall be of adequate size for accommodating requisite number of cable glands for power and control cables. The charger shall be tropicalized and vermin proof. Ventilation louvers shall be backed with fine brass wire mesh. All door and covers shall be fitted with synthetic rubber/Neoprene gaskets. The panels shall have hinged double leaf doors provided on front and backside for adequate access of charger terminals. All the charger cubicle doors shall be properly earthed. The panels shall comply with at least degree of protection IP-42. Incoming and outgoing cables shall enter from bottom. Suitable cable terminal board with copper cable lugs and double compression brass nickel-plated cable glands shall be provided (which shall be in Battery Charger Vendor scope) in each panel for incoming and outgoing cables.

5.18 Electronic equipment shall be of modular design consisting of plug-in modules in standard 19 inches' metallic racks with metallic card guides. The card should be provided with proper handles. Card to card wiring shall be through mother board. Unplanned jumpering and track modifications shall not be allowed. Mechanical interlocks to prevent wrong insertion of cards shall be provided. Each card shall have its junction and test points identified. Maintenance aids such as extension printed wiring boards and jumper leads shall be provided. Non modular design is also acceptable.

5.19 The layout of charger components shall be such that their heat losses do not give rise to excessive temperature within the charger panel surface. Location of the electronic modules will be such that temperature rise of the location, in no case, shall exceed 10°C over ambient air temperature outside the charger.

5.20 All the charger panels shall be provided with an illuminating lamp, a 5 Amp socket and space heaters with thermostat. Toggle switches and fuses shall be provided separately for each of the above fittings. Space heaters "ON" indication shall be provided. Two separate grounding pads shall be provided for each panel.



TECHNICAL SPECIFICATION FOR BATTERY CHARGER

SPECIFICATION NO. PE-SS-999-508-E002, Rev 02

VOLUME II B

SECTION D

REV 01

DATE: 28.03.2022

SHEET 9 OF 16

5.21 Locking facility

Locking facility shall be provided as follows:

For locking float/boost selector switch in the float position only. This shall be used for having key mechanical interlock between float/boost selector switch and isolator in DCDB.

The charger enclosure door-locking requirement shall be met by the application of padlocks. Padlocking arrangement shall allow ready insertion of the padlock shackle but shall not permit excessive movement of the locked parts with the padlock in position.

5.22 Control wiring

Each panel shall be furnished completely factory wired upto power cable lugs and terminal blocks ready for external connections. The power wiring shall be carried out with 1.1kV grade, PVC insulated cables conforming to IS-1554 (Part-1). The control wiring shall be of 1.1kV grade, 1 core stranded copper wire with colour coded PVC insulation having identification ferrules at both terminal and device end for each wire. Wires shall conform to IS-694 and minimum size of the wire shall not be less than 2.5 mm². The control wiring terminating at electronic card shall not be less than 1.0 mm². The control terminal shall be suitable for connecting two wires with 2.5 mm² stranded copper conductors. All terminals shall be numbered for ease of connections and identification.

Power & control wiring within the panel shall be kept separate. Any terminal or metal work, which remains alive at greater than 415V, when panel door is opened, shall be fully protected by shrouding.

An air clearance of at least 10mm shall be maintained throughout all circuits, except low voltage electronic circuits, right upto the terminal lugs. Whenever this clearance is not available, the live parts shall be insulated or shrouded.

5.23 Terminal Blocks

Terminal blocks for all the chargers shall meet the following requirements:

- a) Terminal block shall be 1.1kV grade, minimum 10A rated, one piece moulded complete with insulating barrier, clip on type terminals, washers, nuts and identification strip etc. It shall be similar to Klippon type RSF with insulating material of melamine or equivalent. Marking on terminal strips shall correspond to the terminal numbering on wiring diagrams. Terminal blocks for CT & VT secondary leads shall be provided with links to facilitate testing, isolation, star/delta and earthing. Terminal blocks for CT secondary shall have the short-circuiting facility.
- b) At least 20% spare terminals for external connections shall be provided on each panel and these spare terminals shall be uniformly distributed on all terminal blocks.
- c) There shall be minimum clearance of 250mm between the terminal blocks and the cable gland plate and 150mm between two rows of terminal blocks.

5.24 Cable Lugs

Heavy duty bolt-on termination tinned copper lugs of compression type shall be used in the Charger for power cable termination. The supply of tinned copper cable lugs for power cables forms part of the supply of equipment. Cable lugs shall comply with IS-8309.



TECHNICAL SPECIFICATION FOR BATTERY CHARGER

SPECIFICATION NO. PE-SS-999-508-E002, Rev 02

VOLUME II B

SECTION D

REV 01

DATE: 28.03.2022

SHEET 10 OF 16

5.25 Cable Glands

The supply of cable glands forms part of the supply of equipment. Cable glands shall conform to BS-6121. Cable glands shall be of double compression type.

5.26 Panel Earthing

Charger panels shall have fully rated GI ground bus with two ground terminals, one at each end of the panel. Each ground terminal shall have two bolt drillings with GI bolts and nuts suitable for connection to purchaser's ground conductor.

6.0 ANNUNCIATION SYSTEM

6.1 Visual indication shall be provided to indicate the operating conditions of the charger by the means of indicating lamps/LED or annunciation facia windows as per EEUA-45D, arranged on the top of the charger panels for following faults:

- a) AC supply failure
- b) AC input fuse failure (separate for FCBC/Float/Boost)
- c) AC Under voltage/Overvoltage
- d) Rectifier fuse failure
- e) Charger failure
- f) Surge circuit fuse failure
- g) Filter fuse failure
- h) Blocking Diode failure
- i) Load limiter operated
- j) Charger trip/over loaded
- k) Battery on boost
- l) Charger earth fault
- m) Battery fuse blown
- n) Boost Bus Overvoltage
- o) DC system under voltage/over voltage

Potential free 'NO' contacts of all above conditions shall be provided for following remote alarms in the DDCMIS:

- q) Battery fuse fails
- r) Battery on boost
- s) Charger over load
- t) Charger trouble (this being a group alarm initiated by any of the faults of charger other than charger over load).

6.2 Suitable potential free contacts for remote indication of above abnormal conditions shall be provided. Multiplication relays, if required, shall be included in the panel. Indications for charger input supply healthy, charger in FLOAT mode and charger in BOOST mode shall be provided.

7.0 NAME PLATE AND MARKING

The name plates shall be made of non-rusting metal / 3 ply Lamicaid and shall have black back ground with white engraved letters and secured by screws. These shall be provided near top edge on the front as well as on rear side of charger. Name plates with full and clear inscriptions shall also be provided on and inside the panels for identification of the various equipment.



TECHNICAL SPECIFICATION FOR BATTERY CHARGER

SPECIFICATION NO. PE-SS-999-508-E002, Rev 02

VOLUME II B

SECTION D

REV 01

DATE: 28.03.2022

SHEET 11 OF 16

8.0 PAINTING

After fabrication, all surfaces shall be cleaned and pre-treated as per IS:6005. Two coats of lead oxide primer (anti-corrosive) shall be applied after the pre-treatment. Two coats of powder painting with shade no. RAL-7032 or paint shade approved by customer shall be applied for complete panel. Thickness of paint shall be min. 40-50 microns. Protecting peelable compound shall be provided on outside finished surface to protect the painted surface during transportation and site handling.

9.0 PERFORMANCE GUARANTEE

The bidder shall guarantee that chargers offered shall meet the ratings and performance requirements stipulated for various equipment covered in this specification. If the equipment fails to meet the requirement, the supplier shall replace it with appropriate equipment free of cost without affecting the schedule.

10.0 INSPECTION & TESTING

10.1 The bidder shall confirm compliance to Quality plan enclosed with Section-I of specification. The Quality plan shall be subject to BHEL/ customer approval after award of contract without any commercial or delivery implication. Inspection shall be carried out as per BHEL/ customer approved Quality plan.

10.2 All equipment to be supplied shall be of type-tested quality. The bidder shall furnish all type test reports for BHEL/ customer approval. The Type tests should have been carried out within last ten years on the equipment similar to those proposed to be supplied under this contract and the tests should have been either conducted at an independent laboratory or should have been witnessed by a client/ government agency. In absence of such type tests reports or in case such reports are not found to be meeting the specification/ standards requirements, vendor shall conduct all such type tests without any commercial/ delivery implication to BHEL according to the relevant standards and reports shall be submitted to the owner for approval. Charges for carrying out all type tests are deemed to be included in the charger price.

10.3 The details of additional Type Tests to be conducted (as per project specific requirement) shall be as per Section-I/BOQ-Cum-Price Schedule of specification.

10.4 The bidder shall furnish following Type Tests reports for each type & rating of battery charger:

- i) Temperature rise test at full load for 8 Hrs.
- ii) Temperature rise test for 8 Hrs for rectifier assembly at current specified in Data Sheet-A, Section-I.
- iii) Insulation resistance test
- iv) High voltage test on power & control circuits except low voltage electronic circuit
- v) Ripple content test at no load, half and full load
- vi) Automatic voltage regulation operation test at specified AC supply variations at no load, half and full load



**TECHNICAL SPECIFICATION FOR
BATTERY CHARGER**

SPECIFICATION NO. PE-SS-999-508-E002, Rev 02

VOLUME II B

SECTION D

REV 01

DATE: 28.03.2022

SHEET 12 OF 16

vii) Load limiter operation test.

viii) Efficiency and power factor measurement.

ix) Input and output surge withstand capacity test. Surge voltage as per ANSI-C37.90a shall be applied for a period of not less than 2 seconds at the following points of the charger operating at 50°C at full load:

- a) Across each AC input phases
- b) Across AC input line to ground
- c) Across DC output terminals
- d) Across each DC output terminal to ground

The charger shall not exhibit any component damage and there shall be no deterioration in performance of the charger.

x) Environmental Tests: Steady state performance tests (temperature rise test at full load & load limiter operation test) shall be carried out before & after the following tests.

a) Soak test: The electronic modules shall be subject to continuous operation for a minimum period of 72 hours. During last 48 hours, the ambient temperature shall be maintained at 50°C. The 48-hour test period shall be divided into 4 equal 12 hour segments. The input voltage during each 12 hours shall be nominal voltage for 11 hours followed by 110% of nominal voltage for 30 minutes, followed by 90% of nominal voltage for 30 minutes.

b) Degree of protection test

xi) Complete physical examination

xii) Dynamic response test

Overshoot / undershoot in output voltage of the charger corresponding to sudden change in load from 100% to 20% and from 20% to 100%.

10.5 Rectifier transformers shall be subjected to following routine test as per IS: 11171:

- a) Measurement of DC winding resistance
- b) Measurement of voltage ratio and check of voltage vector relationship
- c) Measurement of impedance of voltage (principal tapping), short-circuit impedance and load loss
- d) Measurement of no-load loss (iron loss) and current
- e) Separate-source voltage withstand test
- f) Insulation resistance test
- g) Induced overvoltage withstand test
- h) High voltage Test
- i) Temperature rise test for 8 Hrs.



TECHNICAL SPECIFICATION FOR BATTERY CHARGER

SPECIFICATION NO. PE-SS-999-508-E002, Rev 02

VOLUME II B

SECTION D

REV 01

DATE: 28.03.2022

SHEET 13 OF 16

10.6 Following routine tests are to be performed on all battery chargers:

- i) Complete physical examination.
- ii) Insulation resistance test.
- iii) High voltage (power frequency) test.
- iv) Ripple content test at no load, half and full load.
- v) AVR operation test at specified AC supply variation at no load, half and full load.
- vi) Load limiter operation test.
- vii) Checking of proper operation of annunciation system.
- viii) Dynamic response test
Overshoot / undershoot in output voltage of the charger corresponding to sudden change in load from 100% to 20% and from 20% to 100%.
- ix) Burn in test shall be carried out on all electronic modules or panels with modules. During the test the panel / module shall be subjected to ambient temperature of 50°C for 48 hours in energised condition. The temperature rise inside the cubicle shall not exceed 10°C during the test.
- x) Degree of protection test
The charger shall be checked for gasket arrangement as per the drawings.
- xi) Efficiency and power factor measurement.

10.7 Following routine tests shall be carried out on annunciation system:

- i) Annunciation assembly and module shall be functionally tested as per EEUA-45D.
- ii) Burn in test as specified above in cl. No. 10.5 (ix) above.

10.8 All material used for the construction of the equipment / items shall be new and shall be in accordance with the requirements of this specification. Materials utilised shall be those, which have established themselves for use in such applications.

10.9 All acceptance and routine tests as per relevant standards and specification, shall be carried out by the manufacturer. Charges for all these routine and acceptance tests for all the materials shall be deemed to be included in the charger price.

11.0 DOCUMENTATION

11.1 Documents to be submitted by the Bidder along with the bid:

- 1) Clause wise deviation if any in the enclosed format as per NIT.



**TECHNICAL SPECIFICATION FOR
BATTERY CHARGER**

SPECIFICATION NO. PE-SS-999-508-E002, Rev 02

VOLUME II B

SECTION D

REV 01

DATE: 28.03.2022

SHEET 14 OF 16

- 2) Unpriced Price Schedule (as per NIT) with “quoted” word against line item with bidder’s signature and company stamp.
- 3) Compliance Sheet(Sec-I) with bidder’s signature and company stamp.

11.2 Over and above the documents mentioned in 11.1, the following minimum documents are to be submitted after the award of the contract for purchaser’s approval:

- 1) Brief write-up on the working of the system offered along with Installation, operation and maintenance manual for the battery charger, battery fuse and variable metallic resistor and shunt.
- 2) Data Sheet-C
- 3) General arrangement drawing showing the battery charger, Fuse Box & discharge resistor.
- 4) Wiring diagram.
- 5) Quality plan.
- 6) Transformers KVA and voltage rating calculation.
- 7) Thyristors rating, heat sink and fuse co-ordination calculation.
- 8) Blocking Diode rating & heat sink calculation.
- 9) Filter circuit calculation.
- 10) AC power consumption in float mode & boost mode.
- 11) List of make of major components.
- 12) Test certificates as required/ type test procedures
- 13) Field quality plan. Bidder shall furnish field quality plan detailing out the specific quality control procedure covering receipt of material/equipment and handling at site, storage, erection, commissioning, post commissioning etc.
- 14) List of E&C Spares
- 15) List of Mandatory Spares (If Applicable)

11.3 Instruction Manuals

Instruction manuals for the installation, operation and maintenance of battery charger, battery fuse and variable metallic resistor and shunt to be supplied at least two months before the date of despatch of equipment.

The installation and maintenance manual of battery charger, battery fuse and variable metallic resistor and shunt shall contain the following.

- A) General description giving type and rating of equipment.
- B) Technical data.
- C) Salient constructional details.
- D) Instruction to be followed on receipt at site.



**TECHNICAL SPECIFICATION FOR
BATTERY CHARGER**

SPECIFICATION NO. PE-SS-999-508-E002, Rev 02

VOLUME II B

SECTION D

REV 01

DATE: 28.03.2022

SHEET 15 OF 16

- E) Erection procedures and checks (handling at site, erection, pre-commissioning).
- F) Commissioning procedures and site tests.
- G) Routine, periodic and preventive inspection and maintenance procedures.
- H) Safety rules.
- J) Possible faults, their causes and remedies.
- K) Catalogues, literature and drawings.
- L) Outline dimension drawings showing constructional features, relevant cross sectional views and earthing details, operator oriented description of equipment and accessories.
- M) Operating procedures, maintenance procedures & precautions to be taken during operation and maintenance work.

12.0 SPARES

12.1 Bidder to furnish the E & C spares as per BOQ-Cum-Price Schedule.

13.0 TOOLS AND TACKLE

Tools & tackle, which are essential to facilitate assembly, adjustments, maintenance & dismantling of equipment shall be provided as part of equipment supplied. The above tools shall be supplied along with the initial consignment of equipment so as to be available prior to erection but may not be used for erection purposes.

14.0 AS-BUILT DRAWINGS

Though only supply of equipment is under bidder's scope, bidder may note that all as-built correction (as given by purchaser to vendor) shall have to be incorporated in the originals by the vendor and copies of the as-built corrected drawings / documents as per requirement shall be submitted by the vendor.

15.0 STATUTORY AND REGULATORY REQUIREMENTS

Statutory and regulatory requirements as per IE rule 1956 with amendment-3 rule 1986, rules Nos. 35, 42, 50 & 51 shall be adhered to.



**TECHNICAL SPECIFICATION FOR
BATTERY CHARGER**

SPECIFICATION NO. PE-SS-999-508-E002, Rev 02

VOLUME II B

SECTION D

REV 01

DATE: 28.03.2022

SHEET 16 OF 16

ANNEXURE-I

LIST OF APPLICABLE STANDARDS

- | | | |
|-----|--|-----------------|
| 1. | GUIDE FOR SURGE WITHSTAND CAPABILITY TESTS | ANSI-C 37.90a |
| 2. | COLOURS FOR READY MIX PAINTS | IS-5 |
| 3. | PVC INSULATED CABLE FOR WORKING VOLTAGE 1100V | IS-694 |
| 4. | INDICATING ANALOGUE ELECTRICAL MEASURING INSTRUMENTS | IS-1248 |
| 5. | DOP FOR LV SWITCHGEAR AND CONTROL GEAR | IS-13947 PART-1 |
| 6. | SPECIFICATION FOR LV SWITCHGEAR AND CONTROL GEAR | IS-13947 |
| 7. | ELECTRICAL RELAYS FOR POWER SYSTEM PROTECTION | IS-3231 |
| 8. | APPLICATION GUIDE FOR ELECTRICAL RELAYS FOR AC SYSTEM | IS-3842 |
| 9. | MONO CRYSTALLINE SEMICONDUCTOR RECTIFIER CELLS & STACKS | IS-3895 |
| 10. | MONO CRYSTALLINE SEMICONDUCTOR RECTIFIER ASSEMBLIES & EQUIPMENT | IS-4540 |
| 11. | CODE OF PRACTICE FOR PHOSPHATING OF IRON & STEEL | IS-6005 |
| 12. | SAFETY CODE FOR SEMICONDUCTOR RECTIFIER EQUIPMENT | IS-6619 |
| 13. | CONTROL SWITCHES (SWITCHING DEVICES FOR CONTROL AND AUXILIARY CIRCUITS INCLUDING CONTACTOR RELAYS) FOR VOLTAGE UPTO 1000V AC OR 1200V DC | IS-6875 |
| 14. | ENVIRONMENTAL TESTING FOR ELECTRONIC & ELECTRICAL ITEMS | IS-9000 |
| 15. | LV FUSE FOR VOLTAGES BELOW 1000V AC OR 1500V DC | IS-13703 |
| 16. | PERFORMANCE REQUIREMENT FOR ALARM ANNUNCIATION SYSTEM | EEUA-45D |
| 17. | POWER TRANSFORMERS | IS-2026 |
| 18. | DRY TYPE TRANSFORMER | IS-11171 |
| 19. | INDIAN ELECTRICITY RULES & INDIAN ELECTRICITY ACTS | |

NOTE: Equipment complying to other internationally accepted standards such as IEC, BS, VDE etc. will also be considered if they ensure performance and constructional features equivalent or superior to standards listed above. In such a case, the bidder shall clearly indicate the standards adopted, furnish a copy in English of the latest revision of the standards along with copy of all official amendments and revisions and shall clearly bring out the salient features for comparison.



**TECHNICAL SPECIFICATION FOR
220V DC BATTERY CHARGER**

SPECIFICATION NO. PE-TS-483-508-E002

VOLUME II B

SECTION -I

2 X 500 MW TUTICORIN FGD TPS

REVISION 0 | DATE 28.03.2022

SHEET 1 OF 1

ANNEXURE-II

LOAD DUTY CYCLE FOR FGD PLANT DC SYSTEM

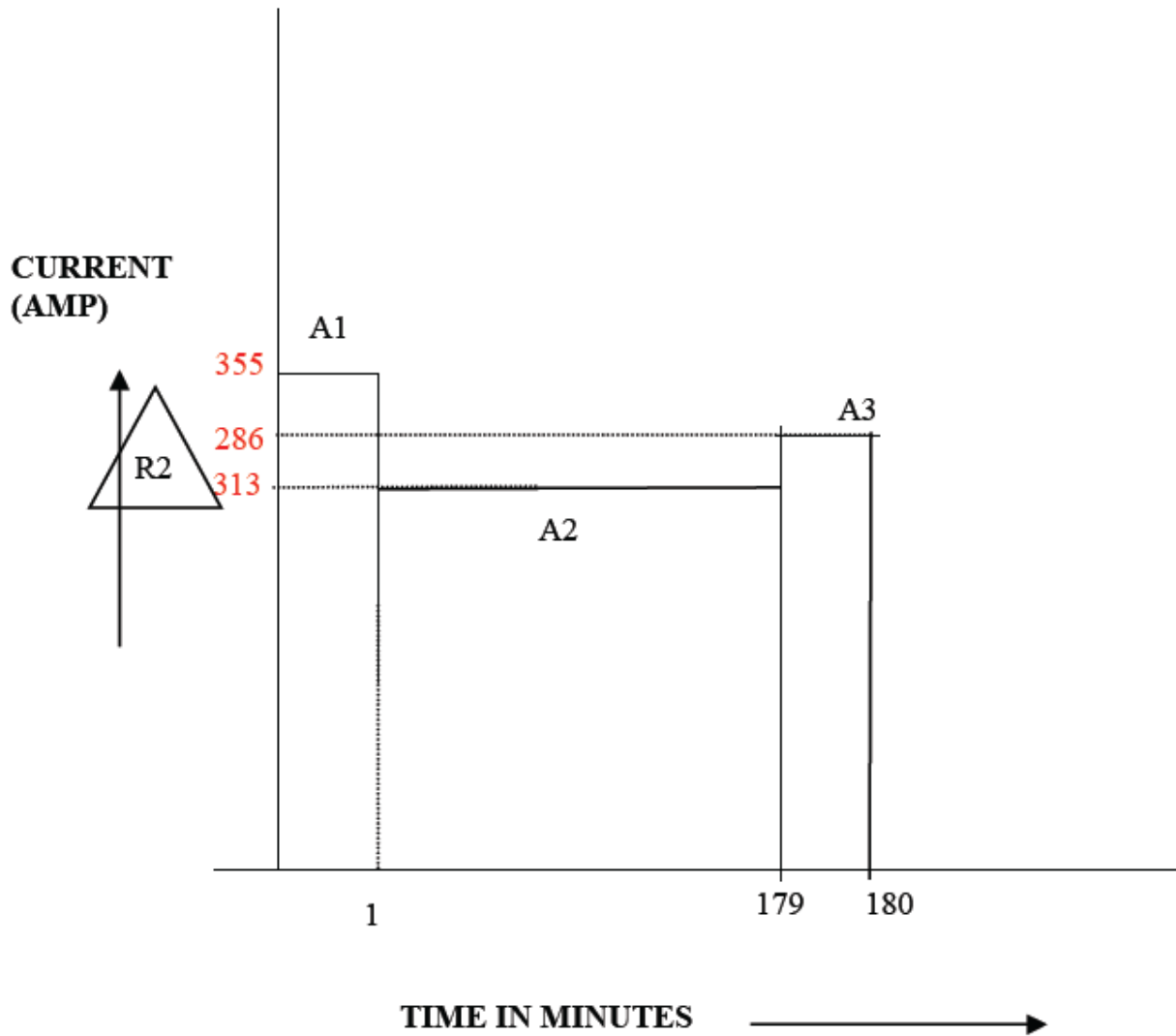

TECHNICAL SPECIFICATION FOR 220V DC BATTERY CHARGER
PE- TS- 483-508-E002
ANNEXURE III
2 X 500 MW TUTICORIN FGD TPS
SUB VENDOR LIST

ITEM CODE	ITEM/SERVICE DESCRIPTION	VENDOR NAME	ADDRESS	PHONE	REMARKS
ES1	AC CONTACTORS	SIEMENS	RC-IN I S NR DEL AREA, JIL BUILDING, TOWER-B, PLOT NO. 78, SECTOR 18, GURGAON-122015, INDIA	0124-2842000, 9873424331 amit.bhadauria@siemens.com	
	AC CONTACTORS	GE-POWER	KAMAK TOWER, 3RD FLOOR, PLOT NO. 12-A, TVK INDUSTRIAL ESTATE, EKKADUTHANGAL, GUINDY, CHENNAI-600032	044-49681447	
	AC CONTACTORS	TELEMECHANIQUE/ SCHNEIDER ELECTRIC INDIA PVT. LTD.	9TH FLOOR, BLDG. NO. 10, TOWER-C, DLF CYBER CITY, PH-II, GURGAON-122002	0124-3940400	TAKEN OVER BY SCHNEIDER
	AC CONTACTORS	L&T	32, SHIVAJI MARG, P.O. BOX- 6223, NEW DELHI 110015	011-41419554/59	
	AC CONTACTORS	BCH	20/4, MATHURA ROAD, FARIDABAD, HARYANA- 121006	0129-4293000	
ES2	AC LOAD BREAK SWITCH	GE-POWER	KAMAK TOWER, 3RD FLOOR, PLOT NO. 12-A, TVK INDUSTRIAL ESTATE, EKKADUTHANGAL, GUINDY, CHENNAI-600032	044-49681447	
	AC LOAD BREAK SWITCH	L&T	32, SHIVAJI MARG, P.O. BOX- 6223, NEW DELHI 110015	011-41419554/59	
	AC LOAD BREAK SWITCH	SIEMENS	RC-IN I S NR DEL AREA, JIL BUILDING, TOWER-B, PLOT NO. 78, SECTOR 18, GURGAON-122015, INDIA	0124-2842000, 9873424331 amit.bhadauria@siemens.com	
	AC LOAD BREAK SWITCH	KAYCEE	KAYCEE INDUSTRIES LTD., C/O-CMS COMPUTERS LTD., 35A, REAR BLDG., KILOKARI, NEW DELHI-110014	Rajiv Sharma-9312004687	
	AC LOAD BREAK SWITCH	C&S ELECTRIC LTD.	222, OKHLA IND. ESTATE, PH-III, NEW DELHI- 110020	011-3088 7520-29	
ES3	AC MCCB	C&S ELECTRIC LTD.	222, OKHLA IND. ESTATE, PH-III, NEW DELHI- 110020	011-3088 7520-29	
	AC MCCB	SCHNEIDER ELECTRIC INDIA PVT. LTD.	9TH FLOOR, BLDG. NO. 10, TOWER-C, DLF CYBER CITY, PH-II, GURGAON-122002	0124-3940400	
	AC MCCB	SIEMENS	RC-IN I S NR DEL AREA, JIL BUILDING, TOWER-B, PLOT NO. 78, SECTOR 18, GURGAON-122015, INDIA	0124-2842000, 9873424331 amit.bhadauria@siemens.com	
	AC MCCB	GE-POWER	KAMAK TOWER, 3RD FLOOR, PLOT NO. 12-A, TVK INDUSTRIAL ESTATE, EKKADUTHANGAL, GUINDY, CHENNAI-600032	044-49681447	
	AC MCCB	L&T	32, SHIVAJI MARG, P.O. BOX- 6223, NEW DELHI 110015	011-41419554/59	
	AC MCCB	CROMPTON GREAVES	RAIL TRANSPORTATION SYSTEMS,VANDANA BUILDING, 11, TOLSTOY MARG, TOLSTOY MARG, NEW DELHI, DL 110001	011 3041 6300	
ES4	ACDB/ DCDB DRAWOUT TYPE	ELECTRO CONTROLS & DEVICES	M/S ELECTRO CONTROLS & DEVICES, F-41, SITE-C, SURAJPUR INDUSTRIAL AREA GREATER NOIDA UTTAR PRADESH :201308	Mr. Sanjay Sharma (Chief Promoter) 0120-2569487, 2560100,2560300	
	ACDB/ DCDB DRAWOUT TYPE	KMG ATOZ SYSTEMS	C-49, SECTOR-81-NOIDA-201305	120-4207920, 08527897328	
	ACDB/ DCDB DRAWOUT TYPE	ASIATIC	A-58 NARAINA IND. AREA, PHASE-I, NEW DELHI 110028	011 - 25796330, 25796617	
	ACDB/ DCDB DRAWOUT TYPE	UNILEC ENGINEERS PVT. LTD.	BEHRAMPUR INDUSTRIAL AREA, BEGAMPUR KHATOLA ROAD, GURGAON-122001	0124-4030247,248, 4559700, 9911087173	
	ACDB/ DCDB DRAWOUT TYPE	C&S ELECTRIC LTD.	222, OKHLA IND. ESTATE, PH-III, NEW DELHI- 110020	011-3088 7520-29	
	ACDB/ DCDB DRAWOUT TYPE	L&T	32, SHIVAJI MARG, P.O. BOX- 6223, NEW DELHI 110015	011-41419554/59	
	ACDB/ DCDB DRAWOUT TYPE	GE-POWER	KAMAK TOWER, 3RD FLOOR, PLOT NO. 12-A, TVK INDUSTRIAL ESTATE, EKKADUTHANGAL, GUINDY, CHENNAI-600032	044-49681447	
	ACDB/ DCDB DRAWOUT TYPE	SIEMENS	RC-IN I S NR DEL AREA, JIL BUILDING, TOWER-B, PLOT NO. 78, SECTOR 18, GURGAON-122015, INDIA	0124-2842000, 9873424331 amit.bhadauria@siemens.com	
ACDB/ DCDB FIXED TYPE	ELECTRO CONTROLS & DEVICES	M/S ELECTRO CONTROLS & DEVICES, F-41, SITE-C, SURAJPUR INDUSTRIAL AREA GREATER NOIDA UTTAR PRADESH :201309	Mr. Sanjay Sharma (Chief Promoter) 0120-2569487, 2560100,2560300		

ITEM CODE	ITEM/SERVICE DESCRIPTION	VENDOR NAME	ADDRESS	PHONE	REMARKS
ES5	ACDB/ DCDB FIXED TYPE	JASPER ENGINEERS PVT. LTD.	A-23, SECTOR - 8, NOIDA-201301	0120-4033520/533	
	ACDB/ DCDB FIXED TYPE	JACKSON ENGINEERS	A-43, HOSEIRY COMPLEX, OPPOSITE NSEZ, NOIDA-201305	0120-4302600, 2568923,27	
	ACDB/ DCDB FIXED TYPE	SPACEAGE SWITCHGEARS LTD.	68 & 13-A INDUSTRIAL DEVELOPMENT COLONY, MEHRAULI ROAD GURGAON, HARYANA-122001	0124-2302711, 4085091	
	ACDB/ DCDB FIXED TYPE	KMG ATOZ SYSTEMS	C-49, SECTOR-81-NOIDA-201305	120-4207920, 08527897328	
	ACDB/ DCDB FIXED TYPE	ASIATIC	A-58 NARAINA IND. AREA, PHASE-I, NEW DELHI 110028	011 - 25796330, 25796617	
	ACDB/ DCDB FIXED TYPE	UNILEC ENGINEERS PVT. LTD.	BEHRAMPUR INDUSTRIAL AREA, BEGAMPUR KHATOLA ROAD, GURGAON-122001	0124-4030247,248, 4559700, 9911087173	
	ACDB/ DCDB FIXED TYPE	C&S ELECTRIC LTD.	222, OKHLA IND. ESTATE, PH-III, NEW DELHI-110020	011-3088 7520-29	
	ACDB/ DCDB FIXED TYPE	ENPRO ENGG.	NO.995P, DIAMOND PLAZA, 2ND FLOOR, 12TH MAIN ROAD, ANNA NAGAR, CHENNAI-40	044 - 42611526 / 42170338 / 26262716	
	ACDB/ DCDB FIXED TYPE	ASSOCIATED SWGR & PROJ. LTD.	C-10, UPSIDC, INDUSTRIAL AREA, SITE-IV, KASNA ROAD, GREATER NOIDA-201306	0120-4294618,19,20 Asplho@gmail.com	
	ACDB/ DCDB FIXED TYPE	BCH	20/4, MATHURA ROAD, FARIDABAD, HARYANA-121006	0129-4293000	
	ACDB/ DCDB FIXED TYPE	ECS PRIVATE LTD	7/47, Site 2, Upsidc Ind Area, Loni Road, MOHAN Nagar, Ghaziabad, Uttar Pradesh 201007	098 10 217990	
	ACDB/ DCDB FIXED TYPE	L&T	32, SHIVAJI MARG, P.O. BOX- 6223, NEW DELHI 110015	011-41419554/59	
	ACDB/ DCDB FIXED TYPE	GE-POWER	KAMAK TOWER, 3RD FLOOR, PLOT NO. 12-A, TVK INDUSTRIAL ESTATE, EKKADUTHANGAL, GUINDY, CHENNAI-600032	044-49681447	
	ACDB/ DCDB FIXED TYPE	SIEMENS	RC-IN I S NR DEL AREA, JIL BUILDING, TOWER-B, PLOT NO. 78, SECTOR 18, GURGAON-122015, INDIA	0124-2842000, 9873424331 amit.bhadauria@siemens.com	
	ACDB/ DCDB FIXED TYPE	KHOKHAR ELECT. PVT LTD.	C-44, SEC-63, NOIDA-201307	120- 654 5452	
ACDB/ DCDB FIXED TYPE	VIDHYUT CONTROLS (INDIA) PVT. LTD.	M/S VIDHYUT CONTROL (I) PVT.LTD. D-12 & 13, SECTOR-17,KAVI NAGAR INDL AREA,GHAZIABAD – 201002 (DELHI NCR) U.P. INDIA	0120-4186400, 0120-4186423, 8527005590(DK GUPTA)		
ES6	AIR CIRCUIT BREAKER	L&T	32, SHIVAJI MARG, P.O. BOX- 6223, NEW DELHI 110015	011-41419554/59	
	AIR CIRCUIT BREAKER	SIEMENS	RC-IN I S NR DEL AREA, JIL BUILDING, TOWER-B, PLOT NO. 78, SECTOR 18, GURGAON-	0124-2842000, 9873424331 amit.bhadauria@siemens.com	
	AIR CIRCUIT BREAKER	GE-POWER	KAMAK TOWER, 3RD FLOOR, PLOT NO. 12-A, TVK INDUSTRIAL ESTATE, EKKADUTHANGAL, GUINDY, CHENNAI-600032	044-49681447	
	AIR CIRCUIT BREAKER	SCHNEIDER ELECTRIC INDIA PVT. LTD.	9TH FLOOR, BLDG. NO. 10, TOWER-C, DLF CYBER CITY, PH-II, GURGAON-122002	0124-3940400	
	AIR CIRCUIT BREAKER	C&S ELECTRIC LTD.	222, OKHLA IND. ESTATE, PH-III, NEW DELHI-110020	011-3088 7520-29	
ES7	AUXILIARY RELAYS	ABB	14, MATHURA ROAD, FARIDABAD, HARYANA-121003	0129-2567580, 09871799449	
	AUXILIARY RELAYS	ALSTOM LTD	A-7, SEC-65, NOIDA	0120-479 0000	
	AUXILIARY RELAYS	JYOTI LTD.	JYOTI LIMITED, E&CS DIVISION,3/15, BIDC, GORWA,VADODARA - 390 016, E-MAIL ID: ECS@JYOTI.COM	Ph. No.:+91-265-2281214 , Fax No.:+91-265-2281214	
	AUXILIARY RELAYS	OEN INDIA LTD	29/1479, VYTILLA, COCHIN - 682 019 KERALA, INDIA	Phone : +91 484 2301132, 2303709 Fax : +91 484 2302287, 2302221 sales@oenindia.com	
	AUXILIARY RELAYS	SIEMENS	RC-IN I S NR DEL AREA, JIL BUILDING, TOWER-B, PLOT NO. 78, SECTOR 18, GURGAON-122015, INDIA	0124-2842000, 9873424331 amit.bhadauria@siemens.com	
ES8	BIMETAL RELAYS	L&T	32, SHIVAJI MARG, P.O. BOX- 6223, NEW DELHI 110015	011-41419554/59	
	BIMETAL RELAYS	GE-POWER	KAMAK TOWER, 3RD FLOOR, PLOT NO. 12-A, TVK INDUSTRIAL ESTATE, EKKADUTHANGAL, GUINDY, CHENNAI-600032	044-49681447	
	BIMETAL RELAYS	SIEMENS	RC-IN I S NR DEL AREA, JIL BUILDING, TOWER-B, PLOT NO. 78, SECTOR 18, GURGAON-122015, INDIA	0124-2842000, 9873424331 amit.bhadauria@siemens.com	
	BIMETAL RELAYS	TELEMECHANIQUE/ SCHNEIDER ELECTRIC INDIA PVT. LTD.	9TH FLOOR, BLDG. NO. 10, TOWER-C, DLF CYBER CITY, PH-II, GURGAON-122002	0124-3940400	TAKEN OVER BY SCHNEIDER
	BUCHHOLZ RELAY	ALSTOM LTD	A-7, SEC-65, NOIDA	0120-479 0000	

ITEM CODE	ITEM/SERVICE DESCRIPTION	VENDOR NAME	ADDRESS	PHONE	REMARKS
ES9	BUCHHOLZ RELAY	ATVUS INDUSTRIES	689, BLOCK 'O', NEW ALIPORE, CALCUTTA-700053	(91)-(33)-24001101 / 9885 sales@atvus.in	
	BUCHHOLZ RELAY	INSTRUMENTS & CONTROLS	146,GIDC IND.ESTATE,MAKARPURA, VADODRA-390010	0265-2642729	
ES10	CABLE CLAMPS & CABLE TIES	ELECTROMAC IND.CORPN.	27/28 AF,NEW EMPIRE IND.ESTT., R.KRISHNA MANDIR RD.JB NGR ,ANDHERI(E), MUMBAI-400059	91-22-28324829 / 66919034/ Mr. Devang Patel/ 91-9867074600 devang@electromacglands.com	
	CABLE CLAMPS & CABLE TIES	INCAB	HARE STREET,KOLKATA,WEST BENGAL-700001	91-33-2480161/62/63/64 Fax : 91-33-2485766	
	CABLE CLAMPS & CABLE TIES	NOVOFLEX MARKETING PVT. LTD.	RAIKVA' - 5TH FLOOR, UNIT-6 3A, RAM MOHAN MULLICK GARDEN LANE KOLKATA - 700 010	Phone: +91 33 2372 0088 Email: sales@novoflex.co.in, novoflexcal@vsnl.net	
ES11	CABLE GLANDS	ALLIED TRADERS & EXPORTERS	C-124 A, SECTOR-2, NOIDA -201 301, UTTAR PRADESH, INDIA	Mr. Vijay Mohan Sood +(91)-(120)-2525694 +(91)-(120)-3052594 +(91)-(11)-23287156 vijay_mohansood@yahoo.com	
	CABLE GLANDS	ARUP ENGG & FOUNDRY WORKS	391/119,PRINCE ANWAR SHAH ROAD, CALCUTTA-700068	033 2473 0850	
	CABLE GLANDS	BALIGA LIGHTING EQPT.PVT.LTD.	63A,CP RAMASWAMY ROAD, ALWARPET,P.B.No 6910, CHENNAI-600018	44-24995505,22680990-4	
	CABLE GLANDS	COMMET BRASS PRODUCTS	NUTAN CHEMICAL COMPOUND, WALBHAT ROAD, GOREGAON, MUMBAI-400063	91-022-26852961/62/63 comet@vsnl.net	
	CABLE GLANDS	DOWELLS	M/S. DOWELLS ELECTRICALS 47/47A, SATGURU INDUSTRIAL ESTATE. OFF AAREY ROAD, GOREGOAN (EAST). MUMBAI 400 063.	CEO : Mr. Jayantibhai S. Patel TEL: 022-32504770./022-29270876/ 022-29270878.	
	CABLE GLANDS	ELECTROMAC INDUSTRIES	27/28AF NEW EMPIRE IND.ESTT., R.KRISHNA MANDIR RD.JB NGR ,ANDHERI(E),MUMBAI-400059	91-22-28324829 / 66919034 devang@electromacglands.com	
	CABLE GLANDS	INCAB	HARE STREET,KOLKATA,WEST BENGAL-700001	91-33-2480161/62/63/64 Fax : 91-33-2485766	
ES12	CABLE LUGS	DOWELLS	M/S. DOWELLS ELECTRICALS 47/47A, SATGURU INDUSTRIAL ESTATE. OFF AAREY ROAD, GOREGOAN (EAST).	CEO : Mr. Jayantibhai S. Patel TEL: 022-32504770./022-29270876/ 033 2282 2540	
	CABLE LUGS	UNIVERSAL MACHINES LTD.	4,B.B.D.BAG (EAST) 90,STEPHEN HOUSE,5TH FLR CALCUTTA-700001		
ES13	D.C. MCCB	CROMPTON GREAVES	RAIL TRANSPORTATION SYSTEMS,VANDANA BUILDING, 11, TOLSTOY MARG, TOLSTOY MARG, NEW DELHI, DL 110001	011 3041 6300	
	D.C. MCCB	L&T	32, SHIVAJI MARG, P.O. BOX- 6223, NEW DELHI 110015	011-41419554/59	
	D.C. MCCB	GE-POWER	KAMAK TOWER, 3RD FLOOR, PLOT NO. 12-A, TVK INDUSTRIAL ESTATE, EKKADUTHANGAL,	044-49681447	
	D.C. MCCB	SIEMENS	RC-IN I S NR DEL AREA, JIL BUILDING, TOWER-B, PLOT NO. 78, SECTOR 18, GURGAON-122015, INDIA	0124-2842000, 9873424331 amit.bhadauria@siemens.com	
ES14	EARTH LEAKAGE CB	L&T	32, SHIVAJI MARG, P.O. BOX- 6223, NEW DELHI 110015	011-41419554/59	
	EARTH LEAKAGE CB	SIEMENS	RC-IN I S NR DEL AREA, JIL BUILDING, TOWER-B, PLOT NO. 78, SECTOR 18, GURGAON-122015, INDIA	0124-2842000, 9873424331 amit.bhadauria@siemens.com	
	EARTH LEAKAGE CB	GE-POWER	KAMAK TOWER, 3RD FLOOR, PLOT NO. 12-A, TVK INDUSTRIAL ESTATE, EKKADUTHANGAL, GUINDY, CHENNAI-600032	044-49681447	
	EARTH LEAKAGE CB	SCHNEIDER ELECTRIC INDIA PVT. LTD.	9TH FLOOR, BLDG. NO. 10, TOWER-C, DLF CYBER CITY, PH-II, GURGAON-122002	0124-3940400	
	EARTH LEAKAGE CB	C&S ELECTRIC LTD.	222, OKHLA IND. ESTATE, PH-III, NEW DELHI-110020	011-3088 7520-29	
	EARTH LEAKAGE CB	ABB	14, MATHURA ROAD, FARIDABAD, HARYANA-121003	0129-2567580, 09871799449	
	EARTH LEAKAGE CB	INDO ASIAN	B-24, PHASE - II , NOIDA - 201305, U.P.	120-3042222	
	EARTH LEAKAGE CB	MDS SWITCHGEAR LTD	314-317SHAH NAHAR ESTATE NEW NO. 67, OLD NO. 19, DR. RANGA ROAD, MYLAPORE, CHENNAI - 600004	011 - 25793021 044 - 24988056, 044 - 24988057, 044 - 24988058	
ES15	JELLY FILLED CABLES	DELTON SALES LTD.	DELTON HOUSE 4801,BHARAT RAM ROAD,24DARYAGANJ N.DELHI-110002	3273905-8,3262517	
	JELLY FILLED CABLES	HINDUSTAN CABLES	A-40 ASIAN GAMES VILLAGE RANJIT SINGH BLOCK NEW DELHI-110049	011-26493673	
	JELLY FILLED CABLES	TELELINK-NICCO	NICCO HOUSE 2,HARE STREET,CALCUTTA-700001	91-033-66285000	
	JELLY FILLED CABLES	USHA BELTRON LTD.	TATISILWAI , ranchi- 835105	91 651 415 897, 415 816	
ES16	GI CONDUITS		BIS APPROVED MAKE		

ITEM CODE	ITEM/SERVICE DESCRIPTION	VENDOR NAME	ADDRESS	PHONE	REMARKS
ES17	GI CONDUIT (EPOXY PAINTED)	BIS APPROVED MAKE			
ES18	FLEXIBLE CONDUITS (LEAD COATED)	PLICA INDIA PVT. LTD.	V.P.AGARWAL MANAGING DIRECTOR, PLICA INDIA PVT. LTD. 149, MODEL TOWN EAST GHAZIABAD - 201009	M - 9810052131 / 0120-4563979 / 9810557567 Mail: agr@plicaindia.com	
ES19	FLEXIBLE CONDUIT (PVC COATED)	REPUTED MAKE			
ES20	DC CONTACTORS	SCHNEIDER ELECTRIC INDIA PVT. LTD.	9TH FLOOR, BLDG. NO. 10, TOWER-C, DLF CYBER CITY, PH-II, GURGAON-122002	0124-3940400	
	DC CONTACTORS	BHEL (BHOPAL)	HEAVY ELECTRICAL PLANT		
	DC CONTACTORS	ELECTROMAC INDUSTRIES	27/28AF NEW EMPIRE IND.ESTT., R.KRISHNA MANDIR RD.JB NGR ,ANDHERI(E),MUMBAI-400059	91-22-28324829 / 66919034 devang@electromacglands.com	
	DC CONTACTORS	L&T	32, SHIVAJI MARG, P.O. BOX- 6223, NEW DELHI 110015	011-41419554/59	
	DC CONTACTORS	SIEMENS	RC-IN I S NR DEL AREA, JIL BUILDING, TOWER-B, PLOT NO. 78, SECTOR 18, GURGAON-122015, INDIA	0124-2842000, 9873424331 amit.bhadauria@siemens.com	
	DC CONTACTORS	TELEMECHANIQUE/ SCHNEIDER ELECTRIC INDIA PVT. LTD.	9TH FLOOR, BLDG. NO. 10, TOWER-C, DLF CYBER CITY, PH-II, GURGAON-122002	0124-3940400	TAKEN OVER BY SCHNEIDER
	DC CONTACTORS	GE-POWER	KAMAK TOWER, 3RD FLOOR, PLOT NO. 12-A, TVK INDUSTRIAL ESTATE, EKKADUTHANGAL, GUINDY, CHENNAI-600032	044-49681447	
ES21	CONTROL SWITCHES/ SELECTOR SWITCH	KAYCEE	KAYCEE INDUSTRIES LTD., C/O-CMS COMPUTERS LTD., 35A, REAR BLDG., KILOKARI, NEW DELHI-110014	Rajiv Sharma-9312004687	
	CONTROL SWITCHES/ SELECTOR SWITCH	GE-POWER	KAMAK TOWER, 3RD FLOOR, PLOT NO. 12-A, TVK INDUSTRIAL ESTATE, EKKADUTHANGAL, GUINDY, CHENNAI-600032	044-49681447	
	CONTROL SWITCHES/ SELECTOR SWITCH	ALSTOM LTD	A-7, SEC-65, NOIDA	0120-479000	
	CONTROL SWITCHES/ SELECTOR SWITCH	SCHNEIDER ELECTRIC INDIA PVT. LTD.	9TH FLOOR, BLDG. NO. 10, TOWER-C, DLF CYBER CITY, PH-II, GURGAON-122002	0124-3940400	
	CONTROL SWITCHES/ SELECTOR SWITCH	M/s Shrenik & Co.	39A/3, PANCHRATNA INDUSTRIAL ESTATE, SARKHEI-BAVLA ROAD, CHANGODAR,		
CONTROL SWITCHES/ SELECTOR SWITCH	RECOM PVT. LTD.	M/S RECOM PVT. LTD.,16A , 2ND FLOOR A, WING RAJ INDUSTRIAL COMPLEX, MILITARY	Mr. Chandrashekar Kamath (MD) : 09820249503		
ES22	CONTROL TRANSFORMER/ WINDING HEATING TRANSFORMER	AUTOMATIC ELECTRIC LTD.	96 AB LONAVLA INDUSTRIAL ESTATE NANGARGAON, LONAVLA-410401	Phone : +91 2114323665 Fax : +91 2114273482	
	CONTROL TRANSFORMER/ WINDING HEATING TRANSFORMER	INDCOIL	PLOT NO. A- 150/ 151, 23RD U ROAD, WAGLE ESTATE, THANE WEST, CST RD, FRIENDS COLONY, HALLOW PUL, KURLA WEST, MUMBAI, MAHARASHTRA 400070	Phone:022 2583 8305	
	CONTROL TRANSFORMER/ WINDING HEATING TRANSFORMER	KAPPA ELECTRICALS	KAPPA ELECTRICALS, KAPPA CONSOLIDATED PVT. LTD., 14, CART TRACK ROAD, MADUVANKARAI, CHENNAI - 600 042, INDIA.	PHONE: +91 - 44 - 22454709, 22454516, 22450794, 22450795 FAX: +91 - 44 - 22351662, 22451693 E-MAIL: mira@kappaelectricals.com sales@kappaelectricals.com	
	CONTROL TRANSFORMER/ WINDING HEATING TRANSFORMER	LOGICSTAT	B-160, INDUSTRIAL AREA, C BLOCK RD, OKHLA I, OKHLA INDUSTRIAL AREA, NEW DELHI, DL 110020	011 2681 0032	
	CONTROL TRANSFORMER/ WINDING HEATING TRANSFORMER	PRECISE ELECTRICALS	47A-49A,CHAKALA ROAD ANDHERI(E),MUMBAI 99 MUMBAI, MAHARASHTRA, INDIA PIN-400 099	022-8323402 / 022-8216433	
	CONTROL TRANSFORMER/ WINDING HEATING TRANSFORMER	UNILEC ENGINEERS PVT. LTD.	PLOT NO: R-247, T.T.C. INDUSTRIAL AREA, M.I.D.C , RABALE, NAVI MUMBAI- 400 701 INDIA	+91-22- 27607787 / 27607927 +91-22- 27607997	
	CONTROL TRANSFORMER/ WINDING HEATING TRANSFORMER	M/s Newtek Electricals	M-90, M.I.D.C, Waluj, Aurangabad 431136, Maharashtra, India	Tel/Fax: +91 240 2551555 E-mail: mkt.north@newtekelectricals.com , sales@newtekelectricals.com Mr Sanjeev Aggarwal (9958897890)	FOR CONTROL TRANSFORMER ONLY
LT- CURRENT TRANSFORMER	SIEMENS	RC-IN I S NR DEL AREA, JIL BUILDING, TOWER-B, PLOT NO. 78, SECTOR 18, GURGAON-122015, INDIA	0124-2842000, 9873424331 amit.bhadauria@siemens.com		
LT- CURRENT TRANSFORMER	AUTOMATIC ELECTRIC LTD.	96 AB LONAVLA INDUSTRIAL ESTATE NANGARGAON, LONAVLA-410401	Phone : +91 2114323665 Fax : +91 2114273482		

ITEM CODE	ITEM/SERVICE DESCRIPTION	VENDOR NAME	ADDRESS	PHONE	REMARKS
ES23	LT- CURRENT TRANSFORMER	INDCOIL	PLOT NO. A- 150/ 151, 23RD U ROAD, WAGLE ESTATE, THANE WEST, CST RD, FRIENDS COLONY, HALLOW PUL, KURLA WEST, MUMBAI, MAHARASHTRA 400070	Phone:022 2583 8305	
	LT- CURRENT TRANSFORMER	KAPPA ELECTRICALS	KAPPA ELECTRICALS, KAPPA CONSOLIDATED PVT. LTD., SOUTHERN ELECTRIKS 14, CART TRACK ROAD, MADUVANKARAI, CHENNAI - 600 042, INDIA.	PHONE: +91 - 44 - 22454709, 22454516, 22450794, 22450795 FAX: +91 - 44 - 22351662, 22451693 E-MAIL: mira@kappaelectricals.com sales@kappaelectricals.com	
	LT- CURRENT TRANSFORMER	PRAGATI ELECTRICALS	280/3,II POKHRAN RD	5341779,5427041	
	LT- CURRENT TRANSFORMER	PRECISE ELECTRICALS	47A-49A,CHAKALA ROAD ANDHERI(E),MUMBAI 99 MUMBAI, MAHARASHTRA, INDIA PIN-400 099	022-8323402 / 022-8216433	
	LT- CURRENT TRANSFORMER	SILKAANS ELECT.MFG.CO.PVT.LTD	PLOT NO: R-247, T.T.C. INDUSTRIAL AREA, M.I.D.C , RABALE, NAVI MUMBAI- 400 701 INDIA	+91-22- 27607787 / 27607927 +91-22- 27607997	
	LT- CURRENT TRANSFORMER	PRAYOG ELECTRICALS PVT. LTD.	GROUND FLOOR, THAKORE INDUSTRIAL COMPUND, STATION ROAD, VIDYA VIHAR (W), NATHANI ROAD , OPP. AMIBIKA TEMPLE,MUMBAI Mumbai - 400086, Maharashtra, India	91-22-25164288/25133146 Mr. P. U. PATWARDHAN (MANAGING DIRECTOR)	
	LT- CURRENT TRANSFORMER	C&S ELECTRIC LTD.	222, OKHLA IND. ESTATE, PH-III, NEW DELHI-110020	011-3088 7520-29	
	LT- CURRENT TRANSFORMER	M/s Newtek Electricals	M-90, M.I.D.C, Waluj, Aurangabad 431136, Maharashtra, India	Tel/Fax: +91 240 2551555 E-mail: mkt.north@newtekelectricals.com , sales@newtekelectricals.com Mr Sanjeev Aggarwal (9958897890)	
ES24	LT- POTENTIAL TRANSFORMER	SIEMENS	RC-IN I S NR DEL AREA, JIL BUILDING, TOWER-B, PLOT NO. 78, SECTOR 18, GURGAON-122015, INDIA	0124-2842000, 9873424331 amit.bhadauria@siemens.com	
	LT- POTENTIAL TRANSFORMER	AUTOMATIC ELECTRIC LTD.	96 AB LONAVLA INDUSTRIAL ESTATE NANGARGAON, LONAVLA-410401	Phone : +91 2114323665 Fax : +91 2114273482	
	LT- POTENTIAL TRANSFORMER	INDCOIL	PLOT NO. A- 150/ 151, 23RD U ROAD, WAGLE ESTATE, THANE WEST, CST RD, FRIENDS COLONY, HALLOW PUL, KURLA WEST, MUMBAI, MAHARASHTRA 400070	Phone:022 2583 8305	
	LT- POTENTIAL TRANSFORMER	KAPPA ELECTRICALS	KAPPA ELECTRICALS, KAPPA CONSOLIDATED PVT. LTD., SOUTHERN ELECTRIKS 14, CART TRACK ROAD, MADUVANKARAI, CHENNAI - 600 042, INDIA.	PHONE: +91 - 44 - 22454709, 22454516, 22450794, 22450795 FAX: +91 - 44 - 22351662, 22451693 E-MAIL: mira@kappaelectricals.com sales@kappaelectricals.com	
	LT- POTENTIAL TRANSFORMER	PRAGATI ELECTRICALS	280/3,II POKHRAN RD	5341779,5427041	
	LT- POTENTIAL TRANSFORMER	PRECISE ELECTRICALS	47A-49A,CHAKALA ROAD ANDHERI(E),MUMBAI 99 MUMBAI, MAHARASHTRA, INDIA PIN-400 099	022-8323402 / 022-8216433	
	LT- POTENTIAL TRANSFORMER	SILKAANS ELECT.MFG.CO.PVT.LTD	PLOT NO: R-247, T.T.C. INDUSTRIAL AREA, M.I.D.C , RABALE, NAVI MUMBAI- 400 701 INDIA	+91-22- 27607787 / 27607927 +91-22- 27607997	
	LT- POTENTIAL TRANSFORMER	PRAYOG ELECTRICALS PVT. LTD.	GROUND FLOOR, THAKORE INDUSTRIAL COMPUND, STATION ROAD, VIDYA VIHAR (W), NATHANI ROAD , OPP. AMIBIKA TEMPLE,MUMBAI Mumbai - 400086, Maharashtra, India	91-22-25164288/25133146 Mr. P. U. PATWARDHAN (MANAGING DIRECTOR)	
	LT- POTENTIAL TRANSFORMER	M/s Newtek Electricals	M-90, M.I.D.C, Waluj, Aurangabad 431136, Maharashtra, India	Tel/Fax: +91 240 2551555 E-mail: mkt.north@newtekelectricals.com , sales@newtekelectricals.com Mr Sanjeev Aggarwal (9958897890)	
ES25	DC SWITCH	GE-POWER	KAMAK TOWER, 3RD FLOOR, PLOT NO. 12-A, TVK INDUSTRIAL ESTATE, EKKADUTHANGAL, GUINDY, CHENNAI-600032	044-49681447	
	DC SWITCH	KAYCEE	KAYCEE INDUSTRIES LTD., C/O-CMS COMPUTERS LTD., 35A, REAR BLDG., KILOKARI, NEW DELHI-110014	Rajiv Sharma-9312004687	
	DC SWITCH	SIEMENS	RC-IN I S NR DEL AREA, JIL BUILDING, TOWER-B, PLOT NO. 78, SECTOR 18, GURGAON-122015, INDIA	0124-2842000, 9873424331 amit.bhadauria@siemens.com	

ITEM CODE	ITEM/SERVICE DESCRIPTION	VENDOR NAME	ADDRESS	PHONE	REMARKS
ES26	DISTRIBUTION BOX	M/S SHRENIK & CO.	39A/3, PANCHRATNA INDUSTRIAL ESTATE, SARKHEJ-BAVLA ROAD, CHANGODAR, AHMEDABAD – 382 213		
ES27	EMER. PORTABLE LTG. SET	BAJAJ ELECTRICALS	BAJAJ ELECTRICALS LTD. ENGINEERING & PROJECTS BU (NORTH) 3rd FLOOR, GULMOHARHOUSE, COMMUNITY CENTRE 161/B-4, GAUTAM NAGAR, YUSUF SARAI NEW DELHI – 110049	CONTACT PERSON : Mr. S. SREEMANY. SR. MANAGER (PROJECTS) CONTACT DETAILS : (+91) 9871025705. MAIL ID : srbans@bajajelectricals.com;	
	EMER. PORTABLE LTG. SET	BAJAJ ELECTRICALS	BAJAJ ELECTRICALS LTD. ENGINEERING & PROJECTS BU (NORTH) 3rd FLOOR, GULMOHARHOUSE, COMMUNITY CENTRE 161/B-4, GAUTAM NAGAR, YUSUF SARAI NEW DELHI – 110049	SREEMANY. SR. MANAGER (PROJECTS) CONTACT DETAILS : (+91) 9871025705. MAIL ID : srbans@bajajelectricals.com;	
ES28	FUSE BASE	INDO ASIAN	B-24, PHASE - II , NOIDA - 201305, U.P.	120-3042222	
	FUSE BASE	GE-POWER	KAMAK TOWER, 3RD FLOOR, PLOT NO. 12-A, TVK INDUSTRIAL ESTATE, EKKADUTHANGAL, GUINDY, CHENNAI-600032	044-49681447	
	FUSE BASE	L&T	32, SHIVAJI MARG, P.O. BOX- 6223, NEW DELHI 110015	011-41419554/59	
	FUSE BASE	C&S ELECTRIC LTD.	222, OKHLA IND. ESTATE, PH-III, NEW DELHI-110020	011-3088 7520-29	
	FUSE BASE	SIEMENS	RC-IN I S NR DEL AREA, JIL BUILDING, TOWER-B, PLOT NO. 78, SECTOR 18, GURGAON-122015, INDIA	0124-2842000, 9873424331 ;amit.bhadauria@siemens.com	
	FUSE BASE	ABB	14, MATHURA ROAD, FARIDABAD, HARYANA-121003	0129-2567580, 09871799449	
	FUSE BASE	SPACEAGE SWITCHGEARS LTD.	68 & 13-A INDUSTRIAL DEVELOPMENT COLONY, MEHRAULI ROAD GURGAON, HARYANA-122001	0124-2302711, 4085091	
	FUSE BASE	SCHNEIDER ELECTRIC INDIA PVT. LTD.	9TH FLOOR, BLDG. NO. 10, TOWER-C, DLF CYBER CITY, PH-II, GURGAON-122002	0124-3940400	
	FUSE BASE	ALSTOM LTD	A-7, SEC-65, NOIDA	0120-479 0000	
	FUSE BASE	ESSEN DEINKI	FLAT NO. 502, SKYLINE HOUSE 85, NEHRU PLACE NEW DELHI	011-26217060	
ES29	HRC FUSES	INDO ASIAN	B-24, PHASE - II , NOIDA - 201305, U.P.	120-3042222	
	HRC FUSES	GE-POWER	KAMAK TOWER, 3RD FLOOR, PLOT NO. 12-A, TVK INDUSTRIAL ESTATE, EKKADUTHANGAL, GUINDY, CHENNAI-600032	044-49681447	
	HRC FUSES	L&T	32, SHIVAJI MARG, P.O. BOX- 6223, NEW DELHI 110015	011-41419554/59	
	HRC FUSES	C&S ELECTRIC LTD.	222, OKHLA IND. ESTATE, PH-III, NEW DELHI-110020	011-3088 7520-29	
	HRC FUSES	SIEMENS	RC-IN I S NR DEL AREA, JIL BUILDING, TOWER-B, PLOT NO. 78, SECTOR 18, GURGAON-122015, INDIA	0124-2842000, 9873424331 ;amit.bhadauria@siemens.com	
	HRC FUSES	ABB	14, MATHURA ROAD, FARIDABAD, HARYANA-121003	0129-2567580, 09871799449	
	HRC FUSES	SPACEAGE SWITCHGEARS LTD.	68 & 13-A INDUSTRIAL DEVELOPMENT COLONY, MEHRAULI ROAD GURGAON, HARYANA-122001	0124-2302711, 4085091	
	HRC FUSES	SCHNEIDER ELECTRIC INDIA PVT. LTD.	9TH FLOOR, BLDG. NO. 10, TOWER-C, DLF CYBER CITY, PH-II, GURGAON-122002	0124-3940400	
	HRC FUSES	ALSTOM LTD	A-7, SEC-65, NOIDA	0120-479 0000	
	HRC FUSES	ESSEN DEINKI	FLAT NO. 502, SKYLINE HOUSE 85, NEHRU PLACE NEW DELHI	011-26217060	
GALVANISING	GALVANISING	Jenco Industrial Corporation	Chincholi Bunder Khkar Road Near Link Road Devruwadi Malad (W) Mumbai 400064		
	GALVANISING	National Galvanizing Company	66, Barrackpore Kamarhatt Trunck Road Calcutta-700058		
	GALVANISING	Sigma Galvanising Pvt. Ltd.	Plot No.C-169, TTC, MIDC Ind Area Navin Mumbai-400705	8725402,8725765	
	GALVANISING	B.P. Projects PVT LTD	167A, Vivekananda Road Kolkata-700006	033 2553 1254	
	GALVANISING	Standard Galvanisers	Makardah Road, Kabar Para, Bankra, Howarah -711403	28756318/28741986/28725402/28725765	
	GALVANISING	Steel Products	National Highway No. 6, Chamrail, Kona, Howrah-711114		

ITEM CODE	ITEM/SERVICE DESCRIPTION	VENDOR NAME	ADDRESS	PHONE	REMARKS
ES30	GALVANISING	Unitech Fabricators & Engineers Pvt. Ltd.	Village- Ajab Nagar, P.O. -Molla Simla, P.S. - Singur, Dist - Hoogly, Pin-712223	022 -27686606/ 1907	
	GALVANISING	Shivam Engineers & Fabricators	A0-282-284, Industrial Area, South Side of G.T. Road, Ghaziabad, U.P.		
	GALVANISING	B.G. Shirke Construction Technology Pvt. Ltd	72-76, Mundhawa, Pune - 401 036		
	GALVANISING	Galbro Ispat Galvanizers Pvt. Ltd.	GUT 11 AND 12, OPP. Kudus Steel,Rolling Mill, Wada, Thane , Mumbai		
	GALVANISING	Eros Metals	G-97, MIDC, Bhutibori , Nagpur		
	GALVANISING	Industrial Perforation (India) Pvt. Ltd.	Ganganagr, Katakhal, Kolkata-700132		
	GALVANISING	Indmark Formtech Pvt. Ltd.	Phase - 3, E - 11 / 1, M. I. D. C., Chakan, Pune - 410 501, Maharashtra, India.		
	GALVANISING	Namdhari Industrial Traders Pvt. Ltd.	Village Latton Dana, Chandigarh Road, Ludhiana		
	GALVANISING	Neha Galvaniser	Jalan Industrial Estate, Gate No-1, 1st Right Choise Lane, Near N.G-6, Jangalpur, PO Domjur Howrah - 700071, West Bengal, India		
	GALVANISING	Patny Systems (P) Ltd.	Unit-IV, Sy No. -228/9, Plot No. 6, IP Kuchavaram, Toopran(M) Dist.- Medak, Telegana - 502336		
	GALVANISING	Parmar Metal Company	Survey No.207,Veraval (Shapar) Dist. Rajkot, India.		
	GALVANISING	Rukmani Electrical & Components Pvt Ltd	Urla Industrial Area, Urla Sarora Road, Raipur- 493 221 (Chhattisgarh)		
	GALVANISING	Rukmani Fab & Gal Pvt Ltd	Shankharidaha Baniyarah, Jalan Industrial Complex, Gate no.3, Lane no. 4, Domjur, Howrah , W.B. - 711411		
	GALVANISING	DMP Projects Pvt.Ltd.	Dulagarh Industrial Park , PS-Sankrail , Howrah -711302		
	GALVANISING	Vinfab Engineers India Private Limited	Gut no. 224/1 &2 Bhiwandi Wada State Highway, Village khupri, Dist. Thane, Maharashtra -421303		
	GALVANISING	Saral Projects & Processors	B-1, Industrial Area, Site-II, Amawan Road Rae Bareli		
	GALVANISING	Brahampuri Steels Limited	172 (F) Industrial Area, Jhotwara, Jaipur-302013		
	GALVANISING	Indiana Gratings PVT. LTD	F-5, MIDC Jejuri, Pune-412 303		
GALVANISING	M/S AVAIDS TECHNOVATORS PVT. LTD	131, MATSYA INDUSTRIAL AREA, ALWAR RAJASTHAN			
ES31	GI WIRE & FLAT	INDUSTRIAL PERFORATION (I) PVT.LTD.	MR. A. K. SAHA 327, R.N.GUHA ROAD, DUM DUM KOLKATA-West Bengal-India Phone-9830241788 Pincode : 700028 Email : ipipl@cal2.vsnl.net.in	011 2737 3579	
	GI WIRE & FLAT	INDIA ELECTRICALS SYNDICATE	Mr. Suresh Kumar Agarwal 55, Ezra Street, Kolkata-West Bengal-India Phone- 033-22354047 Pincode : 700001 Email : cabletray@vsnl.com	022-28511704	
	GI WIRE & FLAT	INDMARK FORMTECH PVT. LTD.	Mr. Narendra R. Meher J Block, Plot No.-375, MIDC BHOSARI PUNE-MAHARASHTRA-INDIA Phone- 020-27130546 Pincode : 411026 Email : indmarkformtech@vsnl.net		
	GI WIRE & FLAT	PREMIER POWER PRODUCTS (CAL) PVT. LTD.	Chatterjee International Centre, 33A, Jawaharlal Nehru Road, 6th Floor, Suit No. - 11A, Kolkata,-West Bengal-India Phone-9331008739 Pincode : 700071 Email : hemantdaga@dagaventures.com		
	GI WIRE & FLAT	PATNY SYSTEMS (P) LTD	PATNY PLAZA 160 , SARDAR PATEL ROAD SEUNDRABAD SECUNDRABAD-TELANGANA-INDIA Phone- 040-27902451 Pincode : 500003 Email : mr.mkt@patnysystems.com		
	GI WIRE & FLAT	PASSIVE INFRA PROJECTS PVT. LTD.	MR. VARUN AGRAWAL 182, VAISHALI, PITAMPURA Delhi-DELHI-INDIA Phone-9871183059 Pincode : 110088 Email : ATANU.SAHA@PASSIVEINFRA.COM		
	GI WIRE & FLAT	RUKMANI ELECTRICAL & COMPONENTS PVT LTD	11A , MAHARISHI DEBENDRA ROAD 1ST FL , ROOM NO.4 KOLKATA-WEST BENGAL-INDIA Phone- Pincode : 700007 Email : maruthikabra@gmail.com		

ITEM CODE	ITEM/SERVICE DESCRIPTION	VENDOR NAME	ADDRESS	PHONE	REMARKS
	GI WIRE & FLAT	RATAN PROJECTS & ENGINEERING CO. PVT.LTD.	MR. G.D. SINGHEE/MR. MAHESH SINGHEE 26, P.K. TAGORE STREET, MAIN BUILDING KOLKATA-WEST BENGAL-INDIA Phone- 9830177331 Pincode : 700006 Email : mahesh@ratans.com		
	GI WIRE & FLAT	RABI ENGINEERING WORKS PVT. LTD.	MR. TAPAN KUMAR SEN/MR. SIDDHARTHA 327, R.N. GUHA ROAD, DUM DUM, KOLKATA-WEST BENGAL-INDIA Phone- 9748753002 Pincode : 700028 Email : rabiengineering@gmail.com		
	GI WIRE & FLAT	RAJASTHAN METAL SMELTING CO.	Mr. R. K. Tibrewala D-80, Road No. 7, V.K.I.A., Jaipur-Rajasthan-India Phone- 0141-2332269 Pincode : 302013 Email : info@rmscoindia.com		
	GI WIRE & FLAT	SARAL INDUSTRIES	Mr. Y.K. Gupta L-1, L-2, Industrial Area-1 Sultanpur Road Rae Bareilly-Uttar Pradesh-India Phone- 0535-2702474 Pincode : 229010 Email : saralindustries@gmail.com		
	GI WIRE & FLAT	PARCO Engineers Pvt. Ltd.	401, skyline Epitom Building ,Near to Jolly Gym Khana, Kirol Road , Vidhyavihar, MH 400086 India		
	GI WIRE & FLAT	UNITECH FABRICATORS and ENGINEERS PVT LTD	INDRAPRASHTHA APARTMENT 24 , M.B.RAOD , BIRATI KALABAGAN KOLKATA KOLKATA-WEST BENGAL-INDIA Phone- Pincode : 700051 Email : ufepl@vsnl.net; ufepl@rediffmail.com	022 - 26230814	
ES32	HIGH MAST	BAJAJ ELECTRICALS	BAJAJ ELECTRICALS LTD. ENGINEERING & PROJECTS BU (NORTH) 3rd FLOOR, GULMOHARHOUSE, COMMUNITY CENTRE 161/B-4, GAUTAM NAGAR, YUSUF SARAI NEW DELHI – 110049	SREEMANY. SR. MANAGER (PROJECTS) CONTACT DETAILS : (+91) 9871025705. MAIL ID :rabans@bajajelectricals.com;	
	HIGH MAST	M/S TRANSRAIL LIGHTING LIMITED (TLL)	M/S TRANSRAIL LIGHTING LIMITED (TLL), GAMMON INDIA LIMITED 2ND FLOOR , CENTRIC PLAZA, PLOT NO.8 POCKET-4, SECTOR-11 DWARKA , NEW DELHI -110075	hemant.jain@transrailttd.com'	
ES33	IND.POWER & WLDG SOCKETS	CROMPTON GREAVES	3RD FLOOR, EXPRESS BUILDING,9-10, BAHADUR SHAH ZAFAR MARG, NEAR ITO CROSSING,NEW DELHI-110002, INDIA	91 11 23460700 - 999 'Sunil.Das@cgglobal.com	
	IND.POWER & WLDG SOCKETS	CYCLE ELECTRIC DEVICE & SERV.CO.	: A-3, NEAR ANTHEM BIOSCIENCE, KSSIDC INDUSTRIAL AREA, BOMMASANDRA, BOMMASANDRA INDUSTRIAL AREA, BANGALORE, KARNATAKA 560099	Mr. H.Jaishanker +919845039081, 080 - 27833102, 080 - 27833103 : +91 80 41460985 'cycloelectric@gmail.com	
	IND.POWER & WLDG SOCKETS	BCH	20/4, MATHURA ROAD, FARIDABAD - 121006, HARYANA, INDIA	0(129)-4063000, 9015800189(Ramesh Giri) 'ramesh.giri@bchindia.com	
	IND.POWER & WLDG SOCKETS	BEST & CROMPTON	Best & Crompton Engineering Ltd	Ph : +91 44 4551 4724 , MRKT	BEST &
	IND.POWER & WLDG SOCKETS	AJMERA INDUSTRIES & ENGG. WORKS	AJMERA INDL. AND ENGG. WORKS. AJMERA HOUSE, A-61 / KHAIRANE MIDC. , TTC INDL. AREA, NAVI MUMBAI – 400705.	Tel : 022 27620299 / 97 / 96 'mail@ajmerna.net	
ES34	INTERPOSING RELAY	ABB	14, MATHURA ROAD, FARIDABAD, HARYANA-121003	0129-2567580, 09871799449	
	INTERPOSING RELAY	ALSTOM LTD	A-7, SEC-65, NOIDA	0120-479 0000	
	INTERPOSING RELAY	JYOTI LTD.	JYOTI LIMITED, E&CS DIVISION,3/15, BIDC, GORWA,VADODARA - 390 016, E-MAIL ID: ECS@JYOTI.COM	Ph. No.:+91-265-2281214 , Fax No.:+91-265-2281214	
	INTERPOSING RELAY	OEN INDIA LTD	29/1479, VYTILLA, COCHIN - 682 019 KERALA, INDIA	Phone : +91 484 2301132, 2303709 Fax : +91 484 2302287, 2302221 sales@oenindia.com	
	INTERPOSING RELAY	SIEMENS	RC-IN I S NR DEL AREA, JIL BUILDING, TOWER-B, PLOT NO. 78, SECTOR 18, GURGAON-122015, INDIA	0124-2842000, 9873424331 amit.bhadauria@siemens.com	
ES35	INDICATING LAMPS	BCH	20/4, MATHURA ROAD, FARIDABAD, HARYANA-121006	0129-4293000	
	INDICATING LAMPS	C&S ELECTRIC LTD.	222, OKHLA IND. ESTATE, PH-III, NEW DELHI-110020	6832259,6918834-37	
	INDICATING LAMPS	ESSEN DEINKI	FLAT NO. 502, SKYLINE HOUSE 85, NEHRU PLACE NEW DELHI	011-26217060	
	INDICATING LAMPS	VAISHNO(HOTLINE SWGR.& CONTROL)	G-19, SECTOR - 11, NOIDA - 201301, UTTAR PRADESH, INDIA	8377805157 9818338922	
	INDICATING LAMPS	GE-POWER	KAMAK TOWER, 3RD FLOOR, PLOT NO. 12-A, TVK INDUSTRIAL ESTATE, EKKADUTHANGAL, GUINDY, CHENNAI-600032	9818338922	
	INDICATING LAMPS	SIEMENS	RC-IN I S NR DEL AREA, JIL BUILDING, TOWER-B, PLOT NO. 78, SECTOR 18, GURGAON-122015, INDIA	0124-2842000, 9873424331 amit.bhadauria@siemens.com	
	INDICATING LAMPS	SCHNEIDER ELECTRIC INDIA PVT. LTD.	9TH FLOOR, BLDG. NO. 10, TOWER-C, DLF CYBER CITY, PH-II, GURGAON-122002	0124-3940400	

ITEM CODE	ITEM/SERVICE DESCRIPTION	VENDOR NAME	ADDRESS	PHONE	REMARKS
ES36	JUNCTION BOXES (NON FLAME PROOF)	JASPER ENGINEERS PVT. LTD.	A-23, SECTOR - 8, NOIDA-201301	0120-4033520/533	
	JUNCTION BOXES (NON FLAME PROOF)	Electro Controls & Devices	M/S ELECTRO CONTROLS & DEVICES, F-41, SITE-C, SURAJPUR INDUSTRIAL AREA GREATER NOIDA, UTTAR PRADESH :201308	Mr. Sanjay Sharma (Chief Promoter) 0120-2569487, 2560100,2560300	
	JUNCTION BOXES (NON FLAME PROOF)	M/s Shrenik & Co.	39A/3, PANCHRATNA INDUSTRIAL ESTATE, SARKHEJ-BAVLA ROAD, CHANGODAR, AHMEDABAD – 382 213	020-026708100	
	JUNCTION BOXES (NON FLAME PROOF)	M/s PHOENIX MECANO LTD.,	388 BHARE, TALUKA MULSHI, POST GHOTAWADE, PIRANGOOT, INDUSTRIAL AREA, PUNE-412115	Awasthi(09971119006) Tel: ++91 20 6674 5103, Mobile: +91 90499 95985, Fax: ++91 20 6674 5126	
	JUNCTION BOXES (NON FLAME PROOF)	Adroit Control Engineers Pvt.Ltd.	M/S ADROIT CONTROL ENGINEERS PVT.LTD. PLOT-3, KRISHNA INDL. AREA, SECTOR-25 FARIDABAD – 121004	011-47600700, 0129-4251400	
	JUNCTION BOXES (NON FLAME PROOF)	M/s PHOENIX MECANO LTD.,	388 BHARE, TALUKA MULSHI, POST GHOTAWADE, PIRANGOOT, INDUSTRIAL AREA, PUNE-412115	Awasthi(09971119006) Tel: ++91 20 6674 5103, Mobile: +91 90499 95985, Fax: ++91 20 6674 5126 contact person : Vishwa bandhu E-mail:d.gupta@pmipl-online.com ;admin@pmipl-online.com	
	JUNCTION BOXES (NON FLAME PROOF)	MIKA ENGINEERS	BRANCH OFFICE : 'D'-101, DHEERAJ HERITAGE RESIDENCY II, SHASTRI NAGAR, SANTACRUZ (W), MUMBAI 400 054.	Director : Mr. Asgar Karimi Email: asgar@mikaengineers.com E-mail : mika@mtnl.net.inTelfax : 022-26610081/82/83/84Tel : 02527-249066/70 Cell : 099230 74373	TYPE-S ONLY
	JUNCTION BOXES (NON FLAME PROOF)	M/s PHOENIX MECANO LTD.,	388 BHARE, TALUKA MULSHI, POST GHOTAWADE, PIRANGOOT, INDUSTRIAL AREA, PUNE-412115	TEL.- +912066745000 Awasthi(09971119006) Tel: ++91 20 6674 5103, Mobile: +91 90499 95985, Fax: ++91 20 6674 5126 contact person : Vishwa bandhu E-mail:d.gupta@pmipl-online.com ;admin@pmipl-online.com	
	JUNCTION BOXES (NON FLAME PROOF)	BAJAJ ELECTRICALS	BAJAJ ELECTRICALS LTD. ENGINEERING & PROJECTS BU (NORTH) 3rd FLOOR, GULMOHARHOUSE, COMMUNITY CENTRE 161/B-4, GAUTAM NAGAR, YUSUF SARAI NEW DELHI – 110049	CONTACT PERSON : Mr. S. SREEMANY. SR. MANAGER (PROJECTS) CONTACT DETAILS : (+91) 9871025705. MAIL ID : srbans@bajajelectricals.com;	
	JUNCTION BOXES (NON FLAME PROOF)	AJMERA INDUSTRIES & ENGG. WORKS	AJMERA INDL. AND ENGG. WORKS. AJMERA HOUSE, A-61 / KHAIRANE MIDC. , TTC INDL. AREA, NAVI MUMBAI – 400705.	Tel : 022 27620299 / 97 / 96 'mail@ajmera.net	
	JUNCTION BOXES (NON FLAME PROOF)	S.B. ELECTRICAL ENGINEERING CORPORATION	03, SARDAR GRIHA BUILDING, LOHAR CHAWAL, MUMBAI-400002	022- 22069831; 022-66637259	
	JUNCTION BOXES (NON FLAME PROOF)	RITTAL INDIA PVT. LTD.	Espire Building ,Level -1 A-41, Mohan Co-Operative Industrial Estate ,Mathura Road, New Delhi -110044	Amit Bansal Phone: 011-42004000, D: 011-42004033 - Mobile: +91 9717772245 - mailto:amit.b@rittal-india.com www.rittal-india.com	
JUNCTION BOXES (NON FLAME PROOF)	HPL ELECTRIC AND POWER LTD.	Works Address: Village Shavella, PO:Jabli, Teh- Kasauli, Dist-Solan, Himachal Pradesh-173209	Mr. Ashwani Kumar mailto:'ashwani@hplindia.com' M:9971127370		
ES37	JUNCTION BOXES (FLAME PROOF)	SUDHIR SWITCHGEAR	305/6, APEEJAY HOUSE, 130, BOMBAY SAMACHAR MARG, MUMBAI - 400 023. INDIA	Telephone Nos. : 40460000 (100 lines) Fax Nos. : ++-91-22-22049381 Email : md@sudhirswitchgears.com ; works@sudhirswitchgears.com ; scud@vsnl.com	

ITEM CODE	ITEM/SERVICE DESCRIPTION	VENDOR NAME	ADDRESS	PHONE	REMARKS
ES47	LOCAL PUSH BUTTON STATION (NON FLAME PROOF)	GE-POWER	KAMAK TOWER, 3RD FLOOR, PLOT NO. 12-A, TVK INDUSTRIAL ESTATE, EKKADUTHANGAL, GUINDY, CHENNAI-600032	044-49681447	
	LOCAL PUSH BUTTON STATION (NON FLAME PROOF)	ASIATIC	A-58 NARAINA IND. AREA, PHASE-I, NEW DELHI 110028	011 - 25796330, 25796617	
	LOCAL PUSH BUTTON STATION (NON FLAME PROOF)	C&S ELECTRIC LTD.	222, OKHLA IND. ESTATE, PH-III, NEW DELHI-110020	011 - 25793021	
	LOCAL PUSH BUTTON STATION (NON FLAME PROOF)	EVERGREEN ENGG. CO.	EVERGREEN ENGG COMPANY WORKS-5, PLOT NO. 9,10,11,12, SURVEY NO. 242, CHINCH PADA, VASAI EAST-401208	(0250) 6458250	
	LOCAL PUSH BUTTON STATION (NON FLAME PROOF)	TECKNIC CONTROLS	703, MADHAVA, BANDRA, KURLA COMPLEX, BANDRA EAST, MUMBAI, MAHARASHTRA 400051	022-42532507/00 022-24451648	
	LOCAL PUSH BUTTON STATION (NON FLAME PROOF)	EX-PROTECTA LIGHTING EQUIPMENT	305-306, GIDC ESTATE, VITHAL UDYOGNAGAR - 388121 DIST. ANAND, GUJARAT 388121 INDIA	02692-237823	
	LOCAL PUSH BUTTON STATION (NON FLAME PROOF)	BALIGA ELECTRICALS	63A,CP RAMASWAMY ROAD, PB NO 6910, CHENNAI-600018	44-24995505,22680990-4	
	LOCAL PUSH BUTTON STATION (NON FLAME PROOF)	ENPRO ENGG.	NO.995P, DIAMOND PLAZA, 2ND FLOOR, 12TH MAIN ROAD, ANNA NAGAR, CHENNAI-40	044 - 42611526 / 42170338 / 26262716 enproengg@enproengineering.com	
	LOCAL PUSH BUTTON STATION (NON FLAME PROOF)	STERLING SWGR CONTROL PVT.LTD.	P.O. BOX NO. 17023, SORAB HOUSE, 2ND FLOOR, 555, S.B. MARG, DADAR, MUMBAI - 400028, MAHARASHTRA, INDIA	91-22-24222297/24222298/24224236	
	LOCAL PUSH BUTTON STATION (NON FLAME PROOF)	ELEXPRO ELECTRICALS PVT/ LTD.	C 1/27 & 37 GIDC KABILPORE NAVSARI-396424	02637-265140, Mr. Jssk kumar	
	LOCAL PUSH BUTTON STATION (NON FLAME PROOF)	VAISHNO(HOTLINE SWGR & CONTROL)	G-19, SECTOR - 11, NOIDA - 201301, UTTAR PRADESH, INDIA	8377805157 9818338922	
	LOCAL PUSH BUTTON STATION (NON FLAME PROOF)	JASPER ENGINEERS PVT. LTD.	A-23, SECTOR - 8, NOIDA-201301	0120-4033520/533	
	LOCAL PUSH BUTTON STATION (NON FLAME PROOF)	KMG ATOZ SYSTEMS	C-49, SECTOR-81-NOIDA-201305	120-4207920, 08527897328	
	LOCAL PUSH BUTTON STATION (NON FLAME PROOF)	UNILEC ENGINEERS PVT. LTD.	BEHRAMPUR INDUSTRIAL AREA, BEGAMPUR KHATOLA ROAD, GURGAON-122001	0124-4030247,248, 4559700, 9911087173	
	LOCAL PUSH BUTTON STATION (NON FLAME PROOF)	BCH	20/4, MATHURA ROAD, FARIDABAD, HARYANA-121006	0129-4293000	
	LOCAL PUSH BUTTON STATION (NON FLAME PROOF)	CANDS	J/202, ANSA INDUSTRIAL ESTATE, SAKI VIHAR ROAD, SAKINAKA, ANDHERI (EAST), MUMBAI-72	022-28570858	
	LOCAL PUSH BUTTON STATION (NON FLAME PROOF)	SIEMENS	RC-IN I S NR DEL AREA, JIL BUILDING, TOWER-B, PLOT NO. 78, SECTOR 18, GURGAON-122015, INDIA	0124-2842000, 9873424331 amit.bhadauria@siemens.com	
	LOCAL PUSH BUTTON STATION (NON FLAME PROOF)	SCHNEIDER ELECTRIC INDIA PVT. LTD.	9TH FLOOR, BLDG. NO. 10, TOWER-C, DLF CYBER CITY, PH-II, GURGAON-122002	0124-3940400	
LOCAL PUSH BUTTON STATION (NON FLAME PROOF)	TECKNIC CONTROLS	703, MADHAVA, BANDRA, KURLA COMPLEX, BANDRA EAST, MUMBAI, MAHARASHTRA 400051	022-42532507/00 022-24451648		
LOCAL PUSH BUTTON STATION (NON FLAME PROOF)	UNITED ELECTRIC	97 UDYOG VIHAR PHASE-I, GURGAON 122015, HARYANA	124 4002970 72		
LOCAL PUSH BUTTON STATION (NON FLAME PROOF)	M/s Shrenik & Co.	39A/3, PANCHRATNA INDUSTRIAL ESTATE, SARKHEI-BAVLA ROAD, CHANGODAR, AHMEDABAD - 382 213			
ES48	LOCAL PUSH BUTTON STATION (FLAME PROOF)				
ES51	MCB	MDS SWITCHGEAR LTD	314-317SHAH NAHAR ESTATE	011 - 25793021	
	MCB	INDO ASIAN	B-24, PHASE - II, NOIDA - 201305, U.P.	120-3042222	
	MCB	SCHNEIDER ELECTRIC INDIA PVT. LTD.	9TH FLOOR, BLDG. NO. 10, TOWER-C, DLF CYBER CITY, PH-II, GURGAON-122002	0124-3940400	
	MCB	S&S POWER SWITCHGEAR LTD,	NEW NO. 67, OLD NO. 19, DR. RANGA ROAD, MYLAPORE, CHENNAI - 600004	044 - 24988056, 044 - 24988057, 044 - 24988058	
ES52	MCC (FIXED TYPE)	SPACEAGE SWITCHGEARS LTD.	68 & 13-A INDUSTRIAL DEVELOPMENT COLONY, MEHRAULI ROAD GURGAON, HARYANA-122001	0124-2302711, 4085091	
	MCC (FIXED TYPE)	ASSOCIATED SWGR & PROJ.LTD.	C-10, UPSIDC, INDUSTRIAL AREA, SITE-IV, KASNA ROAD, GREATER NOIDA-201306	0120-4294618,19,20 Asplho@gmail.com	
	MCC (FIXED TYPE)	BCH	20/4, MATHURA ROAD, FARIDABAD, HARYANA-121006	0129-4293000	
LV MOTORS (NON FLAME PROOF)	ABB		14, MATHURA ROAD, FARIDABAD, HARYANA-121003	0129-2567580, 09871799449	
	BHARAT BIJLEE LTD.		BHARAT BIJLEE LIMITED, 1ST FLOOR, 7-B, RAJINDRA PARK, PUSA ROAD, NEW DELHI - 110 060.	Tel.: + 91 (11) 25816931-33, 35 & 36 DT: +91 25724318 Fax: + 91 (11) 25819640 M:+ 91	

ITEM CODE	ITEM/SERVICE DESCRIPTION	VENDOR NAME	ADDRESS	PHONE	REMARKS
ES53	LV MOTORS (NON FLAME PROOF)	CROMPTON GREAVES	3RD FLOOR, EXPRESS BUILDING,9-10, BAHADUR SHAH ZAFAR MARG, NEAR ITO CROSSING,NEW DELHI-110002, INDIA	91 11 23460700 - 999 Sunil.Das@cgglobal.com	
	LV MOTORS (NON FLAME PROOF)	GE-POWER	KAMAK TOWER, 3RD FLOOR, PLOT NO. 12-A, TVK INDUSTRIAL ESTATE, EKKADUTHANGAL, GUINDY, CHENNAI-600032	044-49681447	
	LV MOTORS (NON FLAME PROOF)	KIRLOSKAR ELECTRIC CO LTD.	P.O. BOX 5555 , MALLESWARAM WEST ,BANGALORE 560055	Tel: +91-80-23374865 Fax: +91-80-23377706	
	LV MOTORS (NON FLAME PROOF)	LAXMI HYDRAULICS PVT. LTD	129/130, INDUSTRIAL ESTATE PATIL NAGAR, HOTGI ROAD SOLAPUR-413003, MAHARASHTRA	0217- 2357001-005	APPROVED UPTO 200KW
	LV MOTORS (NON FLAME PROOF)	MARATHON	MARATHON ELECTRIC INDIA PRIVATE LTD.SECTOR - 11, MODEL TOWN, FARIDABAD - 121006	Ph: +91-129-2286421, 2265340, 4006601 to 4006610	
	LV MOTORS (NON FLAME PROOF)	NGEF	POCKET NO.10, FLAT NO. 37 & 38, EXPANDABLE DDA FLATS, NASIRPUR DWARKA,	Ph: (011) 2539 7763	
	LV MOTORS (NON FLAME PROOF)	RAJINDRA ELECT INDUSTRIES	14 SHAH IND.ESTATE VEERA DESAI RD,ANDHERI(W) MUMBAI-400053	91-22-26730823, 26730789; 91)-(22)-26730154	
LV MOTORS (NON FLAME PROOF)	SIEMENS	RC-IN I S NR DEL AREA, JIL BUILDING, TOWER-B, PLOT NO. 78, SECTOR 18, GURGAON-122015, INDIA	0124-2842000, 9873424331 amit.bhadauria@siemens.com		
ES54	LV MOTORS (FLAME PROOF)	RAJINDRA ELECT INDUSTRIES	14 SHAH IND.ESTATE VEERA DESAI RD,ANDHERI(W) MUMBAI-400053	91-22-26730823, 26730789; 91)-(22)-26730154	
ES55	MODULAR SWITCH BOARD	ANCHOR	STEEL HOUSE, B WING, PLOT NO. 24, MAHAL INDUSTRIAL ESTATE, MAHAKALI CAVES ROAD, NEAR PAPER BOX, ANDHERI (E), MUMBAI, MAHARASHTRA. - 400093	022-30418888.	
	MODULAR SWITCH BOARD	ELEXPRO ELECTRICALS PVT/ LTD.	C 1/27 & 37 GIDC KABILPORE NAVSARI-396424	02637-265140, Mr. Jssk kumar	
	MODULAR SWITCH BOARD	HAVELLS INDIA LIMITED	QRG TOWERS , 2D SECTOR-126, NOIDA-201301	GIRISH KUMAR SHRIVASTAVA +91-9810528922	
ES56	OIL TEMP INDICATOR	PERFECT CONTROLS	BLOCK NO. 7, NORTH ROAD,WEST C.I.T. NAGAR,CHENNAI - 600035, INDIA.	Phone: (91-44) 24341043, 24330387, 42867651 Fax: (91-44) 24345075	
	OIL TEMP INDICATOR	PRECIMEASURE	M/S. PRECIMEASURE CONTROLS PVT. LTD. 168/C, INDUSTRIAL SUBURB, PEENYA 3RD PHASE, BANGALORE - 560058. KARNATAKA, INDIA	Phone EPABX: +91-80-42602702. Fax: +91-80-41552205 E-mail: info@precimeasure.com	
ES57	PROTECTION - RELAYS (PNEUMATIC)	SIEMENS	RC-IN I S NR DEL AREA, JIL BUILDING, TOWER-B, PLOT NO. 78, SECTOR 18, GURGAON-122015, INDIA	0124-2842000, 9873424331 amit.bhadauria@siemens.com	
	PROTECTION - RELAYS (PNEUMATIC)	SCHNEIDER ELECTRIC INDIA PVT. LTD.	9TH FLOOR, BLDG. NO. 10, TOWER-C, DLF CYBER CITY, PH-II, GURGAON-122002	0124-3940400	
	PROTECTION - RELAYS (PNEUMATIC)	GE-MULTILINE, GE INDIA INDUSTRIAL PVT. LTD.	NO. 90- B, ELECTRONICS CITY, HOSUR ROAD, BENGALURU - 560016, KARNATAKA	(080) 41314617, 9945478935	
	PROTECTION - RELAYS (PNEUMATIC)	SCHWEITZER ENGG. LAB (SEL)	406, BHIKAJI CAMA BHAVAN, BHIKAJI CAMA PLACE, BHIKAJI CAMA PLACE, MOHAMMADPUR, RK PURAM, NEW DELHI, DL 110066	011 4152 7899	
	PROTECTION - RELAYS (PNEUMATIC)	C&S ELECTRIC LTD.	222, OKHLA IND. ESTATE, PH-III, NEW DELHI-110020	011-3088 7520-29	
	PROTECTION - RELAYS (PNEUMATIC)	ALSTOM LTD	A-7, SEC-65, NOIDA	0120-479 0000	
	PROTECTION - RELAYS (PNEUMATIC)	ABB	14, MATHURA ROAD, FARIDABAD, HARYANA-121003	0129-2567580, 09871799449	
	PROTECTION - RELAYS (PNEUMATIC)	AVK-SEG & CONTROLS(I) LTD	C-60,NOIDA PHASE-II	6918834-37	
ES58	PROTECTION - RELAYS (NUMERICAL)	SIEMENS	RC-IN I S NR DEL AREA, JIL BUILDING, TOWER-B, PLOT NO. 78, SECTOR 18, GURGAON-122015, INDIA	0124-2842000, 9873424331 amit.bhadauria@siemens.com	
	PROTECTION - RELAYS (NUMERICAL)	SCHNEIDER ELECTRIC INDIA PVT. LTD.	9TH FLOOR, BLDG. NO. 10, TOWER-C, DLF CYBER CITY, PH-II, GURGAON-122002	0124-3940400	
	PROTECTION - RELAYS (NUMERICAL)	GE-MULTILINE, GE INDIA INDUSTRIAL PVT. LTD.	NO. 90- B, ELECTRONICS CITY, HOSUR ROAD, BENGALURU - 560016, KARNATAKA	(080) 41314617, 9945478935	
	PROTECTION - RELAYS (NUMERICAL)	SCHWEITZER ENGG. LAB (SEL)	406, BHIKAJI CAMA BHAVAN, BHIKAJI CAMA PLACE, BHIKAJI CAMA PLACE, MOHAMMADPUR, RK PURAM, NEW DELHI, DL 110066	011 4152 7899	
	RECEPTACLES - DECORATIVE	ANCHOR	STEEL HOUSE, B WING, PLOT NO. 24, MAHAL INDUSTRIAL ESTATE, MAHAKALI CAVES ROAD, NEAR PAPER BOX, ANDHERI (E), MUMBAI, MAHARASHTRA. - 400093	022-30418888.	
	RECEPTACLES - DECORATIVE	ELEXPRO ELECTRICALS PVT/ LTD.	C 1/27 & 37 GIDC KABILPORE NAVSARI-396424	02637-265140, Mr. Jssk kumar	

ITEM CODE	ITEM/SERVICE DESCRIPTION	VENDOR NAME	ADDRESS	PHONE	REMARKS
ES59	RECEPTACLES - DECORATIVE	BAJAJ ELECTRICALS	BAJAJ ELECTRICALS LTD. ENGINEERING & PROJECTS BU (NORTH) 3rd FLOOR, GULMOHARHOUSE, COMMUNITY CENTRE 161/B-4, GAUTAM NAGAR, YUSUF SARAI NEW DELHI – 110049	CONTACT PERSON : Mr. S. SREEMANY. SR. MANAGER (PROJECTS) CONTACT DETAILS : (+91) 9871025705. MAIL ID : srabans@bajajelectricals.com;	
	RECEPTACLES - DECORATIVE	AJMERA INDUSTRIES & ENGG. WORKS	AJMERA INDL. AND ENGG. WORKS. AJMERA HOUSE, A-61 / KHAIRANE MIDC. , TTC INDL. AREA, NAVI MUMBAI – 400705.	Tel : 022 27620299 / 97 / 96 'mail@ajmerna.net	
ES60	RESISTOR FOR DC STARTERS	BCH	20/4, MATHURA ROAD, FARIDABAD, HARYANA-121006	0129-4293000	
	RESISTOR FOR DC STARTERS	C&S ELECTRIC LTD.	222, OKHLA IND. ESTATE, PH-III, NEW DELHI-110020	011-3088 7520-29	
	RESISTOR FOR DC STARTERS	RSI	60,IND.DEV.COLONY, MEHRAULI ROAD, GURGAON-122001	91 - 124 - 2333442	
	RESISTOR FOR DC STARTERS	SPEED-O-CONTROL	C-16, NAND JYOT INDUSTRIAL ESTATE, SAFED POOL, ANDHERI-KURLA ROAD, SAFED POOL, MAGAN NATHURAM RD, SHIVAJI NAGAR, SAKINAKA, MUMBAI, MAHARASHTRA 400072	022 2851 8514	
	RESISTOR FOR DC STARTERS	SUSHIL ENGG CORP.	D-7, GHATKOPAR INDUSTRIAL ESTATE, OFF LBS MARG, GHATKOPAR (WEST), AMRUT NAGAR RD, AMRUT NAGAR, GHATKOPAR WEST, MUMBAI, MAHARASHTRA 400086	022 2500 7976	
ES61	SWITCH BOX	ANCHOR	STEEL HOUSE, B WING, PLOT NO. 24, MAHAL INDUSTRIAL ESTATE, MAHAKALI CAVES ROAD, NEAR PAPER BOX, ANDHERI (E), MUMBAI, MAHARASHTRA.- 400093	022-30418888.	
	SWITCH BOX	ELEXPRO ELECTRICALS PVT/ LTD.	C 1/27 & 37 GIDC KABILPORE NAVSARI-396424	02637-265140, Mr. Jssk kumar	
	SWITCH BOX	BAJAJ ELECTRICALS	BAJAJ ELECTRICALS LTD. ENGINEERING & PROJECTS BU (NORTH) 3rd FLOOR, GULMOHARHOUSE, COMMUNITY CENTRE 161/B-4, GAUTAM NAGAR, YUSUF SARAI NEW DELHI – 110049	CONTACT PERSON : Mr. S. SREEMANY. SR. MANAGER (PROJECTS) CONTACT DETAILS : (+91) 9871025705. MAIL ID : srabans@bajajelectricals.com;	
	SWITCH BOX	AJMERA INDUSTRIES & ENGG. WORKS	AJMERA INDL. AND ENGG. WORKS. AJMERA HOUSE, A-61 / KHAIRANE MIDC. , TTC INDL. AREA, NAVI MUMBAI – 400705.	Tel : 022 27620299 / 97 / 96 'mail@ajmerna.net	
	SWITCH BOX	S.B. ELECTRICAL ENGINEERING CORPORATION	03, SARDAR GRIHA BUILDING, LOHAR CHAWAL, MUMBAI-400002	022- 22069831; 022-66637259	
ES62	TERMINAL BLOCKS	WAGO-CONTROLS	C 27, GREATER NOIDA, SECTOR 58, C BLOCK, SECTOR 58, NOIDA, UTTAR PRADESH 201307	0120-2580409/10	
	TERMINAL BLOCKS	CONNECT WELL	309A/4, 3RD FLOOR, KALKAJI, OKHLA IND AREA PH-2, GOVINDPURI, NEW DELHI, DL 110019	9811881085 09871419996 011-65908877	
	TERMINAL BLOCKS	ELMEX CONTROLS PVT. LTD.	12,G.I.D.C.ESTATE,MUKARPURA ROAD,VADODARA-390010	9374631074	
	TERMINAL BLOCKS	ESSEN DEINKI	FLAT NO. 502, SKYLINE HOUSE 85, NEHRU PLACE NEW DELHI	011-26217060	
	TERMINAL BLOCKS	TECHNOPLAST	OPP.I.M.INTER COLLEGE, BEGUM SARAI KHURD ROAD, AMROHA - 244221, U.P.	PH:- 05922 264006 CELL NO:- 9012676000, 9319520799, 9319582467	
	TERMINAL BLOCKS	M/s PHOENIX MECANO LTD.,	388 BHARE, TALUKA MULSHI, POST GHOTAWADE, PIRANGOOT, INDUSTRIAL AREA, PUNE-412115	TEL.- +912066745000 Awasthi(09971119006) Tel: ++91 20 6674 5103, Mobile: +91 90499 95985, Fax: ++91 20 6674 5126 contact person : Vishwa bandhu E-mail:d.gupta@pmipl-online.com ;admin@pmipl-online.com	
	TERMINAL BLOCKS	ESSEN DEINKI	FLAT NO. 502, SKYLINE HOUSE 85, NEHRU PLACE NEW DELHI	011-26217060	
TIMERS - PNEUMATIC	BCH	20/4, MATHURA ROAD, FARIDABAD, HARYANA-121006	0129-4293000		
TIMERS - PNEUMATIC	ALSTOM LTD	A-7, SEC-65, NOIDA	0120-479 0000		
TIMERS - PNEUMATIC	L&T	32, SHIVAJI MARG, P.O. BOX- 6223, NEW DELHI-110015	011-41419554/59		

ITEM CODE	ITEM/SERVICE DESCRIPTION	VENDOR NAME	ADDRESS	PHONE	REMARKS
ES63	TIMERS - PNEUMATIC	TELEMECHANIQUE/ SCHNEIDER ELECTRIC INDIA PVT. LTD.	9TH FLOOR, BLDG. NO. 10, TOWER-C, DLF CYBER CITY, PH-II, GURGAON-122002	0124-3940400	TAKEN OVER BY SCHNEIDER
	TIMERS - PNEUMATIC	SCHNEIDER ELECTRIC INDIA PVT. LTD.	9TH FLOOR, BLDG. NO. 10, TOWER-C, DLF CYBER CITY, PH-II, GURGAON-122002	0124-3940400	
	TIMERS - PNEUMATIC	ELECTRONIC AUTOMATION PVT. LTD.	20, KHB INDUSTRIAL AREA YELAHANKA BANGLORE-560064	080 -28567561 / 080 -28567562 / 080 -42802345	
ES64	TIMERS - ELECTRONIC	ESSEN DEINKI	FLAT NO. 502, SKYLINE HOUSE 85, NEHRU PLACE NEW DELHI	011-26217060	
ES65	TRANSDUCERS	AUTOMATIC ELECTRIC LTD.	ADDRESS : 96 AB LONAVLA INDUSTRIAL ESTATE	Phone : +91 2114323665 Fax : +91 2114273482	
	TRANSDUCERS	SOUTHERN TRANSDUCERS	INTERTECH B-83, FLATTED FACTORY COMPLEX, NEAR MODI MILLS, OKHLA, NEW DELHI-110020	Mr. Gurmohit Singh 011-41020365 / 9891402128	
ES66	WINDING TEMP INDICATOR	PERFECT CONTROLS	OFFICE ADDRESS: 7, NORTH ROAD, WEST C.I.T. NAGAR, CHENNAI - 600035, INDIA.	Phone: (91-44) 24341043, 24330387, 42867651; Fax: (91-44) 24345075	
	WINDING TEMP INDICATOR	PRECIMEASURE	M/S. PRECIMEASURE CONTROLS PVT. LTD. 168/C, INDUSTRIAL SUBURB, PEENYA 3RD PHASE, BANGALORE - 560058. KARNATAKA, INDIA	Phone EPABX: +91-80-42602702. Fax: +91-80-41552205 E-mail: info@precimeasure.com	
ES72	ENERGY METER (ANALOG)	BHEL (EDN)	MYSORE ROAD, BANGALORE-560026	080-26998500	
	ENERGY METER (ANALOG)	SIMCO ENGG. LTD	NO. 126, K ROAD, TIRUCHIRAPPALLI -620001, TAMIL NADU	Mr. Madaswamy Muthu +(91)-(431)-4046223 +(91)-(431)-4046210 +(91)-9786600915	
	ENERGY METER (ANALOG)	RISHABH INST.PVT LTD	RISHABH INSTRUMENTS PVT. LTD. F-31, MIDC, SATPUR NASHIK - 422007 MAHARASHTRA INDIA	marketing@rishabh.co.in 91-253 2202202/203 Fax: 91 253 2351064	
	ENERGY METER (ANALOG)	AUTOMATIC ELECTRIC LTD.	96 AB LONAVLA INDUSTRIAL ESTATE NANGARGAON, LONAVLA-410401	Phone : +91 2114323665 Fax : +91 2114273482	
	ENERGY METER (ANALOG)	CONZERVE SYSTEMS PVT. LTD.(SCHNEIDER)	87, 1ST FLOOR INDUSTRIAL DEVELOPMENT COLONY (IDC) MEHRAULI ROAD, UGURGAON 122001 HARYANA, INDIA.	4268899, 9910695701	
ES73	ENERGY METER (DIGITAL)	CONZERVE SYSTEMS PVT. LTD.(SCHNEIDER)	87, 1ST FLOOR INDUSTRIAL DEVELOPMENT COLONY (IDC) MEHRAULI ROAD, UGURGAON 122001 HARYANA, INDIA.	4268899, 9910695701	
	ENERGY METER (DIGITAL)	M/s Newtek Electricals	M-90, M.I.D.C, Waluj, Aurangabad 431136, Maharashtra, India	Tel/Fax: +91 240 2551555 E-mail: mkt.north@newtekelectricals.com , sales@newtekelectricals.com Mr Sanjeev Aggarwal (9958897890)	
ES74	AMMETER	AUTOMATIC ELECTRIC LTD.	96 AB LONAVLA INDUSTRIAL ESTATE NANGARGAON, LONAVLA-410401	Phone : +91 2114323665 Fax : +91 2114273482	
	AMMETER	RISHABH INST.PVT LTD	RISHABH INSTRUMENTS PVT. LTD. F-31, MIDC, SATPUR NASHIK - 422007 MAHARASHTRA INDIA	marketing@rishabh.co.in 91-253 2202202/203 Fax: 91 253 2351064	
	AMMETER	M/s Newtek Electricals	M-90, M.I.D.C, Waluj, Aurangabad 431136, Maharashtra, India	Tel/Fax: +91 240 2551555 E-mail: mkt.north@newtekelectricals.com , sales@newtekelectricals.com Mr Sanjeev Aggarwal (9958897890)	
ES75	VOLTMETER	AUTOMATIC ELECTRIC LTD.	96 AB LONAVLA INDUSTRIAL ESTATE NANGARGAON, LONAVLA-410401	Phone : +91 2114323665 Fax : +91 2114273482	
		RISHABH INST.PVT LTD	RISHABH INSTRUMENTS PVT. LTD. F-31, MIDC, SATPUR NASHIK - 422007 MAHARASHTRA INDIA	marketing@rishabh.co.in 91-253 2202202/203 Fax: 91 253 2351064	
	VOLTMETER	M/s Newtek Electricals	M-90, M.I.D.C, Waluj, Aurangabad 431136, Maharashtra, India	Tel/Fax: +91 240 2551555 E-mail: mkt.north@newtekelectricals.com , sales@newtekelectricals.com Mr Sanjeev Aggarwal (9958897890)	
ES76	MPCB	SCHNEIDER ELECTRIC INDIA PVT. LTD.	9TH FLOOR, BLDG. NO. 10, TOWER-C, DLF CYBER CITY, PH-II, GURGAON-122002	0124-3940400	
	MPCB	L&T	32, SHIVAJI MARG, P.O. BOX- 6223, NEW DELHI 110015	011-41419554/59	
	MPCB	SIEMENS	RC-IN I S NR DEL AREA, JIL BUILDING, TOWER- B, PLOT NO. 78, SECTOR 18, GURGAON- 122015, INDIA	0124-2842000, 9873424331 amit.bhadauria@siemens.com	
	MPCB	GE-POWER	KAMAK TOWER, 3RD FLOOR, PLOT NO. 12-A, TVK INDUSTRIAL ESTATE, EKKADUTHANGAL, GUINDY, CHENNAI-600032	044-49681447	

ITEM CODE	ITEM/SERVICE DESCRIPTION	VENDOR NAME	ADDRESS	PHONE	REMARKS
	MPCB	SCHNEIDER ELECTRIC INDIA PVT. LTD.	9TH FLOOR, BLDG. NO. 10, TOWER-C, DLF CYBER CITY, PH-II, GURGAON-122002	0124-3940400	
	MPCB	C&S ELECTRIC LTD.	222, OKHLA IND. ESTATE, PH-III, NEW DELHI-110020	011-3088 7520-29	
ES77	MAGNETIC OIL GAUGE	SUKRUT UDYOG	9/1/A, ERANDAWANE, OPPOSITE MEHENDALE GARAGE, ERANDAWANE, GULAWANI MAHARAJ RD, SWAROOP SOCIETY, VAKIL NAGAR, ERANDAWANE, PUNE, MAHARASHTRA 411004	020 2544 1726	
ES78	MULTIFUNCTION METER	CONZERVE SYSTEMS PVT. LTD./ SCHNEIDER ELECTRIC INDIA PVT. LTD.	87, 1ST FLOOR INDUSTRIAL DEVELOPMENT COLONY (IDC) MEHRAULI ROAD, GURGAON 122001 HARYANA, INDIA.	4268899, 9910695701	TAKEN OVER BY SCHNEIDER
	MULTIFUNCTION METER	M/s Newtek Electricals	M-90, M.I.D.C, Waluj, Aurangabad 431136, Maharashtra, India	Tel/Fax: +91 240 2551555 E-mail: mkt.north@newtekelectricals.com , sales@newtekelectricals.com Mr Sanjeev Aggarwal (9958897890)	
ES79	RCCB	C&S ELECTRIC LTD.	222, OKHLA IND. ESTATE, PH-III, NEW DELHI-110020	011-3088 7520-29	
	RCCB	SCHNEIDER ELECTRIC INDIA PVT. LTD.	9TH FLOOR, BLDG. NO. 10, TOWER-C, DLF CYBER CITY, PH-II, GURGAON-122002	0124-3940400	
	RCCB	SIEMENS	RC-IN I S NR DEL AREA, JIL BUILDING, TOWER-B, PLOT NO. 78, SECTOR 18, GURGAON-122015, INDIA	0124-2842000, 9873424331 amit.bhadauria@siemens.com	
	RCCB	GE-POWER	KAMAK TOWER, 3RD FLOOR, PLOT NO. 12-A, TVK INDUSTRIAL ESTATE, EKKADUTHANGAL, GUINDY, CHENNAI-600032	044-49681447	
	RCCB	L&T	32, SHIVAJI MARG, P.O. BOX- 6223, NEW DELHI 110015	011-41419554/59	
	RCCB	CROMPTON GREAVES	RAIL TRANSPORTATION SYSTEMS,VANDANA BUILDING, 11, TOLSTOY MARG, TOLSTOY MARG, NEW DELHI, DL 110001	011 3041 6300	
ES80	PVC WIRES		BIS APPROVED MAKE		

		MANUFACTURER/ BIDDER/ SUPPLIER NAME & ADDRESS			STANDARD QUALITY PLAN				SPEC NO.: -PE-TS-XXX-508-E002		DATE:-			
		CUSTOMER						QP NO.: -PE-QP-999-508-E003, REV.01		DATE:- 14/06/2020				
		PROJECT						P.O NO.:-		DATE:-				
		ITEM:- BATTERY CHARGER(SCR BASED)		SYSTEM:- DC SYSTEM		SECTION:-		SHEET 1 OF 9						
SL. NO.	COMPONENT & OPERATIONS	CHARACTERISTIC CHECK	CLASS	TYPE OF CHECK	QUANTUM OF CHECK		REFERENCE DOCUMENT	ACCEPTANCE NORMS	FORMAT OF RECORD		AGENCY		REMARKS	
1	2	3	4	5	6	7	8	9	D *	10			11	
					M	C/N					**			
											M	C	N	
1.0	RAW MATERIAL													
1.1	M.S Sheet (CRCA)	1) Grade	MA	Chemical/ Mechanical	100%	-	IS-513	Manufacturer's Drg.	Manufacturer's TC		P	-	-	
		2. Thickness & Finish	MA	Physical	1 Sample/lot	1 Sample/lot	Approved drg/ doc	Approved drg/ doc	Inspection Report	✓	P	V	V	
1.2	Powder Paint	Shade	MA	Visual	1 Sample/lot	-	Shade Card(IS-5)	Approved drg/ doc	-do-		P	-	-	
2.0	MAJOR BOUGHT OUT ITEMS(Note: Make of Bought Items shall be as per Approved List of Makes)													
2.1	Power Switches,MCCB, Timer, Contactor & Relay	1) Type, Rating	MA	Visual	100%	100%	Approved drg/ doc	Approved drg/ doc	Manufacturer's TC	✓	P	V	V	
		2) Mechanical Operation/ Functional check	MA	Visual	100%	-	Manufacturer's std.	Manufacturer's std.	-do-		P	-	-	
2.2	MCCB,Push Buttons,HRC fuse, Terminal blocks, control & selector switches, Semiconductor Fuses, Heaters, Thermostat,Lamps, Plug in socket, Exhaust Fans, Heat Sink	1) Type, Rating	MA	Visual	100%	-	Approved drg/ doc	Approved drg/ doc	-do-		P	-	-	
		2) Continuity test	MA	Electrical	100%	-	Manufacturer's std.	Manufacturer's std.	-do-		P	-	-	
2.3	Rectifier Bridge Element	1) Type, Rating	MA	Visual	100%	100%	Approved drg/ doc	Approved drg/ doc	Manufacturer's TC	✓	P	V	V	
2.4	Digital Multi Function Meters	1) Type, Rating	MA	Visual	100%	100%	Approved drg/ doc	Approved drg/ doc	Manufacturer's TC	✓	P	V	V	
		2) Calibration Certificate	MA	Visual	100%	100%	-do-	-do-	-do-	✓	V	V	V	
		3) Routine TC	MA	Electrical	100%	100%	-do-	-do-	-do-	✓	V	V	V	
2.5	PVC Insulated Electric Cable	1) Type, size	MA	Visual	100%	At Random	Approved drg/ doc	Approved drg/ doc	Inspection Report	✓	P	V	V	All power cables to conform to IS 1554; Control wires to conform to IS 694
		2) I.R Test	MA	Electrical	1 Sample/lot	-	-do-	-do-	-do-		P	-	-	
		3) H.V Test	MA	Electrical	1 Sample/lot	-	-do-	-do-	-do-		P	-	-	
2.6	Transducer	1) Routine TC & Calibration report	MA	Electrical	100%	100%	IS-14570/Approved drg/ doc	IS-14570/Approved drg/ doc	Manufacturer's TC	✓	P	V	V	
		1) Type, Rating	MA	Visual	100%	100%	-do-	-do-	-do-	✓	P	V	V	

BHEL				BIDDER/SUPPLIER		FOR CUSTOMER REVIEW & APPROVAL			
ENGINEERING		QUALITY		Sign & Date		Doc No.		Seal	
Prepared By	Sign & Date	Name	Prepared By	Sign & Date	Name	Reviewed By	Sign & Date	Name	Seal
Checked By		Manish Shukla	Checked By		Ritesh K Jaiswal	Checked By			

KANHAIY A KUMAR
Digitally signed by KANHAIYA KUMAR
DN: cn=KANHAIYA KUMAR, o=BHEL, ou=PEM, email=kanhaiya.kumar@bhel.in, c=IN
Date: 2020.08.28 12:43:46 +05'30'

MANISH
Digitally signed by MANISH
DN: cn=MANISH, o=BHEL, ou=PEM, email=manishshukla@bhel.in, c=IN
Date: 2020.08.28 14:49:59 +05'30'

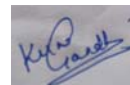

Digitally signed by Kunal
DN: cn=Kunal, o, ou, email=kunalgandhi@bhel.in, c=IN
Date: 2020.08.28 15:04:32 +05'30'

RITESH KUMAR JAISWAL
Digitally signed by RITESH KUMAR JAISWAL
DN: cn=R, ou=BHEL Heavy Electronics Ltd, ou=BHEL / PS-PEM, postalCode=201301, st=Uttar Pradesh, 2.2.5.2.20=160920815239787846a18c5cd0bb18977512609b5149a8b7191a6e51174, serialNumber=8c6d4001b4875a8603a11b000e93f02030462c2c50e4d5f9a9980e09ec448, cn=RITESH KUMAR JAISWAL
Date: 2020.08.28 16:15:13 +05'30'

SL. NO.		COMPONENT & OPERATIONS	CHARACTERISTIC CHECK	CLASS	TYPE OF CHECK	QUANTUM OF CHECK	REFERENCE DOCUMENT	ACCEPTANCE NORMS	FORMAT OF RECORD	AGENCY	REMARKS				
1		2	3	4	5	6	7	8	9	D *	10	11			
						M	C/N				**				
										M	C	N			
		MANUFACTURER/ BIDDER/ SUPPLIER NAME & ADDRESS 													
		CUSTOMER					SPEC NO.:-PE-TS-XXX-508-E002					DATE:-			
		PROJECT					QP NO.:-PE-QP-999-508-E003, REV.01					DATE:- 14/06/2020			
		ITEM:- BATTERY CHARGER(SCR BASED)					SYSTEM:- DC SYSTEM					DATE:-			
							SECTION:-					SHEET 2 OF 9			
2.7		Current Transformer, Voltage Transformer, Dimmerstat Control Transformer	1) Routine Tests	MA	Electrical	100%	10%	IS-2705/ Approved drg/ doc	IS-2705/ Approved drg/ doc	Manufacturer's TC	√	P	V	V	
			2) Type, Rating	MA	Visual	100%	10%	-do-	-do-	-do-	√	P	V	V	
2.8		Busbar	1) Dimensional check	MA	Physical	100%	-	Approved drg/ doc	Approved drg/ doc	Inspection Report		P	-	-	
			2) Conductivity test	MA	Electrical	1 Sample/lot	-	-do-	-do-	-do-		P	-	-	
			3) Surface Finish	MA	Visual	100%	-	-do-	-do-	-do-		P	-	-	
			4) Material Grade	MA	Chemical	1 Sample/lot	-	-do-	-do-	Manufacturer's TC		V	-	-	
2.9		Annunciation facia (if applicable)	All routine test as per EEUA-45D	MA	Electrical	100%	100%	Approved drg/ doc	Approved drg/ doc	Manufacturer's TC	√	P	V	V	
2.10		Visual Indications for charger status using LED/indicating lamps (if annunciation facia is not used)	1) Visual	MA	Visual	100%	100%	Approved drg/ doc	Approved drg/ doc	Inspection Report	√	P	V	V	If Electronic Cards used for indication (Refer Electronic Card Assembly and Location at cl. No. 3.4, for checks)
2.11		Rectifier Transformer	1) Rating	MA	Visual	100%	100%	Approved drg/ doc	Approved drg/ doc	Inspection Report	√	P	V	V	
			2) Dimensional check	MA	Physical	100%	100%	Manufacturer's Drg.	Manufacturer's Drg.	-do-	√	P	V	V	
			a) Overall size	MA	Physical	100%	100%	-do-	-do-	-do-	√	P	V	V	
			b) Mounting Details	MA	Physical	100%	100%	-do-	-do-	-do-	√	P	V	V	
			3) Terminal Board	MA	Physical	100%	100%	-do-	-do-	-do-	√	P	V	V	
			4) Polarity Test	MA	Electrical	100%	100%	-do-	-do-	-do-	√	P	V	V	
			5) I.R Test	MA	Electrical	100%	100%	-do-	-do-	-do-	√	P	V	V	
			6) Routine Tests												
			a)Voltage Ratio Test	MA	Electrical	100%	100%	IEC-60146/ Approved drg/ doc	IEC-60146/ Approved drg/ doc	Manufacturer's TC /Inspection Report	√	P/V	V	V	
			b) DC resistance Test	MA	Electrical	100%	100%	-do-	-do-	-do-	√	P/V	V	V	

BHEL					BIDDER/SUPPLIER		FOR CUSTOMER REVIEW & APPROVAL							
ENGINEERING			QUALITY		Sign & Date		Doc No.		Sign & Date		Name		Seal	
Prepared By	Sign & Date	Kanhaiya Kumar	Prepared By	Sign & Date	Kunal Gandhi	Seal	Reviewed By	Sign & Date	Name	Seal				
Checked By	Manish Shukla	Checked By	Ritesh K Jaiswal	Checked By			Checked By							

KANHAIYA KUMAR
Digitally signed by KANHAIYA KUMAR
DN: cn=KANHAIYA KUMAR, o=BHEL, ou=PEM, email=kanhaiya.kumar@bhel.in, c=IN
Date: 2020.08.28 12:44:18 +05'30'

MANISH
Digitally signed by MANISH
DN: cn=MANISH, o=BHEL, ou=PEM, email=manishshukla@bhel.in, c=IN
Date: 2020.08.28 14:50:25 +05'30'

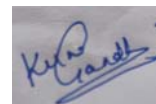

Digitally signed by Kunal
DN: cn=Kunal, o=, ou=, email=kunalgandhi@bhel.in, c=IN
Date: 2020.08.28 15:04:53 +05'30'

RITESH KUMAR JAISWAL

Digitally signed by RITESH KUMAR JAISWAL
DN: cn=IN, o=Bharat Heavy Electricals Ltd, ou=BHEL / PS-PEM, postalCode=201301, st=Uttar Pradesh, 25.420+16692a281523bf78b6a8e18c5cd0bb18977532609b5349ae8d7191a9e51174, serialNumber=8cfaddf001b4875a8b03a31b00e93ff20530462c550e6d5f9d9980e09bc448, cn=RITESH KUMAR JAISWAL
Date: 2020.08.28 16:16:01 +05'30'

SL. NO.		COMPONENT & OPERATIONS	CHARACTERISTIC CHECK	CLASS	TYPE OF CHECK	QUANTUM OF CHECK	REFERENCE DOCUMENT	ACCEPTANCE NORMS	FORMAT OF RECORD	AGENCY	REMARKS				
1	2	3	4	5	6	7	8	9	D*	10	11				
										M	C	N			
					M	C/N				**					
			c) No Load Test Measurement of iron losses	MA	Electrical	100%	100%	IEC-60146/ Approved drg/ doc	IEC-60146/ Approved drg/ doc	Manufacturer's TC /Inspection Report	✓	P/V	V	V	
			d) Measurement of Tap Voltages	MA	Electrical	100%	100%	-do-	-do-	-do-	✓	P/V	V	V	
			e) Measurement of Cu.Losses	MA	Electrical	100%	100%	-do-	-do-	-do-	✓	P/V	V	V	
			f) High voltage test	MA	Electrical	100%	100%	-do-	-do-	-do-	✓	P/V	V	V	
			g) Induced high voltage test	MA	Electrical	100%	100%	-do-	-do-	-do-	✓	P/V	V	V	
			h) Heat run Test	MA	Electrical	100%	100%	-do-	-do-	-do-	✓	P/V	V	V	Insulation Class F with Temp. rise limited to class B insulation value
2.12	Choke		1) Rating	MA	Physical	100%	100%	Approved drg/ doc	Approved drg/ doc	Inspection Report	✓	P	V	V	
			2) Dimensional check	MA	Physical	100%	100%	Manufacturer's Drg.	Manufacturer's Drg.	-do-	✓	P	V	V	
			a) Overall size	MA	Physical	100%	100%	-do-	-do-	-do-	✓	P	V	V	
			b) Mounting Details	MA	Physical	100%	100%	-do-	-do-	-do-	✓	P	V	V	
			3) Terminal Board/ Bakelite plate or busbar	MA	Physical	100%	100%	-do-	-do-	-do-	✓	P	V	V	
			4) Terminal rating	MA	Physical	100%	100%	-do-	-do-	-do-	✓	P	V	V	
			5) Air gap Measurement	MA	Physical	100%	100%	-do-	-do-	-do-	✓	P	V	V	
			6) Contuinity test	MA	Electrical	100%	100%	-do-	-do-	-do-	✓	P	V	V	
			7) Insulation Resistance	MA	Electrical	100%	100%	IEC-60146/ Approved drg/ doc	IEC-60146/ Approved drg/ doc	Manufacturer's TC /Inspection Report	✓	P/V	V	V	
			8) High voltage test	MA	Electrical	100%	100%	-do-	-do-	-do-	✓	P/V	V	V	
			9) DC resistance Test	MA	Electrical	100%	100%	-do-	-do-	-do-	✓	P/V	V	V	
			10) Heat run Test	MA	Electrical	100%	100%	-do-	-do-	-do-	✓	P/V	V	V	Insulation Class F with Temp. rise limited to class B insulation value

BHEL				BIDDER/SUPPLIER		FOR CUSTOMER REVIEW & APPROVAL			
ENGINEERING		QUALITY		Sign & Date		Doc No.	Sign & Date	Name	Seal
Prepared By	Sign & Date	Name	Prepared By	Sign & Date	Name	Reviewed By			
Checked By		Manish Shukla	Checked By		Ritesh K Jaiswal	Checked By			

KANHAIYA KUMAR
Digitally signed by KANHAIYA KUMAR
DN: cn=KANHAIYA KUMAR, o=BHEL, ou=PEM, email=kanhaiya.kumar@bhel.in, c=IN
Date: 2020.08.28 12:44:47 +05'30'

MANISH

Digitally signed by MANISH
DN: cn=MANISH, o=BHEL, ou=PEM, email=manishshukla@bhel.in, c=IN
Date: 2020.08.28 14:50:51 +05'30'

Kunal Gandhi

Digitally signed by Kunal
DN: cn=Kunal, o=ou, email=kunalgandhi@bhel.in, c=IN
Date: 2020.08.28 15:07:28 +05'30'

RITESH KUMAR JAISWAL

Digitally signed by RITESH KUMAR JAISWAL
DN: cn=IN, o=Barat Heavy Electricals Ltd, ou=BHEL / PS-PEM, postalCode=201301, st=Uttar Pradesh, 25.4.2016692281523b78b46a8e18c5cd0bb18977532609b5349a8d7191a9e51174, serialNumber=8cfadd001b4875a8b03a31b000e93f20530462c550e45f99900e090c446, c=IN
Date: 2020.08.28 16:16:50 +05'30'

		MANUFACTURER/ BIDDER/ SUPPLIER NAME & ADDRESS			STANDARD QUALITY PLAN			SPEC NO.: -PE-TS-XXX-508-E002		DATE:-			
		CUSTOMER			PROJECT			QP NO.: -PE-QP-999-508-E003, REV.01		DATE:- 14/06/2020			
		ITEM:- BATTERY CHARGER(SCR BASED)			SYSTEM:- DC SYSTEM			P.O NO.:-		DATE:-			
								SECTION:-		SHEET 4 OF 9			
SL. NO.	COMPONENT & OPERATIONS	CHARACTERISTIC CHECK	CLASS	TYPE OF CHECK	QUANTUM OF CHECK		REFERENCE DOCUMENT	ACCEPTANCE NORMS	FORMAT OF RECORD		AGENCY	REMARKS	
					6		7	8	9	D *	10	11	
					M	C/N					**		
											M	C	N
2.13	Printed Circuit Boards	1) Visual Checks	MA	Physical	100%	-	Manufacturer Drg.	Manufacturer Drg.	Manufacturer's TC		P	-	-
		2) Compliance Report	MA	Physical	100%	-	-do-	-do-	-do-		P	-	-
2.14	Insulating Materials (FRP,SMC,DMC,ETC.)	1) Electrical	CR	Electrical	Sample	Sample	Manufacturer Std.	Manufacturer Std.	Manufacturer's TC	✓	P	V	V
		2) Mech Props.	MA	Mechanical	Sample	-	-do-	-do-	-do-		P	-	-
		3) Tracking Index	MA	Electrical	Sample	-	-do-	-do-	-do-		P	-	-
2.15	Paints	1) Shelf Life	MA	Visual	100%	-	As per Paints Manufacturer Spec	As per Paints Manufacturer Spec	Manufacturer's TC		V	-	-
2.16	Gaskets (Syn. Rubber only)	1) Dimension	MA	Measurement	Sample	-	Manufacturer Drg.	Manufacturer Drg.	Inspection Report		P	-	-
		2) Shore Hardness	MA	Physical	Sample	-	-do-	-do-	-do-		P	-	-
		3) Ageing	MA	Chemical	Sample	-	IS-3400/BS-2752	IS-3400/BS-2752	Manufacturer's TC		P	-	-
3.0	IN PROCESS INSPECTION												
3.1	Enclosure Fabrication	1) Dimensional checks	MA	Physical	100%	-	Manufacturer Fabrication Drg.	Manufacturer Fabrication Drg.	In-process Insp. Report		P	-	-
		2) Diagonal (Skewness)	MA	Physical	100%	-	-do-	-do-	-do-		P	-	-
		3) Straightness	MA	Physical	100%	-	-do-	-do-	-do-		P	-	-
		4) Welded joints	MA	Visual	100%	-	-do-	-do-	-do-		P	-	-
		5) Deburring & Finishing of welded joints	MA	Visual	100%	-	-do-	-do-	-do-		P	-	-
3.2	Pre-Treatment of Enclosure	1) Degreasing	MA	Physical	100%	-	IS-6005/ Manufacturer Std. practice	IS-6005/ Manufacturer Std. practice	In-process Insp. Report		P	-	-
		2) Water rinsing	MA	Physical	100%	-	-do-	-do-	-do-		P	-	-
		3) Derusting	MA	Physical	100%	-	-do-	-do-	-do-		P	-	-
		4) Water rinsing	MA	Physical	100%	-	-do-	-do-	-do-		P	-	-
		5) Phosphating	MA	Physical	100%	-	-do-	-do-	-do-		P	-	-
		6) Water rinsing	MA	Physical	100%	-	-do-	-do-	-do-		P	-	-
		7) Hot- Chromating	MA	Physical	100%	-	-do-	-do-	-do-		P	-	-
		8) Sealing (If used)	MA	Physical	100%	-	-do-	-do-	-do-		P	-	-

BHEL					BIDDER/SUPPLIER		FOR CUSTOMER REVIEW & APPROVAL			
ENGINEERING			QUALITY		Sign & Date	Seal	Doc No.	Sign & Date	Name	Seal
Prepared By	Sign & Date	Name	Prepared By	Sign & Date						
Checked By		Kanhaiya Kumar	Checked By		Kunal Gandhi	Checked By				
		Manish Shukla			Ritesh K Jaiswal					

KANHAIYA KUMAR
 Digitally signed by KANHAIYA KUMAR
 DN: cn=KANHAIYA KUMAR, o=BHEL, ou=PEM,
 email=kanhaiya.kumar@bhel.in, c=IN
 Date: 2020.08.28 12:45:14 +05'30'

MANISH

Digitally signed by MANISH
 DN: cn=MANISH, o=BHEL, ou=PEM,
 email=manishshukla@bhel.in, c=IN
 Date: 2020.08.28 14:51:20 +05'30'



Digitally signed by Kunal
 DN: cn=Kunal, o=ou,
 email=kunalgandhi@bhel.in, c=IN
 Date: 2020.08.28 15:07:45 +05'30'

RITESH KUMAR JAISWAL

Digitally signed by RITESH KUMAR JAISWAL
 DN: cn=IN, o=Bharat Heavy Electricals Ltd,
 ou=BHEL / P&PEM, postalCode=201301,
 st=Uttar Pradesh,
 2.5.4.20=16692a29152307f86a8e18c5d9b
 818077252400965349ed027191d651174,
 serialNumber=Rctadfd001b48758803a31b0
 00e2f022530402c6505ed5f9d9980e096c44
 & cn=RITESH KUMAR JAISWAL
 Date: 2020.08.28 16:17:28 +05'30'

SL. NO.		COMPONENT & OPERATIONS	CHARACTERISTIC CHECK	CLASS	TYPE OF CHECK	QUANTUM OF CHECK	REFERENCE DOCUMENT	ACCEPTANCE NORMS	FORMAT OF RECORD	AGENCY	REMARKS			
1		2	3	4	5	6	7	8	9	D *	10	11		
						M	C/N				M	C	N	
			5) Contuinity	MA	Electrical	100%	-	Manufacturer Drg.	Manufacturer Drg.	In-process Insp. Report	P	-	-	
			6) Identification labels	MA	Visual	100%	-	-do-	-do-	-do-	P	-	-	
3.7	Finishing of Equipment	1) Proper pasting of gasket	MA	Visual	100%	-	Manufacturer Drg.	Manufacturer Drg.	Manufacturer Drg.	In-process Insp. Report	P	-	-	
			2) Earthing busbar	MA	Physical	100%	-	-do-	-do-	-do-	P	-	-	
4.0		FINAL INSPECTION												
4.1	Overall	1) Dimensional & sheet thickness	MA	Physical	100%	Random	Approved drg/ doc	Approved drg/ doc	Inspection Report	✓	P	W	W	
			2) Gen arrangement & Bill of Material(BOM)	MA	Visual	100%	100%	-do-	-do-	-do-	✓	P	W	W
			3) Aesthetic,skewness, Straightness,Door alignment, Labels etc.	MA	Visual	100%	Random	-do-	-do-	-do-	✓	P	W	W
			4) Provision of lifting arrangement	MA	Visual	100%	100%	-do-	-do-	-do-	✓	P	W	W
			5) Proper earthing	MA	Visual	100%	Random	-do-	-do-	-do-	✓	P	W	W
			6) Gasketing (Check with 1mm wire)	MA	Visual	100%	Random	-do-	-do-	-do-	✓	P	W	W
			7) Gland plate arrangement	MA	Visual	100%	Random	-do-	-do-	-do-	✓	P	W	W
			8) Mounting arrangement	MA	Visual	100%	Random	-do-	-do-	-do-	✓	P	W	W
			9) Wiring quality	MA	Visual	100%	Random	-do-	-do-	-do-	✓	P	W	W
			10) Paint shade, Adhesion & thickness check	MA	Visual	100%	Random	Approved drg/ doc & Shade Card(IS-5)	Approved drg/ doc & Shade Card(IS-5)	-do-	✓	P	W	W
			11) Door Functioning	MA	Operation	100%	Random	Approved drg/ doc	Approved drg/ doc	-do-	✓	P	W	W
			12) Mounting & Proper Fixing of components	MA	Visual	100%	Random	-do-	-do-	-do-	✓	P	W	W
			13) Smooth operation of Switches, Pushbutton etc.	MA	Operation	100%	Random	-do-	-do-	-do-	✓	P	W	W
			14) Alarm & Protection	CR	Elect	100%	Random	-do-	-do-	-do-	✓	P	W	W

BHEL				BIDDER/SUPPLIER		FOR CUSTOMER REVIEW & APPROVAL			
ENGINEERING		QUALITY		Sign & Date		Doc No.		Seal	
Sign & Date	Name	Sign & Date	Name	Sign & Date	Name	Sign & Date	Name	Sign & Date	Name
Prepared By	Kanhaiya Kumar	Prepared By	Kunal Gandhi	Seal		Reviewed By			
Checked By	Manish Shukla	Checked By	Ritesh K Jaiswal			Checked By			

KANHAIYA KUMAR
Digitally signed by KANHAIYA KUMAR
DN: cn=KANHAIYA KUMAR, o=BHEL, ou=PEM,
email=kanhaiya.kumar@bhel.in, c=IN
Date: 2020.08.28 12:46:47 +05'30'

MANISH

Digitally signed by MANISH
DN: cn=MANISH, o=BHEL, ou=PEM,
email=manishshukla@bhel.in, c=IN
Date: 2020.08.28 14:52:12 +05'30'

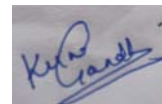

Digitally signed by Kunal
DN: cn=Kunal, o, ou,
email=kunalgandhi@bhel.in,
c=IN
Date: 2020.08.28 15:08:48
+05'30'

RITESH KUMAR JAISWAL

Digitally signed by RITESH KUMAR JAISWAL
DN: cn=IN, o=Bharat Heavy Electricals Ltd,
ou=BHEL / P5-PEM, postalCode=201301,
st=Uttar Pradesh,
2.5.4.20=16692a281523b78b46a8e18c5cd
0bb189775326095349ae8d719149e5117
4,
serialNumber=8cfaddf001b4875a8b03a31
b000e93ff20530462c050e0d59f9980e09
b2c46, cn=RITESH KUMAR JAISWAL,
Date: 2020.08.28 16:19:01 +05'30'



MANUFACTURER/ BIDDER/ SUPPLIER NAME & ADDRESS		STANDARD QUALITY PLAN				SPEC NO.: -PE-TS-XXX-508-E002		DATE:-		
		CUSTOMER				QP NO.: -PE-QP-999-508-E003, REV.01		DATE:- 14/06/2020		
		PROJECT				P.O NO.:-		DATE:-		
		ITEM:- BATTERY CHARGER(SCR BASED)		SYSTEM:- DC SYSTEM		SECTION:-		SHEET 7 OF 9		

SL. NO.	COMPONENT & OPERATIONS	CHARACTERISTIC CHECK	CLASS	TYPE OF CHECK	QUANTUM OF CHECK		REFERENCE DOCUMENT	ACCEPTANCE NORMS	FORMAT OF RECORD		AGENCY			REMARKS
					6	7			8	9	D *	10	11	
1	2	3	4	5	6	7	8	9	D *	10	11	12	13	14
					M	C/N						M	C	N
4.2	Electrical Testing	1) Burn in check at 50°C for 48 hrs in energized condition	MA	Electrical	100%	100%	Approved drg/ doc	The temperature rise inside the cubicle shall not exceed 10°C during the test.	Inspection Report	√	P	V	V	Burn in test to be performed before offering for BHEL/ Customer Inspection
		2) AVR operation test with input voltage variation of +/- 10%, frequency variation and combined voltage-frequency variation.												
		a) No Load	MA	Electrical	100%	100%	Approved drg/ doc	Approved drg/ doc	Inspection Report	√	P	W	W	
		b) Half Load	MA	Electrical	100%	100%	-do-	-do-	-do-	√	P	W	W	
		c) Full Load	MA	Electrical	100%	100%	-do-	-do-	-do-	√	P	W	W	
		3) Ripple test												
		a) No Load	MA	Electrical	100%	100%	Approved drg/ doc	Approved drg/ doc	Inspection Report	√	P	W	W	
		b) Half Load	MA	Electrical	100%	100%	-do-	-do-	-do-	√	P	W	W	
		c) Full Load	MA	Electrical	100%	100%	-do-	-do-	-do-	√	P	W	W	
		4) Logic simulation/ interlocks/ General Operation Test												
		a) Trickle / boost mode selector switch operation	MA	Electrical	100%	100%	Approved drg/ doc	Functional	Inspection Report	√	P	W	W	
		b) Auto/ manual selector switch operation	MA	Electrical	100%	100%	-do-	Functional	-do-	√	P	W	W	
		c) Soft start feature check	MA	Electrical	100%	100%	-do-	Functional	-do-	√	P	W	W	
		d) Uniform step-less trickle mode voltage adjustment in auto / manual operation	MA	Electrical	100%	100%	-do-	Functional	-do-	√	P	W	W	
		e) Boost charge mode current adjustment from 50% to 100 % continuously	MA	Electrical	100%	100%	-do-	Functional	-do-	√	P	W	W	

BHEL				BIDDER/SUPPLIER		FOR CUSTOMER REVIEW & APPROVAL							
ENGINEERING		QUALITY		Sign & Date		Doc No.		Sign & Date		Name		Seal	
Prepared By	Sign & Date	Name	Prepared By	Sign & Date	Name	Reviewed By	Sign & Date	Name	Checked By	Sign & Date	Name	Seal	
		Kanhaiya Kumar			Kunal Gandhi								
Checked By		Manish Shukla	Checked By		Ritesh K Jaiswal								

KANHAIYA A KUMAR
Digitally signed by KANHAIYA KUMAR
DN: cn=KANHAIYA KUMAR, o=BHEL, ou=PEM,
email=kanhaiya.kumar@bhel.in, c=IN
Date: 2020.08.28 12:47:11 +05'30'

MANISH
Digitally signed by MANISH
DN: cn=MANISH, o=BHEL, ou=PEM,
email=manishshukla@bhel.in, c=IN
Date: 2020.08.28 14:52:36 +05'30'

Digitally signed by Kunal
DN: cn=Kunal, o, ou,
email=kunalgandhi@bhel.in,
c=IN
Date: 2020.08.28 15:09:48
+05'30'

RITESH KUMAR JAISWAL

Digitally signed by RITESH KUMAR JAISWAL
DN: cn=IN, ou=Bharat Heavy Electricals Ltd, ou=BHEL, / PS=PEM, postalCode=201301, st=Uttar Pradesh,
2.5.4.201=16693281523b7f78b46a8e18c5cd0bb18
92753269965349ae8d7191a9e51174,
serialNumber=8cfad9f001b4875a8b03a31b000e9
3f205304622c506e5f9b980e99bc448,
cn=RITESH KUMAR JAISWAL,
Date: 2020.08.28 16:20:08 +05'30'



MANUFACTURER/ BIDDER/ SUPPLIER NAME & ADDRESS		STANDARD QUALITY PLAN			SPEC NO.:PE-TS-XXX-508-E002	DATE:-	
		CUSTOMER				QP NO.:PE-QP-999-508-E003, REV.01	DATE:- 14/06/2020
		PROJECT				P.O NO.:-	DATE:-
		ITEM:- BATTERY CHARGER(SCR BASED)		SYSTEM:- DC SYSTEM		SECTION:-	SHEET 8 OF 9

SL. NO.	COMPONENT & OPERATIONS	CHARACTERISTIC CHECK	CLASS	TYPE OF CHECK	QUANTUM OF CHECK		REFERENCE DOCUMENT	ACCEPTANCE NORMS	FORMAT OF RECORD		AGENCY			REMARKS
					M	C/N			D *	M	C	N		
1	2	3	4	5	6		7	8	9	D *	10			11
					M	C/N					**			
		5) Control circuit & charger status indication test	MA	Electrical	100%	100%	Approved drg/ doc	Functional	Inspection Report	✓	P	W	W	
		6) Load Limiter Operation	MA	Electrical	100%	100%	-do-	Refer Remarks	-do-	✓	P	W	W	Voltage should not drop upto 100% load. Voltage should drop beyond 100% load
		7) Dynamic response test	MA	Electrical	100%	100%	Approved drg/ doc (Also Refer Remarks)	Output Voltgae should stabilise within 2 secs.	-do-	✓	P	W	W	Overshoot / undershoot in output voltage of the charger corresponding to sudden change in load from 100% to 20% and from 20% to 100%.
		8) Input AC current measurement test	MA	Electrical	100%	100%	Approved drg/ doc	Approved drg/ doc	-do-	✓	P	W	W	
		9) Insulation Resistance (I.R) Test	MA	Electrical	100%	100%	IS-13947	IS-13947	-do-	✓	P	W	W	
		10) High Voltage (H.V) Test	MA	Electrical	100%	100%	IS-13947	Charger should be able to withsatnd 2.5kV for 1 min.	-do-	✓	P	W	W	
		11) Efficiency and power factor measurement	MA	Electrical	100%	100%	IS-4540	Approved drg/ doc	-do-	✓	P	W	W	
		12) Degree of protection (DOP) Check for IP 4X (##)	MA	Electrical	100%	100%	IS -2147	Approved drg/ doc	Type Test Report/ Inspection Report	✓	P	V	V	## If DOP test is to be conducted as per project specific Requirement, then Same shall be Witnessed (W') by BHEL/Customer in place of Verification (V') under column 'C' and 'N' of AGENCY(10) Above
		13) Heat Run Test(\$\$) for 8 Hrs.	MA	Electrical	Sample as per Remarks (\$\$)	Sample as per Remarks (\$\$)	Approved drg/ doc	Approved drg/ doc	-do-	✓	P	V	V	\$\$ If Heat run test on defined sample(Project Specific Sample Plan) is to be conducted as per project specific Requirement, then Same shall be Witnessed (W') by BHEL/Customer in place of Verification (V') under column 'C' and 'N' of AGENCY(10) Above

BHEL				BIDDER/SUPPLIER		FOR CUSTOMER REVIEW & APPROVAL			
ENGINEERING		QUALITY		Sign & Date		Doc No.		Seal	
Sign & Date	Name	Sign & Date	Name	Sign & Date	Name	Doc No.	Sign & Date	Name	Seal
Prepared By	Kanhaiya Kumar	Prepared By	Kunal Gandhi	Seal		Reviewed By			
Checked By	Manish Shukla	Checked By	Ritesh K Jaiswal			Checked By			

KANHAIYA KUMAR
Digitally signed by KANHAIYA KUMAR
DN: cn=KANHAIYA KUMAR, o=BHEL, ou=PEM, email=kanhaiya.kumar@bhel.in, c=IN
Date: 2020.08.28 12:47:36 +05'30'

MANISH
Digitally signed by MANISH
DN: cn=MANISH, o=BHEL, ou=PEM, email=manishshukla@bhel.in, c=IN
Date: 2020.08.28 14:53:02 +05'30'

Kunal Gandhi
Digitally signed by Kunal
DN: cn=Kunal, o, ou, email=kunalgandhi@bhel.in, c=IN
Date: 2020.08.28 15:10:34 +05'30'

RITESH KUMAR JAISWAL
Digitally signed by RITESH KUMAR JAISWAL
DN: cn=IN, o=Bharat Heavy Electricals Ltd, ou=BHEL / PS-PEM, postalCode=201301, st=Uttar Pradesh, 2.5.4.20=16692281523b778b46a8e18c5c0db18977532609b5349a8d7191a9e51174, serialNumber=8cfadfd001b4875a8b03a31b000e93f205304f62c650e6d5f9d9980e09bc448, cn=RITESH KUMAR JAISWAL
Date: 2020.08.28 16:20:54 +05'30'

SL. NO.		COMPONENT & OPERATIONS	CHARACTERISTIC CHECK	CLASS	TYPE OF CHECK	QUANTUM OF CHECK	REFERENCE DOCUMENT	ACCEPTANCE NORMS	FORMAT OF RECORD	AGENCY	REMARKS			
1		2	3	4	5	6	7	8	9	D *	10	11		
						M	C/N				**			
											M	C	N	
5		Battery Fuse/MCCB Box	1) Dimensional check	MA	Physical	100%	100%	Approved drg/ doc	Approved drg/ doc	Inspection Report	✓	P	W	W
			2) Fuse Rating	MA	Visual	100%	100%	-do-	-do-	-do-	✓	P	W	W
			3) Insulation Resistance (I.R) Test	MA	Electrical	100%	100%	IS-13947	IS-13947	-do-	✓	P	W	W
6		Discharge Resistor	1) Dimensional check	MA	Physical	100%	100%	Approved drg/ doc	Approved drg/ doc	Inspection Report	✓	P	W	W
			2) Resistance rating	MA	Electrical	100%	100%	-do-	-do-	-do-	✓	P	W	W
			3) Insulation Resistance (I.R) Test	MA	Electrical	100%	100%	IS-13947	IS-13947	-do-	✓	P	W	W
7		Cable Lugs and Glands	1) Visual	MA	Visual	100%	100%	Approved drg/ doc	Approved drg/ doc	Inspection Report	✓	P	W	-
8		Packing	1) Surface Finish & Completeness	MA	Visual	100%	100%	Approved drg/ doc/ As Per Manufacturer Std./ Approved Packing drg/ doc(\$\$)	Approved drg/ doc/ As Per Manufacturer Std./ Approved Packing drg/ doc(\$\$)	-do-	✓	P	W	-

NOTES:-

- Wherever IS standard is mentioned, equivalent IEC/International standard is also acceptable as per applicability of test. In case of any technical requirement not covered by IEC, technical requirement as per IS shall prevail. Latest revision/year of issue of all the IS/IEC standard indicated in QAP shall be referred.
- BHEL Reserves the right for conducting repeat test, if required.
- Photographs of complete Battery Charger Package items after packaging to be sent to BHEL-Purchase Group for review before issuing MDCC.
- In case, any changes in QAP commented by customer at contract stage shall be carried out by bidder without any implication to BHEL/Customer.
- Packing shall be suitable for storage at site in tropical climate conditions.

LEGENDS :

* RECORDS, IDENTIFIED WITH "TICK"(✓) SHALL BE ESSENTIALLY INCLUDED BY SUPPLIER IN QA DOCUMENTATION,

** M: SUPPLIER/ MANUFACTURER/ SUB-SUPPLIER, C: MAIN SUPPLIER/ BHEL/ THIRD PARTY INSPECTION AGENCY, N: CUSTOMER

P: PERFORM, W: WITNESS, V: VERIFICATION, AS APPROPRIATE

MA: MAJOR, MI: MINOR, CR: CRITICAL, D: DOCUMENTATION

BHEL				BIDDER/SUPPLIER		FOR CUSTOMER REVIEW & APPROVAL			
ENGINEERING		QUALITY		Sign & Date		Doc No.	Sign & Date	Name	Seal
Prepared By	Sign & Date	Name	Prepared By	Sign & Date	Name	Reviewed By			
Checked By		Manish Shukla	Checked By		Ritesh K Jaiswal	Checked By			

KANHAIYA A KUMAR
Digitally signed by KANHAIYA KUMAR
DN: cn=KANHAIYA KUMAR, o=BHEL, ou=PEM, email=kanhaiya.kumar@bhel.in, c=IN
Date: 2020.08.28 12:48:01 +05'30'

MANISH

Digitally signed by MANISH
DN: cn=MANISH, o=BHEL, ou=PEM, email=manishshukla@bhel.in, c=IN
Date: 2020.08.28 14:53:27 +05'30'

Kunal Gandhi

Digitally signed by Kunal
DN: cn=Kunal, o, ou, email=kunalgandhi@bhel.in, c=IN
Date: 2020.08.28 15:11:31 +05'30'

RITESH KUMAR JAISWAL

Digitally signed by RITESH KUMAR JAISWAL
DN: cn=IN, o=Bharat Heavy Electricals Ltd, ou=BHEL / P&S/PEM, postalCode=201301, st=Uttar Pradesh, 2.5.4.20=16692a281523b78b46a8e18c5cd0b1b18977532809955349a8e071918a051174, serialNumber=8cfd4d001b48758bb03a31b000e93f20530a62c550e6d5f9d9980e09bc448, cn=RITESH KUMAR JAISWAL
Date: 2020.08.28 16:21:43 +05'30'