





106-1 Rev No. 5	Form No.		PRODUCT STANDARD PULVERISERS HYDERABAD		Product STD no.	BA89222	
				Rev No. 01			
				Page 1 of 13			
<p style="text-align: center;">Technical Specification for detailed Engineering & Supply of Wet ball mill Piping (Water, Slurry & Instrument Air), Valves, Pneumatic distributor box and instruments</p> <p>1. Purpose</p> <p>This specification stipulates the requirements for Design, engineering, manufacture / fabrication, supply, inspection & testing, transportation, handling, lowering, laying & joining, pipe component assembly, hydro-testing, performance guarantee of Slurry piping, Water piping and instrument air piping, design & supply of Valves, Instruments, Strainers, Pipe Fittings, pipe supports, Flanges, Gaskets, Bolting material etc as per the wet ball mill P&ID's.</p> <p>It also covers of Piping layouts, isometrics, stress analysis and supports detailing for wet ball mill piping equipment.</p> <p>Bidder shall refer Document No.BA89223 for qualification requirement.</p> <p>2. General Information</p> <p>Application : Flue Gas Desulphurization plant (wet)</p> <p>Medium handled : Corrosive, abrasive slurry (Limestone)</p> <p>Surrounding : Hot, dusty, humid & corrosive atmosphere</p> <p>Installation : Outdoor (open to sky)</p> <p>Operation : Continuous/Intermittent</p> <p>3 SCOPE OF WORK:</p> <p>Total number of mills -2. (1 working+1stand by). Scope of supply shall include for both mills requirement.</p> <p>Vendor shall thoroughly understand and supply material as per the below annexures</p> <p>Annexure-1 Piping and valves specification which broadly covers the codes and standards to be followed, Design and construction, scope of supply and services, specification of pipes and fittings, services of various categories of valves, specification of gate,/Globe/ check/ball valves and butter fly valves.</p> <p>Annexure-2 P&ID of wet ball mill</p> <p>Annexure 3 Wet ball mill building layout drawing for equipment's location</p>							
REVISION See record notes of revision		PREPARED BY P V S B	APPROVED BY S MAHESH	DATE 15.09.22			

COPYRIGHT AND CONFIDENTIAL
 The information on this document is the property of BHARAT HEAVY ELECTRICALS LIMITED,
 It must not be used directly or indirectly in any way detrimental to the interest of the company.

106-1 Rev No. 5	Form No.		PRODUCT STANDARD PULVERISERS HYDERABAD		Product STD no.	BA89222	
				Rev No. 01			
				Page 2 of 13			
<p style="writing-mode: vertical-rl; transform: rotate(180deg);"> COPYRIGHT AND CONFIDENTIAL The information on this document is the property of BHARAT HEAVY ELECTRICALS LIMITED, It must not be used directly or indirectly in any way detrimental to the interest of the company. </p> <p> Annexure 4 Wet ball mill GA drawing to understand equipment. Annexure-5 Lime stone properties Annexure-6 Mass flow balance. Annexure-7 Control and Instrumentation specification Annexure-8 TECHNICAL SPECIFICATION OF MOTORS Annexure-9 SPECIFICATION FOR CABLES Annexure-10 MANDATORY SPARES Annexure-11 LIST OF DEVIATIONS_EXCEPTIONS Annexure-12 INDICATIVE VENDOR LIST Annexure-13 SPECIFICATION FOR ACTUATORS Annexure-14 MANDATORY SPARES </p> <p> Slurry Pipes sizes up to 400 NB can be provided with either rubber lining / FRP material (silicon carbide coating on slurry exposed surface). Above 400 NB it shall be rubber lining only. </p> <p> For Slurry pipes with Carbon Steel Rubber lined (CSRL): Rubber lining Material is IRR rubber with minimum 4mm thickness . </p> <p> The scope of supply shall include but not limited to the following Vendor shall ensure & quote for both mills requirement. Supply and design includes inside wet ball mill building and up to slurry storage tank. </p> <p> 3.1 Design and Supply 1.Design of all Water, Slurry & Instrument Air Piping Arrangement Documents and supply of all Water, Slurry & Instrument Air Piping as per the attached P&D ANNEXURE -2. Vendor shall ensure the sizes of pipes with respect to mass flow balance given in ANNEXURE-6. 2. Design and supply of all the instruments as per the attached P&ID, ANNEXURE –2. 3.Design and supply of all the valves covered in P&ID, ANNEXURE –2. </p>							
REVISION See record notes of revision		PREPARED BY P V S B	APPROVED BY S MAHESH	DATE 15.09.22			

106-1 Rev No. 5	Form No.		PRODUCT STANDARD PULVERISERS HYDERABAD		Product STD no.	BA89222	
				Rev No. 01			
				Page 3 of 13			
<p style="writing-mode: vertical-rl; transform: rotate(180deg);">COPYRIGHT AND CONFIDENTIAL The information on this document is the property of BHARAT HEAVY ELECTRICALS LIMITED, It must not be used directly or indirectly in any way detrimental to the interest of the company.</p> <p>4.Design & supply of Strainers, Pipe Fittings, pipe supports, Flanges, Gaskets, Bolting material and other equipment's to complete the system .</p> <p>5. Design and submission of Piping layouts, isometrics, 3d model, stress analysis and supports detailing documents..</p> <p>6 Design and submission of All piping (Slurry, water and instrument air) lines and valves sizing report documents</p> <p>7.Design and supply of pneumatic distributor box along with actuator and limit switches. Distribution box details as per P&ID ANNEXURE –2.</p> <p>8.Submission of Bill of material documents.</p> <p>Design shall also Includes basic engineering, detail engineering, preparation and submission of engineering drawings/calculations/datasheets/quality assurance documents/field quality plans, Bill of materials ,storage instructions, commissioning procedures, Erection & assembly Drawings, operation & maintenance manuals, performance guarantee test procedures.</p> <p>**Bidder shall ensure and supply all the items required for completeness of the system.</p> <p>In case, deviations are considered essential by the Bidder (after exhausting all possible Efforts), the same shall be separately listed in the enclosed ANNEXURE-11.</p> <p>No deviation or exception shall be permitted without the written approval of the purchaser.</p> <p>Compliance to this specification shall not relieve the Bidder of the responsibility of furnishing equipment and accessories/auxiliaries of proper design, materials and workmanship to meet the specified start up and operating conditions.</p> <p>4.Inspection & Testing :The scope of the bidder includes all shop tests, type tests, site tests, routine tests etc., fulfilment of complete quality assurance & inspection requirement and related activities for all the equipment & systems covered under the scope of the bidder. Testing shall be carried out in presence of the BHEL / BHEL approved representative based on the BHEL/CUSTOMER approved quality plan, drawings and relevant standards. During inspection, the internal inspection reports shall be submitted to BHEL for info.</p> <p>5.Painting: The bidder scope of work includes supply of paints and painting of all equipment's as per approved painting schedule .</p>							
REVISION See record notes of revision		PREPARED BY P V S B		APPROVED BY S MAHESH		DATE 15.09.22	

106-1 Rev No. 5	Form No.		PRODUCT STANDARD PULVERISERS HYDERABAD		Product STD no.	BA89222																								
				Rev No.	01																									
				Page	4 of 13																									
COPYRIGHT AND CONFIDENTIAL The information on this document is the property of BHARAT HEAVY ELECTRICALS LIMITED, It must not be used directly or indirectly in any way detrimental to the interest of the company.		<p>6. Supervision of Erection & commissioning: Includes supervision of erection & commissioning,</p> <p>7 .Performance Guarantee Test: the guarantee tests shall be carried out as per approved Performance guarantee test procedure, all the special equipment, tools and tackles, instruments, measuring devices required for successful conductance test shall be provided by bidder free of cost.</p> <p>8. Marking</p> <p>The marking on pipe shall include the following:</p> <p>The manufacturer's emblem / logo Pipe size details: Nominal dia, thickness</p> <ul style="list-style-type: none"> • Class of pipe (Pressure rating & Stiffness) • Spool no (if pre-fabricated) • Batch no. or date of manufacture • Colour bands (if applicable) <p>9. Electrical:</p> <p>The scope of supply for electrical system shall include, but not limited to the following. Vendor shall follow Annexure-8 MOTOR SPECIFICATION for design and supply of electrical items.</p> <table border="1" data-bbox="284 1207 1380 1827"> <thead> <tr> <th>SI.No.</th> <th>Package scope matrix</th> <th></th> </tr> </thead> <tbody> <tr> <td>1</td> <td>Cables between bidder's supplied equipment and its raceway</td> <td>Bidder</td> </tr> <tr> <td>2</td> <td>Cable glands and lugs for bidder supply cable</td> <td>Bidder</td> </tr> <tr> <td>3</td> <td>Cable glands for all other cable (all incoming cable)</td> <td>Bidder</td> </tr> <tr> <td>4</td> <td>Skid or equipment mounted Junction Box (JB)</td> <td>Bidder</td> </tr> <tr> <td>5</td> <td>Local Electrical Control Panel (as required)</td> <td>Bidder</td> </tr> <tr> <td>6</td> <td>Electric motors complete with main & auxiliary terminal boxes, space heaters, RTD, BTM, (all temperature detector along with transmitter) and earthing pads.</td> <td>Bidder</td> </tr> <tr> <td>7</td> <td>VFD with accessories (cable sizing, cable race way and cable procurement between VFD and VFD operated motor)</td> <td>Bidder</td> </tr> </tbody> </table>					SI.No.	Package scope matrix		1	Cables between bidder's supplied equipment and its raceway	Bidder	2	Cable glands and lugs for bidder supply cable	Bidder	3	Cable glands for all other cable (all incoming cable)	Bidder	4	Skid or equipment mounted Junction Box (JB)	Bidder	5	Local Electrical Control Panel (as required)	Bidder	6	Electric motors complete with main & auxiliary terminal boxes, space heaters, RTD, BTM, (all temperature detector along with transmitter) and earthing pads.	Bidder	7	VFD with accessories (cable sizing, cable race way and cable procurement between VFD and VFD operated motor)	Bidder
SI.No.	Package scope matrix																													
1	Cables between bidder's supplied equipment and its raceway	Bidder																												
2	Cable glands and lugs for bidder supply cable	Bidder																												
3	Cable glands for all other cable (all incoming cable)	Bidder																												
4	Skid or equipment mounted Junction Box (JB)	Bidder																												
5	Local Electrical Control Panel (as required)	Bidder																												
6	Electric motors complete with main & auxiliary terminal boxes, space heaters, RTD, BTM, (all temperature detector along with transmitter) and earthing pads.	Bidder																												
7	VFD with accessories (cable sizing, cable race way and cable procurement between VFD and VFD operated motor)	Bidder																												
REVISION See record notes of revision		PREPARED BY P V S B	APPROVED BY S MAHESH	DATE 15.09.22																										

106-1 Rev No. 5	Form No.		PRODUCT STANDARD PULVERISERS HYDERABAD		Product STD no.	BA89222												
					Rev No. 01													
					Page 5 of 13													
<p style="writing-mode: vertical-rl; transform: rotate(180deg);"> COPYRIGHT AND CONFIDENTIAL The information on this document is the property of BHARAT HEAVY ELECTRICALS LIMITED, It must not be used directly or indirectly in any way detrimental to the interest of the company. </p> <table border="1" data-bbox="282 302 1382 779"> <tr> <td style="text-align: center;">8</td> <td>Motorised valves with actuators & integral starter of actuator.</td> <td>Bidder</td> </tr> <tr> <td style="text-align: center;">9</td> <td>Grounding provision for all equipment for connection to the Purchaser's earthing conductor/grid. Skid mounted equipment shall be earthed through skid ground pad. All the equipment on by Supplier's skid shall be earthed up to the skid ground pad.</td> <td>Bidder</td> </tr> <tr> <td style="text-align: center;">10</td> <td>Special Cable (if any) including cabling, termination & accessories, Cable trays/conduits with supporting system.</td> <td>Bidder</td> </tr> <tr> <td style="text-align: center;">11</td> <td>Any other required electrical devices for safe and trouble free operation of the plant</td> <td>Bidder</td> </tr> </table> <p>10 Control & Instrument</p> <p>Vendor shall follow Annexure-7 CONTROL AND INSTRUMENTATION SPECIFICATION For design and supply of electrical items.</p> <p>.10.1 The instruments and controls to be furnished and erected under this specification are as required for safe and satisfactory operation of the Bidder supplied system, as outlined under mechanical section and as specified elsewhere in the specification. For the equipment and materials procured by the bidder from his sub-vendors, the bidder shall study the specification, safety requirements, interface drawings for such equipment and material in detail and shall coordinate his work with his sub vendors and FGD DDCMIS</p> <p>(By purchaser) system and supply instrumentation and control to suit the actual equipment.</p> <p>10.2 Complete Control & Instrumentation (C&I) systems with all accessories, as per final approved P&ID & Flow Diagram, whether or not specifically included in this specification, shall be supplied by bidder, within the quoted price.</p> <p>10.3 All the necessary field instrumentation (i.e. Transmitters, process actuated switches, sensors, final control elements, solenoid / motor operated valves, etc. as per finally approved P&ID/Flow Scheme. shall be supplied by Bidder.</p> <p>.10.4 All transmitters, gauges etc. shall be suitably grouped together and Mounted inside: Local Instruments Enclosures (LIEs) in case of open areas In Local Instrument Racks (LIRs) in case of covered areas.</p>							8	Motorised valves with actuators & integral starter of actuator.	Bidder	9	Grounding provision for all equipment for connection to the Purchaser's earthing conductor/grid. Skid mounted equipment shall be earthed through skid ground pad. All the equipment on by Supplier's skid shall be earthed up to the skid ground pad.	Bidder	10	Special Cable (if any) including cabling, termination & accessories, Cable trays/conduits with supporting system.	Bidder	11	Any other required electrical devices for safe and trouble free operation of the plant	Bidder
							8	Motorised valves with actuators & integral starter of actuator.	Bidder									
9	Grounding provision for all equipment for connection to the Purchaser's earthing conductor/grid. Skid mounted equipment shall be earthed through skid ground pad. All the equipment on by Supplier's skid shall be earthed up to the skid ground pad.	Bidder																
10	Special Cable (if any) including cabling, termination & accessories, Cable trays/conduits with supporting system.	Bidder																
11	Any other required electrical devices for safe and trouble free operation of the plant	Bidder																
REVISION See record notes of revision	PREPARED BY P V S B	APPROVED BY S MAHESH	DATE 15.09.22															

106-1 Rev No. 5	Form No.		PRODUCT STANDARD PULVERISERS HYDERABAD		Product STD no.	BA89222
				Rev No.	01	
				Page	6 of 13	
COPYRIGHT AND CONFIDENTIAL The information on this document is the property of BHARAT HEAVY ELECTRICALS LIMITED, It must not be used directly or indirectly in any way detrimental to the interest of the company.		<p>Instrument rack / enclosure shall be free standing type with CRCA steel with Epoxy coating (RAL 7035) – Bidder shall follow the approved painting schedule will be given during detail engineering.</p> <p>Each enclosure shall be robust, rigid and having a viewing glass to take readings. Canopy shall be provided for all the racks.</p> <p>All transmitter / gauges drains shall be connected to drain header bottom of the Rack (1" Size drain header). Same is not applicable for diaphragm type instrument.</p> <p>Stainless Steel Tag plate to be firmly fixed with screws. Field mounting shall be done with SS anchor fasteners to be provided by supplier.</p> <p>Each device shall be so mounted and piped with adequate spacing allowed for wiring so that instrument removal, replacement, and servicing may be accomplished without interruption of service to adjacent devices or unduly disturbing piping and tubing.</p> <p>Instruments shall be located in instrument enclosure or rack containing maximum up to six instruments.</p> <p>Dimension shall be provided by supplier. In case grouping is not possible and installed individually, canopy shall be provided. The grouping and design of racks/ canopy shall be approved by Employer during detail engineering. Bidder shall supply LIE/LIR as per finally approved drawings within the quoted price.</p> <p>10.5 For skid mounted instruments and instruments integral to equipments, process connection and piping can be in line with bidder's standard and proven practice.</p> <p>10.6. Detailed operation and control philosophy for all the equipment's shall be furnished by bidder and the same shall be subject to purchaser / owner's approval during detailed engineering.</p> <p>10.. All instruments/JB/racks shall be tagged as per Purchaser's tagging philosophy.</p> <p>10.8 Scope of C&I Cable and Cable engineering: Bidder shall include following instrumentation and control cables in bidder's scope along with all accessories like Cable glands, lugs, ferrules, etc. Further, complete package cable engineering for Bidder's supplied cables shall be in Bidder's scope.</p> <ul style="list-style-type: none"> • From field instruments/ valves/ devices to JB's – Bidder's scope • From JB's/field instruments/valves/ devices to Bidder's supplied Local panels : Bidder's scope • Between BIDDER's supplied items – Bidder's scope • From JB's / local panels to DDCMIS cabinet – Purchaser's Scope <p>10.9 All required mounting & erection hardware like impulse pipes/ tubes, SS/ PVC insulated copper tubes, root/ drain valves and instrument fittings, snubbers, pulsation dampeners, gauge protector, counter flanges, cable glands, and instrument rack/</p>				
REVISION See record notes of revision		PREPARED BY P V S B	APPROVED BY S MAHESH	DATE 15.09.22		

106-1 Rev No. 5	Form No.		<p style="text-align: center;">PRODUCT STANDARD</p> <p style="text-align: center;">PULVERISERS</p> <p style="text-align: center;">HYDERABAD</p>		Product STD no.	BA89222
					Rev No.	01
					Page	7 of 13
<p style="writing-mode: vertical-rl; transform: rotate(180deg);">COPYRIGHT AND CONFIDENTIAL</p> <p style="writing-mode: vertical-rl; transform: rotate(180deg);">The information on this document is the property of BHARAT HEAVY ELECTRICALS LIMITED, It must not be used directly or indirectly in any way detrimental to the interest of the company.</p>		<p>stanchion/ enclosure for installing Bidder's supplied instruments on as required basis.</p> <p>10.10 The equipment shall employ latest state of the art technology to guard against obsolescence. In any case, Bidder shall be required to ensure supply of spare parts for lifetime of the plant. In case, the Bidder feels that certain equipment/component is likely to become obsolete, the Bidder shall clearly bring out the same in his Bid and indicate steps proposed to deal with such obsolescence.</p> <p>10.11 For DDCMIS preparation of logic/loops in case of operation from DDCMIS, I/O list, Drive list, Instrument List, mimics/ displays etc. shall be provided by Bidder for implementation in DDCMIS.</p> <p>10.12 Bidder shall provide IO quantity (DI, DO, AI, AO) for bidder supplied equipment in the offer.</p> <p>10.13 Bidder shall support as required for smooth engineering including DDCMIS up to commissioning & handover of bidder supplied equipment along with Control system (DDCMIS) to Purchaser.</p> <p>10.14 All actuators shall be certified for SIL 2 or better.</p> <p style="text-align: center;">* Communication protocol to be followed shall be Conventional HART type.</p> <p>11. Packing & Transportation Requirements</p> <p>Ends of pipe, fittings and pipe openings shall be sealed to prevent entrance of dirt, water, or other foreign matter. All pipe and pipe fittings shall be suitably protected, coated, covered or boxed to prevent damage or deterioration during transit, handling and storage at site, till the time of erection.</p> <p>Each packing shall have necessary handling marks. Boxes, bags, or bundles of small parts shall be tagged or labelled with weatherproof tags. Each packing shall contain a packing slip indicating the details of item like item description, quantity, weight etc. Detailed packing list shall be submitted for BHEL approval for giving dispatch clearance by BHEL.</p> <p>Details of handling & Storage instruction shall also be provided in each packing. Vendor shall submit a write up for safe handling and stacking of pipes during transportation and at site.</p> <p>All items shall be properly packed with adequate cushioning material to prevent rough handling and transport. Special care shall be given to prevent damage to the piping components.</p> <p>In case of transport by ship, packing shall be sea worthy so as to ensure safe delivery</p>				
		REVISION See record notes of revision	PREPARED BY P V S B	APPROVED BY S MAHESH	DATE 15.09.22	

COPYRIGHT AND CONFIDENTIAL
 The information on this document is the property of BHARAT HEAVY ELECTRICALS LIMITED,
 It must not be used directly or indirectly in any way detrimental to the interest of the company.

till site.

The material being delivered at site shall be jointly inspected by BHEL and vendor. Defective or damaged pipe shall be rejected by BHEL and vendor is liable to replace the same with new ones without any commercial implications to BHEL. In case of minor damage, the BHEL may allow repair of the pipe by the Vendor to the satisfaction of the BHEL.

12. PAINTING REQUIREMENTS

Painting shall be followed as per approved painting scheme. However, for components where no specific requirement is stipulated, the painting conforming to the requirements stipulated below shall be as per OEM practice

13. Documents Submission:

13.1 Documents along with offer

Bidder shall submit the following drawings/data and technical information along with their Techno-commercial offer

Item	Description
1.	General arrangement drawing of belt weight feeder
2.	Quality assurance plan(QAP)
3.	Published equipment brochures and documents
4.	Experience/installation list of similar projects
5.	Other vendor supplied supporting documents
6.	Warranty & performance guarantee schedule
7.	Sub vendor list
8.	Guaranteed auxiliary power consumption
9.	Complete electrical load list .

13.2 Documents after award of contract. Bidder shall submit the following drawings/data and technical information along with after award of contract. For

REVISION See record notes of revision	PREPARED BY P V S B	APPROVED BY S MAHESH	DATE 15.09.22
--	------------------------	-------------------------	------------------

COPYRIGHT AND CONFIDENTIAL
 The information on this document is the property of BHARAT HEAVY ELECTRICALS LIMITED,
 It must not be used directly or indirectly in any way detrimental to the interest of the company.

approval or Information:

Item	Description
1.	All Piping Arrangement Drawings (Water, Slurry & Instrument Air) - In Mill Building
2.	All piping (Slurry, water and instrument air) lines and valves sizing report
3.	Data sheet of Pipe & fittings for Air & water system
4.	Data sheet of Pipe Fittings for Slurry application
5.	Data sheet of Pipe for Slurry application
6.	Data sheet of valves for Air & water
7.	Data sheet of valves for Slurry application
8.	Data sheets & catalogues for Instrumentation Cables & Special Cables of Ball Mill
9.	Data Sheets & Catalogues for Process Water Control Valve of Ball Mill
10.	Datasheet & Catalogue of Density Meter (Mass Flow Meter)
11.	Datasheet and Catalogue for Temperature Transmitters (LIR Mounted)& Pressure transimeters
12.	Datasheet of Non-Intrusive Motorised Actuators
13.	JB GA & IGA drawing
14.	GA & IGA dwg of LIR mounted Temp Transmitter
15.	Total Instrumentation Data Sheet
16.	Piping layouts documents, isometrics, stress analysis and supports detailing for wet ball mill piping equipment
17.	Isometric drawings
18.	supports detailing for wet ball mill piping equipment.
19.	Quality assurance plan(QAP)

REVISION See record notes of revision	PREPARED BY P V S B	APPROVED BY S MAHESH	DATE 15.09.22
---	-------------------------------	--------------------------------	-------------------------

106-1 Rev No. 5	Form No.		PRODUCT STANDARD PULVERISERS HYDERABAD		Product STD no.	BA89222																									
				Rev No.	01																										
				Page	10 of 13																										
<p style="writing-mode: vertical-rl; transform: rotate(180deg);">COPYRIGHT AND CONFIDENTIAL</p> <p style="writing-mode: vertical-rl; transform: rotate(180deg);">The information on this document is the property of BHARAT HEAVY ELECTRICALS LIMITED, It must not be used directly or indirectly in any way detrimental to the interest of the company.</p>																															
<table border="1"> <tr><td>20.</td><td>Utility Consumption & Lubricating Oil List</td></tr> <tr><td>21.</td><td>Equipment sizing & Motor sizing calculations</td></tr> <tr><td>22.</td><td>Sub vendor items documents & quality plans</td></tr> <tr><td>23.</td><td>Sub vendor list</td></tr> <tr><td>24.</td><td>GA Drawings with dimensional details of all offered panels</td></tr> <tr><td>25.</td><td>Complete electrical load list .</td></tr> <tr><td>26.</td><td>loading details(static and dynamic loads) Drawing, Anchor Bolts, mounting plates static & dynamic details</td></tr> <tr><td>27.</td><td>Cross sectional drawings</td></tr> <tr><td>28.</td><td>Erection and commissioning manual</td></tr> <tr><td>29.</td><td>Performance test procedures</td></tr> <tr><td>30.</td><td>Shop inspection and test procedures</td></tr> <tr><td>31.</td><td>Operation and maintenance manual in a comprehensive manner prepared for use by operating and maintenance personnel.(3 sets)</td></tr> </table>								20.	Utility Consumption & Lubricating Oil List	21.	Equipment sizing & Motor sizing calculations	22.	Sub vendor items documents & quality plans	23.	Sub vendor list	24.	GA Drawings with dimensional details of all offered panels	25.	Complete electrical load list .	26.	loading details(static and dynamic loads) Drawing, Anchor Bolts, mounting plates static & dynamic details	27.	Cross sectional drawings	28.	Erection and commissioning manual	29.	Performance test procedures	30.	Shop inspection and test procedures	31.	Operation and maintenance manual in a comprehensive manner prepared for use by operating and maintenance personnel.(3 sets)
20.	Utility Consumption & Lubricating Oil List																														
21.	Equipment sizing & Motor sizing calculations																														
22.	Sub vendor items documents & quality plans																														
23.	Sub vendor list																														
24.	GA Drawings with dimensional details of all offered panels																														
25.	Complete electrical load list .																														
26.	loading details(static and dynamic loads) Drawing, Anchor Bolts, mounting plates static & dynamic details																														
27.	Cross sectional drawings																														
28.	Erection and commissioning manual																														
29.	Performance test procedures																														
30.	Shop inspection and test procedures																														
31.	Operation and maintenance manual in a comprehensive manner prepared for use by operating and maintenance personnel.(3 sets)																														
<ul style="list-style-type: none"> • MDL shall be finalized with the successful Bidder after award of contract. • Other drawings as may be required will be determined at a later date. • Bidder shall submit instruction manual for all the equipment's covered under the scope of bidder as per agreed engineering schedule. The instruction manuals shall contain full details required for erection, commissioning, operation and maintenance of each equipment. The manual shall be specifically complied for this project. The erection portion of manual shall contain erection strategy, sequence of erection, erection instructions, critical checks (along with permissible deviations/tolerance), Bill Of Materials, procedure for erection, general safety procedures to be followed. Procedure for initial checking after erection, procedure for testing (along with acceptance norms) check list for commissioning/pre-commissioning activities, List of tools and tackles. 																															
REVISION See record notes of revision		PREPARED BY P V S B		APPROVED BY S MAHESH		DATE 15.09.22																									

106-1 Rev No. 5	Form No.		PRODUCT STANDARD PULVERISERS HYDERABAD		Product STD no.	BA89222
				Rev No.	01	
				Page	11	of 13
COPYRIGHT AND CONFIDENTIAL The information on this document is the property of BHARAT HEAVY ELECTRICALS LIMITED, It must not be used directly or indirectly in any way detrimental to the interest of the company.		<p style="text-align: center;">14. SUPERVISION OF ERECTION, TESTING AND COMMISSIONING</p> <ul style="list-style-type: none"> • The erection of piping ,valves and instruments will be done by owner (BHEL) as per Erection Manual and check List provided by bidder. The bidder has to supervise for erection, pre-commissioning & post- commissioning check-up, start-up, trial runs of all the items covered under the scope of supply. • There will be two visits . The bidder will be informed well in advance for the visit. Bidder shall consider 15 working days. • In case erection and commissioning activities get delayed due to any account, resulting into overstay of vendor supervisory engineer beyond schedule time, then BHEL shall pay for additional man-day stay of vendor supervisory engineers. Vendor to quote Per day cost for deputation along with this offer. • TA/DA, boarding and lodging shall be borne by the bidder and shall be inclusive in supervision charges portion. • Charges for supervision of Erection & commissioning shall be quoted by the bidder. <p>**Confirmation shall be taken from BHEL during detail engineering for Mating flanges and inter connection details accordingly material shall be supplied.</p> <p>**All the utility pipes (water pipes, instrument air, etc.,) are provided at single point near to limestone ball mill building. Bidder has to further take the piping from the point terminated by BHEL</p> <p>14.Guarantee/ Warranty Requirement:</p> <ul style="list-style-type: none"> • 18 months from the date of commissioning or 24 months from the date of supply whichever is early <p>15.Mandatory spares: Mandatory spares shall quote as per attached annexure-14 along with offer.</p> <p>Price comparison for evaluating the lowest bid will be considered all main supply, supervision of E&C charges and mandatory spares price.</p>				
REVISION See record notes of revision		PREPARED BY P V S B	APPROVED BY S MAHESH	DATE 15.09.22		



PRODUCT STANDARD

PULVERISERS HYDERABAD

Product
STD no.

BA89222

Rev No. 01

Page 12 of 13

16 Excusions

- 1 .WET BALL MILLIS
- 2.MILL CIRCUIT TANKS
- 3.MILL CIRCUIT PUMPS
- 4.HYDROCYCLONES
- 5.WEIGH FEEDERS
- 6.STORAGE SLURRY TANKS
- 7.HOISTS
- 8.MILL INLET& OUT CHUTES
- 9.FEEDER INLET OUTLET GATES ALONG WITH CONNECTION CHUTES
- 10 PNEUMATIC DIVERTER &GATE ALONG WITH CHUTES

ANNEXURES LIST:

Annexure Sl. No.	Description
1.	SPECIFICATION FOR PIPES ,PIPE FITTINGS AND VALVES
2.	P& ID FOR WET BALL MILL
3.	WET BALL MILL BUILDING DRAWING
4.	MILL GA DRAWING
5.	LIME STONE AND WATER PROPERTIES
6.	MASS FLOW BLANCE WBM
7.	CONTROL AND INSTRUMENTATION SPECIFICATION
8.	TECHNICAL SPECIFICATION OF MOTORS
9.	SPECIFICATION FOR CABLES
10.	GENERAL INFORMATION
11.	LIST OF DEVIATIONS EXCEPTIONS
12.	INDICATIVE VENDOR LIST
13.	SPECIFICATION FOR ELECTRIC ACTUATORS
14	MANDATORY SPARES

COPYRIGHT AND CONFIDENTIAL
 The information on this document is the property of BHARAT HEAVY ELECTRICALS LIMITED,
 It must not be used directly or indirectly in any way detrimental to the interest of the company.

REVISION
See record notes of revision

PREPARED BY
P V S B

APPROVED BY
S MAHESH

DATE
15.09.22

106-1
Rev No. 5

Form No.



PRODUCT STANDARD
PULVERISERS
HYDERABAD

Product
STD no.

BA89222

Rev No. 01

Page 13 of 13

VARIANTS – TABLE

VARIANT NO.	DESCRIPTION	MATEIRAL CODE
00	WBM DESN&SUP PIPING, VALV&INST KOTHAGUD	BA9789222009
01	MILL CIRCUIT SLURRY VALVES	BA9789222017
02	MILL CIRCUIT SLURRY LINE BENDS	BA9789222025
03	TRANSMITTERS/GAUGES/SWITCHES ,ETC.ALONG	BA9789222033
04	TEMPERATURE (RTD/THERMO- COUPLE)WITH THE	BA9789222041

RECORD OF REVISIONS

REV. NO	DATE	REVISION DETAILS	REVISED	APPROVED

COPYRIGHT AND CONFIDENTIAL
The information on this document is the property of BHARAT HEAVY ELECTRICALS LIMITED,
It must not be used directly or indirectly in any way detrimental to the interest of the company.

REVISION
See record notes of revision

PREPARED BY
P V S B

APPROVED BY
S MAHESH

DATE
15.09.22

TECHNICAL SPECIFICATION OF PIPING

EQUIPMENT SIZING CRITERIA

All the piping systems and equipment supplied under this package shall be designed to operate without replacement and with normal maintenance for a plant service life of 30 years, and shall withstand the operating parameter fluctuations and cycling which can be normally expected during this period.

For all Low Pressure piping systems covered under this specification, sizing and system design shall be to the requirements of relevant codes and standard indicated. In addition to this, requirements of any statutory code as applicable shall also be taken into consideration.

Inside diameters of piping shall be calculated for the flow requirements of various systems.

The velocities for calculating the inside diameters shall be limited to the following:

a) Water Application

Water Velocity in m/sec

Pipe Size	Below 50 mm	50-150 mm	200 mm & above
(a) Pump suction	-----	1.2-1.5	1.2-1.8
(b) Pump discharge and recirculation	1.2-1.8	1.8-2.4	2.1-2.5
(c) Header	-----	1.5-2.4	2.1-2.4

Pipe line under gravity flow shall be restricted to a flow velocity of 1 m/sec generally. Channels under gravity flow shall be sized for a maximum flow velocity of 0.6 m/sec.

WILLIAM & HAZEN formula shall be used for calculating the friction loss in piping systems with the following "C" value:

(i) Carbon steel pipe	100
(ii) Ductile Iron.	140
(iii) Rubber lined steel pipe	120
(iv) Stainless steel pipe	100

For calculating the required pump head for pump selection, at least 10% margin shall be taken over the pipe friction losses and static head shall be calculated from the minimum water level of the tank/ sump/ reservoir from which the pumps draw water.

b) Compressed Air Application

Compressed air 15.0 m/sec.(under Average Pressure & Temp. conditions)

The pipes shall be sized for the worst (i.e. maximum flow, temp. and pressure values) operating conditions.

Based on the inside dia. so established, thickness calculation shall be made as per ANSI B 31.1 OD and thickness of pipes shall than be selected as per ANSI B 36.10/IS-1239 Heavy grade/IS-3589/ASTM-A-53/API-5L/ANSI B 36.19 as the case may be.

Corrosion allowance of 1.6 mm will be added to the calculated thickness being considered (except stainless steel piping).

Bend thinning allowance/manufacturing allowance etc. shall be as per the requirement of the design code provision.

High points in piping system shall be provided with vents along with valves as per the system requirement. Low points shall be provided with drains along with drain valves as per the system requirement. Drain lines shall be adequately sized so as to clear condensate in the lines. Material for drain and vent lines shall be compatible with that of the parent pipe material.

Material of construction for pipes carrying various fluids shall be as specified elsewhere.

Compressed air pipe work shall be adequately drained to prevent internal moisture accumulation and moisture traps shall be provided at strategic locations in the piping systems.

Depending upon the size and system pressure, joints in compressed air pipe work shall be screwed or flanged. The flange shall be welded with the parent pipe at shop and shall be hot dip galvanized before dispatch to site. Alternatively, the flanges on GI pipes may be screwed on flanges also.

Threaded joints shall be provided with Teflon sealant tapes.

Following types of valves shall be used for the system/service indicated.

SYSTEM TYPES OF VALVES

	Butterfly	Gate	Globe	Check	Ball	Plug
Water	x	x	x	x	x	
Air		x	x	x	x	
Drains & vents			x	x	x	
Fuel oil (if any)		x	x	x	x	x

Recirculation pipes along with valves, breakdown orifices etc. shall be provided for important pumping systems as indicated in respective process and instrumentation diagrams (P&IDs). The recirculation pipe shall be sized for minimum 30% design flow of single pump operation or the recommended flow of the pump manufacturer whichever is higher.

TECHNICAL SPECIFICATION

GENERAL

Specific technical requirements of low-pressure piping, fittings, supports, valves, specialties and tanks etc. have been covered under this Sub-section. It includes details pertaining to design and material of construction for piping, fittings, valves, equipment, etc. cleaning/surface preparation application of primer and painting on over ground piping. It also includes detailed technical requirement of laying underground/buried piping including water proofing/anti corrosive protection. It also covers design,

engineering, manufacturing, fabrication, technical details of piping, valves, specialties, piping hangers / supports, tanks etc.

PIPES AND FITTINGS

All low pressure piping systems shall be capable of withstanding the maximum pressure in the corresponding lines at the relevant temperatures. However, the minimum thickness as specified in the following clauses and or respective codes for pipes and fittings shall be adhered to. The bidder shall furnish the pipe sizing/ thickness calculation as per the criteria mentioned above under LP piping equipment sizing criteria of this Technical Specification.

Piping and fittings coming under the purview of IBR shall be designed satisfying the requirements of IBR as a minimum.

Supporting arrangement of piping systems shall be properly designed for systems where hydraulic shocks and pressure surges may arise in the system during operation. Bidder should provide necessary protective arrangement like anchor blocks/anchor bolt etc. for the safeguard of the piping systems under above mentioned conditions. The requirement will be, however, worked out by the contractor and he will submit the detailed drawings for thrust/anchor block to the Employer. External, and internal, attachments to piping shall be designed so as not to cause flattening of pipes and excessive localized bending stresses.

Bends, loops, off sets, expansion or flexible joints shall be used as required in order to prevent overstressing the piping system and to provide adequate flexibility. Flexibility analysis (using software packages such as Caesar-II etc.) shall be carried out for sufficiently long piping (straight run more than 300M).

Wherever Bidder's piping coming under this specification, terminates at an equipment's or terminal point not included in this specification, the reaction and the thermal movement imposed by bidder's piping on equipment terminal point shall be within limits to be approved by the Employer

The hot lines shall be supported with flexible connections to permit axial and lateral movements. Flexibility analysis shall be carried out for pipelines which have considerable straight run as indicated above and necessary loops/ expansion joint etc. shall be provided as may be necessary depending on layout.

Piping and fittings shall be manufactured by an approved manufacturer of repute. They should be truly cylindrical of clear internal diameter, of uniform thickness, smooth and strong, free from dents, cracks and holes and other defects.

For rubber lined ERW pipes, beads shall be removed for pipe size 80 NB and above.

Inspection holes shall be provided at suitable locations for pipes 800 NB and above as required for periodic observations and inspection purposes.

At all intersection joints, it is Contractor's responsibility to design and provide suitable reinforcements as per the applicable codes and standards.

For large size pipes/ducts, at high point and bends/change of direction of flow, air release valves shall be provided as dictated by the system requirement and operation philosophy & tripping conditions of pumping system. Sizing criteria for air release valves shall be generally on the basis of valve size to pipe diameter ratio of 1:8. Requirement shall be decided as per relevant code.

Transient analysis /surge analysis where ever specified and required shall be conducted in order to determine the location , number and size of the Air-Release valve on certain long distance/high volume piping systems, if applicable within the scope of work of the package.

Material

Alternate materials offered by Bidder against those specified. shall either be equal to or superior to those specified, The responsibility for establishing equality or superiority of the alternate materials offered rests entirely with the Bidder and any standard code required for establishing the same shall be in English language.

No extra credit would be given to offers containing materials superior to those specified. Likewise no extra credit would be given to offers containing pipe thickness more than specified.

All materials shall be new and procured directly from the manufacturers. Materials procured from traders or stockists are not acceptable.

All materials shall be certified by proper material test certificates. All material test certificates shall carry proper heat number or other acceptable references to enable identification of the certificate that certifies the material.

Material of construction for pipes carrying various fluids shall be as follows:

SI N	Type of Fluid	Material
1.	i) Ordinary Water (Raw Water, Clarified Water, etc.) ii) Equipment cooling water including Both primary & secondary circuit (DMCW pH-corrected & ACW drain water)	IS-2062 Gr.-E-250B/ASTM A-36/ASTM A-53 type 'E'Gr.B/IS-3589 Gr. 410 /IS-1239 Heavy.
2.	i) Demineralised water, ii)Alkaline solution (ECW system chemical dosing)	Stainless Steel to ASTM A312, Gr. 304 welded for sizes 65 mm NB and above. Stainless steel to ASTM A312, Gr. 304 sch.40s seamless for sizes 50mm and below
3.	i) Drinking (potable) water ii)Compressed air (Instrument & service air)	ASTM A-53 type E Gr. B galvanized/ IS 1239 Gr heavy galvanized/IS 3589 Gr 410 galvanized. Galvanized shall be to IS- 4736 or equivalent.

Note: For Vallur TPP, piping (pipe, fittings etc) material details, conveying sea water or permeate water shall be as per Sea water PT cum Desalination plant and ECW system chapter.

In water lines, pipes upto 150mm Nb shall conform to ANSI B36.10/ASTM-A-53, Type-E Gr.B /IS:1239 Gr. Heavy and minimum selected thickness shall not be less than IS:1239 Grade Heavy except for demineralized water, drinking water .

Pipes of above 150mm Nb shall be to AWWA-C200/ANSI B 36.10/ASTM A-53/IS 3589 Gr.410. Pipe to be fabricated by the bidder shall be rolled and butt welded from plates conforming to ASTM A-53 type 'E' Gr. B/IS 2062 Gr.E-250B/ASTM-A-36. However, larger pipes, i.e. 1000mm Nb and above shall be made from plates conforming to ASTM A 36/IS 2062 Gr.E-250B and shall meet the requirements of AWWA-M-11 (for deflection & buckling criteria considering water filled pipe as well as vacuum condition that may prevail during transient/surge conditions, truck-load, rail-load and weight density for compacted soil or any other load as the case may be).

In demineralised water service, the pipes upto 50 Nb shall be of stainless steel ASTM A 312, Gr. 304 sch. 40 Seamless. The size for these pipes shall be to ANSI B 36.19. These shall be socket welded. The material for pipe from 65mm NB upto and including 400 NB shall be to ASTM A 312, Gr. 304 (welded). In no case the thickness of fittings shall be less than parent pipe thickness.

Bidder/Contractor shall note that pipes offered as per a particular code shall conform to that code in all respects i.e. Dimension, tolerances, manufacturing methods, material, heat treatment, testing requirements, etc. unless otherwise mentioned elsewhere in the specification.

Instrument air, Plant (service) air lines and Drinking water lines shall be to ASTM A 53 type E grade B/ANSI B 36. 10/IS 3589, Gr. 410 / IS: 1239 Heavy (in case thickness calculated is more than gr. Heavy, ANSI B 36.10 Schedule numbers shall be followed) and galvanized to IS 4736 or any equivalent internationally reputed standard. The material of the pipes shall be to ASTM A 53 type 'E' Gr. B / IS:

3589, Gr. 410 / IS: 1239 Gr. Heavy. The fittings shall be of either same as parent material or malleable iron to IS-1879 (galvanized).

Spiral welded pipes as per API-5L/IS-3589 are also acceptable for pipe of size above 150 NB. However minimum thickness of the pipes shall be as elaborated in above clauses.

Condensate lines shall be to ASTM A 106 Gr. B and dimension to ANSI B 36.10 schedule "standard" as minimum to be maintained.

If carbon steel plates of thickness more than 12 mm are used for manufacture of pipes, fittings and other appurtenances, then the same shall be control-cooled or normalized as the case may be following the guidelines of the governing code.

Field routed pipes:

Pipe lines of NB 50 size and below are regarded as field run piping. It is Bidder's responsibility to plan suitable layouts for these system insitu. Bidder shall prepare drawings indicating the layout of field run pipe work. These drawings shall be approved by Project Manager to the installation of the field run pipe work. Based on these approved layouts the Bidder shall prepare the BOQ of field run-pipes and submit to Employer for approval.

Slope/Drains and Vents

Suitable slope shall be provided for all pipelines towards drain points. It is Bidder responsibility to identify the requirements of drains and vents, and supply the necessary pipe work, valves, fittings, hangers and supports etc. As per the system requirement low points in the pipelines shall be provided with suitable draining arrangement and high points shall be provided with vent connections where air or gas pockets may occur. Vent for use during hydrostatic test shall be plugged after the completion of the test. Vent shall not be less than 15mm size. Drains shall be provided at low points and at pockets in piping such that complete drainage of all systems is possible. Drain shall not be less than 15mm for line size up to 150mm, not less than 20mm up to 300mm and not less than 25mm for 350mm to 600mm pipes and not less than 50mm for 600mm and above pipes.

Air piping shall be sloped so that any part of the system can be drained through the shut-off drain valve or drain plugs.

Pipe Joints

In general all water lines 65mm NB and above, are to be joined generally by butt welding except the locations where valves/fittings are to be installed with flanged connections and 50mm and below by socket welding unless mentioned otherwise specifically. All air lines shall be of screwed connection and rubber lined pipes of flanged connections.

Screwed Joints

- (a) Threading of pipes shall be carried out after bending, heat treatment etc. If not possible, threading may be done prior to these operations but proper care should be taken to protect them from damage. Threads shall be to ANSI B 2.1 (taper) NPT/ ANSI B1.20.1 (taper) NPT / IS: 554 unless specified otherwise.
- (b) Galvanized pipe shall generally be joined by screwing into sockets. The exposed threaded portion on the outside of the pipes shall be given a zinc silicate coating. Galvanized pipes shall not be field joined by welding for protection of Galvanising Zinc layer. Screwed ends of GI pipes shall be thoroughly cleaned and painted with a mixture of red and white lead before jointing. For galvanized pipe sizes above 150 mm NB, screw & socket jointing as per ASTM-A-865 shall be employed for both pipe-to-pipe and pipe-to-fitting jointing. For pipe to fitting connection since no direct threading can be done on the fittings (supplied as per ASTM-A-234 Gr. WPB and ANSI B-16.9) necessary straight pipe lengths acting as match pieces shall be welded to the fitting at both ends and subsequently the free ends of the straight lengths shall be threaded as per ASTM A-865 for jointing with main pipe. Once welding of fittings with match pieces and threading of free ends of match pieces are over, the entire fabricated piece shall be galvanized, or in case match pipes and fittings are already galvanized before the above mentioned fabrication then suitable application of Zinc- Silicate paste adequately at the welded surface (both in side & outside) after welding with zinc rich electrode, along with the nascent threaded metal portions at both free ends given the same application of Zinc Silicate paste. Alternatively flanged jointing may be employed for pipe sizes 100 NB and above. However, the bidder shall ensure the galvanized pipe joints do not fail during hydro test.
- (c) Teflon tapes shall be used to seal out screwed joints and shall be applied to the male threads only. Threaded parts shall be wiped clean of oil or grease with appropriate solvent if necessary and allowing proper time for drying before applying the sealant. Pipe ends shall be reamed and all chips shall be removed. Screwed flanges shall be attached by screwing the pipe through the flange and the pipe and flange shall be refaced accurately.
- (d) For pipe sizes from 350 mm NB to 550 mm NB (including 350 NB & 550 NB) the GI pipes shall be of flanged connection. However, the pipes after welding of flanges shall be completely galvanized. Any site welding done on galvanized pipes shall be done with zinc-rich special electrodes and the welded surfaces whether inside or outside shall be coated with zinc-silicate paste. Seal welding of flanges with zinc-rich electrode will be permitted only when any flange is leak-prone during hydro testing.
- (e) For pipe sizes 600 mm NB and above, the GI pipes shall be of welded connection (with zinc-rich special electrodes) followed by application of zinc silicate coating at welded surfaces both inside and outside the pipe, except for the last blank/blind flange, or, equipment connection where application of zinc-silicate paste after welding cannot be done due to inaccessibility of the inside welded surface and where galvanic protection has been impaired due to welding of pipe-to-pipe joint. Thus the last erection joint shall be flanged joint.

Welded Joints

For making up welded joints (butt weld or socket weld) the welding shall be performed by manual shielded metal arc process in accordance with the requirements specified elsewhere in the spec. Any welder employed for carrying butt welding shall be qualified as per ASME section IX for the type of joints he is going to weld. Jointing by butt weld, or socket weld shall depend upon the respective piping material specifications

Flanged Joints

- (a) Flanged connections for pipes are to be kept to the minimum and used only for connections to vessel, equipments, flanged valves and other fittings like strainer/traps/orifices etc. for ease of connection and maintenance etc. Rubber lined pipes shall be flange joined only.
- (b) All flanged valves intended for installation on steel piping system, shall have their flanges drilled to ANSI B 16.5 (or equivalent) and according to the pressure class stated in their respective piping material specification.
- (c) Drilling on flanges of flanged valves must correspond to the drilling of flanges on the piping system on which the valves are installed.

Bends/elbows/mitre bends/ Tees/ Reducers & other fittings

For pipe fittings such as elbows (long radius), reducers, tees, etc. the material shall be to ASTM-A-234 Gr. WPB/ASTM-105 up to 300 NB. For pipe fittings above 300 NB, the fittings may be fabricated conforming to parent pipe material. Provision of compensation pads shall be kept as per ANSI B 31.1. The fitting shall conform to the dimensional standard of ANSI B- 16.9/ 16.11. Further branching in pipes for sizes 65nb and above is also acceptable (ANSI B 31.1).

However, for pipes up to 150 NB, pipe fittings may be supplied with material and dimension conforming to IS 1239 in case parent pipes also conform to IS 1239.

For pipe size 350Nb and above mitre bends may be used for all pipes except rubber lined pipes. However, mitre bends are also acceptable for rubber lined pipes above 1200 NB. The bend radius shall be 1½ times the nominal pipe diameter. 90 deg. bends (mitre) shall be in 4 pieces (3 cuts) and 45 deg. mitre bends shall be in 3 pieces 22½ deg. Fabrication of mitre bends shall be as detailed in BS 2633/BS534.

For pipes, above 1200 NB, reducer and tees shall be to dimensional standard of AWWA-C- 208.

Stainless steel fittings shall conform to either ASTM-A-182 Gr. 304 or ASTM-A-403 Grade WP. 304 Class-S, for sizes upto and including 50 mm NB, i.e. the fittings shall be of seamless construction. However, for stainless fittings above 50 mm NB, the same shall conform to ASTM-A-403 Gr. WP 304 Class W i.e. the fittings shall be of welded construction strictly in accordance with ASTM-A-403.

In no case, the thickness of fittings.

Flanges

Flanges shall be slip on type or weld neck type. Welding of flanges in tension is not permitted.

All flanges and-flanged drilling shall be to ANSI B 16.5 / BS EN-1092 / AWWA C - 207 of relevant pressure/temperature class. Flanges shall be fabricated from steel plates conforming to ASTM A 105/IS 2062 Gr. E-250B. However stainless steel flanges shall be fabricated from SS plates to ASTM-A-240, Gr. 304 or equivalent.

Specific technical requirement of laying buried pipe with anti-corrosive treatment

The pipe in general shall be laid with the top of the pipe minimum 1.0 (one) meter below finished general ground level.

Trenching

(a) The trench shall be cut true to the line and level and shall follow the gradient of the pipeline. The width of the trench shall be sufficient to give free working space on each side of the pipe. Trenches shall conform to IS 5822 or any international standard.

Preparation and cleaning of piping

- (a) The pipeline shall be thoroughly cleaned of all rust, grease, dirt, weld scales and weld burrs etc. moisture or other foreign matter by power cleaning method such as sand or grit blasting, power tool cleaning, etc. Grease or heavy oil shall be removed by washing with a volatile solvent such as gasoline. Certain inaccessible portions of the pipeline (which otherwise not possible to be cleaned by power cleaning methods) may be scrubbed manually with a stiff wire brush and scrapped where necessary with specific permission of the Project Manager.
- (b) On the internal surface for pipes 1000 Nb and above, a coat of primer followed by a hot coal-tar enamel or coal tar epoxy painting (cold) shall be applied.

Coating and wrapping/ Anti corrosive Protection Coal tar tape

- a. Buried piping shall be coated and wrapped, as per specification, after completion of welded and/or flanged connections, and after completion and approval of Hydro testing. Materials to be used for coating and wrapping of underground pipelines are:
 - 1. Coating primer (coal tar primer)
 - 2. Coating enamel (coal tar enamel)
 - 3. Wrapping materials.

All primer/coating/wrapping materials and methods of application shall conform to IS: 10221 except asphalt/bitumen material. Materials (primer/coating/wrapping) as per AWWA-C-203 are also acceptable.

Protective coating shall consist of coal tar primer, coal tar enamel coating, glass fiber, tissue inner wrap followed by glass fiber or coal tar impregnated Kraft outer wrap or finish coat.

Number of coats and wraps, minimum thickness for each layer of application shall be as per IS-10221. Number of. Coats and wraps shall be decided based on soil corrosivity/resistivity as indicated in IS-10221. Soil data-for this purpose shall be made available.

Total thickness of completed coating and wrapping shall not be less than 4.0 mm.

- b. Alternatively, the anti-corrosive protection for buried pipes can consist of anticorrosive protection Coal-tar tapes. Material and application of tapes shall conform to IS 15337 or equivalent. These-tapes shall be applied hot over the cold coal tar primer in steps of 2mm thickness so as to cover the spiral edges of the first tape by the application of second tape. The total thickness of the finished protective coating shall be 4.0 mm minimum.

Design/Construction/Material Particulars of Gate/ Globe /Check /Butterfly / Ball / Air release /Float valves / Moisture Traps.

GENERAL

- (a) All valves shall have indicators or direction clearly marked on the hand-wheel so that the valves opening/closing can be readily determined.
- (b) Special attention shall be given to operating mechanism for large size valves with a view to obtaining quick and easy operation ensuring that a minimum of maintenance is required.
- (c) The valves coming in vacuum lines shall be of extended gland type and/or water sealed.
- (d) The actuator-operated valves shall be designed on the basis of the following:
 - (1) The internal parts shall be suitable to support the pressure caused by the actuators;
 - (2) The valve-actuator unit shall be suitably stiff so as not to cause vibrations, misalignments, etc.
 - (3) All actuator-operated valves shall be provided with hand operated gearing mechanism also.
 - (4) All actuators operated valves shall open/ close fully within time required by the process.
- (e) Valves coming under the purview of IBR shall meet IBR requirements.
- (f) All valves shall be provided with embossed name plate giving details such as tag number, type, size etc.
- (g) Wherever required valves shall be provided with chain operator, extension spindles and floor stands or any other arrangement approved by employer so that they can be operated with ease from the nearest operating floor. Wherever necessary for safety purpose locking device shall be provided. Further, necessary small platforms for facilitating easy valve operation shall be provided by the contractor wherever necessary in consultation with project manager within the bid price at no extra cost to employer.

VALVE BODY MATERIAL

Valve body material for various services shall be as follows:

Valve body material for water application like Secondary circuit auxiliary cooling water of ECW system, clarified water, DM cooling water (pH corrected) , drinking water etc. shall be cast iron for sizes 65NB and above; gun-metal for sizes 50 Nb and below.

For compressed air application, valve body material shall be cast carbon steel or forged carbon steel for sizes 65 mm NB & above and Gun metal for sizes 50 NB and below.

DM water: SS body and disc along with SS internals. However for butterfly valves, Cast Iron /Ductile Iron/SG iron/carbon steel body and disc with elastomer lining are also acceptable.

The design, material, construction, manufacture, inspection, testing and performance of valves shall comply with all currently applicable statutes, regulations and safety codes in the locality where the valves will be installed. The valves shall conform to the latest editions of applicable codes and standards as mentioned elsewhere. Nothing in this specification shall be construed to relieve the Bidder of his responsibility. Valves in general shall conform to the requirements of the following standards.

Standards and Codes

AWWA-C-504	Rubber seated butterfly valves.
BS-5155/EN-593	Cast iron and steel body butterfly valves for general purpose.
IS-778	Gun-metal gate, globe and check valves for general purpose.
BS-5154	Copper alloy globe/globe stop and check and gate valves for general purpose.
IS-780	Sluice valves for water works purpose (50-300 mm size)
IS-2906	Sluice valves for water works purpose (350-1200 mm size)
IS-5150	Cast iron wedge and double disc gate for general purpose.
BS-5152	Specification for cast iron globe valves.
BS-5153	Cast iron check valves for general purpose.
IS-5312	Swing check type reflux (non-return) valves.
ANSI B 16.34	Standard for valves.
API-594	Standard for Dual-check valves.
API-600	Steel gate valves.
ANSI-B-16.10	Valves face to face and other relevant dimension.
API-598	Valves inspection test.

End Connections

The end connections, shall comply with the following:

Socket welding (SW) - ANSI B 16.11

Butt Welding (BW) - ANSI B 16.25.

Threaded (SC) - ANSI B 2.1

Flanged (FL) - ANSI B 16.5& AWWA-C-207 (steel flanges), ANSI B 16.1 (Cast Iron flanges).

Gate/Globe/Check Valves

- (a) All cast iron body valves (gate, globe and non-return) shall have flanged end connections; (screwed ends for Ductile D.2NI body valves are not acceptable).
- (b) All steel and stainless steel body valves of sizes 65 mm and above shall have flanged or butt welding ends. Valves of sizes below 65mm shall have flanged or socket welded ends. Compatibility of welding between valve body material and connecting pipe material is a pre-requisite in case of butt-welded joints.
- (c) All gun metal body valves shall have screwed ends.
- (d) All flanged end valves/specialties. shall be furnished along with matching counter flanges, fasteners, gaskets etc. as required to complete the joints.
- (e) Gate/sluice valves shall be used for isolation of flow. All gate valves shall be of the full-way type, and when in the full open position the bore of the valve shall not be constricted by any part of the gate.

Gate valves shall be of the solid/elastic or articulated wedge disc. Gate valves shall be provided with the following accessories in addition to other standard items:

- (1) Hand wheel
 - (2) Position indicator (for above 50 mm NB valve size)
 - (3) Draining arrangement wherever required.
- (f) Globe valves shall be used for regulation purposes. They shall be provided with hand wheel, position indicator, draining arrangement (wherever required) and arrow indicating flow direction. Preferably, the valves shall be of the vertical stem type. Globe valves shall preferably have radiused or spherical seating and discs shall be free to revolve on the spindle. The pressure shall preferably be under the disc of the valve. However, globe valves, with pressure over the disc shall also be accepted provided (i) no possibility exists that flow from above the disc can remove either the disc from stem or component from disc (ii) manual globe valves can easily be operated by hand. If the fluid load on the top of the disc is higher than 40-60 KN, bypass valve shall be provided which permits the downstream system to be pressurized before the globe valve is opened.
- (g) Check valves shall be used for non-return service. They shall be swing check type or double door (Dual plate) check type with a permanent arrow inscription on the valve body indicating the fluid flow direction. In long distance pipes lines with possibility of surge-occurrence, dual plate check valves are preferable for its spring controlled opening /closing of flaps/doors against flow reversals. However, dual plate check valves shall not be used for sizes more than 600mm NB.
- (h) For bore greater than 2" the valves must be swing check type or dual plate check type suitable for installation in all positions (vertical and horizontal);
- (i) For bore smaller than or equal to 2" the valves must be of the piston type to be installed, in horizontal position.
- (j) All gate and globe valves shall be provided with back seating arrangement to enable on line changing of gland packing. The valves shall be preferably outside screw & yoke type.
- (k) All gate and globe valves shall be rising stem type and shall have limit switches for full OPEN and full CLOSED indication wherever required. This will include motor operated valves also wherever required. In such cases the limit switches shall form an integral part of the valve. Stop-gap arrangement in this respect is not acceptable.
- (l) All valves except those with rising stems shall be provided with continuous mechanical position indicators; rising stem valves shall have only visual indication through plastic/metallic stem cover for sizes above 50 mm nominal bore
- (m) For Cl gate, globe and check valves wherever thickness of body/bonnet is not mentioned in the valves standards, thickness mentioned in IS- 1538 for fitting shall be applicable.

MATERIAL OF CONSTRUCTION (GATE/GLOBE/CHECK VALVE)

(a) The materials shall generally comply with the following:

(1) Cast Steel Valves

Body & bonnet	ASTM A 216 Gr. WCB/ ASTM A 105
Disc for non-return Valves	ASTM A 216 Gr. WCB/ ASTM A 105
Trim.	ASTM A 182 Gr. F6 or Equivalent

(2) Stainless steel valves

Body & Bonnet	SS 304
Disc	-do-
Trim.	SS 316

(3) Cast iron valves

Body & bonnet	BS 1452 Gr. 14/ IS-210 Gr. FG 260
Seating surfaces and rings	13% chromium steel/ 13% Chrome overlay
Disc for non-return valves	BS 1452 Gr. 14/IS-210 Gr FG 260
Hinge pin for non-return valves	AISI 316
Stem for gate globe valves	13% chromium steel or Equivalent
Back seat	13 % chromium steel / 13% Chrome overlay

(4) Gun Metal valves

Body and bonnet	IS 318 Gr. 2/ Equivalent Standard
Trim.	-do-

(b) Cast iron body valves shall have high alloy steel stem and seat.

(c) Material for counter flanges shall be the same as for the piping.

(d) Forged carbon steel valves are also acceptable in place of Gun metal valves.

Butterfly valves

Design/Construction

(a) The valves shall be designed for the design pressure/temperature of the system on which it is installed and in accordance with AWWA-C-504, EN-593 or any other approved equivalent standard latest edition. Fabricated steel (IS: 2062 GR. E-250B) butterfly valves instead of cast iron body valves are also acceptable for size above 300 mm nb diameter.

(b) The valves shall be suitable for installation in any position (horizontal/vertical etc.) and shall be generally of double-flanged construction. However for sizes 600 NB and below the valves of Wafer construction are also acceptable.

(c) Valves-350Nb and above shall have pressure equalizing bypass valves, wherever system parameters warrant the same.

(d) Valves-200Nb and above shall also be provided with gear operator arrangement as a standard practice suitable for manual operation. Manual operation of valve shall be through gear arrangement having totally enclosed gearing with hand wheel diameter and gear ratio designed to meet the required operating torque It shall be designed to hold the valve disc in intermediate position between full open and full closed position without creeping or fluttering. Adjustable stops shall be provided to prevent over travel in either direction.

Limit and torque switches (if applicable) shall be enclosed in water tight enclosures along with suitable space heaters for motor actuated valves, which may be either for On-Off operation or inching operation with position transmitter.

Material of Construction (Butterfly Valves)

Materials and other design details shall be as indicated below:

(a) Cast Iron Butterfly Valves

Body & Disc	ASTM A48, Gr. 40 with 2% Ni / IS: 210. Gr. FG-260, with 2% Ni / SG iron BSEN 1563, Gr EN GJS-400-15 with 2%Ni and epoxy coated
Shaft	BS 970 431 S: 291 / EN 57, or AISI-410 or AWWA-permitted shaftmaterial equivalent to EN-57/AISI-410 or better
Seat ring	18-8 Stainless steel
Seal	Nitrile Rubber

(b) Stainless Steel Butterfly Valves

Body & Disc	SS 304
Shaft	SS 316
Seat Rings	EPT/BUNA-N/Neoprene

(c) Carbon steel Butterfly Valves

Body & Disc	ASTM A 216, Gr. WCB
Shaft	SS 304
Disc & Seat Rings	EPT/BUNA-N/Neoprene

(d) Elstomer lined Butterfly Valves

Body & Disc ASTM A48, Gr. 40 / IS: 210. Gr. FG-260 / SG Iron (ductile iron) IS 1865 Gr 400-15 or BSEN 1563, Gr EN GJS-400-15 / ASTM A 216, Gr. WCB with elastomer lining.

Shaft **SS 316**

Proof of Design Test (Type Test) for Butterfly Valves

Proof of Design (P.O.D.) test certificates shall be furnished by the bidder for all applicable size-ranges and classes of Butterfly valves supplied by him, in the absence of which actual P.O.D. test shall be conducted by the bidder. All valves that are designed and manufactured as per AWWA-C-504 / AWWA-C-516 shall be governed by the relevant clauses of P.O.D test in AWWA-C-504/AWWA-C-516. For Butterfly valves, designed and manufactured to EN-593 or equivalent, the P.O.D. test methods and procedures shall generally follow the guidelines of AWWAC- 504 in all respect except that Body & seat hydro test and disc-strength test shall be conducted at the pressures specified in EN-593 or the applicable code. Actuators shall also meet requirements of P.O.D. test of AWWA-C-504/AWA-C-516.

Float operated valves

- (a) Valve shall automatically control the rate of filling and will shut off when a predetermined level is reached and close to prevent over flow on pre-set maximum water level. Valve shall also open and close in direct proportion to rise or fall of water level.

(b) DESIGN AND CONSTRUCTION FEATURES

The following design and construction feature of the valve shall be the minimum acceptable.

- (c) Valves shall be right-angled or globe pattern.
- (d) Valves shall be balance piston type with float ball.
- (e) Leather liner shall not be provided.
- (f) The body and cover material shall be cast iron conforming to ASTM-A 126 Grade 'B' or IS: 210 Grade 200 or equivalent, and Float shall be of copper with epoxy painting of two (2) coats.
- (g) Valves shall be suitable for flow velocities of 2 to 2.5 m/sec.
- (h) The valves shall have flanged connections.

Surface preparation and Painting for external piping surfaces (non-coastal projects)

- a) Surface preparation - Power tool cleaning / Shot blasting/ abrasive blasting.
- b) Type of Primer - Red Oxide Zinc Phosphate primer (Alkyd base) to IS 12744 (2 X 25 microns)
- c) Intermediate Coat – Synthetic Enamel (long oil alkyd) to IS2932 (1 X 30 microns)
- d) Final Coat - Synthetic Enamel (long oil alkyd) to IS2932 (2 X 35 microns)

Min. Total DFT (Microns) to be maintained – 150 (Min) and Color shall be as per NTPC Color Coding Scheme.

Note: No painting is required on Galvanized, Stainless Steel, Gun Metal surfaces

TECHNICAL REQUIREMENTS OF CONTROL VALVES, ACTUATORS & ACCESSORIES

CONTROL VALVES, ACTUATORS & ACCESSORIES

1. General Requirements

- The control valves and accessories equipment furnished by the Bidder shall be designed, constructed and tested in accordance with the latest applicable requirements of code for pressure piping ANSI B 31.1, the ASME Boiler & pressure vessel code, Indian Boiler Regulation (IBR), ISA, and other standards specified elsewhere as well as in accordance with all applicable requirements of the “Federal Occupational Safety and Health Standards, USA” or acceptable equal standards. All the Control Valves, their actuators and accessories to be furnished under this Sub-section will be fully suitable and compatible with the modulating loops covered under the Specification.
- All the control valves and accessories offered by the Bidder shall be from reputed, experienced manufacturers of specified type and range of valves.

2. CONTROL VALVE SIZING & CONSTRUCTION

- The design of all valve bodies shall meet the specification requirements and shall conform to the requirements of ANSI (USA) for dimensions, material thickness and material specification for their respective pressure classes.
- The valve sizing shall be suitable for obtaining maximum flow conditions with valve opening at approximately 80% of total valve stem travel and minimum flow conditions with valve stem travel not less than 10% of total valve stem travel. All the valves shall be capable of handling at least 120% of the required maximum flow. Further, the valve stem travel range from minimum flow condition to maximum flow condition shall not be less than 50% of the total valve stem travel. The sizing shall be in accordance with the latest edition of ISA handbook on control valves. While deciding the size of valves, Bidder shall ensure that valves outlet velocity as defined in ISA handbook does not exceed 8 m/sec for liquid services, 150 m/sec. for steam services and 50% of sonic velocity for flashing services. Bidder shall furnish the sizing calculations clearly indicating the outlet velocity achieved with the valve size selected by him as well as

noise calculations, which will be subject to Employer's approval during detailed engineering.

- Control valves for steam and water applications shall be designed to prevent cavitation, wire drawing, flashing on the downstream side of valve and downstream piping. Thus for cavitation/flashing service, only valve with anti-cavitation trim shall be provided. Detailed calculations to establish whether cavitation will occur or not for any given application shall be furnished.
- Control valve shall have leakage rate as per leakage Class V.
- The control valve induced noise shall be limited to 85 dBA at 1 meter from the valve surface under actual operating conditions. The noise abatement shall be achieved by valve body and trim design and not by use of silencers

3. VALVE CONSTRUCTION

- All valves shall be of globe body design & straightaway pattern with single or double port, unless otherwise specified or recommended by the manufacturer to be of angle body type. Rotary valve may alternatively be offered when pressure and pressure drops permit.
- Valves with high lift cage guided plugs & quick-change trims shall be supplied.
- Cast Iron valves are not acceptable.
- Bonnet joints for all control valves shall be of the flanged and bolted type or other construction acceptable to the Employer. Bonnet joints of the internal threaded or union type will not be acceptable.
- Plug shall be of one-piece construction cast, forged or machined from solid bar stock. Plug shall be screwed and pinned to valve stems or shall be integral with the valve stems.
- All valves connected to vacuum on downstream side shall be provided with packing suitable for vacuum applications (e.g. double vee type chevron packing)
- Valve characteristic shall match with the process characteristics.
- Extension bonnets shall be provided when the maximum temperature of flowing fluid is greater than 280 deg. C.
- Flanged valves shall be rated at no less than ANSI press class of 300 lbs.

4. VALVE MATERIALS

Refer mechanical sections for [PUKR1] body and trim materials. The exact body and trim materials shall be finalised during detail engineering depending in the service applications.

However, bidder may offer valves with body and trim materials better than specified materials and in such case bidder shall furnish the comparison of properties including cavitation resistance, hardness tensile strength, strain energy, corrosion resistance and erosion resistance etc., of the offered material vis-à-vis the specified material for employers consideration and approval.

5. END PREPARATION

Valve body ends shall be either butt welded/socket welded, flanged (Rubber lined for condensate service) or screwed as finalized during detailed engineering and as per Employer's approval. The welded ends wherever required shall be butt welded type as per ANSI B 16.25 for control valves of sizes 65 mm and above. For valves size 50 mm and below welded ends shall be socket welded as per ANSI B 16.11. Flanged ends wherever required shall be of ANSI pressure-temperature class equal to or greater than that of the control valve body.

6. VALVE ACTUATORS

All control valves shall be furnished with pneumatic actuators except for pressure and temperature control valve for auxiliary PRDS application (electro-hydraulic / pneumatically operated) and separator drain control valve (electro-hydraulic type). The Bidder shall be responsible for proper selection and sizing of valve actuators in accordance with the pressure drop and maximum shut off pressure and leakage class requirements. The valve actuators shall be capable of operating at 60 deg.C continuously.

Valve actuators and stems shall be adequate to handle the unbalanced forces occurring under the specified flow conditions or the maximum differential pressure specified. An adequate allowance for stem force, at least 0.15 Kg/sq.cm. per linear millimeter of seating surface, shall be provided in the selection of the actuator to ensure tight seating unless otherwise specified.

The travel time of the pneumatic actuators shall not exceed 10 seconds.

7. CONTROL VALVE ACCESSORY DEVICES

All pneumatic actuated control valve accessories such as air locks, hand wheels/hand-jacks, limit switches, microprocessor based electronic Positioner, diffusers, external volume chambers, position transmitters (capacitance or resistance type only), reversible pilot for Positioner, tubing and air sets, solenoid valves and junction boxes etc. shall be provided as per the requirements.

SPECIFICATIONS FOR MICROPROCESSOR BASED ELECTRONIC POSITIONER

1	Electrical	a) Input Demand Signal	(i) 4-20mA for conventional positioners. (ii) Demand signal would be received through fieldbus network for fieldbus based positioners.
		b) Power Supply	i) Loop powered from the output card of Control System for conventional positioners. (ii) Fieldbus based positioners shall be powered from the fieldbus network.
		c) Protocol	(i) Conventional positioners shall be compatible to HART Protocol (ii) Fieldbus based positioners shall be compatible to Foundation fieldbus/ Profibus depending on the Protocol which is finalized for DDCMIS.
		d. Valve position sensing	(i) Position sensing 4-20 mA output signal to be provided for Control System for conventional positioners. (ii) Valve position feedback shall be available to Control system through fieldbus network for Fieldbus based positioners.
2	Environment	a) Operating temp.	(-)30 To 80 Deg. C
		b) Humidity	0-95 %
		c) Protection class	IP-65 Minimum
3	Software for Configuration and Diagnostics	Software	Software shall meet the requirements for Configuration, Diagnostics, Calibration and Testing of the actuator.
		Diagnostic/Test features	Advanced diagnostic features like Stroke counter or Travel counter, Leakage in actuators, Valve Signature analysis, Step Response test, Valve friction /Jamming detection etc to be provided.
4	Test reports/ Certificates	Factory Valve Signature Tests Reports (Pr Vs Valve travel and Travel Vs I/P signal) are to be provided.	

		Test certificates as per Manufacture Standard/Relevant Standard are to be submitted.	
5	Configuration/ Calibration.	Remote & Local Calibration, Auto & Manual Calibration shall be possible.	
6	Operating Range	Full range/ Split range.	
7	Modes	Valve Action	Direct / Reverse Valve Action
		Flow Characterization	Possible to fit Valve Characteristic Curves-Linear , Equal percentage etc.
8	Fail Safe/Fail Freeze	Fail Safe/Fail Freeze feature is to be provided. (In case the fail freeze feature is not intrinsic to the positioner, Bidder shall achieve the same externally through solenoid valve connected in the pneumatic circuit).	
9	Pneumatic	Air capacity	Sufficient to handle the valves & actuators selected/ Boosters to be supplied, if required.
		Air pressure	To suit the air supply pressure/quality available.
		Process connection	¼" NPT
10	Performance	Characteristic deviation	<=0.5 % of span.
		Ambient temp effect	<=0.01 %/ deg C or better.
10	EMC & CE Compliance	Required to International Standard like EN/IEC.	EN50081-2 & EN50082 or equivalent.
11	Accessories	In-built Operator Panel	Display with push buttons for configuration and display on the positioner itself (Password protected/Hardware lock).
		Hand Held Calibrator	(i) Universal HART Calibrator to be provided for conventional positioners. (for quantity, refer Part-A. Contract

			quantities of the specification). (ii) Fieldbus compatible calibrator to be provided for fieldbus based positioners. (for quantity, refer Part-A)
		Press Gauge Block	For supply & output pressures, Air Filter Regulator and other accessories shall be provided on as required basis for making system complete.
		Electrical Cable Entry	1/2"NPT, side or bottom entry to avoid water ingress.
		Valves Mounting Assembly	For Sliding Stem/Rotary/Single acting/Double acting actuators on as required basis

*** Note:**

The HART signals shall be picked up from marshalling terminals of DDCMIS (SG/TG DDCMIS as well as BOP DDCMIS), as applicable. The details of the above mentioned HART management system specification are mentioned in HART system.

The conventional positioners shall be monitored from this HART management system. The fieldbus based positioners shall be monitored directly through fieldbus based DDCMIS network. To achieve this, Bidder shall provide the necessary software to achieve the functionalities described above under "Software for Configuration and Diagnostics", and this software shall be loaded in the HART management system.

8. TEST AND EXAMINATION

All valves shall be tested in accordance with the quality assurance programme agreed between the Employer and Contractor, which shall meet the requirements of IBR and other applicable codes mentioned elsewhere in the specifications. The tests shall include but not be limited to the following:

- Non Destructive Test as per ANSI B-16.34.
- Hydrostatic shell test in accordance with ANSI B 16.34 prior to seat leakage test.

- Valve closure test and seat leakage test in accordance with ANSI-B 16.34/ FCI 70.2 standard and as per the leakage class indicated above
- Functional Test: The fully assembled valves including actuators control devices and accessories shall be functionally tested to demonstrate times from open to close position.
- CV Test: Please refer CI No. 1.00.00 & 3.00.00 OF Sub-section- IIC-10 (Type test requirements), Control Valves.

Bidder shall furnish all the control valves under this main plant package as finalized during detailed engineering stage without any price repercussions whatsoever depending on the process requirements. All the control valves provided by the Bidder for this project shall meet the specifications requirements specified herein. Specification for control valves in this Sub-section has to be read in conjunction with other relevant Sub-sections of this specification.

	DEVELOPMENT CONSULTANTS PRIVATE LIMITED
Reviewed only for general performance with contract drawings and specifications.	
ACTION - 5	
1 Approved	4 Disapproved
1* Approved with Comments	
2 Approved except as noted, Forward final drawing.	5 For information and record with comments.
3 Approved except as noted, Resubmission required.	3 For information and Record.
Contractor to be responsible for any error and for fulfillment of detailed requirements of contract documents.	

REV	DATE	DESCRIPTION /NOTE	PRD	CHD	APD
03	24.02.22	Revised the document as per the comments	KMK	PR	PNR
02	26.11.21	Revised the document as per the comments	KMK	PR	PNR
01	19.05.20	Modified as per Latest discussions with TS GENCO	KMK	PR	PNR
00	09.05.19	Fresh Issue	KMK	PR	VK

REVISIONS

TITLE:
P&ID_LIMESTONE GRINDING SYSTEM

OWNER/PROJECT: **TELANGANA STATE POWER GENERATION CORPORATION LTD**
 **KOTHAGUDEM (1X800 MW) THERMAL POWER PLANT- FGD SYSTEM PACKAGE**

CONSULTANT:
 **DEVELOPMENT CONSULTANTS PRIVATE LIMITED KOLKATA**

EPC CONTRACTOR:
 **BHARAT HEAVY ELECTRICALS LTD. BOILER AUXILIARIES PLANT, RANIPET**
Maharatna Company

COLLABORATOR
 **MITSUBISHI HITACHI POWER SYSTEMS, LTD AIR QUALITY CONTROL SYSTEMS TECHNOLOGY DIVISION**

	BHEL	Date	
PREPARED BY	Kabilash	24.02.22	STATUS : FOR APPROVAL
CHECKED BY	Raju Puram	24.02.22	BHEL CUST NO : G801
APPROVED BY	Naveen	24.02.22	BHEL DOC NO: 03-FW-734-00598
			REV NO :03

LINE SYMBOLS

SYMBOLS	NAME
	PIPE LINE
	CAPILLARY TUBING
	ELECTRIC SIGNAL
	SOFTWARE LINK
	PRESSURE LEAD
	DUCT

PIPING VALVE SYMBOLS

SYMBOLS	NAME
	GATE VALVE (NOR.CLOSED)
	GLOBE VALVE (NOR.CLOSED)
	BALL VALVE (NOR.CLOSED)
	BUTTERFLY VALVE (NOR.CLOSED)
	DIAPHRAGM VALVE (NOR.CLOSED)
	PINCH VALVE (NOR.CLOSED)
	NEEDLE VALVE (NOR.CLOSED)
	CHECK VALVE
	CHECK VALVE (WAFER)
	PRESSURE RELIEF VALVE

INSTRUMENT VALVE SYMBOLS

SYMBOLS	NAME
	ACTUATED BY AIR
	ACTUATED BY MOTOR
	ACTUATED BY MOTOR (INCHING)
	AIR CONTROL VALVE
	SOLENOID ACTUATOR
	SELF REGULATING VALVE
	SELF REGULATING VALVE

TRENCH SYMBOLS

SYMBOLS	NAME
	TO ABSORBER AREA DRAIN SUMP
	TO GYPSUM AREA DRAIN SUMP
	TO LIMESTONE AREA DRAIN SUMP

SYMBOLS FOR PIPING PARTS & INSTRUMENT PARTS

SYMBOLS	NAME
	STEAM TRAP
	AIR TRAP
	Y-STRAINER
	T-STRAINER
	TEMPORARY STRAINER
	REDUCER
	EXPANSION JOINT
	DUCT EXPANSION JOINT
	FLEXIBLE HOSE
	SPOOL PIECE
	VENT
	HOSE CONNECTION
	BLIND FLANGE
	REDUCING FLANGE
	CAP (BW)
	CAP (SCR)
	TRENCH
	SIGHT GLASS
	SILENCER
	ORIFICE
	DIAPHRAGM
	MAGNETIC FLOW METER
	VORTEX FLOW METER
	PH METER
	FILTER
	MANHOLE
	INSPECTION HOLE
	PITOT TUBE
	SAMPLING POT
	SAMPLING NOZZLE
	RESTRICTION ORIFICE
	ROTOMETER TYPE FLOW METER

SYMBOLS FOR VALVE OPERATION

SYMBOLS	NAME
	FAILURE OPEN (THE VALVE OPENS WHEN AIR OR ELECTRICITY FOR ACTUATOR FAILS.)
	FAILURE CLOSE (THE VALVE CLOSES WHEN AIR OR ELECTRICITY FOR ACTUATOR FAILS.)

INSULATION SYMBOLS

SYMBOLS	DESCRIPTION
H10	THERMAL INSULATION (100°C & LOWER)
H15	THERMAL INSULATION (101°C ~ 150°C)
H20	THERMAL INSULATION (151°C ~ 200°C)
H25	THERMAL INSULATION (201°C ~ 250°C)
H30	THERMAL INSULATION (251°C ~ 300°C)
H35	THERMAL INSULATION (301°C ~ 350°C)
HF	INSULATION FOR ANTI FREEZING
ET	ELECTRIC TRACE
ST	STEAM TRACE (LOW PRESSURE STEAM)
P10	PERSONAL PROTECTION (100°C & LOWER)
P15	PERSONAL PROTECTION (101°C ~ 150°C)
P20	PERSONAL PROTECTION (151°C ~ 200°C)
P25	PERSONAL PROTECTION (201°C ~ 250°C)
P30	PERSONAL PROTECTION (251°C ~ 300°C)
P35	PERSONAL PROTECTION (350°C ~ 400°C)

DELIVERY LIMITS

SYMBOLS	NAME
	BETWEEN CLIENT AND CONTRACTOR
	BETWEEN SUB CONTRACTOR AND VENDOR

SYSTEM

NUMBER	NAME
1	FLUE GAS SYSTEM
2	SO ₂ ABSORPTION OXIDATION SYSTEM
3	REHEATING SYSTEM
4	GYPSUM DEWATERING HANDLING SYSTEM
5	LIMESTONE PREPARATION SYSTEM
6	BLANK
7	SUMP SYSTEM
8	UTILITY SYSTEM

FLUID NAME

FLUID SYMBOL	FLUID NAME	FLUID SYMBOL	FLUID NAME
AA	ANTIFOAM AGENT	WCS	COOLING WATER SUPPLY
AC	COMPRESSED AIR	WCR	COOLING WATER RETURN
AF	FLUIDIZER AIR	WC	Ca(OH) ₂
AI	INSTRUMENT AIR	WP	PROCESS WATER
AO	OXIDATION AIR	WR	RAW WATER
AS	SEAL AIR	WW	WASTE WATER
DD	DUCT DRAIN	VG	VACUUM PUMP VENT
FS	FILTRATE SLURRY	VBG	BELT FILTER VENT GAS
GS	GYPSUM SLURRY	LD	LIMESTONE DEDUSTING
LS	LIMESTONE SLURRY	LOL	LUBE OIL (LOW PRESSURE)
FG	FLUE GAS	LOH	LUBE OIL (HIGH PRESSURE)

SERVICE CLASS

SERVICE CLASS	MATERIAL	FLUID SYMBOL
AA40	IIR RUBBER LINED PIPING	LS, WP, WC
AA60	IIR RUBBER LINED PIPING	GS,FS,WW,DD
BA01	Gr.304 STAINLESS STEEL / GI PIPING	AI, LOL
BA02	Gr.304 STAINLESS STEEL / GI PIPING	LOH
BA03	Gr.316L STAINLESS STEEL PIPING	WP, AO
CA01	CARBON STEEL GENERAL PIPING	AS,AO,AC,AF,LD
CC01	CARBON STEEL PRESSURE PIPING	WP,WR,WCS,WCR, VG, AA
DA60	FRP PIPING (PIPE DIA UPTO 400 NB)	GS,FS,WW,DD
DA40	FRP PIPING (PIPE DIA UPTO 400 NB)	LS, WP, WC

UNIT CODE

SYMBOLS	UNIT IDENTIFICATION
00	COMMON
10	UNIT-1 FGD SYSTEM AND AUXILIARIES

EXPRESSION OF PIPING LINE

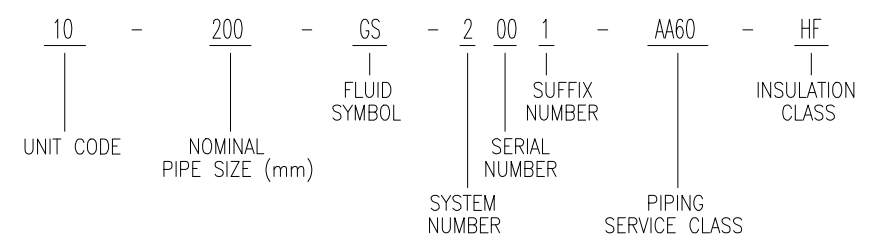

CUSTOMER NOS:G801

CUSTOMER: TSGENCO.
PROJECT: KTPS 1X800 MW FGD SYSTEM PACKAGE

DEPT	NAME (INEL)	DATE
CODE	KM.KABILASH	04.03.21
M	P.RAJU	04.03.21
APPD	PNR/ACR/RSB	04.03.21

MITSUBISHI HITACHI POWER SYSTEMS, LTD.
AIR QUALITY CONTROL SYSTEMS TECHNOLOGY DIVISION

SCALE : NTS

TITLE: P & ID - SYMBOL MARK (1/2)

FILE NO 03-FW-000-00605

REV NO 00



INSTRUMENT ABBREVIATION

	FIRST-LETTER		SUCCEEDING-LETTERS		
	MEASURED OR INITIATING VARIABLE	MODIFIER	READOUT OR PASSIVE FUNCTION	OUTPUT FUNCTION	MODIFIER
A	ANALYSIS		ALARM		
B	BURNER, COMBUSTION		BLANK	BLANK	BLANK
C	BLANK			CONTROL	
D	BLANK	DIFFERENTIAL			
E	VOLTAGE		SENSOR (PRIMARY ELEMENT)		
F	FLOW RATE	RATIO (FRACTION)			
G	BLANK		GLASS, VIEWING DEVICE		
H	HAND				HIGH
I	CURRENT (ELECTRICAL)		INDICATE		
J	POWER	SCAN			
K	TIME, TIME SCHEDULE	TIME RATE OF CHANGE		CONTROL STATION	
L	LEVEL		LIGHT		LOW
M	BLANK	MOMENTARY			MIDDLE, INTERMEDIATE
N	BLANK		BLANK	BLANK	BLANK
O	BLANK		ORIFICE, RESTRICTION		
P	PRESSURE, VACUUM		POINT (TEST) CONNECTION		
Q	QUANTITY	INTEGRATE, TOTALIZE			
R	RADIATION		RECORD		
S	SPEED, FREQUENCY	SAFETY		SWITCH	
T	TEMPERATURE			TRANSMIT	
U	MULTIVARIABLE		MULTIFUNCTION	MULTIFUNCTION	MULTIFUNCTION
V	VIBRATION, MECHANICAL ANALYSIS			VALVE, DAMPER, LOUVER	
W	WEIGHT, FORCE		WELL		
X	UNCLASSIFIED	X AXIS	UNCLASSIFIED	UNCLASSIFIED	UNCLASSIFIED
Y	EVENT, STATE OR PRESENCE	Y AXIS		RELAY, COMPUTE, CONVERT	
Z	POSITION, DIMENSION	Z AXIS		DRIVER, ACTUATOR, UNCLASSIFIED FINAL CONTROL ELEMENT	

INSTRUMENT SYMBOLS

SYMBOLS	NAME
	FIELD MOUNTED
	FOR CONTROL ROOM
	FOR LOCAL CONTROL PANEL
	FOR DCS
	INTERLOCK LOGIC

PNEUMATIC VALVE ACTUATOR

CODE NO.	ACTUATION
FLXXWA-D	DOUBLE SOLENOID NO LIMIT SWITCH
FLXXWA-DL	DOUBLE SOLENOID WITH LIMIT SWITCH
FLXXWA-S	SINGLE SOLENOID NO LIMIT SWITH
FLXXWA-SL	SINGLE SOLENOID WITH LIMIT SWITCH

MACHINERY SYMBOLS

SYMBOLS	NAME
	PUMP
	FAN / BLOWER
	AGITATOR (FLAT BLADE)
	AGITATOR (PROPELLOR)
	ROTARY VALVE
	CRUSHER
	BELT FEEDER
	BELT FILTER
	BALL MILL
	CYCLONE
	MIST ELIMINATOR

EQUIPMENT SYMBOLS

SYMBOLS	NAME
	BAG FILTER
	SILO
	SLIDE GATE
	TANDEM LOUVER DAMPER (MULTIVANE)
	SINGLE STAGE LOUVER DAMPER (MULTIVANE)
	LOUVER DAMPER (SINGLE VANE)
	DISTRIBUTION BOX (3WAY)
	DISTRIBUTION BOX (2WAY)
	SUMP
	HEAT EXCHANGER
	SHELL AND TUBE HEAT EXCHANGER
	AIR DRYER
	FILTER
	SPRAY NOZZLE

DRIVER SYMBOLS

SYMBOLS	NAME
	AIR MOTOR
	ELECTRIC MOTOR

OTHER SYMBOLS

SYMBOLS	NAME
	INSERT PIPE / LANCE
	CHUTE
	TRUCK



CUSTOMER NOS:G801

CUSTOMER: TSGENCO.
PROJECT: KTPS 1X800 MW FGD SYSTEM PACKAGE

DEPT	NAME (BHEL)	DATE
CODE	KM.KABILASH	04.03.21
M	P.RAJU	04.03.21
APPD	PNR/ACR/RSB	04.03.21

MITSUBISHI HITACHI POWER SYSTEMS, LTD.
AIR QUALITY CONTROL SYSTEMS TECHNOLOGY DIVISION

SCALE : NTS

TITLE: P & ID - SYMBOL MARK (2/2)

FILE NO 03-FW-000-00605

REV NO 00

CAUTION: THIS DRAWING IS THE PROPERTY OF BHEL AND IS NOT TO BE REPRODUCED OR USED TO FURNISH ANY INFORMATION FOR MAKING OF DRAWINGS OF APPARATUS EXCEPT THOSE PROVIDED BY APPOINTMENT WITH AND UNDER

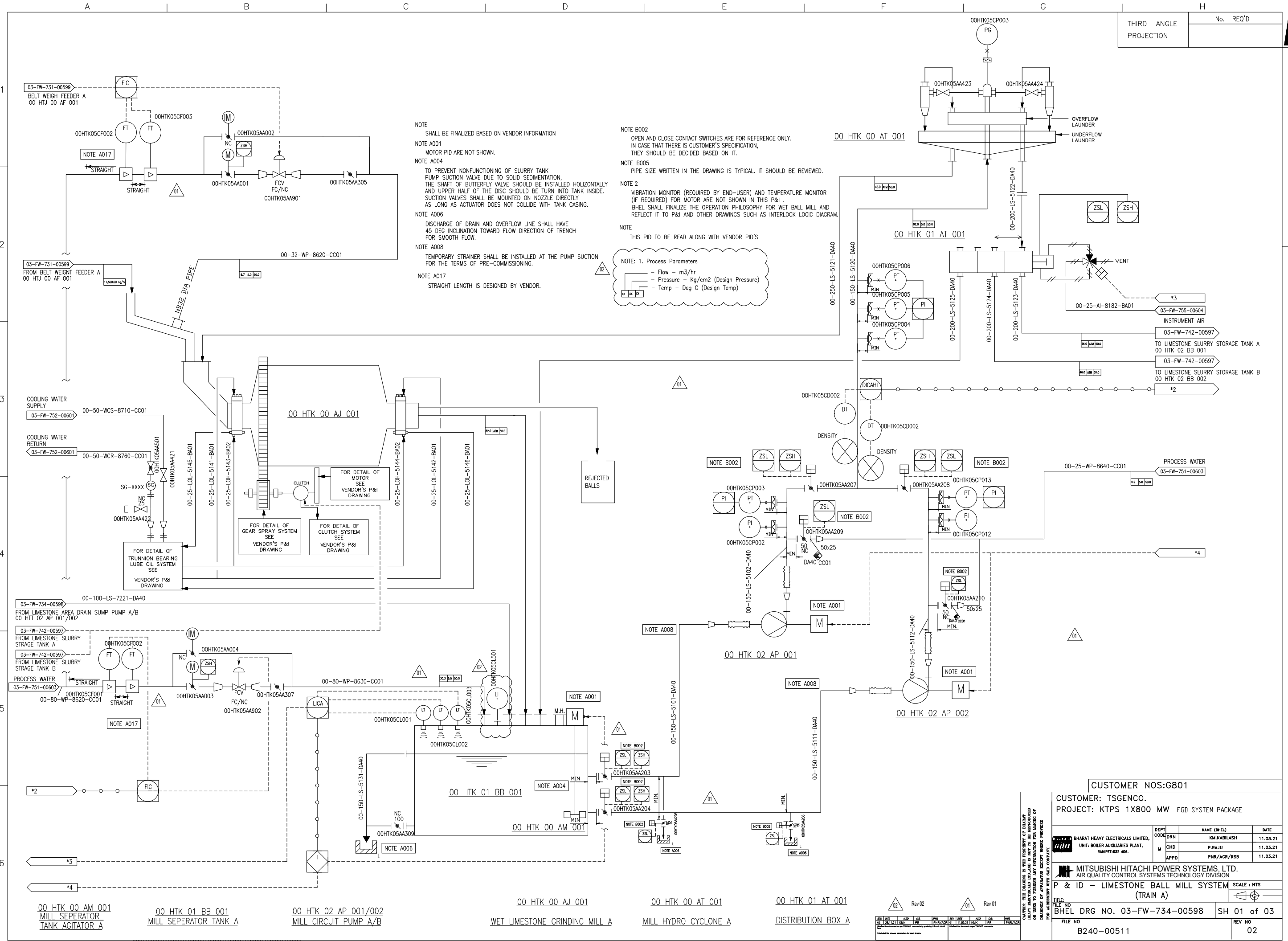

NOTE
SHALL BE FINALIZED BASED ON VENDOR INFORMATION

NOTE A001
MOTOR PID ARE NOT SHOWN.

NOTE A004
TO PREVENT NONFUNCTIONING OF SLURRY TANK PUMP SUCTION VALVE DUE TO SOLID SEDIMENTATION, THE SHAFT OF BUTTERFLY VALVE SHOULD BE INSTALLED HORIZONTALLY AND UPPER HALF OF THE DISC SHOULD BE TURN INTO TANK INSIDE. SUCTION VALVES SHALL BE MOUNTED ON NOZZLE DIRECTLY AS LONG AS ACTUATOR DOES NOT COLLIDE WITH TANK CASING.

NOTE A006
DISCHARGE OF DRAIN AND OVERFLOW LINE SHALL HAVE 45 DEG INCLINATION TOWARD FLOW DIRECTION OF TRENCH FOR SMOOTH FLOW.

NOTE A008
TEMPORARY STRAINER SHALL BE INSTALLED AT THE PUMP SUCTION FOR THE TERMS OF PRE-COMMISSIONING.

NOTE A017
STRAIGHT LENGTH IS DESIGNED BY VENDOR.

NOTE B002
OPEN AND CLOSE CONTACT SWITCHES ARE FOR REFERENCE ONLY. IN CASE THAT THERE IS CUSTOMER'S SPECIFICATION, THEY SHOULD BE DECIDED BASED ON IT.

NOTE B005
PIPE SIZE WRITTEN IN THE DRAWING IS TYPICAL. IT SHOULD BE REVIEWED.

NOTE 2
VIBRATION MONITOR (REQUIRED BY END-USER) AND TEMPERATURE MONITOR (IF REQUIRED) FOR MOTOR ARE NOT SHOWN IN THIS P&ID. BHEL SHALL FINALIZE THE OPERATION PHILOSOPHY FOR WET BALL MILL AND REFLECT IT TO P&ID AND OTHER DRAWINGS SUCH AS INTERLOCK LOGIC DIAGRAM.

NOTE
THIS PID TO BE READ ALONG WITH VENDOR PID'S

NOTE: 1. Process Parameters
- Flow - m³/hr
- Pressure - Kg/cm² (Design Pressure)
- Temp - Deg C (Design Temp)

00 HTK 00 AM 001 MILL SEPARATOR TANK AGITATOR A	00 HTK 01 BB 001 MILL SEPARATOR TANK A	00 HTK 02 AP 001/002 MILL CIRCUIT PUMP A/B	00 HTK 00 AJ 001 WET LIMESTONE GRINDING MILL A	00 HTK 00 AT 001 MILL HYDRO CYCLONE A	00 HTK 01 AT 001 DISTRIBUTION BOX A
---	---	---	---	--	--

CUSTOMER NOS:G801			
CUSTOMER: TSGENCO.			
PROJECT: KTPS 1X800 MW FGD SYSTEM PACKAGE			
DEPT	NAME (BHEL)	DATE	
CODEDRN	KM.KABILASH	11.03.21	
M	P.RAJU	11.03.21	
APPD	PNR/ACR/RSB	11.03.21	
MITSUBISHI HITACHI POWER SYSTEMS, LTD. AIR QUALITY CONTROL SYSTEMS TECHNOLOGY DIVISION			
P & ID - LIMESTONE BALL MILL SYSTEM (TRAIN A)			
FILE NO	SH 01 of 03	SCALE : HTS	
BHEL DRG NO. 03-FW-734-00598			
FILE NO	REV NO		
B240-00511	02		



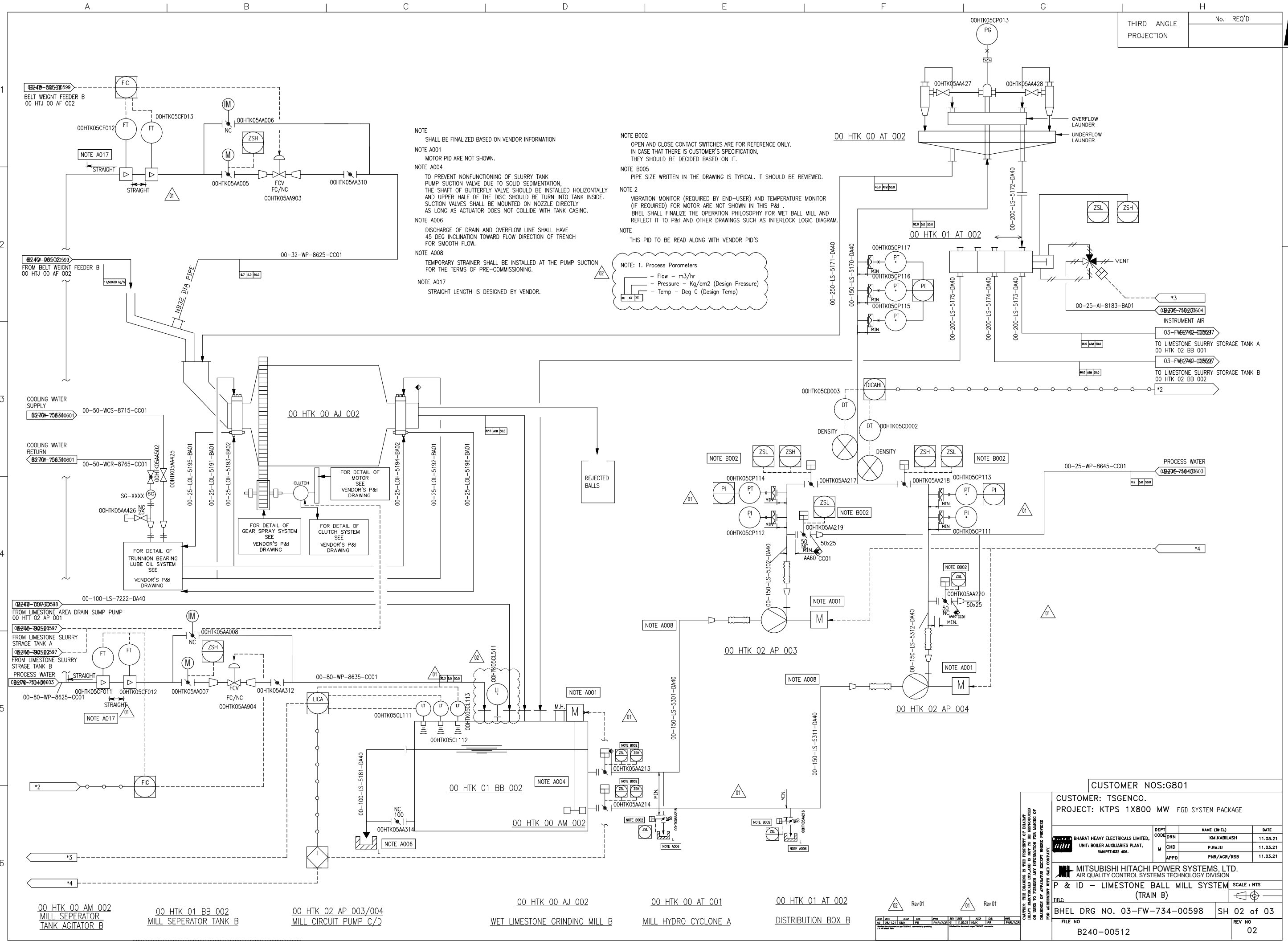

NOTE
SHALL BE FINALIZED BASED ON VENDOR INFORMATION

NOTE A001
MOTOR PID ARE NOT SHOWN.

NOTE A004
TO PREVENT NONFUNCTIONING OF SLURRY TANK PUMP SUCTION VALVE DUE TO SOLID SEDIMENTATION, THE SHAFT OF BUTTERFLY VALVE SHOULD BE INSTALLED HORIZONTALLY AND UPPER HALF OF THE DISC SHOULD BE TURN INTO TANK INSIDE. SUCTION VALVES SHALL BE MOUNTED ON NOZZLE DIRECTLY AS LONG AS ACTUATOR DOES NOT COLLIDE WITH TANK CASING.

NOTE A006
DISCHARGE OF DRAIN AND OVERFLOW LINE SHALL HAVE 45 DEG INCLINATION TOWARD FLOW DIRECTION OF TRENCH FOR SMOOTH FLOW.

NOTE A008
TEMPORARY STRAINER SHALL BE INSTALLED AT THE PUMP SUCTION FOR THE TERMS OF PRE-COMMISSIONING.

NOTE A017
STRAIGHT LENGTH IS DESIGNED BY VENDOR.

NOTE B002
OPEN AND CLOSE CONTACT SWITCHES ARE FOR REFERENCE ONLY. IN CASE THAT THERE IS CUSTOMER'S SPECIFICATION, THEY SHOULD BE DECIDED BASED ON IT.

NOTE B005
PIPE SIZE WRITTEN IN THE DRAWING IS TYPICAL. IT SHOULD BE REVIEWED.

NOTE 2
VIBRATION MONITOR (REQUIRED BY END-USER) AND TEMPERATURE MONITOR (IF REQUIRED) FOR MOTOR ARE NOT SHOWN IN THIS P&I. BHEL SHALL FINALIZE THE OPERATION PHILOSOPHY FOR WET BALL MILL AND REFLECT IT TO P&I AND OTHER DRAWINGS SUCH AS INTERLOCK LOGIC DIAGRAM.

NOTE
THIS PID TO BE READ ALONG WITH VENDOR PID'S

NOTE: 1. Process Parameters

- Flow - m³/hr
- Pressure - Kg/cm² (Design Pressure)
- Temp - Deg C (Design Temp)

00 HTK 00 AM 002 MILL SEPARATOR TANK AGITATOR B	00 HTK 01 BB 002 MILL SEPARATOR TANK B	00 HTK 02 AP 003/004 MILL CIRCUIT PUMP C/D	00 HTK 00 AJ 002 WET LIMESTONE GRINDING MILL B	00 HTK 00 AT 001 MILL HYDRO CYCLONE A	00 HTK 01 AT 002 DISTRIBUTION BOX B	00 HTK 00 AT 002 DISTRIBUTION BOX B
---	---	---	---	--	--	--

CUSTOMER NOS:G801			
CUSTOMER: TSGENCO.			
PROJECT: KTPS 1X800 MW FGD SYSTEM PACKAGE			
DEPT	NAME (BHEL)	DATE	
CODEDRN	KM.KABILASH	11.03.21	
M	P.RAJU	11.03.21	
APPD	PNR/ACR/RSB	11.03.21	
MITSUBISHI HITACHI POWER SYSTEMS, LTD. AIR QUALITY CONTROL SYSTEMS TECHNOLOGY DIVISION			
P & ID - LIMESTONE BALL MILL SYSTEM (TRAIN B) SCALE: HTS			
BHEL DRG NO. 03-FW-734-00598		SH 02 of 03	
FILE NO	B240-00512	REV NO	02



Write up on Limestone grinding system

Purpose: This write up describes the equipment associated with Limestone pulverize and wet ball mill system and defines the associated control system.

Equipment List:

S. No.	Description	Item No.	Qty
1.	Wet Ball Mill	00 HTK 00 AJ 001/002	1W+1S
2.	Mill Hydro cyclone	00 HTK 00 AT 001/002	1W+1S
3.	Mill separator tank	00 HTK 01 BB 001/002	1W+1S
4.	Mill separator tank agitator	00 HTK 00 AM 001/002	1W+1S
5.	Mill circuit Pump	00 HTK 02 AP 001/004	2X(1W+1S)

Operation Write Up:

Limestone is sent to Wet Ball Mill through Limestone Intermediate Silo Shut-off Gate, Dosing Bin, Belt Weigh Feeder, Belt Feeder and Crusher. The Limestone Grinding System consists of Wet Ball Mills, Wet Ball Mill oil units, Wet Mill Receiver Tanks, Limestone Suspension Pumps, Mill Hydro cyclones and Distribution boxes.

The Belt Weigh Feeder is installed at Dosing Bin bottom which feeds limestone to the Wet Ball Mill. The limestone feed rate is weighed by the Belt Weigh Feeder. The Wet Ball Mills are the wet horizontal type. Process water is supplied to Wet Ball Mill inlet and Mill separator Tank. Slurry from the Wet Ball Mill flows by gravity to Mill separator Tank and then is pumped up to Mill Hydro cyclone to be classified.

The Mill Hydro cyclone underflow, which contains the oversized Limestone, is recirculated to Wet Ball Mill inlet directly, while the overflow is discharged to Limestone Slurry Storage Tank via Distribution Box as a product of Limestone Grinding System. The limestone slurry is pumped from the Limestone Slurry Storage Tank through a ring line and fed to the absorber tank.

Control:**1. Limestone Grinding System Control**

Limestone Feed rate is kept constant by belt weigh feeder. The limestone which is conveyed from the Dosing Bin by using the belt weigh feeder and the process water are supplied into a limestone ball mill system. The flow rate of process water to wet limestone grinding mill is controlled by Limestone feeding amount at belt weigh feeder. The flow rate of process water to wet mill receiver tank is controlled by density signal from mill hydrocyclone feed slurry.

The slurry in wet mill separator tank is fed up to the mill hydro cyclone and separated into small particle slurry and large particle slurry. The underflow slurry (large particle size limestone) is returned to wet ball mill inlet. The overflow slurry of mill hydro cyclone (small particle size limestone) is sent to the limestone slurry storage tank. The mill separator tank level is controlled by the position of the limestone slurry distribution box. If the wet mill receiver tank level is control low, the overflow slurry of mill hydro cyclone is returned to the Mill separator Tank by recirculation position of the limestone slurry distribution box. And if Mill separator Tank level is control high, the overflow slurry of mill hydro cyclone is send to the limestone slurry storage tank discharge position of the limestone slurry distribution box.

Fig.- Limestone Grinding System Control

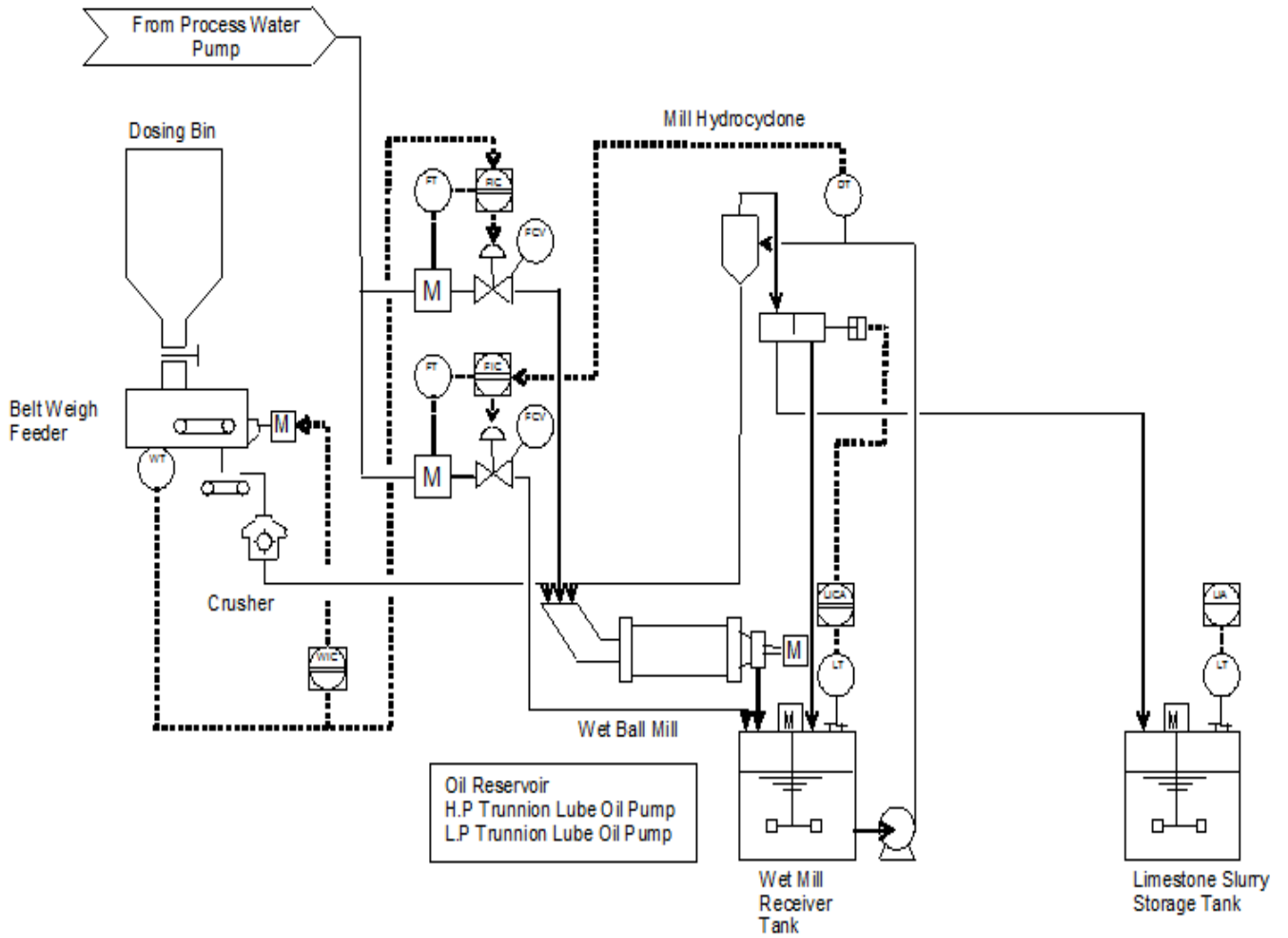

Instruments List (Sheet 1)

SI.No	KKS Code	Description of instrument	Quantity
01	00HTK05CF001/004	Flow Transmitter	04 Nos
02	00HTK05CL001/003	Level Transmitter	03 Nos
03	00HTK05CL501	Level Indicator	01 Nos
04	00HTK05CP001/002	Pressure Indicator	02 Nos
05	00HTK05CP003/007	Pressure Transmitters	05 Nos
06	00HTK05CD001/002	Density Meter	02 Nos

Instruments List (Sheet 2)

SI.No	KKS Code	Description of instrument	Quantity
01	00HTK05CF011/014	Flow Transmitter	04 Nos
02	00HTK05CL011/013	Level Transmitter	03 Nos
03	00HTK05CL511	Level Indicator	01 Nos
04	00HTK05CP111 /112	Pressure Indicator	02 Nos
05	00HTK05CP113/117	Pressure Transmitters	05 Nos
06	00HTK05CD003/004	Density Meter	02 Nos

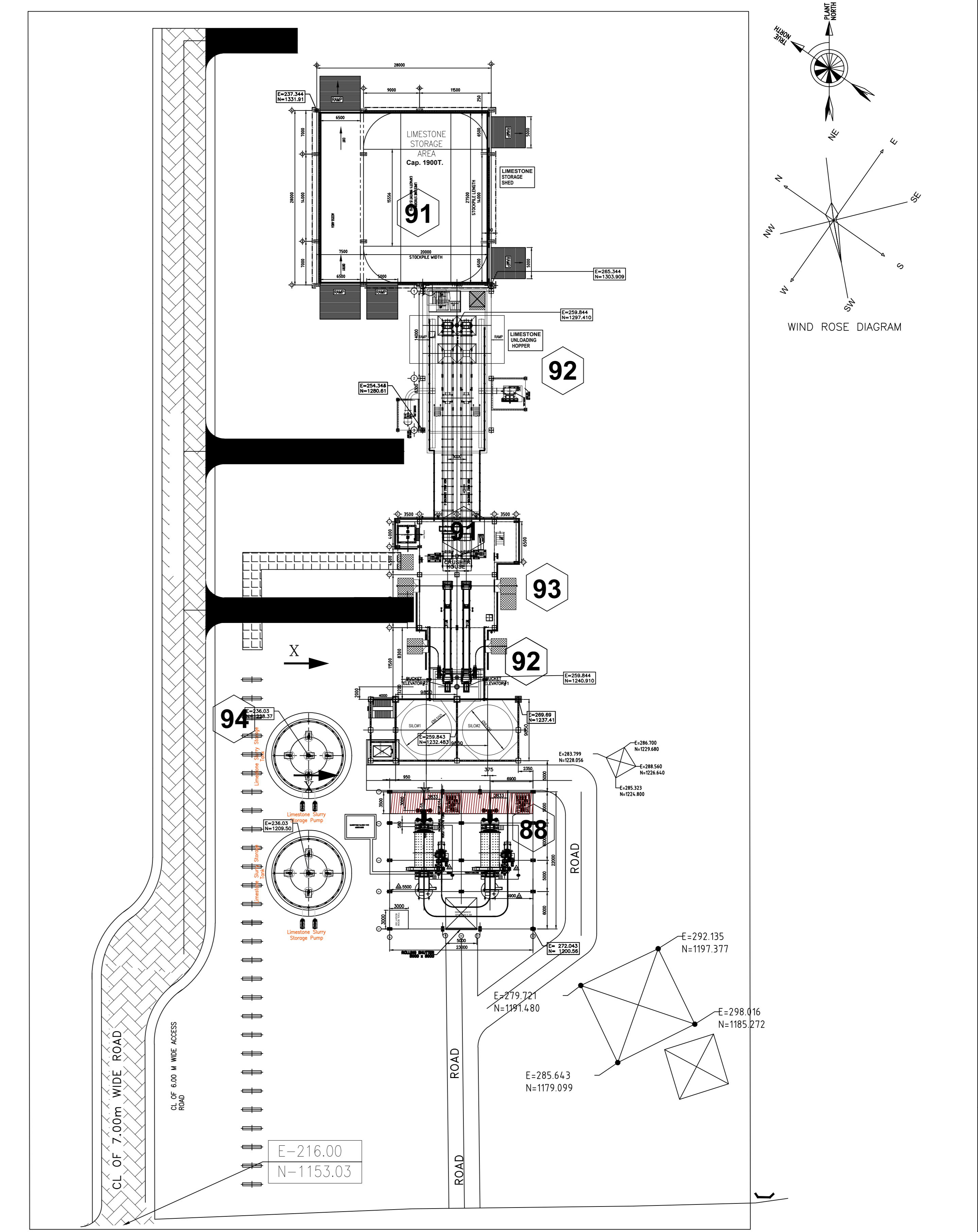
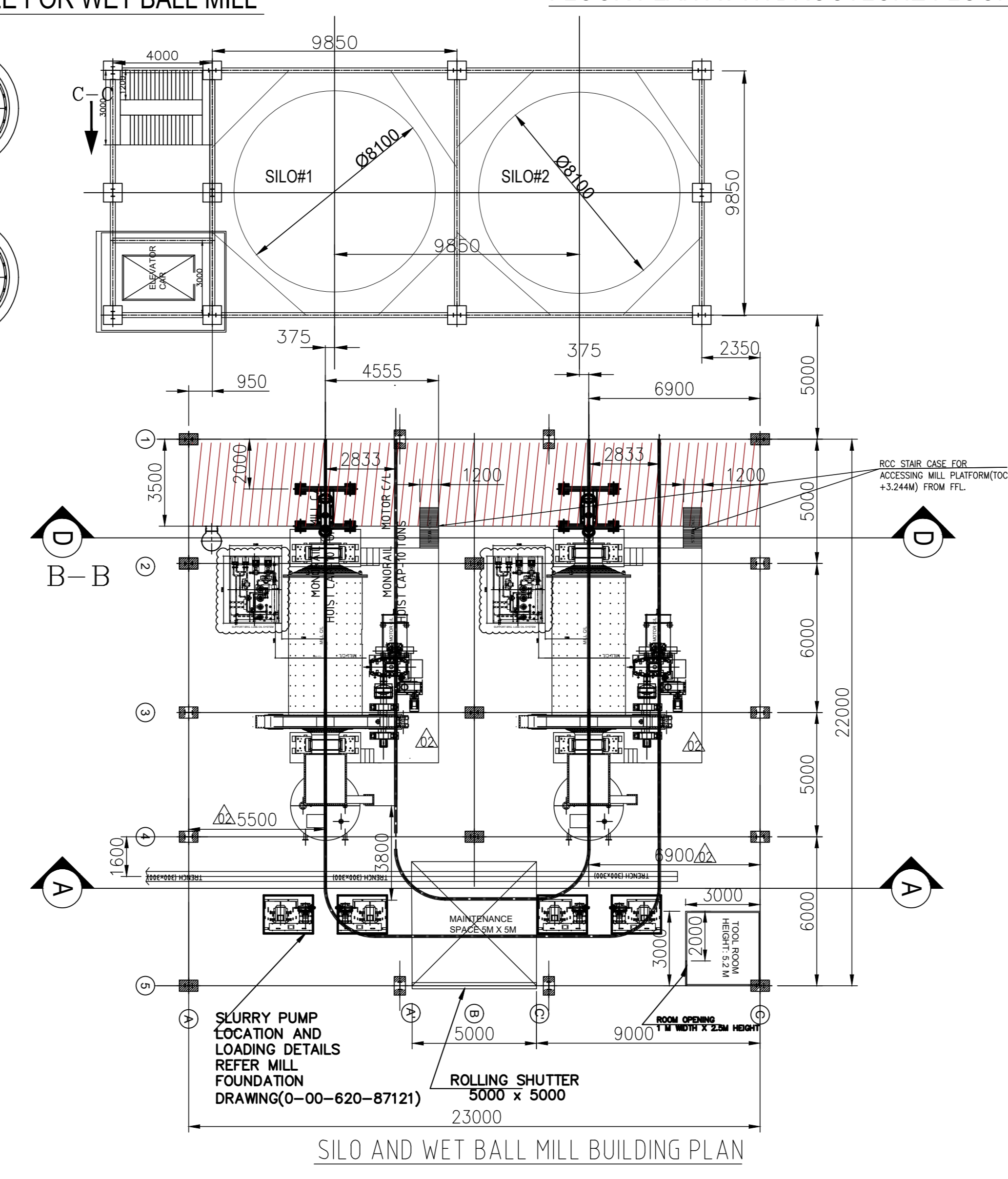
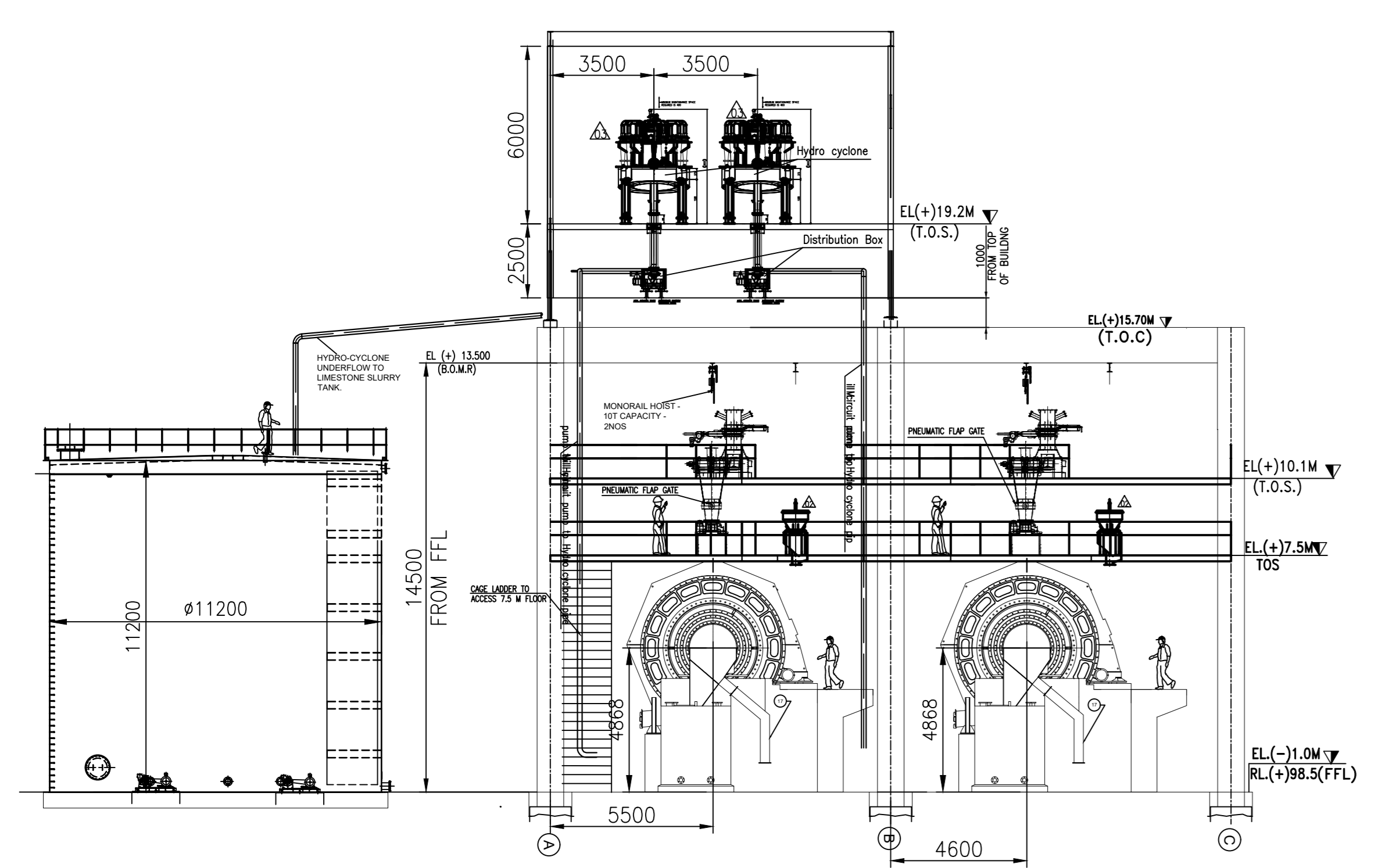
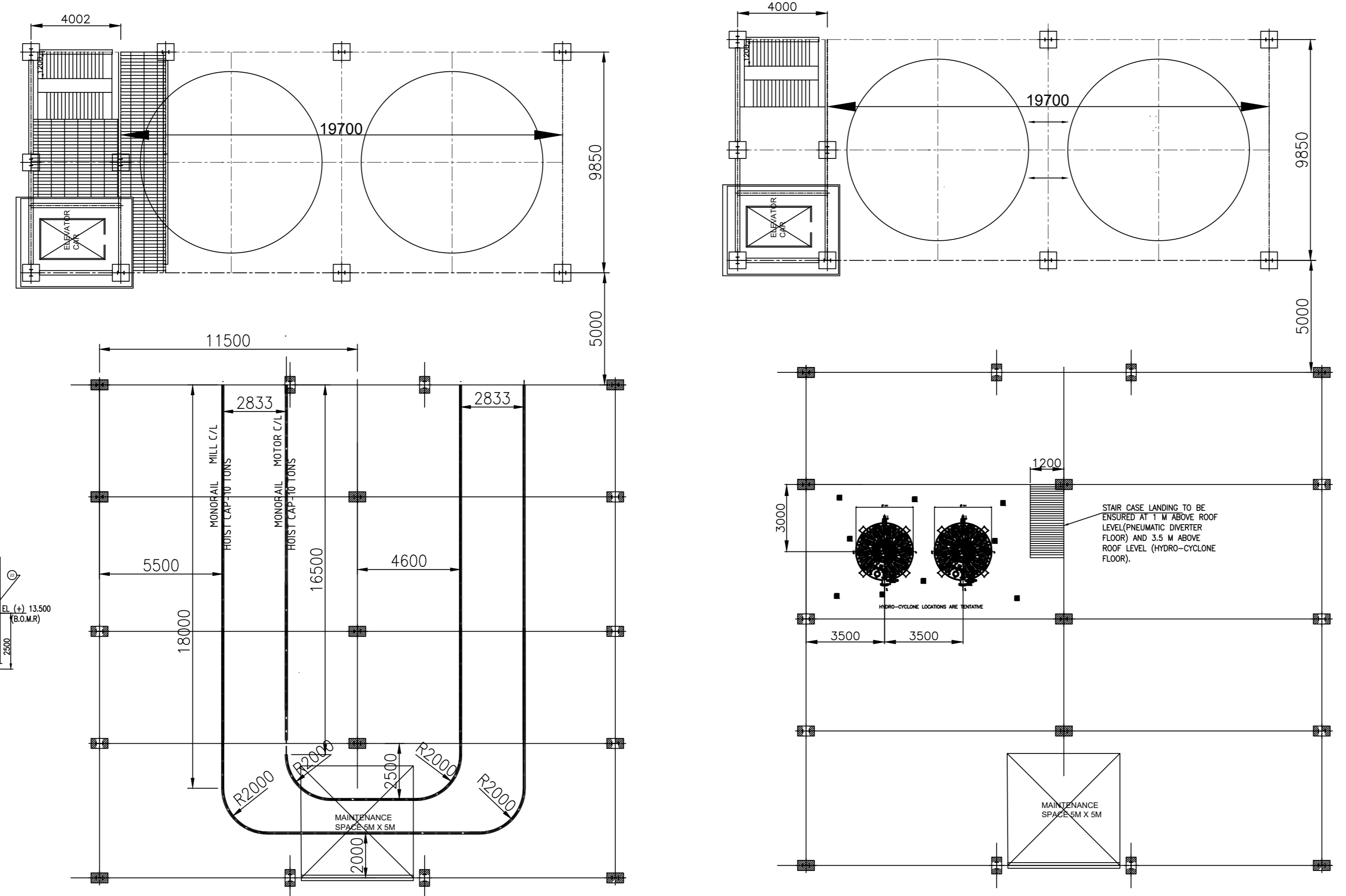
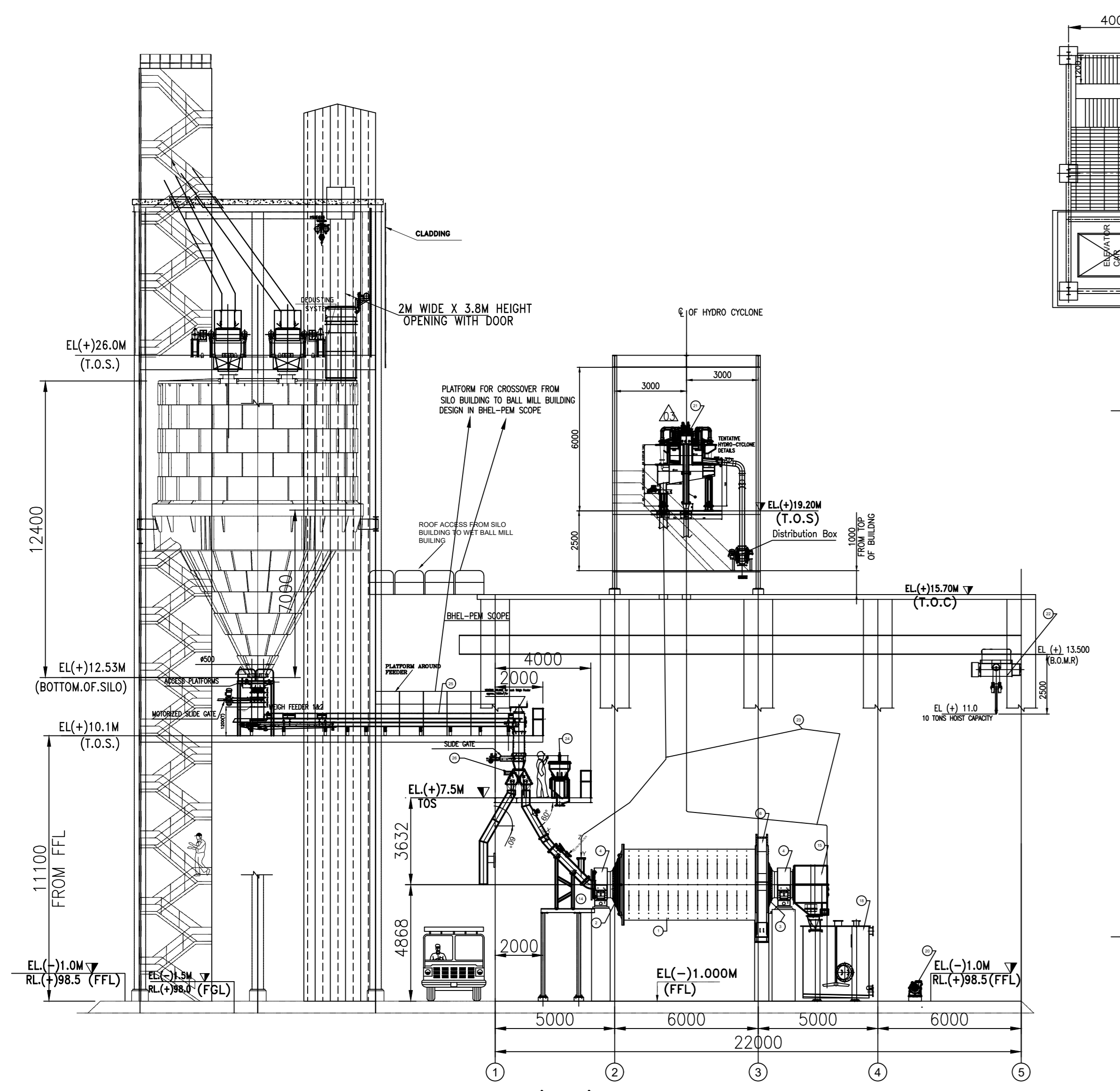

NOTES:-

- ALL DIMENSIONS ARE IN MM & LEVELS ARE IN METERS.
- THE FINISHED FLOOR LEVEL (FFL) OF POWER HOUSE BUILDING GROUND FLOOR IS EL(+0.00 WHICH CORRESPONDS TO 0.5M (RL 99.5M) ABOVE FINISHED GROUND LEVEL FGL.
- FLOOR OPENINGS, PIPE CROSSINGS SHALL BE CONFIRMED DURING DETAIL ENGINEERING.
- INSPECTION DOOR SHALL BE LEAK PROOF.
- GRAVIMETRIC FEEDER DETAILS SHOWN IS TENTATIVE ONLY AND SHALL BE FINALIZED AFTER GETTING SUPPLIER DATA
- BUILDING HAS BEEN DESIGNED CONSIDERING ALL EQUIPMENTS, GRAVIMETRIC FEEDERS, BELT FEEDERS, CONVEYORS WORKING SIMULTANEOUSLY UNDER FULL LOAD.
- ALL LEVELS AND GRIDS ARE INDICATED IN METRES. ALL DIMENSIONS ARE IN MM UNLESS OTHERWISE SPECIFICALLY MENTIONED
- BUILDING SHALL BE DESIGNED CONSIDERING ALL CHUTES IN CLOGGED CONDITION.
- ALL CIVIL & STRUCTURAL WORKS IN THIS AREA ARE IN SCOPE OF BHEL-PEM/ PE&SD.
- THIS DRAWING TO BE READ IN CONJUNCTION WITH ISG DRAWING GA OF LIMESTONE BUCKET ELEVATOR BE-1 /2 (DRAWING No.: IS-3-GA-720-101-M009).
- REMOVAL LADDERS SHALL BE PROVIDED FOR ACCESSING FEEDER OUTLET GATE.

REFERENCE DRAWING:-

- F&D PLOT PLAN REF. DWG. PY-1Q-0-M12-1255-01 AND PLOT PLAN REF. DWG. PE-DG-410-100-M001
- DRAWING TO BE READ IN CONJUNCTION WITH G.A. OF WET BALL MILL REFER DWG. 0-00-620-87120 AND FOUNDATION 0-00-620-87121
- G.A. AND DATA SHEET OF ELEVATOR (PASSENGER CUM GOODS ELEVATOR) OF DAY SILO STRUCTURE REFER DWG. 0370-109-PVM-B-001
- DRAWING TO BE READ IN CONJUNCTION WITH BHEL-ISG MECHANICAL GA DRAWING OF LIMESTONE BUCKET ELEVATOR BE-1/2 REF. DWG. IS-3-GA-720-101-M009
- REV. BELT FEEDER DRG IS-3-GA-720-101-M008
- SITE LEVELLING AND GRADING (PE-DG-439-603-C005)
- MILL GENERAL ARRANGMENT DRAWING HY-WBM-KTFS-GA-0.

BILL OF MATERIAL - WET BALL MILLING SYSTEM

ITEM No.	DESCRIPTION	QUANTITY	UNIT	REMARKS
01	BALL MILL SHELL ASSY	01	NO.	MANUFACTURE TO ISG
02	CHEEK WITH TRANNNON, NDE	01	NO.	MANUFACTURE TO ISG
03	CHEEK WITH TRANNNON, DE	01	NO.	MANUFACTURE TO ISG
04	SUPPORT BEARING ASSY	02	NO.	MANUFACTURE TO ISG
05	BALL MILL LINERS	25 SET	NO.	MANUFACTURE TO ISG
06	GRITH GEAR & GRITH GEAR HSG ASSY	01	NO.	MANUFACTURE TO ISG
07	FINNIN	01	NO.	MANUFACTURE TO ISG
08	FINNIN BEARING BODY WITH COVER-ALONG	01	NO.	MANUFACTURE TO ISG
09	FINNIN BEARING BODY WITH COVER-THRUST	01	NO.	MANUFACTURE TO ISG
10	COUPLING BETWEEN MAIN REDUCER & DRIVE ASSY	01	NO.	MANUFACTURE TO ISG
11	MAIN REDUCER (GEAR BOX)	01	NO.	MANUFACTURE TO ISG
12	MAIN MOTOR	01	NO.	MANUFACTURE TO ISG
13	FINNIN REDUCER ASSEMBLY	01	NO.	MANUFACTURE TO ISG
14	INLET HOOD ASSY	01	NO.	MANUFACTURE TO ISG
15	TROMMEL SCREEN	01	NO.	MANUFACTURE TO ISG
16	DISCHARGE HOOD ASSY	01	NO.	MANUFACTURE TO ISG
17	RELIEF CHUTE	01	NO.	MANUFACTURE TO ISG
18	SLURRY TANK WITH AGITATOR	01	NO.	MANUFACTURE TO ISG
19	COUPLING BETWEEN MAIN MOTOR & MAIN REDUCER	01	NO.	MANUFACTURE TO ISG
20	SLURRY PUMP	02	NO.	MANUFACTURE TO ISG
21	MEL HYDRO-CYCLONE WITH DISTRIBUTION BOX	01	NO.	MANUFACTURE TO ISG
22	ELECTRIC HOIST	01	NO.	MANUFACTURE TO ISG
23	SLURRY PUMP	01	NO.	MANUFACTURE TO ISG
24	BALL CHARGE HOPPER	01	NO.	MANUFACTURE TO ISG
25	LIMESTONE FEEDER	01	NO.	MANUFACTURE TO ISG
26	PNEUMATIC DIVERTOR	01	NO.	MANUFACTURE TO ISG

LEGEND :-

F.F.L = FINISHED FLOOR LEVEL
 F.G.L = FINISHED GROUND LEVEL
 T.O.F.F = TOP OF FINISHED FLOOR LVL
 T.O.S = TOP OF STEEL
 T.O.C.C = TOP OF CHANE GIBBER
 T.O.B.C. = TOP OF REINFORCED CEMENT CONCRETE
 B.O.M.R = BOTTOM OF MONORAIL
 M.H = MANUAL HOIST
 E.H = ELECTRIC HOIST
 T.P = TRANSFER POINT
 L.C = LIMESTONE BELT CONVEYOR
 C.A.S = CHUTE JAMMING SWITCH
 L.S = LIMESTONE STORAGE SILO
 B.O.S = BOTTOM OF SILO

REVISIONS

REV.	DATE	ALTD	CHD	APPRO	REV.	DATE	ALTD	CHD	APPRO
01	04.07.22	AMAN	KRKR		02	23.09.22	AMAN	KRKR	
03	06.05.22	AMAN	KRKR		04				

NO CHANGE IN DRAWING DRAWING REVISED TO MATCH PEDM REVISION.

MODIFIED INLINE WITH CUSTOMER VICE COMMENTS

TELANGANA STATE POWER GENERATION CORPORATION LTD
 TELANGANA, INDIA
 1x800 MW KOTHAGUDAM TPS STAGE-VII UNIT#12, PALONCHA
DEVELOPMENT CONSULTANTS PVT. LTD.
 CONSULTING ENGINEERS
 KOLKATA MUMBAI CHENNAI NEW DELHI
BHARAT HEAVY ELECTRICALS LTD
 HYDERABAD

WET BALL MILL BUILDING GA DRAWING.

DEPT. SCALE DRAWING NO. 0-FW-000-01085
 SHEET 1 OF 1 REV. 04

COPY RIGHT AND CONFIDENTIAL. This information on this document is the property of BHARAT HEAVY ELECTRICALS LIMITED. It must not be used directly or indirectly in any way detrimental to the interest of the company.

ITEM No:	DESCRIPTION	QTY/MILL	WT (KGS)	MOC
01	BALL MILL SHELL ASSLY (Inner Diameter X length: ϕ 2.9 m X 5.8 m)	01	18275	IS 2062
02	CHEEK WITH TRUNNION_NON DRIVE END	01	6590	ASTM A216,GR:WCA
03	CHEEK WITH TRUNNION_DRIVE END	01	6600	ASTM A216,GR:WCA
04	MILL SUPPORT BEARING ASSLY	02	2300	IS 2062 with bronze shell
05	INLET HOOD ASSLY	01	1200	IS 2062 +rubber lining
06	GIRTH GEAR & GIRTH GEAR HSG ASSY	01	8500	42CrMo4 + IS 2062
07	DRIVE SHAFT ASSEMBLY WITH PINION	01	1230	40CrMo3 + 34CrNiMo4
08	PINION BEARING HOUSING-NDE	01	845	IS 210-2009 Gr FG 300
09	PINION BEARING HOUSING-DE	01	845	IS 210-2009 Gr FG 300
10	COUPLING BETWEEN MAIN REDUCER & DRIVE ASSY	01	410	C40/BS EN 10277-2
11	MAIN REDUCER (GEAR BOX)	01	5450	---
12	MAIN MOTOR	01	6850	---
13	INCHING REDUCER ASSEMBLY WITH INCHING MOTOR	01	1200	---
14	DISCHARGE HOOD ASSLY	01	950	IS 2062 +rubber lining
15	REJECT CHUTE	01	150	IS 2062 +rubber lining
16	SLURRY TANK	01	2230	IS 2062 +rubber lining
17	COUPLING BETWEEN MAIN MOTOR & MAIN REDUCER	01	300	C40/BS EN 10277-2
18	MILL LINERS	01 SET	8000	Rubber
19	TROMMEL SCREEN	01	750	IS 2062 +rubber lining
20	LUBRICATION UNIT (for SUPPORT BEARING ASSEMBLY)	01	800	---
21	LUBRICATION UNIT (for MAIN REDUCER)	01	870	---

WET BALL MILL DETAILS

- MILL CAPACITY : 17.15 TPH
- NO: OF MILLS : 1 (WORKING) +1 (STANDBY)
- MOTOR RATING : 650 KW
- INCHING MOTOR RATING : 15 KW
- RPM OF MAIN MOTOR : 985 RPM
- RPM OF WET BALL MILL : 18.95 RPM
- DIRECTION OF ROTATION : ANTICLOCKWISE (VIEWED FROM DRIVE END-GIRTH GEAR SIDE)

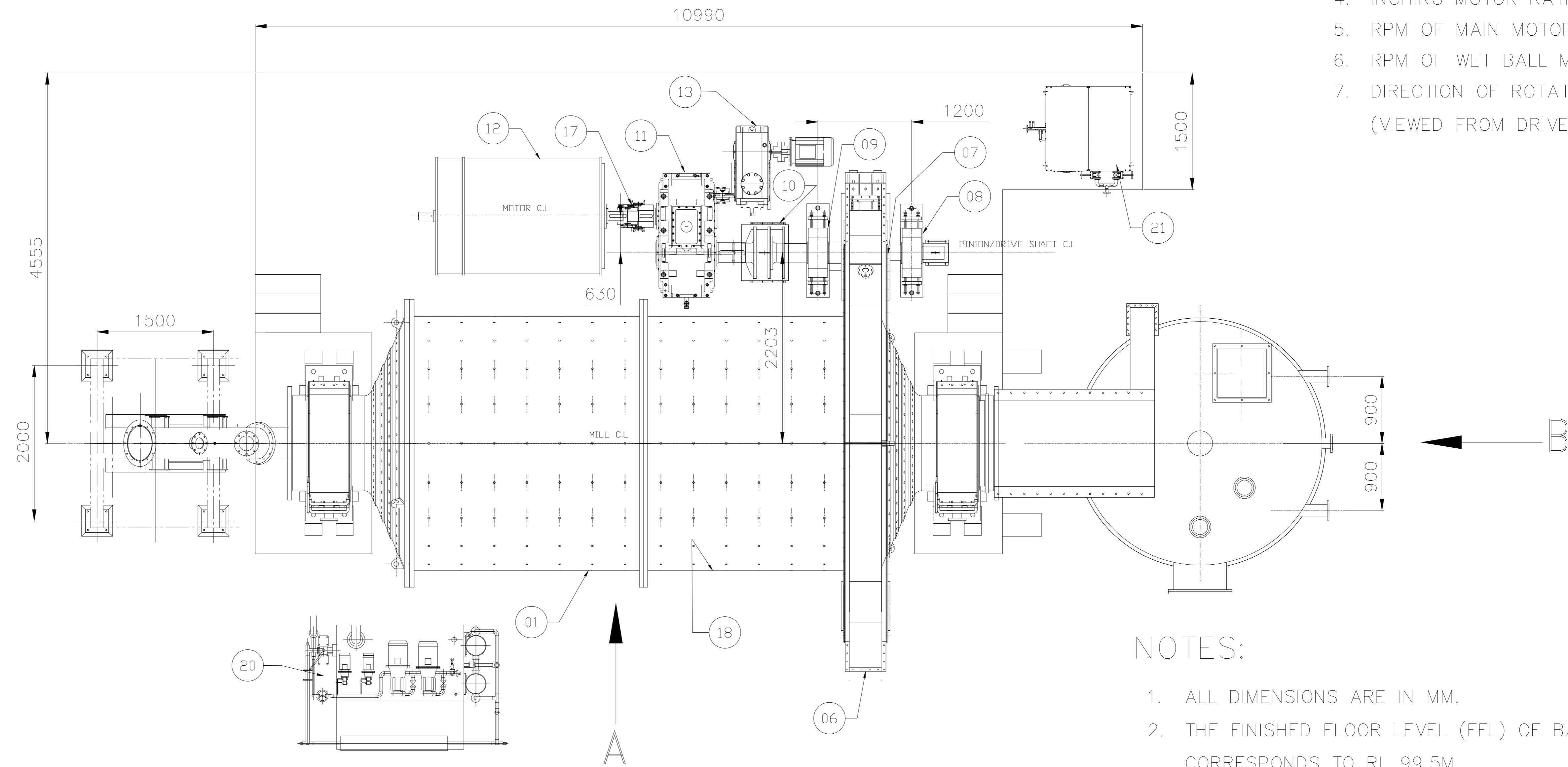

NOTES:

- ALL DIMENSIONS ARE IN MM.
- THE FINISHED FLOOR LEVEL (FFL) OF BALL MILL BUILDING CORRESPONDS TO RL 99.5M.
- THE MAXIMUM WEIGHT OF SINGLE COMPONENT TO BE HANDLED DURING MAINTENANCE IS MOTOR AND WEIGHT IS 6850 KGS.

REF. DRGS :

- FOUNDATION PLAN OF WET BALL MILL : HY-WBM-KTPS-FDN-00.
- WET BALL MILL BUILDING GA DRAWING : 0-FW-000-01085.
- DATA SHEET OF WET BALL MILL : HY-WBM-KTPS-DS-0-Rev 04.

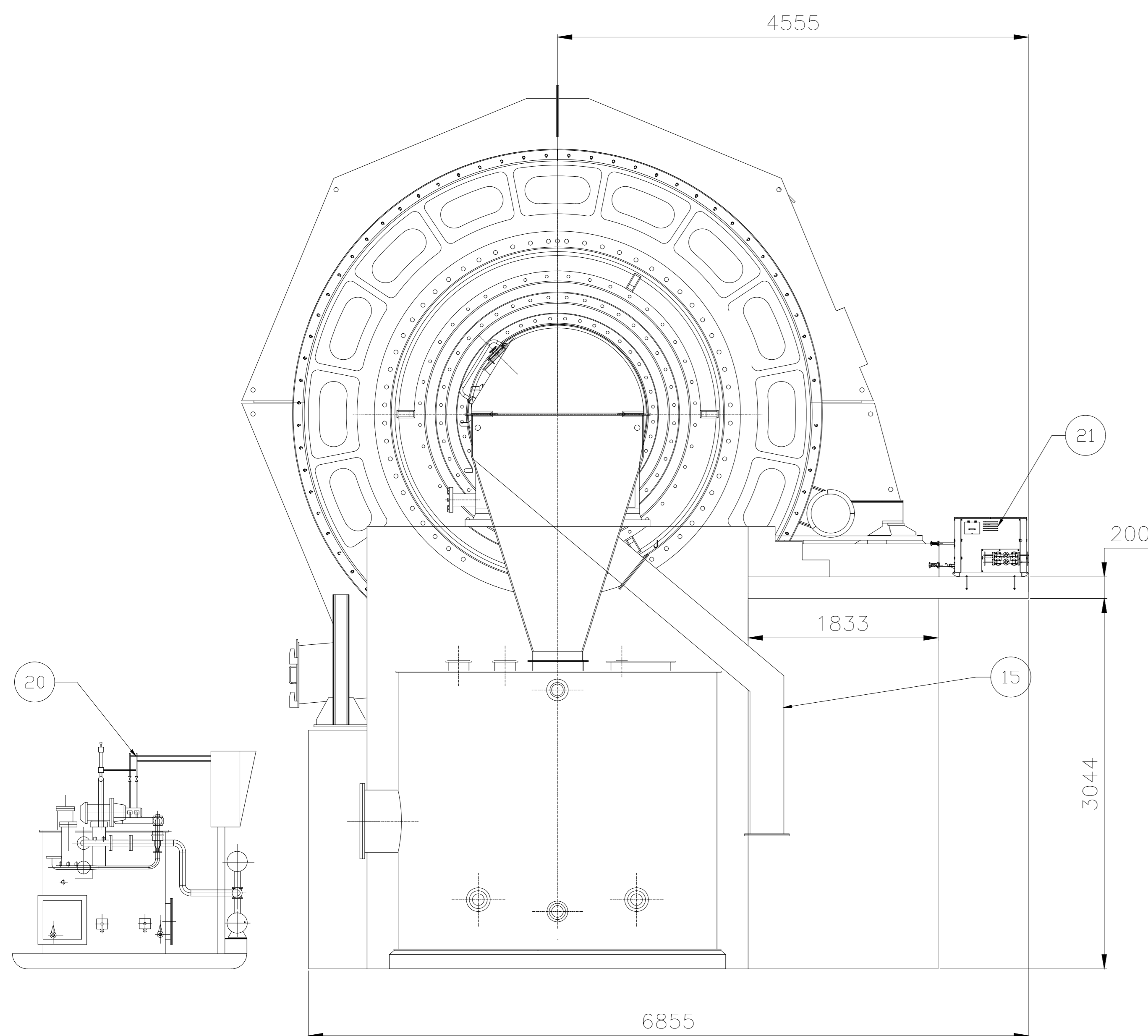

VIEW: B

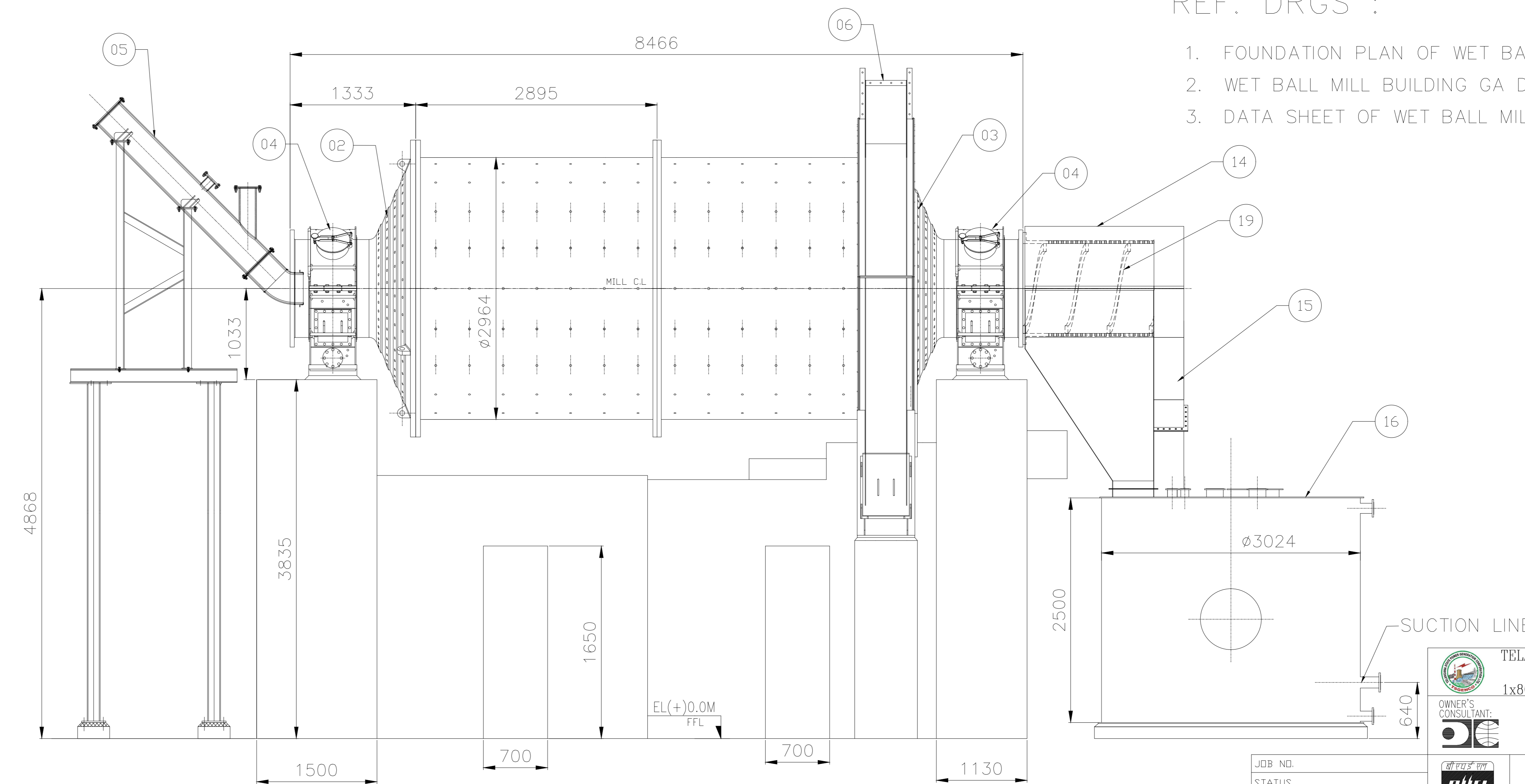

VIEW: A

JOB NO.	
STATUS	
DISTRIBUTION	

REV.	DATE	ALD	CHD	APPD	REV.	DATE	ALD	CHD	APPD
02	26.08.22	K PAVAN	AMAN	khbk	01	28.04.22	K PAVAN	AMAN	khbk

TELANGANA STATE POWER GENERATION CORPORATION LTD
 TELANGANA, INDIA
 1x800 MW KOTHAGUDAM TPS STAGE-VII UNIT#12, PALONCHA
DEVELOPMENT CONSULTANTS PVT. LTD.
 CONSULTING ENGINEERS
 KOLKATA MUMBAI CHENNAI NEW DELHI
BHARAT HEAVY ELECTRICALS LTD
 HYDERABAD

DEPT	SCALE	DRAWING NO.
HY	1:1	HY-WBM-KTPS-GA-0
SHEET	1 OF	REV.

COPY RIGHT AND CONFIDENTIAL. The information on this document is the property of Bharat Heavy Electricals Limited. It must not be used directly or indirectly in any way without the prior written consent of the company.



DOCUMENT TITLE:
DESIGN MEMORANDUM FOR FGD
1 X 800 MW KOTHAGUDEM TPS

BHEL DOCUMENT NO.: 04-FW-000-00525
 DEPARTMENT: FGD ENGINEERING GROUP
 REV. NO. 04 | DATE: 23.01.2021
 Page: 18 of 26

3.3. LIMESTONE CHARACTERISTICS CONSIDERED FOR FGD DESIGN:

CHEMICAL ANALYSIS (% BY MASS)			
Sl. No	Description	unit	Values
1.	CaO	%	>= 51.0
2.	MgO	%	0.9 – 3.8
3.	Fe ₂ O ₃	%	0.45 - 1.0
4.	Al ₂ O ₃	%	1.19 – 2.1
5.	Si ₂ O ₃	%	2.1 – 4.5
6.	Mn ₂ O ₃	%	< 0.12
7.	P ₂ O ₅	%	Traces
8.	Cl ₂	%	< 0.015
9.	Na ₂ O	%	< 0.16
10.	K ₂ O	%	< 0.01
11.	TiO ₂	%	< 0.02
12.	Total Sulphur	%	< 0.1
13.	LOI		38 – 41.3
PHYSICAL PROPERTIES			
14.	Bond Index	KWh/Metric ton	14.33
15.	Granule size		Medium (250 mm)
16.	Bulk density		
	a. Volume	Kg/m ³	1400
	b. Torque and drive calculation	Kg/m ³	1700
	c. Structural load calculation	Kg/m ³	2200

Note: BHEL considered CaO % in limestone as 47.0 % for FGD design point and 50 % for FGD guarantee point (CaCO₃ of 89 %), BHEL confirms that FGD systems for Kothagudem will work satisfactorily in terms of meeting outlet emission of SO₂ even if CaO % of Limestone as 45.9%.



3.4. WATER PROPERTIES CONSIDERED FOR FGD DESIGN:

Sl. No	Constituents	as	mg per litre
1.	Calcium	CaCO ₃	141.5
2.	Magnesium	CaCO ₃	45.0
3.	Sodium & Potassium	CaCO ₃	25.0
4.	Bi-Carbonates	CaCO ₃	117.5
5.	Chloride	CaCO ₃	27
6.	Sulphate	CaCO ₃	67
7.	Carbonate	CaCO ₃	0
8.	Silica	SiO ₂	10
9.	Iron	Fe	0.5
10.	pH value	-	7.8
11.	Turbidity	NTU	<15
12.	TDS		<500

ANNEXURE-6

Customer: TSGENCO
Project: KOTHAGUDEM

Material Feed	17	t/h
Spec. Gravity	2700	kg/m3
Moisture	0	%

Limestone: 0-25 mm.

Grinding water		
Material Feed	9.7	t/h
Spec. Gravity	1000	kg/m3
Flow	9.7	m3/hr.

Dilution water		
Material Feed	30.3	t/h
Spec. Gravity	1000	kg/m3
Flow	30.3	m3/hr.

Cyclone underflow		
Slurry	84.1	t/h
Solid	60.5	t/h
Liquid	23.5	t/h
Slurry conc.	72.0	%
Density	1829	kg/m3
Flow	46	m3/hr.

Cyclone Overflow		
Slurry	57.2	t/h
Solid	17.2	t/h
Liquid	40.0	t/h
Slurry conc.	30.0	%
Density	1233	kg/m3
Flow	46	m3/hr.

Cyclone Feed		
Slurry	141.3	t/h
Solid	77.7	t/h
Liquid	63.6	t/h
Slurry conc.	55.0	%
Density	1530	kg/m3
Flow	92	m3/hr.

Mill Discharge		
Slurry	111.0	t/h
Solid	77.7	t/h
Liquid	33.3	t/h
Slurry conc.	70.0	%
Density	1788	kg/m3
Flow	62	m3/hr.

CL = 350%

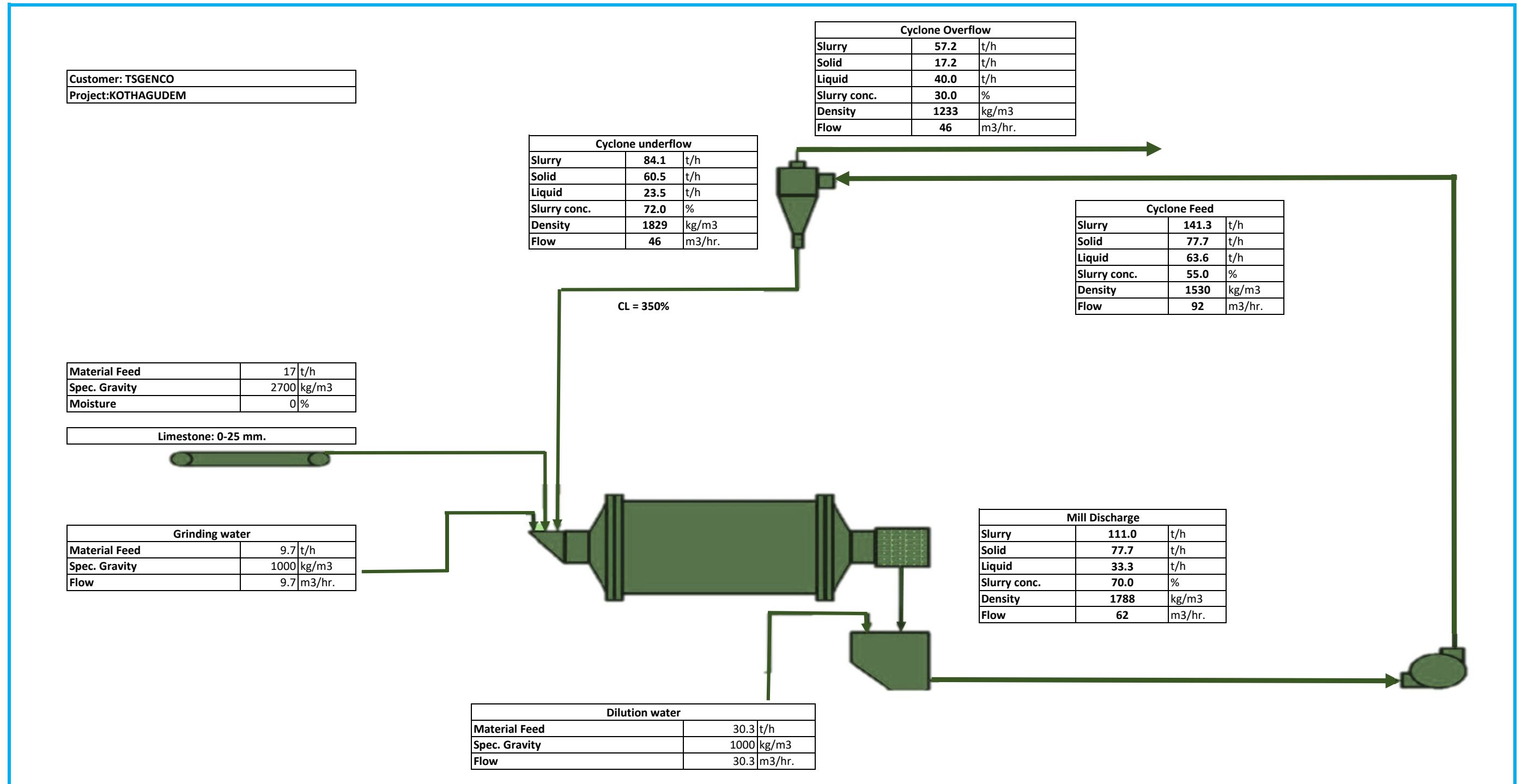

TECHNICAL REQUIREMENTS OF MEASURING INSTRUMENTS

a) SPECIFICATION FOR ELECTRONIC TRANSMITTER FOR PRESSURE, DIFF PRESS AND DP BASED FLOW / LEVEL MEASUREMENTS

Sl. No.	Features	Essential/Minimum Requirements
1.	Type of Transmitter	Microprocessor based 2 wire type (loop powered), Hart protocol compatible.
2.	Output signal	4-20 mA DC (Analog) along with superimposed digital signal based on HART protocol
3.	Accuracy	<p>± 0.060 % of calibrated range (minimum) for calibrated range greater than 400 mmwc.</p> <p>+0.065% of calibrated range (minimum) for calibrated range greater than 250 kg/cm².</p> <p>± 0.10 % of calibrated range (minimum) for calibrated range less than 400 mmwc</p>
4.	Turn down (minimum)	<p>50:1 for greater than or equal to span of 400mmwcl.</p> <p>20:1 for span below 400mmwcl.</p> <p>10:1 for span greater than 250 kg/cm²</p>
5.	Stability	<p>0.25 % of calibrated range for 10 years for calibrated range greater than equal to 400 mmwc on standard conditions of manufacturer.</p> <p>0.2 % of calibrated range for 1 years for calibrated range less than 400 mmwc on standard conditions of manufacturer.</p> <p>0.15% of calibrated range for 5 years for static pressure greater than 250 kg/cm².</p>
<i>(Above mentioned (3, 4, 5) parameters/features of offered models shall be strictly as defined in standard published catalogue of the manufacturer only).</i>		
6.	Zero and span drift	+/- 0.015 per deg C at max span +/-0.11% per deg C at min. Span
7.	Power Supply	24V DC \pm 10%.
8.	Load impedance	500 ohm (minimum)
9.	Housing	Weather proof as per IP-67, metallic housing with durable corrosion resistant coating
10.	Over Pressure	150% of max. Operating pressure
11.	Electrical Connection	Plug and socket type except in hazardous area
12.	Process connection	1/2 inch NPT (F)
13.	Span and Zero	Continuous, tamper proof, Remote as well as manual adjustability from instrument with zero suppression and elevation facility.

14.	Accessories	Diaphragm seal, pulsation dampeners, syphon etc. as required by service and operating condition.
15.	Diagnostics and Display	Self-Indicating feature and digital display
16.	Accessories	2 valve manifold for absolute & Gauge pressure transmitters, 3-valve manifold for Differential Pressure and 5 valve manifold for Level /Flow applications. The valve manifold shall be non-integral type (except Fuel Oil area). -For hazardous area, enclosure as described in NEC article 500 -2 inch pipe for mounting with Enclosure /Rack/Canopy
17.	Certification	SIL 2 or Better
18.	Adjustment/calibration /maintenance	From hand held HART calibrator

Notes:

LVDT type is not acceptable.

For primary air/ secondary air/flue gas applications, DP type transmitters shall be provided for pressure measurement below range of 2000 mmwc.

Where the process fluids are corrosive, viscous, solid bearing or slurry type, diaphragm seals shall be provided. Parts below the diaphragm shall be removable for cleaning. The entire volume above the diaphragm shall be completely filled with an inert liquid suitable for the application.

b) SPECIFICATION FOR GUIDED WAVE RADAR TYPE LEVEL TRANSMITTER

Type	Microprocessor based 2 wire type (loop powered), HART protocol compatible Guided wave radar transmitter.
Principle	TDR (Time domain reflectometry)
Probe Type & Material	(i) Coaxial probe of SS316/316L. If required, probe shall be suitable for overfill prevention. (ii) Rod probe, cable probe of SS316/SS316L can be used for applications wherever coaxial probe is not suitable.
Output signal	4-20 mA DC along with superimposed digital signal (based on HART protocol), suitable for over fill prevention.
Accuracy	+/- 0.5% of calibrated span or minimum 5mm.
Power supply	24 VDC +/- 10%.
Housing	Weather proof as per IP-65, metallic housing with durable corrosion resistance coating.
Adjustment/ calibration	Using hand held HART calibrator/ centralized PC based system (as applicable).
Zero & span adjustment	Continuous, temper proof, remote as well as manual adjustability from instrument. It should be possible to calibrate the instrument without any level in the tank/sump etc.
Display	Integral digital display.
Load Impedance	500 ohms (minimum).
Electromagnetic compatibility	Shall meet EN 61326-1 (1997) and AmdtA1, class A equipment/EN 50081-2 & EN 5008 1-2 & EN 50082-2
Mounting	(i) External cage shall be provided where ever side mounting is required. External cage and other mounting accessories to be provided by the contractor. (ii) Where ever top mounting is required, all mounting accessories, stilling well (as required) etc., shall be provided by the contractor. (iii) All weather canopy shall be provided for protection from direct sunlight and direct rain for open locations.

Note: Four wire type transmitters can also be provided for applications where 2- wire transmitter has some technical limitations, subject to employer's approval during detailed engineering stage. However, in such cases isolated 4-20 mA DC (analog) output shall be provided. Power supply required for such transmitters shall be 240V AC / 24V DC.

c) SPECIFICATION FOR ULTRA SONIC TYPE LEVEL TRANSMITTER

Sl. No.	Features	Essential/Minimum Requirements
1.	Type of Transmitter	Non-contact Microprocessor based 2 wire type (loop powered), HART protocol compatible Ultrasonic transmitter.
2.	Output signal	4-20 mA DC (Analog) along with superimposed digital signal (based on HART protocol).
3.	Accuracy	+/- 0.5% of calibrated span or minimum 5mm.
4.	Power supply	24 V DC +/- 10%.
5.	Temperature compensation	To be provided within transducer.
6.	Housing	Weather proof as per IP-65, metallic housing with durable corrosion resistance coating.
7.	Adjustment/calibration/maintenance	Using hand held HART calibrator/ centralized PC based system (as applicable).
8.	Zero and Span adjustment	Continuous, tamper proof, remote as well as manual adjustability from instrument. It should be possible to calibrate the instrument without any level in the tank/sump etc.
9.	Sensor Material	Corrosion resistant material to suit individual application requirement.
10.	False signal tolerance	Transmitter shall be capable of ignoring false echoes from internal tank/sumps obstructions such as pipes, heating coils or agitator blades. Also transmitter shall have adjustable damping circuitry.
11.	Range	Range of transmitter shall be capable of covering the complete level span of tank taking care of blocking distance, frequency attenuation due to surface, obstructions, vapors etc.
12.	Display	Integral digital display
13.	Diagnostics	Loss of echo alarm etc.
14.	Load Impedance	500 ohms (minimum).
15.	Electrical Connection	Plug and socket
16.	Accessories	<ul style="list-style-type: none"> All weather canopy shall be provided for protection from direct sunlight and direct rain for open locations. All mounting accessories required for erection and commissioning shall be provided. For hazardous area, explosion proof enclosure as described in NEC article 500.

Note:

- (i) Contractor can also provide Radar type transmitter as per above specification in place of ultrasonic transmitter subject to approval by Employer during detailed Engineering. Sonic frequency based transmitters can also be provided under “ultrasonic transmitters” category for fly ash silo level.
- (ii) Four wire type transmitters can also be provided for applications where 2- wire transmitter has some technical limitations, subject to employer’s approval during

detailed engineering stage. However, in such cases isolated 4-20 mA DC (analog) output shall be provided. Power supply required for such transmitters shall be 240V AC / 24V DC.

- (iii) For applications where transmitter location is not accessible, the transmitter shall have separate sensor unit and electronic unit for such applications. It shall be possible to mount the electronic unit at accessible location.

d) SPECIFICATION FOR ULTRA SONIC TYPE LEVEL TRANSMITTER

Sl. No.	Features	Essential/Minimum Requirements
1.	Type of Transmitter	Non-contact Microprocessor based 2 wire type (loop powered), HART protocol compatible Ultrasonic transmitter.
2.	Output signal	4-20 mA DC (Analog) along with superimposed digital signal (based on HART protocol).
3.	Accuracy	+/- 2% of calibrated span.
4.	Power supply	24 V DC +/- 10%.
5.	Temperature compensation	To be provided within transducer.
6.	Housing	Weather proof as per IP-65, metallic housing with durable corrosion resistance coating.
7.	Adjustment/calibration/maintenance	Using hand held HART calibrator/ centralized PC based system (as applicable).
8.	Zero and Span adjustment	Continuous, tamper proof, remote as well as manual adjustability from instrument. It should be possible to calibrate the instrument without any level in the tank/sump etc.
9.	Sensor Material	Corrosion resistant material to suit individual application requirement.
10.	False signal tolerance	Transmitter shall be capable of ignoring false echoes from internal tank/sumps obstructions such as pipes, heating coils or agitator blades. Also transmitter shall have adjustable damping circuitry.
11.	Range	Range of transmitter shall be capable of covering the complete level span of tank taking care of blocking distance, frequency attenuation due to surface, obstructions, vapors etc.
12.	Display	Integral digital display
13.	Diagnostics	Loss of echo alarm etc.
14.	Load Impedance	500 ohms (minimum).
15.	Electrical Connection	Plug and socket
16.	Accessories	<ul style="list-style-type: none"> • All weather canopy shall be provided for protection from direct sunlight and direct rain for open locations. • All mounting accessories required for erection and commissioning shall be provided. • For hazardous area, explosion proof enclosure as described in NEC article 500.

e) SPECIFICATION FOR TEMPERATURE ELEMENTS AND ACCESSORIES

e.1.THERMOCOUPLE

Sl. No.	Features	Essential/Minimum Requirements
1.	Type of Thermocouple.	16 AWG wire of Chromel-Alumel (Type K) or 24 AWG wire Pt-Rhodium Pt (Type R) depending on operating temperature Range (ungrounded separate junction type).
2.	No. of element	Duplex
3.	Housing/Head	IP-65/Diecast Aluminium. Head of TE to be provided with sufficient space and arrangement to mount head mounted temperature transmitter (as applicable). Plug in connectors are to be provided for external signal cable connection. TE terminal head shall be spring loaded for positive contacts with the thermo well.
4.	Insulation and Sheathing of Thermocouple	Swaged type mineral (magnesium oxide) insulation and SS316 sheath.
5.	Calibration and accuracy	As per IEC-584/ ANSI-MC-96.1 (special limits of errors/ class1) for T/C.
6.	Accessories	Thermo well and associated fittings
7.	Standard	IEC-584/ ANSI MC 96.1 for Thermocouple and ASME PTC-19.3 for Thermo-well

e.2.Resistance Temperature Detector (RTD)

Sl. No.	Features	Essential/Minimum Requirements
1.	Type of RTD.	Four wire, Pt-100 (100 Ohms resistance at zero degree Centigrade).
2.	No. of element	Duplex
3.	Housing/Head	IP-65/Diecast Aluminium. Head of TE to be provided with sufficient space and arrangement to mount head mounted temperature transmitter (as applicable). Plug in connectors are to be provided for external signal cable connection. TE terminal head shall be spring loaded for positive contacts with the thermo well
4.	Insulation and Sheathing of Thermocouple	Mineral (magnesium oxide) insulation and SS316 sheath,
5.	Calibration and accuracy	As per As per IEC-751/ DIN-43760 Class-A for RTD
6.	Accessories	Thermo well and associated fittings
7.	Standard	IEC-751/ DIN-43760 for RTD and ASME PTC-19.3 for Thermo-well.

NOTES:

1) The specifications for RTDs of winding/ bearings of motor/pump, can be as per their manufacturer standards. The manufacturer shall submit the adequate supporting documents for establishing their standard practice. However the type of RTD shall be Pt100.

2) The specifications of temp elements for air conditioning & ventilation system / process can be as per system manufacturer's standards. The manufacturer shall submit the adequate supporting documents for establishing their standard practice.

e.3.Metal Temperature Thermocouples

Measuring Medium	Metal Temperature
Material of Thermocouple.	Chromel Alumel Type K
Type of Thermocouple	Duplex with ungrounded separate hot junctions
Insulation	Mineral Insulation (Magnesium Oxide).
Thermocouple wire Gauge	16 AWG
Protective sheath	SS 321
Protective sheath dia	8 mm OD
Calibration & accuracy error) for T/C	As per IEC-584/ ANSI-MC-96.1 (special limits of
Mounting accessories	1/2" BSP SS sliding end connector, weld pad, clamps of heat resistant steel SS310. Adjustable gland fitting for connection at the junction box end as per manufacturer's standard.
Cold end sealing	SS pot seal with colour coded PTFE Insulated flexible tails. Sealing compound- Epoxy resin. Length of PTFE insulated flying leads shall be minimum 750 mm.
Minimum bending Radius	30 mm
Length of T/C	On as required basis considering location of measurement point and the JB/TTJB location.

Notes:

- 1) The specification for thermocouples of bearings metal temp measurements can be as per their manufacturer standards. The manufacturer shall submit the adequate supporting documents for establishing their standard practice. However type of thermocouples shall be K-type.
- 2) For boiler metal temperature applications, considering the location of installations and response time, manufacturer's standard and proven specification for metal temperature measurement can also be accepted subject to employer's approval. The manufacturer shall submit adequate

e.4. **Thermo well (for all process temp. elements)**

Shall be one piece solid bored type of 316 SS of step-less tapered design. (As per ASME PTC 19.3, 1974)

f) SPECIFICATION FOR TEMPERATURE TRANSMITTER (TT)

Following specifications are applicable for Dual input/ Single input temperature transmitter.

Temperature transmitter shall be 2-wire (loop powered) directly powered from 4-20Ma input cards of DDCMIS. TT shall be fully compatible with thermocouples and RTDs being provided by the contractor. Temperature compensation for thermocouples shall be performed in the temperature transmitter itself.

Sl. No.	Features	Essential/Minimum Requirements
1.	Output	2-wire (power supply from input card of control system) with 4-20mA output with superimposed HART protocol signal
2.	Input	Same transmitter shall be capable to handle Pt-100 RTD, Thermocouples –K, R & ,S types (Selectable through HART terminal/calibrator)
3.	Isolation	Min 500 VAC
4.	EMC compatibility	As per EN 61326
5.	Power supply	24 V C +/- 10%
6.	Housing	Weather proof as per IP-67, metallic housing with durable corrosion resistant coating
7.	Electrical connection	Plug and Socket connector except hazardous area
8.	Diagnostics & display	Self-Indicating feature and digital display on transmitter
9.	Operating Ambient temperature	85 deg C without display. 70 deg C with display.
10.	Mounting	2 inch pipe mounting with Canopy.
11.	Accessories	As required by service and operating condition.
12.	Composite Accuracy	(Refer note 2) RTD =<0.25% of 0-250 deg C span T/C-K type =<0.2% of 0-600 deg C span CJC accuracy (for thermocouples) shall be =< 1 deg C

Notes:

1. In case of failure (open or burn-out) of RTD/thermocouple, transmitter shall provide low temperature output.
2. Dual input temperature transmitter shall have bump less changeover facility to second sensor in case first sensor fails. This changeover is to be alarmed in control system.
3. Composite accuracy is to be calculated as summation of all applicable accuracies of temperature transmitter for converting sensor input to output (e.g., A/D accuracy, basic accuracy, digital accuracy, etc.) and temperature effect on these accuracies at ambient

temperature of 50 deg C, based on the figure/ formula given in the standard product catalogue for span as specified above for various types of temperature elements specified. All such accuracy/ temperature effect figures in catalogue shall be first converted to deg C, and then percentage of this converted accuracy in specified span shall be calculated to compare with the specified composite accuracy figures. All temperature transmitters shall be interchangeable (i.e. can be used for either RTD or thermocouple) and composite accuracy shall be met for each type of input as specified above.

4. Above mentioned parameters/features of offered models shall be strictly as defined in standard published catalogue of the manufacturer only.
5. Dual input temperature transmitters can also be accepted in place of single input TT.

g) SPECIFICATION FOR CORIOLIS FLOW TRANSMITTER

Type	Coriolis
Material of Wetted Parts	316 SS
Material of Housing	304L SS
Accuracy	± 0.2% of Rate
Repeatability	± 0.1% of Rate
Output	4-20 mA DC, HART Compatible
Power Supply	230 VAC or 24VDC operated
Process Temperature range	0-200 degree Celsius
Others	Drain / purging arrangement shall be provided as per standard practice.
Viscosity range of Fluid	0-500cst for HFO

The offered Coriolis type flow transmitter shall be suitable for intended application. Contractor shall submit flow and sizing calculation for Employer's approval. For each type of Coriolis type flow transmitter general arrangement and assembly drawing and cable wiring diagram shall be submitted for Employer's approval.

h) SPECIFICATION FOR FLOW ELEMENTS

h.1. Orifice Plate

Features	Essential/Minimum Requirements
Type	Concentric as per ASME PTC-19.5 (Part-II), ISA RP-3.2, 1960 or BS-1042, ISO 5167
Material	316 SS

Thickness	3 mm for main pipe diameter up to 300 mm and 6 mm for main pipe dia above 300 mm.
Material of branch pipe	Same as main pipe
Root valve type	Globe
Root valve material	Same as pipe material
Root valve size	1 / 2 inch or 1 inch (as applicable)
Impulse pipe of same material up to root valve	Required
Tappings	Flanged weld neck or D & D/2 with 3 pairs of tapping (as applicable). Root valves to be provided in all the tappings. However for flow elements in CPU, DM & PT plant- 2 Pairs of Tappings shall be provided as minimum.
Beta Ratio	0.34 to 0.7
Beta Ratio calculation to be Submitted	Yes
Assembly drg. and flow Vs DP Curves	Yes
Accessories	Root valves, flanges, Vent/drain hole(As required)

Bidder shall submit certified flow calculation and differential pressure vs. flow curves for each element for Employer's approval. Sizing calculation, precise flow calculation for all the flow elements, fabrication and assembly drawings and installation drawings shall be submitted for Employer's approval.

h.2. Flow Nozzle

Features	Essential/Minimum Requirements
Type	Long radius, welded type as per ASME PTC- 19.5 (Part-III) or BS-1042
Material	316 SS
Thickness	Suitable for intended application.

Material of branch pipe	Same as main pipe
Root valve type	Globe
Root valve material	Same as pipe material
Root valve size	1 inch

Impulse pipe of same material

up to root valve Required

Tapping Flanged weld neck or D & D/2 with 3 pairs of tapping (as applicable). Root valves to be provided in all the tappings. However for flow elements in CPU, DM & PT plant- 2 Pairs of Tappings shall be provided as minimum.

Beta Ratio Around 0.7

Beta Ratio calculation
to be submitted Yes

Assembly drg. And
flow Vs DP Curves Yes

Accessories Root valves, vent and drain hole.

Contractor shall submit certified flow calculation and differential pressure vs. flow curves for each element for Employer's approval. Sizing calculation, precise flow calculation for all the flow elements, fabrication and assembly drawings and installation drawings shall be submitted for Employer's approval.

h.3. Venturi (For Liquid applications)

Features	Essential/Minimum Requirements
Type	Rough Welded (for Pipe dia between 200mm to 1200mm) or Machined (for Pipe dia 50mm to 250mm) as per ISO 5167-4:2003,
Material	Same as Main Pipe
Thickness	Same as Main Pipe.
Root valve type	Globe Type
Root valve material	Same as Pipe material
Root valve size	1 inch
Impulse pipe of same material up to root valve	Required
Tapping	3 pairs of tappings for each Venturi as per ISO 5167-4:2003, However for some areas like CPU, DM & PT plant- 2 Pairs of Tappings shall be provided as minimum.
Beta Ratio	0.4 to 0.7
Beta Ratio calculation to be Submitted	Yes
Assembly drg. and flow Vs DP Curves	Yes
Accessories	Root valves, vent and drain hole.

Contractor shall submit certified flow calculation and differential pressure vs. Flow curves for each element for employer's approval. Sizing calculation, precise flow calculation for all the flow elements, fabrication and assembly drawings and installation drawings shall be submitted for employer's approval.

i) **SPECIFICATION FOR PROCESS ACTUATED SWITCHES**

FEATURES	ESSENTIAL / MINIMUM REQUIREMENTS		
	Pressure/ Draft Switches/ DP Switches	Temperature switches	Level switches
Sensing Element	Piston actuated for high pressure and diaphragm or bellows for low pr./ vacuum	Vapor pressure sensing, liquid filled bellow type with SS bulb and capillary (5 m minimum, to suit application)	Capacitance types, float type, conductivity type, RF type, Ultrasonic type as per suitability to the application. .
Material	316 SS	Bulb 316 SS/ capillary 304 SS	316 SS
End connection	½ inch NPT (F)	½ inch NPT (F)	Manufacturer standard
Over range/ proof pressure	150% of maximum operating pr.	-	150% of maximum operating pr.
Repeatability	+/- 0.5% of full range		
No. of contacts	2 No.+2NC. SPDT snap action dry contact		
Rating of contacts	60 V DC, 6 VA (or more if required by DDCMIS)		
Elect. Connection	Plug in socket.		
Set point adjustment	Provided over full range.		
Dead band adjustment	Adjustable/ fixed as per requirement of application.		
Enclosure	Weather and dust proof as per IP-55, metallic housing.		
Accessories	Siphon, snubber, chemical seal, pulsation dampeners as required by process	Thermo well of 316 SS and packing glands	All mounting accessories

Mounting	Suitable for enclosure/ mounting or direct mounting	Suitable for rack mounting or direct mounting	-
Power Supply (wherever required)	As per Contractor's Standard practice.		
Notes :-			
<ol style="list-style-type: none"> 1) Where the process fluids are corrosive, viscous, solid bearing or slurry type, diaphragm seals shall be provided. Parts below the diaphragm shall be removable for cleaning. The entire volume above the diaphragm shall be completely filled with an inert liquid suitable for the application. 2) Pressure/ Diff pressure switches for very low press/ DP measurements can have sensor material other than SS316 in case of any technical limitation and the offered product is standard product of the manufacture for very low pressure applications. 3) Repeatability can be upto +/-1% of full range in case of switches with diaphragm seals or very low pressure/DP range. 4) The specifications of switches for air conditioning & ventilation system / process can be as per system manufacturer's standards. The manufacturer shall submit the adequate supporting documents for establishing their standard practice. 			

j) SPECIFICATION FOR PR. GAUGE, D.P. GAUGE, TEMP. GAUGE AND LEVEL GAUGE.

Sl. No	FEATURES	ESSENTIAL/MINIMUM REQUIREMENTS		
		Pr. Gauge/ DP Gauge/ Draught gauges	Temperature Gauge	Level Gauge
1	Sensing Element	Bourdon for high pressure, Diaphragm/ Bellow for low pr.	Inert gas actuated/ Liquid filled other than mercury	Tempered * toughened Borosilicate gauge glass steel armoured reflex or transparent type.
2	Material of sensing element	SS 316	SS 316	
3	Material of movement	SS 304	SS 304	
4	Body material	Die-cast aluminium	Die-cast aluminium	Forged carbon steel/304 SS
5	Dial size	150mm	150 mm	Tubular covering entire range
6	End connection	1/2 inch NPT (M)	1/2 inch or 3/4 inch NPT (M).	Process connection as per ASME PTC and drain/vent 15 NB

7	Accuracy	±1% of span	± 1% of span	± 2%
8	Scale	Linear, 270° arc graduated in metric units	Linear, 270° arc graduated in °C	Linear vertical
9	Range selection	Shall cover 125% of max. operating press	Shall cover 125% of max. operating temp	Shall cover max. Operating level.
10	Over range	125% of FSD	125% of FSD	-
11	Housing	Weather and dust proof as per IP-55	Weather and dust proof as per IP-55	CS/304 SS leak proof
12	Zero/span adjustment	Provided	Provided	-
13	Identification	Engraved with service legend or laminated phenolic name plate		
14	Accessories	Blow out disc, siphon, snubber, pulsation dampener, chemical seal (if required by process) gauge isolation valve	SS Thermowell	Gasket for all KEL-F shield for transparent type vent and drain valves of Steel/SS as per CS/Alloy process Requirement.
Notes:-				
*Bicolour type level gauges will be provided for applications involving steam and water except for condensate and feed water services.				
Length of gauge glass shall not be more than 1400 mm. If the vessel is higher, multiple gauge glasses with 50 mm overlapping shall be provided.				
Where the process fluids are corrosive, viscous, solid bearing or slurry type, diaphragm seals shall be provided. Parts below the diaphragm shall be removable for cleaning. The entire volume above the diaphragm shall be completely filled with an inert liquid suitable for the application.				

k) SPECIFICATION FOR SOLENOID VALVES

Solenoid valves shall fulfil the following requirements:

- a. Type 2/3/4 way SS 316/Forged Brass (depending on the application subject to Employer's approval during detailed Engg.)
- b. Power supply : 24 V DC + 10%.
- c. Plug and socket electrical connection.
- d. Insulation : Class 'H'
- e. IP Class : IP65

l) SPECIFICATION FOR LIMIT SWITCHES

Limit switches shall be silver plated with high conductivity and non-corrosive type. Contact rating shall be sufficient to meet the requirement of DDCMIS subject to a minimum of 60 V, 6 VA rating. Protection class shall be IP 55.

m) SPECIFICATION FOR ELECTRONIC FLOW-METER

Electronic Flow-meters shall be provided where ever indicated in the P&ID s.

The Electronic flow meter shall include flow sensor and flow indicator cum integrator/totaliser and shall include all required accessories for satisfactory operation. The flow meter shall be based on full bore ultrasonic/electromagnetic principle and shall be based on full bore ultrasonic/electromagnetic principle and shall electronic type of proven design, make and model acceptable to the owner.

The bidder shall submit all necessary technical literature and details of selection criteria of the instrument offered to substantiate the model selected. The bidder shall also furnish list of similar installation along with feedback on satisfactory performance of the instruments.

The flow meter shall meet or exceed the following equipment:

- a) Output: 4-20 mA Dc isolated output
- b) Accuracy $\pm 0.5\%$ of calibrated span or better
- c) Repeatability $\pm 0.2\%$ of calibrated span or better
- d) Ambient Temp & Humidity 4 Deg. C to 55 Deg C , 5% to 100% RH

- | | |
|---------------------|---|
| e) Power Supply | 240V AC \pm 10%, 50 HZ \pm 5% / 24 V DC, to be arranged by the bidder |
| f) Protection Class | IP-55 |
| g) Flow Tube | SS 304 |
| h) Liner | Hard Rubber |

The Flow meter shall provide local indication for instantaneous flow. It should also be possible to get local display for daily and monthly discharge. The flow meter shall indicate totalizer/integrator to get the daily and monthly discharge as stated above.

TECHNICAL SPECIFICATION OF MOTORS

GENERAL REQUIREMENTS

- For the purpose of design of equipment/systems, an ambient temperature of 50 deg. Centigrade and relative humidity of 95% (at 40 deg C) shall be considered. The equipment shall operate in a highly polluted environment.
- All equipment shall be suitable for rated frequency of 50 Hz with a variation of +3% & -5%, and 10% combined variation of voltage and frequency unless specifically brought out in the specification.
- Contractor shall provide fully compatible electrical system, equipment, accessories and services.
- All the equipment, material and systems shall, in general, conform to the latest edition of relevant National and international Codes & Standards, especially the Indian Statutory Regulations.
- Paint shade shall be as per RAL 5012 (Blue) for indoor and outdoor equipment.
- The responsibility of coordination with electrical agencies and obtaining all necessary clearances for contractors equipment and systems shall be under the contractor scope.

Degree of Protection

Degree of protection for various enclosures as per IEC60034-05 shall be as follows:-

- i) Indoor motors - IP 54
- ii) Outdoor motors - IP 55
- iii) Cable box-indoor area - IP 54
- iv) Cable box-Outdoor area - IP 55

CODES AND STANDARDS

- 1) Three phase induction motors : IS/IEC:60034
- 2) Single phase AC motors : IS/IEC:60034
- 3) Crane duty motors : IS:3177, IS/IEC:60034
- 4) DC motors/generators : IS/IEC:60034
- 5) Energy Efficient motors : IS 12615, IEC: 60034-30

TYPE

AC Motors:

- a) Squirrel cage induction motor suitable for direct-on-line starting.
- b) Continuous duty LT motors upto 200 KW Output rating (at 50 deg.C ambient temperature), shall be Premium Efficiency class-IE3, conforming to IS 12615, or IEC:60034-30. HT motors shall have minimum design efficiency of 95 % Tolerance on efficiency value applicable as per IEC 60034.
- c) Crane duty motors shall be squirrel cage Induction motor as per the requirement.
- d) Motor operating through variable frequency drives shall be suitable for inverter duty with VPI insulation. Also these motors shall comply the requirements stipulated in IEC: 60034-18-41 and IEC: 60034-18-42 as applicable.
- e) Motors operating through variable frequency drives shall also meet the requirements mentioned in subsection for VFD.

RATING

- (a) Continuously rated (S1). However, crane motors shall be rated for S4 duty, 40% cyclic duration factor.
- (b) Whenever the basis for motor or driven equipment ratings are not specified in the corresponding mechanical specification sub-sections, maximum continuous motor ratings shall be at least 10% above the maximum load demand of the driven equipment under entire operating range including voltage and frequency variations.

TEMPERATURE RISE

Air cooled motors

70 deg. C by resistance method for both thermal class 130(B) & 155(F) insulation.

Water cooled

80 deg. C over inlet cooling water temperature mentioned elsewhere, by resistance method for both thermal class 130(B) & 155(F) insulation. 41 deg.C over inlet cooling water maximum temperature of 39 deg.C for thermal class 90 (Y) wet wound Boiler circulation pump motor.

OPERATIONAL REQUIREMENTS

Starting Time

For motors with starting time upto 20 secs at minimum permissible voltage during starting, the locked rotor withstand time under hot condition at highest voltage limit shall be at least 2.5 sec more than starting time.

For motors with starting time more than 20 secs and upto 45 secs at minimum permissible voltage during starting, the locked rotor withstand time under hot condition at highest voltage limit shall be at least 5 secs. more than starting time.

For motors with starting time more than 45 secs. at minimum permissible voltage during starting, the locked rotor withstand time under hot condition at highest voltage limit shall be more than starting time by at least 10% of the starting time.

Speed switches mounted on the motor shaft shall be provided in cases where above requirements are not met.

Torque Requirements

Accelerating torque at any speed with the lowest permissible starting voltage shall be at least 10% motor full load torque.

Pull out torque at rated voltage shall not be less than 205% of full load torque. It shall be 275% for crane duty motors.

Starting voltage requirement

- (a) Up to 85% of rated voltage for ratings below 110 KW
- (b) Up to 80% of rated voltage for ratings from 110 KW to 200 KW
- (c) Up to 85% of rated voltage for ratings from 201 KW to 1000 KW
- (d) Up to 80% of rated voltage for ratings from 1001 KW to 4000 KW
- (e) Up to 75 % of rated voltage for ratings above 4000KW

Except AOP & JOP motors running on D.G emergency supply, starting voltage shall be 80%.

DESIGN AND CONSTRUCTIONAL FEATURES

Suitable single phase space heaters shall be provided on motors rated 30KW and above to maintain windings in dry condition when motor is standstill. Separate terminal box for space heaters & RTDs shall be provided. However for flame proof motors, space heater terminals inside the main terminal box may be acceptable.

All motors shall be either Totally enclosed fan cooled (TEFC) or totally enclosed tube ventilated (TETV) or Closed air circuit air cooled (CACA) type. However, motors rated 3000KW or above can be Closed air circuit water cooled (CACW). The method of movement of primary and secondary coolant shall be self-circulated by fan or pump directly mounted on the rotor of the main motor as per IEC 60034-6. However VFD driven motors can be offered with forced cooling type with machine mounted fan or pump driven by separate electric motor. Motors and EPB located in hazardous areas shall have flame proof enclosures conforming to IS: 2148 as detailed below

(a) Fuel oil area: Group – IIB

(b) Hydrogen generation: Group - IIC or (Group-I, Div-II as per plant area NEC) or (Class-1, Group-B, Div-II as per NEMA / IEC60034)

Winding and Insulation

(a) Type: Non-hygroscopic, oil resistant, flame resistant

(b) Starting duty: Two hot starts in succession, with motor initially at normal running temperature.

(c) 240VAC, 415V AC & 220V DC motors: Thermal Class (B) or better

Motors with heat exchangers shall have dial type thermometer with adjustable alarm contacts to indicate inlet and outlet primary air temperature.

Noise level for all the motors shall be limited to 85dB (A). Vibration shall be limited within the limits prescribed in IS/IEC 60034-14. Motors shall withstand vibrations produced by driven equipment. HT motor bearing housings shall have flat surfaces, in both X and Y directions, suitable for mounting 80mmX80mm vibration pads.

Motor body shall have two earthing points on opposite sides.

The spacing between gland plate & center of bottom terminal stud shall be as per Table-I.

All motors shall be so designed that maximum inrush currents and locked rotor and pullout torque developed by them at extreme voltage and frequency variations do not endanger the motor and driven equipment.

The motors shall be suitable for bus transfer schemes provided on the 11kV, 3.3 Kv /415V systems without any injurious effect on its life.

The size and number of cables (for HT and LT motors) to be intimated to the successful bidder during detailed engineering and the contractor shall provide terminal box suitable for the same.

The ratio of locked rotor KVA at rated voltage to rated KW shall not exceed the following (without any further tolerance).

- (a) From 50KW & upto 110KW : 11.0
- (b) From 110 KW & upto 200 KW : 9.0
- (c) Above 200 KW & upto 1000KW : 10.0
- (d) From 1001KW & upto 4000KW : 9.0
- (e) Above 4000KW : 6 to 6.5

TYPE TEST

LT Motors supplied shall be of type tested design. During detailed engineering, the contractor shall submit for employer's approval the reports of all the type tests as listed in this specification and carried out within last *ten* years from the date of bid opening. These reports should be for the test conducted on the equipment similar to those proposed to be supplied under this contract and the test(s) should have been either conducted at an independent laboratory or should have been witnessed by a client.

However if the contractor is not able to submit report of the type test(s) conducted within last ten years from the date of bid opening, or in the case of type test report(s) are not found to be meeting the specification requirements, the contractor shall conduct all such tests under this

contract at no additional cost to the employer either at third party lab or in presence of client/ employer's representative and submit the reports for approval.

LIST OF TESTS FOR WHICH REPORTS HAVE TO BE SUBMITTED

The following type test reports shall be submitted for each type and rating of LT motor of above 100 KW only

1. Measurement of resistance of windings of stator and wound rotor.
2. No load test at rated voltage to determine input current power and speed
3. Open circuit voltage ratio of wound rotor motors (in case of Slip ring motors)
4. Full load test to determine efficiency power factor and slip.
5. Temperature rise test.
6. Momentary excess torque test.
7. High voltage test.
8. Test for vibration severity of motor.
9. Test for noise levels of motor (Shall be limited to 85dB (A)).
10. Test for degree of protection and
11. Over speed test.
12. Type test reports for motors located in fuel oil area having flame proof enclosures as per IS 2148 / IEC 60079-1

All acceptance and routine tests as per the specification and relevant standards shall be carried out. Charges for these shall be deemed to be included in the equipment price.

The type test reports once approved for any projects shall be treated as reference.

For subsequent projects of NTPC, an endorsement sheet will be furnished by the manufacturer confirming similarity and "No design Change". Minor changes if any shall be highlighted on the endorsement sheet.

TABLE - I
DIMENSIONS OF TERMINAL BOXES FOR LV MOTORS

Motor MCR in KW

**Minimum distance between centre of
bottom terminal stud and gland plate in mm**

UP to 3 KW

As per manufacturer's practice.

Above 3 KW - upto 7 KW	85
Above 7 KW - upto 13 KW	115
Above 13 KW - upto 24 KW	167
Above 24 KW - upto 37 KW	196
Above 37 KW - upto 55 KW	249
Above 55 KW - upto 90 KW	277
Above 90 KW - upto 125 KW	331
Above 125 KW-upto 200 KW	385/203 (For Single core cables only)

PHASE TO PHASE/ PHASE TO EARTH AIR CLEARANCE:

NOTE: Minimum inter-phase and phase-earth air clearances for LT motors with lugs installed shall be as follows:

Motor MCR in KW	Clearance
UP to 110 KW	10mm
Above 110 KW and upto 150 KW	12.5mm
Above 150 KW	19mm

LT MOTOR APPROVED VENDORS ARE GIVEN BELOW. HT MOTORS TO BE SOURCED FROM SHEL/ABB/SIEMENS

04	LT MOTORS	a) KEC	Bangalore/ Hubli (Up to 90KW)	Please refer remark column for Categorization	BAP/QR/ G501 & G502/LTM:012 Rev NO: 00 dt 17 05 2018	Cat I Above 50 KW and up to 200KW NTPC insp as per appd RQP/MQP
		c) CGL	Ahmednagar	Please refer remark column for Categorization		
		b) SIEMENS	Mumbai	** Acceptance of Motor rating between 30KW to 50 KW is based on NTPC Review of Routine Test Inspection report as per IS 325 Witnessed by BHEL/BHEL AIA ie Main contractor along with COC of the manufacturer and the contractor confirming as follows: "It is hereby confirmed that the above mentioned motor was /motors were manufactured taking care of NTPC specific requirements regarding ambient temperature, voltage and frequency variation, hot starts , pull out torque, starting KVA/KW, temperature rise, distance between centre of stud and gland plate, space heater and in accordance with approved drawing /data sheets"		Cat-II **From 30KW to 50KW BHEL Inspection
		c)ABB	Faridabad up to 55KW/ Bangalore above 55KW			
		a) BBL	Mumbai			
		b) NGEF	Hubli (up to15KW)			
		c) Marathon	Kolkata			
		d) Jyoti	Vadodara			
		e) LHP	Solapur			
		(For other PMD vendors except above NTPC approved vendors, pl refer Sino. 4 under important notes in page no:11)		##Acceptance of Motor less than 30KW is based on COC of the manufacturer and the contractor conforming as follows: "It is here by confirmed that the above mentioned motor/motor was / were manufactured taking care of NTPC specific requirements regarding ambient temperature, voltage and frequency variation, hot starts , pull out torque, starting KVA/KW, temperature rise ,distance between centre of stud and gland plate and tested m accordance with approved drawing /data sheet".	# #Cat-III Up to 30KW	

Prepared by: C(.
(Ch.Anil Singh)
Dy. Engineer/QA (Electrics)

Reviewed by: *g.H-*
(S.Sheela)
Dy.Manager/QA (Electrics) & System

Approved by: *4: T. [Signature]*
(K. iParimalam)
DGM /QA (Electrics)

INSTRUMENTATION CABLE, CONTROL & POWER SUPPLY CABLE, INTERNAL WIRING AND ELECTRICAL FIELD CONSTRUCTION MATERIAL

General requirements

- All cables including special cables, internal wiring and electrical field construction material shall conform to this specification, Employer approved detail engineering drawings & documents and the latest edition of the relevant standards & guidelines. The Bidder shall furnish all material and services required for the completeness of the work identified in his scope as per this specification.
- The Contractor shall supply, erect, terminate and test all instrumentation cables for control and instrumentation equipment/devices/systems included under Contractor's scope and ensuring completeness of the control system.
- Any other application where it is felt that instrumentation cables are required due to system/operating condition requirements, are also to be provided by Contractor.
- Other type of cables like fiber optic/co-axial cables for system bus, cables for connection of peripherals etc. (under Contractor's scope) are also to be furnished by the Contractor.
- Contractor shall supply all cable erection and laying hardware from the main trunk routes like branch cable trays/sub-trays, supports, flexible conduits, cable glands, lugs, pull boxes etc. on as required basis for all the systems covered under this specification.
- Wherever the quantity has been defined as on as required basis, the same are to be furnished by contractor on as required basis within his quoted lump sum price without any further cost implication to the Employer.

SPECIFICATION OF INSTRUMENTATION CABLE

Common Requirements

S. No.	Property	Requirement
1	Operating Voltage	225 V (peak value)
2.	Codes and standard	All instrumentation cables shall comply with VDE 0815, VDE 0207, Part 4, Part 5, Part 6, VDE 0816, VDE 0472, SEN 4241475, ANSI MC 96.1, IS-8784, IS-10810 (latest editions) and their amendments read along with this specification.
3.	Continuous operation suitability	At 205 Deg C for Type-C cables & heat resistant cables, at 70 Deg C for all other type of cables.
4.	Marking :-	<p>a. <i>Progressive automatic on-line sequential marking of length in meters to be provided at every one meter on outer sheath.</i></p> <p>b. Marking to read 'FRLS' to be provided at every 5 meters on outer sheath except for Type-C cable</p> <p>c. Durable marking at intervals not exceeding 625 mm shall include manufacturer's name, insulation material, conductor's size, number of pairs, voltage rating, type of cable, year of manufacturer to be provided on outer sheath.</p>

S. No.	Property	Requirement
5.	Allowable Tolerance on overall diameter	+/- 2 mm (maximum) over the declared value in data sheet
6.	Variation in diameter	Not more than 1.0 mm throughout the length of cable.
7.	Ovality at any cross-section	Not more than 1.0 mm
8.	CAGE-CLAMP suitability	To be provided
9.	Color	The outer sheath shall be of blue color.
10.	Others	Repaired cables shall not be acceptable.

Specific Requirements

Specification Requirements	Type-A cable	Type-B cable	Type F & G cable	Type-C cable
A. CONDUCTORS				
Cross section area	0.5 sq. mm			
Conductor material	ANSI type KX	ANSI type SX	Annealed bare copper	ANSI type KX
Colour code	Yellow-Red	Black-Red	As per VDE-815	Yellow-Red
Conductor Grade	As per ANSI MC 96.1		Electrolytic	As per ANSI MC 96.1
No & dia of strands	7x0.3 mm (nom)			
No. of Pairs	2	2	2/4/8/12/16/24 / 48	2
Max. conductor loop resistance per Km (in ohm) at 20 deg. C	As per ANSI MC 96.1		73.4	As per ANSI MC 96.1
Reference Standard	As per ANSI MC 96.1		VDE : 0815	As per ANSI MC 96.1

Specification Requirements	Type-A cable	Type-B cable	Type F & G cable	Type-C cable
B. INSULATION				
Material	Extruded PVC type YI 3			Teflon (i.e. extruded FEP)
Thickness in mm (Min/Max)	0.25/0.35			0.4 / 0.50 (nominal)
Volume Resistivity (Min) in ohm-cm	1 x 10 ¹⁴ at 20 deg. C & 1x10 ¹¹ at 70 deg. C.			2.8x 10 ¹⁴ at 20 deg. C & 2x10 ¹¹ at 205 deg. C.
C. PAIRING & TWISTING				
Max. lay of pairs (mm)	50			
Single layer of binder tape on each pair provided	Each core printed with number or Numbered binder tape to be provided on each pair		Yes	Each core printed with number or Numbered binder tape to be provided on each pair
Bunch (Unit Formation) for more than 4P	N.A		To be provided	N.A
Conductor /pair identification as per VDE0815	N.A.		To be provided	N.A.
D. SHIELDING				
Type of shielding	Al-Mylar tape			
Individual pair shielding	No		To be provided for F-type cable	No
Minimum thickness of Individual pair shielding	No		0.028mm (28 micron)	No
Overall cable assembly shielding	To be provided			
Minimum thickness of Overall cable assembly shielding	0.055 mm (55 micron)			
Coverage /	100% / 20%			

Specification Requirements	Type-A cable	Type-B cable	Type F & G cable	Type-C cable
Overlapping				
Drain wire provided for individual shield	N.A.	Yes (for F-type) Size- 0.5 sqmm No of strands-7 Dia of strands- 0.3mm Annealed Tin coated copper	N.A.	
Drain wire provided for overall shield	Yes, Size- 0.5 sqmm, No of strands-7, Dia of strands- 0.3mm, Annealed Tin coated copper			
E. FILLERS (if applicable)				
Non-hygroscopic, flame retardant	To be provided			
F. OUTER SHEATH				
Material	Extruded PVC compound YM1 with FRLS properties		Teflon (i.e. extruded FRP)	
Minimum Thickness at any point	1.8 mm		0.4 mm	
Nominal Thickness at any point	>1.8 mm		0.5 mm	
Resistant to water, fungus, termite & rodent attack	Required			
Minimum Oxygen index as per ASTM D-2863	29 %		N.A.	
Minimum Temperature index as per ASTM D-2863	250 deg.C		N.A.	
Maximum Acid gas generation by weight as per IEC-60754-1	20%		N.A.	
Maximum Smoke Density Rating as per ASTM D-2843	60%		N.A.	
	(defined as the average area under the curve when the results of smoke density test			

Specification Requirements	Type-A cable	Type-B cable	Type F & G cable	Type-C cable
	plotted on a curve indicating light absorption vs. time as per ASTM D-2843)			
Reference standard	VDE207 Part 5, VDE-816			VDE207 Part 6 ASTM D2116
G. Electrical Parameters				
Mutual Capacitance Between Conductors At 0.8 KHz (Max.)	200 nF/km		120 nF/km for F type 100 nF/km for G-type	200 nF/km
Insulation Resistance (Min.)	100 M Ohm/Km			
Cross Talk Figure (Min.) At 0.8 KHz	60 dB		60 dB	60dB
Characteristic Impedance (Max) At 1 KHz	N.A.		320 OHM FOR F-TYPE 340 OHM FOR G-TYPE	N.A.
Attenuation Figure At 1 KHz (Max)	N.A.		1.2 db/km	N.A.
H. COMPLETE CABLE				
Complete Cable assembly	Shall pass Swedish Chimney test as per SEN-SS 4241475 class F3.			N.A.
Flammability	Shall pass flammability as per IEEE-383 read in conjunction to this specification			As per manufacturer's standard subject to employer's approval
I. CABLE DRUM				
Type	Non-returnable wooden drum (wooden drum to be constructed from seasoned wood free from defects with wood preservative applied to entire drum) or steel drum.			

Specification Requirements	Type-A cable	Type-B cable	Type F & G cable	Type-C cable
Length	1000 m \pm 5% for up to & including 12 pairs 500 m \pm 5% for above 12 pairs			

Note: Heat resistant instrumentation cable shall have same specification as of G/F type instrumentation cable as specified above, except that insulation and outer sheath material shall be Teflon and cable shall be suitable for continuous operation at 205 Deg. C.

SPECIFICATION OF OPTICAL FIBER CABLES (OFC)

Optic Fiber cable shall be 4/8/12 core, Electrolytically chrome plated corrugated steel taped (ECCST), fully water blocked with dielectric central member for outdoor/indoor application so as to prevent any physical damage. The cable shall have multiple single-mode or multi-mode fibers on as required basis so as to avoid the usage of any repeaters. The outer sheath shall have Flame Retardant, UV resistant properties and are to be identified with the manufacturer's name, year of manufacturer, progressive automatic sequential on-line marking of length in meters at every meter.

The cable core shall have suitable characteristics and strengthening for prevention of damage during pulling viz. Dielectric central member, Loose buffer tube design, 4 fibers per buffer tube (minimum), Interstices and buffer tubes duly filled with Thixotropic jelly etc. The cable shall be suitable for a maximum tensile force of 2000 N during installation, and once installed, a tensile force of 1000 N minimum. The compressive strength of cable shall be 3000 N minimum & crush resistance 4000 N minimum. The operating temperature shall be – 20 deg. C to 70 deg.C

All testing of the fiber optic cable being supplied shall be as per the relevant IEC, EIA and other international standards.

Bidder to ensure that minimum 100% cores are kept as spares in all types of optical fibre cables.

Cables shall be suitable for laying in conduits, ducts, trenches, racks and under ground buried installation.

Spliced / Repaired cables are not acceptable.

Penetration of water resistance and impact resistance shall be as per IEC standard.

SPECIFICATION OF LT POWER SUPPLY CABLES

All standards, specifications and codes of practice referred to herein shall be the latest editions including all applicable official amendments and revisions as on date of opening of bid. In case of conflict between this specification and those (IS: codes, standards, etc.) referred to herein, the former shall prevail. All the cables shall conform to the requirements of the following standards and codes:

IS: 1554 - I PVC insulated (heavy duty) electric cables for working voltages upto and including 1100V.

IS: 3961 Recommended current ratings for cables

IS: 3975 Low carbon galvanized steel wires, formed wires and tapes for armouring of cables.

IS: 5831 PVC insulation and sheath of electrical cables.

IS: 7098 (Part -I) Cross linked polyethylene

insulated PVC sheathed cables for working voltages upto and including 1100V.

IS: 8130 Conductors for insulated electrical cables and flexible cords.

IS: 10418 Specification for drums for electric cables.

IS: 10810 Methods of tests for cables.

ASTM-D -2843 Standard test method for density of smoke from the burning or decomposition of plastics.

IEC-754

(Part-I) Tests on gases evolved during combustion of electric cables.

IEC-332 Tests on electric cables under fire conditions. Part-3: Tests on bunched wires or cables (Category-B).

TECHNICAL REQUIREMENTS

The cables shall be suitable for laying on racks, in ducts, trenches, conduits and underground buried installation with chances of flooding by water.

All cables including EPR cables shall be flame retardant, low smoke (FRLS) type designed to withstand all mechanical, electrical and thermal stresses developed under steady state and transient operating conditions as specified elsewhere in this specification.

Aluminium conductor used in power cables shall have tensile strength of more than 100 N/ sq.mm. Conductors shall be stranded.

XLPE insulation shall be suitable for a continuous conductor temperature of 90 deg.C and short circuit conductor temperature of 250 deg C. PVC insulation shall be suitable for continuous conductor temperature of 70 deg C and short circuit conductor temperature of 160 deg. C.

The cable cores shall be laid up with fillers between the cores wherever necessary.

It shall not stick to insulation and inner sheath. All the cables, other than single core unarmoured cables, shall have distinct extruded PVC inner sheath of black colour as per IS: 5831.

For single core armoured cables, armouring shall be of aluminium wires/ formed wires. For multicore armoured cables, armouring shall be of galvanized steel as follows:

Calculated nominal dia. of cable under armour	Size and Type of armour
Upto 13 mm	1.4mm dia GS wire
Above 13 & upto 25mm	0.8 mm thick GS formed wire / 1.6 mm dia GS wire
Above 25 & upto 40 mm	0.8mm thick GS formed wire / 2.0mm dia GS wire
Above 40 & upto 55mm	1.4 mm thick GS formed wire /2.5mm dia GS wire
Above 55 & upto 70 mm	1.4mm thick GS formed wire / 3.15mm dia GS wire
Above 70mm	1.4 mm thick GS formed wire / 4.0 mm dia GS wire

The aluminium used for armouring shall be of H4 grade as per IS: 8130 with maximum resistivity of 0.028264 ohm mm² per meter at 20 deg C. The sizes of aluminium armouring shall be same as indicated above for galvanized steel.

The gap between armour wires / formed wires shall not exceed one armour wire / formed wire space and there shall be no cross over / over-riding of armour wire / formed wire. The minimum area of coverage of armouring shall be 90%. The breaking load of armour joint shall not be less than 95% of that of armour wire / formed wire. Zinc rich paint shall be applied on armour joint surface of G.S.wire/ formed wire.

Outer sheath shall be of PVC as per IS: 5831 & black in colour. In addition to meeting all the requirements of Indian standards referred to, outer sheath of all the cables shall have the following FRLS properties.

- (a.) Oxygen index of min. 29 (as per IS 10810 Part-58).
- (b.) Acid gas emission of max. 20% (as per IEC-754-I).
- (c.) Smoke density rating shall not be more than 60 % (as per ASTM D-2843).

Cores of the cables shall be identified by colouring of insulation. Following colour scheme shall be adopted:

- 1 core - Red, Black, Yellow or Blue**
- 2 core - Red & Black**
- 3 core - Red, Yellow & Blue**
- 4 core - Red, Yellow, Blue and Black**

For reduced neutral conductors, the core shall be black

In addition to manufacturer's identification on cables as per IS, following marking shall also be provided over outer sheath.

- (a.) Cable size and voltage grade - To be embossed
- (b.) Word 'FRLS' at every 5 metre - To be embossed
- (c.) Sequential marking of length of the cable in metres at every one metre
-To be embossed / printed

The embossing shall be progressive, automatic, in line and marking shall be legible and indelible. For EPR cables identification shall be printed on outer sheath.

All cables shall meet the fire resistance requirement as per Category-B of IEC 332 Part-3.

Allowable tolerances on the overall diameter of the cables shall be ± 2 mm maximum, over the declared value in the technical data sheets.

In plant repairs to the cables shall not be accepted. Pimples, fish eye, blow holes etc. are not acceptable.

Cable selection & sizing:

Cables shall be sized based on the following considerations:

- (a) Rated current of the equipment.
- (b) The voltage drop in the cable, during motor starting condition, shall be limited to 10% and during full load running condition, shall be limited to 3% of the rated voltage.
- (c) Short circuit withstand capability
This will depend on the feeder type. For a fuse protected circuit, cable should be sized to withstand the let-out energy of the fuse. For breaker controlled feeder, cable shall be capable of withstanding the system fault current level for total breaker tripping time inclusive of relay pickup time.

Cable lengths shall be considered in such a way that straight through cable joints are avoided.

All Cables shall be of armoured type.

All LT power cables of sizes more than 120 sq.mm shall be XLPE insulated and sizes shall be of 1Cx150, 1Cx300, 1Cx630, 3Cx150 & 3Cx240 sq.mm. However for cable sizes up to 120 sq.mm both XLPE insulated & PVC insulated LT power cables are acceptable.

Same cable sizes to be used for same type & rating of motor i.e. if there are three pumps for one application, all three pumps motor should be provided with same cables sizes.

Type Tests

The reports for the following type tests shall be submitted for one size each of LT XLPE and LT PVC Power cables. Size shall be decided by the employer during detailed engineering:

S.No.	Type test	Remarks
	For Conductor	
1.	Resistance test	
2.	Tensile test	For circular non-compacted conductors only
3.	Wrapping test	For circular non-compacted only
	For Armour Wires/ Formed Wires	
4.	Measurement of Dimensions	
5.	Tensile Test	
6.	Elongation test	
7.	Torsion test	For round wires only
8.	Wrapping test	For aluminium wires / formed wires only.
9.	Resistance test	
10(a)	Mass of zinc coating test	For GS Formed wires/wires only
10(b)	Uniformity of zinc coating	For GS Formed wires /wires only
11.	Adhesion test	For GS Formed wires/wires only
	For PVC/XLPE insulation & PVC Sheath	
12.	Test for thickness	

- | | | |
|-----|--|------------------------------------|
| 13. | Tensile strength & elongation before ageing and after ageing tests | |
| 14. | Ageing in air oven | |
| 15. | Loss of mass test | For PVC insulation and sheath only |
| 16. | Hot deformation test | For PVC insulation and sheath only |
| 17. | Heat shock test | For PVC insulation and sheath only |
| 18. | Shrinkage test | |
| 19. | Thermal stability test | For PVC insulation and sheath only |
| 20. | Hot set test | For XLPE insulation only |
| 21. | Water absorption test | For XLPE insulation only |
| 22. | Oxygen index test | For outer sheath only |
| 23. | Smoke density test | For outer sheath only |
| 24. | Acid gas generation test | For outer sheath only |
| | For completed cables | |
| 25. | Insulation resistance test
(Volume resistivity method) | |
| 26. | High voltage test | |
| 27. | Flammability test as per IEC-332 Part-3 (Category-B) | |

Indicative list of tests/checks, Routine and Acceptance tests shall be as per Quality Assurance & Inspection table of LT power cables enclosed.

LT CONTROL CABLES

All standards, specifications and codes of practice referred to herein shall be the latest editions including all applicable official amendments and revisions as on date of opening of bid. In case of conflict between this specification and those (IS : codes, standards, etc.) referred to herein, the former shall prevail. All the cables shall conform to the requirements of the following standards and codes:

IS :1554 - IPVC insulated (heavy duty) electric cables for working voltages up to and including 1100V.

IS : 3961 Recommended current ratings for cables

IS : 3975 Low carbon galvanized steel wires, formed wires and tapes for armouring of cables.

IS : 5831 PVC insulation and sheath of electrical cables.

IS : 8130 Conductors for insulated electrical cables and flexible cords.

IS : 10418 Specification for drums for electric cables.

IS : 10810 Methods of tests for cables.

ASTM-D –2843 Standard test method for density of smoke from the burning or decomposition of plastics.

IEC-754 (Part-I) Tests on gases evolved during combustion of electric cables.

IEC-332 Tests on electric cables under fire conditions. Part-3: Tests on bunched wires or cables (Category-B).

TECHNICAL REQUIREMENTS

The cables shall be suitable for laying on racks, in ducts, trenches, conduits and underground buried installation with chances of flooding by water.

All cables including EPR cables shall be flame retardant, low smoke (FRLS) type designed to withstand all mechanical, electrical and thermal stresses develop under steady state and transient operating conditions as specified elsewhere in this specification.

Conductor of control cables shall be made of stranded, plain annealed copper.

PVC insulation shall be suitable for continuous conductor temperature of 70 deg C and short circuit conductor temperature of 160 deg. C.

The cable cores shall be laid up with fillers between the cores wherever necessary. It shall not stick to insulation and inner sheath. All the cables, other than single core unarmoured cables, shall have distinct extruded PVC inner sheath of black colour as per IS: 5831.

For multicore armoured cables, the armouring shall be of galvanized steel as follows:

Calculated nominal dia

of cable under armour	Size and Type of armour
Up to 13 mm	1.4mm dia GS wire
Above 13 upto 25 mm	0.8 mm thick GS formed wire / 1.6 mm dia GS wire
Above 25 upto 40 mm	0.8mm thick GS formed wire / 2.0mm dia GS wire
Above 40 upto 55mm	1.4 mm thick GS formed wire/2.5mm dia GS wire
Above 55 upto 70 mm	1.4mm thick GS formed wire / 3.15mm dia GS wire
Above 70mm	1.4 mm thick GS formed wire / 4.0 mm dia GS wire

The gap between armour wires / formed wires shall not exceed one armour wire / formed wire space and there shall be no cross over / over-riding of armour wire / formed wire. The minimum area of coverage of armouring shall be 90%. The breaking load of armour joint shall not be less than 95% of that of armour wire / formed wire. Zinc rich paint shall be applied on armour joint surface.

Outer sheath shall be of PVC as per IS: 5831 and grey in colour. In addition to meeting all the requirements of Indian Standards referred to, outer sheath of all the cables shall have the following FRLS properties.

- (a.) Oxygen index of min. 29. (As per IS 10810 Part-58)
- (b.) Acid gas emission of max. 20% (As per IEC-754-I)
- (c.) Smoke density rating shall not be more than 60% during Smoke Density Test as per ASTM D-2843.

Cores of the cables of upto 5 cores shall be identified by colouring of insulation. Following colour scheme shall be adopted.

- 1 core - Red, Black, Yellow or Blue
- 2 core - Red & Black
- 3 core - Red, Yellow & Blue
- 4 core - Red, Yellow, Blue and Black
- 5 core - Red, Yellow, Blue, Black and Grey

For cables having more than 5 cores, core identification shall be done by numbering the insulation of cores sequentially, starting by number 1 in the inner layer (e.g. say for 10 core cable, core numbering shall be from 1 to 10). The number shall be printed in Hindu-Arabic numerals on the outer surfaces of the cores. All the numbers shall be of the same colour, which shall contrast with the colour of insulation. The colour of insulation for all the cores shall be grey only. The numerals shall be legible and indelible. The numbers shall be repeated at regular intervals along the core, consecutive numbers being inverted in relation to each other. When the number is a single numeral, a dash shall be placed underneath it. If

the number consists of two numerals, these shall be disposed one below the other and a dash placed below the lower numeral. The spacing between consecutive numbers shall not exceed 50 mm.

In addition to manufacturer's identification on cables as per IS, following marking shall also be provided over outer sheath:

- (a.) Cable size and voltage grade - To be embossed
 - (b.) Word 'FRLS' at every 5 metre - To be embossed
 - (c.) Sequential marking of length of the cable in metres at every one metre - To be embossed / printed.
- The embossing / printing shall be progressive, automatic, in line and marking shall be legible and indelible. For EPR cables identification shall be printed on outer sheath.

All cables shall meet the fire resistance requirement as per Category-B of IEC- 332 Part-3.

Allowable tolerances on the overall diameter of the cables shall be ± 2 mm maximum over the declared value in the technical data sheets.

In plant repairs to the cables shall not be accepted. Pimples, fish eye, blow holes etc. are not acceptable.

Cable selection & sizing

Control cables shall be sized based on the following considerations:

- (a) The minimum conductor cross-section shall be 1.5 sq.mm.
- (b) The minimum number of spare cores in control cables shall be as follows:

No. of cores in cable	Min. No. of spare cores
2C, 3C	NIL
5C	1
7C-12C	2
14C & above	3

Cable lengths shall be considered in such a way that straight through cable joints are avoided.

All Cables shall be of armoured type.

TYPE TESTS

The reports for the following type tests shall be submitted for one size of control cables. Size shall be decided by the employer during detailed engineering

S. No.	Type Test	Remarks
	For Conductor	
1.	Resistance test	
	For Armour Wires / Formed Wires (If applicable)	
2.	Measurement of Dimensions	
3.	Tensile Test	
4.	Elongation test	
5.	Torsion test	For round wire only
6.	Wrapping test	For aluminium wires / formed wires only.
7.	Resistance test	
8(a).	Mass of zinc Coating test	For GS wires/formed wires only
8(b).	Uniformity of zinc coating	For GS wires/formed wires only
9.	Adhesion test	For GS wires/formed wires only
	For PVC insulation & PVC Sheath	

S. No.	Type Test	Remarks
10.	Test for thickness	
11.	Tensile strength and elongation test	before ageing and after ageing
12.	Ageing in air oven	
13.	Loss of mass test	For PVC insulation and sheath only
14.	Hot deformation test	For PVC insulation and sheath only
15.	Heat shock test	For PVC insulation and sheath only
16.	Shrinkage test	
17.	Thermal stability test	For PVC insulation and sheath only
18.	Oxygen index test	For outer sheath only
19.	Smoke density test	For outer sheath only
20.	Acid gas generation test	For outer sheath only
	For completed cables	
21.	Insulation resistance test(Volume resistivity method)	
22.	High voltage test	
23.	Flammability test as per IEC-332 Part-3 (Category-B)	

INSTRUMENTATION CABLE INTERCONNECTION AND TERMINATION PHILOSOPHY

The cable interconnection philosophy to be adopted shall be such that extensive grouping of signals by large scale use of field mounted Group Junction Boxes (JBs) at strategic locations (where large concentration of signals are available, e.g. valves limit & torque switches, switchgear) is done and consequently cable with higher number of pairs are extensively used. The details of termination to be followed are mentioned in the given Table A.

TABLE A: CABLE TERMINATION TO BE FOLLOWED

Application		Type Of Termination		Type Of Cable
FROM (A)	TO (B)	END A	END B	
Valves/dampers drives (Integral Junction box)	Marshalling / Marshalling – cum Termination Cubicle / local group JB	Plug in connector	Post mount cage clamp type.	G
Transmitters, Process Actuated switches mounted in LIE/LIR	Integral Junction box of LIE/LIR	Plug in connector	Cage clamp (Rail mount) type.	F,G
RTD heads	Local junction box	Plug in connector	Cage clamp (Rail mount) type.	F
Thermocouple	Local junction box / CJC box (if applicable)	Plug in connector	Cage clamp (Rail mount) type.	A, B, C*
Other Field mounted Instrument	Local JB / Group JB	Plug in connector	Cage clamp (Rail mount) type.	F,G
RTD	Temperature transmitter	Plug in connector	Screwed, Cage clamp type	F
Thermocouple	Temperature transmitter	Plug in connector	Screwed, Cage clamp type	A, B, C*
Local Junction box, Temperature Transmitter, Int. Junction box of LIE/ LIR/ MCC/SWGR	Group JB	Cage clamp (Rail mount) type.	Cage clamp (Rail mount) type.	F,G
Local Junction box, Temperature Transmitter, Int. Junction box of LIE/ LIR/ Group JB / MCC/SWGR	Marshalling / Marshalling – cum Termination Cubicle	Cage clamp (Rail mount) type.	Cage clamp (Post mounted) type.	F,G
Marshalling cubicle/ Termination Cabinet	Electronic system cabinet	Cage clamp (Post mounted) type.	Plug-in connector / other system as per Mfr.'s Standard	Internal wiring

Application		Type Of Termination		Type Of Cable
FROM (A)	TO (B)	END A	END B	
Marshalling/ Termination System Cabinets	UCD mounted equipments	Cage clamp (Post mounted) type.	Plug in connector / Cage clamp type (rail mounted).	F,G (with plug-in connect or at one end)
DDCMIS/PLC cabinets	PC, Printers etc.	Plug in connector	Plug in connector	Mfr.'s Standar d

Notes:

1. Normally 10% spare cores shall be provided when the numbers of pairs of cables are more than four pairs, except for pre-fabricated cables which shall be as per manufacturer's standard.
2. For analog signals, individual pair shielding & overall shielding & for Binary signals, only overall shielding of instrumentation cables shall be provided.
3. * For high temperature applications only.
4. For connection between field/JB and DDCMIS marshalling cabinet Minimum 4 pair instrumentation cable shall be used.
5. All the spare cores of instrumentation cable have to be terminated in Marshalling cabinets/ DCS panel end.
6. Not used.

TERMINAL BLOCKS:

Terminal blocks shall be rail mounted/post mounted, cage clamp type with high quality non-flammable insulating material of melamine suitable for working temperature of 105 deg.

The terminal blocks in field mounted junction boxes, temperature transmitters, instrument enclosures/racks, etc., shall be suitable for cage clamp connections. The terminal blocks in Control Equipment Room logic/termination/marshalling cubicles shall be suitable for post mounted cage clamp connection at the field input end. The exact type of terminal blocks to be provided by the Bidder and the technical details of the same including width etc. shall be subject to Employer's approval.

All the terminal blocks shall be provided complete with all required accessories including assembly rail, locking pin and section, end brackets, partitions, small partitions, transparent covers, support brackets, distance sleeves, warning label, marking, etc.

The marking on terminal strips shall correspond to the terminal numbering on wiring diagrams. At least 20% spare unused terminals shall be provided everywhere including local junction boxes, instrument racks/enclosures, termination/marshalling cabinets, etc. All terminal blocks shall be numbered for identification and grouped according to the function.

Engraved labels shall be provided on the terminal blocks.

The terminal blocks shall be arranged with at least 100 mm clearance between two sets of terminal blocks and between terminal blocks and junction box walls.

INTERNAL PANELS/ SYSTEM CABINETS WIRING

Internal panel/cabinet wiring shall be of multi-stranded copper conductor with FRLS PVC insulation without shield and outer sheath meeting the requirements of VDE 0815.

All internal wires shall be provided with tag and identification nos. etched on tightly fitted ferrules at both ends. All wires directly connected to trip devices shall be distinguished by one additional red colour ferrule.

All external connection shall be made with one wire per termination point. Wires shall not be tapped or spliced between terminal points.

All floor slots of desk/panels/cabinets used for cable entrance shall be provided with removable gasketed gland plates and sealing material. Split type grommets shall be used for prefabricated cables.

All the special tools as may be required for solder less connections shall be provided by Bidder.

Wire sizes to be utilised for internal wiring.

(i) Current (4-20 mA), low voltage signals (48V);
Ammeter/Voltmeter circuit, control switches etc.
for electrical system.

0.5 Sq.mm.

(ii) Power supply and internal illumination.

2.5Sq.mm. minimum (shall be as per load requirement).

INSTRUMENTATION CABLE INSTALLATION AND ROUTING

All cables assigned to a particular duct/conduit shall be grouped and pulled in simultaneously using cable grips and suitable lubricants. Cables removed from one duct/conduit shall not be reused without approval of Employer.

Cables shall be segregated as per IEEE Std.-422. In vertically stacked trays, the higher voltage cable shall be in higher position and instrumentation cable shall be in bottom tier of the tray stack. The distance between instrumentation cables and those of other system shall be as follows:

From 11 kV/6.6 kV/3.3 kV tray system	- 914 mm
From 415V tray system	- 610 mm
From control cable tray system	- 305 mm

Cables shall terminate in the enclosure through cable glands. All cable glands shall be properly gasketed. Sealing (to prevent ingress of dust entry and propagation of fire) shall be provided for all floor slots used for cable entrance. Compression cable glands (double for armoured and single for other cables) shall be provided.

The cables emanating from redundant equipment/devices shall be routed through different paths. The above segregation of cables & wiring for redundant equipment's/devices shall be in accordance with IEEE-Std-422.

CABLE LAYING AND ACCESSORIES

CABLE LAYING

1 Cables shall be laid strictly in line with cable schedule.

2 Identification tags for cables.

Indelible tags to be provided at all terminations, on both sides of wall or floor crossing, on each conduit/duct/pipe entry/exit, and at every 20 m in cable trench/tray.

3 Cable tray numbering and marking.

To be provided at every 10m and at each end of cable way & branch connection.

4 No jointing is permissible for Instrumentation cables. For other cables jointing for more than 250 Meters run of cable shall be permitted.

5 Buried cable protection

With concrete slabs; Route markers at every 20 Meters along the route & at every bend.



6 Segregation (physical isolation to prevent fire jumping)

All cable associated with the unit shall be segregated from cables of other Units.

Interplant cables of station auxiliaries and unit critical drives shall be segregated in such a way that not more than half of the drives are lost in case of single incident of fire.

7 Cable clamping

All cables laid on trays shall be neatly dressed up & suitably clamped/tied to the tray. For cables in trefoil formation, trefoil clamps shall be provided.

 BHARAT HEAVY ELECTRICALS LTD	PROJECT: 1x800 MW TSGENCO Kothagudem FGD	 TELANGANA STATE POWER GENERATION CORPORATION LTD
BHEL DOC.NO. – HY-WBM-KTPS-DS-0	<u>Equipment Sizing Report</u>	Page 2 of 10
TSGENCO Doc. No. – HY-WBM-KTPS-DS-0		

1. INTRODUCTION

The Limestone grinding and slurry preparation system, which consists of wet ball mill circuit for limestone slurry preparation purpose, is a part of FGD (Flue Gas Desulphurisation) plant. The power plant uses coal as the fuel to generate power. The combustion reaction (burning of the coal) process produces flue gas, which typically releases Sulphur dioxide in the atmosphere. FGD system is designed to reduce the amount of Sulphur dioxide in the flue gas prior to discharge it to atmosphere and limestone slurry is used as the reagent for the same.



2. PROJECT INFORMATION

Owner	:	TELANGANA STATE POWER GENERATION CORPORATION LTD
Contractor	:	BHEL
Project/Product	:	1x800 MW TSGENCO Kothagudem FGD
Ambient temperature (Min.)	:	27°C
Ambient temperature (Design)	:	45°C
Ambient Relative Humidity	:	60%

3. EQUIPMENT INFORMATION

Below indicated are the main components of the limestone grinding / slurry preparation System.

- 1) Wet Ball Mill.
- 2) Weigh Feeder.
- 3) Gates (Rod, Knife, Flap).
- 4) Mill Slurry Tank with Agitator.
- 5) Slurry Pumps.
- 6) Hydro-Cyclone.
- 7) Piping and Valves.
- 8) Chutes

	BHARAT HEAVY ELECTRICALS LTD	PROJECT: 1x800 MW TSGENCO Kothagudem FGD		TELANGANA STATE POWER GENERATION CORPORATION LTD
BHEL DOC.NO. – HY-WBM-KTPS-DS-0		<u>Equipment Sizing Report</u>		Page 3 of 10
TSGENCO Doc. No. – HY-WBM-KTPS-DS-0				

4. EQUIPMENT SIZING AND SELECTION DATA

4.1 Wet Ball Mill (2 nos.)

There shall be two numbers of wet Ball mills for grinding of limestone; each mill shall be sized to meet the following conditions.

WBM Design Capacity	17.15 Tons Per Hour (TPH)
Input Limestone Size	Max. 25 mm, 100% < 25mm & 90% < 20mm.
Minimum Slurry Conc. Leaving System (at hydro cyclone overflow)	30% Solids (w/w)
Output Fineness (at hydro cyclone overflow)	90% passing through 325 mesh (44 µm).
Limestone bond index	14.3 kWh/ton (design)
pH of Limestone slurry	7 to 8.2
Chloride content in Limestone slurry	50 to 70 ppm as CaCO ₃ / 35.4 to 49.6 mg/l

An emergency auxiliary drive is provided to prevent settling /solidification of limestone when the mill is out of operation and also for maintenance purpose.

All parts of the mill including mill body, trunnion, hydro-cyclones, integral pipes, mill circuit pumps and other parts in contact with limestone slurry is provided with replaceable rubber wear liners.

Facility shall be provided for on-load loading of steel balls to the mill.

The material of the balls shall be chosen to ensure that the balls do not lose their original shape and to ensure minimum ball consumption.

Project Name :ENQ/ NIT No: _____(Vendor to fill & submit along with offer)

LIST OF DEVIATIONS/ EXCEPTIONS (IF ANY, vendor to fill and submit along with offer)

Sl No	Clause No	Page No	Description of Deviation

Note: Enlarge the table to incorporate items

SIGNATURE OF BIDDER -----

NAME -----

DESIGNATION -----

INDICATIVE VENDOR LIST

FLUE GAS DESULPHURISATION (FGD) SYSTEM PACKAGE

**TECHNICAL SPECIFICATION
SECTION-VI**

Disclaimer for Indicative Vendor List

- 1.1 Reasonable efforts have been made to collate the sub-vendors proposed by the various main contractors from time to time against different Projects/Packages and accepted by NTPC for various items. However, in case of error/omission, if any, and represented by the successful bidder this will be addressed during the execution of the contract based on the material evidence available with NTPC / Main Contractor.
- 1.2 The approved sub-vendor list drawn is not based on NTPC driven enlistment process but based on the sub- vendors proposed by various Main Contractors. As such, it is possible that some of the Suppliers/Manufacturers who may be involved in similar work/process may not be appearing in the list as such sub-vendors may not have been proposed by Main Contractors against NTPC Contracts.
- 1.3 In case the successful bidder chooses to propose additional sub-vendors with relevant experience after the award of the contract such sub-vendors will be considered in terms of Clause no: 19.1 of GCC, provided the proposals are received sufficiently in time: 90 days prior to ordering date of a Bought Out Items/Start of Manufacturing so as not to impede the progress of the contract.
- 1.4 Sub-vendors have been grouped under different categories of items. It is possible that an item characterized by certain specific features such as range and type required as per Main Contractor's design requirements may not be in the range of the listed sub-vendor's manufacturing process/capability. As such the main contractor to ascertain the vendor's capability to meet his specific requirements before considering a sub-vendor.
- 1.5 It is to be noted by the bidders that any shortfall in contract performance attributable to the sub-vendor listed will not absolve the contractor from his contractual obligations in any manner.

- 1.6 The approval was granted based on the evaluation of relevant capabilities and facilities possessed by the sub-vendor at the time of evaluation. Also, some of the sub-vendors may not be active. As such, the successful bidder is to carry out his own due diligence before considering the listed sub-vendor for subletting: the current status of the sub-vendor, the continued availability of productive resources including Human Resources.
- 1.7 The list of sub-vendors is periodically revised to include new sub-vendors. Such a revision may also see a deletion of certain sub-vendors who may have been disqualified on grounds of inadequate performance or banned in line with NTPC's banning policy. The then current list will be shared with the successful bidder immediately on award.

Project : Package : EGD Package Supplier : Contract No.:		MECHANICAL ITEMS- INDICATIVE SUB-VENDOR LIST LIST OF ITEMS REQUIRING QUALITY PLAN AND SUB-SUPPLIER APPROVAL					Doc No Rev No Date Page		
Sl No	ITEM	QP/ Insp. Cat.	QP No:	QP Sub, approval Sch.	Proposed sub-supplier	Place	Sub- Supplier approval status / category	Sub- supplier Details submission sch	Remark
1	Slurry re-circulation Pumps				Indiana Conveyors Pvt.Ltd., Quality Engineering Works	Jejuri, Pune Kokalla	A A		Refer Sub-QR List Refer Sub-QR List
2	Oxidation Blowers				Main Contractor Approved Sub.vendors				
3	Wet Limestone Grinding Mill				Jindal	Ghaziabad	A		
4	Slurry Pumps				TATA STEEL	Jamshedpur	A		
5	Agitators				SAIL	Rourkela	A		
6	Vacuum Belt Filters				Surya Roshni	Bahadurgarh	A		
7	Booster Fan				Welspan	Anjar	A		
8	Bucket Elevator				MSJ	Raigarh	A		
9	Absorber tank				Gujarat Infra	Vadodara	A		
10	Atmospheric Tanks / Air Receiver Tanks				Indus Tube	G. B. Nagar	A		
11	Spiral welded upto 1600 mm.				Jindal Industries APL Apollo	Hissar Sikandrabad	A A		
					Babu Pipes	Sikandrabad	A		
					ESMT	Ahmedabad	A		
					Ratnamani	Anjar / Chattral	A		
					JCO Gas Pipes	Chindwara	A		
					SAIL	Rourkela	A		
					Surya Global	Kutch	A		

INDICATIVE

QUALITY PLAN

APPROVAL

PACKAGE:		INDICATIVE SUB VENDOR LIST				NTPC DOC NO
Sl No.	Item	QP/ Insp. Cat.	ACCEPTABLE SUPPLIER AS PER DATABASE	PLACE OF MANUFACTURING	APPROVAL STATUS	REVISION NO
					DATE	REMARKS
1	APRON FEEDER WITH DRIBBLE CONVEYOR		TKII	HYDERABAD	A	UPTO 2400 TPH
			L&T	KANSBAHL	A	UPTO 2200 TPH
			ELECON	VV NAGAR	A	UPTO 2200 TPH
			TENOVA INDIA	CHENNAI	A	UPTO 2200 TPH
			TRF	JAMSHEDPUR	A	UPTO 2400 TPH
2	PADDLE FEEDER		MCNALLY SAYAJI	KUMARDHUBI	A	UPTO 2200 TPH
			L & T	KANCHEEPURAM	A	UPTO 2250 TPH
			ELECON	V V NAGAR	A	UP TO 1750 TPH
			FAMAK FAMUR S.A.	POLAND	A	UP TO 1750 TPH
			TKII	PUNE	A	UPTO 1950 TPH
			TRF	JAMSHEDPUR	A	UP TO 2475 TPH
			PENNSYLVANIA CRUSHER CORPORATION	USA	A	UP TO 1760 TPH
3	RING GRANULATOR		AMERICAN PULVERISER	USA	A	UPTO 1875 TPH

NTPC		INDICATIVE SUB VENDOR LIST			NTPC DOC NO	
SI No.	Item	QP/ Insp. Cat.	ACCEPTABLE SUPPLIER AS PER DATABASE	PLACE OF MANUFACTURING	REVISION NO	
					DATE	
					APPROVAL STATUS	
					REMARKS	
			TKII	PUNE	A	<p>UP TO 2035 TPH 1. Vetting of GA drawing and QAP shall be done by TKIS -Germany. Inspection and trial run for first Ring Granulator & Vibrating Screen Feeder at TKII work's and installation and trial run at Kudgi site for first Ring Granulator & Vibrating Screen Feeder shall be done in presence of TKIS - Germany.</p> <p>2. TKIS-Germany shall submit performance back up guarantee on their letter head duly signed by authorized signatory for Ring granulator and vibrating screen feeder, in addition to performance guarantee by TKII.</p> <p>3. Spherical roller bearings and raw materials for screen plate for Ring granulator and double balance exciter units, carbon shaft, coupling between exciters and support springs for Vibrating screen feeder shall be imported from TKIS - Germany/ sources approved from TKIS - Germany.</p>
			TRF	JAMSHEDPUR	A	UP TO 1800 TPH. TRF SHALL GIVE EXTENDED WARRANTY OF 5 YEARS OVER & ABOVE CONTRACTUAL WARRANTY
			L&T	KANSBAHAL	A	UP TO 1600 TPH
			ELECON	V V NAGAR	A	UP TO 1320 TPH
			MCNALLY SAYAJI	KUMARDHUBI	A	UPTO 1000 TPH
			TECHNO VIBRAZIONI	ITALY	A	UPTO 1875 TPH
4	VIBRATING SCREEN/FEEDER		ELECON	V V NAGAR	A	UP TO 1320 TPH

INDICATIVE SUB VENDOR LIST		NTPC DOC NO
SI No.	Item	REVISION NO
PACKAGE:	QP/ Insp. Cat.	DATE
	ACCEPTABLE SUPPLIER AS PER DATABASE	APPROVAL STATUS
	PLACE OF MANUFACTURING	REMARKS
	GENERAL KINEMATICS	A
	TKII	UP TO 2000TPH
		UP TO 2035 TPH 1. Vetting of GA drawing and QAP shall be done by TKIS -Germany. Inspection and trial run for first Ring Granulator & Vibrating Screen Feeder at TKII work's and installation and trial run at Kudgi site for first Ring Granulator & Vibrating Screen Feeder shall be done in presence of TKIS - Germany. 2. TKIS-Germany shall submit performance back up guarantee on their letter head duly signed by authorized signatory for Ring granulator and vibrating screen feeder, in addition to performance guarantee by TKII. 3. Spherical roller bearings and raw materials for screen plate for Ring granulator and double balance exciter units, carbon shaft, coupling between exciters and support springs for Vibrating screen feeder shall be imported from TKIS - Germany/ sources approved from TKIS - Germany.
	TRF	A
	MONALLY SAYAJI	UP TO 1800 TPH. TRF SHALL GIVE EXTENDED WARRANTY OF 5 YEARS OVER & ABOVE CONTRACTUAL WARRANTY
	BENGAL TOOLS	A
	TKII	UP TO 1210 TPH
	ELECON	A
5	TRAVELLING TRIPPER	

SI No.		Item	PACKAGE:	INDICATIVE SUB VENDOR LIST			NTPC DOC NO
QP/ Insp. Cat.		ACCEPTABLE SUPPLIER AS PER DATABASE	PLACE OF MANUFACTURING	REVISION NO	DATE	APPROVAL STATUS	REMARKS
		MBE				A	
		TRF				A	
		INDIANA CONVEYOR				A	FOR UP TO 50 TPH RATING LIME HANDLING / GYPSUM HANDLING PLANT.
		HMTC				A	
		L & T - MACNIL				A	
		L & T				A	
		L & T - EWL				A	
6		FABRIC BELTING(FR GRADE)				A	UPTO 2200 MM WIDTH
		PHOENIX CONVEYOR BELT				A	UPTO 2400 MM WIDTH
		IMASS S.A				A	UPTO 1600 MM WIDTH
		MRF				A	UPTO 1600 MM WIDTH
		SEMPELTRAN NIRON				A	UPTO 1600 MM WIDTH
		HINDUSTAN RUBBER				A	UPTO 1600 MM WIDTH
		NORTHLAND RUBBER				A	UPTO 2200 MM WIDTH.
		SOMI CONVEYOR				A	UPTO 2000 MM WIDTH
		RAVASCO TRANSMISSION LTD.				A	UPTO 2200 MM WIDTH
		ORIENTAL RUBBER				A	UPTO 2200 MM WIDTH
		FORECH				A	UPTO 2000 MM WIDTH
		YOKOHAMA				A	UPTO 2400 MM WIDTH
		PHOENIX CONVEYOR BELT				A	UPTO 2400 MM WIDTH
		YOKOHAMA				A	UPTO 2400 MM WIDTH
		IMASS S.A				A	UPTO 2400 MM WIDTH
		FORECH				A	UPTO 2000 MM WIDTH
		CAMOPLAST				A	UPTO 2400 MM WIDTH
		ELECON				A	UPTO 2400 MM WIDTH
8		IDLERS				A	

Sl No.	PACKAGE:	Item	INDICATIVE SUB VENDOR LIST		NTPC DOC NO		
			QP/ Insp. Cat.	ACCEPTABLE SUPPLIER AS PER DATABASE		PLACE OF MANUFACTURING	REVISION NO
					DATE	APPROVAL STATUS	REMARKS
9		PIPES FOR IDLERS IS 9285		MBE	KUMARDHUBI	A	
10		BEARINGS FOR IDLERS		KALI	KUMBAKONAM	A	
11		PULLEYS		AMPS	JAMSHEDPUR	A	
				A.ADAK	HOWRAH	A	
				BENGAL TOOLS	KOLKATA	A	
				V V N MFG	V V NAGAR	A	Upto 150 NB Dia
				TKII	HYDERABAD / PUNE	A	
				PROMAC	BANGALORE	A	
				L & T - EWL	KANCHEEPURAM	A	
				ROLLWELL	HINDUPUR	A	
				INDIANA CONVEYORS	PUNE	A	
				MAIN CONT. APPRD SOURCES	HOSUR	N	SUBJECT TO VALID BIS LICENCE
				MAIN CONT. APPRD SOURCES	V V NAGAR	A	
				ELECON	BANGALORE	A	
				PROMAC	KUMARDHUBI	A	
				MBE	KOLKATA	A	
				BENGAL TOOLS	CHENNAI	A	
				TNS HEAVY	CHENNAI	A	
				KALI	THIRUBUVANAM	A	
				TKII	HYDERABAD / PUNE	A	
				L & T - EWL	KANCHEEPURAM	A	
				V V N MFG	V V NAGAR	A	Upto 800 NB Dia
				R K INDUSTRIES	NEW DELHI	A	UP TO 800 MM DIA
				ROLLWELL	HINDUPUR	A	
				INDIANA CONVEYORS	PUNE	A	
				RISHI INDUSTRIES	SONEPAT	A	
				WAHEGURU	KOLKATA	A	
				SUDEEP RUBBER	V V NAGAR	A	
				DEBIP RUBBER	KOLKATA	A	
				CORI RUBBER	CHENNAI	A	
				PRADEEP RUBBER	CHAKULA	A	
				PRESIDENCY RUBBER	KOLKATA	A	
				THEJO ENGG	CHENNAI	A	
				CENTURY RUBBER	KOLKATA	A	
13		BEARING FOR PULLEYS		MAIN CONT. APPRD SOURCES	COIMBATORE	A	Upto size 560
14		HELICAL GEARBOX		SHANTI GEARS	V V NAGAR	A	
				ELECON	KHARAGPUR	A	
				SIEMENS (FLENDER)	PUNE/FALTA	A	Up to size 710 / 450
				PREMIUM TRANSMISSION LTD		A	

PACKAGE:		INDICATIVE SUB VENDOR LIST			NTPC DOC NO	
Sl No.	Item	QP/ Insp. Cat.	ACCEPTABLE SUPPLIER AS PER DATABASE	PLACE OF MANUFACTURING	REVISION NO	
					DATE	
					APPROVAL STATUS	
					REMARKS	
15	PLANETARY GEARBOX		SIEMENS (FLENDER) NEW ALLENBURY WORKS ELECON SIEMENS (FLENDER) MOVENTAS BREVINI SEW EURODRIVE GMBH & CO.	GERMANY KOLKATA V V NAGAR GERMANY GERMANY ITALY GERMANY	A A A A A A A	
16	FLUID COUPLING (SCOOP AND TRACTION TYPE)		FLUIDOMAT PTL ELECON	DEWAS AURANGABAD V V NAGAR	A A A	Scoop type upto SC-1330 SCOOP TYPE UPTO PST 1:150 Scoop type upto model ESC 760.
17	GEARED COUPLING		VOITH MAIN CONTRACTOR APPROVED SOURCES	HYDERABAD	A	SCOOP TYPE UPTO SVNL 1330
18	FLEXIBLE COUPLINGS		MAIN CONTRACTOR APPROVED SOURCES			
19	FLAP GATE, R&P GATE AND ROD GATE*		TKI MINING & MATERIAL HANDLING UNITED-TECHNOMAC MBE PREREC HMTG ELECON	PUNE KOLKATA PUNE KUMARDHUBI HOWRAH KOLKATA V V NAGAR	A A A A A A A	
20	VENTILATION SYSTEM		MAIN CONTRACTOR APPROVED SOURCES			FAN FROM NTPC APPROVED SOURCES
21	VENTILATION FANS		MARATHON ELECTRIC MOTOR(I) LTD DUVENT S K SYSTEM ALMONARD TCF NADI HOWDEN SOLYVENT	KOLKATA BANGALORE SONIPAT CHENNAI CHENNAI CHENNAI	A A A A A A	

Sl No.	Item	PACKAGE:	INDICATIVE SUB VENDOR LIST			NTPC DOC NO	
			QP/ Insp. Cat.	ACCEPTABLE SUPPLIER AS PER DATABASE	PLACE OF MANUFACTURING		REVISION NO
							DATE
			WEIR BDK	HUBLI		Conventional CCS Gate / Globe / Check Valves up to 600MM and Class # 1500, CSS Gate/ Globe/ Check Valves up to 200MM and Class # 600, up to 500MM and class #300 , FCS Gate / Globe / Check Valves up to 50MM and Class # 2500.	
26	CS/ FS GATE/GLOBE/CHECK VALVES(MAIN CONTRACTOR APPROVED SOURCE UP TO CLASS 300 & SIZE 600 NB)		LEADER OSWAL INDUSTRIES FOURESS FOURESS	JALANDHAR AHMEDABAD AURANGABAD THANE	A A A A	CS GATE 600MM CLASS#600, SS GLOBE ONLY FOR CCS VALVES UPTO 300 NB CS 600 NB CL 150, 300 NB CLASS 300, 400NB CLASS 600 AND 150NB CLASS 600.	
			BHEL IVP	GOINDWAL	A	GATE UP TO 600NB CLASS 150, 500 NB CLASS 300, 300 NB CLASS 600, GLOBE 250 NB CLASS 400, CHECK 500 NB CLASS 150, 300 CLASS 300, 150NB CLASS 600.	
			HITECH ENGG PVT LTD.	AHEMDABAD	A	250 NB CLASS 150, 50 NB CLASS 800.	
			STEEL STRONG	RABALE	A	GATE VALVE- CS UPTO 600NB, SS UPTO 300NB; GLOBE VALVE- CS/SS UPTO 300NB; CHECK VALVE- CS UPTO 600NB, SS UPTO 250NB	
			KSB PUMPS LTD	COIMBATORE	A	300NB CLASS 2500.	
			HAWA ENGINEERS	AHMEDABAD	A	CS UPTO 450NB, CLASS #300, 500NB CLASS 150 AND SS 300NB CLASS 300, FCS / FSS 50 NB CLASS 800.	
			NITON VALVES INDIA PVT LTD	NAVI MUMBAI / AURANGABAD	A	CS GATE 900 NB CLASS 600, GLOBE 400 CLASS 300, CHECK 300 NB CLASS 600.	
			L&T VALVES LIMITED	COIMBATORE	A	650 MM CLASS 600, 50 NB CLASS 800.	
			WEIR BDK	HUBLI	A	Conventional CCS Gate / Globe / Check Valves up to 600MM and Class # 1500, CSS Gate/ Globe/ Check Valves up to 200MM and Class # 600, up to 500MM and class #300 , FCS Gate / Globe / Check Valves up to 50MM and Class # 2500.	

PACKAGE:		INDICATIVE SUB VENDOR LIST			NTPC DOC NO	
Sl No.	Item	QP/ Insp. Cat.	ACCEPTABLE SUPPLIER AS PER DATABASE	PLACE OF MANUFACTURING	REVISION NO	
					DATE	
					APPROVAL STATUS	
					REMARKS	
27	BALL VALVES (MAIN CONTRACTOR APPROVED SOURCE UP TO CLASS 800 AND SIZE 100 NB)		WEIR BDK	HUBLI	A	SS Ball valves up to 500MM and class #600, CS Ball Valves up to 250 MM and class# 900, CS/ SS Ball valves up to 100 MM and class # 1500.
			MICRO FINISH VALVES PVT. LTD.	HUBLI	A	400NB CLASS#600 AND UP TO 600NB CLASS#300
			FLOW CHEM INDUSTRIES	KALOL	A	100NB CLASS#600,200NB CLASS#300, 50 NB CLASS#800
			BRAY CONTROLS (ZHEJIANG) CO. LTD	CHINA	A	UP TO 100 NB CLASS#300
			L&T VALVES LIMITED	COIMBATORE	A	UPTO 150NB, CLASS #150/300, AND UPTO 50NB, CLASS #800
			PRECISION ENGG CO VALVES PVT LTD	MASIK	A	FCS UP TO 50NB CLASS 800, CCS UP TO 400NB CLASS 150.
			BELGAUM AQUA VALVE PVT LTD	BELGAON	A	FCS UP TO 50NB CLASS 800, CCS UP TO 200NB CLASS 150.
			G M ENGINEERING PRIVATE LTD	RAJKOT	A	UP TO 400 NB AND CLASS #600
			HAWA ENGINEERS	AHMEDABAD	A	UPTO 100NB, CLASS #150
			LEADER ENGG	JULLUNDHAR	A	
			BOMBAY METAL	MUMBAI	A	
			SANT VALVES	JULLUNDHAR	A	
			TRACTEL TRFOR	PALWAL	A	UPTO 20 TON
			LIFTING EQUIPMENT	DELHI	A	UPTO 12 TON
			ARMS&S	BANGALORE	A	UPTO 5 TON
			CENTURY CRANE ENGINEERS PVT. LTD	BALLABHGARH	A	UPTO 7.5 TON
			HERCULES HOIST	RAIGAD	A	UPTO 15 TON
			REVA INDUSTRIES	FARIDABAD	A	
			EDDY CRANE	PUNE	A	UPTO 10 TON
			CONSOLIDATED HOIST	SATARA /PUNE *	A	*PUNE FOR ELECTRIC HOIST UPTO 15 TONS
			ELECTROTHERAPHY	RISHRA	A	UPTO 15 TON FOR ELECTRIC HOIST ONLY
			HERCULES HOIST	RAIGAD	A	UPTO 15 TON FOR ELECTRIC HOIST ONLY
			TUBRO FERGUSSON	KOLKATA	A	UPTO 5 TON FOR ELECTRIC HOIST
			PRAYAS ENGG (PBL)	V V NAGAR	A	UPTO 10 TON FOR ELECTRIC HOIST ONLY

Sl No.	Item	PACKAGE:	INDICATIVE SUB VENDOR LIST		NTPC DOC NO		
			QP/ Insp. Cat.	ACCEPTABLE SUPPLIER AS PER DATABASE		PLACE OF MANUFACTURING	REVISION NO
							DATE
			ALPHA SERVICES	ALWAR	A	SINGLE GIRDER EOT CRANE & ELECTRIC HOIST UPTO 15 TON ONLY. GEARBOX FROM NTPC APPROVED SOURCES FOR EOT CRANE.	
			CENTURY CRANE ENGINEERS PVT. LTD	BALLABHGARH	A		
			ARMSEL	BANGALORE	A	UPTO 10 TON EOT & UPTO 15 T ELECTRIC HOIST	
			TRACTEL TIRFOR	PALWAL	A	UPTO 15 TON FOR ELECTRIC HOIST AND UPTO 10 TON FOR EOT	
			MILLARS INDIA	KARANSAR	A		
			AVON CRANES	GURGAON	A		
			GRIP ENGINEERS	HYDRABAD	A	GEARBOX FROM NTPC APPROVED SOURCES FOR EOT CRANE.	
			GRIP ENGINEERS	FARIDABAD	A	UPTO 20 TON ELECTRIC HOIST ONLY	
			INDIAN FORGING AND STAMPING	JAMSHEDPUR	A		
			HINDUSTAN FORGE	MUMBAI	A		
			BAY FORGE	CHENNAI	A		
			VIKRANT FORGINGS	KOLKATA	A		
			SAIL	DURGAPUR	A		
			BHARAT FORGE	PUNE	A		
			TAYO ROLLS	JAMSHEDPUR	A		
			PUNJAB HAMMER	MANDI GOVINDGARH	A		
			FORGING INDIA	KOLKATA	A		
			PAHLAD RAT FORGINGS	KANPUR	A		
			HEC	RANCHI	A		
			VISHNU FORGINGS	NASIK	A		
			PRAYAS CASTINGS	VV NAGAR	A		
			STEELCAST	BHAVNAGAR	A		
			KOLHAPUR STEEL	KOLHAPUR	A		
			AQUA ALLOYS	KOLHAPUR	A		
			MARTOPEARL ALLOYS	HYDERABAD	A		
			UP STEEL	MUZAFFAR NAGAR	A	NOT FOR Mn STEEL CASTING	
			GS ALLOYS	VIJAYWADA	A	NOT FOR Mn STEEL CASTING	
			VOSSLOH BEEKAY CASTINGS	BHILAI	A	UPTO 250 KG. NOT FOR Mn STEEL CASTING	
			RAIPUR CASTINGS	BILASPUR	A	UPTO 250 KG.	
31	ALLOY STEEL/CARBON STEEL FORGINGS						
32	CS AND ALLOY STEEL CASTINGS						

NTPC		INDICATIVE SUB VENDOR LIST		NTPC DOC NO	
SI No.	Item	QP/ Insp. Cat.	ACCEPTABLE SUPPLIER AS PER DATABASE	REVISION NO	
			PLACE OF MANUFACTURING	DATE	
				APPROVAL STATUS	
				REMARKS	
33	MISC. FABRICATED ITEMS, TECHNOLOGICAL STRUCTURE		MAIN CONTRACTOR APPROVED SOURCES		PHYSICAL ASSESSMENT SHALL BE DONE BY THE MAIN CONTRACTOR BASED ON CRITERIA/CHECKLIST PROVIDED BY NTPC
34	BELT CLEANER & SKIRT BOARD SEALING (BACKING PLATE, RUBBER BLOCKS), FESTOON TROLLEY		MAIN CONT. APPROVED SOURCES		
35	SCRAPPER,SHEAVES,TAKEUP TROLLEY,TAKEUP COMPONENTS (THIMBLE,BULL DOG GRIP,TURN BUCKLE,COUNTER WEIGHTS), SCREW TAKEUP, RAIL, MANUAL RAIL CLAMP		MAIN CONTRACTOR APPRD SOURCES		
36	WIRE ROPE		BOMBAY WIRE ROPES	MUMBAI	A
			BHARAT WIRE ROPE	MUMBAI	A
			USHA MARTIN	RANCHI	A
37	PAC		VOLTAS	THANE/SILVASSA	A
			CARRIER AIRCON	GURGAON	A
			BLUESTAR	SILVASSA	A
38	SPLITWINDOW AC		MAIN CONTRACTOR APPRD SOURCES		
39	QUICK RELEASE COUPLING, SHRINK DISC COUPLINGS, SLIP RING , CLUTCH COUPLING, COMPRESSION COUPLINGS		MAIN CONTRACTOR APPRD SOURCES		
40	AIR RELEASE VALVE, FLOAT VALVES		MAIN CONTRACTOR APPRD SOURCES		
41	DUST SUPPRESSION SYSTEM (PLAIN WATER & DRY FOG)		MAIN CONTRACTOR APPRD SOURCES		BOIs (Pump,Strainer,Pipes, Nozzle, Gate,Globe,Check valve, Butterfly valve, Actuator,Motors,Control Panel, Pressure Reducing valve ,Solenoid valve, Pressure Gauge and Temperature Gauge, Pressure switch, Level switch, Flow switch, Transmitter) from NTPC approved sources
42	BELT VULCANISER		NILOS	CHENNAI	A
			THEJO ENGG	CHENNAI	A
43	CAST IRON CASTING		MAIN CONT. APPRD SOURCES		
44	PLUMMER BLOCK		MAIN CONT. APPRD SOURCES		

PACKAGE:		INDICATIVE SUB VENDOR LIST				NTPC DOC NO
Sl No.	Item	QP/ Insp. Cat.	ACCEPTABLE SUPPLIER AS PER DATABASE	PLACE OF MANUFACTURING	APPROVAL STATUS	REMARKS
45	SAFETY RELIEF VALVE		LEADER SPIRAX MARSHALL FISHER SANMAR	JULLANDHAR PUNE CHENNAI	A A A	
46	STRAINERS		MAIN CONTRACTOR APPRD SOURCES			
47	BUTTER FLY VALVE (MAIN CONTRACTOR APPROVED SOURCE UP TO CLASS 150 & SIZE 600 NB)		INTERVALVE POONAWALA LTD WEIR BDK PENTAIR VALVES CRANE FLOW PROCESS FLOWSERVE INDIA CONTROLS FOURES S ENGINEERING (INDIA) LIMITED KBL R & D MULTIPLE ADVANCE	PUNE HUBLI HALOL SATARA CHENNAI BANGALORE KONDHAPURI VALSAD GAGRET	A A A A A A A	SGI / CI / D2 1400MM PN10, SGI / CI 1000MM PN16, CS/SS 500MM PN16, SS 400MM CLASS#300, UPTO 2800NB, PN 6 CI / DI butterfly valve up to 1000MM and PN16 AND up to 1800MM and PN10, CCS UP TO 1050MM CLASS 150 AND up to 1800MM and PN16 SS - UP TO 400NB PN-16 , FABRICATED 800MM CLASS#150. FOR SS UP TO 500 NB PN-10, CI- UP TO 900NB PN-10, UP TO 500NB PN-16, 450MM CLASS#300., UPTO 2800NB, PN6. CI & SS UPTO 500 NB PN16, 600 NB PN10 UPTO 600 NB, CI ONLY PN 16/ CLASS 150 CAST SGI/CI/ MS FABRICATED- UP TO 1200 PN-10, UP TO 350 PN-16 ,2400 MM PN6/CLASS150 SS - UP TO 300NB PN-10, UPTO 2700NB CLASS # 75 CAST SGI/CI/CS 1400 MM PN16 , SS 300 MM PN16 , 1800MM CLASS 150, MS FABRICATED 900 NB PN40,2800NB, PNG. CAST SGI/CI/MS FABRICATED- UP TO 1800 MM PN-10/CLASS # 75 , 1100MM PN25,1400MM CLASS#150 , UPTO 2800NB CLASS # 75 SOFT SEATED, CONCENTRIC BFV OF CI/ CS/ SS OF SIZE UPTO 250MM AND PRESSURE RATING UPTO CLASS #150.

PACKAGE:		INDICATIVE SUB VENDOR LIST			NTPC DOC NO	
Sl No.	Item	QP/ Insp. Cat.	ACCEPTABLE SUPPLIER AS PER DATABASE	PLACE OF MANUFACTURING	REVISION NO	
					DATE	
					APPROVAL STATUS	
					REMARKS	
			ADVANCE	GREATER NOIDA	A	METAL SEATED, TRIPLE ECCENTRIC, SS BFV OF SIZE UPTO 100NB, AND PRESSURE RATING UPTO CLASS #300.
			BRAY CONTROLS INDIA PVT LTD	VADODARA	A	UP TO 400NB CLASS 150 / PN16
			BRAY CONTROLS (ZHEJIANG) CO. LTD	CHINA	A	UP TO 400 NB CLASS#600
			L&T	KANCHIPURAM	A	UPTO 400NB, CLASS #150
			INSTRUMENTATION LTD.	PALAKKAD	A	UPTO 2200NB CLASS # 75
			HAWA ENGINEERS	AIHMERABAD	A	CI/ CS & FABRICATED UPTO 1200MM, CLASS #150, SS UPTO 250MM, CLASS#150
48	MS FITTINGS (BLACK / GI) AS PER IS 1239 PART-2		MAIN CONTRACTOR APPRD SOURCES			
49	MS ERW PIPES AS PER IS 1239 / IS 3589 (UPTO 600 NB)		SAIL	ROURKELA	A	
			MAHARASHTRA SEAMLESS	RAIGAD	A	200 NB TO 500 NB ERW PIPES AS PER IS 3589
			INDUS TUBES	G.B.NAGAR	A	UPTO 300 NB AS PER IS 1239/3589
			SURYA ROHINI	BAHADURGARH	A	UPTO 400 NB ERW PIPES AS PER IS 1239/3589
			JINDAL	GHAZIABAD	A	UPTO 350 NB ERW PIPES AS PER IS 1239/3589
			JINDAL	JANGALPUR	A	UPTO 500 NB FOR BLACK PIPE
			JINDAL INDUSTRIES LTD.	HISSAR	A	UP TO 300 NB ERW BLACK PIPE AS PER IS 1239/3589
			APL APOLLO TUBES LTD.	SIKANDRABAD	A	MS pipes (Black & GI) as per IS 1239 & MS pipes (Black & GI) as per IS 3589 up to 250 NB size, 8 mm thickness and Grade up to Fe 410.
			LLYODS LINE PIPES LTD.	THANE	A	MS pipes (Black & GI) as per IS 1239 & MS pipes (Black) as per IS 3589 up to 350 NB size, 8 mm thickness and Grade up to Fe 410.
			DADU PIPES	SIKANDRABAD	A	UPTO 300 NB ERW BLACK PIPES

PACKAGE:		INDICATIVE SUB VENDOR LIST			NTPC DOC NO	
Sl No.	Item	QP/ Insp. Cat.	ACCEPTABLE SUPPLIER AS PER DATABASE	PLACE OF MANUFACTURING	REVISION NO	
					DATE	
					APPROVAL STATUS	
					REMARKS	
			TATA	JAMSHEDPUR	A	UPTO 150 NB ERW PIPES AS PER IS 1239
			RATNAMANI	KUTCH	A	ERW PIPES AS PER IS 3589 UPTO 400 NB
			WELPSUN	ANJAR	A	UPTO 400 NB ERW PIPES AS PER IS 1239/3589
50	FORGED/FORMED FITTINGS		GUJARAT INFRA PIPES	BARODA	A	
			EBY	UMBAI	A	
			N.L.HAZRA	KOLKATA	A	
			MS FITTINGS	KOLKATA	A	
			TRUE FORGE	FARIDABAD	A	
			TUBE PRODUCTS	BARODA	A	
			PIPEFIT ENGINEERS	BARODA	A	
			SIDDARTH & GAUTAM	FARIDABAD	A	
51	MATERIAL FOR DUCTING, DUCTING SUPPORT, GRILLS, LOUVRE, DAMPERS, PRE & FINE FILTERS (no of filters < 100 each), EARTHING MATERIAL (MS ROUND BAR)		MAIN CONTRACTOR APPRO SOURCES			
52	CI PRESSURE RELIEF/REDUCING VALVE		DARLING MUESCO	AHMEDABAD	A	
			LEADER	JULLUNDHAR	A	
			FISCHER SANMAR	PUNE	A	
			SPIRAX MARSHALL	PUNE	A	
			FAINGER LESSER	AURANGABAD	A	
			EATON POWER	PUNE	A	
53	HYDRAULIC POWER PACK		BOSCH-REXROTH	AHMEDABAD	A	
			HAGGLUNDS	SWEDEN	A	
			MAHA HYDRAULICS	CHENNAI	A	
			L & T HYDRAULICS	BANGALORE	A	EXCEPT FOR STACKER RECLAIMER
54	HYDRAULIC CYLINDER		VELJAN	HYDERABAD	A	
			WIPRO	BANGALORE	A	
			EATON POWER	PUNE	A	
			L & T HYDRAULICS	BANGALORE	A	

PACKAGE:		INDICATIVE SUB VENDOR LIST			NTPC DOC NO
Sl No.	Item	QI/ Insp. Cat.	ACCEPTABLE SUPPLIER AS PER DATABASE	PLACE OF MANUFACTURING	REVISION NO
					DATE
					APPROVAL STATUS
					REMARKS
55	HYDRAULIC MOTOR		BOSCH-REXROTH POCLAIN HYDRAULICS HAGGLUNDS PARKER CALZONI MAHA HYDRAULICS KAWASAKI	AHMEDABAD FRANCE SWEDEN ITALY CHENNAI UK	A A A A A A
56	HYDRAULIC PIPE & PIPE FITTING		MAIN CONTRACTOR APPRD SOURCES		
57	SCREW TYPE AIR COMPRESSORS		ELGI ATLAS COPCO INGERSOL RAND INDIA KOBELCO AERZENER ELGI SWAMI	COIMBATORE BELGIUM. AHMEDABAD JAPAN GERMANY COIMBATORE NOIDA	A A A A A A A
58	BLOWER		KAY INTERNATIONAL EVEREST KULKARNI POWER TOOLS	SONEPAT NEW DELHI / BAHADURGARH SHIROL	A A A
59	PNEUMATIC CYLINDER		NUCON ROTEX	HYDERABAD MUMBAI	A A

PACKAGE:		INDICATIVE SUB VENDOR LIST			NTPC DOC NO	
Sl No.	Item	QP/ Insp. Cat.	ACCEPTABLE SUPPLIER AS PER DATABASE	PLACE OF MANUFACTURING	REVISION NO	
					DATE	
					APPROVAL STATUS	
					REMARKS	
60	REFRIGERANT TYPE DRIER		SCHRADER DUNCAN	PUNE	A	UPTO 350 NB
			VAAS INDUSTRIES	CHENNAI	A	UPTO 300 NB
			ORBINOX	COIMBATORE	A	UPTO 300 NB
			SUMMIT'S HYGRONICS	COIMBATORE	A	Upto 11893 m3/hr
			TRIDENT	COIMBATORE	A	Upto 10000 m3/hr
			MELCON	GREATER NOIDA	A	Upto 7250 m3/hr
			DELAIR	GURGAON	A	Upto 7500 m3/hr
			ATLAS COPCO	BELGIUM	A	Upto model FD 1200
61	DESSICANT TYPE AIR DRYER		DELAIR	GURGAON	A	
			INDCON	DELHI	A	
			MELCON	GREATER NOIDA	A	
			SUMMIT	COIMBATORE	A	
			TRIDENT	COIMBATORE	A	
62	AIR RECEIVER(MAIN CONTRACTOR APPROVED SOURCE FOR < 10 KSC PRESSURE)		UNITED ENGINEERS	NASHIK	A	
			TEMASME VESELEX	NOIDA	A	
			INTEGRATED ENGINEERS	MUMBAI	A	
			LABACUS HEAT TRANSFER	FARIDABAD	A	
			PARKAIRE	DELHI	A	
			GEM	COIMBATORE	A	
63	ROTARY FEEDER		INDURE	SAHIBABAD	A	
			DCIPS	KOLKATA	A	
			MELCO	FARIDABAD	A	
			MCNALLY SAYAJI	ASANSOL/KUMARDHUBI	A	
			MACAWBER BEEKAY	KESHWANA	A	
			EXPONENTIAL ENGINEERING	PUNE	A	

PACKAGE:		INDICATIVE SUB VENDOR LIST			NTPC DOC NO
Sl No.	Item	QP/ Insp. Cat.	ACCEPTABLE SUPPLIER AS PER DATABASE	PLACE OF MANUFACTURING	REVISION NO
					DATE
					APPROVAL STATUS
					REMARKS
64	PLAIN WATER SPRAY NOZZLE/SPRINKLERS FOR DS SYSTEM		SPRAYING SYSTEM	BANGALORE	A
			F.HARLEY	KOLKATA	A
			EAGLE AGRO	RAJKOT	A
			INDIANA GRATINGS PVT. LTD.	PUNE	A
			JINDAL STEEL & POWER LTD.	RAIGARH	A
			BABY ENGG. PVT. LTD.	TRICHY	A
			REGIONAL ENGG. WORKS	TRICHY	A
			AJANTHA FABS	MATHUR	A
			CAPACITE STRUCTURES LTD.	THANE	A
			MIURA INFRASTRUCTURE PVT LTD.	BHILAI	A
			SHIVAM HITECH STEELS PVT. LTD	BHILAI	A
			TECHNOFAB MANUFACTURING LTD.	CHENNAI	A
			JSW SEVERFIELD STRUCTURES LTD(JSS)	BELLARY	A
			ALLIANCE INTEGRATED METALIKS LTD(AIML)	RAJPURA	A
			ATMASTCO PVT LTD	DURGAPUR	A
			APEX BUILDSYS LTD	NAGPUR	A
			COREFAB PROJECTS PVT LTD	BHILAI	A
			KOTHARI CHEMICALS	BHILAI	A
			FEDDERS LLOYD CORPORATION LTD	SIKANDRABAD	A
			ARCELOR MITTAL DHAMM PROCESSING PVT LTD	RANIPET	A
			ARTSON ENGINEERING	NASIK	A
65	SHOP FABRICATED STRUCTURE				

PACKAGE:		INDICATIVE SUB VENDOR LIST			NTPC DOC NO	
					REVISION NO	
					DATE	
Sl No.	Item	QP/ Insp. Cat.	ACCEPTABLE SUPPLIER AS PER DATABASE	PLACE OF MANUFACTURING	APPROVAL STATUS	REMARKS
			ARTSON ENGINEERING	NAGPUR	A	

LEGENDS

1. SYSTEM SUPPLIER/SUB-SUPPLIER APPROVAL STATUS CATEGORY (SHALL BE FILLED BY NTPC)

A – For these items proposed vendor is acceptable to NTPC. To be indicated with letter "A" in the list alongwith the condition of approval, if any.

DR – For these items "Detailed required" for NTPC review. To be identified with letter "DR" in the list.

NOTED – For these items vendors are approved by Main Supplier and accepted by NTPC without specific vendor approval from NTPC. To be identified with "N"

INDICATIVE VENDOR LIST FOR NTPC

ELECTRIC ACTUATORS

GENERAL:

Actuators shall be designed for valve operation to ensure proper function in accordance with specifications given below and complying to EN15714-2 or equivalent. All standards, specifications and codes of practice referred to herein shall be the latest editions including all applicable official amendments and revisions.

This sub-section of specification is applicable for following types of electric actuators:

Modulating duty electric actuators:

These shall be provided as per standard practice of OEM of equipment, meeting other requirements of specifications. For specifications of Blade pitch actuators of this chapter.

Electric actuators for valves/ dampers/ gates (other than covered above):

These actuators shall be Non-Intrusive type electric actuators. The interface of these actuators with DDCMIS shall be of two types viz. with Hardwired interface and with Fieldbus interface. The common requirements of both these type of actuators are specified below, specific requirements of Non-Intrusive hardwired actuators are specified at below and specific requirements of Non-Intrusive fieldbus actuators are specified below.

1. COMMON REQUIREMENTS FOR NON INTRUSIVE ELECTRIC ACTUATORS

TYPE:

The actuators shall have integral starters with built in SPP (Single Phasing Preventer). 415 V, 3 phase 3 wire power supply shall be given to the actuator from switch board as applicable through a switch fuse unit. Control voltage of the motor starter shall be 110 V AC / 24 V DC, derived suitably from 415V power supply.

The actuators shall be Non- Intrusive electric actuator. All actuator settings including torque, limit shall be possible without opening the actuator cover and LCD indication shall be available integral to actuator body.

RATING:

- (a) Supply Voltage & frequency: 415V +/- 10%, 3 Phase, 3 Wire & 50HZ +/-5%.
 - (b) Sizing: Open/Close at rated speed against designed differential pressure at 90% of rated voltage.
- For ON/OFF type: Three successive open-close operations or 15 minutes, whichever is higher.

For inching type: 150 starts per hour or required cycles, whichever is higher.

CONSTRUCTION:

- (a) Enclosure: Totally enclosed weatherproof, minimum IP-68 degree of protection.
- (b) Manual Wheel: Shall disengage automatically during motor operation.

MOTOR:

- (a) Type : Squirrel cage induction motor suitable for Direct On Line (DOL) starting.

- (b) Enclosure: Totally enclosed, self-ventilated.
- (c) Insulation Class F. Temperature rise 70 Deg C. over 50 Deg C ambient.
- (d) Bearings: Double shielded, grease lubricated antifriction.
- (e) Earth Terminals: Two
- (f) Protection: Single Phasing Protection, Over heating protection through Thermostat (as applicable) and wrong phase sequence protection shall be provided over and above other protection features standard to bidder's design. Suitable means shall be provided to diagnose the type of fault locally.

POSITION/TORQUE TRANSMITTER:

The Position/ Limit measurement shall be done using absolute encoders which will give information of position/ limit in both the directions. Electronic measurement of torque shall be provided.

LOCAL OPERATION:

It shall be possible to operate the actuator locally also. Lockable local/remote selection shall be provided on the actuator.

LCD DISPLAY:

A local LCD display shall be provided to give information regarding actuator alarms, status and valve position indications as a minimum in local.

WIRING:

Suitable voltage grade copper wire.

TERMINAL BLOCK:

For power cables, the grade of TBs shall be minimum 650V.

ACCESSORIES:

All required accessories (if applicable) for calibration / settings/ configuration of various parameters of actuator shall be provided.

2. SPECIFIC REQUIREMENTS FOR NON INTRUSIVE HARDWIRED ACTUATORS

INTERFACES:

For ON-OFF and INCHING type actuators interface with the control system shall be through hardwired signal only.

- (a) Open/Close command, open/ close status and disturbance monitoring signal (common contact for Overload, Thermostat, control supply failure, L/R selector switch at local & other protections operated) shall be provided hardwired.
- (b) The actuator shall be able to accept open/close command at 24V DC with max. 2.5VA load from control system. Accordingly suitable isolated interface in the actuator shall be provided.
- (c) Open/close command termination logic shall be suitably built inside actuator.

TERMINAL BOX:

Suitable terminals/ connectors, integral to actuator, for terminating instrumentation & power cables shall be provided. Necessary glands for power cables and instrumentation cables shall be provided.

3. SPECIFIC REQUIREMENTS FOR NON INTRUSIVE FIELDBUS ACTUATORS

INTERFACES:

For ON-OFF and INCHING type actuators interface with the control system shall be through fieldbus network.

- (a) Open/ close commands, open/ close feedback status, disturbance signal etc. shall be available to the Control System through the fieldbus network along with diagnostics. The detailed diagnostics including the actuator operating data shall be available to the DDCMIS through the fieldbus network.
- (b) All actuators shall be Foundation Fieldbus/ Profibus compatible. However the exact protocol shall be based on finalized protocol of DDCMIS. If Profibus DP protocol is envisaged then actuator shall have two (redundant) Profibus DP ports for connecting the redundant Profibus DP cables. That is if one profibus cable is cut or not working/ not available, then complete actuator functionality shall be available through the second redundant cable without any manual intervention.
- (c) Open/close command termination logic shall be suitably built inside actuator.

4. TERMINAL BOX:

Suitable terminals/ connectors, integral to actuator, for terminating fieldbus cables and power cables shall be provided. Necessary glands for power cables and armored fieldbus cables shall be provided.

ANNEXURE-14

SPARES for Wet ball mill Piping (Water, Slurry & Instrument Air), Valves, Pneumatic distributor box and instruments				
SL NO	ITEM DESCRIPTION	QTY	MAT CODE	Remarks
1	MILL CIRCUIT SLURRY VALVES	1 set	BA9789222017	one set is 1 NO.OF EACH TYPE & SIZE
2	MILL CIRCUIT SLURRY LINE BENDS	1set	BA9789222025	one set is 1 NO.OF EACH TYPE & SIZE
3	TRANSMITTERS/GAUGES/SWITCHES ,ETC.ALONG WITH ACCESSORIES	1 set	BA9789222033	ONE SET is 5% OF TOTAL OR ATLEAST 1 NO (WHICHEVER IS HIGHER) FOR EACH TYPE ALONG WITH ACCESSORIES.
4	TEMPERATURE (RTD/THERMO-COUPLE) WITH THERMOWELL	1 sets	BA9789222041	ONE SET is 5% OF EACH TYPE, RANGE AND IMMERSION LENGTH OR MINIMUM 2 NOS (WHICHEVER IS HIGHER)