

**ITEM: ELECTRO FORGED FLOOR GRILL 32X305X6000 AS PER
DRG:1-35-811-02525/09 for NTPC PATRATU PROJECT**

REMARKS:

1. THE VENDOR SHALL FOLLOW THE STANDARD QUALITY PLAN CQP:4731/REV 00 DATED 21.06.2012.
2. THE VENDOR SHALL SUBMIT ALL THE CREDENTIALS AS PER PQR REQUIREMENT.
3. THE VENDOR SHALL SUBMIT THE TEST CERTIFICATE AND GUARANTEE CERTIFICATE.
4. THE VENDOR OFFER SHALL BE CONSIDERED SUBJECT TO CUSTOMER APPROVAL.
5. THE VENDOR SHALL PROVIDE ALL THE DOCUMENTS AS PER THE NTPC FORMAT FOR TAKING UP WITH CUSTOMER FOR APPROVAL.

1-35-811-02525

FOR TOLERANCES OF UNTOLERANCED DIMENSIONS DURING MANUFACTURE REFER PLANT STD. NO TP 023 0299

TYPE & SIZE OF WELD	TYPE OF ELECTRODE
4 Δ	E7018 (SMAW/GMAW)

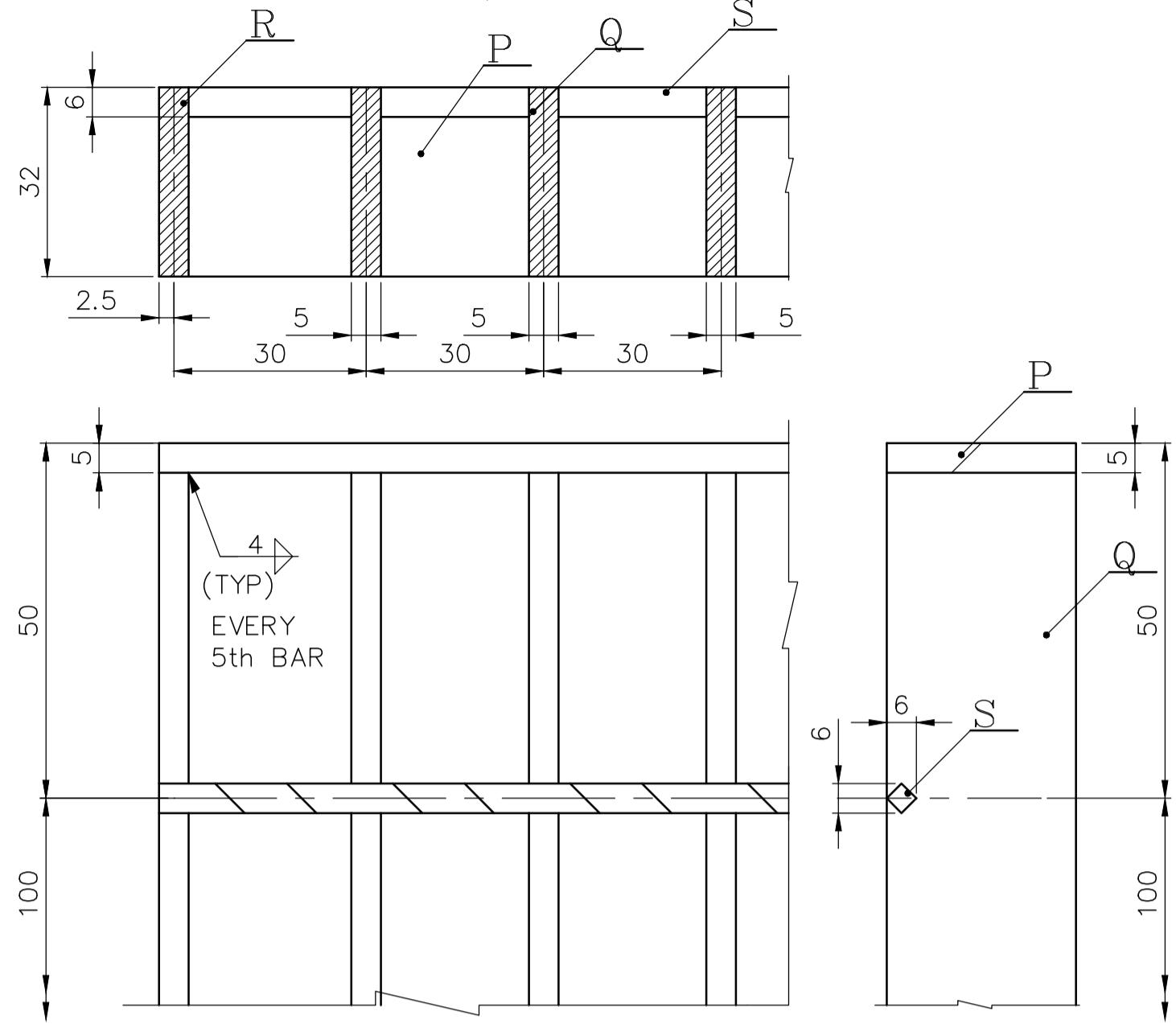
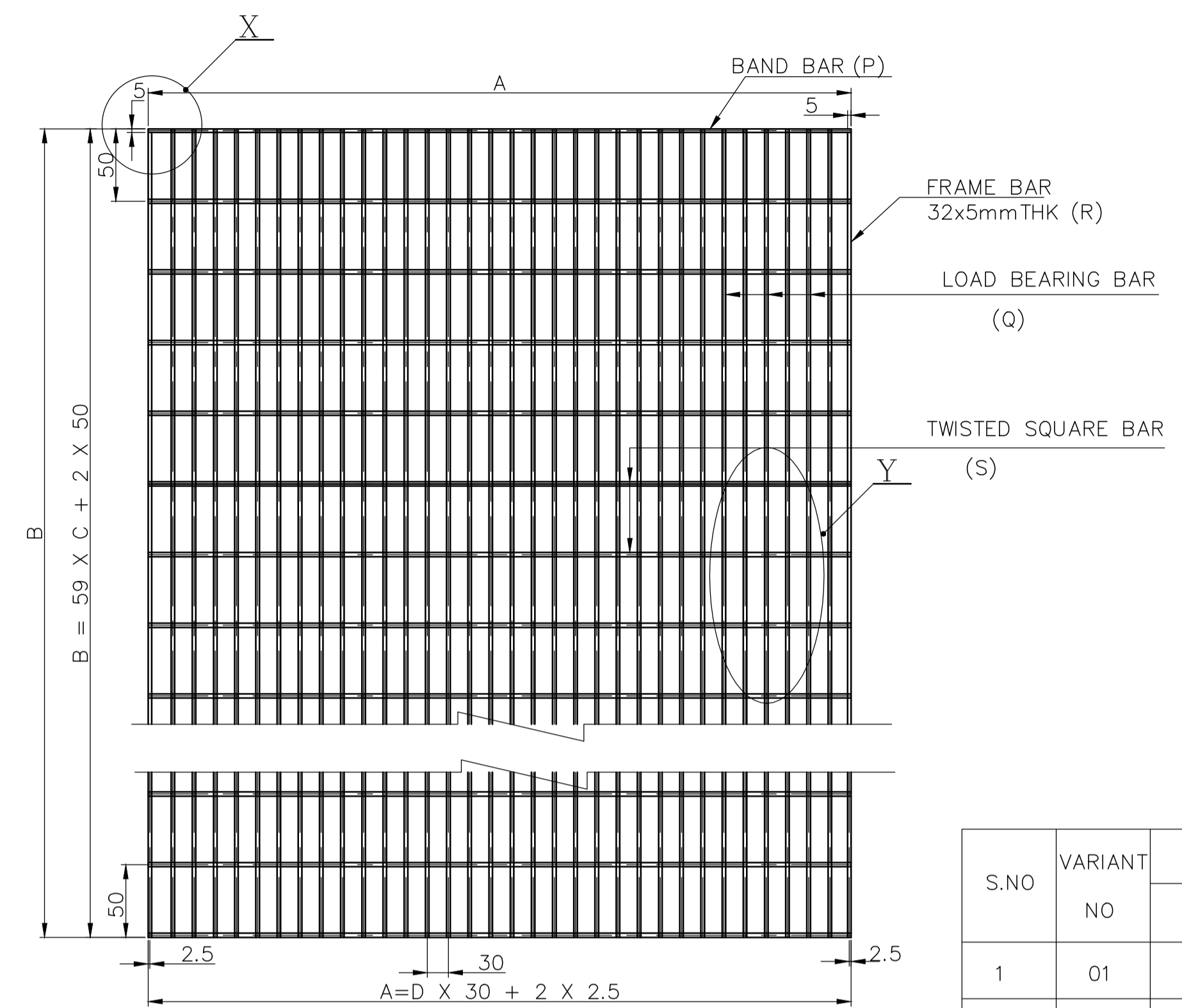

DETAIL-X

S.NO	VARIANT NO	SIZE OF FLOOR GRILL				ITEM NO/NO.OFF								WT. PER FLOOR GRILL BEFORE GALVANISING IN KG	WT. PER FLOOR GRILL AFTER GALVANISING IN KG
		WIDTH A	LENGTH B	C	D	P	Q	R	S						
1	01	305	6000	100	10	01	2	02	9	03	2	04	60	86.099	89.288
2	02	515	6000	100	17	05	2	06	16	07	2	08	60	141.088	146.319
3	03	995	6000	100	33	09	2	10	32	11	2	12	60	266.742	276.639

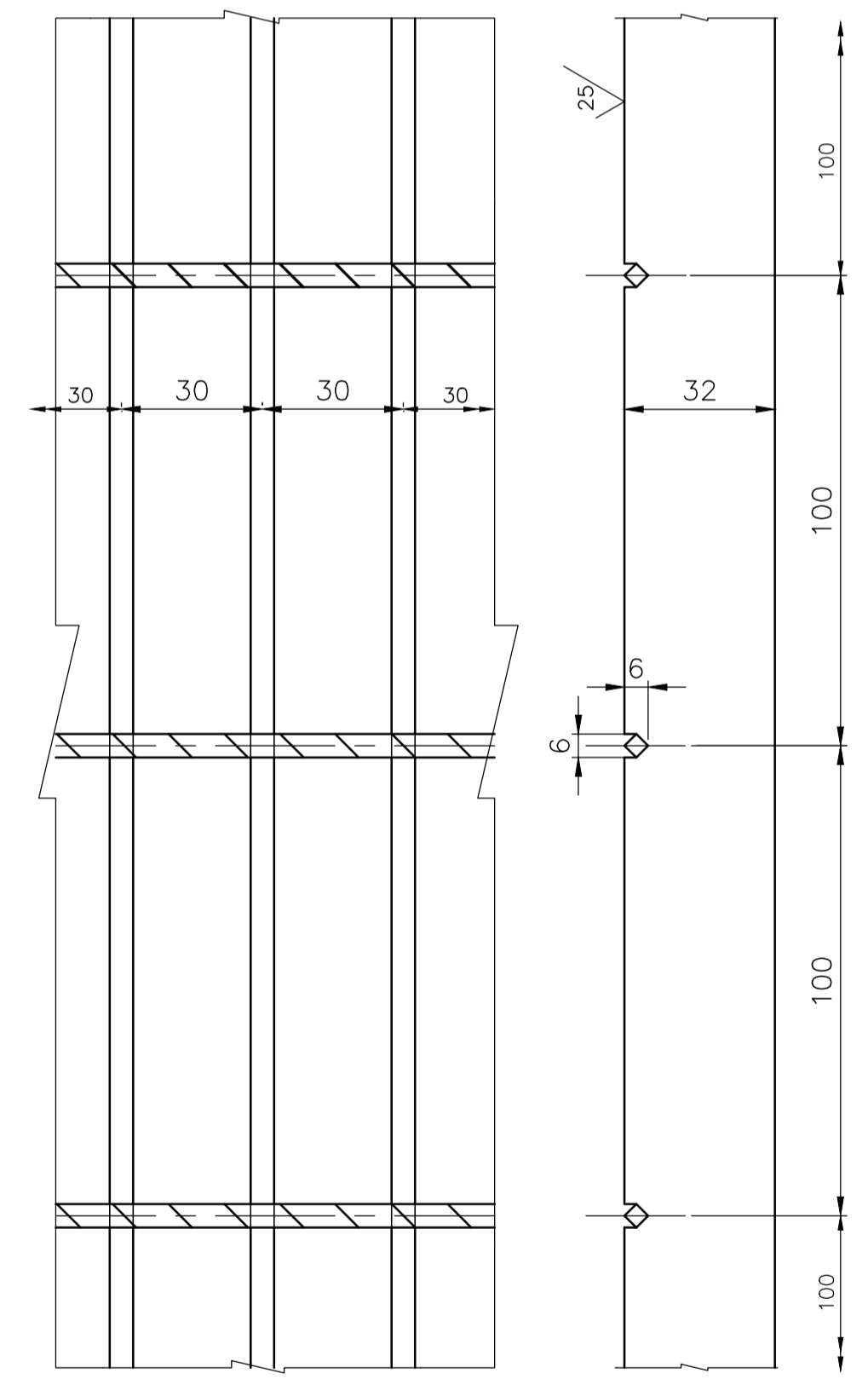

DETAIL-Y

NOTES:-

- FLOOR GRATINGS ARE TO BE GALVANISED BY HOT DIP PROCESS AFTER CLEANING BY PICKLING PROCESS. MINIMUM AVERAGE WEIGHT OF ZINC COATING SHALL BE 610 GRAMS PER SQ. METRE.
- STRUCTURAL STEEL CONFORMING TO SPECIFICATION IS 2062 E250A ONLY ARE TO BE USED
- GALVANISING TO BE DONE AFTER ALL WORKS ARE COMPLETED.
- ALL SCRATCHED SURFACES AND AREAS DAMAGED BY SITE WELDING SHALL RECEIVE ATLEAST TWO COATS OF COLD GALVANISING USING ZINC RICH PRIMER /PAINTS. THE TOTAL DRY FILM THICKNESS OF SUCH TOUCH UP COLD GALVANISING SHALL NOT BE LESS THAN 150 MICRONS.
- DESIGN LIVE LOAD FOR FLOOR GRILL = 1000 KG/SQ.M
- ALL GRATING MEMBERS ARE TO BE ELECTROFORGED EXCEPT BAND BARS.
- WEIGHT OF FLOOR GRILL INDICATED DOES NOT INCLUDE WEIGHT OF WELD, WHICH IS NEGLIGIBLE.
- FLOOR GRATINGS ARE SUPPORTED BY INTERMITTENT FLOOR BEAMS SUCH THAT, FLOOR GRATINGS TAKE LIVE LOAD AS PER NOTE NO. 05 AND MAXIMUM DEFLECTION IS LIMITED TO L /250 OR 6MM WHICHEVER IS MINIMUM WHERE THE SPAN OF SUPPORTS (L) WILL BE 1.5M MAXIMUM.
- FRAME AND LOAD BEARING BAR WELDING : ALL FOUR CORNERS TO BE FULL WELDED TO BAND BARS AND EVERY FIFTH LOAD BEARING BAR TO BE WELDED TO BAND BAR BY MANUAL WELDING FULL DEPTH, AT BOTH ENDS FROM ONE SIDE.
- GRATINGS (32mm THICK) ARE FOR OUT DOOR APPLICATION
- TOLERANCE FOR LENGTH AND WIDTH OF GRATINGS SHALL BE ±5 mm

VARIANT NUMBER	ITEM NUMBER	DESCRIPTION	STD	DRAWING NUMBER	ITEM NO	MATERIAL CODE	UNIT	UNIT WEIGHT	QTY	ZONE
03	12	TWISTED SQ. BAR 6mm (DIAGONAL)X 995				IS1786 Fe500		0.141		
03	11	FLAT 5 X 32 X 5990				IS2062 E250A		7.523	2	
03	10	FLAT 5 X 32 X 5990				IS2062 E250A		7.523	32	
03	09	FLAT 5 X 32 X 995				IS2062 E250A		1.250	2	
02	08	TWISTED SQ. BAR 6mm (DIAGONAL)X 515				IS1786 Fe500		0.073		
02	07	FLAT 5 X 32 X 5990				IS2062 E250A		7.523	2	
02	06	FLAT 5 X 32 X 5990				IS2062 E250A		7.523	16	
02	05	FLAT 5 X 32 X 515				IS2062 E250A		0.647	2	
01	04	TWISTED SQ. BAR 6mm (DIAGONAL)X 305				IS1786 Fe500		0.043		
01	03	FLAT 5 X 32 X 5990				IS2062 E250A		7.523	2	
01	02	FLAT 5 X 32 X 5990				IS2062 E250A		7.523	9	
01	01	FLAT 5 X 32 X 305				IS2062 E250A		0.383	2	

REV	DATE	ALTD.	CHD	APPD	REV	DATE	ALTD.	CHD	APPD	REV	DATE	ALTD.	CHD	APPD
06	03.01.08	kesavan	PENCHAL	RJK	05	10-06-05	KARTHIK	PENCHAL	RJK	04	20-05-05	KARTHIK	PENCHAL	RJK
03	10.09.03		SKR	RRS	02	21.08.03		SKR	RRS	01	04-05-08	kesavan	PENCHAL	RJK

REV	DATE	ALTD.	CHD	APPD	REV	DATE	ALTD.	CHD	APPD	REV	DATE	ALTD.	CHD	APPD
09	12.02.2013	PRAKASH	MPR	MPR	08	22.02.12	PRAKASH	MPR	RRS	07	04-05-08	kesavan	PENCHAL	RJK
03	10.09.03		SKR	RRS	02	21.08.03		SKR	RRS	01	04-05-08	kesavan	PENCHAL	RJK

CAUTION: THE DRAWING IS THE PROPERTY OF BHARAT HEAVY ELECTRICALS LTD. AND IS NOT TO BE REPRODUCED OR USED TO FURNISH ANY INFORMATION FOR MAKING OF DRAWINGS OR APPARATUS EXCEPT WHERE PROVIDED BY AGREEMENT WITH SHD COMPANY.

BHARAT HEAVY ELECTRICALS LTD	DEPT CODE	DRN	S.MANIVANNAN	SIGN	DATE
UNIT-HIGH PRESSURE BOILER PLANT	ST122	CHD	S.K.RAMAN		31/05/03
TIRUCHIRAPPALLI-620 014	APPD	R.RAMASAMY			31/05/03

TITLE: **LONG SPAN FLOOR GRILL - 32MM**
(6 TWISTED SQUARE - GALVANISED)

BHEL DRG NO. **1-35-811-02525**

SCALE:

REV. 09

	MANUFACTURER'S NAME & ADDRESS BHEL: TIRUCHIRAPPALLI	STANDARD QUALITY PLAN						QP NO.: CQP 4731				
	APPROVED SUB-CONTRACTOR	ITEM: ELECTROFORGE FLOOR GRILLS & STEP TREADS						REV.NO.00 DATE: 21/06/2012				
		SUB-SYSTEM : Steam Generator and Auxiliaries,						PAGE: 1 OF 1				
SL. NO.	COMPONENT & OPERATIONS	CHARACTERISTICS	CLASS	TYPE OF CHECK	QUANTUM OF CHECK	REFERENCE DOCUMENT	ACCEPTANCE NORMS	FORMAT OF RECORD	AGENCY			REMARKS
1	2	3	4	5	6	7	8	9	D*	**	10	11

1.0 RAW MATERIAL:													
1.1	Bearing Bar. Square Twisted Bar Chequered Plate & other Support plates	Chemical Properties Mechanical Properties Physical Properties	B	Verification of Record	100%	As per BHEL Purchase order(PO)/ BHEL drawing/Material Specification//Laboratory test report./ Test certificate..		MTC	√	P	V	V	Witness of raw material for BHEL Purchase order requirement by BHEL/BHEL AIA. Refer Note-1
			B	Lab analysis	1 No per / PO			MTC	√	P	W	W	
			B	Visual, Dimensions Straightness Surface finish	At random			IR	√	P	W	W	
2.0 IN PROCESS CONTROL:													
2.1	Checks on EF weld machines	Weld parameters, Weld quality Straightness of bars Mesh size and other Dimensions of grating	B	Machine setting Measurement & Visual checks. (Projection & Fusion of weld)	6 times per Shift	WPS / PQR(ASME Sec-1) / BHEL Drawing	IR / Log book	√	P	W	V	Square twisted bar welding shall be properly fused with Bearing bar.	
			B	Load test	Once per Shift **	By applying 20Kg Pull load on weld joint.	Log book	√	P	W	V	** Random	
2.2	Pull out test on EF Weld. And Macro Etch test	Strength test	B	Lab test	1 No per / PO	Manufacturers practice	LTC	√	P	W	W	Shall be carried out in a NABL appd.lab./ Manufacturers own lab.	
2.3	Manual welds in Step treads	Weld parameters, Weld Size & quality	B	Visual inspection for weld defects	100%	WPS / PQR(ASME Sec-1) / AWS D 1.1/ BHEL Drawing /Free from defects	Log book	√	P	W	V		
2.4	Dimensions	Physical	B	Measurement	100%	As per BHEL Purchase order & BHEL drawing	DR	√	P	W	V#	#Witness by BHEL AIA - 2%/ Per size/ PO.	
3.0 TESTS													
3.1	Deflection Load test (Before galvanizing)	Physical / Dial gauge	B	Measurement	1No./ Per size/ PO.	BHEL Purchase order/ BHELAppd Drawing.	IR	√	P	W	W	Refer Note: 2	
3.2	Galvanizing	1.Visual 2.Mass of zinc 3.Adhesion 4.Preece Test 5.Coating Thickness	B	Visual, Lab test Measurement	As per Standard IS2629, IS 4759, IS2633	As per BHEL Purchase order, BHEL drawing.	Log Book, IR	√	P	W	V*	* Witness of testing on One sample per PO identified by BHEL / BHEL AIA.	
4.0	PACKING, CRATING AND IDENTIFICATION	Bundling / Identification /Protection	B	Visual	100%	Shall be tied with steel strip/Compact packing BHEL PO.No & Item No shall be stenciled.	IR		P	V	V		

LEGEND:

J. Nanthini 21/06/2012 J.NANTHINI	 21/6/12 V.KALYANARAMAN	Note: (1) Samples shall be selected by BHEL/BHEL AIA for the offered inspection lot. Testing shall be done in a NABL approved lab / Suppliers own lab in the presence of BHEL/BHEL AIA. (2) Deflection shall be measured with a dial gauge by applying a Uniformly Distributed Load-1000Kg.per Sq. meter. Floor Grill shall be placed on two vertical supports-1200mm. apart. Deflection=1200/325 = 3.69mm.
PREPARED	APPROVED	Legend: * Records, indentified with "Tick" (√) shall be essentially included by SUPPLIER in QA documentation. ** M: Manufacturer
SIGNATURE		C: MANUFACTURERS ' QC N: BHEL / BHEL AIA P: PERFORM. W: witness. V: verification , CHP: customer shall identify in column N "N" AS ' W' CLASS : A - CRITICAL ; B - MAJOR ; C - MINOR . MTC: Mill test certificate. LTC: Lab test certificate. IR: Inspection Report. DR: Dimension Report.

BHEL/TRICHY
MM/BOI/PURCHASE

Pre-Qualification requirements (PQR) for the procurement of Floor Grills as per specification through Open Tender

A: Organizational Capability & Technical Competence:

Sl. No.	Pre –Qualification Criteria	Bidder acceptance / Bidder remarks
1	Offers from bidders having basic in house manufacturing facilities for the enquired items are only eligible to participate. Offer from Traders, Distributors are not acceptable and will not be considered for evaluation. Vendor to indicate the nature of the Firm. (Trader/Distributor/Manufacturer). Product catalogue shall be submitted.	
2	Manufacturing plant address & available equipment's for manufacturing the tendered items shall be provided along with offer.	
3	Suppliers shall submit Quality Management System certificate or Written down procedure.	

B: Past Experience/ Performance:

Sl. No.	Pre –Qualification Criteria	Bidder acceptance / Bidder remarks
1.	The supplier shall have supplied same or similar items for 50% of the bid quantity (in terms of Metric Tonnes) for the respective Package. PO Copies with corresponding proof of supply shall be furnished.	

C. Financial Soundness:

Sl. No.	Pre –Qualification Criteria	Bidder acceptance / Bidder remarks
1.	Indigenous suppliers shall submit copies of annual reports (balance sheets), profit & Loss Statement for the last three years (or from date of incorporation whichever is less) and GST Certificate.	

Necessary supporting documents shall be submitted for meeting each of the above Pre-Qualification Criteria for technical evaluation of the offers.

BHEL reserves the right to consider/Not-consider the offers based on the evaluation of documents submitted for the above Pre-Qualification Criteria. If required, BHEL also reserves the right to verify information submitted by vendor. In case the information is found false/incorrect, the offer shall be rejected. BHEL also reserves the right to carry out audit checks for confirming the material properties on the supplied material during material receipt at BHEL. Supplies found defective during check or subsequent processing at BHEL will be rejected.



CORPORATE QUALITY ASSURANCE
SUB-VENDOR QUESTIONNAIRE

i.	Item/Scope of Sub-contracting	
ii.	Address of the registered office	Details of Contact Person <i>(Name, Designation, Mobile, Email)</i>
iii.	Name and Address of the proposed Sub-vendor's works where item is being manufactured	Details of Contact Person: <i>(Name, Designation, Mobile, Email)</i>
iv.	Annual Production Capacity for proposed item/scope of sub-contracting	
v.	Annual production for last 3 years for proposed item/scope of sub-contracting	
vi.	Details of proposed works	
1.	Year of establishment of present works	
2.	Year of commencement of manufacturing at above works	
3.	Details of change in Works address in past (if any)	
4.	Total Area	
	Covered Area	
5.	Factory Registration Certificate	Details attached at Annexure – F2.1
6.	Design/ Research & development set-up <i>(No. of manpower, their qualification, machines & tools employed etc.)</i>	Applicable / Not applicable if manufacturing is as per Main Contractor/purchaser design Details attached at Annexure – F2.2 <i>(if applicable)</i>
7.	Overall organization Chart with Manpower Details <i>(Design/Manufacturing/Quality etc)</i>	Details attached at Annexure – F2.3
8.	After sales service set up in India, in case of foreign sub-vendor <i>(Location, Contact Person, Contact details etc.)</i>	Applicable / Not applicable Details attached at Annexure – F2.4
9.	Manufacturing process execution plan with flow chart indicating various stages of manufacturing from raw material to finished product including outsourced process, if any	Details attached at Annexure – F2.5
10.	Sources of Raw Material/Major Bought Out Item	Details attached at Annexure – F2.6
11.	Quality Control exercised during receipt of raw material/BOI, in-process , Final Testing, packing	Details attached at Annexure – F2.7



CORPORATE QUALITY ASSURANCE
SUB-VENDOR QUESTIONNAIRE

12.	Manufacturing facilities (List of machines, special process facilities, material handling etc.)	<i>Details attached at Annexure – F2.8</i>			
13.	Testing facilities (List of testing equipment)	<i>Details attached at Annexure – F2.9</i>			
14.	If manufacturing process involves fabrication then-	<i>Applicable / Not applicable</i>			
	List of qualified Welders	<i>Details attached at Annexure – F2.10</i>			
	List of qualified NDT personnel with area of specialization	<i>(if applicable)</i>			
15.	List of out-sourced manufacturing processes with Sub-Vendors' names & addresses	<i>Applicable / Not applicable</i> <i>Details attached at Annexure. –F2.11</i> <i>(if applicable)</i>			
16.	Supply reference list including recent supplies	<i>Details attached at Annexure – F2.12</i> <i>(as per format given below)</i>			
Project/ package	Customer Name	Supplied Item (Type/Rating/Model /Capacity/Size etc)	PO ref no/date	Supplied Quantity	Date of Supply
17.	Product satisfactory performance feedback letter/certificates/End User Feedback	<i>Attached at annexure - F2.13</i>			
18.	Summary of Type Test Report (Type Test Details, Report No, Agency, Date of testing) for the proposed product (similar or higher rating) <i>Note:- Reports need not to be submitted</i>	<i>Applicable / Not applicable</i> <i>Details attached at Annexure – F2.14</i> <i>(if applicable)</i>			
19.	Statutory / mandatory certification for the proposed product	<i>Applicable / Not applicable</i> <i>Details attached at Annexure – F2.15</i> <i>(if applicable)</i>			
20.	Copy of ISO 9001 certificate (if available)	<i>Attached at Annexure – F2.16</i>			
21.	Product technical catalogues for proposed item (if available)	<i>Details attached at Annexure – F2.17</i>			
Name:		Desig:		Sign:	
				Date:	

Company's Seal/Stamp:-

**ITEM: ELECTRO FORGED FLOOR GRILL 32X515X6000 AS PER
DRG:1-35-811-02525/09 for NTPC PATRATU PROJECT**

REMARKS:

1. THE VENDOR SHALL FOLLOW THE STANDARD QUALITY PLAN CQP:4731/REV 00 DATED 21.06.2012.
2. THE VENDOR SHALL SUBMIT ALL THE CREDENTIALS AS PER PQR REQUIREMENT.
3. THE VENDOR SHALL SUBMIT THE TEST CERTIFICATE AND GUARANTEE CERTIFICATE.
4. THE VENDOR OFFER SHALL BE CONSIDERED SUBJECT TO CUSTOMER APPROVAL.
5. THE VENDOR SHALL PROVIDE ALL THE DOCUMENTS AS PER THE NTPC FORMAT FOR TAKING UP WITH CUSTOMER FOR APPROVAL.

1-35-811-02525

FOR TOLERANCES OF UNTOLERANCED DIMENSIONS DURING MANUFACTURE REFER PLANT STD. NO TP 023 0299

TYPE & SIZE OF WELD	TYPE OF ELECTRODE
4 Δ	E7018 (SMAW/GMAW)

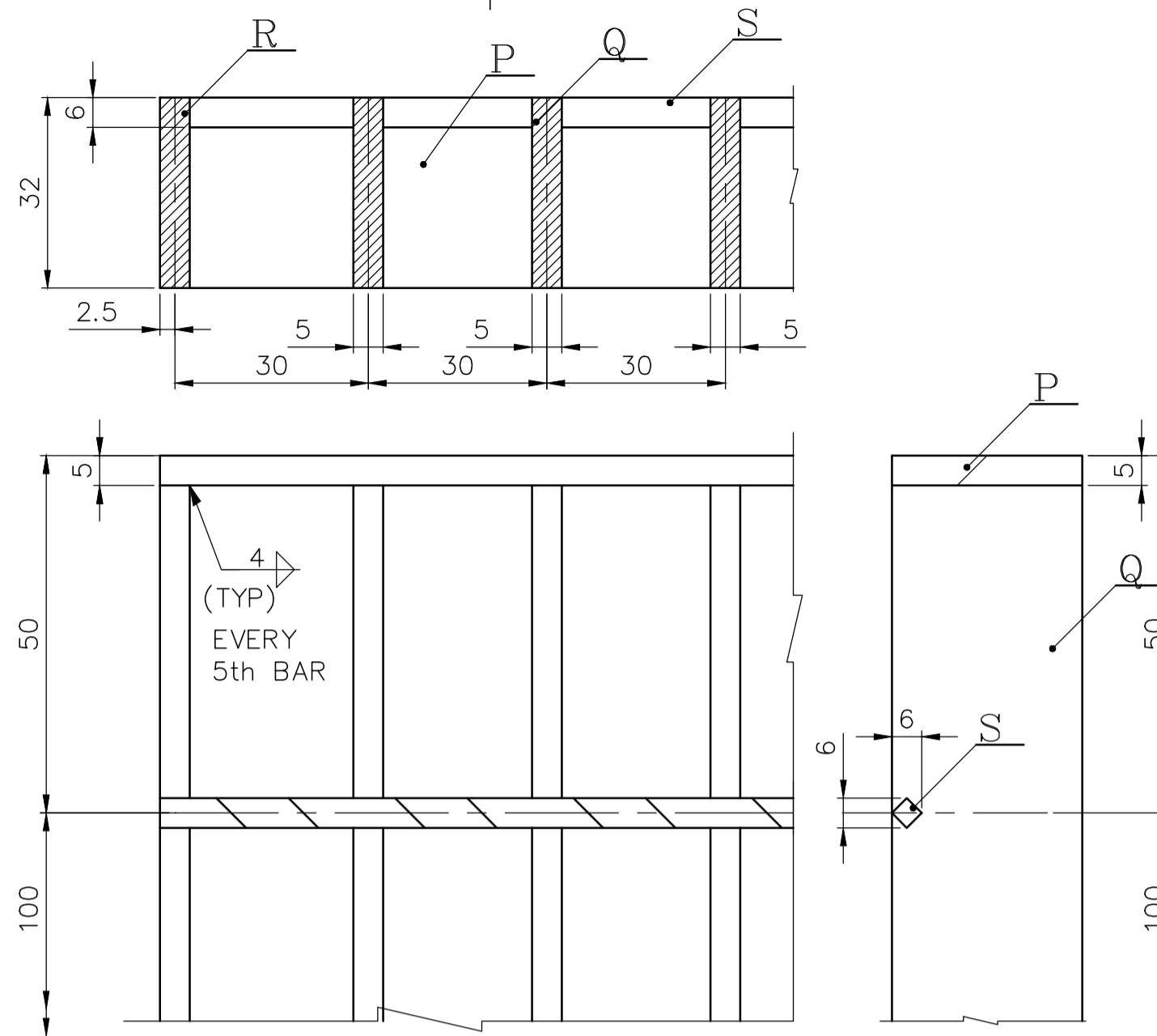

DETAIL-X

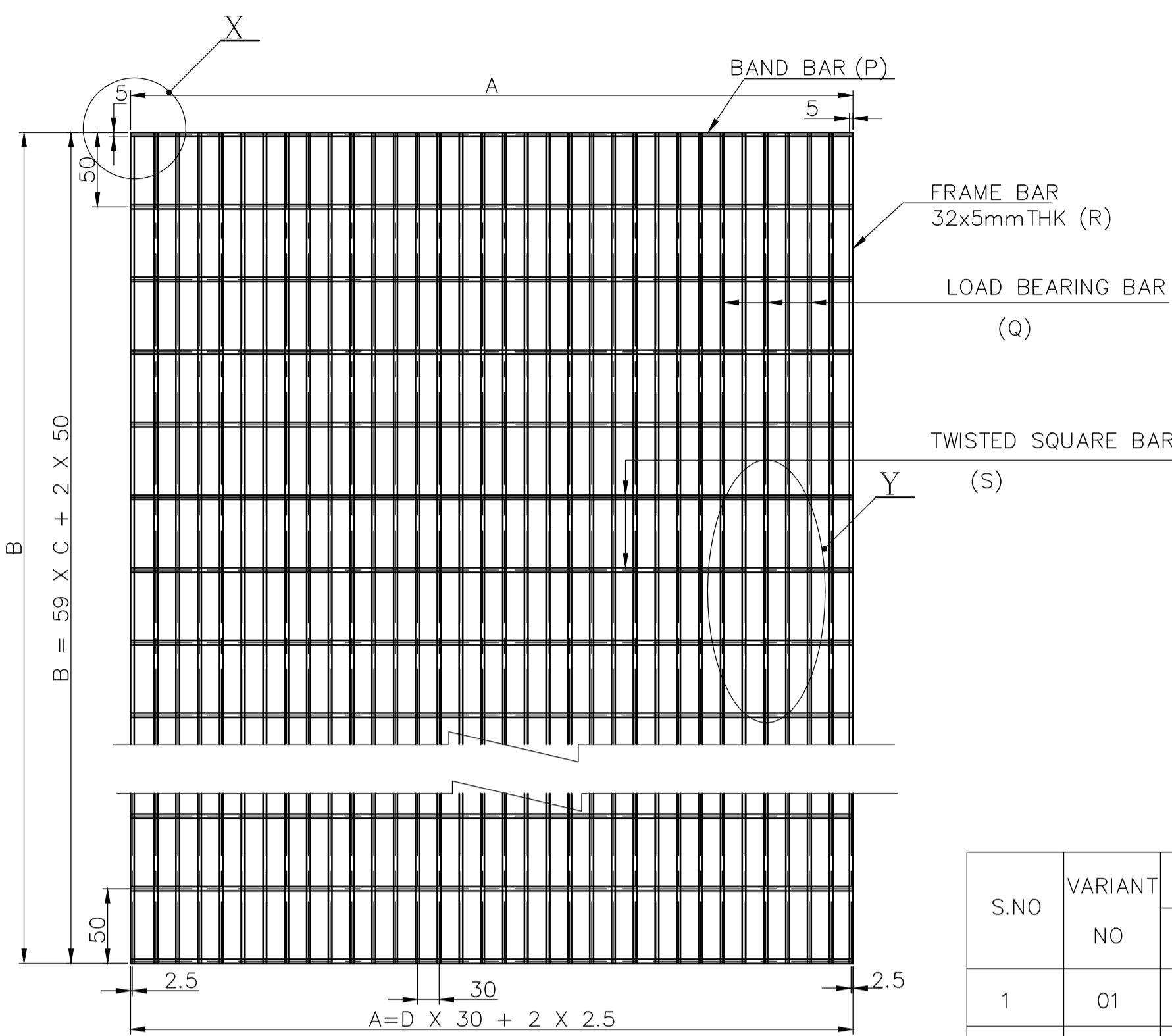

S.NO	VARIANT NO	SIZE OF FLOOR GRILL				ITEM NO/NO.OFF								WT. PER FLOOR GRILL BEFORE GALVANISING IN KG	WT. PER FLOOR GRILL AFTER GALVANISING IN KG
		WIDTH A	LENGTH B	C	D	P	Q	R	S						
1	01	305	6000	100	10	01	2	02	9	03	2	04	60	86.099	89.288
2	02	515	6000	100	17	05	2	06	16	07	2	08	60	141.088	146.319
3	03	995	6000	100	33	09	2	10	32	11	2	12	60	266.742	276.639

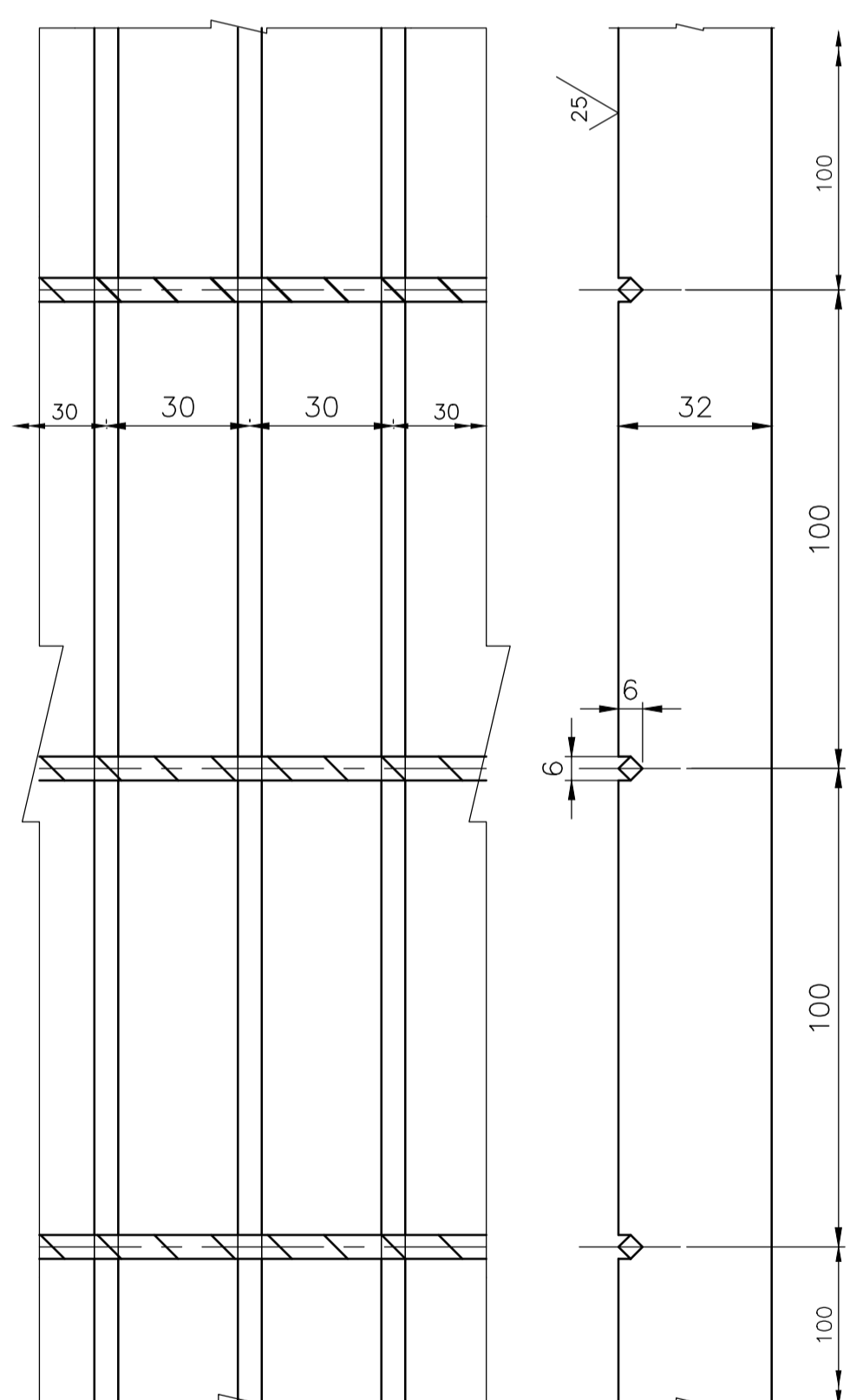

DETAIL-Y

NOTES:-

- FLOOR GRATINGS ARE TO BE GALVANISED BY HOT DIP PROCESS AFTER CLEANING BY PICKLING PROCESS. MINIMUM AVERAGE WEIGHT OF ZINC COATING SHALL BE 610 GRAMS PER SQ. METRE.
- STRUCTURAL STEEL CONFORMING TO SPECIFICATION IS 2062 E250A ONLY ARE TO BE USED
- GALVANISING TO BE DONE AFTER ALL WORKS ARE COMPLETED.
- ALL SCRATCHED SURFACES AND AREAS DAMAGED BY SITE WELDING SHALL RECEIVE ATLEAST TWO COATS OF COLD GALVANISING USING ZINC RICH PRIMER /PAINTS. THE TOTAL DRY FILM THICKNESS OF SUCH TOUCH UP COLD GALVANISING SHALL NOT BE LESS THAN 150 MICRONS.
- DESIGN LIVE LOAD FOR FLOOR GRILL = 1000 KG/SQ.M
- ALL GRATING MEMBERS ARE TO BE ELECTROFORGED EXCEPT BAND BARS.
- WEIGHT OF FLOOR GRILL INDICATED DOES NOT INCLUDE WEIGHT OF WELD, WHICH IS NEGLIGIBLE.
- FLOOR GRATINGS ARE SUPPORTED BY INTERMITTENT FLOOR BEAMS SUCH THAT, FLOOR GRATINGS TAKE LIVE LOAD AS PER NOTE NO. 05 AND MAXIMUM DEFLECTION IS LIMITED TO L /250 OR 6MM WHICHEVER IS MINIMUM WHERE THE SPAN OF SUPPORTS (L) WILL BE 1.5M MAXIMUM.
- FRAME AND LOAD BEARING BAR WELDING : ALL FOUR CORNERS TO BE FULL WELDED TO BAND BARS AND EVERY FIFTH LOAD BEARING BAR TO BE WELDED TO BAND BAR BY MANUAL WELDING FULL DEPTH, AT BOTH ENDS FROM ONE SIDE.
- GRATINGS (32mm THICK) ARE FOR OUT DOOR APPLICATION
- TOLERANCE FOR LENGTH AND WIDTH OF GRATINGS SHALL BE ±5 mm

VARIANT NUMBER	ITEM NUMBER	DESCRIPTION	STD	DRAWING NUMBER	ITEM NO	MATERIAL CODE	UNIT	UNIT WEIGHT	QTY	ZONE
03	12	TWISTED SQ. BAR 6mm (DIAGONAL)X 995				IS1786 Fe500		0.141		
03	11	FLAT 5 X 32 X 5990				IS2062 E250A		7.523	2	
03	10	FLAT 5 X 32 X 5990				IS2062 E250A		7.523	32	
03	09	FLAT 5 X 32 X 995				IS2062 E250A		1.250	2	
02	08	TWISTED SQ. BAR 6mm (DIAGONAL)X 515				IS1786 Fe500		0.073		
02	07	FLAT 5 X 32 X 5990				IS2062 E250A		7.523	2	
02	06	FLAT 5 X 32 X 5990				IS2062 E250A		7.523	16	
02	05	FLAT 5 X 32 X 515				IS2062 E250A		0.647	2	
01	04	TWISTED SQ. BAR 6mm (DIAGONAL)X 305				IS1786 Fe500		0.043		
01	03	FLAT 5 X 32 X 5990				IS2062 E250A		7.523	2	
01	02	FLAT 5 X 32 X 5990				IS2062 E250A		7.523	9	
01	01	FLAT 5 X 32 X 305				IS2062 E250A		0.383	2	

REV	DATE	ALTD.	CHD	APPD	REV	DATE	ALTD.	CHD	APPD	REV	DATE	ALTD.	CHD	APPD
06	03.01.08	kesavan	PENCHAL	RJK	05	10-06-05	KARTHIK	PENCHAL	RJK	04	20-05-05	KARTHIK	PENCHAL	RJK
09	12.02.2013	PRAKASH	MPR	MPR	08	22.02.12	PRAKASH	MPR	RRS	07	04-05-08	kesavan	PENCHAL	RJK
03	10.09.'03	SKR	SKR	RRS	02	21.08.03	SKR	SKR	RRS	01				

CAUTION: THE DRAWING IS THE PROPERTY OF BHARAT HEAVY ELECTRICALS LTD. AND IS NOT TO BE REPRODUCED OR USED TO FURNISH ANY INFORMATION FOR MAKING OF DRAWINGS OR APPARATUS EXCEPT WHERE PROVIDED BY AGREEMENT WITH SHD COMPANY.

BHARAT HEAVY ELECTRICALS LTD	DEPT CODE	DRN	S.MANIVANNAN	SIGN	DATE
UNIT-HIGH PRESSURE BOILER PLANT	ST122	CHD	S.K.RAMAN		31/05/03
TIRUCHIRAPPALLI-620 014	APPD	R.RAMASAMY			31/05/03

TITLE: **LONG SPAN FLOOR GRILL - 32MM**
(6 TWISTED SQUARE - GALVANISED)

BHEL DRG NO. **1-35-811-02525**

SCALE:

REV. 09

	MANUFACTURER'S NAME & ADDRESS BHEL: TIRUCHIRAPPALLI	STANDARD QUALITY PLAN						QP NO.: CQP 4731				
	APPROVED SUB-CONTRACTOR	ITEM: ELECTROFORGE FLOOR GRILLS & STEP TREADS						REV.NO.00 DATE: 21/06/2012				
		SUB-SYSTEM : Steam Generator and Auxiliaries,						PAGE: 1 OF 1				
SL. NO.	COMPONENT & OPERATIONS	CHARACTERISTICS	CLASS	TYPE OF CHECK	QUANTUM OF CHECK	REFERENCE DOCUMENT	ACCEPTANCE NORMS	FORMAT OF RECORD	AGENCY			REMARKS
1	2	3	4	5	6	7	8	9	D*	**	10	11

1.0 RAW MATERIAL:												
1.1	Bearing Bar. Square Twisted Bar Chequered Plate & other Support plates	Chemical Properties Mechanical Properties Physical Properties	B	Verification of Record	100%	As per BHEL Purchase order(PO)/ BHEL drawing/Material Specification//Laboratory test report./ Test certificate..	MTC	√	P	V	V	Witness of raw material for BHEL Purchase order requirement by BHEL/BHEL AIA. Refer Note-1
			B	Lab analysis	1 No per / PO			√	P	W	W	
			B	Visual, Dimensions Straightness Surface finish	At random			IR	√	P	W	
2.0 IN PROCESS CONTROL:												
2.1	Checks on EF weld machines	Weld parameters, Weld quality Straightness of bars Mesh size and other Dimensions of grating	B	Machine setting Measurement & Visual checks. (Projection & Fusion of weld)	6 times per Shift	WPS / PQR(ASME Sec-1) / BHEL Drawing	IR / Log book	√	P	W	V	Square twisted bar welding shall be properly fused with Bearing bar.
		Weld Strength	B	Load test	Once ** per Shift	By applying 20Kg Pull load on weld joint.	Log book	√	P	W	V	** Random
2.2	Pull out test on EF Weld. And Macro Etch test	Strength test	B	Lab test	1 No per / PO	Manufacturers practice	LTC	√	P	W	W	Shall be carried out in a NABL appd.lab./ Manufacturers own lab.
2.3	Manual welds in Step treads	Weld parameters, Weld Size & quality	B	Visual inspection for weld defects	100%	WPS / PQR(ASME Sec-1) / AWS D 1.1/ BHEL Drawing /Free from defects	Log book	√	P	W	V	
2.4	Dimensions	Physical	B	Measurement	100%	As per BHEL Purchase order & BHEL drawing	DR	√	P	W	V#	#Witness by BHEL AIA - 2%/ Per size/ PO.
3.0 TESTS												
3.1	Deflection Load test (Before galvanizing)	Physical / Dial gauge	B	Measurement	1No./ Per size/ PO.	BHEL Purchase order/ BHELAppd Drawing.	IR	√	P	W	W	Refer Note: 2
3.2	Galvanizing	1.Visual 2.Mass of zinc 3.Adhesion 4.Preece Test 5.Coating Thickness	B	Visual, Lab test Measurement	As per Standard IS2629, IS 4759, IS2633	As per BHEL Purchase order, BHEL drawing.	Log Book, IR	√	P	W	V*	* Witness of testing on One sample per PO identified by BHEL / BHEL AIA.
4.0	PACKING, CRATING AND IDENTIFICATION	Bundling / Identification /Protection	B	Visual	100%	Shall be tied with steel strip/Compact packing BHEL PO.No & Item No shall be stenciled.	IR		P	V	V	

LEGEND:

J. Nanthini 21/06/2012 J.NANTHINI	 21/6/12 V.KALYANARAMAN	Note: (1) Samples shall be selected by BHEL/BHEL AIA for the offered inspection lot. Testing shall be done in a NABL approved lab / Suppliers own lab in the presence of BHEL/BHEL AIA. (2) Deflection shall be measured with a dial gauge by applying a Uniformly Distributed Load-1000Kg.per Sq. meter. Floor Grill shall be placed on two vertical supports-1200mm. apart. Deflection=1200/325 = 3.69mm.
PREPARED	APPROVED	Legend: * Records, indentified with "Tick" (√) shall be essentially included by SUPPLIER in QA documentation. ** M: Manufacturer
SIGNATURE		C: MANUFACTURERS ' QC N: BHEL / BHEL AIA P: PERFORM. W: witness. V: verification , CHP: customer shall identify in column N "N" AS ' W'
CLASS : A - CRITICAL ; B - MAJOR ; C - MINOR . MTC: Mill test certificate. LTC: Lab test certificate. IR: Inspection Report. DR: Dimension Report.		

BHEL/TRICHY
MM/BOI/PURCHASE

Pre-Qualification requirements (PQR) for the procurement of Floor Grills as per specification through Open Tender

A: Organizational Capability & Technical Competence:

Sl. No.	Pre –Qualification Criteria	Bidder acceptance / Bidder remarks
1	Offers from bidders having basic in house manufacturing facilities for the enquired items are only eligible to participate. Offer from Traders, Distributors are not acceptable and will not be considered for evaluation. Vendor to indicate the nature of the Firm. (Trader/Distributor/Manufacturer). Product catalogue shall be submitted.	
2	Manufacturing plant address & available equipment's for manufacturing the tendered items shall be provided along with offer.	
3	Suppliers shall submit Quality Management System certificate or Written down procedure.	

B: Past Experience/ Performance:

Sl. No.	Pre –Qualification Criteria	Bidder acceptance / Bidder remarks
1.	The supplier shall have supplied same or similar items for 50% of the bid quantity (in terms of Metric Tonnes) for the respective Package. PO Copies with corresponding proof of supply shall be furnished.	

C. Financial Soundness:

Sl. No.	Pre –Qualification Criteria	Bidder acceptance / Bidder remarks
1.	Indigenous suppliers shall submit copies of annual reports (balance sheets), profit & Loss Statement for the last three years (or from date of incorporation whichever is less) and GST Certificate.	

Necessary supporting documents shall be submitted for meeting each of the above Pre-Qualification Criteria for technical evaluation of the offers.

BHEL reserves the right to consider/Not-consider the offers based on the evaluation of documents submitted for the above Pre-Qualification Criteria. If required, BHEL also reserves the right to verify information submitted by vendor. In case the information is found false/incorrect, the offer shall be rejected. BHEL also reserves the right to carry out audit checks for confirming the material properties on the supplied material during material receipt at BHEL. Supplies found defective during check or subsequent processing at BHEL will be rejected.



CORPORATE QUALITY ASSURANCE
SUB-VENDOR QUESTIONNAIRE

i.	Item/Scope of Sub-contracting	
ii.	Address of the registered office	Details of Contact Person <i>(Name, Designation, Mobile, Email)</i>
iii.	Name and Address of the proposed Sub-vendor's works where item is being manufactured	Details of Contact Person: <i>(Name, Designation, Mobile, Email)</i>
iv.	Annual Production Capacity for proposed item/scope of sub-contracting	
v.	Annual production for last 3 years for proposed item/scope of sub-contracting	
vi.	Details of proposed works	
1.	Year of establishment of present works	
2.	Year of commencement of manufacturing at above works	
3.	Details of change in Works address in past (if any)	
4.	Total Area	
	Covered Area	
5.	Factory Registration Certificate	Details attached at Annexure – F2.1
6.	Design/ Research & development set-up <i>(No. of manpower, their qualification, machines & tools employed etc.)</i>	Applicable / Not applicable if manufacturing is as per Main Contractor/purchaser design Details attached at Annexure – F2.2 <i>(if applicable)</i>
7.	Overall organization Chart with Manpower Details <i>(Design/Manufacturing/Quality etc)</i>	Details attached at Annexure – F2.3
8.	After sales service set up in India, in case of foreign sub-vendor <i>(Location, Contact Person, Contact details etc.)</i>	Applicable / Not applicable Details attached at Annexure – F2.4
9.	Manufacturing process execution plan with flow chart indicating various stages of manufacturing from raw material to finished product including outsourced process, if any	Details attached at Annexure – F2.5
10.	Sources of Raw Material/Major Bought Out Item	Details attached at Annexure – F2.6
11.	Quality Control exercised during receipt of raw material/BOI, in-process , Final Testing, packing	Details attached at Annexure – F2.7



**CORPORATE QUALITY ASSURANCE
SUB-VENDOR QUESTIONNAIRE**

12.	Manufacturing facilities (List of machines, special process facilities, material handling etc.)	<i>Details attached at Annexure – F2.8</i>			
13.	Testing facilities (List of testing equipment)	<i>Details attached at Annexure – F2.9</i>			
14.	If manufacturing process involves fabrication then-	<i>Applicable / Not applicable</i>			
	List of qualified Welders	<i>Details attached at Annexure – F2.10</i>			
	List of qualified NDT personnel with area of specialization	<i>(if applicable)</i>			
15.	List of out-sourced manufacturing processes with Sub-Vendors' names & addresses	<i>Applicable / Not applicable</i> <i>Details attached at Annexure. –F2.11</i> <i>(if applicable)</i>			
16.	Supply reference list including recent supplies	<i>Details attached at Annexure – F2.12</i> <i>(as per format given below)</i>			
Project/ package	Customer Name	Supplied Item (Type/Rating/Model /Capacity/Size etc)	PO ref no/date	Supplied Quantity	Date of Supply
17.	Product satisfactory performance feedback letter/certificates/End User Feedback	<i>Attached at annexure - F2.13</i>			
18.	Summary of Type Test Report (Type Test Details, Report No, Agency, Date of testing) for the proposed product (similar or higher rating) <i>Note:- Reports need not to be submitted</i>	<i>Applicable / Not applicable</i> <i>Details attached at Annexure – F2.14</i> <i>(if applicable)</i>			
19.	Statutory / mandatory certification for the proposed product	<i>Applicable / Not applicable</i> <i>Details attached at Annexure – F2.15</i> <i>(if applicable)</i>			
20.	Copy of ISO 9001 certificate (if available)	<i>Attached at Annexure – F2.16</i>			
21.	Product technical catalogues for proposed item (if available)	<i>Details attached at Annexure – F2.17</i>			
Name:		Desig:		Sign:	
				Date:	

Company's Seal/Stamp:-



An ISO 9001
Company

Bharat Heavy Electricals Limited

(High Pressure Boiler Plant)
Tiruchirappalli-620 014, Tamil Nadu, India
Dept: MATERIALS MANAGEMENT/BOI

Annexure – TC- Additional Terms and Conditions for GeM Enquiry

The terms and condition mentioned in this document are applicable in addition to the GeM General Terms and Conditions. Bidders shall furnish pointwise confirmation/details.

Description of the Equipment:	ELECTRO FORGED FLOOR GRILLS
Projects	PATRATU PROJECT
BHEL Tender No. & Date	
Name of the firm (Bidder)	:
Address	:
Contact details	<p><u>Contact person 1</u> Name: Designation: Office Phone: Mobile: e-mail:</p> <p><u>Contact person 2</u> Name: Designation: Office Phone: Mobile: e-mail:</p>

To be filled by bidder

Sl. No.	Terms and conditions	Vendor's confirmation
1 (a)	<p>Technical: Bidder shall comply the specification requirements as per respective catalogues. Any clarifications/deviations to the specification requirements are to be clearly indicated. Hidden deviations indicated elsewhere in the offer will not be evaluated.</p> <p>Quality Plan shall be as per our Standard SQP .</p>	
1 (b)	<p>Pre-qualification requirement: Offer shall be considered only if bidder is meeting Tender Prequalification requirement. Vendor to comply with Pre-Qualification requirement of the tender and submit along with their technical bid - the credentials and other documents as indicated in the PQR in the format prescribed. Otherwise their offer will get rejected.</p>	
1 (c)	<p>Inspection by BHEL/ BHEL approved TPIA/Customer.</p>	
1(d)	<p>Vendor offers will considered for price bid opening subject to fulfilment of techno commercial suitability and vendor approval by end customer. The required credentials are to be submitted as per the attached NTPC format (Attached in the respective catalogue)</p>	
2	<p>Firm Price:</p>	

	The quoted / finalised rates shall be Firm till execution of the supplies. Offer with PVC clause will not be considered.	
3	<p>Delivery term: The quote shall be on FOR/Patratu Project Site inclusive of Packing, forwarding, Freight also to yours account.</p> <p>PACKAGE 1 – PATRATU PROJECT</p> <ul style="list-style-type: none"> FOR/JHARKAND <p>Transit Insurance is under BHEL scope.</p>	
4	<p>TENDER FINALIZATION: Tender will be finalized on total package basis through Reverse Auction in GeM</p>	
5 (a)	<p>Guarantee / Warranty Period: 18 months from the date of supply or 12 months from date of commissioning, whichever is earlier.</p>	
5 (b)	<p>Repair & replacements: Within the guarantee period vendor has to replace / rectify the defective/ damaged items on free of cost within a reasonable time of reporting from our end.</p>	
5 (c)	<p>Loading Criteria: Guarantee / Warranty Period: No Deviation is permitted. If still vendor offered any deviation on the Guarantee / warranty period, it may lead to rejection of offer.</p>	
6 (a)	Kindly Indicate the HSN Code for all items	
6 (b)	Rate quoted in GeM portal should be on FOR destination basis inclusive of all taxes, freight etc. Transit Insurance is under BHEL scope. Please indicate the applicable GST %.	
7 (a)	<p>Delivery Period:</p> <ul style="list-style-type: none"> Delivery Period shall be 90 Days from the date of manufacturing clearance <p>Material shall be dispatched after obtaining dispatch clearance from BHEL.</p> <p>Delivery period mentioned anywhere else in the bid document is for indicative purpose. Delivery schedule shall be as per this clause.</p>	
7 (b)	<p>Document Submission: In case of PO placements, required documents have to be submitted for approval within 15 days from the date of PO & reply for any further clarification has to be within 4 days. Any delay beyond the above specified period will be considered during LD calculation.</p>	
8	Invoice date/Bill of Lading date/Airway Bill date/Lorry way bill date/Railway Receipt date, whichever is later will be considered for LD calculation.	
9	<p>Documents are to be submitted along with technical bid (Part-1)</p> <ol style="list-style-type: none"> Covering letter Unpriced offer. Filled technical specification and BHEL datasheets. Filled BHEL Terms and condition sheet (Annexure-A) Filled in PQR along with supporting documents. GA Drawing Self-Certification as per Make In India clause 	

	<p>08. MSE Certificates (if applicable)</p> <p>Note: All the pages of documents are to be signed and sealed by authorized signatory of the company. Any query during enquiry stage shall be replied within two days failing which offer may be rejected as non-responsive.</p>	
10	<p>Inspection and testing requirements:</p> <p>Inspection and testing requirements are to be carried out as per the specification and BHEL/Customer approved Drawing (All documents shall be submitted within 15 days from the date of PO for our approval), Technical spec & QP and all test certificates are to be submitted in complete set.</p> <p>Inspection notice period: For TPI inspector visit to vendor works, a minimum of 3 working days' notice period.</p>	
11	<p>Supplier shall mention their GSTN registration number in all their invoices and invoices shall be in the format as specified/prescribed under GST laws. Invoices shall necessarily contain Invoice number (in case of multiple numbering system is being followed for billing like SAP invoice no, commercial invoice no etc., then the Invoice No which is linked/uploaded in GSTN network shall be clearly indicated), item description as per PO, Quantity, Rate, Value, applicable taxes with nomenclature (like IGST, SGST, CGST & UTGST) separately, HSN/ SAC Code, etc.</p>	
12	<p>All invoices shall bear the HSN Code for each item separately (Harmonized System of Nomenclature)/ SAC code (Services Accounting Code).</p>	
13	<p>Invoices will be processed only upon completion of statutory requirement and further subject to following:</p> <ul style="list-style-type: none"> • Vendor declaring such invoice in Form GST ANX-1 • Receipt of Goods or Services and Tax invoice by BHEL 	
14	<p>As the continuous uploading of tax invoices in GSTN portal (in GST ANX-1) is available for all (i.e. both Small & Large) tax payers under proposed new GST Return System, all invoices raised on BHEL may be uploaded immediately in GST portal on despatch of material /rendering of services. The supplier shall ensure availability of Invoice in GST portal before submission of invoice to BHEL. Invoices will be admitted by BHEL only if the invoices are available in GSTN portal (in BHEL's GST ANX-2).</p>	
15	<p>In case of discrepancy in the data uploaded by the supplier in the GSTN portal or in case of any shortages or rejection in the supply, then BHEL will not be able to avail the tax credit and will notify the supplier of the same. Supplier has to rectify the data discrepancy in the GSTN portal or issue credit note or debit note (details also to be uploaded in GSTN portal) for the shortages or rejections in the supplies or additional claims, within the calendar month informed by BHEL.</p>	
16	<p>In cases where invoice details have been uploaded by the vendor but failed to remit the GST amount to GST Department (Form PMT-08 or Form GST RET-01 to be submitted) within stipulated time, then GST paid on the invoices pertaining to the month for which GST return not filed by the vendor will be recovered from the vendor along with the applicable interest (currently 24% p.a) and all subsequent bills of the vendor will not be processed till filing of the GST return by the vendor</p>	

17	In case GST credit is denied to BHEL due to non-receipt or delayed receipt of goods and/ or tax invoice or expiry of timeline prescribed in GST law for availing such ITC, or any other reasons not attributable to BHEL, GST amount claimed in the invoice shall be disallowed to the vendor.	
18	Where any GST liability arising on BHEL under Reverse Charge (RCM), the vendor has to submit the invoices to BHEL well within the timeline prescribed in GST Law, to enable BHEL to discharge the GST liability. If there is a delay in submission of invoice by the vendor resulting in delayed payment of GST by BHEL along with Interest, then such Interest payable or paid shall be recovered from the vendor.	
19	Under GST regime, BHEL has to discharge GST liability on LD recovered from suppliers/contracts. Hence applicable GST shall also be recoverable from suppliers/contractors on LD amount. For this Tax Invoice will be issued by BHEL indicating the respective supply invoice number.	
20	GST TDS will be deducted as per Section 51 of CGST Act 2017 and in line with Notification 50/2018 – Central Tax dated 13.09.2018. GST TDS certificate which will be generated in GST portal subsequent to vendor accepting the TDS deduction in the GST portal, will be issued to the vendor.	
21	A declaration to the effect that all invoice particulars are/were uploaded in the GSTN network/ portal & all tax liability as per GST rules and regulations have been and will be discharged, shall be mentioned in the invoice. If not mentioned in the invoice, a separate declaration shall be submitted as per the requirement of BHEL	
22	MSE VENDOR: <i>Udyam Registration certificate shall be submitted by MSE vendors for availing the benefits.</i>	
23	<u>Make in India:</u> The local supplier at the time of tender, bidding or solicitation shall be required to provide self-certification that the item offered meets the minimum local content and shall give details of the location (s) at which the local value addition is made.	
24	<u>Fraud Prevention Policy</u> Bidder along with its associate /collaborators /sub-contractors /sub-vendors / consultants / service providers shall strictly adhere to BHEL Fraud Prevention Policy displayed on BHEL website http://www.bhel.com and shall immediately bring to the notice of BHEL Management about any fraud or suspected fraud as soon as it comes to their notice.	
25	<u>PRICE IMPACT:</u> All the technical / commercial details given in the enquiry shall be taken care and offer shall be quoted accordingly. No price impact / implication will be accepted within the validity period.	
26	<u>BHEL reserve the right to inspect the item ordered at any stage at vendor's works and if found not meeting the stipulated conditions, material is liable for rejection</u>	

27	Payment Term: 100% direct EFT payment within 60 days from the date of issue of consignee receipt-cum-acceptance certificate (CRAC).	
Note	<ol style="list-style-type: none">1. In the event of our customer order covering this tender being cancelled /placed on hold / otherwise modified, BHEL would be constrained to accordingly cancel / hold / modify the tender at any stage of execution.2. BHEL may negotiate the L1 rate, if not meeting our budget / estimated cost. BHEL may re-float the tender opened, if L1 price is not acceptable to BHEL.3. BHEL reserves its right to reject an offer due to unsatisfactory past performance by the respective Vendor in the execution of any contract to any BHEL project / Unit.4. Any other Techno –Commercial Terms indicated by the vendor in their offer elsewhere will be ignored. BHEL will proceed with tender evaluation as per Annexure A only.	

/ On Bidder's office letter pad /
Self-Declaration – ANNEXURE B

Enquiry No.	
Enquiry Date	

In line with Government public procurement order Number P-45021/2/2017-B.E-II dated 15.06.2017, and further modified order dt. 28.05.2018 & order 04.06.2020 issued by DPIIT

I / We hereby declare that I / We are a “Local Supplier” meeting the requirement of minimum local content (.....%) defined in the above government notification for the goods against above mentioned enquiry Number.

Details of location at which local value addition will be made is as follows:

Door No.	
Street / Address 1	
Street / Address 2	
District	
State	
Country	
PIN Code	

We also understand that the false declarations will be considered as breach of Integrity and liable for action.

For Company Name:

Seal:

Signature:

Date:

Place:

(Please fill all the yellow color field)

Annexure-D

SUB-DELIVERY ENQUIRY DEVIATION FORMAT

	MATERIALS MANAGEMENT / BOI SUB-DELIVERY ENQUIRY DEVIATION FORMAT	
Schedule of deviation to Sub-delivery Enquiry No.	:	
Description	:	
Technical Specifications Document	:	
Drawing Nos.	:	DRG:1-35-811-02525/09
Quality Plan	:	STANDARD QUALITY PLAN CQP:4731/REV 00 DATED 21.06.2012.
Packing Procedure	:	
Document reference	BHEL called for	Firm's
Certified that other than the above deviations, we are accepting all the other specifications and requirements in full to your Enquiry.		
Station :		
Date :	Signature of firm's representative	Firm seal
Note :	1. Deviations should be taken only in the extreme case 2. If necessary, use additional sheets with page control number	

CERTIFIED THAT OTHER THAN THE ABOVE DEVIATIONS, WE ARE ACCEPTING ALL THE OTHER SPECIFICATIONS AND REQUIREMENTS IN FULL TO YOUR ENQUIRY

STATION:

DATE:

SIGNATURE OF FIRMS REPRESENTATIVE

FIRM SEAL

1. Deviations should be taken only in the extreme case.
2. If necessary, use additional sheets with page control number.