

TECHNICAL SPECIFICATION
FOR
CONTROL VALVES WITH ACCESSORIES
(Pneumatically Operated)

1 X 660 MW BHUSAWAL TPP

VOLUME - IIB

SECTIONS-A, C & D

SPECIFICATION No: PE-TS-415-145-I801



BHARAT HEAVY ELECTRICALS LIMITED
POWER SECTOR
PROJECT ENGINEERING MANAGEMENT DIVISION
NOIDA, INDIA



Technical specification for
Control Valves with Accessories
(Pneumatically Operated)

SPEC NO.: PE-TS-415-145-I801

DOCUMENT NO.

VOLUME II B

SECTION A

ISSUE NO. 2

REV. NO. 00

DATE 10.01.2020

CONTENTS**VOL-II B**

SECTION	DESCRIPTION
A	Scope of Enquiry
C	Specific Technical Requirements
	Customer's Specification
	Datasheets-A&B (Data sheet no. PES-145-06-DS1-1)
	Datasheets-C (Data sheet no. PES-145-06-DS2-1)
	Quality Plan
	Bill of Quantity - Main Supply
	Bill of Quantity - Spares
D	Equipment Specification (PES – 145 – 06) 29
	Specification for Smart Positioner (PES – 145 – 06A) 35
	Hook-Up Diagram (PES-145-06B) 39
	Guideline for Packing (PES-145-06C) 45
	Specification for Electric Actuator (PES-145-06D) 47



Technical specification for
Control Valves with Accessories
(Pneumatically Operated)

SPEC NO.: **PE-TS-415-145-I801**

DOCUMENT NO.

VOLUME II B

SECTION A

ISSUE NO. 2

REV. NO. 00

DATE 10.01.2020

SECTION – A

SCOPE OF ENQUIRY

	Technical specification for Control Valves with Accessories (Pneumatically Operated)	SPEC NO.: PE-TS-415-145-I801	
		DOCUMENT NO.	
		VOLUME	II B
		SECTION	A
		ISSUE NO.	2
REV. NO.	00	DATE	10.01.2020

SCOPE OF ENQUIRY

1. SCOPE

- 1.1 This specification covers the Design, Manufacture, Inspection and testing at manufacturer's works, proper packing for transportation and delivery to site of the **Control Valves with Pneumatic Actuator along with Accessories, Start-up/Commissioning Spares & Mandatory spares** as mentioned in different sections of this specification for **1 X 660 MW BHUSA WAL TPP** project. **The enquiry is in compliance mode.**
- 1.2 The quality plan enclosed forms the minimum requirement but not limited to be adhered to by the bidder. Bidder to sign and stamp the same and submit along with the offer as an acceptance.
- 1.3 Following signed & stamped documents with company seal to be submitted by bidder.
- a) Compliance Certificate , Complete offer including calculation sheets, catalogues etc.
 - b) Quality Plan
 - c) Datasheet A & B, duly filled
 - d) Schedule of prices & unit prices, inspection schedule
 - e) Schedule of submission of drawings/documents, equipment manufacture, inspection & dispatch.

2 GENERAL TECHNICAL INSTRUCTIONS

- 2.1 It is not the intent here to specify all the details of design and manufacture. However, the equipment shall conform in all respects to high standard of design, engineering and workmanship and shall be capable of performing the required duties in a manner acceptable to the customer / consultant, who will interpret the meaning of drawing and specification and shall be entitled to reject any component or material which in his judgment is not in full accordance herewith.
- 2.2 The omission of specific reference to any component / accessory necessary for the proper performance of the equipment shall not relieve the supplier of the responsibility of providing such facilities to complete the supply within the quoted prices.
- 2.3 BHEL' s / Customer' s representatives shall be given access to the shop in which the equipment are being manufactured or tested and all test records shall be made available to them.
- 2.4 The Equipment covered under this specification shall not be dispatched unless the same have been finally inspected, accepted and Material Dispatch Clearance Certificate (MDCC) is issued by BHEL / Customer.
- 2.5 The enquiry is in compliance mode means bidder to comply technical specification in totality & submit compliance certificate attached in the specification.



Technical specification for
Control Valves with Accessories
(Pneumatically Operated)

SPEC NO.: PE-TS-415-145-I801

DOCUMENT NO.

VOLUME II B

SECTION A

ISSUE NO. 2

REV. NO. 00

DATE 10.01.2020

SECTION – C

- **SPECIFIC TECHNICAL REQUIREMENT**
 - **CUSTOMER'S SPECIFICATION**
 - **DATA SHEETS – A & B**
- **DATA SHEETS– A & B FOR ACCESSORIES**
 - **DATA SHEETS – C**
 - **QUALITY PLAN**
 - **BOQ-MAIN SUPPLY**
 - **BOQ- SPARES**



Technical specification for
Control Valves with Accessories
(Pneumatically Operated)

SPEC NO.: PE-TS-415-145-I801

DOCUMENT NO.

VOLUME II B

SECTION A

ISSUE NO. 2

REV. NO. 00

DATE 10.01.2020

SPECIFIC TECHNICAL REQUIREMENTS

The requirements in this section are specific for this project and shall over-ride the specification under Section-D in case of any contradiction. However, in case of any contradiction between this SPECIFIC TECHNICAL REQUIREMENTS and customer SPECIFICATION attached further, the customer SPECIFICATION shall prevail and BHEL's decision shall be final. BIDDER to comply the stringent requirement as per BHEL decision without any commercial implication.

1. **All the formats in Volume-III, SCHEDULE OF SUBMISSION OF DRG. /DOC. and QUALITY PLAN (BHEL Format) should filled-up and furnished with the bid, complete in all respect. In the absence of those, the bid would be considered incomplete and liable for rejection.** Catalogue, Leaflets related with the models of Control Valves as well as each Accessory must be furnished with the offer.
2. The Hook-up diagram for Control valve, attached in Section-D. The scope demarcation as indicated should be adhered. The connection details at Instrument Air valve shall be furnished to successful bidder after the award of contract.
3. Valve Body Sizes shall be quoted to take care of the specification requirements like parameters, and limitations of Fluid outlet velocities, Noise Level etc. **However, Port (Trim) Sizes shall be selected to suit CV requirement for achieving percentage valve lift as per Technical Specification.**
4. Bidder to note that, **wherever downstream side of the valve is subjected to the Vacuum service, bidder to offer double Gland packing, and in that case, flow direction of working fluid shall be to close the valve.** Separate indication for the same has not been made in the data Sheets-A.
5. For valves subjected to cavitation service, anti-cavitation trim shall be provided.
6. In case during erection/commissioning of the control valve, any spares are required which have not been specified in the Start-up/commissioning spares list, the same will have to be supplied by the bidder free of cost.
7. Facility to adjust the maximum travel of the stem & starting point of travel shall be incorporated.

	Technical specification for Control Valves with Accessories (Pneumatically Operated)	SPEC NO.: PE-TS-415-145-I801	
		DOCUMENT NO.	
		VOLUME	II B
		SECTION	A
		ISSUE NO.	2
		REV. NO.	00

8. SS nameplate to control valve shall include Tag no./ KKS no./ Sl. No./ Body material/ size/ Press Rating/ Trim material/ Trim type/ action on air failure/ diaphragm air press at full open and close condition
9. Hand wheel shall have open/ close direction.
10. Limit switch shall be designed for 1,00,000 operations.
11. JB shall be 36 ways as per enclosed hook-up diagram.
12. The material of filter for Air Filter Regulator shall be ceramic/Sintered bronze.
13. Bidder to indicate pick-up & drop out voltage for all solenoid valves.
14. Protection class for Limit switches, I/P converter and Position transmitter shall be IP-65 only.
15. All JBs and valves shall be with double compression type Ni plated brass cable glands.
16. Solenoid valve class of protection shall be IP-65, shall be of Plug and socket electrical connection.
17. All local cabling up to JBs shall be in Conduit (Flexible/Rigid).
18. The smart positioner provided with Control Valves shall be compatible with Universal Hart Calibrator.
In order to interface with METSO system, the smart positioner of Control Valves has to be HART Compatible. Bidder to provide diagnostic software (for all tags) to be installed on HMS PC for communicating with the smart positioner and accessing the diagnostic features of the smart positioner. Bidder to offer latest version of calibration and diagnostic software which should be compatible with latest operating system at the time of commissioning of valve/positioner without any additional cost to BHEL. The offered software shall be compatible with the HART MANAGEMENT SYSTEM hardware of reputed makes like MTL, P&F etc. Additionally, Vendor to provide DTM (device type manager) / DTD (device type description) files for engineering.

	Technical specification for Control Valves with Accessories (Pneumatically Operated)	SPEC NO.: PE-TS-415-145-I801	
		DOCUMENT NO.	
		VOLUME	II B
		SECTION	A
		ISSUE NO.	2
REV. NO.	00	DATE	10.01.2020

19. Positioner shall have both fail freeze and fail safe feature.

20. Bidder to furnish **compliance certificate** duly signed and stamped by bidder attached further.

21. SPARES: The following spares are required to be offered

(A) Recommended Spares:

The bidder shall furnish a List of Recommended spares for 3 years of normal operation of the Control valves / Accessories. The BHEL/Customer reserves the right to buy any or all of the recommended spares.

The prices of these spares will remain valid for a period of minimum 6 months after the placement of order.

(B) Start-up & Commissioning Spares:

Start-up and Commissioning spares are those spares, which may be required during the start-up and commissioning of the Control Valves. All start-up spares, which are supplied under this contract, shall be strictly interchangeable with the parts for which they are intended for replacements. The format for price schedule to be filled-up by the bidder is enclosed in Volume-III

The Start-up and commissioning spares indicated by the bidder shall be a part of the main Control valves supply. However, bidder to indicate prices separately. The list of these spares required is enclosed in the Section-C of this specification.

Bidder to indicate the service life expectancy period for the spare parts under normal working conditions. The spares shall be treated and packed for long storage, under climatic conditions prevailing at site. Small items shall be packed in sealed transparent plastic bags with desiccator's packs as necessary.

(C) Mandatory spares:

Bidder to supply mandatory spares as attached in specification.

	Technical specification for Control Valves with Accessories (Pneumatically Operated)	SPEC NO.: PE-TS-415-145-I801	
		DOCUMENT NO.	
		VOLUME	II B
		SECTION	A
		ISSUE NO.	2
		REV. NO.	00

20. Documentation:

(A) After the award of contract:

The documentation as listed below for the project
6 sets of the following documents + 3 sets of CDs to be enclosed with the bids
for Approval:

- a. Assembly (dimensional) drawings.
- b. Valve Edge preparation details.
- c. Data sheet-C completely filled-up.
- d. Hook-up diagram of Control Valve with Actuator & Accessories.
- e. Valve & Actuator assembly dimensional drawings with weights.
- f. Quality Plan duly signed and stamped.
- g. All calculations like CV, Noise Level, Valve Outlet Velocity, Actuator sizing etc.
- h. All relevant catalogues for the models of the valves as well as accessories finalized.
- i. Bar chart to indicate the time schedule for procurement, manufacture, testing and dispatch.

(B) Final documentation:

The documentation as listed below will separate for respective projects

1. Category -I & IV Approved final drawings/data sheets, - 20 sets with 4 CD-ROMS
Valve sizing calculations, Noise level calculations and
Valve Outlet Velocity calculations.
2. Test certificates - 20 sets.
3. Operation & Maintenance Manuals - 20 sets with 4 CD-ROMS
for Control Valve, Actuator and all the
Accessories.



Technical specification for
Control Valves with Accessories
(Pneumatically Operated)

SPEC NO.: PE-TS-415-145-I801

DOCUMENT NO.

VOLUME II B

SECTION A

ISSUE NO. 2

REV. NO. 00

DATE 10.01.2020

COMPLIANCE CERTIFICATE

We shall comply with the following: -

1. All the requirements as stated in Technical Specification / Specific Technical requirement / Data sheets / Drawings, BHEL quality plan etc. as enclosed in the tender, shall be fully complied **without any deviation.**
2. BHEL Quality Plan (enclosed with the specification) duly signed and stamped is submitted herewith **without any deviation.**
3. Calculation of CV, Noise level, Valve outlet velocity, Trim exit velocity, Actuator sizing, Data Sheet-C in line with Data sheet-A of specification, dimensional drawings / edge preparation details, etc shall be submitted for BHEL/Customer review and approval, to reach BHEL within 15 days after receipt of LOI.
4. Selection of valves and Actuators are our (bidder's) responsibility. Any change in selection of type of valve and Actuators / Sizing / percentage opening, calculations, QP, etc., if desired by BHEL / Customer during approval of the documents after award of contract, without major changes in process parameters as per tender Specification, shall be carried out without any commercial implication and time delay.
5. Body material and Trim material combinations offered will be equivalent or better than the material specified in data Sheet-A. Wherever Trim material combinations offered differ from the specification, its superiority shall be authenticated with documentary evidence and justification produced for BHEL / Customer's concurrence. BHEL / Customer reserves the right to accept/rejects any variation to the specification.

**(To be Signed &
Stamped by the Bidder)**

Signature with date	
Name	
Company seal	



Technical specification for
Control Valves with Accessories
(Pneumatically Operated)

SPEC NO.: **PE-TS-415-145-I801**

DOCUMENT NO.

VOLUME II B

SECTION A

ISSUE NO. 2

REV. NO. 00

DATE 10.01.2020

CUSTOMER SPECIFICATION

 MAHAGENCO Maharashtra State Power Generation Co. Ltd.	MAHARASHTRA STATE POWER GENERATION CO. LTD.		Volume : V
	BID SPECIFICATION NO.:DG/BSL U-6/2011/T-1		Section – 5
REV: R0	CONTROL & INSTRUMENTATION		Page 293 of 718
SR. NO.	ITEM	DESCRIPTION	
	(k) Colour of letters	Black (for white windows)	
	(l) Facia front cover	Hi-impact polystyrene	
	(m) Facia rear plate	Translucent plastic	
	(n) Colour of background	Milk white and red for critical / trip.	
	(o) Fascia block plate	Cold rolled sheet steel epoxy painted.	
	(p) Audible alarm	Cone type speaker	
	(q) Tone generator	Electronic with adjustable tone, amplitude and frequency	
	(r) Preferred sequence	(i) Ordinary Channel : ISA-S-18.1-1979-R	
		(ii) First-up channel : ISA-S-16.1-1979- F3M3	
NOTE: 1. Instruments which are open to atmosphere should be covered with proper canopy.			
3.0 <u>CONTROL VALVES, ACTUATORS & ACCESSORIES</u> General Technical Guidelines for the Control Valves shall be as follows : (a) Bidder shall exercise caution in selecting severe service control valves like BFP recirculation valves, HP & LP bypass valves, superheater & reheater attemperator valves, PRDS valves for Boiler & Turbine, Soot blower steam pressure control valve, control valves whose down stream are connected to vacuum such as HP/LP heater emergency level control, condenser make up water control valve, separator level control and CEP minimum flow control valve. For such critical applications, Bidder shall offer valves which are proven			

CONSULTANT : PROCON ENGINEERS

 MAHAGENCO Maharashtra State Power Generation Co. Ltd.	MAHARASHTRA STATE POWER GENERATION CO. LTD.	Volume : V
	BID SPECIFICATION NO.:DG/BSL U-6/2011/T-1	Section – 5
REV: R0	CONTROL & INSTRUMENTATION	Page 294 of 718

for similar application. Above valves shall have leakage class equal or better than class-V with metal-to-metal seating.

- (b) Wherever, steam conditioning calls for Pressure reducing & desuperheating, combined PRDS type valves shall be offered.
- (c) Bidder shall provide redundant control valves for Main condensate flow control, Superheat attemperation control and Reheat attemperation control as a minimum for high availability. For other application, if the availability criteria for the plant cannot be met even with the best established product, redundant control valves shall be provided.
- (d) Control valves shall be located near floor or platform for ease of access and with adequate clearances for maintenance and lay-down and shall be placed as station with upstream motorized isolating valve, down-stream isolating valve, inching duty motorized bypass valve and manual drain valves. Each redundant control valve shall have its upstream motorized and down-stream manual isolating valves. Where quick shut off requirement is foreseen such as in case of SH & RH attemperation valves, upstream isolation valve shall be pneumatic type.

3.1 GENERAL

- 3.1.1 Control valves for regulating service shall normally be globe body, preferably cage guided, metal-to-metal seated, pneumatically operated and shall be provided with characterized plugs having ANSI leakage class-IV except for the control valves indicated above.
- 3.1.2 Where the operating time is critical for the operation of the plant, as in case of HP or LP bypass valves, hydraulic actuators with electro-hydraulic interface shall be offered.
- 3.1.3 Bonnet joints for all control valves shall be of flanged and bolted type.
- 3.1.4 Flanged valve shall be rated at no less than class 300 lbs.

 MAHAGENCO Maharashtra State Power Generation Co. Ltd.	MAHARASHTRA STATE POWER GENERATION CO. LTD.	Volume : V
	BID SPECIFICATION NO.:DG/BSL U-6/2011/T-1	Section – 5
REV: R0	CONTROL & INSTRUMENTATION	Page 295 of 718

3.2 VALVE BODY/END CONNECTIONS

3.2.1 Valve end to end dimension and connection shall be according to ANSI standard, straight through pattern. However, Bidder may offer angle body valve for high pressure drop applications. For high pressure drop applications, construction of the valve shall be such that the gland is not exposed to inlet pressure.

3.2.2 Control valves of 40 mm. size and above with line pressure up to 50 Kg/Sq. cm may have flanged or welded end connections.

3.2.3 Control valves, used in high pressure services shall have butt welded end connections for size 65mm and above and socket weld end connection for size 50 mm or below.

3.2.4 Control valve body shall be selected as per the ISA guideline. Generally control valve body shall be cast and machined for pressure rating up to 1500 lbs. Above 1500 lbs, valve body shall be of forged steel. For Demineralized Water application, valve body shall be Stainless Steel.

3.2.5 The direction of flow shall be clearly engraved on the body.

3.2.6 Valve Body Material

SR.NO.	SERVICE	MATERIAL
(a)	Non corrosive, non-flashing and non cavitating service for fluid temperature upto 275°C	: Cast carbon steel ASTM A216 Gr. WCB
(b)	Non corrosive, non-flashing and non cavitating service for fluid temperature above 275°C	: Cast alloy steel ASTM A217 Gr. WC9
(c)	Severe flashing / cavitating services	: Cast alloy steel ASTM A217 Gr. WC9
(d)	Low flashing / cavitating services	: Cast alloy steel ASTM A217 Gr. WC6

 MAHAGENCO <small>Maharashtra State Power Generation Co. Ltd.</small>	MAHARASHTRA STATE POWER GENERATION CO. LTD.	Volume : V						
	BID SPECIFICATION NO.:DG/BSL U-6/2011/T-1	Section – 5						
REV: R0	CONTROL & INSTRUMENTATION	Page 296 of 718						
<table border="0" style="width: 100%;"> <thead> <tr> <th style="text-align: left;">SR.NO.</th> <th style="text-align: left;">SERVICE</th> <th style="text-align: left;">MATERIAL</th> </tr> </thead> <tbody> <tr> <td>(e)</td> <td>DM water application (condenser hotwell normal, emergency make up etc.)</td> <td>: Cast type 316 stainless steel ASTM A351 Gr. CF8M</td> </tr> </tbody> </table>			SR.NO.	SERVICE	MATERIAL	(e)	DM water application (condenser hotwell normal, emergency make up etc.)	: Cast type 316 stainless steel ASTM A351 Gr. CF8M
SR.NO.	SERVICE	MATERIAL						
(e)	DM water application (condenser hotwell normal, emergency make up etc.)	: Cast type 316 stainless steel ASTM A351 Gr. CF8M						
3.3	<p><u>VALVE SIZE</u></p> <p>The control valve sizing (Cv/Kv) shall be based on following guidelines :</p> <p>(a) The valves shall pass normal flow (MCR condition) with 60 to 70 percent opening for linear characterized valves and between 70 to 80 percent opening for equal percentage characterized valves.</p> <p>(b) The valves shall have adequate rangeability to pass the minimum and maximum flows at 10% and 85% of the valve opening respectively. Valve stem travel range from minimum to maximum flow condition shall not be less than 50% of the total valve stem travel.</p> <p>(c) Valve CV shall be selected in such a way that the valve shall be capable of handling at least 120% of required maximum flow.</p> <p>(d) The valve selection shall be based on the highest size dictated by the above considerations unless noise, flashing or other factors dictate the final selection.</p> <p>(e) Trim outlet velocity for the control valves shall be no more than 7 m/sec for water service and Mach number less than 1/3 for steam and air service application.</p> <p>(f) The sizing procedure followed shall be as per latest edition of ANSI/ISA or equivalent standard.</p>							
3.4	<p><u>VALVE TOP WORK</u></p>							
3.4.1	<p>Top work shall be sized so that the valve shall operate properly when upstream pressure is 10 percent above maximum inlet pressure and downstream pressure is atmospheric.</p>							

 MAHAGENCO Maharashtra State Power Generation Co. Ltd.	MAHARASHTRA STATE POWER GENERATION CO. LTD.	Volume : V
	BID SPECIFICATION NO.:DG/BSL U-6/2011/T-1	Section – 5
REV: R0	CONTROL & INSTRUMENTATION	Page 297 of 718
3.4.2	Extended bonnet/Finned bonnet and high temperature packing shall be used for high temperature application.	
3.4.3	The gland material shall be chosen to suit the operating temperature. PTFE may be chosen for lower temperature application (232°C maximum) and for high temperature application graphite asbestos glands are to be provided. For vacuum services, the glands shall be of dry seal type.	
3.5	<u>VALVE TRIM</u>	
3.5.1	Valve trim for applications up to leakage class-V shall be stainless steel 316 SS for pressure drop up to 7 Kg/Sq. cm. For pressure drops above 7 Kg/Sq. cm hard trim (stelliting or equivalent) shall be used. Other alloys or treatment such as nitride shall be used if severe erosion is expected.	
3.5.2	Balanced trim valves shall be offered for high shut-off pressure or high pressure drop condition to reduce the size of the actuators.	
3.5.3	For flashing services and two stage mixtures, the trim material shall be 17-4 PH SS or equivalent.	
3.5.4	If cavitating condition is foreseen, Bidder shall offer multistage or labyrinth trim valves. Trim of severe service valves shall be of multistage and multipath design with number of discrete pressure drop stages to eliminate the chances of erosion, cavitation, noise and vibration throughout the control range of the valve.	
3.5.5	Quick replacement type trim shall be considered for easy maintenance.	
3.5.6	Trim Material	
	SR. NO.	SERVICE
		MATERIAL
	(a)	Non corrosive, non-flashing and non cavitating service for fluid temperature upto 275°C.
		: SS 316 stellited
	(b)	Non corrosive, non-flashing and non cavitating service for fluid
		: SS 316 stellited

 MAHAGENCO <small>Maharashtra State Power Generation Co. Ltd.</small>	MAHARASHTRA STATE POWER GENERATION CO. LTD.	Volume : V
	BID SPECIFICATION NO.:DG/BSL U-6/2011/T-1	Section – 5
REV: R0	CONTROL & INSTRUMENTATION	Page 298 of 718

SR. NO.	SERVICE	MATERIAL
----------------	----------------	-----------------

temperature above 275°C.

- | | | |
|-----|---|--------------|
| (c) | Severe flashing /cavitating services | : 440 C |
| (d) | Low flashing /cavitating services | : 17-4 PH SS |
| (e) | DM water application (condenser hotwell normal, emergency make up etc.) | : 17-4 PH SS |

3.6 NOISE LEVEL

The equivalent sound level measured at 1.5M above nearest floor level in elevation and 1 M horizontally from the control valve expressed in decibels to a reference of 0.0002 microbar shall not exceed 85 dB. If the calculated noise is more than the above limit, even with low noise trim design, diffusers shall be included. Diffusers shall be made of stainless steel and shall be integrally connected to the control valve with spool piece. The spool piece shall be in conformity with the main line piping specification.

3.7 VALVE ACTUATORS

Spring-diaphragm type actuators shall generally be used. Piston type actuators shall be offered in case of high shut-off pressure & quick response requirement.

- 3.7.1 The actuator shall be designed for 150% thrust required for the valve (at shut-off pressure) at an air line supply pressure of 5.5 Kg/Sq. cm.
- 3.7.2 Diaphragms shall be designed for 200% maximum operating pressure.
- 3.7.3 Nylon reinforced neoprene is preferred as diaphragm material.
- 3.7.4 Valve actuators shall be capable of operating at 80°C ambient, continuously.
- 3.7.5 Entire actuator assembly shall be painted with corrosion inhibiting paint.

 MAHAGENCO <small>Maharashtra State Power Generation Co. Ltd.</small>	MAHARASHTRA STATE POWER GENERATION CO. LTD.	Volume : V
	BID SPECIFICATION NO.:DG/BSL U-6/2011/T-1	Section – 5
REV: R0	CONTROL & INSTRUMENTATION	Page 299 of 718
3.7.6	Air connection size shall be ¼" NPT (F) unless otherwise dictated by process response time. Integral tubing shall be stainless steel.	
3.7.7	Bidder shall indicate the stroking time of the valve assemblies with positioner and ensure that the stroke time shall meet the process and equipment dynamics and shall be better than 20 seconds.	
3.7.8	All actuators shall be of fail safe design signifying that the spring direction will tend to move the valve (open or close) in a direction safe for the process. "Failure to Open" or "Failure to Close" shall be marked on the actuator.	
3.8	<u>VALVE POSITIONERS</u>	
3.8.1	Regulating duty valves shall be offered with SMART Electro Pneumatic Positioners to ensure accuracy and repeatability of response.	
3.8.2	Positioners shall have integral non contact type position transmitter, input and output gauges, local keypad & display.	
3.8.3	Positioners shall be capable of functioning under hot, humid and vibrating conditions.	
3.8.4	Positioner casings shall be dust tight, corrosion resistant and weatherproof.	
3.8.5	In general, positioner shall operate at signal range 4 - 20 mA DC for the full travel of the valve. Remote calibration from control room shall be possible through HART management station for main plant positioners. However the calibration of positioner of off-site plants shall be carried out from hand held station.	
3.9	<u>VALVE ACCESSORIES</u>	
	Accessories shall include side mounted hand wheels, limit switches, junction boxes, airlock relays etc.. Solenoid valve wherever required shall be furnished.	

 MAHAGENCO Maharashtra State Power Generation Co. Ltd.	MAHARASHTRA STATE POWER GENERATION CO. LTD.	Volume : V
	BID SPECIFICATION NO.:DG/BSL U-6/2011/T-1	Section – 5
REV: R0	CONTROL & INSTRUMENTATION	Page 269 of 718
SR. NO.	ITEM	DESCRIPTION
1.35.15	Stability	Less than 0.25% of Span / Zero for six months.
1.35.16	Cable connection	¾" ET.
1.35.17	Mounting	Field (pipe/wall mounting).
1.35.18	Accessories	Air filter regulator, mounting accessories, cable gland etc.
1.36	<u>AIR FILTER REGULATOR</u>	
1.36.1	Filter Element	Sintered Bronze.
1.36.2	Filter Size	5 microns.
1.36.3	Input Air	10.0 Kg/Sq. cm (maximum)
1.36.4	Output	Adjustable from 0-2.0 Kg / Sq. cm or 0-7.0 Kg/Sq. cm (continuous) as applicable for I/P converter, control drives and control valve.
1.36.5	Effect of Supply	Maximum 0.02 Kg/Sq. cm for a change pressure variation in supply pressure of 4 Kg/Sq. cm.
1.36.6	Bowl Material	Metallic cover around high temperature area/clear transparent polycarbonate with metallic cover for ordinary applications.
1.36.7	Accessories	2" dial size output pressure gauge.
1.36.8	Desirable Feature	No perceptible drop of pressure on opening the drain port.

CONSULTANT : PROCON ENGINEERS

 MAHAGENCO Maharashtra State Power Generation Co. Ltd.	MAHARASHTRA STATE POWER GENERATION CO. LTD.	Volume : V
	BID SPECIFICATION NO.:DG/BSL U-6/2011/T-1	Section – 5
REV: R0	CONTROL & INSTRUMENTATION	Page 270 of 718
SR. NO.	ITEM	DESCRIPTION
1.37	<u>SOLENOID VALVE</u>	
1.37.1	Operating Principle	Electromagnetic. (noiseless)
1.37.2	Coil voltage rating	24 V DC
1.37.3	Ways	Generally 3-ways other depending on requirement
1.37.4	Port size	1/4" NPT all ports.
1.37.5	Body	SS bar stock.
1.37.6	Trim	SS-316.
1.37.7	Duty	Suitable for continuous energization.
1.37.8	Sealing	Airtight and leak proof.
1.37.9	Ambient Temperature	0 - 50 ° C.
1.37.10	Fluid Temperature	0-150 ° C (approx.)
1.37.11	Coil Enclosure	Stainless Steel.
1.37.12	Insulation	Class-H.
1.37.13	Coil Casing	IP-65 (Explosion proof for NEC Class-1, Division-1 area)
1.37.14	Mounting	On pipe or on panel.
1.37.15	Cable Connection	3/4" ET.
1.37.16	Accessories	Mounting brackets, nuts and bolts.
1.37.17	Preferred feature	(a) Solenoid valve directly integral to actuator body shall have NAMOOR interface for uniformity.

CONSULTANT : PROCON ENGINEERS

 MAHAGENCO Maharashtra State Power Generation Co. Ltd.	MAHARASHTRA STATE POWER GENERATION CO. LTD.	Volume : V
	BID SPECIFICATION NO.:DG/BSL U-6/2011/T-1	Section – 5
REV: R0	CONTROL & INSTRUMENTATION	Page 247 of 718
SR. NO.	ITEM	DESCRIPTION
		drawing and Flow vs. DP curve.
1.17.7	Meter run pipe	Same as pipe material.
1.17.8	Accessories	Meter run pipe, nipples and root valves (Inspection port assembly for nozzles used in plant performance purpose).
1.18	<u>GAUGE GLASS</u>	
1.18.1	Type	Reflex.
1.18.2	Glass	Toughened borosilicate Resistant to mechanical and thermal shocks.
1.18.3	Body material	Carbon steel / stainless steel - As per process requirements (Flanged Connection).
1.18.4	Pressure rating	Twice the maximum working pressure.
1.18.5	Temperature rating	As required.
1.18.6	Bolts and nuts	Rust proof alloy steel.
1.18.7	Accessories	Suitable ball check valves of SS-304 /316 body, gaskets, companion flange etc.
1.19	<u>POWER CYLINDERS (PNEUMATIC)</u>	
1.19.1	Mounting Type	(a) Fixed position mounting. (End mounting)
		(b) Trunnion mounting.
1.19.2	Control Signal	4-20 mA DC to SMART positioner with Superimposed HART protocol for

CONSULTANT : PROCON ENGINEERS

 MAHAGENCO Maharashtra State Power Generation Co. Ltd.	MAHARASHTRA STATE POWER GENERATION CO. LTD.	Volume : V
	BID SPECIFICATION NO.:DG/BSL U-6/2011/T-1	Section – 5
REV: R0	CONTROL & INSTRUMENTATION	Page 248 of 718
SR. NO.	ITEM	DESCRIPTION
		modulating purposes. 24V DC operated solenoid valve operating on pneumatic line for open & closing purpose of on & off drive.
1.19.3	Supply Air	7 Kg / cm ² .
1.19.4	Selection	Based upon thrust/torque, stroke length, angular movement, full-scale travel time, repeatability, space factor etc Provision for air-to-open and air-to-close operation.
1.19.5	Casing	IP-65.
1.19.6	Accessories	(a) Air lock relay.
		(b) Hand wheel.
		(c) Air filter regulator with gauge.
		(d) Volume Booster.
		(e) Limit Switches.
		(f) Smart Positioner with Input and Output pressure gauges, local keypad & display.
		(g) Solenoid Valve.
		(h) Integral non contact type position Transmitter. (4-20 mA DC linear output)
		(i) Junction box with cable gland.
1.19.7	Fail-safe operation	For regulating duty- stay put against

CONSULTANT : PROCON ENGINEERS

 MAHAGENCO Maharashtra State Power Generation Co. Ltd.	MAHARASHTRA STATE POWER GENERATION CO. LTD.	Volume : V
	BID SPECIFICATION NO.:DG/BSL U-6/2011/T-1	Section – 5
REV: R0	CONTROL & INSTRUMENTATION	Page 249 of 718
SR. NO.	ITEM	DESCRIPTION
		power & air fail.
1.19.8	Repeatability	Better than 0.5% of full travel.
1.19.9	Hysteresis	Less than $\pm 1\%$ of full travel.
1.19.10	Operating Temp. limit	80 Deg. C (min.)
1.20	<u>SMOKE DENSITY ANALYZER</u>	
1.20.1	Type	Insitu dry visible light. (through LED)
1.20.2	Principle of measurement	Transmission & absorption. (Dual beam type)
1.20.3	Light source	Modulated high intensity LED.
1.20.4	Display	Back Lit LCD.
1.20.5	Measurement range	0-999 mg/m ³ , 0-999 mg/Nm ³ , 0-100% Opacity.
1.20.6	Measurement averaging	Selectable 10 sec to 60 minutes.
1.20.7	Accuracy	0.2% opacity.
1.20.8	Resolution	0.1% opacity.
1.20.9	Linearity	0.1% opacity.
1.20.10	Repeatability	0.1% opacity.
1.20.11	Flue gas temperature	350 °C (max 600 °C).
1.20.12	Ambient temperature	0 - 60 °C.
1.20.13	Operating temperature	Transmitter & receiver - 0-90°C, Electronic unit - 70 °C.

CONSULTANT : PROCON ENGINEERS



Technical specification for
Control Valves with Accessories
(Pneumatically Operated)

SPEC NO.: PE-TS-415-145-I801

DOCUMENT NO.

VOLUME II B

SECTION C

ISSUE NO. 2

REV. NO. 00

DATE 10.01.2020

SECTION-C

DATASHEET A&B

BHEL PEM	DOCUMENT TITLE	DOCUMENT NUMBER PE-TS-415-145-I801
	DATA SHEET FOR CONTROL VALVES	REVISION 00 DATE 10.10.2020 NUMBER
	1x660 MW BHUSAWAL STPP	SHEET 1 OF 50

Notes:

1. All general technical requirements including material & construction, leakage class, body sizing and Cv sizing etc. shall be as per customer specifications.
2. Type of bonnet shall be according to the service condition. Extension bonnets shall be provided when the maximum temperature of the flowing fluid is greater than 280 °C.
3. If the downstream is subjected to vacuum, flow direction of the fluid shall be to close. Separate indication for the same has not been made in the data sheet.
4. Valve and actuator shall be designed for full differential pressure (Max. shut-off pressure).
5. Mandatory spares for control valves, shall be as per contractual agreement with customer.
6. Testing & other requirements shall be as per customer's specifications.
7. Quantity indicated is for one unit.
8. Tolerances on end to end, center to center, center to face shall be in accordance with ASME B16.10.
9. In addition to tag nos. CDV-22 & CDV-39, anti cavitation trim to be provided for valves subjected to cavitation as per service conditions.
10. **Noise level for control valve shall be inline with the tender specification clause no. 3.6 of Vol-V, Section-6.**

BHEL PEM	DOCUMENT TITLE	DOCUMENT NUMBER	PE-TS-415-145-I801
	DATA SHEET FOR CONTROL VALVES	REVISION NUMBER	00 DATE 10.10.2020
	1x660 MW BHUSAWAL STPP	SHEET	2 OF 50

INDEX

S.No.	SERVICE	Qty. / Unit	Qty. for Station
1.	D/A Pegging from Aux. Steam Header (ASV-8)	01	01
2.	D/A Pegging from CRH Line (CRHV-6)	01	01
3.	Main Condensate Control (CDV-22)	01	01
4.	Main Condensate Control (CDV-25)	01	01
5.	GSC & CEP min. flow recirculation (CDV-39)	01	01
6.	Excess Dump Control (CDV-43)	01	01
7.	Condensate for Valve Gland Sealing (CDV-72)	01	01
8.	HPH-7 Drain to HPH-6 (DRV-8)	01	01
9.	HPH-7 ALT Drain to Flash tank B(DRV-11)	01	01
10.	HPH-6 Drain to Deaerator (DRV-15)	01	01
11.	HPH-6 Drain to Flash tank-A (DRV-18)	01	01
12.	LPH-3 Drain to LPH-2 (DRV-28)	01	01
13.	LPH-3 Drain to Flash tank-B (DRV-31)	01	01
14.	LPH-2 Drain to LPH-1 (DRV-34)	01	01
15.	LPH-2 Drain to Flash Tank-B (DRV-37)	01	01
16.	Deaerator overflow to Flash tank-B (DRV-48)	01	01
17.	HPH-8 drain to HPH-7 (DRV-2)	01	01
18.	HPH-8 alternate drain to Flash Tank-A (DRV-5)	01	01
19.	LPH-4 Drain to LPH-3 (DRV-65)	01	01
20.	LPH-4 Alternate drain to Flash Tank-B (DRV-68)	01	01
21.	DM MU to Hotwell High Capacity (DMV-50)	01	01
22.	DM MU to Hotwell Low Capacity (DMV-47)	01	01
23.	Low Load Feed Control (FDV-14)	01	01
24.	Auxiliary Steam to BFPT (ASV-2)	01	01
25.	CRH to BFPT (CRHV-2)	01	01

BHEL PEM		DATA SHEET FOR CONTROL VALVES (WITH PNEUMATIC ACTUATOR)		SPECIFICATION NO.: PE-TS-415-145-I801	
				VOLUME	
		SECTION			
		REV. NO.	00	DATE	:10.01.2020
		SHEET	3	OF	50
Tag No. :...ASV-8... Qty.: ...1 per Unit ... PID NO: PE-DG-415-100-N103			Date Sheet No. PES-145-06-DS1-0		
DATA SHEET – A & B					
DATA SHEET – A FOR CONTROL VALVE (WITH PNEUMATIC ACTUATOR) (TO BE FILLED BY PURCHASER)				DATA SHEET – B (TO BE FILLED UP BY BIDDER)	
GENERAL*	PROJECT	1X660 MW BHUSAWAL TPS		
	SERVICE	D/A PEGGING FROM AUX. STEAM HEADER		
LOCATION	DUTY	<input checked="" type="checkbox"/> INDOOR	<input type="checkbox"/> OUTDOOR	
	PIPE SIZE (inlet / outlet)	<input type="checkbox"/> ON/OFF	<input checked="" type="checkbox"/> MODULATING	
PIPE MATERIAL (inlet / outlet)	PIPE SIZE (inlet / outlet)	219.1 x 6.35	559 x 10	
	PIPE MATERIAL (inlet / outlet)	SA 106 GR B	SA 672 GR B70	
BODY*	MODEL NO.	BIDDER TO SPECIFY		
	TYPE OF BODY: GUIDING : NO. OF PORTS	<input checked="" type="checkbox"/> GLOBE <input type="checkbox"/> ANGLE <input type="checkbox"/> TOP <input checked="" type="checkbox"/> CAGE ONE		
	BODY SIZE: PORT SIZE: DESIGN CV	BIDDER TO SPECIFY		
	END CONNECTION & RATING (ANSI)	<input checked="" type="checkbox"/> BWE <input type="checkbox"/> SWE <input type="checkbox"/> FLANGED		
	BODY MATERIAL	<input type="checkbox"/> A216 WCB <input checked="" type="checkbox"/> A217 WC9 <input type="checkbox"/> SS <input type="checkbox"/> A217 CS		
		<input type="checkbox"/> A351 CF8M		
	PACKING: MATERIAL SINGLE / DOUBLE	<input type="checkbox"/> PTFE <input checked="" type="checkbox"/> GRAFOIL <input type="checkbox"/> DOUBLE <input checked="" type="checkbox"/> SINGLE		
	BONNET TYPE	<input type="checkbox"/> STD <input type="checkbox"/> EXTENDED <input type="checkbox"/> FINNED		
	TRIM FORM	<input checked="" type="checkbox"/> LINEAR <input type="checkbox"/> EQ. PERCENTAGE		
		<input type="checkbox"/> QUICK OPEN (ON/OFF)		
TRIM MATERIAL: SEAT PLUG : CAGE GUIDE BUSH	SS 316 STELLITED SS 316 STELLITED			
	SS 316 STELLITED SS 316 STELLITED			
FLOW	BIDDER TO SPECIFY			
OUTLET VELOCITY	<input type="checkbox"/> < 7 M/SEC(WATER) <input checked="" type="checkbox"/> MAC NO. < 1/3 (STM)			
REQUIRED LEAKAGE CLASS	<input type="checkbox"/> II <input type="checkbox"/> III <input checked="" type="checkbox"/> IV <input type="checkbox"/> V <input type="checkbox"/> VI			
NOISE LEVEL (dBA)	LESS THAN 85 dBA			
VACUUM SERVICE	<input type="checkbox"/> YES <input checked="" type="checkbox"/> NO			
ANTI CAVITATION TRIM	<input type="checkbox"/> YES <input checked="" type="checkbox"/> NO			
PNEUMATIC ACTUATOR	MODEL NO. & SIZE	BIDDER TO SPECIFY		
	CLOSE AT : OPEN AT (KG/CM2g)	TO SUIT ACTUATOR'S DESIGN (AIR TO CLOSE)		
	*TRAVEL TIME FOR OPEN TO CLOSE, CLOSE TO OPEN	< 10 SEC		
	*VALVE POSN. ON SIGNAL AIR FAILURE	<input checked="" type="checkbox"/> TO OPEN <input type="checkbox"/> STAYPUT <input type="checkbox"/> TO CLOSE		
*VALVE POSN. ON SUPPLY AIR FAILURE	<input checked="" type="checkbox"/> STAYPUT			
ACCESSORIES	POSITIONER (SMART TYPE)	<input checked="" type="checkbox"/> REQUIRED <input type="checkbox"/> NOT REQUIRED		
	AIR FILTER REGULATOR	<input checked="" type="checkbox"/> REQUIRED <input type="checkbox"/> NOT REQUIRED		
	AIR LOCK RELAY	<input checked="" type="checkbox"/> REQUIRED <input type="checkbox"/> NOT REQUIRED		
	POSITION LIMIT SWITCH	<input checked="" type="checkbox"/> REQUIRED <input type="checkbox"/> NOT REQUIRED		
	POSITION TRANSMITTER	PART OF POSITIONER		
	SOLENOID VALVE	<input checked="" type="checkbox"/> REQUIRED <input type="checkbox"/> NOT REQUIRED		
	E/P CONVERTER	PART OF POSITIONER		
	JUNCTION BOX	<input checked="" type="checkbox"/> REQUIRED <input type="checkbox"/> NOT REQUIRED		
	HAND WHEEL (SIDE MOUNTED)	<input checked="" type="checkbox"/> REQUIRED		
LOCAL POSITION INDICATOR	<input checked="" type="checkbox"/> REQUIRED			

BHEL PEM	DATA SHEET FOR CONTROL VALVES (WITH PNEUMATIC ACTUATOR)	SPECIFICATION NO.: PE-TS-415-145-1801	
		VOLUME	
		SECTION	
		REV. NO. 00	DATE :10.01.2020
		SHEET 5	OF 50

Tag No. :...CRHV-6... Qty.: ...1 per Unit ...
 PID NO: PE-DG-415-100-N103

Date Sheet No. PES-145-06-DS1-0

DATA SHEET – A & B

DATA SHEET – A FOR CONTROL VALVE (WITH PNEUMATIC ACTUATOR) (TO BE FILLED BY PURCHASER)	DATA SHEET – B (TO BE FILLED UP BY BIDDER)
---	---

GENERAL*	PROJECT SERVICE LOCATION DUTY PIPE SIZE (inlet / outlet) PIPE MATERIAL (inlet / outlet)	1X660 MW BHUSAWAL TPS D/A PEGGING FROM CRH LINE <input checked="" type="checkbox"/> INDOOR <input type="checkbox"/> OUTDOOR <input type="checkbox"/> ON/OFF <input checked="" type="checkbox"/> MODULATING 355.6 x 15.09 965 x 34 SA 106 GR C SA 106 GR C
----------	--	---	--

BODY*	MODEL NO. TYPE OF BODY: GUIDING : NO. OF PORTS BODY SIZE: PORT SIZE: DESIGN CV END CONNECTION & RATING (ANSI) BODY MATERIAL PACKING: MATERIAL SINGLE / DOUBLE BONNET TYPE TRIM FORM TRIM MATERIAL: SEAT PLUG : CAGE GUIDE BUSH FLOW OUTLET VELOCITY REQUIRED LEAKAGE CLASS NOISE LEVEL (dBA) VACUUM SERVICE ANTI CAVITATION TRIM	BIDDER TO SPECIFY <input checked="" type="checkbox"/> GLOBE <input type="checkbox"/> ANGLE <input type="checkbox"/> TOP <input checked="" type="checkbox"/> CAGE ONE BIDDER TO SPECIFY <input checked="" type="checkbox"/> BWE <input type="checkbox"/> SWE <input type="checkbox"/> FLANGED <input type="checkbox"/> A216 WCB <input checked="" type="checkbox"/> A217 WC9 <input type="checkbox"/> SS <input type="checkbox"/> A217 CS <input type="checkbox"/> A351 CF8M <input type="checkbox"/> PTFE <input checked="" type="checkbox"/> GRAFOIL <input type="checkbox"/> DOUBLE <input checked="" type="checkbox"/> SINGLE <input type="checkbox"/> STD <input type="checkbox"/> EXTENDED <input type="checkbox"/> FINNED <input checked="" type="checkbox"/> LINEAR <input type="checkbox"/> EQ. PERCENTAGE <input type="checkbox"/> QUICK OPEN (ON/OFF) SS 316 STELLITED SS 316 STELLITED SS 316 STELLITED SS 316 STELLITED BIDDER TO SPECIFY <input type="checkbox"/> < 7 M/SEC (WATER) <input checked="" type="checkbox"/> MAC NO. < 1/3(STM) <input type="checkbox"/> II <input type="checkbox"/> III <input checked="" type="checkbox"/> IV <input type="checkbox"/> V <input type="checkbox"/> VI LESS THAN 85 dBA <input type="checkbox"/> YES <input checked="" type="checkbox"/> NO <input type="checkbox"/> YES <input checked="" type="checkbox"/> NO
-------	---	--	---

PNEUMATIC ACTUATOR	MODEL NO. & SIZE CLOSE AT : OPEN AT (KG/CM2g) *TRAVEL TIME FOR OPEN TO CLOSE, CLOSE TO OPEN *VALVE POSN. ON SIGNAL AIR FAILURE *VALVE POSN. ON SUPPLY AIR FAILURE	BIDDER TO SPECIFY TO SUIT ACTUATOR'S DESIGN(AIR TO OPEN) < 10 SEC <input type="checkbox"/> TO OPEN <input type="checkbox"/> STAYPUT <input checked="" type="checkbox"/> TO CLOSE <input checked="" type="checkbox"/> STAYPUT
--------------------	--	--	--

ACCESSORIES	POSITIONER (SMART TYPE) AIR FILTER REGULATOR AIR LOCK RELAY POSITION LIMIT SWITCH POSITION TRANSMITTER SOLENOID VALVE E/P CONVERTER JUNCTION BOX HAND WHEEL (SIDE MOUNTED) LOCAL POSITION INDICATOR	<input checked="" type="checkbox"/> REQUIRED <input type="checkbox"/> NOT REQUIRED <input checked="" type="checkbox"/> REQUIRED <input type="checkbox"/> NOT REQUIRED <input checked="" type="checkbox"/> REQUIRED <input type="checkbox"/> NOT REQUIRED <input checked="" type="checkbox"/> REQUIRED <input type="checkbox"/> NOT REQUIRED PART OF POSITIONER <input checked="" type="checkbox"/> REQUIRED <input type="checkbox"/> NOT REQUIRED PART OF POSITIONER <input checked="" type="checkbox"/> REQUIRED <input type="checkbox"/> NOT REQUIRED <input checked="" type="checkbox"/> REQUIRED <input checked="" type="checkbox"/> REQUIRED
-------------	--	--	---

BHEL PEM	DATA SHEET FOR CONTROL VALVES (WITH PNEUMATIC ACTUATOR)						SPECIFICATION NO.: PE-TS-415-145-1801			
							VOLUME			
							SECTION			
							REV. NO.	00	DATE	:10.01.2020
SHEET		8	OF		50					
Tag No. : CDV-22 & CDV-25 Qty.: 2 per Unit (One against each Tag No.) Date Sheet No. PES-145-06-DS1-0										
DATA SHEET – A & B										
DATA SHEET – A FOR CONTROL VALVE (WITH PNEUMATIC ACTUATOR) (TO BE FILLED BY PURCHASER)								DATA SHEET – B (TO BE FILLED UP BY BIDDER)		
PERFORMANCE OF VALVE	LINEARITY HYSTERISIS SENSITIVITY ACCURACY (OVERALL)			± 1% ± 1% ± 0.5% ± 2%					
SERVICE CONDITION*	SL. No. +	LOAD	FLOW (T/HR)	INLET PR. KG/CM2(A)	OUTLET PR. KG/CM2(A)	TEMP DEG (C)	CALC ULATED CV	% VLV LIFT	VLV O/L VELOCITY	
	1.	60% LOAD	849	34.1	13.4	44.1				
	2.	100% MCR	1434	31.0	21.3	49.0				
	3.	VWO	1533	30.35	22.9	49.8				
	4.	MIN. (10% LOAD)	142	35.1	6.5	46.3				
	VALVE TYPE						<input type="checkbox"/> CAVITATION <input type="checkbox"/> FLASHING <input checked="" type="checkbox"/> HIGH DP			
* MAX SHUT OFF PRESS (KG/CM2g) 47 * BODY DESIGN : PRESS (KG/CM2g) TEMP (DEG C) 47 60 * IBR FORM III-C <input type="checkbox"/> REQUIRED <input checked="" type="checkbox"/> NOT REQUIRED									
TOTAL WEIGHT (VALVE + ACTUATOR + ACCESSORIES) Kg									
NOTES:										
1. + DESIGN CV SHALL BE BASED ON SERVICE CONDITIONS INDICATED AT SL. NO. <u>3</u> .										

BHEL PEM	DATA SHEET FOR CONTROL VALVES (WITH PNEUMATIC ACTUATOR)	SPECIFICATION NO.: PE-TS-415-145-I801	
		VOLUME	
		SECTION	
		REV. NO. 00	DATE :10.01.2020
		SHEET 9	OF 50
Tag No. :...CDV-39... Qty.: ...1 per Unit ... PID NO: PE-DG-415-100-N106		Date Sheet No. PES-145-06-DS1-0	
DATA SHEET – A & B			
DATA SHEET – A FOR CONTROL VALVE (WITH PNEUMATIC ACTUATOR) (TO BE FILLED BY PURCHASER)			DATA SHEET – B (TO BE FILLED UP BY BIDDER)
GENERAL*	PROJECT SERVICE LOCATION DUTY PIPE SIZE (inlet / outlet) PIPE MATERIAL (inlet / outlet)	1X660 MW BHUSAWAL TPS GSC MIN. FLOW RECIRCULATION <input checked="" type="checkbox"/> INDOOR <input type="checkbox"/> OUTDOOR <input type="checkbox"/> ON/OFF <input checked="" type="checkbox"/> MODULATING 219.1 x 8.18 219.1 x 8.18 SA 106 GR C SA 106 GR C
BODY*	MODEL NO. TYPE OF BODY: GUIDING : NO. OF PORTS BODY SIZE: PORT SIZE: DESIGN CV END CONNECTION & RATING (ANSI) BODY MATERIAL PACKING: MATERIAL SINGLE / DOUBLE BONNET TYPE TRIM FORM TRIM MATERIAL: SEAT PLUG : CAGE GUIDE BUSH FLOW OUTLET VELOCITY REQUIRED LEAKAGE CLASS NOISE LEVEL (dBA) VACUUM SERVICE ANTI CAVITATION TRIM	BIDDER TO SPECIFY <input checked="" type="checkbox"/> GLOBE <input type="checkbox"/> ANGLE <input type="checkbox"/> TOP <input checked="" type="checkbox"/> CAGE ONE BIDDER TO SPECIFY <input checked="" type="checkbox"/> BWE <input type="checkbox"/> SWE <input type="checkbox"/> FLANGED <input type="checkbox"/> A216 WCB <input checked="" type="checkbox"/> A217 WC6 <input type="checkbox"/> SS <input type="checkbox"/> A217 CS <input type="checkbox"/> A351 CF8M <input type="checkbox"/> PTFE <input checked="" type="checkbox"/> GRAFOIL <input checked="" type="checkbox"/> DOUBLE <input type="checkbox"/> SINGLE <input type="checkbox"/> STD <input type="checkbox"/> EXTENDED <input type="checkbox"/> FINNED <input checked="" type="checkbox"/> LINEAR <input type="checkbox"/> EQ. PERCENTAGE <input type="checkbox"/> QUICK OPEN (ON/OFF) 17-4 PH SS 17-4 PH SS 17-4 PH SS 17-4 PH SS BIDDER TO SPECIFY <input checked="" type="checkbox"/> < 7 M/SEC (WATER) <input type="checkbox"/> MAC NO. < 1/3(STM) <input type="checkbox"/> II <input type="checkbox"/> III <input type="checkbox"/> IV <input checked="" type="checkbox"/> V <input type="checkbox"/> VI LESS THAN 85 dBA <input checked="" type="checkbox"/> YES <input type="checkbox"/> NO <input checked="" type="checkbox"/> YES <input type="checkbox"/> NO
PNEUMATIC ACTUATOR	MODEL NO. & SIZE CLOSE AT : OPEN AT (KG/CM2g) *TRAVEL TIME FOR OPEN TO CLOSE, CLOSE TO OPEN *VALVE POSN. ON SIGNAL AIR FAILURE *VALVE POSN. ON SUPPLY AIR FAILURE	BIDDER TO SPECIFY TO SUIT ACTUATOR'S DESIGN(AIR TO CLOSE) < 10 SEC <input checked="" type="checkbox"/> TO OPEN <input type="checkbox"/> STAYPUT <input type="checkbox"/> TO CLOSE <input checked="" type="checkbox"/> STAYPUT
ACCESSORIES	POSITIONER (SMART TYPE) AIR FILTER REGULATOR AIR LOCK RELAY POSITION LIMIT SWITCH POSITION TRANSMITTER SOLENOID VALVE E/P CONVERTER JUNCTION BOX HAND WHEEL (SIDE MOUNTED) LOCAL POSITION INDICATOR	<input checked="" type="checkbox"/> REQUIRED <input type="checkbox"/> NOT REQUIRED <input checked="" type="checkbox"/> REQUIRED <input type="checkbox"/> NOT REQUIRED <input checked="" type="checkbox"/> REQUIRED <input type="checkbox"/> NOT REQUIRED <input checked="" type="checkbox"/> REQUIRED <input type="checkbox"/> NOT REQUIRED PART OF POSITIONER <input checked="" type="checkbox"/> REQUIRED <input type="checkbox"/> NOT REQUIRED PART OF POSITIONER <input checked="" type="checkbox"/> REQUIRED <input type="checkbox"/> NOT REQUIRED <input checked="" type="checkbox"/> REQUIRED <input checked="" type="checkbox"/> REQUIRED

BHEL PEM	DATA SHEET FOR CONTROL VALVES (WITH PNEUMATIC ACTUATOR)	SPECIFICATION NO.: PE-TS-415-145-1801	
		VOLUME	
		SECTION	
		REV. NO. 00	DATE :10.01.2020
		SHEET 11	OF 50
Tag No. :...CDV-43... Qty.: ...1 per Unit ... PID NO: PE-DG-415-100-N106		Date Sheet No. PES-145-06-DS1-0	
DATA SHEET – A & B			
DATA SHEET – A FOR CONTROL VALVE (WITH PNEUMATIC ACTUATOR) (TO BE FILLED BY PURCHASER)			DATA SHEET – B (TO BE FILLED UP BY BIDDER)
GENERAL*	PROJECT SERVICE LOCATION DUTY PIPE SIZE (inlet / outlet) PIPE MATERIAL (inlet / outlet)	1X660 MW BHUSAWAL TPS EXCESS RETURN TO CST <input checked="" type="checkbox"/> INDOOR <input type="checkbox"/> OUTDOOR <input type="checkbox"/> ON/OFF <input checked="" type="checkbox"/> MODULATING 219.1 x 8.18 219.1 x 6.35 SA 106 GR C SA 106 GR B
BODY*	MODEL NO. TYPE OF BODY: GUIDING : NO. OF PORTS BODY SIZE: PORT SIZE: DESIGN CV END CONNECTION & RATING (ANSI) BODY MATERIAL PACKING: MATERIAL SINGLE / DOUBLE BONNET TYPE TRIM FORM TRIM MATERIAL: SEAT PLUG : CAGE GUIDE BUSH FLOW OUTLET VELOCITY REQUIRED LEAKAGE CLASS NOISE LEVEL (dBA) VACUUM SERVICE ANTI CAVITATION TRIM	BIDDER TP SPECIFY <input type="checkbox"/> GLOBE <input checked="" type="checkbox"/> ANGLE <input type="checkbox"/> TOP <input checked="" type="checkbox"/> CAGE ONE BODDER TO SPECIFY <input checked="" type="checkbox"/> BWE <input type="checkbox"/> SWE <input type="checkbox"/> FLANGED <input type="checkbox"/> A216 WCB <input checked="" type="checkbox"/> A217 WC6 <input type="checkbox"/> SS <input type="checkbox"/> A217 CS <input type="checkbox"/> A351 CF8M <input type="checkbox"/> PTFE <input checked="" type="checkbox"/> GRAFOIL <input type="checkbox"/> DOUBLE <input checked="" type="checkbox"/> SINGLE <input type="checkbox"/> STD <input type="checkbox"/> EXTENDED <input type="checkbox"/> FINNED <input checked="" type="checkbox"/> LINEAR <input type="checkbox"/> EQ. PERCENTAGE <input type="checkbox"/> QUICK OPEN (ON/OFF) 17-4 PH SS 17-4 PH SS 17-4 PH SS 17-4 PH SS BIDDER TO SPECIFY <input checked="" type="checkbox"/> < 7 M/SEC (WATER) <input type="checkbox"/> MAC NO. < 1/3(STM) <input type="checkbox"/> II <input type="checkbox"/> III <input type="checkbox"/> IV <input checked="" type="checkbox"/> V <input type="checkbox"/> VI LESS THAN 85 dBA <input type="checkbox"/> YES <input checked="" type="checkbox"/> NO <input checked="" type="checkbox"/> YES <input type="checkbox"/> NO
PNEUMATIC ACTUATOR	MODEL NO. & SIZE CLOSE AT : OPEN AT (KG/CM2g) *TRAVEL TIME FOR OPEN TO CLOSE, CLOSE TO OPEN *VALVE POSN. ON SIGNAL AIR FAILURE *VALVE POSN. ON SUPPLY AIR FAILURE	BIDDER TO SPECIFY TO SUIT ACTUATOR'S DESIGN(AIR TO CLOSE) < 10 SEC <input checked="" type="checkbox"/> TO OPEN <input type="checkbox"/> STAYPUT <input type="checkbox"/> TO CLOSE <input checked="" type="checkbox"/> STAYPUT
ACCESSORI ES	POSITIONER (SMART TYPE) AIR FILTER REGULATOR AIR LOCK RELAY POSITION LIMIT SWITCH POSITION TRANSMITTER SOLENOID VALVE E/P CONVERTER JUNCTION BOX HAND WHEEL (SIDE MOUNTED) LOCAL POSITION INDICATOR	<input checked="" type="checkbox"/> REQUIRED <input type="checkbox"/> NOT REQUIRED <input checked="" type="checkbox"/> REQUIRED <input type="checkbox"/> NOT REQUIRED <input checked="" type="checkbox"/> REQUIRED <input type="checkbox"/> NOT REQUIRED <input checked="" type="checkbox"/> REQUIRED <input type="checkbox"/> NOT REQUIRED PART OF POSITIONER <input checked="" type="checkbox"/> REQUIRED <input type="checkbox"/> NOT REQUIRED PART OF POSITIONER <input checked="" type="checkbox"/> REQUIRED <input type="checkbox"/> NOT REQUIRED <input checked="" type="checkbox"/> REQUIRED <input checked="" type="checkbox"/> REQUIRED

BHEL PEM	DATA SHEET FOR CONTROL VALVES (WITH PNEUMATIC ACTUATOR)		SPECIFICATION NO.: PE-TS-415-145-1801			
			VOLUME			
			SECTION			
			REV. NO.	00	DATE	:10.01.2020
			SHEET	13	OF	50
Tag No. :...CDV-72... Qty.: ...1 per Unit ...		Date Sheet No. PES-145-06-DS1-0				
PID NO: PE-DG-415-100-N106						
DATA SHEET – A & B						
DATA SHEET – A FOR CONTROL VALVE (WITH PNEUMATIC ACTUATOR) (TO BE FILLED BY PURCHASER)				DATA SHEET – B (TO BE FILLED UP BY BIDDER)		
GENERAL*	PROJECT SERVICE	1X660 MW BHUSAWAL TPS			
	LOCATION	CONDENSATE FOR VALVE GLAND SEALING			
GENERAL*	DUTY	<input checked="" type="checkbox"/> INDOOR <input type="checkbox"/> OUTDOOR			
	PIPE SIZE (inlet / outlet)	<input type="checkbox"/> ON/OFF <input checked="" type="checkbox"/> MODULATING			
GENERAL*	PIPE MATERIAL (inlet / outlet)	60.3 x 5.54 60.3 x 5.54			
		SA 106 GR B SA 106 GR B			
BODY*	MODEL NO.	BIDDER TO SPECIFY			
	TYPE OF BODY: GUIDING : NO. OF PORTS	<input checked="" type="checkbox"/> GLOBE <input type="checkbox"/> ANGLE <input type="checkbox"/> TOP <input checked="" type="checkbox"/> CAGE ONE			
	BODY SIZE: PORT SIZE: DESIGN CV	BIDDER TO SPECIFY			
	END CONNECTION & RATING (ANSI)	<input checked="" type="checkbox"/> BWE <input type="checkbox"/> SWE <input type="checkbox"/> FLANGED			
	BODY MATERIAL	<input checked="" type="checkbox"/> A216 WCB <input type="checkbox"/> A217 WC6 <input type="checkbox"/> SS <input type="checkbox"/> A217 CS			
		<input type="checkbox"/> A351 CF8M			
	PACKING: MATERIAL SINGLE / DOUBLE	<input type="checkbox"/> PTFE <input checked="" type="checkbox"/> GRAFOIL <input type="checkbox"/> DOUBLE <input checked="" type="checkbox"/> SINGLE			
	BONNET TYPE	<input type="checkbox"/> STD <input type="checkbox"/> EXTENDED <input type="checkbox"/> FINNED			
	TRIM FORM	<input type="checkbox"/> LINEAR <input checked="" type="checkbox"/> EQ. PERCENTAGE			
		<input type="checkbox"/> QUICK OPEN (ON/OFF)			
BODY*	TRIM MATERIAL: SEAT PLUG	SS 316 STELLITED SS 316 STELLITED			
	: CAGE GUIDE BUSH	SS 316 STELLITED SS 316 STELLITED			
	FLOW	BIDDER TO SPECIFY			
	OUTLET VELOCITY	<input checked="" type="checkbox"/> < 7 M/SEC (WATER) <input type="checkbox"/> MAC NO. < 1/3(STM)			
	REQUIRED LEAKAGE CLASS	<input type="checkbox"/> II <input type="checkbox"/> III <input checked="" type="checkbox"/> IV <input type="checkbox"/> V <input type="checkbox"/> VI			
	NOISE LEVEL (dBA)	LESS THAN 85 dBA			
	VACUUM SERVICE	<input type="checkbox"/> YES <input checked="" type="checkbox"/> NO			
	ANTI CAVITATION TRIM	<input type="checkbox"/> YES <input checked="" type="checkbox"/> NO			
	PNEUMATIC ACTUATOR	MODEL NO. & SIZE	BIDDER TO SPECIFY		
		CLOSE AT : OPEN AT (KG/CM2g)	TO SUIT ACTUATOR'S DESIGN(AIR TO CLOSE)		
*TRAVEL TIME FOR OPEN TO CLOSE, CLOSE TO OPEN		< 10 SEC			
*VALVE POSN. ON SIGNAL AIR FAILURE		<input checked="" type="checkbox"/> TO OPEN <input type="checkbox"/> STAYPUT <input type="checkbox"/> TO CLOSE			
ACCESSORIES	*VALVE POSN. ON SUPPLY AIR FAILURE	<input checked="" type="checkbox"/> STAYPUT			
	POSITIONER (SMART TYPE)	<input checked="" type="checkbox"/> REQUIRED <input type="checkbox"/> NOT REQUIRED			
	AIR FILTER REGULATOR	<input checked="" type="checkbox"/> REQUIRED <input type="checkbox"/> NOT REQUIRED			
	AIR LOCK RELAY	<input checked="" type="checkbox"/> REQUIRED <input type="checkbox"/> NOT REQUIRED			
	POSITION LIMIT SWITCH	<input checked="" type="checkbox"/> REQUIRED <input type="checkbox"/> NOT REQUIRED			
	POSITION TRANSMITTER	PART OF POSITIONER			
	SOLENOID VALVE	<input checked="" type="checkbox"/> REQUIRED <input type="checkbox"/> NOT REQUIRED			
	E/P CONVERTER	PART OF POSITIONER			
	JUNCTION BOX	<input checked="" type="checkbox"/> REQUIRED <input type="checkbox"/> NOT REQUIRED			
	HAND WHEEL (SIDE MOUNTED)	<input checked="" type="checkbox"/> REQUIRED			
LOCAL POSITION INDICATOR	<input checked="" type="checkbox"/> REQUIRED				

BHEL PEM		DATA SHEET FOR CONTROL VALVES (WITH PNEUMATIC ACTUATOR)		SPECIFICATION NO.: PE-TS-415-145-I801	
				VOLUME	
				SECTION	
				REV. NO.	00
		SHEET	15	OF	50
Tag No. :...DRV-8... Qty.: ...1 per Unit ...			Date Sheet No. PES-145-06-DS1-0		
DATA SHEET – A & B					
DATA SHEET – A FOR CONTROL VALVE (WITH PNEUMATIC ACTUATOR) (TO BE FILLED BY PURCHASER)				DATA SHEET – B (TO BE FILLED UP BY BIDDER)	
GENERAL*	PROJECT SERVICE LOCATION DUTY PIPE SIZE (inlet / outlet) PIPE MATERIAL (inlet / outlet)	1X660 MW BHUSAWAL TPS HPH-7 NORMAL DRAIN TO HPH-6 <input checked="" type="checkbox"/> INDOOR <input type="checkbox"/> OUTDOOR <input type="checkbox"/> ON/OFF <input checked="" type="checkbox"/> MODULATING 323.9 x 12.7 323.9 x 12.7 SA 106 GR C SA 106 GR C		
	MODEL NO. TYPE OF BODY: GUIDING : NO. OF PORTS BODY SIZE: PORT SIZE: DESIGN CV END CONNECTION & RATING (ANSI) BODY MATERIAL PACKING: MATERIAL SINGLE / DOUBLE BONNET TYPE TRIM FORM TRIM MATERIAL: SEAT PLUG : CAGE GUIDE BUSH FLOW OUTLET VELOCITY REQUIRED LEAKAGE CLASS NOISE LEVEL (dBA) VACUUM SERVICE ANTI CAVITATION TRIM	BIDDER TO SPECIFY <input checked="" type="checkbox"/> GLOBE <input type="checkbox"/> ANGLE <input type="checkbox"/> TOP <input checked="" type="checkbox"/> CAGE ONE BIDDER TO SPECIFY <input checked="" type="checkbox"/> BWE <input type="checkbox"/> SWE <input type="checkbox"/> FLANGED <input type="checkbox"/> A216 WCB <input checked="" type="checkbox"/> A217 WC9 <input type="checkbox"/> SS <input type="checkbox"/> A217 CS <input type="checkbox"/> A351 CF8M <input type="checkbox"/> PTFE <input checked="" type="checkbox"/> GRAFOIL <input type="checkbox"/> DOUBLE <input checked="" type="checkbox"/> SINGLE <input type="checkbox"/> STD <input type="checkbox"/> EXTENDED <input type="checkbox"/> FINNED <input checked="" type="checkbox"/> LINEAR <input type="checkbox"/> EQ. PERCENTAGE <input type="checkbox"/> QUICK OPEN (ON/OFF) 17-4 PH SS 17-4 PH SS 17-4 PH SS 17-4 PH SS BIDDER TO SPECIFY <input checked="" type="checkbox"/> < 7 M/SEC (WATER) <input type="checkbox"/> MAC NO. < 1/3(STM) <input type="checkbox"/> II <input type="checkbox"/> III <input checked="" type="checkbox"/> IV <input type="checkbox"/> V <input type="checkbox"/> VI LESS THAN 85 dBA <input type="checkbox"/> YES <input checked="" type="checkbox"/> NO <input type="checkbox"/> YES <input checked="" type="checkbox"/> NO		
PNEUMATIC ACTUATOR	MODEL NO. & SIZE CLOSE AT : OPEN AT (KG/CM2g) *TRAVEL TIME FOR OPEN TO CLOSE, CLOSE TO OPEN *VALVE POSN. ON SIGNAL AIR FAILURE *VALVE POSN. ON SUPPLY AIR FAILURE	BIDDER TO SPECIFY TO SUIT ACTUATOR'S DESIGN(AIR TO OPEN) < 10 SEC <input type="checkbox"/> TO OPEN <input type="checkbox"/> STAYPUT <input checked="" type="checkbox"/> TO CLOSE <input checked="" type="checkbox"/> STAYPUT		
ACCESSORIES	POSITIONER (SMART TYPE) AIR FILTER REGULATOR AIR LOCK RELAY POSITION LIMIT SWITCH POSITION TRANSMITTER SOLENOID VALVE E/P CONVERTER JUNCTION BOX HAND WHEEL (SIDE MOUNTED) LOCAL POSITION INDICATOR	<input checked="" type="checkbox"/> REQUIRED <input type="checkbox"/> NOT REQUIRED <input checked="" type="checkbox"/> REQUIRED <input type="checkbox"/> NOT REQUIRED <input checked="" type="checkbox"/> REQUIRED <input type="checkbox"/> NOT REQUIRED <input checked="" type="checkbox"/> REQUIRED <input type="checkbox"/> NOT REQUIRED PART OF POSITIONER <input checked="" type="checkbox"/> REQUIRED <input type="checkbox"/> NOT REQUIRED PART OF POSITIONER <input checked="" type="checkbox"/> REQUIRED <input type="checkbox"/> NOT REQUIRED <input checked="" type="checkbox"/> REQUIRED <input checked="" type="checkbox"/> REQUIRED		

BHEL PEM	DATA SHEET FOR CONTROL VALVES (WITH PNEUMATIC ACTUATOR)						SPECIFICATION NO.: PE-TS-415-145-1801			
							VOLUME			
							SECTION			
							REV. NO.	00	DATE	:10.01.2020
							SHEET	16	OF	50
Tag No. :...DRV-8... Qty.: ...1 per Unit ...						Date Sheet No. PES-145-06-DS1-0				
DATA SHEET – A & B										
DATA SHEET – A FOR CONTROL VALVE (WITH PNEUMATIC ACTUATOR) (TO BE FILLED BY PURCHASER)								DATA SHEET – B (TO BE FILLED UP BY BIDDER)		
PERFORMANCE OF VALVE	LINEARITY HYSTERISIS SENSITIVITY ACCURACY (OVERALL)			± 1% ± 1% ± 0.5% ± 2%					
SERVICE CONDITION*	SL. No. +	LOAD	FLOW (T/HR)	INLET PR. KG/CM2(A)	OUTLET PR. KG/CM2(A)	TEMP DEG (C)	CALC ULATED CV	% VLV LIFT	VLV O/L VELOCITY	
	1.	40% MCR	95.405	21.88	10.3	180.3				
	2.	60% MCR	142.69	31.46	15.1	196.6				
	3.	100% MCR	311.173	52.23	24.6	222.9				
	4.	VWO	349.543	55.63	26.3	226.4				
		VALVE TYPE						<input type="checkbox"/> CAVITATION <input checked="" type="checkbox"/> FLASHING <input type="checkbox"/> HIGH DP		
	* MAX SHUT OFF PRESS (KG/CM2g) 66.2 * BODY DESIGN : PRESS (KG/CM2g) TEMP (DEG C) 66.2 240 * IBR FORM III-C <input type="checkbox"/> REQUIRED <input checked="" type="checkbox"/> NOT REQUIRED								
TOTAL WEIGHT (VALVE + ACTUATOR + ACCESSORIES) Kg									
NOTES: 1. + DESIGN CV SHALL BE BASED ON SERVICE CONDITIONS INDICATED AT SL. NO. <u>4</u> .										

BHEL PEM	DATA SHEET FOR CONTROL VALVES (WITH PNEUMATIC ACTUATOR)		SPECIFICATION NO.: PE-TS-415-145-I801			
			VOLUME			
			SECTION			
			REV. NO.	00	DATE	:10.01.2020
			SHEET	19	OF	50
Tag No. :...DRV-15... Qty.: ...1 per Unit ...		Date Sheet No. PES-145-06-DS1-0				
DATA SHEET – A & B						
DATA SHEET – A FOR CONTROL VALVE (WITH PNEUMATIC ACTUATOR) (TO BE FILLED BY PURCHASER)			DATA SHEET – B (TO BE FILLED UP BY BIDDER)			
GENERAL*	PROJECT SERVICE LOCATION DUTY PIPE SIZE (inlet / outlet) PIPE MATERIAL (inlet / outlet)	1X660 MW BHUSAWAL TPS HPH-6 NORMAL DRAIN TO DEAERATOR <input checked="" type="checkbox"/> INDOOR <input type="checkbox"/> OUTDOOR <input type="checkbox"/> ON/OFF <input checked="" type="checkbox"/> MODULATING 323.9 x 9.53 323.9 x 9.53 SA 106 GR B SA 106 GR B		
BODY*	MODEL NO. TYPE OF BODY: GUIDING : NO. OF PORTS BODY SIZE: PORT SIZE: DESIGN CV END CONNECTION & RATING (ANSI) BODY MATERIAL PACKING: MATERIAL SINGLE / DOUBLE BONNET TYPE TRIM FORM TRIM MATERIAL: SEAT PLUG : CAGE GUIDE BUSH FLOW OUTLET VELOCITY REQUIRED LEAKAGE CLASS NOISE LEVEL (dBA) VACUUM SERVICE ANTI CAVITATION TRIM	BIDDER TO SPECIFY <input checked="" type="checkbox"/> GLOBE <input type="checkbox"/> ANGLE <input type="checkbox"/> TOP <input checked="" type="checkbox"/> CAGE ONE BIDDER TO SPECIFY <input checked="" type="checkbox"/> BWE <input type="checkbox"/> SWE <input type="checkbox"/> FLANGED <input type="checkbox"/> A216 WCB <input checked="" type="checkbox"/> A217 WC6 <input type="checkbox"/> SS <input type="checkbox"/> A217 CS <input type="checkbox"/> A351 CF8M <input type="checkbox"/> PTFE <input checked="" type="checkbox"/> GRAFOIL <input type="checkbox"/> DOUBLE <input checked="" type="checkbox"/> SINGLE <input type="checkbox"/> STD <input type="checkbox"/> EXTENDED <input type="checkbox"/> FINNED <input checked="" type="checkbox"/> LINEAR <input type="checkbox"/> EQ. PERCENTAGE <input type="checkbox"/> QUICK OPEN (ON/OFF) 17-4 PH SS 17-4 PH SS 17-4 PH SS 17-4 PH SS BIDDER TO SPECIFY <input checked="" type="checkbox"/> < 7 M/SEC (WATER) <input type="checkbox"/> MAC NO. < 1/3(STM) <input type="checkbox"/> II <input type="checkbox"/> III <input checked="" type="checkbox"/> IV <input type="checkbox"/> V <input type="checkbox"/> VI LESS THAN 85 dBA <input type="checkbox"/> YES <input checked="" type="checkbox"/> NO <input type="checkbox"/> YES <input checked="" type="checkbox"/> NO		
PNEUMATIC ACTUATOR	MODEL NO. & SIZE CLOSE AT : OPEN AT (KG/CM2g) *TRAVEL TIME FOR OPEN TO CLOSE, CLOSE TO OPEN *VALVE POSN. ON SIGNAL AIR FAILURE *VALVE POSN. ON SUPPLY AIR FAILURE	BIDDER TO SPECIFY TO SUIT ACTUATOR'S DESIGN(AIR TO OPEN) < 10 SEC <input type="checkbox"/> TO OPEN <input type="checkbox"/> STAYPUT <input checked="" type="checkbox"/> TO CLOSE <input checked="" type="checkbox"/> STAYPUT		
ACCESSORI ES	POSITIONER (SMART TYPE) AIR FILTER REGULATOR AIR LOCK RELAY POSITION LIMIT SWITCH POSITION TRANSMITTER SOLENOID VALVE E/P CONVERTER JUNCTION BOX HAND WHEEL (SIDE MOUNTED) LOCAL POSITION INDICATOR	<input checked="" type="checkbox"/> REQUIRED <input type="checkbox"/> NOT REQUIRED <input checked="" type="checkbox"/> REQUIRED <input type="checkbox"/> NOT REQUIRED <input checked="" type="checkbox"/> REQUIRED <input type="checkbox"/> NOT REQUIRED <input checked="" type="checkbox"/> REQUIRED <input type="checkbox"/> NOT REQUIRED PART OF POSITIONER <input checked="" type="checkbox"/> REQUIRED <input type="checkbox"/> NOT REQUIRED PART OF POSITIONER <input checked="" type="checkbox"/> REQUIRED <input type="checkbox"/> NOT REQUIRED <input checked="" type="checkbox"/> REQUIRED <input checked="" type="checkbox"/> REQUIRED		

BHEL PEM	DATA SHEET FOR CONTROL VALVES (WITH PNEUMATIC ACTUATOR)						SPECIFICATION NO.: PE-TS-415-145-1801			
							VOLUME			
							SECTION			
							REV. NO.	00	DATE	:10.01.2020
SHEET		20	OF	50						
Tag No. :...DRV-15... Qty.: ...1 per Unit ...						Date Sheet No. PES-145-06-DS1-0				
DATA SHEET – A & B										
DATA SHEET – A FOR CONTROL VALVE (WITH PNEUMATIC ACTUATOR) (TO BE FILLED BY PURCHASER)								DATA SHEET – B (TO BE FILLED UP BY BIDDER)		
PERFORMANCE OF VALVE	LINEARITY HYSTERISIS SENSITIVITY ACCURACY (OVERALL)			± 1% ± 1% ± 0.5% ± 2%					
SERVICE CONDITION*	SL. No. +	LOAD	FLOW (T/HR)	INLET PR. KG/CM2(A)	OUTLET PR. KG/CM2(A)	TEMP DEG (C)	CALC ULATED CV	% VLV LIFT	VLV O/L VELOCITY	
	1.	40% MCR	122.364	10.14	6.1	162				
	2.	60% MCR	184.367	14.44	8.5	176.3				
	3.	100% MCR	391.118	23.72	12.6	201				
	4.	VWO	437.683	25.18	13.3	203.8				
	VALVE TYPE						<input type="checkbox"/> CAVITATION <input checked="" type="checkbox"/> FLASHING <input type="checkbox"/> HIGH DP			
* MAX SHUT OFF PRESS (KG/CM2g) 30									
* BODY DESIGN : PRESS (KG/CM2g) TEMP (DEG C) 30 210									
* IBR FORM III-C <input type="checkbox"/> REQUIRED <input checked="" type="checkbox"/> NOT REQUIRED									
TOTAL WEIGHT (VALVE + ACTUATOR + ACCESSORIES) Kg									
NOTES:										
1. + DESIGN CV SHALL BE BASED ON SERVICE CONDITIONS INDICATED AT SL. NO. <u>4</u>										

BHEL PEM	DATA SHEET FOR CONTROL VALVES (WITH PNEUMATIC ACTUATOR)						SPECIFICATION NO.: PE-TS-415-145-1801			
							VOLUME			
							SECTION			
							REV. NO.	00	DATE	:10.01.2020
							SHEET	24	OF	50
Tag No. :...DRV-28... Qty.: ...1 per Unit ...										
Date Sheet No. PES-145-06-DS1-0										
DATA SHEET – A & B										
DATA SHEET – A FOR CONTROL VALVE (WITH PNEUMATIC ACTUATOR) (TO BE FILLED BY PURCHASER)								DATA SHEET – B (TO BE FILLED UP BY BIDDER)		
PERFORMANCE OF VALVE	LINEARITY HYSTERISIS SENSITIVITY ACCURACY (OVERALL)			± 1% ± 1% ± 0.5% ± 2%					
SERVICE CONDITION*	SL. No. +	LOAD	FLOW (T/HR)	INLET PR. KG/CM2(A)	OUTLET PR. KG/CM2(A)	TEMP DEG (C)	CALC ULATED CV	% VLV LIFT	VLV O/L VELOCITY	
	1.	40% MCR	52.693	0.929	0.43	79.2				
	2.	60% MCR	74.172	1.27	0.59	86.4				
	3.	100% MCR	138.865	1.99	0.911	98.7				
	4.	VWO	152.189	2.09	0.965	100.1				
	VALVE TYPE						<input type="checkbox"/> CAVITATION <input checked="" type="checkbox"/> FLASHING <input type="checkbox"/> HIGH DP			
	* MAX SHUT OFF PRESS (KG/CM2g) 3.5 * BODY DESIGN : PRESS (KG/CM2g) TEMP (DEG C) 3.5/VACUUM 110 * IBR FORM III-C <input type="checkbox"/> REQUIRED <input checked="" type="checkbox"/> NOT REQUIRED								
TOTAL WEIGHT (VALVE + ACTUATOR + ACCESSORIES) Kg									
NOTES:										
1. + DESIGN CV SHALL BE BASED ON SERVICE CONDITIONS INDICATED AT SL. NO. <u>4</u>										

BHEL PEM	DATA SHEET FOR CONTROL VALVES (WITH PNEUMATIC ACTUATOR)						SPECIFICATION NO.: PE-TS-415-145-1801			
							VOLUME			
							SECTION			
							REV. NO.	00	DATE	:10.01.2020
							SHEET	26	OF	50
Tag No.DRV-31... Qty.: ...1 per Unit ...						Date Sheet No. PES-145-06-DS1-0				
DATA SHEET – A & B										
DATA SHEET – A FOR CONTROL VALVE (WITH PNEUMATIC ACTUATOR) (TO BE FILLED BY PURCHASER)							DATA SHEET – B (TO BE FILLED UP BY BIDDER)			
PERFORMANCE OF VALVE	LINEARITY HYSTERISIS SENSITIVITY ACCURACY (OVERALL)					± 1% ± 1% ± 0.5% ± 2%			
SERVICE CONDITION*	SL. No. +	LOAD	FLOW (T/HR)	INLET PR. KG/CM2(A)	OUTLET PR. KG/CM2(A)	TEMP DEG (C)	CALC ULATED CV	% VLV LIFT	VLV O/L VELOCITY	
	1.	40% MCR	52.693	0.929	0.3	97.04				
	2.	60% MCR	74.172	1.27	0.3	105.88				
	3.	100% MCR	138.865	1.99	0.3	119.45				
	4.	VWO	152.189	2.09	0.3	121.00				
	VALVE TYPE							<input type="checkbox"/> CAVITATION <input checked="" type="checkbox"/> FLASHING <input type="checkbox"/> HIGH DP		
* MAX SHUT OFF PRESS (KG/CM2g) 3.5 * BODY DESIGN : PRESS (KG/CM2g) TEMP (DEG C) 3.5/VACUUM 130 * IBR FORM III-C <input type="checkbox"/> REQUIRED <input checked="" type="checkbox"/> NOT REQUIRED									
TOTAL WEIGHT (VALVE + ACTUATOR + ACCESSORIES) Kg									
NOTES:										
1. + DESIGN CV SHALL BE BASED ON SERVICE CONDITIONS INDICATED AT SL. NO. <u>4</u>										

BHEL PEM	DATA SHEET FOR CONTROL VALVES (WITH PNEUMATIC ACTUATOR)						SPECIFICATION NO.: PE-TS-415-145-1801			
							VOLUME			
							SECTION			
							REV. NO. 00		DATE :10.01.2020	
							SHEET 28		OF 50	
Tag No. :...DRV-34... Qty.: ...1 per Unit ...						Date Sheet No. PES-145-06-DS1-0				
DATA SHEET – A & B										
DATA SHEET – A FOR CONTROL VALVE (WITH PNEUMATIC ACTUATOR) (TO BE FILLED BY PURCHASER)								DATA SHEET – B (TO BE FILLED UP BY BIDDER)		
PERFORMANCE OF VALVE	LINEARITY HYSTERISIS SENSITIVITY ACCURACY (OVERALL)				± 1% ± 1% ± 0.5% ± 2%				
SERVICE CONDITION*	SL. No. +	LOAD	FLOW (T/HR)	INLET PR. KG/CM2(A)	OUTLET PR. KG/CM2(A)	TEMP DEG (C)	CALC ULATED CV	% VLV LIFT	VLV O/L VELOCITY	
	1.	40% MCR	74.057	0.444	0.17	58.4				
	2.	60% MCR	103.782	0.584	0.23	64.1				
	3.	100% MCR	194.962	0.92	0.345	74.0				
	4.	VWO	213.349	0.966	0.365	75.2				
	5.	ALL HPH OUT	219.774	1.018	0.378	76.4				
	VALVE TYPE							<input type="checkbox"/> CAVITATION <input checked="" type="checkbox"/> FLASHING <input type="checkbox"/> HIGH DP		
	* MAX SHUT OFF PRESS (KG/CM2g) 3.5 * BODY DESIGN : PRESS (KG/CM2g) TEMP (DEG C) 3.5/VACUUM 85 * IBR FORM III-C <input type="checkbox"/> REQUIRED <input checked="" type="checkbox"/> NOT REQUIRED								
TOTAL WEIGHT (VALVE + ACTUATOR + ACCESSORIES) Kg									
NOTES:										
1. + DESIGN CV SHALL BE BASED ON SERVICE CONDITIONS INDICATED AT SL. NO. <u>4</u>										

BHEL PEM		DATA SHEET FOR CONTROL VALVES (WITH PNEUMATIC ACTUATOR)		SPECIFICATION NO.: PE-TS-415-145-1801	
				VOLUME	
		SECTION			
		REV. NO.	00	DATE	:10.01.2020
		SHEET	29	OF	50
Tag No. :...DRV-37... Qty.: ...1 per Unit ...			Date Sheet No. PES-145-06-DS1-0		
PID NO: PE-DG-415-100-N104					
DATA SHEET – A & B					
DATA SHEET – A FOR CONTROL VALVE (WITH PNEUMATIC ACTUATOR) (TO BE FILLED BY PURCHASER)				DATA SHEET – B (TO BE FILLED UP BY BIDDER)	
GENERAL*	PROJECT	1X660 MW BHUSAWAL TPS		
	SERVICE	LPH-2 ALT. DRAIN TO FLASH TANK-B		
LOCATION	DUTY	<input checked="" type="checkbox"/> INDOOR	<input type="checkbox"/> OUTDOOR	
	PIPE SIZE (inlet / outlet)	<input type="checkbox"/> ON/OFF	<input checked="" type="checkbox"/> MODULATING	
PIPE MATERIAL (inlet / outlet)	PIPE SIZE (inlet / outlet)	273 x 6.35	323.9 x 9.53	
	PIPE MATERIAL (inlet / outlet)	SA 106 GR B	SA 106 GR B	
BODY*	MODEL NO.	BIDDER TO SPECIFY		
	TYPE OF BODY: GUIDING : NO. OF PORTS	<input checked="" type="checkbox"/> GLOBE <input type="checkbox"/> ANGLE <input type="checkbox"/> TOP <input checked="" type="checkbox"/> CAGE ONE		
BODY MATERIAL	BODY SIZE: PORT SIZE: DESIGN CV	BIDDER TO SPECIFY		
	END CONNECTION & RATING (ANSI)	<input checked="" type="checkbox"/> BWE <input type="checkbox"/> SWE <input type="checkbox"/> FLANGED		
PACKING: MATERIAL SINGLE / DOUBLE	BODY MATERIAL	<input type="checkbox"/> A216 WCB <input checked="" type="checkbox"/> A217 WC6 <input type="checkbox"/> SS <input type="checkbox"/> A217 CS		
	BONNET TYPE	<input type="checkbox"/> A351 CF8M		
TRIM FORM	PACKING: MATERIAL SINGLE / DOUBLE	<input type="checkbox"/> PTFE <input checked="" type="checkbox"/> GRAFOIL <input checked="" type="checkbox"/> DOUBLE <input type="checkbox"/> SINGLE		
	TRIM MATERIAL: SEAT PLUG	<input type="checkbox"/> STD <input type="checkbox"/> EXTENDED <input type="checkbox"/> FINNED		
: CAGE GUIDE BUSH	TRIM MATERIAL: SEAT PLUG	<input checked="" type="checkbox"/> LINEAR <input type="checkbox"/> EQ. PERCENTAGE		
	: CAGE GUIDE BUSH	<input type="checkbox"/> QUICK OPEN (ON/OFF)		
FLOW	TRIM MATERIAL: SEAT PLUG	17-4 PH SS 17-4 PH SS		
	OUTLET VELOCITY	17-4 PH SS 17-4 PH SS		
REQUIRED LEAKAGE CLASS	FLOW	BIDDER TO SPECIFY		
	NOISE LEVEL (dBA)	<input checked="" type="checkbox"/> < 7 M/SEC (WATER) <input type="checkbox"/> MAC NO. < 1/3(STM)		
VACUUM SERVICE	REQUIRED LEAKAGE CLASS	<input type="checkbox"/> II <input type="checkbox"/> III <input type="checkbox"/> IV <input checked="" type="checkbox"/> V <input type="checkbox"/> VI		
	ANTI CAVITATION TRIM	LESS THAN 85 dBA		
PNEUMATIC ACTUATOR	MODEL NO. & SIZE	<input checked="" type="checkbox"/> YES <input type="checkbox"/> NO		
	CLOSE AT : OPEN AT (KG/CM2g)	<input type="checkbox"/> YES <input checked="" type="checkbox"/> NO		
*TRAVEL TIME FOR	OPEN TO CLOSE, CLOSE TO OPEN	BIDDER TO SPECIFY		
	*VALVE POSN. ON SIGNAL AIR FAILURE	TO SUIT ACTUATOR'S DESIGN(AIR TO CLOSE)		
*VALVE POSN. ON SUPPLY AIR FAILURE	*VALVE POSN. ON SIGNAL AIR FAILURE	< 10 SEC		
	*VALVE POSN. ON SUPPLY AIR FAILURE	<input checked="" type="checkbox"/> TO OPEN <input type="checkbox"/> STAYPUT <input type="checkbox"/> TO CLOSE		
ACCESSORIES	POSITIONER (SMART TYPE)	<input checked="" type="checkbox"/> STAYPUT		
	AIR FILTER REGULATOR	<input checked="" type="checkbox"/> REQUIRED <input type="checkbox"/> NOT REQUIRED		
SOLENOID VALVE	AIR LOCK RELAY	<input checked="" type="checkbox"/> REQUIRED <input type="checkbox"/> NOT REQUIRED		
	E/P CONVERTER	<input checked="" type="checkbox"/> REQUIRED <input type="checkbox"/> NOT REQUIRED		
JUNCTION BOX	POSITION LIMIT SWITCH	<input checked="" type="checkbox"/> REQUIRED <input type="checkbox"/> NOT REQUIRED		
	POSITION TRANSMITTER	<input checked="" type="checkbox"/> REQUIRED <input type="checkbox"/> NOT REQUIRED		
HAND WHEEL (SIDE MOUNTED)	SOLENOID VALVE	PART OF POSITIONER		
	E/P CONVERTER	<input checked="" type="checkbox"/> REQUIRED <input type="checkbox"/> NOT REQUIRED		
LOCAL POSITION INDICATOR	JUNCTION BOX	PART OF POSITIONER		
	HAND WHEEL (SIDE MOUNTED)	<input checked="" type="checkbox"/> REQUIRED <input type="checkbox"/> NOT REQUIRED		
LOCAL POSITION INDICATOR	LOCAL POSITION INDICATOR	<input checked="" type="checkbox"/> REQUIRED		
		<input checked="" type="checkbox"/> REQUIRED		

BHEL PEM	DATA SHEET FOR CONTROL VALVES (WITH PNEUMATIC ACTUATOR)						SPECIFICATION NO.: PE-TS-415-145-1801			
							VOLUME			
							SECTION			
							REV. NO.	00	DATE	:10.01.2020
SHEET		34	OF		50					
Tag No. :...DRV-2... Qty.: ...1 per Unit ...						Date Sheet No. PES-145-06-DS1-0				
DATA SHEET – A & B										
DATA SHEET – A FOR CONTROL VALVE (WITH PNEUMATIC ACTUATOR) (TO BE FILLED BY PURCHASER)							DATA SHEET – B (TO BE FILLED UP BY BIDDER)			
PERFORMANCE OF VALVE	LINEARITY HYSTERISIS SENSITIVITY ACCURACY (OVERALL)			± 1% ± 1% ± 0.5% ± 2%					
SERVICE CONDITION*	SL. No. +	LOAD	FLOW (T/HR)	INLET PR. KG/CM2(A)	OUTLET PR. KG/CM2(A)	TEMP DEG (C)	CALC ULATED CV	% VLV LIFT	VLV O/L VELOCITY	
	1.	40% MCR	37.625	32.86	22.5	219.0				
	2.	60% MCR	54.751	46.58	33.1	239.6				
	3.	100% MCR	125.028	76.89	54.6	270.2				
	4.	VWO	143.285	82.82	58.3	274.9				
	VALVE TYPE						<input type="checkbox"/> CAVITATION <input checked="" type="checkbox"/> FLASHING <input type="checkbox"/> HIGH DP			
* MAX SHUT OFF PRESS (KG/CM2g) 88									
* BODY DESIGN : PRESS (KG/CM2g) TEMP (DEG C) 88 285									
* IBR FORM III-C <input type="checkbox"/> REQUIRED <input checked="" type="checkbox"/> NOT REQUIRED									
TOTAL WEIGHT (VALVE + ACTUATOR + ACCESSORIES) Kg									
NOTES:										
1. + DESIGN CV SHALL BE BASED ON SERVICE CONDITIONS INDICATED AT SL. NO. <u>4</u>										

BHEL PEM	DATA SHEET FOR CONTROL VALVES (WITH PNEUMATIC ACTUATOR)		SPECIFICATION NO.: PE-TS-415-145-1801			
			VOLUME			
			SECTION			
			REV. NO.	00	DATE	:10.01.2020
			SHEET	35	OF	50
Tag No. :...DRV-5... Qty.: ...1 per Unit ...		Date Sheet No. PES-145-06-DS1-0				
DATA SHEET – A & B						
DATA SHEET – A FOR CONTROL VALVE (WITH PNEUMATIC ACTUATOR) (TO BE FILLED BY PURCHASER)			DATA SHEET – B (TO BE FILLED UP BY BIDDER)			
GENERAL*	PROJECT SERVICE	1X660 MW BHUSAWAL TPS			
	LOCATION	HPH-8 ALT. DRAIN TO FLASH TANK-A			
BODY*	DUTY	<input checked="" type="checkbox"/> INDOOR <input type="checkbox"/> OUTDOOR			
	PIPE SIZE (inlet / outlet)	<input type="checkbox"/> ON/OFF <input checked="" type="checkbox"/> MODULATING			
	PIPE MATERIAL (inlet / outlet)	219.1 x 10.31 273 x 12.7			
		SA 106 GR C SA 106 GR C			
					
PNEUMATIC ACTUATOR	MODEL NO.	BIDDER TO SPECIFY			
	TYPE OF BODY: GUIDING : NO. OF PORTS	<input checked="" type="checkbox"/> GLOBE <input type="checkbox"/> ANGLE <input type="checkbox"/> TOP <input checked="" type="checkbox"/> CAGE ONE			
	BODY SIZE: PORT SIZE: DESIGN CV	BIDDER TO SPECIFY			
	END CONNECTION & RATING (ANSI)	<input checked="" type="checkbox"/> BWE <input type="checkbox"/> SWE <input type="checkbox"/> FLANGED			
	BODY MATERIAL	<input type="checkbox"/> A216 WCB <input checked="" type="checkbox"/> A217 WC9 <input type="checkbox"/> SS <input type="checkbox"/> A217 CS			
		<input type="checkbox"/> A351 CF8M			
	PACKING: MATERIAL SINGLE / DOUBLE	<input type="checkbox"/> PTFE <input checked="" type="checkbox"/> GRAFOIL <input checked="" type="checkbox"/> DOUBLE <input type="checkbox"/> SINGLE			
	BONNET TYPE	<input type="checkbox"/> STD <input type="checkbox"/> EXTENDED <input type="checkbox"/> FINNED			
	TRIM FORM	<input checked="" type="checkbox"/> LINEAR <input type="checkbox"/> EQ. PERCENTAGE			
		<input type="checkbox"/> QUICK OPEN (ON/OFF)			
ACCESSORIES	TRIM MATERIAL: SEAT PLUG	440 C 440 C			
	: CAGE GUIDE BUSH	440 C 440 C			
	FLOW	BIDDER TO SPECIFY			
	OUTLET VELOCITY	<input checked="" type="checkbox"/> < 7 M/SEC (WATER) <input type="checkbox"/> MAC NO. < 1/3(STM)			
	REQUIRED LEAKAGE CLASS	<input type="checkbox"/> II <input type="checkbox"/> III <input type="checkbox"/> IV <input checked="" type="checkbox"/> V <input type="checkbox"/> VI			
	NOISE LEVEL (dBA)	LESS THAN 85 dBA			
	VACUUM SERVICE	<input checked="" type="checkbox"/> YES <input type="checkbox"/> NO			
	ANTI CAVITATION TRIM	<input type="checkbox"/> YES <input checked="" type="checkbox"/> NO			
					
					
ACCESSORIES	MODEL NO. & SIZE	BIDDER TO SPECIFY			
	CLOSE AT : OPEN AT (KG/CM2g)	TO SUIT ACTUATOR'S DESIGN(AIR TO CLOSE)			
	*TRAVEL TIME FOR	< 10 SEC			
	OPEN TO CLOSE, CLOSE TO OPEN	<input checked="" type="checkbox"/> TO OPEN <input type="checkbox"/> STAYPUT <input type="checkbox"/> TO CLOSE			
	*VALVE POSN. ON SIGNAL AIR FAILURE	<input checked="" type="checkbox"/> STAYPUT			
	*VALVE POSN. ON SUPPLY AIR FAILURE				
	POSITIONER (SMART TYPE)	<input checked="" type="checkbox"/> REQUIRED <input type="checkbox"/> NOT REQUIRED			
	AIR FILTER REGULATOR	<input checked="" type="checkbox"/> REQUIRED <input type="checkbox"/> NOT REQUIRED			
	AIR LOCK RELAY	<input checked="" type="checkbox"/> REQUIRED <input type="checkbox"/> NOT REQUIRED			
	POSITION LIMIT SWITCH	<input checked="" type="checkbox"/> REQUIRED <input type="checkbox"/> NOT REQUIRED			
POSITION TRANSMITTER	PART OF POSITIONER				
SOLENOID VALVE	<input checked="" type="checkbox"/> REQUIRED <input type="checkbox"/> NOT REQUIRED				
E/P CONVERTER	PART OF POSITIONER				
JUNCTION BOX	<input checked="" type="checkbox"/> REQUIRED <input type="checkbox"/> NOT REQUIRED				
HAND WHEEL (SIDE MOUNTED)	<input checked="" type="checkbox"/> REQUIRED				
LOCAL POSITION INDICATOR	<input checked="" type="checkbox"/> REQUIRED				

BHEL PEM	DATA SHEET FOR CONTROL VALVES (WITH PNEUMATIC ACTUATOR)	SPECIFICATION NO.: PE-TS-415-145-1801	
		VOLUME	
		SECTION	
		REV. NO. 00	DATE :10.01.2020
		SHEET 36	OF 50

Tag No. :...DRV-5... Qty.: ...1 per Unit ...

Date Sheet No. PES-145-06-DS1-0

DATA SHEET – A & B

DATA SHEET – A FOR CONTROL VALVE (WITH PNEUMATIC ACTUATOR)
(TO BE FILLED BY PURCHASER)

DATA SHEET – B
(TO BE FILLED UP BY
BIDDER)

PERFORMANCE OF VALVE	LINEARITY HYSTERESIS SENSITIVITY ACCURACY (OVERALL)	± 1% ± 1% ± 0.5% ± 2%
----------------------	--	--------------------------------	----------------------------------

SERVICE CONDITION*	SL. No. +	LOAD	FLOW (T/HR)	INLET PR. KG/CM2(A)	OUTLET PR. KG/CM2(A)	TEMP DEG (C)	CALC ULATED CV	% VLV LIFT	VLV O/L VELOCITY
	1.	40% MCR	37.625	32.86	0.3	237.84			
	2.	60% MCR	54.751	46.58	0.3	258.32			
	3.	100% MCR	125.028	76.89	0.3	290.86			
	4.	VWO	143.285	82.82	0.5	296.02			
	VALVE TYPE							<input type="checkbox"/> CAVITATION	<input checked="" type="checkbox"/> FLASHING
							<input type="checkbox"/> HIGH DP		
* MAX SHUT OFF PRESS (KG/CM2g) 88								
* BODY DESIGN : PRESS (KG/CM2g) TEMP (DEG C) 88/VACUUM 300								
* IBR FORM III-C <input type="checkbox"/> REQUIRED <input checked="" type="checkbox"/> NOT REQUIRED								
TOTAL WEIGHT (VALVE + ACTUATOR + ACCESSORIES) Kg								

NOTES:

1. + DESIGN CV SHALL BE BASED ON SERVICE CONDITIONS INDICATED AT SL. NO. 4

BHEL PEM	DATA SHEET FOR CONTROL VALVES (WITH PNEUMATIC ACTUATOR)						SPECIFICATION NO.: PE-TS-415-145-1801			
							VOLUME			
							SECTION			
							REV. NO.	00	DATE	:10.01.2020
							SHEET	38	OF	50
Tag No. :...DRV-65... Qty.: ...1 per Unit ...										
Date Sheet No. PES-145-06-DS1-0										
DATA SHEET – A & B										
DATA SHEET – A FOR CONTROL VALVE (WITH PNEUMATIC ACTUATOR) (TO BE FILLED BY PURCHASER)								DATA SHEET – B (TO BE FILLED UP BY BIDDER)		
PERFORMANCE OF VALVE	LINEARITY HYSTERISIS SENSITIVITY ACCURACY (OVERALL)			± 1% ± 1% ± 0.5% ± 2%					
SERVICE CONDITION*	SL. No. +	LOAD	FLOW (T/HR)	INLET PR. KG/CM2(A)	OUTLET PR. KG/CM2(A)	TEMP DEG (C)	CALC ULATED CV	% VLV LIFT	VLV O/L VELOCITY	
	1.	40% MCR	32.567	2.54	0.89	98.1				
	2.	60% MCR	45.329	3.51	1.27	107.2				
	3.	100% MCR	85.61	5.52	1.97	121.4				
	4.	VWO	93.858	5.81	2.09	123.1				
	5.									
	VALVE TYPE						<input type="checkbox"/> CAVITATION <input checked="" type="checkbox"/> FLASHING <input type="checkbox"/> HIGH DP			
	* MAX SHUT OFF PRESS (KG/CM2g) 7 * BODY DESIGN : PRESS (KG/CM2g) TEMP (DEG C) 7/VACUUM 135 * IBR FORM III-C <input type="checkbox"/> REQUIRED <input checked="" type="checkbox"/> NOT REQUIRED								
TOTAL WEIGHT (VALVE + ACTUATOR + ACCESSORIES) Kg									
NOTES:										
1. + DESIGN CV SHALL BE BASED ON SERVICE CONDITIONS INDICATED AT SL. NO. <u>4</u>										

BHEL PEM	DATA SHEET FOR CONTROL VALVES (WITH PNEUMATIC ACTUATOR)						SPECIFICATION NO.: PE-TS-415-145-1801			
							VOLUME			
							SECTION			
							REV. NO. 00		DATE :10.01.2020	
							SHEET 40		OF 50	
Tag No. :...DRV-68... Qty.: ...1 per Unit ...						Date Sheet No. PES-145-06-DS1-0				
DATA SHEET – A & B										
DATA SHEET – A FOR CONTROL VALVE (WITH PNEUMATIC ACTUATOR) (TO BE FILLED BY PURCHASER)							DATA SHEET – B (TO BE FILLED UP BY BIDDER)			
PERFORMANCE OF VALVE	LINEARITY			± 1%					
	HYSTERESIS			± 1%					
	SENSITIVITY			± 0.5%					
	ACCURACY (OVERALL)			± 2%					
SERVICE CONDITION*	SL. No. +	LOAD	FLOW (T/HR)	INLET PR. KG/CM2(A)	OUTLET PR. KG/CM2(A)	TEMP DEG (C)	CALC ULATED CV	% VLV LIFT	VLV O/L VELOCITY	
	1.	40% MCR	34.4	2.54	0.89	127.31				
	2.	60% MCR	46.8	3.56	0.3	138.28				
	3.	100% MCR	88.9	5.52	0.3	154.85				
	4.	VWO	96.7	5.87	0.3	156.82				
	VALVE TYPE						<input type="checkbox"/> CAVITATION <input checked="" type="checkbox"/> FLASHING <input type="checkbox"/> HIGH DP			
	* MAX SHUT OFF PRESS (KG/CM2g) 7								
* BODY DESIGN : PRESS (KG/CM2g) TEMP (DEG C) 7/VACUUM 165									
* IBR FORM III-C <input type="checkbox"/> REQUIRED <input checked="" type="checkbox"/> NOT REQUIRED									
TOTAL WEIGHT (VALVE + ACTUATOR + ACCESSORIES) Kg									
NOTES:										
1. + DESIGN CV SHALL BE BASED ON SERVICE CONDITIONS INDICATED AT SL. NO. <u>4</u>										

BHEL PEM		DATA SHEET FOR CONTROL VALVES (WITH PNEUMATIC ACTUATOR)		SPECIFICATION NO.: PE-TS-415-145-1801			
				VOLUME			
				SECTION			
				REV. NO.	00	DATE	:10.01.2020
				SHEET	41	OF	50
Tag No. :...DM-50... Qty.: ...1 per Unit ...		Date Sheet No. PES-145-06-DS1-0					
PID NO: PE-DG-415-100-N106		DATA SHEET – A & B					
DATA SHEET – A FOR CONTROL VALVE (WITH PNEUMATIC ACTUATOR) (TO BE FILLED BY PURCHASER)				DATA SHEET – B (TO BE FILLED UP BY BIDDER)			
GENERAL*	PROJECT SERVICE	1X660 MW BHUSAWAL TPS				
	LOCATION	DM MU TO HOTWELL HIGH CAPACITY				
BODY*	DUTY	<input checked="" type="checkbox"/> INDOOR <input type="checkbox"/> OUTDOOR <input type="checkbox"/> ON/OFF <input checked="" type="checkbox"/> MODULATING				
	PIPE SIZE (inlet / outlet)	168.3 x 3.4 168.3 x 3.4				
	PIPE MATERIAL (inlet / outlet)	SA 312 TP 304 (ERW) SA 312 TP 304 (ERW)				
	MODEL NO.	BIDDER TO SPECIFY				
	TYPE OF BODY: GUIDING : NO. OF PORTS	<input checked="" type="checkbox"/> GLOBE <input type="checkbox"/> ANGLE <input type="checkbox"/> TOP <input checked="" type="checkbox"/> CAGE ONE				
	BODY SIZE: PORT SIZE: DESIGN CV	BIDDER TO SPECIFY				
	END CONNECTION & RATING (ANSI)	<input checked="" type="checkbox"/> BWE <input type="checkbox"/> SWE <input type="checkbox"/> FLANGED <input type="checkbox"/> A216 WCB <input type="checkbox"/> A217 WC6 <input type="checkbox"/> SS <input type="checkbox"/> A217 CS				
	BODY MATERIAL	<input checked="" type="checkbox"/> A351 CF8M <input type="checkbox"/> PTFE <input checked="" type="checkbox"/> GRAFOIL <input checked="" type="checkbox"/> DOUBLE <input type="checkbox"/> SINGLE				
	PACKING: MATERIAL SINGLE / DOUBLE	<input type="checkbox"/> STD <input type="checkbox"/> EXTENDED <input type="checkbox"/> FINNED <input type="checkbox"/> LINEAR <input checked="" type="checkbox"/> EQ. PERCENTAGE				
	BONNET TYPE	<input type="checkbox"/> QUICK OPEN (ON/OFF) SS 316 STELLITED SS 316 STELLITED				
	TRIM FORM	SS 316 STELLITED SS 316 STELLITED				
	TRIM MATERIAL: SEAT PLUG	BIDDER TO SPECIFY				
	: CAGE GUIDE BUSH	<input checked="" type="checkbox"/> < 7 M/SEC (WATER) <input type="checkbox"/> MAC NO. < 1/3(STM) <input type="checkbox"/> II <input type="checkbox"/> III <input checked="" type="checkbox"/> IV <input type="checkbox"/> V <input type="checkbox"/> VI LESS THAN 85 dBA				
	FLOW	<input checked="" type="checkbox"/> YES <input type="checkbox"/> NO <input type="checkbox"/> YES <input checked="" type="checkbox"/> NO				
	OUTLET VELOCITY					
	REQUIRED LEAKAGE CLASS					
	NOISE LEVEL (dBA)					
	VACUUM SERVICE					
	ANTI CAVITATION TRIM					
PNEUMATIC ACTUATOR	MODEL NO. & SIZE	BIDDER TO SPECIFY				
	CLOSE AT : OPEN AT (KG/CM2g)	TO SUIT ACTUATOR'S DESIGN(AIR TO CLOSE)				
	*TRAVEL TIME FOR	< 10 SEC				
	OPEN TO CLOSE, CLOSE TO OPEN	<input checked="" type="checkbox"/> TO OPEN <input type="checkbox"/> STAYPUT <input type="checkbox"/> TO CLOSE <input checked="" type="checkbox"/> STAYPUT				
	*VALVE POSN. ON SIGNAL AIR FAILURE					
	*VALVE POSN. ON SUPPLY AIR FAILURE					
ACCESSORIES	POSITIONER (SMART TYPE)	<input checked="" type="checkbox"/> REQUIRED <input type="checkbox"/> NOT REQUIRED				
	AIR FILTER REGULATOR	<input checked="" type="checkbox"/> REQUIRED <input type="checkbox"/> NOT REQUIRED				
	AIR LOCK RELAY	<input checked="" type="checkbox"/> REQUIRED <input type="checkbox"/> NOT REQUIRED				
	POSITION LIMIT SWITCH	<input checked="" type="checkbox"/> REQUIRED <input type="checkbox"/> NOT REQUIRED				
	POSITION TRANSMITTER	PART OF POSITIONER				
	SOLENOID VALVE	<input checked="" type="checkbox"/> REQUIRED <input type="checkbox"/> NOT REQUIRED				
	E/P CONVERTER	PART OF POSITIONER				
	JUNCTION BOX	<input checked="" type="checkbox"/> REQUIRED <input type="checkbox"/> NOT REQUIRED				
HAND WHEEL (SIDE MOUNTED)	<input checked="" type="checkbox"/> REQUIRED					
LOCAL POSITION INDICATOR	<input checked="" type="checkbox"/> REQUIRED					

BHEL PEM	DATA SHEET FOR CONTROL VALVES (WITH PNEUMATIC ACTUATOR)						SPECIFICATION NO.: PE-TS-415-145-1801			
							VOLUME			
							SECTION			
							REV. NO.	00	DATE	:10.01.2020
							SHEET	48	OF	50
Tag No.: ASV-2 Qty.: 1 per Unit Date Sheet No. PES-145-06-DS1-0										
DATA SHEET – A & B										
DATA SHEET – A FOR CONTROL VALVE (WITH PNEUMATIC ACTUATOR) (TO BE FILLED BY PURCHASER)								DATA SHEET – B (TO BE FILLED UP BY BIDDER)		
PERFORMANCE OF VALVE	LINEARITY HYSTERISIS SENSITIVITY ACCURACY (OVERALL)			± 1% ± 1% ± 0.5% ± 2%					
SERVICE CONDITION*	SL. No. +	LOAD	FLOW (T/HR)	INLET PR. KG/CM2(A)	OUTLET PR. KG/CM2(A)	TEMP DEG (C)	CALC ULATED CV	% VLV LIFT	VLV O/L VELOCITY	
	1.	BFPT ROLLING/WARMUP	2.0	16	8.0	290				
	2.	15% TMCR	15.0	16	8.0	290				
	3.	30% TMCR	25.0	16	8.0	290				
	VALVE TYPE						<input type="checkbox"/> CAVITATION <input type="checkbox"/> FLASHING <input checked="" type="checkbox"/> HIGH DP			
	* MAX SHUT OFF PRESS (KG/CM2g) 20								
	* BODY DESIGN : PRESS (KG/CM2g) TEMP (DEG C) 20 350								
TOTAL WEIGHT (VALVE + ACTUATOR + ACCESSORIES) Kg									
NOTES:										
1. + DESIGN CV SHALL BE BASED ON SERVICE CONDITION INDICATED AT SL. NO. 3 AND SHALL BE CHECKED FOR ALL SPECIFIED CONDITIONS AS PER SPECIFICATION CLAUSE NUMBER 3.1.7.										

BHEL PEM	DATA SHEET FOR CONTROL VALVES (WITH PNEUMATIC ACTUATOR)		SPECIFICATION NO.: PE-TS-415-145-1801	
			VOLUME	
			SECTION	
			REV. NO. 00	DATE :10.01.2020
			SHEET 49	OF 50
Tag No. : CRHV-2		Qty.:1 per Unit	Date Sheet No. PES-145-06-DS1-0	
DATA SHEET – A & B				
DATA SHEET – A FOR CONTROL VALVE (WITH PNEUMATIC ACTUATOR) (TO BE FILLED BY PURCHASER)			DATA SHEET – B (TO BE FILLED UP BY BIDDER)	
GENERAL*	PROJECT	1X660 MW BHUSAWAL TPS	
	SERVICE	CRH TO BFPT	
BODY*	LOCATION	<input checked="" type="checkbox"/> INDOOR <input type="checkbox"/> OUTDOOR	
	DUTY	<input type="checkbox"/> ON/OFF <input checked="" type="checkbox"/> MODULATING	
	PIPE SIZE (inlet / outlet)	273 x 12.7 323.9 x 12.7	
	PIPE MATERIAL (inlet / outlet)	SA 106 GR C SA 106 GR C	
	MODEL NO.	BIDDER TO SPECIFY	
	TYPE OF BODY: GUIDING : NO. OF PORTS	<input checked="" type="checkbox"/> GLOBE <input type="checkbox"/> ANGLE <input type="checkbox"/> TOP <input checked="" type="checkbox"/> CAGE ONE	
	BODY SIZE: PORT SIZE: DESIGN CV	BIDDER TO SPECIFY	
	END CONNECTION & RATING (ANSI)	<input checked="" type="checkbox"/> BWE <input type="checkbox"/> SWE <input type="checkbox"/> FLANGED	
	BODY MATERIAL	<input checked="" type="checkbox"/> A216 WCB <input type="checkbox"/> A217 WC9 <input type="checkbox"/> SS	
		<input type="checkbox"/> A217 CS	
		<input type="checkbox"/> A351 CF8M	
	PACKING: MATERIAL SINGLE / DOUBLE BONNET TYPE	<input type="checkbox"/> PTFE <input checked="" type="checkbox"/> GRAFOIL <input type="checkbox"/> DOUBLE <input checked="" type="checkbox"/> SINGLE	
	TRIM FORM	<input type="checkbox"/> STD <input type="checkbox"/> EXTENDED <input type="checkbox"/> FINNED	
		<input checked="" type="checkbox"/> LINEAR <input type="checkbox"/> EQ. PERCENTAGE	
		<input type="checkbox"/> QUICK OPEN (ON/OFF)	
	TRIM MATERIAL: SEAT PLUG	SS 316 STELLITED SS 316 STELLITED	
	: CAGE GUIDE BUSH	SS 316 STELLITED SS 316 STELLITED	
	FLOW	BIDDER TO SPECIFY	
	OUTLET VELOCITY	<input type="checkbox"/> < 7 M/SEC (WATER) <input checked="" type="checkbox"/> MAC NO. < 1/3(STM)	
	REQUIRED LEAKAGE CLASS	<input type="checkbox"/> II <input type="checkbox"/> III <input type="checkbox"/> IV <input checked="" type="checkbox"/> V <input type="checkbox"/> VI	
	NOISE LEVEL (dBA) (spec. 3.1.14)	LESS THAN 85 dBA	
	VACUUM SERVICE	<input type="checkbox"/> YES <input checked="" type="checkbox"/> NO	
	ANTI CAVITATION TRIM	<input type="checkbox"/> YES <input checked="" type="checkbox"/> NO	
PNEUMATIC ACTUATOR	MODEL NO. & SIZE	BIDDER TO SPECIFY	
	CLOSE AT : OPEN AT (KG/CM2g)	TO SUIT ACTUATOR DESIGN(AIR TO CLOSE)	
	*TRAVEL TIME FOR OPEN TO CLOSE, CLOSE TO OPEN	< 10 SEC	
	*VALVE POSN. ON SIGNAL AIR FAILURE	<input type="checkbox"/> TO OPEN <input type="checkbox"/> STAYPUT <input checked="" type="checkbox"/> TO CLOSE	
	*VALVE POSN. ON SUPPLY AIR FAILURE	<input checked="" type="checkbox"/> STAYPUT	
ACCESSORIES	POSITIONER (SMART TYPE)	<input checked="" type="checkbox"/> REQUIRED <input type="checkbox"/> NOT REQUIRED	
	AIR FILTER REGULATOR	<input checked="" type="checkbox"/> REQUIRED <input type="checkbox"/> NOT REQUIRED	
	AIR LOCK RELAY	<input checked="" type="checkbox"/> REQUIRED <input type="checkbox"/> NOT REQUIRED	
	POSITION LIMIT SWITCH	<input checked="" type="checkbox"/> REQUIRED <input type="checkbox"/> NOT REQUIRED	
	POSITION TRANSMITTER	PART OF POSITIONER	
	SOLENOID VALVE	<input checked="" type="checkbox"/> REQUIRED <input type="checkbox"/> NOT REQUIRED	
	E/P CONVERTER	PART OF POSITIONER	
	JUNCTION BOX	<input checked="" type="checkbox"/> REQUIRED <input type="checkbox"/> NOT REQUIRED	
	HAND WHEEL (SIDE MOUNTED)	<input checked="" type="checkbox"/> REQUIRED	
LOCAL POSITION INDICATOR	<input checked="" type="checkbox"/> REQUIRED		

	DATA SHEET FOR CONTROL VALVES (WITH PNEUMATIC ACTUATOR)		SPECIFICATION NO. PE-TS-415-145-1104	
			VOLUME	
			SECTION	
			REV. NO. 02	DATE: 08.03.19
1X660 MW BHUSAWAL STPP		SHEET 51 OF 51		
Tag No.....		Quantity.....		Data Sheet No. PES-145-06-DS1-0
ITEMS SHALL BE APPLICABLE FOR TAG Nos. WHEREVER STATEMENT "REQUIRED" INDICATED IN THE INDIVIDUAL CV DATA SHEETS				
DATA SHEET – A & B for ACCESSORIES				
DATA SHEET – A FOR CONTROL VALVE (WITH PNEUMATIC ACTUATOR) (TO BE FILLED BY PURCHASER)			DATA SHEET – B (TO BE FILLED-UP BY BIDDER)	
POSITIONER (SMART)	MFR. & MODEL NUMBER		TO BE INDICATED IN VENDOR'S DOCUMENT	
	BYPASS	GAUGES	ENCL. CLASS	<input type="checkbox"/> YES <input checked="" type="checkbox"/> NO <input type="checkbox"/> THREE <input checked="" type="checkbox"/> TWO <input checked="" type="checkbox"/> IP-65
	INPUT SIGNAL (ELECTRICAL)		4-20 mA DC	
	OUTPUT SIGNAL (PNEUMATIC)(Kg / Cm ²)		TO SUIT ACTUATOR	
AIR FILTER REGULATOR	MFR. & MODEL NUMBER		TO BE INDICATED IN VENDOR'S DOCUMENT	
	AIR SUPPLY PRESS (Kg / Cm ² g)		<input checked="" type="checkbox"/> 5.0 - 8.0	
	FILTER SIZE		5 MICRONS	
	OUTPUT PRESS (Kg / Cm ² g)		TO SUIT SMART POSITIONER	
	OUTPUT GAUGE		<input checked="" type="checkbox"/> REQUIRED <input type="checkbox"/> NOT REQUIRED	
AIR LOCK	MFR. & MODEL NUMBER		TO BE INDICATED IN VENDOR'S DOCUMENT	
	SET PRESS (Kg / Cm ²)		TO BE INDICATED IN VENDOR'S DOCUMENT	
	SUPPLY PRESS (Kg / Cm ²)		<input checked="" type="checkbox"/> 5.0 - 8.0	
	RESET TYPE		AUTO	
	VENT PLUG		REQUIRED	
LIMIT SWITCH (APPLICABLE FOR ON/OFF VALVE ONLY)	MFR. & MODEL NUMBER		TO BE INDICATED IN VENDOR'S DOCUMENT	
	OPEN posn	INT posn	CLOSE posn	1 NO. --- 1 NO.
	CONTACT TYPE		SPDT 2 NO + 2 NC	
	RATING (AC / DC)		5A 240V AC AND 0.2A 220V DC	
	ENCLOSURE CLASS		<input checked="" type="checkbox"/> IP 65	
POSITION TRANSMITTER (IN BUILT IN SMART POSITIONER)	MFR. & MODEL NUMBER		NOT APPLICABLE	
	TYPE		<input checked="" type="checkbox"/> Electronic (2-Wire Type),Non-Contact Type <input type="checkbox"/> OTHER	
	SUPPLY		<input checked="" type="checkbox"/> 24V DC <input type="checkbox"/> 220V DC <input type="checkbox"/> 110V AC <input type="checkbox"/> 240V AC	
	OUTPUT RATING		<input checked="" type="checkbox"/> 4-20mA <input type="checkbox"/> 0-100 ohms	
	ACCURACY		± 1% FS	
	ENCLOSURE CLASS		<input checked="" type="checkbox"/> IP 65	
SOLENOID VALVE	MFR. & MODEL NUMBER		TO BE INDICATED IN VENDOR'S DOCUMENT	
	RATING		<input checked="" type="checkbox"/> 24V DC <input type="checkbox"/> 220V DC <input type="checkbox"/> 240V AC <input type="checkbox"/>	
	OPERATION	QUANTITY	<input type="checkbox"/> Stayput <input checked="" type="checkbox"/> Interlock	AS PER DATASHEET & HOOK UP
	COIL INSULATION CLASS		CLASS - H	
	ENCLOSURE CLASS		<input checked="" type="checkbox"/> IP 65	
HANDWHEEL	ORIENTATION		<input type="checkbox"/> TOP MOUNTED <input checked="" type="checkbox"/> SIDE MOUNTED	
JUNCTION BOX (Galvanized sheet steel, thickness not less than 2mm.)	NO. OF WAYS		<input type="checkbox"/> 24-WAYS <input checked="" type="checkbox"/> 36-Ways <input type="checkbox"/> AS REQUIRED	
	SIZE		AS REQUIRED	
	CABLE GLANDS (Size / Quantity)		AS REQUIRED (Double Compression Type).	
	ENCLOSURE CLASS		<input checked="" type="checkbox"/> IP 65	
I/P CONVERTER	MFR. & MODEL NUMBER		IN BUILT IN SMART POSITIONER	
	INPUT SIGNAL	POWER SUPPLY		
	SPLIT RANGE			
	ENCLOSURE CLASS			
SS Tubing & Fittings / per CV	This is in addition to SS Tubing and fittings which are integral part of CV		12 Meters of ¼" SS Tubing, with 1 set of SS Fittings for each CV for connection to IA Header on one end and accessories on another end of CV.	
				COMPANY SEAL
				NAME
				SIGNATURE
				DATE



Technical specification for
Control Valves with Accessories
(Pneumatically Operated)

SPEC NO.: PE-TS-415-145-I801

DOCUMENT NO.

VOLUME II B

SECTION C

ISSUE NO. 2

REV. NO. 00

DATE 10.01.2020

SECTION-C
DATASHEET C



Technical specification for
Control Valves with Accessories
(Pneumatically Operated)

SPECIFICATION NO. **PE-TS-415-145-1801**

DOCUMENT NO.

VOLUME IIB

SECTION **C**

ISSUE NO. 2

REV. NO. 00

DATE: 10.01.2020

Tag No..... Quantity.....

Data Sheet No. PES-145-06-DS2-1

DATA SHEET C

DATA SHEET – C FOR CONTROL VALVE (WITH PNEUMATIC ACTUATOR)
(TO BE FILLED BY THE BIDDER AFTER THE AWARD OF CONTRACT)

GENERAL*	PROJECT	
	SERVICE	
	LOCATION	
	DUTY	
	PIPE SIZE (inlet / outlet)	
	PIPE MATERIAL (inlet / outlet)	
BODY	MODEL NUMBER	
	TYPE OF BODY : GUIDING : NO. OF PORTS	
	BODY SIZE : PORT SIZE : DESIGN CV	
	END CONNECTION & RATING (ANSI)	
	BODY MATERIAL	
	PACKING MATERIAL SINGLE / DOUBLE	
	BONNET TYPE	
	TRIM FORM	
	TRIM MATERIAL : SEAT PLUG	
	TRIM MATERIAL : CAGE GUIDE	
	FLOW	
	OUTLET VELOCITY	
	REQUIRED LEAKAGE CLASS	
	NOISE LEVEL (dBA)	
VACUUM SERVICE		
ANTI CAVITATION TRIM		
PNEUMATIC ACTUATOR	MODEL NO. & SIZE	
	CLOSE AT : OPEN AT (Kg / Cm ² g)	
	*TRAVEL TIME FOR OPEN TO CLOSE, CLOSE TO OPEN	
	*VALVE POSN. ON SIGNAL AIR FAILURE	
	*VALVE POSN. ON SUPPLY AIR FAILURE	
ACCESSORIES	POSITIONER(SMART)	
	AIR FILTER REGULATOR	
	AIR LOCK RELAY	
	POSITION LIMIT SWITCH	
	POSITION TRANSMITTER	
	SOLENOID VALVE	
	E / P CONVERTER	
	JUNCTION BOX	
	HAND WHEEL (SIDE MOUNTED)	
	LOCAL POSITION INDICATOR	



Technical specification for
Control Valves with Accessories
(Pneumatically Operated)

SPECIFICATION NO. **PE-TS-415-145-1801**

DOCUMENT NO.

VOLUME IIB

SECTION **C**

ISSUE NO. 2

REV. NO. 00

DATE: 10.01.2020

Tag No..... Quantity.....

Data Sheet No. PES-145-06-DS2-1

DATA SHEET C

DATA SHEET – C FOR CONTROL VALVE (WITH PNEUMATIC ACTUATOR)
(TO BE FILLED BY THE BIDDER AFTER THE AWARD OF CONTRACT)

PERFORMANCE OF VALVE	HYSTERSIS								
	LINEARITY								
	SENSITIVITY								
	ACCURACY (Overall)								
SERVICE CONDITION*	SL.+ NO.	LOAD	FLOW (T/HR)	INLET PR. (KG/CM ² (A))	OUTLET PR. (KG/CM ² (A))	TEMP DEG. C	CALCULATED CV	% VALVE LIFT	VALVE O/L VELOCITY
	VALVE TYPE								
	* MAX SHUT OFF PRESS ((KG/CM ² g)								
	* BODY DESIGN : PRESS ((KG/CM ² g) TEMP (DEG. C)								
	* IBR FORM III-C								
TOTAL WEIGHT (VALVE + ACTUATOR + ACCESSORIES) KG.									
SEA WORTHY PACKING APPLICABLE / NOT APPLICABLE									



**Technical specification for
Control Valves with Accessories
(Pneumatically Operated)**

SPECIFICATION NO.: **PE-TS-415-145-I801**

DOCUMENT NO.:

VOLUME **II-B**SECTION **C**

ISSUE NO. 2

REV. NO. 00

DATE: 10.01.2020

Tag No..... Quantity.....

Data Sheet No. PES-145-06-DS2-1

DATA SHEET C FOR ACCESSORIES

**DATA SHEET – C FOR CONTROL VALVE (WITH PNEUMATIC ACTUATOR)
(TO BE FILLED BY THE BIDDER AFTER THE AWARD OF CONTRACT)**

POSITIONER	MFR. & MODEL NUMBER		
	BYPASS	GAUGES	ENCL. CLASS
	INPUT SIGNAL (Kg / Cm ²)		
	OUTPUT SIGNAL (Kg / Cm ²)		
AIR FILTER REGULATOR	MFR. & MODEL NUMBER		
	AIR SUPPLY PRESS (Kg / Cm ² g)		
	OUTPUT PRESS (Kg / Cm ² g)		
	OUTPUT GAUGE		
	FILTER SIZE		
AUTO DRAIN FEATURE			
AIR LOCK	MFR. & MODEL NUMBER		
	SET PRESS (Kg / Cm ²)		
	SUPPLY PRESS (Kg / Cm ²)		
	RESET TYPE		
	VENT PLUG		
LIMIT SWITCH	MFR. & MODEL NUMBER		
	OPEN posn	INT posn	CLOSE posn
	CONTACT TYPE		
	RATING (AC / DC)		
	ENCLOSURE CLASS		
POSITION TRANSMITTER	MFR. & MODEL NUMBER		
	TYPE		
	SUPPLY		
	OUTPUT RATING		
	ACCURACY		
	ENCLOSURE CLASS		
SOLENOID VALVE	MFR. & MODEL NUMBER		
	RATING		
	OPERATION	QUANTITY	
	COIL INSULATION CLASS		
	ENCLOSURE CLASS		
HANDWHEEL	ORIENTATION		
JUNCTION BOX	NO. OF WAYS		
	SIZE		
	CABLE GLANDS (Size / Quantity)		
	ENCLOSURE CLASS		
	BODY MATERIAL		
I/P CONVERTER	INPUT SIGNAL	POWER SUPPLY	
	SPLIT RANGE		
	ENCLOSURE CLASS		
	LINEARITY		
	HYSTERISIS		
Cu./SS Tubing & Fittings / per CV	15 Meters of ¼ " PVC coated SS Tubing, with 1 set of Fittings for each CV for connection to IA Header on one end and accessories on another end of CV.		
PAINTING	COLOUR/SHADE		
	THICKNESS (DFT)		
	TYPE		
			COMPANY SEAL
			NAME
			SIGNATURE
			DATE



Technical specification for
Control Valves with Accessories
(Pneumatically Operated)

SPECIFICATION NO. **PE-TS-415-145-1801**

DOCUMENT NO. PE-QP-999-145-I006

VOLUME **II-B**SECTION **C**

ISSUE NO. 2

REV. NO. 00

DATE : 10.01.2020

SECTION-C
QUALITY PLAN



QUALITY PLAN FOR CONTROL VALVE (PNEUMATIC)

QUALITY PLAN NO.: PE-QP-415-145-I 006		
VOLUME	IIB	
SECTION	C	
ISSUE NO. 2	REV. NO. 3	DATE: 06.12.18
SHEET 2	OF	7

Sl. No.	Component / operation	Characteristics Checked	* Category	Type/Method of Check	Extent of Check	Reference documents	Acceptance Norms	Format of Records	Agency \$			Remarks
									P	W	V	
1.0 INCOMING MATERIAL												
1.1	Body & Bonnet casting / forgings, plug, valve stem, seat ring/cage.	1. Physical, Chemical properties	MA	Physical, Chemical tests	One/ Heat(HT Batch)	Approved drg. / data sheet /	Approved drg. / data sheet /	Test Certificate	3	---	2,1	TC for body/bonnet from foundry only
		2. Heat Treatment	MA	Review of H.T. Chart	Each H.T.	Approved drg. / data sheet /	Approved drg. / data sheet /	Test Certificate	3/2	2	1	1.IBR Certification (if applicable) to be verified by BHEL. 2.Applicable for body /bonnet only
		3. Internal quality of castings	MA	RT for Body & UT for Bonnet	100%	ASME B 16.34	ASME B 16.34	Test Report / FILM	3/2	2	1	Applicable for body and bonnet for rating ANSI 900 and above.
		4. Surface Quality	MA	1. Visual	100%	MSS-SP-55	MSS-SP-55	Test Certificate	3/2	---	2	
				2. MT/PT	100%	ASME B 16.34	ASME B 16.34	Test Certificate	3	2	1	After Machining on machined surface only
		5. Pressure test for shell	MA	Hyd. Test	100%	ISA-S-75.19/ ASME B 16.34	ISA-S-75.19/ ASME B 16.34	Test Certificate	2	2	1	For Body & Bonnet after machining.
1.2	Diaphragm	1. Surface Quality	MA	Visual	100%	Mfr. standard	Mfr. standard	Test Certificate	3/2	---	2,1	

LEGEND: * CR - Critical characteristics
MA - Major characteristics
MI - Minor characteristics

RT- Radiographic Test
UT - Ultrasonic Test

PT - Dye penetrant Test
MT- Magnetic Test

\$ P - Agency Performing the Test.
W - Agency Witnessing the Test.
V - Agency Verifying the Test.

1 - BHEL 4-MAHAGENCO
2 - Vendor
3 - Sub-vendor





QUALITY PLAN FOR CONTROL VALVE (PNEUMATIC)



QUALITY PLAN NO.: **PE-QP-415-145-I 006**

VOLUME IIB

SECTION C

ISSUE NO. 2 REV. NO. 3 DATE: 06.12.18

SHEET 3 OF 7

Sl. No.	Component / operation	Characteristics Checked	* Category	Type/Method of Check	Extent of Check	Reference documents	Acceptance Norms	Format of Records	Agency [§]			Remarks
									P	W	V	
		2. Hardness	MA	Measurement	100%	Mfr. standard	Mfr. standard	Test Certificate	3/2	---	2,1	
		3. Endurance / Life cycle	MA	Cyclic test 10,000 cycles	One / Type	10,000 cycles/ Mfr. standard.	No damage	Test Certificate	3/2	---	2,1	
1.3	Spring	1. Composition	MA	Chemical-Analysis	One sample/ Heat	Material spec. / Mfr. standard	Material spec. / Mfr. standard	Test Certificate	3	---	2,1	
		2. Mech. Properties	MA	Mech. Test	One sample/ Heat	Material spec. / Mfr. standard	Material spec. / Mfr. standard	Test Certificate	3	---	2,1	
		3. Performance	MA	1. Stiffness ratio	100%	Material spec. / Mfr. standard	Material spec. / Mfr. standard	Test Certificate	3	---	2,1	
				2. Scragging	100%	Material spec. / Mfr. standard	Material spec. / Mfr. standard	Test Certificate	3	---	2,1	
				3. Cyclic test (Endurance)	One / type	10,000 cycles	Material spec. / Mfr. standard	Test Certificate	3	---	2,1	
4. Dimension (Measurement)	One sample/ Lot	Mfr. standard	Mfr. standard	Record	3	---	2,1					
1.4	Electrical items [Limit switches, Solenoids, Position Transmitter(if provided externally)]	1. Routine Test	MA	HV, IR, Continuity function	100%	Relevant Standards	Relevant Standards	Test Certificate	3	---	2,1	
		2. Degree of protection	MA	IP/NEMA Tests	One sample / type	Approved Data sheet	Approved Data sheet	Test Certificate	3	---	2,1	

LEGEND: * CR - Critical characteristics
MA - Major characteristics
MI - Minor characteristics

RT- Radiographic Test
UT - Ultrasonic Test

PT - Dye penetrant Test
MT- Magnetic Test

[§] P - Agency Performing the Test.
W - Agency Witnessing the Test.
V - Agency Verifying the Test.

1 - BHEL 4-MAHAGENCO
2 - Vendor
3 - Sub-vendor



QUALITY PLAN FOR CONTROL VALVE (PNEUMATIC)

QUALITY PLAN NO.: **PE-QP-415-145-I 006**

VOLUME IIB

SECTION C

ISSUE NO. 2 REV. NO. 3 DATE: 06.12.18 ;

SHEET 4 OF 7

Sl. No.	Component / operation	Characteristics Checked	* Category	Type/Method of Check	Extent of Check	Reference documents	Acceptance Norms	Format of Records	Agency \$			Remarks
									P	W	V	
1.5	Pressure Gauges	1. Performance	MA	Review of calibration certificates	100%	Mfr. Standard	Mfr. Standard	Test Certificate	3	---	2,1	
		2. Marking	MA	Visual	100%	Mfr. standard	Mfr. standard	Records	3	---	2,1	
2.0	IN PROCESS INSPECTION											
2.1	After machining, i Body ii Bonnet iii Plug iv Valve Stem v seat ring/cage	1. Surface flaws	MA	Visual & MT/PT	100% (on accessible surfaces)	ASME B 16.34	ASME B 16.34	Test Records	2	---	1	Butt weld ends shall be included.
		2. Dimensional checks	MA	Measurement	100%	Mfr. Standard	Mfr. Standard	Records	2	---	1	
		3. Hard facing (wherever applicable)	MA	Hardness Measurement	One sample/Lot	Mfr. Standard	Mfr. Standard	Records	2	---	1	
3.0	TESTS ON COMPLETED VALVE											
3.1	Actuator Chamber	Leakage & Strength	MA	Pneumatic test	100%	Mfr. Standard	No Leakage	Test Certificate	2	1	1	Refer Note-4
3.2	Body	Leakage and Pressure test (Body Mount Leakage)	MA	Hydro test	100%	ISA - S-75.19/ ASME B16.34	No Leakage	Test Certificate	2	1,4	1	Refer Note-4
3.3	Seat leakage test for completed valve	Seat Leakage	MA	Pneumatic Test	100%	FCI-70.2	FCI-70.2	Test Certificate	2	1,4	1	Refer Note-4
4.0	OPERATION TEST ON COMPLETED VALVE (Final inspection)	1. Valve Travel	MA	Measurement	100%	Mfr. Procedure	Approved drg. / data sheet	Test Report	2	1,4	1	Refer Note-4
		2. Opening/Closing time	MA	Measurement	100%	Mfr. Procedure	Approved drg. / data sheet	Test Report	2	1,4	1	Refer Note-4
		3. Linearity/cam characteristic	MA	Measurement	100%	Mfr. Procedure	Approved drg. / data sheet	Test Report	2	1,4	1	Refer Note-4

LEGEND: * CR - Critical characteristics
MA - Major characteristics
MI - Minor characteristics

RT- Radiographic Test
UT - Ultrasonic Test
PT - Dye penetrant Test
MT- Magnetic Test

\$ P - Agency Performing the Test.
W - Agency Witnessing the Test.
V - Agency Verifying the Test.

1 - BHEL 4-MAHAGENCO
2 - Vendor
3 - Sub-vendor



QUALITY PLAN FOR CONTROL VALVE (PNEUMATIC)

QUALITY PLAN NO.: PE-QP-415-145-I 006		
VOLUME	IIB	
SECTION	C	
ISSUE NO. 2	REV. NO. 3	DATE: 06.12.18 ;
SHEET 5	OF 7	

Sl. No.	Component / operation	Characteristics Checked	* Category	Type/Method of Check	Extent of Check	Reference documents	Acceptance Norms	Format of Records	Agency \$			Remarks
									P	W	V	
		4. Repeatability	MA	Measurement	100%	Mfr. Procedure	Approved drg. / data sheet	Test Report	2	1,4	1	Refer Note-4
		5. Hysteresis	MA	Measurement	100%	Mfr. Procedure	Approved drg. / data sheet	Test Report	2	1,4	1	Refer Note-4
		6. Sensitivity	MA	Measurement	100%	Mfr. Procedure	Approved drg. / data sheet	Test Report	2	1,4	1	Refer Note-4
		7. Accuracy (Overall)	MA	Measurement	100%	Mfr. Procedure	Approved drg. / data sheet	Test Report	2	1,4	1	Refer Note-4
		8. Control Valve characteristics / CV Test	MA	♦ Measurement (Press. vs. discharge and discharge vs. opening 0-100% in steps of 10%)	100%	Mfr. Procedure	Approved drg. / data sheet	Test Certificate	2	1,4	1	♦ Size = Body & port size Or Body size & CV for non std port. Refer Note 1.
		9. Operation of limit switch & solenoids and other accessories	MA	Function	100%	Mfr. Procedure	Approved drg./ data sheet	Test Report	2	1,4	1	On assembled valve Refer Note-4
		10. Overall dimensions	MI	Visual and dimensional	100%	Approved drg. / data sheet	Approved drg./ data sheet	Records	2	1,4	1	Refer Note-4
		11. Pre defined valve position in case of air failure	MA	Visual	100%	Approved drg. / data sheet	Approved drg. / data sheet	Test Certificate	2	1,4	1	
		12. Cleanliness, painting, stamping (for direction of flow), Tag No.	MA	Visual and dimensional, paint thickness	100%	Mfr. Procedure	Approved drg./ data sheet	Test Certificate	2	1,4	1	
		13. Surface Quality	MA	Visual	100%	MSS-SP-55	MSS-SP-55	Test Certificate	3/2	---	2,1	

LEGEND: * CR - Critical characteristics RT- Radiographic Test PT – Dye penetrant Test \$ P - Agency Performing the Test. 1 - BHEL 4-MAHAGENCO
 MA - Major characteristics UT – Ultrasonic Test MT- Magnetic Test W - Agency Witnessing the Test. 2 - Vendor
 MI - Minor characteristics V - Agency Verifying the Test. 3 - Sub-vendor



QUALITY PLAN FOR CONTROL VALVE (PNEUMATIC)

QUALITY PLAN NO.: **PE-QP-415-145-I 006**

VOLUME IIB

SECTION C

ISSUE NO. 2 REV. NO. 3 DATE: 06.12.18 ;

SHEET 6 OF 7

Sl. No.	Component / operation	Characteristics Checked	* Category	Type/Method of Check	Extent of Check	Reference documents	Acceptance Norms	Format of Records	Agency \$			Remarks
									P	W	V	
5.0	AUXILIARY ITEMS (Performance test of auxiliary items shall be performed on the completely assembled valve)											
5.1	Positioner	Overall leakage after assembly including Nozzles leakage	MA	Leak Test (in the steady state input signal)	100 %	Mfr. Standard	No leakage	Test Certificate	3/2	---	1	Certificate of Conformance (C.O.C)
5.2	Air filter regulator	1. Normal air consumption	MA	Measurement	Each type	Mfr. Standard	No leakage	Test Certificate	3/2	---	1	(C.O.C)
		2. Overall leakage	MA	Visual (soap solution)	100 %	Mfr. Standard	No leakage	Test Certificate	3/2	---	1	(C.O.C)
5.3	Air lock relay	Performance Test	MA	Leakage test	100%	Mfr. Standard	No leakage	Test Certificate	3/2	---	1	(C.O.C)
5.4	Electronic position transmitter(not applicable if provided integral to smart positioner)	1. Accuracy	MA	Operation	100%	Approved data sheet /	Approved data sheet /	Test Certificate	2	1	1	(C.O.C)
5.5	Current to Pneumatic converter(not applicable for smart positioner)	1. Physical Verification Make/Model	MA	Visual	100%	Approved drg. / data sheet	Approved drg. / data sheet	Test Certificate	2	---	1	(C.O.C)
		2. Degree of Protection	MA	IP/NEMA test	Each type	Relevant Standard	Relevant Standard	Test Certificate	3	---	1	(C.O.C)
		3. Linearity	CR	Measurement	100%	Approved drg. / data sheet /	Approved drg. / data sheet /	Inspection Report	2	---	1	(C.O.C)
		4. Hysterisis	CR	Measurement	100%	Approved drg. / data sheet /	Approved drg. / data sheet /	Inspection Report	2	---	1	(C.O.C)
5.6	Smart Positioner	1. Physical Verification Make/Model	MA	Visual	100%	Approved drg. / data sheet	Approved drg. / data sheet	Test Certificate	2	---	1	(C.O.C)



LEGEND: * CR - Critical characteristics
MA - Major characteristics
MI - Minor characteristics

RT- Radiographic Test
UT - Ultrasonic Test

PT - Dye penetrant Test
MT- Magnetic Test

\$ P - Agency Performing the Test.
W - Agency Witnessing the Test.
V - Agency Verifying the Test.

1 - BHEL 4-MAHAGENCO
2 - Vendor
3 - Sub-vendor



QUALITY PLAN FOR CONTROL VALVE (PNEUMATIC)

QUALITY PLAN NO.: **PE-QP-415-145-I 006**

VOLUME IIB

SECTION C

ISSUE NO. 2 REV. NO. 3 DATE: 06.12.18

SHEET 7 OF 7

Sl. No.	Component / operation	Characteristics Checked	* Category	Type/Method of Check	Extent of Check	Reference documents	Acceptance Norms	Format of Records	Agency \$			Remarks
									P	W	V	
	(As Applicable)	2. Degree of Protection	MA	IP/NEMA test	Each type	Relevant Standard	Relevant Standard	Test Certificate	3	---	1	(C.O.C)
		3. Linearity	CR	Measurement	100%	Approved drg. / data sheet /	Approved drg. / data sheet /	Inspection Report	2	---	1	(C.O.C)
		4. Hysterisis	CR	Measurement	100%	Approved drg. / data sheet /	Approved drg. / data sheet /	Inspection Report	2	---	1	(C.O.C)
		5. Calibration with Hand Held Communicator	MA	Measurement	Each type	Mfr. Standard	Mfr. Standard	Test Certificate	2	---	1	(C.O.C)
6.0	PAINTING	Soundness of Painting	MA	Visual and Measurement	100%	Mfr. Standard	Mfr. Standard	Inspection Report	2	---	---	Refer Note-2
7.0	PACKING	Soundness of Packing against transit damage	MA	Visual	100%	Mfr. Standard	Mfr. Standard	Inspection Report	2	---	---	Refer Note-3

NOTES:

- In case valid CV test certificate for a similar control valve (same size, same CV, same trim characteristics) is not submitted to BHEL by the vendor, CV test shall be conducted at FCRI/Any govt. approved laboratory/ BHEL approved Laboratory.
- In the absence of BHEL spec. for painting, vendor to obtain BHEL's approval on their painting specification / procedure.
- Sea worthy packing shall be provided, if called for in the Data sheets.
- The quantum of check shall be 100% for manufacturer and 100% for Customer/BHEL/BHEL nominated inspection agency.
- IBR certificates in Form III-C shall be submitted if called for in the specification/datasheet.
- Copies of all TC's (Test Certificates) for materials duly correlated with Heat Nos., TC's for electrical items and mechanical tests (Leak/Operation), C.O.C's (Certificates of Conformance) shall be submitted to BHEL for verification and acceptance.

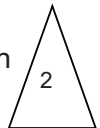

LEGEND: * CR - Critical characteristics RT- Radiographic Test PT - Dye penetrant Test \$ P - Agency Performing the Test. 1 - BHEL 4-MAHAGENCO
 MA - Major characteristics UT - Ultrasonic Test MT- Magnetic Test W - Agency Witnessing the Test. 2 - Vendor
 MI - Minor characteristics V - Agency Verifying the Test. 3 - Sub-vendor



Technical specification for
Control Valves with Accessories
(Pneumatically Operated)

SPEC NO.: **PE-TS-415-145-I801**

DOCUMENT NO.

VOLUME II B

SECTION C

ISSUE NO. 2

REV. NO. 00

DATE 10.01.2020

SECTION – C

BILL OF QUANTITY-MAIN SUPPLY

	Technical specification for Control Valves with Accessories (Pneumatically Operated)	SPEC NO.: PE-TS-415-145-I801	
		DOCUMENT NO.	
		VOLUME	II B
		SECTION	C
		ISSUE NO.	2
REV. NO.	00	DATE	10.01.2020

BILL OF QUANTITY-MAIN SUPPLY

**CONTROL VALVES COMPLETE WITH POSITIONER AND ALL ACCESSORIES MOUNTED,
TUBED AND TERMINATED ON JB**

[A]	MAIN SUPPLY		
SR. NO.	TAG NO	DESCRIPTION	TOTAL QTY
1	ASV-8	D/A Pegging from Aux. Steam Header	1
2	CRHV-6	D/A Pegging from CRH Line	1
3	CDV-22	Main Condensate Control	1
4	CDV-25	Main Condensate Control	1
5	CDV-39	GSC & CEP min. flow recirculation	1
6	CDV-43	Excess Dump Control	1
7	CDV-72	Condensate for Valve Gland Sealing	1
8	DRV-8	HPH-7 Drain to HPH-6	1
9	DRV-11	HPH-7 ALT Drain to Flash tank B	1
10	DRV-15	HPH-6 Drain to Deaerator	1
11	DRV-18	HPH-6 Drain to Flash tank-A	1
12	DRV-28	LPH-3 Drain to LPH-2	1
13	DRV-31	LPH-3 Drain to Flash tank-B	1
14	DRV-34	LPH-2 Drain to LPH-1	1
15	DRV-37	LPH-2 Drain to Flash Tank-B	1
16	DRV-48	Deaerator overflow to Flash tank-B	1
17	DRV-2	HPH-8 drain to HPH-7	1
18	DRV-5	HPH-8 alternate drain to Flash Tank-A	1
19	DRV-65	LPH-4 Drain to LPH-3	1
20	DRV-68	LPH-4 Alternate drain to Flash Tank-B	1
21	DMV-50	DM MU to Hotwell High Capacity	1
22	DMV-47	DM MU to Hotwell Low Capacity	1
23	FDV-14	Low Load Feed Control	1
24	ASV-2	Aux. Steam to BFPTs	1
25	CRHV-2	CRH Steam to BFPTs	1
[B]	1/4 " SS TUBING(12 METER FOR EACH TAG)		300 METER
[C]	SS FITTINGS- FOR EACH TAG		1 LOT
1	SS FITTINGS for connection to Air Filter Regulator- FOR EACH TAG		1 LOT
2	SS FITTINGS for connection to Air Lock Relay- FOR EACH TAG		1 LOT
3	SS FITTINGS for connection to IA Header Isolation Valve - FOR EACH TAG		1 LOT
4	SS EQUAL TEE - FOR EACH TAG		1 LOT
5	SS 1/2 " NPT(M) X 1/4 " OD TUBE CONNECTOR- FOR EACH TAG		1 LOT
[D]	CV TEST CHARGES FOR EACH CONTROL VALVE		1 LOT
[E]	VALVE DIAGNOSTIC AND CONFIGURATION SOFTWARE (FOR ALL TAGS)		1 LOT
[F]	HAND HELD CALIBRATOR		1 NO



Technical specification for
Control Valves with Accessories
(Pneumatically Operated)

SPEC NO.: PE-TS-415-145-I801

DOCUMENT NO.

VOLUME II B

SECTION C

ISSUE NO. 2

REV. NO. 00

DATE 10.01.2020

CV TEST CHARGES

SR. NO.	TAG NO	DESCRIPTION	TOTAL QTY
1	ASV-8	D/A Pegging from Aux. Steam Header	1
2	CRHV-6	D/A Pegging from CRH Line	1
3	CDV-22	Main Condensate Control	1
4	CDV-25	Main Condensate Control	1
5	CDV-39	GSC & CEP min. flow recirculation	1
6	CDV-43	Excess Dump Control	1
7	CDV-72	Condensate for Valve Gland Sealing	1
8	DRV-8	HPH-7 Drain to HPH-6	1
9	DRV-11	HPH-7 ALT Drain to Flash tank B	1
10	DRV-15	HPH-6 Drain to Deaerator	1
11	DRV-18	HPH-6 Drain to Flash tank-A	1
12	DRV-28	LPH-3 Drain to LPH-2	1
13	DRV-31	LPH-3 Drain to Flash tank-B	1
14	DRV-34	LPH-2 Drain to LPH-1	1
15	DRV-37	LPH-2 Drain to Flash Tank-B	1
16	DRV-48	Deaerator overflow to Flash tank-B	1
17	DRV-2	HPH-8 drain to HPH-7	1
18	DRV-5	HPH-8 alternate drain to Flash Tank-A	1
19	DRV-65	LPH-4 Drain to LPH-3	1
20	DRV-68	LPH-4 Alternate drain to Flash Tank-B	1
21	DMV-50	DM MU to Hotwell High Capacity	1
22	DMV-47	DM MU to Hotwell Low Capacity	1
23	FDV-14	Low Load Feed Control	1
24	ASV-2	Aux. Steam to BFPTs	1
25	CRHV-2	CRH Steam to BFPTs	1



Technical specification for
Control Valves with Accessories
(Pneumatically Operated)

SPEC NO.: **PE-TS-415-145-I801**

DOCUMENT NO.

VOLUME II B

SECTION C

ISSUE NO. 2

REV. NO. 00

DATE 10.01.2020

SECTION – C

BILL OF QUANTITY-SPARES

	Technical specification for Control Valves with Accessories (Pneumatically Operated)	SPEC NO.: PE-TS-415-145-I801	
		DOCUMENT NO.	
		VOLUME	II B
		SECTION	C
		ISSUE NO.	2
REV. NO.	00	DATE	10.01.2020

LIST OF COMMISSIONING SPARES

S NO	ITEM DESCRIPTION	QUANTITY FOR STATION
1	Gaskets	One(1) set with each control valve tag
2	Gland Packing	One(1) set with each control valve tag

LIST OF MANDATORY SPARES

A NON CRITICAL CONTROL VALVES

Sr. No.	Description	Qty FOR STATION
1	Complete actuator for each type and model	1 complete actuator of each type/size/model or min 10% of each type/size whichever is more
2	Diaphragms, O' rings, seals etc. of all types make etc.	2 nos for each control valve.
3	Gasket	2 nos for each type/size of control valve.
4	Lubricant	100 % qty of lubricants for gaskets for each control valve on one year consumption basis
5	Limit Switches	2 set for each control valve.
6	Volume Booster.	2 nos. of each type and size
7	Stem Packing	1 set for each control valve.
8	Solenoid valves	10% or 2 nos. of each type whichever is more
9	Positioner units/smart positioners (complete unit)& accessories (link assembly)	10% or 2 no. of each type whichever is more
10	Pneumatic air-filter/Regulator	2 Nos. of each type, make rating etc.
11	Air lock relays	4 nos. of each type
12	Valve trim (including cage, plug, stem, seat rings, guide bushings, stem lock pins, packing, retaining rings etc.)	1 set for each control valve.

	Technical specification for Control Valves with Accessories (Pneumatically Operated)	SPEC NO.: PE-TS-415-145-I801	
		DOCUMENT NO.	
		VOLUME	II B
		SECTION	C
		ISSUE NO.	2
REV. NO.	00	DATE	10.01.2020

B CRITICAL CONTROL VALVE FDV14

Sr. No.	Description	Qty FOR STATION
1	Complete actuator for each type and model	1 complete actuator of each type/size/model or min 10% of each type/size whichever is more
2	Diaphragms, O' rings, seals etc. of all types make etc.	2 nos for each control valve.
3	Soft good Kit valve	1 set for each control valve.
4	Actuator soft goods kit	1 set for each control valve.
5	Metal seat	1 nos
6	Volume Booster.	2 nos. of each type and size
7	Seat Ring	1 nos
8	Solenoid valves	10% or 2 nos. of each type whichever is more
9	Spindle	1 nos
10	Positioner units/smart positioners (complete unit)& accessories (link assembly)	10% or 2 no. of each type whichever is more
11	Pneumatic air-filter/Regulator	2 Nos. of each type, make rating etc.
13	Air lock relays	4 nos. of each type
13	Valve trim (including cage, plug, stem, seat rings, guide bushings, stem lock pins, packing, retaining rings etc.)	1 set for each control valve.



Technical specification for
Control Valves with Accessories
(Pneumatically Operated)

SPEC NO.: PE-TS-415-145-I801

DOCUMENT NO.

VOLUME II B

SECTION C

ISSUE NO. 2

REV. NO. 00

DATE 10.01.2020

NOTE

1. Wherever quantity has been specified as percentage (%), the quantity of mandatory spares to be provided by contractor shall be the specified percentage (%) of the total population of the plant. In case the quantity so calculated happens to be a fraction, the same shall be rounded off to next higher whole number.
2. Wherever the quantities have been indicated for each type, size, thickness, material, radius, range etc., these shall cover all the items supplied and installed and the breakup for these shall be furnished in the bid. In case spares indicated in the list are not applicable to the particular design offered by the bidder, the bidder should offer spares applicable to offered design with quantities generally in line with the approach followed in the above list.



Technical specification for
Control Valves with Accessories
(Pneumatically Operated)

SPECIFICATION NO. **PE-TS-415-145-1801**

DOCUMENT NO.

VOLUME **II-B**

SECTION **D**

ISSUE NO. 2

REV. NO. 00

DATE: 10.01.2020

SECTION – D

- **EQUIPMENT SPECIFICATION
(PES-145-06)**
- **SPECIFICATION FOR SMART POSITIONER
(PES-145-06A)**
 - **HOOK-UP DIAGRAM(PES-145-06B)**
 - **GUIDELINES FOR PACKING(PES-145-06C)**
 - **SUB-VENDOR LIST**



Technical specification for
Control Valves with Accessories
(Pneumatically Operated)

SPECIFICATION NO. **PE-TS-415-145-1801**

DOCUMENT NO.

VOLUME **II-B**SECTION **D**

ISSUE NO. 2

REV. NO. 00

DATE : 10.01.2020

SECTION-D

EQUIPMENT SPECIFICATION (PES-145-06)



**SPECIFICATION FOR CONTROL VALVE
(WITH PNEUMATIC / ELECTRIC ACTUATOR)**

SPECIFICATION NO.: PE-TS-415-145-I801	
DOCUMENT NO.: PES – 145 - 06	
VOLUME	II B
SECTION	D
ISSUE NO.	2
REV. NO.	00
DATE : 10.01.2020	

1.0 SCOPE

- 1.1 This specification covers the Design, Manufacture, Inspection and Testing at the manufacturer's works, proper packing for transportation and delivery to site of Control valve (with Pneumatic/Electric Actuator as identified in the datasheet-A) for use in Utility/Captive Power Station/Combined Cycle Station.
- 1.2 Expander/Reducer between valve body & pipe shall be in BHEL's scope of supply. However, any other expander/reducer required shall be in bidder's scope of supply.

2.0 CODES AND STANDARDS

- 2.1 As a minimum requirement, the latest revision/version of the following (or equivalent) standards shall be complied as a minimum requirement :-

Indian Boiler Regulation (IBR)	
Allowable Seat leakage	: FCI-70.2
Pressure & Temperature ratings	: ANSI-B16.34
Enclosure class	: IEC-144 / NEMA / IS-13947
Control Valves Sizing	: ISA S-75
Electric Motor operated Actuators	: IS-9334

3.0 TECHNICAL REQUIREMENTS

The Control valve, Actuator and the accessories shall be suitable for continuous operation under an ambient temperature of 0-60°C and Relative Humidity of 0-95% unless specified otherwise in volume IIB Section-B or Section-C.

3.1 Control Valve

The control valve shall be suitably designed for the process operating conditions and system characteristics as specified in the Data Sheet-A.

- 3.1.1 The control valve shall be of globe/angle body design, as per datasheet, with single port. Valve trim shall be cage guided balanced type for valve sizes $\geq 3"$ and above. The valve trim shall be suitable for quick replacement without any cutting or welding. Anti-cavitation trims shall be provided for valves with cavitation service and hardened trims for flashing services.
- 3.1.2 The trim material and body material has been specified in the Datasheet-A. Bidder to offer body material and trim material combination as per the datasheet. Wherever there is a deviation from the datasheets, bidder to furnish the documentary proof for confirming superior trim material/body material selection along with their offer. BHEL/Customer reserves the right to accept/reject any variation in the specification.
- 3.1.3 Asbestos shall not be used for the packing or any other component.
- 3.1.4 The valve bonnet and packing shall be suitable for the service conditions as in Data Sheet-A. Gland sealed type bonnets are not acceptable. Double packing is mandatory for applications involving vacuum service. For valves where downstream is subjected to vacuum, flow action shall be "flow to close" (over the seat). Bonnets having Teflon packing shall have valve stem finished to 2-4 microns. Packing material requiring lubrication will not be acceptable.



**SPECIFICATION FOR CONTROL VALVE
(WITH PNEUMATIC / ELECTRIC ACTUATOR)**

SPECIFICATION NO.: PE-TS-415-145-I801

DOCUMENT NO.: PES – 145 - 06

VOLUME II B

SECTION D

ISSUE NO. 2

REV. NO. 00

DATE : 10.01.2020

Type of bonnet shall be according to the service condition. Extension bonnets shall be provided when the maximum temperature of the flowing fluid is greater than 280 or unless otherwise specified. Cast Steel (CS) yokes shall be offered for CEP Minimum Recirculation valve/GSC minimum recirculation control valve. Cast Iron (CI) yokes are not acceptable for this service.

- 3.1.5 The valve end connection as specified in Data Sheet-A shall conform to ANSI B16.25 for Butt Weld connection, ANSI B16.11 for Socket Weld connection and ANSI B16.5 for flanged ends. Tolerances on end to end, center to center, center to face shall be in accordance with ASME B16.10. The end connections shall be Socket Welded for sizes up to 50 NB and Butt Welded for sizes above 50 NB.
- 3.1.6 The valve seat leakage shall be as per FCI-70.2. The leakage class shall be as per Data Sheet-A.
- 3.1.7 The valve body shall have the direction of flow embossed on all valves.
- 3.1.8 The sizing shall conform to the requirements of ISA S75.01, and the valve capacity shall be selected so as to meet the following:
- | | | | | |
|--|---|---|---|--------------------|
| Valve with Linear Characteristic | - | Normal Flow (Design Point) | : | 70-75% valve lift. |
| | - | Max. Flow | : | 90% valve lift. |
| | - | Min. Flow | : | >10% valve lift. |
| Valve with Equipercentage Characteristic | - | Normal Flow (Design Point) | : | 75-85% valve lift. |
| | - | Max. Flow | : | 90% valve lift. |
| | - | Min. Flow | : | >10% valve lift. |
| ON/OFF Quick open Characteristic | - | 1.1 times the CV calculated on the basis of maximum flow condition. | | |
- The valve offered shall be capable of handling 120 % of the required maximum flow.
- 3.1.9 Calculation for valve sizing, velocity and noise shall be subject to purchaser's approval during contract stage. However responsibility of proper selection and design for the duties specified lies with the vendor. Any modifications required to be done on the valves or actuators & accessories to achieve satisfactory performance of the control system shall be done without any commercial & delivery implication.
- 3.1.10 The valve outlet velocities shall be limited to the following values, unless otherwise specified in the Data sheet-A.
- | | | | |
|------|------------------|----|--|
| i) | Liquid service | <= | 8 m/sec |
| ii) | Steam service | <= | 150 m/sec |
| iii) | Flashing service | <= | 50% of sonic velocity for flashing services. |
- 3.1.11 For flashing duty, trim design shall be such that the vapour bubbles are kept away from valve body.
- 3.1.12 For cavitation service, the trim design shall be of multistage pressure drop type, so as to avoid cavitation altogether, instead of keeping cavitation away from valve parts.
- 3.1.13 The equivalent weighted sound level measured at 1.5 metre above floor level in elevation and 1 metre horizontally from the control valve expressed in decibels to a reference of 0.0002 microbar shall not exceed 85 dBA (without pipe insulation). The offer shall include noise prediction calculations for each valve.



**SPECIFICATION FOR CONTROL VALVE
(WITH PNEUMATIC / ELECTRIC ACTUATOR)**

SPECIFICATION NO.: PE-TS-415-145-I801	
DOCUMENT NO.: PES – 145 - 06	
VOLUME	II B
SECTION	D
ISSUE NO.	2
REV. NO.	00
DATE : 10.01.2020	

- 3.1.14 In case of predicted noise level above 85 dBA, same shall be brought down to acceptable noise level i.e. below 85 dBA through Source treatment (proper valve trim & valve body selection). Path treatment (LNP/ Diffuser/ Cartridge/ Silencer etc.), if any shall be subject to Customer's/Owner's approval.
- 3.1.15 In case of wrong selection/mal operation of valve and for associated actuator during guarantee period, the vendor shall replace the valve suitably with a modified/new valve of design as approved by purchaser and all the expenses for replacement, rectification/modification including transportation both ways will be at vendor's expenses.
- 3.2 **ACTUATORS-** The control valves shall be operated either pneumatically (with pneumatic actuator) or electrically (with electric actuator).
For pneumatic actuator, clause nos. 3.2.1 through 3.2.6 to be followed.
- For electric actuator, please refer the technical specification for electric actuator (Refer Document No. PES-145-06D).
- 3.2.1 **Pneumatic Actuator**
- The actuator shall be designed for a thrust of 120% of valve's shut-off pressure at an airline supply pressure of 5 Kg/Sq. cm.
- The pneumatic actuators shall be employed for modulating or open/close duty, as specified in Data Sheet-A. The bidder shall be responsible for proper selection and sizing of valve actuators in accordance with the pressure drops, shut off pressure and valve travel.
The pneumatic spring opposed diaphragm actuator or piston actuator as the case may be for modulating duty shall be capable of positioning the associated valve at desired opening for all the operating conditions specified.
- 3.2.2 The pneumatic actuator for open/close duty shall be suitable for fast opening/closing of the associated valve.
- 3.2.3 The actuator design shall allow valve assembly to be mounted at 45° inclination on either side in the vertical plane.
- 3.2.4 The actuators shall be suitably sized to ensure that the associated valve travel time from full open to full closed position and vice versa is less than 10 seconds or as specified in the datasheet under the most stringent service conditions.
- 3.2.5 The actuator's hand wheel shall have OPEN & CLOSE direction marking and clockwise rotation as viewed from front shall close the valve.
- 3.2.6 Each actuator shall be provided with a mechanical pointer attached to stem, moving over a graduated scale with markings, for OPEN, 25%, 50%, 75%, CLOSE positions.
- 3.3 **Accessories for Control valve with Pneumatic Actuator**
- The bidder shall offer all the accessories as specified in the Data Sheet - A for the Pneumatic Actuators under modulating or OPEN/CLOSE duty. The accessories specified shall be supplied duly mounted on the valve actuator and piped with PVC covered copper/ SS tube and flare-less brass/ SS fittings etc. as per the hook up diagram (Refer drawing no. PES-145



**SPECIFICATION FOR CONTROL VALVE
(WITH PNEUMATIC / ELECTRIC ACTUATOR)**

SPECIFICATION NO.: PE-TS-415-145-I801	
DOCUMENT NO.: PES – 145 - 06	
VOLUME	II B
SECTION	D
ISSUE NO.	2
REV. NO.	00
DATE	: 10.01.2020

3.4 **Painting** of the control valve assembly shall be as per the Painting Specification attached elsewhere in this technical specification. In the absence of specification for painting, vendor to submit their standard painting procedure for painting for BHEL's approval. Epoxy based paint (corrosion-resistant) to be provided for control valves for coastal environment.

3.5 **Sub-vendor list –**

The sub-vendors shall be as per the list enclosed elsewhere in this specification. In case the bidder proposes sub-vendors other than those listed in the specification, the same shall be subject to BHEL's/Customer's approval.

4.0 TESTING AND INSPECTION

4.1 The testing and inspection of the equipment/items shall be in line with the approved QAP

4.2 The cost of all tests as per the approved QAP will be deemed to have been included in the bid.

4.3 In case, the bidder is supplying the valve from outside India, the third party inspection shall be arranged and considered by the bidder in their offer.

5.0 SPARES AND CONSUMABLES

5.1 Start-up/Commissioning Spares

The bidder shall supply all the start-up/commissioning spares as per the BOQ given in the technical specification.

5.2 Mandatory Spares

The bidder shall supply all the mandatory spares as per the BOQ given in the technical specification.

6.0 DRAWINGS AND DOCUMENTS

6.1 The bidder shall furnish the following documents along with the bid: 4 Sets

6.1.1 Data sheet-B, completely filled-up along with all enclosures.

6.1.2 Schedule of prices in attached format (VOL.-III).

6.1.3 Quality Plan duly signed & stamped.

6.1.4 All relevant Catalogs with detailed technical information.



**SPECIFICATION FOR CONTROL VALVE
(WITH PNEUMATIC / ELECTRIC ACTUATOR)**

SPECIFICATION NO.: PE-TS-415-145-I801	
DOCUMENT NO.: PES – 145 - 06	
VOLUME	II B
SECTION	D
ISSUE NO.	2
REV. NO.	00
DATE : 10.01.2020	

6.2 The successful bidder shall furnish the following documents to BHEL during the contract stage viz. after the award of contract:

5 sets of the following documents for approval + 2 sets of CDs:

6.2.1 CONTROL VALVE DOCUMENTS (Drg. No. PE-VO-XXX-145-I004) including the following:-

- (a) Assembly (dimensional) drawings.
- (b) Valve Edge preparation details.
- (c) Data sheet-C completely filled-up.
- (d) Hook-up diagram of Control Valve with Actuator & Accessories.
- (e) Valve & Actuator assembly dimensional drawings with weights.
- (f) All calculations like CV, Noise Level, Valve Outlet Velocity, Actuator sizing etc.
- (g) All relevant catalogues for models of the valves as well as accessories finalized.

6.2.2 QUALITY PLAN (Drg. No. PE-QP-XXX-145-I006) duly signed and stamped.

6.3 Final documentation:

Documents / drawings to be furnished by the successful bidder shall be as follows:
15 sets with 6 CD-ROMS of:-

- 6.3.1 Category I & IV approved CONTROL VALVE DOCUMENTS
- 6.3.2 Test certificates
- 6.3.3 Operation & maintenance manuals for Control Valve, Actuator and all accessories

7.0 MARKING AND PACKING

7.1 Marking

A stainless steel metal nameplate should be permanently fixed on each equipment giving its tag number and technical specifications.

7.2 Packing

All equipment / materials shall be suitably packed and protected for the entire period of dispatch, storage and erection against impact, abrasion, corrosion, incidental damage due to vermin, sunlight, high temperature, rain, moisture, humidity, dust, sea water spray (where applicable) as well as rough handling and delays in transit and storage in open. Guidelines for packing are enclosed (Refer specification no. PES-145-06C).

8.0 APPLICABLE DATA SHEET FORMS

This document shall be read with one or more of the following data sheet forms:

- Data sheet A&B for Control Valve with Pneumatic Actuator : Data sheet no. PES-145-06-DS1-1
- Data sheet C for Control Valve with Pneumatic Actuator : Data sheet no. PES-145-06-DS2-1



Technical specification for
Control Valves with Accessories
(Pneumatically Operated)

SPECIFICATION NO. **PE-TS-415-145-1801**

DOCUMENT NO.

VOLUME **II-B**SECTION **D**

ISSUE NO. 2

REV. NO. 00

DATE : 10.01.2020

SECTION-D

SPECIFICATION FOR SMART POSITIONER (PES-145-06A)

	SPECIFICATIONS FOR MICROPROCESSOR BASED ELECTRONIC POSITIONER (SMART)	SPECIFICATION NO.: PE-TS-434-145-1801	
		DOCUMENT NO.: PES-145-06A	
		VOLUME. II B	
		SECTION D	
		ISSUE NO. 2 , REV.00	DATE 18.06.2016

1.0 Electrical

Input Signal	4-20mA
Power Supply	Loop Powered from the output card of Control System (12-30 V DC)
Hart Protocol	Compatibility For Remote Calibration & Diagnostic (Super-Imposed HART Signal On Input Signal (4-20mA))
Valve Position Feedback (4-20mA)	Position Sensing 4-20mA O/P Signal For Control System To Be Provided. If non contact type of Position feedback signal is required, Position transmitter to be separately provided.

2.0 Environment

Operating Temperature	(-) 30 To 80 Deg.C
Humidity	0-95%
Protection Class	IP-65 (Minimum)

3.0 Software For Configuration & Diagnostic

Software	Windows Based Software, Software Shall Meet The Requirement For Configuration, Diagnostics, Calibration And Testing Of the Actuator. Valve positioning timing, actuator leakage, and Valve Wear & tear, fault alarm to be offered as a minimum. Easily up gradable with same hardware and compatible with any HART management systems / AMS.
Diagnostic/Test Features	Advanced Diagnostic Features Like Stroke On Line Partial Closure Test, Valve Signature Analysis (Online graphical representation , Step Response Test, Valve Friction/Jamming Detection Etc To Be Provided.

	SPECIFICATIONS FOR MICROPROCESSOR BASED ELECTRONIC POSITIONER (SMART)	SPECIFICATION NO.: PE-TS-427-145-I108	
		DOCUMENT NO.: PES-145-06A	
		SECTION D	
		ISSUE NO. 2 . REV.00	DATE 24.12.2016

Factory Valve Signature Tests Reports (Pr Vs Valve Travel And Travel Vs I/P Signal) Are To Be Provided.

Hardware PC For Configuration/Software (OPTIONAL)

Test Certificates Test Certificates As Per Manufacture Standard/Relevant Standard Are To Be Submitted.

Configuration / Remote Calibration, Auto & Manual Calibration Shall Be Possible.

4.0 Modes

Valve Action	Direct & Reverse, Valve Action. (Same positioner for Single Acting or Double Acting And no separate relays required for changing from Single acting to double).
Flow Characterization	Possible to fit valve characteristic curve linear & Equal percentage
Fail Safe/Fail Freeze (Optional)	Fail Safe/Fail Freeze feature is to be provided.

5.0 Performance

Characteristic Deviation	$\leq 0.75\%$ of span
Ambient temp effect	$\leq 0.01\%$ /Deg C or better.
Dead Band	Adjustable 0.1 to 10%.
Scan Time	10ms
Resolution	$\leq 0.05\%$
Sensitivity/Linearity	0.3-0.4% of FS
Repeatability	0.32% of FS
Auto-Tune	Yes

	SPECIFICATIONS FOR MICROPROCESSOR BASED ELECTRONIC POSITIONER (SMART)	SPECIFICATION NO.: PE-TS-427-145-I108	
		DOCUMENT NO.: PES-145-06A	
		SECTION D	
		ISSUE NO. 2., REV.00	DATE 24.12.2016

Leak Test Yes

7.0 EMC & CE compliance

Required International Standard Like EN/IEC. To En50081-2&En50082 or equivalent

8.0 Accessories

In Built Operator Panel Display With Push Buttons For Configuration And Display On The Positioner Itself

Hand Held Hart Calibrator (Optional) Universal Hart Calibrator To Be Provided, One Per Unit.

Press Gauge Block For Supply & Output Pr., Filter Regulator Other Accessories Shall Be Provided As On Required Basis For Making System Complete.

Electrical cable entry $\frac{1}{2}$ -Npt, side or bottom entry to avoid water Ingress.



Technical specification for
Control Valves with Accessories
(Pneumatically Operated)

SPECIFICATION NO. **PE-TS-415-145-1801**

DOCUMENT NO.

VOLUME **II-B**SECTION **D**

ISSUE NO. 2

REV. NO. 00

DATE : 10.01.2020

SECTION-D

HOOK-UP DIAGRAM (PES-145-06B)

CONTROL VALVE HOOK-UP DIAGRAM (WITH SMART POSITIONER)

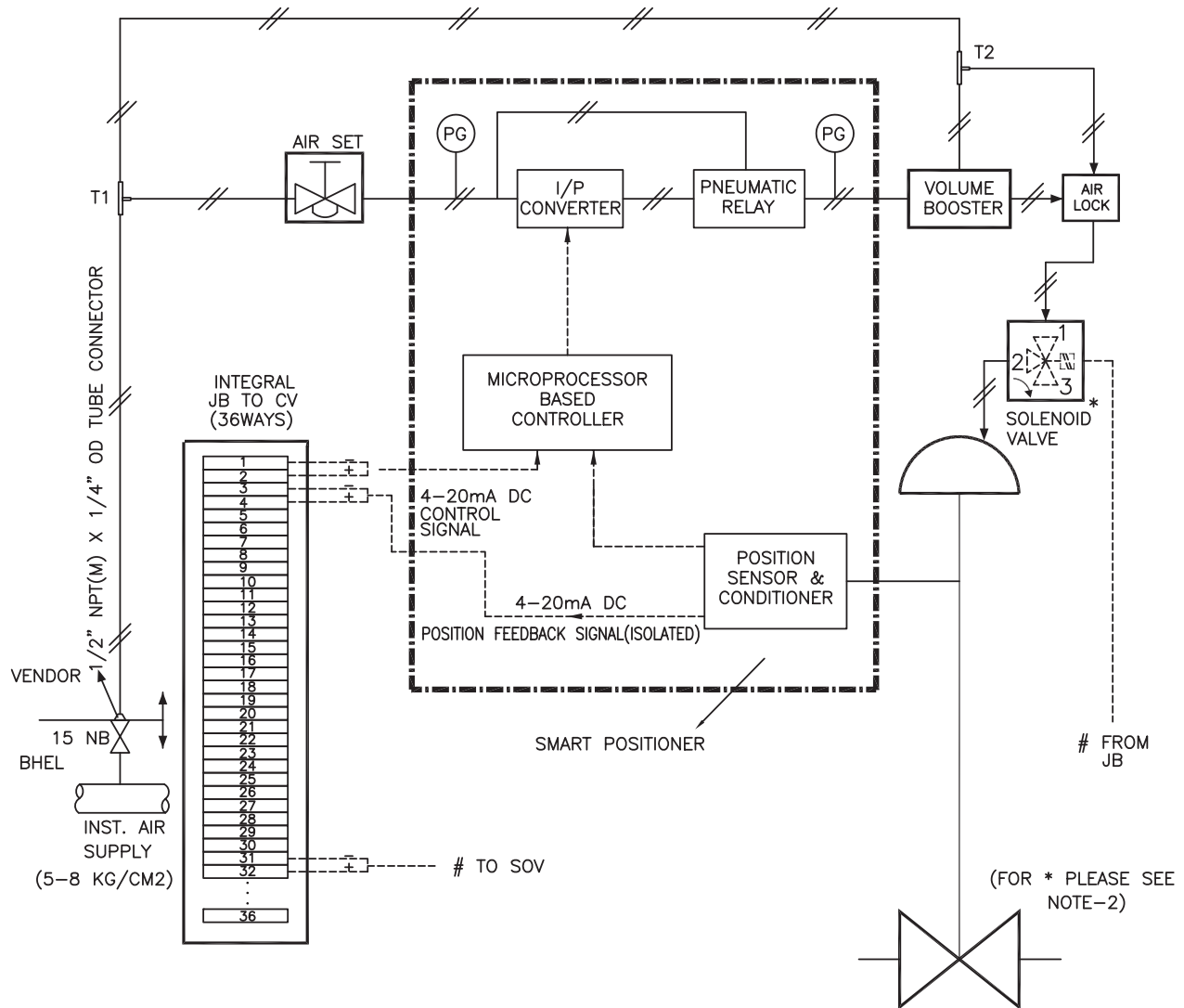

NOTES :-

1. POSITION OF EACH VALVE ON SUPPLY AIR FAILURE / ELECTRICAL SIGNAL FAILURE SHALL BE AS PER SPECIFICATION / DATA SHEET.
2. SOLENOID VALVE WILL BE PROVIDED ONLY FOR CONTROL VALVES IF INDICATED IN RESPECTIVE DATA SHEETS.
3. SOLENOID VALVES PORTS CONDITION:
PORT 1 AND 2 SHALL BE CONNECTED UNDER DE-ENERGISED CONDITION.
PORT 2 AND 3 SHALL BE CONNECTED UNDER ENERGISED CONDITION.
4. PRESSURE GAUGES REQUIRED FOR AIR SUPPLY & OUTPUT(S).
5. MOUNTING ACCESSORIES AS REQUIRED.
6. POSITION FEEDBACK SIGNAL SHALL BE 2 WIRE 4-20mA ISOLATED SIGNAL.
7. JB TERMINALS SHALL BE CAGE CLAMP TYPE SUITABLE FOR 2.5 SQ. MM COPPER WIRE. EXTERNAL CONNECTION, THROUGH CABLE GLAND, SHALL BE AS PER DATA SHEET
8. ALL APPLICABLE ACCESSORIES SHALL BE PROVIDED AS INDICATED IN THE INDIVIDUAL CONTROL VALVE DATA SHEET / ACCESSORIES DATA SHEET.
9. 12 METERS 1/4" SS TUBING (AS PER ACCESSORIES DATA SHEET) & 1 SET OF SS FITTINGS TO BE SUPPLIED FOR EACH CONTROL VALVE FOR CONNECTION TO ISO VLV AT INST AIR HEADER ON ONE END AND TO AIR LOCK RELAY/AIR FILTER REGULATOR ON THE OTHER END. ALL THE SS FITTINGS SHALL BE DOUBLE COMPRESSION TYPE.
10. VOLUME BOOSTER (ALONG WITH TEE-T2 AND RELATED TUBING & CONNECTORS) SHALL BE PROVIDED IF REQUIRED. AIR CONNECTION TO VOLUME BOOSTER FROM TEE-T2 SHALL BE PROVIDED.



1 X 660 MW BHUSAWAL STPP

TITLE:-

CONTROL VALVE HOOK-UP DIAGRAM

DRG.
No.

PE-TS-415-145-I104

REV.
No.

02

DATE

08.03.19

SHEET

48

OF

51

STANDARD CONTROL VALVE HOOK-UP DIAGRAM (DOUBLE ACTING PISTON ACTUATOR WITH SMART POSITIONER)

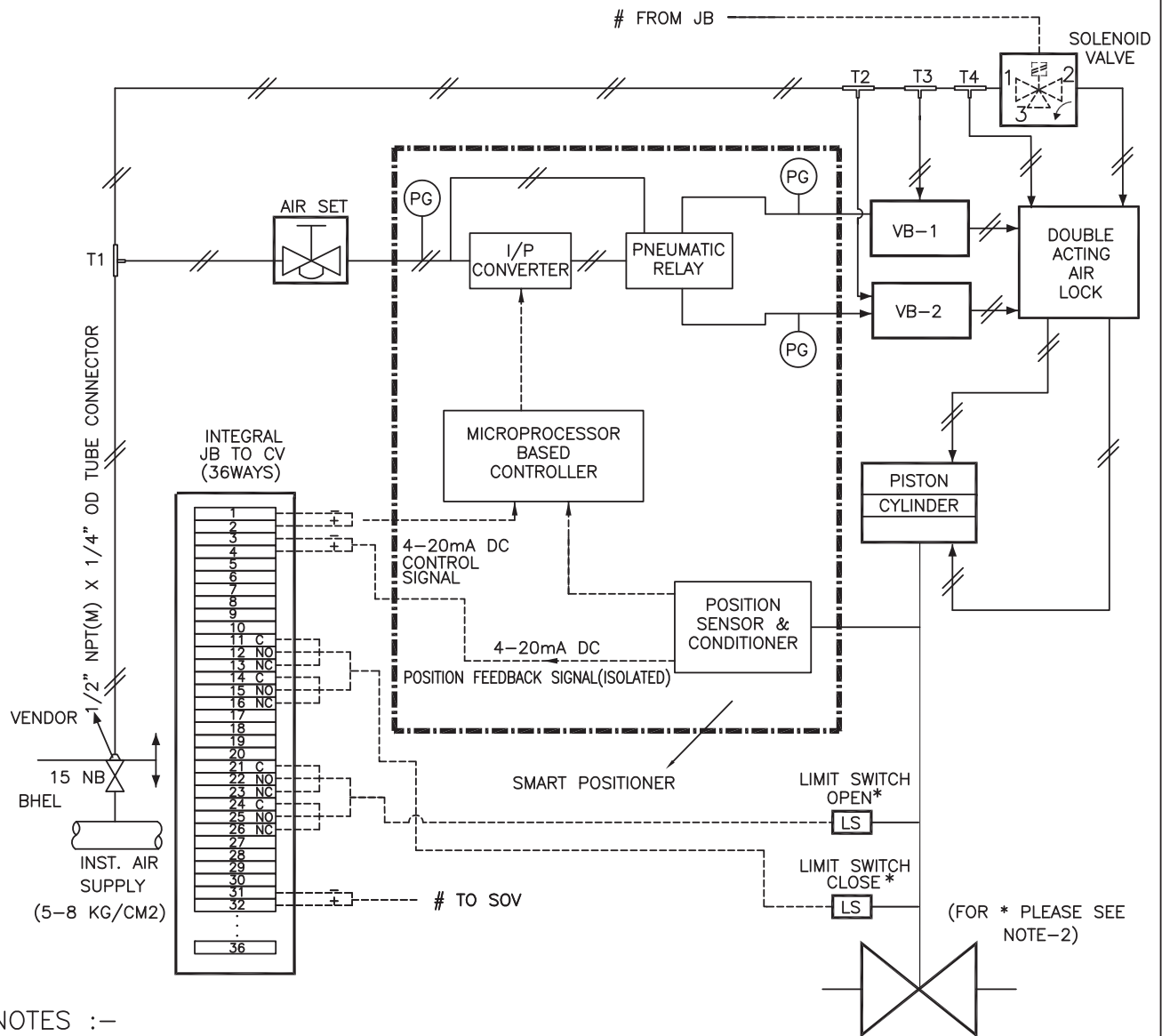

NOTES :-

1. POSITION OF EACH VALVE ON SUPPLY AIR FAILURE / ELECTRICAL SIGNAL FAILURE SHALL BE AS PER SPECIFICATION / DATA SHEET.
2. SOLENOID VALVE WILL BE PROVIDED ONLY FOR CONTROL VALVES IF INDICATED IN RESPECTIVE DATA SHEETS.
3. SOLENOID VALVES PORTS CONDITION:
PORT 1 AND 2 SHALL BE CONNECTED UNDER DE-ENERGISED CONDITION.
PORT 2 AND 3 SHALL BE CONNECTED UNDER ENERGISED CONDITION.
4. PRESSURE GAUGES REQUIRED FOR AIR SUPPLY & OUTPUT(S).
5. MOUNTING ACCESSORIES AS REQUIRED.
6. POSITION FEEDBACK SIGNAL SHALL BE 2 WIRE 4-20mA ISOLATED SIGNAL.
7. JB TERMINALS SHALL BE CAGE CLAMP TYPE SUITABLE FOR 2.5 SQ. MM COPPER WIRE. EXTERNAL CONNECTION, THROUGH CABLE GLAND, SHALL BE AS PER DATA SHEET
8. ALL APPLICABLE ACCESSORIES SHALL BE PROVIDED AS INDICATED IN THE INDIVIDUAL CONTROL VALVE DATA SHEET / ACCESSORIES DATA SHEET.
9. 12 METERS 1/4" SS TUBING (AS PER ACCESSORIES DATA SHEET) & 1 SET OF SS FITTINGS TO BE SUPPLIED FOR EACH CONTROL VALVE FOR CONNECTION TO ISO VLV AT INST AIR HEADER ON ONE END AND TO AIR LOCK RELAY/AIR FILTER REGULATOR ON THE OTHER END. ALL THE SS FITTINGS SHALL BE DOUBLE COMPRESSION TYPE.
10. VOLUME BOOSTER (ALONG WITH TEE-T2 AND RELATED TUBING & CONNECTORS) SHALL BE PROVIDED IF REQUIRED. AIR CONNECTION TO VOLUME BOOSTER FROM TEE-T2 SHALL BE PROVIDED.



SPECIFICATION NO.: PE-TS-XXX-145-I104

DRG. No.

PES-145-06B

TITLE:-

CONTROL VALVE HOOK-UP DIAGRAM

ISSUE NO. 2
REV. 00

DATE 25.05.16

SHEET

43 OF 51

CONTROL VALVE HOOK-UP DIAGRAM (FOR ON / OFF TYPE)

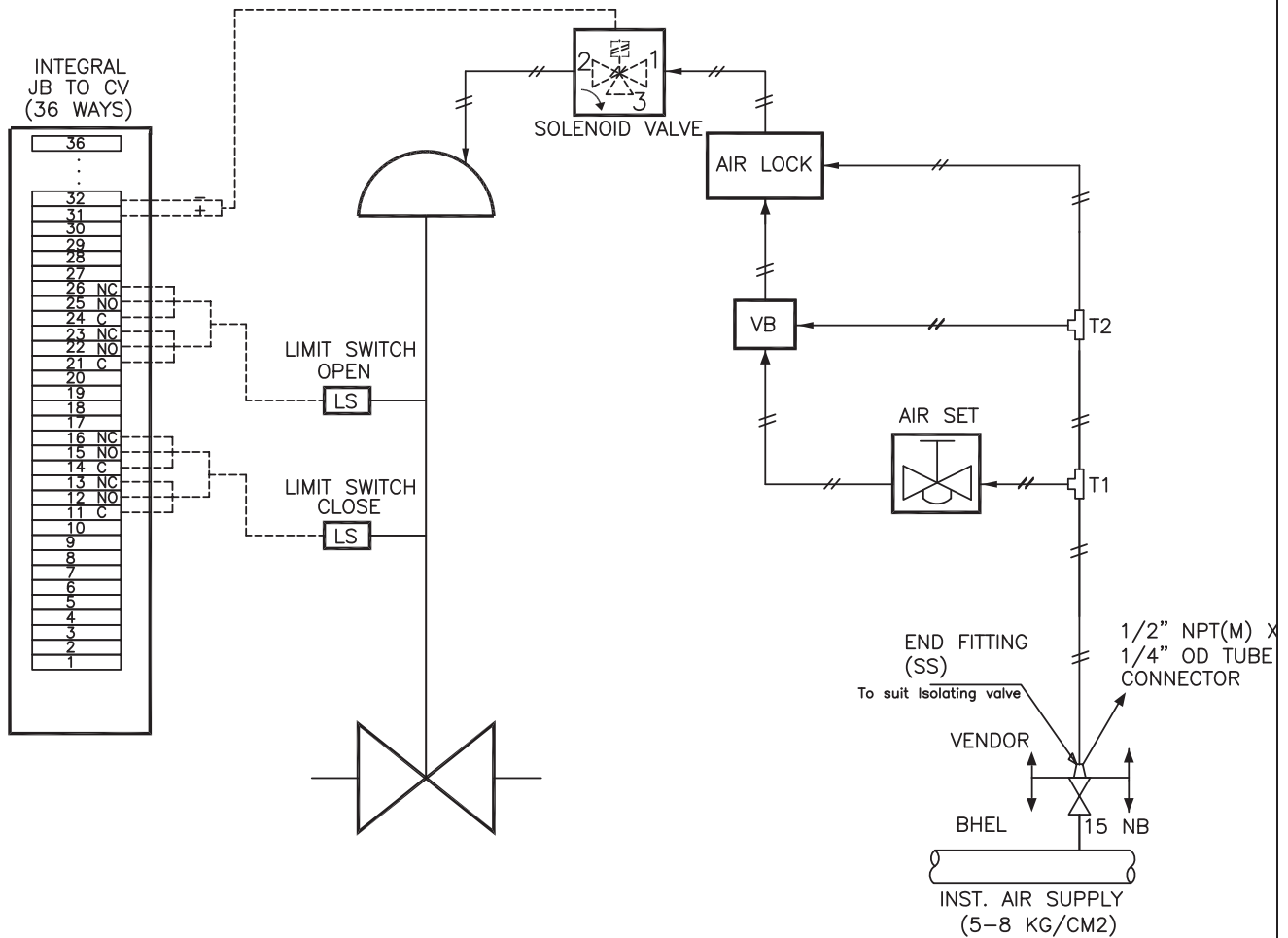

NOTES :-

1. POSITION OF EACH VALVE ON SUPPLY AIR FAILURE / ELECTRIC SIGNAL FAILURE SHALL BE AS PER SPECIFICATION / DATA SHEET.
2. SOLENOID VALVES PORTS CONDITION:
PORT 1 AND 2 SHALL BE CONNECTED UNDER DE-ENERGISED CONDITION.
PORT 2 AND 3 SHALL BE CONNECTED UNDER ENERGISED CONDITION.
3. MOUNTING ACCESSORIES AS REQUIRED.
4. JB TERMINALS SHALL BE CAGE CLAMP TYPE SUITABLE FOR 2.5 SQ. MM COPPER WIRE. EXTERNAL CONNECTION, THROUGH CABLE GLAND, SHALL BE AS PER DATA SHEET.
5. ALL APPLICABLE ACCESSORIES SHALL BE PROVIDED AS INDICATED IN THE INDIVIDUAL CONTROL VALVE DATA SHEET / ACCESSORIES DATA SHEET.
6. 12 METERS 1/4" SS TUBING (AS PER ACCESSORIES DATA SHEET) & 1 SET OF SS FITTINGS TO BE SUPPLIED FOR EACH CONTROL VALVE FOR CONNECTION TO ISO VLV AT INST AIR HEADER ON ONE END AND TO AIR LOCK RELAY/AIR FILTER REGULATOR ON THE OTHER END. ALL THE SS FITTINGS SHALL BE DOUBLE COMPRESSION TYPE.



1 X 660 MW BHUSAWAL STPP

TITLE:-

CONTROL VALVE HOOK-UP DIAGRAM

**DRG.
No.**

PE-TS-415-145-I104

**REV.
No.**

02

DATE

08.03.19

SHEET

49

OF

51



Technical specification for
Control Valves with Accessories
(Pneumatically Operated)

SPECIFICATION NO. **PE-TS-415-145-1801**

DOCUMENT NO.

VOLUME **II-B**

SECTION **D**

ISSUE NO. 2

REV. NO. 00

DATE: 10.01.2020

SECTION – D

GUIDELINES FOR PACKING (PES-145-06C)



Technical specification for
Control Valves with Accessories
(Pneumatically Operated)

SPEC NO.: PE-TS-415-145-I108

DOCUMENT NO.: PES-145-06C

VOLUME II B

SECTION D

ISSUE NO. 2, REV. 00

DATE 10.01.2020

Guidelines for Packing

- ✓ After inspection of control valves assembly. Smart Positioner along with Pressure Gauge shall be disassembled & packed separately.
- ✓ Threaded connection of Smart Positioner & Pressure Gauge shall be shipped with the end caps fitted to avoid any damage.
- ✓ Instructions with sketch for mounting the Smart Positioner & Pressure Gauge shall be sent along with the aforesaid accessories.
- ✓ Packing of the control valves and Smart Positioner along with Pressure Gauge shall be done in separate wooden boxes/cases in order to avoid damage during transit and also during storage at site in tropical climatic conditions for a period of 18-24 months.
- ✓ All valves & smart positioner along with pressure gauges shall be packed properly with quality wooden planks with proper wooden frame support. Moreover the valves are internally covered with polythene sheets to protect from the water and moisture entry.
- ✓ Stronger shock absorbing cover material like expanded Polyurethane which can take any direct impact on it shall be used for packing
- ✓ Proper reaper support to be provided in the packing and Valve assembly to be aligned properly to avoid the damage of accessories during transit due to vibration effect.
- ✓ Marking for Fragile & Condensing environment shall be done on the packing box.



The Following Details are to be marked on the Packing Cases

- ✓ Address of consignee
- ✓ Purchase order no.
- ✓ Description of items or title of packing list
- ✓ Weight
- ✓ Dimension of the Box
- ✓ Marking showing upright position
- ✓ Marking showing sling position
- ✓ Marking showing umbrella
(i.e. for machines/components to be stored under covered storage)



Technical specification for
Control Valves with Accessories
(Pneumatically Operated)

SPECIFICATION NO. **PE-TS-415-145-1801**

DOCUMENT NO.

VOLUME **II-B**SECTION **D**

ISSUE NO. 2

REV. NO. 00

DATE : 10.01.2020

SECTION-D

SUB-VENDOR LIST

 MAHAGENCO <small>Maharashtra State Power Generation Co. Ltd.</small>	MAHARASHTRA STATE POWER GENERATION CO. LTD.	Volume: II
	BID SPECIFICATION NO.: DG/BSL U-6/2011/T-1	Section – 11
REV: R0	MASTER SPECIFICATIONS	Page 528 of 555

<u>SR. NO.</u>	<u>NAME OF EQUIPMENT / ITEM</u>	<u>APPROVED VENDORS</u>
		(f) ENDRESS & HAUSER
		(g) FORBES MARSHALL
1.14	GAUGES (PRESSURE, DIFF. PRESSURE)	(a) A N INSTRUMENTS PVT. LTD., KOLKATA
		(b) GENERAL INSTRUMENTS CONSORTIUM, GOA/ MUMBAI
		(c) GOA THERMOSTATIC INSTRUMENTS, GOA
		(d) FORBES MARSHALL LTD., HYDERABAD
		(e) WAAREE INDUSTRIES, MUMBAI
		(f) H.GURU INSTRUMENTS (SOUTH INDIA), BANGALORE
		(g) WIKA INSTRUMENTS INDIA PVT. LTD., PUNE
		(h) GOA INSTRUMENTS PVT. LTD.,
		(i) MONOMETER, MUMBAI
		(j) BELLS CONTROLS LTD., KOLKATA
		(k) SWITZER INSTRUMENTS LTD., CHENNAI
		(l) WIKA ALEXANDER WIEGAND GMBH&CO., GERMANY
		(m) BUDENBURG GUAGE CO. LTD
		(n) INSTRUMENTATION PVT. LTD., BANGALORE
		(o) INDOSONIC INSTRUMENT, MUMBAI
		(p) PRECISION
		(q) ASHCROFT

CONSULTANT : PROCON ENGINEERS

 MAHAGENCO Maharashtra State Power Generation Co. Ltd.	MAHARASHTRA STATE POWER GENERATION CO. LTD.	Volume: II
	BID SPECIFICATION NO.: DG/BSL U-6/2011/T-1	Section – 11
REV: R0	MASTER SPECIFICATIONS	Page 530 of 555

<u>SR. NO.</u>	<u>NAME OF EQUIPMENT / ITEM</u>	<u>APPROVED VENDORS</u>
		(g) DELTA CONTROLS LTD., U.K.
		(h) KDG INSTRUMENTS LTD. U.K.
		(i) ASHCROFT
		(j) DWAYER, USA
		(k) GENERAL INSTRUMENTS CONSORTIUM
1.17	TEMPERATURE SWITCH	(a) INDOSS INDUSTRIES LTD., GHAZIABAD
		(b) SWITZER INSTRUMENTS COMPANY, CHENNAI
		(c) GENERAL INSTRUMENTS CONSORTIUM, MUMBAI
		(d) SOR INC., USA
		(e) PYROELECTRIC, GOA DRESSER INDUSTRIES INC, USA
		(f) REGULATEURS GEORGIN, FRANCE
		(g) DELTA CONTROLS LTD., U.K.
		(h) KDG INSTRUMENTS LTD. U.K.
1.18	AIR FILTER REGULATOR	(a) PLACKA, CHENNAI
		(b) SHAVO NORGREN, INDIA
1.19	MASS FLOW METER (CORROLIOUS PRINCIPLE)	(a) EMERSON PROCESS MANAGEMENT (I) LTD
		(b) ABB
		(c) YOKOGAWA
		(d) ENDRESS+ HAUESER
		(e) GE SENSING & INSPECTION TECHNOLOGIES
		(f) FORBES MARSHALL

CONSULTANT : PROCON ENGINEERS

<u>SR. NO.</u>	<u>NAME OF EQUIPMENT / ITEM</u>		<u>APPROVED VENDORS</u>
1.20	I/P CONVERTER	(a)	ECKHARDT, GERMANY
		(b)	MTL, CHENNAI
		(c)	ABB
		(d)	WATSON SMITH (PRESENTLY NORGREN)
		(e)	EMERSON PROCESS MGMT ASIA PACIFIC LTD.
		(f)	MOORE CONTROLS
1.21	FLOW ELEMENTS	(a)	INSTRUMENTATION LTD.
		(b)	MICRO PRECISION PRODUCTS
		(c)	ENGINEERING SPECIALITIES PVT. LTD.
		(d)	GENERAL INSTRUMENTS
1.22	LEVEL GAUGES (FLOAT TYPE)	(a)	SB ELECTRO
		(b)	SIGMA
		(c)	V AUTOMAT
		(d)	LEVCON
		(e)	CHEMTROLS
		(f)	ASIAN INDUSTRIAL VALVES
1.23	ORP TRANSMITTERS	(a)	FORBES MARSHALL
1.24	DENSITY METER (NUCLEONIC TYPE)	(a)	ENDRESS + HAUSER
		(b)	THERMO MEASURE TECH.
		(c)	CHEMTROL (THERMO FISHER)
1.25	DENSITY METER (NON-NUCLEONIC TYPE)	(a)	ENDRESS + HAUSER
		(b)	THERMO MEASURE TECH.
		(c)	CHEMTROL (THERMO FISHER)

CONSULTANT : PROCON ENGINEERS

 MAHAGENCO <small>Maharashtra State Power Generation Co. Ltd.</small>	MAHARASHTRA STATE POWER GENERATION CO. LTD.	Volume: II
	BID SPECIFICATION NO.: DG/BSL U-6/2011/T-1	Section – 11
REV: R0	MASTER SPECIFICATIONS	Page 534 of 555

<u>SR. NO.</u>	<u>NAME OF EQUIPMENT / ITEM</u>		<u>APPROVED VENDORS</u>
		(d)	SYNELEC
		(e)	DELTA, THAILAND / DELTA POWER SYSTEMS, INDIA
2.10	HART COMMUNICATOR	(a)	HONEYWELL, USA/PUNE
		(b)	EMERSON PROCESS (FORMERLY FISHER ROSEMOUNT), USA / DAMAN
		(c)	YOKOGAWA, JAPAN / YOKOGAWA, INDIA
		(d)	MERIAM, USA / CHEMTROLS, MUMBAI
		(e)	ABB, GERMANY / INDIA
		(f)	FUJI, JAPAN
2.11	HART MANAGEMENT SYSTEM	(a)	PEPPERL+FUCKS, GERMANY / INDIA
		(b)	MTL, UK / INDIA
		(c)	EMERSON PROCESS, USA / DAMAN
2.12	ALARM ANNUNCIATION SYSTEM	(a)	PROCON, CHENNAI
		(b)	I I C, HYDERABAD
		(c)	MINILEC, PUNE
		(d)	IIC, MUMBAI
		(e)	PIRIE, MUMBAI
		(f)	PECON, VADODARA
		(g)	POSITRONICS
2.13	RMCMS (ROTATING MACHINE CONDITION MONITORING SYSTEM)	(a)	VIBROTECH (M/S MEGITT INDIA PVT. LTD.)
		(b)	M/S SKF INDIA LTD.
2.14	ACOUSTIC PYROMETER	(a)	BONNENBERG + DRESCHER GMBH, GERMANY

CONSULTANT : PROCON ENGINEERS

<u>SR. NO.</u>	<u>NAME OF EQUIPMENT / ITEM</u>		<u>APPROVED VENDORS</u>
		(d)	EMERSON
		(e)	ABB
		(f)	FUJI (AIC)
5.6	NOX / SO2 ANALYSER (IN SITU)	(a)	CODEL, UK
		(b)	FORBES MARSHALL
		(c)	LAND COMBUSTION, UK
5.7	OZONE ANALYSER	(a)	BMT MESSTECHNIK, GMBH
5.8	RESIDUAL OZONE ANALYSER	(a)	ECO SENSORS / KAUFFMANN UMWITTECHNIK .EK
5.9	OZONE LEAK DETECTOR	(a)	OTPL
6.0	<u>CONTROL VALVES / ACTUATORS / SOLENOID VALVES:</u>		
6.1	ELECTRICAL ACTUATORS FOR REGULATING & OPEN / CLOSE VALVES	(a)	ROTORK CONTROL (INDIA) LTD.,
		(b)	AUMA (INDIA) LTD.,
		(c)	LIMITORQUE INDIA LTD.
6.2	PNEUMATIC ACTUATORS-REGULATING & OPEN / CLOSE	(d)	INSTRUMENTATION LTD., PALGHAT
		(e)	KELTRON CONTROLS, KERALA
6.3	SH/RH SPRAY CONTROL VALVES	(a)	MIL CONTROLS LTD.
	SH/RH SPRAY BLOCK VALVES	(b)	INSTRUMENTATION LTD. PALGHAT
	FEED CONTROL VALVES	(c)	FISHER SANMAR LTD.
		(d)	CONTROL COMPONENT INC., USA
		(e)	HORA (HOLTER-REGELARMATUREN GMBH & CO.)
6.4	LFO/HFO CONTROL, AND TRIP VALVES, FLOW CONTROL, PRESSURE	(a)	MIL CONTROLS LTD.
		(b)	INSTRUMENTATION LTD. PALGHAT

CONSULTANT : PROCON ENGINEERS

 MAHAGENCO Maharashtra State Power Generation Co. Ltd.	MAHARASHTRA STATE POWER GENERATION CO. LTD.	Volume: II
	BID SPECIFICATION NO.: DG/BSL U-6/2011/T-1	Section – 11
REV: R0	MASTER SPECIFICATIONS	Page 541 of 555

<u>SR. NO.</u>	<u>NAME OF EQUIPMENT / ITEM</u>		<u>APPROVED VENDORS</u>
	CONTROL, TEMP. CONTROL, AND BURNER TRIP VALVES, BALL VALVES	(c)	FOURESS ENGG (I) LTD, BANGALORE
		(d)	SAMSON CONTROLS , PUNE
6.5	SOOT BLOWER PRESSURE REDUCING VALVE	(a)	MIL CONTROLS LTD.
		(b)	INSTRUMENTATION LTD., PALGHAT
		(c)	FISHER SANMAR LTD.
		(d)	CONTROL COMPONENT INC., USA
		(e)	HORA (HOLTER REGELARMATUREN GMBH & CO.)
6.6	APRDS CONTROL VALVES	(a)	INSTRUMENTATION LTD.
		(b)	CONTROL COMPONENT INC., USA
		(c)	HORA (HOLTER REGELARMATUREN GMBH & CO.)
6.7	CONTROL VALVES- NON CRITICAL	(a)	DEZURIK COPES VULCAN LTD., U.K.
		(b)	CONTROL COMPONENT INC., USA
		(c)	FISHER SANMAR LIMITED
		(d)	INSTRUMENTATION LTD
		(e)	MIL CONTROL LTD.
		(f)	FISHER XOMOS SANMAR LTD.
		(g)	HORA (HOLTER REGELARMATUREN GMBH & CO.)
6.8	SOLENOID VALVE	(a)	ASCO, CHENNAI
		(b)	ROTEX AUTOMATION LTD., GUJRAT
		(c)	AVCON CONTROLS, MUMBAI
6.9	HP/LP BYPASS VALVES	(a)	BOPP & REUTHER SR GMBH CONTROL COMPONENTS INC (CCI)

CONSULTANT : PROCON ENGINEERS

 MAHAGENCO <small>Maharashtra State Power Generation Co. Ltd.</small>	MAHARASHTRA STATE POWER GENERATION CO. LTD.	Volume: II
	BID SPECIFICATION NO.: DG/BSL U-6/2011/T-1	Section – 11
REV: R0	MASTER SPECIFICATIONS	Page 544 of 555

<u>SR. NO.</u>	<u>NAME OF EQUIPMENT / ITEM</u>		<u>APPROVED VENDORS</u>
		(g)	TOUVAY AND CAUVIN GULF EC, DUBAI
		(h)	JINDAL SAW PIPES LTD., INDIA
		(i)	SUMITOMO CORPORATION, JAPAN / KAWASAKI
		(j)	RATNAMANI METALS & TUBES LTD., AHMEDABAD
7.7	JUNCTION BOX (FRP)	(a)	DEVI POLYMERS, CHENNAI
		(b)	SUCHITRA INDUSTRIES, BANGALORE
		(c)	RITTAL
		(d)	PYROTECH
		(e)	L&T
		(f)	HENSEL ELECTRIC INDIA PVT. LTD., SRIPERUMBUDUR
7.8	AIR CYLINDER	(a)	VELJAN HYDRAIR, HYDERABAD
		(b)	NUCON INDUSTRIES, HYDERABAD
		(c)	PRECISION ENGG. (PREAC), BANAGALORE
		(d)	ASCO, CHENNAI
8.0	<u>CABLES:</u>		
8.1	CONTROL CABLES	(a)	DELTON CABLES, FARIDABAD
		(b)	UNIVERSAL CABLES, SATNA
		(c)	NICCO CABLE, KOLKATA
		(d)	POLYCAB, DAMAN
		(e)	GAYOLENE, MUMBAI
		(f)	RELIANCE ENGRS, BANGALORE
		(g)	CORDS CABLES, RAJASTHAN

CONSULTANT : PROCON ENGINEERS

 MAHAGENCO <small>Maharashtra State Power Generation Co. Ltd.</small>	MAHARASHTRA STATE POWER GENERATION CO. LTD.	Volume: II
	BID SPECIFICATION NO.: DG/BSL U-6/2011/T-1	Section – 11
REV: R0	MASTER SPECIFICATIONS	Page 547 of 555

<u>SR. NO.</u>	<u>NAME OF EQUIPMENT / ITEM</u>		<u>APPROVED VENDORS</u>
	WITH DCDB	(b)	AMARARAJA, TIRUPATI
		(c)	CHHABI ELECTRICALS, JALGAON
		(d)	HBL POWER SYSTEMS, HYDERABAD
		(e)	MASS TECH CONTROLS
9.3	BATTERY (TUBULAR/PLANTE) (TUBULAR) (TUBULAR)	(a)	EXIDE, KOLKATA
		(b)	HBL NIFE, HYDERABAD UNION BATTERY (BUI PUNE)
9.4	BATTERY (NICKEL- CADMIUM)	(a)	HBL POWER SYSTEMS, HYDERABAD
		(b)	AMCO, BANGALORE

Laboratory Instruments:

Bidder shall submit the vendor list with credentials for Mahagenco's approval.

NOTE : The vendors indicated in the above list are Mahagenco's approved vendors, however, the product of above vendors proposed for this project shall meet the requirements stipulated in 'Proven Product' Cl. No. 5.0 of Vol. V, Section I of Tender Specification.

CONSULTANT : PROCON ENGINEERS

 MAHAGENCO <small>Maharashtra State Power Generation Co. Ltd.</small>	MAHARASHTRA STATE POWER GENERATION CO. LTD.	Volume: V
	BID SPECIFICATION NO.:DG/BSL U-6/2011/T-1	Section – 1
REV: R0	CONTROL & INSTRUMENTATION	Page 37 of 718

The required quantities of cable accessories shall be similarly estimated on the basis of number of terminations and proposed routing of the cables and shall be included in the offer allowing a positive allowance of at least 30% for each accessory. The exact quantity of different accessories shall be specified in the offer. Any shortfall in the quantity of accessories observed during actual laying shall be compensated at no extra cost.

5.0 PROVEN PRODUCT

5.1 The offered model of DCS, Microprocessor based control system must have been successfully supplied, erected, tested and commissioned as complete station Control & Instrumentation system for at least two units of capacity not less than 600 MW supercritical Thermal Power Station(s) with reheat type pulverized coal fired boiler. Further, these units should be in successful operation for a minimum period of two (2) years.

5.2 Similarly, all other C&I equipment/PLC/systems/sub-systems/instruments and accessories in the power cycle shall also be of make and model whose guaranteed and trouble-free performance has been proven at least for two (2) years in not less than two (2) different reheat type pulverized coal fired units of unit size not less than 500 MW.

5.3 Bidder shall furnish required information to fully satisfy Owner regarding successful operation and high reliability of products/systems furnished.

6.0 CODES AND STANDARDS

6.1 Items such as thermowells, control valves, flow elements and other in line devices in high and medium pressure steam, feed water and similar services, which fall under the purview of Indian Boiler Regulation Act shall be either certified by IBR or shall be certified by authorities acceptable to IBR. It shall be responsibility of Bidder to obtain the necessary approval of the concerned Authority/Chief Inspector of Boiler for the design and design calculations, manufacturing and erection procedure as called for under the IBR Act for all items requiring such certification.

6.2 Generally, the following latest edition of codes and standards prevailing at the time of award of contract shall be applicable.