



**PREQUALIFICATION CRITERIA FOR  
TRAIN SET (SLEEPER) 80 SETS PROJECT**

PQC/ PES-TE/BOI-80  
trainsets

Revision No. 00

Page 01 of 01

COPYRIGHT AND CONFIDENTIAL  
 The information on this document is the property of BHARAT HEAVY ELECTRICALS LIMITED.  
 It must not be used directly or indirectly in anyway detrimental to the interest of the company.

**1.0 Pre-Qualification Criteria**

1.1 The bidder should be a manufacturer/supplier of the product for Rolling stock application of Railways for 3 phase IGBT based Train sets/RRTS/Semi high speed trains/AC EMU/MEMU/Metros in India or any railway systems in the world.

1.2 For supplies made in India, bidder should be approved vendor of Indian Railways /Metro/RRTS.

**OR**

For supplies made to any railway systems in the world, bidder shall provide approval, authenticated by country's recognized railway organization. Acceptance of such approvals will be at BHEL's discretion.

1.3 The product should have valid type test certificates complying to relevant latest IEC and other standards mentioned in the Reference Technical Specification for rolling stock application on the date of submission of the tender. The bidder shall fully comply with the type and routine test & inspection clause of the technical specification. The bidder shall conduct/repeat type tests either partially or fully **for the offered product** without any price implication to BHEL. Decision to conduct type test shall be at BHEL's discretion.

**OR**

The bidder shall provide valid type test certificate/reports complying to relevant latest IEC and other standards for similar product supplied as per clause 1.1. Acceptance of such type test certificate/reports will be at BHEL's discretion. In such case, bidder will be considered for technical evaluation. The bidder shall conduct type tests fully **for the offered product**, without any price implication to BHEL.

1.4 Those bidder(s) who are registered with BHEL/ BHEL's customer (as the case may be) shall be considered for technical evaluation, subject to meeting above PQC clauses.

Bidders who are not registered with BHEL/BHEL's customer (as the case may be) can also quote in the tender. However, their credentials will be assessed for consideration in the tender, before price bid opening, subject to meeting above PQC clauses.

**2.0 Documents to be submitted**

All the relevant documents proof for points referred in 1.0 shall be submitted along with the tender.

**Rev. 00**

**Approved:** Anjul

**Prepared**

Narasimha Shenoy

**Checked**

S C Hansdah

**Date:**

16.02.2024

**Bharat Heavy Electricals Limited Electronics Division, Mysore Road, Bengaluru**

**Purchase Specification no - PS4452988**

**Item - Passenger Alarm System Handle**

**Vendor name - M/s**

**Price Format for Vande Bharat Train Sets**

Sl. No.	Material Code	Item Description	Applicability (Yes/No)	Qty [A1]	UOM	Unit Rate [A2]	Cost per Rake [A3=A1*A2]	Total No. of Rakes [A4]	Total Qty for Supply [A1*A4]	Total Cost [A5=A3*A4]	Remarks
1	-	<b>Equipment cost</b>		Per rake		in INR	in INR	in Nos.	Nos. / Set	in INR	
1.1	PR2970000059	Basic Price per Passenger Alarm system [PAS] handle as per clause 2.2.1 of the technical specification	Yes	119	Set		0	10	1,190	0	
1.2	-	Freight & Insurance	Yes	119	Set		0	10	1,190	0	
<b>Total of sl no 1</b>											
2	-	<b>Maintenance &amp; Spares cost</b>									
2.1	-	AOH (1.5 Yrs) Spare Kit with consumables considering 6 years' consumption	No	X	X	X	X	X	X	X	
2.2	-	IOH (3 Yrs) Spare Kit with consumables considering 6 years' consumption	No	X	X	X	X	X	X	X	
2.3	-	POH (6 Yrs) Spare Kit with consumables considering 6 years' consumption	No	X	X	X	X	X	X	X	
2.4	-	Special Tool Kit (One time)	No	X	X	X	X	X	X	X	
2.5	-	AMC for 4 (four) years post warranty period	No	X	X	X	X	X	X	X	
2.6	-	Spares for annual maintenance (for one year)	No	X	X	X	X	X	X	X	
<b>Total of sl no 2</b>											
3	-	<b>Commissioning &amp; Supervision of Erection</b>									
3.1	-	Commissioning & Supervision of Erection of Prototype Rake	Yes	1	rake		0	2	2	0	
3.2	-	Commissioning & Supervision of Erection of All Rakes (Including Prototype)	No	X	X	X	X	X	X	X	
<b>Total of sl no 3</b>											

**Note -**

1. Any item required for functional integrity and commissioning of the item/system and not considered above shall be provided by the bidder without any cost implication to BHEL.

2. Bidder shall quote as per the quantities mentioned in this table only. Quantities mentioned in the specification are for reference purpose.

3. Tender evaluation shall be done on the total of sl. no. 1, 2 & 3. Purchase Order for Items in sl. no. 2 may be placed separately.

4. Each rake consists of 16 coaches.



**BHARAT HEAVY ELECTRICALS LIMITED**  
**ELECTRONICS DIVISION**  
**Mysore Road, Bangalore**

**Doc. No : PS4452988**

**Rev. No : 00**

**Page : 1 of 3**

**CUSTOMER/  
USER**

BHEL/INDIAN RAILWAYS

**PROJECT**

MANUFACTURING CUM MAINTENANCE OF VANDE  
BHARAT TRAINSETS

**COPYRIGHT AND CONFIDENTIALITY**  
 The information on this document is the property of  
**BHARAT HEAVY ELECTRICALS LTD.**  
 It must not be used directly or indirectly in anyway detrimental to the  
 interest of the company

# Purchase Specification for Passenger Alarm system [PAS] handle

**Rev  
No.**

**Date**

**Altered**

**Checked**

**Approved**

**Revision Details**

Issued by:  
Traction Engg. Dept.,  
BHEL-EDN

Approved

Anjul

Prepared

N. N Shenoy  
Narasimha Shenoy

Checked

S C Hansdah

Date

24.03.2024



Purchase Specification for  
Passenger Alarm system Handle

Project – Vande  
Bharat – 80 sets

Doc. No.: **PS4452988**

Rev. No. 00

### 1.1 Technical Specification

1.1.1 For the technical requirement, bidder to refer to **PS4452988** - Part A

1.1.2 This specification is for the procurement of the PAS handle assembly. The technical requirement for the handle assembly is specified in clause 2.2.1 of the technical specification. Scope of supply shall include the handle assembly & associated mounting arrangement.

1.1.3 Specification of other items comprising the Passenger Alarm system as described under section 2.2 of the technical specification is mentioned for reference only & is not under the scope of supply unless explicitly mentioned.

### 2.1 Bill of Quantities

2.1.1 Bill of Materials in the technical specification (Part A) is for information only. Bidder to consider & quote for the items as per the quantity mentioned in the RFQ

### 3.1 Packing Instructions

3.1.1 Successful bidder to mandatorily follow the packing instructions given in Part A

3.1.2 Stack-ability of the packaged boxes & storage worthiness/durability to be ensured

3.1.3 Successful bidder shall ensure that set-wise Packing List be pasted on each Box (Typical format enclosed with this document)



Purchase Specification for  
Passenger Alarm system Handle

Project – Vande  
Bharat – 80 sets

Doc. No.: **PS4452988**

Rev. No. 00

**Set wise Packing List to be pasted on each Box**

Supplier shall furnish the packing list as per the format given below:

BHEL PO No.	
BHEL Material Code	
Material Description	
Quantity (Set)	
Box No (per set)	

**Bill of Materials** (Supplier shall list down all the items including loose items and respective quantities):

Main Item:

Sl. No.	Item description	Quantity per Set	Total Sets packed in the Box (applicable in case of multiple sets in one Box)

Loose Items (if any):

Sl. No.	Item description	Quantity per Set	Total Sets packed in the Box (applicable in case of multiple sets in one Box)

Supplier details:

**Notes for suppliers:**

- 1) Suppliers shall pack items, set wise in one box. In case of multiple boxes for one set, supplier shall identify box numbers (Set 1/ Box1, Set 1/ Box2 etc.)
- 2) Packing list shall be pasted on each box, as per actual contents inside the box. This list will be in addition to the supplier's standard packing list.
- 3) Box wise Packing list shall be shared with BHEL MM and same will be mandatory for dispatch clearance.



**BHARAT HEAVY ELECTRICALS LIMITED**

**Electronics Division**

Mysore Road, Bangalore

Doc. No.:

PS4452988 - Part A

Rev. No.: 00

PAGE: 1 of 32

**COPYRIGHT AND CONFIDENTIALITY**  
The information on this document is the property of BHARAT HEAVY ELECTRICALS LTD.  
It must not be used directly or indirectly in anyway detrimental to the interest of the company

# TECHNICAL SPECIFICATION

## Passenger Alarm System (PAS)

**Approved by**

Anjul

**Prepared by**

Narasimha Shenoy

**Checked by**

Suresh Hansdah

**Date**

24.03.2024

Issued by:  
Traction Engg. Dept.,  
BHEL-EDN



# Technical Specification for Passenger Alarm system

Doc. No.: PS4452988 - Part A, Rev. 00

**PROJECT**  
Vande Bharat 80  
rakes

## Table of Contents

<b>Section 1</b> .....	<b>4</b>
<b>Scope, Quantities &amp; Eligibility</b> .....	<b>4</b>
1.1 Scope .....	4
1.2 Bill of material / Scope of supply .....	4
1.3 Eligibility Criteria .....	4
1.4 Clause by clause compliance .....	4
1.5 Reference Specifications .....	4
<b>Section 2</b> .....	<b>5</b>
<b>Technical Specification</b> .....	<b>5</b>
2.1 Introduction .....	5
2.2 Detailed Requirement .....	5
2.3 Equipment Testing .....	5
2.4 Erection and Commissioning .....	6
2.5 Documents to be provided by supplier .....	6
2.6 Applicable Standards .....	7
<b>Section 3</b> .....	<b>8</b>
<b>Project Details And General Specifications</b> .....	<b>8</b>
3.1 General .....	8
3.2 Instruction to Bidders .....	8
3.3 General Design Requirements .....	8
3.4 Train Formation .....	10
3.5 Ingress Protection .....	10
3.6 Ambient Conditions / Operating Conditions .....	10
3.7 Standards .....	12
3.8 Engineering Data .....	12
3.9 Marking of Equipment & Rating Plate .....	14
3.10 Infringement of Patent Rights .....	14
3.11 Document Submissions .....	14
3.12 Quality Assurance Programme .....	15
3.13 Type and Routine Testing & Inspection .....	15
3.14 Materials and Workmanship .....	17
3.15 Packing and Storage .....	17
3.16 Fire Prevention .....	18
3.17 Maintenance Manual, Spare Parts Catalogue & Material Specification .....	18
<b>Section 4</b> .....	<b>19</b>
<b>Reliability, Availability, Maintainability And Safety (RAMS)</b> .....	<b>19</b>
4.1 Key Performance Indicators .....	19
4.2 Reliability Availability Maintainability and Safety (RAMS) .....	19
4.3 RAMS Documentation .....	20
4.4 Service Life of Equipment/System .....	20
4.5 Train Maintenance Schedule (Tentative) .....	22
<b>Section 5</b> .....	<b>23</b>

	<b>Technical Specification for Passenger Alarm system</b>	<b>PROJECT</b> Vande Bharat 80 rakes
	Doc. No.: PS4452988 - Part A, Rev. 00	

<b>Spares and Consumables for Maintenance .....</b>	<b>23</b>
5.1 Spares and Consumables.....	23
5.2 Scheduled Maintenance .....	23
5.3 Unscheduled Maintenance .....	24
5.4 Epidemic Defect Warranty.....	24
5.5 Operation and Maintenance Manual .....	24
5.6 Obsolescence Management.....	25
5.7 Training on Maintenance Aspects.....	25
<b>Revision History .....</b>	<b>30</b>
<b>Performa for Performance Certificate.....</b>	<b>31</b>
<b>Performa for Performance Statement .....</b>	<b>32</b>

	<b>Technical Specification for Passenger Alarm system</b>	<b>PROJECT</b> Vande Bharat 80 rakes
	Doc. No.: PS4452988 - Part A, Rev. 00	

## Section 1

### Scope, Quantities & Eligibility

#### 1.1 Scope

This technical specification covers the requirements of design, manufacture, testing at works, packing and dispatch of subject item of this specification.

The equipment is required for the following project –

<b>Name of the customer:</b>	BHEL/Indian railways
<b>Name of the project:</b>	Manufacturing cum Maintenance of Vande Bharat Trainsets

The supply of complete documentation for approval of design, relevant drawings and calculations to the satisfaction of purchaser and RDSO and support documentation associated with the operation and maintenance of the equipment supplied.

The supplier shall submit list of equipment and facilities required for maintenance and overhaul of equipment offered.

#### 1.2 Bill of material / Scope of supply –

Sl. No.	Description	Qty (per 16 car rake)	Remarks
1	Passenger Alarm system handle assembly	119 Nos.	Details given in clause 2.2.1
2	LED-based alarm indicator	32 sets	Details given in clause 2.2.5
3	Dual color (Amber/Red) LED lamp indicator	32 sets	Details given in clause 2.2.3
4	Mounting hardware	1 lot	
5	Other Accessories Required for mounting and electrical connections	As reqd.	

#### 1.3 Eligibility Criteria

The Bidder should be a regular supplier of passenger alarm system with handle for Railway projects of Locomotive/ EMU/ MEMU/ Metros/ Trainsets/ Rolling stock/ other Multiple Unit Trains operating in India or abroad.

#### 1.4 Clause by clause compliance

Vendor to submit clause by clause compliance to complete technical specification along with the technical bid.

#### 1.5 Reference Specifications

This purchase specification has the reference of RDSO Specification No. RDSO/PE/SPEC/EMU/0196 (Rev.0)-2019 along with addendums.



## Technical Specification for Passenger Alarm system

Doc. No.: PS4452988 - Part A, Rev. 00

**PROJECT**  
Vande Bharat 80  
rakes

# Section 2 Technical Specification

## 2.1 Introduction

Passenger Emergency Alarm system is provided on the coaches for use by travelling passengers in case of emergency. The coaches shall be equipped with an audio/visual passenger alarm system.

Passenger Alarm system shall comprise the following –

- Passenger alarm device with a handle to be pulled in case of emergency and 2 (two) NO (Normally Open) contacts for integration with the train system. This shall be fitted in each compartment of every coach at an accessible area.
- LED lamp indicator with dual color (Amber/Red) to signify both system healthiness and alarm activation within the entire coach. This shall be installed at the ends of each coach & serve as input to the coach attendants.
- Terminal board to organize the wiring from each handle assembly and interface with the remote I/O cards.
- Flush mounted LED-based Alarm indicator on each side of the coach.

## 2.2 Detailed Requirement

2.2.1 The scope of the Passenger Alarm system shall be in accordance with para 1 of EN 16334.

2.2.2 The Passenger alarm device with a handle shall be manual reset type wherein only the coach attendant may reset the device. A total of 119 Passenger alarm device with handle assembly shall be installed in each rake. An indicative detail is included in annexure-1 with this specification.

2.2.3 The LED lamp indicator with dual color (Amber/Red) shall be operated at 110V DC/AC supply with 3W rating. The terminal connector shall be cage clamp type Wago/Phoenix or equivalent make. An indicative detail is included in annexure-2 with this specification.

2.2.4 The terminal board shall be as per annexure-3 with this specification.

2.2.5 There shall be 2 nos. LED-based alarm indicator on each coach. The indicators shall be as per annexure-4 with this specification.

Summarization of the PAS for a rake is as tabled –

Sl. No.	Description	Qty. per rake	Reference	Remarks
1	PAS handle assembly with 2 nos. NO contacts	119 sets	Railway approved make	IP 54 compliant OR enclosure to ensure IP 54 compliance
2	Terminal board assembly	119 Nos	36680000195, Rev 01	
3	Dual color (Amber/Red) LED lamp indicator	32 sets	Railway approved make	
4	LED-based alarm indicator	32 sets	Railway approved make	

Design and manufacturing of passenger Alarm System with complete assembly shall be in accordance with EN45545. The applicable Hazard level will be HL 3.

## 2.3 Equipment Testing

Valid Type test report is to be submitted for the equipment along with offer, if the equipment is already type tested. In case, ultimate customer insists to repeat the type tests due to any reason, the type test shall be conducted again by the supplier, for which test procedure shall also be submitted by the supplier for approval before conducting the type test. In case ultimate customer desires to

	<b>Technical Specification for Passenger Alarm system</b>	<b>PROJECT</b> Vande Bharat 80 rakes
	Doc. No.: PS4452988 - Part A, Rev. 00	

witness the type tests, the supplier shall have no objection. The supplier is required to quote for the type test charges if any, separately in commercial offer. These charges will be loaded in the equipment price at the time of final evaluation. If Type Test charges are not quoted separately in the commercial offer, then it will be presumed that offer is inclusive of type test charges and no extra payment will be done in case of type test conducted due to any reason.

Supplier to submit Routine test certificates and inspection certificate of equipment as per QAP along with equipment.

Type and routine test will also confirm to relevant clause under section 3 of this technical specification.

## 2.4 Erection and Commissioning

Erection and Installation: Supervision of installation shall be in scope of supplier for prototype/first rake.

Commissioning: Interfacing and commissioning of PAS system shall be in scope of supplier for prototype/first rake.

## 2.5 Documents to be provided by supplier

1	Technical manual of equipment	To be provided along with techno-commercial offer
2	Write-up/ description/ Datasheet of each component	To be provided along with techno-commercial offer
3	Circuit diagram, connection & wiring diagram, equipment drawing with mounting details, weights, center of gravity, etc. and any other relevant drawings	To be provided along with techno-commercial offer
4	Type test reports	To be provided along with techno-commercial offer/after order placement.
5	Type test and Routine test protocol & procedure	To be provided after order placement.
6	Details of proven design	To be provided along with techno-commercial offer
7	Performance statement	To be provided in the attached format along with techno-commercial offer
8	Performance certificate	To be provided in the attached format along with techno-commercial offer
9	Approval letter from RDSO/ Competent authority.	To be provided along with techno-commercial offer
10	Project specific AUTO CAD drawing-2D and 3D model	To be provided after order placement.
11	Project Specific Drawings in A3 size	To be provided after order placement.
12	Technical Manual	To be provided after order placement.
13	Installation, Operational and Maintenance Manual	To be provided after order placement.
14	MTBF/MDBF Values along with the method of calculation	To be provided after order placement.
15	Quality assurance plan (QAP)	To be provided after order placement.

	<b>Technical Specification for Passenger Alarm system</b>	<b>PROJECT</b> Vande Bharat 80 rakes
	Doc. No.: PS4452988 - Part A, Rev. 00	

## 2.6 Applicable Standards

The offered system shall generally conform to the following standards:

1.	IEC 60571	Electronic equipment used on rolling stock
2.	IEC 61373 EN 50155	Shock and Vibration Tests for rolling stock application
3.	IEC 61508 IEC 62279:2015	Railway applications - Communication, signaling and processing systems - Software for railway control and protection systems
4.	EN-45545-2	Fire protection on rail vehicles Part2: Requirements for fire behavior of materials and components.
5.	IEC 61000 EN 50121	Electromagnetic compatibility (EMC)

	<b>Technical Specification for Passenger Alarm system</b>	<b>PROJECT</b> Vande Bharat 80 rakes
	Doc. No.: PS4452988 - Part A, Rev. 00	

## Section 3

# Project Details And General Specifications

### 3.1 General

This section stipulates the General Technical Requirements under the contract and will form an integral part of the Technical Specification.

The provisions under this section are intended to supplement general requirements for the materials, equipment and services covered under other sections and are not exclusive.

However, in case of conflict between the requirements specified in this section and requirements specified under other sections, the requirements specified under respective sections shall hold good.

### 3.2 Instruction to Bidders

The bidders shall submit the technical requirements, data and information as per the technical specification, provided in Section-2.

The bidders shall furnish catalogues, engineering data, technical information, design documents, drawings etc. in English language, fully in conformity with the technical specification.

Whenever required, the bidder shall depute his technical experts to RDSO for design discussions and approval.

### 3.3 General Design Requirements

- i. The stock fitted with the supplied equipment shall meet the operating, service conditions and performance requirements of this specification and shall be suitable for operating conditions on IR.
- ii. All equipment shall be vandal proof and incorporate necessary anti-pilferage features without compromising aesthetics / maintainability.
- iii. Notwithstanding the contents of this specification, the Supplier shall ensure that the equipment supplied by them is complete in all respect so as to achieve the efficient operation & optimum performance of the Train set.
- iv. The equipment design shall incorporate all essential features necessary to yield high traffic use, low maintenance requirements, easy maintainability, high regeneration, high efficiency, light in weight, user & environment friendly and high reliability in train operation. The design shall also facilitate easy erection, inspection, maintenance and replacement of the sub-units/ assemblies of all the equipment.
- v. The entire equipment shall be designed to ensure satisfactory and safe operation under the running conditions mentioned in this specification duly taking care of sudden variations in load, voltage etc. under abnormal working conditions due to faulty operation, short circuits & earth faults etc.
- vi. As Applicable: Airflow inlet/ arrangement for forced cooled equipment shall be designed in such a way that cloth, polythene, papers etc., which may get sucked, either do not block the airflow or get removed during halts. Moreover, filter should be easily cleanable.
- vii. All working parts of the control and auxiliary circuit specifically electronics and PCBs, shall be suitably covered to keep them free from moisture, mould growth and dust. The protection level shall be furnished by the Supplier during design approval.
- viii. All the electrical equipment shall comply with the latest edition of governing IEC specifications unless otherwise specified. The temperature rise shall be measured according to the procedure

	<b>Technical Specification for Passenger Alarm system</b>	<b>PROJECT</b> Vande Bharat 80 rakes
	Doc. No.: PS4452988 - Part A, Rev. 00	

stipulated by IEC and shall comply with the limits specified and the ambient conditions defined in the Specification.

- ix. All equipment shall be adequately earthed, insulated, screened or enclosed. They shall be provided with essential interlocks & keys as may be adequate to ensure the protection of the equipment and the safety of those concerned with its operation and maintenance.
- x. If Applicable: Supplier shall to the extent feasible employ the currently available lubricants/cooling oils in India. Full lubrication scheme and schedule for the equipment shall be submitted. If use of imported lubricants or cooling oil is inevitable, supplier shall furnish details of equivalent Indian lubricants/oil.
- xi. Supplier shall submit list of equipment and facilities required for maintenance and overhaul of equipment offered.
- xii. Supplier shall submit 3D models of propulsion & other equipment, cooling system, driver/shunting desk, cab layout and roof/under frame/HT compartment layouts populated with equipment etc.
- xiii. The design of the equipment shall be based on sound, proven and reliable engineering practices. The equipment used in different sub systems shall be of proven technology and design. The supplier shall submit the supportive document for each of the assembly/sub-assembly for its proven performance under the environmental conditions prevalent in India.
- xiv. The supplier shall design the mounting arrangements suitable for coaches to be manufactured by IR. The accessories for mounting the equipment shall be in the scope of supply. The hardware for mounting, safety links for underslung equipment, the termination hardware also will be in the scope of supply all equipment.
- xv. Software (If Applicable)
  - a) Software shall be written in a structured manner and fully documented during all stages of its design and development. This shall meet the requirements of EN 50126-2: The specification and Demonstration of Reliability, Availability, Maintainability and Safety (RAMS) - Part 2, EN 50128: Railway Applications: Software for Railway Control and Protection Systems, and EN 50129: Safety-related Electronic Railway Control and Protection Systems.
  - b) Logic of the Software of various sub-systems shall be approved by RDSO in consultation with user Railways at the design approval stage. The Supplier shall submit the values of parameters, list of fault messages, their environmental data, hierarchy of fault display, fault categorization, trouble shooting of each fault by way of graphical representation on HMI etc. for the approval. Changes in parameters shall be demonstrated with their effect on the results.
  - c) The Supplier shall submit software logic with detailed explanation along with complete software packages used in TCMS and Converter control before commissioning of the prototype rake. Parametric changes shall be possible in the software in order to meet the future requirements viz. change in acceleration & deceleration, bogie & coach suspension, train configurations, OHE voltage, frequency etc. within permissible limits. While listing out the values of various parameters, the Supplier must provide a range within which any change can be made without jeopardizing the functionality of the system. Supplier shall submit one copy of the licensed software to the user Railway before uploading the same on the train.
  - d) Software shall be fine-tuned through simulations & real life working conditions based on the extensive trials, associating user Railways before putting the rake in commercial services. As it requires, instrumentation and expertise of Software Design Professionals, software expert(s) of Supplier shall be based at the work place along with commissioning engineers so



## Technical Specification for Passenger Alarm system

Doc. No.: PS4452988 - Part A, Rev. 00

**PROJECT**  
Vande Bharat 80  
rakes

that all software related issues are expeditiously resolved before putting the rake into commercial service.

- e) Quality and efficacy of trouble shooting manual, software tools and software documentation shall be validated during extensive field trials. Final version of these documents shall include the changes required based on the service trials, commercial service operation, experience of operating Railways and shall be submitted after the expiry of the warranty period of the prototype rakes.
  - f) All the changes, thereafter, in software shall be approved by RDSO in consultation with user Railways before actual implementation and the Supplier must give software release, which shall include brief description of the problem, earlier as well as modified logic, explanation, parametric changes etc. to the satisfaction of RDSO.
  - g) Internal independent review, verification & testing, using real & synthetic data, shall be performed at the software module and system level. RDSO/user Railway may audit the Supplier against the Software Quality Plan at any stage during the Contract. The Supplier shall ensure that all software is fully de- bugged prior to the final review by RDSO/user Railway.
  - h) Sufficient software documentation shall be provided to give the full understanding of the software function, logics, parameters and operation. Documentation shall be complete, clear and concise, and include all modifications up to the final acceptance. Documentation shall clearly explain the software logics, associated parameters, include software block diagram showing signal flow, logic and hardware interfaces etc. A top level flow diagram and description of detailed operation shall be provided.
  - i) The Supplier shall submit Software Quality Plan for review before work commences on software design. The software quality plan shall clearly state the controls and practices used in the software life cycle from specification through to in-service operation.
- xvi. Notwithstanding the contents of this specification, the supplier shall ensure that the equipment supplied by them is complete in all respect so as to enable the desired operation of the Train 18 (Trainset) / EMU fitted with their equipment.

### 3.4 Train Formation

#### 16 car Formation:

Basic Unit (BU) - 1	Basic Unit (BU) - 2	Basic Unit (BU) - 3	Basic Unit (BU) - 4
DTC1-MC1-TC1-MC2	MC3-TC2-MC4-NDTC1	NDTC2-MC4-TC1-MC3	MC2-TC2-MC1-DTC1

DTC: Driving Trailer Coach, MC: Motor Coach, NDTC: Non-Driving Trailer Coach, TC: Trailer Coach

### 3.5 Ingress Protection

All equipment shall be suitably protected from dust and water. As a minimum, equipment shall be sealed to the standards stated below:

Under frame & externally mounted equipment (other than traction/ auxiliary converter/Traction Motor)	IP65
Battery Box and Brake Chopper	IP20
Equipment mounted inside the Car body	IP54

### 3.6 Ambient Conditions / Operating Conditions

These Train set are operating at 25 kV AC OHE voltage fed through catenary and vacuum circuit breaker mounted on the roof of the motor coach. The incoming power supply is fed to the primary of



## Technical Specification for Passenger Alarm system

**PROJECT**  
Vande Bharat 80  
rakes

Doc. No.: PS4452988 - Part A, Rev. 00

the main transformer and stepped down to a lower voltage, converted into AC voltage through IGBT based Converter and inverters and fed to four (04) parallel connected 3 phase traction motors.

The equipment shall be designed to work satisfactorily under following environmental conditions –

Relative Humidity	up to 100% saturation during monsoon season
Ambient temp.	Max. 50° C, Min. -10° C
Stationary rake temperature	<p>The temperature of stationary Car in sun may go as high as 70° C. The equipment shall not be adversely affected in any way due to exposure to such high temperatures. Supplier shall furnish the precautions taken in equipment/component selection in order to conform to this requirement. The Supplier will indicate the expected temperature rise of equipment under the reference site conditions described above and shall submit the expected MTBF/MDBF at such temperature.</p> <p>The equipment shall function in accordance with this Specification following any period when stationary at the maximum ambient temperature and in full sunlight as specified in this clause, in other words any pre-cooling of equipment shall not be required.</p>
Altitude (Max)	1600 meter
Rainfall	Very heavy and continuous between 0 and 100 mm / hour (up to 2500 mm during rainy season).
Flood proofing of underslung equipment	All under slung equipment shall be designed suitably to ensure its normal working even in adverse conditions as mentioned in this Clause.
Atmosphere during hot weather	<p>Extremely dusty, humid and salty. The Train shall be working in coastal area also and thus may be continuously exposed to highly corrosive, salty atmosphere along with industrial pollutants. The equipment shall function in accordance with this Specification when subjected continuously to an atmosphere containing dust in concentrations up to 1.6 mg / m<sup>3</sup>.</p> <p>The equipment shall function in accordance with this Specification when subjected continuously to an atmosphere containing dust in concentrations up to 1.6 mg / m<sup>3</sup>.</p> <p>The equipment shall function in accordance with this Specification when subjected continuously to a humid and salt laden atmosphere with maximum pH value of 8.5, sulphate content of 7 mg per litre, maximum concentration of chlorine 6 mg per litre and Maximum conductivity of 130 micro Siemens / cm.</p> <p>The equipment shall function in accordance with this Specification when subjected to high wind speed in certain areas, with wind pressure reaching 150 kg/m<sup>2</sup>.</p> <p>Equipment shall function in accordance with this Specification when exposed to solar radiation in the range from 0 kW/m<sup>2</sup> to 1 kW/m<sup>2</sup>.</p> <p>Special care shall be taken to ensure no damage to equipment</p>

	<b>Technical Specification for Passenger Alarm system</b>	<b>PROJECT</b> Vande Bharat 80 rakes
	Doc. No.: PS4452988 - Part A, Rev. 00	

	<p>due to deposition of atmospheric salts and industrial pollutants. Supplier shall enclose the details of specific measures adopted to ensure the satisfactory working of equipment against the deposition of salts &amp; industrial pollution.</p>
Vibrations	<p>Because of track irregularities, level of shocks and vibrations to which traction motors are exposed are far more than actually given in IEC for TM mounting arrangement. Supplier to carry out instrumented trials if considered desirable on existing stock for measurement of shocks and vibrations in consultation with RDSO at design stage. The suspension system and the mounting arrangement of underslung / bogie mounted equipment shall be so designed that the equipment performance is not adversely affected due to such high vibrations and shocks.</p>

### 3.7 Standards

The equipment covered by the specification shall be designed, engineered, manufactured, built, tested and commissioned in accordance with the Acts, Rules, Laws and Regulations of India.

The equipment to be furnished under this specification shall conform to latest issue (with all amendments) of specified standards.

The standards applicable and relevant to the complete Train and to the various systems and sub-systems shall be:

IEC publications; EN; UIC; IEEE; BS; RDSO specifications; Indian Standards;

In the event of any contradiction in the aforesaid standards, the following standards shall have priority in the order listed:

Standards specifically mentioned in the relevant clause of Specification; IEC/EN/UIC/IEEE/BS/ISO and IS/other RDSO Specifications.

For avoidance of any doubt, in case of any conflict between the requirements of above standards, the stipulations of this Specification shall have precedence.

The latest version of the aforesaid codes, standards and specifications, which have been published at least 60 days before the last date of bid submission shall be considered applicable.

The standards stipulated in this Specification are the minimum. The Supplier may adopt alternative internationally recognized codes, standards and specifications, if it can demonstrate to the Purchaser/ RDSO that such alternative is superior or more pertinent to meet the requirement of this specification. The Supplier shall seek prior written approval of the Purchaser for any alternative specifications and standards proposed to be used. Where no standard is identifiable the Supplier shall make a proposal based on the best International practice, which shall be subject to review/ acceptance by RDSO.

### 3.8 Engineering Data

#### 3.6.1 Drawings

The contactor shall necessarily submit all the drawings/ documents unless anything is waived. The contactor shall submit 6 (six) sets of drawings/ design documents/ data/ test reports as may be required for the approval of the purchaser. All drawings submitted by the Manufacturer including those submitted at the time of bid shall be in sufficient detail to indicate the type, size, arrangement, material description, Bill of Materials, weight of each component, break-up for packing and shipment, the external connections, fixing arrangement required, dimensions required for installation and interconnections with other equipment and materials, clearances and spaces required for installation

	<b>Technical Specification for Passenger Alarm system</b>	<b>PROJECT</b> Vande Bharat 80 rakes
	Doc. No.: PS4452988 - Part A, Rev. 00	

and interconnections between various portions of equipment and any other information specifically requested in the specifications.

Each drawing submitted by the Manufacturer shall be clearly marked with the name of the Customer and Project, the unit designation, the specifications title, the specification number, date of revision (if any), duly signed by the concerned technical person. If standard catalogue pages are submitted, the applicable items shall be indicated therein and should be made project specific. All titles, noting, markings and writings on the drawing shall be in English. All the dimensions should be in metric units.

Further work by the Manufacturer shall be in strict accordance with these drawings and no deviation shall be permitted without the written approval of the Purchaser, if so required.

All manufacturing and fabrication work in connection with the equipment prior to the approval of the drawings shall be at the Manufacturer's risk. The Manufacturer may make any changes in the design which are necessary to make the equipment conform to the provisions and intent of the Contract and such changes will again be subject to approval by the Purchaser. Approval of Manufacturer's drawing or work by the Purchaser shall not relieve the manufacturer of any of his responsibilities and liabilities under the Contract.

All engineering data submitted by the Manufacturer after final process including review and approval shall form part of the Contract Document and the entire works performed under these specifications shall be performed in strict conformity, unless otherwise expressly requested by the Owner in Writing.

The title block of drawings shall contain the following information incorporated in all contract drawings

<b>1. Customer :</b> BHEL /Indian Railways
<b>2. Project:</b> Manufacturing cum Maintenance of Vande Bharat Trainsets
<b>3. Contract No./LOA No. :</b> RAILWAY BOARD (CPC- 046500000) MAIN ORDER CCN- ID1237002
<b>4. Main Contractor :</b> Bharat Heavy Electricals Limited
<b>5. BHEL Order No. &amp; Date :</b>

### Size of Drawings

The drawings of the following parts shall be to the sizes indicated below

- i. Equipment details – full size or half size
- ii. Motor Assemblies – 1:5
- iii. General Assemblies- 1:10

The dimensions, weight, capacity, etc. shall be in SI units. All drawings shall be submitted on CDs along with complete setup with software for reading and taking prints through desk top PC and suitable printer. In case the format is not compatible with AUTOCAD necessary customized hardware and software shall be submitted.

	<b>Technical Specification for Passenger Alarm system</b>	<b>PROJECT</b> Vande Bharat 80 rakes
	Doc. No.: PS4452988 - Part A, Rev. 00	

### Method of Filing of Drawings

To facilitate filing of drawings, it is essential that each drawing submitted for approval is marked so that it can be identified. The supplier is, therefore, required to ensure that all prints are marked legibly at the right hand bottom corner. The following information is required in respect of each drawing:

Supplier's drawing number.

Supplier's name and date of submission.

Contract no. given by the purchaser.

Description of drawings.

Relevant Specifications

### Photographs

While the prototype equipment is under manufacture/ assembly, photographs of the various assemblies and sub-assemblies in various stages of production shall be taken. Photograph size shall not be less than 305 x 203 mm. Photographs shall be submitted in the form of books suitably bound with a cover of superior quality & durable material with the title block printed on the cover. Photographs/ short interval video clips on digital media shall also be furnished.

### 3.9 Marking of Equipment & Rating Plate

All main assemblies of the equipment shall bear serial number, year of manufacture and symbol/ identification of the purchaser. Where the sub- assemblies/components of the main assemblies are not inter-changeable, the sub-assemblies shall also be marked with the serial nos. of the main assembly of which they form a part.

All equipment/cubicles shall contain non-detachable rating plates of anodized aluminium with embossed letters and fitted in a visible position. The rating plate will give detailed rating specification and identification of equipment.

The details of rating plate of each of the equipment shall be as approved by RDSO.

### 3.10 Infringement of Patent Rights

BHEL and Indian Railway shall not be responsible for infringement of patent rights arising due to similarity in design, manufacturing process, components used in design, development and manufacturing of propulsion system & other equipment and any other factor which may be a cause such dispute. The responsibility to settle any issue lies with the manufacturer.

### 3.11 Document Submissions

Sl.no.	No. of copies	Schedule
i)	Initial Submission Drawings, Data sheets, Type test Reports	At the time of submission of offer.
ii)	Furnishing of drawings in hard / soft copy format	Approx. 2 to 3 weeks from the date of award of contract.
iii)	Furnishing of type test reports in hard / soft copy format	Hard / soft copy to be submitted immediately after the completion of the test.
iv)	Furnishing of routine test reports	Hard / soft copy to be submitted immediately after the completion of the test.
v)	All documents including Installation, Operation & Maintenance manuals.	Approx. 2 to 3 weeks from the date of award of contract.

	<b>Technical Specification for Passenger Alarm system</b>	<b>PROJECT</b> Vande Bharat 80 rakes
	Doc. No.: PS4452988 - Part A, Rev. 00	

### 3.12 Quality Assurance Programme

To ensure that the equipment and services under the scope of this Contract, whether manufactured or performed within the Manufacturer's Works or at his Sub-manufacturer's premises or at the Purchaser's site or at any other place of Work, are in accordance with the specifications, the Manufacturer shall adopt a suitable quality assurance program to control such activities at all points, as necessary. Such program shall be outlined by the Manufacturer and shall be finally accepted by the Purchaser after discussions before the award of Contract.

A quality assurance program of the manufacturer shall generally cover the following:

- a) Manufacturer's organization structure for the management and implementation of the proposed quality assurance program;
- b) Documentation control system;
- c) Qualification data of bidder's key personnel;
- d) The procedure for purchases of materials, parts components and selection of sub-Manufacturer's services including vendor analysis, source inspection, incoming raw material inspection, verification of material purchases etc.
- e) System for shop manufacturing and site erection controls including process controls and fabrication and assembly control;
- f) Control of non-conforming items and system for corrective actions;
- g) Inspection and test procedure both for manufacture and field activities;
- h) Control of calibration and testing of measuring instruments and field activities;
- i) System for indication and appraisal of inspection status;
- j) System for quality audits;
- k) System for authorizing release of manufactured product to the Purchaser
- l) System for maintenance of records;
- m) System for handling storage and delivery; and
- n) A quality plan detailing out the specific quality control measures and Procedures adopted for controlling the quality characteristics relevant to each item of equipment furnished and/or services rendered.

The Purchaser or his duly authorized representative reserves the right to carry out quality audit and quality surveillance of the system and procedure of the Manufacturer/'his vendor's quality management and control activities.

#### Quality Assurance Documents

The Manufacturer shall be required to submit the Quality Assurance Documents as stipulated in the quality plan at the time of purchaser's inspection of equipment/ material.

### 3.13 Type and Routine Testing & Inspection

1. The individual prototype equipment, systems and sub systems shall be type and routine tested in accordance with the relevant IEC/UIC/EN publications inclusive of the mandatory and optional tests along with the special tests as specified.
2. All type tests shall be conducted by Supplier or such other agency or person agreed by RDSO at the Supplier's cost where ever performed in presence of and to the satisfaction of RDSO, who reserves the right to witness any or all of the tests. All tests set forth in this specification shall be conducted by the Supplier or other agency or competent person as agreed by the purchaser/ RDSO.
3. RDSO may waive some of these tests in case of equipment/ sub-assemblies where the manufacturer can establish to the satisfaction of RDSO that such tests have already been carried



## Technical Specification for Passenger Alarm system

**PROJECT**  
Vande Bharat 80  
rakes

Doc. No.: PS4452988 - Part A, Rev. 00

out earlier. In such a case, manufacturer shall submit complete test reports along with necessary certification.

4. Wherever any equipment, system, sub system is not specifically covered by an international recognized specification or test procedure, the tests which are acceptable to both to Supplier and to the IR's representative shall be devised.
5. Without prejudice to any provisions of the contract, the purchaser reserves the right to witness any or all of the type tests and to require submission of any or all test specification and reports.
6. The Supplier shall arrange instrumentation and record speed, voltage, current, temperature rise of various equipment, energy consumption, tractive effort and other relevant parameter as necessary for ensuring Complied of the Specifications.
7. In case any bidder indicates that he shall not carry out a particular test, his offer shall be considered incomplete and shall be liable to be rejected.
8. The Purchaser, his duly authorized representative and/or outside inspection agency acting on behalf of the Purchaser shall have at all reasonable times free access to the Contractors premises or Works and shall have the power, at all reasonable times to inspect and examine the materials and workmanship of the works during its manufacture or erection if part of the Works is being manufactured or assembled at other premises or works, the Manufacturer shall obtain for the Engineer and for his duly authorized representative permission to inspect as if the works were manufactured or assembled on the Manufacturer's own premises or works. Inspection may be made at any stage of manufacture, dispatch or at site as the option of the Purchaser and the equipment if found unsatisfactory due to bad workmanship or quality, material is liable to be rejected.
9. In all cases where the Contract provides for tests whether at the premises or at the works of the Manufacturer or of any Sub-Contractor, the Manufacturer except where otherwise specified, shall provide free of charge items such as labour, materials, electricity, fuel, water, stores, apparatus and instruments as may be reasonably demanded by the Purchaser /Inspector or his authorized representative to carry out effectively such tests of the equipment in accordance with the Contract and shall give facilities to the Purchaser Inspector or to his authorized representative to accomplish testing.
10. The inspection by Purchaser and issue of Inspection Certificate thereon shall in no way limit the liabilities and responsibilities of the Manufacturer in respect of the agreed quality assurance program forming a part of the Contract.
11. The Purchaser reserves the right for getting any field tests not specified in respective sections of the technical specification conducted on the completely assembled equipment at site.
12. During the prototype tests/trials or services, if any problems arise or feedback information is obtained, which warrants a re-check of the design/manufacture/quality of the equipment and components, action will be taken as may be necessary by the Supplier to carry out the required investigations and to incorporate the improvements considered most appropriate to reach compliance with the specification without any extra costs to the Purchaser.
13. The prototype rakes fitted with the supplied equipment, shall be subjected to pre-revenue service trials. Service trials are intended to prove the satisfactory running performance of the supplied Train set equipment and evaluate their reliability in service, ease of maintenance and operations. The performance of the equipment shall be assessed based on the experience gained during the service trials. Necessary modification as required and also as desired by the RDSO/Indian Railway shall be implemented in the series production without any extra costs to the Purchaser.

### **Tests on Control electronics and PCBs:**



## Technical Specification for Passenger Alarm system

Doc. No.: PS4452988 - Part A, Rev. 00

**PROJECT**  
Vande Bharat 80  
rakes

Control Electronics shall be tested as per IEC 60571/EN50155 IEC 60068, IEC 60721-2-5 and IEC 61373 including both compulsory and optional tests.

Following tests shall be carried out on the PCBs as per IEC 60571/EN 50155 and IEC 61373 with the modified parameters.

- a) **Dry Heat test:** Dry Heat test shall be done at 80 °C. Along with the testing for the satisfactory performance, temperature stickers shall be put on the critical ICs, Controllers & capacitors etc. for monitoring the maximum temperature of these components during dry heat tests. It shall be confirmed that the temperature recorded during dry heat test as above does not exceed the specified operating/surface temperature of these components. For the purpose, data sheets of such components shall be referred and submitted during testing.
- b) **Cyclic Humidity test:** The tests shall be done for 2 cycles of 24 hours each and components shall be examined for the performance tests **and** physical damage if any. The humidity cycle shall be as specified in IEC 60571.
- c) **Salt Mist Test:** The test duration shall be 48 hours and after the tests the performance test shall be done. There shall be no physical **damage**, rusting or deterioration of the varnish/lacquer coating.
- d) **Dust & Sand Test & Mould growth test:** The tests to determine the performance of the electronics in Sand and Dust ambient shall be carried out with the dust settlement rate of 6gm/m<sup>2</sup>/day. The dust particle size shall not be larger than 100 µm. Further details shall be worked out at design stage. The reference IEC shall be IEC 68; test Dust and Sand and IEC721-2-5 test Dust and Sand. The **component** shall be protected against mould/fungal growth. The test scheme shall be finalized during design stage.

### 3.14 Materials and Workmanship

Equipment materials and components shall be new, of high grade and good quality and be to the latest engineering practice. The material and workmanship throughout shall be in accordance with the purpose for which they are intended. Each component shall be designed to be consistent with its duty. All the information concerning materials or components to be used in manufacturing, machinery, equipment, materials and components supplied, installed or used shall be submitted for approval. Without such approval the supplier shall run risk of subsequent rejection. The cost as well as time delay associated with such rejection shall be borne by the supplier.

### 3.15 Packing and Storage

All the equipment's shall be suitably protected, coated, covered or boxed and crated to prevent damage or deterioration during transit, handling and storage at site till the time of erection. On request of the purchaser, the manufacturer shall also submit packing details/ associated drawing for any equipment/ material at a later date, in case the need arises.

The manufacturer shall be responsible for any loss or damage during transportation, handling and storage due to improper packing. Any demurrage and other such charges claimed by the transporters, railways etc. shall be to the account of the manufacturer.

All coated surfaces shall be protected against abrasions, impact, discoloration and any other damages. All exposed threaded portions shall be suitably protected with either a metallic or a non-metallic protecting device.

Supplier shall ensure that equipment shall be properly packed, blocked, padded, coated and protected so that it is not damaged due to possible mishandling. Storage requirements shall be clearly defined

	<b>Technical Specification for Passenger Alarm system</b>	<b>PROJECT</b> Vande Bharat 80 rakes
	Doc. No.: PS4452988 - Part A, Rev. 00	

by the supplier. Packing shall be such that if required, long time storage at site should not deteriorate the performance of the equipment.

### 3.16 Fire Prevention

The equipment's shall be designed to minimize the risk of any fire. The design of equipment shall incorporate all measures to prevent fire and will be such that should any fire take place the effects shall be minimized and no spread of fire should take place. Materials that are not fire retardant shall not be used.

Materials used in the manufacture of equipment's shall be selected to reduce the heat load, rate of heat release, propensity to ignite, rate of flame spread, smoke emission and toxicity of combustion gases.

The Supplier shall comply with standard EN 45545 HL-3 for all equipment under scope of supply. All safety features in design, construction and materials used shall conform to the best safety standards and shall in particular prevent fires in Train in accordance with Good Industry Practice.

### 3.17 Maintenance Manual, Spare Parts Catalogue & Material Specification

The detailed maintenance and service manual (including the trouble shooting directory shall be prepared for the various equipment's and 3 sets of hard copies & soft copy of the same shall be supplied free of charge.

Detailed spare parts catalogue listing all components manufactured or purchased by the supplier along with their rating, source & schematic position etc. (04 copies) each shall also be supplied free of charge.

The documentation shall be provided on compact discs & pen drives (02 no's) along with relevant software and complete arrangements to read them or edit them in future to take prints in color.

Supplier shall submit the 3D models (for interface purposes) in SolidWorks and 2D drawings in AUTOCAD. To ensure tool independent exchange of models, step-files shall also be submitted. The complete documentation shall be provided on digital storage media along with relevant software and complete arrangement to read, edit and to take prints in color. In case the drawing format is not compatible with AUTOCAD, necessary customized hardware and software shall also be submitted.

	<b>Technical Specification for Passenger Alarm system</b>	<b>PROJECT</b> Vande Bharat 80 rakes
	Doc. No.: PS4452988 - Part A, Rev. 00	

## Section 4

# Reliability, Availability, Maintainability And Safety (RAMS)

### 4.1 Key Performance Indicators

Performance indicators comprises of Availability, Reliability and upkeep of Cars. The bidder must ensure RAMS parameters for the offered equipment and its sub-assemblies supplied to at least maintain the overall fleet availability and reliability targets given below. In case, fleet reliability drops on account of poor reliability of subassemblies supplied, the supplier will be required to improve the quality of subassemblies to match the availability & reliability targets.

#### a) Availability

Sum of Available Hours as a proportion of the total hours (Available Hours + Non-Available Hours) in the Fleet in any Accounting Year, shall be considered as "Availability". Guaranteed Availability in every Accounting Year shall be at least 95%.

#### b) Reliability

Average Mean distance travelled between two Failures for the fleet in any Accounting Year shall be considered as "Reliability". Guaranteed Reliability shall not be less than 200,000 km.

#### c) Upkeep

For the offered equipment, there shall be no such conditions during the operation of trains that affects the reliability, safety and passenger amenities. Any maintenance shall be conterminous with the train maintenance schedules as given in CI 4.5 of this section.

List of Conditions affecting Upkeep (As applicable) is enclosed as Annexure-4-A of this section.

### 4.2 Reliability Availability Maintainability and Safety (RAMS)

- a. The supplier shall ensure that, Guaranteed Reliability, Guaranteed Availability and High Degree of Safety in order to provide a dependable service, forms an integral element of the offered products.
- b. The plan for Reliability, Availability, Maintainability and Safety shall conform to EN 50126/ IEC 61709/ IEC 62278. Reliability of electronic components shall conform to IEC 61709.
- c. The supplier shall develop and provide RAMS targets (MTBF/MDBF/MTBSF) for the offered equipment both for the complete system and for the major Sub-systems at ambient temperature up to 50°C.
- d. After rectification of any failure / fault, the concerned equipment / system should resume its original performance / function.
- e. Components critical for safety shall fall into safe operating mode in case of malfunctioning. The system safety plan shall identify and list safety critical components and this list shall be updated periodically and intimate to the purchaser.
- f. Supplier shall submit the basic maintenance schedules of the proposed equipment. Minimum interval between two maintenance schedules in the depot for the equipment supplied should not be less than 90 days except for activities which can be done outside the base depot (such as cleaning of filters mounted in the under-frame, for which the periodicity shall not be less than 15 days) and 3 years for major works in workshop/major depot. Average running distance of a rake may be considered as 2000 kilometer per day. Please refer CI 4.5 below in respective planning of maintenance schedule for the supplied equipment.

	<b>Technical Specification for Passenger Alarm system</b>	<b>PROJECT</b> Vande Bharat 80 rakes
	Doc. No.: PS4452988 - Part A, Rev. 00	

- g. All systems, components and structural areas serviced as part of inspection or periodic preventive maintenance shall be conveniently accessible for service and inspection.

#### 4.3 RAMS Documentation

Vendor shall agree to submit following documents pertaining to RAMS analysis:

- Functional breakdown + inherent failure analysis
- Mission critical failures Analysis (Fault Tree Analysis)
- FMECA (Failure Mode Effects and Criticality Analysis)
- System/Sub-Systems Hazard Analysis
- Hazard Log + SIL data (if applicable)
- List of critical components
- Preventive Maintenance Analysis
- Corrective Maintenance Analysis

#### 4.4 Service Life of Equipment/System

Vendor shall specify the service life of the offered equipment / system based on life cycle calculations after which the equipment / system shall call for complete replacement to maintain the required reliability & availability of fleet.



## Technical Specification for Passenger Alarm system

Doc. No.: PS4452988 - Part A, Rev. 00

**PROJECT**  
Vande Bharat 80  
rakes

### Annexure-4-A

List of Conditions affecting Upkeep of Trains. This is an indicative list. Supplier shall provide data and documentation as per section 4.

S.No.	System name	Condition
1	Windscreen Wiper and Washer System	- Rainy weather, defective wiper in any cab.
2	Couplers (any type)	- Any mechanical/electrical/pneumatic fault and/or any dimensional misalignment and/or any damage to any part which does not allow the coupler to guarantee the fulfilment to its assigned mission, in accordance to the technical requirements, performance and safety set out in this specification.
3	Suspension	- Any defect in primary / secondary suspension resulting in passenger safety, comfort or performance.
4	Wheel	- If wheel flat is > 40 mm or as finalised in design. - Any abnormal hammering as reported by the TO.
5	Pantograph	- Isolation of any pantograph
6	Transformer	- Isolation of any one main transformer.
7	Battery charger	- Battery Charger of one unit isolated.
8	Mechanical drive system	- Any defect resulting in high temperature / isolation
9	Traction Motors	- Isolation of more than 25%motors.
10	Traction converters	- As per the consequential effect as defined in Item 10 above.
11	Main compressor unit	- Isolation of any Main Compressor Unit
12	Auxiliary converter-inverter	- Isolation of any Auxiliary Converter-Inverter unit.
13	Brake system (mechanical)	- If isolation of an additional bogie (mechanical) leads to speed restriction.
14	Exterior lights	- Failure of any head light / marker/tail light.
15	Driver's desk	- If master controller prevents the train from moving. - Any defect in master controller even if no delays are reported. - Any defective cab switch leading to unsafe operation.



## Technical Specification for Passenger Alarm system

**PROJECT**  
Vande Bharat 80  
rakes

Doc. No.: PS4452988 - Part A, Rev. 00

16	TCMS & Vehicle circuits	<ul style="list-style-type: none"> <li>- If HMI display fails &amp; functionality is not transferred to redundant HMI.</li> <li>- Any failure in TCMS component / equipment /circuit element / software/communication system etc. resulting in loss of intended function.</li> <li>- Further cases will be included based on TCMS redundancy and configuration.</li> </ul>
17	PIS & CCTV	<ul style="list-style-type: none"> <li>- If both automatic and manual announcements fail</li> <li>- If announcements in Car is not audible</li> <li>- if <math>\geq 1</math> unit exterior side view CCTV not working</li> <li>- If <math>&gt;1</math> PEA in any car is defective</li> <li>- One saloon CCTV, including its backup if any, is isolated.</li> <li>- If <math>\geq 1</math> unit for rear cab and front cab camera, cameras on the roof</li> </ul>
18	Passenger doors	<ul style="list-style-type: none"> <li>- If <math>\geq 1</math> (one) door per train side is isolated.</li> </ul>
19	HVAC (passenger area)	<ul style="list-style-type: none"> <li>- Failure of any one HVAC in any car leading to increase in inside temperature <math>\geq 28^{\circ}\text{C}</math></li> <li>- Failure of two HVAC's in one car.</li> <li>- Noisy Air Conditioner: Interior Noise <math>&gt;+2\text{dB}</math> than the one recorded and validated during the type test at standstill)</li> </ul>
20	Ground fault in DC Circuit	<ul style="list-style-type: none"> <li>- Train to be withdrawn in case of single ground fault if it leads to unsafe operation as per the design.</li> </ul>
21	A failure or symptom which may endanger safe and/or normal operation of train	<ul style="list-style-type: none"> <li>- Failure in safety interlock or protection circuit such as door loop</li> <li>- Abnormal noise in underframe</li> <li>- Wheel flat</li> <li>- Arcing in pantograph</li> <li>- Failure of emergency equipment</li> <li>- Failure which may disable train's push out duty.</li> <li>- Train which that requires more than 2 instances of reset within 30 minutes</li> <li>- Jerky movement (The details shall be finalized in design stage).</li> <li>- Others to be decided during design stage</li> </ul>

**Note:** The above list shall be further reviewed and updated during design stage.

#### 4.5 Train Maintenance Schedule (Tentative)

Sl. No.	Schedule	Place of maintenance	Permissible time per schedule	Periodicity
1	Minor maintenance	Light maintenance at Depot	8 hours	3 months
2	AOH	Light maintenance at Depot	7 days	18 months
3	IOH	Heavy maintenance at Depot	10 days	36 months
4	POH	Heavy maintenance at Depot	20 days	72 months



## Section 5

### Spares and Consumables for Maintenance

#### 5.1 Spares and Consumables

- i) Supplier shall provide complete list of items/materials which get consumed during normal course of operation of the Train as applicable for the equipment/system (the “Consumables”).
- ii) Supplier shall provide complete list of parts or equipment/system ensuring fleet availability of 95% or better, which would be necessary for efficient operation and maintenance of the (the “Spares”).
- iii) Supplier shall provide detailed spare parts catalogue / data-sheet listing all components manufactured or purchased by the supplier along with their rating, source, type / model no., schematic, position, etc.
- iv) Price for above spares and consumables to be shared separately as part of commercial offer.

#### 5.2 Scheduled Maintenance

- a) Scheduled (Preventive) maintenance consists of operations to maintain an assembly/subassembly or components in its specific operating conditions by performing –
  - i) periodical inspection and diagnostic tests for prevention of malfunctioning.
  - ii) scheduled replacement of components.
  - iii) checks to be performed at specified time intervals, whose outcome determines whether or not replacements will be required.
  - iv) routine operations, such as filling, topping up, change oil, greasing, adjustments, etc.
  - v) general overhaul of systems and subsystems.
- b) The preventive maintenance schedules required to keep the supplied system in good fettle with requisite reliability and availability would be coterminous with the train maintenance schedules and it should be possible to comfortably complete such maintenance during the time provided for respective train maintenance schedule and in the facility provided (refer Chapter Reliability, Availability, Maintainability and Safety).
- c) Details of Schedule of Periodic / preventive maintenance (the “Scheduled maintenance”) shall be submitted in following sample format:

Nature of inspection / maintenance	Periodicity / Interval	Items to be replaced

- d) Scheduled Maintenance shall ordinarily not be required before a travel of 40,000 km (forty thousand kilometres).
- e) Supplier shall provide plan / activities for periodical inspection and diagnostic test for prevention of malfunctioning
- f) List of facilities including tools & tackles required for carrying out all scheduled maintenance activities to be provided by vendor.
- g) All systems, components and structural areas serviced as part of inspection or periodic preventive maintenance shall be conveniently accessible for service and inspection.

	<b>Technical Specification for Passenger Alarm system</b>	<b>PROJECT</b> Vande Bharat 80 rakes
	Doc. No.: PS4452988 - Part A, Rev. 00	

### 5.3 Unscheduled Maintenance

Unscheduled (Corrective) maintenance consists of maintenance operation which is not scheduled (part of preventive maintenance) as a result of an in-service failure.

The supplier shall be required to provide repair & maintenance instructions to put back the equipment / system back in service.

List of facilities including tools & tackles required for carrying out all unscheduled maintenance activities to be provided by vendor.

### 5.4 Epidemic Defect Warranty

- a. If any identical defect or deficiency affecting Safety, Reliability and Availability of the trains on more than 20% (twenty per cent) of equipment or parts in any rolling period of 36 (thirty-six) months commencing from the second Year of the Supply Period, such defect or deficiency shall be deemed to be an epidemic defect (the "Epidemic Defect") and the supplier shall cover such Epidemic Defect under an epidemic defect warranty.
- b. In case, the Government (Railways) notifies an Epidemic Defect on account of the supplied assembly, the supplier shall remedy such Epidemic Defect on all such Trains where equipment or parts of that particular design or lot are provided, subject to limitation of period elapsed since commissioning as mentioned above in this para.

### 5.5 Operation and Maintenance Manual

- i) Supplier shall provide an operation manual (the "Operation Manual") for the offered equipment / system in soft copy format in English and Hindi language. The Operation Manual shall include (but not limited to) –
  - a) Instructions for troubleshooting;
  - b) Rating and layout of equipment;
  - c) Operating limits of installed systems;
  - d) Control and safety features of the Equipment/System;
  - e) Instructions to Loco Pilots for operation of the Train (if applicable);
  - f) Do's and don'ts for Loco Pilots (if applicable);
  - g) Safety precautions to be taken by the Loco Pilots (if applicable);
- ii) The Maintenance Manual to be provided by supplier shall include –
  - a. All maintenance activities and their periodicities that are required to keep the Train safe and ensure that the prescribed tolerances of systems and components are not exceeded at any time, including any systems relevant to the maximum moving dimensions;
  - b. The inspection program for regularly checking that the Train is safe to continuing in service;
  - c. Assembly & disassembly sequences for the supplies with pictorial playbook guide
  - d. The engineering facilities (such as pit facilities, special tools etc.) necessary for the mandated maintenance;
  - e. Minimum competencies required by staff for the maintenance activities.
- iii) The Maintenance Manual shall ensure that safety critical systems and components on the Train are identified specifically and the minimum testing requirements that must be invoked in the event of their disturbance at examination or repair are defined.

	<b>Technical Specification for Passenger Alarm system</b>	<b>PROJECT</b> Vande Bharat 80 rakes
	Doc. No.: PS4452988 - Part A, Rev. 00	

- iv) Preparation of the Maintenance Manual shall give consideration to inspections, tests and maintenance of the following that have a bearing on safety –
- a. inter-vehicular couplers.
  - b. fire prevention system including safe working of pantry/ sub pantry equipment.
  - c. Auxiliary electrical machines: Integrity and security, earthing condition and integrity, condition of safety labelling.
  - d. Passenger Information System
  - e. Cleaning: Ventilation ducts, filters, bogies and underframe equipment
  - f. Power systems (including protection systems): Integrity and security earthing condition and integrity, condition of safety labelling.
  - g. Pantographs: Integrity and security - dimensions and condition of pantograph head, over-height protection, earthing condition and integrity, condition of safety labelling.
  - h. Train structures and underframes: Integrity and condition of all load bearing members or panels, integrity, operation and security of doors, openable and removable panels, integrity and security of all body mounted equipment, alignment, gangway.
  - i. Safety systems (e.g. Vigilance control device): Functional tests;
  - j. Hydraulic and pneumatic systems: Condition and integrity of hoses, pipework, valves, etc.
  - k. Fire protection systems: Integrity and condition.
  - l. Lighting Systems & Visibility: Headlight, flasher and marker lights, adjustment, intensity
  - m. Speedometers; headlights and marker lights; horn; doors; cattle guard; and bio-vacuum toilets
- v) The instructions within the Maintenance Manuals shall be such as to protect staff working on the Trains, with particular reference to safety precautions and implementing a specified safety condition of the Train prior to starting work.

### 5.6 Obsolescence Management

Supplier is required to manage obsolescence of all equipment, spares and consumables to enable the trains to continue in service for 35 years. This obsolescence management service must include:

- i) Timely identification of any obsolete items of equipment;
- ii) Development of mitigation strategies to minimize the impact of the imminent obsolescence of any item within the offered equipment / system including:
  - Establishing alternative supply paths;
  - Provision of equivalent or interchange parts or equipment
  - Development of replacement products or design modifications to accept market available alternatives.

### 5.7 Training on Maintenance Aspects

Supplier to provide training to undertake scheduled and unscheduled maintenance to purchaser and its designated persons to handle the maintenance of train for 35 years. The duration of training shall be 12 man days.

**ANNEXURE – 1**

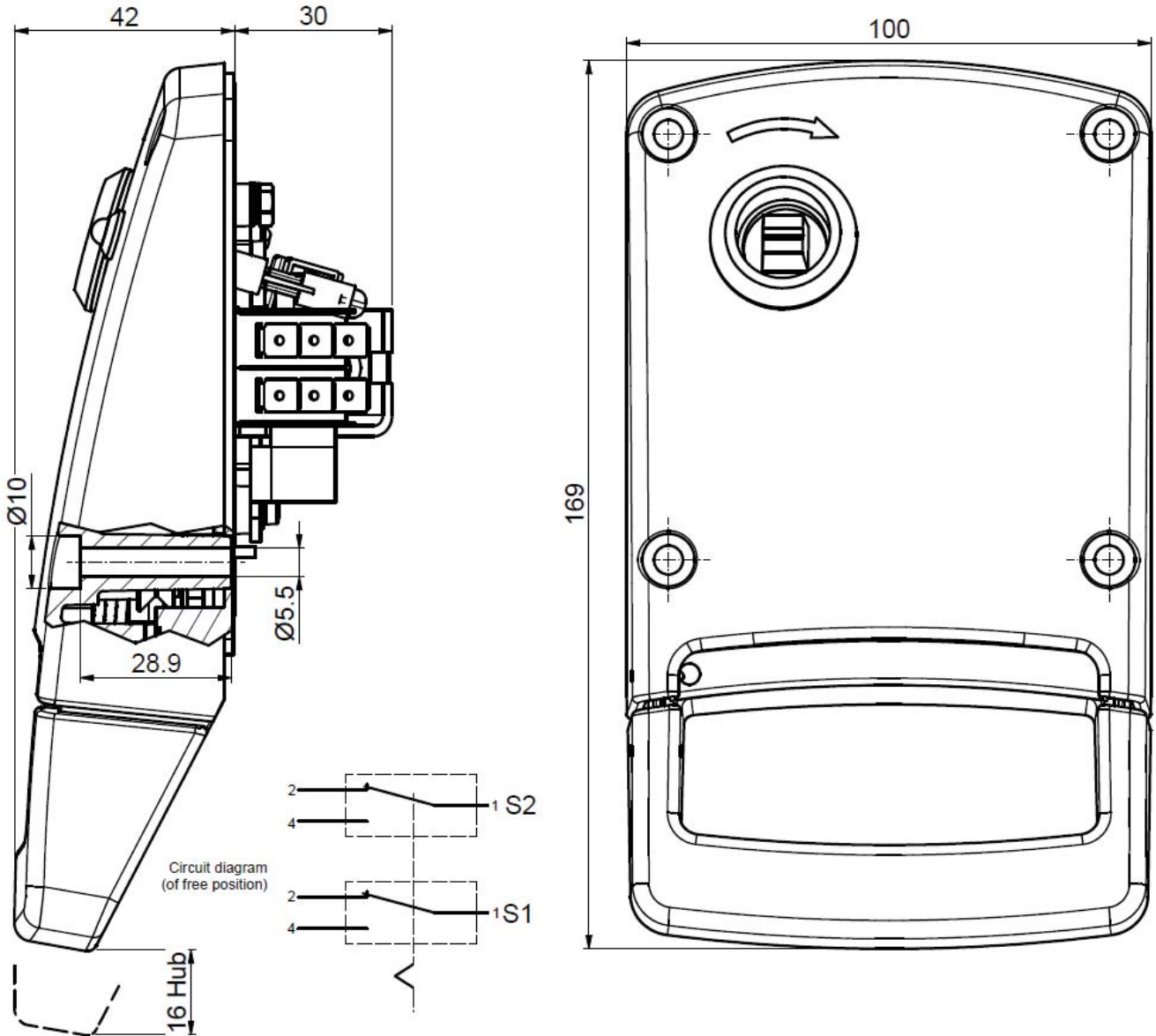

## ANNEXURE – 2

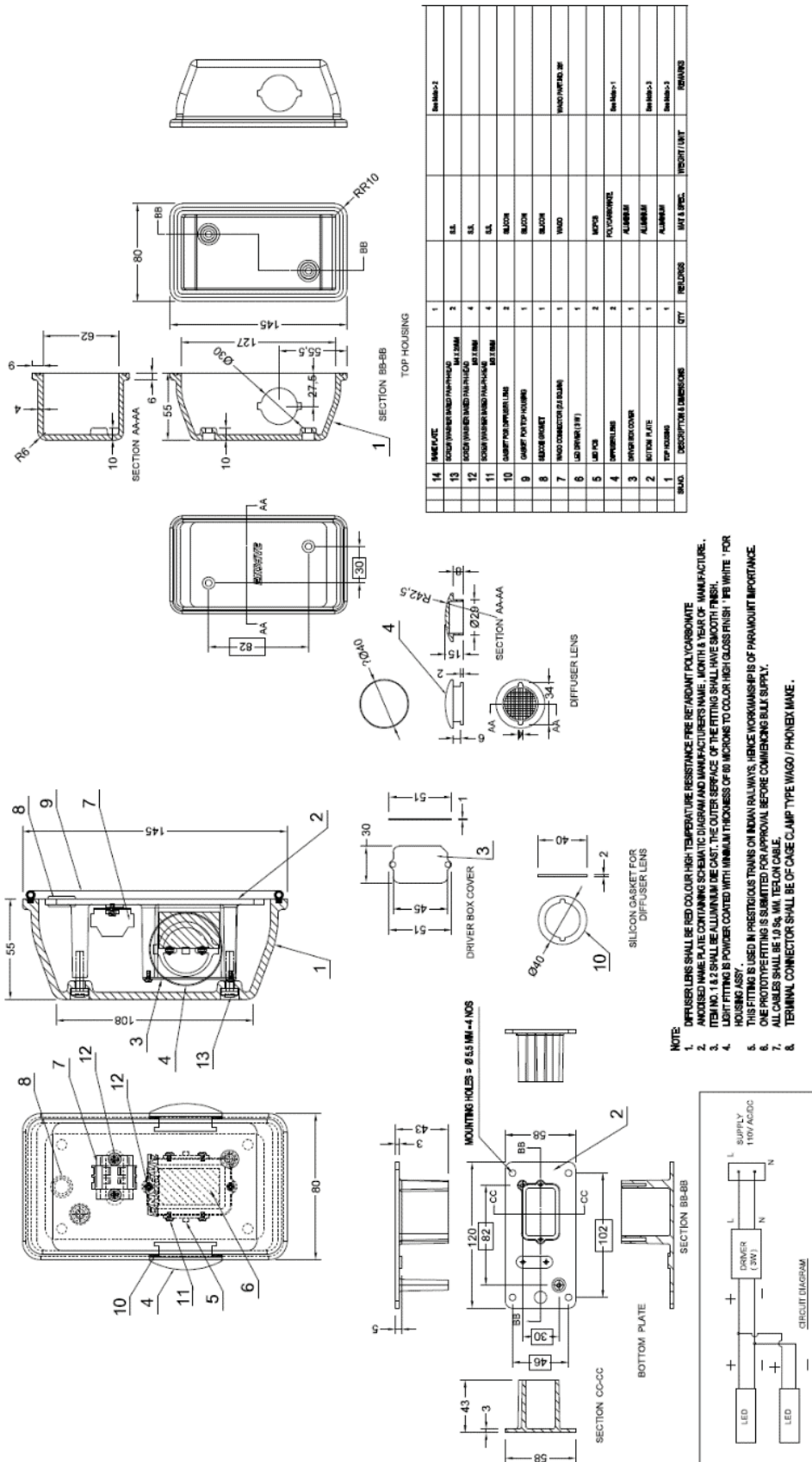

**36680000194**  
DRAWING NO.



**Technical Specification for  
Passenger Alarm system**

Doc. No.: PS4452988 - Part A, Rev. 00

**PROJECT**  
Vande Bharat 80  
rakes

Page 28 of 32

# Annexure - 3 Terminal Board Assembly

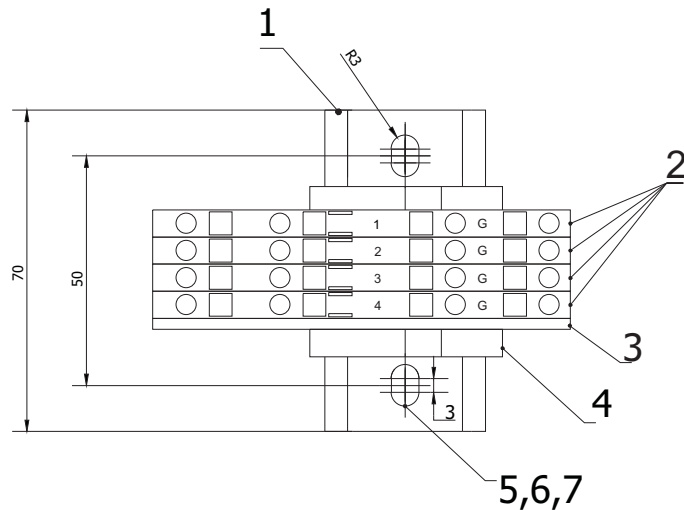

ITEM	DESCRIPTION & DIMENSIONS	QTY	REF.DRG.	MATL.SPEC.	WT/UNIT	REMARKS
1	CARRIER RAIL 7.5X35X70	1				TYPE 210-229 OF WAGO OR EQN ITEM OF PHOENIX,WEDMULLER &CONNECTWELL
2	4 CONDUCTOR TERMINAL BLOCK FRONT ENTRY SUITABLE FOR 0.08 TO 4 SQ.MM (GREY)	4				TYPE 281-652 OF WAGO OR EQN ITEM OF PHOENIX,WEDMULLER &CONNECTWELL
3	END PLATE	1				TYPE 281-334 OF WAGO OR EQN ITEM OF PHOENIX,WEDMULLER &CONNECTWELL
4	END STOP	2				TYPE 249-118 OF WAGO OR EQN ITEM OF PHOENIX,WEDMULLER &CONNECTWELL
5	SPRING WASHER B5	2	IS:3063-94	IS:1367(P-14) 84 A2 70		STAINLESS STEEL
6	PLAIN WASHER 5.5	2	IS:2016-67 TAB-2,TYPE-A	AISI-304		STAINLESS STEEL
7	CH. HD. SCREW M5X16	2	IS:1366(LATEST)	IS:1367(P-14) 84 A2 70		STAINLESS STEEL

NOTE: AS PER ICF DRAWING EMU2/TC/AC-7-6-006

TYPE OF PRODUCT OR NAME OF CUSTOMER/PROJECT		INDIAN RAILWAY'S			
BHARAT HEAVY ELECTRICALS LIMITED. ELECTRONICS DIVISION, BANGALORE	DRN	NAME	SIGN.	DATE	No. OF VAR
	CKD	PIYUSH		08.11.21	
	APPD	J SHUKLA		08.11.21	
		V DEVANAND		08.11.21	
DEPT. TE	FOR UNSPECIFIED-TOLERANCES REFER ED 0230499	SCALE WEIGHT(Kg)		REF. TO ASSY. DRG.	ITEM NO.
CODE 445					No. OF
DRAWING UPDATED		TITLE		DRAWING NO.	
		TERMINAL BOARD ASSEMBLY FOR PAIL		36680000194	
		SHEET NO. 01		NO. OF SHEETS 01	
				REV. 01	

REV.	DATE	ALTERED CHECKED	REV.	DATE	ALTERED CHECKED	REV.	DATE	ALTERED CHECKED	NITHISH ISHKUMAR
		APPROVED			APPROVED	01	17/12/22	APPROVED	J SHUKLA

It must not be used directly or indirectly in any way detrimental to the interest of the Company.  
 The information on this document is the property of Bharat Heavy Electricals Limited.  
 COPYRIGHT AND CONFIDENTIAL

REF. DRG. NO.

SIGN & DATE

INVENTORY NO.

Annexure-4 - LED-based alarm indicator

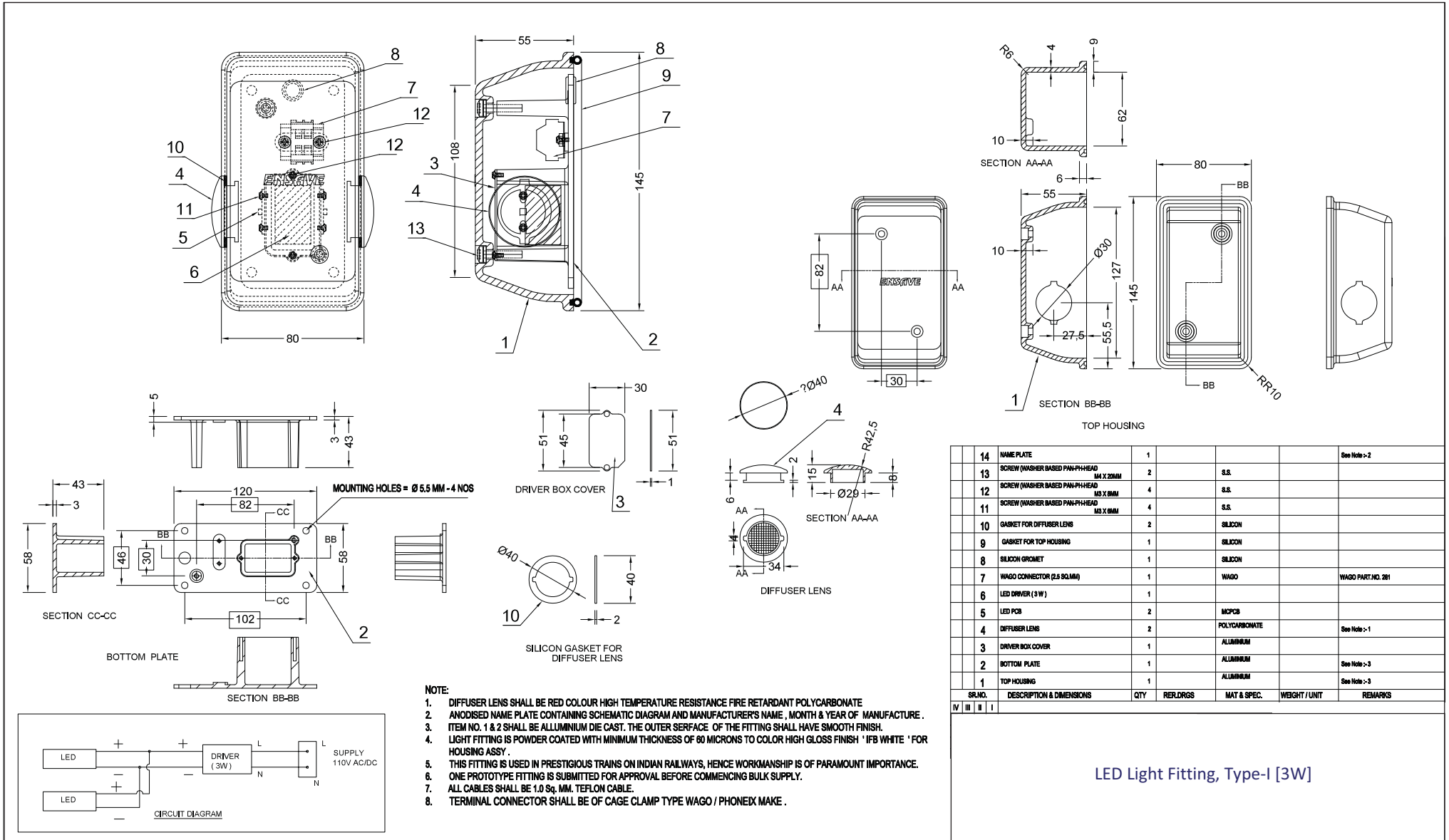

SR.NO.	DESCRIPTION & DIMENSIONS	QTY	RELRDRGS	MAT & SPEC.	WEIGHT / UNIT	REMARKS
14	NAME PLATE	1				See Note -2
13	SCREW (WASHER BASED PAN-PI-HEAD) M4 X 20MM	2		S.S.		
12	SCREW (WASHER BASED PAN-PI-HEAD) M3 X 8MM	4		S.S.		
11	SCREW (WASHER BASED PAN-PI-HEAD) M3 X 8MM	4		S.S.		
10	GASKET FOR DIFFUSER LENS	2		SILICON		
9	GASKET FOR TOP HOUSING	1		SILICON		
8	SILICON GROMMET	1		SILICON		
7	WAGO CONNECTOR (2.5 SQ/MM)	1		WAGO		WAGO PART.NO. 281
6	LED DRIVER (3 W)	1				
5	LED PCB	2		MCPCB		
4	DIFFUSER LENS	2		POLYCARBONATE		See Note -1
3	DRIVER BOX COVER	1		ALUMINIUM		
2	BOTTOM PLATE	1		ALUMINIUM		See Note -3
1	TOP HOUSING	1		ALUMINIUM		See Note -3

LED Light Fitting, Type-I [3W]

## Revision History

Rev No.	Date	Description/Update

# Pro forma for Performance Certificate

**Name of firm**

\_\_\_\_\_

TO WHOMSOEVER IT MAY CONCERN

Sub: Confirmation letter for service performance

Dear Sir,

We hereby confirm that We ..... have manufactured \_\_\_\_\_ number of sets of .....(Name of Equipment with Model No.) for 3 Phase IGBT based EMUs/MEMUs/Metros/trainsets/LOCOs.

We further confirm that ..... number of sets of .....(Name of Equipment with Model No.) for 3 Phase IGBT based EMUs/MEMUs/Metros/trainsets/Locos are in satisfactory operation for railway rolling stock application.

Pro forma for performance statement confirming above is also attached.

Yours faithfully

**For**

(Name of Firm)



**Checklist - Documents to be submitted by Bidder**

Sl. No.	Particulars	Acceptable documentation	Submitted with Tender	Document/s submitted by bidder	Remarks by Bidder
1	PQC qualification documentation	<ul style="list-style-type: none"> <li>RDSO/Indian Railways approval for Indian bidders</li> <li>Relevant PO copies</li> <li>Performance statements/certificate</li> </ul>	YES / NO		
2	Type test reports & protocol	<ul style="list-style-type: none"> <li>Recent type test reports from NABL-accredited laboratory and/or protocol for Indian bidders</li> <li>Recent type test reports from international accreditation agencies for international bidders and/or protocol</li> </ul>	YES / NO		
3	Routine test protocol	<ul style="list-style-type: none"> <li>Routine test protocol</li> </ul>	YES / NO		
4	QAP [Quality Action Plan]	<ul style="list-style-type: none"> <li>QAP [Quality Action Plan]</li> </ul>	YES / NO		
5	Clause-by-clause compliance - duly signed & stamped	<ul style="list-style-type: none"> <li>Signed &amp; stamped copy of complete specification</li> <li>Bidder's document tabling each specification clause and indicating the compliance against each clause</li> </ul>	YES / NO		
6	No deviation format - duly signed & stamped	<ul style="list-style-type: none"> <li>No deviation format, duly filled-in &amp; signed/stamped</li> </ul>	YES / NO		
7	Drawings & datasheets if applicable	<ul style="list-style-type: none"> <li>Drawing with all required data &amp; BoM</li> <li>Datasheet with all required parameters mentioned &amp; BoM</li> <li>Catalogue for standard product with all technical &amp; dimensional details mentioned</li> </ul>	YES / NO		
8	HL3 compliance	<ul style="list-style-type: none"> <li>Certificate from NABL approved lab or any International accreditation agency</li> </ul>	YES / NO		
9	Bill of Materials	<ul style="list-style-type: none"> <li>Unpriced copy of price format indicating "Quoted" against each line item</li> </ul>	YES / NO		
10	Spares for 35 years' maintenance requirement	<ul style="list-style-type: none"> <li>Preventive &amp; Corrective Maintenance Schedule with list of spares, in line with Chapter-5 of Technical Specification.</li> <li>Unpriced list of above spares with yearly consumption including replacements.</li> </ul>	YES / NO		
11	Checklist	<ul style="list-style-type: none"> <li>This checklist duly filled-in</li> </ul>	YES / NO		
12	Contact details for correspondence	<ul style="list-style-type: none"> <li>Email &amp; contact details of representative to contact for technical &amp; commercial queries</li> </ul>	YES / NO		
13	Authorization for bid signing	<ul style="list-style-type: none"> <li>Notarized/suitable valued bond paper stating authorization for bid signing</li> </ul>	YES / NO		
14	Formats in tech spec	<ul style="list-style-type: none"> <li>All formats to be filled which are part of the technical documentation .</li> </ul>	YES / NO		
15	RAMS Documentation	<ul style="list-style-type: none"> <li>Sample documents on RAMS compliance (as applicable) as per Chapter-4 of Technical Specification.</li> </ul>	YES / NO		

**Note to bidder -**

1	Bidder shall necessarily fill this checklist and upload it as a part of the documentation towards this tender. Incomplete documentation may make your offer liable for rejection
2	Bidder shall upload the documents in a logical sequence & include a table of content clearly indicating the page numbers
3	This list is not exhaustive & BHEL may ask for additional documentation from bidders in the course of evaluation of the offers

	<b>Vande Bharat Project</b>
	<b>RAMS TEMPLATES</b>
	<b>CONTENTS</b>
<b>1</b>	<b>Breakdown + Inherent Failure Reliability Prediction</b>
<b>2</b>	<b>Critical failures analysis</b>
<b>3</b>	<b>Failure Mode Effects and Criticality Analysis (FMECA)</b>
<b>4</b>	<b>System/Sub-Systems Hazard Analysis (SHA)</b>
<b>5</b>	<b>Hazard Log + SIL</b>
	<b>Note</b> All table are in accordance to the EN 50126-1-2-3 used as guideline. Refer to above standard for definition and meaning of contents. Minor differences may exist due to application of specific requirement from Railway Administration or final User

# Breakdown + Inherent Failure Reliability Prediction

Project:		Document No/Rev:	
System:	System Supplier:	Issue date:	
Sub-System:			
Drawing no:			

RAMS code				Equipment /System Breakdown	Part number	Data Input	DTC	MC	TC	NDTC	λ unit. BASIC (FPMH)	Duty Cycle %	λ Effett. BASIC (FPMH)	λ Train Level (FPMH)	λ Train Level LEVEL 1 (FPMH) ( 16 CarTrain)	λ Train Level LEVEL 2 (FPMH) ( Sub System)
				Equipment /System												
				<b>Sum of Subsystems</b>												
1	1			<b>Sub System 1</b>												<b>0.00</b>
1	1	1		Item 1												
1	1	2		Item 2												
1	1	3		Item (n)												
1	2			<b>Sub System 2</b>												<b>0.00</b>
1	2	1		Item 1												
1	2	2		Item 2												
1	2	3		Item (n)												
1	3			<b>Sub System (n)</b>												<b>0.00</b>
1	3	1		Item 1												
1	3	2		Item 2												
1	3	3		Item (n)												
				<b>66</b>												



## Failure Mode Effects and Criticality Analysis (FMECA)

Project:														Document No/Rev:				
System:														System Supplier:		Issue date:		
Sub-System:																		
Drawing no:																		
Position No	Part/LRU Code	Description	P/N	Coach type	Function	Phase	Failure mode		Cause of Failure Mode	Failure rate (FPMH)	Failure effect			Criticality		Failure identification /detection	Preventive and compensating measures	Remarks
							Fail. Mode index	Failure Mode			Local	System	Train	Service	Safety			

## System/Sub-Systems Hazard Analysis (SHA)

:		Document No/Rev:
:	System Supplier:	Issue date:
stem:		
g no:		

Main System ID	Hazard Category	Hazard description (general)	Hazard Identification (detailed)	Hazard description (detailed)	Sequential Numbering	Phase / Operation mode	System / Sub-System / Component	Causes	Consequence Potential accident/ damage	Severity Level	Probability	Risk Category	Preventive/compensating actions (Design, Maintenance, Operational Safeguards)	Target risk category	Remarks / Documents reference	Comments
Code that univocally identifies the system object of SHA	Numbering for each hazard of the corresponding "hazard type category"	Hazard category in according with Hazard List	Numbering for each hazard of the corresponding "hazard type"	Specific description of the generic hazard	Progressive number associated to previous column	<ul style="list-style-type: none"> <li>- Running / Normal operation</li> <li>- Running / Degraded operation</li> <li>- Running / Multiple operation</li> <li>- Running / Emergency operation</li> <li>- Standstill / Parking</li> <li>- Standstill / Stabling</li> <li>- Standstill /Driver cab change</li> <li>- Depot / Manoeuvre</li> <li>- Depot / Maintenance</li> </ul>	System/ subsystem /component from which the hazard originates	Description of the cause that originate the corresponding hazard	Description of the consequences that could occur in case of the corresponding hazard. The subject of the consequences shall be identified.	Severity level category	Estimated Frequency of Hazard	Risk category and acceptance criteria	The preventive and mitigation measures identified in order to reach the Target risk Objective. All the useful Design, Maintenance, Operational safeguards shall be taken into account, and where available, a reference to applicable standards or regulation shall be reported.	Desired risk category and acceptance criteria	Reference to drawings or specification or documents	Any useful comments for a better understanding. For example it shall be highlighted if an hazard needs to be exported to the vehicle builder / train operator



## Corrective Maintenance Analysis

<b>Doc. No</b>		<b>Rev No.</b>	<b>00</b>
<b>Date:</b>			
<b>Project</b>	<b>Vande Bharat Project</b>		
<b>Equipment:</b>			
<b>Supplier:</b>			
<b>Compiled by:</b>			

			REMARKS
Manpower cost		<b>Rs/hrs</b>	
Yearly distance run	<b>3,50,000</b>	<b>km</b>	
LCC period	<b>35</b>	<b>Years</b>	
Fleet (nr. of trains)	<b>80</b>	<b>Trains</b>	



## Preventive Maintenance Analysis

<b>Doc. No</b>		<b>Rev No.</b>	
<b>Date:</b>			
<b>Project</b>	<b>Vande Bharat Project</b>		
<b>Equipment:</b>			
<b>Supplier:</b>			
<b>Compiled by:</b>			

			REMARKS
Conversion speed		km/hrs	
Manpower cost		Rs/hrs	
Yearly distance run	<b>3,50,000</b>	km	
Running days per year		days	
LCC considered period	<b>35</b>	years	
Basic maintenance frequency		km	
Distance covered in the considered period	<b>1,22,50,000</b>	km	
Train-sets number in the fleet	<b>80</b>	Trains	



## NO DEVIATION CERTIFICATE

**Tender Enquiry:**

**Date:**

**Bidders Ref. No.:**

With reference to the Bid submitted against the aforesaid tender, we hereby confirm that we comply and agreeing with all terms, conditions and specifications/clauses of the Bidding document issued and the same has been taken into consideration while making our Techno-Commercial Bid.

We hereby certify that there is “NO TECHNICAL DEVIATION” from the tender document mentioned above.

Signature of the Tenderer

Office Seal