



PREQUALIFICATION CRITERIA FOR
TRAIN SET (SLEEPER) 80 SETS PROJECT

PQC/ PES-TE/BOI-80
trainsets

Revision No. 00

Page 01 of 01

1.0 Pre-Qualification Criteria

1.1 The bidder should be a manufacturer/supplier of the product for Rolling stock application of Railways for 3 phase IGBT based Train sets/RRTS/Semi high speed trains/AC EMU/MEMU/Metros in India or any railway systems in the world.

1.2 For supplies made in India, bidder should be approved vendor of Indian Railways /Metro/RRTS.

OR

For supplies made to any railway systems in the world, bidder shall provide approval, authenticated by country's recognized railway organization. Acceptance of such approvals will be at BHEL's discretion.

1.3 The product should have valid type test certificates complying to relevant latest IEC and other standards mentioned in the Reference Technical Specification for rolling stock application on the date of submission of the tender. The bidder shall fully comply with the type and routine test & inspection clause of the technical specification. The bidder shall conduct/repeat type tests either partially or fully **for the offered product** without any price implication to BHEL. Decision to conduct type test shall be at BHEL's discretion.

OR

The bidder shall provide valid type test certificate/reports complying to relevant latest IEC and other standards for similar product supplied as per clause 1.1. Acceptance of such type test certificate/reports will be at BHEL's discretion. In such case, bidder will be considered for technical evaluation. The bidder shall conduct type tests fully **for the offered product**, without any price implication to BHEL.

1.4 Those bidder(s) who are registered with BHEL/ BHEL's customer (as the case may be) shall be considered for technical evaluation, subject to meeting above PQC clauses.

Bidders who are not registered with BHEL/BHEL's customer (as the case may be) can also quote in the tender. However, their credentials will be assessed for consideration in the tender, before price bid opening, subject to meeting above PQC clauses.

2.0 Documents to be submitted

All the relevant documents proof for points referred in 1.0 shall be submitted along with the tender.

Rev. 00

Approved: Anjul

Prepared

Narasimha Shenoy

Checked

C David

Date:

19.01.2024

COPYRIGHT AND CONFIDENTIAL
The information on this document is the property of BHARAT HEAVY ELECTRICALS LIMITED.
It must not be used directly or indirectly in anyway detrimental to the interest of the company.

Bharat Heavy Electricals Limited Electronics Division, Mysore Road, Bengaluru

Purchase Specification no - PS4452961

Item - Driver Desk

Vendor name - M/s

Price Format for Vande Bharat Train Sets

Sl. No.	Material Code	Item Description	Applicability (Yes/No)	Qty [A1]	UOM	Unit Rate [A2]	Cost per Rake [A3=A1*A2]	Total No. of Rakes [A4]	Total Qty for Supply [A1*A4]	Total Cost [A5=A3*A4]	Remarks
1				Per rake		in INR	in INR	in Nos.	Nos. / Set	in INR	
1.1	PR248000028	Basic Price	Yes	2	Set		0	32	64	0	
1.2		Freight & Insurance	Yes		Set		0		64	0	
Total of sl no 1											
2											
2.1		AOH (1.5 Yrs) Spare Kit with consumables considering 6 years' consumption	No	X	X	X	X	X	X	X	
2.2		IOH (3 Yrs) Spare Kit with consumables considering 6 years' consumption	No	X	X	X	X	X	X	X	
2.3		POH (6 Yrs) Spare Kit with consumables considering 6 years' consumption	No	X	X	X	X	X	X	X	
2.4		Special Tool Kit (One time)	No	X	X	X	X	X	X	X	
2.5		AMC for 4 (four) years post warranty period	No	X	X	X	X	X	X	X	
2.6		Spares for annual maintenance (for one year)	No	X	X	X	X	X	X	X	
Total of sl no 2											
3											
3.1		Commissioning & Supervision of Erection of Prototype Rake	Yes	2	Nos.			2	4		
3.2		Commissioning & Supervision of Erection of All Rakes (Including Prototype)	No	X	X	X	X	X	X	X	
Total of sl no 3											

Note -

1. Any item required for functional integrity and commissioning of the item/system and not considered above shall be provided by the bidder without any cost implication to BHEL.

2. Bidder shall quote as per the quantities mentioned in this table only. Quantities mentioned in the specification are for reference purpose.

3. Tender evaluation shall be done on the total of sl. no. 1, 2 & 3. Purchase Order for Items in sl. no. 2 may be placed separately.

4. Each rake consists of 16 coaches.

Checklist - Documents to be submitted by Bidder

Sl. No.	Particulars	Acceptable documentation	Submitted with Tender	Document/s submitted by bidder	Remarks by Bidder
1	PQC qualification documentation	<ul style="list-style-type: none"> RDSO/Indian Railways approval for Indian bidders Relevant PO copies Performance statements/certificate 	YES / NO		
2	Type test reports & protocol	<ul style="list-style-type: none"> Recent type test reports from NABL-accredited laboratory and/or protocol for Indian bidders Recent type test reports from international accreditation agencies for international bidders and/or protocol 	YES / NO		
3	Routine test protocol	<ul style="list-style-type: none"> Routine test protocol 	YES / NO		
4	QAP [Quality Action Plan]	<ul style="list-style-type: none"> QAP [Quality Action Plan] 	YES / NO		
5	Clause-by-clause compliance - duly signed & stamped	<ul style="list-style-type: none"> Signed & stamped copy of complete specification Bidder's document tabling each specification clause and indicating the compliance against each clause 	YES / NO		
6	No deviation format - duly signed & stamped	<ul style="list-style-type: none"> No deviation format, duly filled-in & signed/stamped 	YES / NO		
7	Drawings & datasheets if applicable	<ul style="list-style-type: none"> Drawing with all required data & BoM Datasheet with all required parameters mentioned & BoM Catalogue for standard product with all technical & dimensional details mentioned 	YES / NO		
8	HL3 compliance	<ul style="list-style-type: none"> Certificate from NABL approved lab or any International accreditation agency 	YES / NO		
9	Bill of Materials	<ul style="list-style-type: none"> Unpriced copy of price format indicating "Quoted" against each line item 	YES / NO		
10	Spares for 35 years' maintenance requirement	<ul style="list-style-type: none"> Preventive & Corrective Maintenance Schedule with list of spares, in line with Chapter-5 of Technical Specification. Unpriced list of above spares with yearly consumption including replacements. 	YES / NO		
11	Checklist	<ul style="list-style-type: none"> This checklist duly filled-in 	YES / NO		
12	Contact details for correspondence	<ul style="list-style-type: none"> Email & contact details of representative to contact for technical & commercial queries 	YES / NO		
13	Authorization for bid signing	<ul style="list-style-type: none"> Notarized/suitable valued bond paper stating authorization for bid signing 	YES / NO		
14	Formats in tech spec	<ul style="list-style-type: none"> All formats to be filled which are part of the technical documentation . 	YES / NO		
15	RAMS Documentation	<ul style="list-style-type: none"> Sample documents on RAMS compliance (as applicable) as per Chapter-4 of Technical Specification. 	YES / NO		

Note to bidder -

1	Bidder shall necessarily fill this checklist and upload it as a part of the documentation towards this tender. Incomplete documentation may make your offer liable for rejection
2	Bidder shall upload the documents in a logical sequence & include a table of content clearly indicating the page numbers
3	This list is not exhaustive & BHEL may ask for additional documentation from bidders in the course of evaluation of the offers

	Vande Bharat Project
	RAMS TEMPLATES
	CONTENTS
1	Breakdown + Inherent Failure Reliability Prediction
2	Critical failures analysis
3	Failure Mode Effects and Criticality Analysis (FMECA)
4	System/Sub-Systems Hazard Analysis (SHA)
5	Hazard Log + SIL
	Note All table are in accordance to the EN 50126-1-2-3 used as guideline. Refer to above standard for definition and meaning of contents. Minor differences may exist due to application of specific requirement from Railway Administration or final User

Breakdown + Inherent Failure Reliability Prediction

Project:		Document No/Rev:	
System:	System Supplier:	Issue date:	
Sub-System:			
Drawing no:			

RAMS code				Equipment /System Breakdown	Part number	Data Input	DTC	MC	TC	NDTC	λ unit. BASIC (FPMH)	Duty Cycle %	λ Effett. BASIC (FPMH)	λ Train Level (FPMH)	λ Train Level LEVEL 1 (FPMH) (16 CarTrain)	λ Train Level LEVEL 2 (FPMH) (Sub System)
				Equipment /System												
				Sum of Subsystems												
1	1			Sub System 1												0.00
1	1	1		Item 1												
1	1	2		Item 2												
1	1	3		Item (n)												
1	2			Sub System 2												0.00
1	2	1		Item 1												
1	2	2		Item 2												
1	2	3		Item (n)												
1	3			Sub System (n)												0.00
1	3	1		Item 1												
1	3	2		Item 2												
1	3	3		Item (n)												
				66												

Failure Mode Effects and Criticality Analysis (FMECA)

Project:														Document No/Rev:				
System:														System Supplier:		Issue date:		
Sub-System:																		
Drawing no:																		
Position No	Part/LRU Code	Description	P/N	Coach type	Function	Phase	Failure mode		Cause of Failure Mode	Failure rate (FPMH)	Failure effect			Criticality		Failure identification /detection	Preventive and compensating measures	Remarks
							Fail. Mode index	Failure Mode			Local	System	Train	Service	Safety			

System/Sub-Systems Hazard Analysis (SHA)

:		Document No/Rev:
:	System Supplier:	Issue date:
stem:		
g no:		

Main System ID	Hazard Category	Hazard description (general)	Hazard Identification (detailed)	Hazard description (detailed)	Sequential Numbering	Phase / Operation mode	System / Sub-System / Component	Causes	Consequence Potential accident/ damage	Severity Level	Probability	Risk Category	Preventive/compensating actions (Design, Maintenance, Operational Safeguards)	Target risk category	Remarks / Documents reference	Comments
Code that univocally identifies the system object of SHA	Numbering for each hazard of the corresponding "hazard type category"	Hazard category in accoding with Hazard List	Numbering for each hazard of the corresponding "hazard type"	Specific description of the generic hazard	Progressive number associated to previous column	<ul style="list-style-type: none"> - Running / Normal operation - Running / Degraded operation - Running / Multiple operation - Running / Emergency operation - Standstill / Parking - Standstill / Stabling - Standstill /Driver cab change - Depot / Manoeuvre - Depot / Maintenance 	System/ subsystem /component from which the hazard originates	Description of the cause that originate the corresponding hazard	Description of the consequences that could occur in case of the corresponding hazard. The subject of the consequences shall be identified.	Severity level category	Estimated Frequency of Hazard	Risk category and acceptance criteria	The preventive and mitigation measures identified in order to reach the Target risk Objective.All the useful Design, Maintenance, Operational safeguards shall be taken into account, and where available, a reference to applicable standards or regulation shall be reported.	Desired risk category and acceptance criteria	Reference to drawings or specification or documents	Any useful comments for a better understanding. For example it shall be highlighted If an hazard needs to be exported to the vehicle builder / train operator

Corrective Maintenance Analysis

Doc. No		Rev No.	00
Date:			
Project	Vande Bharat Project		
Equipment:			
Supplier:			
Compiled by:			

			REMARKS
Manpower cost		Rs/hrs	
Yearly distance run	3,50,000	km	
LCC period	35	Years	
Fleet (nr. of trains)	80	Trains	

Preventive Maintenance Analysis

Doc. No		Rev No.	
Date:			
Project	Vande Bharat Project		
Equipment:			
Supplier:			
Compiled by:			

			REMARKS
Conversion speed		km/hrs	
Manpower cost		Rs/hrs	
Yearly distance run	3,50,000	km	
Running days per year		days	
LCC considered period	35	years	
Basic maintenance frequency		km	
Distance covered in the considered period	1,22,50,000	km	
Train-sets number in the fleet	80	Trains	



BHARAT HEAVY ELECTRICALS LIMITED
ELECTRONICS DIVISION
Mysore Road, Bangalore

Doc. No : PS4452961

Rev. No : 00

Page : 1 of 3

**CUSTOMER/
USER**

BHEL/INDIAN RAILWAYS

PROJECT

MANUFACTURING CUM MAINTENANCE OF VANDE
BHARAT TRAINSETS

COPYRIGHT AND CONFIDENTIALITY
 The information on this document is the property of
BHARAT HEAVY ELECTRICALS LTD.
 It must not be used directly or indirectly in anyway detrimental to the
 interest of the company

Purchase Specification for Driver Desk

**Rev
No.**

Date

Altered

Checked

Approved

Revision Details

Issued by:
Traction Engg. Dept.,
BHEL-EDN

Approved

Anjul

Prepared

Narasimha Shenoy

Checked

David J

Date

27.12.2023

	Purchase Specification for APC Receiver	Project – Vande Bharat – 80 sets
	Doc. No.: PS4452961	

1.1 Technical Specification

1.1.1 For the technical requirement, bidder to refer to PS4452961 - Part A

2.1 Bill of Quantities

2.1.1 Bill of Materials in the technical specification (Part A) is for information only.

Bidder to consider & quote for the items as per the quantity mentioned in the RFQ

3.1 Packing Instructions

3.1.1 Successful bidder to mandatorily follow the packing instructions given in Part A

3.1.2 Stack-ability of the packaged boxes & storage worthiness/durability to be ensured

3.1.3 Successful bidder shall ensure that set-wise Packing List be pasted on each Box
(Typical format enclosed with this document)



Purchase Specification for
APC Receiver

Project – Vande
Bharat – 80 sets

Doc. No.: PS4452961

Rev. No. 00

Set wise Packing List to be pasted on each Box

Supplier shall furnish the packing list as per the format given below:

BHEL PO No.	
BHEL Material Code	
Material Description	
Quantity (Set)	
Box No (per set)	

Bill of Materials (Supplier shall list down all the items including loose items and respective quantities):

Main Item:

Sl. No.	Item description	Quantity per Set	Total Sets packed in the Box (applicable in case of multiple sets in one Box)

Loose Items (if any):

Sl. No.	Item description	Quantity per Set	Total Sets packed in the Box (applicable in case of multiple sets in one Box)

Supplier details:

Notes for suppliers:

- 1) Suppliers shall pack items, set wise in one box. In case of multiple boxes for one set, supplier shall identify box numbers (Set 1/ Box1, Set 1/ Box2 etc.)
- 2) Packing list shall be pasted on each box, as per actual contents inside the box. This list will be in addition to the supplier's standard packing list.
- 3) Box wise Packing list shall be shared with BHEL MM and same will be mandatory for dispatch clearance.



BHARAT HEAVY ELECTRICALS LIMITED
ELECTRONICS DIVISION
 Mysore Road, Bangalore

DOC. NO: PS4452961-part A
REV. NO: 00
Page 1 of 61



COPYRIGHT AND CONFIDENTIALITY
 The information on this document is the property of
BHARAT HEAVY ELECTRICALS LTD.
 It must not be used directly or indirectly in anyway detrimental to the interest of the company

CUSTOMER/ USER	BHEL/INDIAN RAILWAYS
PROJECT	Manufacturing cum Maintenance of Vande Bharat Trainsets

TECHNICAL SPECIFICATION

**DRIVER DESK WITH
ACCESSORIES**

Rev No.	Date	Altered	Checked	Approved	Revision Details

Issued by: Traction Engg. Dept., BHEL-EDN	APPROVED  S P Singh		
	PREPARED  Dayananda Kumar P	CHECKED  Prafful K Lakra	DATE 23.12.2023

	TECHNICAL SPECIFICATION FOR DRIVER DESK WITH ASCESSORIES	PROJECT- ICF Trainsets
	DOC. No.: PS4452961-part A, REV No. 00	

Table of Contents:

SECTION – 1	4
SCOPE, QUANTITIES & ELIGIBILITY.....	4
1.1 SCOPE	4
1.2 BILL OF MATERIAL:	4
1.3 ELIGIBILITY CRITERIA.....	6
1.4 CLAUSE BY CLAUSE COMPLIANCE	6
1.5 REFERENCE SPECIFICATIONS	6
SECTION – 2	7
TECHNICAL SPECIFICATION	7
2.1 TECHNICAL SPECIFICATION OF DRIVER DESK WITH ACCESSORIES.....	7
2.2 DRIVER DESK WITH ACCESSORIES	9
2.3 ACCESSORIES	15
2.4 EQUIPMENT TESTING	16
2.5 DESIGN REQUIREMENTS TO BE PROVIDED BY SUPPLIER	17
SECTION – 3	18
PROJECT DETAILS AND GENERAL SPECIFICATIONS.....	18
3.1 GENERAL.....	18
3.2 INSTRUCTION TO BIDDERS	18
3.3 GENERAL DESIGN REQUIREMENTS.....	18
3.4 INGRESS PROTECTION	21
3.5 AMBIENT CONDITIONS / OPERATING CONDITIONS.....	22
3.6 STANDARDS	23
3.7 ENGINEERING DATA	24
3.8 MARKING OF EQUIPMENT & RATING PLATE.....	25
3.9 INFRINGEMENT OF PATENT RIGHTS.....	25
3.10 DOCUMENT SUBMISSIONS.....	25
3.11 QUALITY ASSURANCE PROGRAMME	26
3.12 QUALITY ASSURANCE DOCUMENTS	27
3.13 TYPE AND ROUTINE TESTING & INSPECTION	27
3.14 MATERIALS AND WORKMANSHIP	28
3.15 PACKING, STORAGE AND HANDLING INSTRUCTIONS	28
3.16 FIRE PREVENTION	29
SECTION – 4	30
RELIABILITY, AVAILABILITY, MAINTAINABILITY AND SAFETY (RAMS)	30
4.1 KEY PERFORMANCE INDICATORS	30
4.2 RELIABILITY AVAILABILITY MAINTAINABILITY AND SAFETY (RAMS).....	30
4.3 RAMS DOCUMENTATION	31



**TECHNICAL SPECIFICATION FOR
DRIVER DESK WITH ASCCESSORIES**

DOC. No.: PS4452961-part A, REV No. 00

**PROJECT- ICF
Trainsets**

4.4 SERVICE LIFE OF EQUIPMENT/SYSTEM.....	31
4.5 TRAIN MAINTENANCE SCHEDULE (TENTATIVE)	33
SECTION -5.....	34
SPARES AND CONSUMABLES FOR MAINTENANCE.....	34
5.1 SPARES AND CONSUMABLES.....	34
5.2 SCHEDULED MAINTENANCE.....	34
5.3 UNSCHEDULED MAINTENANCE.....	35
5.4 EPIDEMIC DEFECT WARRANTY	35
5.5 OPERATION AND MAINTENANCE MANUAL	35
5.6 OBSOLESCENCE MANAGEMENT.....	37
ANNEXURE-I(A)	38
BOM - TENTATIVE LIST OF COMPONENTS / ITEMS	38
ANNEXURE-I(B)	43
BOM - SPARE ITEMS LIST	43
ANNEXURE-II.....	44
TENTATIVE LAYOUT ARRANGEMENT & DESK PANEL DETAILS.....	44
DRIVER SEAT REFERENCE GA DRAWING	57
ANNEXURE-IV.....	58
SUN VISOR REFERENCE DRAWING.....	58
PERFORMA FOR PERFORMANCE CERTIFICATE.....	59
PERFORMA FOR PERFORMANCE STATEMENT	60
REVISION HISTORY	61

	TECHNICAL SPECIFICATION FOR DRIVER DESK WITH ASCCESSORIES	PROJECT- ICF Trainsets
	DOC. No.: PS4452961-part A, REV No. 00	

SECTION – 1

SCOPE, QUANTITIES & ELIGIBILITY

1.1 SCOPE

This technical specification covers the requirements of design, manufacture, testing at works, packing and dispatch of Pre-Wired Driver's Desk with Accessories along with Male & Female connectors and spares.

The equipment is required for the following project.

Name of the customer: BHEL/INDIAN RAILWAYS

Name of the Project: Manufacturing cum Maintenance of Vande Bharat Trainsets

The scope shall also include the followings:

- a. The supply of complete documentation for approval of design, relevant drawings and calculations to the satisfaction of purchaser and RDSO/ICF/Nominated Agency and support documentation associated with the operation and maintenance of the equipment supplied.
- b. The supplier shall submit list of equipment and facilities required for maintenance and overhaul of equipment offered.
- c. The design has to be approved by RDSO/ICF/IR/nominated agency.

1.2 BILL OF MATERIAL:

Sl. No.	Description	Quantity (per 16 car Train)	Remarks
1.	Driver Desk with Accessories (Pre-wired with Prefabricated FRP Panel/Console)	2 Set	Quantity for each set as mentioned in Table (1) below
2.	Complete Accessories required for mounting and electrical connections with complete mating connectors	As required	Complete list shall be provided by vendor for approval of BHEL/RDSO/ICF/nominated agency. Mounting details to be finalized during design stage in consultation with ICF/RDSO/nominated agency.

	TECHNICAL SPECIFICATION FOR DRIVER DESK WITH ASCCESSORIES	PROJECT- ICF Trainsets
	DOC. No.: PS4452961-part A, REV No. 00	

TABLE (1)

EACH DRIVER'S DESK SET CONSISTING OF FOLLOWING ITEMS:

SL.NO.	ITEM DESCRIPTION	QTY. PER SET	REMARKS
A. DRIVER DESK:			
1)	DRIVERS DESK (Pre-wired & with Prefabricated FRP Panel/Console)	1 No.	Item no. 2 to 6 to be supplied fitted on driver desk
2)	Control switches, indicators, buzzers	As per Clause 2.2.2	
3)	Terminal Boards & Diode TBs	As per Clause 2.2.3	
4)	Connectors	As per Clause 2.2.4	
5)	Time Table clip	2 Nos.	
6)	Electric hooter switch with magnet valve for horn	As per Clause 2.2.1 02 Nos.	
B. ACCESSORIES:			
7)	Driver Seat	1 No.	Item no. 7 to 9 to be supplied in loose separately packed.
8)	Guard Seat	1 No.	
9)	Sun visor	1 Set	
Other Accessories Required For Mounting and Electrical Connections		As required	Bottom anchoring bracket to be welded to coach

Note:

- For more details of each item mentioned above, please refer detailed description in Section 2 of this specification.
- The design and dimensions of the Mould and the frame shall be finalized in consultation with Indian Railways based on the design of Nose Cone of the coach builder. Driver desk should have anchoring and earthing location at appropriate position. All Electronics under the driver's desk shall be mounted on a mild steel structural frame with IP54 protection. Detachable hinge type door is to be provided.
- Control Switches and Indicators: The desk panel components (switches, indicators etc.) of M/s EAO make or equivalent shall be used. The tentative quantity along with function has been mentioned in the Annexure-I (A). The Make, type, color, number of contact modules etc. for switches and indicators shall be finalized during detailed design stage with due concurrence of Indian Railways/nominated agency.
- Prototype driver desk as per the finalized GA/OGA drawing shall be supplied, fitted with components mentioned in this specification in pre-wired condition.

	TECHNICAL SPECIFICATION FOR DRIVER DESK WITH ASCCESSORIES	PROJECT- ICF Trainsets
	DOC. No.: PS4452961-part A, REV No. 00	

5. Suitable mounting and wiring correction as required in prototype rake at train manufacturer works shall be in the scope of supplier/vendor. Based on the feedback of prototype driver desk from ICF/User Railway/Train Manufacturer, further supply of driver desks incorporating the feedbacks for series supply shall be made by supplier/vendor and supplied without any commercial implication on BHEL.
6. Earthing of driver desk shall be done at 04 locations. Exact location of earthing points on desk shall be finalized during detailed design stage.
7. Supplier has to indicate the make and part number of Switches/indicators/push buttons/auxiliary contacts/ TB, etc. being offered against enquiry /tender along with technical offer.
8. The Driver's desk shall be ergonomically designed for convenience and to minimize fatigue of the Loco Pilot. Ergonomic and human engineering aspects of the desk design shall be compatible with Indian Anthropometric Dimensions. The visibility diagram shall be in accordance with UIC 651 and shall be submitted for BHEL review.
9. Supplier shall make available the Driver's desk mock-up at vendor works, with all original fittings planned intact, for review by the BHEL/IR/nominated agency. The mock-up shall demonstrate, together with all aesthetic design sessions supported by samples, 3D virtual views etc. The mock-up will be reviewed by a team of BHEL/IR nominated agency personnel and based on the review, the supplier shall carry out necessary modifications.

1.3 ELIGIBILITY CRITERIA

The Bidder should be a regular supplier to Indian Railway Projects and should have supplied the offered equipment for Indian Railways projects of 3 phase IGBT Based AC EMU/MEMU/ Metros/Trainsets/Locomotives operating in India.

1.4 CLAUSE BY CLAUSE COMPLIANCE

Vendor to submit clause by clause compliance to complete technical specification along with the technical bid.

1.5 REFERENCE SPECIFICATIONS

This purchase specification has the reference of Railway Specification No. ICF MD SPEC-398 Rev-01 dated: 05/11/2022.

	TECHNICAL SPECIFICATION FOR DRIVER DESK WITH ASCESSORIES	PROJECT- ICF Trainsets
	DOC. No.: PS4452961-part A, REV No. 00	

SECTION – 2

TECHNICAL SPECIFICATION

2.1 TECHNICAL SPECIFICATION OF DRIVER DESK WITH ACCESSORIES

1. Bidder shall design the complete pre-fabricated driver's desk consisting of all the necessary equipment in line with the UIC 651. The layout of the crew area and control system shall be ergonomically designed to allow crew to efficiently operate all controls for safe train operation either sitting or standing. All necessary controls and instrumentation shall be presented in a manner that shall aid the correct reflex action from the Driver in both normal and emergency situations. The driving position shall be on the left side of the Driving Cab and the brake handles shall be located on the left hand side of the Driver in the running direction. Their relative positions shall be similar to those available on IR's present Vande Bharat Trainset.
2. The cab shall be ergonomically designed for convenience and to minimize fatigue of the Driver. Ergonomic and human engineering aspects of the cab design shall be compatible with the range 5th percentile Indian adult female to 95th percentile Indian adult male. The visibility diagram shall be in accordance with UIC 651.
3. The driving cab shall include all the cab equipment e.g. combined master-cum-brake controller, instrument panel with back-lit instruments, gauges for pneumatic indications, control panels, driver's diagnostic display unit & driver's "log in" device, driver and guard adjustable seats etc., ergonomically designed driver' desk/console, pre-wired and terminated on a terminal board and multi-pin plugs/sockets for inter-equipment connections. Cab equipment shall also include pneumatic horns (on both sides of the desk), electric motor driven wind screen wipers (wiper should have wind screen washer & control as well), rolling blinds, sun-visors, tail light, safety related equipment like bell code system, flasher light control unit and speedometer-cum-recorder. This shall also include suitable 'bell code exchange' system between the cabs of the Train. Temperature and humidity indications shall be provided in both the cabs, may be part of air-conditioning.
4. All crew workstation/driving desk and cab area controls must be robust, of industrial quality and resist physical abuse and vandalism. Moulded FRP or better material suitable for such application must be used. The color scheme of interior shall be frozen at the time of design approval. FRP tests shall be done as per Railway specification MDTs-133, Rev. 05 (latest). In addition to this specification, fire properties as per existing RDSO specification of interior coach furnishing items shall be as under:

Name of Test	Specified Value	Test Method
Resistance to spread of flame	Class A	Appendix 11 of UIC 564-2 OR
Limiting oxygen index	Min 35	IS 13360 Part 6, Sec-19
Deterioration of visibility due to smoke	Class A	Appendix-15 of UIC 564-2 OR
Toxicity Index	<1	NCD-1409
Heat Release Rate (MARHE in kW/m ²) as specified in EN-45545-2	R1 (HL3)	ISO 5660-1: 50 kW/m ²

	TECHNICAL SPECIFICATION FOR DRIVER DESK WITH ASCCESSORIES	PROJECT- ICF Trainsets
	DOC. No.: PS4452961-part A, REV No. 00	

5. The top of the driver's control workstation must accommodate documents such as timetable or similar books without interfering with the operation of the controls.
6. The positioning of crew interface controls must be such that they are within the range of vision, touch and audibility requirements whilst the crew is in his/her normal operating positions under all operation conditions.
7. Equipment such as air pipes, conduits, ducts, cabling, terminals and connectors shall be hidden from the view and shall not interfere with the crew operations. The doors of such enclosures shall preferably be sliding with proper locking arrangements with ease of handling.
8. Each functional position and/or range must be clearly marked by embossed or engraved letters. The labeling used must be by agreement.
9. Provision for earthing shall be provided for all control units inside driver desk panel along with 4 sq mm (GNYE) wire with lugs at both ends and having length approx. 500 mm. Exact length shall be finalized during detailed design stage.
10. All fabricated parts and FRP top cover painting shall be RAL 7000 (squirrel grey semi glossy) Anthracite Grey semi glossy). All doors and detachable panels shall be powder coated with painting as per RAL 9005 (jet black texture). All doors shall be fabricated with SS 409M sheet 3 mm thick, grade No. BS EN10088-2. Color scheme is tentative and shall be finalized during detailed design stage.
11. Ergonomically designed driver's desk/console taking into account necessary traction controls, safety controls and passenger amenities items etc. shall be a part of the complete driver's cab. The design of the console shall also take into account the positioning of various pneumatic gauges (MR, BP, BC, PB etc.), brake controller, TPWS/TCAS equipment if any and any other equipment installed in the cab. Provision for placing the time-table along with clip arrangement shall also be made. Major functions control and their indications shall be provided on the desk.
12. The complete desk shall be supplied pre-wired and terminated on the terminal board and multi-pin plugs/sockets for inter equipment connections. The cables under supplier's scope shall be fire retardant Electron Beam Cross linked cables. For specific application i.e. PA/PIS, ETB, passenger alarm, fire detection system and door control, fire survival Electron Beam Cross linked cables to be supplied as per EN 50200 with minimum PH30. These cables shall be procured from RDSO approved sources. The Cables shall be suitably marked using Cable Markers for easy identification. Cables for terminal connections shall have only crimped joints. Vendor shall submit details (data sheet, GA etc.) of cables.
13. All the equipment viz. indication and instruments, panels, switches, ventilation control system, lighting, driver and guard seat, sunscreens and gauges etc. required to be installed in the cab, shall be supplied by the supplier except for TPWS/TCAS equipment and auto brake controller which shall be supplied by Indian Railways. As such the supplier shall have the complete responsibility of ergonomic design of driver's cab and supply, commissioning and interfacing of the complete cab equipment.

	TECHNICAL SPECIFICATION FOR DRIVER DESK WITH ASCCESSORIES	PROJECT- ICF Trainsets
	DOC. No.: PS4452961-part A, REV No. 00	

14. The layout of the equipment on driver's desk shall be finalized during design approval stage to maintain uniformity with cab arrangement of a similar Vande Bharat project of IR so that the cab layout remains same from driver's perspective to the extent feasible. Tentative layout of driver desk with its panels shall be as per annexure-II.
15. The design shall give an aesthetic look and the equipment shall be furnished in colour coordination. Fitment of various equipment on the panel shall be with proper finishing and proper IP protection against moisture and dust. Supplier shall submit the design in 3-D model of complete desk for cab layout.
16. The driver's desk shall include cut out for all the cab equipments e.g. combined master-cum-brake controller, gauges for pneumatic indications, PA/PIS, CCTV display, driver display unit, etc.
17. Bidder scope of items, Make, Part number and Quantity as per Annexure-I(A) (BOM) shall be approved by BHEL. The make and quantity shall be finalized during detailed engineering and the same shall be subjected to the approval of customer.
18. Legend of Driver's Desk Panel described in Drawing (Annexure-II) shall be finalized before manufacturing.
19. Design and manufacturing of Driver Desk with complete assembly shall be in accordance with EN 45545. The applicable Hazard level will be HL 3.

2.2 DRIVER DESK WITH ACCESSORIES

1. The tentative layout of driver desk and panels has been attached at Annexure-II. In case if RDSO/ICF/IR/nominated agency recommends some changes, the same has to be incorporated during detailed engineering.
2. Driver desk should have anchoring and earthing provision at appropriate position. All Electronics under the driver's desk shall be mounted in a mild steel structural frame with IP54 protection.
3. The driver desk switches and other components wiring shall be carried out by the desk supplier with 1 sq.mm / 1.5 sq mm/ 2.5 sq.mm E-beam irradiated, thin walled, halogen free, low smoke and less toxic cables according to relevant international standards as per cl. No. 2.1.1 (12) above. The cables shall use high-grade electrolytic copper stranded conductors tinned in accordance with Good Industry Practice. The Supplier shall submit details of cables conforming to EN 50264 & EN 50200 for fire retardant & fire survival characteristics. The cables shall be procured from any of the RDSO approved cable suppliers, as per wiring list provided by BHEL.
4. The equipment should be suitable for trainset applications and shall be mounted in driver's cab for which bidder shall submit detailed datasheets, drawings, test reports etc. and other relevant design documents. Mounting shall be finalized after discussion with RDSO/ICF/IR/Train manufacturer. Name plates (as per cl. No. 2.1 (8)) for all items mounted on driver desk shall be provided by the supplier on the desk itself.

	TECHNICAL SPECIFICATION FOR DRIVER DESK WITH ASCCESSORIES	PROJECT- ICF Trainsets
	DOC. No.: PS4452961-part A, REV No. 00	

5. Detailed type/routine test protocol of items must be submitted for approval of RDSO. If type test has already been done, then type test reports shall be submitted. All drawings shall be required in Auto-CAD and 3D drawings format. Project specific Operating/Maintenance manual needs to be submitted.
6. In each driver desk, following items shall be mounted by driver desk supplier at ICF/Train manufacturer place. These items are to be indicated in the drawings submitted by driver desk supplier. Drawings /dimension details of these items shall be furnished by BHEL. Fixing of these items and arranging of suitable hardware for fixing in driver desk shall be in scope of supplier. These items shall be supplied by BHEL at ICF/Train Manufacturer place:
 - a) Driver display unit (DDU)
 - b) DDU Cooling fan
 - c) Master controller
 - d) PAPIS MMI PANEL
 - e) PAPIS Manual Mode Operation unit for Head Code Indication
 - f) PAPIS Main Controller Unit
 - g) PAPIS GPS Antenna
 - h) PAPIS Microphone
 - i) Event recorder Microphone
 - j) Speed recorder cum Indicator
 - k) TCAS/AWS Display
 - l) CCTV Display,
 - m) Master controller/TCAS/MR/BP/BC connectors
 - n) MR & BP Pressure sensor, etc.

2.2.1 ELECTRIC HOOTER

Electric Hooter switches shall be provided on Desk as mentioned in Driver desk drawing of EAO or equivalent RDSO/ICF/IR approved make (proven design for traction application). The suitable Magnet valves required for actuation of pneumatic horns shall also be in scope of supplier procured from RDSO/ICF/IR approved supplier of proven performance. Details shall be finalized by supplier/vendor during detail design stage.

2.2.2 CONTROL SWITCHES AND INDICATORS

1. The control switches of M/s EAO make or equivalent RDSO/ICF/IR approved make (proven for traction application) shall be supplied. The tentative quantity that has been given below (refer Annexure-I (A)) is applicable for one driver desk. Type, Make, Color & Quantity shall be decided during detailed engineering as per end user requirement.
2. The control switches and indicators should be of same make throughout same P.O. quantity.
3. The Switches and Indicators shall have the following features: -

	TECHNICAL SPECIFICATION FOR DRIVER DESK WITH ASCCESSORIES	PROJECT- ICF Trainsets
	DOC. No.: PS4452961-part A, REV No. 00	

- a) The working voltage level of Switches shall be 110V DC.
- b) The Switches shall be provided with Screw terminal.
- c) Terminal Cover shall be provided for covering of screw terminal.
- d) All switch elements shall be with snap-action with Hard-Silver contacts except Emergency Stop switches, which for safety reasons shall be with slow-make contacts.
- e) Type, Quantity and Contact modules of EAO or equivalent make switches/indicators/push buttons/contact modules/etc. have been mentioned in Annexure-I (A) for reference. Exact type, number and other details shall be finalized in consultation with RDSO/ICF/IR/Train Manufacturer.
- f) All the switches shall be properly Marked (i.e. legend and name). Exact details shall be finalized in consultation with RDSO/ICF/IR/Train Manufacturer.
- g) Selector Switches shall be with Anti Twisting Ring.
- h) Numbering scheme of auxiliary contacts should not vary between different sets of supplies. As such, only one make of items should be supplied throughout entire order quantity.
- i) List of spare items is provided at Annexure-I (B). These are to be supplied as a set (same make and part no. as offered in Annexure-I (A)) only one time along with first set of supply. Delivery location of same shall be informed at later stage.

2.2.3 TERMINAL BOARDS ASSEMBLY

Terminal Boards Assembly of M/s. Wago Make or equivalent RDSO/ICF/IR approved make shall be required. The Terminal Boards should be properly marked with end plate stopper, etc. The TB type and quantity mentioned below is tentative, final TB quantity shall be finalized during detailed engineering.

The Following Types of TB Assembly shall be required on driver desk:

Type A— 1 Set of ‘Type A’ TB Assembly shall consist of:

- a) 4 Conductor Through Terminal Blocks with Front Entry, 2.5 Sq mm (Grey Colour) - 250 Nos.
- b) End Plate - 10 Nos.
- c) Screwless End Stop - 20 Nos.
- d) Adjacent Jumper - 10 Nos.
- e) Suitable Din Rail - 02 No.

ii) Type E —1 Set of ‘Type E’ TB Assembly shall consist of:

- a) 4 Conductor Through Terminal Blocks for earthing with Front Entry, 2.5 Sq. mm (Green Colour) - 30 Nos.
- b) End Plate - 6 Nos.
- c) Screwless End Stop - 08 Nos.
- d) Suitable Din Rail - 02 Nos.

iii) Type D — 1 Set of ‘Type D’ Diode TB Assembly shall consist of:

- a) 4 Conductor Through Terminal Blocks with Front Entry, 2.5 Sq mm (Grey Color) - 25 Nos
- b) End Plate - 2 Nos

2.2.4 CONNECTORS

**TECHNICAL SPECIFICATION FOR
DRIVER DESK WITH ASCCESSORIES**

DOC. No.: PS4452961-part A, REV No. 00

**PROJECT- ICF
Trainsets**

The supplier shall also provide the following connectors (Sl. No. 1 to 5 below) of Harting make or equivalent (proven for traction application) for each Driving Desk. Connector pins shall be selected appropriately as per wire size. Both male and female Connectors with Pins, Hood etc., along with Gland shall be in scope of supply of vendor. Part nos. has to be approved by ICF/RDSO/IR/nominated agency before supply. Final quantity shall be finalized during detailed engineering.

Sl. No. 1	32 PIN CONNECTOR (QTY. : 1 No.)			
Assy.	Part number	Qty.	Unit	Description
Male Assy.	19000005098	1	PC	Han CGM-M M40x1.5 D.22-32mm
	19300160438	1	PC	Han 16B-gg-QB-M40
	09320323001	1	PC	Han 32EE CRIMP TERM INSERT MALE
	09330006105	32	PC	Han E M Crimp Contact Ag 1.0 mm ² / 18 AWG
	09000005208	1	PC	Ground Terminal Size Han 16B
Female Assy.	09300160302	1	PC	Han 16B-HBM 4 pegs cover
	09320323101	1	PC	Han EE 32 Pos. Female Crimp Term.
	09330006205	32	PC	Han E F Crimp Contact Ag 1.0 mm ² / 18 AWG
	09000005208	1	PC	Ground Terminal Size Han 16B
Sl. No. 2	17 PIN+17 PIN CONNECTOR (QTY. : 2 Nos.)			
Assy.	Part number	Qty.	Unit	Description
Male Assy.	19000005095	1	PC	Han CGM-M M32x1.5 D.13-20mm/18-25mm
	19300060447	1	PC	Han B Hood Top Entry HC 2 Pegs M32
	09140060361	1	PC	Han hinged frame plus, 2 mod A-B KNBN
	09140173001	2	PC	Han DDD module, crimp male
	09150006122	34	PC	R 15-STI-C-1.0 QMM (Au)
Female Assy.	09300060301	1	PC	Han B Base Panel 1 Lever
	09140060371	1	PC	Han hinged frame plus for 2 mod a-b KNBN
	09140173101	2	PC	Han DDD module, crimp female
	09150006222	34	PC	R 15-STI-C-1.0 QMM (Au)

**TECHNICAL SPECIFICATION FOR
DRIVER DESK WITH ASCCESSORIES**

DOC. No.: PS4452961-part A, REV No. 00

**PROJECT- ICF
Trainsets**

Sl. No. 3	46 Pin Connector (Qty. 5 Nos.)			
Assy.	Part number	Qty.	Unit	Description
Male Assy.	19000005099	1	Pc	Han CGM-M M40x1.5 D.20-26mm/22-32mm
	19300240438	1	PC	Han 24B-gg-QB-M40
	09320463001	1	PC	Han EE 46 Pos. Male Crimp Term.
	09000005280	1	PC	Schirmbügel Han 24B
	09330006105	46	PC	Han E M Crimp Contact Ag 1.0 mm ² / 18 AWG
	09330009908	2	Pc	Han Coding System Guide Pin
	09330009909	2	Pc	Han Coding System Guide Bush
Female Assy.	09300240302	1	PC	Han B Base Panel 4 Pegs Thermoplastic Co
	09320463101	1	PC	Han EE 46 Pos. Female Crimp Insert
	09000005280	1	PC	Schirmbügel Han 24B
	09330006205	46	PC	Han E F Crimp Contact Ag 1.0 mm ² / 18 AWG
	09330009908	2	Pc	Han Coding System Guide Pin
	09330009909	2	Pc	Han Coding System Guide Bush

Sl. No. 4	64 Pin connector (Qty. 1 No.)			
Assy.	Part number	Qty.	Unit	Description
Male Assy.	19000005099	1	Pc	Han CGM-M M40x1,5 D.20-26mm/22-32mm
	19300240438	1	PC	Han 24B-gg-QB-M40
	09320643001	1	PC	Han 64 EEE male insert crimp
	09330006105	64	PC	Han E M Crimp Contact Ag 1.0 mm ² / 18 AWG
	09330009908	2	Pc	Han Coding System Guide Pin
	09330009909	2	Pc	Han Coding System Guide Bush
Female Assy.	09300240302	1	PC	Han B Base Panel 4 Pegs Thermoplastic Co
	09320643101	1	PC	Han 64 EEE-F-C
	09330006205	64	PC	Han E F Crimp Contact Ag 1.0 mm ² / 18 AWG
	09330009908	2	Pc	Han Coding System Guide Pin
	09330009909	2	Pc	Han Coding System Guide Bush

	TECHNICAL SPECIFICATION FOR DRIVER DESK WITH ASCCESSORIES	PROJECT- ICF Trainsets
	DOC. No.: PS4452961-part A, REV No. 00	

Sl. No. 5	(Han 4 Quintax 4 module + Han DD 2 module) Qty. 2 Nos			
Assy.	Part number	Qty.	Unit	Description
Male Assy.	09300240302	1	PC	Han B Base Panel 4 Pegs Thermoplastic Co
	09140240371	1	PC	Han hinged frame plus, for 6 modules a-f
	09140023001	2	PC	Han-Quintax module, male
	09150043013	4	PC	Han 4 Quintax Stift, 3-9.5mm
	09140009915	2	Pc	Han-Quintax metal adapter
	09140123002	2	PC	Han DD module, crimp male
	09150006125	40	PC	R 15-STI-C-0.75 QMM (AU)
	09330009908	2	Pc	Han Coding System Guide Pin
	09330009909	2	Pc	Han Coding System Guide Bush
Female Assy.	19000005099	1	PC	Han CGM-M M40x1.5 D.20-26mm/22-32mm
	19300240438	1	PC	Han 24B-gg-QB-M40
	09140240361	1	PC	Han hinged frame plus 6 modules A-F KNBN
	09140023101	2	PC	Han-Quintax module, female
	09150043113	4	PC	Han 4 Quintax Buchse, 3-9.5mm
	09140009915	2	Pc	Han-Quintax metal adapter
	09140123102	2	PC	Han DD module, crimp female
	09150006225	40	PC	Han D F Crimp Contact 0.75mm ² Au
	09330009908	2	Pc	Han Coding System Guide Pin
09330009909	2	Pc	Han Coding System Guide Bush	

2.2.5 DIAGRAM BOOK HOLDER, TIME TABLE HOLDER AND BOTTLE HOLDER

Suitable provision to keep time table, diagram, logbook & bottle shall be provided in driver desk and details shall be finalized with BHEL/ICF/train bulider.

2.2.6 BATTERY VOLTMETER

Battery Voltmeter of range 0-150V DC of analog type (Self illuminated with LED) (proven for traction application) shall be procure from RDSO/ICF/IR approved supplier of proven performance.

	TECHNICAL SPECIFICATION FOR DRIVER DESK WITH ASCCESSORIES	PROJECT- ICF Trainsets
	DOC. No.: PS4452961-part A, REV No. 00	

2.3 ACCESSORIES

2.3.1 DRIVER SEAT AND GUARD SEAT

The Driver and guard seat to be supplied as per existing operational Trainsets of M/s FISA make model no. SLIM 450M or its equivalent. The seat needs to be approved by RDSO/ICF/Railways. Reference drawing for seat is attached at Annexure – III. The offered seat should have the minimum following features:

- (i) Seat is designed as per standard UIC 651/612.
- (ii) PU Cushioning cover with fire barrier. Fire barrier as per EN45545 HL3.
- (iii) Upholstery material is as per customer approval.
- (iv) All structural part considering of carbon steel.
- (v) Painting according (color RAL 9005 Matt Black).
- (vi) General tolerance of foam 10 mm.
- (vii) Seat is middle position that is 90mm forward and 90mm backward from middle position.
- (viii) All fasteners torque tightened as per IS:1367-8-2002.

2.3.2 SUN SCREEN / VISOR

The sun screen to be supplied as per existing operational Trainsets with adjustable tension and roller mechanism arrangement. The sun screen needs to be approved by RDSO/ICF/IR/Train Manufacturer. Reference drawing for sun screen is attached at Annexure – IV.

- (i) The Sun Screen shall be ergonomically, functionally superior and aesthetically appealing finish.
- (ii) Sun Screen width should not be less than lookout window clear opening.
- (iii) Sun Screen should be perfectly guided at both sides without any sagging or hanging obstructing the clear vision of driver.
- (iv) Sun Screen should be able to hold at any desired position as per the convenience of driver for good lookout of track.
- (v) All material used for Sun Screen shall be of fire retardant type.
- (vi) Colour for the Screen shall have antifungal characteristics and fail resistance to fungal spore suspension.
- (vii) The sun screen shall have UV – Protection.
- (viii) All fasteners used shall be stainless steel material.
- (ix) The sun screen shall have proper access for ease of maintenance and access during service and trouble shooting.
- (x) Any minor change required during installation shall be carried out by supplier.

In addition to the above mentioned technical requirements, driver's desk and accessories and the entire wiring and bundling shall conform to relevant IECs/other applicable standards.

	TECHNICAL SPECIFICATION FOR DRIVER DESK WITH ASCCESSORIES	PROJECT- ICF Trainsets
	DOC. No.: PS4452961-part A, REV No. 00	

2.4 EQUIPMENT TESTING

- (a) Valid Type test report is to be submitted for the equipment along with offer, if the equipment is already type tested. In case, ultimate customer insists to repeat the type tests due to any reason, the type test shall be conducted again by the supplier, for which test procedure shall also be submitted by the supplier for approval before conducting the type test. In case ultimate customer desires to witness the type tests, the supplier shall have no objection. The supplier is required to quote for the type test charges if any, separately in commercial offer. These charges will be loaded in the equipment price at the time of final evaluation. If Type Test charges are not quoted separately in the commercial offer, then it will be presumed that offer is inclusive of type test charges and no extra payment will be done in case of type test conducted due to any reason.
- (b) Supplier to submit Routine test certificates and inspection certificate of equipment as per QAP along with equipment.
- (c) Type and routine test will also confirm to clause 3.13 of section 3 of technical specification.

	TECHNICAL SPECIFICATION FOR DRIVER DESK WITH ASCCESSORIES	PROJECT- ICF Trainsets
	DOC. No.: PS4452961-part A, REV No. 00	

2.5 DESIGN REQUIREMENTS TO BE PROVIDED BY SUPPLIER

<ul style="list-style-type: none"> • Write-up/ description of each equipment 	To be provided by Supplier
<ul style="list-style-type: none"> • Datasheet of equipment 	To be provided by Supplier.
<ul style="list-style-type: none"> • Circuit diagram, connection & wiring diagram, equipment drawing with mounting details, weights, center of gravity, etc. and any other relevant drawings 	To be provided by Supplier
<ul style="list-style-type: none"> • Driver's visibility diagram as per UIC 651 	To be provided by supplier along with technical offer
<ul style="list-style-type: none"> • Type test protocol & procedure/ Type test reports 	Supplier to submit the complete reports of type test along with technical offer already conducted on the proposed/offered equipment. In case type test is required to be done, supplier to submit the detailed test procedures for approval.
<ul style="list-style-type: none"> • Routine test protocol & procedure/ Routine test reports 	Supplier to submit Routine test reports and inspection certificate of equipment along with technical offer as per QAP
<ul style="list-style-type: none"> • Details of proven design 	To be provided by Supplier
<ul style="list-style-type: none"> • Performance statement 	To be provided by Supplier along with technical offer in the attached format.
<ul style="list-style-type: none"> • Performance certificate 	To be provided by Supplier along with technical offer in the attached format.
<ul style="list-style-type: none"> • RDSO Approval letter (conforming to the latest RDSO spec as applicable) 	To be provided by along with technical offer Supplier
<ul style="list-style-type: none"> • Project specific AUTO CAD drawing-2D and 3D model 	To be provided by Supplier after order placement for BHEL/RDSO/ICF approval
<ul style="list-style-type: none"> • Project Specific Drawings in A3 size 	To be provided by Supplier
<ul style="list-style-type: none"> • Technical Manual 	To be provided by Supplier
<ul style="list-style-type: none"> • Installation, Operational and Maintenance Manual 	To be provided by Supplier
<ul style="list-style-type: none"> • MTBF/MDBF Values along with the method of calculation 	To be provided by supplier along with technical offer
<ul style="list-style-type: none"> • Quality assurance plan (QAP) 	To be provided by along with technical offer supplier

	TECHNICAL SPECIFICATION FOR DRIVER DESK WITH ASCCESSORIES	PROJECT- ICF Trainsets
	DOC. No.: PS4452961-part A, REV No. 00	

SECTION – 3

PROJECT DETAILS AND GENERAL SPECIFICATIONS

3.1 GENERAL

This section stipulates the General Technical Requirements under the contract and forms an integral part of the Technical Specification. The provisions under this section are intended to supplement general requirements for the materials, equipment and services covered under other sections and are not exclusive.

However, in case of conflict between the requirements specified in this section and requirements specified under other sections, the requirements specified under respective sections shall hold good.

The Train shall be Distributed Power type which shall have Driving Cabs on its both ends and shall be capable of running in either direction without the requirement for any change in its composition. Configuration of 16-car rake shall be two End Basic Units and two Middle Basic Units.

The configuration of Vande Bharat express (Trainsets) is as under (for reference):

DTC-MC-TC-MC-MC-TC-MC-NDTC-NDTC-MC-TC-MC-MC-TC-MC-DTC

Where,

DTC: Driving Trailer Coach

MC: Motor Coach

NDTC: Non-Driving Trailer Coach

TC: Trailer Coach

3.2 INSTRUCTION TO BIDDERS

The bidders shall submit the technical requirements, data and information as per the technical specification, provided in Section-2.

The bidders shall furnish catalogues, engineering data, technical information, design documents, drawings etc. in English language, fully in conformity with the technical specification.

Whenever required, the bidder shall depute his technical experts to RDSO / nominated agency for design discussions and approval.

3.3 GENERAL DESIGN REQUIREMENTS

- i) The stock fitted with the supplied equipment shall meet the operating, service conditions and performance requirements of this specification and shall be suitable for operating conditions on IR.

	TECHNICAL SPECIFICATION FOR DRIVER DESK WITH ASCCESSORIES	PROJECT- ICF Trainsets
	DOC. No.: PS4452961-part A, REV No. 00	

- ii) All equipment shall be vandal proof and incorporate necessary anti-pilferage features without compromising aesthetics / maintainability.
- iii) Notwithstanding the contents of this specification, the Supplier shall ensure that the equipment supplied by them is complete in all respect so as to achieve the efficient operation & optimum performance of the Train set.
- iv) The equipment design shall incorporate all essential features necessary to yield high traffic use, low maintenance requirements, easy maintainability, high regeneration, high efficiency, light in weight, user & environment friendly and high reliability in train operation. The design shall also facilitate easy erection, inspection, maintenance and replacement of the sub-units/ assemblies of all the equipment.
- v) The entire equipment shall be designed to ensure satisfactory and safe operation under the running conditions mentioned in this specification duly taking care of sudden variations in load, voltage etc. under abnormal working conditions due to faulty operation, short circuits & earth faults etc.
- vi) Wherever applicable: Airflow inlet/ arrangement for forced cooled equipment shall be designed in such a way that cloth, polythene, papers etc., which may get sucked, either do not block the airflow or get removed during halts. Moreover, filter should be easily cleanable.
- vii) All working parts of the control and auxiliary circuit specifically electronics and PCBs, shall be suitably covered to keep them free from moisture, mold growth and dust. The protection level shall be furnished by the Supplier during design approval.
- viii) All the electrical equipment shall comply with the latest edition of governing IEC specifications unless otherwise specified. The temperature rise shall be measured according to the procedure stipulated by IEC and shall comply with the limits specified and the ambient conditions defined in the Specification.
- ix) All equipment shall be adequately earthed, insulated, screened or enclosed. They shall be provided with essential interlocks & keys as may be adequate to ensure the protection of the equipment and the safety of those concerned with its operation and maintenance.
- x) Wherever applicable: Supplier shall to the extent feasible employ the currently available lubricants/cooling oils in India. Full lubrication scheme and schedule for the equipment shall be submitted. If use of imported lubricants or cooling oil is inevitable, supplier shall furnish details of equivalent Indian lubricants/oil.
- xi) Supplier shall submit 3D models of offered equipment including associated sub-assemblies, etc. in. stp formats.

	TECHNICAL SPECIFICATION FOR DRIVER DESK WITH ASCCESSORIES	PROJECT- ICF Trainsets
	DOC. No.: PS4452961-part A, REV No. 00	

xii) The design of the equipment shall be based on sound, proven and reliable engineering practices. The equipment used in different sub systems shall be of proven technology and design. The supplier shall submit the supportive document for each of the assembly/sub-assembly for its proven performance under the environmental conditions prevalent in India.

xiii) The supplier shall design the mounting arrangements suitable for coaches. The accessories for mounting the equipment shall be part of the scope of supply. The hardware for mounting, safety links for underslung equipment, the termination hardware also will be in the scope of supply for all equipment.

xiv) SOFTWARE (WHEREVER APPLICABLE)

- a. Software shall be written in a structured manner and fully documented during all stages of its design and development. This shall meet the requirements of EN 50126-2: The specification and Demonstration of Reliability, Availability, Maintainability and Safety (RAMS) - Part 2, EN 50128: Railway Applications: Software for Railway Control and Protection Systems, and EN 50129: Safety-related Electronic Railway Control and Protection Systems.
- b. The Supplier shall submit the values of parameters, list of fault messages, their environmental data, hierarchy of fault display, fault categorization, trouble shooting of each fault by way of Changes in parameters shall be demonstrated with their effect on the results.
- c. Parametric changes shall be possible in the software in order to meet the future requirements. While listing out the values of various parameters, the Supplier must provide a range within which any change can be made without jeopardizing the functionality of the system. Supplier shall submit the licensed software to the purchaser.
- d. Software shall be fine-tuned through simulations & real life working conditions based on the extensive trials, associating BHEL / user Railways before putting the rake in commercial services. As it requires, instrumentation and expertise of Software Design Professionals, software expert(s) of Supplier shall be based at the work place along with commissioning engineers so that all software related issues are expeditiously resolved before putting the rake into commercial service.
- e. Quality and efficacy of trouble shooting manual, software tools and software documentation shall be validated during extensive field trials. Final version of these documents shall include the changes required based on the service trials, commercial service operation, experience of operating Railways.



TECHNICAL SPECIFICATION FOR DRIVER DESK WITH ASCCESSORIES

DOC. No.: PS4452961-part A, REV No. 00

PROJECT- ICF
Trainsets

- f. All the changes, thereafter, in software shall be approved by RDSO / nominated agency in consultation with user Railways before actual implementation and the Supplier must give software release, which shall include brief description of the problem, earlier as well as modified logic, explanation, parametric changes etc. to the satisfaction of RDSO / nominated agency.
- g. The Supplier shall submit Software Quality Plan for review before work commences on software design. The software quality plan shall clearly state the controls and practices used in the software life cycle from specification through to in-service operation.
- h. Internal independent review, verification & testing, using real & synthetic data, shall be performed at the software module and system level. RDSO/ nominated agency / BHEL / user Railway may audit the Supplier against the **Software Quality Plan** at any stage during the Contract. The Supplier shall ensure that all software is fully de- bugged prior to the final review by RDSO/user Railway.
- i. Sufficient software documentation shall be provided to give the full understanding of the software function, logics, parameters and operation. Documentation shall be complete, clear and concise, and include all modifications up to the final acceptance. Documentation shall clearly explain the software logics, associated parameters, include software block diagram showing signal flow, logic and hardware interfaces etc. A top level flow diagram and description of detailed operation shall be provided.
- xv) Notwithstanding the contents of this specification, the supplier shall ensure that the equipment supplied by them is complete in all respect so as to enable the desired operation of the Train fitted with their equipment.
- xvi) Supplier shall deliver the executable files of all developed software along with necessity tools to upload / download and carry out fault analysis.

3.4 INGRESS PROTECTION

- i) All equipment shall be suitably protected from dust and water. As a minimum, equipment shall be sealed to the standards stated below:

Under frame & externally mounted equipment (other than traction/ auxiliary converter/Traction Motor)	IP65
Battery Box and Brake Chopper	IP20
Equipment mounted inside the Car body	IP54

- ii) It may be necessary to protect some equipment to IP 67 in order to meet the requirements of Clause 3.5 of this Specification.



TECHNICAL SPECIFICATION FOR DRIVER DESK WITH ASCCESSORIES

DOC. No.: PS4452961-part A, REV No. 00

PROJECT- ICF
Trainsets

3.5 AMBIENT CONDITIONS / OPERATING CONDITIONS

The equipment shall be designed to work satisfactorily under following environmental conditions: -

Atmospheric temperature	Maximum temperature: 50 degrees Celsius Maximum touch temperature of metallic surface under the Sun: 75 degrees Celsius and in shade: 55 degrees Celsius Minimum temperature: - 10 degree Celsius
Humidity	100% saturation during rainy season
Solar radiation	1 kW/m ²
Altitude	1000 meter above mean sea level
Rain fall	Very heavy and continuous rainfall in certain areas (up to 2500 mm during rainy season)
Atmospheric conditions	Extremely dusty and desert terrain in certain areas. The dust concentration in air may reach a high value of 1.6 mg/m ³ . In many iron ore and coal mine areas, the dust concentration is very high affecting the filter and air ventilation system
Coastal area	Humid and salt laden atmosphere. The equipment shall function in accordance with this Specification when subjected continuously to a humid and salt laden atmosphere with maximum pH value as per IEC 60571, sulphate content of 7 mg per litre, maximum concentration of chlorine 6 mg per litres and maximum conductivity of 130 micro Siemens / cm.
Vibration	The vibration and shock levels recorded on various Sub-systems in existing Trains of IR are generally more than the limits given in IEC 61373 particularly at axle box, and traction motor. Accelerations over 50g have been recorded at axle box levels during run. Vibrations during wheel slips are of even higher magnitude. High level of vibrations above 30g have been measured at traction motor on IR's Trains, which increase up to 50g with worn gear- pinion.
Wind speed	High wind speed in certain areas, with wind pressure reaching 216 kg/m ² as per IS:875 Part 3(2015)
Flood level	The Train shall function in accordance with these Specifications and Standards in the event of flooding up to 203 mm above Rail Level as follows: <ul style="list-style-type: none">• In the event of flooding at any level below Rail Level, the Train shall operate in full compliance with these Specifications and Standards.• In the event of flooding at a height between Rail Level and 203 mm above Rail Level, the Train shall operate in full compliance with these Specifications



TECHNICAL SPECIFICATION FOR DRIVER DESK WITH ASCCESSORIES

DOC. No.: PS4452961-part A, REV No. 00

PROJECT- ICF
Trainsets

	<p>and Standards with the exception that it is permissible to restrict the operation of the Train to a maximum of 8 km/h.</p> <p>Allowance is to be made in addition for increase in the height of water level due to the “bow wave” effect of the Train passing through the water.</p>
Flood Proofing of the under slung Equipment	<p>Waterproofing test will be conducted on Traction and Auxiliary Converter by dipping them up to a height equivalent to 650 mm from rail level (under fully wheel worn condition) in stationary water for 12 hours. There should be no water ingress and Converters shall function normal after the test. Traction Motor with gearbox shall be tested for waterproofing as defined in clause 3.4.6.10.1 of specification ICF MD SPEC-398, issue status-01, rev 01. Other underslung equipment shall have IP protection as mentioned in clause 3.4 of this specification. However, even in case of flood levels more than the mentioned above, the equipment shall not get damaged and it should be possible to rejuvenate the equipment with minor attention without any adverse effect on their performance. Axle box shall be adequately flood proof.</p>

3.6 STANDARDS

- (a) The standards applicable and relevant to the complete Train and to the various Sub-systems and systems shall be:
- (i) IEC publications;
 - (ii) EN;
 - (iii) UIC;
 - (iv) AAR;
 - (v) IEEE;
 - (vi) BS;
 - (vii) RDSO specifications;
 - (viii) ICF/RCF specifications;
 - (ix) NF-F;
 - (x) ORE;
 - (xi) VDE;
 - (xii) UL;
 - (xiii) JIS
 - (xiv) IS; and
 - (xv) Any other standards referred to in this Schedule.
- (b) In the event of any contradiction in the aforesaid standards, the following standards shall have priority in the order listed:
- (i) Standards mentioned in these Specifications and Standards set forth herein;
 - (ii) EN/IEC/UIC/AAR and
 - (iii) IS.

	TECHNICAL SPECIFICATION FOR DRIVER DESK WITH ASCCESSORIES	PROJECT- ICF Trainsets
	DOC. No.: PS4452961-part A, REV No. 00	

(c) For avoidance of any doubt, in case of any conflict between the requirements of these standards, the stipulations of Specifications and Standards in this Schedule shall have precedence.

(d) The temperature rise shall be measured according to the procedure stipulated by IEC and shall comply with the limits specified and the ambient conditions defined in the Specification. Specified temperature rise of equipment shall be calculated after taking into account at least 25% choking of air filters and radiator fins etc.

3.7 ENGINEERING DATA

- (a) The contactor shall necessarily submit all the drawings/ documents unless anything is waived. The contactor shall submit drawings/ design documents/ data/ test reports as may be required for the approval of the purchaser. All drawings submitted by the Manufacturer including those submitted at the time of bid shall be in sufficient detail to indicate the type, size, arrangement, material description, Bill of Materials, weight of each component, break-up for packing and shipment, the external connections, fixing arrangement required, dimensions required for installation and interconnections with other equipment and materials, clearances and spaces required for installation and interconnections between various portions of equipment and any other information specifically requested in the specifications.
- (b) Each drawing submitted by the Manufacturer shall be clearly marked with the name of the Customer and Project, the unit designation, the specifications title, the specification number, date of revision (if any), duly signed by the concerned technical person. If standard catalogue pages are submitted, the applicable items shall be indicated therein and should be made project specific. All titles, noting, markings and writings on the drawing shall be in English. All the dimensions should be in metric units.
- (c) The title block of drawings shall contain the following information incorporated in all contract drawings

1. Customer : BHEL /Indian Railways
2. Project: Manufacturing cum Maintenance of Vande Bharat Trainsets
3.Contract No./LOA No./ Ref no.: 2022/RS(WTA)-527/Vande Bharat Trains/874/1 dated 14/06/23
4. Main Contractor : Bharat Heavy Electricals Limited

3.7.1 SIZE OF DRAWINGS

The drawings of the following parts shall be to the sizes indicated below

- I. Equipment details – full size or half size
- II. Motor Assemblies – 1:5
- III. General Assemblies- 1:10

Further, the scaling of drawings should be as per applicable standards.

	TECHNICAL SPECIFICATION FOR DRIVER DESK WITH ASCCESSORIES	PROJECT- ICF Trainsets
	DOC. No.: PS4452961-part A, REV No. 00	

3.7.2 METHOD OF FILING OF DRAWINGS

To facilitate filing of drawings, it is essential that each drawing submitted for approval is marked so that it can be identified. The supplier is, therefore, required to ensure that all prints are marked legibly at the right hand bottom corner. The following information is required in respect of each drawing:

- I. Supplier's drawing number.
- II. Supplier's name and date of submission.
- III. Contract no. given by the purchaser.
- IV. Description of drawings.
- V. Relevant Specifications

3.8 MARKING OF EQUIPMENT & RATING PLATE

- (a) All main assemblies of the equipment shall bear serial number, year of manufacture and symbol/ identification of the purchaser. Where the sub- assemblies/components of the main assemblies are not inter-changeable, the sub-assemblies shall also be marked with the serial nos. of the main assembly of which they form a part.
- (b) All equipment/cubicles shall contain non-detachable rating plates of anodized aluminium with embossed letters and fitted in a visible position. The rating plate will give detailed rating specification and identification of equipment.

3.9 INFRINGEMENT OF PATENT RIGHTS

BHEL and Indian Railway shall not be responsible for infringement of patent rights arising due to similarity in design, manufacturing process, components used in design, development and manufacturing of propulsion system & other equipment and any other factor which may be a cause such dispute. The responsibility to settle any issue lies with the manufacturer.

3.10 DOCUMENT SUBMISSIONS

The scheduled dates for the submission of these as well as for, any data/information to be furnished by the Purchaser would be discussed and finalized at the time of award. The following schedule shall be followed generally for approval:

Sl.no.	No. of copies	Schedule
i)	Initial Submission Drawings, Data sheets, Type test Reports	At the time of submission of offer.
ii)	Furnishing of drawings in hard / soft copy format	Approx 2 to 3 weeks from the date of award of contract.

	TECHNICAL SPECIFICATION FOR DRIVER DESK WITH ASCCESSORIES	PROJECT- ICF Trainsets
	DOC. No.: PS4452961-part A, REV No. 00	

iii)	Furnishing of type test reports in hard / soft copy format	Hard / soft copy to be submitted immediately after the completion of the test.
iv)	Furnishing of routine test reports	Hard / soft copy to be submitted immediately after the completion of the test.
v)	All documents including Installation, Operation & Maintenance manuals.	Approx 2 to 3 weeks from the date of award of contract.

3.11 QUALITY ASSURANCE PROGRAMME

- (a) To ensure that the equipment and services under the scope of this Contract, whether manufactured or performed within the Manufacturer's Works or at his Sub-manufacturer's premises or at the Purchaser's site or at any other place of Work, are in accordance with the specifications, the Manufacturer shall adopt a suitable quality assurance program to control such activities at all points, as necessary. Such program shall be outlined by the Manufacturer and shall be finally accepted by the Purchaser
- (b) A quality assurance program of the manufacturer shall generally cover the following:
- I. Manufacturer's organization structure for the management and implementation of the proposed quality assurance program;
 - II. Documentation control system;
 - III. Qualification data of bidder's key personnel;
 - IV. The procedure for purchases of materials, parts components and selection of sub-Manufacturer's services including vendor analysis, source inspection, incoming raw material inspection, verification of material purchases etc.
 - V. System for shop manufacturing and site erection controls including process controls and fabrication and assembly control;
 - VI. Control of non-conforming items and system for corrective actions;
 - VII. Inspection and test procedure both for manufacture and field activities;
 - VIII. Control of calibration and testing of measuring instruments and field activities;
 - IX. System for indication and appraisal of inspection status;
 - X. System for quality audits;
 - XI. System for authorizing release of manufactured product to the Purchaser
 - XII. System for maintenance of records;
 - XIII. System for handling storage and delivery; and
 - XIV. A quality plan detailing out the specific quality control measures and Procedures adopted for controlling the quality characteristics relevant to each item of equipment furnished and/or services rendered.

	TECHNICAL SPECIFICATION FOR DRIVER DESK WITH ASCCESSORIES	PROJECT- ICF Trainsets
	DOC. No.: PS4452961-part A, REV No. 00	

(c) The Purchaser or his duly authorized representative reserves the right to carry out quality audit and quality surveillance of the system and procedure of the Manufacturer/'his vendor's quality management and control activities.

3.12 QUALITY ASSURANCE DOCUMENTS

The Manufacturer shall be required to submit the Quality Assurance Documents as stipulated in the quality plan at the time of purchaser's inspection of equipment/material.

3.13 TYPE AND ROUTINE TESTING & INSPECTION

1. The individual prototype equipment, systems and sub- systems shall be type and routine tested in accordance with the relevant IEC/UIC/EN publications inclusive of the mandatory and optional tests along with the special tests as specified.
2. All type tests shall be conducted by Supplier or such other agency or person agreed by RDSO / Nominated Agency at the Supplier's cost where ever performed in presence of and to the satisfaction of RDSO/ Nominated Agency, who reserves the right to witness any or all of the tests. All tests set forth in this specification shall be conducted by the Supplier or other agency or competent person as agreed by the purchaser/ RDSO/ Nominated Agency.
3. RDSO / Nominated Agency may waive some of these tests in case of equipment/ sub-assemblies where the manufacturer can establish to the satisfaction of RDSO that such tests have already been carried out earlier. In such a case, manufacturer shall submit complete test reports along with necessary certification.
4. Wherever any equipment, system, sub system is not specifically covered by an international recognized specification or test procedure, the tests which are acceptable to both to Supplier and to the IR's representative shall be devised.
5. Without prejudice to any provisions of the contract, the purchaser reserves the right to witness any or all of the type tests and to require submission of any or all test specification and reports.
6. In case any bidder indicates that he shall not carry out a particular test, his offer shall be considered incomplete and shall be liable to be rejected.
7. The Purchaser, his duly authorized representative and/or outside inspection agency acting on behalf of the Purchaser shall have at all reasonable times free access to the Contractors premises or Works and shall have the power, at all reasonable times to inspect and examine the materials and workmanship of the works during its manufacture or erection if part of the Works is being manufactured or assembled at other premises or works, the Manufacturer shall obtain for the Engineer and for his duly authorized representative permission to inspect as if the works were manufactured or assembled on

	TECHNICAL SPECIFICATION FOR DRIVER DESK WITH ASCCESSORIES	PROJECT- ICF Trainsets
	DOC. No.: PS4452961-part A, REV No. 00	

the Manufacturer's own premises or works. Inspection may be made at any stage of manufacture, dispatch or at site as the option of the Purchaser and the equipment if found unsatisfactory due to bad workmanship or quality, material is liable to be rejected.

8. Supplier to depute qualified person for supervision of installation and commissioning of the equipment in the prototype rake. During the prototype tests/trials of train, if a technical problem arises with the equipment, qualified supplier representative should be deputed to attend the same.
9. During the prototype tests/trials or service of train, if any problems arise or feedback information is obtained, which warrants a re-check of the design/manufacture/quality of the equipment and components, action will be taken as may be necessary by the Supplier to carry out the required investigations and to incorporate the improvements considered most appropriate to reach compliance with the specification without any extra costs to the Purchaser and in a manner approved by the RDSO/Nominated Agency on equipment/components already supplied as well as those to be supplied later.
10. The prototype rakes fitted with the supplied equipment, shall be subjected to pre-revenue service trials. Service trials are intended to prove the satisfactory running performance of the supplied Train set equipment and evaluate their reliability in service, ease of maintenance and operations. The performance of the equipment shall be assessed based on the experience gained during the service trials. Necessary modification as required and also as desired by the RDSO/ Nominated Agency / Indian Railway shall be implemented in the series production without any extra costs to the Purchaser.
11. **Type tests on electronic equipment and control electronics**
The electronic equipment and Control Electronics shall be tested as per IEC 60571/EN50155, IEC 60068, EN 50121, IEC 60721-2-5 and IEC 61373 including both compulsory and optional tests. Dry heat test, as specified in IEC 60571, shall be conducted for testing power and control electronic equipment at 80 degrees Celsius. LCD display units shall be tested at 70°C.

3.14 MATERIALS AND WORKMANSHIP

Equipment materials and components shall be new, of high grade and good quality and be to the latest engineering practice. The material and workmanship throughout shall be in accordance with the purpose for which they are intended. Each component shall be designed to be consistent with its duty.

3.15 PACKING, STORAGE AND HANDLING INSTRUCTIONS

All the equipment shall be suitably protected, coated, covered or boxed and crated to prevent damage or deterioration during transit, handling and storage at site till the time of erection. The manufacturer shall also submit packing details/ associated drawing for any equipment/ material before equipment dispatch.

	TECHNICAL SPECIFICATION FOR DRIVER DESK WITH ASCCESSORIES	PROJECT- ICF Trainsets
	DOC. No.: PS4452961-part A, REV No. 00	

All coated surfaces shall be protected against abrasions, impact, discoloration and any other damages. All exposed threaded portions shall be suitably protected with either a metallic or a non-metallic protecting device.

Storage requirements shall be clearly defined by the supplier. Packing shall be such that if required, long time storage at site should not deteriorate the performance of the equipment.

3.16 FIRE PREVENTION

- i) The design of equipment shall incorporate all measures to prevent fire, and will be such that should any fire take place, the effects shall be minimized and no spread of fire should take place. Materials that are not fire retardant shall not be used.
- ii) Materials used in the manufacture of equipment shall be selected to reduce the heat load, rate of heat release, propensity to ignite, rate of flame spread, smoke emission and toxicity of combustion gases.
- iii) The fire protection on Train shall be designed and constructed in accordance with EN 45545. The applicable Hazard level will be HL3.
- iv) Contractor shall furnish the relevant data, fire load calculations, certifications etc. of the items considered in fire load calculations separately for Above & Below the floor level. The calculations and validation shall conform to the standard adopted by the contractor for fire strategy.
- v) Relevant provisions stipulated in Central Electricity Authority (Measures related to Safety and Electric Supply) Regulations, 2010, shall be followed in the interest of safety of passenger/staff as well as for equipment / instruments provided in the coaches.

	TECHNICAL SPECIFICATION FOR DRIVER DESK WITH ASCCESSORIES	PROJECT- ICF Trainsets
	DOC. No.: PS4452961-part A, REV No. 00	

SECTION – 4

RELIABILITY, AVAILABILITY, MAINTAINABILITY AND SAFETY (RAMS)

4.1 KEY PERFORMANCE INDICATORS

Performance indicators comprises of Availability, Reliability and upkeep of Cars. The bidder must ensure RAMS parameters for the offered equipment and its sub-assemblies supplied to at least maintain the overall fleet availability and reliability targets given below. In case, fleet reliability drops on account of poor reliability of subassemblies supplied, the supplier will be required to improve the quality of subassemblies to match the availability & reliability targets.

a) Availability

Sum of Available Hours as a proportion of the total hours (Available Hours + Non-Available Hours) in the Fleet in any Accounting Year, shall be considered as “Availability”. Guaranteed Availability in every Accounting Year shall be at least 95%.

b) Reliability

Average Mean distance travelled between two Failures for the fleet in any Accounting Year shall be considered as “Reliability”. Guaranteed Reliability shall not be less than 200,000 km.

c) Upkeep

For the offered equipment, there shall be no such conditions during the operation of trains that affects the reliability, safety and passenger amenities. Any maintenance shall be conterminous with the train maintenance schedules as given in CI 4.5 of this section.

List of Conditions affecting Upkeep (As applicable) is enclosed as Annexure-A of this section.

4.2 RELIABILITY AVAILABILITY MAINTAINABILITY AND SAFETY (RAMS)

a) The supplier shall ensure that, Guaranteed Reliability, Guaranteed Availability and High Degree of Safety in order to provide a dependable service, forms an integral element of the offered products.

b) The plan for Reliability, Availability, Maintainability and Safety shall conform to EN 50126/ IEC 61709/ IEC 62278. Reliability of electronic components shall conform to IEC 61709.

c) The supplier shall develop and provide RAMS targets (MTBF/MDBF/MTBSF) for the offered equipment both for the complete system and for the major Sub-systems at ambient temperature up to 50°C.

	TECHNICAL SPECIFICATION FOR DRIVER DESK WITH ASCCESSORIES	PROJECT- ICF Trainsets
	DOC. No.: PS4452961-part A, REV No. 00	

d) After rectification of any failure / fault, the concerned equipment / system should resume its original performance / function.

e) Components critical for safety shall fall into safe operating mode in case of malfunctioning. The system safety plan shall identify and list safety critical components and this list shall be updated periodically and intimate to the purchaser.

f) Supplier shall submit the basic maintenance schedules of the proposed equipment. Minimum interval between two maintenance schedules in the depot for the equipment supplied should not be less than 90 days except for activities which can be done outside the base depot (such as cleaning of filters mounted in the under-frame, for which the periodicity shall not be less than 15 days) and 3 years for major works in workshop/major depot. Average running distance of a rake may be considered as 2000 kilometer per day. Please refer CI 4.5 below in respective planning of maintenance schedule for the supplied equipment.

g) All systems, components and structural areas serviced as part of inspection or periodic preventive maintenance shall be conveniently accessible for service and inspection.

4.3 RAMS DOCUMENTATION

Vendor shall agree to submit following documents pertaining to RAMS analysis:

- Functional breakdown + inherent failure analysis
- Mission critical failures Analysis (Fault Tree Analysis)
- FMECA (Failure Mode Effects and Criticality Analysis)
- System/Sub-Systems Hazard Analysis
- Hazard Log + SIL data (if applicable)
- List of critical components
- Preventive Maintenance Analysis
- Corrective Maintenance Analysis

4.4 SERVICE LIFE OF EQUIPMENT/SYSTEM

Vendor shall specify the service life of the offered equipment / system based on life cycle calculations after which the equipment / system shall call for complete replacement to maintain the required reliability & availability of fleet.



TECHNICAL SPECIFICATION FOR DRIVER DESK WITH ASCCESSORIES

DOC. No.: PS4452961-part A, REV No. 00

PROJECT- ICF
Trainsets

Annexure-A

List of Conditions affecting Upkeep of Trains.

S.No.	System name	Condition
1	Windscreen Wiper and Washer System	- Rainy weather, defective wiper in any cab.
2	Couplers (any type)	- Any mechanical/electrical/pneumatic fault and/or any dimensional misalignment and/or any damage to any part which does not allow the coupler to guarantee the fulfilment to its assigned mission, in accordance to the technical requirements, performance and safety set out in this specification.
3	Suspension	- Any defect in primary / secondary suspension resulting in passenger safety, comfort or performance.
4	Wheel	- If wheel flat is > 40 mm or as finalised in design. - Any abnormal hammering as reported by the TO.
5	Pantograph	- Isolation of any pantograph
6	Transformer	- Isolation of any one main transformer.
7	Battery charger	- Battery Charger of one unit isolated.
8	Mechanical drive system	- Any defect resulting in high temperature / isolation
9	Traction Motors	- Isolation of more than 25%motors.
10	Traction converters	- As per the consequential effect as defined in Item 10 above.
11	Main compressor unit	- Isolation of any Main Compressor Unit
12	Auxiliary converter-inverter	- Isolation of any Auxiliary Converter-Inverter unit.
13	Brake system (mechanical)	- If isolation of an additional bogie (mechanical) leads to speed restriction.
14	Exterior lights	- Failure of any head light / marker/tail light.
15	Driver's desk	- If master controller prevents the train from moving. - Any defect in master controller even if no delays are reported. - Any defective cab switch leading to unsafe operation.

	TECHNICAL SPECIFICATION FOR DRIVER DESK WITH ASCCESSORIES	PROJECT- ICF Trainsets
	DOC. No.: PS4452961-part A, REV No. 00	

16	TCMS & Vehicle circuits	<ul style="list-style-type: none"> - If HMI display fails & functionality is not transferred to redundant HMI. - Any failure in TCMS component / equipment /circuit element / software/communication system etc. resulting in loss of intended function. - Further cases will be included based on TCMS redundancy and configuration.
17	PIS & CCTV	<ul style="list-style-type: none"> - If both automatic and manual announcements fail - If announcements in Car is not audible - if ≥ 1 unit exterior side view CCTV not working - If >1 PEA in any car is defective - One saloon CCTV, including its backup if any, is isolated. - If ≥ 1 unit for rear cab and front cab camera, cameras on the roof
18	Passenger doors	<ul style="list-style-type: none"> - If ≥ 1 (one) door per train side is isolated.
19	HVAC (passenger area)	<ul style="list-style-type: none"> - Failure of any one HVAC in any car leading to increase in inside temperature $\geq 28^{\circ}\text{C}$ - Failure of two HVAC's in one car. - Noisy Air Conditioner: Interior Noise $>+2\text{dB}$ than the one recorded and validated during the type test at standstill)
20	Ground fault in DC Circuit	<ul style="list-style-type: none"> - Train to be withdrawn in case of single ground fault if it leads to unsafe operation as per the design.
21	A failure or symptom which may endanger safe and/or normal operation of train	<ul style="list-style-type: none"> - Failure in safety interlock or protection circuit such as door loop - Abnormal noise in underframe - Wheel flat - Arcing in pantograph - Failure of emergency equipment - Failure which may disable train's push out duty. - Train which that requires more than 2 instances of reset within 30 minutes - Jerky movement (The details shall be finalized in design stage). - Others to be decided during design stage

Note: The above list shall be further reviewed and updated during design stage.

4.5 TRAIN MAINTENANCE SCHEDULE (TENTATIVE)

Sl. No.	Schedule	Place of maintenance	Permissible time per schedule	Periodicity
1	Minor maintenance	Light maintenance at Depot	8 hours	3 months
2	AOH	Light maintenance at Depot	7 days	18 months
3	IOH	Heavy maintenance at Depot	10 days	36 months
4	POH	Heavy maintenance at Depot	20 days	72 months

	TECHNICAL SPECIFICATION FOR DRIVER DESK WITH ASCCESSORIES	PROJECT- ICF Trainsets
	DOC. No.: PS4452961-part A, REV No. 00	

SECTION -5

SPARES AND CONSUMABLES FOR MAINTENANCE

5.1 SPARES AND CONSUMABLES

- i) Supplier shall provide complete list of items/materials which get consumed during normal course of operation of the Train as applicable for the equipment/system (the “Consumables”).
- ii) Supplier shall provide complete list of parts or equipment/system ensuring fleet availability of 95% or better, which would be necessary for efficient operation and maintenance of the (the “Spares”).
- iii) Supplier shall provide detailed spare parts catalogue / data-sheet listing all components manufactured or purchased by the supplier along with their rating, source, type / model no., schematic, position, etc.
- iv) Price for above spares and consumables to be shared separately as part of commercial offer.

5.2 SCHEDULED MAINTENANCE

- a) Scheduled (Preventive) maintenance consists of operations to maintain an assembly/subassembly or components in its specific operating conditions by performing:
 - i) periodical inspection and diagnostic tests for prevention of malfunctioning.
 - ii) scheduled replacement of components.
 - iii) checks to be performed at specified time intervals, whose outcome determines whether or not replacements will be required.
 - iv) routine operations, such as filling, topping up, change oil, greasing, adjustments, etc.
 - v) general overhaul of systems and subsystems.
- b) The preventive maintenance schedules required to keep the supplied system in good fettle with requisite reliability and availability would be coterminous with the train maintenance schedules and it should be possible to comfortably complete such maintenance during the time provided for respective train maintenance schedule and in the facility provided (refer Chapter Reliability, Availability, Maintainability and Safety).
- c) Details of Schedule of Periodic / preventive maintenance (the “Scheduled maintenance”) shall be submitted in following sample format:

Nature of inspection / maintenance	Periodicity / Interval	Items to be replaced

	TECHNICAL SPECIFICATION FOR DRIVER DESK WITH ASCCESSORIES	PROJECT- ICF Trainsets
	DOC. No.: PS4452961-part A, REV No. 00	

- d) Scheduled Maintenance shall ordinarily not be required before a travel of 40,000 km (forty thousand kilometres).
- e) Supplier shall provide plan / activities for periodical inspection and diagnostic test for prevention of malfunctioning
- f) List of facilities including tools & tackles required for carrying out all scheduled maintenance activities to be provided by vendor.
- g) All systems, components and structural areas serviced as part of inspection or periodic preventive maintenance shall be conveniently accessible for service and inspection.

5.3 UNSCHEDULED MAINTENANCE

Unscheduled (Corrective) maintenance consists of maintenance operation which is not scheduled (part of preventive maintenance) as a result of an in-service failure.

The supplier shall be required to provide repair & maintenance instructions to put back the equipment / system back in service.

List of facilities including tools & tackles required for carrying out all unscheduled maintenance activities to be provided by vendor.

5.4 EPIDEMIC DEFECT WARRANTY

(a) If any identical defect or deficiency affecting Safety, Reliability and Availability of the trains on more than 20% (twenty per cent) of equipment or parts in any rolling period of 36 (thirty-six) months commencing from the second Year of the Supply Period, such defect or deficiency shall be deemed to be an epidemic defect (the "Epidemic Defect") and the supplier shall cover such Epidemic Defect under an epidemic defect warranty.

(b) In case, the Government (Railways) notifies an Epidemic Defect on account of the supplied assembly, the supplier shall remedy such Epidemic Defect on all such Trains where equipment or parts of that particular design or lot are provided, subject to limitation of period elapsed since commissioning as mentioned above in this para.

5.5 OPERATION AND MAINTENANCE MANUAL

- i) Supplier shall provide an operation manual (the "Operation Manual") for the offered equipment / system in soft copy format in English and Hindi language. The Operation Manual shall include (but not limited to):
 - a) Instructions for troubleshooting;
 - b) Rating and layout of equipment;
 - c) Operating limits of installed systems;
 - d) Control and safety features of the Equipment/System;
 - e) Instructions to Loco Pilots for operation of the Train (if applicable);
 - f) Do's and don'ts for Loco Pilots (if applicable);
 - g) Safety precautions to be taken by the Loco Pilots (if applicable);

	TECHNICAL SPECIFICATION FOR DRIVER DESK WITH ASCCESSORIES	PROJECT- ICF Trainsets
	DOC. No.: PS4452961-part A, REV No. 00	

- ii) The Maintenance Manual to be provided by supplier shall include:
- (a) All maintenance activities and their periodicities that are required to keep the Train safe and ensure that the prescribed tolerances of systems and components are not exceeded at any time, including any systems relevant to the maximum moving dimensions;
 - (b) The inspection program for regularly checking that the Train is safe to continuing in service;
 - (c) Assembly & disassembly sequences for the supplies with pictorial playbook guide
 - (d) The engineering facilities (such as pit facilities, special tools etc.) necessary for the mandated maintenance;
 - (e) Minimum competencies required by staff for the maintenance activities.
- iii) The Maintenance Manual shall ensure that safety critical systems and components on the Train are identified specifically and the minimum testing requirements that must be invoked in the event of their disturbance at examination or repair are defined.
- iv) Preparation of the Maintenance Manual shall give consideration to inspections, tests and maintenance of the following that have a bearing on safety:
- (a) inter-vehicular couplers.
 - (b) fire prevention system including safe working of pantry/ sub pantry equipment.
 - (c) Auxiliary electrical machines: Integrity and security, earthing condition and integrity, condition of safety labelling.
 - (d) Passenger Information System
 - (e) Cleaning: Ventilation ducts, filters, bogies and underframe equipment
 - (f) Power systems (including protection systems): Integrity and security earthing condition and integrity, condition of safety labelling.
 - (g) Pantographs: Integrity and security - dimensions and condition of pantograph head, over-height protection, earthing condition and integrity, condition of safety labelling.
 - (h) Train structures and underframes: Integrity and condition of all load bearing members or panels, integrity, operation and security of doors, openable and removable panels, integrity and security of all body mounted equipment, alignment, gangway.
 - (i) Safety systems (e.g. Vigilance control device): Functional tests;
 - (j) Hydraulic and pneumatic systems: Condition and integrity of hoses, pipework, valves, etc.
 - (k) Fire protection systems: Integrity and condition.
 - (l) Lighting Systems & Visibility: Headlight, flasher and marker lights, adjustment, intensity
 - (m) Speedometers; headlights and marker lights; horn; doors; cattle guard; and bio-vacuum toilets
- (v) The instructions within the Maintenance Manuals shall be such as to protect staff working on the Trains, with particular reference to safety precautions and implementing a specified safety condition of the Train prior to starting work.

	TECHNICAL SPECIFICATION FOR DRIVER DESK WITH ASCCESSORIES	PROJECT- ICF Trainsets
	DOC. No.: PS4452961-part A, REV No. 00	

5.6 OBSOLESCENCE MANAGEMENT

Supplier is required to manage obsolescence of all equipment, spares and consumables to enable the trains to continue in service for 35 years. This obsolescence management service must include:

- i) Timely identification of any obsolete items of equipment;
- ii) Development of mitigation strategies to minimize the impact of the imminent obsolescence of any item within the offered equipment / system including:
 - Establishing alternative supply paths;
 - Provision of equivalent or interchange parts or equipment
 - Development of replacement products or design modifications to accept market available alternatives.

CONFIDENTIAL

**TECHNICAL SPECIFICATION FOR
DRIVER DESK WITH ASCCESSORIES**

DOC. No.: PS4452961-part A, REV No. 00

PROJECT- ICF
Trainsets**ANNEXURE-I(A)****BOM - TENTATIVE LIST OF COMPONENTS / ITEMS**

SL. NO.	ITEM DESCRIPTION	CONTACT MODULES	MAKE/ PART NO.	Qty. (Nos.)	SCOPE
1	BOTTOM STRUCUTRE – (3MM THICK. STAINLESS STEEL GRADE - 409M, Grade No. BS EN10088-2)			1	VENDOR
2	FRP TOP CONSOLE (FRP MIN.5MM THICK) (MDTS:133, REV.05) (latest)			1	VENDOR
3	DRIVER DESK SUPPORT FRAME (IRSM:41-97)			1	VENDOR
4	MASTER CONTROLLER			1	BHEL
5	MOP DISPLAY UNIT (PAPIS)			1	BHEL
6	MIC (PAPIS) +MIC (AGP)			2	BHEL
7	DRIVER DISPLAY UNIT (DDU)			1	BHEL
8	SPEED RECORDER CUM INDICATOR			1	BHEL
9	FLASHER LIGHT CONTROL UNIT			1	BHEL
10	CCTV DISPLAY UNIT			1	BHEL
11	MR/BP DUPLEX GAUGE - 4 INCH			1	ICF
12	BC/AR GUAGE – 4 INCH			1	ICF
13	BP GAUGE – 6 INCH			1	ICF
14	PNEUMATIC PANEL (D0 PANEL)			1	ICF
15	AUTO BRAKE CONTROLLER			1	ICF
16	GUARD EMERGENCY VALVE			1	ICF
17	TCAS BUZZER			1	ICF
18	TCAS DISPLAY (LP-OCIP)			1	ICF
19	TCAS EMR ISO COCK			1	ICF
20	TCAS COMMON_BLACK			1	ICF
21	INDICATOR LIGHT WITH LED_SYSTEM HEALTHY / FAULT (BI COLOUR)			1	ICF
22	INDICATOR LIGHT WITH LED_SYSTEM EMERGENCY / SOS (BI COLOUR)			1	ICF
23	PB SWITCH, MOMENT, BLUE – ACK/CANCEL			1	ICF
24	PB SWITCH, MOMENT, RED– SOS			1	ICF
25	ATO			1	ICF
26	WATER BOTTLE HOLDER			2	VENDOR
27	VCD SWITCH -FOOT OPERATED			1	VENDOR
28	VCD BUZZER			1	VENDOR
29	FAULT BUZZER			1	VENDOR

**TECHNICAL SPECIFICATION FOR
DRIVER DESK WITH ASCCESSORIES**

DOC. No.: PS4452961-part A, REV No. 00

PROJECT- ICF
Trainsets

SL. NO.	ITEM DESCRIPTION	CONTACT MODULES	MAKE/PART NO.	Qty. (Nos.)	SCOPE
30	PA BUZZER			1	VENDOR
31	SIGNAL BELL BUZZER			1	VENDOR
32	SHORT LEV. SELECTOR SWITCH, 2P, MAINT, BLK - DRIVER CAB LIGHT (D)	2 NO.		1	VENDOR
33	SHORT LEV. SELECTOR SWITCH, 2P, MAINT, BLK - CAB EMR LIGHT	2 NO.		1	VENDOR
34	SHORT LEV. SELECTOR SWITCH, 2P, MAINT, BLK - DRIVER CAB SPOT LIGHT (D)	2 NO.		1	VENDOR
35	LONG LEV. SELECTOR SWITCH, 3P, MAINT, BLK - HEAD LIGHT (OFF/BRIGHT/DIM)	1 NO. + 3 NC.		1	VENDOR
36	PB SWITCH, MOMENT, ILLUM, LAMP - BLUE - BAT V TEST	1 NO.		1	VENDOR
37	WIPER CONTROL SWITCH (BLACK COLOR) 4 POSITION SWITCH	4 NO.		1	VENDOR
38	VOLTMETER (SELF ILLUMINATING) FLUSH MOUNTING MC RECTI TYPE			1	VENDOR
39	LONG LEV. SELECTOR SWITCH, 3P, MOMENT, BLK - PANTO (UP/DOWN)	6 NO.		1	VENDOR
40	LONG LEV. SELECTOR SWITCH, 3P, MOMENT, BLK - VCB/MC (ON/OFF)	6 NO.		1	VENDOR
41	EMERGENCY STOP PB SWITCH, MAINT TWIST TO UNLOCK -EMR OFF (WITH YELLOW COVER)	5 NC.		1	VENDOR
42	PB SWITCH, MAINTAINED, ILLUM,LAMP - YELLOW - PAS ACK	1 NC.		1	VENDOR
43	PB SWITCH, MOMENT, ILLUM,LAMP - YELLOW - ENS	3 NO.		1	VENDOR
44	PB SWITCH, MOMENT, ILLUM,LAMP - YELLOW - CRUISE CONTROL	2 NO.		1	VENDOR
45	PB SWITCH, MOMENT, ILLUM,LAMP - BLUE - FAULT RESET	2 NO.		1	VENDOR
46	PB SWITCH MAINTAINED ILLUM,LAMP - YELLOW FLASHER (D)	4 NO.		1	VENDOR
47	SHORT LEV, SELECTOR SWITCH 3P MAINT, BLK - PANTO MODE	6 NC.		1	VENDOR
48	PB SWITCH MOMENTARY ILLUM,LAMP RED - ATO ENABLE	1 NO.		1	VENDOR
49	PB SWITCH, MOMENT ILLUM,LAMP, RED - SIGNAL EXCHANGE LIGHT RED (D)	1 NO.		1	VENDOR
50	PB SWITCH, MOMENT LAMP, GREEN - SIGNAL EXCHANGE LIGHT GREEN (D)	1 NO.		1	VENDOR
51	PILOT LAMP, FLUSH, RED - VCD LAMP (D)			1	VENDOR
52	PB SWITCH MOMENT ILLUM,LAMP, YELLOW - SIGNAL BELL (D)	1 NO.		1	VENDOR

**TECHNICAL SPECIFICATION FOR
DRIVER DESK WITH ASCCESSORIES**

DOC. No.: PS4452961-part A, REV No. 00

PROJECT- ICF
Trainsets

SL. NO.	ITEM DESCRIPTION	CONTACT MODULES	MAKE/ PART NO.	Qty. (Nos.)	SCOPE
53	MUSHROOM HEAD PB, YELLOW, MOMENT – HORN LOW TONE (D)	2 NO.		1	VENDOR
54	MUSHROOM HEAD PB, YELLOW, MOMENT – HORN HIGH TONE (D)	2 NO.		1	VENDOR
55	MUSHROOM HEAD PB, RED, MOMENT – VCD ACK (D)	2 NO.		1	VENDOR
56	MUSHROOM HEAD PB RED, MOMENT – VCD RESET	2 NO.		1	VENDOR
57	EMERGENCY STOP PB SWITCH, MAINT, TWIST TO UNLOCK -EMG. BRAKE (D)	2 NO. + 2 NC.		1	VENDOR
58	PILOT LAMP FULSH YLW, - NOT ALL PANTO UP			1	VENDOR
59	PILOT LAMP FULSH YLW, - NOT ALL VCB CLOSED			1	VENDOR
60	PILOT LAMP, FULSH, RED, - EMR BRAKE			1	VENDOR
61	PILOT LAMP, FULSH RED, - EMR OFF			1	VENDOR
62	PILOT LAMP, FULSH RED, – MIN 1 PB APPLIED			1	VENDOR
63	PILOT LAMP, FULSH YLW,- MIN 1 AS FAILED			1	VENDOR
64	PILOT LAMP, FULSH RED, - MIN 1 BRK APPLIED			1	VENDOR
65	PILOT LAMP, FULSH RED, - MIN 1 DOOR OPENED			1	VENDOR
66	PILOT LAMP, FULSH RED, - AC FAULT			1	VENDOR
67	PILOT LAMP, FULSH RED, - SPARE			1	VENDOR
68	PILOT LAMP, FULSH BLUE, - MIN 1 VCB CLOSED			1	VENDOR
69	PILOT LAMP, FULSH BLUE, – RDM			1	VENDOR
70	PILOT LAMP, FULSH GREEN, - OHE AVAILABLE			1	VENDOR
71	PILOT LAMP, FULSH GREEN, - ALL DOORS CLOSED			1	VENDOR
72	PILOT LAMP, FULSH YLW, - SINGLE UNIT OPERATION			1	VENDOR
73	PILOT LAMP, FULSH RED, - TCN FAILURE			1	VENDOR
74	KEY SWITCH ACTUATOR 2P - MODE SELECTOR (NORMAL/SHUNTING)	3 NO.		1	VENDOR
75	SHORT LEV, SLELCTOR SWITCH, 3P, MAINT, BLK - TE/BE (33%, 67% & 100%)	3 NO. + 1 NC.		1	VENDOR
76	SHORT LEV, SLECTOR SWITCH, 3P, MAINT BLK - DIRECTION SELECTION (FWD, 0 , REV)	2 NO. + 2 NC.		1	VENDOR
77	PB SWITCH MAINTAINED, ILLUM, LAMP YELLOW – SPEED LIMIT	2 NO.		1	VENDOR
78	PB SWITCH, MOMENT, ILLUM, LAMP RED – BRAKE	7 NO.		1	VENDOR

**TECHNICAL SPECIFICATION FOR
DRIVER DESK WITH ASCCESSORIES**

DOC. No.: PS4452961-part A, REV No. 00

PROJECT- ICF
Trainsets

SL. NO.	ITEM DESCRIPTION	CONTACT MODULES	MAKE/ PART NO.	Qty. (Nos.)	SCOPE
79	PB SWITCH, MOMENT, ILLUM, LAMP GREEN – DRIVE	3NO. + 2 NO.		1	VENDOR
80	SHORT LEV. SELECTOR SWITCH, 2P MAINT, BLK– CAB LIGHT (G)	3 NO. + 2 NC.		1	VENDOR
81	PB SWITCH MOMENTARY, ILLUM, LAMP BLUE - LAMP TEST	3 NO.		1	VENDOR
82	SHORT LEV. SLELCTOR SWITCH, MAINT, BLK - SPOT LIGHT(G)	2 NO.		1	VENDOR
83	EMERGENCY STOP PB SWITCH, MAINT, TWIST TO UNLOCK -EMG. BRAKE (G)	2 NO. + 2 NC.		1	VENDOR
84	SHORT LEV. SELECTOR SWITH. 3P, MAINT, BLK - MICROPHONE (TR/PA)	2 NO.		1	VENDOR
85	SHORT LVE. SEL SWITCH, ILLUM, 3P, MOMENT, BLK – LIGHTs ON (50% / 100%)	4 NO.		1	VENDOR
86	SHORT LEV. SLECTOR SWITCH 2P MAINT, BLK MARKER LIGHT RED	2 NO.		1	VENDOR
87	SHORT LEV. SLECTOR SWITCH, 2P, MAINT, BLK – MARKER LIGHT WHITE	2 NO.		1	VENDOR
88	PB SWITCH, MOMENT, LAMP YELLOW – SIGNAL BELL (G)	1 NO.		1	VENDOR
89	PILOT LAMP, FULSH RED - TPWS			1	VENDOR
90	PB SWITCH MAINTAINED, ILLUM, LAMP YELLOW – FLASHER LIGHT (G)	4 NO.		1	VENDOR
91	PILOT LAMP, FULSH RED, - VCD LAMP (G)			3	VENDOR
92	PB SWITCH MOMENT , ILLUM, LAMP GREEN – SIGNAL EXCHANGE LIGHT GREEN (G)	1 NO.		1	VENDOR
93	PB SWITCH, MOMENT, , ILLUM, LAMP RED – SIGNAL EXCHANGE LIGHT RED (G)	1 NO.		1	VENDOR
94	MUSHROOM HEAD PB YELLOW MOMENT - HORN HIGH TONE (G)	1 NO.		1	VENDOR
95	MUSHROOM HEAD PB, YELLOW, MOMENT – HORN LOW TONE (G)	1 NO.		1	VENDOR
96	MUSHROOM HEAD PB RED, MOMENT – VCD ACK (G)	2 NO.		1	VENDOR
97	PILOT LAMP, FULSH BLUE, - MIN 1 PANTO UP			1	VENDOR
98	SHORT LEV. SELECTOR SWITCH, 2P, MAINT, BLK – SPARE	1 NO.		1	VENDOR
99	PILOT LAMP, FULSH RED, - SPARE			1	VENDOR
100	PILOT LAMP, FULSH YELLOW, - SPARE			1	VENDOR
101	PILOT LAMP, FULSH RED, - MIN 1 FD			1	VENDOR
102	PB SWITCH MOMENT, ILLUM LAMP GREEN – DOOR OPEN LEFT1	2 NO. + 1 NC.		1	VENDOR

**TECHNICAL SPECIFICATION FOR
DRIVER DESK WITH ASCCESSORIES**

DOC. No.: PS4452961-part A, REV No. 00

PROJECT- ICF
Trainsets

SL. NO.	ITEM DESCRIPTION	CONTACT MODULES	MAKE/ PART NO.	Qty. (Nos.)	SCOPE
103	PB SWITCH MOMENT, ILLUM LAMP GREEN – DOOR OPEN LEFT2	2 NO. + 1 NC.		1	VENDOR
104	PB SWITCH MOMENT, ILLUM LAMP GREEN – DOOR OPEN RIGHT1	2 NO. + 1 NC.		1	VENDOR
105	PB SWITCH MOMENT , ILLUM LAMP GREEN – DOOR OPEN RIGHT2	2 NO. + 1 NC.		1	VENDOR
106	SHORT LEV. SELECTOR SWITCH, 2P, MAINT, BLK – DOOR ENABLE	2 NO.		1	VENDOR
107	PB SWITCH MOMENT , ILLUM LAMP, BLUE – DOOR CLOSE	2 NO. + 2 NC.		1	VENDOR
108	PILOT LAMP, FULSH YELLOW, - RMPU ON			1	VENDOR
109	SHORT LEV. SEL SWITCH, ILLUM, 3P, MOMENT, BLK – RMPU CONTROL	4 NO.		1	VENDOR
110	SHORT LEV. SEL SWITCH, 3P MOMENT, BLK - PIS RESET	1 NO.		1	VENDOR
111	TIME TABLE HOLDER			2	VENDOR
112	110VAC CHARGING SOCKET			1	VENDOR
113	CONNECTORS				VENDOR
i.	32 PIN Connector			1	VENDOR
ii.	17 PIN+17 PIN Connector			2	VENDOR
iii.	46 Pin Connector			5	VENDOR
iv.	64 Pin connector			1	VENDOR
v.	(Ethernet module /4 module+ 12 pins/ 2 module)			2	VENDOR
114	WAGO TB's				VENDOR
i.	TYPE A			250	VENDOR
ii.	TYPE E			30	VENDOR
iii.	TYPE D			25	VENDOR
115	MAGNETIC VALVE FOR ACTUATION OF PNEUMATIC HORN			2	VENDOR
116	DRIVER SEAT			1	VENDOR
117	GUARD SEAT			1	VENDOR
118	SUN VISOR/SCREEN			1	VENDOR

**TECHNICAL SPECIFICATION FOR
DRIVER DESK WITH ASCCESSORIES**

DOC. No.: PS4452961-part A, REV No. 00

PROJECT- ICF
Trainsets**ANNEXURE-I(B)**
BOM - SPARE ITEMS LIST

SL. NO.	ITEM DESCRIPTION	MAKE/ PART NO.	Qty. (Nos.)	SCOPE
1	VCD SWITCH -FOOT OPERATED		2	VENDOR
2	BUZZER		2	VENDOR
3	SHORT LEV. SELECTOR SWITCH, 2P, MAINT, BLK		10	VENDOR
4	LONG LEV. SELECTOR SWITCH, 3P, MAINT, BLK		2	VENDOR
5	LONG LEV. SELECTOR SWITCH, 3P, MOMENT, BLK		2	VENDOR
6	PB SWITCH, MOMENT, ILLUM, LAMP - BLUE		5	VENDOR
7	PB SWITCH, MOMENT, ILLUM,LAMP - YELLOW		2	VENDOR
8	PB SWITCH MONENTARY ILLUM,LAMP RED		2	VENDOR
9	PB SWITCH, MOMENT LAMP, GREEN		2	VENDOR
10	PB SWITCH, MAINTAINED, ILLUM,LAMP - YELLOW		2	VENDOR
11	WIPER CONTROL SWITCH (BLACK COLOR) 4 POSITION SWITCH		2	VENDOR
12	EMERGENCY STOP PB SWITCH, MAINT TWIST TO UNLOCK(WITH YELLOW COVER)		4	VENDOR
13	MUSHROOM HEAD PB, YELLOW, MOMENT		2	VENDOR
14	MUSHROOM HEAD PB, RED, MOMENT		2	VENDOR
15	PILOT LAMP, FLUSH, RED		4	VENDOR
16	PILOT LAMP FULSH YLW		4	VENDOR
17	PILOT LAMP, FULSH BLUE		4	VENDOR
18	PILOT LAMP, FULSH GREEN		4	VENDOR
19	NO Aux Blocks		15	VENDOR
20	NC Aux Blocks		15	VENDOR

**ANNEXURE-II
TENTATIVE LAYOUT ARRANGEMENT & DESK PANEL DETAILS**

DRIVER DESK OVERVIEW



FIG. 1



**TECHNICAL SPECIFICATION FOR
DRIVER DESK WITH ASCCESSORIES**

DOC. No.: PS4452961-part A, REV No. 00

**PROJECT- ICF
Trainsets**

DRIVER DESK FRONT VIEW

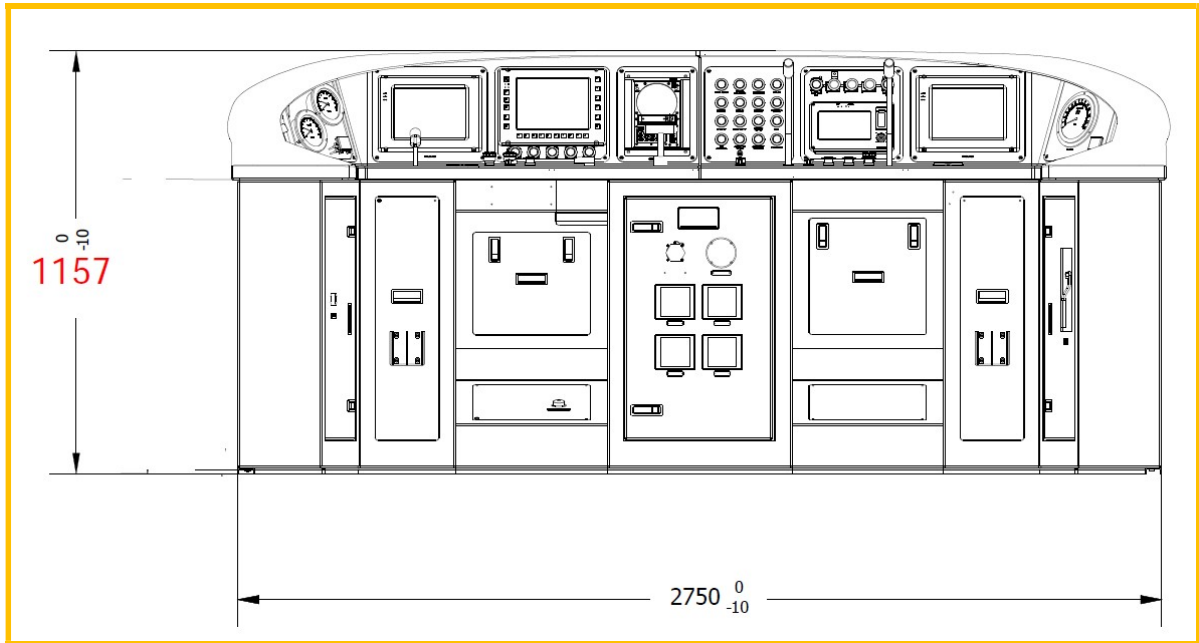

FIG. 2

DRIVER DESK TOP VIEW

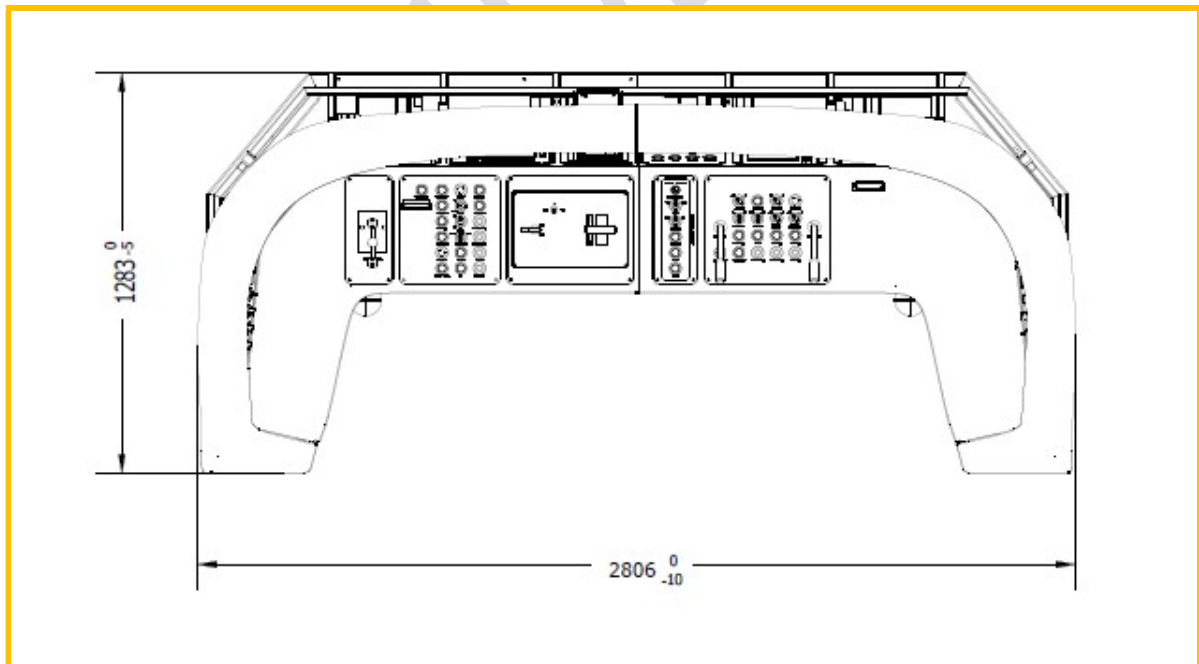

FIG. 3

**Dimensions shown above are indicative only.
Driver's desk dimensions shall be as per UIC 651 standard.**

DRIVER DESK SIDE VIEW

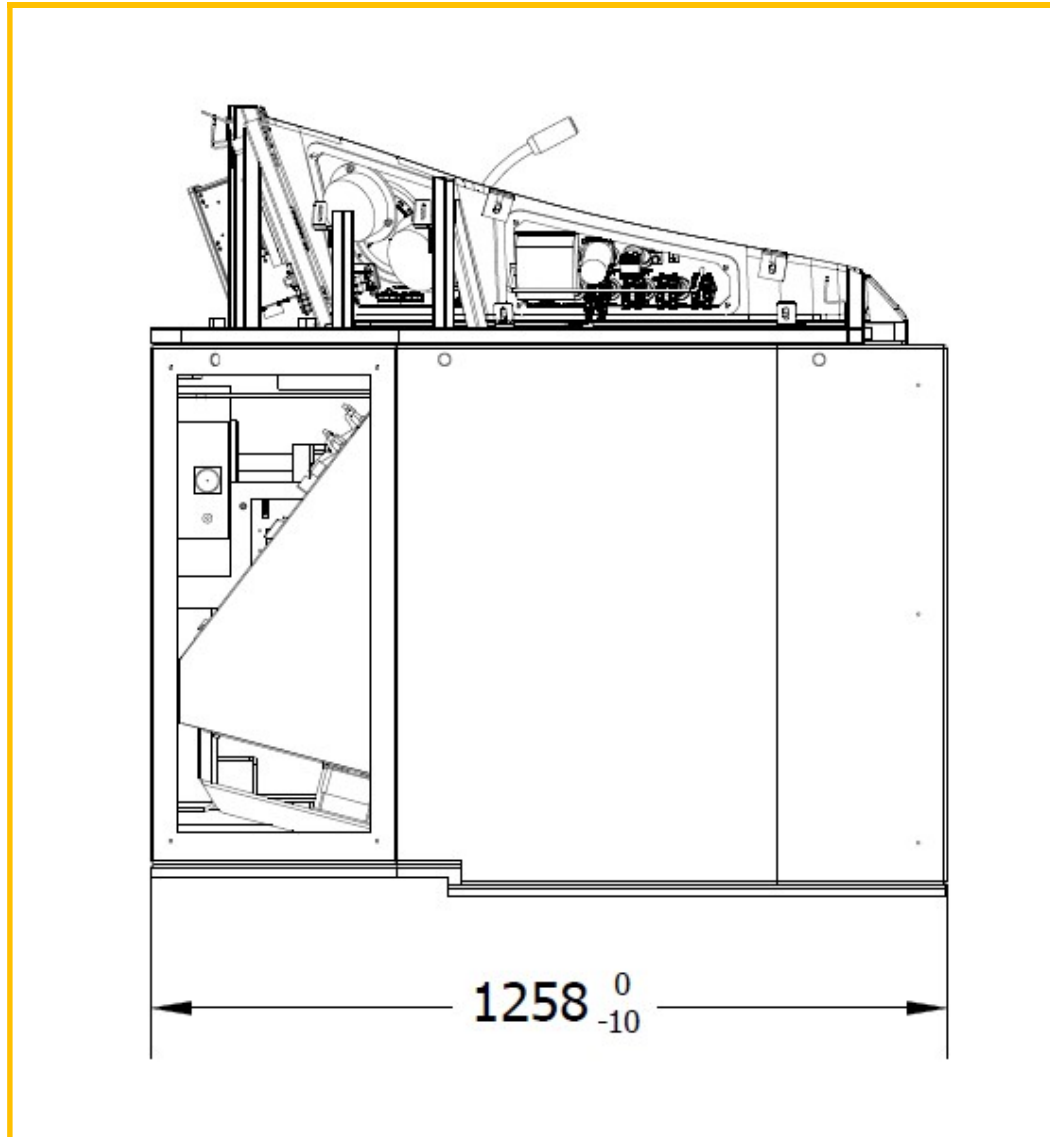

FIG. 4

**Dimensions shown above are indicative only.
Driver's desk dimensions shall be as per UIC 651 standard.**

DRIVER DESK - DRIVER SIDE SWITCH PANEL



FIG.5

DIRVER DESK - DRIVER SIDE SWITCH PANEL



FIG.6

DRIVER DESK – FUNCTIONAL CONTROL PANEL



FIG. 7

DRIVER DESK – SHUNTING OPERATION PANEL

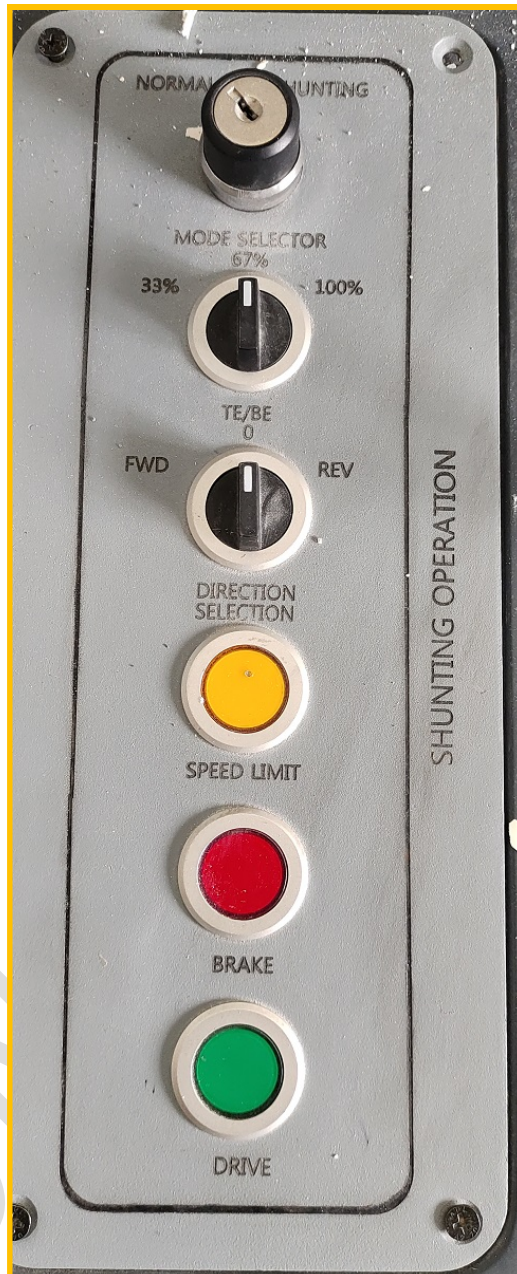

FIG. 8

DRIVER DESK – GUARD SIDE SWITCH PANEL



FIG. 9

DRIVER DESK – TFT DISPLAY-1 (DDU)



FIG. 10

DRIVER DESK – TCAS CONTROL PANEL



FIG. 11

DRIVER DESK – MCP CONTROL & DISPLAY PANEL



FIG. 12

DRIVER DESK – TFT DISPLAY-2 (CCTV HMI)



FIG. 13

SPEED RECORDER CUM INDICATOR



FIG. 14

DRIVER DESK – GUARD SWITCH PANEL



FIG. 15

DRIVER DESK – MASTER CONTROLLER



FIG. 16

DRIVER DESK – AUTO BRAKE CONTROLLER

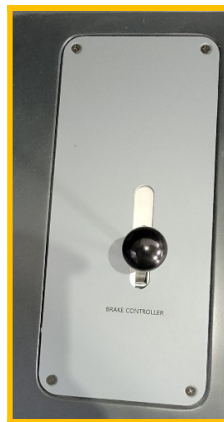

FIG. 17

DRIVER DESK – MR-BP & BC-AR GAUGE DRIVER SIDE PANEL



FIG. 18

DRIVER DESK – BP GAUGE GUARD SIDE PANEL



FIG. 19

**DRIVER DESK – BUZZER, TCAS ALARM AND
CHARGING SOCKET PANEL**



FIG. 20

DRIVER DESK – FOOT OPERATED VCD SWITCH



FIG. 21

DRIVER DESK – TCAS EMR ISO COCK (DRIVER SIDE PANEL)



FIG. 22

DRIVER DESK – EMERGENCY BRAKE (GUARD SIDE PANEL)



FIG. 23

**ANNEXURE-III
DRIVER SEAT REFERENCE GA DRAWING**

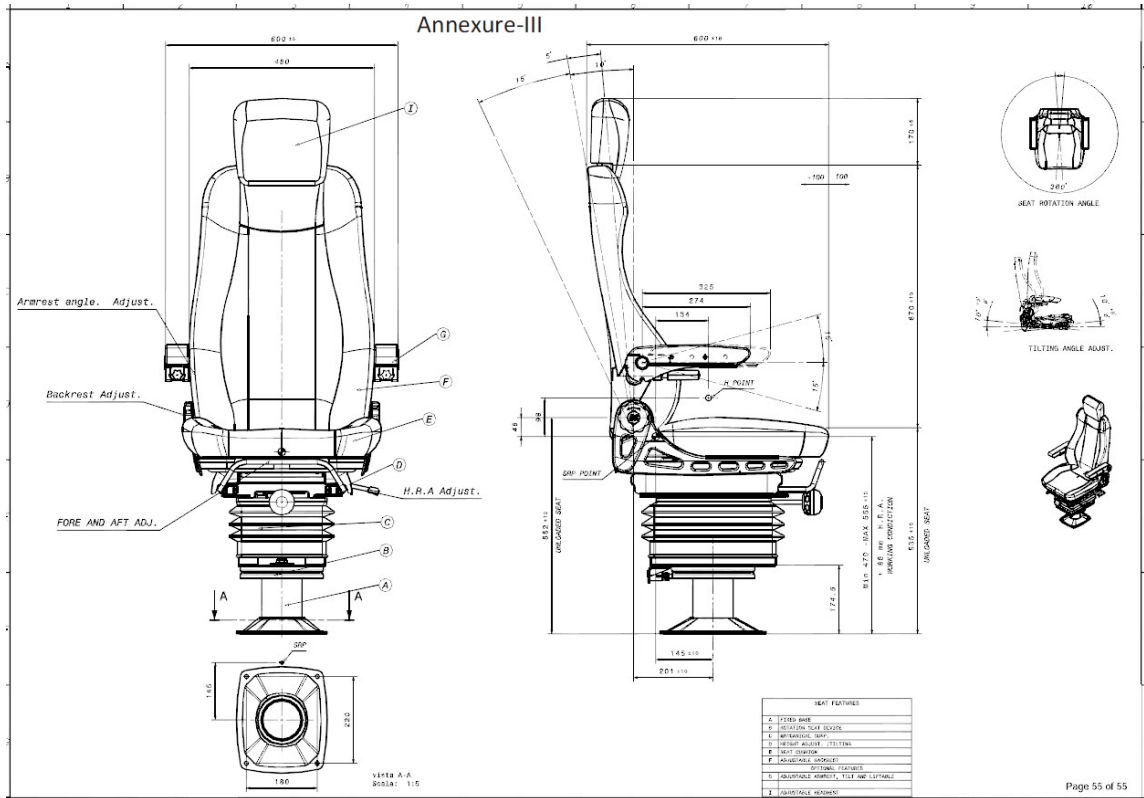



ANNEXURE-IV

SUN VISOR REFERENCE DRAWING

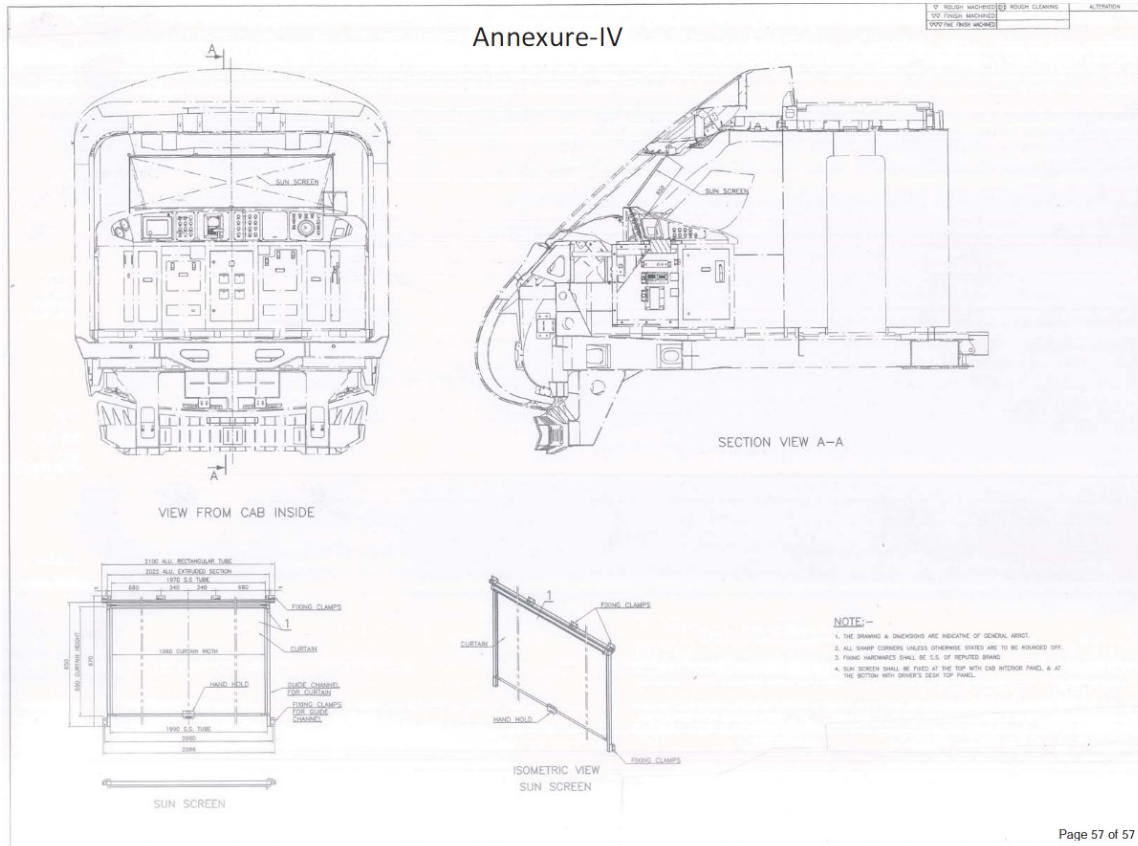

	TECHNICAL SPECIFICATION FOR DRIVER DESK WITH ASCCESSORIES	PROJECT- ICF Trainsets
	DOC. No.: PS4452961-part A, REV No. 00	

PERFORMA FOR PERFORMANCE CERTIFICATE

Name of firm:

TO WHOMSOEVER IT MAY CONCERN

Sub : Confirmation letter for service performance

Dear Sir,

We hereby confirm that We have manufactured _____ number of sets of(Name of Equipment with Model No.) for 3 Phase IGBT based EMUs/MEMUs/Metros/trainsets/LOCOs.

We further confirm that number of sets of(Name of Equipment with Model No.) for 3 Phase IGBT based EMUs/ MEMUs/Metros/trainsets/Locos are in satisfactory operation for railway rolling stock application.

Proforma for performance statement confirming above is also attached.

Yours faithfully

For (Name of Firm)

CONFIDENTIAL

	TECHNICAL SPECIFICATION FOR DRIVER DESK WITH ASCCESSORIES	PROJECT- ICF Trainsets
	DOC. No.: PS4452961-part A, REV No. 00	

REVISION HISTORY

Rev No.	Date	Description/Update

CONFIDENTIAL