	BHARAT HEAVY ELECTRICALS LIMITED (A GOVT OF INDIA UNDERTAKING)	Water Systems Group- WEG & WS Boiler Auxiliary Plant (BAP), Ranipet
---	---	--

TECHNICAL SPECIFICATION FOR SLURRY PUMPS

SPECIFICATION NUMBER : ROS: 9094: 00
BUYER (EPC) : BHEL, BAP Ranipet
APPLICATION : FLUE GAS DESULPHURIZATION SYSTEM

		<i>A. Kumar</i>	<i>J. M. Ramesh</i>	<i>M. Salaimanalan</i> 210722
Fresh Issue	21.07.2022	Abhinav Kumar	IMRL Rao	M. Salaimanalan
REV	Date	Prepared	Checked	Approved

This document is meant for the exclusive purpose of bidding against this specification and shall not be transferred, reproduced or otherwise used for purposes other than that for which it is specifically issued.



TECHNICAL SPECIFICATION OF SLURRY PUMPS

ROS:9094:00

CONTENTS

1.0	INTENT OF SPECIFICATION
2.0	APPLICABLE CODES & REGULATIONS
3.0	PROVENNESS CRITERIA
4.0	MATERIAL OF CONSTRUCTION
5.0	SCOPE OF SUPPLY
6.0	DESIGN & CONSTRUCTION
7.0	GENERAL REQUIREMENTS
8.0	PACKING & FORWARDING
9.0	SUPERVISION OF ERECTION, TESTING & COMMISSIONING
10.0	EXCLUSION
11.0	INSPECTION AND TESTING
12.0	PAINTING
13.0	SPARES, TOOLS & TACKLES
14.0	PERFORMANCE GUARANTEE
15.0	BID EVALUATION CRITERIA FOR POWER CONSUMPTION
16.0	LIQUIDATED DAMAGES FOR POWER CONSUMPTION
17.0	WARRANTY
18.0	FIRST FILL OF CONSUMABLES
19.0	TRAINING
20.0	CONFLICT
21.0	DOCUMENTATION
22.0	LIST OF TESTS
	ANNEXURES-I, II, ANNEXURES-A to K (As Applicable)



TECHNICAL SPECIFICATION OF SLURRY PUMPS

ROS:9094:00

1.0 INTENT OF SPECIFICATION

This specification covers the minimum requirements for the complete design, material, manufacturing, shop inspection, testing at the manufacturer's works, supervision of erection & commissioning and performance guarantee testing for the Flue Gas Desulphurization plant. For project specific technical parameters, refer to **Annexure-A**. The following points may be noted:

- a. Bidder shall assume full responsibility for the entire equipment assembly and shall comply to the requirements of this specification and referred specifications/attachments to enquiry/order.
- b. In case, deviations are considered essential by the Bidder (after exhausting all possible efforts), the same shall be separately listed in the Bidder's proposal under separate section, titled as "List of Deviations/Exceptions to the Enquiry Document (**Annexure- II**)".
- c. Any deviation, not listed in Annexure - II, though reflected in any other part of the offer, shall not be considered.
- d. BHEL discretion is final in acceptance / rejection of exceptions / deviations listed by Bidders' proposal in Annexure – II. Only written approval by BHEL is valid means of acceptance of deviation / exception.
- e. Compliance to this specification shall not relieve the Bidder of the responsibility of furnishing equipment and accessories/auxiliaries of proper design, materials and workmanship to meet the specified start up and operating conditions.
- f. In case, the Bidder considers requirement of additional instrumentation, controls, safety devices and any other accessories/auxiliaries essential for safe and satisfactory operation of the equipment, the same shall be recommended along with reasons in a separate section and include the same in scope of supply.
- g. All accessories, items of work, though not indicated but required to make the system complete for its safe, efficient, reliable and trouble free operation and maintenance shall also be in supplier's scope unless specifically excluded.

2.0 APPLICABLE CODES & REGULATIONS

The design and materials shall conform to the requirements of applicable codes and regulations of the latest edition. The design, manufacture, installation and testing of the pump shall follow the latest applicable Indian/International (ASME/EN/Japanese) Standards. In general, pumps shall conform to latest edition of the following standards:

- IS:1520: Horizontal centrifugal pumps for clear cold fresh water
- IS:5120: Technical requirements of roto dynamic special purpose pumps
- API:610: Centrifugal pumps for general refinery service
- IS:5639: Pumps handling chemicals & corrosion liquids
- IS:5659: Pumps for process water
- HIS: Hydraulic Institute Standards USA
- ANSI HI 12.1 to 12.6 & ISO 9906 2012 grade 2B standard (Pump Testing)

3.0 PROVENNESS CRITERIA: IF APPLICABLE

Bidders shall meet the Qualification Requirement (QR) for Slurry Pumps as per **Annexure-B** and **submit the Annexure to qualification requirement (Attachment-3K)**. Necessary documentary evidences shall be submitted along with the bid. **Offers of Bidders not meeting Qualification Criteria shall not be considered for evaluation.**



TECHNICAL SPECIFICATION OF SLURRY PUMPS

ROS:9094:00

4.0 MATERIAL OF CONSTRUCTION

	Material of construction	Horizontal Centrifugal Pumps	Vertical Sump Pumps
i.	Casing	1. Ductile Iron (65-45-12, ASTM A536)+ Replaceable Rubber Liner OR Ductile Iron (65-45-12, ASTM A536)+ Replaceable Hi-chrome Liner OR Complete High Chrome Casing. 2. Casing with liner - 14000hrs to be guaranteed. OR 3. In case of Hi chrome casing pump the Guaranteed wear life of casing shall not be less than 24000 hrs.	1. Ductile Iron (65-45-12, ASTM A536)+ Replaceable Rubber Liner OR Ductile Iron (65-45-12, ASTM A536)+ Replaceable Hi-chrome Liner OR Complete High Chrome Casing. 2. Casing with liner - 14000hrs to be guaranteed. 3. In case of Hi chrome casing pump the Guaranteed wear life of casing shall not be less than 24000 hrs.
ii.	Impeller	Hi-chrome with 14000 hrs. guarantee.	C.S/C.I + Rubber Liner, Complete Hi Chrome with 14000 hrs. guarantee.
iii.	Solid Shaft + Sleeve	Duplex SS 2205 /EN8D /EN9 or any other superior material suitable for slurry application + sleeve made of CD4M Cu ASTM A-743 (Duplex Stainless Steel).	Duplex SS 2205 / EN8+Rubber Lined or any other superior material suitable for slurry application. sleeve made of CD4M Cu ASTM A-743 (Duplex Stainless Steel).
iv.	Base Plate	Carbon steel with Epoxy Coating	Carbon steel with Epoxy Coating

Note: The material and thickness of the liners shall ensure a minimum service life of 2 years before replacement.

The time period for warranty/ guarantee of the wear life /service life will be considered whichever is later for the above MOC details.

5.0 SCOPE OF SUPPLY

Scope for the bidders shall include Design, Supply and Supervision of Erection & Commissioning.

Design: Includes basic engineering, detail engineering, preparation and submission of engineering drawings/calculations/datasheets/quality assurance documents/field quality plans, storage instructions, commissioning procedures, operation & maintenance manuals, performance guarantee test procedures and assisting BHEL in obtaining time bound approval from CUSTOMER.

Supply: Includes manufacturing/fabrication, shop floor testing, stage inspections, final inspections, painting & packing.

Supervision of Erection & commissioning: Includes supervision of erection & commissioning, supervision of trial operation, training of customer's O&M Personnel.

The scope of supply for Slurry pump shall include but not limited to the following:



TECHNICAL SPECIFICATION OF SLURRY PUMPS

ROS:9094:00

Sl. No	Scope
1.	Slurry pump complete with
	i. Casing
	ii. Rotor and Shaft assembly
	iii. Drive motor as per specification
	iv. Coupling or Pulley & V-belt (As applicable)
	v. Common base frame for pump & motor and shock pads
	vi. Single/ Double Mechanical seal as applicable with applicable Quenching/ Flushing plan
	vii. Flushing/Quenching and drain system Provision to be provided in mechanical seal in case of with Flushing/Quenching mechanical seal along with applicable API Plans. Water flow and pressure requirement to be duly mentioned while bid submission. Suitable Pressure Relief Valve to be considered & same should be a part of API Plan 62.
	viii. Coupling guards with bolts or V-belt guard (As applicable)
	ix. Discharge pressure guage(to be supplied as loose)
	x. Temporary Strainers required for commissioning
	xi. Expansion joints (Bellows) at suction and Discharge
	xii. Casing drain terminated at battery limit with flange(if applicable)
	xiii. Cooling water piping for Bearing cooling(as applicable)
	xiv. Lubrication system (as applicable)
	xv. Foundation bolts for supplied items
	xvi. Pedestal for Pump(as applicable)
	xvii. Drip tray for drainage collection from pump (if applicable). However bidder to provide the same in case end customer requests for the same.
	xviii. Lantern Ring (if applicable)
	xix. Mechanical Running and Performance test at shop
	xx. Painting and Rust Prevention during shipment and construction
	xxi. Supervision of Erection & commissioning at site.
	xxii. Special tools & tackles as applicable.
	xxiii. Accessory (Internal) Piping within the skid(if applicable)
	xxiv. First fill of consumables like lubricants, etc.,
	xxv. Start-up & Commissioning & Mandatory spares.
	xxvi. Seaworthy Packing & Forwarding (for import supplies) to Project Site office
	xxvii. Installation, operation and maintenance manuals
	xxviii. In case of series pumps, common individual base frame to be provided by vendor with interconnecting piping (MOC: MSRL/ any other material suitable for handling slurry application), interconnecting expansion joints, interconnecting fasteners.
	xxix. Any other items required for completeness of the equipment except the items covered in the exclusions.

6.0	DESIGN & CONSTRUCTION
6.1	DESIGN REQUIREMENTS
1.	The pump shall be single stage centrifugal type capable of delivering the rated flow at rated head with margins as specified below.





TECHNICAL SPECIFICATION OF SLURRY PUMPS

ROS:9094:00

2.	<p>All slurry pumps for a particular service shall be identical and interchangeable. The composition of Limestone slurry is provided in the Annexure for reference. Bidder shall consider the Slurry pumps accordingly with reference to construction and speed as follows.</p> <p>Tip speed of impeller : (a) for rubber lined pumps should not exceed 25m/sec, (b) for other pumps should not exceed 30m/sec- vendor to furnish the same in its offer.</p> <p>However, if the discharge head exceeds 6.0 bar bidder may consider higher tip speed subject with BHEL approval. The slurry velocity shall be in the range of 1.2 m/s to 2.3 m/s to prevent bed of solids in the pipe. Notwithstanding the above parameters, it shall be the bidders endeavor and responsibility to ensure that there shall be no settling of solids in the pipelines. Necessary calculations shall be submitted to BHEL for review.</p>									
3.	All the pump wear parts in contact with the slurry shall be provided with replaceable rubber/elastomer liners suitable for the fluid handled. The bidder can also offer a hi-chrome alloy lined pump if the bidder has previous experience of the same for similar applications.									
4.	The pump shall be provided with seals of proven type and shall be designed for minimization of seal water consumption. The shaft shall be supported on heavy duty ball/roller bearings(FAG/SKF/TIMKEN/ or equivalent subjected to BHEL approval)									
5.	The Pump shall be capable of developing the required total head at rated capacity for continuous operation. Also the pumps shall be capable of being operated to give satisfactory performance at any point on the HQ characteristics curve. Bidder to confirm the pump operating range from 40% to 120% with respect to Duty Point of the quoted pump. Bidder to quote higher efficiency pumps based on the rated duty condition mentioned in the specifications. Rated Flow shall be within the region of 90% to 110 % of the best efficiency flow rate of the pump									
6.	The total head capacity curve shall be continuously rising from the operating point towards shut-off without any zone of instability and with a minimum shut-off head of about 15% more than the design head.									
7.	Pumps of a particular category shall be identical and shall be suitable for parallel operation with equal load division. The head Vs capacity and BHP Vs capacity characteristics should match to ensure even load sharing and trouble free operation throughout the range. Components of identical pumps shall be interchangeable.									
8.	<p>Pumps shall run smoothly without undue noise and vibration. Peak to peak vibration limits shall be restricted to the following values during operation. Pump RPM shall be designed with respect to allowable pump tip speed and selected material of construction for pump impeller in Clause 6.1(2) above.</p> <table border="1" style="width: 100%; border-collapse: collapse;"> <thead> <tr> <th style="width: 33%;">Speed</th> <th style="width: 33%;">Antifriction Bearing</th> <th style="width: 33%;">Sleeve Bearing</th> </tr> </thead> <tbody> <tr> <td>1500 rpm and below</td> <td>75.0 micron</td> <td>75.0 micron</td> </tr> <tr> <td>3000 rpm</td> <td>50.0 micron</td> <td>65.0 micron</td> </tr> </tbody> </table> <p>The noise level shall not exceed 85 dBA overall sound pressure level reference 0.0002 microbar (the standard pressure reference for air sound measurement) at a distance of 1 M from the equipment surface.</p>	Speed	Antifriction Bearing	Sleeve Bearing	1500 rpm and below	75.0 micron	75.0 micron	3000 rpm	50.0 micron	65.0 micron
Speed	Antifriction Bearing	Sleeve Bearing								
1500 rpm and below	75.0 micron	75.0 micron								
3000 rpm	50.0 micron	65.0 micron								
9.	The pumps shall be capable of starting with discharge valve fully open and close condition. Motors shall be selected to suit to the above requirements. Continuous Motor rating (at 50 deg.C ambient) shall be at least ten percent (10%) above the maximum load demand of the pump in the entire operating range to take care of the system frequency variation and no case less than the maximum power Requirement at any condition of the entire characteristic curve of the pump.									

 TECHNICAL SPECIFICATION OF SLURRY PUMPS	
ROS:9094:00	
10.	The kW rating of the drive unit shall be based on continuously driving the connected equipment for the conditions specified. However, in cases where parallel operation of the pumps are specified, the actual motor rating is to be selected by the Bidder considering overloading of the pumps in the event of tripping of operating pump(s).
11.	Pumps shall be so designed that pump impellers and other accessories of the pumps are not damaged due to flow reversal.
12.	The Contractor under this specification shall take full responsibility in the operation of pump and motor as a unit.
13.	The pumps shall be designed as impeller centrifugal pump. The pumps shall be wear-resistant, be equipped with flushing devices/provision to prevent sedimentation and shall be designed and installed in a manner to allow easy replacements, repair and maintenance.
14.	Impellers shall be single piece casting. Fabricated impellers shall not be accepted.
15.	The slurry pumps shall be equipped with oil level indication (if applicable), coupling guard/V-belt guard & other accessories for collecting leakage, made of corrosion resistant material.
16.	Pumps must be carefully set to ensure that the net positive suction head available under all operating conditions will be adequate. The NPSH Values are to be referred to the least favorable operating conditions- lowest atmospheric pressure, lowest level of water on the suction side of the pump and highest temperature of the pumped fluid. An adequate safety margin of normally greater than 1m to the max NPSH required shall be provided.
17.	All pumps shall be fitted with pressure gauges on discharge end. (To be supplied loose). The technical detail for the Pressure Gauge is specified elsewhere in the BHEL specification.
18.	Venting valve shall be fitted to all pumps at suitable points on the pump casing unless the pump is self-venting due to the arrangement of the suction and discharge nozzles. Drainage facilities shall be provided on the pump casing or adjacent pipe work to facilitate the dismantling of pumps. (If Applicable)
19.	Pumps shall have stable head-capacity characteristics curve from run-off to shut-off.
20.	Selection of Duty point should be nearest to BEP (Best Efficiency Point). It should be noted that head variation is due to level variation in tank. Pump has to run in the system without compromising it's NPSH requirement at lowest water level in tank. Hence, when tanks are filled-up and at normal water level, pump will operate at the right of BEP. Pump's operating zone shall be considered accordingly. The maximum efficiency of pump shall be within $\pm 10\%$ of the rated design flow as indicated in data sheets.
21.	External flushing is required to remove the accumulated particles within the pump & provision for the same should be provided in order to remove the accumulated particles within the pump, all related information shall be mentioned in data sheet. Bidder to supply quenching plan system mounted on the pump base frame as per API plan and water requirement to be defined while submitting the bid.
22.	Pump should have adjustment provision of axial clearance between casing and impeller for maintenance of performance at best efficiency in the event of wear between impeller and casing.
23.	Each pump will have a coupling of adequate size, designed for full load and capable of supporting start-up an overload moment. Each half of the coupling will be factory mounted and locked to its shaft. The coupling must be able to accept the adjustment of the impeller. Bidder can also quote pumps with V-belt & Pulley arrangement.
24.	The Antifriction bearing of the pumps shall be designed for minimum useful life (L-10) of 20,000 hours of continuous operation (Under the design condition). The thrust bearing will have dimensions for a minimum of 175 % of the required load.
25.	The pumps shall have mechanical seals of cartridge type with self-lubrication sliding ring cartridges. The static part will be mounted on the seal plate with circumferential ring (O-ring) or another flexible sealing ring. Built in seal design will not be accepted.

 TECHNICAL SPECIFICATION OF SLURRY PUMPS	
ROS:9094:00	
26.	The sealing areas shall be designed in such a way so that solids do not precipitate, affect the cooling, or affect adjustment and mechanical functioning of the seals. Seals requiring jet cleaning shall be avoided. Bidder to furnish the water requirement for Plan 62 so that BHEL can arrange the same suitably.
27.	Pump induced vibration due to flow pulsations shall be avoided through suitable design.
28.	Each rotating equipment shall be first statically balanced and then dynamically balanced according to ISO 1940 Gr 6.3 (As applicable.).Moreover Bidder to ensure balancing of the impellers after mounting on the shaft as per relevant balancing standards. In case during operation deflection in the shaft or any other operation issues occur, the same needs to be rectified by the bidder without any price implication to BHEL.
6.2	CONSTRUCTIONAL FEATURES
A)	CASING
a.	Pumps shall be of Radial Split Casing (if twin casing pump), Over-hang, End Suction Type Back Pull-out design, Vertical Discharge type for Horizontal Centrifugal Pump.
b.	The casing shall be designed to withstand the maximum shut-off pressure developed by the pump at the pumping temperature.
c.	Pump casing shall be provided with a vent connection and piping with fittings & valves. Casing drain as required shall be provided complete with drain valves, piping and plugs (As Applicable).
d.	Pump casing to be provided with a connection for discharge pressure gauge as standard feature. (Pressure Gauge shall be supplied loose) It shall be structurally sound to provide housing for the pump assembly and shall be designed hydraulically to minimum radial load at part load operation.
e.	For single casing pumps, bidder to confirm that in case casing wears out by 50% during operation, pump allowable maximum pressure will not reduce. This shall be confirmed strictly for equipment and plant safety. A basis of calculation proving the same shall be submitted for review.
f.	Lifting provision of pump as a whole and individual casing half should be provided.
g.	Renewable wear rings (As applicable) shall be provided at points of running clearance and shall be made from appropriate materials indicated in the referred standards.
B)	IMPELLER
a.	Impeller shall be semi-closed, closed or open type and designed in conformance with the detailed analysis of the liquid being handled. The impeller shall be secured to the shaft, and shall be retained against circumferential movement by keying, pinning or lock rings. On pumps with overhung shaft, impellers shall be secured to the shaft by a lockout or cap screw which tightness in the direction of normal rotation. Bidder may also propose threaded connection between impeller and shaft. Bidder shall provide evidence of zero contact between the slurry being processed and the Threaded region.
b.	Tipspeed of impeller: Please refer Clause 6.1(2)
c.	Miller number for the material should be justified for that pumping medium as per ASTM G75-95 as well as the corrosion effect of pumping medium
d.	Impeller as rotating assembly along with all elements should meet balancing standard of ISO 1940 Gr 6.3

	
TECHNICAL SPECIFICATION OF SLURRY PUMPS	
ROS:9094:00	
e.	Maximum size impellers for the pump body shall not be quoted. By installation of a new impeller a head increase of 5% minimum shall be possible. Maximum size impeller to be quoted or as appropriate technically by the bidder. In case there is variation required in the system then same can be done thru by changing the pump RPM with change in pulley ratio.
C)	IMPELLER/CASING WEARING RINGS
a.	Replaceable type wearing rings shall be provided at suitable locations of pumps. Suitable method of locking the wearing ring shall be used. Wearing rings shall be provided in pump casing and/or impeller as per manufacturer's standard practice.
D)	SHAFT
b.	The shaft shall be ground and polished to final dimensions and shall be adequately sized to withstand all stresses from rotor weight, hydraulic loads, vibration and torques coming in during operation.
c.	All Pump shafts shall be of ample size to transmit the maximum possible output from the prime mover.
d.	The pump shaft and coupling are to be so dimensioned that the maximum permissible torque of the shaft is higher than the maximum transmissible torque of the coupling and gear.
e.	Pumps shall operate smoothly throughout the speed range up to their operating speeds. The critical speed shall be well away from the operating speed and in no case less than 130% of the rated speed.. The determination of the shaft diameter and the distance between two consecutive bearings must include a sufficiently large safety margin to satisfy this condition.
f.	Shafts shall be conservatively designed to transmit maximum power required and to assure rigidity. Shafts shall be machined and ground to close tolerances and shall be tapered to permit easy removal of the seals and bearings.
g.	Shaft shall run in high precision heavy duty roller bearings. Lubrication system provided shall be such that visual checking of lubricant level is possible
h.	No parts of the shaft should come in contact with the liquid medium for horizontal centrifugal pump.
i.	Shaft should have a keyed joint at impeller hub or thread connection between impeller and shaft is acceptable however in no circumstances Slurry shall come in contact with the threaded part.
E)	SHAFT SLEEVES
a.	Renewable type fine finished shaft sleeves shall be provided at the stuffing boxes/mechanical seals. Length of the shaft sleeves must extend beyond the outer faces of gland packing of seal end plates so as to distinguish between the leakage between shaft and shaft sleeve and that past the seals/gland. Shaft sleeves shall be fastened to the shaft to prevent any leakage or loosening. Shaft and shaft sleeve assembly should ensure concentric rotation.
F)	BEARINGS
a.	Heavy duty bearings, adequately designed for the type of service specified in the enclosed pump data sheet and for long, trouble free operation shall be furnished. Proper lubricating arrangement for the bearings shall be provided. The design shall be such that the bearing lubricating element does not contaminate the liquid pumped. Where there is a possibility of liquid entering the bearings suitable arrangement in the form of deflectors or any other suitable arrangement must be provided ahead of bearings assembly. Bearings shall be easily accessible without disturbing the pump assembly. A drain plug shall be provided at the bottom of each bearings housing.

 TECHNICAL SPECIFICATION OF SLURRY PUMPS	
ROS:9094:00	
b.	The bearings may be ball, roller or sleeve bearing. The bearings offered shall be capable of taking both the radial and axial thrust coming into play during operation. If sleeve bearings are used these shall be machined for close running fit. In case, sleeve bearings are offered additional thrust bearings shall be provided. The bearings shall be designed to take the necessary radial load as well as the net axial thrust. Bearings shall be lubricated properly and sized for an operating life of 20,000 hours on the basis of maximum axial and radial loads and rated speed. Oil level indication shall be provided.
c.	Bearing housings on horizontal shaft pumps shall be designed to enable the bearings to be replaced without removing the pump or motor from its mounting. Bearing housings on horizontal shaft pumps shall be effectively protected against the ingress of water, pumped fluid and dust by suitable nonferrous deflectors.
d.	If bearing housing requires cooling water, volume and pressure of cooling water is to be indicated in Technical Data Sheet.
e.	Lubricating oil will be the responsibility of pump manufacturer. Hence, manufacturer has to make arrangement of first fill of oil at installation, and at commissioning stage. Quantity of oil and its grade is to be indicated in Drawing and Operation Manual.
f.	Make of Bearings : SKF, FAG & TIMKEN or any other reputed make subjected to BHEL approval.
G)	MECHANICAL SEALS
a.	Mechanical seals shall be of single/double type with either sliding gasket or bellows between the axially moving face and shaft sleeves or any other suitable type. The sealing faces should be highly lapped surfaces of materials known for their low frictional coefficient and resistance to corrosion against the liquid being pumped.
b.	The pump supplier shall coordinate with the seal maker in establishing the seal chamber of circulation rate for maintaining a stable film at the seal face. The seal piping system shall form an integral part of the pump assembly. For the seals under vacuum service, the seal design must ensure sealing against atmospheric pressure even when the pumps are not operating. Necessary provision for seal water supply along with complete piping fittings and valves as required shall form integral part of pump supply. Bidder to supply quenching plan system mounted on the pump base frame as per API plan and water requirement to be defined while submitting the bid.
c.	The Mechanical Seals shall be so arranged that repacking or fitting of replacement seals can be carried out with the minimum of disruption to plant operation.
d.	Design the mechanical seals chamber to have sufficient room to lubricate and get seal face cool with its own slurry.
e.	Provide requirements for periodical flushing to rinse the seal face for leaked slurry.
f.	Pump shall be supplied with mechanical seal. All mechanical seals, regardless of type or arrangement, shall be of the cartridge design. Hook sleeve cartridge should not be used.
g.	Requirement of flushing/quenching water, its quantity, and pressure to be indicated in data sheet.
h.	Slurry Pumps should have Zero leakage. However, quantity of leakage, if it is unavoidable, pump should have a provision of collecting of any drip leakage and flushing the same to nearby pit is to be providing without corroding the base plate of pump.
i.	Mechanical seals shall be fitted and installed in the pump before shipment and shall be clean. Mechanical seals shall be plugged with screw for shipping.

 TECHNICAL SPECIFICATION OF SLURRY PUMPS	
ROS:9094:00	
j.	Seal life shall be guaranteed for 14000 hrs. In the event seals fail before guarantee period, the bidder shall replace the same without any cost implication. Make of Mechanical Seals: Eagle Burgmann/ Flowserve/ John crane / any other make subjected to BHEL approval.
k.	All the mechanical seal shall have a lubrication arrangement i.e. Quenching (Plan 62) only. Bidder shall guarantee the seal life with quenching itself.
l.	For Quenching integrated piping along with their respective instruments, fittings will be in the scope of the bidder. The Quenching plans should meet the respective API Standards. Bidder to provide the quantity of water requirement for such arrangement so that BHEL can arrange the same suitably.
m.	BHEL will provide pressure in the range of (1-4) bar for Quenching requirement. Bidder to necessarily consider PRV to meet the API Plan 62 requirement.
n.	Bidder may kindly note the ports for Quenching & Flushing (if available) should be separate & same should be tightly sealed in case of non-usage.
H)	COUPLING (if applicable)
a.	The pump and motor shafts shall be connected with an adequately sized flexible coupling of proven design with a spacer to facilitate dismantling of the pump without disturbing the motor. Necessary coupling guards shall also be provided.
b.	Coupling halves shall be machine matched to ensure accurate alignment. Couplings and gears must have a rated capacity of at least 120% of the maximum potential power transmission requirement.
c.	Coupling shall be of flexible type made of cast steel. The Bidder shall furnish both halves of the coupling. Both the Coupling halves shall be bored and keyed to fit shafts of the gearbox and the motor by bidder.
d.	All rotating parts such as coupling shall be covered with suitable protective guards. Guards shall be easily removable type. If weight of the coupling is heavy (>40 kgs), provision of tapped hole should be incorporated in right place of hub to handle the same effortlessly.
I)	BASE PLATE
a.	A common base plate mounting both for the pump and motor shall be furnished. The base plate shall be fabricated steel and of rigid construction, suitably ribbed and reinforced. Base plate and pump supports shall be so constructed and the piping unit so mounted as to minimize misalignment caused by mechanical forces such as normal piping strain, internal differential thermal expansion and hydraulic piping thrust. Suitable drain troughs and drip lip shall be provided. The HT motors are in BHEL's scope. However, bidder should design the base frame in order to accommodate both the HT motor & pump on the same base frame. (HT motor overall dimensions & weight will be provided by BHEL after placement of PO).
b.	Suitable holes shall be provided for grouting and these shall be so located that the base plate can be grouted in place without disturbing the pump and motor.
c.	Base plate must have provision of aligning driver and driven shaft in both directions of base plate so that shafts can be aligned. Similarly, provision must be provided for alignment of shaft in vertical plane.
d.	Pump manufacturer is to supply base plate along with Foundation bolt & Nut, "Taper wedge (if applicable)" and the necessary fastener for Pump and Motor with Base plate.
e.	Base plate must be provided with a trough, material of which must be compatible of pumping liquid. Leaked liquid, collected in trough, can be systematically routed at designated point
f.	Base plate must be stress-relieved for any residual welding stress and certificate to that effect is to be submitted as per inspection requirement.

 TECHNICAL SPECIFICATION OF SLURRY PUMPS	
ROS:9094:00	
J)	STUFFING BOXES
a	Stuffing box design should permit replacement of packing without removing any part other than the gland. Stuffing boxes of packed ring construction type shall be provided wherever specified. Packed ring stuffing boxes shall be properly lubricated and sealed as per service requirements and manufacturer's standards. If external gland sealing is required, it shall be done from the pump discharge. The Bidder shall provide the necessary piping valves, fittings etc. for the gland sealing connection.
K)	ASSEMBLY AND DISMANTLING
a.	Assembly and dismantling of each pump with drive motor shall be possible without disturbing the grouting base plate or alignment.
K)	ADDITIONAL REQUIREMENT FOR VERTICAL SUMP PUMP
a.	The pumps shall be designed for continuous operation. The pump shall be single stage centrifugal type with semi open or open impeller . The pump impeller shall be cantilever type and shall not be supported below the base plate for easy withdrawal.
b.	The pump shall deliver the rated flow at rated head with margins as specified in the respective clauses. The pump shall be capable of pumping of slurry with solid concentration upto 30 wt% & particle lumps of 6-7mm.
c.	The material chosen for the pump components shall be suitable for the fluid handled and shall be proven in similar application.
d.	The pumps shall not be supported below the base plate level for easy withdrawal without entering the sump.
e.	Typical GA Drawing for the vertical pump sumps is attached (Annexure J). The bidder to design the pumps accordingly meeting the minimum & maximum water levels as provided.
M)	ACCESSORIES:
1.	Suction Strainers
i.	Temporary conical strainer to be provided so as to avoid entry of any particle into the pump at the time of commissioning/starting up. Note: Pipe sizes / Flange sizes will be informed during detail engineering with respect to strainer size & its mounting holes.
ii.	Quantity of Temporary Conical Strainers : 1 no. at the suction of each horizontal pump. For the vertical pumps the same is not required.
iii.	MOC & Size of the temporary conical strainers: As per the attached sizing sheet (Annexure K)

6.3 Motor

Please refer to the motor specification attached TECI: LT MOTOR: REV 05(**Annexure-F**). The motor make is subject to end customer approval. The motor painting schedule is subject to customer approval.

Note: 1) All HT Motors are in BHEL Scope.

2) HT Motor Range: Above 200kW.

3) For HT motor pumps, provision for Vibration sensor and Key Phase Marker Sensor should be provided.

a) Vibration Sensor: 4 provisions on the pump. Thread size of M6x1 (M6x1 threaded provision 12mm deep) for each vibration sensor.



TECHNICAL SPECIFICATION OF SLURRY PUMPS

ROS:9094:00

b) Key Phase Marker Sensor: 1 Provision. Notch (of size 30mmL x 15mmW x 3mmD) for phase marker probes are to be provided.

7.0 GENERAL REQUIREMENTS:

S. No.	Description
1.	Metric unit shall be used in the drawings and in the any displays on the equipments. Special attention should be taken that the unit of pressure shall be in dual scales of kPa and kg/cm ² G. For instance the pressure gauges should have dual unit's indication.
2.	Descriptions in the drawings, documents and in the displays shall be in English
3.	All rotating parts such as coupling shall be covered with suitable protective guards. Guards shall be easily removable type.
4.	The equipment shall be designed to withstand the corrosive and moist environment in which these are proposed to operate.
5.	Noise level produced by any rotating equipment individually or collectively shall not exceed 85 dBA measured at a distance of 1.0 meter horizontally from the source in any direction. Predicted sound pressure levels for the pump drive assemblies shall be submitted as part of the proposal data.
6.	The overall vibration level shall be as per ISO 10816 /HIS 9.6.4.11 for casing vibrations.
7.	Suitable drain connections shall be provided (as applicable).
8.	The equipment shall be suitable for stable operation continuously.
9.	Limit of connection: The buyer (BHEL) has an intention to minimize interface for utilities as much as possible. The bidder shall consider this requirement in the planning stage of layout for the equipment. The bidder shall provide the header piping for utilities and branch piping to each nozzle. Terminal points for all utilities shall be located at skid edge. The bidder shall specify all terminal points with tie-in number in the P&ID and submit it in the proposal to confirm the scope of supply.
10.	Corrosion allowance: Corrosion allowance for entire equipment shall be in accordance with latest applicable Indian / International standard.
11.	Flanges shall be in accordance with ANSI B16.5 Class 150, However if Vendor Proposes any other drilling standard, prior approval from BHEL to be taken & Vendor to provide one no. extra pipe fittings such as expansion bellow, concentric reducer/expander etc. for each pump with fasteners suitable for handling slurry application shall be provided by the bidder.
12.	Name plate: All equipment shall be provided with nameplates indicating the item number and service name. Name plates shall be of 304 Stainless steel plate and placed at a readily visible location. Nameplate of main equipment shall have enough information, which will be confirmed during engineering phase. Stainless steel nameplates for all instruments and valves shall be provided.
13.	Rotation arrows shall be cast in or attached with stainless steel plate on each item of rotation equipment at a readily visible location.
14.	Unless otherwise specified, all equipment items where the weight exceeds 15 kg shall be provided with suitable lifting lugs, ears or ring bolts or tapped holes for lifting rings. Minimum shock factor for lifting lugs shall be minimum 2.0. The position of lifting lugs and reference dimension shall be shown on GA and/or outline drawings. NDT shall be conducted for lifting lugs. When any spreader bars are required for lifting and laydown, the bidder shall provide spreader bar with equipment.
15.	Skid Mount/Transportation: Equipment shall be fabricated as skid mount design as much as practical to minimize erection at the site.

 TECHNICAL SPECIFICATION OF SLURRY PUMPS	
ROS:9094:00	
S. No.	Description
16.	Two pieces of stainless steel earth lugs shall be provided with equipment diagonally. The position of earth lugs shall be shown on each GA and/or outline drawing.
17.	Provide double nuts for Foundation bolts.
18.	Bidder shall provide allowable vibration level on foundation in foundation drawings and/or general arrangement drawings.
19.	If the driver/driven equipment train is in the resonance condition or any vibration problems occur, the bidder shall solve the problems in a timely manner.
20.	Bidder shall provide the mating flanges with the necessary gaskets. Gasket Material shall be of EPDM/Neoprene Rubber or any other material suited for slurry application.
21.	All the surfaces of the carbon steel should be rust prevented before shipment for the period of at least 12 months for storage and construction.
22.	Bidder to provide capacity of crane or hoist required for material handling and the details of heaviest component to be handled.
23.	The list of all Bought out items with makes and country of origin to be mentioned along with offer to be submitted.
24.	Quality Plan to be submitted along with the offer.
25.	Minor Chipping i.e. up to 50 mm thk, micro leveling and providing shim plates for erection of equipment / item at site shall be in the scope of bidder.
26.	All the fasteners which are in contact with slurry should be of High chrome/ Duplex material only. All other fastener shall be as per manufacturer's standard practice and proven experience. Bidder should ensure that the fasteners should not get corroded/damaged in case of spillage of slurry or due to any environmental condition. In case of corrosion or damaged the same needs to be replaced by the bidder without any cost implication to BHEL.
8.0	PACKING AND FORWARDING
1.	<p>Proper packing to be ensured.</p> <p>Indigenous Supply: Pump & sub system assembly shall be wrapped in polythene bags & packed in a strong rigid wooden crate. Rain water should not enter into the pump internals during storage in the outer yard of power plant.</p> <p>Imported Supply: All imported supply should be packed as per Sea worthy packing specification no. PE-TS-888-100-A001 (Annexure-H) .Liberal packing materials and struts shall be provided to arrest rolling and to protect from transit damages.</p>
2.	Equipment and process materials shall be packed and semi-knocked down, to the extent possible, to facilitate handling and storage and to protect bearings and other machine surfaces from oxidation. Each container, box, crate or bundle shall be reinforced with steel strapping in such a manner that breaking of one strap will not cause complete failure of packaging. The packing shall be of best standard to withstand rough handling and to provide suitable protection from tropical weather while in transit and while awaiting erection at the site.
3.	Equipment and materials in wooden cases or crates shall be properly cushioned to withstand the abuse of handling, transportation and storage. Packing shall include preservatives suitable to tropical conditions. All machine surfaces and bearings shall be coated with oxidation preventive compounds. All parts subject to damage when in contact with water shall be coated with suitable grease and wrapped in

 TECHNICAL SPECIFICATION OF SLURRY PUMPS	
ROS:9094:00	
S. No.	Description
	heavy asphalt or tar impregnated paper.
4.	Crates and packing material used for shipping will become the property of owner (CUSTOMER).
5.	Packaging or shipping units shall be designed within the limitations of the unloading facilities of the receiving ports and the ship will be used. It shall be the bidder's responsibility to investigate these limitations and to provide suitable packaging and shipping to permit transportation to site.
6.	Packing (tare) shall be part of the equipment cost and shall not be subject to return. The packing should ensure integrity and cohesiveness of each delivery batch of equipment during transportation. In case of equipment assemblies and unit's delivery in the packing of glass, plastics or paper the specification of packing with the material and weight characteristics are to be indicated.
7.	Each package should have the following inscriptions and signs stenciled with an indelible ink legibly and clearly: <ol style="list-style-type: none"> a. Destination b. Package Number c. Gross and Net Weight d. Dimensions e. Lifting places f. Handling marks and the following delivery marking
8.	Each package or shipping units shall be clearly marked or stenciled on at least two sides with project details as per enquiry. In addition, each package or shipping unit shall have the symbol painted in red on at least two sides of the package, covering one fourth of the area of the side.
9.	Each part of the equipment which is to be shipped as a separate piece or smaller parts packed within the same case shall be legibly marked to show the unit of which it is part, and match marked to show its relative position in the unit, to facilitate assembly in the field. Unit marks and match marks shall be made with steel stamps and with paint.
10.	Each case shall contain a packing list showing the detailed contents of the package. When any technical documents are supplied together with the shipment of materials no single package shall contain more than one set of such documents. Shipping papers shall clearly indicate in which packages the technical documents are contained.
11.	The case number shall be written in the form of a fraction, the numerator of which is the serial number of the case and the denominator the total number of case in which a complete unit of equipment is packed.
12.	Wherever necessary besides usual inscriptions the cases shall bear special indication such as "Top", "Do not turn over", "Care" , "Keep Dry" etc. as well as indication of the center of gravity (with red vertical lines) and places for attaching slings (with chain marks)
13.	Marking for Safe handling: To ensure safe handling, packing case shall be marked to show the following: <ol style="list-style-type: none"> a. Upright position b. Sling position and center of Gravity position c. Storage category d. Fragile components (to be marked properly with a clear warning for safe handling)

 TECHNICAL SPECIFICATION OF SLURRY PUMPS	
ROS:9094:00	
S. No.	Description
14.	Each crate or package is to contain a packing list in a waterproof envelope. All items are to be clearly marked for easy identification against the packing List. All cases, packages etc. are to be clearly marked on the outside to indicate the total weight where the weight is bearing and the correct position of the slings are to bear an identification mark relating them to the appropriate shipping documents. All stencil marks on the outside of cases are either to be made in waterproof material or protected by shellac or varnish to prevent obliteration in transit.
15.	The packing slip shall contain the following information: - Customer name, Name of the equipment, Purchase Order number with Date, Address of the delivery site, Name and Address of the Sender, Serial Number of pump & accessories, BHEL item Code, Gross Weight and Net weight of Supplied items.
16.	Prior to transport from manufacturer's work to destination, components of the unit shall be completely cleaned to remove any foreign particles. Flange faces and other machined surfaces shall be protected by an easily removable rust preventive coating followed by suitable wrapping.
17.	All necessary painting, corrosion protection & preservation measures shall be taken as specified in painting schedule. Supplier shall consider the coastal environment zone which is defined as "very severe" during final finishing/shipping.
18.	Successful bidder shall furnish the detail packing /shipment box details with information like packing box size, type of packing, weight of each consignment, sequence no. of dispatch, no. of consignment for each deliverable item against each billing break up units/ billable blocks. Without these details the BBU shall not be approved during detail engineering. Also, complete billing break-up with above mentioned details shall be submitted within 10days of LOI.
19.	All items/equipment shall be dispatched in properly packed condition (i.e. no item shall be dispatched in loose condition such that it becomes difficult to store/identify its location at site at a later stage).
20.	Cases which cannot be marked as above shall have metal tags with the necessary markings on them. The metal tags shall be securely attached to the packages with strong steel binding wire. Each piece, Skid, Case or package shipped separately shall be labelled or tagged properly. Note: Vendor to Provide photos of Packing boxes along with Packing box dimensions before dispatch.
9.0	SUPERVISION OF ERECTION, TESTING AND COMMISSIONING
1.	The erection of Slurry Pumps will be done by owner as per Erection Manual and check List. However, the bidder shall make visits for the supervision of erection, pre-commissioning & post- commissioning check-up, start-up, testing and trial runs of all the items covered under the scope of supply.
2.	Total number of visits shall be 6 and number of days per visit shall be 5 working days. Total number of working days= 6 x 5 = 30 days. Travel duration shall be additional.
3.	TA/DA, boarding and lodging shall be borne by the bidder and shall be inclusive in supply portion.
4.	Per day Charges for supervision shall be quoted by the bidder.
5.	Price comparison for evaluating the lowest bid will be considered all main supply, supervision of E&C charges and mandatory spares price all together.
10.0	EXCLUSIONS
	The following work associated with the slurry pump will be by BHEL: a. Civil foundations

 TECHNICAL SPECIFICATION OF SLURRY PUMPS	
ROS:9094:00	
S. No.	Description
	<ul style="list-style-type: none"> b. Walkways, platforms and ladders c. Element handling hoists
11.0	INSPECTION AND TESTING
A)	Minimum Testing requirements to be considered are as below: The typical quality plan is enclosed with this specification(ANNEXURE-G).
1.	Bidder shall submit the quality plan during the Post ordering stage subject to BHEL / end customer approval.
2.	For surfaces with rubber lining, degree of cleaning shall be visually checked before the application of the coating. There must be no area with oxidation, dirt or partially or generalized corrosion defects.
3.	Test certificates shall be issued for each lot of raw material used in the coating, corresponding to specific weight and traction resistance.
4.	For surfaces with rubber lining, adherence test shall be conducted on production samples. Adherence test shall be conducted on the actual surface through hammering. In order to verify the absence of air packets (or) surface without adherence.
5.	For surfaces with rubber lining, Coating thickness shall be checked at 100%. A High voltage porosity test will be conducted on 100 % of the coated surface.
B)	General Inspection requirements to be considered are as below:
1.	Bidder shall furnish written copies of shop production, fabrication and quality test procedures and drawings to be used for review by BHEL / CUSTOMER prior to manufacture. Inspection of above mentioned tests by BHEL/ CUSTOMER representative at bidder's works is envisaged.
2.	The Bidder shall furnish performance test procedure along with standard. The test procedure will be reviewed and approved by the BHEL/CUSTOMER.
3.	Slurry Pumps will be inspected at the Bidder's works before dispatch or where the test facilities are available.
4.	The Bidder shall conduct performance test for the remaining pumps and submit the reports.
5.	A dynamic balancing certificates evidencing that the rotating assembly has been balanced dynamically shall be sent to CUSTOMER/ BHEL within one (1) week of the successful completion of balancing.
6.	Acceptance tolerance of actual versus guaranteed performance for capacity, head, efficiency and power absorbed shall be as per applicable standard.
7.	Vibration levels shall be measured during shop running/performance tests.
8.	Contract shaft seals shall be used during shop tests, unless the seal design is unsuitable for the shop-test condition.
9.	Slurry pumps shall not be released for shipment, until shop tests data and performance tests curves have been approved by Owner.
10.	Bidder should furnish performance guarantee as per applicable standard guarantee for the design, manufacture, material and safe operation of the equipments.

 TECHNICAL SPECIFICATION OF SLURRY PUMPS	
ROS:9094:00	
S. No.	Description
11.	BHEL shall witness the test at Bidder's works and a notice of minimum three (3) weeks shall be given for attending the inspection.
12.	Bidder to arrange all calibrated gauges, Instruments during inspection.
13.	Mechanical running and the performance test shall be carried out at factory. Bidder to arrange Motor of same / higher rating for the shop test and inspection.
14.	The performance test may be carried out using water at shop and shall be converted to the design condition.
12.0	PAINTING – As per enclosed document Annexure-E
13.0	SPARES, TOOLS & TACKLES
13.1	START UP & COMMISSIONING SPARES
	Start-up & Commissioning Spares shall be part of the main supply of the Slurry pumps. Start-up & commissioning spares are those spares which may be required during the start- up and commissioning of the equipment/system. All spares required for successful operation till commissioning of pump shall come under this category. Bidder shall provide an adequate stock of such start up and commissioning spares to be brought by him to the site for the equipment erection and commissioning. The spares must be available at site before the equipments are energized.
13.2	MANDATORY SPARES
	The mandatory spares list is provided in the enclosed Annexure-D . The Mandatory spares price will be considered for bid evaluation. Mandatory spare parts items shall be handed over separately and shall not be mixed with the supply of the main equipment parts. Spares shall be sent in pre-decided lots in containers/secure boxes. All boxes/containers are to be distinctly marked in red color with boldly written "S" mark on each face of the containers. Spares shall not be dispatched before dispatch of main equipment's. Each item shall be labelled in English and be packed against damage and sealed to prevent deterioration from corrosion. All spares supplied under this contract shall be strictly inter-changeable with the parts for which they are intended for replacements. All the Initial spares shall be manufactures along with the main equipment components as a continuous operation as per same specification and quality plan. Supply of spares shall be subjected to the approval of BHEL
13.3	SPECIAL TOOLS & TACKLES:
	Any special tools & tackles required for the entire equipment to disassemble, assemble or maintain the units, they shall be included in the quotation and furnished as part of the initial supply of the machine. List of special tools & tackles shall be decided by bidder as per his proven practice. When special tools are provided, they shall be packaged in separate, boxes with lugs and marked as "Special Tools for (tag / item number)." Each tool shall be stamped or tagged to indicate its intended usage. Levers and eye bolts for the removal of parts to be serviced shall be submitted with special tools.
14.0	PERFORMANCE GUARANTEE
	All performance tests for Slurry pumps shall be carried out in accordance with any latest international codes/standards. Bidder to submit the PG test procedure for approval & Conductance of PG test shall be subjected to the final approval of end customer. 1) Bidder shall furnish Performance guarantee for the design, manufacture, material, safe and trouble-free operation of the Slurry pump and its accessories 2) Bidder shall guarantee and demonstrate the rated capacity of the pump at the rated head. 3) Noise level ≤ 85 dB (A) at 1m horizontal distance from equipment/enclosures is to be guaranteed.

 TECHNICAL SPECIFICATION OF SLURRY PUMPS	
ROS:9094:00	
S. No.	Description
	<p>4) Vibration levels measured on the non-rotating parts shall not exceed the zone limit "B" as defined in ISO 10816 at steady conditions and shall not exceed the zone limit "C" as defined in ISO 10816 at transient conditions.</p> <p>5) Acceptance tests to be carried out as per the procedure defined by the bidder which shall be submitted for BHEL/ CUSTOMER approval.</p> <p>6) In the event that the performance test is unsuccessful, bidder shall take necessary remedial action at his cost and the performance test shall be repeated.</p>
15.0	BID EVALUATION CRITERIA FOR POWER CONSUMPTION:
1.	<p>POWER GUARANTEE</p> <p>Bidder to specify the guaranteed power consumption at motor input terminal per Pump operating at the duty point in the offer.</p>
2.	<p>BID EVALUATION CRITERIA FOR POWER CONSUMPTION:</p> <p>Refer Annexure C</p>
16.0	LIQUIDATED DAMAGES FOR POWER CONSUMPTION
	Refer Annexure C
17.0	WARRANTY
1.	<p>Warrantee Shall be 24 months from the date of taking over by customer site / Operational acceptance or 36 months from the date of last supply of equipment whichever is earlier.</p> <p>Please note that overall warranty on Goods whether repaired / replaced in total shall not exceed 24 months from the date of such repair / replacement or 36 months from the date of last supply of equipment whichever is earlier. However, the warranty. Period shall not be extended beyond 24 months from the date when the Goods are first placed in commercial operation / Operational acceptance or 36 months from the date of last supply of main equipment whichever is earlier.</p> <p>Warrantee Shall be 24 months from the date of taking over by customer site / Operational acceptance or 36 months from the date of last supply of equipment whichever is earlier.</p> <p>Please note that overall warranty on Goods whether repaired / replaced in total shall not exceed 24 months from the date of such repair / replacement or 36 months from the date of last supply of equipment(including mandatory spares) whichever is earlier</p>
2.	In case of failure of the equipment to meet the guarantee, CUSTOMER/BHEL reserves the right to reject the equipment. However, CUSTOMER/BHEL reserves the right to use the equipment until new equipment supplied by bidder meets the guaranteed requirement.
18.0	FIRST FILL OF CONSUMABLES:
1.	Bidder's scope shall also include supply and filling of all chemicals, reagents, resins, lubricants, grease, filters and consumable items for operation up to commissioning including top up requirements. All lubricants proposed for the plant operation shall be suitable for all operating and environmental conditions that will be met on site consistent with good maintenance procedures as instructed in the maintenance manuals.

 TECHNICAL SPECIFICATION OF SLURRY PUMPS	
ROS:9094:00	
S. No.	Description
2.	Detailed specifications for the lubricating oil, grease, gases, servo fluids, control fluids, chemicals including items qualities and quantities required per month of the plant operation for the CUSTOMER/BHEL's approval herein shall be furnished within 2 months of placement of Order. On completion of erection complete list of bearings/equipment giving their location and identification marks shall be furnished to BHEL along with lubrication requirements. All types of chemicals, consumables, lubricants and grease shall be readily obtainable locally and the number of different types shall be kept to a minimum. For each type and grade of lubricant recommended, bidder shall list at least three equivalent lubricants manufactured by alternative companies.
19.0	TRAINING
	Successful bidder shall provide comprehensive training for CUSTOMER/BHEL Engineering, O&M, Erection & Commissioning staffs at site covering all aspects of the Slurry pumps - Operation & Maintenance, Troubleshooting etc. (for minimum 2 days).
20.0	CONFLICT
	Bidder's equipment shall be designed for and shall meet the service, performance and minimum level of quality requirements specified. Bidder shall be solely responsible for advising CUSTOMER in writing of any conflicts between the specifications and Bidder's design, including performance and levels of quality. Bidder agrees that its obligations, liabilities and warranties shall not be diminished or extinguished due to its meeting the requirements of the Specification.
21.0	DOCUMENTATION
A	DOCUMENTS TO BE SUBMITTED ALONG WITH THE OFFER
	The Bidder shall submit all documents, drawings, diagrams and all such information, which are necessary to fully understand the offer for techno – commercial evaluation. The documents mentioned as to be submitted along with the offer are required for proper evaluation purpose and vendors are requested to comply with above in all respect.
B	DOCUMENTS TO BE SUBMITTED AFTER AWARD OF CONTRACT
	The Successful bidder shall submit all documents, mentioned as to be submitted after award of contract , for review, approval. Drawings that are reviewed by the CUSTOMER/ BHEL will be returned to bidder with a transmittal letter with any comments and / or questions marked on the drawings or noted in the letter. All comments and questions must be resolved before a resubmission of drawings / documents. If the design has not developed enough to resolve some of the comments or questions, bidder shall place a "hold" on those items or areas of design. CUSTOMER/ BHEL reserves the right to return drawings unprocessed to bidder if there exists any evidence that bidder has not acknowledged all comments and questions. All necessary GA drawings, sections, sub-assembly drawings, specifications of main and sub components and necessary set of operation & maintenance manual as asked by CUSTOMER must be furnished by bidder in soft and hard copy forms. For all documents softcopy format shall be searchable pdf, however in addition all drawings, diagrams like P&IDS shall be supplied in ACAD or other editable format and all lists in Excel format. Further break up of technical documents will be discussed during finalization of the purchase contract. Unless agreed otherwise, ten (10) hard copies and five (05) sets of electronic copies of all documents are

	TECHNICAL SPECIFICATION OF SLURRY PUMPS
ROS:9094:00	
S. No.	Description
	to be submitted in the English language. Electronic Copies shall be submitted in primary original data format (e.g. DOC, XLS, DWG) as well as in a printable non-proprietary document format (e.g. PDF). Especially P&IDs shall be submitted as DWG files and PDF files. Bidder to ensure submission of hard copies as per CUSTOMER requirement for all engineering drg/doc and for all subsequent revisions along with a soft copy through email to concerned project team. However all the engineering related information shall be furnished in soft form to BHEL.

I. DOCUMENTS TO BE SUBMITTED ALONG WITH THE OFFER:

Sl. No.	Description	Require For Part	Purpose
1.	Annexure to qualification requirements : Attachment -3K	I	Qualification Requirement (QR)
2.	Reference plant details of similar or higher capacity Slurry Pumps supplied (ANNEXURE-I)	I	QR
3.	Seal & Sign of bidder on all pages of specification	I	Technical Evaluation of Bid(TEB)
4.	Deviation List (if any)	I	TEB
5.	Slurry Pump & Motor Sizing Calculation	I	TEB
6.	GA drawing all offered pumps with foundation details	I	TEB
7.	Filled Data Sheets of Slurry Pumps & All accessories	I	TEB
8.	Performance curves i. Flow v/s Head ii. Flow v/s NPSH iii. Flow v/s Efficiency iv. Flow v/s Power Consumption v. Torque v/s Speed curve for motor selection	I	TEB
9.	Required Electric power & other Utility List	I	TEB
10.	Make of all bought out items & sub vendor list	I	TEB
11.	Quality Plan	I	TEB
12.	List of Start-up & Commissioning Spares	I	TEB
13.	List of Special Tools	I	TEB
14.	Delivery Schedule	I	TEB
15.	Catalogue	I	TEB

II. DOCUMENTS TO BE SUBMITTED AFTER CONTRACT:

Sl. No.	Description	Handing over of Documents after Contract (in weeks)	Purpose
1.	Utility Consumption & Lubricating Oil List	2	Customer Approval
2.	Foundation Drawing, Foundation Bolts, static & dynamic details	2	Customer Approval

 TECHNICAL SPECIFICATION OF SLURRY PUMPS			
ROS:9094:00			
Sl. No.	Description	Handing over of Documents after Contract (in weeks)	Purpose
3.	GA drawing including cross sectional view of Slurry Pumps & Accessories with bill of material (in PDF & AutoCAD format)	2	Customer Approval
4.	GA drawings for Pumps in series arrangement with interconnecting piping & expansion joints drawings	2	Customer Approval
5.	P&ID drawing of Slurry Pumps & Lube Oil System in PDF & AUTOCAD format	3	Customer Approval
6.	GA drawings of mechanical seal and coupling for offered slurry pumps	3	Customer Approval
7.	Filled Data Sheets of Slurry Pumps & All accessories	3	Customer Approval
8.	Quality Plan with Inspection & Performance Test Procedure at site	3	Customer Approval
9.	Pump & Motor Sizing Calculation	4	Customer Approval
10.	Performance curves i. Flow v/s Total Pressure ii. Flow v/s Efficiency iii. Flow v/s Power consumption iv. Torque v/s Speed curve for motor selection	4	Customer Approval
11.	Motor Rating in KW	4	Customer Approval
12.	Sub vendors List	4	Customer Approval
13.	Manufacturing Schedule	4	Customer Approval
14.	Approximate weight of each skid	5	To arrange lifting
15.	List of Special Tools	8	E&C
16.	List of Start-up & Commissioning Spares	9	E&C
17.	Required Electric power	10	E&C
18.	Pre- Commissioning Check List	10	E&C
19.	Installation & assembly procedure	10	E&C
20.	Erection & Commissioning Schedule	10	E&C
21.	Recommended Repair Procedure	10	E&C
22.	Operation and Maintenance Manual (10 hardcopies and 5 electronic copies in English)	10	E&C
23.	Electrical Load List with Single Line Diagram	10	BHEL Review
24.	Control Logic of Slurry Pumps	10	BHEL Review
25.	Catalogue	10	BHEL Review
26.	Proforma Packing List	12	Dispatch

22.0 LIST OF TESTS FOR WHICH REPORTS HAVE TO BE SUBMITTED:



TECHNICAL SPECIFICATION OF SLURRY PUMPS

ROS:9094:00

The following type test reports shall be submitted for each type and rating of LT motor of above 50 KW only

1. Measurement of resistance of windings of stator and wound rotor.
2. No load test at rated voltage to determine input current power and speed
3. Open circuit voltage ratio of wound rotor motors (in case of Slip ring motors)
4. Full load test to determine efficiency power factor and slip.
5. Temperature rise test.
6. Momentary excess torque test.
7. High voltage test.
8. Test for vibration severity of motor.
9. Test for noise levels of motor:
 - Noise level for all the motors shall be limited to 85dB (A) except for BFP motor for which the maximum limit shall be 90 dB(A). Vibration shall be limited within the limits prescribed in IS/IEC 60034-14. Motors shall withstand vibrations produced by driven equipment. Motor bearing housings shall have flat surfaces, in both X and Y directions, suitable for mounting 80mmX80mm vibration pads (If applicable), if not Bidder to ensure & Vibration shall be within the limit prescribed in IS/IEC 60034-14 & HIS Standard. If Vibration limits exceeds Bidder to provide required support to rectify the issue with no cost implication to BHEL.
10. Test for degree of protection
11. Over speed test.
12. Type test reports for motors located in fuel oil area having flame proof enclosures as per IS 2148 / IEC 60079-1
 - All acceptance and routine tests as per the specification and relevant standards shall be carried out. Charges for these shall be deemed to be included in the equipment price.
 - The type test reports once approved for any projects shall be treated as reference. For subsequent projects of CUSTOMER, an endorsement sheet will be furnished by the manufacturer confirming similarity and "No design Change". Minor changes if any shall be highlighted on the endorsement sheet.

ANNEXURE - i : REFERENCE LIST FOR SLURRY PUMPS

Sl. No.	Project Name , Customer & Plant capacity	Coal fired Yes/No	Wet Limestone Based FGD Yes/No	Type of Slurry Pump	Model	Capacity	Head in meter of slurry column	Speed	Year of Com missioning	Qty
						m ³ /hr.	meter	rpm		

	TECHNICAL SPECIFICATION OF SLURRY PUMPS
ROS:9094:00	

ANNEXURE ii: LIST OF DEVIATIONS/EXCEPTIONS TO THE ENQUIRY DOCUMENT

Enquiry No : _____ ; Project : _____

SI No	Clause No	Page No	Description of Deviation

PROJECT:WBDCL Sagardighi 1x660MW				
SLURRY PUMP INPUTS		Annexure: R4W1 : A		
S.NO	Description	GYPSUM BLEED PUMP	AUXILIARY ABSORBENT TANK PUMP	ABSORBER AREA DRAIN SUMP PUMP
1	Pump sl.no	1	2	3
2	Pump KKS No.	10HTM00AP001/002	00HTT00AP001/002	10HTT00AP001
3	Pump location	Out door	Out door	Out door
4	Mounting orientation (H/V)(Horizontal/vertical)	H	H	V
5	Specific gravity of slurry	1.206	1.206	1.206
6	Viscosity at pump	0.01Pa.S	0.01 Pa.S	0.01Pa.S

954932/2022/BAP-9787_MKTING

7	Slurry concentration	30 wt%	30 wt%	30 wt%
8	Max solid particle size	150 mesh (140 micron)	150 mesh (140 micron)	150 mesh (140 micron)
9	Normal solid particle size,d50	325 mesh (43 micron)	325 mesh (43 micron)	325 mesh (43 micron)
10	Hardness of particle	5-7(Mohs scale)	5-7(Mohs scale)	5-7(Mohs scale)
11	Chloride concentration	25000 ppm (max)	25000 ppm (max)	25000 ppm (max)
12	Slurry to be handled	Gypsum slurry	Gypsum slurry	Gypsum slurry
13	SiO2 concentration	10 g/l	10 g/l	10 g/l
14	ph	4-8	4-8	4-8
15	Minimum & maximum liquid level in the tank(in m)	1.5-6.5	1-12.3	1.4-3.5(Sump height 4.3m)
16	Operating temperature range	10-70 deg C	10-70 deg C	10-70 deg C
17	Capacity of pump (in m3/hr)	140	140	125
18	Head of the pump (in meter of slurry column)	40	20	20

954932/2022/BAP-9787_MKTING

19	Number of pump	2 nos.	2 nos.	1 no.
20	Working and standby	(1W + 1 S)	(1W + 1 S)	1W
21	Discharge orientation	Vertical up	Vertical up	Vertical up
22	Duty condition(continuous/intermittent)	Continuous	Intermittent	Intermittent
23	Power loading for bid evaluation	Applicable	NA	NA
24	Pump Efficiency	Minimum 60 %	Minimum 60 %	Minimum 45 %
25	Flange standard	B16.5 class 150	B16.5 class 150	B16.5 class 150
26	Mechanical seal required	with Quenching Plan API 62	with Quenching Plan API 62	NA
27	Connecting piping	-	-	CD4mCu for elbow and SS316L for pipe
28	Power consumption (Celing Value) per Pump in kW (At Motor Terminal Input)	35	-	-
29	Pump model offered to be mentioned by vendor			
30	Inlet and outlet dia of pump- vendor to furnish			

31	Impeller diameter - vendor to furnish			
32	Impeller RPM - vendor to furnish			
33	Tip speed of impeller (a) for rubber lined pumps should not exceed 25m/sec, (b) for other pumps should not exceed 30m/sec- vendor to furnish			
34	GD ² at Drive end Shaft to be Provided.			
35	Bearing cooling air /oil/water - if any required vendor to specify			
36	Pump efficiency Vendor to specify (subject to BHEL's approval)			
37	The operating range of the pump shall be 40% to 120% of the duty point - vendor to confirm			
38	The maximum efficiency of pump shall preferably be within $\pm 10\%$ of the duty point flow			
39	Shut-off head to be furnished.			
40	Common base plate to be provided by vendor A29/A36 /A283/IS2062 or equivalent international standard			

954932/2022/BAP-9787_MKTING

41	Vibration pad required (between base plate and pump & motor) vendor to provide & confirm			
42	Any other slurry wetted parts shall be made of Duplex 2205			
43	Name plate shall be in SS 304 - vendor to confirm			
44	Rotation arrow to be cast in the body or arrow plate with SS304 to be fixed on the pump - vendor to confirm			
45	Direct Drive flexible coupling with high tensile bolts is to be provided by vendor. Coupling make and model Number Coupling drawing with BOM to be provided after purchase order. In case of Belt drive, vendor to provide Pulley drawing & Belt size. Vendor to confirm			
46	Coupling guards with mounting fasteners with spring washerto be provided . Incase of Belt Drive Belt guard to be provided with all its fittings. Vendor to Confirm.			
47	Mechanical drawing with complete BOM to be provided after purchase order.			
48	Temporary conical strainer to be provided - vendor to confirm			
49	Mechanical seal with applicable API Plan : vendor to confirm			

954932/2022/BAP-9787_MKTING

50	Quenching water Quantity , quality & pressure shall be informed by the vendor			
51	pump shaft power (BKW) for each pump to be provided			
52	Motor efficiency class (minimum IE3)			
53	Guaranteed power consumption in KW (Backup calculation for power consumption to be provided)			
54	Motor rating to be furnished for all motor along with backup calculation			
55	First fill oil /grease other consumable to be sent along with pump and grade to be mentioned of the same- vendor to confirm			

ANNEXURE: R4W1: B (PROVENNESS CRITERIA)

Bidder should have previous experience of manufacturing and supplying of Slurry Pumps for the FGD System/Ash handling system or similar application with a minimum pump rating as stipulated below such that the pump should have been in successful operation in at least two (2) separate plants for a period not less than two year from the Techno-Commercial BID opening date of this tender.

Offers of bidders who do not meet qualification requirement will not be considered.

Type and Rating for Qualification (Bidder shall submit filled in Annexure-i & necessary supporting documents).

Name of Equipment	Type of Equipment	Application	Equipment Rating
Slurry Pumps	Centrifugal type	FGD or Ash handling or similar application	Minimum Head : 40 meter of slurry column Minimum Flow: 140 m ³ /hr.

Bidder shall offer and supply only the type of the above equipment(s) for which the Bidder itself is qualified.

Bidder to provide supporting documents meeting QR such as GA drawing/Approved Data Sheet/ Purchase Order Copy/ Inspection Clearance Report/ End-user performance Certificate to meet the above qualification requirement.

SIGNATURE OF BIDDER

NAME

DESIGNATION

POWER LOADING & LIQUIDATED DAMAGES FOR NORTH CHENNAI (1 X 800 MW)**ANNEXURE: R4W1:C****BID EVALUATION CRITERIA FOR POWER CONSUMPTION**

Power loading shall be applicable for slurry pumps designated as “continuous duty condition” in enclosed pump datasheet.

In case, Guaranteed Shaft power offered by the bidder exceeds the base value specified, his bid price will be loaded for excess power consumption as per the formula given below.

Adjustment factor for excess power consumption in INR = (GPC-BV) X PL X No's of Working pumps

GPC- Guaranteed Power Consumption quoted by bidder in KW

BV- Base Value. (Auxiliary Power Consumption at motor Input, refer **Annexure-A Sino-26**)

PL- Power Loading

LIQUIDATED DAMAGES FOR POWER CONSUMPTION

1. If actual Power Consumption at motor input terminal during prove out (or) PG Test operating at the duty point exceeds the value guaranteed by the bidder, liquidated damages for shortfall in performance shall be deducted from contract price as per the formula given below

Liquidated damage deductible in INR = (APC-GPC) X P X No's of Working pumps

Where

- GPC- Guaranteed Power Consumption quoted by bidder in KW
- APC- Actual Power Consumption in KW
- P- Penalty

Note:

1. LD will be levied after conducting performance test as above. Contractor's aggregate liability to pay penalty for failure to achieve the performance guarantee shall not exceed 10% of the Contract price plus applicable GST. All these penalties for shortfall in performance shall be deducted from the contract price.

2. For conducting PG test at project site for demonstrating the guaranteed parameters of pump, vendor has to make own arrangement for TA/DA and hotel charges, which is to be considered while submitting the offer.

SL NO	DESCRIPTION PROJECTS	POWER LOADING (PL) for Clause 15 of ROS:9093 Rev:01	LIQUIDATED DAMAGES (LD) (P) for Clause 16.0 of ROS:9093 Rev:0
1	WBPDCL SAGARDIGHI 1X660 MW	Rs. 462,000/- for every KW increase from the values mentioned in the tender.	Rs. 462,000/- for every KW excess auxiliary power consumption over guaranteed value on the basis of Figures declared by the bidder in Attachment-X.

Note: In case, guaranteed power input at motor terminal offered by the bidder exceeds the base value specified in the data sheet, his bid price will be loaded for excess power consumption.

For lower values no loading will be considered.

Note: Acceptable shortfall Limit with LD (+1%) of the guaranteed auxiliary power consumption.

SUPERVISOR & MANDATORY SPARES FOR SLURRY PUMPS FOR WBPDCS SAGARDIGHI (1x660MW)														Annexure : R4W1:D								
SLURRY PUMPS FOR WBPDCS SAGARDIGHI (1x660MW) : (R4W1)							Mandatory Spares															
							Note : Bidder to clearly mention the model number for each of the spares. Bidder to optimize the number of mandatory spares based on the repetition and applicability & Type. Horizontal & Vertical pumps are to be considered of different type & should not be considered as repetitive & spares should be supplied for both type. Bidder to clearly mention C: Considered , R: Repetitive or NA : Not Applicable in the respective columns for each mandatory spare.															
Main Supply							Supervision		(1) Impeller Assembly - 1 nos. of each type		2) Casing Liners (if replaceable liners applicable) - 1 nos. of each type		(3) Seals -1 no. of each type		(4) Bearings -1 No. of each type		(5) Motor -1 No. for each type		(6) Motor-Pump Coupling - 1 No. of each type			
Sl. No.	Description	Head of each pump (in meter of slurry column)	Capacity of each pump (in m3/hr)	Total Number of pump	Model Selected (to be filled by vendor)	Bidder to furnish : QUOTED/NOT QUOTED	Total Visits	Total Supervision Charges : QUOTED/NOT QUOTED	Model	C :Considered R : Repetitive NA : Not Applicable	Model	C :Considered R : Repetitive NA : Not Applicable	Model	C :Considered R : Repetitive NA : Not Applicable	Model	C :Considered R : Repetitive NA : Not Applicable	Model	C :Considered R : Repetitive NA : Not Applicable	Model	C :Considered R : Repetitive NA : Not Applicable		
1	GYPSUM BLEED PUMP	40	140	(1W+1S)			Bidder to consider 3 visits each of 5 Working Days.															
2	AUXILIARY ABSORBENT TANK PUMP	20	140	(1W+1S)																		
3	ABSORBER AREA DRAIN SUMP PUMP	20	125	1W						(1) Complete Impeller assembly - 1 no. of each type.		(2) Casing Liners - 1 set* of each type		(3) Bearings -1 set (set shall comprise of complete replacement of one pump-motor assembly)		(4) Motor - 1 no.						
									Model	C :Considered R : Repetitive NA : Not Applicable	Model	C :Considered R : Repetitive NA : Not Applicable	Model	C :Considered R : Repetitive NA : Not Applicable	Model	C :Considered R : Repetitive NA : Not Applicable						

Note : Frame Plate Liner, Cover Plate Liner, Volute Liner , Back Plate Liner & throat bush (As Applicable) to be considered as replaceable Casing Liners.
 Any change in size, material, design etc, which obviates one to one replacement of the part shall be considered a different type.
 * Unless otherwise stated, a set shall mean complete replacement for one equipment.

 Ranipet	Painting schedule for APH, ESP, FAN, FGD, Water Treatment and Gates & Damper for 1X660 MW Sagardighi TPP, Extension, Unit-5 (BHEL WO NO: R681, R4W1 & R4W2) Cust. Drg. No.:RP-MQ-445-ESP-E049 Rev 04	Doc No: PS:SAGA:R681 Date: 21/12/2020 Page 7 of 13 Rev 04
--	---	---

SI No	Description / PGMA	Surface preparation	Primer/ DFT in μm	Intermediate DFT	Finish DFT	Total DFT
20	Absorber System Base, Structures, Casing bottom Outside surfaces, Casing Top Outside surfaces (FW 219, FW 221, FW222,FW300, FW301,FW302, FW303, FW322,FW285,FW228, FW229), Emergency quench water tank Outside surfaces (FW 226), STRUCTURES FOR RC PUMP (FW236),MANHOLE DOOR FOR ABSORBER (FW209), ABSORBER SYSTEM INTERNALS-STRUCTURAL(FW213), EMERGENT QUENCH SYSTEM (FW227), OXIDATION AIR DIST SYSTEM (FW244), ABSORBER SHEAR PLATE(FW231),MIST ELIMINATOR& ACCESSORIES (FW215),ABS BAFFLE GRATING SUPPORT (FW216), ABS ME SUPPORT(FW217), ABS SPRAY PIPE SUPPORT(FW218), DUCTSUPPORT FW232,FW234),Duct structure between duct (FW 260), Duct structure between scrubber (FW 262), Supporting structure for Bypass duct (FW286), Structures for Elevator (FW 292),ELEVATOR STRUCTURES(FW380, FW381,FW382) Galleries and Railings Structural items (FW 612,FW613), Monorail for Hoist & Cranes (FW 710), Structure for Pipe racks (FW 761), Trestle for Pipe racks (FW 762); Agitator support (FW 721);PIPE SUPPORT(FW793); ABS RC PUMP NOZZLE (FW201), ABS NOZZLE (FW202, FW203); ELEVATOR (FW293); PIPE ACCESSORIES AND VALVES(FW 751, FW752, FW752,FW753,FW754,FW755, FW758);ELEVATOR M/C ROOM(FW385); SLURRY PUMP (FW701); WATER PUMP (FW702);RC PUMP INLET OUTLET VALVE (FW815); HANDLING EQUIPMENT FOR FGD (FW715);_AIR RECEIVERS (FW798),	Blast cleaning to near white metal Sa 2½ (SSPC SP10)	Epoxy resin based Zinc phosphate primer to IS 13238; 100 μm	Epoxy resin based Titanium Dioxide pigmented intermediate coat; 100 μm	Epoxy based polyamide cured finish paint to IS 14209 (Latest); 75 μm At Site: Aliphatic acrylic polyurethane paint to IS 13213; 25μm Smoke grey Shade 692 of IS 5	300 μm (min)



PRODUCT STANDARD
ELECTRICAL, CONTROLS & INSTRUMENTATION
BAP / BHEL / RANIPET – 632 406

TECI: LT MOTOR: REV 05
PAGE 1 OF 10
EFFECTIVE DATE : 28.07.2021

DOCUMENT TITLE : TECHNICAL SPECIFICATION FOR BOUGHT OUT ITEMS

ITEM : LT MOTOR

PROJECT : BHEL STANDARD

	NAME	DESIGNATION	SIGNATURE	DATE
PREPARED BY	ALAN S G	ENGINEER		28/7/2021
REVIEWED BY	CHANDRASEKAR A P	DM		28-07-2021
APPROVED BY	JEYAMURUGANAND M	AGM		28/07/2021

ISSUED BY EDC – ECI

RECORD OF REVISIONS:

REVISION NUMBER 00	INITIAL RELEASE - Dt. 19.03.2013
REVISION NUMBER 01	
REVISION NUMBER 02	Cl. No: 5- Packing and Drawing included
REVISION NUMBER 03	Cl. No: 2.20, 2.21, 2.38, 2.39, 2.43 added
REVISION NUMBER 04	Cl.No: 2.3, 4(b) - ECI:DATASHEET:LTMOTOR:00 added
REVISION NUMBER 05	Cl.No: 2.36, 2.40, 4(b), 5(a) Updated

PRODUCT STANDARD
ELECTRICAL, CONTROLS & INSTRUMENTATION
BAP / BHEL / RANIPET – 632 406

TECI: LT MOTOR: REV 05
PAGE 2 OF 10
EFFECTIVE DATE : 28.07.2021

	<u>SPECIFICATION</u>	<u>VENDOR COMPLIANCE/ REMARKS</u>
1	<u>SITE CONDITIONS</u>	
1.1	Altitude above mean sea level	>1000 m.
1.2	Ambient temperature condition	6 to 50°C.
1.3	Relative humidity	100%
1.4	Atmosphere	Tropical, Dusty, salty, corrosive & highly polluted as in a coal based Thermal power plant.
2	<u>GENERAL</u>	
2.1	Reference standards	IS 15999, IS 12615, IS/IEC-60034, IS 1231, IS 6362, IS 2253, IS 12065, IS 12075
2.2	Design ambient	50 Deg.C
2.3	Application/ Type(Normal/ Energy efficient)	As per the document LT MOTOR:PROJECT SPECIFIC DETAILS
2.4	Duty cycle	Continuous S1
2.5	Rated voltage, frequency & Phases	415 V AC $\pm 10\%$; 50 Hz (+5% to -5%); 3 phase
2.6	Combined variation of Voltage and frequency	10% absolute sum
2.7	Motors efficiency class	As per the document LT MOTOR:PROJECT SPECIFIC DETAILS
2.8	Minimum starting voltage	80% of the rated voltage
2.9	Minimum voltage under which motor will run satisfactorily	75% of the rated voltage for 5 minutes
2.10.	Capacity to restart (at specified voltage)	i. Two successive starts from cold condition ii. Two HOT restarts starts from Hot condition iii. Three equally spread start per hour
2.11	High speed bus transfer withstand capability	Suitable to withstand 150 % of rated voltage
2.12	Type of balancing for rotor	Dynamic balancing
2.13	Direction of rotation	Suitable for both direction
2.14	Direction of cooling air	Non-drive end to driving end
2.15	Class of insulation	Class F with temperature rise limited to Class B.
2.16	Winding treatment	The insulation shall be given tropical and fungicidal treatment for successful operation of the motor in hot, humid & tropical climate.
2.17	Allowed winding temperature rise at continuous full load	60°C by thermometer method & 70°C by resistance method
2.18	Accelerating Torque at minimum permissible Starting voltage	10% of full Load Torque

PRODUCT STANDARD
ELECTRICAL, CONTROLS & INSTRUMENTATION
BAP / BHEL / RANIPET – 632 406

TECI: LT MOTOR: REV 05
PAGE 3 OF 10
EFFECTIVE DATE : 28.07.2021

2.19	Pullout Torque at rated voltage	205% of full load torque	
2.20.	Ratio of Locked rotor KVA to KW for	As per the document LT MOTOR:PROJECT SPECIFIC DETAILS	
2.21	Starting current	As per the document LT MOTOR:PROJECT SPECIFIC DETAILS	
2.22	Starting time & locked rotor withstand time	The locked rotor withstand time (LRWT) at 110% rated voltage (RV) under HOT condition shall be at least 2.5 sec more than the starting time at 80% of rated voltage for motors with acceleration time upto 20 sec at RV and 5 sec where the accelerating time is more than 20 sec at RV.	
2.23	Momentary overload withstand capability	60% of full load torque for 15 second without any damage.	
2.24	Over speed withstand	120% of rated speed for 2 minutes without any mechanical damage.	
2.25	Hot thermal withstand curve	margin of at least 10% over the full load current	
2.26	Cooling	Totally enclosed fan cooled- IC 411(TEFC)	
2.27	Vibration	The peak amplitude of vibration shall be as per IS 12075	
2.28	Noise level	Within the limits specified by IS 12065 / <85 dB at 1 meter distance from motor.	
2.29	Type of enclosure	TEFC, IP 55 as per IS/IEC 60034-5	
2.30.	Type of mounting	Horizontal foot mounted.	
2.31	Bearings	Ball or roller type / bearings effectively sealed against ingress of dust. The bearing shall be so constructed that the loss of lubricating grease is kept to minimum. Sealed bearings are also acceptable	
2.32	Lubricant Type	Grease	
2.33	Bearing life	minimum life of 40000 Working hours	
2.34	Shaft extension	Key slotted bare shaft extension with key at the driving end.	
2.35	Terminal box Type	Weather proof IP 55 as per IS/IEC 60034-5; Capable of being turned through 360° in steps of 90°.	
2.36	Cable gland and lugs	Double compression type nickel plated brass cable glands and annealed tinned copper crimping lugs to suit the cable size i) Size of power cables will be intimated after PO. ii) For space heater cable glands and lugs suitable for 2CX2.5 to be provided	

PRODUCT STANDARD
ELECTRICAL, CONTROLS & INSTRUMENTATION
BAP / BHEL / RANIPET – 632 406

TECI: LT MOTOR: REV 05
PAGE 4 OF 10
EFFECTIVE DATE : 28.07.2021

2.37	Type of terminals	Stud / screw type with plain washers, spring washers / checknuts & lugs	
2.38	Min.Spacing between Gland plate and Center stud(in mm)	As per the document LT MOTOR:PROJECT SPECIFIC DETAILS	
2.39	Phase to Phase/Phase to Earth air clearance(in mm) in Terminal Box	As per the document LT MOTOR:PROJECT SPECIFIC DETAILS	
2.40.	Fault level	40KA for 0.25Sec	
2.41	Painting	As per the document LT MOTOR:PROJECT SPECIFIC DETAILS	
2.42	Space heaters:		
2.42.a	i) Motors above 30 kW	Separate space heater suitable for 240V, Single Phase, AC,50 Hz	
2.42.b	ii) Motors below 30 kW	Winding shall be suitable for heating at 24 V, Single phase, AC,50 Hz	
2.43	Terminals for space heater	As per the document LT MOTOR:PROJECT SPECIFIC DETAILS	
2.44	RTD for winding	Two numbers of Thermistors / RTD for each phase as below are to be provided A. Motors above 37 Kw shall have thermistors Or RTD if specifically called for in enquiry. B. Motor rated 160kW and above shall have RTDs	
2.45	Bearing RTD	For motors 132 Kw and above	
2.46	Terminals for RTD/ Thermistor	Thermistors/ RTDs shall be terminated in an auxiliary terminal box. Details shall be furnished in TB diagram.	
2.47	Earthing	Two no of earthing provisions on terminal box and on motor body(on opposite sides)	
2.48	Name plate	As per IS/IEC 60034-8 and Additional data on name plate : a. Bearing DE/ NDE details. b. Year of manufacture	
2.49	Lifting Device	Eye bolt or lugs to facilitate safe lifting	
3	<u>INSPECTION & TESTING</u>	As per applicable quality plan	

PRODUCT STANDARD
ELECTRICAL, CONTROLS & INSTRUMENTATION
BAP / BHEL / RANIPET – 632 406

TECI: LT MOTOR: REV 05
PAGE 5 OF 10
EFFECTIVE DATE : 28.07.2021

4 **DOCUMENTS**

a) Along with offer:	One set of technical data sheet as per the enclosed format and Motor general arrangement drawing giving foundation details, shaft details.	
b) After placement of Purchase order (within 15 days)	<p>Three sets of the following for approval:</p> <ol style="list-style-type: none"> 1. Technical Data sheet as per the enclosed format ECI:DATASHEET:LTMOTOR:00 2. Motor general arrangement drawing giving foundation details, shaft details and weight 3. Motor Terminal box arrangement drawing 4. Motor characteristic curves : Torque vs Speed with load curve superimposed Speed vs Current Time vs Current Thermal with stand curve Load vs Efficiency Load vs Slip Load vs Power factor Speed vs Time Load vs Current 5. Suggested steel crate packing drawing (Drawing No:- 3-00-114-39893) or vendor standard packing drawing subject to approval. <p>The following shall be submitted:</p> <ol style="list-style-type: none"> 1. Guarantee certificate. 2. O & M manuals. 3. Acceleration time and LRWT calculation shall be submitted for review. 	

5 **PACKING**

	<ol style="list-style-type: none"> a) As per suggested Drawing No:- 3-00-114-39893 b) The packing shall meet the Transport, Environment & Storage hazards. c) As per Packing Procedure QA:CI: STD:PR:03 or as per Manufacturer's Standard Practice subject to approval. 	
--	--	--

PRODUCT STANDARD
 ELECTRICAL, CONTROLS & INSTRUMENTATION
 BAP / BHEL / RANIPET – 632 406

TECI: LT MOTOR: REV 05
 PAGE 6 OF 10
 EFFECTIVE DATE : 28.07.2021

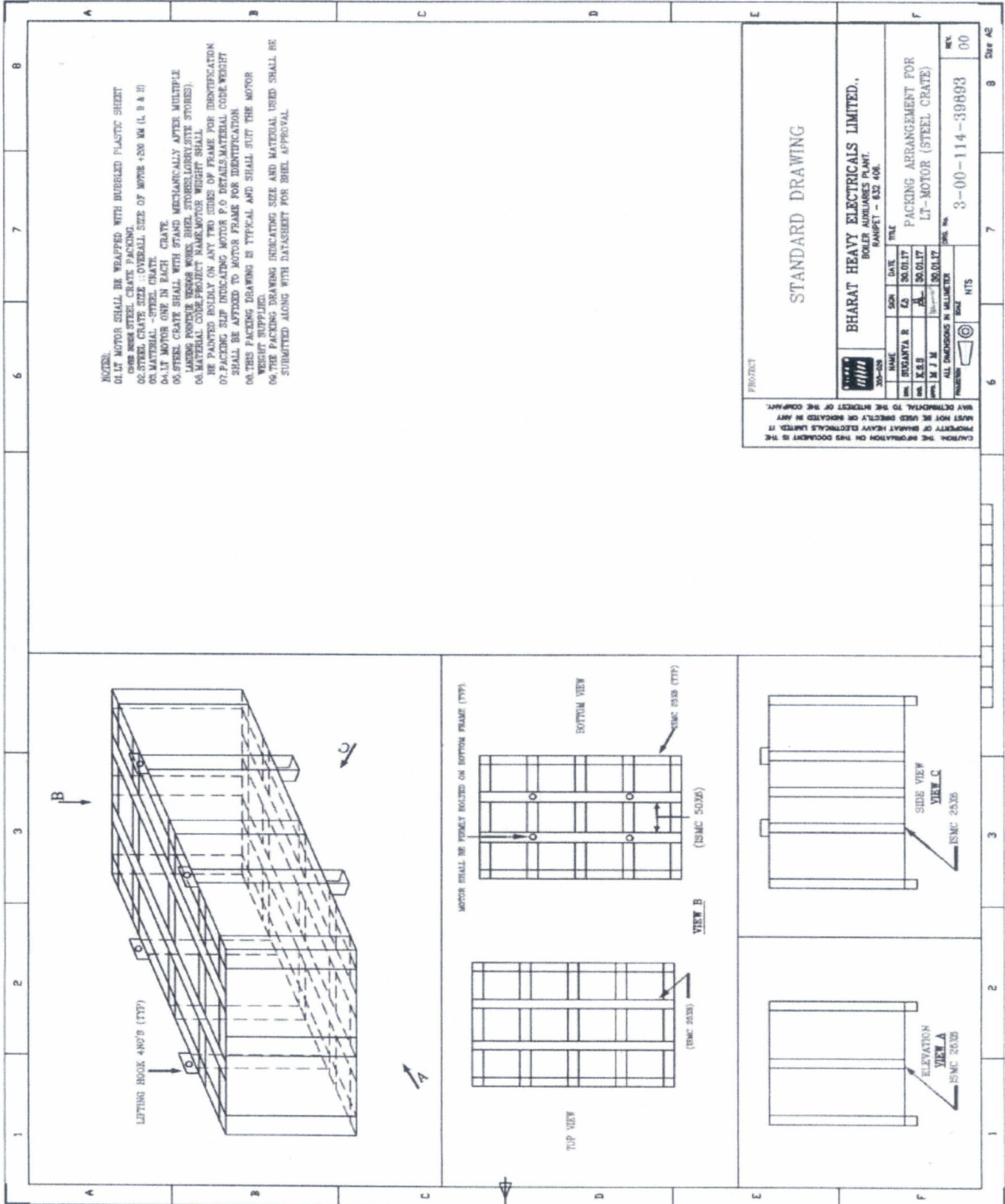

PRODUCT STANDARD
ELECTRICAL, CONTROLS & INSTRUMENTATION
BAP / BHEL / RANIPET – 632 406

TECI: LT MOTOR: REV 05
PAGE 7 OF 10
EFFECTIVE DATE : 28.07.2021

ECI: DATASHEET: LTMOTOR: 00

TECHNICAL DATA SHEET OF LT MOTOR

P.O No:

DATA SHEET - Customer No: Project:

CL.NO	CHARACTERISTICS	VENDOR DATA(To be filled by Vendor)
1.0	Application	
1.1	Fan / Load Curve referred	
2.0	Manufacturer	
3.0	Type & frame size	Normal/ Energy efficient Frame size:
3.1	Degree of Protection	IP55
4.0	Rated output in kW	
4.1	Rated speed	
5.0	Rated voltage , frequency & phases	415 V \pm 10% AC; 50 Hz \pm 5%; (Check voltaqe as per Enquiry) 10% absolute sum; 3 phase
6.0	Full load current	Amps
7.0	Energy efficient	As per IS 12615
8.0	Efficiency & power factor at Full load	Eff- Pf-
9.0	Efficiency & power factor at 75 % load	Eff- Pf-
10.0	Efficiency & power factor at 50 % load	Eff- Pf-
11.0	Duty Cycle	S1 - Continuous
12.0	Rated torque	
13.0	Starting current	As per IS standards
14.0	No load current (with mechanism coupled)	(at Rated.V and Frequency)
15.0	Starting torque in % of full load torque	
16.0	Pull up torque in % of full load torque	
17.0	Pull out torque in % of full load torque	

PRODUCT STANDARD
ELECTRICAL, CONTROLS & INSTRUMENTATION
BAP / BHEL / RANIPET – 632 406

TECI: LT MOTOR: REV 05
PAGE 8 OF 10
EFFECTIVE DATE : 28.07.2021

18.0	No load starting time (without mechanism coupled)	
19.0	Locked rotor withstand time at rated voltage	a.Hot b.Cold
20.0	Locked rotor withstand time at minimum starting voltage	a.Hot b.Cold
21.0	Locked rotor withstand time at 110% rated voltage	a.Hot b.Cold
22.0	Starting time at minimum starting voltage with mechanism coupled	
23.0	Starting time at rated voltage with mechanism coupled	
24.0	Maximum permissible starting time	
25.0	Stator thermal time constant	Minutes
26.0	Type & No of terminals brought out	
27.0	Stator winding connection	Delta / Star
28.0	Class of insulation & temperature rise	Class F; 60 ⁰ C by thermometer method / 70 ⁰ C by resistance method.
29.0	Minimum permissible starting voltage	Volts
30.0	Resistance per phase at 20Deg C (Indicative)	Ohms
31.0	No of successive starts in Hot condition	
32.0	Quantity and power consumption of space heater	Quantity: Watts:
33.0	Direction of rotation	Bi-Directional.
34.0	Bearing make & type	Make: Drive End: Non Drive End:
35.0	Lubricant quantity grade & recommended interval of lubrication	

PRODUCT STANDARD
ELECTRICAL, CONTROLS & INSTRUMENTATION
BAP / BHEL / RANIPET – 632 406

TECI: LT MOTOR: REV 05
PAGE 9 OF 10
EFFECTIVE DATE : 28.07.2021

36.0	Type of mounting & shaft orientation	Foot mounting; Horizontal.
	<u>Terminal Box</u>	
37.0	Location & angle of rotation	
38.0	Gland size for stator winding	
39.0	Gland size for space heater	Suitable for 2CX2.5 sq.mm (armoured), if applicable.
40.0	Cable entry	
41.0	GD ² of motor (kg-m ²)	
42.0	Total weight of motor (kg).	
43.0	Weight of stator (kg)	
44.0	Weight of rotor (kg)	
45.0	Anticipated bearing life in Hours	
46.0	Method of connection to driven equipment	
47.0	Limiting rotor temperature for determining safe stall time	
48.0	RTD for winding/ Bearing	Applicable: YES <input type="checkbox"/> NO <input type="checkbox"/>
49.0	Grade of balance of motor	
50.0	Standard continuous rating at 40 Deg C ambient.	
51.0	Derated rating of motor at 50 Deg C.	
52.0	a. Locked Rotor KVA	
	b. Ratio of Locked rotor KVA / Rated KW	
53.0	a. Motor Dynamic Load	Upward/ Downward—
	b. Motor Static load	Upward / Downward—
54.0	PAINT SHADE	

Vendor's signature and seal

Rev No :

Date :

PRODUCT STANDARD
ELECTRICAL, CONTROLS & INSTRUMENTATION
BAP / BHEL / RANIPET – 632 406

TECI: LT MOTOR: REV 05
PAGE 10 OF 10
EFFECTIVE DATE : 28.07.2021

The following curves are to be enclosed during datasheet approval.

1. GA drawing , Terminal box arrangement
2. Torque Vs Speed with load curve superimposed.
3. Speed Vs Current
4. Time Vs Current
5. Thermal with stand curve
6. Load Vs Efficiency
7. Load Vs Slip
8. Load Vs Power factor
9. Speed Vs Time
10. Load Vs Current.

The following information shall be specifically provided for motors suitable for VFD drive (if called for in eqny during datasheet approval in addition to datasheet.

1. Stator Resistance
2. Stator leakage reactance
3. Magnetising reactance
4. Rotor resistance referred to stator
5. Rotor reactance referred to stator

Vendor's signature and seal.

Date

ANNEXURE-R4W1: G
SCHEDULE OF GUARANTEES

SL NO	DESCRIPTION	GYPSUM BLEED PUMP	AUXILIARY ABSORBENT TANK PUMP	ABSORBER AREA DRAIN SUMP PUMP
1	Rated Capacity of the Pump. (m ³ /hr)			
2	Total Head at design capacity. (m)			
3	Guaranteed power consumption at Motor input Terminal at rated Head & capacity. (kw)			
4	Noise level at a distance of 1.0 meter from the equipment at site and 1.5m above operating floor. dB(A)			
5	Maximum vibration (peak to peak amplitude at site). (Microns)			
6	Equipment Availability. (%)			
7	Pump Efficiency (%)			
8	Life of the Pump wear parts including Casing liners bearing etc. (Hours) as per the following: a) Casing Liner Life : 14000 hrs for Rubber lined, 24000 hrs for hi-chrome. b) Impeller Liner Life : 14000 hrs c) Bearing Life : 20000 hrs of continuous operation d) Mechanical seal Life: 14000 hrs			

Note: Bidder to provide the details for the applicable pumps.

Signature of the Bidder.....

Name.....

VOLUME IIB

**TECHNICAL SPECIFICATION
FOR
SEAWORTHY PACKING FOR EXPORT JOBS**

SPECIFICATION NO. PE-TS-888-100-A001



**BHARAT HEAVY ELECTRICALS LIMITED
POWER SECTOR
PROJECT ENGINEERING MANAGEMENT
NEW DELHI, INDIA**

	TITLE	SPECIFICATION NO. PE-TS-888-100-A001	
	TECHNICAL SPECIFICATION FOR SEAWORTHY PACKING FOR EXPORT JOBS	VOLUME II B	
		SECTION D	
		REV. NO. 0	DATE 10/08/2010
		SHEET 1 OF 52	

1.0 Purpose

The purpose of this specification is to describe minimum packing requirements for the different items/equipment for all export Project and also to define marking and shipping requirements during transportation by ship, road and air for all export jobs.

2.0 SCOPE

For export jobs, sea worthy packing capable of performing all necessary functions like prevention of damage to the contents, sufficient to support frequent handling and lengthy period of outdoor storage in adverse weather conditions are required. Workmanship and materials used shall be of high standard meeting the technical requirements and in accordance with best commercial export packing practices. Vendor shall be responsible for sea worthy export packing, however it shall meet the minimum requirements specified herein. Equivalent or better packing methods may be deployed subject to approval of the BHEL/Purchaser. Vendor shall submit the packing procedure for its equivalent for purchaser's approval during detailed engineering.

The scope this specification is to define VENDOR's responsibilities in terms of:

- Preservation of the GOODS/items/equipments before packing.
- Packing of the GOODS for road, rail, sea and/or air transportation to desired destination i.e. project site
- Making cases/crates
- Chemical Treatment/Fumigation before packing to prevent fungus, damage due to termite, borer, rats, etc.
- Marking of cases/crates.
- Other Services required.

3.0 Application

This specification is applicable to all the goods to be transported to project site and requires to be in transit for longer duration. *However, for "Misc cable erection items", "Fire sealing system" & "Exothermic welding material", the packing requirements shall be as per the procurement specification.*

4.0 Definitions

- "BHEL" : Main EPC vendor
- "OWNER" : Customer for a particular export project.
- "VENDOR" : Company(ies)/VENDOR(s) to whom the BHEL has placed Purchase Order for GOODS/ items/system/package.
- "GOODS": means all or part of the articles, material, equipment supplies including technical documentation, as described in the Purchase Order, to be supplied by VENDOR.
- "PACKER": Packaging Company to whom VENDOR intends to sub-contract the packing in case they do not have own packing capability/facilities .
- "FREIGHT FORWARDER" : Means the Company responsible for performing freight forwarding activities.

5. General Information

	TITLE	SPECIFICATION NO. PE-TS-888-100-A001	
	TECHNICAL SPECIFICATION FOR SEAWORTHY PACKING FOR EXPORT JOBS	VOLUME II B	
		SECTION D	
		REV. NO. 0	DATE 10/08/2010
		SHEET 2	OF 52

The following requirements are intended as minimum requirements, and compliance to these requirements in no way absolves or relieves VENDOR of any responsibility or obligation outlined in the Purchase Order. In all circumstances, the packing will be designed and constructed in order to support GOODS during transportation as well as to prevent the Goods from damage due to impact, extreme climatic conditions, sun and rain. It must be ensured that the delivery of the GOODS to the jobsite by sea, road or air, in good condition.

GOODS shall be export packed in compliance with the best-established practices for international projects, in accordance with the following instructions. In the event of any conflict between these specified requirement and the established practices, specification requirement shall govern.

Due to climatic conditions and the complex transport operation(s), it is essential that protection and packing is of the highest standard. Packing means to efficiently protect the GOODS during the total transport operation; from the moment they leave the factory until they are delivered to the jobsite, including handling operations (loading/unloading) and storage.

When VENDOR do not have packing capabilities/facilities of their own and therefore intends to sub-contract, VENDOR have to inform BHEL/Purchaser of the name and address of proposed PACKER(s) for approval.

6.0 Criteria for Selection of Packaging

Packages are to be made according to categories, described in articles 8.1 to 8.5, depending on the type of materials, their fragility and size.

These categories have been established for the protection of equipment and material during multi-mode transports, i.e.: combination of overland and sea transport; containerization, air transportation.

In a general manner, the GOODS have to be packed in such a way that crates, bundles, pallets can be stored into General Purpose containers, wherever possible.

If VENDOR has any doubt about the correct method of protection or packing, he should contact BHEL/Purchaser in order to mutually agree on the adequate type of packing to be used.

Materials can be classified in following categories

- Hazardous Material
- Non-Hazardous Material
-

Further to above categorisation, non-hazardous materials can be sub- categorised for selection of packing.

6.1 Hazardous Materials

Though handling of hazardous material may is not applicable in the scope of this specification. All hazardous material must be packed in adherence to the detailed requirement relating to packing, marking and labelling set out in the most recent report of the Board's Standard Advisory Committee on the Carriage of Dangerous Goods in Ships for sea freight, and the Restricted Articles Regulations, laid down by the International Air Transport Association for airfreight.

6.2 Non-Hazardous GOODS

The scope of this specification is to provide necessary guidelines for packing for power plant equipment, components, Pipings & Valves, Fittings, other structural items, electrical items, spare parts and erection materials. The procedure is defined in subsequent paragraphs in details in clause no. 8.0.

	TITLE	SPECIFICATION NO. PE-TS-888-100-A001	
	TECHNICAL SPECIFICATION FOR SEAWORTHY PACKING FOR EXPORT JOBS	VOLUME II B	
		SECTION D	
		REV. NO. 0	DATE 10/08/2010
		SHEET 3	OF 52

7.0 Marking Instructions & Despatch details, Storage Code

7.1 Marking Instructions & despatch details

Packages and crates will be marked with indelible black paint, resistant to seawater. Marking must be perfectly legible.

The shipping marks, which will be as per fig-13, shall be stencilled on two sides and one end in clear characters at least 5 centimetres high (where crate size permits, otherwise use optimum size for each package dimension).

When the GOODS are to be shipped in containers then marking may be stencilled on one end only. However, packages must be stowed in a manner that shows these marks.

Crates containing fragile articles must be packed with special precaution against risk of breakage and must be stencilled on all sides "FRAGILE - HANDLE WITH CARE". Where crates are not to be overturned, VENDOR must show on the crates, clear and readily visible identification as per fig-12, to ensure they are kept in the correct position.

Packages/equipment of 2,000 kg or more must be marked with slinging points on all sides, in addition to the centre of gravity marks.

Number packages consecutively i.e. 1 of 10, 2 of 10, etc. Do not duplicate package numbers. VENDOR is responsible for any loss or damage caused by incorrect marking.

All cases/crates shall also be marked with the appropriate international standard graphic symbols for handling as shown in Fig 12.

As a minimum, all cases/crates are to be marked clearly on all four sides with:

- "HANDLE WITH CARE"
- "RIGHT SIDE UP"
- "KEEP DRY"

In the case of packages with a single gross weight totalling 2,000 kg and/or a height of more than 1m, the centre of gravity shall be clearly marked with the symbol on two adjoining sides. For all items of equipment with an eccentric centre of gravity this symbol shall be marked at the bottom, side and top of the package.

The slinging and lashing points shall be marked with a chain symbol.

When packing in cases/crates, these packages shall also have metal corners at the slinging points. (Fig-11)

External front and rear sides of the boxes to be planed for writing instructions.

Dispatch details such as consigner/consignee address, contract and case details, country of origin, port of delivery, stacking instructions shall be written on one side of the boxes. An anodized aluminum plate as per details and specifications given in fig-13 shall be provided on one side of the boxes.

One copy of packing slip wrapped in polyethylene bag covered with aluminum packing slip holder to be nailed on the external surface of the box. One more copy of the packing slip wrapped in polyethylene bag is to be kept inside the box at the pertinent place.

	TITLE	SPECIFICATION NO. PE-TS-888-100-A001	
	TECHNICAL SPECIFICATION FOR SEAWORTHY PACKING FOR EXPORT JOBS	VOLUME II B	
		SECTION D	
		REV. NO. 0	DATE 10/08/2010
		SHEET 4	OF 52

7.2 Storage Code

The type of storage required is required to be specified, it will be shown on each packaging in **RED colour**.

- X Crates or packages to be stored outdoor without covers
- XX Crates or packages to be stored under tarpaulin
- XXX Crates or packages to be stored in covered or enclosed premises
- XXXX Crates or packages which must be stored in air-conditioned premises

8.0 GUIDELINES FOR PACKING GOODS

8.1 In the subsequent paragraphs details of different types of packings for different types of GOODS are defined. Vendor shall make packing details/procedure based on the guidelines and submit for approval.

8.1.1 Packing for Pipe, Fittings, Flanges and Valves, Structural Steel

Particular attention should be brought to pipe, fittings, flanges, valves and structural steel. Packing categories for piping and fittings will differ according to the diameter and wall thickness of these products. VENDOR shall comply with the following established practice.

IMPORTANT NOTE:

Depending on the project schedule and availability of ocean vessels, the piping and structural steel may be shipped in containers. In this event, VENDOR has to arrange the packages in such a way it allows the stuffing into Open Top in gauge containers.

8.1.2 Pipe

Where practicable, pipe lengths shall be limited to 11.8 meters.

All pipes 2" included and below shall be packed in crates. All pipes to be capped and ends sealed with waterproof tape.

Pipes over 2" up to 6", shall be bundled and banded in bundles of uniform length. Bundling is carried out with U-IRON or traversal planks, joined with threaded connecting rods with locknuts. Quantities and strapping positions depend on the lengths, with a 120 cm spacing to prevent distortion. Bundle weight shall not exceed 2,000 kg. All pipes are to be capped and ends sealed with waterproof tape (tape is not necessary if end caps are of the pre-shrunk or self-sealing type).

Pipes larger than 6" shall be shipped as single lengths with the ends capped. End caps are to be of the recessed type to enable the use of soft faced hooks, but still completely sealing the end and also protecting the weld.

All stainless steel piping must be packed separately in wooden crates. Any banding of bundles is to be with the same material.

8.1.3 Pipe Fittings, Flanges and Valves

All pipe fittings, flanges and valves up to 6", are to be packed in cases/crates. For items over 6", these may be fixed securely to a pallet base and enclosed in a crate, for protection. Where valves have actuators attached, rigidity must be ensured for the valve and actuator. The vulnerable parts of the actuator are to be completely protected within a wooden crate.

All stainless steel fittings, flanges and valves of all sizes, must be packed separately in wooden crates. Any strapping is to be with the same material.

8.1.4 Structural Steel

	TITLE	SPECIFICATION NO. PE-TS-888-100-A001	
	TECHNICAL SPECIFICATION FOR SEAWORTHY PACKING FOR EXPORT JOBS	VOLUME II B	
		SECTION D	
		REV. NO. 0	DATE 10/08/2010
		SHEET 5 OF 52	

Structural Steel, reinforcing rods, bars, etc., should be packed in bundles of uniform length. Refer to articles 8.1.2, for strapping requirements. Bundle weight not normally to exceed 2,000 kg. Fabricated structures and structural steelwork, etc, should be bundled and packed using wooden beams and long bolting to secure the load.

8.2 Bundling – Packing Category I

8.2.1 Type of Equipment

Equipment which is not subject to damage by corrosion or mechanical effect, i.e. pipes, piping, structural steel.

Packing category I

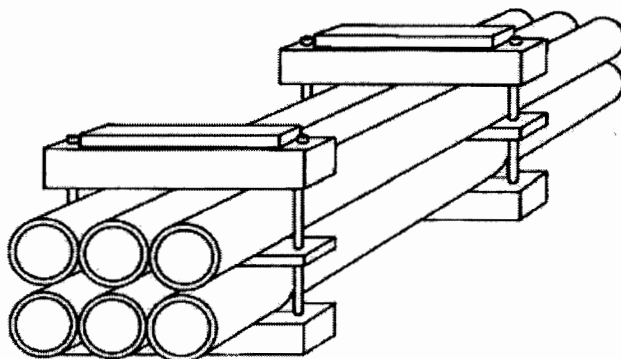

Bundling by U-shaped iron – packing category I A

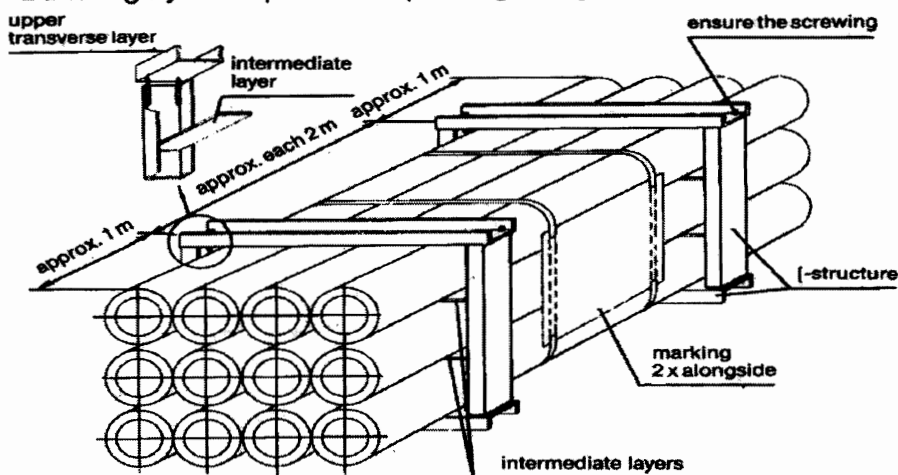

8.2.2 Type of Construction

	TITLE TECHNICAL SPECIFICATION FOR SEAWORTHY PACKING FOR EXPORT JOBS	SPECIFICATION NO. PE-TS-888-100-A001	
		VOLUME II B	
		SECTION D	
		REV. NO. 0	DATE 10/08/2010
		SHEET 6	OF 52

- Bundling has to be effected
- By squared timber and threaded rods.
- With an intermediate layer (threaded on tightening bolts) according to the weight of the package.
- Wedge-shaped timbers must be added at the outer points of lower layer.
- Between the bolts a spacer must be nailed.
- The bolts must be secured (e.g. by locking nut).
- If single parts could protrude, an appropriate protection must be installed (flat iron or plates).
- Bundling with steel straps or PVC straps is not accepted.

8.3 Skids, Square Timber Constructions, Casings – Packing (Category II)

8.3.1 Type of Equipment

Voluminous apparatus, tanks and/or heavy pieces those are not vulnerable to mechanical or corrosive effects.

8.3.2 Type of Construction

- The construction skid can be made of wood or of metal.
- The fastening of the packages on the skid will be made by steel straps (flat iron) which have to be elastically lined, non-slip and securely bolted onto the skids.
- Flange openings have to be closed with gaskets and blind flanges or, if necessary, provided with cover.
- Skid constructions may not be less than the dimensions of the package in length or in width.
- Tanks and apparatus with their own support cradles must be supplied with an anti-slip lining.

PACKING CATEGORY-II

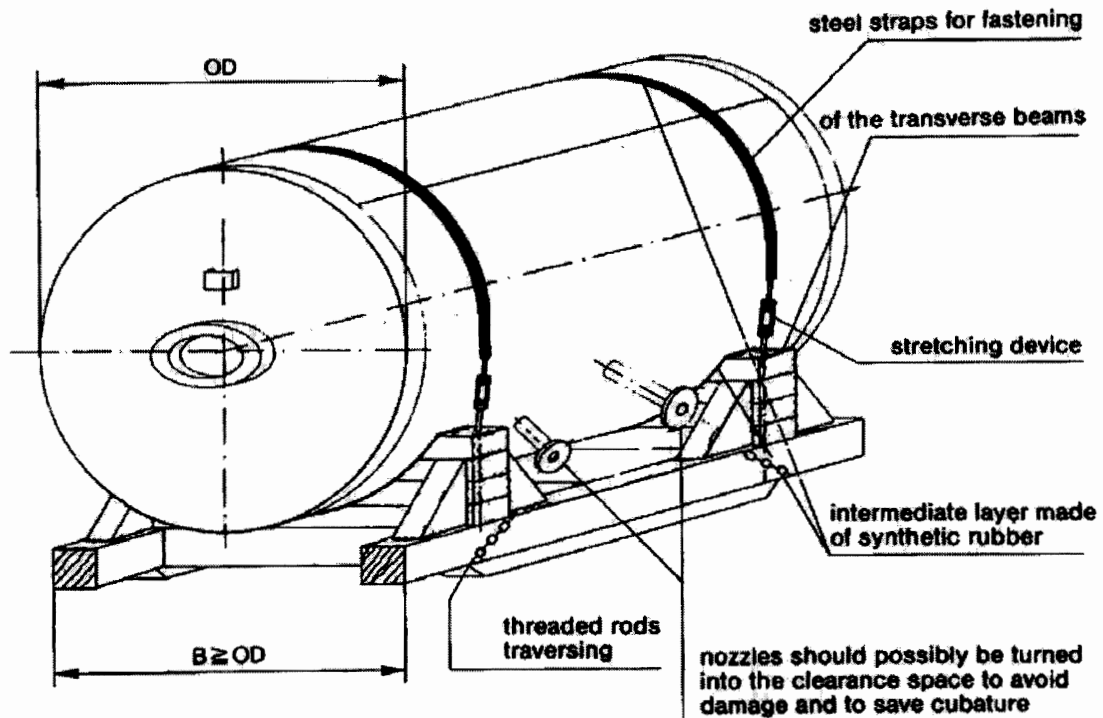

	TITLE	SPECIFICATION NO. PE-TS-888-100-A001	
	TECHNICAL SPECIFICATION FOR SEAWORTHY PACKING FOR EXPORT JOBS	VOLUME II B	
		SECTION D	
		REV. NO. 0	DATE 10/08/2010
		SHEET 7 OF 52	

8.4 Packing of GOODS in Wooden Crates/Cases/Boxes

The construction of wooden crate/cases/boxes shall be as per the details indicated in clause 9.0 & Fig 1 to 11. Details indicated in the sketches for different categories Packing crates/boxes are only for a typical equipment considered for illustration.

8.4.1 Packing Category III

8.4.1.1 Type of Equipment

Fabricated equipment, which cannot be transported on cradles; frame-works, prefabricated piping and fittings, mechanical and electrical assemblies. *This type of packing is recommended where many parts of the equipment/component/assembly are not protruding out.*

8.4.1.2 Type of Construction

The equipment must be safely fastened to the bottom with bolts, possibly by the runners or to be spread in such a manner that no protruding parts are possible. For parts, sensitive to rainwater and/or debris, a protection has to be made by a foil cap.

If it is possible that single part could protrude through the front/back side wall, they shall be closed completely. The marking of the package shall be done on plywood plates at the prescribed sides.

Packing Category III

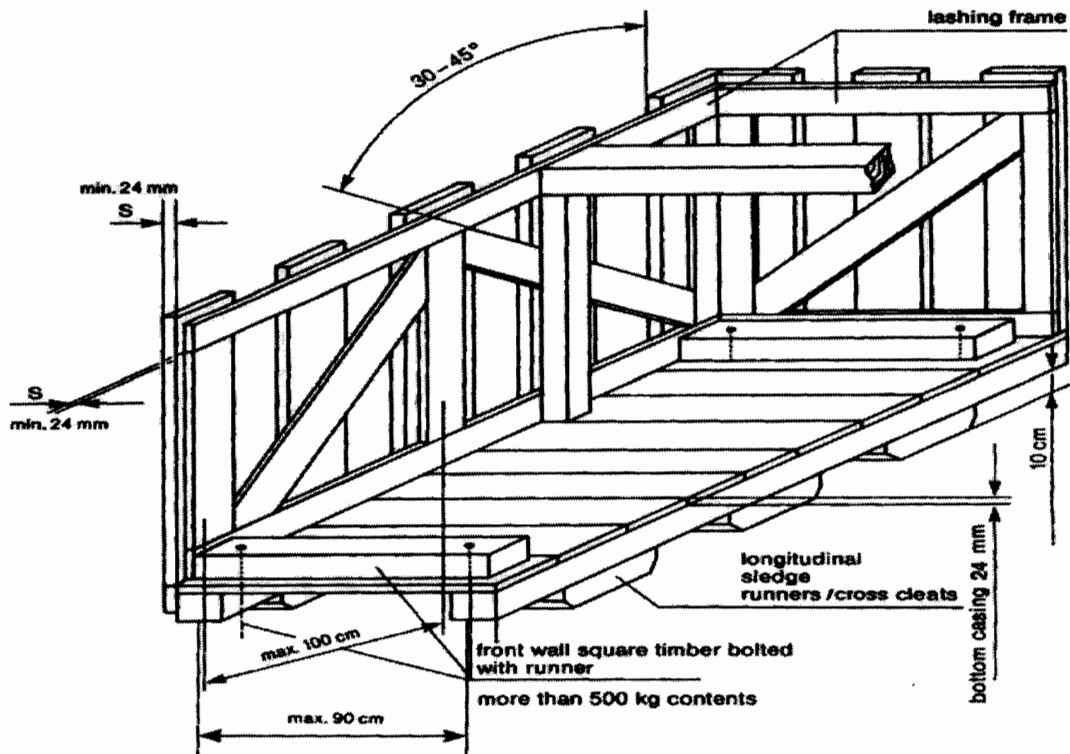

	TITLE	SPECIFICATION NO. PE-TS-888-100-A001	
	TECHNICAL SPECIFICATION FOR SEAWORTHY PACKING FOR EXPORT JOBS	VOLUME II B	
		SECTION D	
		REV. NO. 0	DATE 10/08/2010
		SHEET 8	OF 52

8.4.2 Cases with Lining – Packing Category IV

8.4.2.1 Type of Equipment

Recommended for equipment and mechanical parts Equipment sensitive to mechanical damage or parts and components that are particularly at risk of theft or loss; pumps, elbows, flanges, fittings, tools, erection materials, etc.

8.4.2.2 Type of Construction

The same type of construction as article 8.4.1.2, but with all sides completely boarded without space between the boards. Sides to be provided with waterproof lining; fabric-reinforced waterproof tar paper or polyethylene-foils resistant to ultraviolet rays can be used. Polyethylene-foil shall be fixed under the lid cover to avoid penetration of water. At weights of more than 500 kg the longitudinal runner must be bolted to the front all square timber. For ventilation inside the case, an opening in the waterproof lining must be placed between the diagonal battens and diagonal joists.

Packing Category IV

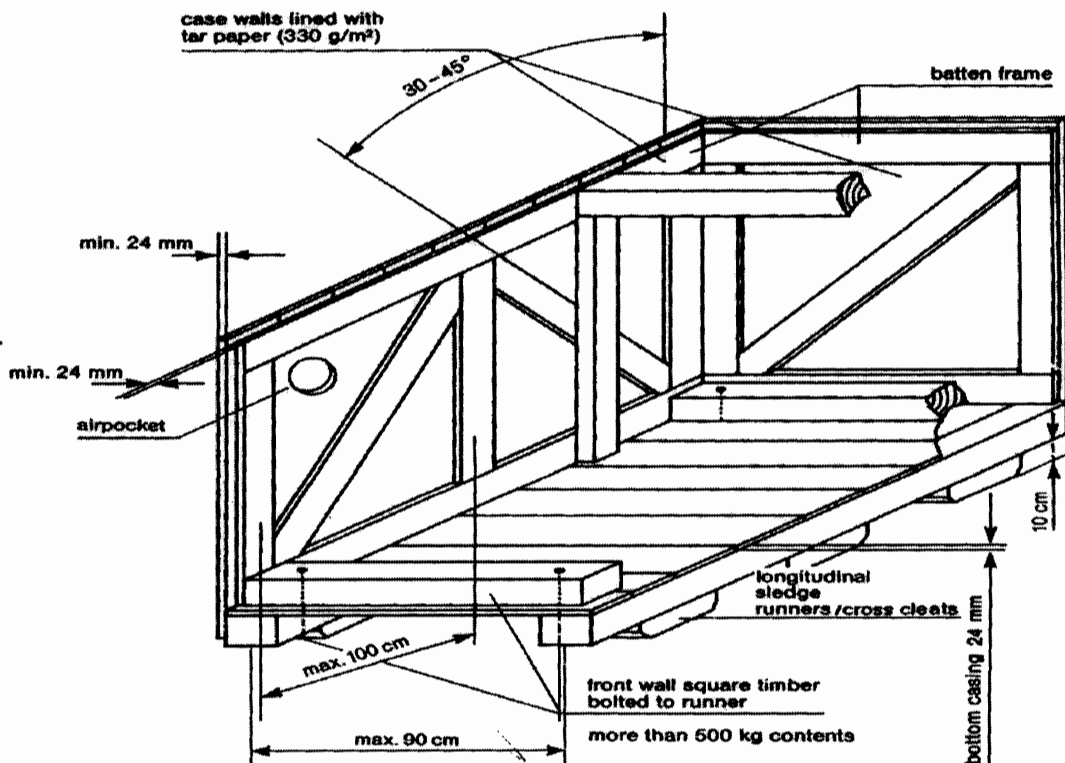

8.4.3 Cases with Alternative Surface Materials

8.4.3.1 Plywood Box – Packing Category IV A

	TITLE	SPECIFICATION NO. PE-TS-888-100-A001	
	TECHNICAL SPECIFICATION FOR SEAWORTHY PACKING FOR EXPORT JOBS	VOLUME II B	
		SECTION D	
		REV. NO. 0	DATE 10/08/2010
		SHEET 9 OF 52	

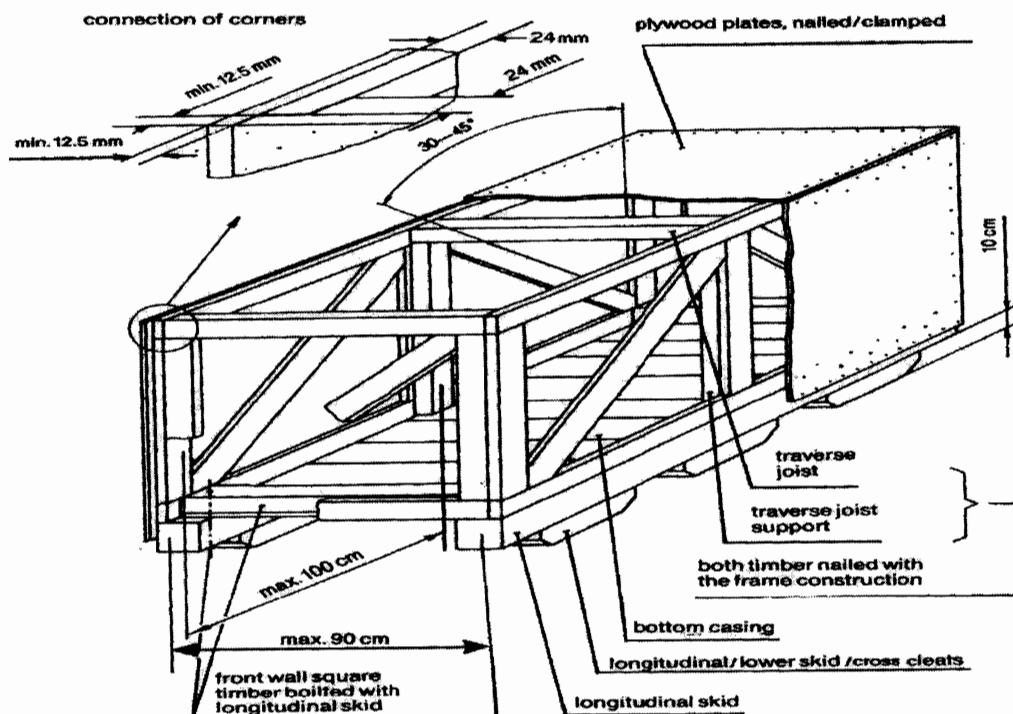

Case constructed of 5 layers of watertight, glued plywood with a total thickness of 12.5 mm. The frame must be constructed from minimum 24 mm timber or as per guide lines given above against clause 8.0, Fig 1 to 11 and must be suitable for the weight and nature of the parts to be packed. Planed square timber must be bolted with longitudinal skid and covered with diagonal joists. If applicable, construction of the cover and sides is to include diagonal bracing. Covers consisting of several layers of plywood are to be sealed with durable elastic putty or additional water-resistant sheets to be fixed.

8.4.4 Case with Barrier Material – Polyethylene Foil – Packing Category V

8.4.4.1 Type of Equipment

Sensitive equipment, simple electrical equipment, insulation materials, fire-resistant materials, with non-corrosion- guarantee for a period up to twelve (12) months.

8.4.4.2 Type of Construction

Preservation by welding in polyethylene-foil with addition of desiccants and if necessary, application of non-corrosive contact agents, otherwise, type of construction as indicated in article 8.4.2.2.

Additional marking:

- Case with desiccants.

8.4.5 Case with Barrier Material – Aluminium Compound Foil – Packing Category VI

8.4.5.1 Type of Equipment

	TITLE	SPECIFICATION NO. PE-TS-888-100-A001	
	TECHNICAL SPECIFICATION FOR SEAWORTHY PACKING FOR EXPORT JOBS	VOLUME II B	
		SECTION D	
		REV. NO. 0	DATE 10/08/2010
		SHEET 10	OF 52

Electrical equipment such as, switchboards, electric motors, sensitive equipment, with non-corrosion guarantee, for a period up to twelve (12) months.

8.4.5.2 Type of Construction

Type of construction as indicated in article 8.4.2.2. Preservation by sealing an aluminium compound foil, with the addition of desiccants. Humidity indicators, if required and installed in the barrier wrapping, shall allow easy control from the outside.

Additional marking:

- Case with desiccants.

Packing Category V/VI

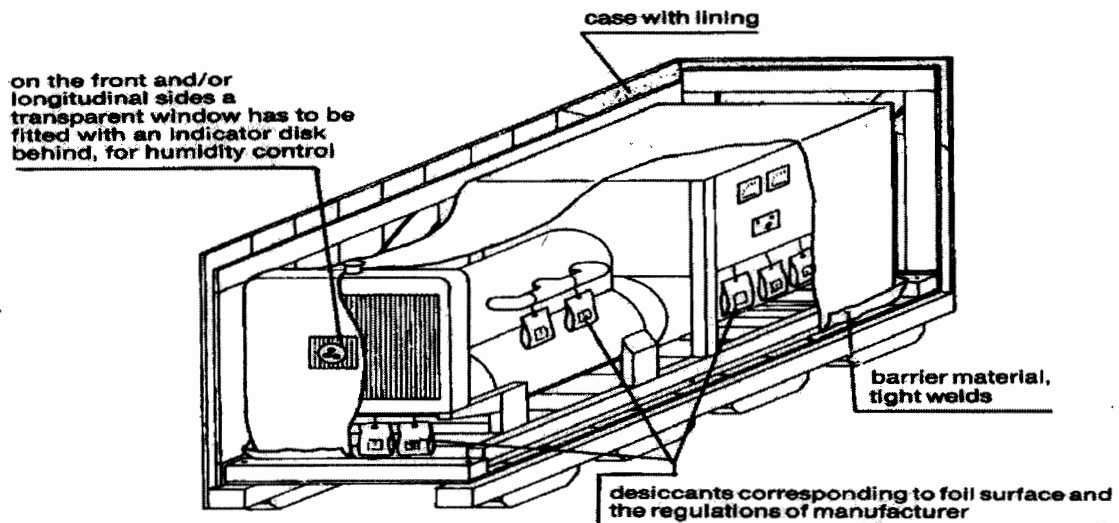

8.4.6 Double Case – Packing Category VII

8.4.6.1 Type of Equipment

GOODS which are of high sensitivity to shock, impact and vibration, for instance, special electrical equipment like computers, switchboards, laboratory instruments

8.4.6.2 Type of Construction

Case construction as indicated in article 8.4.2.2, with additional floating inner packing (case-in-case principle), padding corresponding to weight and sensitiveness. Preservation by sealing in aluminium compound foil with the addition of desiccants. The inner case has to be made of plywood or equivalent material with a thickness of 8-12 mm, depending on the weight of the GOODS to be packed. The inner buckles and/or frame borders have to be dimensioned so that the full stability of the inside case will be reached and no twisting is possible. The inner sides of the inside case will be lined with bituminous kraft paper on all sides (except bottom).

	TITLE	SPECIFICATION NO. PE-TS-888-100-A001	
	TECHNICAL SPECIFICATION FOR SEAWORTHY PACKING FOR EXPORT JOBS	VOLUME II B	
		SECTION D	
		REV. NO. 0	DATE 10/08/2010
		SHEET 11	OF 52

8.4.7 Cable Drum – Packing Category VIII

8.4.7.1 Type of Equipment

All type of cables, wires, ropes, hoses.

8.4.7.2 Type of Construction

For all type of cables refer clause no. 11.1. For other items (wires, ropes, hoses) new or practically new drums are to be used. Planking of the e drums by use of boards, thickness minimum 20 mm, with additional double steel strapping, nailed, and carefully preserved/ protected cable ends prior to packing.

8.4.8 Hazardous Materials – Packing Category IX

8.4.8.1 Type of Equipment

Hazardous materials according to the law are explosives, compressed gases, liquefied gases dissolved under pressure or deeply refrigerated, flammable liquids, flammable solids: substances liable to spontaneous combustion; substances which, on contact with water, emit flammable gases, oxidizing substances, organic peroxides, poisonous (toxic) and infectious substances; radioactive materials, corrosives, miscellaneous dangerous goods.

8.4.8.2 Type of Construction

Hazardous materials shall always be packed and documented separately from any other material. Selection of packaging materials, execution of packing and marking as well as documentation shall always be in compliance with the applicable laws and regulations. Any certificates required for transportation or for authorities to be supplied before shipment of the GOODS.

8.4.9 Wooden Floor as a Transport Support – Packing Category X

8.4.9.1 Type of Equipment

Any materials to be stuffed in containers or on flat racks and that are not stowed on standard pallets or otherwise suitably packed

8.4.9.2 Type of Construction

- Longitudinal internal square timbers bolted to the front wall runners, longitudinal skid.
- Maximum distance between longitudinal runners 90 cm (middle to middle of the runner).
- Full boarding of the floor.
- Attaching of lifting lugs and/or iron ropes for lifting/pulling the units off the transport equipment.
- If applicable, preservation of the equipment by sealing in polyethylene-foil or aluminium compound foil and the addition of desiccants.

8.5 Air Transport Packing

8.5.1 General

Certain types of material may have to be shipped by air from their country of origin. This means of transport will be exceptional, and will be used only:

- For GOODS, which are highly sensitive to shock or vibrations, such as computers, electronic instruments, or those of small dimensions and weight.
- For GOODS urgently required at the module yard(s) and/or jobsite.

	TITLE	SPECIFICATION NO. PE-TS-888-100-A001		
	TECHNICAL SPECIFICATION FOR SEAWORTHY PACKING FOR EXPORT JOBS	VOLUME II B		
		SECTION D		
		REV. NO. 0	DATE 10/08/2010	
		SHEET 12	OF	52

8.5.2 Type of Packing

Depending on the goods to be packed, VENDOR may use one of the following types:

- A triple-corrugated cardboard container made with waterproofed glue and a barrier layer of polyethylene on the outsides to keep out humidity.
- Wooden/cardboard packing cases: the wood being used for the framework and base of the cases, waterproofed triple-corrugated cardboard being used for the sides and top. These cases are of the "Bell" type, and used for material of small or medium dimensions.
- For larger dimensions, plywood cases are acceptable. The timber characteristics, cross-sections and thickness will be systematically determined by the nature of the loads to be packed.

8.5.3 Dimensions

In order to optimize the existing transport facilities (passenger or cargo aircraft), the dimensions of:

- Triple-corrugated containers.
 - Wooden/cardboard packing cases.
 - Plywood cases.
- Are to be adapted to pallets used for air transportation.

9.0 Detailed specification for Wooden Crates/Boxes/Cases and other packing materials

9.1 Technical specification for wood

The wood shall be Fir, Chir, Silver Oak (Gravillea Robusta), chemically treated mango and Pinewood with moisture content not exceeding 50%. The wood shall have flexural and compressive strength, stiffness, shock absorption and nail retention properties. The wood shall be free from common defects such as warp, bone, twist, knot, cracks, splits, end splits, bend, visible sign of infection and any kind of decay caused by insects or fungus, etc. Surface cracks with maximum depth of 3mm are permissible. A continuous crack of any depth all along the length is not allowed.

9.2 Chemical Treatment of Wood:

The wood shall be chemically treated to provide protection against deterioration due to fungi and attack by termites, borers, marine organism and any other kind of infection. It shall be treated only after final processing like cutting, planning, joint grooving, etc.

9.3 TYPE, DESIGN & DIMENSION OF WOODEN PACKING CASES:

9.3.1 PACKING OF EQUIPMENTS

Various mechanical, electrical and C&I equipment e.g. Pumps, motors, equipment skids, heat exchangers, control panels, switch gears, transformers, etc. shall be wrapped in weather proof packing and then secured in wooden packing cases. The construction of wooden packing cases/crates shall be as per details given below and also given in figure 1 to 11.

9.3.1.1 Bottom Frame

	TITLE	SPECIFICATION NO. PE-TS-888-100-A001	
	TECHNICAL SPECIFICATION FOR SEAWORTHY PACKING FOR EXPORT JOBS	VOLUME II B	
		SECTION D	
		REV. NO. 0	DATE 10/08/2010
		SHEET 13	OF 52

The construction of bottom frame shall be as per Fig-2. The No. of slides/runners for bottom frames shall be selected depending upon the weight and overall dimensions of the load to be carried. The equipment shall be secured by fixing their base frame/plate with the help of bolt and nuts etc. to bottom frame of the wooden packing cases/crates. The equipment not provided with base frame/plate like cylindrical vessels, etc to be secured to the bottom frame of the wooden cases with "C" clamps fabricated from steel channels/ angle iron.

9.3.1.2 TOP FRAME

The construction of top frame shall be as per fig-3.

9.3.1.3 END PANELS

The dimension of the end and lateral panels shall be calculated according to overall dimensions of the items to be packed. Diagonal braces shall be used for packing cases having height exceeding 500mm. Details of bracings shall be as per fig 5 to 9.

9.3.1.4 Sling Plate

To facilitate lifting of cases, longitudinal under slide boards shall be fixed. To avoid damage to the box while lifting sling plates shall be provided. Refer fig-11.

9.3.1.5 Angle Iron Cleats

Angle iron cleats shall be used for strengthening the joints as indicated in fig-10

9.3.1.6 Other Requirements

- The thickness of planks for top, bottom, side and end panels shall be at least 25mm. Planks used for this purpose shall be joined with each other by tongue and groove joint. The groove dimension shall be such that tongue fits tightly into groove to make the joint.
- Runners/slides, traverse bars, etc shall be of single length i.e. without any joint. Planks for sheathing, diagonal bracing etc shall also be of single length up to 2400mm, proper jointing is permitted for planks for sheathing and diagonal bracings.
- Each equipment to be individually covered with double polyethylene petticoat. Sheet thickness of polythene sheet shall not be less than 0.175 mm (175 microns). The sealing shall be such so as not to allow moisture inside.
- The inner surface of 4 sides of shooks shall be nailed with bituminized water proof craft paper. Wherever 2 pieces of kraft paper are used, joint shall have an overlap of minimum 20 mm.
- All the inner sides of the box shall be nailed with bitumen coated HESSIAN POLYTHYLENE KRAFT PAPER. For top frame it shall project on all sides by 100mm and shall be nailed on sides. Wherever 2 pieces of kraft paper are used, joint shall have an overlap of minimum 20 mm.
- For delicate equipment like control panels and switchgears, lighting panels and lighting transformers, suitable cushioning material like rubberised coir (min. 50 mm thick and 100 mm wide) shall be provided on their bottom support and the gap between the panel and casing

	TITLE	SPECIFICATION NO. PE-TS-888-100-A001	
	TECHNICAL SPECIFICATION FOR SEAWORTHY PACKING FOR EXPORT JOBS	VOLUME II B	
		SECTION D	
		REV. NO. 0	DATE 10/08/2010
		SHEET 14	OF 52

shall be filled with rubberized coir with distance between consecutive supports less than 500 mm (ref fig15). For other equipment suitable support from sides of the casing shall be provided.

- Switchgear cubicles, control panels and control desks shall be packed and shipped in separate convenient sections. The components e.g. circuit breakers relays and instruments etc. which are removed from panels for shipping purpose and shall be separately packed and shipped as per packing instructions in clause 10.4.
- Packing case for control panels and switchgear panels shall be finally covered with GI sheet of minimum thickness of 0.4mm.
- Packing cases shall be bound at edges by nailing MS clamps/brackets at sufficient intervals. Further heavier boxes shall be strapped with C clamps (ref fig-4) fabricated from steel channels/angles and lighter boxes shall be strapped with hoop iron strips.
- Silica gel is used for this purpose to protect contents over sufficiently long time from corrosion. Silica gel shall be indicating type confirming to IS-304 (1979) packed in cotton bags placed at different positions inside the packing for absorbing moisture and shall not come into directly contact with equipment/material inside the package. The quantity of silica gel shall be adequate for storage period of one year, however it shall not be less than 4 gm. per ltr. Volume of case subject to minimum 400 gm. Per case.

	TITLE	SPECIFICATION NO. PE-TS-888-100-A001	
	TECHNICAL SPECIFICATION FOR SEAWORTHY PACKING FOR EXPORT JOBS	VOLUME II B	
		SECTION D	
		REV. NO. 0	DATE 10/08/2010
		SHEET 15	OF 52

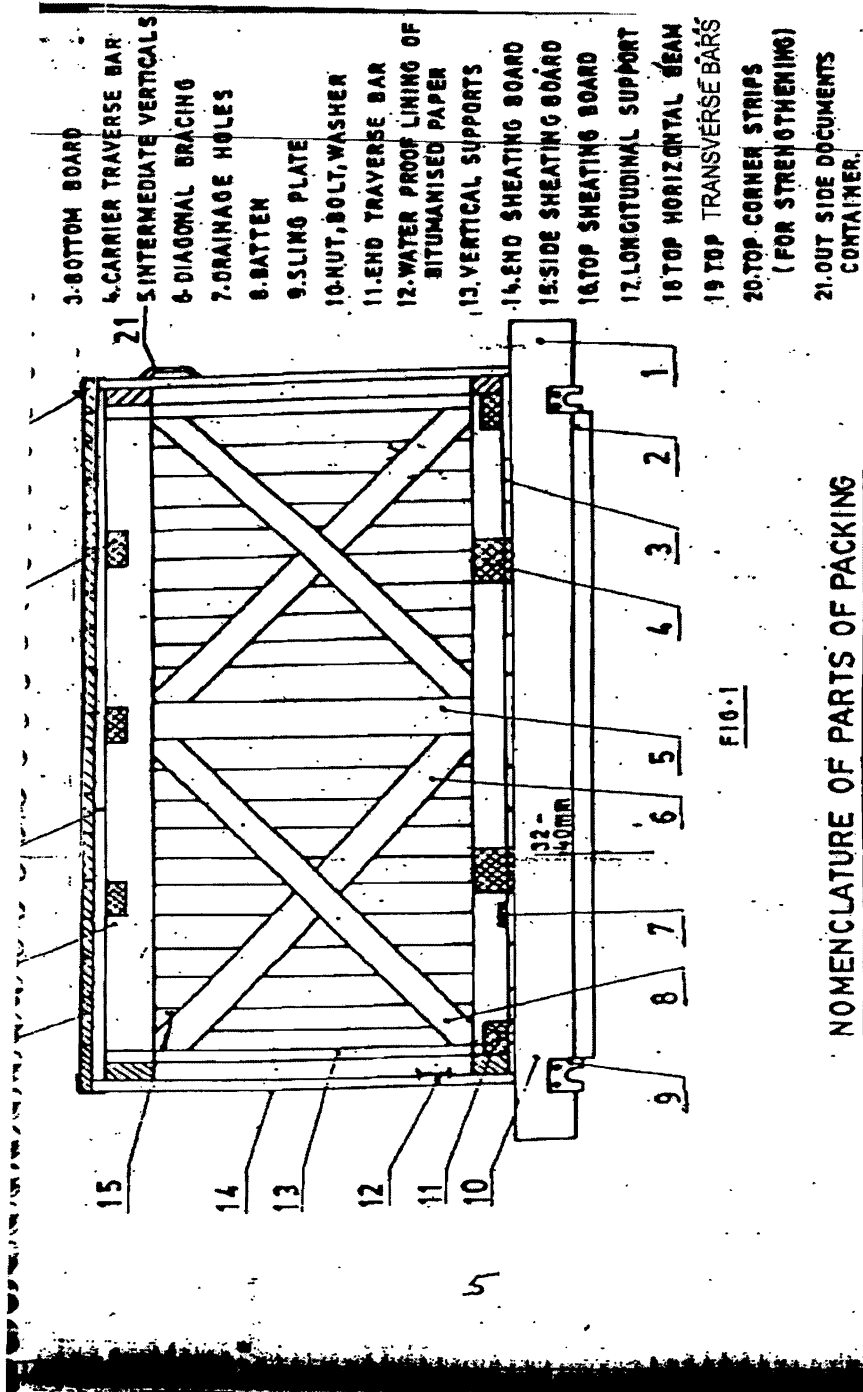

- 3. BOTTOM BOARD
- 4. CARRIER TRAVERSE BAR
- 5. INTERMEDIATE VERTICALS
- 6. DIAGONAL BRACING
- 7. DRAINAGE HOLES
- 8. BATTEN
- 9. SLING PLATE
- 10. NUT, BOLT, WASHER
- 11. END TRAVERSE BAR
- 12. WATER PROOF LINING OF BITUMANISED PAPER
- 13. VERTICAL SUPPORTS
- 14. END SHEATHING BOARD
- 15. SIDE SHEATHING BOARD
- 16. TOP SHEATHING BOARD
- 17. LONGITUDINAL SUPPORT
- 18. TOP HORIZONTAL BEAM
- 19. TOP TRANSVERSE BARS
- 20. TOP CORNER STRIPS (FOR STRENGTHENING)
- 21. OUT SIDE DOCUMENTS CONTAINER.

	TITLE	SPECIFICATION NO. PE-TS-888-100-A001	
	TECHNICAL SPECIFICATION FOR SEAWORTHY PACKING FOR EXPORT JOBS	VOLUME II B	
		SECTION D	
		REV. NO. 0	DATE 10/08/2010
		SHEET 16	OF 52

BOTTOM FRAME ARRANGEMENTS

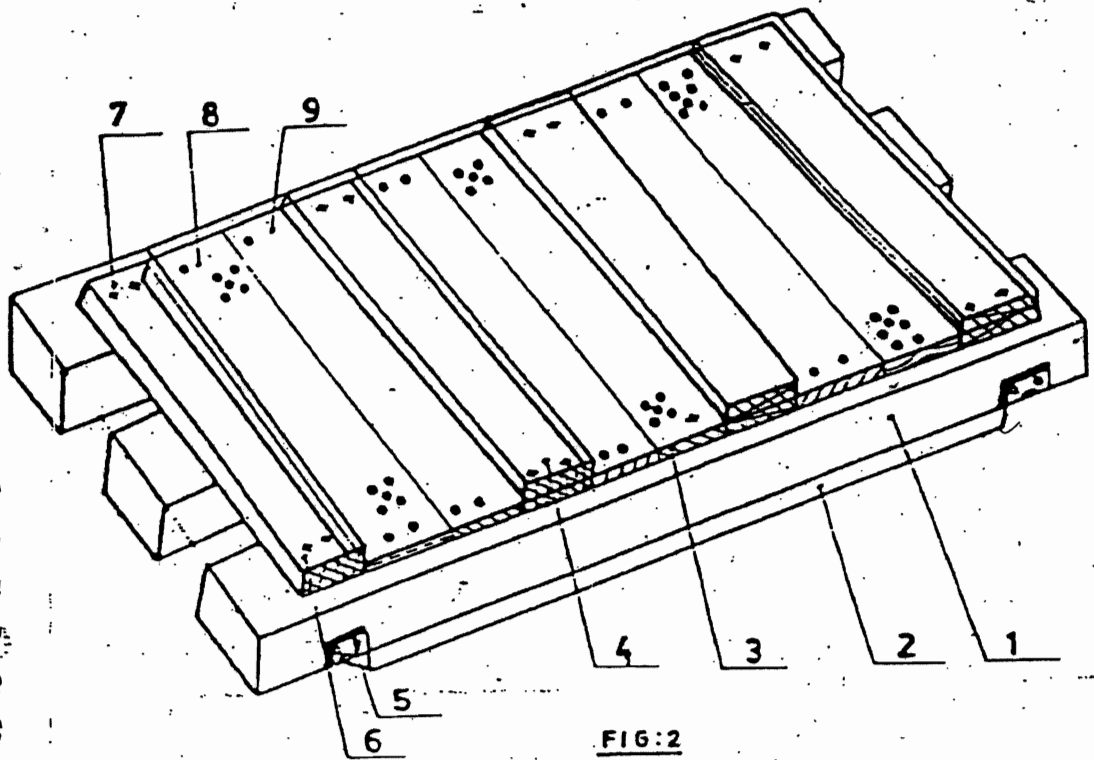

Nos. of slides: Minimum 2 Nos.
 For length more than 1800 mm or
 load more than 1000kg, nos. of
 slides shall be minimum 3 Nos.
 For dimensions of slides, refer Table 1
 Cross section of end traverse bar; 100 x 100 mm.
 (minimum)

- 1. SLIDE
- 2. UNDER SLIDE BOARD
- 3. BOTTOM BOARD
- 4. CARRIER TRAVERSE BAR
- 5. SLING PLATE
- 6. TRAVERSE BAR
- 7. BOLT, NUT & WASHER
- 8. DRAINAGE HOLES
- 9. NAILS

027

	TITLE	SPECIFICATION NO. PE-TS-888-100-A001	
	TECHNICAL SPECIFICATION FOR SEAWORTHY PACKING FOR EXPORT JOBS	VOLUME II B	
		SECTION D	
		REV. NO. 0	DATE 10/08/2010
SHEET 17 OF 52			

TOP FRAME ARRANGEMENT

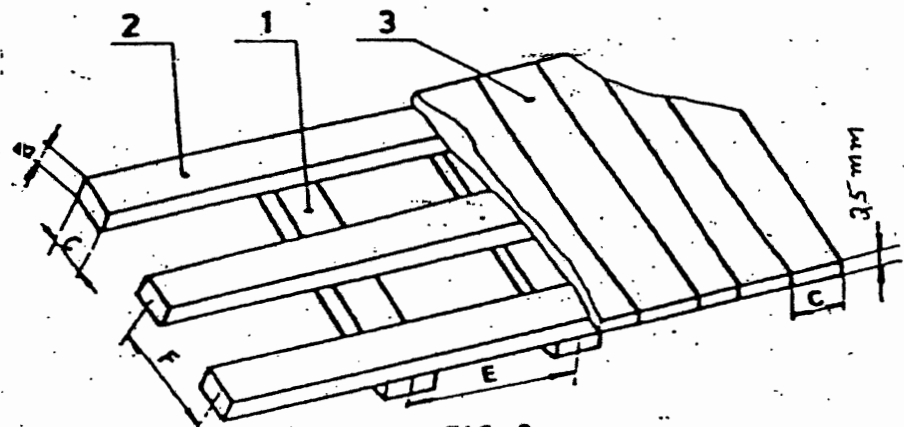
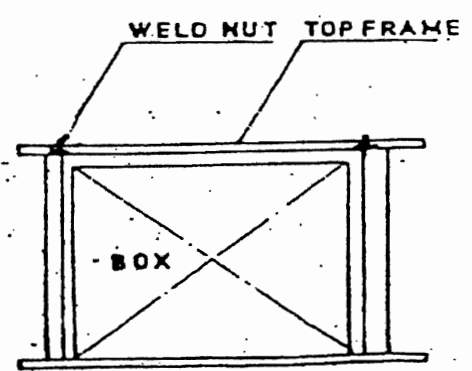
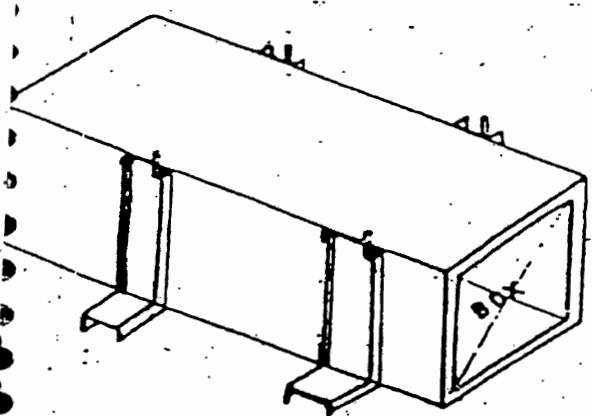



FIG-3

F : 700 to 1000 mm
 E : 500 to 900 mm
 : 30x100 mm.

- 1 - Traverse Bars
- 2 - Horizontal Soans
- 3 - Top Board

ARRANGEMENT OF C-CLAMPS AROUND CASES



	TITLE	SPECIFICATION NO. PE-TS-888-100-A001	
	TECHNICAL SPECIFICATION FOR SEAWORTHY PACKING FOR EXPORT JOBS	VOLUME II B	
		SECTION D	
		REV. NO. 0	DATE 10/08/2010
		SHEET 18	OF 52

**ARRANGEMENT OF DIAGONAL BRACING AND
HORIZONTAL SUPPORT**

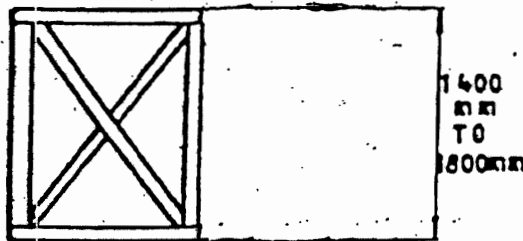

FIG: 6

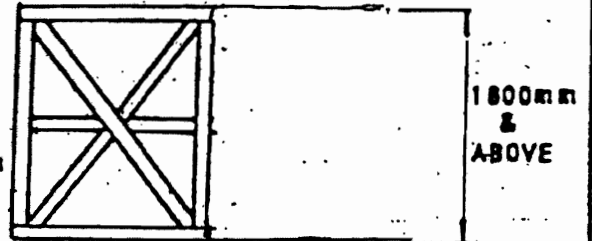

FIG: 8

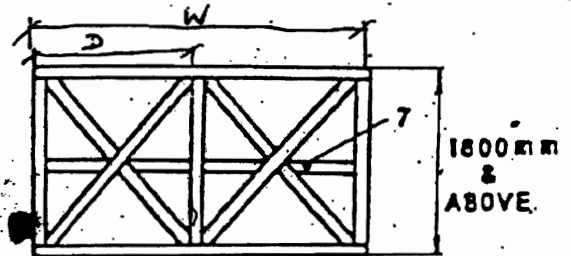

FIG: 7

7- Middle Horizontal Support

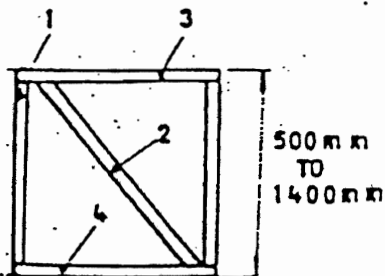

FIG: 5

1- Vertical Support

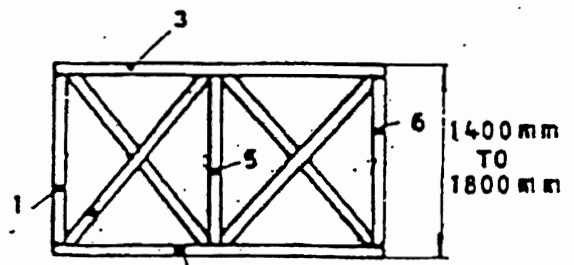

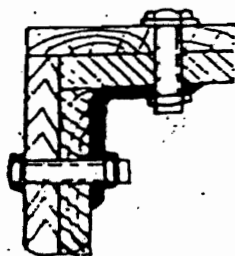
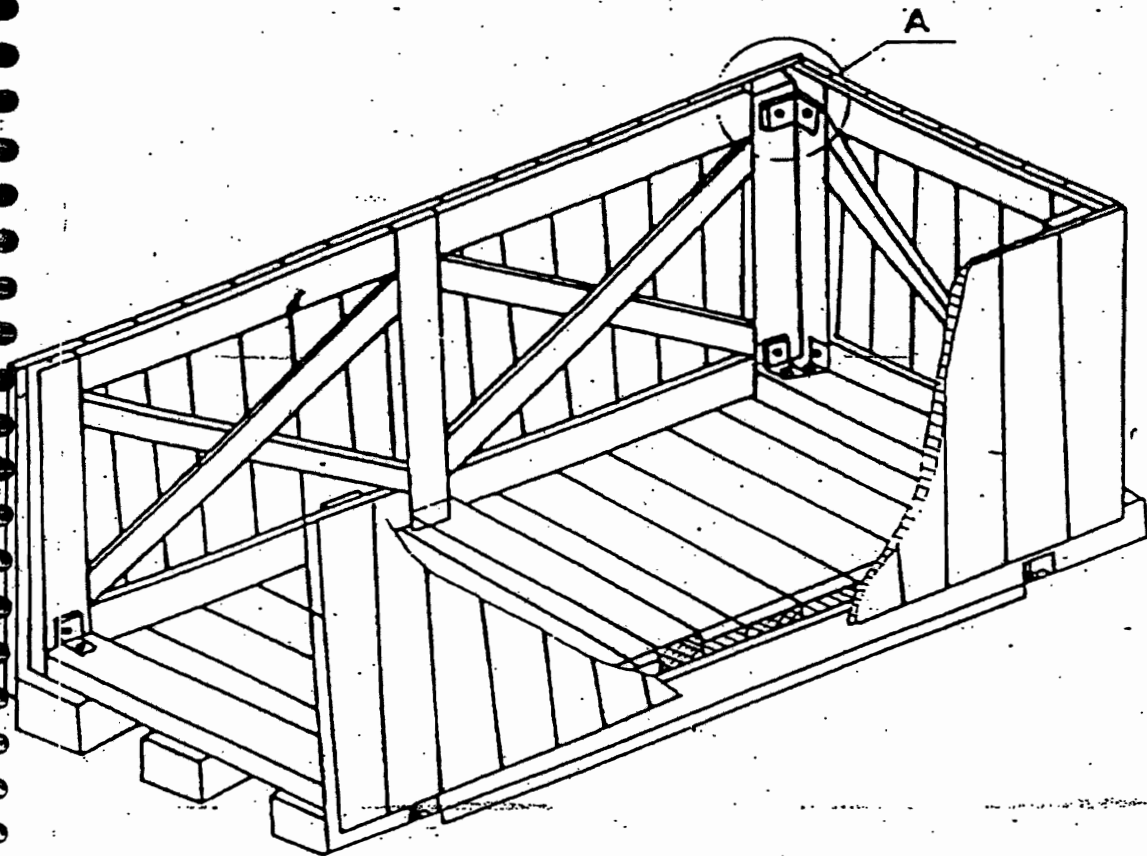

FIG: 7

1, 5, 6 - Vertical Support

	TITLE	SPECIFICATION NO. PE-TS-888-100-A001
	TECHNICAL SPECIFICATION FOR SEAWORTHY PACKING FOR EXPORT JOBS	VOLUME II B
		SECTION D
		REV. NO. 0 DATE 10/08/2010
		SHEET 19 OF 52

ARRANGEMENT OF PACKING CASE



DETAIL-A

HOLE DIAMETER
MUST CONFORM
TO BOLT DIA

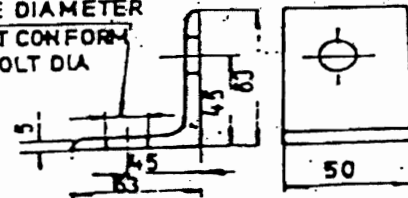

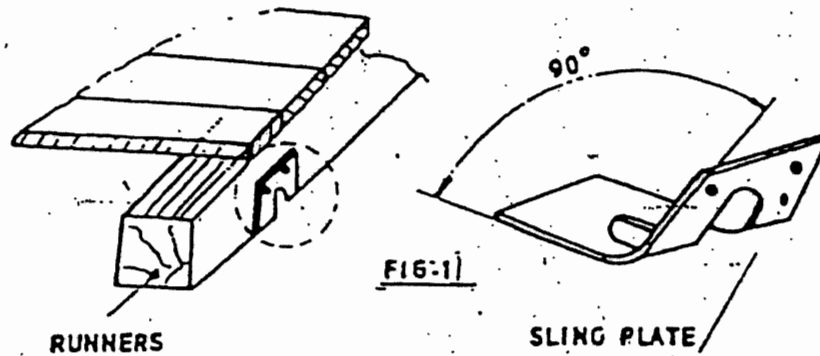

FIG:10

	TITLE	SPECIFICATION NO. PE-TS-888-100-A001
	TECHNICAL SPECIFICATION FOR SEAWORTHY PACKING FOR EXPORT JOBS	VOLUME II B
		SECTION D
		REV. NO. 0 DATE 10/08/2010
		SHEET 20 OF 52

ARRANGEMENT OF SLING & PLATE ON

CASES











	TITLE TECHNICAL SPECIFICATION FOR SEAWORTHY PACKING FOR EXPORT JOBS	SPECIFICATION NO. PE-TS-888-100-A001					
		VOLUME II B					
		SECTION D					
		REV. NO. 0			DATE 10/08/2010		
		SHEET 22		OF		52	

Table-2



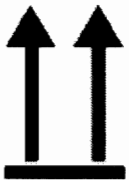



End and side panels	Width of the panel "W"	Distance between longitudinal support (Dimension "D")						
		600	800	1000	1200	1400	1600	1800
		Cross section b x c				Item 1 to 7		
Fig- 5 to Fig-9	600 to 1200	30	30	30	30	30	30	30
		X	X	X	X	X	X	X
	1201 to 1600	100	100	100	130	130	130	130
		X	X	X	X	X	X	X
	1601 to 2000	30	30	30	30	30	30	30
		X	X	X	X	X	X	X
	2001 to 3000	130	130	130	130	130	130	130
		X	X	X	X	X	X	X
	3001 to 4000	30	30	30	30	30	30	40
		X	X	X	X	X	X	X
		130	130	130	130	130	130	150
		X	X	X	X	X	X	X
		40	40	40	40	40	40	40
		X	X	X	X	X	X	X
		150	150	150	150	150	150	150
		X	X	X	X	X	X	X

	TITLE	SPECIFICATION NO. PE-TS-888-100-A001	
	TECHNICAL SPECIFICATION FOR SEAWORTHY PACKING FOR EXPORT JOBS	VOLUME II B	
		SECTION D	
		REV. NO. 0	DATE 10/08/2010
		SHEET 23	OF 52

INDICATION MARKS ON CASES/BOXES/CRATES

Designation	Symbol	Explanation
Fragile, Handle with care		The symbol should be applied to easily broken cargoes. Cargoes marked with this symbol should be handled carefully and should never be tipped over or slung.
Use no hooks		Any other kind of point load should also be avoided with cargoes marked with this symbol. The symbol does not automatically prohibit the use of the plate hooks used for handling bagged cargo.
Top		The package must always be transported, handled and stored in such a way that the arrows always point upwards. Rolling, swinging, severe tipping or tumbling or other such handling must be avoided.
Keep away from heat (solar radiation)		Compliance with the symbol is best achieved if the cargo is kept under the coolest possible conditions. In any event, it must be kept away from additional sources of heat. It may be appropriate to enquire whether prevailing or anticipated temperatures may be harmful.
Protect from heat and radioactive sources		Stowage as for the preceding symbol. The cargo must additionally be protected from radioactivity.
Sling here		The symbol indicates merely where the cargo should be slung, but not the method of lifting. If the symbols are applied equidistant from the middle or center of gravity, the package will hang level if the slings are of identical length. If this is not the case, the slinging equipment must be shortened on one side.
Keep dry		Cargo bearing this symbol must be protected from excessive humidity and must accordingly be stored under cover. If particularly large or bulky packages cannot be stored in warehouses or sheds, they must be carefully covered with tarpaulins.

	TITLE	SPECIFICATION NO. PE-TS-888-100-A001	
	TECHNICAL SPECIFICATION FOR SEAWORTHY PACKING FOR EXPORT JOBS	VOLUME II B	
		SECTION D	
		REV. NO. 0	DATE 10/08/2010
		SHEET 24	OF 52

Center of gravity		This symbol is intended to provide a clear indication of the position of the center of gravity. To be meaningful, this symbol should only be used where the center of gravity is not central. The meaning is unambiguous if the symbol is applied onto two upright surfaces at right angles to each other.
No hand truck here		The absence of this symbol on packages amounts to permission to use a hand truck on them.
Stacking limitation		The maximum stacking load must be stated as "... kg max.". Since such marking is sensible only on packages with little loading capacity, cargo bearing this symbol should be stowed in the uppermost layer.
Clamp here		Stating that the package may be clamped at the indicated point is logically equivalent to a prohibition of clamping anywhere else.
Temperature limitations		According to regulations, the symbol should either be provided with the suffix "...°C" for a specific temperature or, in the case of a temperature range, with an upper ("...°C max.") and lower ("...°C min.") temperature limit. The corresponding temperatures or temperature limits should also be noted on the consignment note.
Do not use forklift truck here		This symbol should only be applied to the sides where the forklift truck cannot be used. Absence of the symbol on other sides of the package amounts to permission to use forklift trucks on these sides.
Electrostatic sensitive device		Contact with packages bearing this symbol should be avoided at low levels of relative humidity, especially if insulating footwear is being worn or the ground/floor is nonconductive. Low levels of relative humidity must in particular be expected on hot, dry summer days and very cold winter days.

	TITLE	SPECIFICATION NO. PE-TS-888-100-A001	
	TECHNICAL SPECIFICATION FOR SEAWORTHY PACKING FOR EXPORT JOBS	VOLUME II B	
		SECTION D	
		REV. NO. 0	DATE 10/08/2010
	SHEET 25	OF 52	

Do not destroy barrier		<p>A barrier layer which is (virtually) impermeable to water vapor and contains desiccants for corrosion protection is located beneath the outer packaging. This protection will be ineffective if the barrier layer is damaged. Since the symbol has not yet been approved by the ISO, puncturing of the outer shell must in particular be avoided for any packages bearing the words "Packed with desiccants".</p>
Tear off here		<p>This symbol is intended only for the receiver.</p>

FIG-12

	TITLE	SPECIFICATION NO. PE-TS-888-100-A001	
	TECHNICAL SPECIFICATION FOR SEAWORTHY PACKING FOR EXPORT JOBS	VOLUME II B	
		SECTION D	
		REV. NO. 0	DATE 10/08/2010
SHEET 26 OF 52			



		BHEL-PEM-DELHI-INDIA			
CONSIGNEE					
MATERIAL					
CUSTOMER REF.			MO. NO.		
DESPATCH ADVICE NOTE NO.			CASE NO.		
DIMENSIONS(MM) LXBXH			NET WT -KGS	GROSS WT -KGS	
SPECIAL INSTRUCTIONS	HANDLE WITH CARE -- KEEP DRY DO NOT DROP -- DO NOT TILT				

FIG-13: MARKING PLATE

	TITLE	SPECIFICATION NO. PE-TS-888-100-A001
	TECHNICAL SPECIFICATION FOR SEAWORTHY PACKING FOR EXPORT JOBS	VOLUME II B
		SECTION D
		REV. NO. 0 DATE 10/08/2010
SHEET 27 OF 52		

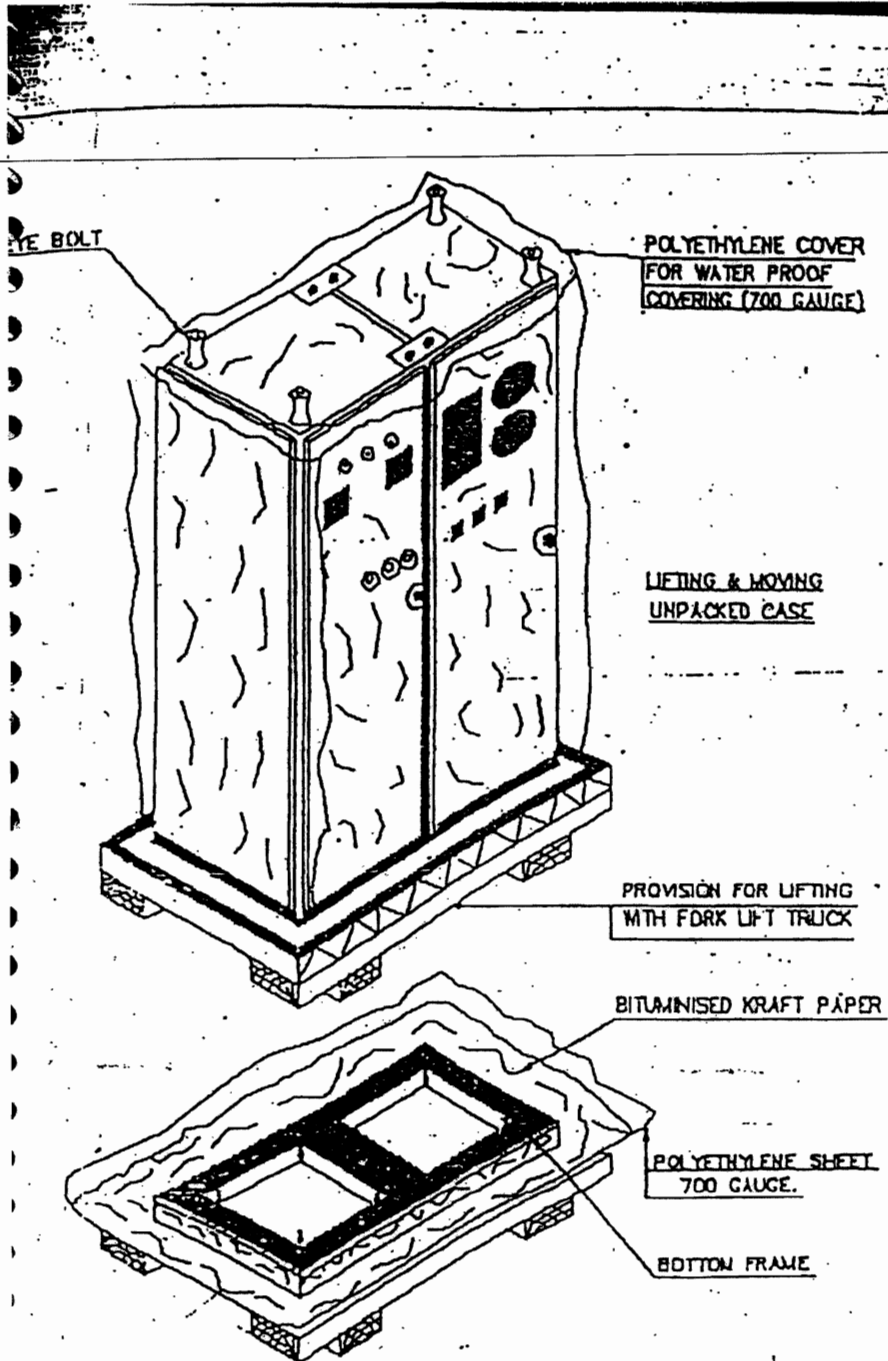



FIGURE-14

	TITLE	SPECIFICATION NO. PE-TS-888-100-A001		
	TECHNICAL SPECIFICATION FOR SEAWORTHY PACKING FOR EXPORT JOBS	VOLUME II B		
		SECTION D		
		REV. NO. 0	DATE 10/08/2010	
		SHEET 28	OF	52

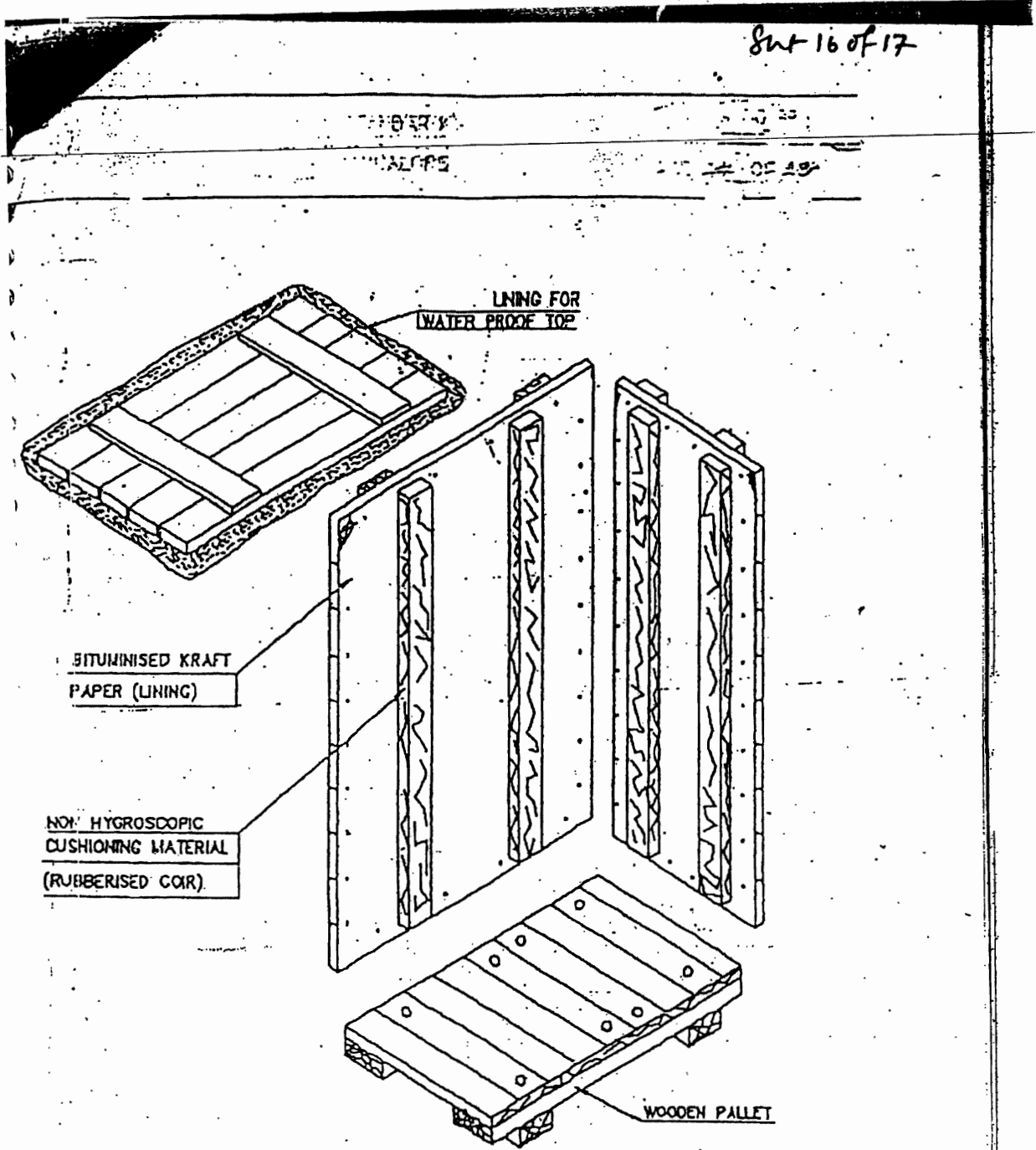



FIGURE-15

	TITLE	SPECIFICATION NO. PE-TS-888-100-A001	
	TECHNICAL SPECIFICATION FOR SEAWORTHY PACKING FOR EXPORT JOBS	VOLUME II B	
		SECTION D	
		REV. NO. 0	DATE 10/08/2010
		SHEET 29	OF 52

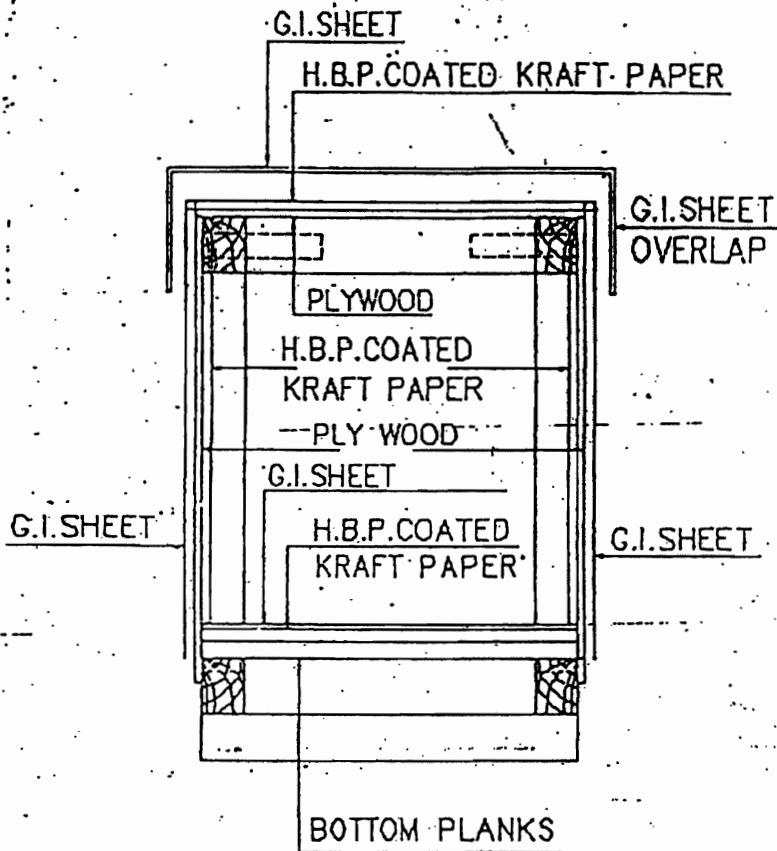



FIG-16 : CLOSED PACKING CASE WITH G.I.SHEET
SHOWING LAYERS OF PACKING MATERIALS.

	TITLE	SPECIFICATION NO. PE-TS-888-100-A001	
	TECHNICAL SPECIFICATION FOR SEAWORTHY PACKING FOR EXPORT JOBS	VOLUME II B	
		SECTION D	
		REV. NO. 0	DATE 10/08/2010
		SHEET 30	OF 52

10.0 TYPICAL PACKING DETAILS/PROCEDURE FOR MECHANICAL ITEMS

10.1 INSULATION MATERIAL (MINERAL WOOL MATTRESSES)

This specification covers the requirements of seaworthy packing and marking for bonded mineral (rock) wool mattresses having metallic hexagonal wire netting as facing on one or both sides.

10.1.1 TYPE OF CONSTRUCTION

Mattress shall be packed in Polythene (of 0.2 mm thickness) all around and sealed to prevent moisture absorption during transit and storage. Further it shall be wrapped with Bitumen coated Polythene bonded/lined Hessian and stitched and then packed in 5 ply DFC carton box.

Silica gel is used for this purpose to protect contents over sufficiently long time from corrosion. Silica gel shall be of indicating type conforming to IS:304-1979 packed in cotton bags placed at different positions inside the packing for absorbing moisture and shall not come into direct contact with the material inside the package. The quantity of silica gel shall be enough for storage period of one year. However, it shall not be less than 4 gms per litre volume of case subject to minimum of 400 gms per case.

Each mattress as well as the packages shall be serial numbered. Also, printed sheets indicating the nominal thickness, density and wire netting details (i.e. material and size) shall be placed below the wire netting.

Following details shall be legibly written on the packages. The details shall also be typed on a sheet of paper & kept in a sealed Polythene cover, inside the packages

- a) Project Name
- b) Purchase Order No.
- c) Sl. No. of package
- d) Size of mattress (Thickness x Length x Width)
- e) Density
- f) Wire netting material and size
- g) Weight of the package

10.2 INSULATION MATERIAL (ALUMINIUM COIL)

Heavy Gauge Aluminium Coil Packaging are done by Eye-to-Sky packaging or by Eye to eye packaging as per the proven practice being followed by manufacturer of Aluminium sheets.

10.2.1 Type of construction for Eye to Sky packaging

- a. Strapping of coil with polyester strap around circumference at one place.
- b. Putting paper I. D. Edge protector.
- c. Wrapping the coil with VCI stretch film after putting silica gel bags (4 nos.) Inside the coil.
- d. Wrapping the coil with HDPE film.
- e. Covering the coil including its build up & bore with masonite / particle board.
- f. Putting metallic I. D on coil.
- g. Putting O.D edge protector (paper) on coil.

	TITLE	SPECIFICATION NO. PE-TS-888-100-A001		
	TECHNICAL SPECIFICATION FOR SEAWORTHY PACKING FOR EXPORT JOBS	VOLUME II B		
		SECTION D		
		REV. NO. 0	DATE 10/08/2010	
		SHEET 31	OF	52

- h. Putting circumferential polyester strap (3 nos.) & eye polyester strap (4 nos.).
- i. After placing the coil on coil tilter ply wood (10mm thick) of suitable size along with wooden pallet is to be put at the bottom side of the coil.
- j. Coil is to be tilted to eye-to-sky position.
- k. Final strapping with metallic strap to unit coil and skid at 2 places with top cover of plywood.
- l. Fixing the coil with wooden blocks at 4 corners.
- m. Labeling 2 nos.(one metallic & one adhesivetype) For specification, net wt. & gross wt.

10.2.2 Type of construction for Eye to Eye packaging

- a. Strapping of coil with polyester strap around circumference at one place.
 - b. Putting paper I. D. Edge protector.
 - c. Wrapping the coil with VCI stretch film after putting silica gel bags (4 nos.) Inside the coil.
 - d. Wrapping the coil with HDPE film.
 - e. Covering the coil including its build up & bore with masonite / particle board.
 - f. Putting metallic I. D on coil.
 - g. Putting O.D edge protector (paper) on coil.
 - h. Putting circumferential polyester strap (3 nos.) & eye polyester strap (4 nos.).
 - i. Placing of coil on wooden skid Coil is to be tilted to eye-to-sky position.
 - j. Final strapping of coil and skid at 2 places with steel strap. Fixing the coil with wooden blocks at 4 corners.
- Labeling 2 nos.(one metallic & one adhesive type) For specification net wt. & gross wt.

10.3 Packing Procedure for Online Tube Cleaning System and accessories

This procedure is applicable for the shipment of Onload Tube Cleaning System and accessories by sea.

10.3.1 Packing details:

- The Packing case shall be made of treated rubber wood. The design of the case shall be as per Annexure IIIA & IIIB.
- The Equipments shall be placed on the wooden base of the Packing case and fastened if required to arrest the movement of the same.
- Equipment shall be covered by Polythene sheet and inside wall surfaces of the wooden cases also shall be covered by polythene sheet.
- All Nozzles shall be closed with plywood dummies.
- All electrical components assembled or loose shall be covered with polythene sheets along with silica gel pack.
- Silica gel desiccants shall be kept inside each case in sufficient quantities in order to absorb the moisture.

	TITLE	SPECIFICATION NO. PE-TS-888-100-A001	
	TECHNICAL SPECIFICATION FOR SEAWORTHY PACKING FOR EXPORT JOBS	VOLUME II B	
		SECTION D	
		REV. NO. 0	DATE 10/08/2010
		SHEET 32	OF 52

- Thermocol packing shall be made for glass items like Ball vessel sight glass, Vpiece sight glass & pressure gauge.
- Silica gel desiccants shall be kept inside of each case to absorb the moisture.
- A Packing list covered in a polythene envelope shall be fixed inside and outside of each packing case.
- Shipping marks and consignee address shall be painted on the outer surface of the case.
- All handling instruction required for the case like top, sling, rain, handle with care etc, shall be marked on the case as per the symbol attached.
- Machined surface will be applied with Anti rust oil and covered by polyurethane sheet to protect from external oxidation.
- All valves will be closed with dummies to protect the internals and placed in the wooden case which will covered by polyurethane sheet.

	TITLE	SPECIFICATION NO. PE-TS-888-100-A001	
	TECHNICAL SPECIFICATION FOR SEAWORTHY PACKING FOR EXPORT JOBS	VOLUME II B	
		SECTION D	
		REV. NO. 0	DATE 10/08/2010
		SHEET 33	OF 52

MODEL: FASTNERS TYPE (BASE, SIDE & TOP ATTACHED WITH BOLT, NUT & WASHER)

This Type of case to be used for following items:

1. BALL SEPERATOR
2. BALL COLECTOR SKID

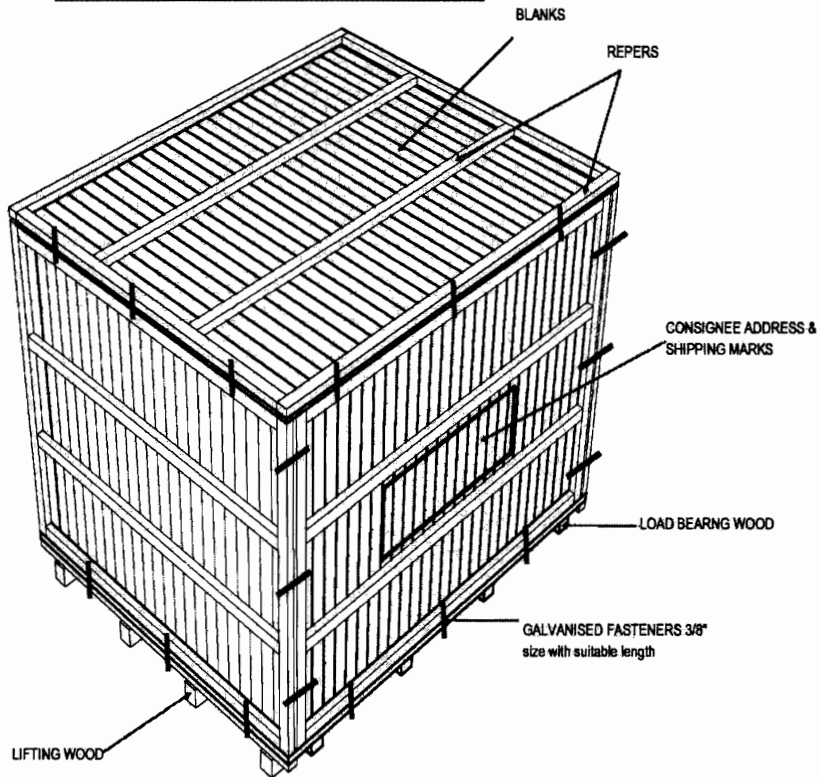

	TITLE	SPECIFICATION NO. PE-TS-888-100-A001		
	TECHNICAL SPECIFICATION FOR SEAWORTHY PACKING FOR EXPORT JOBS	VOLUME II B		
		SECTION D		
		REV. NO. 0	DATE 10/08/2010	
		SHEET 34	OF	52

BASE FRAME

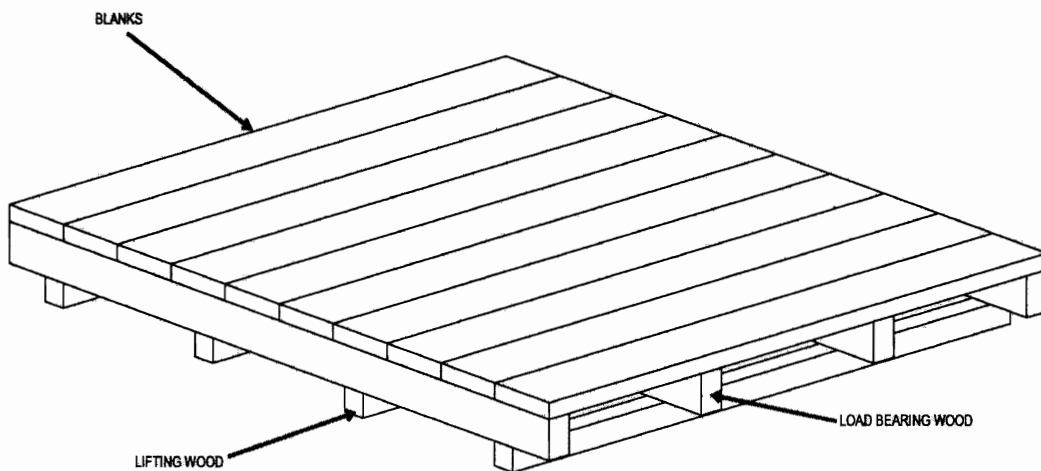

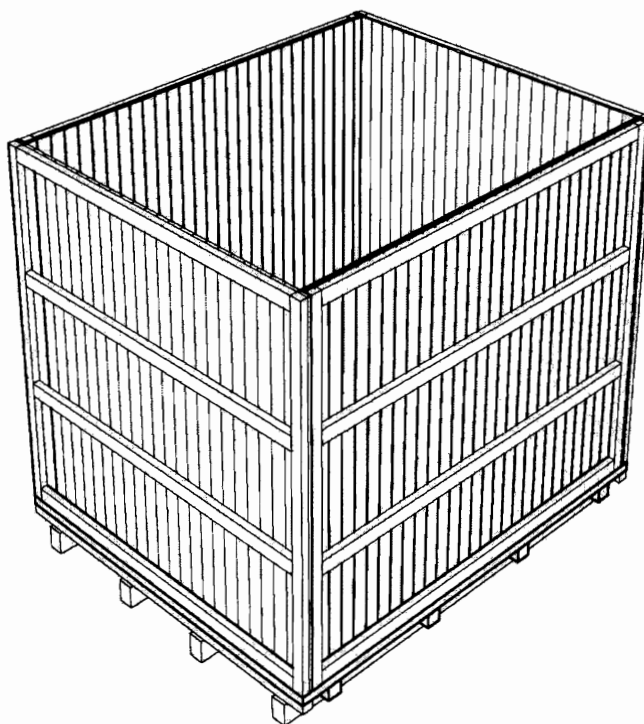

	TITLE TECHNICAL SPECIFICATION FOR SEAWORTHY PACKING FOR EXPORT JOBS	SPECIFICATION NO. PE-TS-888-100-A001	
		VOLUME II B	
		SECTION D	
		REV. NO. 0	DATE 10/08/2010
		SHEET 35	OF 52

MODEL: FASTNERS TYPE - WITHOUT TOP

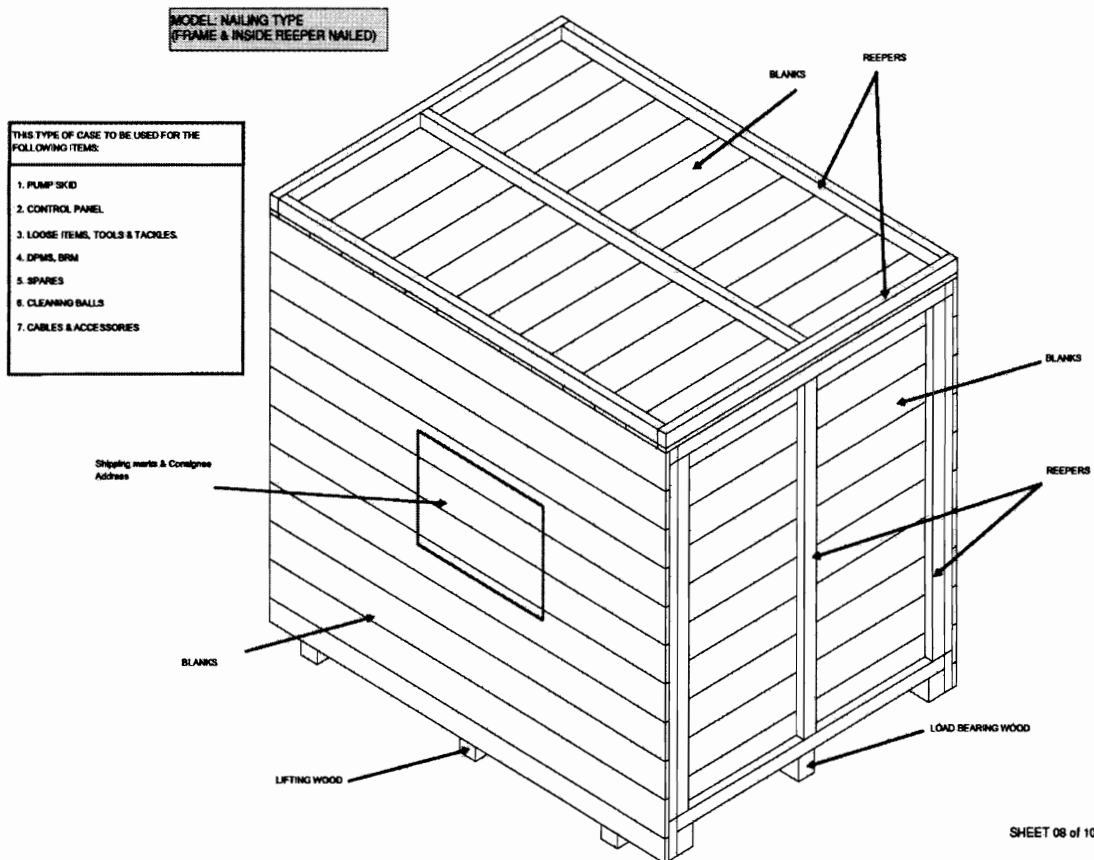

	TITLE	SPECIFICATION NO. PE-TS-888-100-A001	
	TECHNICAL SPECIFICATION FOR SEAWORTHY PACKING FOR EXPORT JOBS	VOLUME II B	
		SECTION D	
		REV. NO. 0	DATE 10/08/2010
		SHEET 36	OF 52



	TITLE	SPECIFICATION NO. PE-TS-888-100-A001	
	TECHNICAL SPECIFICATION FOR SEAWORTHY PACKING FOR EXPORT JOBS	VOLUME II B	
		SECTION D	
		REV. NO. 0	DATE 10/08/2010
		SHEET 37	OF 52

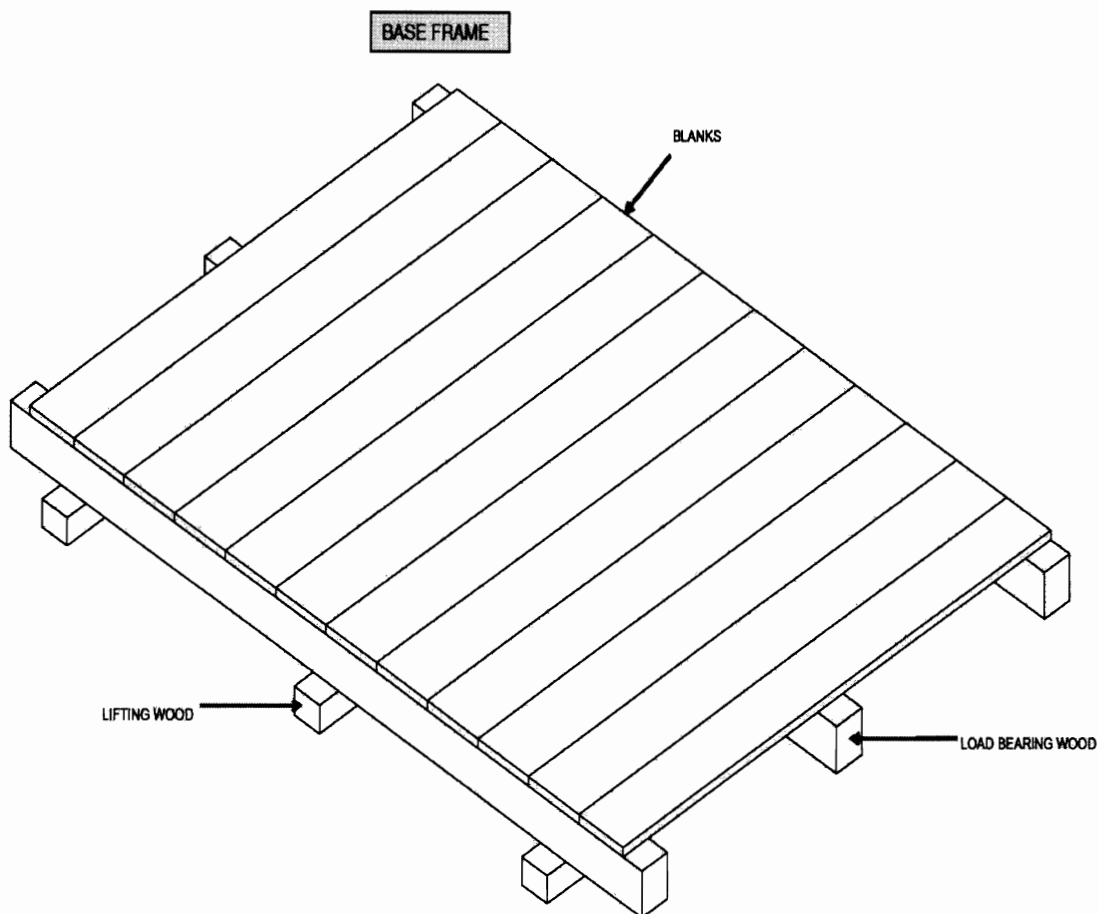

SHEET 09 of 10

	TITLE TECHNICAL SPECIFICATION FOR SEAWORTHY PACKING FOR EXPORT JOBS	SPECIFICATION NO. PE-TS-888-100-A001	
		VOLUME II B	
		SECTION D	
		REV. NO. 0	DATE 10/08/2010
		SHEET 38	OF 52

NAILING TYPE MODEL WITH TOP OPEN

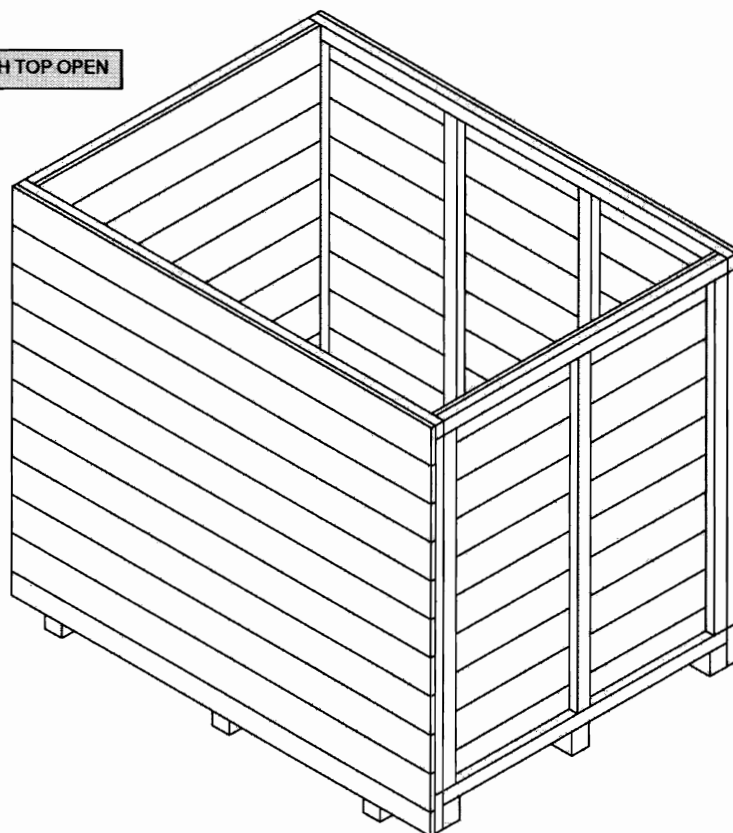

	TITLE	SPECIFICATION NO. PE-TS-888-100-A001	
	TECHNICAL SPECIFICATION FOR SEAWORTHY PACKING FOR EXPORT JOBS	VOLUME II B	
		SECTION D	
		REV. NO. 0	DATE 10/08/2010
		SHEET 39	OF 52

10.4 PACKING OF LOOSE ITEMS

Loose mechanical, electrical and C&I items e.g. valves, fittings, pressure/temperature gauges/switches, circuit breakers, relays etc shall be individually wrapped using polyethylene sheets/U foam/ thermocol sheets/air bubble sheets depending upon the items and then packed in wooden boxes. The left out spaces and top of the boxes shall be filled with rubberized coir to get proper cushioning effect, Special attention shall be paid to relays, instruments etc for arresting the movements of their operating mechanism during transportation.

The construction of wooden packing cases shall be as per clause 9.3.1 retaining its all features concerning strength of the box. The construction of wooden packing case for electrical and C&I items shall be as per fig-16.

Inner surface of 6 sides of the box shall be lined with bitumen coated hessian polyethylene kraft paper. Rubberized coir of min. 25mm thickness and 100 mm width shall be nailed to inner surfaces of bottom and 4 sides of the boxes.

11.0 PACKING OF ELECTRICAL ITEMS

11.1 CABLES

11.1.1 **Type of Equipment**
All type of cables..

11.1.2 **Type of Construction**

New or practically new cable drums made of steel and painted with epoxy resin paint are to be used. Cable ends are carefully protected before packing. Over the cables polyethylene sheet shall be wrapped and then sealed properly. Cable drum can be put in wooden crates for ease in transportation and handling. (Wooden cable drum is also acceptable, however vendor to furnish constructional details for approval).

	TITLE	SPECIFICATION NO. PE-TS-888-100-A001	
	TECHNICAL SPECIFICATION FOR SEAWORTHY PACKING FOR EXPORT JOBS	VOLUME II B	
		SECTION D	
		REV. NO. 0	DATE 10/08/2010
		SHEET 40	OF 52

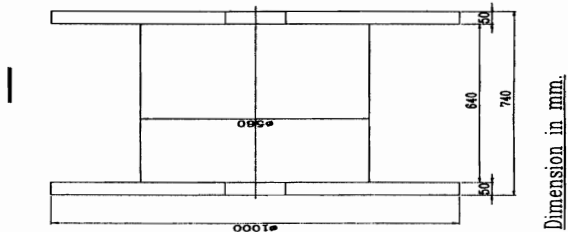
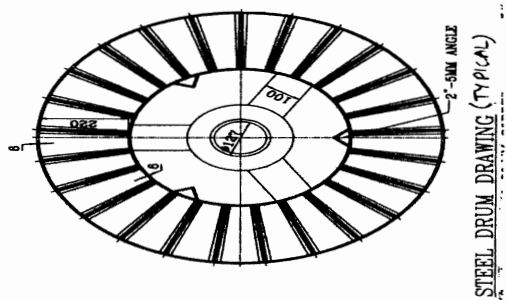

	TITLE TECHNICAL SPECIFICATION FOR SEAWORTHY PACKING FOR EXPORT JOBS	SPECIFICATION NO. PE-TS-888-100-A001	
		VOLUME II B	
		SECTION D	
		REV. NO. 0	DATE 10/08/2010
		SHEET 41	OF 52

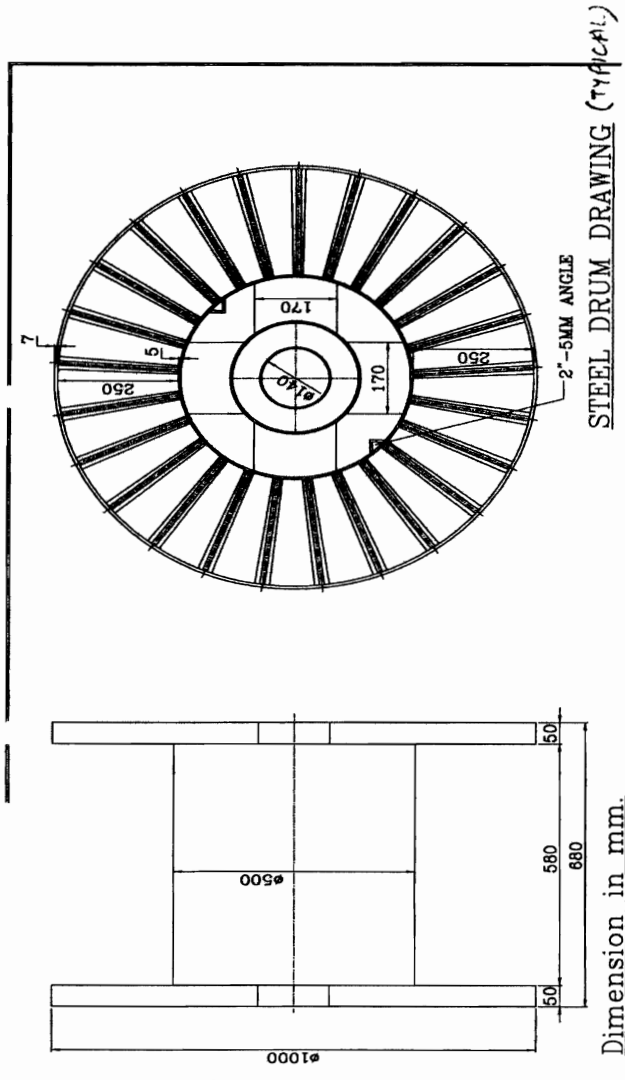

11.2 PACKING OF CABLE TRAYS & ACCESSORIES AND CABLE TRAY SUPPORT MATERIAL

11.2.1 Cable trays can be packed in wooden boxes as per fig 1 to 11 or in steel boxes. Details of steel box construction is as indicated below.

- 1) All Dimensions are in "mm" unless otherwise stated.
- 2) Packing Box shall be fabricated using 50x50x6mm MS Angle, 50x3mm Flat, 2.5 mm thick C Channel, 1mm & 1.6mm Thick sheet.
- 3) Finish of Packing Box Shall be Galvanized.
- 4) Angle & Channel Section forming part of the Main frame shall be welded thoroughly with each other to give a rigid structure.
- 5) Sheet Section and Flat section shall be bolted/ Riveted/ Welded suitably to the Main frame stated in '4' above.

	TITLE	SPECIFICATION NO. PE-TS-888-100-A001	
	TECHNICAL SPECIFICATION FOR SEAWORTHY PACKING FOR EXPORT JOBS	VOLUME II B	
		SECTION D	
		REV. NO. 0	DATE 10/08/2010
		SHEET 42	OF 52

- 6) Welding Portion on galvanized surfaces shall be painted with Zinc Rich Paint.
- 7) Dispatch details such as consignor/consignee address, contract and case details, 'country of origin, port of delivery, stacking instructions shall be written on one of the side of boxes. An anodized aluminium plate as per details and specifications given in page 3 of 5 shall be provided on the boxes
- 8) One copy of packing slip wrapped in polythylene bag covered with suitable aluminium .packing slip holder to be nailed on the external surface of the box. One more copy 9f the packing Slip wrapped in polythylene bag to be kept inside the box at the prominent place.
- 9) **INDICATION MARKS ON THE BOXES:** Markings shall be provided on the boxes indicating position of Boxes for handling, storage and nature of consignment. For guidelines referred page 4 of 5. The ink issued for this purpose as well as for marking dispatch instruction shall be indelible/non-washable marking ink.
- 10) Each item as mentioned in BOQ shall be packed & supplied as a set comprising of required numbers of associated fasteners & hardware etc

	TITLE	SPECIFICATION NO. PE-TS-888-100-A001	
	TECHNICAL SPECIFICATION FOR SEAWORTHY PACKING FOR EXPORT JOBS	VOLUME II B	
		SECTION D	
		REV. NO. 0	DATE 10/08/2010
		SHEET 43	OF 52

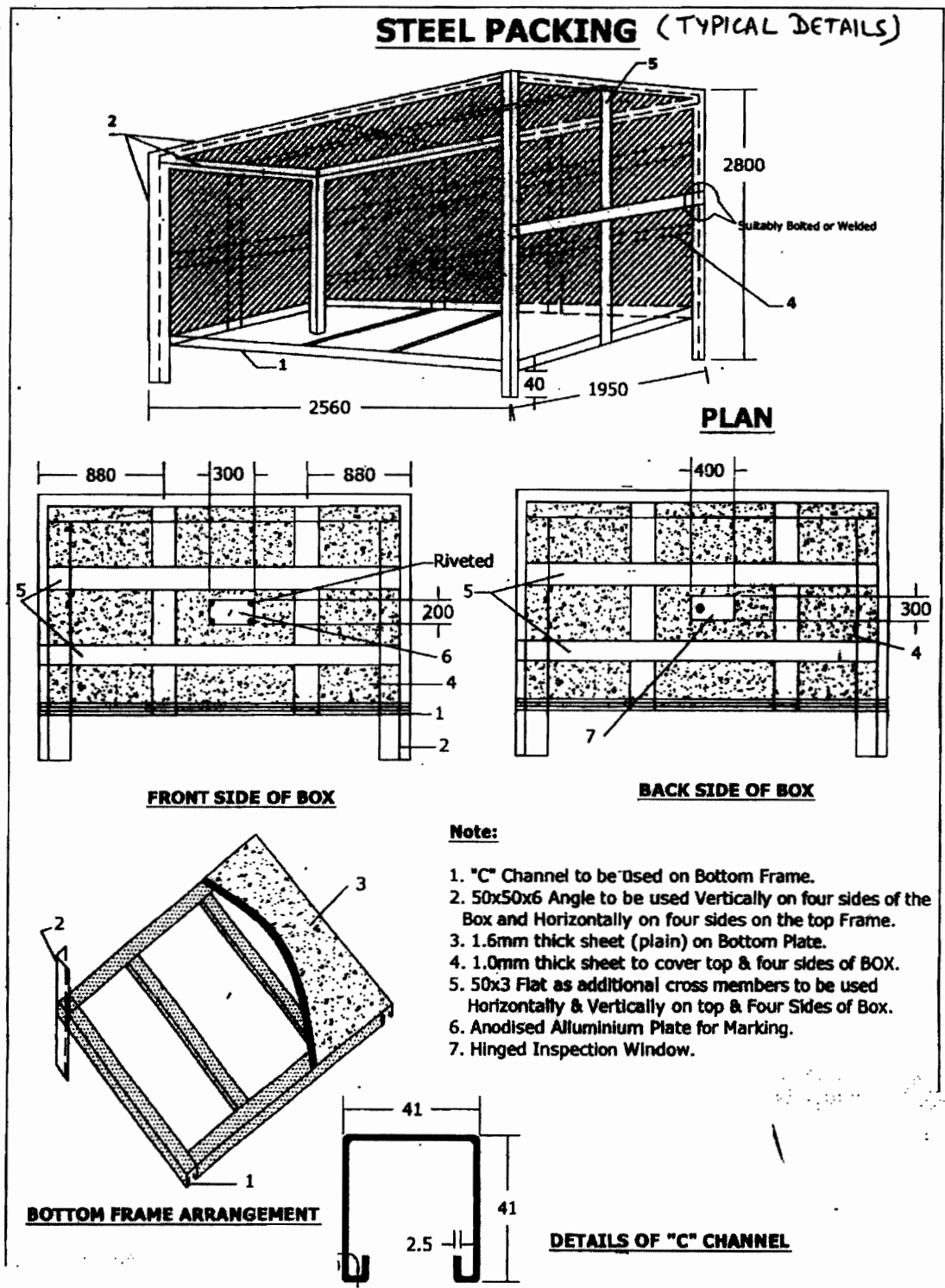

	TITLE	SPECIFICATION NO. PE-TS-888-100-A001	
	TECHNICAL SPECIFICATION FOR SEAWORTHY PACKING FOR EXPORT JOBS	VOLUME II B	
		SECTION D	
		REV. NO. 0	DATE 10/08/2010
		SHEET 44	OF 52

11.3 PACKING FOR STATION LIGHTING SYSTEM

Aspects of packing specific to equipments / items of station lighting system are given here. All other instructions / aspects as per the main specification of export packing which are not covered here shall also be applicable.

11.3.1 For LIGHTING TRANSFORMER, DISTRIBUTION BOARDS, LIGHTING PANELS,

- a) Construction of packing case for LIGHTING DISTRIBUTION BOARDS, LIGHTING PANELS, TRANSFORMER . shall be EITHER as per FIGURE 1,2,3,5,6,7,8,9,10,11 OR FIGURE 14,15,16.
- b) Each Panel/Transformer shall be individually covered with double polythene sheet of thickness 175 microns minimum.
- c) All the 6 inner surfaces of packing shall be nailed with bitumen coated hessian polythene craft paper. Wherever 2 pieces of craft paper are used, the joint shall have minimum overlap of 20mm.

For the top frame it shall be project on all sides by 100mm and shall be nailed on sides .

- d) The gap between the panels and packing case shall be filled with rubberized coir of thickness 50mm minimum and width 100mm. The distance between two consecutive supports of rubberized coir shall be less than 500mm.
- e) Silica get packed in cotton bags shall be placed at different positions inside the packing.
- f) Packing case shall be finally covered with GI sheet of thickness 0.4mm minimum.

11.3.2 For LUMINARIES, RECEPTACLES. EMERGENCY LIGHT, 240/24V TRANSFORMER, CEILING FAN, SWITCH BOARDS, FLEXIBLE CONDUIT, WIRES, EARTH WIRE. JUNCTION BOXES, ERECTION COMMISSIONING SPARES, RECOMMENDED SPARES , ERECTION MATERIAL AND CONSUMBALES

- a) Construction of packing case for THE ABOVE MATERIAL shall be as per FIGURE 1to11.
- b) Items placed inside the case shall be covered with double polythene sheet of thickness 175 microns minimum.
- c) All the 6 inner surfaces of packing shall be nailed with bitumen coated hessian craft paper. wherever 2 pieces of craft paper are used, the joint shall have minimum overlap of 20mm. For the top frame it shall be project on all sides by 100mm and shall be nailed on sides.
- d) Silica get packed in cotton bags shall be placed at different positions inside the packing.

11.3.3 For CONDUIT PIPE

As per international practice pipes are shipped in open bundles with metal strapping. Packing as per attached figure A shall be provided which is described as following:

- a) Each bundle shall be wrapped with 2 layers of 175 microns thick polythene sheet.
- b) Then bundle will be wrapped with bitumen coated hessian craft paper.
- c) Bundle shall be strapped with steel straps.
- d) An anodized aluminium packing description plate as per Figure No. 13 shall be provided.

11.3.4 For POLES

Poles will be wrapped with 2 layers of minimum 175 microns thick polythene sheet and then with bitumen coated hessian craft paper, packed as per Figure – C i.e. bundling.

11.3.5 For STRUCTURAL STEEL

	TITLE TECHNICAL SPECIFICATION FOR SEAWORTHY PACKING FOR EXPORT JOBS	SPECIFICATION NO. PE-TS-888-100-A001	
		VOLUME II B	
		SECTION D	
		REV. NO. 0	DATE 10/08/2010
		SHEET 45	OF 52

Structural steel will be different sizes and shapes. Hence it will be packed as per Figure No. B and described as following :

- a) Each bundle shall be wrapped with 2 layers of 175 microns thick polythene sheet.
- b) Then bundle will be wrapped with bitumen coated hessian craft paper.
- c) Bundle shall be strapped with steel straps.
- d) An anodized aluminium packing description plate as per Figure No. 13 shall be provided.

	TITLE	SPECIFICATION NO. PE-TS-888-100-A001	
	TECHNICAL SPECIFICATION FOR SEAWORTHY PACKING FOR EXPORT JOBS	VOLUME II B	
		SECTION D	
		REV. NO. 0	DATE 10/08/2010
		SHEET 46	OF 52

PACKING PROCEDURE FOR CONDUIT PIPE

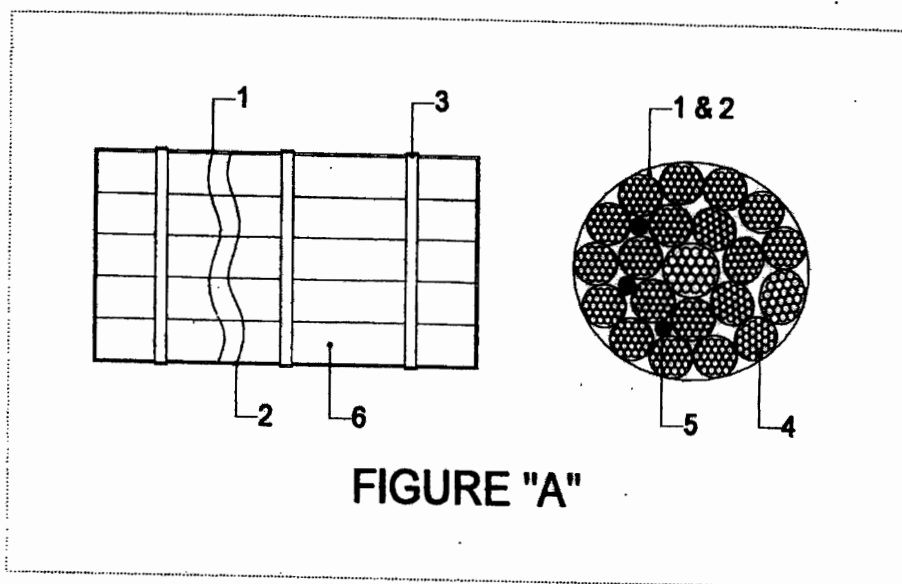

- 1) LAYER OF BITUMEN COATED HESSIAN KRAFT PAPER.
- 2) LAYER OF POLYTHENE SHEET.
- 3) METAL STRAPPING.
- 4) CONDUIT PIPES.
- 5) SILICA GEL POUCHES.
- 6) BUNDLES OF CONDUIT PIPES.

	TITLE	SPECIFICATION NO. PE-TS-888-100-A001	
	TECHNICAL SPECIFICATION FOR SEAWORTHY PACKING FOR EXPORT JOBS	VOLUME II B	
		SECTION D	
		REV. NO. 0	DATE 10/08/2010
		SHEET 47	OF 52

PACKING PROCEDURE FOR STRUCTURAL STEEL

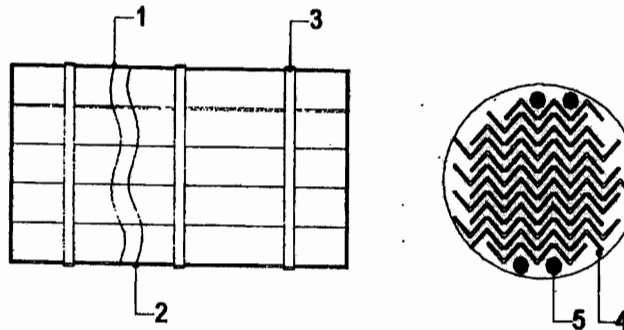

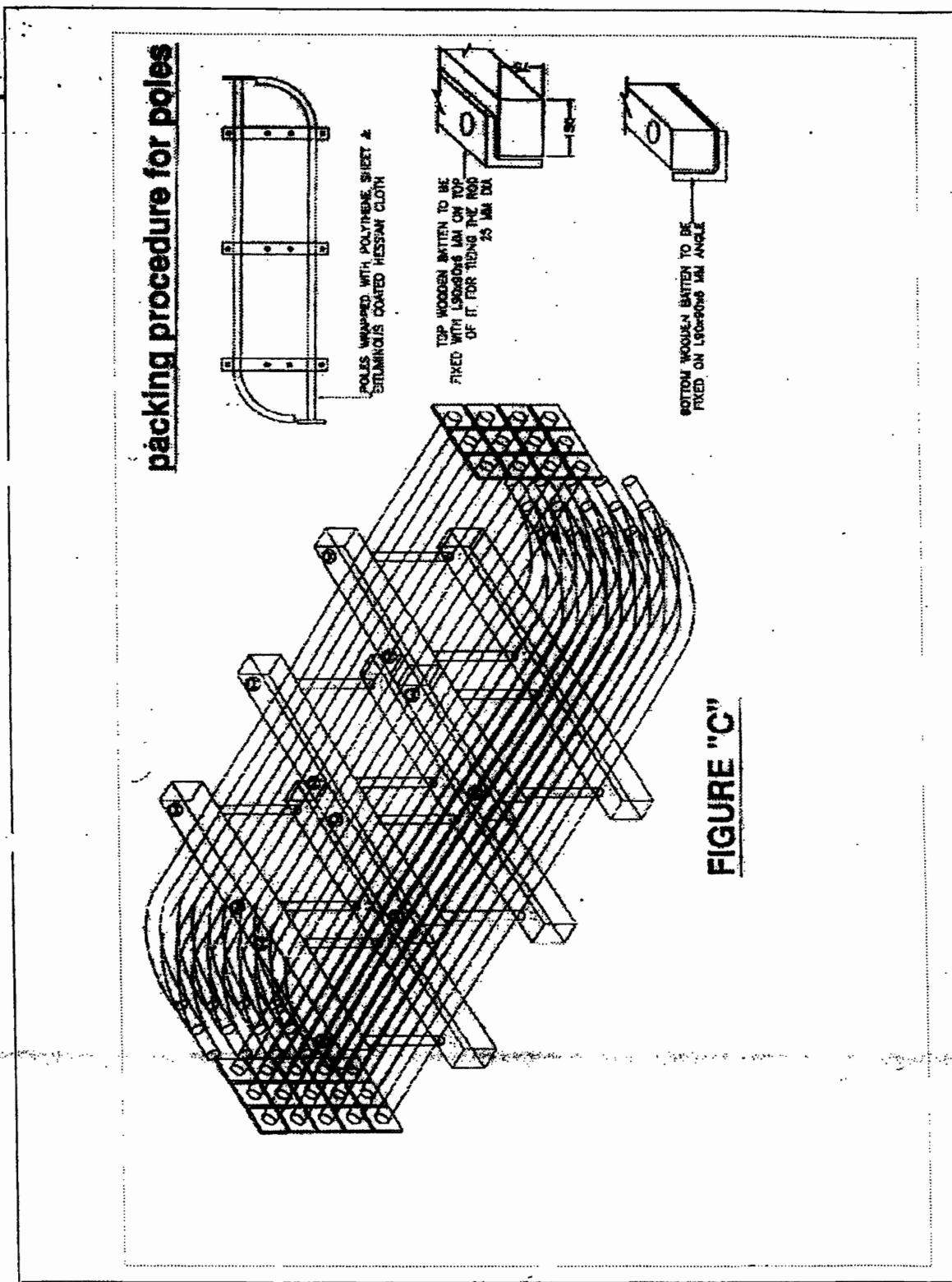



FIGURE "B"

- 1) LAYER OF BITUMEN COATED HESSIAN KRAFT PAPER.
- 2) LAYER OF POLYTHENE SHEET.
- 3) METAL STRAPPING.
- 4) STRUCTURAL STEEL.
- 5) SILICA GEL POUCHES.

	TITLE	SPECIFICATION NO. PE-TS-888-100-A001		
	TECHNICAL SPECIFICATION FOR SEAWORTHY PACKING FOR EXPORT JOBS	VOLUME II B		
		SECTION D		
		REV. NO. 0	DATE 10/08/2010	
		SHEET 48	OF	52



	TITLE	SPECIFICATION NO. PE-TS-888-100-A001	
	TECHNICAL SPECIFICATION FOR SEAWORTHY PACKING FOR EXPORT JOBS	VOLUME II B	
		SECTION D	
		REV. NO. 0	DATE 10/08/2010
		SHEET 49	OF 52

11.4 PACKING FOR DC BATTERY

The packing procedure for seaworthy packing of DC Battery is defined below, which is capable of withstanding impacts, compression, vibration, toppling, sea water spray, prevention against rust, temperature and extreme atmospheric conditions. Aspects of packing specific to equipments / items of DC Battery are given here. All other instructions / aspects as per the main specification of export packing which are not covered here shall also be applicable.

The packing procedure consists of various stages namely primary packing, cushioning, securing, desiccant, outside packing box, Runners/ sliders/ transverse bars of plywood, etc., provided for each movement.

- a) The packing boxes shall be made up of plywood boxes (thickness 9mm min.) with blocks at the bottom of the box for provision for handling the boxes using the forklift. The packing boxes sizes are generally standardized to half-euro size (capable of handling equipment's weight).
- b) Rubberized coir of 25mm thickness shall be provided as cushioning material at the bottom and thermocole of 20mm shall be provided inside on all four sides. Other than this polyethylene film wrap or cover also will be provided. Left out spaces to be filled with rubberized coir/ thermocol to get cushioning effect.
- c) Silica gel in dust free air permeable cotton/paper bag shall be placed in the packing boxes for storage period of 1 year as per IS 304 (1979)
- d) While packing the cells, transit caps (polypropylene) of red and blue shall be used for big size cells for ensuring that cells does not get damaged during the transport due to vibrations etc.
- e) The battery accessories shall be packed with suitable precautions as follows:
 - i) Copper connectors shall be packed after making bunches with lead wire seals to avoid misplacement.
 - ii) Hardware items shall be packed in polyethylene bags (Thickness ≥ 0.175 mm) with item slip
 - iii) Battery rack shall be packed in dismantled condition, wrapped with polyethylene sheet
 - iv) For Ni-Cd type battery, electrolyte in solid form for dry cells shall be packed in cans with KOH, LiOH being packed separately.
 - f) Galvanized Steel straps are provided for binding the packing box sides.
 - g) The handling instructions shall be marked in indelible/ non-washable ink, indicating the upright position.

11.5 PACKING OF SERVICE TRANSFORMERS(OIL FILLED) & ACCESSORIES

This instruction is applicable for packing of transformers (oil filled), its accessories and components so as to ensure safe delivery to end user. Aspects of packing specific to equipments / items of transformers(oil filled) are given here. All other instructions / aspects as per the main specification of export packing which are not covered here shall also be applicable.

11.5.01 PACKING DETAILS :

- a) Items shall be packed in case / crates as per the shipping list.
- b) All fragile items and small items shall be packed in cases and to be marked as "Fragile, handle with care Fragile items".
- c) Fragile accessories are to be first packed in their original boxes (VENDOR's packing). Very

	TITLE	SPECIFICATION NO. PE-TS-888-100-A001	
	TECHNICAL SPECIFICATION FOR SEAWORTHY PACKING FOR EXPORT JOBS	VOLUME II B	
		SECTION D	
		REV. NO. 0	DATE 10/08/2010
		SHEET 50	OF 52

- d small / delicate items such as glass thermometer, door keys shall be packed in separate box.
In case original box is found damaged, suitable alternate box or packing method using felt or foam sheet and polythene wrap to be used.
- e These boxes are then placed in identified wooden boxes. Inside of such boxes are lined with a layer of polythene sheet, packing wool / grass and another layer of polythene sheet before placing the boxes. All boxes are then wrapped with this polythene sheet before closing the box. Fragile items shall not be placed loose, one above the other inside the case.
- f All wiring cables, connection flats of non-ferrous materials, CTs, valves bellows shall also be packed.
- g Items like CTs, Oil communicating bushings, insulators, wired equipments and housings such as RTCC Panel, M. Box, Drive Mechanism, thermometers, gauges shall be wrapped in polythene from all around.
- h Buchholz relay and OSR relay openings will be blanked using covers, before putting them in the box
- i Items shall be carefully lowered and arranged inside the crate / case and each item shall be locked from all sides in such a way to avoid its movement in any way. Wooden stoppers and separators shall be provided for this and nailed to the crate / case wood.
- j Wooden planks and batons in contact with fragile items shall be provided with kit foam at the locations of contact.
- k Oil communication bushings shall be packed in separate case on V or U shape wooden felted supports, as in case of condenser bushings.
- l While placing and arranging the items inside the crates / cases, these shall be verified for correctness and then the packing note shall be signed. The cover top of the crate / case shall then be closed.
- m The main equipment like transformer tank shall be packed suitably to prevent any damage during transit / storage. Support structures like frame, header supports etc. shall be crated. Conservator headers shall also be crated. Radiators pipe work and other instruments & components shall be packed in cases. All the cases shall be lined with polythene from inside.

11.6 ALTERNATIVE PACKING CASES FOR CONTROL PANELS AND SWITCH GEARS

For Control and switch gear panels, construction of wooden packing cases may be provided as per fig 14 & 15 and as detailed below.

Thickness of planks for all sides, binding and jointing battens shall be at least 25 mm. Width of the plank shall be at least 125mm and that of binding and jointing planks shall be at least 100mm.

Top frame shall be suitable so that it does not collapse due to sandwiching between slings while lifting. Longitudinal and traverse bars for the bottom wooden pallet to be suitably selected.

Diagonal bracings shall be as per cl 9.3.1.3 and all other requirements shall be as per clauses 9.3.1.4 to 9.3.1.6.

12.0 Containerization

As required by BHEL, the VENDOR shall stuff the GOODS into 20 or 40 foot containers (dry, open top, flat racks, etc.).

The maximum inside dimensions of containers are to be considered:

	TITLE	SPECIFICATION NO. PE-TS-888-100-A001	
	TECHNICAL SPECIFICATION FOR SEAWORTHY PACKING FOR EXPORT JOBS	VOLUME II B	
		SECTION D	
		REV. NO. 0	DATE 10/08/2010
		SHEET 51	OF 52

- 40 foot containers: 11.80 m x 2.20 m x 2.05 m
- 20 foot containers: 5.80 m x 2.20 m x 2.05m
-

The present definition of containerization is valid for sea containers only. Vendor to check the size of containers before start of packing of equipment.

12.1 Protection of Cases/Crates

Since shipping containers are in general not water tight, packing in contact with the floor of the container shall be raised in order to prevent it from being damaged by the accumulation of water.

12.2 Mechanical Constraints

The mechanical constraints for "general use" closed containers are of a different nature (height of "stacking" being limited inside the containers), the packing for the GOODS may be of a lighter structure. However, it is necessary that the packing be appropriate so as to protect the GOODS on site during the storage period, as required after discharging of the GOOD'S from the containers.

Note:

It is the responsibility of the VENDOR to ensure that the cases/crates are stowed, secured and fastened inside the container. The VENDOR will take all necessary precautions to conform to the maximum weight allowed and the centre of gravity of the container. The securing and fastening of the cases/ crates can be carried out by nailing timbers on the bottom or on the vertical sides of the container.

13.0 Other Services to be provided by Vendor

In addition to the packing and shipping documents, VENDOR must also carry out the following services, which shall be included in his quotation:

Carriage of VENDOR's sub-contracted equipment and material, which must be re-grouped in VENDOR's or PACKER's workshops, whilst waiting for packaging.

BHEL reserves the right to postpone the shipping of the GOODS. In this event, any storage and insurance costs during the first ninety (90) days shall be borne by the VENDOR.

Loading, including lifting, securing, lashing, and stowing, of all cases, crates, or packages onto means of transportation such as, but not limited to, trailers, containers, etc.

14.0 Responsibilities and Guarantees

VENDOR is responsible for the choice of category for packing according to the transport facilities used, and on the basis of the present document. In case of doubt or disagreement regarding the choice, VENDOR must inform BHEL prior to packing and await BHEL's approval. All phases of packaging, marking, loading, etc. will be subject to BHEL inspection.

BHEL reserves the right to reject the packing when the packing does not conform to these instructions and/or when the packing does not ensure perfect protection of the GOODS. VENDOR is responsible for the weights and dimensions declared, and the marking of the packages.

The documents must be in strict conformity with the packing contents.

The packing specified in these "Packing, Marking and Shipping Instructions" is guaranteed for a twelve (12) months storage period after delivery on site.

VENDOR is responsible for providing storage recommendation adapted to the GOODS. According to this guarantee, VENDOR is held responsible in the event of goods becoming

	TITLE	SPECIFICATION NO. PE-TS-888-100-A001	
	TECHNICAL SPECIFICATION FOR SEAWORTHY PACKING FOR EXPORT JOBS	VOLUME II B	
		SECTION D	
		REV. NO. 0	DATE 10/08/2010
		SHEET 52	OF 52

useless, damaged or broken, as a result of poor packing and/or stowing, or due to corrosion, subsequent to insufficient or inadequate protection. All direct or indirect costs resulting thereof, will be back-charged to VENDOR.

ANNEXURE – I
LT MOTOR: PROJECT SPECIFIC DETAILS

INDENT NO: RFW21735

Customer No: R4W1

Altitude	34 Meter above MSL.
ENERGY EFFICIENT	IE3 mentioned in IS: 12615
SUPPLY	Supply: 415V + 10% & -10%, 3 Phase, 50 Hz +5% & -5%.
STARTING CURRENT	As per the limit mentioned in the relevant standard with IE-3 efficiency class
RATIO OF LOCKED ROTOR KVA TO KW	
i) 50KW to 110KW	11
ii) 110KW to 200KW	9
MIN. SPACING BETWEEN GLAND PLATE AND CENTER STUD(IN MM)	
upto 3KW	As per manufacturer's practice
above 3KW and upto 7KW	85
above 7KW and upto 13KW	115
above 13KW and upto 24KW	167
above 24KW and upto 37KW	196
above 37KW and upto 55KW	249
above 55kw and upto 90KW	277
above 90KW and upto 125KW	331
above 125KW and upto 200KW	385/203 (For Single core cables only)
PHASE TO PHASE/PHASE TO EARTH AIR CLEARANCE(IN MM) IN TERMINAL BOX	
upto 110	10
above 110kw and upto 150KW	12.5
above 150KW	19
ADDITIONAL DATA TO BE INCLUDED IN DATASHEET	
GRADE OF BALANCING OF MOTOR	
STANDARD CONTINUOUS RATING AT 40DEG.C AMBIENT	
DERATED RATING OF MOTOR AT 50DEG.C(DESIGN POINT)	
NO LOAD CURRENT OF MOTOR AT RATED VOLTAGE AND FREQUENCY	
STARTING TORQUE VALUE IN KGM	
LOCKED ROTOR KVA @ RATED KW	
POWER FACTOR AND EFFICIENCY AT 75% LOAD	
POWER FACTOR AND EFFICIENCY AT 50% LOAD	
SPACE HEATER TERMINAL	Separate terminal box shall be provided
PAINTING	Will be intimated after PO

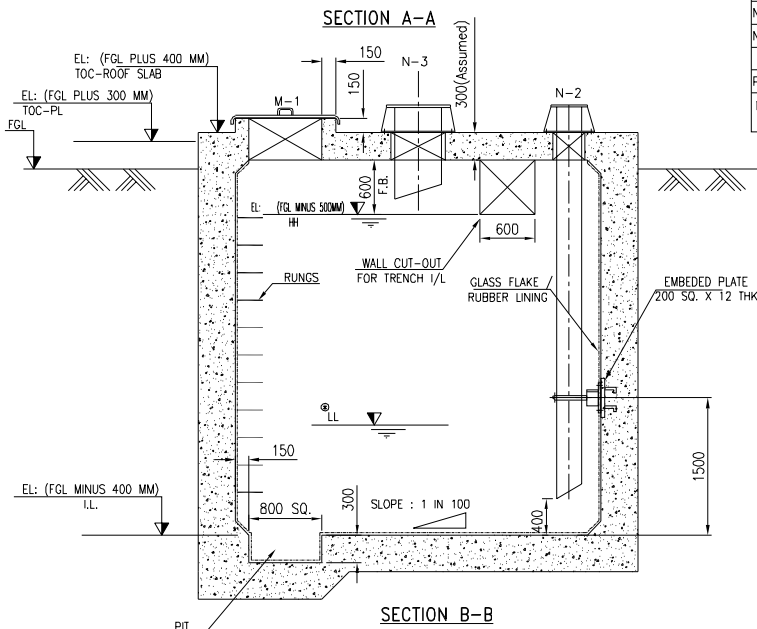
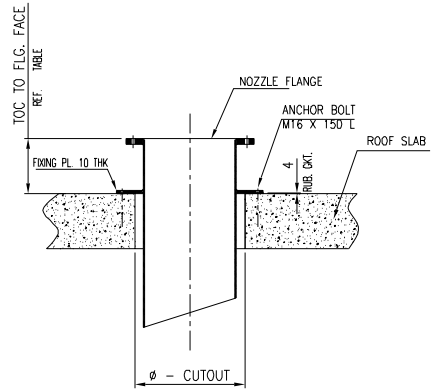
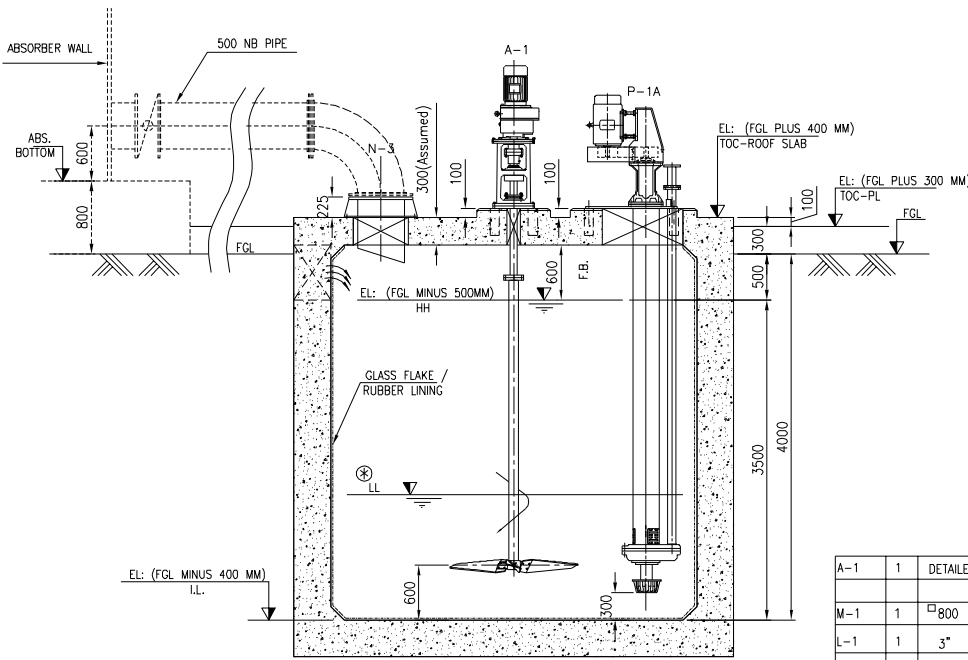
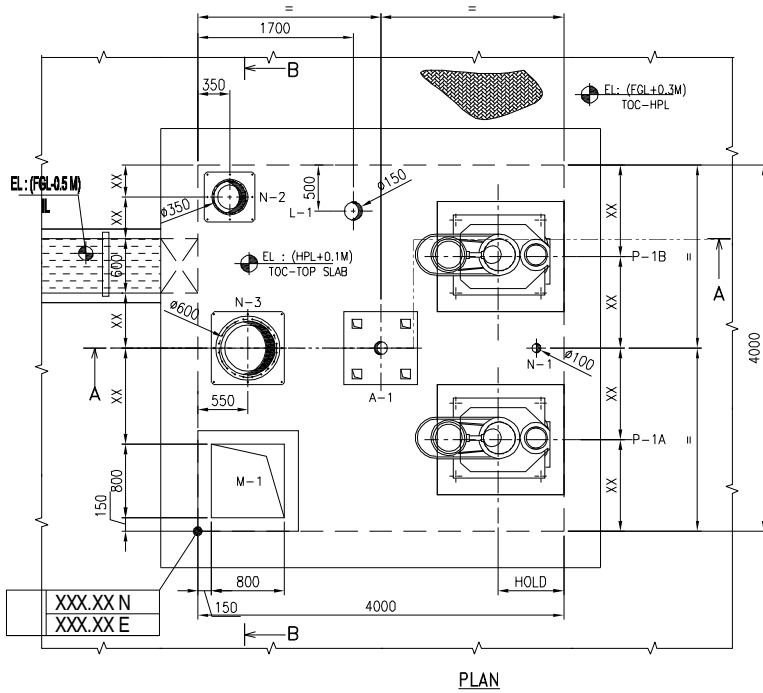

MARK	Nos.	SIZE	RATING	FACING	SERVICE	TOC TO FLG. FACE	SLAB CUTOUT SIZE	REMARKS
A-1	1	DETAILED	---	---	AGITATOR CONN.	---	DETAILED	
M-1	1	800	---	---	MANHOLE	---	800	WITH COVER
L-1	1	3"	ASME 150 ^{LB} S0	FF	LEVEL TRANSMITTER	200	Ø150	
N-3	1	20"	ASME 150 ^{LB} S0	FF	LIQUID INLET(ABS. DRAIN)	225	Ø600	
N-2	1	10"	ASME 150 ^{LB} S0	FF	LIQUID INLET(OVER FLOW)	200	Ø350	EXTENDED INSIDE
N-1	1	2"	ASME 150 ^{LB} S0	FF	PUMP DRAIN	200	Ø100	
P-1 A/B	2	DETAILED	---	---	PUMP	---	DETAILED	

NOTES :

1. ALL DIMENSION ARE IN MILLIMETER AND ELEVATION ARE IN METER.
2. SUITABLE DYNAMIC LOAD SHALL BE CONSIDERED FOR ROTARY EQPT . FDN. DESIGN.
3. SUMP BOTTOM FLOOR SLOPE SHALL BE MAINTAINED TOWARDS PIT.
4. SUMP INSIDE SURFACE SHALL BE GLASS FLAKE LINED.
5. DIMENSION MARKED WITH 'xx' SHALL BE FURNISHED INLINE WITH LAYOUT, PUMP CAD REQUIREMENT.
6. LL LEVEL SHALL FIXED BY BOI GROUP (BASED ON AGITATOR / PUMP REQUIREMENT)
7. A-1(AGITATOR SLAB CUTOUT) AND P-1 A/B(PUMP SLAB CUTOUT) WILL BE BASED ON VENDOR DETAILS TO BE OBTAINED FROM BOI GROUP.
8. M-1, L-1, N-2, N-1 WILL BE STANDARD CUTOUTS AS PER THE SIZES MENTIONED ABOVE.
9. N-3(ABS. DRAIN CUTOUT) TO BE TAKEN BASED ON THE ABS. DRAIN PIPE SIZE IN ABS. P&ID FROM PROCESS GROUP.

LEGEND :

- FGL - FINISHED GRAZED LEVEL
- FFL - FINISHED FLOOR LEVEL
- PL - PAVED LEVEL
- L - INVERT LEVEL
- STURDY BRN CONCRETE
- FINI DOWL

GENERAL ARRANGEMENT DRAWING OF ABSORBER AREA DRAIN SUMP

