

TECHNICAL PRE QUALIFICATION REQUIREMENT

Name of Project	2X660MW UDANGUDI STPP (STAGE-1)
Name of Customer	TAMILNADU GENERATION & DISTRIBUTION CORPORATION LTD. (TANGEDCO)
Name of Consultant	TATA CONSULTING ENGINEERS LIMITED BENGALURU
Name of Package	NITROGEN INJECTION FIRE PROTECTION SYSTEM

TECHNICAL PRE QUALIFICATION REQUIREMENT

- The bidder should have designed, supplied, erected, tested and commissioned at least One (1) number of Nitrogen Injection Fire Protection System for 220kV or above class Reactors/Transformers in installations such as power plants, sub-stations, electricity boards, transmission utility, refineries, fertilizer plant or other industrial installations.

This system should have been **#successfully commissioned as on date of original scheduled bid opening date of this tender.**

(#) Successfully commissioned means certificate issued by the Customer/ end user certifying the satisfactory operation without any adverse remark.

SUPPORTING DOCUMENTS TO BE ATTACHED

Sr	Required Criteria	Supporting Documents to be submitted by bidder along with technical bid
1	Design	Approved drawings/GTP etc.
2	Supply	Copy of PO/Work order/Material receipt certificate at site, etc.
3	Commissioning/ETC/ Execution	Pre commissioning report / commissioning report and final work completion or handing over report/certificate for complete system.
4	Successful Commissioning	Certificate/ Letter/ MOM from customer/end user for satisfactory/successful commissioning of NIFPS for the same projects for which POWO are being submitted.

Notes (General points):

- Consideration of offer shall be subject to customer's approval of bidder as approved vendor for this package.
- Bidder to submit all supporting documents in Hindi/English. If documents submitted by bidder are in language other than Hindi/English, a self- attested English translated document should also be submitted.
- Notwithstanding anything stated above, BHEL reserves the right to assess the capabilities and capacity of the bidder to perform the contract, should the circumstances warrant such assessment in the overall interest of BHEL.
- After satisfactory fulfilment of all the above criteria / requirement, offer shall be considered for further evaluation as per NIT and all the other terms of the tender.

Ayushi
Jindal

Digitally signed by Ayushi Jindal
DN: cn=Ayushi Jindal, o=BHEL,
ou=TBG, email=ayushi@bhel.in,
c=IN
Date: 2022.05.26 14:00:03 +05'30'

Prepared By:
Ayushi Jindal
Sr. Engineer (TBEM)

Asif Rizvi
31/5/22

Reviewed By:
Asif Rizvi
Manager (TBEM)

Vivek Kapil
31-5-22

Approved By:
Vivek Kapil
AGM (TBEM)

864340/2022/TBG-TB_ENG_SR



BHARAT HEAVY ELECTRICALS LIMITED

TRANSMISSION BUSINESS ENGINEERING MANAGEMENT

COPYRIGHT AND CONFIDENTIALITY The information on this document is the property of BHARAT HEAVY ELECTRICALS LTD. It must not be used directly or indirectly in anyway detrimental to the interest of the company	DOCUMENT No.	TB-400-552-126	Rev. No.	00	Prepared	Checked	Approved	
	TYPE OF DOC.	TECHNICAL SPECIFICATION			SIGN			
	TITLE	NITROGEN INJECTION FIRE PROTECTION SYSTEM			NAME	AJ	AR	AR
					DATE	23.05.22	23.05.22	23.05.22
					GROUP	TBEM	W.O. No	87005A UDG
	CUSTOMER	TAMILNADU GENERATION & DISTRIBUTION CORPORATION LTD.						
	CONSULTANT	TATA CONSULTING ENGINEERS LIMITED BENGALURU						
	PROJECT	2X660MW UDANGUDI STPP (STATE-1)						
	CONTENTS							
	Section	Description						Pages
1	Intent, Design criteria, System Requirement and scope						09	
2	Equipment Specification						05	
3	Project Details and General Technical Requirements						17	
4	Guaranteed Technical Particulars and List of Drawings						05	
5	Schedules to be filled by bidder and Enclosures to Specification						14	
REVISION DETAILS								
Rev No.	Date	Altered	Checked	Approved				
Distribution				To	TBEM	TBMM	TBQM	Vendor
				Copies				

	CLIENT – TAMILNADU GENERATION & DISTRIBUTION CORPORATION LTD.	TB-400-552-126
	CONSULTANT- TATA CONSULTING ENGINEERS LIMITED BEGALURU	Rev. 00
	PROJECT: 2X660MW UDANGUDI STPP – (STAGE-1)	Page 1
TECHNICAL SPECIFICATION FOR NITROGEN INJECTION FIRE PROTECTION SYSTEM		

SECTION 1 INTENT, SYSTEM REQUIREMENT, DESIGN CRITERIA AND SCOPE

1.1 SCOPE

- 1.1.1 This specification covers the Design, Engineering, manufacture, inspection and testing at Contractor's and/ or his Subcontractor's works, transportation & delivery (FOR destination), unloading, storage, handling, erection, testing & commissioning at site of **Nitrogen Injection Fire Protection System [NIFPS] for 125 MVAR Reactors of 3-phase, 420kV at Udangudi Site** as mentioned in different sections of this specification.
- 1.1.2 The Nitrogen Injection Fire Protection System shall be designed, erected & commissioned in accordance with Standards and regulations as mentioned in SECTION 2 of this Specification.
- 1.1.3 The requirement(s) specified under 'SECTION 2, SECTION 3, SECTION 4' and 'SECTION 5' of this specification shall be considered as part of this Specification. ***In case of any ambiguity / dispute between various sections, requirements of Section-1 shall prevail.*** In case of any other ambiguity between various Sections, the same shall be spelt out clearly and Clause wise in the Technical Deviation Sheet.
- 1.1.4 It shall be the responsibility of successful bidder to obtain necessary approval(s) /clearance(s) from statutory organization(s) / authority(s) wherever applicable for the equipment / system / sub-system(s) under the scope specified herein.
- 1.1.5 The Contract shall be on Unit Rate basis for the quantities furnished by BHEL. The quantities furnished in Price bid (BOQ) are as per preliminary design only. BHEL reserves the right for quantity variation (upward/ downward) due to any reason upto $\pm 30\%$ of total contract value at same unit rate and terms & conditions during execution of contract.
- 1.1.6 It is not the intent to specify herein all the details of design and manufacture. However, the equipment shall conform in all respects to high standards of design, engineering and workmanship and shall be capable of performing the required duties in a manner acceptable to Purchaser / Owner, who will interpret the meaning of drawings and specifications and shall be entitled to reject any work or material, which in his judgment is not in full accordance herewith.
- 1.1.7 The bidder shall be deemed to have understood completely all the tender drawings and documents and quoted accordingly.
- 1.1.8 The bidder has to note carefully the parameters, estimated capacities of equipment indicated and the tender drawing in the specification are only for guidance of the bidder. The system shall be designed as per relevant standards / codes and exact capacities and quantities are to be estimated by the bidder. All such estimations and design calculations shall be submitted for Purchaser's approval.
- 1.1.9 **Deviation:** Any deviation or variation from the Scope requirement and/or intent of this specification shall be clearly defined clause wise with respect to the specification under relevant **Deviation Schedule** given as schedule-1 in Section-5 of this specification. *Deviations in any other form including clarifications / assumptions / etc will not be considered and it will be construed that the bid conforms strictly to the specification.*
- 1.1.10 The specification comprises of following sections:
- Section -1: Scope, Technical requirements
 - Section - 2: Equipment Specification
 - Section - 3: Project Details & General Specifications
 - Section - 4: Guaranteed Technical Particulars and List of Drawings
 - Section - 5: Enclosures to Specification.

The equipment is required for the following projects:

	CLIENT – TAMILNADU GENERATION & DISTRIBUTION CORPORATION LTD.	TB-400-552-126
	CONSULTANT- TATA CONSULTING ENGINEERS LIMITED BEGALURU	Rev. 00
	PROJECT: 2X660MW UDANGUDI STPP – (STAGE-1)	Page 2
TECHNICAL SPECIFICATION FOR NITROGEN INJECTION FIRE PROTECTION SYSTEM		

Name of the Customer: **TAMILNADU GENERATION AND DISTRIBUTION CORPORATION LTD (TANGEDCO)**

Name of the Consultant: **TATA CONSULTING ENGINEERS LIMITED BENGALURU**

Name of the Project: **2X660 MW UDANGUDI STPP (STAGE-1)**

1.1.11 The term 'Customer' or 'Owner' appearing in this specification shall refer to **TANGEDCO**, the term 'Purchaser' shall refer to **BHEL** and the term 'Contractor' shall refer to the **Successful Bidder**.

1.2 TECHNICAL REQUIREMENTS

As per Equipment Specification mentioned in Section-2.

1.3 LIST OF NITROGEN INJECTION FIRE PROTECTION SYSTEM REQUIREMENT

Sl. No.	Description of Reactor on which Nitrogen Injection Fire Protection System is to be fitted	Unit	Quantity
1.	125 MVAr 420kV, 3-Ph ONAN Shunt Reactor (BHEL Make)	No.	02

1.4 TYPE OF FIRE PROTECTION REQUIRED

Complete independent Nitrogen Injection Fire Protection System for each of 2 Nos. 125 MVAr 3 Phase 420 kV Reactors BHEL make.

Sl. No.	Description	Make	Oil Quantity (Approx.) in each Rector
01	125 MVAr 420kV, 3-Ph ONAN Shunt Reactor	BHEL	60 kL

1.5 DESIGN CRITERIA

The **NITROGEN INJECTION FIRE PROTECTION SYSTEM** shall prevent tank explosion and fire during internal faults resulting in an arc where tank explosion will normally take 3-4 seconds after arc generation and also extinguishes the external oil fires on Reactor's top cover due to Tank explosion and/or external failures like bushing fires, OLTC fires and fires from surrounding equipments.

The **NITROGEN INJECTION FIRE PROTECTION SYSTEM** shall protect the oil filled Reactor against explosion fire that may emanate internally (during internal fault etc.) and / or externally (such as failure of condenser bushing of the Reactor under subject, other source of equipment etc.). It should be fully automatic and shall require minimum maintenance and practically no running cost.

All the requirements regarding supplies, provisions of control, interlocks, indications, annunciators, alarms etc., stipulated in Specification shall be satisfied by the contractor in totality.

1.6 SCOPE OF SUPPLIES & SERVICES

Exact requirements shall be worked out during detailed engineering after award of contract. The scope of the work under the contract shall be deemed to include all such items, which although not specifically mentioned in the bid documents and/or in the bidder's proposal, but are required to make the equipment/system complete for its safe, efficient, reliable and trouble free operation, unless the same is specifically excluded from the Bidder's scope of work under.

1.6.1 Scope of supply

Each set of NIFPS for reactor shall consist of mainly following items:

1. Supply and Installation of Fire Extinguishing Cabinet with base frame.



CLIENT – TAMILNADU GENERATION & DISTRIBUTION CORPORATION LTD.

TB-400-552-126

CONSULTANT- TATA CONSULTING ENGINEERS LIMITED BEGALURU

Rev. 00

PROJECT: 2X660MW UDANGUDI STPP – (STAGE-1)

Page | 3

TECHNICAL SPECIFICATION FOR NITROGEN INJECTION FIRE PROTECTION SYSTEM

2. Supply and Installation of Control box to be installed in control room on the cable trench with necessary mounting and fixing arrangement on the frame (back to back two tier type to suit site condition) as per Customer Specification and Approved Drawings.
3. Supply and Installation of Signal box as per Customer Specification and Approved Drawings.
4. Supply and Installation of Pre-stressed non-return valve (PNRV)/ high speed pneumatically operated ball valve (POBV) as per Customer Specification and Approved Drawings.
5. Supply and Installation of Fire detectors as per Equipment Specification and Approved Drawings including necessary Cabling arrangement for Fire Detector with FS Cable of suitable size, cable trays and any other items required for its mounting.
6. Supply and laying of FRLS cable of size 12C X 1.5 mm² in existing trenches along with Cable Trays of necessary sizes for connecting signal box mounted on Reactor to Control Box in the station control room, Relay Panel to Control Box and Control Box to FE Cubicle as per Customer Specification and Approved Drawings. Quantity of cable should be considered as per outdoor trench layout drawing furnished in this specification.
7. Supply and laying of FRLS cable of size 4C X 1.5 mm² in existing trenches along with Cable Trays of necessary sizes as per Customer Specification and Approved Drawings. Quantity of cable should be considered as per outdoor trench layout drawing furnished in this specification.
8. Supply and Installation of Oil drainpipe of suitable size for connection between outlet valves provided on Reactor tank and flange provided on top of FE cubicle as per specification and approved Drawings.
9. Supply and Installation of Oil drainpipe of suitable size for connection between oil drain pipe bottom (in FE cubicle) to the common oil pit for reactors as per approved drawings during detailed engineering. All the pipe and physical connection from reactor to oil pit shall be in the scope of contractor.

10. Painting system and procedures

The typical painting details for control cabinet/ marshalling box etc. shall be as given in **Annexure –F**. The proposed paint system shall generally be similar or better than this. The quality of paint should be such that its colour does not fade during drying process and shall be able to withstand temperature up to 120 deg C. The detailed painting procedure shall be finalized during award of the contract.

Annexure-F

Painting	Surface preparation	Primer coat	Intermediate undercoat	Finish coat	Total dry Film thickness (DFT)	Colour shade
Main tank, pipes, conservator tank, oil storage tank & DM Box etc. (external surfaces)	Shot Blast cleaning Sa 2½*	Epoxy base Zinc primer (30-40µm)	Epoxy high build Micaceous iron oxide (HB MIO) (75µm)	Aliphatic Polyurethane (PU) (Minimum 50µm)	Minimum 155µm	RAL 7035
Main tank, pipes (above 80 NB), conservator tank, oil storage tank & DM Box etc. Internal surfaces)	Shot Blast cleaning Sa 2½*	Hot oil proof, low viscosity varnish or Hot oil resistant, non-corrosive Paint			Minimum 30µm	Glossy white for paint

11. Supply and Installation of Nitrogen injection pipe of suitable size for connection between inlet openings on Reactor tank and flange provided on top of FE cubicle as per Customer Specification and Approved Drawings.

	CLIENT – TAMILNADU GENERATION & DISTRIBUTION CORPORATION LTD.	TB-400-552-126
	CONSULTANT- TATA CONSULTING ENGINEERS LIMITED BEGALURU	Rev. 00
	PROJECT: 2X660MW UDANGUDI STPP – (STAGE-1)	Page 4
TECHNICAL SPECIFICATION FOR NITROGEN INJECTION FIRE PROTECTION SYSTEM		

12. Supply and Installation of pipe of suitable size for support to oil drain as per Customer Specification and Approved Drawings.

- The Bidder shall quote as per special instructions, General and Special Conditions of Contract, Technical Specifications, and Drawings.
- The whole cost of complying with the provisions of the Contract shall be included in the quoted prices by bidders in the price schedule.
- Miscellaneous items like hardware, fixtures etc. shall be deemed to be included in the quoted prices.

13. LIST OF MANDATORY SPARES

The following mandatory spares may be supplied under one Set:

- 1 No.** filled nitrogen cylinder of each capacity/size for reactor
- 1 Set** of hose pipes with fittings of each capacity/size for reactor
- 2 Nos.** complete fire detectors alongwith sensors and other accessories

Bidder shall note the following:

- BHEL shall provide two feeders of 16 Amp 220V DC, each for control boxes in station control room. Bidder shall terminate this feeder in his control box and make his own arrangements to extend this supply elsewhere, if required, for monitoring system operation, automatic controls and remote operations. Control box should be complete with DC-DC converter for audio-visual alarm, indicating lights, switches, push buttons etc. suitable for tripping and signalling on 220V DC supply. The control box is to be installed in the switchyard control building based on control room lay out and feasibility. Necessary cables, cable laying, marshalling cabinets in control room, cabinets for fixation of control boxes etc. are under the scope of Bidder.
- FE Cubicle shall comprise of Fire Extinguishing Cabinet with base frame, consisting of:
 - Nitrogen Gas cylinder of sufficient capacity with pressure regulator and manometer with sufficient number of adjustable NO contacts.
 - Oil Drain Assembly
 - Mechanical release device for oil drain and nitrogen release.
 - Limit switches for monitoring the systems
 - Panel lighting
 - Flanges on top of the panel for connecting oil drain and nitrogen injection pipes for Reactor.
 - Oil drain pipe extension of suitable size for connecting pipes to oil pit.
 - Limit switch for pressure switch/ sensor.
- Control Box to be fixed in LV Switchgear Room on first floor in switchyard control building as indicated by TANGEDCO based on control building layout and feasibility, for monitoring system operation, automatic control and remote operation, with alarms indication, light switches, push buttons, audio signal, suitable for tripping and signalling on 220 DC supply.
- Signal box will be terminating cable connections from PRV/ pressure sensor, PNRV/POBV, fire detectors and circuit breaker trip signal.
- Pre-stressed non-return valve (PNRV)/ high speed pneumatically operated ball valve (POBV) shall be provided with sufficient number of NC contacts for remote alarm indication and with visual position indicator.
- Fire detectors rated for heat sensing at 141°C or suitable temperature recommended by the manufacturer and each fitted with two nos. PG 13.5 size cable glands.
- FRLS cable of size 12C X 1.5 mm² to be used for connecting signal box mounted on Reactor to Control Box in the station control room, Relay Panel to Control Box and Control Box to FE Cubicle.
- FRLS cable of size 4C X 1.5 mm² to be used for connecting PNRV / POBV to signal box, AC supply to FE Cubicle, AC & DC supply to Control Box, interconnection of AC & DC supply and connections in Relay Panel.

	CLIENT – TAMILNADU GENERATION & DISTRIBUTION CORPORATION LTD.	TB-400-552-126
	CONSULTANT- TATA CONSULTING ENGINEERS LIMITED BEGALURU	Rev. 00
	PROJECT: 2X660MW UDANGUDI STPP – (STAGE-1)	Page 5
TECHNICAL SPECIFICATION FOR NITROGEN INJECTION FIRE PROTECTION SYSTEM		

- Cable trays, if required, of suitable size as per the type of Cable used along with necessary hardware for fixing the same on walls or elsewhere shall be included by the bidders in their offers.
- Earthing of various equipment shall be in contractor's scope, however GI flat shall be provided by BHEL on free issue basis. Bidders shall furnish their tentative requirements in their respective bids.
- Bidders shall consider only reputed makes of equipments. All makes shall be subjected to acceptance of final customer. No additional price implication shall be made to BHEL on account of non-acceptance of proposed makes during contract stage.
- Bidder shall consider following items also while quoting:
 - i. Cable glands, lugs, marker, and cable ties etc. for termination of power and control cables.
 - ii. Fixing hardware for mounting various equipments in the system and cable trays etc.
- ***Bidder shall consider sufficient tools and tackles, which shall be brought to site for erection & commissioning purpose (to be returned after completion of work).***

1.6.2 SCOPE OF SERVICES

1.6.2.1 CIVIL WORKS:

Any minor Civil Work, supply of Inserts and Foundation Bolts required if any, required for complete and successful installation of Nitrogen Injection System is in the scope of Contractor and is deemed to be included in the quoted prices.

1.6.2.2 Erection, Testing & Commissioning (ETC) requirements

- a. The scope of ETC shall include erection of equipment /material at site including fabrication, equipment/ system testing and commissioning of the entire system.
- b. Laying and termination of piping between Reactor, FE cubicle and drain pit along with supports and fittings.
- c. Laying and termination of power and control cables for the equipment under the scope this specification.
- d. Laying & fixing of cable trays on walls or elsewhere, if required.
- e. Earthing of all the system components (equipments) to the nearest earth mat riser of the Owner / Purchaser.
- f. The contractor shall arrange all machinery, tools & tackles and consumables required for erection of the system.
- g. Contractor shall ensure that sufficient quantity of commissioning spares is made available for timely completion of commissioning of the system. The contractor shall furnish a list of commissioning spares that will be brought by him. The unused commissioning spares shall be returnable to the Contractor.
- h. Water and 415 V power shall be made available by purchaser at one point. Contractor shall be required to make own arrangement for taking supplies from there as per tender terms and conditions.
- i. It is the responsibility of the successful Bidder to obtain necessary approval/ clearance from statutory organizations wherever applicable for the equipment/ systems under the scope specified.
- j. The contractor shall train engineers of Purchaser/ Owner so that they are fully conversant with both electrical and mechanical part of the package.
- k. The contractor shall furnish the operation and maintenance manual for the system. The draft O&M manual shall be submitted within 4 weeks after award of contract. The O&M manual shall contain the following information:
 - i) Description of the system and equipment with design particulars.
 - ii) Scheme of operation for prevention of tank explosion and fire protection alongwith a flowchart showing sequence and time of operation of various devices of the system.
 - iii) Instruction for installation, operation, maintenance and repair at site.
 - iv) Recommended inspection practices and inspection schedule.
 - v) List of Recommended Spares.

	CLIENT – TAMILNADU GENERATION & DISTRIBUTION CORPORATION LTD.	TB-400-552-126
	CONSULTANT- TATA CONSULTING ENGINEERS LIMITED BEGALURU	Rev. 00
	PROJECT: 2X660MW UDANGUDI STPP – (STAGE-1)	Page 6
TECHNICAL SPECIFICATION FOR NITROGEN INJECTION FIRE PROTECTION SYSTEM		

vi) Ordering information for all replaceable parts.

1.6.2.3 Installation & pre-commissioning test of Nitrogen Injection Fire Protection System:

After installation the system pre-commissioning tests shall be carried out jointly with customer/BHEL before the system is put in service.

1.7 Provisions with Reactor for installation of Nitrogen Injection Fire Protection System:

Following provisions shall be provided by BHEL with each Reactor for installation of Nitrogen Injection Fire Protection System:

- Oil drain opening with pipe, flange and manual gate valve at about 100 - 150 mm below the top cover.
- Nitrogen Injection openings with suitable size of pipe with flanges and manual gate valves on tank sides at about 50 - 200 mm from the bottom plate.
- Flanges on conservator pipe between Buchholz relay and conservator tank for fixing PNRV/POBV.
- Provision for temperature and pressure sensors if required.
- Supply and welding of fire detector bracket on top cover.
- Supply and welding of brackets for fixing signal box at a suitable location on top cover or tank side wall.

Bidder shall confirm adequacy of the above arrangements on Reactor. Any other requirement for modification needed in the Reactor Design shall be brought out clearly in the bid itself. Bidder shall also provide relevant drawings for recommended / desired size of Brackets for mounting Fire Detectors, Brackets for fixing Signal Box etc. along with any other information as may be necessary to make required modifications on Reactor for purpose of successful and complete installation of Nitrogen Injection Fire Protection System.

1.8 EXCLUSIONS

1.8.1 Construction of foundation and plinth for fire extinguishing cubicle. However, the necessary details and drawings shall be furnished by contractor.

1.8.2 Construction of RCC / Brick Oil Pits near Reactor.

1.8.3 Supply of BUCHHOLZ relay.

1.8.4 Supply of GI flat for earthing of equipments.

1.8.5 Construction of Safety Wall / fire wall for Reactor.

1.8.6 Any Trench Related work for lying of Cables in Switchyard.

1.8.7 Set of Gate valves needed for Reactor Package i. e. 25 NB Gate valves for Nitrogen Injection openings at a distance of about 50 - 200 mm from Bottom Plate and 150NB Gate valve for Oil Drain on top about 100 - 150 mm below top cover.

(Apart from the Valves mentioned in Clause 1.8.7, all other Valves related to exclusively to Nitrogen Injection System in line with scope of supply, are to be included in Bidder's offer).

1.9 NIFPS based on alternate proven technology shall also be acceptable.

Note: Bidder's offer will be technically acceptable subject to final acceptance of vendor by ultimate customer as approved supplier.

1.10 INSPECTION & TESTING

All the equipments shall be inspected prior to dispatch in line with relevant IS, Approved GTP/ drawing and technical specification, BHEL/ customer approved QAP. Testing, demonstration and

	CLIENT – TAMILNADU GENERATION & DISTRIBUTION CORPORATION LTD.	TB-400-552-126
	CONSULTANT- TATA CONSULTING ENGINEERS LIMITED BEGALURU	Rev. 00
	PROJECT: 2X660MW UDANGUDI STPP – (STAGE-1)	Page 7
TECHNICAL SPECIFICATION FOR NITROGEN INJECTION FIRE PROTECTION SYSTEM		

installation and commissioning of all the units of Reactor Fire prevention system (By injecting nitrogen gas devices) shall be carried out at the site in presence of TANGEDCO/BHEL representatives and necessary training shall also be arranged for TANGEDCO staffs.

1.11 QUALITY PLAN

The contractor shall carry out contract works in accordance with sound quality management principles which shall include such as controls which are necessary to ensure full compliance to all requirements of the specification & applicable international standards. These quality management requirements shall apply to all activities during design, procurement, manufacturing, inspection, testing, packaging, shipping, inland transportation, storage, site erection & commissioning. Contractor shall submit detailed Quality Plan for BHEL / TANGEDCO approval.

1.12 DRAWING AND DOCUMENTATION

All drawings, data, design calculations & printed erection, operation & maintenance manual and other documents will be submitted by the Contractor as per activity schedule filled up by contractor during bidding stage.

1.13 TEST:

Type Tests

The test reports including that for detectors along with declared response time as per TAC's letter shall be submitted along with the drawings for approval. Certificates of the test on the system carried out by national / international testing bodies and TAC's approval, if any, shall also be submitted with the drawings for approval.

Factory Test

Tests will be carried out on individual equipment of the system, as applicable and the total system in the supplier's workshop in presence of purchaser's representative.

Performance Test:

Performance test of the complete system shall be carried out after complete erection at site by the supplier representative.

These tests shall include simulation and verification of the response of the complete system without injection of the Nitrogen gas.

1.14 HANDING AND TAKING OVER

It is the responsibility of Contractor to maintain the system till it is handed over to the owner. Pre commissioning tests shall be carried jointly with the Purchaser's / Owner's representative prior to handing over the system. Any additions/correction required for suitable operation of nitrogen injection fire prevention system before handing over to customer shall be done by contractor without any extra cost to BHEL.

1.15 Bidder shall quote under the following heads:

Sl. No.	Item Description	Unit	Quantity	Unit Ex-Works	Total Ex-Works	Unit ETC	Total ETC	Remarks
1.	NITROGEN INJECTION FIRE PROTECTION SYSTEM FOR 125 MVAR REACTOR	Nos.	02					COMPLTE WITH FIRE EXTINGUISHING CUBICLE WITH NITROGEN GAS CYLINDER, FIRE DETECTORS, FIRE SURVIVAL CABLE, CONTROL BOX,

864340/2022/TBG-TB ENG SR

	CLIENT – TAMILNADU GENERATION & DISTRIBUTION CORPORATION LTD.	TB-400-552-126
	CONSULTANT- TATA CONSULTING ENGINEERS LIMITED BEGALURU	Rev. 00
	PROJECT: 2X660MW UDANGUDI STPP – (STAGE-1)	Page 8
TECHNICAL SPECIFICATION FOR NITROGEN INJECTION FIRE PROTECTION SYSTEM		

							SIGNAL BOX, PNRV AND ALL OTHER FITTINGS AND ACCESSORIES
2.	FIRE RETARDANT LOW SMOKE (FRLS), 4CORE X 1.5 SQ .MM, ARMoured COPPER CABLE	Mtr.	150				
3.	FIRE RETARDANT LOW SMOKE (FRLS), 12CORE X 1.5 SQ.MM, ARMoured COPPER CABLE	Mtr.	600				
4.	PIPES AND CONNECTION FITTINGS WITH SUPPORT	Set	02				REACTOR-FEC-OIL PIT
5.	MANDATORY SPARES						
i.	FILLED NITROGEN CYLINDER	Nos.	01				CAPACITY OF NITROGEN CYLINDER SHOULD BE SAME AS OF MAIN SUPPLY
ii.	HOSE PIPES WITH FITTINGS	Set	01				1 SET CONSIST OF 2 NOS. OF HOSE PIPES WITH FITTINGS.
iii.	FIRE DETECTORS	Nos.	02				ALONGWITH SENSORS AND OTHER ACCESSORIES.

NOTE:

- Price of items like pipe fittings, hardware items etc. shall be considered along with price of the respective pipes/ items in the price schedule.
- The equipments and services to be furnished under this contract are detailed here under Cl. No. 1.15 of this section is for reference. Bidders shall work out the actual requirement based on the building & switchyard layout enclosed with this specification during detailed engineering stage.
- The Bill of Quantities shall be read in conjunction with the Instructions to Bidders, General and Special Conditions of Contract, Technical Specifications, and Drawings.
- The quantities given in the Bill of Quantities are estimated and provisional, and are given to provide a common basis for bidding. The basis of payment will be the actual quantities of work ordered and carried out, as measured by the Contractor and verified by the Purchaser and valued at the rates and prices bid in the priced Bill of Quantities.
- A rate or price shall be entered against each item in the priced Bill of Quantities. The cost of Items against which the Contractor has failed to enter a rate or price shall be deemed to be covered by other rates and prices entered in the Bill of Quantities.

864340/2022/TBG-TB ENG SR

	CLIENT – TAMILNADU GENERATION & DISTRIBUTION CORPORATION LTD.	TB-400-552-126
	CONSULTANT- TATA CONSULTING ENGINEERS LIMITED BEGALURU	Rev. 00
	PROJECT: 2X660MW UDANGUDI STPP – (STAGE-1)	Page 9
TECHNICAL SPECIFICATION FOR NITROGEN INJECTION FIRE PROTECTION SYSTEM		

- f) The whole cost of complying with the provisions of the Contract shall be included in the Items provided in the priced Bill of Quantities, and where no Items are provided, the cost shall be deemed to be distributed among the rates and prices entered for the related Items of Work.
- g) General directions and descriptions of work and materials are not necessarily repeated nor summarized in the Bill of Quantities. References to the relevant sections of the Contract documentation shall be made before entering prices against each item in the priced Bill of Quantities.
- h) Miscellaneous items like hardware, fixtures, fittings etc. shall be deemed to be included under the relevant BOQ items and bidders shall consider the same while quoting for BOQ items.
- i) Exact requirements shall be worked out during detailed engineering after award of contract.

	CLIENT – TAMILNADU GENERATION & DISTRIBUTION CORPORATION LTD.	TB-400-552-126
	CONSULTANT- TATA CONSULTING ENGINEERS LIMITED BEGALURU	Rev. 00
	PROJECT: 2X660MW UDANGUDI STPP – (STAGE-1)	Page 1
TECHNICAL SPECIFICATION FOR NITROGEN INJECTION FIRE PROTECTION SYSTEM		

SECTION - 2 EQUIPMENT SPECIFICATION

2.0 Design requirement

Each oil filled reactor shall be provided with a dedicated Nitrogen Injection system for prevention against the reactor explosion which shall use nitrogen as quenching medium. The system shall prevent reactor oil tank explosion and possible fire in case of internal / external cause. In the event of fire by external causes such as bushing fire, OLTC fires, fire from surrounding equipment etc., it shall act as a fast and effective fire fighter. It shall accomplish its role as fire preventer and extinguisher without employing water or carbon dioxide. Fire shall be extinguished within reasonable time (not more than 3 minutes so as not to harm the reactor) of system activation and within 30 seconds (maximum) of commencement of nitrogen injection.

2.1 Activation of the system

Mal-functioning of the Nitrogen injection system could lead to interruption in power supply. The supplier shall ensure that the probabilities of chances of malfunctioning of the Nitrogen injection system are practically zero. To achieve this objective, the supplier shall plan out scheme of activating signals which should not be too complicated to make the system inoperative in case of actual need. The system shall be provided with automatic controls to prevent the explosion of reactors. Besides automatic control, remote electrical push button control at Control box and local manual control in the cubicle shall also be provided.

The following electrical-signals shall be used for activating the system under prevention mode/fire extinguishing mode.

A) Auto Mode

For prevention:

- Differential relay operation.
- Buchholz relay paralleled with pressure relief valve or RPRR (Rapid Pressure Rise Relay)
- Tripping of all circuit breakers (on HV & LV side) associated reactor is the pre-requisite for activation of system.

For extinguishing

- Fire Detector
 - Buchholz relay paralleled with pressure relief valve or RPRR (Rapid Pressure Rise Relay).
- Tripping of all circuit breakers (on HV & LV side) associated with reactor is the pre-requisite for activation of system.

B) Manual Mode (Local / Remote)

Tripping of all circuit breakers (on HV & LV side) associated with reactor is the pre-requisite for activation of system.

C) Manual Mode (Mechanical)

Tripping of all circuit breakers (on HV & LV side) associated with reactor is the pre-requisite for activation of system. The system shall be designed to be operated manually in case of failure of power supply to the system.

2.2 General description

Nitrogen Injection system should be a dedicated system for each oil filled reactor. It should have a Fire Extinguishing Cubicle (FEC) placed on a plinth at a distance of 5-10 m away from reactor or placed



CLIENT – TAMILNADU GENERATION & DISTRIBUTION CORPORATION LTD.

TB-400-552-126

CONSULTANT- TATA CONSULTING ENGINEERS LIMITED BEGALURU

Rev. 00

PROJECT: 2X660MW UDANGUDI STPP – (STAGE-1)

Page | 2

TECHNICAL SPECIFICATION FOR NITROGEN INJECTION FIRE PROTECTION SYSTEM

next to the firewall (fire-fighting wall). The FEC shall be connected to the top of reactor oil tank for depressurization of tank and to the oil pit (capacity is approximately equal to 10% of total volume of oil in reactor tank from its bottom through oil pipes. The FEC should house a pressurized nitrogen cylinder(s) which is connected to the reactor oil tank at bottom. The Pre-stressed non-return valve (PNRV)/ high speed pneumatically operated ball valve (POBV) is fitted between the conservator tank and Buchholz relay. Cable connections are to be provided from signal box to the control box in the control room, from control box to FEC and from PNRV to signal box. Detectors placed on the top of reactor tank are to be connected in parallel to the signal box by Fire survival cables. Control box is also to be connected to relay panel in control room for receiving system activation signals.

2.3 Operation

On receipt of all activating signals, the system shall drain – predetermined volume of hot oil from the top of tank (i.e. top oil layer), through outlet valve, to reduce tank pressure by removing top oil and simultaneously injecting nitrogen gas at high pressure for stirring the oil at pre-fixed rate and thus bringing the temperature of top oil layer down. PNRV blocks the flow of oil from conservator tank in case of tank rupture / explosion or bushing bursting. Nitrogen occupies the space created by oil drained out and acts as an insulating layer over oil in the tank and thus preventing aggravation of fire.

2.4 System components

Nitrogen Injection system shall broadly consist of the following components. However, all other components which are necessary for fast reliable and effective working of the system shall deemed to be included in the scope of supply.

2.4.1 Cubicle (FEC)

The Cubicle Frame shall be made of CRCA sheet of 3 mm (minimum) thick complete with the base frame, painted inside and outside with post office red colour (shade 538 of IS -5). It shall have hinged / hinged split doors fitted with high quality tamper proof lock. The doors, removable covers and panels shall be gasketed all round with neoprene gaskets. The degree of protection shall be IP55. The following items shall be provided in the Cubicle.

- a. Nitrogen gas cylinder with regulator and falling pressure electrical contact manometer
- b. Oil drain pipe with mechanical quick drain valve.
- c. Electro mechanical control equipment for draining of oil of predetermined volume and injecting regulated volume of nitrogen.
- d. Pressure monitoring switch for back-up protection for nitrogen release.
- e. Limit switches for monitoring of the system.
- f. Butterfly valve with flanges on the top of panel for connecting oil drain pipe and nitrogen injection pipes for reactors.
- g. Panel lighting (CFL Type)
- h. Oil drain pipe extension of suitable sizes for connecting pipes to oil pit.
- i. Space heater.

2.4.2 Control box

Control box is to be placed in the control room for monitoring system operation, automatic control and remote operation. The following alarms, indications, switches, push buttons, audio signal etc. shall be provided.

- a. System On
- b. PNRV open
- c. Oil drain valve closed



CLIENT – TAMILNADU GENERATION & DISTRIBUTION CORPORATION LTD.

TB-400-552-126

CONSULTANT- TATA CONSULTING ENGINEERS LIMITED BEGALURU

Rev. 00

PROJECT: 2X660MW UDANGUDI STPP – (STAGE-1)

Page | 3

TECHNICAL SPECIFICATION FOR NITROGEN INJECTION FIRE PROTECTION SYSTEM

- d. Gas inlet valve closed
- e. PNRV closed
- f. Detector trip
- g. Buchholz relay trip
- h. Oil drain valve open
- i. Extinction in progress
- j. Cylinder pressure low
- k. Differential relay trip
- l. PRV / RPRR trip
- m. Reactor trip
- n. System out of service
- o. Fault in cable connecting fault detector
- p. Fault in cable connecting differential relay
- q. Fault in cable connecting Buchholz relay
- r. Fault in cable connecting PRV / RPRR
- s. Fault in cable connecting reactor trip
- t. Fault in cable connecting TCIV
- u. Auto / Manual / Off
- v. Extinction release on / off
- w. Lamp test
- x. Visual / Audio alarm for AC supply fail
- y. Visual / Audio alarm for DC supply fail

As far as possible the control box should be such devised that all the reactors or group thereof should be controlled from single spot.

2.4.3 Pre-Stressed Non-Return Valve.

Pre-Stressed Non-Return Valve (PNRV) to be fitted in the conservator pipe line, between conservator and buchholz relay which shall operate for isolating the conservator during abnormal flow of oil due to rupture / explosion of tank or bursting of bushing. The valve shall not isolate conservator during normal flow of oil during filtration or filling or refilling, locking plates to be provided with handle for pad locking. It shall have proximity switch for remote alarm, indication with visual position indicator. The PNRV should be of the best quality as malfunctioning of PNRV could lead to serious consequence. The closing of PNRV means stoppage of breathing of transformer. Locking plates shall be provided for pad locking.

2.4.4 Detectors.

The system shall be completing with adequate number of detectors (quartz bulb) fitted on the top cover of the reactor oil tank.

2.4.5 Signal box

It shall be mounted away from reactor main tank, preferably near the reactor marshalling box, for terminating cable connections from PNRV & detectors and for further connection to be control box. The degree of protection shall be IP55.

2.4.6 Cables

Fire survival cables (capable to withstand 750° C.) of 4 core x 1.5 sq. mm size for connection of detectors in parallel shall be used. The fire survival cable shall conform to BS 7629-1, BS 8434-1, BS 7629-1 and BS 5839-1, BS EN 50267-2- 1 or relevant Indian standards. Fire Retardant Low Smoke (FRLS) cable of adequate size shall be used for connection of signal box / marshalling box near reactor and FEC mounted near reactor with control box mounted in control room. Fire Retardant Low Smoke

	CLIENT – TAMILNADU GENERATION & DISTRIBUTION CORPORATION LTD.	TB-400-552-126
	CONSULTANT- TATA CONSULTING ENGINEERS LIMITED BEGALURU	Rev. 00
	PROJECT: 2X660MW UDANGUDI STPP – (STAGE-1)	Page 4
TECHNICAL SPECIFICATION FOR NITROGEN INJECTION FIRE PROTECTION SYSTEM		

(FRLS) cable of 4 core x 1.5 sq. mm size shall be used for connection between control box to DC & AC supply source, FEC to AC supply source, signal box / marshalling box to PNRV connection on reactor. Separate cables for AC supply & DC supply shall be used.

2.4.7 Pipes

Pipes complete with connections, flanges, bends and tees etc. shall be supplied along with the system.

2.5 Other items to be supplied

- Oil drain and nitrogen injection openings with gate valves on reactor tank at suitable locations.
- Flanges between Buchholz relay and conservator tank for fixing PNRV.
- Detector brackets on reactor tank top cover.
- Spare potential free contacts activating the system i.e. in differential relay, Bucholz relay, Pressure Relief Device / RPRR, Circuit breaker of reactor.
- Pipe connections between reactor and FEC and between FEC and oil pit required for collecting top oil.
- Cabling for detectors mounted on reactor top cover.
- Inter cabling between signal box, control box and FEC.
- Butterfly valves / Gate valves on oil drain pipe and nitrogen injection pipe which should be able to withstand full vacuum.
- Supports, signal box etc. which are to be painted with enameled paint.
- Any other item required for satisfactory operation of system.

2.6 Power supply

For Control Box 220 V DC
For FEC Auxiliary 230 V AC

2.7 Performance of Reactor

The performance requirement shall be paramount importance and shall form the essence of the contract. However, in any case, performance of reactor should not be affected in any manner by having Nitrogen Injection Fire Prevention Cum Extinguishing System (NIFPES). Contractor shall give an undertaking to this effect.

All pipes should be washed / rinsed with reactor oil. If any damage is done to the reactor and / or any connected equipment during installation & commissioning full recovery therefore shall be effected from the Contractor.

It shall be solely the responsibility of Contractor to install, carry out pre-commissioning tests & commission NIFPES, to the entire satisfaction of the TANGEDCO.

2.8 Interlocks

It shall be ensured that once the NIFPES gets activated manually or in auto mode, all the connected breakers shall not close until the system is actually put in OFF mode. Also PRV shall get closed only if all the connected breakers are open.

2.9 Tests

Contractor has to carry out the type test as per relevant IS/IEC. Specifically IP 55 on FEC or have to produce the report from NABL approved Lab. Reports of all routine test conducted as per relevant



CLIENT – TAMILNADU GENERATION & DISTRIBUTION CORPORATION LTD.

TB-400-552-126

CONSULTANT- TATA CONSULTING ENGINEERS LIMITED BEGALURU

Rev. 00

PROJECT: 2X660MW UDANGUDI STPP – (STAGE-1)

Page | 5

TECHNICAL SPECIFICATION FOR NITROGEN INJECTION FIRE PROTECTION SYSTEM

IS/IEC standards in respect of various bought out items including test reports for degree of protection for FEC / control box / signal box shall be submitted by the supplier.

A) Factory Acceptance Tests

The supplier shall demonstrate the entire functional test associated with the following as Factory Acceptance Tests:

- FEC, Control Box
- Fire Detector
- PNRV

B) Performance test

The performance test of the complete system shall be carried out after erection of the system with reactor at site.

2.10 Drawings and Manuals

Detailed layout drawings, equipment drawing along with Operation and Maintenance manual as specified in general condition of this specification along with soft copies shall be submitted by the supplier along with the consignment.

2.11 Mandatory Spares

The following mandatory spares may be supplied along with recommended mandatory spares if any, for the entire system at free cost:

- a) 1 No. filled nitrogen cylinder of each capacity/size for reactor
- b) 1 Set of hose pipes with fittings of each capacity/size for reactor
- c) 2 Nos. complete fire detectors alongwith sensors and other accessories

	CLIENT – TAMILNADU GENERATION & DISTRIBUTION CORPORATION LTD.	TB-400-552-126
	CONSULTANT- TATA CONSULTING ENGINEERS LIMITED BEGALURU	Rev. 00
	PROJECT: 2X660MW UDANGUDI STPP – (STAGE-1)	Page 1
TECHNICAL SPECIFICATION FOR NITROGEN INJECTION FIRE PROTECTION SYSTEM		

SECTION-3 PROJECT DETAILS AND GENERAL SPECIFICATIONS

3.0 GENERAL

This section stipulates the General Technical Requirements under the contract and will form an integral part of the Technical Specification.

The provisions under this section are intended to supplement general requirements for the materials, equipment and services covered under other sections and are not exclusive. However in case of conflict between the requirements specified in this section and requirements specified under other sections, the requirements specified under respective sections shall hold good.

3.1 SITE INFORMATION

SL.NO.	DESCRIPTION	
3.1	PROJECT INFORMATION	
	a) Customer	Tamil Nadu Generation and Distribution Corporation (TANGEDCO)
	b) Project	400kV GIS at 2 x 660 MW Udangudi STPP (Stage-I)
	c) Project location	
	i) Country	India
	ii) State	Tamil Nadu
	iii) Administrative district	Thoothukudi
	iv) Next Big cities to site	Thoothukudi (approx.. 45 kms from site)
	v) Road access	East Coast Road- State high way (176)
	vi) Nearest Railway Station	Thiruchendur (approx.. 12 kms from site)
	vii) Nearest Airport	Vaigai (approx.. 60 kms)



CLIENT – TAMILNADU GENERATION & DISTRIBUTION CORPORATION LTD.
 CONSULTANT- TATA CONSULTING ENGINEERS LIMITED BEGALURU
 PROJECT: 2X660MW UDANGUDI STPP – (STAGE-1)
 TECHNICAL SPECIFICATION FOR NITROGEN INJECTION FIRE PROTECTION SYSTEM

TB-400-552-126

Rev. 00

Page | 2

		from site)
	viii) Nearest Harbour	Tuticorin (approx.. 45 kms from site)
3.2	SITE CONDITIONS	
3.2.1	Ambient Air Temp.	
	a) Maximum dry bulb temp. (max.) °C	41°C
	b) Minimum dry bulb temp. (min.) °C	17°C
	Design ambient temperature	50°C
3.2.2	Relative humidity	
	Mean Maximum humidity (Summer)	84 %
	Mean Minimum humidity (Summer)	62 %
	Maximum humidity (Monsoon)	97%
	Minimum humidity (Monsoon)	45%
3.2.3	Rain fall	
	Annual rainfall (Maximum)	718.2 mm
	Annual rainfall (Minimum)	384.1 mm
	Twenty four (24) Hour max	138.2 mm
3.2.4	High Flood Level	
	High Flood Level for site	RL 2.450 m
3.2.5	Wind	
	Mean Wind Speed (max)	39 m/sec (As per IS: 875)
	Wind direction	North, North east, North west, East
3.3	Seismic intensity	
	Seismic Intensity	As per IS:1893 Latest
	Zone	II

3.2 INSTRUCTION TO BIDDERS

The bidders shall submit the technical requirements, data and information as per the technical data sheets, provided in Section-4.

The bidders shall furnish catalogues, engineering data, technical information, design documents, drawings etc fully in conformity with the technical specification.

	CLIENT – TAMILNADU GENERATION & DISTRIBUTION CORPORATION LTD.	TB-400-552-126
	CONSULTANT- TATA CONSULTING ENGINEERS LIMITED BEGALURU	Rev. 00
	PROJECT: 2X660MW UDANGUDI STPP – (STAGE-1) TECHNICAL SPECIFICATION FOR NITROGEN INJECTION FIRE PROTECTION SYSTEM	Page 3

It is recognized that the Manufacturer may have standardized on the use of certain components, materials, processes or procedures different than those specified herein. Alternate proposals offering similar equipment based on the manufacturer's standard practice will also be considered provided such proposals meet the specified designs, standard and performance requirements and are acceptable to the Purchaser. Unless brought out clearly, the Bidder shall be deemed to conform to this specification scrupulously.

3.3 STANDARDS

The works covered by the specification shall be designed, engineered, manufactured, built, tested and commissioned in accordance with the Acts, Rules, Laws and Regulations of India.

The equipment to be furnished under this specification shall conform to latest issue (with all amendments) of specified standards.

In addition to meeting the specific requirement called for in Sections 1 and 2 of the Technical Specification, the equipment shall also conform to the general requirement of the applicable standards, which shall form an integral part of the specification.

The Bidder shall note that standards mentioned in the specification are not mutually exclusive or complete in themselves, but intended to complement each other.

When the specific requirements stipulated in the specifications exceed or differ from those required by the applicable standards, the stipulation of the specification shall take precedence.

Other internationally accepted standards, which ensure equivalent or better performance than that specified in the standards referred, shall also be accepted. The bidder shall submit copies of such standards.

In case governing standard for the equipment is different from IS or IEC, the salient points of difference shall be clearly brought out in the offer along with English language version of standard or relevant extract of the same. The equipment conforming to standards other than IS/IEC shall be subject to Purchaser's / owner's approval.

	CLIENT – TAMILNADU GENERATION & DISTRIBUTION CORPORATION LTD.	TB-400-552-126
	CONSULTANT- TATA CONSULTING ENGINEERS LIMITED BEGALURU	Rev. 00
	PROJECT: 2X660MW UDANGUDI STPP – (STAGE-1)	Page 4
TECHNICAL SPECIFICATION FOR NITROGEN INJECTION FIRE PROTECTION SYSTEM		

The bidder shall clearly indicate in his bid the specific standards in accordance with which the works will be carried out.

3.4 SERVICES TO BE PERFORMED BY THE EQUIPMENT BEING FURNISHED

All equipment shall also perform satisfactorily under various other electrical, electro mechanical and meteorological conditions of the site of installation All equipment shall be able to withstand all external and internal mechanical, thermal and electro mechanical forces due to various factors like wind load, temperature variation, ice & snow, (wherever applicable) short circuit etc for the equipment.

3.5 ENGINEERING DATA

3.5.1 Drawings

The Supplier shall necessarily submit all the drawings/ documents unless anything is waived. The Supplier shall submit drawings/ design documents/ data/ test reports/manuals as may be required for the approval of the purchaser. All drawings submitted by the Manufacturer including those submitted at the time of bid shall be in sufficient detail to indicate the type, size, arrangement, material description, Bill of Materials, weight of each component, break-up for packing and shipment, the external connections, fixing arrangement required. The dimensions required for installation and interconnections with other equipment and materials, clearances and spaces required for installation and interconnections between various portions of equipment and any other information specifically requested in the specifications.

Each drawing submitted by the Manufacturer shall be clearly marked with the name of the Purchaser, the unit designation, the specifications title, the specification number and the name of the Project. If standard catalogue pages are submitted, the applicable items shall be indicated therein. All titles, noting, markings and writings on the drawing shall be in English. All the dimensions should be in metric units.

Further work by the Manufacturer shall be in strict accordance with these drawings and no deviation shall be permitted without the written approval of the Purchaser, if so required.

The review of these data by the Owner will cover only general conformance of the data to the specifications and documents, interfaces with the equipment

	CLIENT – TAMILNADU GENERATION & DISTRIBUTION CORPORATION LTD.	TB-400-552-126
	CONSULTANT- TATA CONSULTING ENGINEERS LIMITED BEGALURU	Rev. 00
	PROJECT: 2X660MW UDANGUDI STPP – (STAGE-1)	Page 5
TECHNICAL SPECIFICATION FOR NITROGEN INJECTION FIRE PROTECTION SYSTEM		

provided under the specifications, external connections and of the dimensions which might affect substation layout. Owner may not indicate a thorough review of all dimensions, quantities and details of the equipment, material, any devices or items indicated or the accuracy of the information submitted. This review and /or approval by the Owner shall not be considered by the Manufacturer, as limiting any of his responsibilities and liabilities for mistakes and deviations from the requirements, specified under these specifications and documents.

All manufacturing and fabrication work in connection with the equipment prior to the approval of the drawings shall be at the Manufacturer's risk. The Manufacturer may make any changes in the design which are necessary to make the equipment conform to the provisions and intent of the Contract and such changes will again be subject to approval by the Purchaser. Approval of Manufacturer's drawing or work by the Purchaser shall not relieve the manufacturer of any of his responsibilities and liabilities under the Contract.

All engineering data submitted by the Manufacturer after final process including review and approval by the Owner shall form part of the Contract Document and the entire works performed under these specifications shall be performed in strict conformity, unless otherwise expressly requested by the Owner in Writing.

The title block of drawings shall contain the following information incorporated in all contract drawings

Title block for project:

1. Customer : Tamil Nadu Generation and Distribution Corporation (TANGEDCO)			
2. Consultant : DESEIN PRIVATE LIMITED, DESEIN HOUSE, NEW DELHI			
3. Project : 400kV GIS at 2 x 660 MW Udangudi STPP (Stage-I)			
4.	Contract	No./LOA	No. :
Lr.No.CE/Proj.II/SE/C/UTPP/EE/E/LOI/D.179/2017, dt.07.12.2017			
5. Main Contractor : Bharat Heavy Electricals Limited			
6. BHEL Order No. & Date :			

3.5.2 Documentation

Document Distribution Schedule - After Placement of Order:



CLIENT – TAMILNADU GENERATION & DISTRIBUTION CORPORATION LTD.
 CONSULTANT- TATA CONSULTING ENGINEERS LIMITED BEGALURU
 PROJECT: 2X660MW UDANGUDI STPP – (STAGE-1)
 TECHNICAL SPECIFICATION FOR NITROGEN INJECTION FIRE PROTECTION SYSTEM

TB-400-552-126

Rev. 00

Page | 6

S. No.	Stage	No. of copies	
i)	Submission of Data sheets Datasheet, drawings, documents, write-ups, calculation, test reports, Preliminary	13	As per agreed schedule
ii)	Resubmission of above, if required	13	As per agreed schedule
iii)	Final approved documents	13	As per agreed schedule
iv)	Instruction manuals for erection and O&M	6	As per agreed schedule
v)	As built drawings including O & M manual -Hard copy -Soft copy in CD/Pendrive	13 6	As per agreed schedule

NOTES:

- a) The manufacturer may note that all re-submissions must incorporate all comments given in the prior submission by the Purchaser. Adequate justification for not incorporating the same must be submitted, failing which the submitted documents may be returned.

3.5.3 Format of Documentation

- a) All engineering documents and drawings shall be of international “A” series sizes, that is, A0, A1, A2, A3 and A4.
 b) Two set of CD/ pendrive containing all the drawings in Auto CAD shall also be supplied in addition to hard copies. Soft copy of all documents shall be supplied in a CD/pendrive in PDF format.
 c) Grouped documents shall be provided by size A4, with the inclusion of bigger size drawings which, however, have to be folded as Size A4.

3.5.4 Instruction manuals and operating manuals

The Supplier shall provide Instruction & Maintenance Manuals for each part of the Plant and Equipment included in the Works and Operating Manuals for each Station.

The Instruction Manuals and Operating Manuals shall be arranged in an

	CLIENT – TAMILNADU GENERATION & DISTRIBUTION CORPORATION LTD.	TB-400-552-126
	CONSULTANT- TATA CONSULTING ENGINEERS LIMITED BEGALURU	Rev. 00
	PROJECT: 2X660MW UDANGUDI STPP – (STAGE-1) TECHNICAL SPECIFICATION FOR NITROGEN INJECTION FIRE PROTECTION SYSTEM	Page 7

organized library adequately cross referenced to facilitate issuing clauses of the manuals as required by the work i.e. erection instructions shall be required before operating & maintenance instructions.

All Manuals provided by the Supplier shall be fully detailed and specifically prepared for the Works and equipment provided. General manuals not specifically required for the work shall not be acceptable.

The instruction manuals shall at least contain:

- a) A general description of all components
- b) Storage instructions
- c) Erection instructions
- d) Pre-commissioning Instruction:
- e) Material and part list.
- f) Design clearances and settings
- g) Complete sets of drawings as finally issued
- h) Operating Instructions:
- i) Routine and Preventive Maintenance instructions with material requirement for each site
- j) Preventive Maintenance Schedule.
- k) Replacement instruction for all equipment

The operation manuals shall at least contain:

- a) Operator oriented functional descriptions of the equipment.
- b) Operator oriented description of the protection and control systems
- c) Description of the equipment auxiliary systems
- d) Fault finding and diagnostic tools
- e) User software interface tools for modification/augmentation etc.

Notes:

The supplier may please note that all resubmissions must incorporate all comments given in the earlier submission by the Owner/Purchaser or adequate justification for not incorporating the same must be submitted failing which the submission of documents is likely to be returned.

If after the commissioning and initial operation of the substation, the instruction manuals require any modifications/ additions/changes, the same shall be incorporated and the updated final instruction manuals shall be submitted by the Supplier to the Owner/Purchaser.

	CLIENT – TAMILNADU GENERATION & DISTRIBUTION CORPORATION LTD.	TB-400-552-126
	CONSULTANT- TATA CONSULTING ENGINEERS LIMITED BEGALURU	Rev. 00
	PROJECT: 2X660MW UDANGUDI STPP – (STAGE-1) TECHNICAL SPECIFICATION FOR NITROGEN INJECTION FIRE PROTECTION SYSTEM	Page 8

The Supplier shall furnish to the Owner/Purchaser, catalogues of spare parts also.

3.6 QUALITY ASSURANCE PROGRAMME

This section contains general requirements for inspection of material, parts, equipment and workmanship during manufacture, assembling to demonstrate compliance with specification, codes and standards to ensure overall reliability of product operation and performance.

The Owner and/or authorized Representatives shall, at any time, be allowed free and ready access to the Contractor's premises and those of his suppliers as well as to the site installation and the Contractor has to make the items available for the purpose of inspection of the specified equipment components and obtaining information as to the progress of the work. Failure on the part of the Owner, at this or any other time, to discover or reject materials or work which do not meet specified requirements shall not be deemed an acceptance thereof nor a waiver of defects therein.

The approval of the Owner shall not prejudice the right to reject equipment if it does not give complete satisfaction in service.

To ensure that the equipment and services under the scope of this Contract, whether manufactured or performed within the Manufacturer's Works or at his Sub-manufacturer's premises or at the Purchaser's site or at any other place of Work, are in accordance with the specifications, the Manufacturer shall adopt a suitable quality assurance programme to control such activities at all points, as necessary.

Before manufacture commences and not later than 45 days after award of contract, the Contractor shall submit an outline of his proposed inspection program, which shall include all major stages during manufacturing. The inspection and test program shall include for the various items the designation No., name of equipment, part of equipment, the kind of test, test standard, company which carries out the test, place, date and witnesses by the Contractor, third party or Owner's Representative. The detailed manufacturer's quality assurance plan shall be subject to approval after award of contract.

The Owner will return a copy of the Contractor's proposed inspection program indicating those inspection stages for which notification is required. Notification shall be by Fax or email in a format to be agreed and shall be sent prior to the intended test. If the Owner intends to be represented at the test he will provide at least 24 hours' notice and if his representative does not attend on the notified date, an alternative date has to be informed by the Owner.

	CLIENT – TAMILNADU GENERATION & DISTRIBUTION CORPORATION LTD.	TB-400-552-126
	CONSULTANT- TATA CONSULTING ENGINEERS LIMITED BEGALURU	Rev. 00
	PROJECT: 2X660MW UDANGUDI STPP – (STAGE-1)	Page 9
TECHNICAL SPECIFICATION FOR NITROGEN INJECTION FIRE PROTECTION SYSTEM		

A quality assurance programme of the manufacturer shall generally cover the following:

- (a) Manufacturer's organisation structure for the management and implementation of the proposed quality assurance programme;
- (b) Documentation control system;
- (c) Qualification data of bidder's key personnel;
- (d) The procedure for purchases of materials, parts components and selection of sub-Manufacturer's services including vendor analysis, source inspection, incoming raw material inspection, verification of material purchases etc.
- (e) System for shop manufacturing and site erection controls including process controls and fabrication and assembly control;
- (f) Control of non-conforming items and system for corrective actions;
- (g) Inspection and test procedure both for manufacture and field activities;
- (h) Control of calibration and testing of measuring instruments and field activities;
- (i) System for indication and appraisal of inspection status;
- (j) System for quality audits;
- (k) System for authorising release of manufactured product to the Purchaser
- (1) System for maintenance of records;
- (m) System for handling storage and delivery; and
- (n) A quality plan detailing out the specific quality control measures and Procedures adopted for controlling the quality characteristics relevant to each item of equipment furnished and/or services rendered. The Purchaser or his duly authorised representative reserves the right to carry out quality audit and quality surveillance of the system and Procedure of the Manufacturer/his vendors quality management and control activities.

3.7 Quality Assurance Documents

The Manufacturer shall be required to submit all Quality Assurance Documents as stipulated in the quality plan at the time of purchaser's inspection of equipment/ material.

3.8 TYPE TESTING, INSPECTION, TESTING & INSPECTION CERTIFICATE

All equipment being supplied shall conform to type tests and shall be subject to routine and acceptance tests in accordance with requirements stipulated under respective sections. Purchaser reserves the right to witness any or all the tests. The Manufacturer shall intimate the Purchaser the detailed programme about the tests at least three (3) weeks in advance in case of domestic supplies & six (6) weeks in advance in case of foreign supplies. The

	CLIENT – TAMILNADU GENERATION & DISTRIBUTION CORPORATION LTD.	TB-400-552-126
	CONSULTANT- TATA CONSULTING ENGINEERS LIMITED BEGALURU	Rev. 00
	PROJECT: 2X660MW UDANGUDI STPP – (STAGE-1) TECHNICAL SPECIFICATION FOR NITROGEN INJECTION FIRE PROTECTION SYSTEM	Page 10

Manufacturer shall also submit type test procedure for approval of the Purchaser.

In the event of any discrepancy in the test reports i.e. any test report not acceptable due to any design/manufacturing changes (including substitution of components) or due to non-compliance with the requirement stipulated in the technical specification or any/all additional type tests not carried out, Such test shall be conducted fresh without any additional cost implication to the Purchaser.

The price of conducting all tests and additional type tests is deemed to be included in Bid price. In case any bidder indicates that he shall not carry out a particular test, his offer shall be considered incomplete and shall be liable to be rejected.

Inspection may be made at any stage of manufacture, dispatch or at site at the option of the Purchaser and the equipment if found unsatisfactory due to bad workmanship or quality, material is liable to be rejected.

The Purchaser or Inspector shall, within fifteen (15) days from the date of inspection as defined herein, give notice in writing to the Manufacturer, of any objection to any drawings and all or any equipment and workmanship which in his opinion is not in accordance with the Contract. The Manufacturer shall give due consideration to such objections and shall either make the modifications that may be necessary to meet the said objections or shall confirm in writing to the Purchaser/ inspector giving reasons therein, that no modifications are necessary to comply with the Contract.

When the factory tests have been completed at the Manufacturer's works, the Purchaser/inspector shall issue a certificate to this effect within fifteen (15) days after completion of tests but if the tests are not witnessed by the Purchaser/inspector, the certificate shall be issued within fifteen (15) days of receipt of the Manufacturer's Test certificate by the Engineer/ Inspector. Failure of the Purchaser/inspector to issue such a certificate shall not prevent the Manufacturer from proceeding with the Works. The completion of these tests or the issue of the certificate shall not bind the Purchaser to accept the equipment should it, on further tests/ after erection, be found not to comply with the Contract. The equipment shall be dispatched to site only after approval of test reports and issuance of MICC by the Purchaser.

In all cases where the Contract provides for tests whether at the premises or at the works of the Manufacturer or of any Sub-Contractor, the Manufacturer

	CLIENT – TAMILNADU GENERATION & DISTRIBUTION CORPORATION LTD.	TB-400-552-126
	CONSULTANT- TATA CONSULTING ENGINEERS LIMITED BEGALURU	Rev. 00
	PROJECT: 2X660MW UDANGUDI STPP – (STAGE-1) TECHNICAL SPECIFICATION FOR NITROGEN INJECTION FIRE PROTECTION SYSTEM	Page 11

except where otherwise specified shall provide free of charge such items as labour, materials, electricity, fuel, water, stores, apparatus and instruments as may be reasonably demanded by the Purchaser /Inspector or his authorised representative to carry out effectively such tests of the equipment in accordance with the Contract and shall give facilities to the Purchaser Inspector or to his authorised representative to accomplish testing.

The inspection by Purchaser and issue of Inspection Certificate thereon shall in no way limit the liabilities and responsibilities of the Manufacturer in respect of the agreed quality assurance programme forming a part of the Contract.

The Purchaser reserves the right for getting any field tests not specified in respective sections of the technical specification conducted on the completely assembled equipment at site. The testing equipment for these tests shall be provided by the Purchaser.

3.9 MATERIALS AND WORKMANSHIP

Equipment materials and components shall be new, of high grade and good quality and be to the latest engineering practice. The material and workmanship throughout shall be in accordance with the purpose for which they are intended. Each component shall be designed to be consistent with its duty.

All the information concerning materials or components to be used in manufacturing, machinery, equipment, materials and components supplied, installed or used shall be submitted for approval. Without such approval the supplier shall run risk of subsequent rejection. The cost as well as time delay associated with such rejection shall be borne by the supplier.

3.10 COLOUR SCHEME

The Supplier shall propose a colour scheme for the equipment for the approval of the Employer. The decision of the Employer shall be final. However, the finishing colour shall be RAL 7035 for all Control panels/ MCC/ Switchgear panels. The scheme shall include:

- Finishing colour of Indoor equipment
- Finishing colour of Outdoor equipment
- Finishing colour of various auxiliary system equipment including piping
- Finishing colour of various building items.
- Finishing colour of all cubicles.

	CLIENT – TAMILNADU GENERATION & DISTRIBUTION CORPORATION LTD.	TB-400-552-126
	CONSULTANT- TATA CONSULTING ENGINEERS LIMITED BEGALURU	Rev. 00
	PROJECT: 2X660MW UDANGUDI STPP – (STAGE-1)	Page 12
TECHNICAL SPECIFICATION FOR NITROGEN INJECTION FIRE PROTECTION SYSTEM		

All steel structures, plates etc shall be painted with non-corrosive paint on a suitable primer. The galvanised structures in the switchyard shall not be painted. However galvanised structures in other areas may require painting for aesthetic reasons.

3.11 PACKING AND STORAGE

Packing specification shall be submitted for BHEL/customer approval after award of contract.

All the equipment shall be suitably protected, coated, covered or boxed and crated to prevent damage or deterioration during transit, handling and storage at site till the time of erection. On request of the purchaser, the manufacturer shall also submit packing details/associated drawing for any equipment/material at a later date, in case the need arises. While packing all the materials, the limitation from the point of view of availability of Railway wagon sizes in India should be taken into account. The manufacturer shall be responsible for any loss or damage during transportation, handling and storage due to improper packing. Any demurrage, wharf age and other such charges claimed by the transporters, railways etc shall be to the account of the manufacturer. Purchaser takes no responsibility of the availability of the wagons.

All coated surfaces shall be protected against abrasions, impact, discoloration and any other damages. All exposed threaded portions shall be suitably protected with either a metallic or a non-metallic protecting device.

Supplier shall ensure that equipment shall be properly packed, blocked, padded, coated and protected so that it is not damaged due to possible mishandling. Storage requirements shall be clearly defined by the supplier. Packing shall be such that if required, long time storage (at least 1 year) at site should not deteriorate the performance of the equipment.

3.12 NAME PLATE

Name plates which are to be firmly fixed on all the equipment, buildings and structures shall be provided. For equipment of small size, these are to be fixed on the piping or structure adjacent to the equipment. The contents of nameplate are to include the designation and principal parameters of the equipment.

The nameplate within the field shall be made of a high temperature - resistant metallic

	CLIENT – TAMILNADU GENERATION & DISTRIBUTION CORPORATION LTD.	TB-400-552-126
	CONSULTANT- TATA CONSULTING ENGINEERS LIMITED BEGALURU	Rev. 00
	PROJECT: 2X660MW UDANGUDI STPP – (STAGE-1) TECHNICAL SPECIFICATION FOR NITROGEN INJECTION FIRE PROTECTION SYSTEM	Page 13

sheets, with designation permanently engraved on them. Indoor installed equipments (e.g., panels, cabinets, switchgear, etc.) shall also be labelled by appropriate name plate.

The form, size, base colour and colour of contents of the name plates and prompting plates will be agreed between the Contractor and the Owner. It shall be possible for these to be readily seen by the operator. The designation of warning tags shall be different from that of other tags.

The Equipment identification shall be finalized by vendor in consultation with BHEL/TANGEDCO and should be included in name plates.

3.13 CLAMPS & CONNECTORS

- i) All power clamps and connectors shall conform to IS: 5561, and/or IEC standard and shall be made of materials listed below:

a)	For connecting ACSR conductors	Aluminium alloy casting, conforming to designation A6 of IS: 617 and shall be tested for all tests as per IS:617
b)	For connecting equipment terminals made of copper with ACSR conductors	Bimetallic connectors made from aluminium alloy casting, conforming to designation A6 of IS 617 with 2 mm thick Bimetallic liner and shall be tested as per IS: 617.
c)	For connecting G.I. Shield wire	Galvanised mild steel
d).1	Bolts, nuts & Plain washers.	Electro galvanized for sizes below M12, for others hot dip galvanised
d).2	Spring washers for items 'a' to 'c'	Electro-galvanised mild steel suitable for at least service condition-3 as per IS: 1573

- ii) Equipment shall be supplied with the necessary terminals and connectors, as required by the ultimate design for the particular installation. The conductor terminations of equipment shall be either expansion, sliding or rigid type. The requirements regarding external corona and RIV as specified for any equipment shall include its terminal fittings and the equipment shall be factory tested with the connectors in position. In case the connector is not available then equivalent connector may be used. If corona rings are required to meet these requirements they shall be

	CLIENT – TAMILNADU GENERATION & DISTRIBUTION CORPORATION LTD.	TB-400-552-126
	CONSULTANT- TATA CONSULTING ENGINEERS LIMITED BEGALURU	Rev. 00
	PROJECT: 2X660MW UDANGUDI STPP – (STAGE-1) TECHNICAL SPECIFICATION FOR NITROGEN INJECTION FIRE PROTECTION SYSTEM	Page 14

considered as part of that equipment and included in the scope of Work.

- iii) Where copper to aluminium connections are required, bi-metallic clamps shall be used, which have been properly designed to ensure that any deterioration of the connection is kept to a minimum and restricted to parts which are not current t shall be furnished to the Employer.
- iv) Low voltage connectors, grounding connectors and accessories for grounding all equipment as specified are also included in the scope of Work.
- v) No current carrying part of any clamp shall be less than 10 mm thick. All ferrous parts shall be hot dip galvanised. Copper alloy liner of minimum 2mm thickness shall be cast integral with aluminium body for Bi-metallic clamps. When copper alloy is not cast integral with aluminium body, a bimetallic washer or strip shall be used to meet the functional requirement.
- vi) All casting shall be free from blow holes, surface blisters, cracks and cavities. All sharp edges and corners shall be blurred and rounded off.
- vii) Flexible connectors, braids or laminated straps made for the terminal clamps for bus posts shall be suitable for both expansion or through (fixed/sliding) type connection of IPS Aluminium tube as required. In both the cases the clamp height (top of the mounting pad to centre line of the tube) should be same.
- viii) Clamp shall be designed to carry the same current as the conductor and the temperature rise shall be equal or less than that of the conductor at the specified ambient temperature. The rated current for which the clamp/connector is designed with respect to the specified reference ambient temperature, shall also be indelibly marked on each component of the clamp/connector, except on the hardware.
- ix) All current carrying parts shall be designed and manufactured to have minimum contact resistance.

x) TESTS

The following is the list of type tests.

- a) Temperature rise test (maximum temperature rise allowed is 35deg C over 50 deg C ambient)

	CLIENT – TAMILNADU GENERATION & DISTRIBUTION CORPORATION LTD.	TB-400-552-126
	CONSULTANT- TATA CONSULTING ENGINEERS LIMITED BEGALURU	Rev. 00
	PROJECT: 2X660MW UDANGUDI STPP – (STAGE-1)	Page 15
TECHNICAL SPECIFICATION FOR NITROGEN INJECTION FIRE PROTECTION SYSTEM		

- b) Short time current test
- c) Dry corona and RIV test as per annexure-A
- d) Resistance test and tensile test

3.14 GALVANIZING

Galvanizing works shall conform in all respect to B.S. 729, B.S. 3083 and B.S.C.P. 2008 and to DIN 50976 whatever requires the higher quality and shall be performed by the hot dip process, unless otherwise specified. It is essential that details of steel members and assemblies which are to be hot-dip galvanized should be designed in accordance with B.S 4479.

Vent-holes and drain-holes should be provided to avoid high internal pressures and air-locks during immersion, which may cause explosions, and to ensure that molten zinc is not retained in pockets during withdrawal.

Careful cleaning of welds is necessary before welded assemblies are dipped. The welds and the surrounding metal should be cleaned separately, preferably be blast-cleaning, because the usual preliminary pickling cannot be relied on to remove the welding slag.

All defects of the steel surface including cracks, surface laminations, laps and folds shall be removed in accordance with B.S. 4360. All drilling, cutting, welding, forming and final fabrication of unit members and assemblies shall be completed, where feasible, before the structures are galvanized. The surface of the steelwork to be galvanized shall be free from paint, oil, grease and similar contaminants in accordance with DIN 55928, part 4 and DIN 50976. The weight of zinc coating per unit area has to be noted in the manufacturing documents in accordance with DIN 50976.

The minimum average coating weight shall be as specified in Table 1 of B.S. 729 or Table 2, DIN 50976, whatever requires higher quality.

Structural steel items shall be initially grit-blasted to B.S. 4232, second quality, (Sa 21/2) or by pickling in a bath and the minimum average coating weight on steel sections 5 mm thick and over shall be 610 g/m² (DFT = 85μ) .

On removal from the galvanizing bath, the resultant coating shall be smooth, continuous, free from gross surface imperfections such as bare spots, lumps, blisters and inclusions of flux, ash or dross.

Galvanized contact surfaces to be joined by high-tensile friction-grip bolts shall be roughened before assembly so that the required slip factor (defined in B.S. 3294, part 1 and B.S. 4604, part 1) is achieved. Care shall be taken to ensure that the roughening is confined to the area of the mating faces.

Bolts, nuts and washers, including general grade high-tensile friction grip bolts (referred to in B.S. 3139, and B.S.4395 part 1) shall be hot dip galvanized and subsequently centrifuged (according to B.S. 729). Nuts shall

	CLIENT – TAMILNADU GENERATION & DISTRIBUTION CORPORATION LTD.	TB-400-552-126
	CONSULTANT- TATA CONSULTING ENGINEERS LIMITED BEGALURU	Rev. 00
	PROJECT: 2X660MW UDANGUDI STPP – (STAGE-1)	Page 16
TECHNICAL SPECIFICATION FOR NITROGEN INJECTION FIRE PROTECTION SYSTEM		

be tapped up to 0.4 mm oversize after galvanizing and the threads oiled to permit the nuts to be finger-turned on the bolt for the full depth of the nut. No lubricant, applied to the projecting threads of galvanized high-tensile friction-grip bolt after the bolt has been inserted through the steelwork, must be allowed to come into contact with the mating faces of the steelwork,. A local remelting of the galvanized parts to achieve the nuts to be finger turned on the bolt is possible in accordance with DIN 50976.

Protected slings must be used for offloading and erection. Galvanized work which is to be stored at the works or on site shall be stacked so as to provide adequate ventilation to all surfaces to avoid wet storage staining (white rust).

Small areas of the galvanized coating damaged in any way shall be restored in accordance with DIN 55928, part A and DIN 50976 by:

- Cleaning the area of any weld slag rust and other impurities and by thorough wire brushing to give a metallic clean surface.
- Application of suitable number of coats of zinc-rich paint containing more than 90 % w/w of zinc in dried film. The dry film thickness shall exceed at least 50 % the thickness of the desired galvanization. In case of application of a low melting point zinc alloy repair rod, the rods shall be in accordance with DIN1707, the thickness of the alloy shall be at least as of the desired galvanization.

The restored area is not to exceed 1 % of the galvanized surface. Surface restoration of parts in contact with drinking water is not allowed and the quality of the galvanization is to be in accordance with DIN 2444.

After fixing, bolt heads, washers and nuts shall receive two coats of zinc-rich paint.

Connections between galvanized surfaces and copper, copper alloy or aluminum surfaces shall be protected by suitable preferably hydrophobe tape wrappings to the owner's approval.

3.15 DEGREE OF PROTECTION

The enclosures of the control cabinets, Junction boxes and Marshalling boxes, panels etc. to be installed as detailed here under:

The minimum requirements for panels are as follows:

- Installed out door: IP- 55
- Installed indoors in air-conditioned area: IP-32
- Installed in covered area: IP-52
- Installed indoors in non air-conditioned area where possibility of entry of water is limited: IP-41.



CLIENT – TAMILNADU GENERATION & DISTRIBUTION CORPORATION LTD.
CONSULTANT- TATA CONSULTING ENGINEERS LIMITED BEGALURU
PROJECT: 2X660MW UDANGUDI STPP – (STAGE-1)
TECHNICAL SPECIFICATION FOR NITROGEN INJECTION FIRE PROTECTION SYSTEM

TB-400-552-126

Rev. 00

Page | 17

- For LT Switchgear (AC & DC distribution Boards): IP-52.

The degree of protection shall be in accordance with IS:13947 (Part-I) / IEC-947 (Part-I) / IS 12063 / IEC 529. Type test report for degree of protection test, on each type of the box shall be submitted for approval.



CLIENT – TAMILNADU GENERATION & DISTRIBUTION CORPORATION LTD.

TB-400-552-126

CONSULTANT- TATA CONSULTING ENGINEERS LIMITED BEGALURU

Rev. 00

PROJECT: 2X660MW UDANGUDI STPP – (STAGE-1)

Page | 1

TECHNICAL SPECIFICATION FOR NITROGEN INJECTION FIRE PROTECTION SYSTEM

SECTION 4
GUARANTEED TECHNICAL PARTICULARS AND LIST OF DRAWINGS

Schedule-A **Schedule of Guaranteed Performance & other Technical Particulars of Nitrogen Injection Fire Protection System**

Schedule-B **List of Drawings**



CLIENT – TAMILNADU GENERATION & DISTRIBUTION CORPORATION LTD.

TB-400-552-126

CONSULTANT- TATA CONSULTING ENGINEERS LIMITED BEGALURU

Rev. 00

PROJECT: 2X660MW UDANGUDI STPP – (STAGE-1)

Page | 2

TECHNICAL SPECIFICATION FOR NITROGEN INJECTION FIRE PROTECTION SYSTEM

Schedule A

SCHEDULE OF GUARANTEED PERFORMANCE AND OTHER TECHNICAL PARTICULARS OF NITROGEN INJECTION FIRE PROTECTION SYSTEM FOR PREVENTION OF FIRE & EXPLOSION OF REACTOR

GUARANTEED TECHNICAL PARTICULARS N₂ INJECTION SYSTEM

(Bidder should indicate the guaranteed technical data of all equipments/materials)

1	Name of manufacturer, Address and country of origin	
2	Applicable Reference standards	
3	Details of system equipments	
	a. Fire extinguishing cubicle	
	i) Dimensions	
	ii) Weight	
	iii) Capacity of Nitrogen cylinder	
	iv) Pressure of Nitrogen filling	
	v) Minimum distance of FE cubicle from the reactor	
	vi) Method of mounting	
	vii) Whether the following items are provided in FE cubicle. If so furnish make, type & other details	
	- Contact manometer	
	- Pressure regulator	
	- Oil release unit	
	- Gas release unit	
	- Oil drain unit	
	- Pressure / limit switches	
	- No. of contacts & spare contacts(NO & NC)	
	viii) Oil drain valve	
	- Make	
	- Type	
	- Size	
	- Type of metal	
	ix) Nitrogen Injection valve	
	- Make	
	- Type	
	- Size	
	- Quantity required	
	x) Oil Drain pipe	
	- size	
	- Length	
	- Material	



CLIENT – TAMILNADU GENERATION & DISTRIBUTION CORPORATION LTD.

TB-400-552-126

CONSULTANT- TATA CONSULTING ENGINEERS LIMITED BEGALURU

Rev. 00

PROJECT: 2X660MW UDANGUDI STPP – (STAGE-1)

Page | 3

TECHNICAL SPECIFICATION FOR NITROGEN INJECTION FIRE PROTECTION SYSTEM

	xi) Nitrogen Injection pipe	
	- size	
	- Length	
	- Number of openings in the reactor tank	
	- Material	
	b) Control Box	
	i) Dimensions	
	ii) Weight	
	iii) Type & Thickness of sheet steel	
	iv) Details of components provided in the control box	
	v) Control voltage	
	vi) Method of mounting	
	vii) Whether audio and visual alarms provided?	
	c) Pre-stressed non-return valve/Pneumatically operated ball valve (Main/Backup)	
	i) Make	
	ii) Type	
	iii) Location	
	iv) Whether suitable for pipe of size 80mm dia	
	v) No. of contacts & spare contacts (NO & NC)	
	d) Fire detectors	
	i) Make	
	ii) Type	
	iii) Quantity Required	
	iv) Method of Fixing	
	v) Effective head sensing area	
	vi) Temperature recommended for effective heat sensing	
	vii) Number of contacts NO/NC	
4	Necessity and condition of re-filling	
5	Drawings/ literature enclosed with the offer	
6	Whether approved by TAC of India	
	TECHNICAL PARTICULARS OF NITROGEN INJECTION FIRE EXTINGUISHING	
1	Power Supply	
	- Control Box	
	- Fire extinguishing cubicle	
2	Fire extinction period	
	On system activation	
	On commencement of nitrogen injection	
3	Fire extinguishing cubicle suitable for 125MVA, 420kV Reactor	
	- Dimension	

864340/2022/TBG-TB ENG SR



CLIENT – TAMILNADU GENERATION & DISTRIBUTION CORPORATION LTD.

TB-400-552-126

CONSULTANT- TATA CONSULTING ENGINEERS LIMITED BEGALURU

Rev. 00

PROJECT: 2X660MW UDANGUDI STPP – (STAGE-1)

Page | 4

TECHNICAL SPECIFICATION FOR NITROGEN INJECTION FIRE PROTECTION SYSTEM

	- Weight	
	- Nitrogen cylinder capacity	
4	Control Box	
	- Dimension	
	- Weight	
5	Fire detectors	
	- Heat sensing temperature	
6	From the moment of system activation to complete cooling	
7	On commencement of Nitrogen Injection	
8	"Heat/Fire Detector" heat sensing temp	
9	Shutter valve setting for operation	
10	Other Technical Particulars	

Date :

SIGNATURE OF BIDDER

Place :

SEAL



CLIENT – TAMILNADU GENERATION & DISTRIBUTION CORPORATION LTD.

TB-400-552-126

CONSULTANT- TATA CONSULTING ENGINEERS LIMITED BEGALURU

Rev. 00

PROJECT: 2X660MW UDANGUDI STPP – (STAGE-1)

Page | 5

TECHNICAL SPECIFICATION FOR NITROGEN INJECTION FIRE PROTECTION SYSTEM

Schedule B

LIST OF MINIMUM BASIC DRAWINGS / DOCUMENTS TO BE SUBMITTED DURING DETAILED ENGINEERING

In this section, the List of system drawings & documents that are required to be generated is furnished. The numbers to be accorded against each drawing in List of drawings is also given below.

The list furnished here is tentative and additional documents may be required during detailed engineering.

1.	Details of Interconnection diagram of PNR Fire System with Spare Contacts for SCADA
2.	Details of Control Box of PNR Fire system with PNRV Indication
3.	Details of Fire Extinguishing Cubicle of PNR Fire System
4.	Details of Oil Release Unit of FE Cubicle of PNR Fire System
5.	Details of Gas Release Unit of FE Cubicle of PNR Fire System
6.	Details of Locking Pin Position for FE Cubicle of PNR Fire System
7.	Details of Valve Position with Pressure Switch in FEC of PNR Fire System
8.	Details of PNRC and Mounting Flanges for PNRV Details of PNR Fire System
9.	Details of Working of Pre-Stressed Non-Return Valve Details of PNR Fire System
10.	Details of Fire Detector of PNR Fire System
11.	Details of Plinth for Fire Extinguishing Cubicle of PNR Fire System
12.	Details of Signal Box of PNR Fire System
13.	Details of Logic Diagram for Operation of PNR Fire System
14.	Details of Control Wiring Diagram for Control Box of PNR Fire System
15.	Details of Instruction Plate for PNR Fire System
16.	Details of Oil tank for PNR Fire system
17.	Details of Oil Pit and MS Tank for PNR Fire System
18.	Guaranteed Technical Particulars
19.	Details of Pneumatic Control Diagram of PNR Fire System
20.	Bill of Material
21.	Manufacturing Quality Plan



CLIENT – TAMILNADU GENERATION & DISTRIBUTION CORPORATION LTD.

TB-400-552-126

CONSULTANT- TATA CONSULTING ENGINEERS LIMITED BEGALURU

Rev. 00

PROJECT: 2X660MW UDANGUDI STPP – (STAGE-1)

Page | 1

TECHNICAL SPECIFICATION FOR NITROGEN INJECTION FIRE PROTECTION SYSTEM

SECTION 5
SCHEDULE TO BE FILLED BY BIDDER AND ENCLOSURES TO SPECIFICATION

ENCLOSURES TO SPECIFICATION

- Schedule 1 Format of **Schedule of Deviations**
(to be submitted by Bidder at Tender Stage)
- Schedule 2 Format of **Details of contact persons (technical & commercial)**
(to be submitted by Bidder at Tender Stage)
- Schedule 3 **Enclosures to Specification**

ANNEXURE Drawings



CLIENT – TAMILNADU GENERATION & DISTRIBUTION CORPORATION LTD.

TB-400-552-126

CONSULTANT- TATA CONSULTING ENGINEERS LIMITED BEGALURU

Rev. 00

PROJECT: 2X660MW UDANGUDI STPP – (STAGE-1)

Page | 2

TECHNICAL SPECIFICATION FOR NITROGEN INJECTION FIRE PROTECTION SYSTEM

SCHEDULE – I

SCHEDULE OF TECHNICAL DEVIATION

The following are the deviations / variations / exceptions from the specification:

Section	Clause No./ Page No.	Statement of deviation/ Variations/Exceptions

- 1) Certified that the following are the only deviations from the specification (for the equipment and the systems being offered)
- 2) In case, this schedule is not submitted, it will be presumed that the equipment /material to be supplied under this contract is deemed to be in compliance with the specification.
- 3) If there is NIL deviation, even then the format to be filled as **NIL DEVIATION**
- 4) Continuation sheets of like size and format may be used as per the Bidder's Requirement and shall be annexed to this schedule.

Place

Signature of the authorized representative of Bidder

Name -----

Date

Designation -----

Company seal-----

864340/2022/TBG-TB ENG SR



CLIENT – TAMILNADU GENERATION & DISTRIBUTION CORPORATION LTD.

TB-400-552-126

CONSULTANT- TATA CONSULTING ENGINEERS LIMITED BEGALURU

Rev. 00

PROJECT: 2X660MW UDANGUDI STPP – (STAGE-1)

Page | 3

TECHNICAL SPECIFICATION FOR NITROGEN INJECTION FIRE PROTECTION SYSTEM

SCHEDULE - II**DETAILS OF CONTACT PERSON BOTH TECHNICAL AND COMMERCIAL**

Name

Address for correspondence

Phone No.

Fax No.

Email

Place

Signature of the authorized representative of Bidder

Date

Name-----

Designation-----

Company seal -----

Note:

Continuation sheets of like size and format may be used as per the Bidder's Requirement and shall be annexed to this schedule.



CLIENT – TAMILNADU GENERATION & DISTRIBUTION CORPORATION LTD.

TB-400-552-126

CONSULTANT- TATA CONSULTING ENGINEERS LIMITED BEGALURU

Rev. 00

PROJECT: 2X660MW UDANGUDI STPP – (STAGE-1)

Page | 4

TECHNICAL SPECIFICATION FOR NITROGEN INJECTION FIRE PROTECTION SYSTEM

SCHEDULE –3**ENCLOSURES TO SPECIFICATION****DRAWINGS ENCLOSED**

1. TRENCH LAYOUT FOR 400KV SWITCHYARD
DRG NO. TB-2-400-316-010 REV01
2. OUTLINE GENERAL ARRANGEMENT FOR REACTOR
DRG NO. 34690002032, 34690002033 REV02
3. FOUNDATION PLAN FOR REACTOR
DRG NO. 34690002034 REV01

FIRST ANGLE PROJECTION (ALL DIMENSIONS ARE IN MM.)

DRAWING NO. TB-2-400-316-010

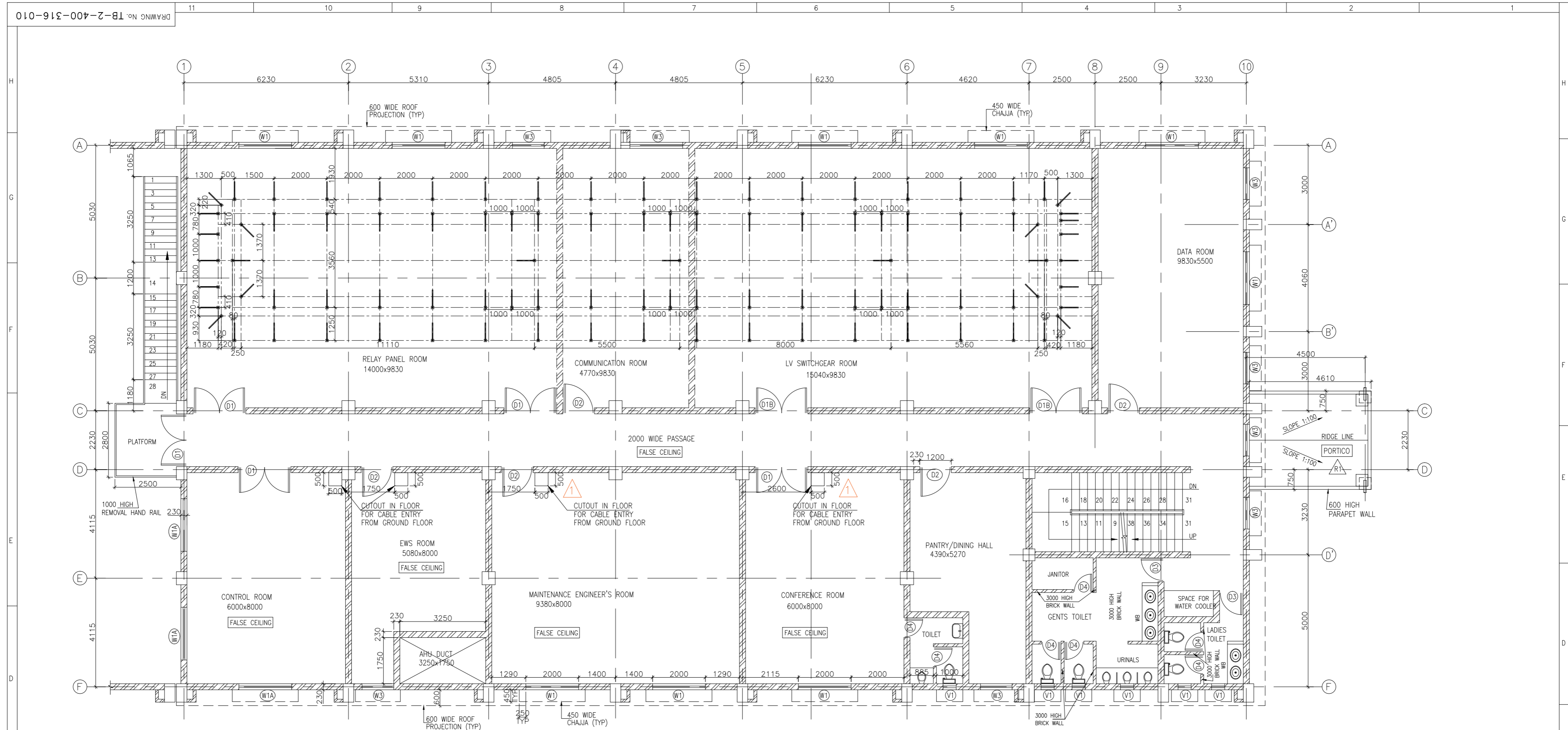

CONTROL ROOM BUILDING FIRST FLOOR PLAN AT EL(+).4.550M (UNDERHUNG CABLE SUPPORT ASSEMBLY PLAN) ⚠

NOTE:

THIS DRAWING SHOULD BE REFERRED ONLY FOR THE LOCATION OF UNDERHUNG CABLE SUPPORT ASSEMBLY IN CABLE VAULT (BELOW RELAY PANEL ROOM, COMMUNICATION ROOM, LV SWITCHGEAR ROOM FLOOR) & CUTOUT IN FLOOR FOR CABLE ENTRY IN CONTROL ROOM & EWS ROOM.

 UNDERHUNG CABLE SUPPORT ASSEMBLY

PROJECT	2X660 MW UDANGUDI SUPERCRITICAL TPS, STAGE-I
CUSTOMER	TAMILNADU GENERATION AND DISTRIBUTION CORPORATION LIMITED (TANGEDCO)
CONSULTANT	TATA CONSULTING ENGINEERS LIMITED BENGALURU
JOB NO.	BHARAT HEAVY ELECTRICALS LTD TRANSMISSION BUSINESS GROUP NOIDA
STATUS	CONTRACT
DISTRIBUTION	

REV.	DATE	ALTD	CHD	APPD	REV.	DATE	ALTD	CHD	APPD
D1	11.02.2020								

DEPT	BRN	NAME	SIGN	DATE
E	SY			11.02.2020
CHD	SRS			11.02.2020
APPD	AG			11.02.2020

REVISOR'S COMMENTS: REVISED AS PER THE COMMENTS WIDE TCE 114034-EL-V01-407 DATED 12.03.2020

TITLE: TRENCH LAYOUT FOR 400KV SWITCHYARD

SCALE: 1:300

DRAWING NO. TB-2-400-316-010

SHEET 03 OF 04 REV. 01

FIRST ANGLE PROJECTION (ALL DIMENSIONS ARE IN MM.)

DRAWING NO. TB-2-400-316-010

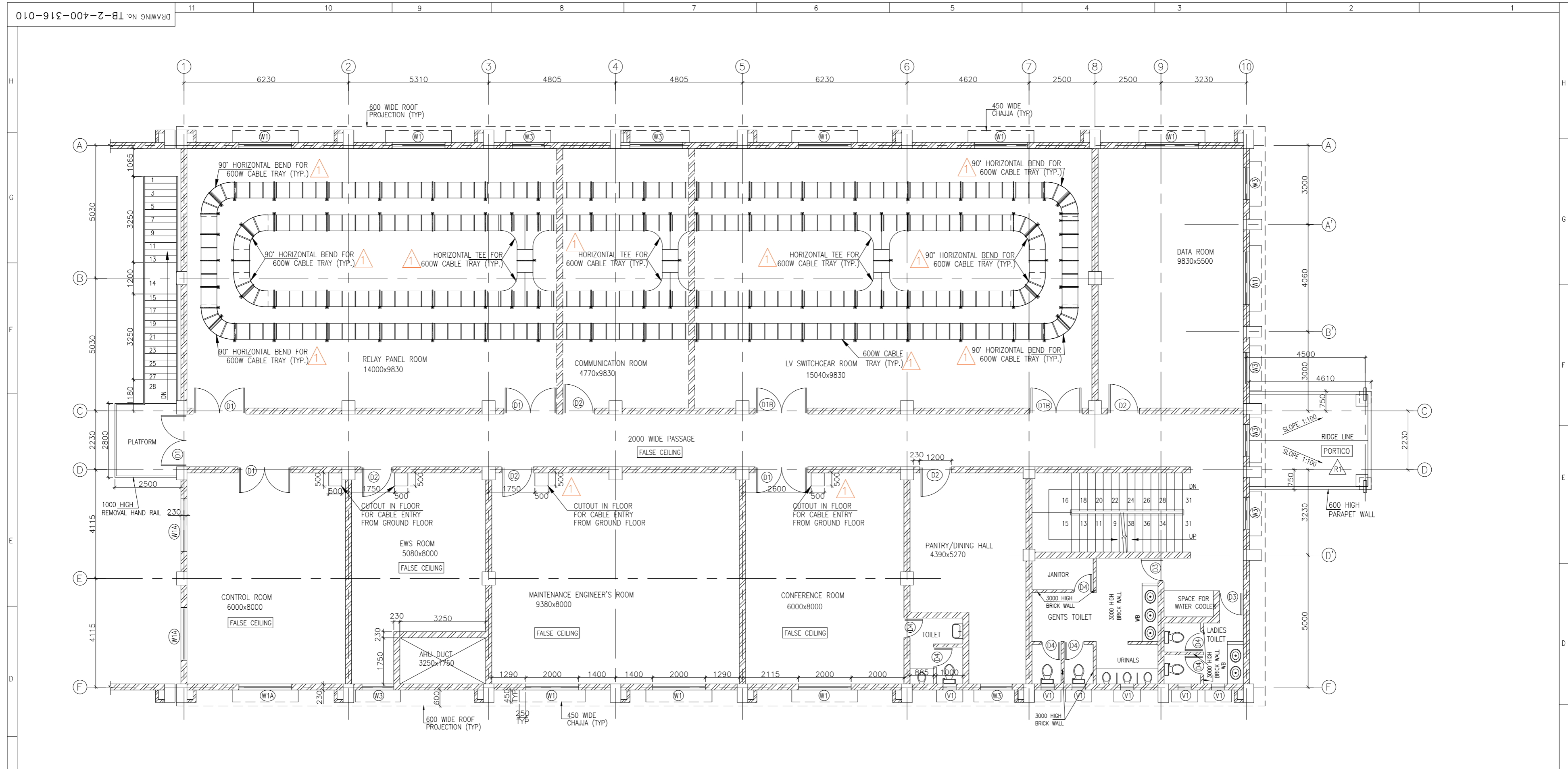

CONTROL ROOM BUILDING FIRST FLOOR PLAN AT EL(+4.550M (CABLE TRAY PLAN)

NOTE:

THIS DRAWING SHOULD BE REFERRED ONLY FOR CABLE TRAY LAYING METHOD ON UNDERHUNG CABLE SUPPORT ASSEMBLY



PROJECT	2X660 MW UDANGUDI SUPERCritical TPS, STAGE-I
CUSTOMER	TAMILNADU GENERATION AND DISTRIBUTION CORPORATION LIMITED (TANGEDCO)
CONSULTANT	TATA CONSULTING ENGINEERS LIMITED BENGALURU
	BHARAT HEAVY ELECTRICALS LTD TRANSMISSION BUSINESS GROUP NOIDA

JOB NO.	
STATUS	CONTRACT
DISTRIBUTION	

DEPT	NAME	SIGN	DATE
BRN	SY		11.02.2020
DES	SS		11.02.2020
CHK	SRS		11.02.2020
APPD	AG		11.02.2020

TITLE TRENCH LAYOUT FOR 400KV SWITCHYARD

DEPT.	SCALE 1:300	DRAWING NO.	TB-2-400-316-010
SIGN		SHEET	04 OF 04 REV. 01

REV.	DATE	ALTD	CHD	APPD	REV.	DATE	ALTD	CHD	APPD	REV.	DATE	ALTD	CHD	APPD	REV.	DATE	ALTD	CHD	APPD
D1																			

REVISAS AS PER THE COMMENTS WIDE TCE 114034-EL-V01-407 DATED 12.03.2020

COPY RIGHT AND CONFIDENTIAL The information on this document is the property of BHARAT HEAVY ELECTRICALS LIMITED it must not be used directly or indirectly in any way detrimental to the interest of the company.

REF. NO. 65002-A-517-01
REF. DRG. NO. 3 469 00 01756

THE INFORMATION ON THIS DOCUMENT IS THE PROPERTY OF BHARAT HEAVY ELECTRICALS LTD. IT MUST NOT BE USED DIRECTLY OR INDIRECTLY IN ANY WAY DETRIMENTAL TO THE INTEREST OF THE COMPANY.

NOTES:-

- WHEN REFERRING THIS DRAWING PLEASE QUOTE MVAR & W.O. NO.
- 320 DIA. TWIN BI-DIRECTIONAL ROLLERS MOUNTED AT 1676 mm RAIL GAUGE IN BOTH DIRECTION ARE PROVIDED FOR MOVEMENT OF REACTOR AT SITE AND ROLLERS ARE TO BE REMOVED BEFORE ERECTION
- PAINTING AT OUTSIDE THE REACTOR TANK & COOLER CONTROL CABINET IS AS PER SHADE NO. 631 OF IS:5.
- WIRING FROM INSTRUMENT CTS. ETC. ARE NOT SHOWN FOR CLARITY.
- FOUNDATION BOLTS ARE IN THE SCOPE OF BHEL SUPPLY.
- FOR PART LIST OF OGA REFER DRAWING NO. 3 469 00 02033.
- DIMNS. SHOWN THUS ARE OVERALL SHIPPING DIMENSIONS EXCLUSIVE OF PACKING.
- DIMENSIONS SHOWN ARE WITH REF. TO PLINTH LEVEL. PLEASE NOTE THAT PLINTH LEVEL IS 450 MM ABOVE THE GROUND LEVEL.
- FOR TANK COVER BOLTED REFER DETAIL 'B' SHT. NO. 03.

IMPORTANT NOTE :-

- THE DESIGN FEATURES SHOWN ON THIS DRAWING (GENERALLY INLINE WITH IEC : 60076-6 APPLICABLE STANDARD & AGREED CUSTOMER SPECIFICATION) MEETS THE STATUTORY, REGULATORY & SAFETY REQUIREMENTS WITH RESPECT TO EARTHING ARRANGEMENT, DANGER & OTHER LABELS, CLEARANCES IN AIR PROVISION FOR PRESSURE RELIEF DEVICE, GAS ACTUATED RELAY AND ANTI-EARTHQUAKE CLAMPING ARRANGEMENT.

MIN. AIR CLEARANCES (IN MM)		
	420 KV	145 KV
PHASE TO PHASE	4000	NA
PHASE TO EARTH	3500	1050

TABLE

SUB ASSY. MK NOS.

SUB ASSY	MK-01	MK-02	MK-03	MK-04	MK-05	MK-06	MK-07	MK-08	MK-09	MK-10	MK-11	MK-12	MK-13	MK-14	MK-15	MK-16	MK-17	MK-18	MK-19	MK-20	MK-21	MK-22	MK-23	MK-24	MK-25
QTY.	002	001	001	001	001	001	001	001	001	001	001	001	001	001	001	001	001	001	001	001	001	002	001	001	001

TATA CONSULTING ENGINEERS LIMITED
VENDOR DRAWING STATUS

CATEGORY	DESCRIPTION
<input checked="" type="checkbox"/> CAT-1	Drawing/documents approved for final distribution. BHEL will proceed with manufacturing/fabrication/construction.
<input type="checkbox"/> CAT-2	Drawing/documents cleared for manufacturing/fabrication/construction subject to incorporating the comments given. BHEL to resubmit the drawing for Approval in Category - 1. Comments will be marked on the drawing documents.
<input type="checkbox"/> CAT-3	Drawing document will be corrected as per comment and resubmitted by BHEL for further review/checking.
<input type="checkbox"/> CAT-4	Drawing document of this category are for information only and not for approval. Information furnished on the document is noted.

Note:

- It is mandatory to close documents with Code 2 & 3 to Code 1 in agreed contract period or 2 weeks, whichever is lower.
- Any design changes / modification required to be carried out in Code 4 Drawings / Documents shall be the responsibility of BHEL. BHEL to resubmit reflecting the Design Changes for information.

Approval conveyed herein neither relieves the Vendor/Contractor of his contractual obligations and his responsibilities for correctness of dimensions, materials of construction, weights, quantities, design details, assembly fits, performance requirements and conformity of supplies with the Indian Statutory Laws as may be applicable, nor does it limit the purchaser's rights under the contract.

Reviewed by S.S. Sathish Date

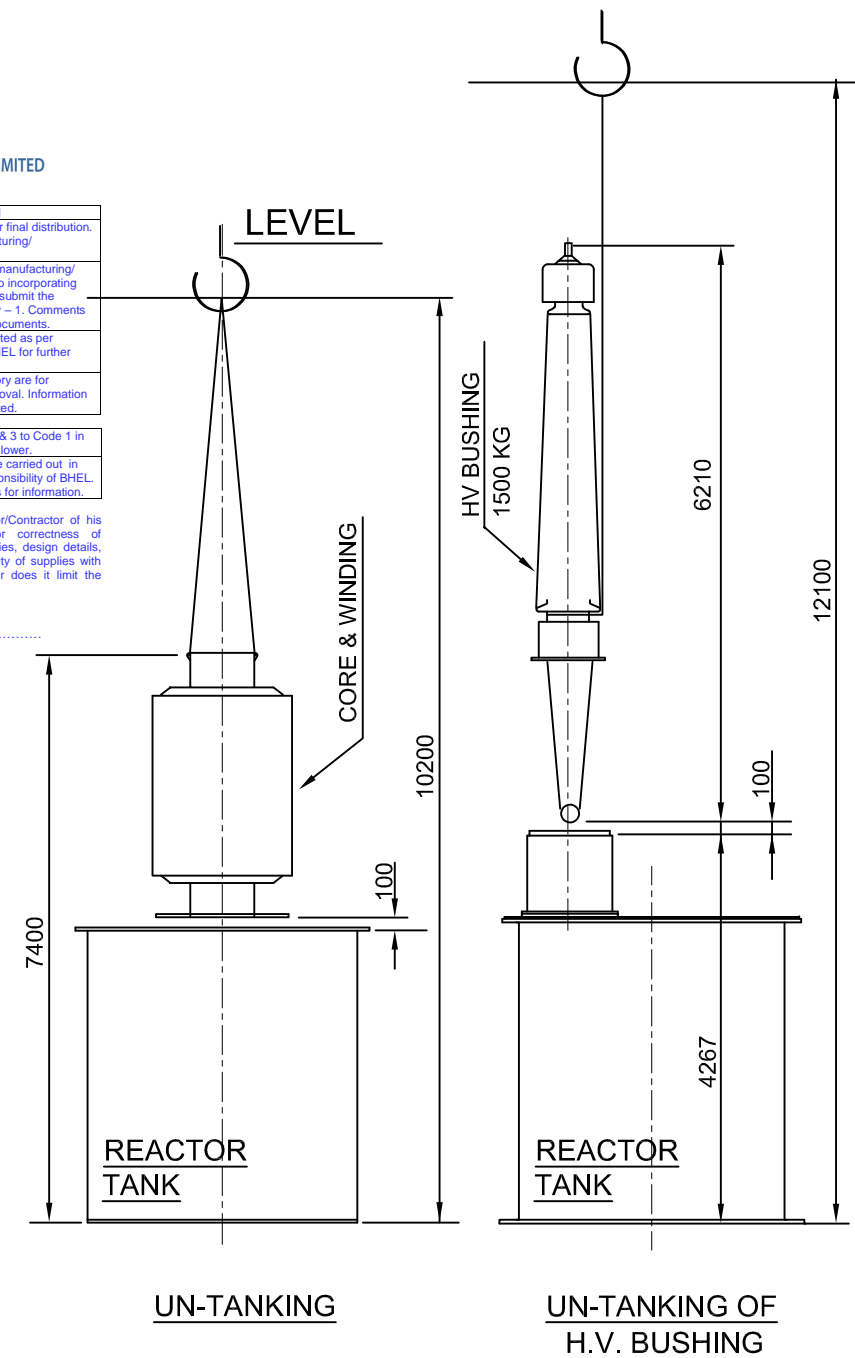

UN-TANKING

UN-TANKING OF H.V. BUSHING

INVENTORY NO. A

REV	DATE	ALT.	REV	DATE	ALT.	MKP	SD	REV	DATE	ALT.	MKP	SD
		CKD.			CKD.	KD/AJ	-SD-	01	30.07.19	CKD.	KD/AJ	-SD-
		APPD.			APPD.	KD/AJ	-SD-					

ZONE

COMMENTS INCORPORATED AS PER LETTER NO.11403A-EL-VDT-186 DTD.07/08/19

DESIGN BASIS AND SIZING (RATING) OF SHUNT REACTOR ALREADY SPECIFIED IN TECHNICAL SPECIFICATION. ENCLOSED HEREWITH.

BHEL DRAWING/DOCUMENT NO		BP-DG-435-305-0001	
ADDITIONAL INFORMATION		WO: 67023-A-517-01 STATUS OF DRAWING "PR" DISTRIBUTION OF PRINTS TRE-1, TRM-3	
PO. NO.		CE/PROJ.II/SE/C/UTPP/EE/E/LOI/D.179/2017 DTD 07.12.2017.	
TYPE OF PRODUCT		2 X 125 MVAR, 420KV, 3-PHASE, ONAN, SHUNT REACTOR.	
PROJECT		2X660MW TANGEDCO UDANGUDI THERMAL POWER PROJECT STAGE-I.	
OWNER		TAMILNADU GENERATION & DISTRIBUTION CORPORATION LTD	
OWNER'S CONSULTANT		TATA CONSULTING ENGINEERS LIMITED, BENGALURU	
NAME	SIGN	DATE	
DRN. MKP		07.01.2019	
CHD. KD/AJ		07.01.2019	
APPD. KD/AJ		07.01.2019	
TITLE/-		OUTLINE GENERAL ARRANGEMENT	
DRG. NO.		3 469 00 02032	
SHEET		01 OF 04	
REV.		02	

DRG. NO. 3 469 00 01756

THE INFORMATION ON THIS DOCUMENT IS THE PROPERTY OF BHARAT HEAVY ELECTRICALS LTD. IT MUST NOT BE USED DIRECTLY OR INDIRECTLY IN ANY WAY DETRIMENTAL TO THE INTEREST OF THE COMPANY.

REF. WO. NO. 65002-A-517-01
REF. DRG. NO. 3 469 00 01756

SIGN. DATE

INVENTORY NO.

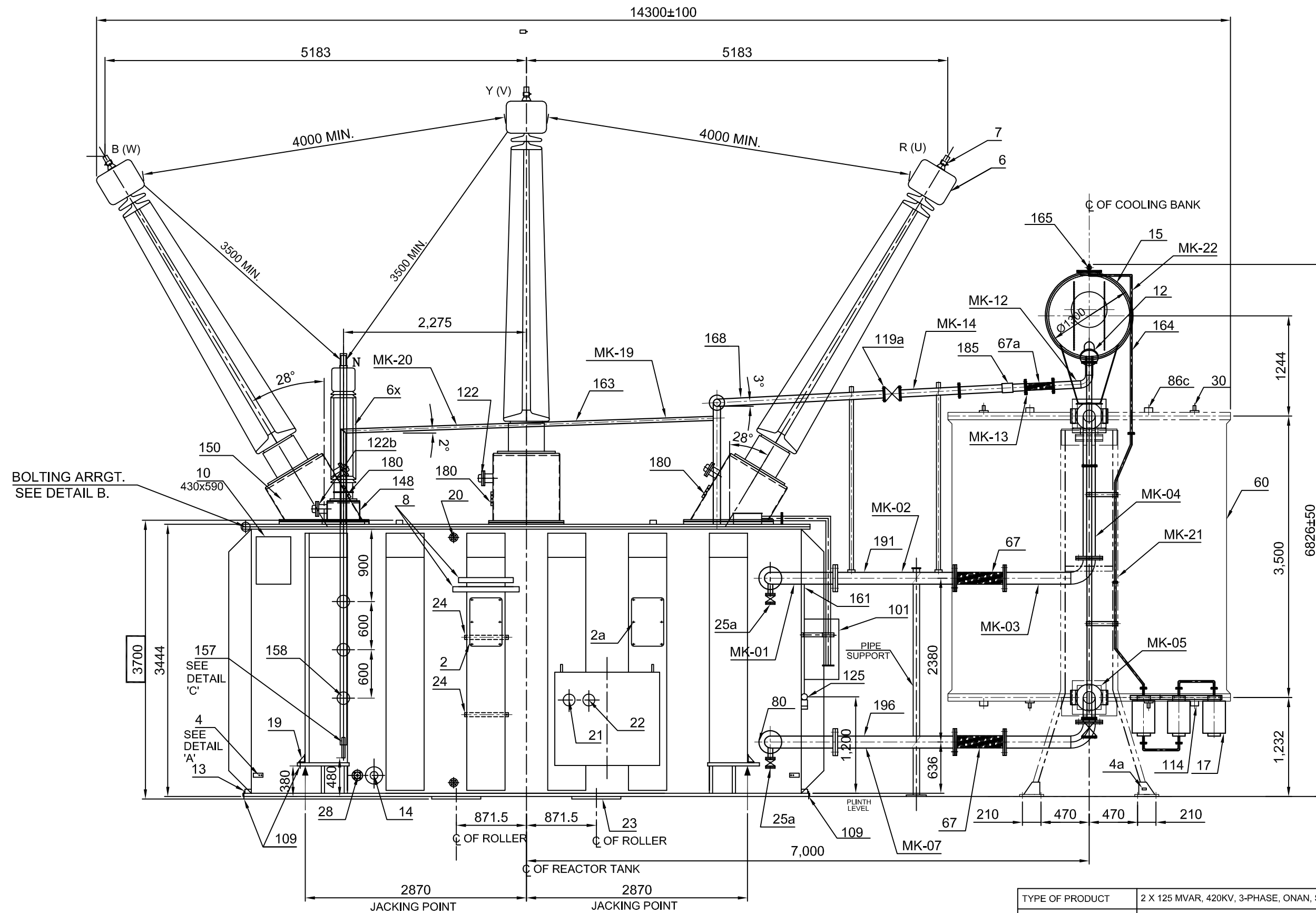

REV	DATE	ALT.	REV	DATE	ALT.	REV	DATE	ALT.	MKP	SD
		CKD.			CKD.	02	04.10.19	CKD.	KD/AJ	-SD-
		APPD.			APPD.			APPD.	KD/AJ	-SD-

BHEL DRAWING/DOCUMENT NO	BP-DG-435-305-0001
ADDITIONAL INFORMATION	WO: 67023-A-517-01 STATUS OF DRAWING "PR" DISTRIBUTION OF PRINTS TRE-1, TRM-3
PO. NO.	CE/PROJ.II/SE/C/UTPP/EE/E/LOI/D.179/2017 DTD 07.12.2017.

TYPE OF PRODUCT	2 X 125 MVAR, 420KV, 3-PHASE, ONAN, SHUNT REACTOR.		
PROJECT	2X660MW TANGEDCO UDANGUDI THERMAL POWER PROJECT STAGE-I.		
OWNER	TAMILNADU GENERATION & DISTRIBUTION CORPORATION LTD		
OWNER'S CONSULTANT	TATA CONSULTING ENGINEERS LIMITED, BENGALURU		
NAME	MKP	DATE	07.01.2019
DRN.			
CHD.	KD/AJ	DATE	07.01.2019
APPD.	KD/AJ	DATE	07.01.2019
DRG. NO.	3 469 00 02032	REV.	02
SHEET	02 OF 04		

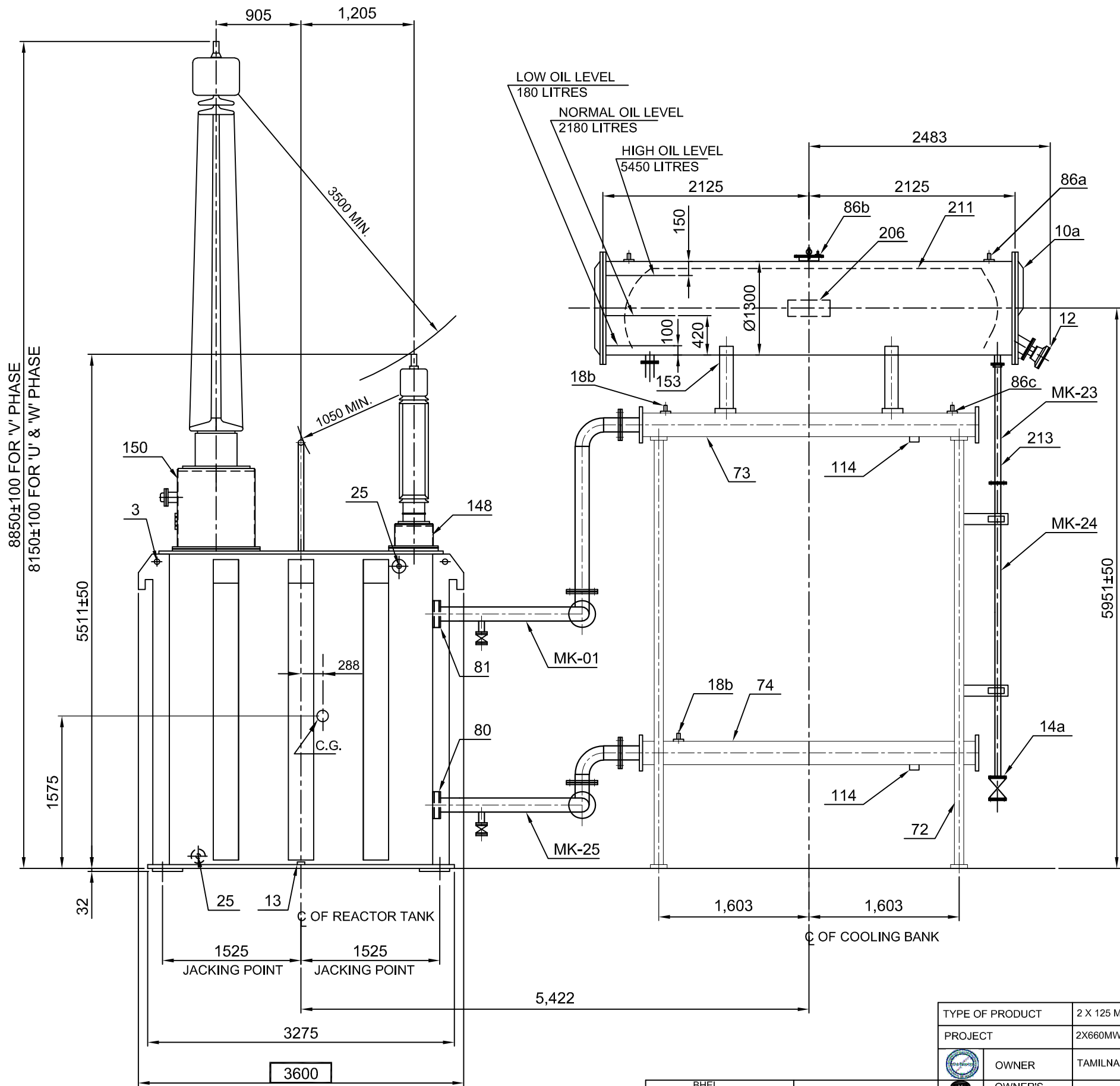

REV	DATE	ALT.	REV	DATE	ALT.	MKP	SD
02	04.10.19	CKD.	01	30.07.19	CKD.	KD/AJ	-SD-
		APPD.			APPD.	KD/AJ	-SD-

BHEL DRAWING/DOCUMENT NO	BP-DG-435-305-0001
ADDITIONAL INFORMATION	WO: 67023-A-517-01 STATUS OF DRAWING "PR" DISTRIBUTION OF PRINTS TRE-1, TRM-3
PO. NO.	CE/PROJ.II/SE/C/UTPP/EE/E/LOI/D.179/2017 DTD 07.12.2017.

TYPE OF PRODUCT	2 X 125 MVAR, 420KV, 3-PHASE, ONAN, SHUNT REACTOR.		
PROJECT	2X660MW TANGEDCO UDANGUDI THERMAL POWER PROJECT STAGE-I.		
OWNER	TAMILNADU GENERATION & DISTRIBUTION CORPORATION LTD		
OWNER'S CONSULTANT	TATA CONSULTING ENGINEERS LIMITED, BENGALURU		
NAME	MKP	DATE	07.01.2019
DRN.			
CHD.	KD/AJ	DATE	07.01.2019
APPD.	KD/AJ	DATE	07.01.2019
TITLE	OUTLINE GENERAL ARRANGEMENT (END VIEW)		
DRG. NO.	3 469 00 02032		REV. 02
SHEET	04 OF 04		

REF.WO.NO. 65002-A-517-01
REF.DRG.NO. 3 469 00 01757
SIGN DATE
INVENTORY NO.

DRG. NO. 3 469 00 02033

102

103

104

105

106

107

108

864

LIST OF DRAWING

DESCRIPTION	DRAWING NOS	QTY
OUTLINE GENERAL ARRANGEMENT(OGA)	BP-DG-435-305-0001	3 469 00 02032
OGA PART LIST	BP-DG-435-305-0002	3 469 00 02033
FOUNDATION PLAN	BP-DG-435-305-0003	3 469 00 02034
SHIPPING DIAGRAM	BP-DG-435-305-0006	3 469 00 02035
420KV, HV LINE BUSHING	BP-DG-435-305-0004	3 469 00 02036
145KV, NEUTRAL BUSHING	BP-DG-435-305-0005	3 469 00 02037
320DIA TWIN BI-DIRECTIONAL ROLLER	BP-DG-435-305-0007	3 469 00 02038
RATING AND DIAGRAM PLATE	BP-DG-435-305-0008	3 469 00 02039

APPROXIMATE WEIGHT & OIL QTY.

DESCRIPTION	WT. IN KG	OIL (L)
CORE AND WINDING	91700	
TANK & FITTINGS	23705	47040
BUSHINGS	4700	
RADIATOR BANK & DRG.	16020	7410
CONTROL CABINET	500	
TOTAL OIL	47375	54450
TOTAL WEIGHT	184000	

TATA CONSULTING ENGINEERS LIMITED
VENDOR DRAWING STATUS

CATEGORY	DESCRIPTION
<input checked="" type="checkbox"/> CAT-1	Drawing/documents approved for final distribution. BHEL will proceed with manufacturing/fabrication/construction.
<input type="checkbox"/> CAT-2	Drawing/documents cleared for manufacturing/fabrication/construction subject to incorporating the comments given. BHEL to resubmit the drawing for Approval in Category - 1. Comments will be marked on the drawing documents.
<input type="checkbox"/> CAT-3	Drawing document will be corrected as per comment and resubmitted by BHEL for further review/checking.
<input type="checkbox"/> CAT-4	Drawing document of this category are for information only and not for approval. Information furnished on the document is noted.

Note:
1. It is mandatory to close documents with Code 2 & 3 to Code 1 in agreed contract period or 2 weeks, whichever is lower.
2. Any design changes / modification required to be carried out in Code 4 Drawings / Documents shall be the responsibility of BHEL. BHEL to resubmit reflecting the Design Changes for information.

Approval conveyed herein neither relieves the Vendor/Contractor of his contractual obligations and his responsibilities for correctness of dimensions, materials of construction, weights, quantities, design details, assembly fits, performance requirements and conformity of supplies with the Indian Statutory Laws as may be applicable, nor does it limit the purchaser's rights under the contract.

Reviewed by S.S. Srinivasan Date

NOTES:-

- EACH VALVES SHALL BE PROVIDED WITH INDICATOR TO SHOW CLEAR POSITION OF THE VALVE.
- WEIGHTS & OIL QUANTITIES ARE FINAL.
- CABLE TRAY ON REACTOR TANK FOR CABLING OF INSTRUMENTS.

TABLE OF FITTINGS

ITEM NO	DESCRIPTION	QTY	ZONE
4a	EARTHING TERMINAL (20 TK X 50 X 110 LG).	2	207-B
25a	DRAIN/FILTER VALVE (50 NB GATE) FOR COOLING SYSTEM	2	205-C
30	LIFTING LUGS FOR RADIATORS	12	207-D
60	RADIATOR BANK (NO OF INDIVIDUAL UNITS = 10)	1	207-D
67	FLEXIBLE HOSE PIPE (200 NB) (TOP & BOTTOM)	2	206-C
72	"A" FRAME SUPPORTS (BEARING CAPACITY = 30 TONNES)	2	406-B
73	TOP HEADER	1	405-D
74	BOTTOM HEADER	1	405-C
86c	AIR RELEASE PLUGS (3/4"BSP)	10 NOS ON RADIATOR 2 NOS FOR TOP & BOTTOM HEADER	207-D
114	DRAIN PLUGS (3/4"BSP)	10 NOS ON RADIATOR 2 NOS FOR TOP & BOTTOM HEADER	207-B
119	ISOLATING VALVES FOR RADIATORS (80 NB BUTTERFLY)	20	307-D
161	GAS COLLECTING DEVICE PIPE (6 NB)	1 NO ON TANK COVER 2 NO ON HEADER	205-C
163	EQUALISING PIPE (50NB)	1	204-D
163a	EQUALISING PIPE (25NB) FOR TURRETS	4	303-E
191	TOP OIL PIPE 200 NB (RADIATOR BANK)	1	205-C
196	BOTTOM OIL PIPE 200 NB (RADIATOR BANK)	1	206-B

COOLING SYSTEM

CONSERVATOR AND PIPE WORK

10a	INSPECTION COVER FOR OIL CONSERVATOR (BOLTED) 20 KG	1	407-E
12	OIL GAUGE MAGNETIC TYPE WITH LOLA	1	407-E
14a	50 NB DRAIN GATE VALVE FOR OIL CONSERVATOR	1	407-C
15	OIL CONSERVATOR 1300 DIA (ATMOSEAL TYPE)	1	207-E
17	DEHYDRATING BREATHER WITH SILICAGEL (3 IN SERIES)	1	207-B
26	BUCHHOLZ RELAY (80 NB)	1	304-D
67a	FLEXIBLE HOSE PIPE (80 NB)	1	206-D
79a	LADDER WITH LOCKING DEVICE	1	306-D
86a	AIR RELEASE PLUG (3/4"BSP) FOR CONSERVATOR.	2	407-E
86b	AIR RELEASE PLUG (1/4"BSP) FOR CONSERVATOR.	1	406-E
119a	ISOLATING VALVE BUTTERFLY FOR BUCHHOLZ RELAY(80 NB) (1- GATE 1-BUTTER FLY)	2	206-D
125	GAS COLLECTING DEVICE	1	205-C
153	CONSERVATOR SUPPORTS	2	405-E
164	BREATHER PIPE (15 NB)	1	207-E
165	BREATHER ISOLATION GATE VALVE (15 NB)	1	206-E
168	CONSERVATOR PIPE (80 NB)	1	205-D
185	FLOW SENSITIVE CONSERVATOR ISOLATION VALVE	1	306-D
206	BHEL MONOGRAM	1	406-E
211	ATMOSEAL ARRANGEMENT (AIRCELL) (INSIDE THE CONSERVATOR)	1	406-E
213	CONSERVATOR DRAIN PIPE (50 NB)	1	407-D

TABLE OF FITTINGS

ITEM NO	DESCRIPTION	QTY	ZONE
2	RATING AND DIAGRAM PLATE	1	203-C
2a	DO'S & DONT'S INSTRUCTION PLATE	1	204-C
3	LIFTING LUGS (60000 KG. EACH)	4	403-D
3a	LIFTING LUGS FOR TANK COVER	6	304-E
4	EARTHING TERMINAL (SIZE 20 TK X 75 X 12 LG.) STAINLESS STEEL	4	202-B
8	NAME PLATES (ENGLISH & HINDI)	1+1	203-C
10	INSPECTION COVERS (25 Kgs EACH) (6NOS. ON TANK COVER, 1 NO. ON TANK)	7	202-D
13	DRAIN PLUGS ON TANK 1"BSP	2	202-B
14	100 NB DRAIN GATE VALVE	1	203-B
18	POCKET FOR OTI	1	304-E
18a	POCKET FOR WTI	1	305-E
18b	ORDINARY THERMOMETER WITH POCKET	1 NO ON TANK COVER 2 NO ON HEADER	2+1 304-E
18c	RTD POCKET FOR OTI	1	304-E
18d	RTD POCKET FOR WTI	1	304-E
18e	RTD POCKET FOR OTI (SPARE)	1	305-E
18f	RTD POCKET FOR WTI (SPARE)	1	304-E
19	JACKING PADS 60000 KG EACH	4	202-B
20	PROVISION FOR VALVE MTG FOR ONLINE INSULATING DRY KEEP SYSTEM	2	203-D
21	OIL TEMPERATURE INDICATOR.	1	204-B
22	WINDING TEMPERATURE INDICATOR DIAL TYPE WITH REPEATER	1	204-B
23	MOUNTING PAD FOR 320 DIA TWIN BI-DIRECTIONAL ROLLERS. ROLLERS ONLY FOR REACTOR MOVEMENT AT SITE.	4	204-B
24	MTG BRACKET FOR ONLINE INSULATING DRY KEEP SYSTEM	2	204-B
25	50 NB GATE VALVE ON TANK AND COVER (2 NOS ON TANK, 1 NO. ON COVER)	2+1	403-B
27	PRESSURE RELIEF DEVICE WITH OIL COLLECTOR ASSY.	1	305-E
28	15 NB GATE VALVE FOR OIL SAMPLING	1	203-B
34	COOLER CONTROL CABINET (TANK MOUNTED)	1	304-D
42	VALVE FOR CONNECTION TO VACUUM PUMP(100 NB BUTTERFLY)	1	305-E
79	LADDER WITH LOCKING DEVICE	1	302-E
80	BUTTERFLY VALVE (200 NB) AT INLET.	1	205-B
81	BUTTERFLY VALVE (200 NB) AT OUTLET.	1	404-C
86	AIR RELEASE PLUG 1/2"BSP.	1	304-E
109	PULLING HOLE DIA 64	8	202-B
212	COVER EARTHING OF CORE AND CORE CLAMPS.	1	305-E
6	HV LINE BUSHINGS 420 KV 1250A	3	206-E
6X	HV NEUTRAL BUSHING 145 KV 1250A	1	203-D
7	420 KV TERMINAL CONNECTOR	3	206-E
122	CONNECTION BOX FOR C T TERMINAL (HV)	3	203-D
122a	CONNECTION BOX FOR C T TERMINAL (HVN) ON COVER	4	303-E
148	NEUTRAL TURRET	1	203-D
150	HV TURRETS	3	202-D
157	NEUTRAL GROUNDING STRIP (COPPER)	1	203-B
158	POST INSULATOR	3	203-C
180	TERMINAL MARKING PLATE	4	203-D

REACTOR

BUSHING & TURRET

TYPE OF PRODUCT 2 X 125 MVAR, 420KV, 3-PHASE, ONAN, SHUNT REACTOR.

PROJECT 2X660MW TANGEDCO UDANGUDI THERMAL POWER PROJECT STAGE-I.

OWNER TAMILNADU GENERATION & DISTRIBUTION CORPORATION LTD

OWNER'S CONSULTANT TATA CONSULTING ENGINEERS LIMITED, BENGALURU

DRN. MKP 07.01.2019

STATUS OF DRAWING "PR" DRN. MKP 07.01.2019

DISTRIBUTION OF PRINTS DEPT CODE WEIGHT(kg) SCALE CHD. KDI/AJ 07.01.2019

TRE-1, TRM-3 TRE 406 ----- COMP.SCALE-1:1 DRG. NO 3 469 00 02033 REV. 02

REV	DATE	ALT.	REV	DATE	ALT.	REV	DATE	ALT.	REV	DATE	ALT.	REV	DATE	ALT.	REV	DATE	ALT.	REV	DATE	ALT.	REV	DATE	ALT.	
		CKD.			CKD.				02	04.10.19	CKD.				01	30.07.19	CKD.							
		APPD.			APPD.						APPD.													

BHEL DRAWING/DOCUMENT NO	BP-DG-435-305-0002	PO. NO.	CE/PROJ.II/SE/C/UTPP/EE/E/LOI/D.179/2017 DTD 07.12.2017.
ADDITIONAL INFORMATION	WO: 67023-A-517-01 STATUS OF DRAWING "PR" DISTRIBUTION OF PRINTS TRE-1, TRM-3	TITLE/-	OUTLINE GENERAL ARRANGEMENT (PART LIST)

