

**BANGLADESH-INDIA FRIENDSHIP POWER CORPORATION (PVT) LTD
(BIFPCL)**

**2 X 660 MW MAITREE SUPER THERMAL POWER PROJECT
AT RAMPHAL, BANGLADESH**

**TECHNICAL SPECIFICATION
FOR
WORKSHOP EQUIPMENT (PUMPS AND MISC. EQUIPMENT)**

SPECIFICATION NO.: PE-TS-421-568-A008B



BHARAT HEAVY ELECTRICALS LIMITED
(A Govt. of India Undertaking)
POWER SECTOR
PROJECT ENGINEERING MANAGEMENT
NOIDA, U.P
INDIA

788226/2022/PS-PEM-MAX

PEM-6666-0



TITLE 2X660 MW BIFPCL MAITREE

**TECHNICAL SPECIFICATION FOR
WORKSHOP EQUIPMENT
(PUMPS AND MISC. EQUIPMENT)**

SPECIFICATION NO. PE – TS – 421 - 568 – A008B

SECTION I

REV 0

SHEET OF

INDEX

SECTION	TITLE	PAGE NO.
I	Specific Technical Requirements	
I A	Scope of Enquiry	2-3
I A	Specific Technical Requirements (Mechanical)	4-21
I A	Manufacturing Quality Plan	22
I A	Sea Worthy Packing	23-88
I B	Specific Technical Requirements (Electrical)	89-109
II	Customer specification	
	General Technical Requirement	110-372
III	Documents to be Submitted by bidder	373
III A	Documents Furnished Along with Offer	374
III B	Compliance Cum Confirmation Certificate	375-376
III C	Electrical Load Data	377
III D	Pre bid clarification	378

788226/2022/PS-PEM-MAX

PEM-6666-0



TITLE 2X660 MW BIFPCL MAITREE

SPECIFICATION NO. PE – TS - 421 - 568 – A008B

**TECHNICAL SPECIFICATION FOR
WORKSHOP EQUIPMENT
(PUMPS AND MISC. EQUIPMENT)**

SECTION I

REV 0

SHEET OF

SECTION – I

SPECIFIC TECHNICAL REQUIREMENTS

SUB-SECTION IA – Specific Technical Requirement (Mechanical)

SUB-SECTION IB – Specific Technical Requirement (Electrical)

TITLE **2X660 MW BIFPCL MAITREE**TECHNICAL SPECIFICATION FOR
WORKSHOP EQUIPMENTS

SPECIFICATION NO. PE-TS-421-568-A008B

SECTION I

SUB SECTION IA

REV 00

Page 1 of 2

1.0 SCOPE OF ENQUIRY/ INTENT OF SPECIFICATION

- 1.1 This specification includes, but not limited to SUPPLY PART comprising of design (i.e. preparation and submission of drawing /documents including "As Built" drawings and O&M manuals), engineering, manufacture, fabrication, assembly, inspection / testing at vendor's & sub-vendor's works, painting, maintenance tools & tackles (as applicable), fill of lubricants & consumables, along with spares for erection, start up and commissioning as required, initial spares (as applicable), foundation bolts, nuts, lock nuts, washers, levelling pads, forwarding, sea worthy packing, shipment and delivery (at site or port, as per NIT conditions) and Supervision of Erection and Commissioning, training of Customer's O & M staff, demonstration testing at site, lodging, boarding etc, travelling expenses for specified items of Workshop Equipments package (PUMPS AND MISC. EQUIPMENT) for **2X660 MW BIFPCL MAITREE** specified as above complete with all accessories for the total scope defined as per BHEL NIT & tender technical specification, amendment & agreements till placement of order.
- 1.2 The contractor shall be responsible for providing all material, equipment & services, which are required to fulfil the intent of ensuring operability, maintainability, reliability and complete safety of the complete work covered under this specification, irrespective of whether it has been specifically listed herein or not. Omission of specific reference to any component / accessory necessary for proper performance of the equipment shall not relieve the vendor from the responsibility of providing such facilities to complete the supply of **WORKSHOP EQUIPMENTS (PUMPS AND MISC. EQUIPMENT)**.
- 1.3 It is not the intent to specify herein all the details of design and manufacture. However, the equipment shall conform in all respects to high standards of design, engineering and workmanship and shall be capable of performing the required duties in a manner acceptable to purchaser who will interpret the meaning of drawings and specifications and shall be entitled to reject any work or material which in his judgement is not in full accordance herewith.
- 1.4 The extent of supply under the contract includes all items shown in the drawings, notwithstanding the fact that such items may have been omitted from the specification or schedules. Similarly, the extent of supply also includes all items mentioned in the specification and /or schedules, notwithstanding the fact that such items may have been omitted in the drawing.
- 1.5 The general term and conditions, instructions to tenderer and other attachment referred to elsewhere are made part of the tender specification. The equipment materials and works covered by this specification is subject to compliance to all attachments referred to in the specification. The bidder shall be responsible for and governed by all requirements stipulated herein.
- 1.6 While all efforts have been made to make the specification requirement complete & unambiguous, it shall be bidders' responsibility to ask for missing information, ensure completeness of specification, to bring out any contradictory / conflicting requirement in different sections of the specification and within a section itself to the notice of BHEL and to



TITLE **2X660 MW BIFPCL MAITREE**
 TECHNICAL SPECIFICATION FOR
WORKSHOP EQUIPMENTS

SPECIFICATION NO. PE-TS-421-568-A008B

SECTION I

SUB SECTION IA

REV 00

Page 2 of 2

seek any clarification on specification requirement in the format enclosed under Vol-III of the specification. In absence of any such clarifications, in case of any contradictory requirement, the more stringent requirement as per interpretation of Purchaser/Customer shall prevail and shall be complied by the bidder without any commercial implication on account of the same. Further in case of any missing information in the specification not brought out by the prospective bidders as part of pre-bid clarification, the same shall be furnished by Purchaser/ Customer as and when brought to their notice either by the bidder or by purchaser/ customer themselves. However, such requirements shall be binding on the successful bidder without any commercial & delivery implication.

- 1.7 The bidder's offer shall not carry any sections like clarification, interpretations and /or assumptions.
- 1.8 Deviations, if any, should be very clearly brought out clause by clause in the enclosed deviation schedule along with cost of withdrawal; otherwise, it will be presumed that the bidder's offer is strictly in line with NIT specification. If no cost of withdrawal is given against the deviation, it will be presumed that deviation can be withdrawn without any cost to BHEL/its customer.
- 1.9 In the event of any conflict between the requirements of two clauses of this specification documents or requirements of different codes and standards specified, more stringent requirement as per the interpretation of the owner shall apply.
- 1.10 In case all above requirements are not complied with, the offer may be considered as incomplete and would become liable for rejection.
- 1.11 Unless specified otherwise, all through the specification, the word contractor shall have same meaning as successful bidder /vendor and Customer/ Purchaser/Employer will mean BHEL and /or customer including their consultant as interpreted by BHEL in the relevant context. For details refer the relevant clause in GCC.
- 1.12 Apart from specific design requirement for Workshop Equipment, design of various systems/ Sub-systems and all equipment will also strictly meet the stipulations of Part B0 of Customer's Technical Specification.



TITLE **2X660 MW BIFPCL MAITREE**
SPECIFIC TECHNICAL REQUIREMENTS FOR
WORKSHOP EQUIPMENT

SPECIFICATION NO. PE – TS – 421 - 568 – A008B

SECTION I

SUB SECTION IA

REV 0

SHEET 1 OF 18

1.0 **SYSTEM DESCRIPTION AND SCOPE OF WORK**

Various types of equipment / machines which are included in bidder's scope of work and required for the maintenance and repair workshop of the power station equipment are given under: -

A- **PUMPS FOR WORKSHOP EQUIPMENT: -**

S. No.	EQUIPMENT NAME	TECHANCIAL DETAIL	ACCESSORIES	QTY.
1.0	Diesel engine pump set	<p>Diesel engine pump, capacity-150 m³/h, Head-15 MWC, Suction and Discharge Hose Pipe- 10 m and 20 m respectively, Liquid to be handled-Turbid Water</p> <p>Material of Construction of Pump: -</p> <p>a) Casing & Suction Bell- Cast Iron GG 20</p> <p>b) Impeller-Cast Iron GG25</p> <p>c) Shaft- 17-4PH Stainless Steel</p> <p>d) Shaft Sleeve- Heat Treated 416 SS</p> <p>e) Wearing Rings- Cast Iron</p> <p>f) Guide Rail Pipe and Lifting Hook & Chain- SS-316</p> <p>g) Base Plate-MS</p> <p>Diesel Engine specification</p> <p>a) Type-4 Stroke diesel engine</p> <p>b) Fuel- Diesel</p> <p>c) Cooling System- Air Cooler Heat Exchanger/ Coolant Shell and Tube Heat Exchanger</p> <p>d) Power output- As per pump requirement</p> <p>e) Lubrication System- As per Manufacturer Std.</p> <p>f) Rated Speed -As per pump requirement</p> <p>g) Air Handling- Air cleaner</p> <p>h) Exhaust Emission- As per Bangladesh latest emission norms at the time of dispatch.</p> <p>i) MOC of CAM SHAFT and CRANK SHAFT- Forged Steel, Piston- Aluminum Steel</p>		6



TITLE **2X660 MW BIFPCL MAITREE**
SPECIFIC TECHNICAL REQUIREMENTS FOR
WORKSHOP EQUIPMENT

SPECIFICATION NO. PE – TS – 421 - 568 – A008B

SECTION I

SUB SECTION IA

REV 0

SHEET 2 OF 18

2.0	Jet washing pump portable	Capacity from 20 Bar up to 150 Bar, flow rate min 400 LPH		3
-----	---------------------------	---	--	---

B- MISC. WORKSHOP EQUIPMENT: -

S. N.	Equipment name	Offered Equipment	ACCESSORIES	QTY.
1.0	Stationary valve grinding machine	<ul style="list-style-type: none"> • Portable Valve Lapping and Grinding Machine for sealing faces in valves for nominal diameter 50 to 400 mm. The machine should be 3-phase electric motor driven with motor protection switch and other standard accessories. • Portable Flange Facing (Single Point Milling) Machine suitable for valves and flanges of diameter 50 to 400 mm. The machine should be 3-phase electric motor driven with motor protection switch and other standard accessories. • A tilting table of size approx 600 mm X 600 mm for fixing valves (nominal dia 50 to 400 mm) for machining with provision for tilting of min. upto 12^o along with marked up scales for measurement of angle of tilt. This table suitably mounted on work bench of suitable working height, length and width. 	Standard Accessories for proper functioning of machine as per manufacturer standard.	2 nos. of each equipment



TITLE **2X660 MW BIFPCL MAITREE**
SPECIFIC TECHNICAL REQUIREMENTS FOR
WORKSHOP EQUIPMENT



SPECIFICATION NO. PE – TS – 421 - 568 – A008B

SECTION I

SUB SECTION IA

REV 0

SHEET 3 OF 18

S. N.	Equipment name	Offered Equipment	ACCESSORIES	QTY.
2.0	Combined folding, bending and Embossing Machine	<p>Combined folding & bending machine shall be- with supporting frame, for hand operation, working length approx. 1000 mm, max. sheet metal thickness 1.5 mm, shaft diameter approx. 65 mm with back gears and standard accessories.</p> <p>Embossing Machine shall be Hand operated indicative photograph of embossing machine is below.</p> 	Standard Accessories for proper functioning of machine as per manufacturer standard.	1 Set
3.0	Flanging machine	<p>Max. working depth 240 mm, for sheet steel up to 1.5 mm with standard accessories use in tin smith workshop.</p> <p>Reference photograph is shown.</p> 	Standard Accessories for proper functioning of machine as per manufacturer standard.	1



TITLE **2X660 MW BIFPCL MAITREE**
SPECIFIC TECHNICAL REQUIREMENTS FOR
WORKSHOP EQUIPMENT

SPECIFICATION NO. PE – TS – 421 - 568 – A008B

SECTION I

SUB SECTION IA

REV 0

SHEET 4 OF 18

S. N.	Equipment name	Offered Equipment	ACCESSORIES	QTY.
4.0	Mobile floodlighting sets	 <p>Mobile floodlighting sets for outdoor repair works, ready for operation.</p> <p>a. No of Lamps – 4 Nos. of 400 Watt each.</p> <p>b. Mast Height -9 Mtr. Approx.</p> <p>c. Type of Lamp- Metal Halide.</p> <p>d. Powered through Diesel Engine.</p> <p>e. Maximum Towing speed 30 Km/Hr.</p> <p>f. Continuous running hours -50 Hr Approx.</p> <p>Reference photograph is shown.</p> <p>Packing of items shall be in container, Container shall be in vendor scope and shall be supplied on non-returnable basis.</p>	Standard Accessories for proper functioning of machine as per manufacturer standard.	4

PAINTING SCHEDULE

At Works: -

Surface Preparation: - Degreasing and surface preparation to SA 2 1/2.

Prime coat: - One (1) coat of zinc epoxy primer. Dry film thickness 80 microns per coat.

Intermediate coat: - One (1) layer Epoxy high solid, Dry film thickness 160 micron.

Finish coat: - Application of one coat of polyurethane. Dry film thickness 50 microns per coat.

Total system: Dry film thickness 290 microns.

Final shade of paint shall be as per manufacturer's standard only.

Vendor standard painting schedule shall also be acceptable if it is suitable for coastal environment.

NOTES: -

- 1) Maintenance tools and tackles as required for the various machines, commissioning spares for various machines as applicable, first fill lubricant /coolant for each equipment is included in Bidder's scope of work.
- 2) Machines shall be supplied with the manufacturer's standard accessories & other accessories as indicated above. Bidder shall submit list of all other special accessories in their bid & furnish item wise price in the price bid.

2.0 The followings shall also be included in bidder's scope of work: -

- 2.1 Required numbers of machines in new / unused condition along with standard accessories and special accessories as listed above in the specification.



TITLE 2X660 MW BIFPCL MAITREE <u>SPECIFIC TECHNICAL REQUIREMENTS FOR</u> <u>WORKSHOP EQUIPMENT</u>	SPECIFICATION NO. PE – TS – 421 - 568 – A008B		
	SECTION	I	
	SUB SECTION	IA	
	REV	0	
	SHEET	5	OF 18

- 2.2 First fill of lubricants, oil, coolants etc. for all machines.
- 2.3 Painting of equipment shall be done by the bidder before despatch as per the attached painting schedule. Bidder shall also supply adequate quantity of loose touch up paint along with the equipment so that damage in transition, if any, can be taken care.
- 2.4 Base plates, Support plates, anchor bolts, foundation bolts and nuts, lifting lugs, eye bolts etc. if any. All commissioning spares shall be included in the scope of work of each equipment / item.
- 2.5 Terminal points for electrical shall be the power supply terminals in respective machines and power cable glands and lugs shall be in bidder's scope.
- 2.6 The electrical equipment supplied as a part of machine shall include isolating switch for power supply isolation incorporating mechanical safety as required.
- 2.7 Commissioning spares shall be included in the scope of work of the bidder.
- 2.8 A complete unused new set of special purpose service / maintenance tools & tackles shall be supplied with each machine. The tools shall be supplied in steel tool box & shall be of the best quality & specially protected against rusting in tropical climate.
- 2.9 Five (5) metres of power cable (spare) shall be supplied along with each machine / item. Portable / Mobile Equipment shall be supplied with power cable (20-30 meter, preferably wrapped in drum) and plug as applicable.
- 2.10 Supervision of Erection and Commissioning (for applicable equipment / machines).
- 2.11 Any other works not covered above but required for the safe operation of the machines.
- 3.0 **CODES & STANDARD**

The machines covered under the scope of work shall be new, of streamlined construction, rugged and vibration free in line with the international standard and practices.

Chinese Standards and codes are not allowed. In case bidder proposes any IS code, it shall be verified by reputed institutions like IIT that the proposed code is equivalent or superior to the codes mentioned above. Comparison report shall be established and provided to BHEL/Owner for information. Such report shall highlight the main items of the code, including material composition, material properties, design clauses and others as required. Report shall identify deviations of both codes and give justification for this deviation. No cost or time implication will be acceptable for any delay on account of non-acceptance by customer of justification for deviation by bidder. In case equivalence is not established, bidder has to provide material as per specified codes only.

In case International standards like IEC or ISO is available, this shall be followed.

The bidder shall ensure that design will consider material properties as per approved code.

List of codes & standards already accepted by customer in addition to the above specified codes standards:

SA / IS 2062 for structural steel material



TITLE	2X660 MW BIFPCL MAITREE			SPECIFICATION NO. PE – TS – 421 - 568 – A008B
	<u>SPECIFIC TECHNICAL REQUIREMENTS FOR</u>			SECTION I
	<u>WORKSHOP EQUIPMENT</u>			SUB SECTION IA
	REV	0		
	SHEET	6	OF	18

All Design requirement as indicated in Part B0 of Fichtner specification and as applicable to specified Workshop Equipment to be complied.

4.0 **SERVICES BY CUSTOMER**

- 4.1 Draining arrangement of liquid coolant from source to the nearest drain.
- 4.2 Construction of Workshop building.
- 4.3 Pipe trench & cable trenches, doors / windows, rolling shutter, ramp and glass partition wall, if any.
- 4.4 Cable termination.
- 4.5 EOT crane.
- 4.6 Erection and commissioning of workshop machines.

5.0 **DOCUMENTS AND DATA REQUIRED TO BE SUBMITTED AFTER PLACEMENT OF LOI**

Following drawings and documents shall be submitted to BHEL for approval after the placement of LOI:-

- a) General arrangement drawing indicating overall dimensions, total weights, foundation details and bill of material for all types of machines including requirement of withdrawal space along with technical data sheet.
- b) Manual calculation for selection of machines including authentic supporting literature (e.g. handbook / standards).
- c) Manual calculation for requirement of air / water quantity and pressure including authentic supporting literature (e.g. handbook / standards).
- d) Quality assurance plan being followed for all items of each type of machine starting from raw material to final product including routine and type test being conducted at works.
- e) Write - up on working principle and special safety features envisaged for each type of machines along with Erection and Commissioning Procedure.
- f) O & M manual.

NOTE:-

- 1) The list of drawings and documents to be submitted after placement of order shall be forwarded to the successful bidder after award of contract.
- 2) Only manual calculation with authentic supporting literature shall be furnished (e.g. Hand book / standards / codes).
- 3) Drawings and documents not covered above but required to check safety of machines / system shall be submitted during detailed engineering stage without any commercial implication.

6.0 **General requirement**



TITLE **2X660 MW BIFPCL MAITREE**
SPECIFIC TECHNICAL REQUIREMENTS FOR
WORKSHOP EQUIPMENT

SPECIFICATION NO. PE – TS – 421 - 568 – A008B

SECTION I

SUB SECTION IA

REV 0

SHEET 7 OF 18

01. All the drawings shall be prepared in Auto Cad - 2010 version or higher and required number of hardcopies and soft copies of all the drawings, documents, O & M and spare parts manuals shall be furnished to BHEL during detailed engineering stage as per Annexure – III enclosed with the NIT specification.
02. Inspection checklist / quality plan and recommended field quality plan for each machine and submitted to BHEL for approval after placement of order and any changes required by BHEL / CUSTOMER for the same shall be incorporated and adhered by the bidder without any commercial implications.
03. BHEL will require 21 days time to offer their comments on the drawings and documents being submitted by the bidder from the date of receipt.
04. All drawings including general arrangement, civil foundation drawing shall be furnished to BHEL during detailed engineering stage and shall include BOQ / BOM in tabular form indicating all major components including bought out items, standard as well as optional accessories which are covered under the bidder's scope of supply and their quantity, material of construction indicating its applicable code / standard, weight, make.
05. All drawings of each machine including general arrangement and foundation drawings shall be furnished to BHEL during detailed engineering stage and shall include / indicate the following details for clarity w.r.t. inspection, construction, erection and maintenance etc.: -
 - a) All drawings and documents shall bear BHEL's title block and drawing / document number. However, BHEL's drawing / document numbering scheme shall be furnished to the successful bidder after the placement of L.O.I.
 - b) All drawings shall indicate the list of all reference drawings including general arrangement and foundation drawings.
 - c) All drawings shall include / show plan, elevation, side view, cross - section, skin section, blow - up view and all major self-manufactured, bought out items, standard as well as optional accessories which are covered under the bidder's scope of supply shall be labelled and included in BOQ / BOM in tabular form.
 - d) Specification / schedule of coolant / oil for oil cooler / lubricant / paint indicating atleast 3 trade name shall be made as a part of general arrangement drawing of each machine.
 - e) Extreme location of various items / assembly due to movement shall be shown in dotted lines indicating the dimensions of the same from the extreme point of idle location.
 - f) Location of motor (s), control panel along with dimensions shall be shown in the drawing.
 - g) Space required for the door opening of panel shall be shown in dotted lines with dimensions in all the general arrangement drawing.
 - h) Details of job feeding and withdrawal direction with arrow and its required space shall be shown in dotted lines with dimensions from some reference point like edge / centre of the machine.



TITLE	2X660 MW BIFPCL MAITREE		SPECIFICATION NO. PE – TS – 421 - 568 – A008B
	<u>SPECIFIC TECHNICAL REQUIREMENTS FOR</u>		SECTION I
	<u>WORKSHOP EQUIPMENT</u>		SUB SECTION IA
	REV	0	
	SHEET	8 OF	18

- i) Location of operator and required space for his movement shall be shown in the general arrangement drawing in dotted lines with dimensions from some reference point like edge / centre of the machine.
- j) Requirement of withdrawal space for maintenance, if any, shall be shown in the general arrangement drawing in dotted lines with dimensions from the reference point like edge / centre of the machine.
- k) Recommended clearance / maintenance space around the machine shall be shown in the general arrangement drawing in dotted lines with dimensions from the reference point like edge / centre of the machine.
- l) Mounting details of each machine indicating size and required number of holes and the distances between them shall be indicated in the general arrangement drawing.
- m) Distance between the mounting holes and distances of the same from some reference point like centre line of machine / edge of the machine to ensure correct construction of foundation and to know maximum space required for civil foundation and mechanical equipment.
- n) Technical parameters of the machine shall be furnished (gearbox details, job rpm, vibration limit, noise level at a distance of 1.0 metre at a level of 1.5 metres above ground, V - belt details, details of pulley, details of all motors and hydraulics, whether the machine will be dispatched / delivered in the assembled condition or dismantled condition indicating the weight as the case may be, recommended capacity of E.O.T Crane, weight of heaviest (single) part / component of the machine, weight of machine along with accessories, job and total weight shall be furnished separately etc.) in all the general arrangement drawing and those shall be indicated in the drawing with dimensions to the extent possible. Details of electrical panel, wiring diagram, other relevant electrical and C&I detail as applicable shall also be furnished.
- o) Details of cable entry for each machine shall be shown in all the 3 views (plan, elevation and side view).
- p) Hardness and type / method of hardening of various parts of each machine shall be indicated in the general arrangement drawing.
06. Manual Calculation for motor (s) sizing shall be furnished to BHEL during detailed engineering stage for approval along with the copy of authentic supporting literature e.g. Hand book, National / international Standards etc in line with the technical specification.
07. O & M manual shall be furnished to BHEL for approval during detailed engineering stage along with the general arrangement drawing.
08. Drawing / data sheet of all accessories shall be furnished to BHEL for approval during detailed engineering stage indicating brief specification.
09. Operational write-up along with safety features and interlock / control details of each machine shall be furnished to BHEL separately for approval during detailed engineering stage.



TITLE 2X660 MW BIFPCL MAITREE <u>SPECIFIC TECHNICAL REQUIREMENTS FOR</u> <u>WORKSHOP EQUIPMENT</u>	SPECIFICATION NO. PE – TS – 421 - 568 – A008B		
	SECTION	I	
	SUB SECTION	IA	
	REV	0	
	SHEET	9	OF 18

10. Separate drawing for lifting arrangement of machine during erection shall be furnished to BHEL for approval indicating dimensions and details of lifting lugs, rope etc.
11. Civil foundation drawing of each machine shall be furnished to BHEL for approval during detailed engineering stage showing / including the followings: -
 - a) Scope of work by BHEL and vendor which shall be indicated with different legend or in the form of note.
 - b) Weight of moving parts, its frequency and its height from floor shall be furnished.
 - c) Recommended location of cable trench for feeding cable to machine shall be furnished along with the details of cable entry.
 - d) Civil loads per bolt (static and dynamic) shall be furnished in tabular form considering weight of maximum size of job and worst cutting force.
12. Separate general arrangement drawing of drive arrangement shall be furnished to BHEL for approval during detailed engineering stage.
13. Characteristic curve of motor shall be furnished to BHEL for approval during detailed engineering stage showing torque, speed, current & voltage.
14. Design of machines shall be such that no cooling water / air from external source shall be required for cooling of any part of machine. Necessary cooling arrangement, as required, shall be provided by the bidder in their machines.
15. Bidder has to depute competent designer (s) of each machine at BHEL's office during detailed engineering stage to discuss drawings and other technical documents as and when required by BHEL. However, minimum 7 days notice shall be served for the same.
16. Make of various bought items shall be as indicated in the NIT specification. Bidder will seek approval from BHEL / Customer during detailed engineering stage for those items which are not appearing in the list but required for the machine /equipment.
17. Painting specification and schedule shall be provided by the bidder for each machine as indicated in the NIT specification. However, painting specification of those items / equipments which are not covered in the specification, bidder to prepare the painting specification (suitable for sea atmosphere) for each item / machine / equipment and will be submitted to BHEL / CUSTOMER for approval after placement of order and any changes required by BHEL / CUSTOMER for the same shall be incorporated and adhered by the bidder without any commercial implications. Bidder to include adequate quantity of loose touch up paint for each item / equipment / machine which is required to be supplied along with the item / equipment / machine to take care damage during transit and price for the same, if any, shall be taken care in the price bid.
18. Noise level for each machine at a horizontal distance of 1.0 metre from the edge of the machine and at a height of 1.5 metres from the ground shall be limited to 85 dba and the same shall be shown during the demonstration test.
19. Inspection checklist / MQP etc. shall be prepared by the bidder and will be submitted to BHEL / CUSTOMER for approval after placement of order and any changes required by



TITLE	2X660 MW BIFPCL MAITREE			SPECIFICATION NO. PE – TS – 421 - 568 – A008B
	<u>SPECIFIC TECHNICAL REQUIREMENTS FOR</u>			SECTION I
	<u>WORKSHOP EQUIPMENT</u>			SUB SECTION IA
	REV	0		
	SHEET	10	OF	18

BHEL / CUSTOMER for the same shall be incorporated and adhered by the bidder without any commercial implications. Necessary instruments / job material (steel plate / bar etc.) as required for the testing / inspection of machines shall be arranged by the bidder and shall also be included in bidder's scope of work.

20. All foundation nuts, bolts, lock nuts, washers etc. as required for fixing the machine with foundation shall be included in bidder's scope of work for each machine and the same shall be supplied along with the machine/equipment and **price for the same shall be taken care in the price bid, if any.**
21. All necessary guards, devices, tools & other means that will effectively protect all personnel from any accidental or injury that may occur while machine is in running condition shall be in bidder's scope of work and shall be provided and shown in the drawings to be submitted during detail engineering stage.
22. Offered machines shall be suitable for the electrical conditions like voltages, frequencies, variations etc. as indicated in project information of NIT specification.
23. BHEL, will provide one (1) no. feeder per machine. Bidder to note & confirm that they will distribute the power requirement of various motors at their end only for this feeder.
24. List of maintenance tools / hand tools & tackles in terms of numbers only indicating sizes / ratings etc. in annexure form for each machine shall be submitted during detail engineering stage and the same shall be included in bidder's scope of work. Maintenance tools and tackles shall be supplied along with the tool box(es) and **price for the same shall be taken care in the final price bid, if any.**
25. List of commissioning spares in terms of numbers only indicating sizes / ratings etc. in annexure form for each machine shall be submitted during detail engineering stage and same shall be included in bidder's scope of work and shall be supplied along with the machine. **Price for the same shall be taken care in the final price bid, if any.**
26. Necessary earthing studs / facilities for the machine and cables within the machine shall be provided by the bidder.
27. All machines shall be provided with DOL starter for electric motor driven equipment.
28. Bidder to furnish the Signed & stamped copy of quality plan for motors attached with the NIT specification during detail engineering stage.
29. Cable Glands shall be double compression tinned brass type and the cable glands shall be supplied as a part of each machine and **price for the same shall be taken care in the price bid, if any.**
30. All cable lugs shall be heavy-duty tin-plated crimping type the cable lugs shall be supplied as a part of each machine and **price for the same shall be taken care in the price bid, if any.**
31. All technical parameters of LV motors shall comply data sheet –A for LV motors.



TITLE	2X660 MW BIFPCL MAITREE		SPECIFICATION NO. PE – TS – 421 - 568 – A008B
	<u>SPECIFIC TECHNICAL REQUIREMENTS FOR</u>		SECTION I
	<u>WORKSHOP EQUIPMENT</u>		SUB SECTION IA
	REV	0	
	SHEET	11 OF	18

32. Filled up motor data sheet of motor (for each motor) and filled up electrical load data format (enclosed with the NIT specification) for each machine shall be submitted during detail engineering stage.
33. All the hand wheels shall be polished / Nickel - Chrome plated as applicable.
34. List of standard accessories (which will be supplied free of cost along with the machine) in terms of numbers only for each machine shall be indicated in the offer and included in bidder's scope of work. **Price for the same shall be taken care in the price bid, if any.**
35. Bidder to indicate the material of construction of major parts of the machines indicating relevant International Standard no.

7.0 **SPECIFIC REQUIREMENTS REGARDING ERECTION / TESTING & COMMISSIONING**

Field quality plan for all machines shall be prepared by the bidder during detailed engineering stage as per agreed schedule and the same shall be approved by BHEL to facilitate handling of equipment, erection & commissioning.

8.0 **INSPECTION, TESTING AND CODES**

- 8.1 The machine offered shall conform to the latest relevant international Codes / Standards, their electrical drives shall conform to the latest International Electricity Rules and shall comply for the currently applicable statutory regulations and safety codes for the locality where the equipment shall be installed.
- 8.2 Each machine before despatch shall be shop assembled & tested for its performance in the presence of purchaser's representative. Vendor to ensure the proper quality checks during manufacturing & assembly of machine, including identification, co-relation & verification of material test certificates for critical components like gears, shafts, spindles, sleeves etc. and radiographic tests for welds and ultrasonic tests on forging/castings to ensure defects free components and furnish test procedure, reports & test certificates on shop tests.
- 9.0 Drawing / document distribution schedule is attached in the NIT specification. Bidder shall follow the same during detail engineering stage.



TITLE **2X660 MW BIFPCL MAITREE**
SPECIFIC TECHNICAL REQUIREMENTS FOR
WORKSHOP EQUIPMENT

SPECIFICATION NO. PE – TS – 421 - 568 – A008B

SECTION I

SUB SECTION IA

REV 0

SHEET 12 OF 18

ANNEXURE - I**MAKES OF SUB VENDORS ITEMS OF WORKSHOP EQUIPMENT**

S. NO.	ITEM	SUPPLIERS	PLACE	REMARKS
1.	BEARINGS	SKF	-	
		FAG	-	
		TATA	-	
		NBC	-	
2.	V- BELT	FENNER	-	
		DUNLOP	-	
3.	HYDRAULIC POWER PACK	VICKERS-PERRY	-	
		REXROTH	-	
4.	PVC POWER CABLES	APAR INDUSTRIES LTD.	MUMBAI	
		CORDS CABLE INDUSTRIES LTD.	NEW DELHI	
		DIAMOND POWER INFRASTRUCTURE LTD	VADODARA	
		GOYOLENE FIBRES (INDIA) PVT.LTD	MUMBAI	
		GOVIND CABLE INDUSTRIES	KOLKATA	
		GUPTA POWER INFRASTRUCTURE LIMITED	BHUBNESWAR	
		HAVELLS INDIA LIMITED	NOIDA	
		KEI INDUSTRIES LTD.	NEW DELHI	
		KRISHNA ELECTRICAL INDUSTRIES LTD	GWALIOR	
		KEC INTERNATIONAL LIMITED	MUMBAI	
		MANSFIELD CABLES COMPANY LTD.	NOIDA	
		NICCO CORPORATION LTD.	KOLKATA	
		PARAMOUNT COMMUNICATIONS LTD.	NEW DELHI	
		POLYCAB WIRES PVT. LTD.	MUMBAI	
		RADIANT CORPORATION PRIVATE LIMITED	HYDERABAD	
		RAVIN CABLES LIMITED	MUMBAI	
		SUYOG ELECTRICALS LTD.	VADODARA	
SRRAM CABLES PVT. LTD.	NEW DELHI			
SCOT INNOVATION WIRES AND CABLES PVT. LTD.	SOLAN			
SAM CABLES & CONDUCTORS (P) LTD	UDHAM SINGH NAGAR			
THERMO CABLES LTD	HYDERABAD			
5.	PVC CONTROL CABLES	ADVANCE CABLE TECHNOLOGIES (P) LTD	BANGALORE	
		APAR INDUSTRIES LTD., CMI LTD	MUMBAI	



TITLE **2X660 MW BIFPCL MAITREE**
SPECIFIC TECHNICAL REQUIREMENTS FOR
WORKSHOP EQUIPMENT

SPECIFICATION NO. PE – TS – 421 - 568 – A008B

SECTION I

SUB SECTION IA

REV 0

SHEET 13 OF 18

S. NO.	ITEM	SUPPLIERS	PLACE	REMARKS
		CMI LIMITED	FARIDABAD	
		CORDS CABLE INDUSTRIES LTD	NEW DELHI	
		CRYSTAL CABLE INDUSTRIES LTD	KOLKATA	
		DELTON CABLES LTD	NEW DELHI	
		DIAMOND POWER INFRASTRUCTURE LTD	VADODARA	
		ELKAY TELELINKS LTD	NEW DELHI	
		GEMSCAB INDUSTRIES LTD	NEW DELHI	
		GOVIND CABLE INDUSTRIES	KOLKATA	
		GUPTA POWER INFRASTRUCTURE LIMITED	BHUBNESWAR	
		HAVELLS INDIA LIMITED	NOIDA	
		INCOM CABLES (P) LTD	NEW DELHI	
		KEI INDUSTRIES LTD	NEW DELHI	
		KRISHNA ELECTRICAL INDUSTRIES LTD	GWALIOR	
		KEC INTERNATIONAL LIMITED	MUMBAI	
		MANSFIELD CABLES COMPANY LTD	NOIDA	
		NICCO CORPORATION LTD	KOLKATA	
		PARAMOUNT COMMUNICATIONS LTD	NEW DELHI	
		POLYCAB WIRES PVT. LTD	MUMBAI	
		RAVIN CABLES LIMITED	MUMBAI	
		SUYOG ELECTRICALS LTD	VADODARA	
		SPECIAL CABLES PVT. LTD	NEW DELHI	
		SCOT INNOVATION WIRES AND CABLES PVT. LTD	SOLAN	
		SAM CABLES & CONDUCTORS (P) LTD	UDHAM SINGH NAGAR	
		SPM POWER & TELECOM PVT. LTD	HYDERABAD	
		TORRENT CABLES LTD	AHMEDABAD	
		THERMO CABLES LTD	HYDERABAD	
		TIRUPATI PLASTOMATICS PVT. LTD	JAIPUR	
		UNIVERSAL CABLES LTD	SATNA	
6.	XLPE POWER CABLES	APAR INDUSTRIES LTD	MUMBAI	
		CORDS CABLE INDUSTRIES LTD	NEW DELHI	
		CRYSTAL CABLE INDUSTRIES LTD	KOLKATA	
		DIAMOND POWER INFRASTRUCTURE LTD	VADODARA	
		GEMSCAB INDUSTRIES LTD	NEW DELHI	



TITLE **2X660 MW BIFPCL MAITREE**
SPECIFIC TECHNICAL REQUIREMENTS FOR
WORKSHOP EQUIPMENT

SPECIFICATION NO. PE – TS – 421 - 568 – A008B

SECTION I

SUB SECTION IA

REV 0

SHEET 14 OF 18

S. NO.	ITEM	SUPPLIERS	PLACE	REMARKS
		GOVIND CABLE INDUSTRIES	KOLKATA	
		GUPTA POWER INFRASTRUCTURE LIMITED	BHUBNESWAR	
		HAVELLS INDIA LIMITED	NOIDA	
		KEI INDUSTRIES LTD	NEW DELHI	
		KRISHNA ELECTRICAL INDUSTRIES LTD	GWALIOR	
		KEC INTERNATIONAL LIMITED	MUMBAI	
		MANSFIELD CABLES COMPANY LTD	NOIDA	
		PARAMOUNT COMMUNICATIONS LTD	NEW DELHI	
		POLYCAB WIRES PVT. LTD	MUMBAI	
		RAVIN CABLES LIMITED	MUMBAI	
		SUYOG ELECTRICALS LTD	VADODARA	
		SPECIAL CABLES PVT. LTD	NEW DELHI	
		SCOT INNOVATION WIRES AND CABLES PVT. LTD	SOLAN	
		SRIRAM CABLES PVT. LTD	NEW DELHI	
		TORRENT CABLES LTD	AHMEDABAD	
		THERMO CABLES LTD	HYDERABAD	
		TIRUPATI PLASTOMATICS PVT. LTD	JAIPUR	
7.	XLPE CONTROL CABLES	APAR INDUSTRIES LTD	MUMBAI	
		CABLE CORPORATION OF INDIA LTD	MUMBAI	
		CRYSTAL CABLE INDUSTRIES LTD	KOLKATA	
		DIAMOND POWER INFRASTRUCTURE LTD	VADODARA	
		GEMSCAB INDUSTRIES LTD	NEW DELHI	
		HAVELLS INDIA LIMITED	NOIDA	
		KEI INDUSTRIES LTD	NEW DELHI	
		KRISHNA ELECTRICAL INDUSTRIES LTD	GWALIOR	
		KEC INTERNATIONAL LIMITED	MUMBAI	
		PARAMOUNT COMMUNICATIONS LTD	NEW DELHI	
		POLYCAB WIRES PVT. LTD	MUMBAI	
		RADIANT CORPORATION PRIVATE LIMITED	HYDERABAD	
		RAVIN CABLES LIMITED	MUMBAI	
		SUYOG ELECTRICALS LTD	VADODARA	
		SRIRAM CABLES PVT. LTD	NEW DELHI	
		TORRENT CABLES LTD	AHMEDABAD	
		UNIVERSAL CABLES LTD	SATNA	



TITLE **2X660 MW BIFPCL MAITREE**
SPECIFIC TECHNICAL REQUIREMENTS FOR
WORKSHOP EQUIPMENT

SPECIFICATION NO. PE – TS – 421 - 568 – A008B

SECTION I

SUB SECTION IA

REV 0

SHEET 15 OF 18

S. NO.	ITEM	SUPPLIERS	PLACE	REMARKS
8.	PUMP FOR COOLANT	PHULSONS	BANGLORE	
		RAJPURA / RAJAMANE INDUSTRIES PVT. LTD.		
9.	LT MOTORS	SIEMENS	-	
		NGEF (up to 15KW)	-	
		CROMPTON	-	
		KIRLOSKAR	-	
		BHARAT BIJLI	-	
		ALSTOM	-	
		ABB	-	
10.	PAINT	ASIAN PAINTS (I) LTD.	-	
		BERGER PAINTS INDIA LTD	-	
		GOODLASS NEROLAC	-	
		JENSON & NICHOLSON (I) LTD	-	
		CDC CARBOLINE (I) LTD.	-	
		SHALIMAR PAINTS LTD.	-	
		ADDISON PAINTS LTD	-	
		GRAND POLYCOAT	-	
		BOMBAY PAINTS	-	
		HEMPLE PAINTS (SINGAPORE)	-	
		JOTUN PAINTS	-	

NOTE:

- THE SUB VENDOR LIST ABOVE IS INDICATIVE ONLY AND IS SUBJECT TO BHEL AND CUSTOMER APPROVAL DURING DETAILED ENGINEERING STAGE WITHOUT ANY COMMERCIAL & DELIVERY IMPLICATION TO BHEL.

BIDDER TO PROPOSE SUB VENDOR WITH CREDENTIALS WITHIN 2 WEEKS OF PLACEMENT OF LOI. THEREAFTER NO REQUEST FOR ADDITIONAL SUB-VENDOR SHALL BE ENTERTAINED.
- BIDDER SHALL PROCURE ALL ITEMS INCLUDING PLATES, STRUCTURAL, FLANGES; COUNTER FLANGES ETC. FROM APPROVED SUB VENDOR ONLY.
- THE INSPECTION CATEGORY WILL BE INTIMATED AFTER AWARD OF CONTRACT BY BHEL/CUSTOMER. HOWEVER, THE SAME WILL BE ADHERED BY THE BIDDER WITHOUT ANY COMMERCIAL AND DELIVERY IMPLICATION TO BHEL/ CUSTOMER.
- BIDDER TO ENSURE THAT ALL ITEMS CONFORM TO INTERNATIONAL STANDARD. BIDDER MAY SUGGEST SUB VENDORS TO MEET THE INTERNATIONAL STANDARDS AS APPLICABLE FOR THE MANUFACTURING AND SUPPLY OF THE RESPECTIVE COMPONENT DURING DETAIL ENGINEERING WHICH SHALL BE SUBJECT TO CUSTOMER APPROVAL.**



TITLE	2X660 MW BIFPCL MAITREE		SPECIFICATION NO. PE – TS – 421 - 568 – A008B
	SPECIFIC TECHNICAL REQUIREMENTS FOR		SECTION I
	WORKSHOP EQUIPMENT		SUB SECTION IA
	REV	0	
	SHEET	16 OF	18

ANNEXURE-II

DRAWINGS, DATA / DOCUMENTS TO BE FURNISHED BY THE SUCCESSFUL BIDDER

The successful bidder shall submit the following drawings / documents for each machine / equipment (as applicable), during detail engineering for approval /information:

LIST OF PRIMARY DRAWING / DOCUMENTS:

Sl. No.	BHEL DRG.NO	DRAWING TITLE	REMARKS	SUBMISSION SCHEDULE - WEEK NUMBER FROM DATE OF LOI
1.	PE-V0-421-568-A001	Inspection Check List / Manufacturing Quality Plan of machine/equipment	APPROVAL	3
2.	PE-V0-421-568-A002	Data sheet of machine/equipment with detailed BOM WORKSHOP EQUIPMENT	APPROVAL	3
3.	PE-V0-421-568-A003	GA, Foundation Detail (as required) of Machine / Equipment	APPROVAL	3

List of Secondary dwg. /doc for each machine / equipment (as applicable) after approval of basic dwg. / doc:

Sl. No.	BHEL DRG.NO	DRAWING TITLE	REMARKS	SUBMISSION SCHEDULE - WEEK NUMBER FROM DATE OF LOI
3.	PE-V0-421-568-A004	O & M Manual for EQUIPMENT	INFORMATION	2 weeks after approval of primary dwg/doc.
4.	PE-V0-421-568-A005	Sea Worthy Packing for Equipment	INFORMATION	2 weeks after approval of primary dwg/doc.
5.	PE-V0-421-568-A006	Erection Procedure for WORKSHOP EQUIPMENT	INFORMATION	2 weeks after approval of primary dwg/doc.

- The above drawing list is tentative and shall be finalized with the successful bidder after placement of order. Every repeat submission within Ten (10) days. Response time by BHEL within 18 days after receiving of drawing. Supplier is required to submit hardcopies of O&M manual after 30 days of release of MDCC.
- Drawings shall be prepared in Auto-Cad latest edition. Required no. of hard and soft copies (editable) of the drawings shall be furnished as per requirement specified elsewhere in the specification.
- All the drawings and documents including general arrangement drawing, data sheet, calculation etc. to be furnished to the customer during detailed engineering stage shall include / indicate the following details for clarity w.r.t. Inspection, construction, erection and maintenance etc.: -



TITLE **2X660 MW BIFPCL MAITREE**
SPECIFIC TECHNICAL REQUIREMENTS FOR
WORKSHOP EQUIPMENT

SPECIFICATION NO. PE – TS – 421 - 568 – A008B

SECTION I

SUB SECTION IA

REV 0

SHEET 17 OF 18

- a) All drawings and documents shall indicate the list of all reference drawings including general arrangement.
- b) All drawings shall include / show plan, elevation, side view, cross - section, skin section, blow - up view; all major self-manufactured and bought out items shall be labeled and included in BOQ / BOM in tabular form.
- c) Painting schedule shall also be made as a part of general arrangement drawing of each equipment / items indicating at least 3 trade names.



TITLE **2X660 MW BIFPCL MAITREE**
SPECIFIC TECHNICAL REQUIREMENTS FOR
WORKSHOP EQUIPMENT

SPECIFICATION NO. PE – TS – 421 - 568 – A008B

SECTION I

SUB SECTION IA

REV 0

SHEET 18 OF 18

ANNEXURE - III

Drawings / documents distribution schedule

S.N.	DESCRIPTION	CUSTOMER / CONSULTANT	BHEL / Customer SITE	PEM (ENGINEERING)
1)	Drawings / documents during approval stage	10	Nil	6 – hard copy and 1 – soft copy (CD)
2)	Finally approved drawings / documents	10	9	6 – hard copy and 6 - softcopy (CD)
3)	As built drawings / documents	10	9	6 – hard copy and 6 - softcopy (CD)
4)	Approved erection / installation manual	10	9	6 – hard copy and 6 - softcopy (CD)
5)	Approved O & M manuals	10	9	6 – hard copy and 6 - softcopy (CD)

Note: The above requirement is minimum. However, exact quantities of drawings / documents requirement shall be informed to the successful bidder during detailed engineering stage for which no commercial implication shall be entertained by BHEL.

All drawings & documents shall be prepared in Autocad and submitted for review / approval in soft copies also. Catalogues shall be scanned for soft copy.

Note:- Manually prepared drawings are not acceptable.

Soft copy in CD Rom and Reproducible Tracings of all drawings / documents shall be submitted along with Final / As-Built submission.

“Bidder to note that BHEL reserve the right for drg/doc submission through web based Document Management System. Bidder would be provided access to the DMS for drg/doc approval and adequate training for the same. Detailed methodology would be finalized during the kick-off meeting. Bidder to ensure following at their end.

- Internet explorer version – Minimum Internet Explorer 7
- Internet speed – 2 mbps (Minimum preferred)
- Pop ups from our external DMS IP (124.124.36.198) should not be blocked
- Vendor’s Internal proxy setting should not block DMS application’s link (<http://124.124.36.198/wrenchwebaccess/login.aspx>)”

SL. NO	COMPONENT & OPERATIONS	CHARACTERISTICS	CLASS	TYPE OF CHECK	QUANTUM OF CHECK		REFERENCE DOCUMENT	ACCEPTANCE NORMS	FORMAT OF RECORD		AGENCY			REMARKS
					M	C/B				D*	M	C	B	
1.	2.	3.	4.	5.	6.		7.	8.	9.	D*	** 10.			11.

		LEGEND: * RECORDS, IDENTIFIED WITH "TICK" (√) SHALL BE ESSENTIALLY INCLUDED BY SUPPLIER IN QA DOCUMENTATION. ** M: MANUFACTURER/SUB-SUPPLIER C: MAIN SUPPLIER, B: BIFPCL P: PERFORM W: WITNESS AND V: VERIFICATION. AS APPROPRIATE, CHP: BIFPCL SHALL IDENTIFY IN COLUMN "B" AS 'W'		DOC. NO.:	REV..... CAT.....	
MANUFACTURER/ SUB-SUPPLIER	MAIN-SUPPLIER		FOR BIFPCL USE		REVIEWED BY	APPROVED BY
SIGNATURE						





TITLE

**TECHNICAL SPECIFICATION
FOR WORKSHOP EQUIPMENT
2X660 MW BIFPCL KHULNA**

SPECIFICATION NO. PE – TS - 421 - 568 – A008B

SECTION I

SUB SECTION IA

REV 0

SHEET OF

SEA WORTHY PACKING & CONTAINERS FOR TRANSIT AND STORAGE

Packing and Marking

All the equipment shall be suitably protected, coated, covered or boxed and crated to prevent damage or deterioration during transit, handling and storage at site till the time of erection. Packing shall be done to ensure protection against the coastal environment prevailing at site.

All equipment's shall be delivered in containers suitable for the transit as well as for storage at site.

The Contractor shall be responsible for all loss or damage during transportation, handling and storage due to improper packing.

Packing and shipping instructions shall be as detailed below.

PACKING & SHIPPING INSTRUCTIONS

1. All units/ sub vendors/ contractors are strictly advised to comply with packing instructions mentioned in contract documents (GCC clause 65: Packaging & Section V, FTS, Clause B0.3.5 Packaging and transportation).
2. Special Packing Instructions & Inspection Prior to Dispatch
 - Packing (tare) shall be part of the Equipment cost and shall not be subject to return. The packing should ensure integrity and cohesiveness of each delivery batch of Equipment during transportation. In case of Equipment assemblies and unit's delivery in the packing of glass, plastics or paper the specification of packing with the **material and weight characteristics are to be indicated.**
 - All packages to be wrapped in transparent polythene inside the crates for effective weather proofing
 - Each package should have the following inscriptions and signs stenciled with an indelible ink legibly and clearly:
 - Destination:
 - Package number: BHEL/MTR/BD/XXX/YYYYY where XXX stands for Unit abbreviation e.g. RPT
 - YYYYY stands for package no.
 - Gross and Net weight
 - Dimensions
 - Lifting places
 - Handling marks and the following delivery marking:

"BANGLADESH-INDIA FRIENDSHIP POWER COMPANY (Pvt.) LIMITED
2X660 MW MAITREE SUPER THERMAL POWER PROJECT
BANGLADESH"

EPC CONTRACTOR: BHARAT HEAVY ELECTROCALS LIMITED, INDIA
 - Completeness of Contents of each packing case: Concerned CQA/Unit QC/Third Party Inspection Agency shall verify the completeness of contents of each package w.r.t packing list both in terms of quality and quantity before authorising dispatch of the consignment.
 - Packing commensurate with international standards and accepted norms will be ensured by CQA/ Unit QC/Third Party Inspection Agency. Packing has to be **SEA WORTHY** and secure.
 - As far as possible, the packing has to be rectangular in shape for optimum space utilization in the ship and economize on shipping costs. Projections on packages are prohibited.
 - The packing list has to be checked and certified by the Inspection agency (ies) with due signatures.
 - Packages are envisaged to be transported on Vessels/ Barges through Sea/ river water ways and will require transshipment and intermediate storage. Hence, if deemed necessary by respective unit, packages may be enclosed in suitable GI sheets on all sides to prevent any damage during transportation/ transshipment/ storage.
 - No loose items / Gunny bags packing shall be allowed for shipment.
 - Proper pallets and crates are to be used for packing of Oil drums and Structures.

- Routing of Packing Lists: Packing list is an extremely important document, which forms a part of export documentation in connection with the processing of customs formalities. Packing List has to be generated by units/Unit vendors and sent to MEPG and ROD (both at the same time), two weeks in advance, for processing and obtaining shipping bills' clearances and avoiding octroi payment through 'N' form at Mumbai.
- Advance intimation to ROD & MEPG: All supplying units/vendors will give at least 15 days advance intimation to ROD & MEPG along with package details before actual dispatches to arrange for storage/shipping arrangements by ROD and customs invoicing by 10. Information must be sent to consolidate the details and arrange for shipments in time.
- Excise Attestation at Works: To avoid opening of big cases for examination by customs at port of shipment, the supplying unit may arrange to get the packing cases sealed by local excise authorities/ self-certification and the relevant invoices and packing lists to be endorsed from Superintendent, Central Excise. For this purpose, Units should send the packing lists to MEPG at least 2 weeks in advance to enable prepare Shipping Invoices for furnishing to the units for requisite attestation and sending to ROD through fastest means for a smoother and faster customs clearance. Also Units to provide "specification of packing with the indication of the number of cargo packages, type of packing and weight of packing in English" along with the packing list.
- If deemed necessary by respective unit, provision of Inspection Windows of size 6" x 4" (glass perplex) for customs examination for all packages (above 1.5 x 1.5 x 1.5 cu m) involving panels of any kind shall be provided by Unit/Vendors . Care would be taken to ensure that all packages are properly sealed to avoid ingress of moisture, rodents etc. Packing slip folders to be attached in each box.
- Drawings for Heavy Weight/ODC consignment: Any package/item weighing above 20000 kgs and/or size greater than 2.5 X 2.5 X 4 m. detailed engineering documents (at least 4 sets) for all items of the above category will be furnished by respective units to issue shipment enquiries in a proper manner. The drawing has to include centre of gravity of the item clearly (Units to identify such items and notify MEPG as soon as the engineering documents are released).
- Lifting Beams: All heavy lifts for which safe handling is essential at the port of dispatch shall be accompanied by lifting beam on non-returnable basis.
- "Marking for Safe Handling: To ensure safe handling, packing case shall be marked to show the following:
 - ✓ Upright position.
 - ✓ Sling position and Centre of Gravity position.
 - ✓ Storage category.
 - ✓ Fragile components (to be marked properly with a clear warning for safe handling).

EXPORT PACKING

(PACKING INSTRUCTIONS FOR GENERAL COMPONENTS / ASSEMBLIES / EQUIPMENT)

1 GENERAL

This standard lays down packing instructions for export packing of components/assemblies/equipment to be dispatched against Customer's contracts, for which there are no special instructions issued by the Engineering Departments. For Seaworthy Packing refer standard AA0490004 wherever applicable.

The components/assemblies need to be packed suitably to avoid physical damage & corrosion during transit for storage. For specific applications, the concerned engineering department shall issue a product standard. Reference of this standard, must appear in the Shipping list/Packing List.

2 SCOPE

This procedure gives minimum guidelines for export packing to be complied with for packing of components/assemblies/equipment. This packing shall be suitable for different handling operations and for the adverse conditions during transportation and during indoor / outdoor storage for periods more than one year.

3 WOOD SPECIFICATION FOR PACKING:

- a) The wood shall conform to specification AA51401.

In addition to the above the following has to be met:

The standard requires the use of debarked wood in the construction of compliant wood packaging material. Debarked wood is defined in the ISPM 15

- b) Ply Wood planks as per specification IS:303 Gr. "MR" Type A,B are used for the sides, top & bottom of the packing cases.
- c) Ply Wood of marine grade as per IS:710 for packing of control equipment and for support batten pinewood to be used as per specification AA51401.

4 TYPE OF PACKING:

The following types of packing have been standardized for packing of general components/assemblies.

- 'OP' - Open Type
- 'PP' - Partially Packed
- 'CP' - Crate Packing - Components/Equipment requiring physical protection
- 'CQ' - Case Packing - Small medium Components/ Assemblies/ Equipment which require corrosion & physical protection
- 'CR' - Case Packing - Electrical Components/Assemblies which require special packing viz. Water Proof, Shock Proof, etc.

DESCRIPTION OF TYPES OF PACKING

The various types of packing, as standardized above, are described below.

4.1 'OP' - Open Type

In case, of components which are not affected by water & dust & do not require special protection &, are generally not machined, shall be sent as open packages. However these components may be sent in crates, wherever necessary.

4.2 PP' - Partially Packed

Components which need special protection, at selected portions only, shall be dispatched partially packed. Machined surfaces should not be allowed to come directly in contact with the wood. Such surfaces after application of TRP should be protected with Multi-layered cross laminated plastic film to AA51420.

4.3 'CP' - Crate Packing – General

Assemblies/Components which need only physical protection from the point of view of handling shall be dispatched duly packed in crates.

4.4 'CQ' - Case Packing - Machined Components/Assemblies/Equipment

- a) Small & Medium sized components/assemblies/equipment due to size/weight & to avoid handling, and pilferage, problems shall be packed in Case/Containers.
- b) Wherever required adequate quantity of silica gel to AA55619 or VCI Powder/ Tablets, packed in thin muslin cloth cotton bags shall be suitably placed.
- c) Small machines/components of less weight shall be provided with suitable cushioning. Wood Wool/Expanded Polyethylene Foam Sheet, if used, shall be sandwiched between polyethylene sheets and sealed.
- d) The components inside the case shall be entirely covered with Multi-layered cross laminated plastic film to AA51420, where-ever required.

4.5 'CR' - Case Packing - Electrical & Electronic Components/Assemblies

Delicate components likely to be damaged e.g. Gauges, Instruments etc. are to be wrapped in waxed paper or polyethylene air bubble film and packed in cartons.

- a) Adequate quantity of Silica gel to AA55619 packed in cotton bags, of 100 grams each are to be suitably placed in the cartons. The cartons shall be entirely covered with Multi-layered cross laminated plastic film to AA51420, before being packed in the cases.
- b) VCI Powder/Tablets can be used as an alternative to Silica Gel to AA55619.
- c) Empty space in the cartons shall be filled with small chips of Expanded Polystyrene (Thermocole), Wood Wool etc. Polyethylene air bubble film shall conform to IS 12787/AA51420 Expanded polystyrene (Thermocole) shall conform to AA51416.
- d) The cartons shall be manufactured from corrugated Fibre Board, meeting requirements of AA51414.

4.6 Special Packing

Components requiring special packing (as per customer/contractual/ engineering requirements) not included in this specification shall be covered by product standards.

5 PREPARATION OF PACKING CASE:

- 1) Export items are to be packed in sea-worthy wooden/Ply board cases.
- 2) The base of the case shall be made of wooden battens for planks giving necessary reinforcement, such that the bottom of the equipment is at a height of 100 to 200mm from the ground level depending upon size & weight of equipment. However for packing cases of smaller size equipment can be at a height of 40mm from the ground level.
- 3) The four sides & top cover shall be lined, from inside with multi-layered cross-laminated polyethylene sheet of 90GSM as per AA51420 and tacked at suitable places.

Whenever specified the top cover will have a layer of multi-layered cross laminated polyethylene sheet of 90 GSM over the cover. This should project about 100 - 250mm on all sides.

It is preferable to have a single piece of the above Multi-layered cross laminated polyethylene sheet fixed on the four sides. In case jointing is unavoidable, it should be done by overlapping of approximately 100mm.

- 4) Put the job on the base and wherever necessary may be screwed / fastened.
- 5) In case of delicate component Packing Viz. Electrical & Electronic components for instruments/ assemblies, a rubber sheet, Self-expanded polyethene foam sheet as per AA51423, preferably 10mm thick, shall be fixed on to the base to act as cushioning to the equipment.
- 6) Place the Components/cartons with corrosion inhibitors duly applied wherever necessary for place suitably, thin muslin cloths bags containing 100grams (approx.) of activated Blue Silica Gel to AA55619, wherever necessary. Alternatively VCI Powder or Tablet may be used.
- 7) In case, depression is formed, at the top, after the equipment is lowered, provide ply board/wooden batons.
- 8) Whole Equipment shall be covered and sealed with Multi-layered cross-laminated Polyethylene sheet to AA51420.
- 9) For indoor panels/equipment, provide suitable packing batons with covering of Thermocole/ expanded soft polyethylene foam/polyethylene air bubble film wrapped with suitable cords, to avoid cutting of the polyethylene sheet so that finished surface is not damaged.
- 10) Empty space in the box shall be filled with adequate cushioning material e.g. Thermocole Chips, Wood Wool etc. to avoid movement for shocks. Alternatively put wooden blocks/batons wherever necessary.
- 11) The inner side of the top cover shall be lined with M.L.C. laminated polyethylene sheet of at least 90GSM, which shall project approximately 25 to 150mm depending upon the size of the case on all sides of the top cover shall be provided below the top cover. This projection, after nailing the top cover, shall be folded over, on the sides of the crates & tacked, to, prevent ingress of water from the top.
- 12) For specific applications requiring additional protection the packing cases are covered with GI sheet on outside for sides and top; inside for bottom as per specification AA10166, thickness of G.I. sheet shall be 0.25mm.
- 13) For specific applications requiring inspection, additional inspection window has to be provided for custom clearance for export jobs.

6 SEALED PACKING:

Components sub-assemblies and assemblies sensitive to climatic conditions shall be packed seal tight. All the openings of the sensitive components, sub-assemblies and assemblies shall be blanketed to prevent the ingress of dust and moisture.

The components sub-assemblies and assemblies are completely covered with 2 layers of M.L.C. laminated poly film. All sharp corners and edges are to be protected by rubber mats to prevent the polyethylene sheet from damage. Top surface of the case shall be free from dents to prevent rain water pockets.

Certain special precautions are required for seal tight packing of specific item have to be covered by product standard.

7 OTHER PACKING MATERIAL

7.1 Volatile Corrosion Inhibitor (VCI) Paper as per AA51406:

- a) Un-protected surfaces of steel and cast iron components, tools bearing, shaft seals etc. are covered with VCI paper. VCI paper has been impregnated with corrosion inhibitors which by evaporation and chemical conversion protect metals in an enclosed area against corrosion.
- b) 7m³ VCI paper is necessary for 1 m³ of packed item approximately as per AA51406.

Application Limitation:

VCI paper shall not be used for components made of aluminium, aluminium alloys as well as Zinc, copper, brass, cadmium and silver. VCI powder is sprinkled inside the piping components ends shall be protected with end cover as specified in plant standards, drawings.

7.2 Moisture Absorber:

Silica gel is used for this purpose to protect the contents over sufficiently long time from corrosion. At the time of use, silica gel should be so dried that its colour becomes dark blue. These shall be filled in small cotton bags. Before sealing the equipment, the silica gel bags should be kept inside the polyethylene film cover at different locations. The quantity of silica gel depends on the dimension of the polyethylene sheet as well as transit and storage time.

7.3 Sling Plate:

Sling plate shall be provided to prevent damage to the packing box during lifting. Size of the sling plate shall be selected depending upon the net weight of the consignment.

7.4 Packing Slip Holders:

Two nos. of packing list with suitable protecting cover shall be fixed one inside and the other outside of the packing box as per specification AA7240901.

7.5 Nails

The length and diameter of the nails depends upon the size of planks

7.6 Strapping Strips:

These are used for strapping the boxes. Suitable size of box strapping strip can be used as per size and weight of consignment. The material shall be free from rust.

7.7 Brackets:

These brackets are used for nailing to the corners of cubicle boxes. The brackets shall be of "L" shape, suitable holes shall be provided towards the end of each side for screwing /nailing.

7.8 Fasteners:

Bolts, double nuts, spring washers of suitable size will have to be used for packing of some special items like transformers, reactors, breakers, etc., to hold the job to the bottom plank of the box.

7.9 Polyethylene Sheet:

The polyethylene sheets are used to make covers to the jobs individually. multi-layered cross laminated polyethylene sheet as per AA 51420 can be used for packing of jobs.

7.10 Expanded Poly Foam Sheet and Air Bubble Film:

This item is used for covering the delicate items, Expanded Polyethylene Foam Sheet as per specification AA51423 and air bubble film as per specification AA51426

7.11 Thermocol (Expanded Polystyrene) Sheets:

This is used for covering delicate items. This material shall be as per spec. no AA51416

7.12 Cotton Bags:

These are used for holding silica gel.

7.13 Marking Ink:

The ink used normally is black in color. In some special cases other color also will have to be used. The ink shall be non-fading/indelible and non-washable by water

7.14 Polyethylene Bags:

These are to be used for keeping the, Packing slips. The bag shall be of size 70 mm X 100 mm (minimum).

7.15 Mechanical Latching Clamps:

For specific items self locking clamps can also be used on need basis in conjunction with or apart from regular bolt and nut fixing arrangement, if needed.

8 DESIGN OF PACKING BOXES

Design/drawing of packing boxes shall be prepared based on actual weight and size of the equipment and shall be covered by concern product standards.

9 GENERAL PRECAUTIONS:

- 1) While fixing nails during packing, necessary care shall be taken to ensure that materials used for protection inside the case e.g. paper, polyethylene sheet, coir etc. do not get damaged.
- 2) Sling protection brackets to be provided on cases wherever required.
- 3) It shall be ensured that all stencil marks external, front & rear sides of the casing shall be of water proof Material to prevent obliteration in transit.
- 4) For packing of small/delicate items - Item may be wrapped properly with M.L.C. laminated polyethylene and wrapped item may be further wrapped with air bubble film as per spec. AA51426, these curtains will be subsequently packed in wooden/ply boxes as at clause 7.
- 5) The various caution signs shall be marked with stencil on both sides of the packing box.
- 6) Instructions on handling, storage, preservation, re-preservation and transport of export order components at works and site shall be covered by product standards.

10 MARKING

The following details are to be marked on the packing cases.

- a) Address of consignee.
- b) Purchase Order No.
- c) Description of item or title of packing list.
- d) Case identification Number.
- e) Net Weight.
- f) Gross Weight.
- g) Dimensions of box
- h) Marking showing upright position.
- i) Marking showing sling position.
- j) Marking showing umbrella (i.e. for machines/components to be stored under covered storage).

MARKINGS ON PACKING CASES

1. THIS PLANT STANDARD PRESCRIBES THE VARIOUS CAUTION SIGNS AND OTHER MARKINGS ON PACKING CASES.
2. DIMENSIONS IN THE TABLE 1 SHALL BE USED FOR MAKING STENCILS ONLY.

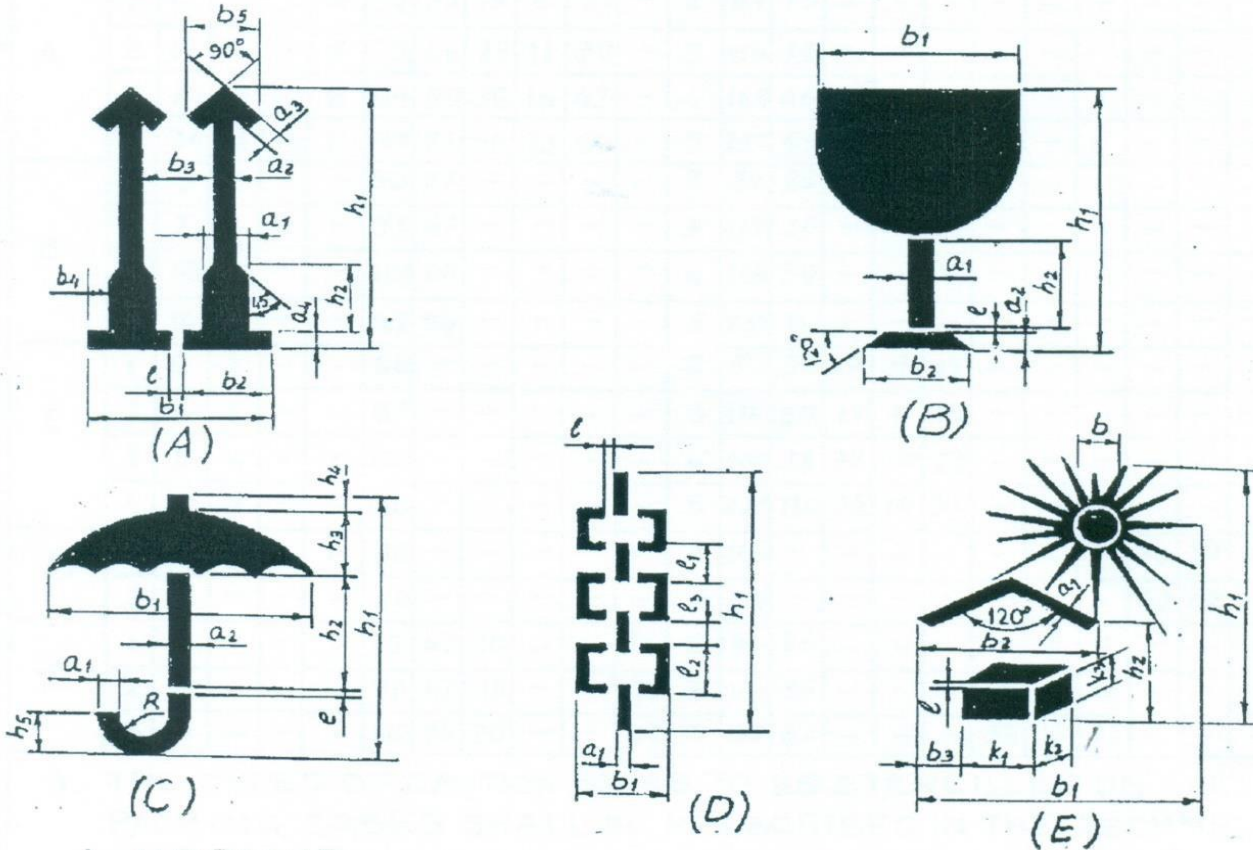

- A. UPRIGHT
- B. FRAGILE
- C. PROTECTION FROM FALLING OR CONDENSING MOISTURE.
- D. SLINGING POSITION
- E. PROTECTION FROM DIRECT RADIATIONS.

CENTER OF GRAVITY



Figure 1 - Markings

DESIGN- ATION	DIMENSIONS IN mm.																								
	α_1	α_2	α_3	α_4	b_1	b_2	b_3	b_4	b_5	b	l	h_1	h_2	h_3	h_4	h_5	K_1	K_2	K_3	l_1	l_2	l_3	R		
A	1	12	5	5	4	52	25	19	8	21	-	2	84	23	-	-	-	-	-	-	-	-	-	-	
	2	17	7	7	6	75	36	29	11	30	-	3	119	33	-	-	-	-	-	-	-	-	-	-	
	3	24	10	10	8	104	50	38	16	42	-	4	168	46	-	-	-	-	-	-	-	-	-	-	
	4	34	14	14	11	147	71	59	23	60	-	5	239	65	-	-	-	-	-	-	-	-	-	-	
B	1	5	5	-	-	50	33	-	-	-	-	2	84	25	-	-	-	-	-	-	-	-	-	-	
	2	7	7	-	-	71	47	-	-	-	-	3	119	36	-	-	-	-	-	-	-	-	-	-	
	3	10	10	-	-	100	66	-	-	-	-	4	168	50	-	-	-	-	-	-	-	-	-	-	
	4	14	14	-	-	142	94	-	-	-	-	5	239	71	-	-	-	-	-	-	-	-	-	-	
C	1	4	3	-	-	66	-	-	-	-	-	2	80	39	19	5	11	-	-	-	-	-	-	6	
	2	6	4	-	-	85	-	-	-	-	-	3	114	55	27	7	16	-	-	-	-	-	-	9	
	3	8	6	-	-	120	-	-	-	-	-	4	160	78	38	10	22	-	-	-	-	-	-	12	
	4	11	9	-	-	170	-	-	-	-	-	5	227	110	54	14	31	-	-	-	-	-	-	17	
D	1	6	-	-	-	30	-	-	-	-	-	4	148	-	-	-	-	-	-	-	-	30	30	10	-
	2	9	-	-	-	42	-	-	-	-	-	5	209	-	-	-	-	-	-	-	-	42	42	14	-
E	1	3	-	-	-	69	47	10	-	-	16	2	91	26	-	-	-	17	8	11	-	-	-	-	
	2	4	-	-	-	98	67	15	-	-	23	3	128	33	-	-	-	24	11	16	-	-	-	-	
	3	6	-	-	-	138	94	20	-	-	32	4	182	62	-	-	-	34	16	22	-	-	-	-	

Black and Red Marking Ink to IS:1234 "Ink, Stencil, Oil Base, For Marking Porous Surfaces" or duplicating ink stencilling, oil base for marking porous surfaces.

All cases containing fragile items are to be stencilled with red marking and stencilling paint/ink

"HANDLE WITH CARE", "FRAGILE DO NOT TURN OVER".

Besides the caution signs the product information's shall be stencilled of letters with 13mm to 50mm height.

Incase of consignment consists of more than one package; each package shall carry its package no as given in shipping list. All caution signs shall be stencilled in higher quality full glossy out door finishing paint red in colour (AA56126). All other markings shall be carried out in black enamel (AA56126).

Caution signs & other markings shall be stencilled on both the end shooks & the side shooks. Caution sign (for slinging) shall be stencilled only on side shooks at the appropriate place.

Note: Incase the size of package is small for using the stencils, and then hand written letters/figures shall be allowed.

11 PROCEDURE FOR HANDLING OF COMPONENTS

The purpose of this procedure is to protect the quality of the components/equipment while handling in various stages of manufacturing packing & despatching.

- 1) Adequate care shall be taken in handling the material, and components to avoid damage during receipts, storage issue manufacture & despatch operations.
- 2) Appropriate material handling equipment like fork lifters, cranes etc. Shall be used where needed.
- 3) Lifting by crane and transportation by trolley of critical items and large components like rotors castings etc. Shall be done carefully.

- 4) For critical items, where specified, special handling fixtures shall be used for lifting.
- 5) Slings and shackles used for lifting the components/equipment shall be checked for fitness and suitability before use.
- 6) Slings used on machined surfaces shall be suitably padded. No slings shall be used on journal surfaces.
- 7) Precision machined components like blades, catches, rollers etc. Shall be lifted using suitable wooden pallets.

8) HANDLING OF COMPONENTS ON RECEIPT/DESPATCH:

Before loading/unloading a packing case from the carrier look for the following shipping instructions painted on the packing case.

- The markings showing the upright position.
 - The markings showing the sling position
 - Markings showing the fragile contents.
 - Other required markings as per Cl.No:10
- a) Appropriate cranes and slings should be used for different components/ cases. Slings should normally make an angle as minimum as possible (width wise) but in no case more than 15°.
 - b) Handling and lifting should be done without jerks or impacts.
 - c) Immediately after receipt of the goods, the packing should be examined all-round for any sign of damage. If necessary, lift the cover or a number of boards of the case so as to make the contents visible. In the event of sealed packing being used the plastic sheeting should not be damaged. It is imperative that the packing material is restored in original condition after the inspection.
 - d) On receipt of the equipment it should be checked with the shipping list and missing or damage if any should be reported immediately. It is important to arrange for immediate examination to determine the extent of the damage, the cause of the damage and where applicable the person or persons responsible for the damage. According to general practice when transporting by railway or by road vehicle the carrier concerned should be immediately called upon (within specified periods) for jointly establishing a statement of the damage. This is essential as a basis for a subsequent claim and possible damage report to the insurance company.
 - e) Protective coating applied on machined surfaces should not be disturbed. The plastic covering should be put back carefully so that it prevents ingress of dust and moisture. Some packing may have vapour phase inhibitor (VPI) paper enclosed inside the packing cases. This should be restored to its original place as far as possible.
 - f) Silica gel and such other chemicals kept in the box as desiccants and indicators should also be left in the box itself.

12 Treatment of Wood & Application and use of the mark

For seaworthy export packing, treatment of wood has to be carried out as below subject to BHEL Engg & QC approval.

As per customer requirement for export packing, wood to be treated as applicable should be done as per International Standards for Phytosanitary Measures ISPM: 15 to control the growth stages viz. egg to adult of structural insects (beetles, borers, bugs, fleas, flies, lice, moths, roaches, termites) and other pests (mice, rats, spiders) etc. in stored products.

The specified marks applied to wood packaging material treated in accordance with ISPM 15 must conform to the requirements described in Annex 2 of ISPM 15.

12.1 Heat treatment using a conventional steam or dry kiln heat chamber (treatment code for the mark: HT)

When using conventional heat chamber technology, the fundamental requirement is to achieve a minimum temperature of 56 °C for a minimum duration of 30 continuous minutes throughout the entire profile of the wood (including its core).

This temperature can be measured by inserting temperature sensors in the core of the wood. Alternatively, when using kiln-drying heat chambers or other heat treatment chambers, treatment schedules may be developed based on a series of test treatments during which the core temperature of the wood at various locations inside the heat chamber has been measured and correlated with chamber air temperature, taking into account the moisture content of the wood and other substantial parameters (such as species and thickness of the wood, air flow rate and humidity). The test series must demonstrate that a minimum temperature of 56 °C is maintained for a minimum duration of 30 continuous minutes throughout the entire profile of the wood.

Treatment schedules should be specified or approved by the National Plant Protection Organisation (NPPO). Treatment providers should be approved by the NPPO.

12.2 Heat treatment using dielectric heating (treatment code for the mark: DH)

Where dielectric heating is used (e.g. microwave), wood packaging material composed of wood not exceeding 20 cm when measured across the smallest dimension of the piece or the stack must be heated to achieve a minimum temperature of 60 °C for 1 continuous minute throughout the entire profile of the wood (including its surface). The prescribed temperature must be reached within 30 minutes from the start of the treatment.

Treatment schedules should be specified or approved by the NPPO.

12.3 Methyl bromide treatment (treatment code for the mark: MB)

Wood packaging material containing a piece of wood exceeding 20 cm in cross-section at its smallest dimension must not be treated with methyl bromide.

The fumigation of wood packaging material with methyl bromide must be in accordance with a schedule specified or approved by the NPPO (National Plant Protection Organisation) that achieves the minimum concentration-time product (CT) over 24 hours at the temperature and final residual concentration specified in Table 1. This CT must be achieved throughout the profile of the wood, including its core, although the concentrations would be measured in the ambient atmosphere. The minimum temperature of the wood and its surrounding atmosphere must not be less than 10 °C and the minimum exposure time must not be less than 24 hours. Monitoring of gas concentrations must be carried out at a minimum at 2, 4 and 24 hours from the beginning of the treatment. In the case of longer exposure times and weaker concentrations, additional measurement of the gas concentrations should be recorded at the end of fumigation.

If the CT is not achieved over 24 hours, corrective action needs to be taken to ensure the CT is reached; for example, the treatment is restarted or the treatment time extended for a maximum of 2 hours without adding more methyl bromide to achieve the required CT (see the footnote to Table 2).

Table 1 – Minimum CT over 24 hours for wood packaging material fumigated with methyl bromide

Temperature (°C)	CT (g·h/m ³) over 24 h	Minimum final concentration (g/m ³) after 24 h [#]
21.0 or above	650	24
16.0 – 20.9	800	28
10.0 – 15.9	900	32

[#] In circumstances when the minimum final concentration is not achieved after 24 hours, a deviation in the concentration of ~5% is permitted provided additional treatment time is added to the end of the treatment to achieve the prescribed CT.

One example of a schedule that may be used for achieving the specified requirements is shown in Table 3.

Table 2 – Example of a treatment schedule that achieves the minimum required CT for wood packaging material treated with methyl bromide (initial doses may need to be higher in conditions of high sorption or leakage)

Temperature (°C)	Dosage (g/m ³)	Minimum concentration (g/m ³) at:		
		2 h	4 h	24 h
21.0 or above	48	36	31	24
16.0 – 20.9	56	42	36	28
10.0 – 15.9	64	48	42	32

Treatment providers should be approved by the NPPO.

12.4 Marking

The specified marks applied to wood packaging material treated in accordance with ISPM 15 must conform to the requirements described in ISPM 15.

13 PROVISION FOR INSPECTION:

This clause is applicable only where contractual requirement of customer is there. For other packings this is not applicable.

Each transportable packing's shall have provision for inspection by customer authority etc. during transport from origin of dispatched until destination. This inspection may require opening of the package and subsequently closing it again. For this purpose, suitable designed opening with bolted cover shall be provided. Such an opening shall be clearly marked as "OPENING" with clear instruction for opening & closing written on this cover. For large consignment, the size of the opening shall be suitable to facilitate entry of personnel.

14 REFERRED STANDARDS (Latest publications including amendments):

- | | | | |
|------------|------------|------------|------------|
| 1) AA51401 | 2) IS:303 | 3)IS:710 | 4)AA10166 |
| 5)ISPM:15 | 6)AA51420 | 7)AA51423 | 8)55619 |
| 9)AA51406 | 10)AA51416 | 11)AA51426 | 12)AA56126 |

VOLUME IIB

**TECHNICAL SPECIFICATION
FOR
SEAWORTHY PACKING FOR EXPORT JOBS**

SPECIFICATION NO. PE-TS-888-100-A001



**BHARAT HEAVY ELECTRICALS LIMITED
POWER SECTOR
PROJECT ENGINEERING MANAGEMENT
NEW DELHI, INDIA**

	TITLE	SPECIFICATION NO. PE-TS-888-100-A001	
	TECHNICAL SPECIFICATION FOR SEAWORTHY PACKING FOR EXPORT JOBS	VOLUME II B	
		SECTION D	
		REV. NO. 0	DATE 10/08/2010
		SHEET 1 OF 52	

1.0 Purpose

The purpose of this specification is to describe minimum packing requirements for the different items/equipment for all export Project and also to define marking and shipping requirements during transportation by ship, road and air for all export jobs.

2.0 SCOPE

For export jobs, sea worthy packing capable of performing all necessary functions like prevention of damage to the contents, sufficient to support frequent handling and lengthy period of outdoor storage in adverse weather conditions are required. Workmanship and materials used shall be of high standard meeting the technical requirements and in accordance with best commercial export packing practices. Vendor shall be responsible for sea worthy export packing, however it shall meet the minimum requirements specified herein. Equivalent or better packing methods may be deployed subject to approval of the BHEL/Purchaser. Vendor shall submit the packing procedure for its equivalent for purchaser's approval during detailed engineering.

The scope this specification is to define VENDOR's responsibilities in terms of:

- Preservation of the GOODS/items/equipments before packing.
- Packing of the GOODS for road, rail, sea and/or air transportation to desired destination i.e. project site
- Making cases/crates
- Chemical Treatment/Fumigation before packing to prevent fungus, damage due to termite, borer, rats, etc.
- Marking of cases/crates.
- Other Services required.

3.0 Application

This specification is applicable to all the goods to be transported to project site and requires to be in transit for longer duration. *However, for "Misc cable erection items", "Fire sealing system" & "Exothermic welding material", the packing requirements shall be as per the procurement specification.*

4.0 Definitions

- "BHEL" : Main EPC vendor
- "OWNER" : Customer for a particular export project.
- "VENDOR" : Company(ies)/VENDOR(s) to whom the BHEL has placed Purchase Order for GOODS/ items/system/package.
- "GOODS": means all or part of the articles, material, equipment supplies including technical documentation, as described in the Purchase Order, to be supplied by VENDOR.
- "PACKER": Packaging Company to whom VENDOR intends to sub-contract the packing in case they do not have own packing capability/facilities .
- "FREIGHT FORWARDER" : Means the Company responsible for performing freight forwarding activities.

5. General Information

	TITLE	SPECIFICATION NO. PE-TS-888-100-A001	
	TECHNICAL SPECIFICATION FOR SEAWORTHY PACKING FOR EXPORT JOBS	VOLUME II B	
		SECTION D	
		REV. NO. 0	DATE 10/08/2010
		SHEET 2	OF 52

The following requirements are intended as minimum requirements, and compliance to these requirements in no way absolves or relieves VENDOR of any responsibility or obligation outlined in the Purchase Order. In all circumstances, the packing will be designed and constructed in order to support GOODS during transportation as well as to prevent the Goods from damage due to impact, extreme climatic conditions, sun and rain. It must be ensured that the delivery of the GOODS to the jobsite by sea, road or air, in good condition.

GOODS shall be export packed in compliance with the best-established practices for international projects, in accordance with the following instructions. In the event of any conflict between these specified requirement and the established practices, specification requirement shall govern.

Due to climatic conditions and the complex transport operation(s), it is essential that protection and packing is of the highest standard. Packing means to efficiently protect the GOODS during the total transport operation; from the moment they leave the factory until they are delivered to the jobsite, including handling operations (loading/unloading) and storage.

When VENDOR do not have packing capabilities/facilities of their own and therefore intends to sub-contract, VENDOR have to inform BHEL/Purchaser of the name and address of proposed PACKER(s) for approval.

6.0 Criteria for Selection of Packaging

Packages are to be made according to categories, described in articles 8.1 to 8.5, depending on the type of materials, their fragility and size.

These categories have been established for the protection of equipment and material during multi-mode transports, i.e.: combination of overland and sea transport; containerization, air transportation.

In a general manner, the GOODS have to be packed in such a way that crates, bundles, pallets can be stored into General Purpose containers, wherever possible.

If VENDOR has any doubt about the correct method of protection or packing, he should contact BHEL/Purchaser in order to mutually agree on the adequate type of packing to be used.

Materials can be classified in following categories

- Hazardous Material
- Non-Hazardous Material
-

Further to above categorisation, non-hazardous materials can be sub- categorised for selection of packing.

6.1 Hazardous Materials

Though handling of hazardous material may is not applicable in the scope of this specification. All hazardous material must be packed in adherence to the detailed requirement relating to packing, marking and labelling set out in the most recent report of the Board's Standard Advisory Committee on the Carriage of Dangerous Goods in Ships for sea freight, and the Restricted Articles Regulations, laid down by the International Air Transport Association for airfreight.

6.2 Non-Hazardous GOODS

The scope of this specification is to provide necessary guidelines for packing for power plant equipment, components, Pipings & Valves, Fittings, other structural items, electrical items, spare parts and erection materials. The procedure is defined in subsequent paragraphs in details in clause no. 8.0.

	TITLE	SPECIFICATION NO. PE-TS-888-100-A001	
	TECHNICAL SPECIFICATION FOR SEAWORTHY PACKING FOR EXPORT JOBS	VOLUME II B	
		SECTION D	
		REV. NO. 0	DATE 10/08/2010
		SHEET 3	OF 52

7.0 Marking Instructions & Despatch details, Storage Code

7.1 Marking Instructions & despatch details

Packages and crates will be marked with indelible black paint, resistant to seawater. Marking must be perfectly legible.

The shipping marks, which will be as per fig-13, shall be stencilled on two sides and one end in clear characters at least 5 centimetres high (where crate size permits, otherwise use optimum size for each package dimension).

When the GOODS are to be shipped in containers then marking may be stencilled on one end only. However, packages must be stowed in a manner that shows these marks.

Crates containing fragile articles must be packed with special precaution against risk of breakage and must be stencilled on all sides "FRAGILE - HANDLE WITH CARE". Where crates are not to be overturned, VENDOR must show on the crates, clear and readily visible identification as per fig-12, to ensure they are kept in the correct position.

Packages/equipment of 2,000 kg or more must be marked with slinging points on all sides, in addition to the centre of gravity marks.

Number packages consecutively i.e. 1 of 10, 2 of 10, etc. Do not duplicate package numbers. VENDOR is responsible for any loss or damage caused by incorrect marking.

All cases/crates shall also be marked with the appropriate international standard graphic symbols for handling as shown in Fig 12.

As a minimum, all cases/crates are to be marked clearly on all four sides with:

- "HANDLE WITH CARE"
- "RIGHT SIDE UP"
- "KEEP DRY"

In the case of packages with a single gross weight totalling 2,000 kg and/or a height of more than 1m, the centre of gravity shall be clearly marked with the symbol on two adjoining sides. For all items of equipment with an eccentric centre of gravity this symbol shall be marked at the bottom, side and top of the package.

The slinging and lashing points shall be marked with a chain symbol.

When packing in cases/crates, these packages shall also have metal corners at the slinging points. (Fig-11)

External front and rear sides of the boxes to be planed for writing instructions.

Dispatch details such as consigner/consignee address, contract and case details, country of origin, port of delivery, stacking instructions shall be written on one side of the boxes. An anodized aluminum plate as per details and specifications given in fig-13 shall be provided on one side of the boxes.

One copy of packing slip wrapped in polyethylene bag covered with aluminum packing slip holder to be nailed on the external surface of the box. One more copy of the packing slip wrapped in polyethylene bag is to be kept inside the box at the pertinent place.

	TITLE	SPECIFICATION NO. PE-TS-888-100-A001	
	TECHNICAL SPECIFICATION FOR SEAWORTHY PACKING FOR EXPORT JOBS	VOLUME II B	
		SECTION D	
		REV. NO. 0	DATE 10/08/2010
		SHEET 4	OF 52

7.2 Storage Code

The type of storage required is required to be specified, it will be shown on each packaging in **RED colour**.

- X Crates or packages to be stored outdoor without covers
- XX Crates or packages to be stored under tarpaulin
- XXX Crates or packages to be stored in covered or enclosed premises
- XXXX Crates or packages which must be stored in air-conditioned premises

8.0 GUIDELINES FOR PACKING GOODS

8.1 In the subsequent paragraphs details of different types of packings for different types of GOODS are defined. Vendor shall make packing details/procedure based on the guidelines and submit for approval.

8.1.1 Packing for Pipe, Fittings, Flanges and Valves, Structural Steel

Particular attention should be brought to pipe, fittings, flanges, valves and structural steel. Packing categories for piping and fittings will differ according to the diameter and wall thickness of these products. VENDOR shall comply with the following established practice.

IMPORTANT NOTE:

Depending on the project schedule and availability of ocean vessels, the piping and structural steel may be shipped in containers. In this event, VENDOR has to arrange the packages in such a way it allows the stuffing into Open Top in gauge containers.

8.1.2 Pipe

Where practicable, pipe lengths shall be limited to 11.8 meters.

All pipes 2" included and below shall be packed in crates. All pipes to be capped and ends sealed with waterproof tape.

Pipes over 2" up to 6", shall be bundled and banded in bundles of uniform length. Bundling is carried out with U-IRON or traversal planks, joined with threaded connecting rods with locknuts. Quantities and strapping positions depend on the lengths, with a 120 cm spacing to prevent distortion. Bundle weight shall not exceed 2,000 kg. All pipes are to be capped and ends sealed with waterproof tape (tape is not necessary if end caps are of the pre-shrunk or self-sealing type).

Pipes larger than 6" shall be shipped as single lengths with the ends capped. End caps are to be of the recessed type to enable the use of soft faced hooks, but still completely sealing the end and also protecting the weld.

All stainless steel piping must be packed separately in wooden crates. Any banding of bundles is to be with the same material.

8.1.3 Pipe Fittings, Flanges and Valves

All pipe fittings, flanges and valves up to 6", are to be packed in cases/crates. For items over 6", these may be fixed securely to a pallet base and enclosed in a crate, for protection. Where valves have actuators attached, rigidity must be ensured for the valve and actuator. The vulnerable parts of the actuator are to be completely protected within a wooden crate.

All stainless steel fittings, flanges and valves of all sizes, must be packed separately in wooden crates. Any strapping is to be with the same material.

8.1.4 Structural Steel

	TITLE	SPECIFICATION NO. PE-TS-888-100-A001	
	TECHNICAL SPECIFICATION FOR SEAWORTHY PACKING FOR EXPORT JOBS	VOLUME II B	
		SECTION D	
		REV. NO. 0	DATE 10/08/2010
		SHEET 5 OF 52	

Structural Steel, reinforcing rods, bars, etc., should be packed in bundles of uniform length. Refer to articles 8.1.2, for strapping requirements. Bundle weight not normally to exceed 2,000 kg. Fabricated structures and structural steelwork, etc, should be bundled and packed using wooden beams and long bolting to secure the load.

8.2 Bundling – Packing Category I

8.2.1 Type of Equipment

Equipment which is not subject to damage by corrosion or mechanical effect, i.e. pipes, piping, structural steel.

Packing category I

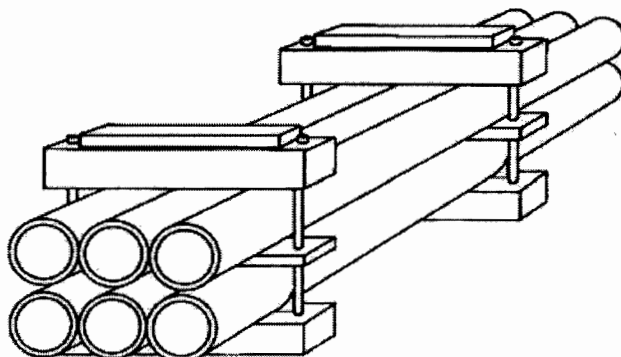

Bundling by U-shaped iron – packing category I A

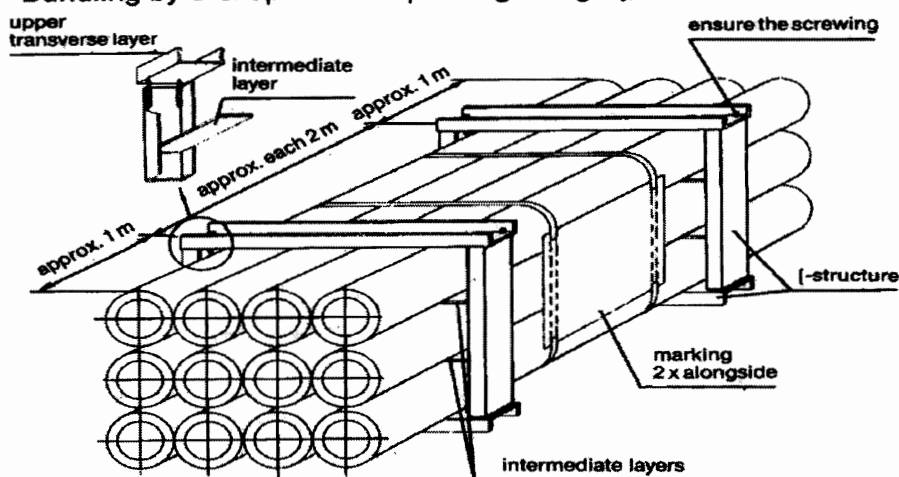

8.2.2 Type of Construction

	TITLE	SPECIFICATION NO. PE-TS-888-100-A001	
	TECHNICAL SPECIFICATION FOR SEAWORTHY PACKING FOR EXPORT JOBS	VOLUME II B	
		SECTION D	
		REV. NO. 0	DATE 10/08/2010
		SHEET 6	OF 52

- Bundling has to be effected
- By squared timber and threaded rods.
- With an intermediate layer (threaded on tightening bolts) according to the weight of the package.
- Wedge-shaped timbers must be added at the outer points of lower layer.
- Between the bolts a spacer must be nailed.
- The bolts must be secured (e.g. by locking nut).
- If single parts could protrude, an appropriate protection must be installed (flat iron or plates).
- Bundling with steel straps or PVC straps is not accepted.

8.3 Skids, Square Timber Constructions, Casings – Packing (Category II)

8.3.1 Type of Equipment

Voluminous apparatus, tanks and/or heavy pieces those are not vulnerable to mechanical or corrosive effects.

8.3.2 Type of Construction

- The construction skid can be made of wood or of metal.
- The fastening of the packages on the skid will be made by steel straps (flat iron) which have to be elastically lined, non-slip and securely bolted onto the skids.
- Flange openings have to be closed with gaskets and blind flanges or, if necessary, provided with cover.
- Skid constructions may not be less than the dimensions of the package in length or in width.
- Tanks and apparatus with their own support cradles must be supplied with an anti-slip lining.

PACKING CATEGORY-II

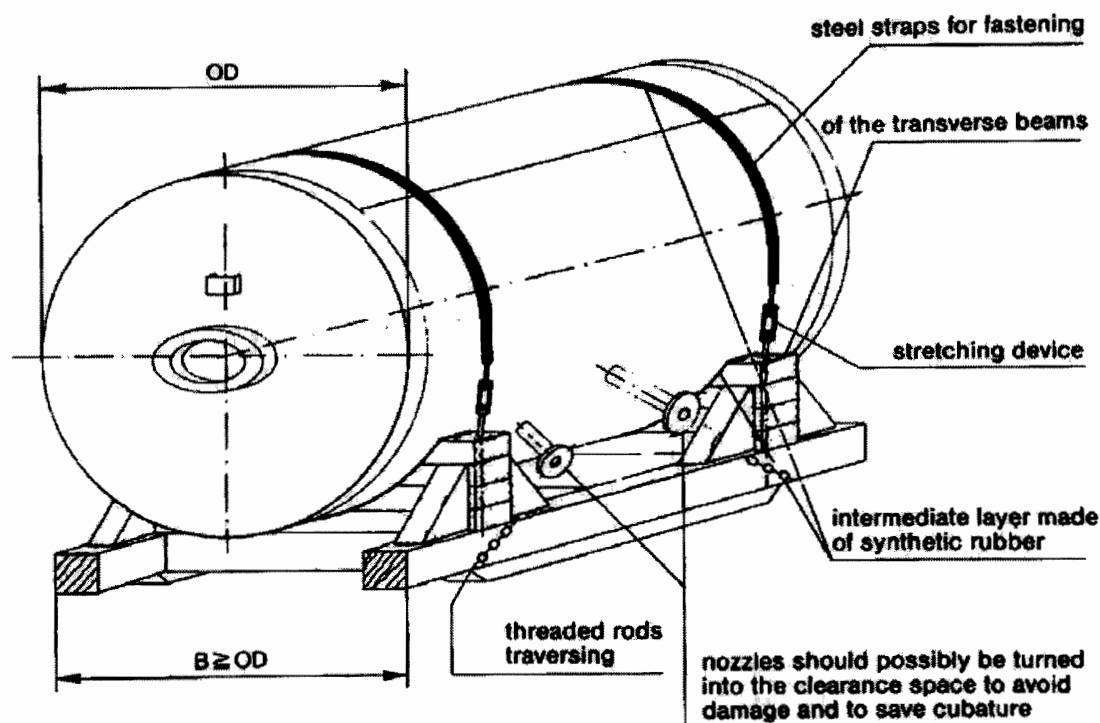

	TITLE	SPECIFICATION NO. PE-TS-888-100-A001	
	TECHNICAL SPECIFICATION FOR SEAWORTHY PACKING FOR EXPORT JOBS	VOLUME II B	
		SECTION D	
		REV. NO. 0	DATE 10/08/2010
		SHEET 7 OF 52	

8.4 Packing of GOODS in Wooden Crates/Cases/Boxes

The construction of wooden crate/cases/boxes shall be as per the details indicated in clause 9.0 & Fig 1 to 11. Details indicated in the sketches for different categories Packing crates/boxes are only for a typical equipment considered for illustration.

8.4.1 Packing Category III

8.4.1.1 Type of Equipment

Fabricated equipment, which cannot be transported on cradles; frame-works, prefabricated piping and fittings, mechanical and electrical assemblies. *This type of packing is recommended where many parts of the equipment/component/assembly are not protruding out.*

8.4.1.2 Type of Construction

The equipment must be safely fastened to the bottom with bolts, possibly by the runners or to be spread in such a manner that no protruding parts are possible. For parts, sensitive to rainwater and/or debris, a protection has to be made by a foil cap.

If it is possible that single part could protrude through the front/back side wall, they shall be closed completely. The marking of the package shall be done on plywood plates at the prescribed sides.

Packing Category III

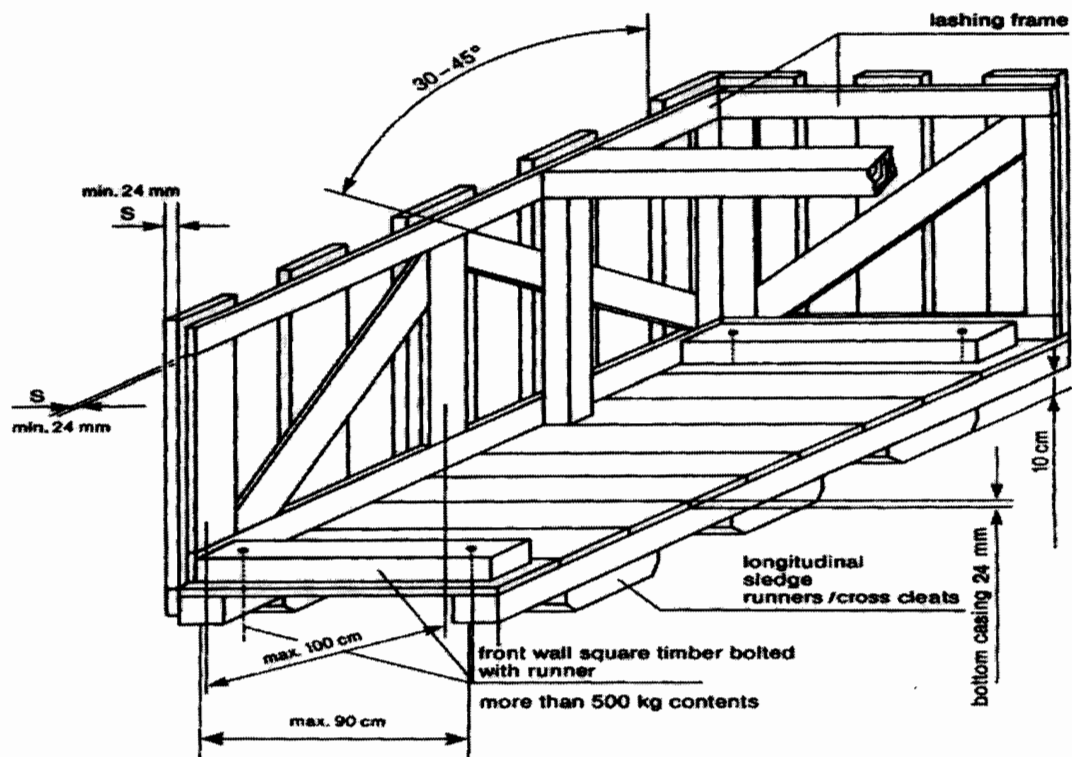

	TITLE	SPECIFICATION NO. PE-TS-888-100-A001
	TECHNICAL SPECIFICATION FOR SEAWORTHY PACKING FOR EXPORT JOBS	VOLUME II B
		SECTION D
		REV. NO. 0 DATE 10/08/2010
		SHEET 8 OF 52

8.4.2 Cases with Lining – Packing Category IV

8.4.2.1 Type of Equipment

Recommended for equipment and mechanical parts Equipment sensitive to mechanical damage or parts and components that are particularly at risk of theft or loss; pumps, elbows, flanges, fittings, tools, erection materials, etc.

8.4.2.2 Type of Construction

The same type of construction as article 8.4.1.2, but with all sides completely boarded without space between the boards. Sides to be provided with waterproof lining; fabric-reinforced waterproof tar paper or polyethylene-foils resistant to ultraviolet rays can be used. Polyethylene-foil shall be fixed under the lid cover to avoid penetration of water. At weights of more than 500 kg the longitudinal runner must be bolted to the front all square timber. For ventilation inside the case, an opening in the waterproof lining must be placed between the diagonal battens and diagonal joists.

Packing Category IV

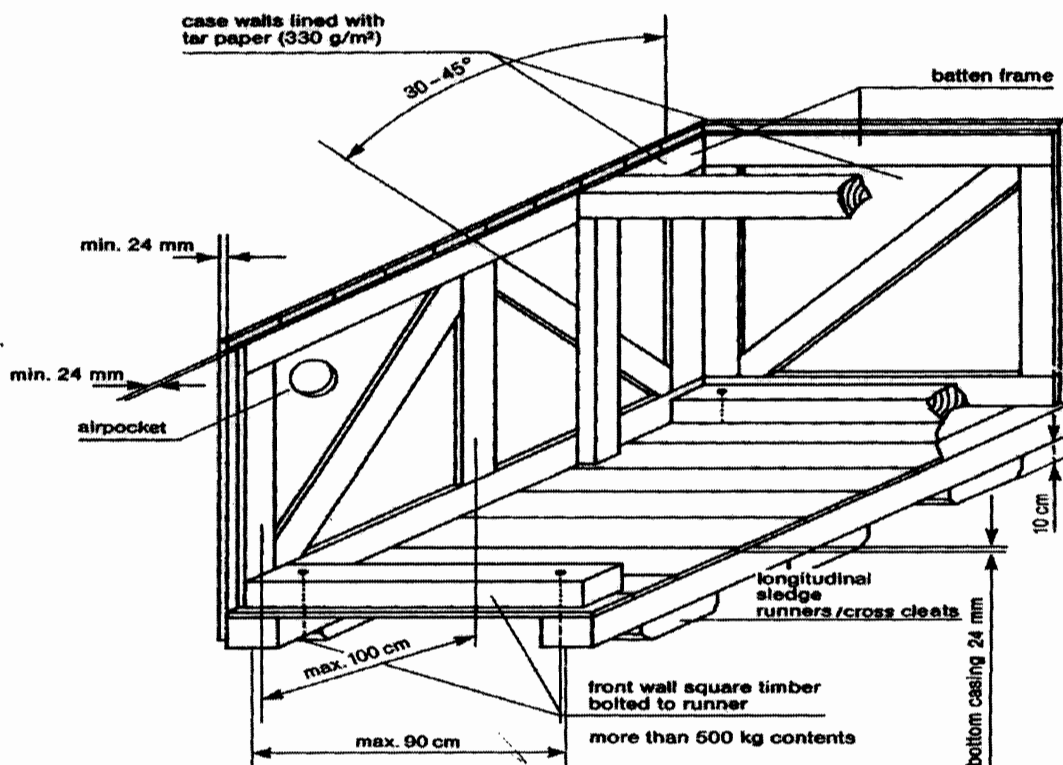

8.4.3 Cases with Alternative Surface Materials

8.4.3.1 Plywood Box – Packing Category IV A

	TITLE	SPECIFICATION NO. PE-TS-888-100-A001
	TECHNICAL SPECIFICATION FOR SEAWORTHY PACKING FOR EXPORT JOBS	VOLUME II B
		SECTION D
		REV. NO. 0 DATE 10/08/2010
		SHEET 9 OF 52

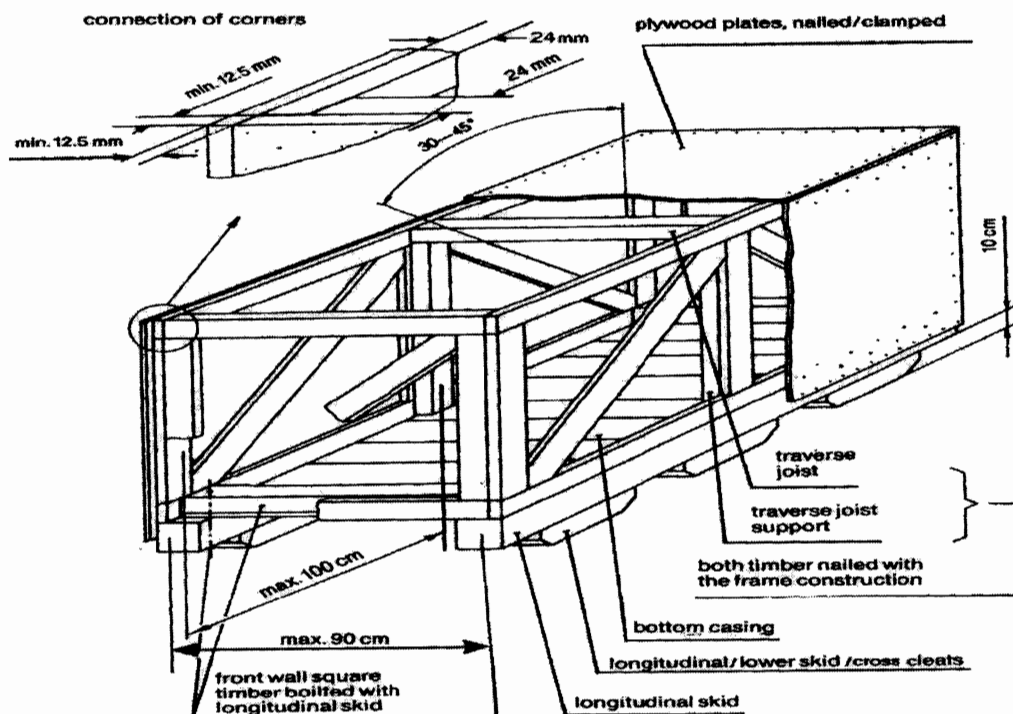

Case constructed of 5 layers of watertight, glued plywood with a total thickness of 12.5 mm. The frame must be constructed from minimum 24 mm timber or as per guide lines given above against clause 8.0, Fig 1 to 11 and must be suitable for the weight and nature of the parts to be packed. Planed square timber must be bolted with longitudinal skid and covered with diagonal joists. If applicable, construction of the cover and sides is to include diagonal bracing. Covers consisting of several layers of plywood are to be sealed with durable elastic putty or additional water-resistant sheets to be fixed.

8.4.4 Case with Barrier Material – Polyethylene Foil – Packing Category V

8.4.4.1 Type of Equipment

Sensitive equipment, simple electrical equipment, insulation materials, fire-resistant materials, with non-corrosion- guarantee for a period up to twelve (12) months.

8.4.4.2 Type of Construction

Preservation by welding in polyethylene-foil with addition of desiccants and if necessary, application of non-corrosive contact agents, otherwise, type of construction as indicated in article 8.4.2.2.

Additional marking:

- Case with desiccants.

8.4.5 Case with Barrier Material – Aluminium Compound Foil – Packing Category VI

8.4.5.1 Type of Equipment

	TITLE	SPECIFICATION NO. PE-TS-888-100-A001	
	TECHNICAL SPECIFICATION FOR SEAWORTHY PACKING FOR EXPORT JOBS	VOLUME II B	
		SECTION D	
		REV. NO. 0	DATE 10/08/2010
		SHEET 10	OF 52

Electrical equipment such as, switchboards, electric motors, sensitive equipment, with non-corrosion guarantee, for a period up to twelve (12) months.

8.4.5.2 Type of Construction

Type of construction as indicated in article 8.4.2.2. Preservation by sealing an aluminium compound foil, with the addition of desiccants. Humidity indicators, if required and installed in the barrier wrapping, shall allow easy control from the outside.

Additional marking:

- Case with desiccants.

Packing Category V/VI

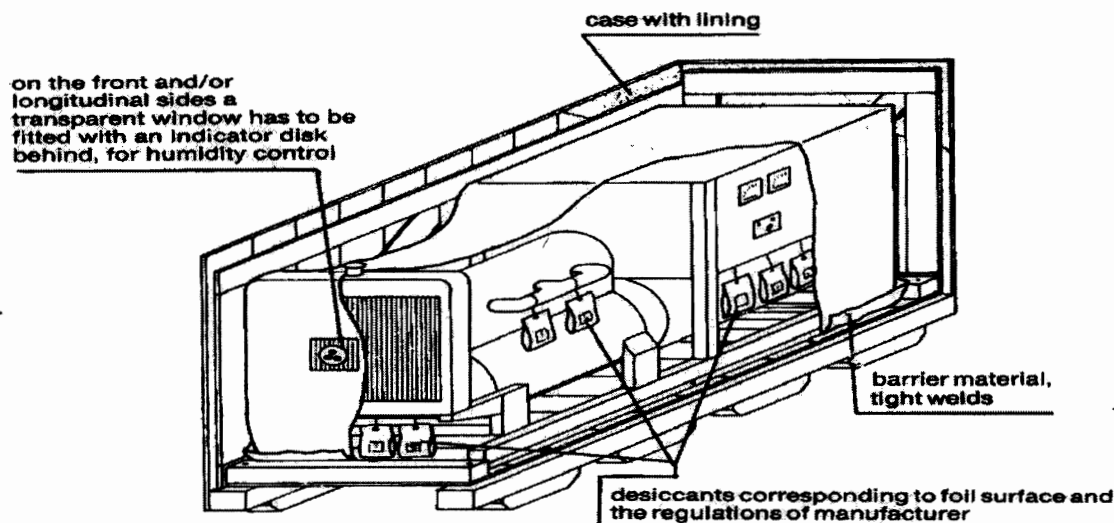

8.4.6 Double Case – Packing Category VII

8.4.6.1 Type of Equipment

GOODS which are of high sensitivity to shock, impact and vibration, for instance, special electrical equipment like computers, switchboards, laboratory instruments

8.4.6.2 Type of Construction

Case construction as indicated in article 8.4.2.2, with additional floating inner packing (case-in-case principle), padding corresponding to weight and sensitiveness. Preservation by sealing in aluminium compound foil with the addition of desiccants. The inner case has to be made of plywood or equivalent material with a thickness of 8-12 mm, depending on the weight of the GOODS to be packed. The inner buckles and/or frame borders have to be dimensioned so that the full stability of the inside case will be reached and no twisting is possible. The inner sides of the inside case will be lined with bituminous kraft paper on all sides (except bottom).

	TITLE	SPECIFICATION NO. PE-TS-888-100-A001	
	TECHNICAL SPECIFICATION FOR SEAWORTHY PACKING FOR EXPORT JOBS	VOLUME II B	
		SECTION D	
		REV. NO. 0	DATE 10/08/2010
		SHEET 11	OF 52

8.4.7 Cable Drum – Packing Category VIII

8.4.7.1 Type of Equipment

All type of cables, wires, ropes, hoses.

8.4.7.2 Type of Construction

For all type of cables refer clause no. 11.1. For other items (wires, ropes, hoses) new or practically new drums are to be used. Planking of the e drums by use of boards, thickness minimum 20 mm, with additional double steel strapping, nailed, and carefully preserved/ protected cable ends prior to packing.

8.4.8 Hazardous Materials – Packing Category IX

8.4.8.1 Type of Equipment

Hazardous materials according to the law are explosives, compressed gases, liquefied gases dissolved under pressure or deeply refrigerated, flammable liquids, flammable solids: substances liable to spontaneous combustion; substances which, on contact with water, emit flammable gases, oxidizing substances, organic peroxides, poisonous (toxic) and infectious substances; radioactive materials, corrosives, miscellaneous dangerous goods.

8.4.8.2 Type of Construction

Hazardous materials shall always be packed and documented separately from any other material. Selection of packaging materials, execution of packing and marking as well as documentation shall always be in compliance with the applicable laws and regulations. Any certificates required for transportation or for authorities to be supplied before shipment of the GOODS.

8.4.9 Wooden Floor as a Transport Support – Packing Category X

8.4.9.1 Type of Equipment

Any materials to be stuffed in containers or on flat racks and that are not stowed on standard pallets or otherwise suitably packed

8.4.9.2 Type of Construction

- Longitudinal internal square timbers bolted to the front wall runners, longitudinal skid.
- Maximum distance between longitudinal runners 90 cm (middle to middle of the runner).
- Full boarding of the floor.
- Attaching of lifting lugs and/or iron ropes for lifting/pulling the units off the transport equipment.
- If applicable, preservation of the equipment by sealing in polyethylene-foil or aluminium compound foil and the addition of desiccants.

8.5 Air Transport Packing

8.5.1 General

Certain types of material may have to be shipped by air from their country of origin. This means of transport will be exceptional, and will be used only:

- For GOODS, which are highly sensitive to shock or vibrations, such as computers, electronic instruments, or those of small dimensions and weight.
- For GOODS urgently required at the module yard(s) and/or jobsite.

	TITLE	SPECIFICATION NO. PE-TS-888-100-A001	
	TECHNICAL SPECIFICATION FOR SEAWORTHY PACKING FOR EXPORT JOBS	VOLUME II B	
		SECTION D	
		REV. NO. 0	DATE 10/08/2010
		SHEET 12	OF 52

8.5.2 Type of Packing

Depending on the goods to be packed, VENDOR may use one of the following types:

- A triple-corrugated cardboard container made with waterproofed glue and a barrier layer of polyethylene on the outsides to keep out humidity.
- Wooden/cardboard packing cases: the wood being used for the framework and base of the cases, waterproofed triple-corrugated cardboard being used for the sides and top. These cases are of the "Bell" type, and used for material of small or medium dimensions.
- For larger dimensions, plywood cases are acceptable. The timber characteristics, cross-sections and thickness will be systematically determined by the nature of the loads to be packed.

8.5.3 Dimensions

In order to optimize the existing transport facilities (passenger or cargo aircraft), the dimensions of:

- Triple-corrugated containers.
 - Wooden/cardboard packing cases.
 - Plywood cases.
- Are to be adapted to pallets used for air transportation.

9.0 Detailed specification for Wooden Crates/Boxes/Cases and other packing materials

9.1 Technical specification for wood

The wood shall be Fir, Chir, Silver Oak (Gravillea Robusta), chemically treated mango and Pinewood with moisture content not exceeding 50%. The wood shall have flexural and compressive strength, stiffness, shock absorption and nail retention properties. The wood shall be free from common defects such as warp, bone, twist, knot, cracks, splits, end splits, bend, visible sign of infection and any kind of decay caused by insects or fungus, etc. Surface cracks with maximum depth of 3mm are permissible. A continuous crack of any depth all along the length is not allowed.

9.2 Chemical Treatment of Wood:

The wood shall be chemically treated to provide protection against deterioration due to fungi and attack by termites, borers, marine organism and any other kind of infection. It shall be treated only after final processing like cutting, planning, joint grooving, etc.

9.3 TYPE, DESIGN & DIMENSION OF WOODEN PACKING CASES:

9.3.1 PACKING OF EQUIPMENTS

Various mechanical, electrical and C&I equipment e.g. Pumps, motors, equipment skids, heat exchangers, control panels, switch gears, transformers, etc. shall be wrapped in weather proof packing and then secured in wooden packing cases. The construction of wooden packing cases/crates shall be as per details given below and also given in figure 1 to 11.

9.3.1.1 Bottom Frame

	TITLE	SPECIFICATION NO. PE-TS-888-100-A001	
	TECHNICAL SPECIFICATION FOR SEAWORTHY PACKING FOR EXPORT JOBS	VOLUME II B	
		SECTION D	
		REV. NO. 0	DATE 10/08/2010
		SHEET 13	OF 52

The construction of bottom frame shall be as per Fig-2. The No. of slides/runners for bottom frames shall be selected depending upon the weight and overall dimensions of the load to be carried. The equipment shall be secured by fixing their base frame/plate with the help of bolt and nuts etc. to bottom frame of the wooden packing cases/crates. The equipment not provided with base frame/plate like cylindrical vessels, etc to be secured to the bottom frame of the wooden cases with "C" clamps fabricated from steel channels/ angle iron.

9.3.1.2 TOP FRAME

The construction of top frame shall be as per fig-3.

9.3.1.3 END PANELS

The dimension of the end and lateral panels shall be calculated according to overall dimensions of the items to be packed. Diagonal braces shall be used for packing cases having height exceeding 500mm. Details of bracings shall be as per fig 5 to 9.

9.3.1.4 Sling Plate

To facilitate lifting of cases, longitudinal under slide boards shall be fixed. To avoid damage to the box while lifting sling plates shall be provided. Refer fig-11.

9.3.1.5 Angle Iron Cleats

Angle iron cleats shall be used for strengthening the joints as indicated in fig-10

9.3.1.6 Other Requirements

- The thickness of planks for top, bottom, side and end panels shall be at least 25mm. Planks used for this purpose shall be joined with each other by tongue and groove joint. The groove dimension shall be such that tongue fits tightly into groove to make the joint.
- Runners/slides, traverse bars, etc shall be of single length i.e. without any joint. Planks for sheathing, diagonal bracing etc shall also be of single length up to 2400mm, proper jointing is permitted for planks for sheathing and diagonal bracings.
- Each equipment to be individually covered with double polyethylene petticoat. Sheet thickness of polythene sheet shall not be less than 0.175 mm (175 microns). The sealing shall be such so as not to allow moisture inside.
- The inner surface of 4 sides of shooks shall be nailed with bituminized water proof craft paper. Wherever 2 pieces of kraft paper are used, joint shall have an overlap of minimum 20 mm.
- All the inner sides of the box shall be nailed with bitumen coated HESSIAN POLYTHYLENE KRAFT PAPER. For top frame it shall project on all sides by 100mm and shall be nailed on sides. Wherever 2 pieces of kraft paper are used, joint shall have an overlap of minimum 20 mm.
- For delicate equipment like control panels and switchgears, lighting panels and lighting transformers, suitable cushioning material like rubberised coir (min. 50 mm thick and 100 mm wide) shall be provided on their bottom support and the gap between the panel and casing

	TITLE	SPECIFICATION NO. PE-TS-888-100-A001	
	TECHNICAL SPECIFICATION FOR SEAWORTHY PACKING FOR EXPORT JOBS	VOLUME II B	
		SECTION D	
		REV. NO. 0	DATE 10/08/2010
		SHEET 14	OF 52

shall be filled with rubberized coir with distance between consecutive supports less than 500 mm (ref fig15). For other equipment suitable support from sides of the casing shall be provided.

- Switchgear cubicles, control panels and control desks shall be packed and shipped in separate convenient sections. The components e.g. circuit breakers relays and instruments etc. which are removed from panels for shipping purpose and shall be separately packed and shipped as per packing instructions in clause 10.4.
- Packing case for control panels and switchgear panels shall be finally covered with GI sheet of minimum thickness of 0.4mm.
- Packing cases shall be bound at edges by nailing MS clamps/brackets at sufficient intervals. Further heavier boxes shall be strapped with C clamps (ref fig-4) fabricated from steel channels/angles and lighter boxes shall be strapped with hoop iron strips.
- Silica gel is used for this purpose to protect contents over sufficiently long time from corrosion. Silica gel shall be indicating type confirming to IS-304 (1979) packed in cotton bags placed at different positions inside the packing for absorbing moisture and shall not come into directly contact with equipment/material inside the package. The quantity of silica gel shall be adequate for storage period of one year, however it shall not be less than 4 gm. per ltr. Volume of case subject to minimum 400 gm. Per case.

	TITLE	SPECIFICATION NO. PE-TS-888-100-A001	
	TECHNICAL SPECIFICATION FOR SEAWORTHY PACKING FOR EXPORT JOBS	VOLUME II B	
		SECTION D	
		REV. NO. 0	DATE 10/08/2010
		SHEET 15	OF 52

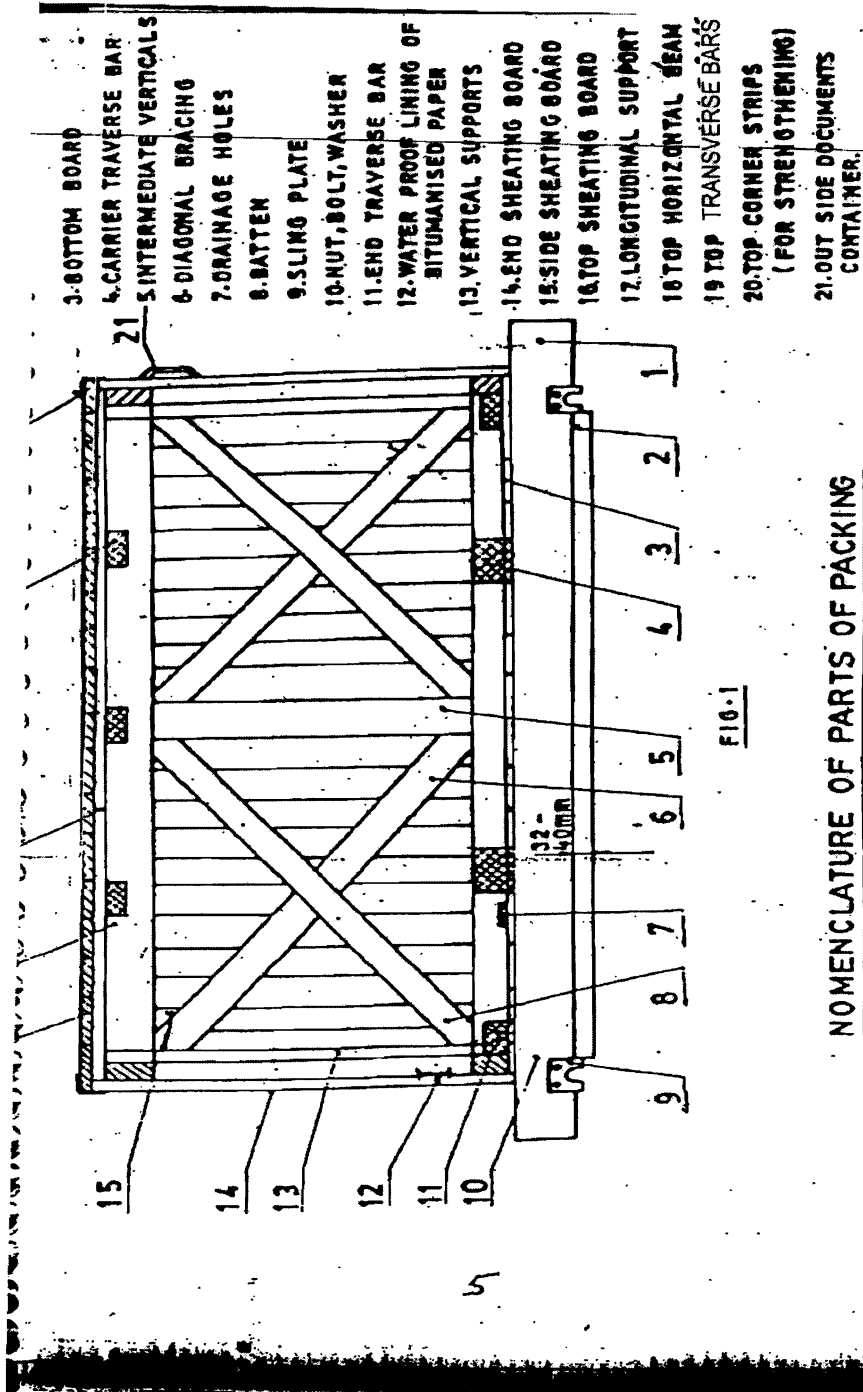

EC-009

028

	TITLE	SPECIFICATION NO. PE-TS-888-100-A001	
	TECHNICAL SPECIFICATION FOR SEAWORTHY PACKING FOR EXPORT JOBS	VOLUME II B	
		SECTION D	
		REV. NO. 0	DATE 10/08/2010
		SHEET 16	OF 52

BOTTOM FRAME ARRANGEMENTS

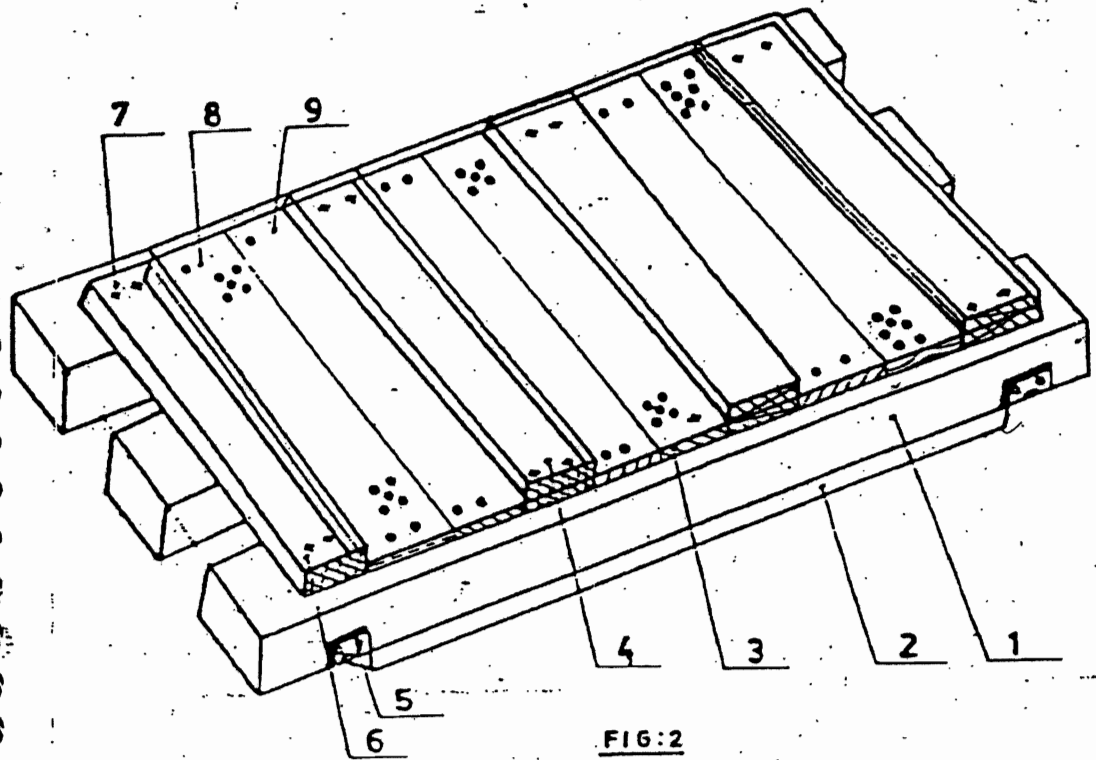

FIG:2

*Nos. of slides: Minimum 2 Nos.
For length more than 1800 mm or
load more than 1000kg, nos. of
slides shall be minimum 3 Nos.
For dimensions of slides, refer Table 1
Cross section of end traverse bar; 100 x 100 mm.
(minimum)*

- 1. SLIDE
- 2. UNDER SLIDE BOARD
- 3. BOTTOM BOARD
- 4. CARRIER TRAVERSE BAR
- 5. SLING PLATE
- 6. TRAVERSE BAR
- 7. BOLT, NUT & WASHER
- 8. DRAINAGE HOLES
- 9. NAILS

027

6

0007

	TITLE	SPECIFICATION NO. PE-TS-888-100-A001
	TECHNICAL SPECIFICATION FOR SEAWORTHY PACKING FOR EXPORT JOBS	VOLUME II B
		SECTION D
		REV. NO. 0 DATE 10/08/2010
	SHEET 17 OF 52	

TOP FRAME ARRANGEMENT

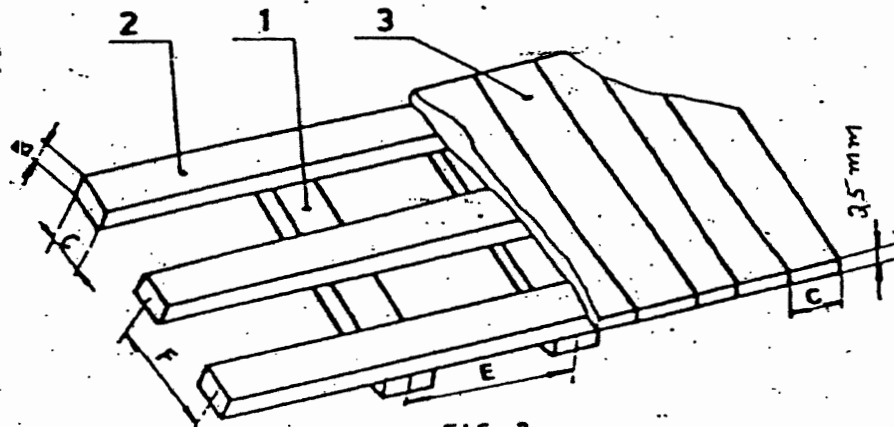
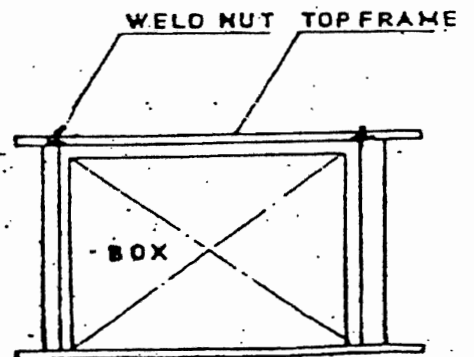
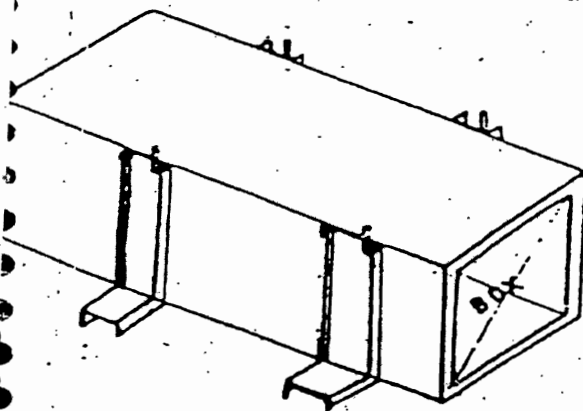

FIG-3

F : 700 to 1000 mm
 E : 500 to 900 mm
 : 30x100 mm.

- 1 - Traverse Bars
- 2 - Horizontal Soams
- 3 - Top Board

ARRANGEMENT OF C-CLAMPS AROUND CASES



028

	TITLE	SPECIFICATION NO. PE-TS-888-100-A001
	TECHNICAL SPECIFICATION FOR SEAWORTHY PACKING FOR EXPORT JOBS	VOLUME II B
		SECTION D
		REV. NO. 0 DATE 10/08/2010
		SHEET 18 OF 52

**ARRANGEMENT OF DIAGONAL BRACING AND
HORIZONTAL SUPPORT**

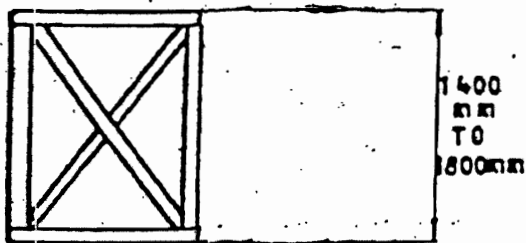

FIG: 6

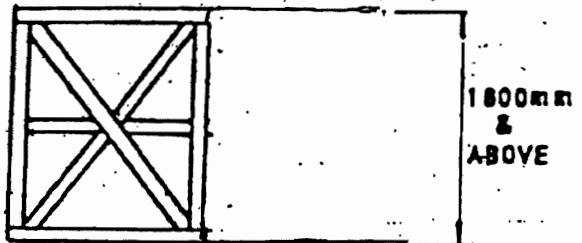

FIG: 8

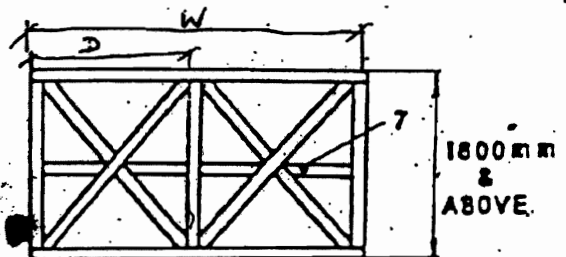

FIG: 7

7- Middle Horizontal Support

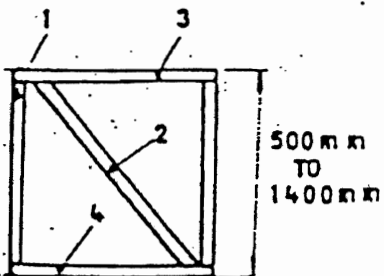

FIG: 5

1- Vertical Support

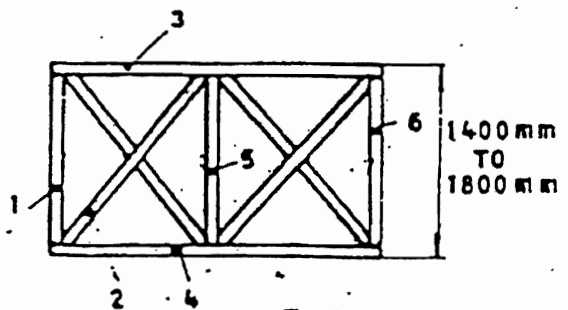



FIG: 7

1, 5, 6 - Vertical Support

029

	TITLE	SPECIFICATION NO. PE-TS-888-100-A001
	TECHNICAL SPECIFICATION FOR SEAWORTHY PACKING FOR EXPORT JOBS	VOLUME II B
		SECTION D
		REV. NO. 0 DATE 10/08/2010
		SHEET 19 OF 52

ARRANGEMENT OF PACKING CASE

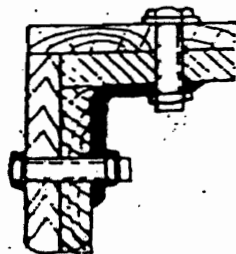
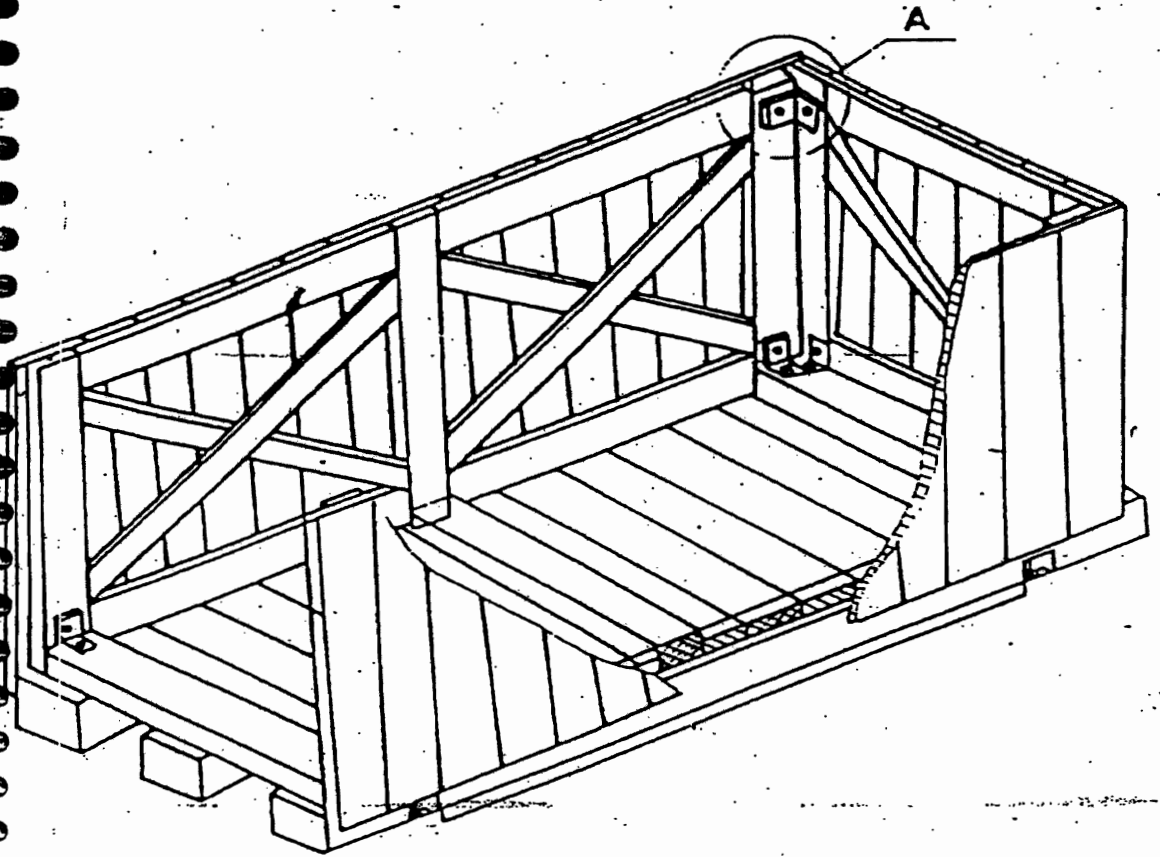

DETAIL-A

HOLE DIAMETER
MUST CONFORM
TO BOLT DIA

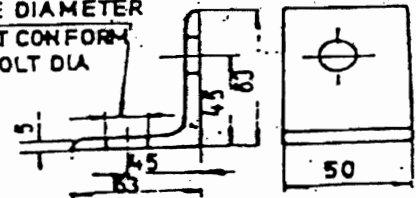



FIG:10

030

	TITLE	SPECIFICATION NO. PE-TS-888-100-A001
	TECHNICAL SPECIFICATION FOR SEAWORTHY PACKING FOR EXPORT JOBS	VOLUME II B
		SECTION D
		REV. NO. 0 DATE 10/08/2010
		SHEET 20 OF 52

ARRANGEMENT OF SLING & PLATE ON

CASES

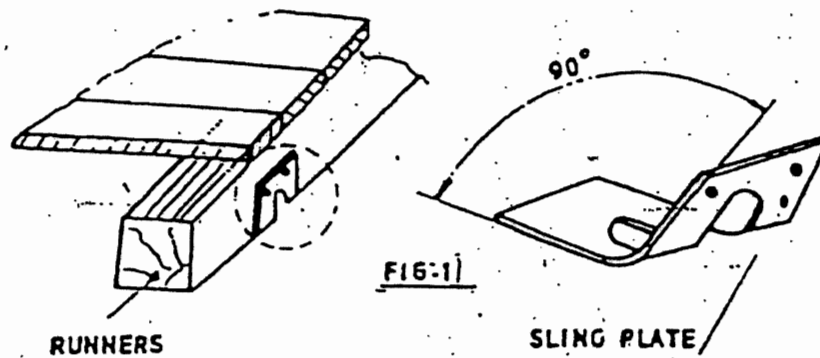

031

	TITLE	SPECIFICATION NO. PE-TS-888-100-A001	
	TECHNICAL SPECIFICATION FOR SEAWORTHY PACKING FOR EXPORT JOBS	VOLUME II B	
		SECTION D	
		REV. NO. 0	DATE 10/08/2010
		SHEET 21	OF 52

TABLE-1

LOADS	LENGTHS OF SLIDES						
	600	800	1000	1200	1300	1500	2000
	Cross section b x c						
500	50 X 100	50 X 100	50 X 100	50 X 100	75 X 100	75 X 100	100 X 100
800	50 X 100	50 X 100	75 X 100	75 X 100	75 X 100	75 X 100	100 X 100
1000	75 X 100	75 X 100	75 X 100	100 X 100	100 X 100	100 X 110	100 X 150
1500	75 X 100	75 X 100	100 X 100	100 X 100	100 X 100	100 X 150	100 X 150
2000	75 X 100	100 X 100	100 X 100	100 X 150	100 X 150	100 X 150	150 X 150
2500	75 X 100	100 X 100	100 X 150	100 X 150	100 X 150	150 X 150	150 X 150
3000	100 X 100	100 X 150	150 X 150	150 X 150	150 X 150	150 X 150	150 X 150





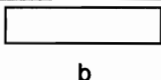



	TITLE	SPECIFICATION NO. PE-TS-888-100-A001	
	TECHNICAL SPECIFICATION FOR SEAWORTHY PACKING FOR EXPORT JOBS	VOLUME II B	
		SECTION D	
		REV. NO. 0	DATE 10/08/2010
		SHEET 22	OF 52

Table-2

End and side panels	Width of the panel "W"	Distance between longitudinal support (Dimension "D")						
		600	800	1000	1200	1400	1600	1800
		Cross section b x c				Item 1 to 7		
Fig- 5 to Fig-9	600 to 1200	30	30	30	30	30	30	30
		X	X	X	X	X	X	X
	1201 to 1600	100	100	100	130	130	130	130
		X	X	X	X	X	X	X
	1601 to 2000	30	30	30	30	30	30	30
		X	X	X	X	X	X	X
	2001 to 3000	130	130	130	130	130	130	130
		X	X	X	X	X	X	X
	3001 to 4000	30	30	30	30	30	30	40
		X	X	X	X	X	X	X
		130	130	130	130	130	130	150
		X	X	X	X	X	X	X
		40	40	40	40	40	40	40
		X	X	X	X	X	X	X
		150	150	150	150	150	150	150
		X	X	X	X	X	X	X

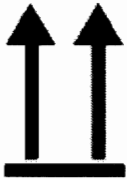
	TITLE	SPECIFICATION NO. PE-TS-888-100-A001	
	TECHNICAL SPECIFICATION FOR SEAWORTHY PACKING FOR EXPORT JOBS	VOLUME II B	
		SECTION D	
		REV. NO. 0	DATE 10/08/2010
	SHEET 23	OF 52	

INDICATION MARKS ON CASES/BOXES/CRATES

Designation	Symbol	Explanation
Fragile, Handle with care		The symbol should be applied to easily broken cargoes. Cargoes marked with this symbol should be handled carefully and should never be tipped over or slung.
Use no hooks		Any other kind of point load should also be avoided with cargoes marked with this symbol. The symbol does not automatically prohibit the use of the plate hooks used for handling bagged cargo.
Top		The package must always be transported, handled and stored in such a way that the arrows always point upwards. Rolling, swinging, severe tipping or tumbling or other such handling must be avoided.
Keep away from heat (solar radiation)		Compliance with the symbol is best achieved if the cargo is kept under the coolest possible conditions. In any event, it must be kept away from additional sources of heat. It may be appropriate to enquire whether prevailing or anticipated temperatures may be harmful.
Protect from heat and radioactive sources		Stowage as for the preceding symbol. The cargo must additionally be protected from radioactivity.
Sling here		The symbol indicates merely where the cargo should be slung, but not the method of lifting. If the symbols are applied equidistant from the middle or center of gravity, the package will hang level if the slings are of identical length. If this is not the case, the slinging equipment must be shortened on one side.
Keep dry		Cargo bearing this symbol must be protected from excessive humidity and must accordingly be stored under cover. If particularly large or bulky packages cannot be stored in warehouses or sheds, they must be carefully covered with tarpaulins.

	TITLE	SPECIFICATION NO. PE-TS-888-100-A001	
	TECHNICAL SPECIFICATION FOR SEAWORTHY PACKING FOR EXPORT JOBS	VOLUME II B	
		SECTION D	
		REV. NO. 0	DATE 10/08/2010
		SHEET 24	OF 52

Center of gravity		This symbol is intended to provide a clear indication of the position of the center of gravity. To be meaningful, this symbol should only be used where the center of gravity is not central. The meaning is unambiguous if the symbol is applied onto two upright surfaces at right angles to each other.
No hand truck here		The absence of this symbol on packages amounts to permission to use a hand truck on them.
Stacking limitation		The maximum stacking load must be stated as "... kg max.". Since such marking is sensible only on packages with little loading capacity, cargo bearing this symbol should be stowed in the uppermost layer.
Clamp here		Stating that the package may be clamped at the indicated point is logically equivalent to a prohibition of clamping anywhere else.
Temperature limitations		According to regulations, the symbol should either be provided with the suffix "...°C" for a specific temperature or, in the case of a temperature range, with an upper ("...°C max.") and lower ("...°C min.") temperature limit. The corresponding temperatures or temperature limits should also be noted on the consignment note.
Do not use forklift truck here		This symbol should only be applied to the sides where the forklift truck cannot be used. Absence of the symbol on other sides of the package amounts to permission to use forklift trucks on these sides.
Electrostatic sensitive device		Contact with packages bearing this symbol should be avoided at low levels of relative humidity, especially if insulating footwear is being worn or the ground/floor is nonconductive. Low levels of relative humidity must in particular be expected on hot, dry summer days and very cold winter days.

	TITLE TECHNICAL SPECIFICATION FOR SEAWORTHY PACKING FOR EXPORT JOBS	SPECIFICATION NO. PE-TS-888-100-A001	
		VOLUME II B	
		SECTION D	
		REV. NO. 0	DATE 10/08/2010
SHEET 25 OF 52			

Do not destroy barrier		A barrier layer which is (virtually) impermeable to water vapor and contains desiccants for corrosion protection is located beneath the outer packaging. This protection will be ineffective if the barrier layer is damaged. Since the symbol has not yet been approved by the ISO, puncturing of the outer shell must in particular be avoided for any packages bearing the words "Packed with desiccants".
Tear off here		This symbol is intended only for the receiver.

FIG-12

	TITLE	SPECIFICATION NO. PE-TS-888-100-A001	
	TECHNICAL SPECIFICATION FOR SEAWORTHY PACKING FOR EXPORT JOBS	VOLUME II B	
		SECTION D	
		REV. NO. 0	DATE 10/08/2010
SHEET 26 OF 52			



		BHEL-PEM-DELHI-INDIA			
CONSIGNEE					
MATERIAL					
CUSTOMER REF.			MO. NO.		
DESPATCH ADVICE NOTE NO.			CASE NO.		
DIMENSIONS(MM) LXBXH			NET WT -KGS		GROSS WT -KGS
SPECIAL INSTRUCTIONS	HANDLE WITH CARE -- KEEP DRY DO NOT DROP -- DO NOT TILT				

FIG-13: MARKING PLATE

535

	TITLE	SPECIFICATION NO. PE-TS-888-100-A001	
	TECHNICAL SPECIFICATION FOR SEAWORTHY PACKING FOR EXPORT JOBS	VOLUME II B	
		SECTION D	
		REV. NO. 0	DATE 10/08/2010
		SHEET 27	OF 52

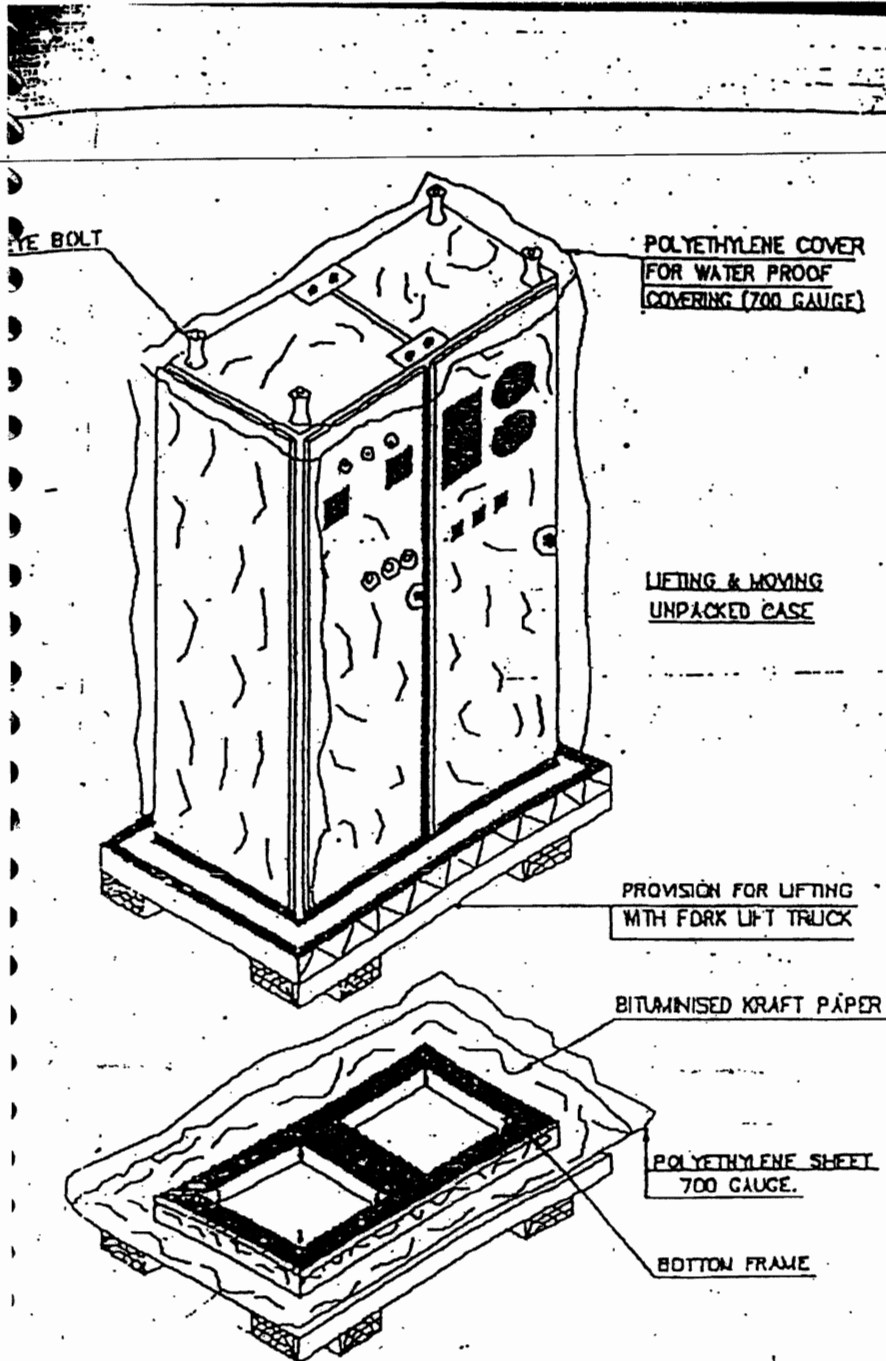



FIGURE-14

	TITLE	SPECIFICATION NO. PE-TS-888-100-A001		
	TECHNICAL SPECIFICATION FOR SEAWORTHY PACKING FOR EXPORT JOBS	VOLUME II B		
		SECTION D		
		REV. NO. 0	DATE 10/08/2010	
		SHEET 28	OF	52

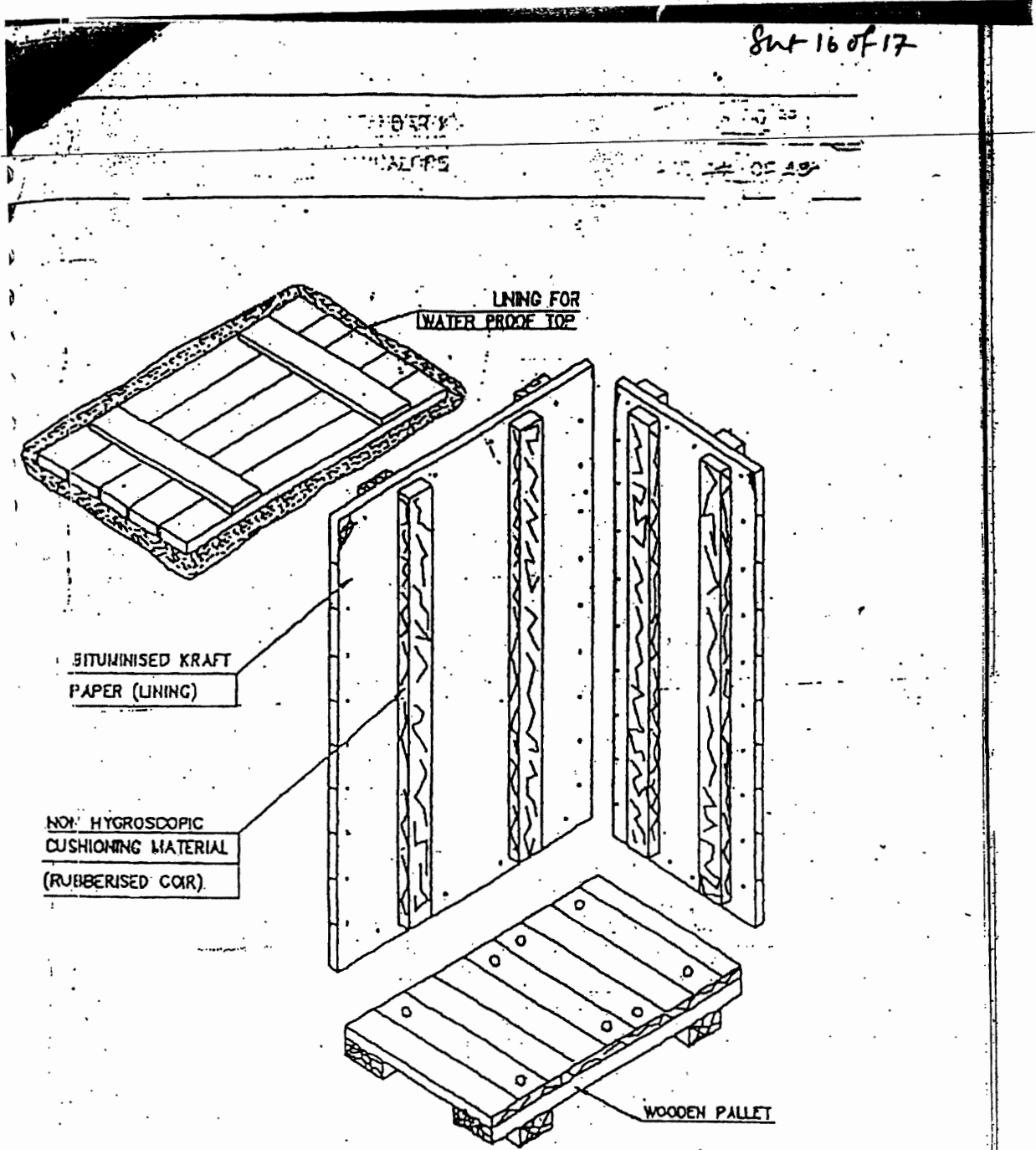

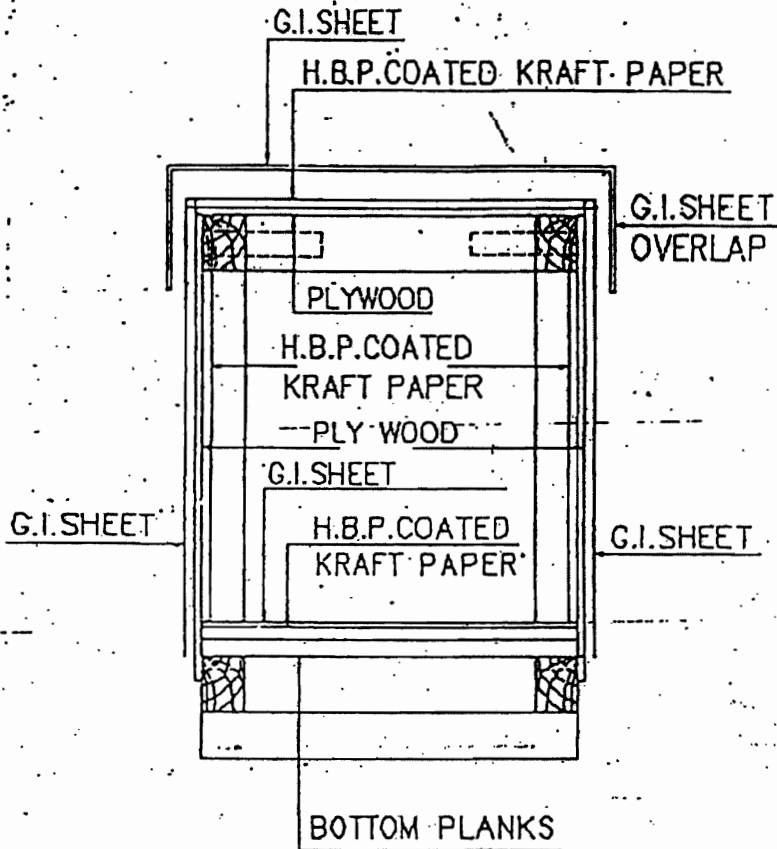



FIGURE-15

	TITLE	SPECIFICATION NO. PE-TS-888-100-A001	
	TECHNICAL SPECIFICATION FOR SEAWORTHY PACKING FOR EXPORT JOBS	VOLUME II B	
		SECTION D	
		REV. NO. 0	DATE 10/08/2010
		SHEET 29	OF 52



**FIG-16 : CLOSED PACKING CASE WITH G.I.SHEET
SHOWING LAYERS OF PACKING MATERIALS.**

	TITLE	SPECIFICATION NO. PE-TS-888-100-A001	
	TECHNICAL SPECIFICATION FOR SEAWORTHY PACKING FOR EXPORT JOBS	VOLUME II B	
		SECTION D	
		REV. NO. 0	DATE 10/08/2010
		SHEET 30	OF 52

10.0 TYPICAL PACKING DETAILS/PROCEDURE FOR MECHANICAL ITEMS

10.1 INSULATION MATERIAL (MINERAL WOOL MATTRESSES)

This specification covers the requirements of seaworthy packing and marking for bonded mineral (rock) wool mattresses having metallic hexagonal wire netting as facing on one or both sides.

10.1.1 TYPE OF CONSTRUCTION

Mattress shall be packed in Polythene (of 0.2 mm thickness) all around and sealed to prevent moisture absorption during transit and storage. Further it shall be wrapped with Bitumen coated Polythene bonded/lined Hessian and stitched and then packed in 5 ply DFC carton box.

Silica gel is used for this purpose to protect contents over sufficiently long time from corrosion. Silica gel shall be of indicating type conforming to IS:304-1979 packed in cotton bags placed at different positions inside the packing for absorbing moisture and shall not come into direct contact with the material inside the package. The quantity of silica gel shall be enough for storage period of one year. However, it shall not be less than 4 gms per litre volume of case subject to minimum of 400 gms per case.

Each mattress as well as the packages shall be serial numbered. Also, printed sheets indicating the nominal thickness, density and wire netting details (i.e. material and size) shall be placed below the wire netting.

Following details shall be legibly written on the packages. The details shall also be typed on a sheet of paper & kept in a sealed Polythene cover, inside the packages

- a) Project Name
- b) Purchase Order No.
- c) Sl. No. of package
- d) Size of mattress (Thickness x Length x Width)
- e) Density
- f) Wire netting material and size
- g) Weight of the package

10.2 INSULATION MATERIAL (ALUMINIUM COIL)

Heavy Gauge Aluminium Coil Packaging are done by Eye-to-Sky packaging or by Eye to eye packaging as per the proven practice being followed by manufacturer of Aluminium sheets.

10.2.1 Type of construction for Eye to Sky packaging

- a. Strapping of coil with polyester strap around circumference at one place.
- b. Putting paper I. D. Edge protector.
- c. Wrapping the coil with VCI stretch film after putting silica gel bags (4 nos.) Inside the coil.
- d. Wrapping the coil with HDPE film.
- e. Covering the coil including its build up & bore with masonite / particle board.
- f. Putting metallic I. D on coil.
- g. Putting O.D edge protector (paper) on coil.

	TITLE	SPECIFICATION NO. PE-TS-888-100-A001	
	TECHNICAL SPECIFICATION FOR SEAWORTHY PACKING FOR EXPORT JOBS	VOLUME II B	
		SECTION D	
		REV. NO. 0	DATE 10/08/2010
		SHEET 31	OF 52

- h. Putting circumferential polyester strap (3 nos.) & eye polyester strap (4 nos.).
- i. After placing the coil on coil tilter ply wood (10mm thick) of suitable size along with wooden pallet is to be put at the bottom side of the coil.
- j. Coil is to be tilted to eye-to-sky position.
- k. Final strapping with metallic strap to unit coil and skid at 2 places with top cover of plywood.
- l. Fixing the coil with wooden blocks at 4 corners.
- m. Labeling 2 nos.(one metallic & one adhesivetype) For specification, net wt. & gross wt.

10.2.2 Type of construction for Eye to Eye packaging

- a. Strapping of coil with polyester strap around circumference at one place.
 - b. Putting paper I. D. Edge protector.
 - c. Wrapping the coil with VCI stretch film after putting silica gel bags (4 nos.) Inside the coil.
 - d. Wrapping the coil with HDPE film.
 - e. Covering the coil including its build up & bore with masonite / particle board.
 - f. Putting metallic I. D on coil.
 - g. Putting O.D edge protector (paper) on coil.
 - h. Putting circumferential polyester strap (3 nos.) & eye polyester strap (4 nos.).
 - i. Placing of coil on wooden skid Coil is to be tilted to eye-to-sky position.
 - j. Final strapping of coil and skid at 2 places with steel strap. Fixing the coil with wooden blocks at 4 corners.
- Labeling 2 nos.(one metallic & one adhesive type) For specification net wt. & gross wt.

10.3 Packing Procedure for Online Tube Cleaning System and accessories

This procedure is applicable for the shipment of Onload Tube Cleaning System and accessories by sea.

10.3.1 Packing details:

- The Packing case shall be made of treated rubber wood. The design of the case shall be as per Annexure IIIA & IIIB.
- The Equipments shall be placed on the wooden base of the Packing case and fastened if required to arrest the movement of the same.
- Equipment shall be covered by Polythene sheet and inside wall surfaces of the wooden cases also shall be covered by polythene sheet.
- All Nozzles shall be closed with plywood dummies.
- All electrical components assembled or loose shall be covered with polythene sheets along with silica gel pack.
- Silica gel desiccants shall be kept inside each case in sufficient quantities in order to absorb the moisture.

	TITLE	SPECIFICATION NO. PE-TS-888-100-A001	
	TECHNICAL SPECIFICATION FOR SEAWORTHY PACKING FOR EXPORT JOBS	VOLUME II B	
		SECTION D	
		REV. NO. 0	DATE 10/08/2010
		SHEET 32	OF 52

- Thermocol packing shall be made for glass items like Ball vessel sight glass, Vpiece sight glass & pressure gauge.
- Silica gel desiccants shall be kept inside of each case to absorb the moisture.
- A Packing list covered in a polythene envelope shall be fixed inside and outside of each packing case.
- Shipping marks and consignee address shall be painted on the outer surface of the case.
- All handling instruction required for the case like top, sling, rain, handle with care etc, shall be marked on the case as per the symbol attached.
- Machined surface will be applied with Anti rust oil and covered by polyurethane sheet to protect from external oxidation.
- All valves will be closed with dummies to protect the internals and placed in the wooden case which will covered by polyurethane sheet.

	TITLE	SPECIFICATION NO. PE-TS-888-100-A001	
	TECHNICAL SPECIFICATION FOR SEAWORTHY PACKING FOR EXPORT JOBS	VOLUME II B	
		SECTION D	
		REV. NO. 0	DATE 10/08/2010
		SHEET 33	OF 52

MODEL: FASTNERS TYPE (BASE, SIDE & TOP ATTACHED WITH BOLT, NUT & WASHER)

This Type of case to be used for following items:

1. BALL SEPERATOR
2. BALL COLECTOR SKID

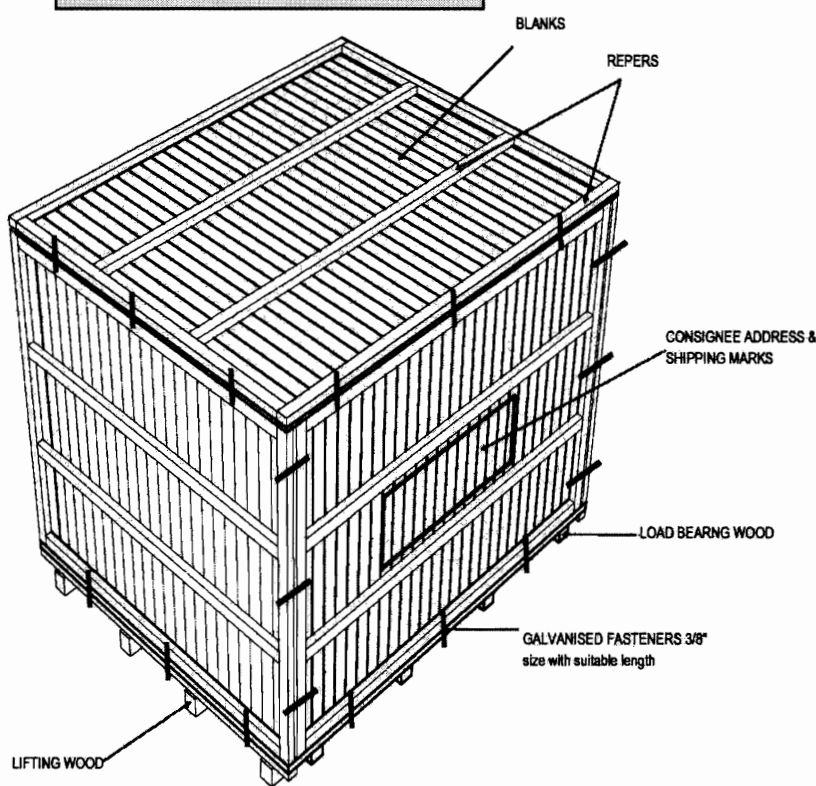

SHEET 05 of 10

	TITLE	SPECIFICATION NO. PE-TS-888-100-A001		
	TECHNICAL SPECIFICATION FOR SEAWORTHY PACKING FOR EXPORT JOBS	VOLUME II B		
		SECTION D		
		REV. NO. 0	DATE 10/08/2010	
		SHEET 34	OF	52

BASE FRAME

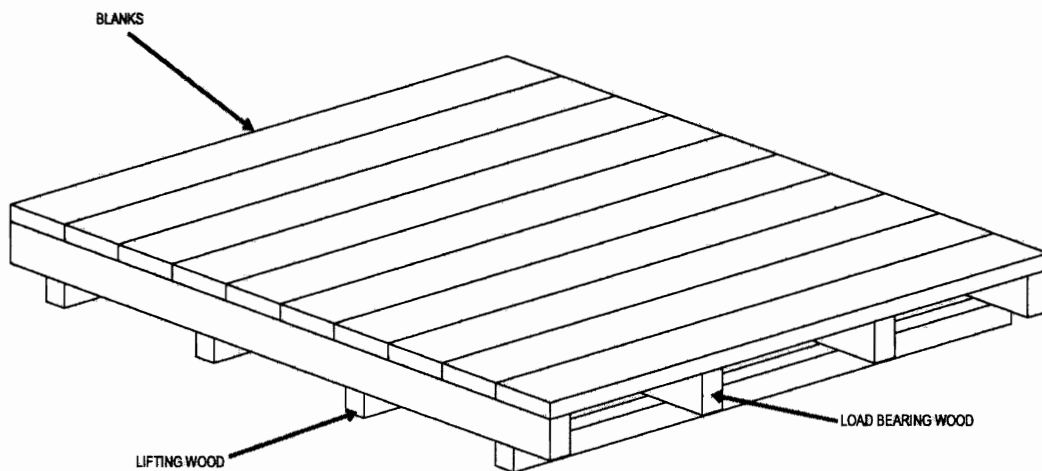

SHEET 06 of 10

	TITLE	SPECIFICATION NO. PE-TS-888-100-A001	
	TECHNICAL SPECIFICATION FOR SEAWORTHY PACKING FOR EXPORT JOBS	VOLUME II B	
		SECTION D	
		REV. NO. 0	DATE 10/08/2010
		SHEET 35	OF 52

MODEL: FASTNERS TYPE - WITHOUT TOP

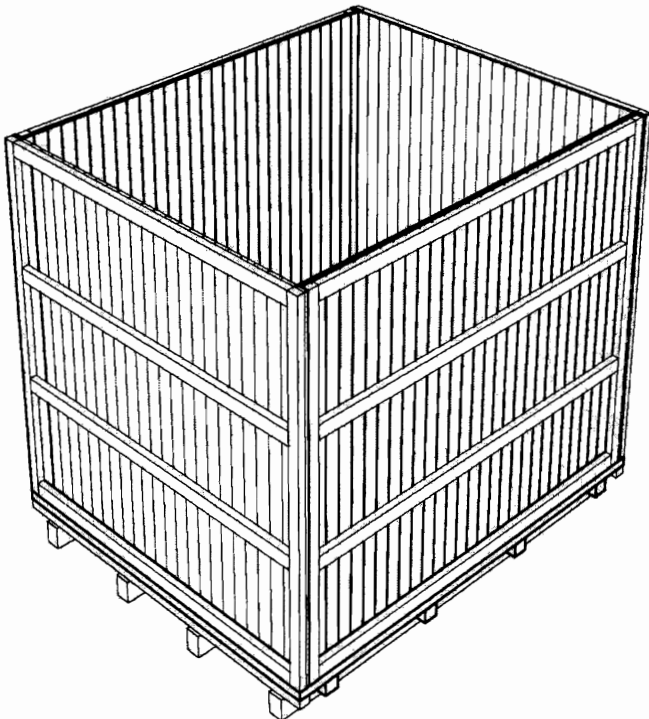

SHEET 07 of 10

	TITLE	SPECIFICATION NO. PE-TS-888-100-A001	
	TECHNICAL SPECIFICATION FOR SEAWORTHY PACKING FOR EXPORT JOBS	VOLUME II B	
		SECTION D	
		REV. NO. 0	DATE 10/08/2010
		SHEET 36	OF 52

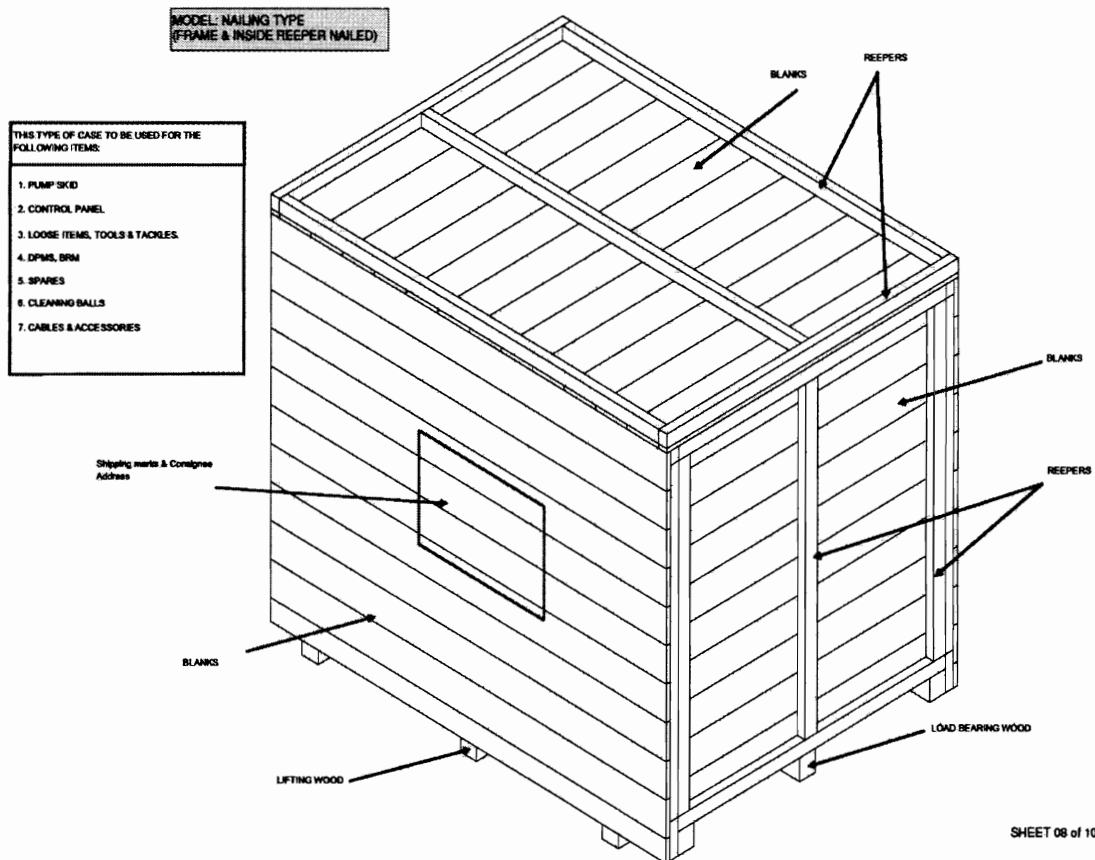

SHEET 08 of 10

	TITLE	SPECIFICATION NO. PE-TS-888-100-A001		
	TECHNICAL SPECIFICATION FOR SEAWORTHY PACKING FOR EXPORT JOBS	VOLUME II B		
		SECTION D		
		REV. NO. 0	DATE 10/08/2010	
		SHEET 37	OF	52

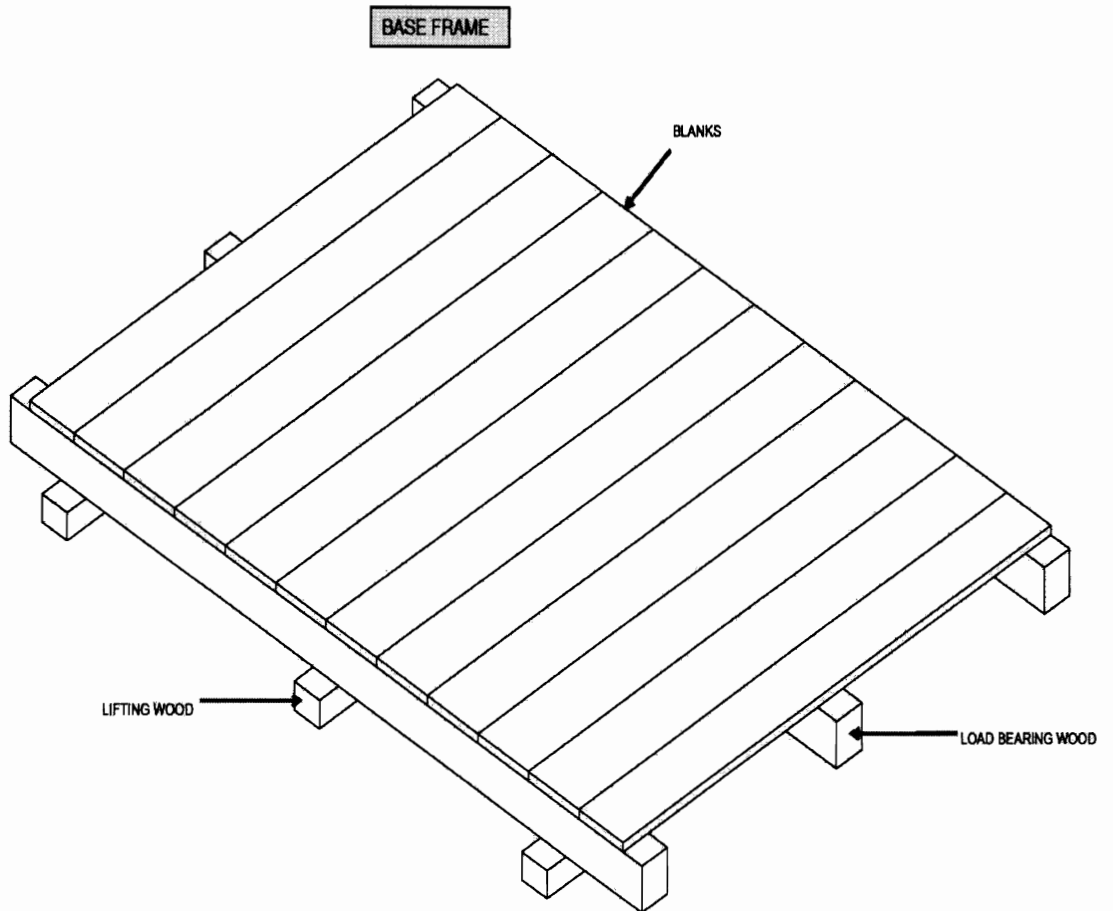

SHEET 09 of 10

	TITLE	SPECIFICATION NO. PE-TS-888-100-A001		
	TECHNICAL SPECIFICATION FOR SEAWORTHY PACKING FOR EXPORT JOBS	VOLUME II B		
		SECTION D		
		REV. NO. 0	DATE 10/08/2010	
		SHEET 38	OF	52

NAILING TYPE MODEL WITH TOP OPEN

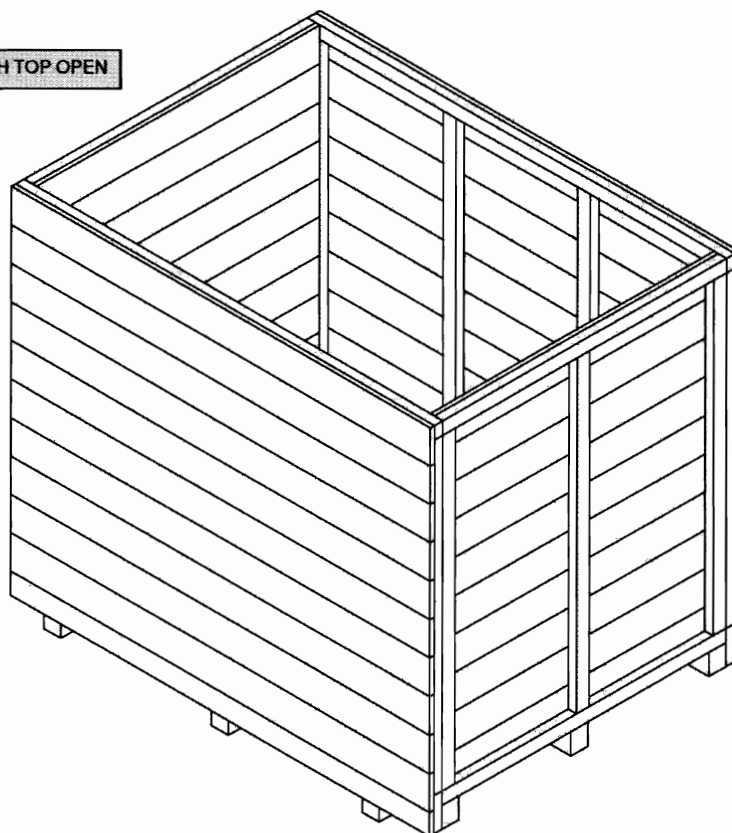

SHEET 10 of 10

	TITLE	SPECIFICATION NO. PE-TS-888-100-A001	
	TECHNICAL SPECIFICATION FOR SEAWORTHY PACKING FOR EXPORT JOBS	VOLUME II B	
		SECTION D	
		REV. NO. 0	DATE 10/08/2010
		SHEET 39	OF 52

10.4 PACKING OF LOOSE ITEMS

Loose mechanical, electrical and C&I items e.g. valves, fittings, pressure/temperature gauges/switches, circuit breakers, relays etc shall be individually wrapped using polyethylene sheets/U foam/ thermocol sheets/air bubble sheets depending upon the items and then packed in wooden boxes. The left out spaces and top of the boxes shall be filled with rubberized coir to get proper cushioning effect, Special attention shall be paid to relays, instruments etc for arresting the movements of their operating mechanism during transportation.

The construction of wooden packing cases shall be as per clause 9.3.1 retaining its all features concerning strength of the box. The construction of wooden packing case for electrical and C&I items shall be as per fig-16.

Inner surface of 6 sides of the box shall be lined with bitumen coated hessian polyethylene kraft paper. Rubberized coir of min. 25mm thickness and 100 mm width shall be nailed to inner surfaces of bottom and 4 sides of the boxes.

11.0 PACKING OF ELECTRICAL ITEMS

11.1 CABLES

11.1.1 **Type of Equipment**
All type of cables..

11.1.2 **Type of Construction**

New or practically new cable drums made of steel and painted with epoxy resin paint are to be used. Cable ends are carefully protected before packing. Over the cables polyethylene sheet shall be wrapped and then sealed properly. Cable drum can be put in wooden crates for ease in transportation and handling. (Wooden cable drum is also acceptable, however vendor to furnish constructional details for approval).

	TITLE	SPECIFICATION NO. PE-TS-888-100-A001		
	TECHNICAL SPECIFICATION FOR SEAWORTHY PACKING FOR EXPORT JOBS	VOLUME II B		
		SECTION D		
		REV. NO. 0	DATE 10/08/2010	
		SHEET 40	OF	52

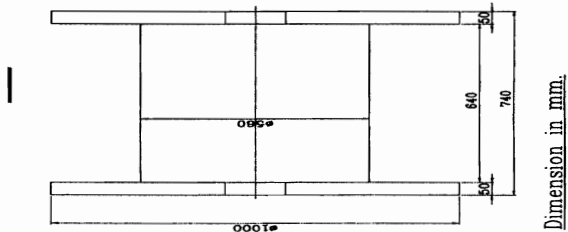
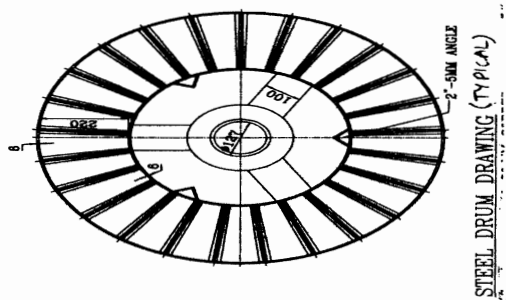

	TITLE	SPECIFICATION NO. PE-TS-888-100-A001	
	TECHNICAL SPECIFICATION FOR SEAWORTHY PACKING FOR EXPORT JOBS	VOLUME II B	
		SECTION D	
		REV. NO. 0	DATE 10/08/2010
		SHEET 41	OF 52

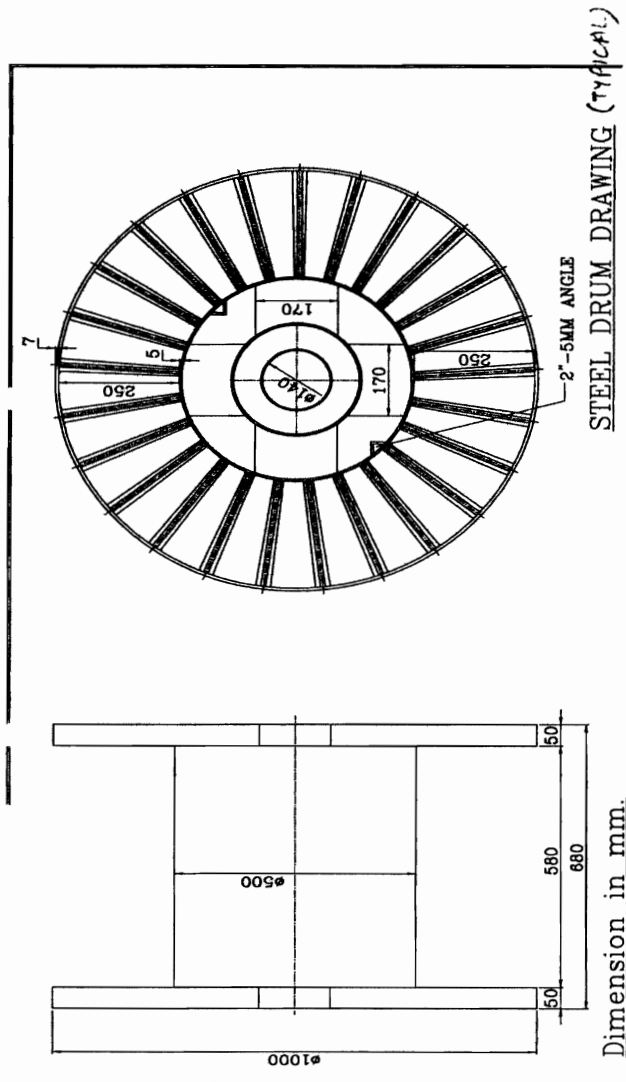

11.2 PACKING OF CABLE TRAYS & ACCESSORIES AND CABLE TRAY SUPPORT MATERIAL

11.2.1 Cable trays can be packed in wooden boxes as per fig 1 to 11 or in steel boxes. Details of steel box construction is as indicated below.

- 1) All Dimensions are in "mm" unless otherwise stated.
- 2) Packing Box shall be fabricated using 50x50x6mm MS Angle, 50x3mm Flat, 2.5 mm thick C Channel, 1mm & 1.6mm Thick sheet.
- 3) Finish of Packing Box Shall be Galvanized.
- 4) Angle & Channel Section forming part of the Main frame shall be welded thoroughly with each other to give a rigid structure.
- 5) Sheet Section and Flat section shall be bolted/ Riveted/ Welded suitably to the Main frame stated in '4' above.

	TITLE	SPECIFICATION NO. PE-TS-888-100-A001	
	TECHNICAL SPECIFICATION FOR SEAWORTHY PACKING FOR EXPORT JOBS	VOLUME II B	
		SECTION D	
		REV. NO. 0	DATE 10/08/2010
		SHEET 42	OF 52

- 6) Welding Portion on galvanized surfaces shall be painted with Zinc Rich Paint.
- 7) Dispatch details such as consignor/consignee address, contract and case details, 'country of origin, port of delivery, stacking instructions shall be written on one of the side of boxes. An anodized aluminium plate as per details and specifications given in page 3 of 5 shall be provided on the boxes
- 8) One copy of packing slip wrapped in polythylene bag covered with suitable aluminium .packing slip holder to be nailed on the external surface of the box. One more copy 9f the packing Slip wrapped in polythylene bag to be kept inside the box at the prominent place.
- 9) **INDICATION MARKS ON THE BOXES:** Markings shall be provided on the boxes indicating position of Boxes for handling, storage and nature of consignment. For guidelines referred page 4 of 5. The ink issued for this purpose as well as for marking dispatch instruction shall be indelible/non-washable marking ink.
- 10) Each item as mentioned in BOQ shall be packed & supplied as a set comprising of required numbers of associated fasteners & hardware etc

	TITLE	SPECIFICATION NO. PE-TS-888-100-A001	
	TECHNICAL SPECIFICATION FOR SEAWORTHY PACKING FOR EXPORT JOBS	VOLUME II B	
		SECTION D	
		REV. NO. 0	DATE 10/08/2010
		SHEET 43	OF 52

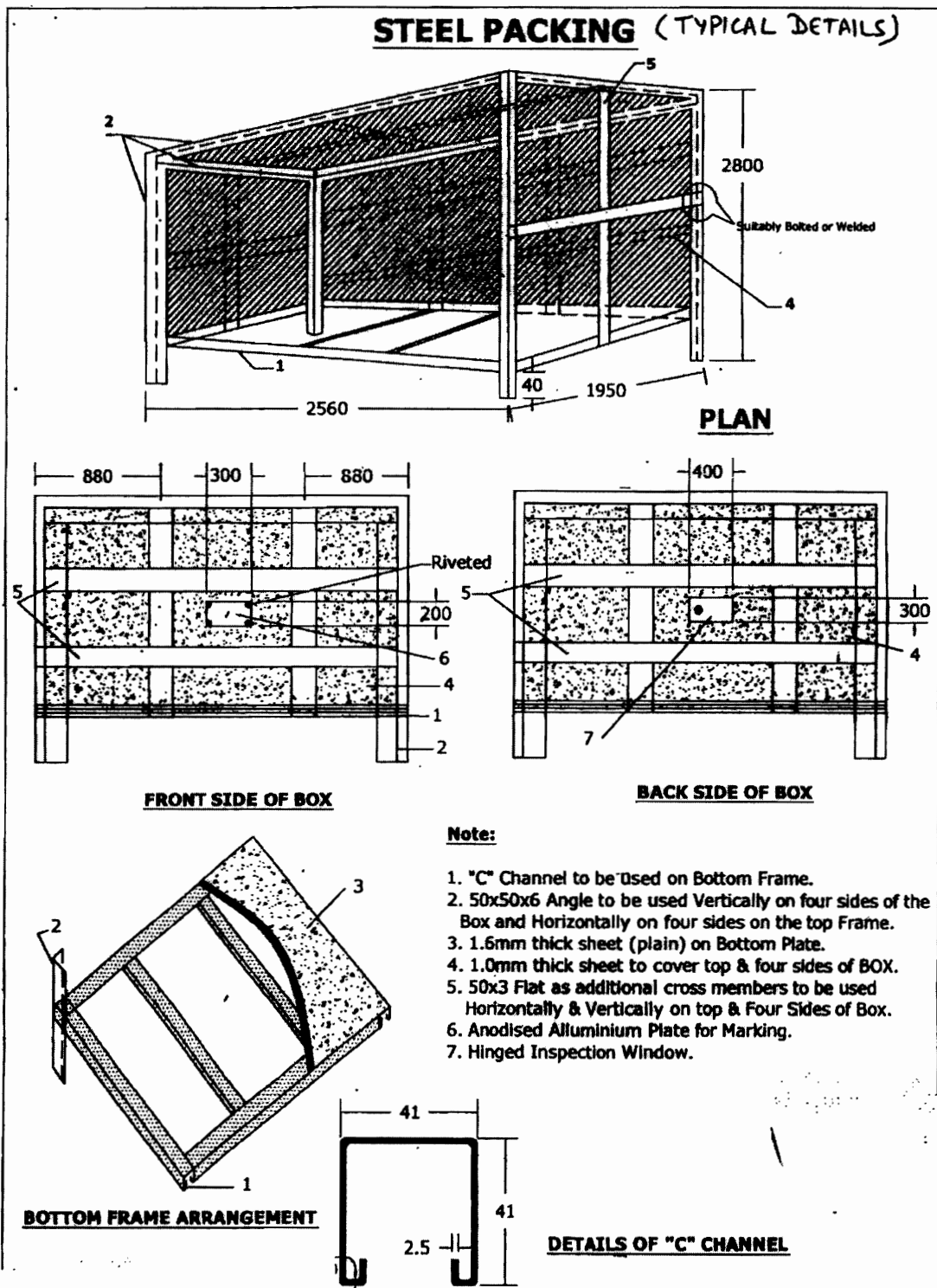

	TITLE	SPECIFICATION NO. PE-TS-888-100-A001	
	TECHNICAL SPECIFICATION FOR SEAWORTHY PACKING FOR EXPORT JOBS	VOLUME II B	
		SECTION D	
		REV. NO. 0	DATE 10/08/2010
		SHEET 44	OF 52

11.3 PACKING FOR STATION LIGHTING SYSTEM

Aspects of packing specific to equipments / items of station lighting system are given here. All other instructions / aspects as per the main specification of export packing which are not covered here shall also be applicable.

11.3.1 For LIGHTING TRANSFORMER, DISTRIBUTION BOARDS, LIGHTING PANELS,

- a) Construction of packing case for LIGHTING DISTRIBUTION BOARDS, LIGHTING PANELS, TRANSFORMER . shall be EITHER as per FIGURE 1,2,3,5,6,7,8,9,10,11 OR FIGURE 14,15,16.
- b) Each Panel/Transformer shall be individually covered with double polythene sheet of thickness 175 microns minimum.
- c) All the 6 inner surfaces of packing shall be nailed with bitumen coated hessian polythene craft paper. Wherever 2 pieces of craft paper are used, the joint shall have minimum overlap of 20mm.

For the top frame it shall be project on all sides by 100mm and shall be nailed on sides .

- d) The gap between the panels and packing case shall be filled with rubberized coir of thickness 50mm minimum and width 100mm. The distance between two consecutive supports of rubberized coir shall be less than 500mm.
- e) Silica get packed in cotton bags shall be placed at different positions inside the packing.
- f) Packing case shall be finally covered with GI sheet of thickness 0.4mm minimum.

11.3.2 For LUMINARIES, RECEPTACLES. EMERGENCY LIGHT, 240/24V TRANSFORMER, CEILING FAN, SWITCH BOARDS, FLEXIBLE CONDUIT, WIRES, EARTH WIRE. JUNCTION BOXES, ERECTION COMMISSIONING SPARES, RECOMMENDED SPARES , ERECTION MATERIAL AND CONSUMBALES

- a) Construction of packing case for THE ABOVE MATERIAL shall be as per FIGURE 1to11.
- b) Items placed inside the case shall be covered with double polythene sheet of thickness 175 microns minimum.
- c) All the 6 inner surfaces of packing shall be nailed with bitumen coated hessian craft paper. wherever 2 pieces of craft paper are used, the joint shall have minimum overlap of 20mm. For the top frame it shall be project on all sides by 100mm and shall be nailed on sides.
- d) Silica get packed in cotton bags shall be placed at different positions inside the packing.

11.3.3 For CONDUIT PIPE

As per international practice pipes are shipped in open bundles with metal strapping. Packing as per attached figure A shall be provided which is described as following:

- a) Each bundle shall be wrapped with 2 layers of 175 microns thick polythene sheet.
- b) Then bundle will be wrapped with bitumen coated hessian craft paper.
- c) Bundle shall be strapped with steel straps.
- d) An anodized aluminium packing description plate as per Figure No. 13 shall be provided.

11.3.4 For POLES

Poles will be wrapped with 2 layers of minimum 175 microns thick polythene sheet and then with bitumen coated hessian craft paper, packed as per Figure – C i.e. bundling.

11.3.5 For STRUCTURAL STEEL

	TITLE TECHNICAL SPECIFICATION FOR SEAWORTHY PACKING FOR EXPORT JOBS	SPECIFICATION NO. PE-TS-888-100-A001	
		VOLUME II B	
		SECTION D	
		REV. NO. 0	DATE 10/08/2010
		SHEET 45	OF 52

Structural steel will be different sizes and shapes. Hence it will be packed as per Figure No. B and described as following :

- a) Each bundle shall be wrapped with 2 layers of 175 microns thick polythene sheet.
- b) Then bundle will be wrapped with bitumen coated hessian craft paper.
- c) Bundle shall be strapped with steel straps.
- d) An anodized aluminium packing description plate as per Figure No. 13 shall be provided.

	TITLE	SPECIFICATION NO. PE-TS-888-100-A001	
	TECHNICAL SPECIFICATION FOR SEAWORTHY PACKING FOR EXPORT JOBS	VOLUME II B	
		SECTION D	
		REV. NO. 0	DATE 10/08/2010
		SHEET 46	OF 52

PACKING PROCEDURE FOR CONDUIT PIPE

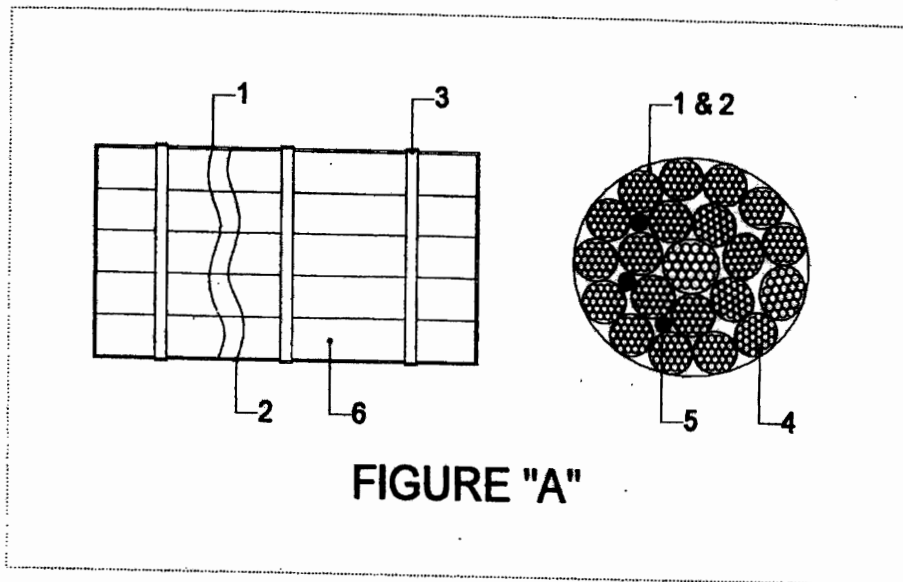



FIGURE "A"

- 1) LAYER OF BITUMEN COATED HESSIAN KRAFT PAPER.
- 2) LAYER OF POLYTHENE SHEET.
- 3) METAL STRAPPING.
- 4) CONDUIT PIPES.
- 5) SILICA GEL POUCHES.
- 6) BUNDLES OF CONDUIT PIPES.

	TITLE	SPECIFICATION NO. PE-TS-888-100-A001	
	TECHNICAL SPECIFICATION FOR SEAWORTHY PACKING FOR EXPORT JOBS	VOLUME II B	
		SECTION D	
		REV. NO. 0	DATE 10/08/2010
		SHEET 47	OF 52

PACKING PROCEDURE FOR STRUCTURAL STEEL

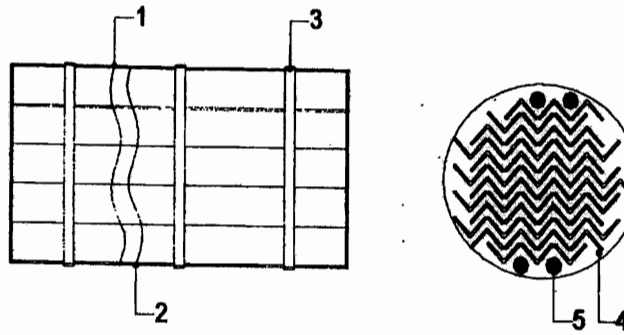

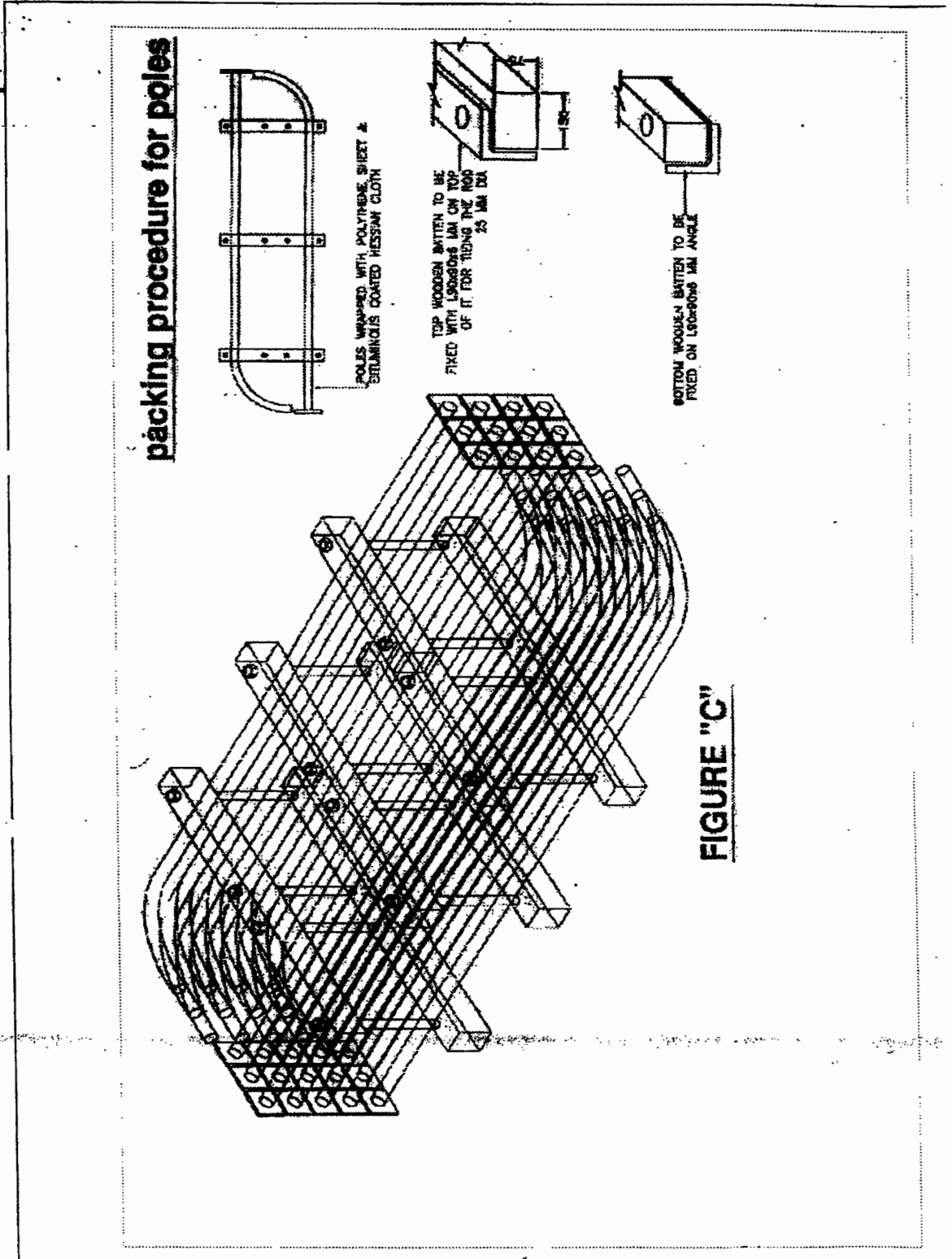



FIGURE "B"

- 1) LAYER OF BITUMEN COATED HESSIAN KRAFT PAPER.
- 2) LAYER OF POLYTHENE SHEET.
- 3) METAL STRAPPING.
- 4) STRUCTURAL STEEL.
- 5) SILICA GEL POUCHES.

	TITLE	SPECIFICATION NO. PE-TS-888-100-A001		
	TECHNICAL SPECIFICATION FOR SEAWORTHY PACKING FOR EXPORT JOBS	VOLUME II B		
		SECTION D		
		REV. NO. 0	DATE 10/08/2010	
		SHEET 48	OF	52



	TITLE	SPECIFICATION NO. PE-TS-888-100-A001	
	TECHNICAL SPECIFICATION FOR SEAWORTHY PACKING FOR EXPORT JOBS	VOLUME II B	
		SECTION D	
		REV. NO. 0	DATE 10/08/2010
		SHEET 49	OF 52

11.4 PACKING FOR DC BATTERY

The packing procedure for seaworthy packing of DC Battery is defined below, which is capable of withstanding impacts, compression, vibration, toppling, sea water spray, prevention against rust, temperature and extreme atmospheric conditions. Aspects of packing specific to equipments / items of DC Battery are given here. All other instructions / aspects as per the main specification of export packing which are not covered here shall also be applicable.

The packing procedure consists of various stages namely primary packing, cushioning, securing, desiccant, outside packing box, Runners/ sliders/ transverse bars of plywood, etc., provided for each movement.

- a) The packing boxes shall be made up of plywood boxes (thickness 9mm min.) with blocks at the bottom of the box for provision for handling the boxes using the forklift. The packing boxes sizes are generally standardized to half-euro size (capable of handling equipment's weight).
- b) Rubberized coir of 25mm thickness shall be provided as cushioning material at the bottom and thermocole of 20mm shall be provided inside on all four sides. Other than this polyethylene film wrap or cover also will be provided. Left out spaces to be filled with rubberized coir/ thermocol to get cushioning effect.
- c) Silica gel in dust free air permeable cotton/paper bag shall be placed in the packing boxes for storage period of 1 year as per IS 304 (1979)
- d) While packing the cells, transit caps (polypropylene) of red and blue shall be used for big size cells for ensuring that cells does not get damaged during the transport due to vibrations etc.
- e) The battery accessories shall be packed with suitable precautions as follows:
 - i) Copper connectors shall be packed after making bunches with lead wire seals to avoid misplacement.
 - ii) Hardware items shall be packed in polyethylene bags (Thickness ≥ 0.175 mm) with item slip
 - iii) Battery rack shall be packed in dismantled condition, wrapped with polyethylene sheet
 - iv) For Ni-Cd type battery, electrolyte in solid form for dry cells shall be packed in cans with KOH, LiOH being packed separately.
 - f) Galvanized Steel straps are provided for binding the packing box sides.
 - g) The handling instructions shall be marked in indelible/ non-washable ink, indicating the upright position.

11.5 PACKING OF SERVICE TRANSFORMERS(OIL FILLED) & ACCESSORIES

This instruction is applicable for packing of transformers (oil filled), its accessories and components so as to ensure safe delivery to end user. Aspects of packing specific to equipments / items of transformers(oil filled) are given here. All other instructions / aspects as per the main specification of export packing which are not covered here shall also be applicable.

11.5.01 PACKING DETAILS :

- a) Items shall be packed in case / crates as per the shipping list.
- b) All fragile items and small items shall be packed in cases and to be marked as "Fragile, handle with care Fragile items".
- c) Fragile accessories are to be first packed in their original boxes (VENDOR's packing). Very

	TITLE	SPECIFICATION NO. PE-TS-888-100-A001	
	TECHNICAL SPECIFICATION FOR SEAWORTHY PACKING FOR EXPORT JOBS	VOLUME II B	
		SECTION D	
		REV. NO. 0	DATE 10/08/2010
		SHEET 50	OF 52

- d small / delicate items such as glass thermometer, door keys shall be packed in separate box.
In case original box is found damaged, suitable alternate box or packing method using felt or foam sheet and polythene wrap to be used.
- e These boxes are then placed in identified wooden boxes. Inside of such boxes are lined with a layer of polythene sheet, packing wool / grass and another layer of polythene sheet before placing the boxes. All boxes are then wrapped with this polythene sheet before closing the box. Fragile items shall not be placed loose, one above the other inside the case.
- f All wiring cables, connection flats of non-ferrous materials, CTs, valves bellows shall also be packed.
- g Items like CTs, Oil communicating bushings, insulators, wired equipments and housings such as RTCC Panel, M. Box, Drive Mechanism, thermometers, gauges shall be wrapped in polythene from all around.
- h Buchholz relay and OSR relay openings will be blanked using covers, before putting them in the box
- i Items shall be carefully lowered and arranged inside the crate / case and each item shall be locked from all sides in such a way to avoid its movement in any way. Wooden stoppers and separators shall be provided for this and nailed to the crate / case wood.
- j Wooden planks and batons in contact with fragile items shall be provided with kit foam at the locations of contact.
- k Oil communication bushings shall be packed in separate case on V or U shape wooden felted supports, as in case of condenser bushings.
- l While placing and arranging the items inside the crates / cases, these shall be verified for correctness and then the packing note shall be signed. The cover top of the crate / case shall then be closed.
- m The main equipment like transformer tank shall be packed suitably to prevent any damage during transit / storage. Support structures like frame, header supports etc. shall be crated. Conservator headers shall also be crated. Radiators pipe work and other instruments & components shall be packed in cases. All the cases shall be lined with polythene from inside.

11.6 ALTERNATIVE PACKING CASES FOR CONTROL PANELS AND SWITCH GEARS

For Control and switch gear panels, construction of wooden packing cases may be provided as per fig 14 & 15 and as detailed below.

Thickness of planks for all sides, binding and jointing battens shall be at least 25 mm. Width of the plank shall be at least 125mm and that of binding and jointing planks shall be at least 100mm.

Top frame shall be suitable so that it does not collapse due to sandwiching between slings while lifting. Longitudinal and traverse bars for the bottom wooden pallet to be suitably selected.

Diagonal bracings shall be as per cl 9.3.1.3 and all other requirements shall be as per clauses 9.3.1.4 to 9.3.1.6.

12.0 Containerization

As required by BHEL, the VENDOR shall stuff the GOODS into 20 or 40 foot containers (dry, open top, flat racks, etc.).

The maximum inside dimensions of containers are to be considered:

	TITLE	SPECIFICATION NO. PE-TS-888-100-A001	
	TECHNICAL SPECIFICATION FOR SEAWORTHY PACKING FOR EXPORT JOBS	VOLUME II B	
		SECTION D	
		REV. NO. 0	DATE 10/08/2010
		SHEET 51	OF 52

- 40 foot containers: 11.80 m x 2.20 m x 2.05 m
- 20 foot containers: 5.80 m x 2.20 m x 2.05m
-

The present definition of containerization is valid for sea containers only. Vendor to check the size of containers before start of packing of equipment.

12.1 Protection of Cases/Crates

Since shipping containers are in general not water tight, packing in contact with the floor of the container shall be raised in order to prevent it from being damaged by the accumulation of water.

12.2 Mechanical Constraints

The mechanical constraints for "general use" closed containers are of a different nature (height of "stacking" being limited inside the containers), the packing for the GOODS may be of a lighter structure. However, it is necessary that the packing be appropriate so as to protect the GOODS on site during the storage period, as required after discharging of the GOOD'S from the containers.

Note:

It is the responsibility of the VENDOR to ensure that the cases/crates are stowed, secured and fastened inside the container. The VENDOR will take all necessary precautions to conform to the maximum weight allowed and the centre of gravity of the container. The securing and fastening of the cases/ crates can be carried out by nailing timbers on the bottom or on the vertical sides of the container.

13.0 Other Services to be provided by Vendor

In addition to the packing and shipping documents, VENDOR must also carry out the following services, which shall be included in his quotation:

Carriage of VENDOR's sub-contracted equipment and material, which must be re-grouped in VENDOR's or PACKER's workshops, whilst waiting for packaging.

BHEL reserves the right to postpone the shipping of the GOODS. In this event, any storage and insurance costs during the first ninety (90) days shall be borne by the VENDOR.

Loading, including lifting, securing, lashing, and stowing, of all cases, crates, or packages onto means of transportation such as, but not limited to, trailers, containers, etc.

14.0 Responsibilities and Guarantees

VENDOR is responsible for the choice of category for packing according to the transport facilities used, and on the basis of the present document. In case of doubt or disagreement regarding the choice, VENDOR must inform BHEL prior to packing and await BHEL's approval. All phases of packaging, marking, loading, etc. will be subject to BHEL inspection.

BHEL reserves the right to reject the packing when the packing does not conform to these instructions and/or when the packing does not ensure perfect protection of the GOODS. VENDOR is responsible for the weights and dimensions declared, and the marking of the packages.

The documents must be in strict conformity with the packing contents.

The packing specified in these "Packing, Marking and Shipping Instructions" is guaranteed for a twelve (12) months storage period after delivery on site.

VENDOR is responsible for providing storage recommendation adapted to the GOODS. According to this guarantee, VENDOR is held responsible in the event of goods becoming

	TITLE	SPECIFICATION NO. PE-TS-888-100-A001	
	TECHNICAL SPECIFICATION FOR SEAWORTHY PACKING FOR EXPORT JOBS	VOLUME II B	
		SECTION D	
		REV. NO. 0	DATE 10/08/2010
		SHEET 52	OF 52

useless, damaged or broken, as a result of poor packing and/or stowing, or due to corrosion, subsequent to insufficient or inadequate protection. All direct or indirect costs resulting thereof, will be back-charged to VENDOR.

788226/2022/PS-PEM-MAX

PEM-6666-0



TITLE 2X660 MW BIFPCL MAITREE

TECHNICAL SPECIFICATION

FOR

WORKSHOP EQUIPMENT

SPECIFICATION NO. PE – TS - 421 - 568 – A008B

SECTION I

SUB SECTION IB

REV 0

SHEET OF

SECTION – IB

Specific Technical Requirement (Electrical)

**BANGLADESH-INDIA FRIENDSHIP POWER
COMPANY (PVT.) LIMITED, BANGLADESH**

**2X660 MW MAITREE SUPER THERMAL POWER
PROJECT**

WORKSHOP EQUIPMENT

**TECHNICAL SPECIFICATION
(ELECTRICAL PORTION)**

788226/2022/PS-PEM-MAX



ELECTRICAL EQUIPMENT SPECIFICATION
FOR
WORKSHOP EQUIPMENT
2X660 MW MAITREE SUPER THERMAL POWER
PROJECT

SPECIFICATION NO.

VOLUME NO. : **II-B**SECTION: **I**REV NO. : **00** DATE: 12/02/2018SHEET: **1** OF **2**

CONTENTS

SECTION	TITLE	NO OF SHEETS
I	SPECIFIC TECHNICAL REQUIREMENTS	1
I	ELECTRICAL SCOPE BETWEEN BHEL & VENDOR	1
I	ELECTRICAL LOAD DATA	1
II	MOTOR DATASHEET-A	1
II	MOTOR DATASHEET-C	5
II	QUALITY PLAN (FOR MOTORS 55 KW & ABOVE)	9



**ELECTRICAL EQUIPMENT SPECIFICATION
FOR
WORKSHOP EQUIPMENT
2X660 MW MAITREE SUPER THERMAL POWER
PROJECT**

SPECIFICATION NO.

VOLUME NO. : **II-B**SECTION: **I**REV NO. : **00** DATE: 12/02/2018SHEET: **2** OF **2**

SPECIFIC TECHNICAL REQUIREMENTS: ELECTRICAL

1.0 EQUIPMENT & SERVICES TO BE PROVIDED BY BIDDER:

- a) Services and equipment as per "Electrical Scope between BHEL and Vendor".
- b) Any item/work either supply of equipment or erection material which have not been specifically mentioned but are necessary to complete the work for trouble free and efficient operation of the plant shall be deemed to be included within the scope of this specification. The bidder without any extra charge shall provide the same.
- c) Supply of mandatory spares as specified in the specifications of mechanical equipment's.
- d) Electrical load requirement for WORKSHOP EQUIPMENT.
- e) All equipment shall be suitable for the power supply fault levels and other climatic conditions mentioned under part B0 of FICHTNER Technical Specification.
- f) Various drawings, data sheet as per required format, quality plans, calculations, Type test & Routine test reports & certificates, operation and maintenance manuals, complete technical literature with catalogues etc. shall be furnished as specified at contract stage. All documents shall be subject to customer /BHEL approval without any commercial implications to BHEL.
- g) The sub-vendor list for various electrical items is subject to BHEL/Customer approval without any commercial implications. However, bidder to note that sub-vendor list attached with the specification is only indicative & shall be finalized with L1 bidder before placement of LOI.

2.0 EQUIPMENT & SERVICES TO BE PROVIDED BY PURCHASER FOR ELECTRICAL & TERMINAL POINTS:

Refer "Electrical Scope between BHEL and Vendor".

3.0 DOCUMENTS TO BE SUBMITTED ALONG WITH BID

- 3.1 The electrical specification without any deviation from the technical/quality assurance requirements stipulated shall be deemed to be complied by the bidder in case bidder furnishes the overall compliance of package technical specification in the form of compliance certificate/No deviation certificate.
- 3.2 No technical submittal such as copies of data sheets, drawings, write-up, quality plans, type test certificates, technical literature, etc, is required during tender stage. Any such submission even if made, shall not be considered as part of offer.

STANDARD ELECTRICAL SCOPE BETWEEN BHEL AND VENDOR (FOR EPC PROJECTS) REV-0, DATE: 12.02.2018

PACKAGE : WORKSHOP EQUIPMENT
SCOPE OF VENDOR: SUPPLY
PROJECT : 2X660 MW MAITREE SUPER THERMAL POWER PROJECT

S.NO	DETAILS	SCOPE SUPPLY	SCOPE E&C	REMARKS
1	Power Supply	BHEL	BHEL	240 V AC (supply feeder)/415 V AC (3 PHASE 4 WIRE) supply shall be provided by BHEL based on load data provided by vendor at contract stage for all equipment supplied by vendor as part of contract. Any other voltage level (AC/DC) required will be derived by the vendor.
2	Motors	Vendor	Vendor	

NOTES:

1. Make of all electrical equipment/ items supplied shall be reputed make & shall be subject to approval of BHEL/customer after award of contract without any commercial implication.
2. All QPs shall be subject to approval of BHEL/customer after award of contract without any commercial implication.

LV MOTORS

DATA SHEET-A

SPECIFICATION NO.

VOLUME II B

SECTION II

REV NO. 00 DATE 12.02.2018

SHEET 1 OF 1

- 1.0 Design ambient temperature : 45 °C
- 2.0 Maximum acceptable kW rating of LV motor : <160KW
- 3.0 Installation (Indoors/ Outdoors) : As required
- 4.0 Degree of Protection : IP55
- 5.0 Type of Cooling : TEFC/CACA/TETV
- 6.0 Details of supply system
- a) Rated voltage (with variation) : 415V ± 10%
- b) Rated frequency (with variation) : 50 Hz (Variation: +4% TO -6%)
- c) Combined voltage & freq. variation : 10%
- d) System fault level at rated voltage : 50 kA for 1 sec
- e) Short time rating for terminal boxes
- o 90kW & Above : 50 kA for 1 sec
(Breaker controlled)
- o Below 90kW (SFU/MCCB+: Contactor controlled) : 50 kA for 0.20 sec.
- f) LV System grounding : Solidly
- 7.0 Class of insulation : Class 'F', with temp rise limited to class B.
- 8.0 Minimum voltage for starting (As percentage of rated voltage) : 80% of rated voltage
- 9.0 Power cables data : Shall be given during detailed engg.
- 10.0 Earth Conductor Size & Material : Shall be given during detailed engg.
- 11.0 Space heater supply : 240 V, 1Φ, 50 Hz
- 12.0 Rating up to which Single phase motor : Acceptable below 0.20 kW
- 13.0 Tests : As per motor spec. (enclosed)
- 14.0 Energy efficient/ Flame proof motor : Continuous duty LT motors up to 160 KW Output rating (At 45 deg.C ambient temperature), shall be Premium Efficiency class-IE3

- For further detailing please refer specification B0- "General Technical Specification"

CLAUSE NO.	Bidder's Name		
	DE-	LT MOTORS	
	A.	GENERAL	
	1.	Manufacturer & Country of origin. (Shall be as per approved QA make)	
	2.	Equipment driven by motor	
	3.	Motor type	
	4.	Quantity	
	B.	DESIGN AND PERFORMANCE DATA	
	1.	Frame size	
	2.	Type of duty	
	3.	Type of enclosure /Method of cooling/ Degree of	
	4.	Applicable standard to which motor generally	
	5.	Efficiency class as per IS	
	6.	(a)Whether motor is flame proof	Yes/No
		(b)If yes, the gas group to which it conforms as per	
	7.	Type of mounting	
	8.	Direction of rotation as viewed from DE END	
	9.	Standard continuous rating at 40 deg.C. ambient temp. as per Indian Standard (KW)	
	10.	Derated rating for specified normal condition i.e. 50 deg. C ambient temperature (KW)	
	11.	Maximum continuous load demand of driven	
	12.	Rated Voltage (volts)	
	13.	Permissible variation of :	
		a. Voltage (Volts)	
		b. Frequency (Hz)	
		c. Combined voltage and frequency	
	14.	Rated speed at rated voltage and	
	15.	At rated Voltage and frequency:	
		a. Full load current	

CLAUSE NO.	Bidder's Name	
		b. No load current
16.	Power Factor at	
	a. 100% load	
	b. NO load	
	c. Starting.	
17.	Efficiency at rated voltage and frequency,	
	a. 100% load	
	b. 75% load	
	c. 50% load	
18.	Starting current (amps) at	
	a. 100 % voltage	
	b. 85% voltage	
	c. 80% voltage	
19.	Minimum permissible starting Voltage (Volts)	
20.	Starting time with minimum permissible voltage	
	a. Without driven equipment coupled	
	b. With driven equipment coupled	
21.	Safe stall time with 100% and 110% of rated	
	a. From hot condition	
	b. From cold condition	
22.	Torques :	
	a. Starting torque at min. permissible voltage(kg-	
	b. Pull up torque at rated voltage.	
	c. Pull out torque	
	d. Min accelerating torque (kg.m) available	
	e. Rated torque (kg.m)	
23.	Stator winding resistance per phase (ohms at 20	
24.	GD2 value of motors	

CLAUSE NO.	Bidder's Name	
	25.	No of permissible successive starts when motor is in hot condition
	26.	Locked Rotor KVA Input
	27.	Locked Rotor KVA/KW
	28.	Vibration limit :Velocity (mm/s)
	29.	Noise level limit (dBA)
	C.	CONSTRUCTIONAL FEATURES
	1.	Stator winding insulation
		a. Class & Type
		b. Winding Insulation Process
		c. Tropicalised (Yes/No)
		d. Temperature rise over specified maximum ambient temperature of 50 deg C
		e. Method of temperature measurement
		f. Stator winding connection
	2.	Main Terminal Box
		a. Type
		b. Location(viewed from NDE side)
		c. Entry of cables(bottom/side)
		d. Recommended cable size(To be matched with cable size envisaged by owner)
		e. Fault level (MVA),Fault level duration(sec)
		f. Cable glands & lugs details (shall be suitable for
	3.	Type of DE/NDE Bearing
	4.	Motor Paint shade
	5.	Weight of
		a. Motor stator (KG)
		b. Motor Rotor (KG)
		c. Total weight (KG)

CLAUSE NO.	Bidder's Name	
	D.	List of accessories.
	1.	Space Heaters (Applicable for 30 KW & above motor) (Nos./Power in watts/supply voltage)
	2.	Terminal Box for Space Heater (Yes/No)
	3.	Speed switch (Yes/No)
	4.	Insulation of bearing (Yes/No)
	5.	Noise reducer(Yes/No)
	6.	Grounding pads
		i) No and size on motor body
		ii) Nos on terminal Box
	7.	Vibration pads
		i) Nos and size
		ii) Location
	8.	Any other fitments
	E.	List of curves.
	1.	Torque speed characteristic of the motor
	2.	Thermal withstand characteristic
	3.	Starting. current Vs. Time
	4.	Starting. current Vs speed
	5.	P.F. and Effi. Vs Load
	F.	Additional Data to be filled for each rating of DC Motor
	1.	Rated armature voltage (Volt)
	2.	Rated field excitation (Amp)
	3.	Permissible % variation in voltage
	4.	Minimum Permissible Starting voltage (volt)
	5.	At rated voltage
		i)Full load Armature current.(Amp)

CLAUSE NO.	Bidder's Name	
	ii) Full load Field current (Amp)	
	iii) No load Armature current (Amp)	
6.	Full load Field current (Amp)	
7.	No load Armature current (Amp)	
8.	Minimum permissible field current (Amp) to avoid	
	i) Maximum permissible voltage	
	ii) Rated voltage	
	iii) Minimum Permissible Voltage	
9.	Resistance (indicative Values) in ohm	
	i) Armature winding (Arm + IP + Series) at 25	
	ii) Field Winding at 25 deg. C	
10..	Inductance (indicative values)	
	i) Armature winding	
	ii) Field winding	
11	Value of trimmer resistance (ohm) to be connected in series with the shunt field to	
	i) 220 V DC	
	ii) 250 V DC	
	iii) 187 V DC	
12	Value of the external resistance (ohm) required to be connected in series with armature during starting only	
13	Technical data sheet for external resistance box	
14	GA drawing of motor	
15	Starting time calculation	
16	Starter resistance design calculation	
17	Electrical connection diagram of motor	

CUSTOMER :		PROJECT		SPECIFICATION :							
BIDDER/ VENDOR SYSTEM		TITLE		NUMBER :							
QUALITY PLAN		QUALITY PLAN		SPECIFICATION :							
SHEET 1 OF 9		NUMBER PED-506-00-Q-007_REV-03		TITLE							
SL. NO.	COMPONENT/OPERATION	CHARACTERISTIC CHECK	CAT.	TYPE/METHOD OF CHECK	EXTENT OF CHECK	REFERENCE DOCUMENT	ACCEPTANCE NORM	FORMAT OF RECORD	SECTION	REMARKS	
										P	W
1	2	3	4	5	6	7	8	9	10	11	
1.0	RAW MATERIAL & BOUGHT OUT CONTROL		MA	VISUAL	100%	-	FREE FROM BLINKS, CRACKS, WAVINESS ETC	LOG BOOK	3	-	
1.1	SHEET STEEL, PLATES, SECTION, EYEBOLTS	1.SURFACE CONDITION 2.DIMENSIONS 3.PROOF LOAD TEST (EYE BOLT)	MA	MEASUREMENT	SAMPLE	MANFR'S DRG./SPEC	MANFR'S DRG./SPEC	-DO-	3	-	
1.2	HARDWARES	1.SURFACE CONDITION 2.PROPERTY CLASS	MA	MECH. TEST	-DO-	-DO-	-DO-	INSPEC. REPORT	3	-	2
1.3	CASTING	1.SURFACE CONDITION 2.CHEM. & PHY. PROP. 3.DIMENSIONS	MA	VISUAL	100%	MANFR'S DRG./SPEC BOOK	FREE FROM CRACKS, UNEVENNESS ETC. RELEVENT IEC STANDARD/SPEC	SUPPLIERS TC & LOG	3	-	2
1.4	PAINT & VARNISH	1.MAKE SHADE, SHELF LIFE & TYPE	MA	CHEM & MECH TEST	1/HEAT NO.	MANFR'S DRG./SPEC	FREE FROM CRACKS, BLOW HOLES ETC. RELEVENT IEC STANDARD	SUPPLIER'S TC	3	-	2
			MA	MEASUREMENT	100%	MANUFRR'S DRG.	MANUFRR'S DRG.	LOG BOOK	3	-	2
			MA	VISUAL	100% CONTINUOUS	MANFR'S DRG./SPEC	MANFR'S DRG./SPEC	LOG BOOK	3	-	2
BHEL		PARTICULARS		BIDDER/VENDOR							
		NAME									
		SIGNATURE									
		DATE									
										BIDDER/ VENDORS COMPANY SEAL	

		CUSTOMER :				PROJECT :				SPECIFICATION :		
		BIDDER/ VENDOR SYSTEM				TITLE				NUMBER :		
QUALITY PLAN		NUMBER PED-506-00-Q-007, REV-03				TITLE				SPECIFICATION :		
SHEET 2 OF 9		ITEM: AC ELECT. MOTORS 55 KW & ABOVE (LV & MV)				SECTION				VOLUME III		
SL. NO.	COMPONENT/OPERATION	CHARACTERISTIC CHECK	CAT.	TYPE/METHOD OF CHECK	EXTENT OF CHECK	REFERENCE DOCUMENT	ACCEPTANCE NORM	FORMAT OF RECORD	AGENCY	REMARKS		
1	2	3	4	5	6	7	8	9	P	W	V	
1.5	SHAFT (FORGED OR ROLLED)	1. SURFACE COND. 2. CHEM. & PHYSICAL PROPERTIES 3. DIMENSIONS 4. INTERNAL FLAWS	MA	VISUAL	100%	-	FREE FROM VISUAL DEFECTS	-DO-	3	-	-	VENDOR'S APPROVAL IDENTIFICATION SHALL BE MAINTAINED
1.6	SPACE HEATERS, CONNECTORS, TERMINAL BLOCKS, CABLES, CABLE LUGS, CARBON BRUSH TEMP. DETECTORS, RTD, BTD'S	1. MAKE & RATING 2. PHYSICAL COND. 3. DIMENSIONS (WHEREVER APPLICABLE) 4. PERFORMANCE/ CALIBRATION	MA	CHEM. & PHYSICAL TESTS	1/HEAT NO. OR HEAT TREATMENT BATCH NO	MFG. DRG. SPEC.	RELEVANT IEC STANDARD	SUPPLIER'S TC	3	-	2	
			MA	MEASUREMENT	100%	-DO-	MANUF'R'S DRG.	LOG BOOK	3	-	2	
			CR	UT	-DO-	ASTM-A388	MANUF'R'S SPEC. BHEL SPEC.	-DO-	3	2	1	FOR DIA OF 55 MM & ABOVE
			MA	VISUAL	-DO-	MANUF'R'S DRG. SPEC.	MANUF'R'S DRG. SPEC.	-DO-	3	-	2	
			MA	-DO-	-DO-	-	NO PHYS. DAMAGE, NO ELECTRICAL DISCONTINUITY	-DO-	3	-	2	
			MA	MEASUREMENT	SAMPLE	MANUF'R'S DRG./ SPEC.	MANUF'R'S DRG./ SPEC.	-DO-	3	-	2	
			MA	TEST	100%	-DO-	-DO-	INSP. REPORT	3	-	2	
BHEL			PARTICULARS			BIDDER/VENDOR						
			NAME									
			SIGNATURE									
			DATE									
											BIDDER'S/VENDORS COMPANY SEAL	

		QUALITY PLAN		CUSTOMER :			PROJECT TITLE			SPECIFICATION :			
		SHEET 3 OF 9		BIDDER/ VENDOR	SYSTEM CAT.	TYPE/ METHOD OF CHECK	EXTENT OF CHECK	REFERENCE DOCUMENT	ACCEPTANCE NORM	FORMAT OF RECORD	AGENCY	SECTION	NUMBER :
SL. NO.	COMPONENT/OPERATION	CHARACTERISTIC CHECK	4	5	6	7	8	9	P	W	V	TITLE	VOLUME III REMARKS
1	2	3	4	5	6	7	8	9	10	11			
1.7	OTHER INSULATING MATERIALS LIKE SLEEVES, BINDINGS CORDS, PAPERS, PRESS BOARDS ETC.	1. SURFACE COND. ETC. 2. OTHER CHARACTERISTICS	MA	VISUAL	100%	-	NO VISUAL DEFECTS	INSPT. REPORT	3	-	2		
1.8	SHEET STAMPING (PUNCHED)	1. SURFACE COND. 2. DIMENSIONS INCLUDING BURS HEIGHT 3. ACCEPTANCE TESTS	MA	TEST	SAMPLE	MANUF'S SPEC.	MANUF'S SPEC.	LOG BOOK AND OR SUPPLIER'S TC	3	-	2		
1.9	CONDUCTORS	1. SURFACE FINISH 2. ELECT. PROP. & MECH. PROP	MA	VISUAL	100%	MANUF'S DRG.	MANUF'S DRG.	LOG BOOK	3	-	2		FOR MV MOTOR INSULATION/VARNISH THICKNESS SHALL BE MORE THAN THE BURS HEIGHT
			MA	ELECT. & MECH TESTS	-DO-	MANUF'S SPEC./ RELEVANT IEC STANDARD	RELEVANT IEC STANDARD	SUPPLIER'S TC	3	-	2		
			MA	VISUAL	100%	-	FREE FROM VISUAL DEFECTS	LOG BOOK	3*	-	2*		* MOTOR MANUFACTURER TO CONDUCT VISUAL CHECK FOR SURFACE FINISH ON RANDOM BASIS (10% SAMPLE) AT HIS WORKS AND MAINTAIN RECORD FOR VERIFICATION BY BHEL/CUSTOMER.
			MA	ELECT. & MECH. TEST	SAMPLES	RELEVANT IEC OR OTHER STANDARDS	RELEVANT IEC OR OTHER STANDARDS	SUPPLIER'S TC & VENDOR'S INSPN. REPORTS	3	-	2		
BHEL													
			PARTICULARS			BIDDER/VENDOR							
			NAME										
			SIGNATURE										
			DATE										
BIDDER'S/VENDORS COMPANY SEAL													

		CUSTOMER :				PROJECT :				SPECIFICATION :		
		BIDDER/ VENDOR SYSTEM				TITLE				NUMBER :		
QUALITY PLAN		NUMBER PED-506-00-Q-007, REV-03				TITLE				SPECIFICATION :		
SHEET 4 OF 9		ITEM: AC ELECT. MOTORS 55 KW & ABOVE (LV & MV)				SECTION				VOLUME III		
SL. NO.	COMPONENT/OPERATION	CAT.	TYPE/METHOD OF CHECK	EXTENT OF CHECK	REFERENCE DOCUMENT	ACCEPTANCE NORM	FORMAT OF RECORD	AGENCY	REMARKS	P	W	V
1		4	5	6	7	8	9	10	11			
1.10	BEARINGS	MA	MEASUREMENT	-DO-	-DO-	-DO-	Log Book	3	-	2		
	3.DIMENSIONS				MANFR'S DRG./ APPROVED DATASHEET	MANFR'S DRG./ APPROVED DATASHEET	-DO-	3	-	2		
	1.MAKE & TYPE & MODEL	MA	VISUAL	100%		FREE FROM VISUAL DEFECTS	-DO-	3	-	2		
	2.SURFACE FINISH	MA	VISUAL	100%		-DO-	-DO-	3	-	2		
1.11	SLIP RING (WHEREVER APPLICABLE)	MA	VISUAL	100%		-DO-	-DO-	3	-	-		
	1.SURFACE COND.	MA	MEASUREMENT	SAMPLE	MANUF'S DRG	MANUF'S DRG	-DO-	3	-	-		
	2.DIMENSIONS	MA	MEASUREMENT	SAMPLE	MANUF'S DRG	MANUF'S DRG	-DO-	3	-	-		
	3.TEMP.WITH-STAND CAPACITY	MA	ELECT.TEST	-DO-	MANUF'S SPEC./BHEL SPEC.	MANUF'S SPEC./BHEL SPEC.	-DO-	3	-	2		
	4.HV/IR	MA	-DO-	100%		-DO-	-DO-	3	-	2		
1.12	OIL SEALS & GASKETS	MA	VISUAL	100%		MANUF'S DRG./ SPECS.	-DO-	3	-	-		
	1.MATERIAL OF GASKET	MA	VISUAL	100%		MANUF'S DRG./ SPECS.	-DO-	3	-	-		
	2.SURFACE COND.	MA	VISUAL	100%		FREE FROM VISUAL DEFECTS	-DO-	3	-	-		
	3.DIMENSIONS	MA	MEASUREMENT	SAMPLE	MANUF'S DRG	MANUF'S DRG	-DO-	3	-	-		
BHEL		PARTICULARS		BIDDER/VENDOR								
		NAME										
		SIGNATURE										
		DATE										
												BIDDER'S/VENDORS COMPANY SEAL

		QUALITY PLAN		CUSTOMER :			PROJECT			SPECIFICATION :						
		SL. NO.	COMPONENT/OPERATION	SHEET 5 OF 9	CHARACTERISTIC CHECK	BIDDER/ VENDOR	SYSTEM CAT.	TYPE/ METHOD OF CHECK	EXTENT OF CHECK	REFERENCE DOCUMENT	ACCEPTANCE NORM	FORMAT OF RECORD	AGENCY	SECTION	TITLE	NUMBER :
		2	3	4	5	6	7	8	9	10	11	P	W	V	REMARKS	
1	IN PROCESS			MA	VISUAL	100%	-DO-	GOOD FINISH	LOG BOOK			3/2	2	-		
2.0	STATOR FRAME WELDING (IN CASE OF FABRICATED STATOR)	1.WORKMANSHIP & CLEANNESS		MA	MEASUREMENT	-DO-	MANUF'S DRG	MANUF'S DRG	-DO-			2	-	-		
2.1	MACHINING	1.FINISH		MA	VISUAL	100%	-DO-	GOOD FINISH	LOG BOOK			2	-	-		
2.2		2.DIMENSIONS		MA	MEASUREMENT	-DO-	MANUF'S DRG	MANUF'S DRG	-DO-			2	-	-		
2.3	PAINING	3.SHAFT SURFACE FLOWS		MA	PT	-DO-	RELEVANT SPEC./ ASTM-E165	MANUF'S SPEC./ BHEL SPEC./	-DO-			2	-	1		
		1.SURFACE PREPARATION		MA	VISUAL	100%	MANFR'S SPEC/BHEL SPEC/ RELEVANT STAND	BHEL SPEC. SAME AS COL.7	LOG BOOK			2	-	-		
		2.PAINT THICKNESS (BOTH PRIMER & FINISH COAT)		MA	MEASUREMENT BY ELCOMETER	SAMPLE	-DO-	-DO-	-DO-			2	-	-		
		3.SHADE		MA	VISUAL	-DO-	-DO-	-DO-	Log Book			2	-	-		
		4.ADHESION		MA	CROSS CUTTING & TAPE TEST	-DO-	-DO-	-DO-	Log Book			2	-	-		
BHEL																
PARTICULARS												BIDDER/VENDOR				
NAME																
SIGNATURE																
DATE																
															BIDDER'S/VENDORS COMPANY SEAL	

		QUALITY PLAN		CUSTOMER :			PROJECT TITLE			SPECIFICATION :		
		SHEET 6 OF 9		BIDDER/ VENDOR	SYSTEM CAT.	TYPE/ METHOD OF CHECK	EXTENT OF CHECK	REFERENCE DOCUMENT	ACCEPTANCE NORM	FORMAT OF RECORD	SECTION AGENCY	REMARKS
SL. NO.	COMPONENT/OPERATION	CHARACTERISTIC CHECK	3	4	5	6	7	8	9	10	VOLUME III	TITLE
1	2											
2.4	SHEET STACKING	1.COMPLETENESS 2.COMPRESSION & TIGHTENING 3.CORE LOSS & HOTSPOT	MA	MEASUREMENT	SAMPLE	MANUF'R'S SPEC.	MANUF'R'S SPEC.	MANUF'R'S SPEC.	Log Book	2	-	
			MA	MEASUREMENT	100%	-DO-	-DO-	-DO-	Log Book	2	-	
			MA	ELECT. TEST	-DO-	-DO-	-DO-	-DO-	Log Book	2	1*	(FOR MOTORS OF 2MW AND ABOVE) * ON 10% RANDOM SAMPLE
2.5	WINDING	1.COMPLETENESS 2.CLEANLINESS 3.IR-HV/IR 4.RESISTANCE 5.INTERTURN INSULATION 6.SURGE WITH STAND AND TAN DELTA TEST	CR	VISUAL	100%	MANUF'R'S SPEC./BHEL SPEC.	MANUF'R'S SPEC./BHEL SPEC.	MANUF'R'S SPEC./BHEL SPEC.	Log Book	2	-	
			CR	-DO-	-DO-	-DO-	-DO-	-DO-	Log Book	2	-	
			CR	ELECT. TEST	-DO-	-DO-	-DO-	-DO-	Log Book	2	-	
			CR	-DO-	-DO-	-DO-	-DO-	-DO-	Log Book	2	-	
			CR	-DO-	-DO-	-DO-	-DO-	-DO-	Log Book	2	-	
			CR	-DO-	-DO-	-DO-	-DO-	-DO-	Log Book	2	-	FOR MV MOTOR
2.6	IMPREGNATION	1.VISCOSITY 2.TEMP. PRESSURE VACUUM 3.NO. OF DIPS (NOT APPLICABLE IN CASE OF VPI)	MA	PHY. TEST	AT STARTING	-DO-	-DO-	-DO-	Log Book	2	-	
			MA	PROCESS CHECK	CONTINUOUS	-DO-	-DO-	-DO-	Log Book	2	-	
			MA	-DO-	-DO-	-DO-	-DO-	-DO-	Log Book	2	-	THREE DIPS TO BE GIVEN
BHEL												
PARTICULARS												
BIDDER/VENDOR												
NAME												
SIGNATURE												
DATE												
BIDDER'S/VENDORS COMPANY SEAL												

CUSTOMER :		PROJECT TITLE		SPECIFICATION :								
BIDDER/ VENDOR SYSTEM		QUALITY PLAN NUMBER PED-506-00-Q-007, REV-03		NUMBER :								
SHEET 7 OF 9		ITEM: AC ELECT. MOTORS 55 KW & ABOVE (LV & MV)		SPECIFICATION :								
SL. NO.	COMPONENT/OPERATION	CHARACTERISTIC CHECK	CAT.	TYPE/METHOD OF CHECK	EXTENT OF CHECK	REFERENCE DOCUMENT	ACCEPTANCE NORM	FORMAT OF RECORD	AGENCY	SECTION		REMARKS
										P	W	
1	2	3	4	5	6	7	8	9	10	11		
2.7	COMPLETE STATOR ASSEMBLY	4.DURATION 1.COMPACTNESS & CLEANLINESS	MA	-DO- VISUAL	-DO- 100%	-DO- -DO-	-DO- -DO-	Log Book Log Book	2 2	- -	1 -	
2.8	BRAZING/COMPRESSION JOINT (IF APPLICABLE)	1.COMPLETENESS 2.SOUNDNESS	CR	-DO- MALLETT TEST & UT	-DO- -DO-	-DO- -DO-	-DO- -DO-	Log Book Log Book	2 2	- -	- 1	
2.9	COMPLETE ROTOR ASSEMBLY	3.HV 1.RESIDUAL UNBALANCE 2.SOUNDNESS OF DIE CASTING	MA CR	ELECT. TEST DYN. BALANCE	-DO- -DO-	-DO- MFG SPEC./ ISO 1940	-DO- MFG. DWG.	Log Book Log Book	2 2	- -	1 1	VERIFICATION FOR MV MOTOR ONLY
2.10	ASSEMBLY	1.ALIGNMENT 2.WORKMANSHIP 3.AXIAL PLAY 4.DIMENSIONS 5.CORRECTNESS, COMPLETENESS TERMINATIONS/ MARKING/ COLOUR CODE 6. RTD, BTD & SPACE HEATER MOUNTING.	MA MA MA MA MA	MEAS. VISUAL MEAS. -DO- VISUAL	-DO- -DO- -DO- -DO- 100%	-DO- -DO- MFG SPEC. MFG.DRG/ MFG SPEC. MFG SPEC. RELEVANT IEC STD	-DO- -DO- -DO- MFG. DRG/ RELEVANT IEC STD MFG SPEC. RELEVANT IEC STD	Log Book Log Book Log Book Log Book Log Book	2 2 2 2 2	- - - - -	- - 1 - -	
BHEL												
PARTICULARS												
BIDDER/VENDOR												
NAME												
SIGNATURE												
DATE												
BIDDER'S/VENDORS COMPANY SEAL												

SL. NO.	COMPONENT/OPERATION	QUALITY PLAN		CUSTOMER :			PROJECT TITLE			SPECIFICATION :		
		CHARACTERISTIC CHECK	EXTENT OF CHECK	TYPE/METHOD OF CHECK	REFERENCE DOCUMENT	ACCEPTANCE NORM	FORMAT OF RECORD	QUALITY PLAN NUMBER PED-506-00-Q-007_REV-03	ITEM: AC ELECT. MOTORS 55 KW & ABOVE (LV & MV)	SECTION AGENCY	REMARKS	NUMBER :
1	2	3	4	5	6	7	8	9	10	11	TITLE	
3.0	TESTS	1. TYPE TESTS INCLUDING SPECIAL TESTS AS PER BHEL SPEC. 2. ROUTINE TESTS INCLUDING SPECIAL TEST AS PER BHEL SPEC. 3. VIBRATION & NOISE LEVEL 4. OVERALL DIMENSIONS AND ORIENTATION 5. DEGREE OF PROTECTION 6. MEASUREMENT OF RESISTANCE OF RTD & BTD 7. MEASUREMENT OF RESISTANCE, IR OF SPACE HEATER 8. NAMEPLATE DETAILS 9. EXPLOSION FLAME PROOFNESS (IF SPECIFIED) 10. PAINT SHADE, THICKNESS & FINISH	MA	ELECT. TEST	1/TYPE/SIZE	IEC-60034/ BHEL SPEC./ DATA SHEET	IEC-60034/ BHEL SPEC./ DATA SHEET	TEST REPORT	2	1*	1	* NOTE - 1
			MA	-DO-	100%	-DO-	-DO-	-DO-	2	1 ^{\$}	1	\$ NOTE - 2
			MA	-DO-	100%	IEC-60034-14/ IEC-60034-9	IEC-60034-14/ IEC-60034-9	-DO-	2	1 ^{\$}	1	\$ NOTE - 2
			MA	MEASUREMENT & VISUAL	100%	APPROVED DRG/DATA SHEET	APPROVED DRG/DATA SHEET & RELEVANT IEC STD.	INSPC. REPORT	2	1	-	
			MA	ELECT. & MECH. TEST	1/TYPE/ SIZE	IEC-60034-05	BHEL SPEC. AND DATA SHEET	TC	2	-	1	TC FROM AN INDEPENDENT LABORATORY, REFER NOTE-3
			MA	-DO-	100%	-DO-	-DO-	-DO-	2	1 ^{\$}	1	\$ NOTE - 2
			MA	-DO-	100%	-DO-	-DO-	-DO-	2	1 ^{\$}	1	\$ NOTE - 2
			MA	VISUAL	100%	IEC-60034 & DATA SHEET	IEC-60034 & DATA SHEET	INSPC. REPORT	2	1 ^{\$}	1	\$ NOTE - 2
			MA	EXPLOSION FLAME PROOF TEST	1/TYPE	VDE-0165/0170/0171	VDE-0165/0170/0171	TC	2	-	1	TC FROM AN INDEPENDENT LABORATORY, REFER NOTE-3
			MA	VISUAL & MEASUREMENT BY ELKOMETER	SAMPLE	BHEL SPEC. & DATA SHEET	BHEL SPEC. & DATA SHEET	TC	2	1 ^{\$}	1	SAMPLING PLAN TO BE DECIDED BY INSPECTION AGENCY \$ NOTE - 2
BHEL												
PARTICULARS												
BIDDER/VENDOR												
NAME												
SIGNATURE												
DATE												
BIDDER'S VENDORS COMPANY SEAL												

	QUALITY PLAN		CUSTOMER :			PROJECT TITLE			SPECIFICATION : NUMBER :			
	SHEET 9 OF 9		BIDDER/ VENDOR SYSTEM			QUALITY PLAN NUMBER PED-506-00-Q-007_REV-03			SPECIFICATION : TITLE			
SL. NO.	COMPONENT/OPERATION	CHARACTERISTIC CHECK	SHEET 9 OF 9	TYPE/METHOD OF CHECK	EXTENT OF CHECK	REFERENCE DOCUMENT	ACCEPTANCE NORM	FORMAT OF RECORD	SECTION AGENCY	P	W	V
1	2	3	4	5	6	7	8	9	10	11		
<p>NOTES:</p> <p>1 DEPENDING UPON THE SIZE AND CRITICALLY, WITNESSING BY BHEL SHALL BE DECIDED.</p> <p>2 ROUTINE TESTS ON 100% MOTORS SHALL BE DONE BY THE VENDOR. IN CASE OF INSPECTION BY CUSTOMER/BHEL OR NOMINATED AGENCY, QUANTUM OF CHECK WILL BE ONE MOTOR OF EACH TYPE.</p> <p>3 IN CASE TEST CERTIFICATES FOR THESE TESTS ON SIMILAR TYPE, SIZE AND DESIGN OF MOTOR FROM INDEPENDENT LABORATORY ARE AVAILABLE, THESE TEST MAY NOT BE REPEATED.</p> <p>4 WHEREVER CUSTOMER IS INVOLVED IN INSPECTION, AGENCY (1) SHALL MEAN BHEL AND CUSTOMERS BOTH TOGETHER.</p> <p><u>Legends for Inspection agency</u></p> <p>1. BHEL/CUSTOMER 2. VENDOR (MOTOR MANUFACTURER)/PACKAGE/SYSTEM CONTRACTOR 3. SUB-VENDOR (RAW MATERIAL/COMPONENT'S SUPPLIER)</p> <p>P. PERFORM W. WITNESS V. VERIFY</p>												
BHEL												
PARTICULARS												
NAME												
SIGNATURE												
DATE												
BIDDER/VENDOR												
BIDDER'S/VENDORS COMPANY SEAL												

B0

General Technical Specification

Sg

as / B



000008

000009

B0. General Specification	0-1
B0.1 Subject of Specification	0-2
B0.2 General Plant Description	0-4
B0.2.1 General purpose of the plant	0-4
B0.2.2 General scope of supply	0-4
B0.2.3 Interface points	0-9
B0.2.4 Site conditions	0-9
B0.2.5 Configuration	0-16
B0.2.6 Layout	0-16
B0.2.7 Design requirements	0-17
B0.2.8 Fuel	0-19
B0.2.9 Output, heat rate and availability requirements	0-20
B0.2.9.1 Guarantee definitions	0-20
B0.2.9.2 Plant output	0-20
B0.2.9.3 Net heat rate	0-22
B0.2.9.4 Auxiliary power consumption, losses, own consumption,	0-23
B0.2.9.5 Plant availability	0-23
B0.2.9.6 Maintenance intervals	0-24
B0.2.10 Mode of operation	0-24
B0.2.11 Electrical network connection conditions	0-26
B0.2.11.1 Essential Electrical Requirements of the PPA	0-27
B0.2.11.2 Essential Requirements of Electricity Grid Code of the Bangladesh Energy Regulatory Commission	0-32
B0.2.12 Facility technical limits	0-43
B0.2.12.1 Unit start	0-43
B0.2.12.2 Despatch ramp rates	0-44
B0.2.13 Environmental impact requirements	0-44
B0.2.14 Provenness Criteria for Critical Equipments and Sub-system	0-46
B0.3 Supplies and Services	0-46
B0.3.1 General	0-46
B0.3.2 Scope of engineering services	0-47
B0.3.3 Deputation of Engineers during the Warranty Period	0-48
B0.3.4 Common equipment and services	0-48
B0.3.4.1 General	0-48



B0.3.4.2	Mechanical	0-49
B0.3.4.3	Substation control and monitoring system	0-51
B0.3.4.4	Electrical	0-51
B0.3.4.5	Instrumentation and Control	0-52
B0.3.4.6	Civil	0-53
B0.3.5	Packaging and transportation	0-54
B0.3.6	Erection, commissioning and testing	0-54
B0.3.7	Training	0-54
B0.3.8	Spare parts, tools, appliances, and consumables	0-55
B0.3.8.1	Spare parts	0-55
B0.3.8.2	Tools and appliances	0-55
B0.3.8.3	Consumables	0-57
B0.3.9	Documentation	0-57
B0.3.9.1	Documentation with tender	0-57
B0.3.9.2	Documentation after Award of Contract	0-61
B0.3.9.3	Data and simulation models	0-69
B0.3.9.4	Requirements for documentation	0-73
B0.3.9.5	Approval procedure for drawings and documents	0-74
B0.3.9.6	Quality control procedure	0-77
B0.3.10	Options and Alternatives	0-79
B0.3.10.1	Option 3.1: Absorber made of concrete (Optional Offer)	0-79
B0.3.10.2	Option 3.2: Combined Limestone System for Both Units (Optional Offer)	0-79
B0.3.10.3	Option 4.1: Open coal stock yard (Optional Offer)	0-80
B0.3.10.4	Option 4.2: Screw unloader (Optional Offer)	0-80
B0.3.10.5	Option 4.3: Open limestone yard (Optional Offer)	0-80
B0.4	Interfaces	0-80
B0.4.1	Battery limits of the plant	0-80
B0.4.2	Interfaces to electricity dispatcher	0-83
B0.4.2.1	Interface between the Power Plant and the NLDC	0-84
B0.4.2.2	Signal interface to NLDC for automatic generation control	0-84
B0.4.2.3	Interfaces between the 400/230kV substation and the NLDC	0-84
B0.4.2.4	Interfaces between the 400/230kV substation and the Power Plant	0-85



B0.4.2.5	Interface to power transmission system (PGCB - Power Grid Company of Bangladesh)	0-86
B0.4.3	Metering	0-86
B0.5	Technical Schedules	0-87
B0.6	General Technical Requirements	0-87
B0.6.1	General requirements	0-87
B0.6.2	Standards and codes	0-88
B0.6.3	Plant and equipment identification	0-91
B0.6.4	Marking and labelling	0-93
B0.6.5	Corrosion protection, coating and galvanizing	0-93
B0.6.6	Vibration	0-101
B0.6.7	Standardization of makes	0-103
B0.6.8	Accessibility	0-104
B0.6.9	Signs & colour code	0-104
B0.6.10	Units of measurement	0-107
B0.6.11	Ways, stairs, ladders, balustrades	0-108
B0.6.12	Hazardous areas, fire fighting & prevention systems	0-109
B0.6.13	Maintenance isolation	0-110
B0.6.14	Materials	0-110
B0.6.14.1	General material requirements	0-110
B0.6.14.2	Specific requirements for high temp./high pressure part materials	0-112
B0.6.15	Pre-service cleaning and protection of plant equipment	0-114
B0.6.16	Welding	0-115
B0.6.17	Mechanical equipment	0-118
B0.6.17.1	Pumps	0-118
B0.6.17.2	Piping and accessories	0-120
B0.6.17.3	Valves, steam traps, condensate drainers , safety valves	0-127
B0.6.17.4	Thermal insulation	0-131
B0.6.17.5	Vessels	0-134
B0.6.17.6	Heat exchangers	0-135
B0.6.17.7	Instrument and service air	0-136
B0.6.17.8	Cranes, hoists and lifts	0-136
B0.6.17.9	Cranes	0-136
B0.6.17.10	Hoists	0-138

000011



Handwritten signature or initials.

B0.6.17.11	Lifts	0-140
B0.6.18	Electrical equipment and works	0-141
B0.6.18.1	Standards	0-141
B0.6.18.2	Voltage levels	0-141
B0.6.18.3	Insulation levels	0-142
B0.6.18.4	Installation conditions and protection class for electrical operational equipment and control and monitoring equipment	0-143
B0.6.18.5	Protective measures, earthing and lightning protection	0-144
B0.6.18.6	Earthing and lightning protection	0-147
B0.6.18.7	Technical conditions for high voltage motors	0-150
B0.6.18.8	Technical conditions for low voltage motors	0-154
B0.6.18.9	DC motors	0-156
B0.6.18.10	Actuator drives	0-156
B0.6.18.11	Frequency converters	0-156
B0.6.18.12	Cable and cable trays	0-160
B0.6.18.13	EMC measures	0-166
B0.6.18.14	Requirements for local cubicles and local housings for e.g. switchgear, control, measurement and signalling equipment	0-168
B0.6.18.15	Local control points and level control cabinets	0-170
B0.6.18.16	Terminal boxes and terminal cabinets	0-172
B0.6.19	Instrumentation and control equipment	0-172
B0.6.19.1	Main design criteria	0-172
B0.6.19.2	Distributed Digital Control, Monitoring and Information System (DDCMIS)	0-174
B0.6.19.3	Programmable logic controllers	0-174
B0.6.19.4	Control cubicles	0-176
B0.6.19.5	Racks, junction boxes	0-177
B0.6.19.6	Mimic diagrams	0-178
B0.6.19.7	Power supply and fusing	0-178
B0.6.19.8	Transmitters	0-179
B0.6.19.9	Temperature measurements	0-181
B0.6.19.10	Pressure measurements	0-183
B0.6.19.11	Flow measurements	0-184
B0.6.19.12	Level measurements	0-186
B0.6.19.13	Analysers and monitoring systems	0-187



B0.6.19.14	Electrical value measurements	0-193
B0.6.19.15	Control valves	0-193
B0.6.19.16	Actuators	0-195
B0.6.19.17	Solenoid valves	0-197
B0.6.19.18	Cabling and wiring	0-197
B0.6.19.19	Instrument and measuring impulse piping	0-199
B0.7	Inspection and Testing	0-199
B0.7.1	General	0-199
B0.7.2	Testing during manufacturing	0-201
B0.7.2.1	Material tests	0-201
B0.7.2.2	Manufacturing tests	0-205
B0.7.2.3	Mechanical equipment	0-212
B0.7.2.4	Electrical equipment	0-214
B0.7.2.5	Control and monitoring equipment	0-234
B0.7.3	Testing at site	0-236
B0.7.3.1	Civil works testing	0-236
B0.7.3.2	Erection tests	0-238
B0.7.3.3	Pre-commissioning tests	0-243
B0.7.3.4	Tests on Completion (Commissioning tests)	0-245
B0.7.4	Performance Tests	0-248
B0.7.5	Reliability test run	0-252
B0.8	Abbreviations	0-253
B0.9	Technical Schedules	0-258



B0. General Specification

Preamble

The Technical Specification is amended in accordance with following Technical Clarifications to Bidding Documents (“Clarification Batches”), which are already published on the BIFPCL’s Website:

- Clarification No. 1 (Clarification #01);
- Clarification No. 3 (Clarification #03);
- Clarification No. 5 (Clarification #05);
- Clarification No. 7 (Clarification #07); and
- Clarification No. 8 (Clarification #08).

Only technical clarifications with regard to content and consequently causing alterations of Scope of Services and Supplies, Technical Requirements, Data Sheets and/or Annexes are incorporated.

General clarifications such as “Subject to BIFPCL’s approval during Basic/Detailed Engineering” or “Details to be discussed during Engineering” are not incorporated as it is self-evident that Contractor’s design and engineering shall subject to Employer’s approval.

Already published Amendments (reference is made to Amendments No. 1 and No. 2) are not again incorporated/included in the amended Technical Specification. This applies for instance for:

- B3, B4 including Data Sheets (replacement of the original documents, refer to Amendment No. 1);
- B12.8 PV Plant and B12.9 Waste Management including Data Sheets (additional documents, refer to Amendment No. 2);
- Annex C, G-05 Health and Safety Manual (additional document, refer to Amendment No. 2); and
- Annex C, M-03 Design Limestone List (replacement of the original document, refer to Amendment No. 1).

In addition some parts of the Technical Specification are modified without reference to a published Clarification or Amendment. This applies for instance for:

- Annexes M-06, M-07, M-08 and M-10, which are revised according to Amendment of B3 and B4 and which shall replace the respective original Annexes.
- Annexes M-04 and M-12, which are revised according to the latest available river water sampling and analysis.

[Handwritten signature]



[Handwritten signature]

[Handwritten signature]

[Handwritten signature]

B0.1 Subject of Specification

The Joint Venture of Bangladesh-India Friendship Power Corporation (pvt) Ltd (BIFPCL) intends to construct a 2x 660 MW_{e, gross} coal fired power plant (the Plant, the Maitree-STPP Project or the Project) in the district of Khulna for which BIFPCL firms as Employer, utilizing high availability, high efficiency steam cycle technology.

The Contractor shall cover all works for the engineering, procurement, construction and commissioning of the whole plant on a turnkey basis.

Two power units with steam generator, steam turbine generator and ancillary systems shall be proposed in a technology that enables the Contractor to guarantee a high net efficiency while achieving a high reliability (certain restrictions regarding the technology and the design parameters apply, as detailed herein). A second phase of the same capacity is foreseen as a future possibility, however, this Specification deals only with 2 x 660 MW_{e, gross} unless otherwise and expressly stated.

The Plant shall be built on a "green field" basis. It shall be conceptualized in accordance with the above criteria, the thermodynamic cycle adopted must be capable of working successfully over prolonged periods and the system shall be able to withstand severe shocks when connected to the Grid as specified in this Section B0. The steam cycle shall operate with once-through technology at supercritical.

The Plant shall be based on supercritical technology. The main steam (MS) pressure at turbine inlet shall be in the range of 250 to 270 bar(g). The MS temperature at turbine inlet shall be in the range of 568 to 600 °C. The reheat steam (RH) temperature at turbine inlet shall be chosen by the Bidder/Contractor accordingly. That means, a proposed plant with a MS pressure at turbine inlet between 250 and 270 bar(g) and MS/RH temperature at turbine inlet upto 600°C/600° will be acceptable.

The Plant shall be suitable to be operated with the specified fuel. Only proven equipment and materials shall be used.

With the Tender the Bidder shall provide evidence:

- that the proposed Plant is based on proven supercritical technology, with similar MS pressure, MS, RH temperature, design and materials; However, Reference plant of MS pressure and temperature at turbine inlet in the range of 242 to 270 bar(g) and 565 to 600 °C respectively, shall also be considered to qualify.
- that the proposed design of the steam generator and auxiliary equipment has been fully proven by extensive successful commercial operation (the experience base for main component and the design data shall be demonstrated by the Bidder);



8140A01/FICHT-15702705-v5
BIFPCL/EPC-Main Plan/2015/1/

FICHTER

B0-2

- that the proposed Plant is based on a reference plant(s) which shall be based on supercritical technology, which shall be of similar design and which shall use similar fuel as specified (The Bidder shall submit with the Tender detailed information on this reference plant(s) and shall allow the Employer and/or his representatives to contact and visit and examine the reference plant(s) in detail).

Regarding the Qualifying Requirements reference is made also to Section I IFB.

Transmission lines (OHL connections) from power plant to HV substation as well as transmission lines (GIL) within HV substation area are included in Bidder's/Contractor's scope of services and supplies. However, transmission lines for PGCB grid connection are out of Bidder's/Contractor's scope of services and supplies. For detailed scope at interface points refer to section B10.3.3 and B10.3.5.

The engineering design of the Plant shall be conceptualized in accordance with the above criteria, and therefore it is vital that the thermodynamic cycle adopted must be capable of working successfully over prolonged periods and the system shall be able to withstand severe load adjustments when connected to the Grid. The proposed Plant shall be based on a reference plant of equal size firing similar fuel, which shall have a proven track record. The Tenderer shall submit with the tender detailed information on this reference plant(s) and shall allow the Employer and / or his representatives to contact and visit and examine the reference plant(s) in detail.

The steam boilers shall be designed to burn coal from Australia, Indonesia, South Africa, Mozambique and potentially other countries and to burn high speed diesel for start-up and shut-down purposes. The Plant is designed for the coal range as per design coal list attached in the **Annexes in Part C**. The steam turbo-generators and thermal cycles shall be selected such, that the Plant heat rate would be optimized under consideration of the investment costs. The condenser cooling systems shall be realized with induced draft wet cooling towers. The turbine generators and all grid relevant parameters shall be designed in accordance with applicable Grid Code and the requirements of NLDC.



The Plant shall be equipped with suitable emission abatement technologies, consisting of primary measures for the CO- and NO_x-reduction, an electrostatic precipitator and a wet flue gas desulphurization plant operating with limestone.

The Project shall include the facilities for the export of the produced power consisting of switchyards, substations and transmission lines.

In addition the Plant shall include all auxiliary and ancillary systems required within the terminal points to render the Plant fit for purpose, this



shall also include workshops, admin and staff amenities buildings and the likes unless expressly excluded in this specification.

B0.2 General Plant Description

B0.2.1 General purpose of the plant

The Plant is intended to serve the increasing power demands of the electricity market in Bangladesh. It will be operated in base load operation but frequency support operation must also be possible.

The scope under the EPC turnkey contract shall cover all services and supplies required to meet the purpose of the Power Plant even if not expressly mentioned in the Bidding Documents. This shall include but shall not be limited to: design, engineering, manufacturing, shop testing, procurement, supply, transportation to site (location of use), handling, storage, insurance, taking any permit/approval required, erection, testing at site, commissioning, performance testing, training Employer's personnel and final completion of entire Power Plant inter alia including steam generators and auxiliaries, turbine generators and auxiliaries, all associated BOP packages, all civil, electrical and I&C works for the entire Power Plant as well as for the jetty and associated facilities and the 400kV/230kV substation as described in the Bidding Documents and complete in all respects for successful operation of both units of 660 MW to dispatch power from the Plant to the grid.

The Plant covers the following main systems and components (including all systems not specifically mentioned):

B0.2.2 General scope of supply

The following data are applicable per unit, unless they refer to common systems. For further information see the respective Sections B1 to B12.



- **Boiler systems (refer to Section B1)**
 - steam generator (supercritical once-through)
 - regenerative air preheater
 - coal pulverizers
 - coal bunker system
 - bottom ash extraction system (dry)
 - boiler fans (PA, SA/FD fans)
 - HP steam / feed water piping
 - HP bypass system
 - air system
 - auxiliary boiler .

- **Turbine systems (refer to Section B2)**



- steam turbine generator
 - LP bypass
 - condenser system incl. evacuation
 - Condenser cleaning system
 - LP/HP heaters
 - deaerator/feed water tank
 - condensate pumps
 - feed water pumps
 - water/steam piping system
 - drip collecting and pump system
 - EOT crane and hoists.
- **Flue gas treatment systems** (refer to Section B3)
 - dust filter system (ESP)
 - FGD system (based on wet limestone process)
 - ID fans
 - flue gas ducts.
- **Fuel and Ash handling system** (refer to Section B4)
 - coal handling system, including:
 - coal unloaders (grab type)
 - stackers
 - portal scraper reclaimers
 - coal yard (90 days capacity at BMCR with worst coal)
 - coal yard roof cover (take-out option)
 - coal dust suppression systems
 - coal crushers
 - Coal screens
 - emergency coal supply by front end loader
 - belt conveyors, junctions towers and other systems as required
 - coal blending silos
 - limestone handling system, including:
 - Stacker
 - limestone yard for 90 days
 - limestone transportation system from jetty to stockyard, as required
 - transportation from stockyard to limestone intermediate silo by front end loader
 - HSD handling, including:
 - HSD truck unloading station
 - HSD tanks
 - HSD transfer pumps and pipe distribution system
 - fly ash handling , including:
 - pneumatic fly ash transportation to intermediate fly ash silos
 - intermediate fly ash silos
 - pneumatic fly ash transportation fly ash storage silos at jetty
 - fly ash storage silos at jetty with truck and ship loading
 - bottom ash handling, including:
 - bottom ash transportation to intermediate bottom ash silos
 - intermediate bottom ash silos



- bottom ash storage silos at jetty with truck loading
- gypsum handling, including:
 - Gypsum storage silo at jetty with truck and ship loading
- common residue handling systems
 - transportation of limestone, bottom ash and gypsum from intermediate silos to storage silos at the jetty by pipe conveyor
 - discharge of fly ash and bottom ash via high concentrated slurry/solids disposal (HCSD) to the ash point.
- **Plant Water and Cooling Systems (refer to Section B5)**
 - Plant water intake channel
 - Plant water intake structures
 - Plant water screening plant
 - Plant water supply pumps
 - Plant water pre-treatment and storage
 - Main cooling water system
 - Cooling Water pump station
 - Induced Draft Cell Cooling Towers
 - Main cooling water collection basin
 - Desalination feed water supply system
 - Auxiliary cooling water system
 - Plant water discharge system
 - Cathodic corrosion protection systems.
- **Water Treatment Systems (refer to Section B6)**
 - Plant water pre-treatment storage and supply
 - Electrochlorination plants
 - Desalination plant
 - Potable water treatment plant
 - Demineralization plant
 - Condensate polishing plant
 - FGD Waste Water Treatment Plant (FGDWWTP)
 - Process waste water treatment facilities including oil separators
 - Sewage treatment plant for sanitary wastes
 - Chemical handling and storage facilities
 - Chemical dosing of cooling water and feed water conditioning
 - Monitoring system for the water/steam cycle.

Note:

The Desalination and Demineralization Plant shall be common for all the units.

- **Electrical systems (refer to Section B7)**
 - All electrical components related to turbine / boiler / flue gas treatment system and BOP systems
 - Power transformers incl. GT, SUT, UAT, all MV- and LV-T
 - Switchboards and power distributions (busducts, cabling etc.)
 - Emergency diesel, DC and safe AC Systems



- 400/230kV GIS including auxiliary and ICT.

Electrical works like illumination, communication, etc. outside plant boundary are not included in the scope of works.

- **I&C systems (refer to Section B8)**
 - All I&C components related to turbine / boiler / flue gas treatment system and BOP systems
 - Central DCS and decentralized PLC Logics
 - Power Plant training simulator.
- **Civil works (refer to Section B9)**
 - site surveys and investigations to ensure safe civil design and undisturbed construction
 - site preparation (incl. site filling works) and temporary site installation.

No grading activities outside the plant boundary shall be considered.

- all civil related works for the Power Plant including turbine/boiler/flue gas treatment system/cooling water system/electrical system/balance of plant etc.
- Marine Works including coal jetty, plant water intake and discharge.
- Power Plant related buildings and structures
- ancillary buildings such as admin building, canteen, storage and workshop building
- ash pond
- HVAC
- Biomass generation plant (use organic waste of Township and Power Plant)

It is to be noted that the biomass plant shall not produce power. The biomass plant is understood as waste segregation and treatment plant. (Refer to B12.9 in Amendment No. 2).

- Cranes.

- **Infrastructure (refer to Section B9)**

The following works are included in the infrastructure lot

- all internal roads incl. tie-in with existing roads at bridge and access roads to nearest township

Bridge and highway from bridge to Khulna-Mongla-Highway will be provided by GOB.

The Interface Point is at the roundabout.

Remark:

Access Road

GOB will construct a 6 Km road connecting the Site with Khulna-Mongla Highway. It is to be highlighted that:



- Bidder/Contractor cannot expect that the access road will be available when the site works start.
- Bidder/Contractor cannot expect that the access road will be suitable for the transportation of heavy equipment to Site.
- Site access and transportation of personnel, material and equipment etc. to Site shall be in the sole responsibility of the Contractor.
- Bidder/Contractor shall execute a transportation study to familiarize himself with the local and Site condition and to elaborate how equipment can be transported to Site.

All roads, except town ship roads are in Bidder's/Contractors' scope. Interface is the roundabout, whereas the roundabout itself shall be constructed by the Bidder/Contractor.

- fencing, gate house inside the boundary
- landscaping in all areas where Contractor work will be performed
- Infrastructure related works outside the boundary wall

Electrical works like illumination, communication, etc. outside plant boundary are not envisaged.

- underground services (non-pressurized - rain water discharge, domestic waste water
- rain water retention basin
- oil water separators.
- **Electrical Works 400/230 kV Substation (refer to Section B10)**
 - 400 kV gas insulated switchgear
 - 400 kV AIS equipments and accessories
 - 230 kV gas insulated switchgear
 - 230 kV AIS equipments and accessories
 - 230 kV XLPE Cables
 - 400/230 kV 520 MVA interconnection transformers
 - Substation Control and Monitoring System (SCMS)
 - 11/0.415 kV auxiliary power transformers
 - Telecommunication Equipment
 - AC/DC installations
 - Power and control cables, bus ducts
 - Tariff metering
 - Substation outdoor lighting
 - Earthing system & lightning protection system
 - Power & auxiliary systems for 400 kV and 230 kV area, incl. coordination with overall system
 - Fire detection, alarm and fire fighting system
 - Substation other supply and services.
- **Jetty structure (refer to Section B11)**
 - Retaining wall
 - Revetment and Shore protection.



- **Auxiliary plant systems** (refer to Section B12)
 - Compressed air system
 - Hydrogen system
 - Workshop and store
 - Chemical laboratory
 - Fire fighting system
 - De-dusting system
 - HVAC system

B0.2.3 Interface points

For interface points see below.

B0.2.4 Site conditions

The following information on local conditions is investigated or compiled by the Employer. The Contractor is hereby in no way relieved from his duties of carrying out all investigations required for satisfactory performance of his works. The Contractor shall perform his own Site visits and investigations, prior to Contract award in order to familiarize him with the existing conditions of the Site and the surrounding area.

Location, accessibility and present condition of the Site

The site for the Maitree-STPP Project is geographically located between 22° 37'0" N to 22°34'30" N and 89°32'0" E to 89°34'5" E, approximately 14 km northeast of the Mongla Port and 14 km northwest of the Sundarbans, is infringed by the Passur and Moidara Rivers to the west and south east respectively. The project requires an area of approximately 500 acres.

The topographical survey indicates a natural ground level of +1.15 to + 1.35 meters above sea level. A severe cyclone in 2009 raised the level to 4.47 meters and it was decided to raise the Plant level to +5.00 meters.

Politically, the site is located in Rampal Upazila of the Bagherat District in the Rajnagar Union

Currently, the Site is accessible by boat only.

The nearest inland port is Mongla port at around 14km direct distance

The proposed Khan Jahan Ali Airport is located at a distance of approximately 12 km from the project site.

Soil conditions

First soil investigations of the Plant site and adjacent areas have been carried out. For information only the findings of these initial soil investigations are attached in Part C Annexes.



In general the subsoil conditions can be described as follows:

- top layer filled sand (with unknown silt content) in Plant area
- underlying layers of clay
- underlying fine sand.

The Contractor shall conduct soil improvement measures at site. Beside other aspects, consolidation of filling shall be incorporated in soil improvement concept.

Seismic zone

Attention shall be paid to seismic parameters. Related to soil type as identified to Soil Investigation Report, the effect of local soils on earthquake ground motion shall be determined.

For site class "S1" and "S", as expected for the Project, site specific studies shall be carried out to determine the design acceleration response spectrum. During field study minimum the following tests shall be executed:

- Seismic cross hole test; and
- Seismic refraction test.

Based on these results a site specific Response Spectra shall be established. Peak spectral acceleration shall be determined, but shall be not less than 0.12g, as mentioned in BNBC 2012, Table 2.5.2.

Site climatic conditions

The Plant site is from the climatic point of view under maritime tropical conditions. The assumed meteorological conditions for the Site are as follows:

The project site is located in the country's South Central Zone consisting of three dominant seasons:

- summer season-March to May
- monsoon season-June to October
- winter season-November to February.

During the Monsoon Season occasional cyclonic storms can occur.

The climatic conditions in the area are continuously monitored by the Bangladesh Meteorological Department (BMD) at the Mongla Meteorological Station.

The temperature varies only slightly throughout the year with the highest temperature of 36.9°C and the lowest temperature of 12.2°C recorded in the period from 1989 to 2008. This distribution is depicted in figure below.



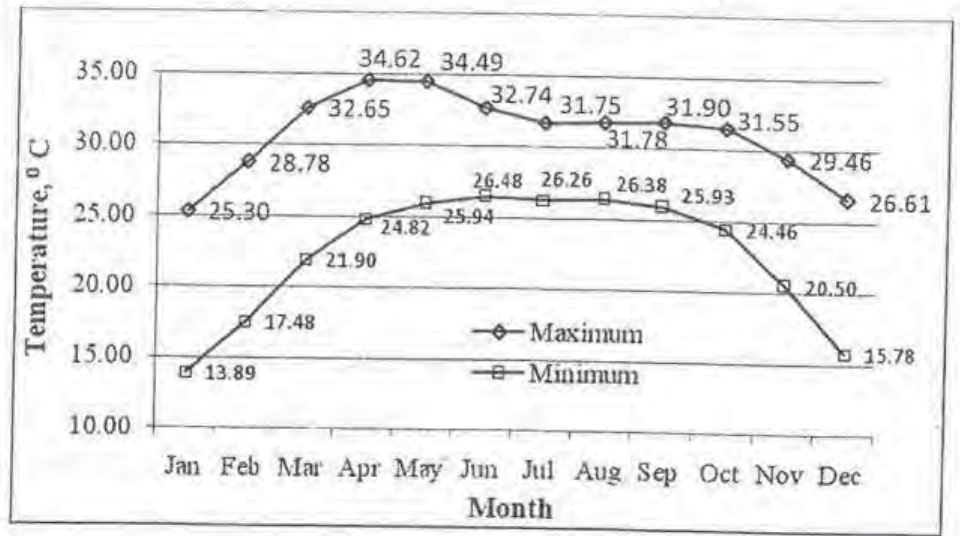

The relative humidity varies drastically during the Monsoon Season with 80% to 90% and the lowest levels of 20% to 30% during the Summer Season. The humidity profile recorded in the same period as the temperature is visualized in below figure.

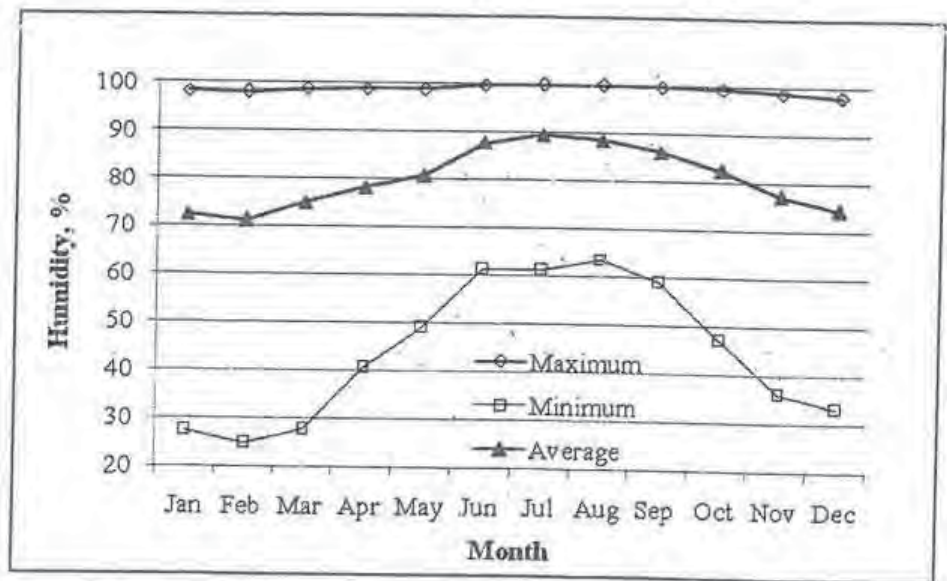

The maximum rainfall occurs during the Monsoon Season by varying between 300 mm and 350 mm with almost no rainfall during the Winter Season.

The average evaporation in the project area varies between 3 - 5 mm/day with its peak of 16 mm/day during July. The average rainfall for the period between 1991 and 2008 is depicted in below figure.



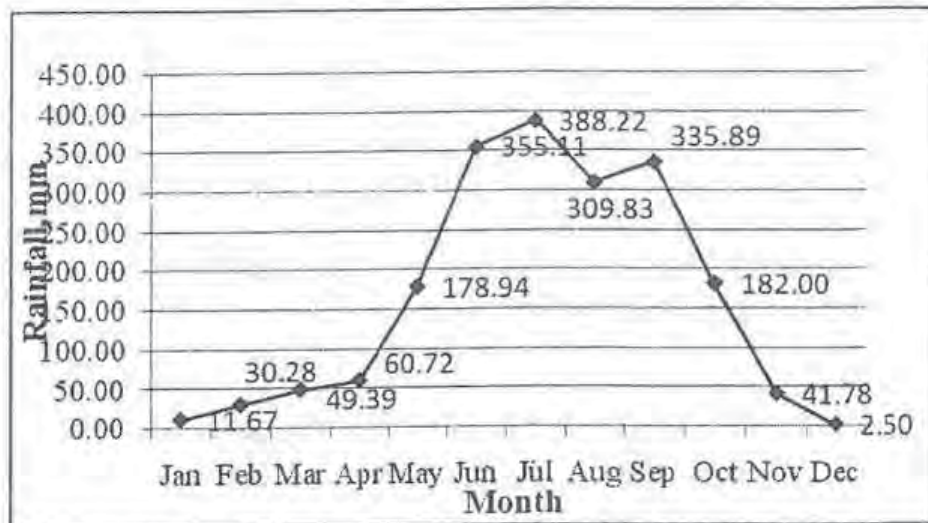

Below definitions are to be used as typical data for the different climatically seasons at the site.

Average Site Condition ASC

Ambient Temperature: 27.3 °C
 Ambient Humidity: 87 %
 Ambient Pressure: 1007.6 mbar
 River Water Temperature: 29.8 °C

Summer Site Condition SSC

Ambient Temperature: 36.9 °C
 Ambient Humidity: 60 %
 Ambient Pressure: 1007.9 mbar
 River Water Temperature: 33 °C

Winter Site Conditions WSC

Ambient Temperature: 12.2 °C
 Ambient Humidity: 100 %
 Ambient Pressure: 1017.2 mbar
 River Water Temperature: 20 °C

Reference Site Conditions RSC

Ambient Temperature: 31 °C
 Ambient Humidity: 88 %
 Ambient Pressure: 1007 mbar
 River Water Temperature: 32 °C



Reference Site Condition shall apply for the Guarantee Values as well as for the Guarantee Tests/Performance Test. However, Plant must cope with the Site Conditions as specified.

Wet bulb temperature shall be calculated by Bidder/Contractor based on ambient temperature (dry bulb), ambient humidity and ambient pressure for the different cases.

Bidder/Contractor shall determine the wet bulb temperature for all site conditions and not only for reference site condition.

Design ambient conditions for Electrical Systems

• Maximum design temperature (outdoor)	45°C
• Maximum daily average ambient shade temperature	38°C
• Maximum monthly average temperature (in the shade)	34.6°C
• Maximum annual average temperature (in the shade)	27.3°C
• Maximum design temperature of the electrical equipment installed indoors in air conditioned rooms	40°C
• Maximum design temperature of the electrical equipment installed indoors non in air conditioned rooms	45°C
• Minimum design temperature	0°C

Marine conditions

Two tides (e.g. flood and ebb) are regularly observed in the Passur River, which enters into the project site through numerous connected creeks.

The tidal range varies between 1.2 and 3.1 meters. The mean water level (CD) is about 0.87 meters (PWD=CD -1.17 meters). The mean high water level varies due to spring-neap tide conditions between +1.60 m and +2.6m PWD. The Highest High Water Level (HHW) is about +3.1m PWD and the Lowest Low Water Level (LLW) is about -1.4m PWD.

The marine conditions are detailed in **Section B11**, with details about:

- water levels
- waves
- currents
- river bathymetry, topography.



The salinity of the Passur River system varies with the amount of fresh water entering the system which is highly seasonal dependent. The surface water temperature ranges between 22.9°C and 33.0°C and the different water quality parameters are tabulated in **Part C Annexes**.

The marine conditions as recorded at Mongla Port Gauge Station (approx. 14 km south-east to the site) are as follows:

• Highest High Water Level	(HHW)	+ 2.642 MSL
• Lowest Low Water Level	(LWL)	- 1.858 MSL



The Power Plant shall be designed for 100 years flood condition based on data provided by relevant Organization in Bangladesh and taking into account the Highest Astronomical Tide (HAT), the maximum wave conditions (including storm surges) and the potential event of Cyclone. The Contractor is responsible to verify the worst conditions.

These reference data are with respect to LAT, which corresponds to the Chart Datum (CD). The site land data is however with respect to the Bangladesh Land Survey Datum (BLSD), which corresponds to approx. +1.55 m CD (hence the MLSD corresponds to MSL).

Design Wave Height 2.0 m
 Design Wave Period 6.0 sec
 Sedimentation and Siltation: Soft to stiff clay and alternations of very sandy and stiff clay.

The results of bathymetric investigations of the Passur River can be found in Part C Annexes.

A water analysis from the area adjacent to the site giving salinity and water quality is shown below:

Sl. No.	Date	Temp	pH	DO	EC	Turbidity	Total Solids	Ca	Mg	Cl	SO ₄	BOD	COD	Salinity
1	7-Jan	27.4	7.74	3010	879	36	68.7	1545	1510	55	5.1	0.8	55	16
2	7-Jan	27.1	7.72	3020	878.1	36	68.5	1570	1510	60	5.1	0.8	55	16
3	7-Jan	27.8	7.71	3030	879	36	68.8	1545	1510	55	5.1	0.8	55	16
1	11-Feb	29.8	7.66	4380	1262	36	182	2590	2180	210	4.7	1	76	23
2	11-Feb	29.2	7.63	4380	1268	36	178	2590	2190	200	4.7	1	76	23
3	11-Feb	29.1	7.65	4380	1263	36	179	2580	2180	200	4.7	1	76	23
1	9-Mar	32.6	7.56	11780	2944.4	38	176	6080	5890	190	4.7	1.2	76	67
2	9-Mar	32.6	7.57	11780	2945.2	38	178	6080	5890	190	4.7	1.2	76	67
3	9-Mar	32.1	7.55	11780	2946.4	38	177	6080	5890	200	4.7	1.2	76	67
1	17-Apr	32.6	7.59	25300	8273	36	185.6	12950	12700	250	4.6	0.7	136	15.5
2	17-Apr	32.6	7.59	25300	8273	36	186.2	12950	12700	250	4.6	0.7	136	15.5
3	17-Apr	32.6	7.59	25300	8273	36	184.8	12950	12700	250	4.6	0.7	136	15.5
1	5-May	32.6	7.59	29300	9480	36	191.6	14900	14800	300	4.5	1.2	177	17.6
2	5-May	32.9	7.54	29300	9470	36	191.6	14900	14800	300	4.4	1.2	177	17.6

Figure 1 Water quality of the Passur River at Mongla point (Source: EIA-Report)



000027

FICHTNER

000028

B0-14

Loc. no.	Date	Temp. (°C)	pH	EC (µS/cm)	Cl ⁻ (mg/l)	T. Alkalinity (mg/l)	Total Hardness (mg/l)	TS (mg/l)	TDS (mg/l)	SS (mg/l)	DO (mg/l)	BOD (mg/l)	COD (mg/l)	Salinity (mg/l)
3	5-May	33.2	7.57	29700	9970	36	199.6	14900	14600	300	4.5	1.2	177	17.6
1	15-Jun	31.6	7.69	18000	5820	36	112.6	9200	9000	200	4.7	1.1	97	10.8
2	15-Jun	31.6	7.69	18000	5800	36	113.2	9200	9000	200	4.7	1.1	97	10.8
3	15-Jun	31.6	7.69	18000	5810	36	112.4	9200	9000	200	4.7	1.1	97	10.8
1	1-Jul	31.6	7.69	440	32.6	36	76.6	285	220	65	5.2	0.8	26	-
2	1-Jul	31.6	7.69	340	32.6	36	76.6	285	220	65	5.2	0.8	26	-
3	1-Jul	31.6	7.69	440	32.6	36	76.6	285	220	65	5.2	0.8	26	-
1	5-Aug	31.6	7.69	275	16.6	36	68.6	197	137	54	5.3	0.7	22	-
2	5-Aug	31.6	7.69	275	16.6	36	68.6	192	137	55	5.3	0.7	22	-
3	5-Aug	31.6	7.69	275	16.6	36	68.6	192	137	55	5.3	0.7	22	-
1	8-Sep	31.8	7.74	270	15.6	36	65.6	180	135	45	5.5	0.7	22	-
2	8-Sep	31.8	7.74	270	15.6	36	65.6	180	135	45	5.5	0.7	22	-
3	8-Sep	31.8	7.74	270	15.6	36	65.6	180	135	45	5.5	0.7	22	-
1	12-Oct	30.6	7.78	290	26.6	36	62.6	192	145	47	5.6	0.7	22	-
2	12-Oct	30.6	7.78	290	26.6	36	62.6	192	145	47	5.6	0.7	22	-
3	12-Oct	30.6	7.78	290	26.6	36	62.6	192	145	47	5.6	0.7	22	-
1	5-Nov	24.6	7.79	340	38.6	36	36.6	210	170	40	5.6	0.7	22	-
2	5-Nov	24.6	7.79	340	38.6	36	36.6	210	170	40	5.6	0.7	22	-
3	5-Nov	24.6	7.79	340	38.6	36	36.6	210	170	40	5.6	0.7	22	-
1	12-Dec	21.5	7.72	320	62.6	36	72.6	320	260	60	5.1	0.9	25	0.4
2	12-Dec	20.9	7.71	320	62.6	36	73.6	320	260	60	5.1	0.9	25	0.4
3	12-Dec	21.1	7.72	350	62.6	36	71.6	320	260	60	5.1	0.9	25	0.4

Figure 2 Water quality of the Passur River at Mongla point (Source: EIA-Report)

Additional information on water quality parameters is shown in Part C Annexes.

Wind data

The project region is characterized by southerly winds from the Bay of Bengal during the Monsoon Season and north-westerly winds from the Himalayas during the Winter Season. During the Summer Season, the wind blows from south-southwest to north-northeast. The annual average wind speed amounts to 1.7 meter/second and the wind rose for the entire year is shown in Figure 5.5.

The wind load calculation for the buildings and structures shall be as per Bangladesh National Building Code -2012, Part 6, Chapter 2.4.

Basic wind Speed, V, shall be taken as 73 m/s, Three-second gust at 10 m above ground in exposure C, having a return period of 50 years.

Unquote



Handwritten signature



000028

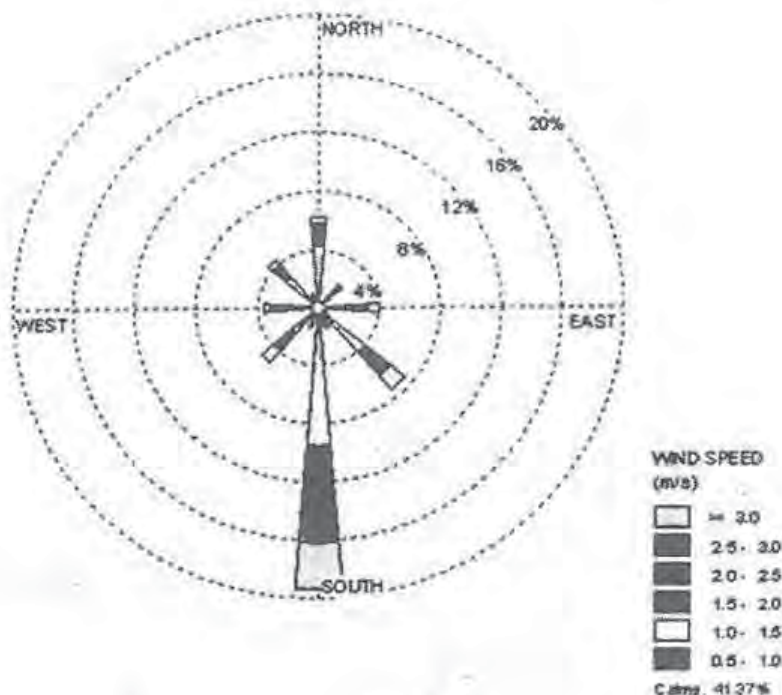

B0.2.5 Configuration

Two (2) Plant units mainly consisting of steam generator, steam turbine generator, flue gas treatment plants and associated equipment represent the core components of the Plant. The configuration of the power units and all of its main components shall be chosen according to proven and reliable vendor configuration. In doing so, adequate safety clearances, fire compartments, favourable layout of the Plant components for monitoring and maintenance and all other requirements such as those during Power Plant construction shall be taken into account.

The cooling requirement of the Plant shall be accomplished by induced draught cooling towers. The coal unloading facilities and the ash and gypsum loading facilities to ships shall be incorporated in a new jetty structure. Other main items are the power island, the coal yard, ash pond and other balance of plant facilities.

B0.2.6 Layout



The existing conditions at the location of the Plant are shown in the site overview as per the indicative layout in **Part C Annexes**. The Tenderer shall perform own Site visits and investigations prior to bidding in order to familiarize himself with the existing conditions. The Contractor shall propose the Plant layout deemed most practical and cost optimized for the Power Plant.



An indicative general layout is shown in **Part C Annexes** where only the major Plant components have been indicated. The indicative layout takes into consideration the location of the river water intake and jetty, however the final layout is subject to hydraulic studies and optimizations by the Contractor. The design shall allow access vessels with a draught of 9.60m at the jetty. The vessels shall be suitable for transport of coal, ash, gypsum and limestone. The dredging works for the construction of the intake and outfall are part of the Contractor's scope.

The intake and outfall locations may change according to the permitting process, results of calculations or model tests or clarifications with the Contractor.

The substations for the export of the produced power are located in the northern portion of the Site. The EHV transmission lines to Dhaka and Khulna are not part of these Tender Documents.

Any costs for relocations or reconfigurations shall exclusively be borne by the Contractor.

The general layout enclosed in Section V TS, Part C is only indicative. Bidder/ Contractor shall elaborate the final layout, which shall be subject to approval by BIFPCL during basic/detailed engineering.

B0.2.7 Design requirements

This specification entails a functional technical specification (FTS). Hence, the Contractor is given as much freedom as possible in designing the main Plant components, characteristics and design data according to the Contractor's experiences and good engineering practice. One main acceptance requirement is that the Contractor's proposed design work shall be based on a very good reference basis. Prototype equipment and/or design features will not be accepted. All parts and equipment shall be arranged in such a manner as to facilitate surveillance by the operator and for ease maintenance, operation and control.

In the event of contradictions or discrepancies within B0 or between requirements in B0 and stipulations other parts of the Technical Specifications these shall be clarified by mutual consent before Contractor signature. In case contradictions have been not clarified the more stringent requirements shall apply.

The main design features (basic design reports, drawings, PFD, P&IDs, design data etc.) and the main vendors and subcontractors shall be subject to the approval by the Employer.

The main equipment/system subcontractors for: steam generator, steam turbine, main transformers, flue gas desulphurization plant shall be firm with the tender. Bidder's/Contractor's sub-suppliers and vendors shall



comply with Provennes Criteria as stipulated elsewhere in the bidding document.

The Employer has the right to refuse design features and vendors or subcontractors, if the Contractor cannot verify the reliability of the suggested design, vendor or subcontractor.

Following transformers shall be considered as "Main transformers":

- generator transformer
- unit auxiliary transformer
- start-up/stand-by transformer
- 400/230 kV interconnection transformers.

The Plant is expected to operate in base-load mode with high plant load factor. The design lifetime of the Plant shall be of not less than 30 years of operation or 200,000 full load operating hours, whichever is longer. The Plant and all its auxiliaries shall be designed to operate for the complete lifetime under the site conditions as described in **Section B0** and dedicated other part of this FTS.

All Plant equipment and material must be suitable for the range of ambient site conditions. In particular the saline atmosphere has to be considered.

The thermodynamic process of the Plant is to be optimized by the Contractor according to the proposed equipment. An economic optimal balance between investment, maintenance and operation expenses and Plant availability (planned and unplanned outages) shall be proposed.

The Contractor shall ensure a design of the Plant to achieve an average target availability of 90 % (regarding the definition and calculation of the availability please refer to Chapter B0.2.9.5). The Contractor shall accordingly provide for all systems:

- sufficient redundancies
- sufficient storage capacity
- appropriate adjustment of control parameters, and
- shall provide an appropriate spare part concept/proposal as further described under Chapter B0.3.7.

A stockyard capacity of 90 days at BMCR operation with design coal is envisaged

The stockpile height shall be approx. 10 m and the angle of repose shall be approx. 37°.

But is to be underlined that it is Bidder's/Contractor's sole responsibility to determine the actual coal yard dimensions (length, width, height angle etc.)



to achieve the envisaged stockyard capacity under consideration of the soil bearing capabilities and the selection of coal yard equipment.

The 90 days storage area is shown in Annex C-01. The extension for further 90 days storage shall be done on the areas which are marked as "construction laydown area" and "site installation".

Redundancy concept

All equipment shall be implemented with (n+1) redundancy - unless otherwise stated -, where n is the number of equipment required to maintain the maximum capacity of a unit. N+1 means that even in case of outage of the biggest component sufficient capacity is available to maintain the maximum capacity of the Power Plant unit.

For all components which are not redundant, the Contractor shall provide a maintenance and spare part concept to ensure that outage times are minimized and to ensure that the required availability is met (refer to Amendment No. 3 and Annexure I to Amendment No. 3, both already published on BIFPCL's Website). Each equipment whose unavailability due to a failure could result in damages to another equipment shall be backed up by a stand-by equipment, one of them being fed by an emergency source in case of external black out.

Failure of any single item of auxiliary equipment including the Power Plant's DCS and electrical systems shall not result in a reduction in power evacuated from the Power Plant.

Replacement and repair of redundant components shall be possible without interrupting Plant operation.

Future Extension

The Contractor shall ensure sufficient space to enlarge the coal storage capacity from 90 day storage to 180 day storage capacity.

All provisions to enable generally the later extension of the coal storage shall be implemented but no additional costs shall be incurred which are not immediately required for the first phase only, unless expressly mentioned here or in the respective parts of this specification.

B0.2.8 Fuel



The Plant shall be operated with imported sub-bituminous and bituminous coal as the principle fuel. Coal will be supplied via bulk carrier vessels (barges and vessels up to 25,000t, to be unloaded at the Coal Jetty.

The Plant will have to be able to be fully operational and in accordance with all guarantee parameters with all coals on a 100 % basis that comply with the coal characteristics as indicated in **Part C**.



For reference purposes, the list that contains the performance coal and the design range for the coals is included in **Part C Annexes**.

For start-up, low-load operation and shut-down, high speed diesel (HSD) shall be used. HSD will be supplied by truck. A typical analysis is given in **Part C Annexes**.

Special technical requirements for the HSD system are given in **Section B4**.

B0.2.9 Output, heat rate and availability requirements

B0.2.9.1 Guarantee definitions

The following guarantees are defined:

Acceptance Guarantees:

The acceptance guarantees must be met in all operating gases unrestrictedly. They are not subject to any correction. Acceptance Guarantees are specified in the Technical Schedules of **Section B0**. The acceptance guarantees are required to be achieved or executed as a condition precedent to Taking Over.

Special Guarantees:

These guarantees are subject to correction, e.g. for fuel characteristics or ambient conditions and if they are not met, they are subject to payment of performance damages. Special Guarantees are specified in the Technical Schedules of **Section B0**.

Minimum Acceptance level (MAL):

Minimum acceptance level (MAL) means the relevant minimum performance levels for the Plant as specified in the relevant part of the Technical Schedules of **Section B0**. The MAL are required to be achieved or executed as a condition precedent to Taking Over.

Liquidated Damages (LD)

Liquidated Damage means the monetary amount to be paid by the Contractor to the Employer if the Special Guarantees are below the Guaranteed Value but above Minimum Acceptance Levels.

B0.2.9.2 Plant output

Gross Electrical Power Output

The gross electrical power output per unit is determined at the turbine generator terminals to the isolated phase busbars, downstream of the connection for the excitation transformer.



8140A01/FICHT-15702705-v5
BIFPCL/EPC-Main Plant/2015/1/

FICHTNER

000034

000033



B0-20

The gross electrical power output per unit shall be: **660.0 MW_{e, gross}** (plus excitation power requirement in case of static excitation) and shall be kept for the whole coal range.

Net Electrical Power Output

The net electrical power output per unit is determined at the off-take point in the switchyard that means at the high voltage (HV) terminals of the dedicated generator transformer (GT).

The net output is determined by subtracting the consumption of the auxiliary transformer including transformer losses from the gross output.

Export Power Output

The export power output of the Plant is determined at the tariff meterings of the Plant.

The export power output of the Plant equals the net power output of both units minus the losses of the interconnection transformers (ICTs) and start-up transformers.

Dependable Capacity

Dependable Capacity means - according to the Power Purchase Agreement (PPA) - at any given time the net amount of capacity at the tariff metering; either for the first generating unit or for the Plant, as the case may be.

MCR - Maximum Continuous Rating

MCR is defined as the maximum continuous rating (gross electrical power output) of one (1) power plant, coal within the coal range, under Reference Site Conditions (RSC), governor valves being throttled to provide frequency variation as required, boiler in normal operating mode including blow down (if applicable), auxiliary steam consumption (if applicable) etc.). All load percentages apply to MCR, unless otherwise noted.

The dedicated net electric power output at MCR with PF and RSC is:

- $P_{MCR-PF-RSC}$ in [MWe]

The dedicated steam generator load at MCR with PF and RSC is:

- $F_{MCR-PF-RSC}$ in [kg/s]

TMCR - Turbine Maximum Continuous Rating / VWO - Valves Wide Open (Peak Load)

TMCR/VWO is defined as the maximum continuous rating, at which the steam turbine is capable of operating under normal operating conditions (see MCR). However, when the governor valves are fully opened TMCR/VWO shall be at least 103% of MCR, i.e.:

- $P_{TMCR} = 1.03 \times P_{MCR}$



That means, Gross Electrical Power Output at

- MCR shall be 660 MW ((plus excitation power requirement in case of static excitation)
- TMCR shall be 679.8 MW.

BMCR - Boiler Maximum Continuous Rating

BMCR is defined as the maximum continuous steam generating capacity, at which the boiler is capable of operating under normal operating conditions (see MCR). BMCR shall be at least 105% of MCR, i.e.:

$$F_{BMCR} = 1.05 \times F_{MCR}$$

The steam flow at superheater outlet at BMCR shall be 105% MCR flow.
Reheater steam flow at BMCR shall be as per Heat Balance Diagram.

MNCR - Minimum Continuous Rating

MNCR is defined as the minimum rating of a power plant unit under normal, continuous operating conditions (see MCR) with coal fire only (without back-up firing with start-up/ignition fuel) with any coal within the coal range. MNCR shall be 30% of MCR.

$$P_{MNCR} = 0.3 \times P_{MCR}$$

B0.2.9.3 Net heat rate

The guaranteed Net Heat Rates of the Units and the Plant are to be given in the Technical Schedules of Section B0.

The competitiveness of the bid will be evaluated by considering the lowest life-cycle-costs of the bids, which will strongly be influenced by the Bid price on the one hand and the guaranteed Net Heat Rate on the other hand. The optimization criterion which may be utilized by the Contractor in the determination of the proposed power station design is the penalty imposed by not achieving the guaranteed Net Heat Rate as per the Contract.

The guaranteed Net Heat Rates refer to the following load points:

- 100% MCR
- 80% MCR
- 60% MCR
- 50% MCR



The „Net Heat Rate“ is the heat rate for the dedicated unit. It is defined according to ASME PTC 46.

Performance Tests/Guarantee Tests at MCR shall correspond to rated pressure (with throttled valves); whereas for part load (i.e 80%, 60%, 50% MCR) the Performance Tests/Guarantee Tests shall be under modified sliding pressure (with 5% throttled turbine inlet valve(s)).

B0.2.9.4 Auxiliary power consumption, losses, own consumption,

Auxiliary Power Consumption

The auxiliary power consumption is the power that is required by the auxiliary power transformer of each unit.

ICT Losses and Start-up Transformer Losses

The losses of the ICTs and start-up transformers apply for the complete switchyard of the Plant.

Own Consumption

The own consumption is the sum of the auxiliary power of both units and the ICT losses and star-up transformer losses.

B0.2.9.5 Plant availability

The Contractor shall:

- a. design and configure all components of the Plant;
- b. propose spare parts stock, comprising as minimum requirement the Initial Spare Parts as requested in Amendment No 3 and Annexure I to Amendment No.3 (both already published on BIFPCL's Website; and
- c. propose maintenance works

in such a way that the average availability of each unit for a period of two year is not lower than 90 %.

The availability for the year means the yearly availability of the Dependable Capacity of each unit for dispatch by the Control Centre, calculated in accordance with the following formula:

$$AF_n = \frac{DC \times \text{hours in the year} - ((MO_{cap} \times MOH) + (FO_{cap} \times FOH) + (SO_{cap} \times SOH))}{DC \times \text{hours in the year}}$$

Where:

- AF_n Availability Factor for the year "n"
- DC Dependable Capacity of the Unit as per the Contract
- MO_{cap} capacity reduction during each maintenance outage in the year "n"
- MOH maintenance outage hours for each maintenance



FO_{cap}	outage (MO_{cap}) in the year "n" capacity reduction during each forced outage in the year "n"
FOH	forced outage hours for each forced outage (FO_{cap}) in the year "n"
SO_{cap}	capacity reduction during each scheduled outages in the year "n"
SOH	scheduled outages hours for each scheduled outage (SO_{cap}) in the year "n"
$\Sigma(MO_{cap} \times MOH)$	maintenance outage energy for the year "n"
$\Sigma(FO_{cap} \times FOH)$	forced outage energy for the year "n"
$\Sigma(SO_{cap} \times SOH)$	scheduled outage energy for the year "n"

B0.2.9.6 Maintenance intervals

The Plant shall be designed to follow at least the following requirements for maintenance intervals:

	Recommended outage duration (days)	Recommended intervals between maintenance outages (years)
Scheduled Maintenance (Minor Overhauls)	to be determined by Contractor, see B0 TS	> two years
Major Overhaul	to be determined by Contractor, see B0 TS	> eight years

It is meant that the Bidder/Contractor shall determine the final maintenance intervals which shall > 2 years for minor overhauls and > 8 years for major overhauls, supposed that the plant is operated with the specified fuels and according to the operation and maintenance manuals.

In case a minor or major overhaul has to be carried out in the first two years after PAC that means during the warranty period it will have an impact on the availability and as the case may be on the availability guarantee.

B0.2.10 Mode of operation

The Plant shall be designed for base load operation and is expected to participate in the system frequency regulation by free governor operation



All the equipment and the facilities shall be suitable for:

- Continuous and short-time operation under average ambient air and river water conditions present on site; and
- Continuous and short-time operation under extreme ambient air and river water conditions present on site.



The design of the Plant shall be based on the following operation and dispatching requirements:

- It shall be capable of following the daily and seasonal demand profile of the electrical network.
- Full compliance with the conditions of the admissible air pollution is required within the power range.
- The power generation shall be fully dispatchable within the technical limits of the Plant to be specified by the Contractor but at least between MNCR and 100 % of the Net Output of the Plant at BMCR.

The units shall be operated as base load plant. It must be capable for following operation modes:

- Fixed/Constant pressure operation upto 40% MCR load;
- Sliding pressure operation from rated pressure down to 40% of rated with as well as without any throttle reserve. At any operating load, the throttle reserve shall be sufficient so as to achieve an instantaneous increase in turbine output by 5% (except MCR, 3% for MCR) of the corresponding load by opening turbine control valve wide open VWO/TMCR). The throttle reserve shall be adjustable to 0% for pure sliding pressure mode operation;
- Fixed/Constant pressure from 100% MCR to 103% MCR (TMCR/VWO) load. Consequently the plant shall be designed also for fixed pressure operation as much higher load than 40% upto to 100% load;
- start-up modes from notice to start to synchronization:
 - hot start: start-up following a continuous shutdown for a period of 8 hours or less in max. 3 hours;
 - warm start: start-up following a continuous shutdown for a period between 8 and 48 hours in max. 4 hours;
 - cold start: start-up following a continuous shutdown for a period more than 48 hours in max. 12 hours;
- shut-down mode;
- Each Unit shall be capable of automatic operation and control and full cyclic operation between MNCR and BMCR without restriction;
- operation without HP heater;

With all HP heaters out of service 100% el. load shall be generated with maximum cooling water temperature, 3% make up and normal auxiliary steam requirement being tapped from cold re-heat line. For bypass of HP heaters a full bypass shall be considered.

- house load operation;
- In case of sudden load throw-off, the steam generator shall be capable of automatically bringing down the steam generating capacity from BMCR to match with HP-LP bypass capacity;



- The Power Plant shall be designed for minimum rate of loading/unloading mentioned below without compromising on design life of pressure parts;
- step load change: Minimum $\pm 10\%$ /min;
- ramp rate: Minimum $\pm 3\%$ /min (MNCR to 50% BMCR);
Minimum $\pm 5\%$ /min (50% MCR to 100% BMCR).

In addition to the the following requirements shall be considered:

- Steam Generator (refer also to Bidding Documents, Section V TS, B1.3.1.1 Operational requirements): "The steam generator shall be operable in the variable (i.e. sliding or modified sliding) and fixed pressure mode";
- Steam Turbine (refer to Bidding Documents, Section V TS, B2.3.15 Control and monitoring equipment): "The steam turbine shall be capable of operating in both the sliding and fixed pressure modes. The Bidder/Contractor shall propose the operating regime which will maintain a highest efficiency of the Plant at various loads."

The Performance Tests/Guarantee Tests shall be executed for the load points as specified. Performance Tests/Guarantee Tests at MCR shall correspond to rated pressure (with throttled valves); whereas for part load (i.e 80%, 60%, 50% MCR) the guarantee test shall be under modified sliding pressure (with 5% throttled turbine inlet valve(s)).

For more detailed requirements refer also to Chapter B0.2.12.

B0.2.11 Electrical network connection conditions

The Plant shall comply with:

- the Essential Electrical Requirement of the PPA
- the latest edition of the Electricity Grid Code of the Bangladesh Energy Regulatory Commission; and
- the Great Britain Grid Code.

In case of contradictions or discrepancies the order of precedence shall be as follows:

- Essential Electrical Requirements of the PPA
 - Electricity Grid Code of the Bangladesh Energy Regulatory Commission
 - Great Britain Grid Code.
- Any other requirements of the Bangladesh Power Development Board (BPDB) or Power Grid Company of Bangladesh (PGCB) shall also be considered.

The Tenderers shall list all those grid connection requirements which cannot be met by the proposed Plant.



B0.2.11.1 Essential Electrical Requirements of the PPA

In this chapter essential electrical requirements for the grid connection and Plant operation are extracted from the PPA. For ease of reference, the relevant chapters/articles of the PPA are indicated.

PPA Section 11: Power Evacuation and Switchyard

11.1 Power Evacuation

The Company shall deliver power at the Delivery Point and BPDB shall evacuate power from the Delivery Point. In this regard, BPDB itself or through PGCB shall construct Power Evacuation Facilities at its own costs and expenses. The Company shall construct switchyard for evacuation of power, with the provision for termination of two 400 kV circuits and two 230 kV circuits of PGCB. This switchyard along with line breaker, CT, PT and other necessary equipment and associated relays, controls, protection, communication and instrument system situated within this switchyard, will be operated and maintained by the Company. The company will also construct connecting lines (U/G or O/H) from power plant to this switchyard. The Company shall provide suitable interface unit at the Company premises for communication links to the power grid SCADA system to accommodate the PGCB and the National Load Dispatch Center (NLDC) requirements. The communication interface unit provided in the Company premises shall be adequate to fulfil the PGCB/NLDC information requirement and may be in the form of RTU or a suitable Gateway on company switchyard automation network at a mutually agreed communication protocol (i.e. IEC-60870-5-101/104). The Company shall be responsible for construction of the interconnections between the switchyard and the Facility. The company Switchyard including the interconnecting link with the generation facility should have design standards as per Minimum Functional Specification. Line relays and controls at the switchyard shall be provided by the Company.

In addition refer to B10.

Only the "start up transformer" and the "future GT's" shall be connected by means of 230 kV cables. Connection between GT's and GIS switchyard shall be done by overhead line.

BPDB shall provide by no later than two hundred and seventy (270) Days prior to Scheduled Initial Operation Date, the following facilities to the Company for the purpose of Commissioning, synchronization and operation of the Facility:

- i. One number 230 KV D/C transmission line from the BPDB / PGCB 230 KV system, to be terminated at the specified point at the switchyard of the Facility;
- ii. (ii) Start-up power of not less than 50 MVA capacity, to be supplied to the Facility through this 230 KV transmission line, by no later



than two hundred and seventy (270) Days prior to Scheduled Initial Operation Date;

- iii. One number 400 KV D/C transmission line from the BPDB / PGCB 400KV system, to be terminated at the specified point at the switchyard of the Facility, with adequate capacity to evacuate entire power generated by the Contracted Capacity of the Facility, by no later than one hundred and eighty (180) Days prior to Scheduled Initial Operation Date;

11.2 Electrical

a. Communication link

The Company shall provide suitable interface unit at the Company premises for communication links to the power grid SCADA system to accommodate the PGCB and the National Load Dispatch Center (NLDC) requirements. The communication interface unit provided in the Company premises shall be adequate to fulfil the PGCB/NLDC information requirement and may be in the form of RTU or a suitable gateway on Company switchyard automation network at a mutually agreed communication protocol (i.e. IEC-60870-5-101/104).

The Company shall be responsible for construction of the interconnections between the switchyard and the Facility. The Company switchyard including the interconnecting link with the generation facility should have design standards as per Minimum Functional Specification. Line relays and controls at the switchyard shall be provided by the Company.

b. Control of Switchyard

Provision and installation of all control and signal cables between the company switchyard and the Facility shall be responsibility of the Company. Necessary interface shall be provided within the switchyard control facility for receiving the signals from PGCB grid control. It shall be responsibility of the Company to lay and terminate cables for this purpose.

All circuit breakers and disconnect switches shall be capable of being electrically controlled from the three control positions as follows:

- i. Local Control: Located adjacent to switching devices, to facilitate maintenance, inspection, and emergency operation.
- ii. Remote Control: Located at the switchyard control room, where switching devices are controlled by direct wire.
- iii. Supervisory Control: Located at the Load Dispatch Centre (NLDC) at Dhaka, for remote control and supervision via the tele-control systems to be supplied by the Company.

Also refer to B10.



The Company shall provide all the necessary control-selector switches, position indicating contacts, and interposing relays.

11.3 Electrical Protection, Communication and Instrument Systems

The Company shall provide a complete and comprehensive protection system for the generators/generator transformers/service transformers, transmission lines and the station electrical distribution systems. The Company shall undertake the installation of the protection relay panels within the control room, wiring between panels and switchyard equipment, and commissioning tests of the protection schemes.

The Company (in consultation with BPDB) shall provide suitable interface unit at the Company premises for communication links to the PGCB's SCADA system for Communication, control, monitoring and voice channels required for PGCB's National/Regional Control Center.

Communication, telemetry, fiber optical terminal, and tele-protection equipment (PLCC) shall be supplied and installed by PGCB at company switchyard end, matching with PGCB's remote substation end requirements. However, line trap and capacitive voltage transformer of required rating along with 48V DC/AC auxiliary supply at company switchyard end shall be provided by company. The wiring of all signalling and control circuits required for the system shall be cabled out to interface marshalling cubicles by the Company. The Company shall supply and install necessary cabling and cubicles. Cabling between the Company's cubicles and PGCB' LDC equipment shall be provided and installed by the Company.

PPA Schedule 1: Minimum Functional Specifications

3. ELECTRICAL REQUIREMENTS

3.1 Generators

- a. Each generator shall comply with IEC 34: Latest Edition and shall be rated to match [each][the] Steam turbine[s] and the steam turbine output over the full range of ambient temperatures. Generator and exciter windings shall possess insulation that is non-hydroscopic and of Class F type in accordance with IEC 85 standard.
- b. Not Used
- c. The quality management of the generator[s] and accessories shall be in accordance with the requirements of ISO 9001, EN 29001 or BS 5750 Part 1 or such other equivalent international quality standards and Prudent Utility Practices.
- d. Temperature detectors shall be provided (to be placed in the hottest zone as decided by manufacturer) to monitor the maximum operating temperature of the machine.
- e. The generator[s] shall be capable of operating within 48.5 Hz and 51.5 Hz and +/- 5% of nominal rated voltage within the power factor



range 0.85 lagging and 0.95 leading at the generator terminal. However, the combined variation in voltage and frequency shall not exceed 5%.

- f. Generator[s] shall have a minimum short circuit ratio complying with IEC 34.

3.2 Excitation System

- a. A continuous fast acting automatic excitation control system of proven design shall be provided to control each generator's voltage without hunting or instability over the entire operating range of the generators.
- b. The excitation system shall be provided with a fast acting MVAR limiter so as to prevent the generator output falling below safe limits. A power system stabiliser shall be incorporated in the excitation system of each generator. BPDB shall provide the settings for the power system stabiliser. The AVR shall be provided with but not limited to Quadrature Droop Compensation and Cross Current Compounding. Protection features, as part of the system shall include overvoltage, overcurrent, voltage transformer (VT) fuse failure, diode failure, overfluxing, and AVR power supply failure. A field shorting or discharge switch feature shall be included in the system as protection against over stressing the generator insulation in the event of a fault.
- c. Manual excitation control facilities shall be provided as back up to the automatic channel, and shall have an adequate range to allow for control of excitation for testing purposes. A true null balance shall be provided to allow for smooth excitation transfer between manual and automatic control.

Bidder's/Contractor's/OEM's standard and proven static excitation system with advanced dual channel digital voltage regulator system which do not require true null meter or follow up device for smooth AVR control transfer between auto and manual will be accepted.

The requirement related to on load tap changer is not applicable to excitation transformer.

3.3 Power and Auxiliary Transformers

The Facility shall include a main transformer for each generator, together with all protection, busbars and disconnectors where required. These main transformers shall be equipped with on load [to be discussed with BPDB] tap changers and shall be of OFAF (forced oil, forced air) or ODAF (oil direct, forced air cooled) or suitable type rated for the full continuous output of the generator.



FICHTNER



BO-30
000043

All service station auxiliary transformers (utilization voltage <650V) shall be OFAF, ODAF or ONAN cooled if located outside, or resin type design if situated inside the buildings.

3.4 Control and Supervision

- a. Supervisory control, monitoring, and data acquisition information shall comply with BPDB's system control concept and proposed/current system. BPDB shall provide all supervisory control, monitoring, and data acquisition circuits from BPDB's National/Regional Control Center, all of which shall conform to the Company's requirements.
- b. Manual synchronising facilities, with such check facilities shall be provided as a minimum for all circuits except for station/service transformer circuits.
- c. The Facility shall be provided with a central on-site control room (CCR) so that operators can control the generators and perform switching and load dispatch duties. A Distributed Control System (DCS) shall be provided to coordinate the control and supervision of the Facility including half hourly Dependable Capacity correction for Reference Site Condition
- d. The Facility shall be equipped with terminals to receive command from the BPDB load dispatch center to allow control from Load Dispatch Center.

3.5 Electrical Protection, Communication Instrument Systems

The Facility shall incorporate a protection system for generators, generator transformers, service transformers, and station electrical distribution systems as per Prudent Utility Practice.

Communication, control, monitoring, and voice channels will be provided between the Facility and BPDB's National/Regional Control Center by BPDB. The Company shall provide interconnection within the Facility for all such communication circuits/channels.

3.6 Power Tariff Metering

- a. The Metering System to be installed at the Facility shall include tariff metering and indicative metering.
- b. For each unit, the measurements, which are used for calculation of the main tariff metered energy, are taken at the outgoing side of the interconnecting lines (main and check) and Back-Up Metering System on the high voltage side of each generator transformer and station transformers, as applicable. The tariff meters installed will measure the net energy sent out from the facility. As provided in Section 12.1, the Back-Up Metering System shall also be of the same type and identical to the Metering System.



Main and check meters shall be provided on HV side of generator and start-up transformer as well as at the outgoing side of the interconnection lines (Reference is made to chapter B10.3.13).

- c. The tariff meters shall have separate facilities for recording the net inflow to the Facility and net outflow of energy from the Facility, and the aggregate of these parameters. This information shall be available for transmission to remote locations via the communication circuit to be provided by BPDB.
- d. Sufficient indicative metering facilities will be installed to allow efficient normal operating and maintenance procedures and automatic control functions to be conducted at the Facility. The metering shall be logged by the Facility's DCS.

PPA Schedule 1: Technical Limits and Contracted Characteristics

1.3 Frequency, Power Factor and Voltage Limits

- a. At rated voltage and frequency, the Facility will operate at 100% load with a power factor in the range 0.85 lagging to 0.95 leading at the generator terminals, which range shall not be exceeded. The curves from the manufacture(s) showing the Reactive Power capability of the generators form part of Schedule 2.
- b. The Facility will operate within the line voltage range used in practice by BPDB and in no case shall the Facility be required to operate more than +5% or less than -10% on the 400 kV high voltage system.
- c. The Facility shall operate within the frequency range 48.5 Hertz to 51.5 Hertz which range shall not be exceeded. The Facility shall be capable of continuous operation for the periods defined in Table 3,



Table 3: As per PPA

Frequency Range (Hz)	Minimum Sustainable Operation
48.5 to 51.5	Continuous
47.5 to 48.5	10 minutes
Less than 47.5	Trip Condition
Greater than 51.5	Trip Condition

B0.2.11.2 Essential Requirements of Electricity Grid Code of the Bangladesh Energy Regulatory Commission

In this chapter essential requirements for the grid connection and Plant operation are extracted from the BGC. For ease of reference, the relevant chapters/articles of the BGC are mentioned in brackets.



The full compliance with the BGC shall be proven by electrical system studies and investigations.

The ratio of X/R can be considered as 40 based on the table 10 given in IEEE C37.010.

It is to be emphasized that there are some discrepancies between the requirements of the BGC and the requirements of the International Electrotechnical Commission Standard IEC 60034. In case of contradictions the requirements and stipulations of IEC 60034 shall prevail.

The Tenderer shall discuss all deviations from the grid connection conditions, which will result in an economic advantage for the investment and the operation of the Plant.

B0.2.11.2.1 System performance (Section 5.4)

Each generating unit shall be capable of generating at full rated power output within following ranges:

	From	To
Frequency	47.5 Hz	52 Hz
Rated Voltage	-10%	+ 10%
Power factor	0.85 lagging *)	0.95 leading

*) This value deviates from the BGC and is chosen as common for generator of this size.

The Transmission System frequency shall normally be 50.0 Hz and shall normally be controlled in the range 49.0 – 51.0 Hz (50 Hz \pm 2%). The User shall however be subject to the grid discipline directed by the Commission.

Voltage variation on the Transmission System shall normally be \pm 10% during emergencies and \pm 5% during normal operation, in accordance with the provisions of Planning and Security Standards for Transmission System. Insulation coordination of the Users' equipment and rupturing capacity of switchgear shall conform to applicable Bangladesh Standards/Codes.

Protection schemes and Metering schemes shall be as detailed in the Protection & Metering Sections of the Code.

For new Power Stations the equipment within their site for data transmission and communications shall be owned and maintained by the respective Generator.

B0.2.11.2.2 Connection point (Section 5.6.1)

Unless specifically agreed with the Licensee the Connection point shall be the outgoing gantry of Power Station switchyard. The metering point shall be at the outgoing connection point. All the substation equipment including Protection, Control and Metering equipment owned by the Generator within



the perimeter of the Generator's site shall be maintained by the Generator. Other Users' equipment shall be maintained by the respective Users. From the outgoing feeder gantry onwards, the Licensee shall maintain all electrical equipment.

B0.2.11.2.3 Data requirements (Section 5.7)

Users shall provide the Licensee with data for this Section as specified in the Data Registration Section.

B0.2.11.2.4 Frequency management & responsibilities (Section 8.3 and 8.4)

Generators shall follow the dispatch instructions issued by the NLDC.

All Generating Units shall have the governor available and in service and must be capable of automatic increase or decrease in output within the normal declared frequency range and within their respective capability limit.

Under certain conditions the system frequency could rise to 52 Hz or fall to 47.5 Hz. All Generating Units should be capable of operating within the range and the NLDC informed promptly of any restrictions. Generators shall be responsible for protecting their Generating Units against damage should frequency excursions outside 52 Hz and 47.5 Hz ever occur. Should such excursions occur, the Generator should decide whether or not to disconnect his apparatus for reasons of safety of apparatus, Plant and/or personnel. The Generator shall inform the NLDC immediately after taking such action.

Sustained rising frequency

Under rising frequency conditions, the NLDC shall take appropriate action to issue instructions to Generators to arrest the rising frequency and restore frequency within normal range. Such instructions may include reducing generated output or de-synchronizing Generating Units from the Transmission System. When the frequency rises above 51.0 Hz actions must be taken immediately by the Generator. Under such condition, the Generating Units which were responsible for seeing frequency of the system shall decrease their Generating Output at a rate of - (minus) 2% per 0.1 Hz for departure of frequency above 51.0 Hz until the frequency is restored within the normal range. The Generator shall inform the NLDC immediately after taking such action.

Sustained falling frequency

Under falling frequency conditions, the NLDC shall take appropriate action to issue instructions to arrest the falling frequency and restore it to be within normal range. Such instructions may include dispatch instructions to Generators to increase output, to synchronize standby Generating Units to



FICHTNER

000048

B0-34

8140A01/FICHT-15702705-v5
BIFPCL/EPC-Main Plant/2015/1

000047

the Transmission System and/or instructions to Distribution Utilities to reduce load demand by appropriate manual and /or automatic load shedding.

When the frequency falls below 49.0 Hz the Generating Units which were responsible for seeing frequency of the system shall increase their Generating Output at a rate of + (plus) 2% per 0.1 Hz (if available) for departure of frequency below 49.0 Hz until the frequency is restored within the normal range. The **Generators** shall be responsible for protecting own units should frequency excursions occurs outside 47.5 to 52 Hz range. The **Generator** shall inform the **NLDC** immediately after taking such action.

All Generating Units that have been declared available shall be required to be synchronized and loaded in the event of the sustained low frequency below 49.0 Hz provided local and safety conditions permit. This action shall be performed without delay after failed attempts to contact the **NLDC**. The **Generator** shall inform the **NLDC** immediately after taking such action.

B0.2.11.2.5 Voltage management (Section 8.5)

The **Licensee** and **NLDC** shall carry out load flow studies from time to time to predict where voltage problems may be encountered and to identify appropriate measures to ensure that voltages remain within the defined limits. On the basis of these studies the **NLDC** shall instruct **Generators** to maintain specified voltage levels at interconnecting points.

The **Licensee** shall continuously monitor 400 kV/ 230 kV/ 132 kV transmission grid voltage levels at strategic substations. The **NLDC** and the **Licensee** shall regulate voltage levels within the prescribed levels.

The **NLDC** and the **Licensee** shall jointly take appropriate measures to control Transmission System voltages that may include but not be limited to transformer tap changing and use of MVAR reserves with Generating units within technical limits agreed to between the **NLDC**, **Licensee** and Generating units.

All Generating Units shall have Automatic Voltage Regulator (AVR) in service.

Generators shall inform the **NLDC** of their reactive reserve capability promptly on request. **Generators** shall make available to the **NLDC** the up-to-date capability curves for all Generating Units, as detailed in **Section 5**, indicating any restrictions, to allow accurate system studies and effective operation of the Transmission System.



B0.2.11.2.6 Monitoring of generation (Section 8.7)

For effective operation of the Transmission System, it is important that a **Generator's** declared availability is realistic and that any departures are continually fed back to the **Generator** to help effect improvement. The monitoring by the **NLDC** of Generating Unit output, and active and reactive reserve capacity, shall be carried out to evaluate the reliability and performance of plant.

The **NLDC** shall continuously monitor Generating Unit outputs and bus voltages (by SCADA). More stringent monitoring may be performed at any time, as detailed in the Testing Section, when there is reason to believe that a **Generator's** declared availability may not match the actual availability or declared output does not match the actual output.

Generators shall provide to the **NLDC** hourly generation summation outputs where no automatically transmitted metering or SCADA equipment exists.

The Generator shall provide other logged readings that the **NLDC** may reasonably require, for monitoring purposes where SCADA data is not available.

Generators shall submit data to **NLDC** as listed in Data Registration Section, termed as Frequency and Voltage Management.

B0.2.11.2.7 Contingency planning (Section 9)

Total System Blackout (Section 9.3.1)

NLDC shall instruct all relevant Generators having Power Stations with Black Start capability to commence their pre-planned Black Start procedure.

Remark: The Maitree-STPP shall **not** have Black Start capability.

Partial Transmission System Blackout (Section 9.3.2)

NLDC shall ensure with the **Licensee** and **Users** that security of the healthy part of the Transmission System is maintained.

NLDC and the **Licensee** shall gradually extend the healthy system to provide start-up power to appropriate Generating Units.

NLDC and the **Licensee** with close coordination with Distribution Utilities and **Generators** shall gradually restore demand to match generation as it becomes available.

All **Users** shall take care to ensure load generation balance is maintained all times under **NLDC's** direction.

FIGHTNER



Special Consideration (Section 9.5)

During the restoration process following Transmission System blackout conditions, normal standards of voltage and frequency shall not apply.

B0.2.11.2.8 Protection (Section 12)**General Principals (Section 12.3)**

No item of electrical equipment shall be allowed to remain connected to the Transmission System unless it is covered by appropriate protection aimed at reliability, selectivity, speed and sensitivity. Guidelines mentioned in protection manuals may be kept in view.

All Users shall co-operate with the Licensee to ensure correct and appropriate settings of protection to achieve effective, discriminatory removal of faulty equipment within the time for target clearance specified in this Section.

Protection settings shall not be altered, or protection bypassed and/or disconnected without consultation and agreement of all affected Users. In the case where protection is bypassed and/or disconnected, by agreement, then the cause must be rectified and the protection restored to normal condition as quickly as possible. If agreement has not been reached the electrical equipment will be removed from service forthwith.

Fault Clearance Times (Section 12.5)

From a stability consideration the maximum fault clearance times for faults on any User's system directly connected to the Transmission System, or any faults on the Transmission System itself, are as follows:

Target Clearance Times:

- i. 400 kV : 100 ms
- ii. 230 kV : 160 ms
- iii. 132 kV : 160 ms.



Slower fault clearance times for faults on a Users system may be agreed to but only if, in the Licensee's opinion, system conditions allow this.

Generator Requirements (Section 12.6)

All Generating Units and all associated electrical equipment of the Generator connected to the Transmission System shall be protected by adequate and coordinated protection so that the Transmission System does not suffer due to any disturbance originating from the Generating Unit.

In the event of failure of the protection systems provided to meet the fault requirements detailed above, backup protection shall be provided by the Generator with a fault clearance time not slower than 400ms for faults on the Generating Unit's HV connections. The protection shall also cover EHV lines and transformers to the standards as for the Transmission System and



circuit breaker fail, pole slipping, loss of excitation, power system stabilizer and negative phase sequence tripping.

Transmission Line Requirements (Section 12.7/12.7.1/12.7.3)

Every 400 kV Line and 230 kV Line taking off from a Power Station or a substation shall have main protection and backup protection as mentioned below. The Licensee shall notify Users of any changes in its policy on protection from time to time.

- Two distance protections plus directional earth-fault protection (in directional comparison scheme) shall be provided as the Main-1 and Main-2 protection respectively.
- One stand alone directional 3-phase or 2-phase over-current relay and one directional earth-fault relay shall provide the backup protection.
- Three pole and/or single pole single shot auto-reclosing equipment shall be fitted, as appropriate, as considered by the licensee. All auto-reclosing equipment will be made inoperative for three phase trip-out and/or back-up protection operation.
- Both distance and directional earth-fault functions shall have compatible communication aided transfer trip scheme.

For short transmission lines Line Differential Protection along with backup Directional normal, Directional time-lag and/or Non-Directional Over-current and Earth-fault protection shall be provided as an appropriate protection scheme.

Relay Panels for the protection of lines of the Licensee taking off from a Power Station shall be owned and maintained by the Licensee. Generators shall provide space, connection facility and access to the Licensee for such purpose.

The Generator shall ensure that all common facilities needed for installing required protective relaying are made available to the Licensee.

Transformer Requirements - Generating Station/Transmission System (Section 12.9.1)

All windings of auto-transformers and power transformers of EHV class shall be protected by differential relays and REF relays as main protection.

In addition there shall be one backup time lag 3-phase Over-current and Earth-fault protection relay. For parallel operation such backup protection shall have directional feature. For protection against heavy short circuits, the Over-current and Earth-fault relays should incorporate a high set instantaneous element. In addition to electrical protection, gas operated relays, winding temperature protection and oil temperature protection shall be provided. Over-voltage, thermal overload and over-fluxing protection should also be provided.



8140A01/FICHT-15702705-v5
BIFPCL/EPC-Main Plan/2015/1/

FICHTNER



~~000052~~

BQ-38

000051

Substation Busbar and Fire Protection (Section 12.10.1/12.10.2)

All Users shall provide adequate main and backup bus zone protection incorporated with Local Breaker Backup (LBB) or Breaker Fail Protection (BFP) for busbars in all 400 kV, 230 kV and 132 kV class substations.

Adequate precautions shall be taken and protection shall be provided against fire hazards to all Apparatus of the Users conforming to relevant Bangladesh Standard Specification and/or provisions in the Electricity Rules, 1937 and amendments thereof and other standard engineering practices.

Data Requirements (Section 12.11)

Users shall provide the Licensee with data for this Section as specified in the Data Registration Section.

B0.2.11.2.9 Testing (Section 14)**Introduction (Section 14.1)**

This Section specifies the responsibilities and procedures for arranging and carrying out Tests which have (or may have) an effect on the Transmission System or the Generator's or Distributor's systems.

Objective (Section 14.2)

The objective of the Section are to establish whether Generating Units can operate within their Generation Schedule and Dispatch parameters as registered under the Data Registration Section and that the Generator and Distributor comply with the Connection Section. It shall also establish whether each Generating Unit's declared availability capacity is as declared and that the requirements of the provisions of frequency, voltage management and reserve capability are met in accordance with the provisions of the Grid Code.

B0.2.11.2.10 Performance standards for transmission (Section 17)**Purpose and Scope (Section 17.1.1/17.1.2)***Purpose:*

- a) To ensure the quality of electric power in the Grid.
- b) To ensure that the Grid will be operated in a safe and efficient manner and with a high degree of reliability; and
- c) To specify safety standards for the protection of personnel in the work environment

Scope of Application:

This Chapter applies to all Grid Users including:

- a) the Licensee
- b) the System Operator/ NLDC
- c) generators



- d) distribution utilities, and
- e) any other entity (e.g. owners of HVDC converter, large furnaces, etc.) with a User System connected to the Grid.

Power Quality Standards (Section 17.2)

Power Quality Problems (Section 17.2.1)

For the purpose of this Article, Power Quality shall be defined as the quality of the voltage, including its frequency and the resulting current that are measured in the Grid during normal conditions.

A Power Quality problem exists when at least one of the following conditions is present and significantly affects the normal operation of the System:

- a) The System Frequency has deviated from the nominal value of 50 Hz.
- b) Voltage magnitudes are outside their allowable range of variation.
- c) Harmonic Frequencies are present in the System
- d) There is imbalance in the magnitude of the phase voltages.
- e) The phase displacement between the voltages is not equal to 120 degrees.
- f) Voltage Fluctuations cause Flicker that is outside the allowable Flicker Severity limits, or
- g) High-frequency Over-voltages are present in the Grid.

Frequency Variations (Section 17.2.2)

The nominal fundamental frequency shall be 50 Hz. The control of System frequency shall be the responsibility of the System Operator. The System Operator shall maintain the fundamental frequency within the limits of 49.0 Hz and 51.0 Hz during normal conditions.

Voltage Variations Section 17.2.3)

For the purpose of this Section, Voltage Variation shall be defined as the deviation of the root-mean-square (RMS) value of the voltage from its nominal value, expressed in percent. Voltage Variation will either be of short duration or long duration.

A Short Duration Voltage Variation shall be defined as a variation of the RMS value of the voltage from nominal voltage for a time greater than one-half cycle of the power frequency but not exceeding one minute. A Short Duration Voltage Variation is a Voltage Swell if the RMS value of the voltage increases to between 110 percent and 180 percent of the nominal value. A Short Duration Voltage Variation is a Voltage Sag (or Voltage Dip) if the RMS value of the voltage decreases to between 10 percent and 90 percent of the nominal value.

A Long Duration Voltage Variation shall be defined as a variation of the RMS value of the voltage from nominal voltage for a time greater than one minute. A Long Duration Voltage Variation is an Under-voltage if the RMS value of the voltage is less than or equal to 90 percent of the nominal voltage. A Long Duration Voltage Variation is an Overvoltage if the RMS

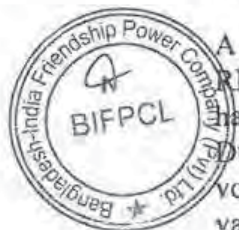

value of the voltage is greater than or equal to 110 percent of the nominal value.

The Grid Owner and the System Operator shall ensure that the Long Duration Voltage Variations result in RMS values of the voltages that are greater than 95 percent but less than 105 percent of the nominal voltage at any Connection Point during normal conditions.

Harmonics (Section 17.2.4)

For the purpose of this Section, Harmonics shall be defined as sinusoidal voltages and currents having frequencies that are integral multiples of the fundamental frequency. The Total Harmonic Distortion (THD) shall be defined as the ratio of the RMS value of the harmonic content to the RMS value of the fundamental quantity, expressed in percent.

The Total Demand Distortion (TDD) shall be defined as the ratio of the RMS value of the harmonic content to the RMS value of the rated or maximum fundamental quantity, expressed in percent. The Total Harmonic Distortion of the voltage and the Total Demand Distortion of the current at any Connection Point shall not exceed the limits given in Tables 17-1 and 17-2, respectively.

Harmonic Voltage Distortion

Voltage Level	THD*	Individual	
		Odd	Even
400 kV	1.5%	1.0%	0.5%
132-230 kV	2.5%	1.5%	1.0%
66 kV	3.0%	2.0%	2.0%

* Total Harmonic Distortion

Table 17-1: Maximum Harmonic Distortion Factor

Harmonic Current Distortion

Voltage Level	TDD*	Individual	
		Odd	Even
400 kV	1.5%	1.0%	0.5%
132-230 kV	2.5%	2.0%	0.5%
66 kV	5.0%	4.0%	1.0%

* Total Demand Distortion

Table 17-2: Maximum Harmonic Distortion



T.H.D of the line-to-line terminal voltage for the Generator shall be as per latest IEC 60034-3 (clause 9.11.2 - Limits (Total Harmonic Distortion (THD) for synchronous machines) will be accepted. As per this clause of IEC, it shall be limited to 5%. However, at the 400 kV and 230 kV grid connection points the requirements of the specification Section B0.2.11.2.10 shall apply.



000054

000055

Voltage Unbalance (Section 17.2.5)

For the purpose of this Section, the Negative Sequence Unbalance Factor shall be defined as the ratio of the magnitude of the negative sequence component of the voltages to the magnitude of the positive sequence component of the voltages, expressed in percent. For the purpose of this section, the Zero Sequence Unbalance Factor shall be defined as the ratio of the magnitude of the zero sequence components of the voltages to the magnitude of the positive sequence component of the voltages, expressed in percent. The maximum Negative Sequence Unbalance Factor at the Connection Point of any User shall not exceed one (1) percent during normal operating conditions.

The maximum Zero Sequence Unbalance Factor at the Connection Point of any User shall not exceed one (1) percent during normal operating conditions.

Voltage Fluctuation and Flicker Severity (Section 17.2.6)

For the purpose of this Section, Voltage Fluctuations shall be defined as systematic variations of the voltage envelope or random amplitude changes where the RMS value of the voltage is between 90 percent and 110 percent of the nominal voltage. For the purpose of this Section, Flicker shall be defined as the impression of unsteadiness of visual sensation induced by a light stimulus whose luminance or spectral distribution fluctuates with time.

In the assessment of the disturbance caused by a Flicker source with a short duty cycle, the Short Term Flicker Severity shall be computed over a 10-minute period. In the assessment of the disturbance caused by a Flicker source with a long and variable duty cycle, the Long Term Flicker Severity shall be derived from the Short Term Flicker Severity levels.

The Voltage Fluctuation at any Connection Point with a fluctuating demand shall not exceed one percent (1%) of the nominal voltage for every step change, which may occur repetitively. Any large Voltage Fluctuation other than a step change may be allowed up to a level of three percent (3%) provided that this does not constitute a risk to the Grid or to the System of any User. The Flicker Severity at any Connection Point in the Grid shall not exceed the values given in Table 17-3.

	Short Term	Long Term
132 kV and above	0.8 unit	0.6 unit
below 132 kV	1.0 unit	0.8 unit

Table 17-3: Maximum Flicker Severity



Transient Voltage Variations (Section 17.2.7)

For the purpose of this Section, Transient Voltages shall be defined as the high-frequency Over-voltages that are generally shorter in duration compared to the Short Duration Voltage Variations. Infrequent short-duration peaks may be permitted to exceed the levels specified in Section 17.2.4 for harmonic distortions provided that such increases do not

compromise service to other End-users or cause damage to any Grid equipment. Infrequent short-duration peaks with a maximum value of two (2) percent may be permitted for Voltage Unbalance, subject to the terms of the Connection Agreement or Amended Connection Agreement.

B0.2.11.2.11 House load operation (not requested by the Grid Code of Bangladesh)

Each Unit shall successfully go to house load operation in the event of disconnection or complete isolation of such Unit from the Grid. Each Unit shall be capable of performing house load operation up to a maximum of 2 hours. A Unit that has achieved house load operation shall not be shut down without the prior consent of the NLDC.

1. Within such time, each Unit on house load operation shall be ready to be resynchronized to the Grid System and able to increase output in the usual manner.
2. In the event the Grid System is not energized, each Unit on house load operation shall have the capability to energize a dead bus and to start the other Unit, when instructed by the NLDC. Subsequently, upon instruction by the NLDC, such Unit shall be able to increase output in the usual manner.

B0.2.12 Facility technical limits

The following sections describe the minimum requirements regarding the facility.



B0.2.12.1 Unit start

The facility shall be able to achieve the following operating levels within the same period (in minutes) specified in the following table.

Conditions	Boiler firing to turbine start	Steam turbine start to synchronous	Notice to start to steam turbine synchronous	Synchronous to full load	Total
Cold start after more than 48 hrs outage	TBD	TBD	12 hours	TBD	TBD
Warm start after 8 to 48 hrs shutdown	TBD	TBD	4 hours	TBD	TBD
Hot start after 8 hrs shutdown	TBD	TBD	3 hours	TBD	TBD

Table B0-3: Required start-up times (minutes)¹

¹ To be determined by the Tenderer



B0.2.12.2 Despatch ramp rates

Ramp rates of 3%/min to 5%/min are expected for the Power Plant when operating between 30% and 100% BMCR. Ramp rates of less than 5%/min are subject to Employer's approval.

The facility shall be able to achieve the following despatch ramp rates as specified in the following table:

Despatch ramp rates		(Excluding Pulverizer changing over time)	
		Loading (MW)	Ramp rates (MW/min)
Cold start	(0 to 7%)	0 – 42	TBD
	(7 to 30%)	42 – 180	TBD
	(30 to 50%)	180 – 300	TBD
	(50 to 75%)	300 – 450	TBD
	(75 to 100%)	450 – 660	TBD
Warm start	(0 to 7%)	0 – 42	TBD
	(7 to 30%)	42 – 180	TBD
	(30 to 50%)	180 – 300	TBD
	(50 to 75%)	300 – 450	TBD
	(75 to 100%)	450 – 660	TBD
Hot start	(0 to 7%)	0 – 42	TBD
	(7 to 30%)	42 – 180	TBD
	(30 to 50%)	180 – 300	TBD
	(50 to 75%)	300 – 450	TBD
	(75 to 100%)	450 – 660	TBD

Despatch ramp rates (per Unit)²



B0.2.13 Environmental impact requirements

Air pollution

The permissible exhaust gas emissions shall comply with the stipulations of the generating license granted. Compliance for the following pollutants shall be guaranteed and proved:

Emission	Unit	Maximum Threshold
Total PM	mg/Nm ³	50
Sulphur dioxide (SO ₂)	mg/Nm ³	200
Nitrogen oxide (NO _x)	mg/Nm ³	510

Table B0-5: Emission limits

Note:

- NO_x refers to oxides of nitrogen, referenced to NO₂
- Reference conditions for NO_x, SO₂, and particulates are 6 % O₂, dry (i.e. zero moisture), 0 °C and 1013 mbar atmospheric pressure, that means, unit for emissions is mg/Nm³

² To be determined by the Tenderer

The stack height shall follow the requirements of the Environment Conservation Rules, 1997 of Bangladesh.

Water pollution

Permissible emission limits for aqueous discharges into the river via the Plant Water Discharge System shall comply with the Waste Water Effluent Standards, see Technical Schedule of **Section B0** and IFC EHSG - TPP - Table 5 - Effluent Guidelines. If there are differences in effluent limits in the two guidelines the more stringent limit should be applied. But limit of TDS with 2100 ppm shall not be followed.

The findings of the Environmental Impact Assessment (EIA) shall be used for Plant design.

Other waste water which is not allowed to be discharged to the requirements waste water treatment plant will have to be disposed externally.

Soil contamination

The Plant should be designed, operated and maintained in such a way to prevent any soil contamination by oil and chemical spillage during subsequent operation and maintenance of the Plant.

Permissible noise levels

The Plant shall be designed and constructed inter alia in accordance with IFC Environmental, Health and Safety Guideline Thermal Power Plants (EHSG-TPP) to reduce the operating noise level as much as possible. No individual within the boundary of the Site shall be exposed to a noise level exceeding the limits stated in the EHSG-TPP and "The Sound Pollution (Control) Rules, 2006".

Far field noise under normal operation of the Plant measured along the Site boundary of the Plant towards the Township shall not exceed 50 dB(A) during daytime and 40 dB(A) during night-time.

For any other point of the Site boundary of the Plant the noise pressure level shall not exceed 60 dB(A) during daytime and 50 dB(A) during night-time. Day time is defined from 6:00 am to 9:00 pm. Night time is defined from 9:00 pm to 6:00 am.

During the engineering phase the Contractor shall award an independent Third Party to conduct noise propagation calculation to prove that the permissible noise levels at the Plant boundary are met.

In addition the statutory requirements of Bangladesh shall be followed as far as stricter as the other standards, such as EHSG-TPP.

Furthermore the following maximum noise pressure levels shall be not exceeded:

dB(A)

- At 1 m horizontal distance from equipment/enclosures and 1.5 m above operating floor 85
- Within turbine building 90 (Note 1 & 2)
- Steam generator 90 (Note 1)
- Within central control rooms in power plants 55.

Notes:

1. At normal operation
2. Generally at maximum 88 dB(A), exceptions are the turbine stop valve and control valves 95 dB(A) and turbine drive boiler feed pumps 97 dB(A).
3. Noise level from non continuous operating valves (like pressure control valve, water separator drain control valve, etc.) shall be limited to 90 dB(A).
4. The noise level for safety valves including ERV shall be limited to 115dBA for the safety valves provided with silencer as per OSHA standard. Noise level around Mill will be 90 dBA.
5. Noise level at the boundary fence as specified must be complied with.

High noise areas (areas with noise levels >85 dB(A)), which require that personal noise protecting gear shall be used when working in such high noise areas, shall be marked.

Electromagnetic Field (EMF)

In accordance with the EHS-G-TPP the occupational EMF exposure shall be prevented or minimized.

All technical measures and the required equipment necessary to fulfil the EHS-G-TPP shall be provided by the Contractor. Inter alia areas with expected elevated EMF levels shall be identified and marked.

Fire and explosion, electrical and chemical hazards

In accordance with the EHS-G-TPP all technical measures to prevent, minimize and control physical, electrical and chemical hazards shall be included in the Contractor's scope of services and supplies.

- B0.2.14** Provenness Criteria for Critical Equipments and Sub-systems shall be as per Annexure-I of B0 (Refer Amendment no.05 to Bidding Documents).

B0.3 Supplies and Services**B0.3.1 General**

The scope of this specification covers all supplies and services required for meeting the purpose of the Plant, even if these are not expressly mentioned in the following.



The works include the following main components, where the detailed scope of supply is given in the corresponding Sections as listed below:

- **Section B1:** Steam generator plants
- **Section B2:** Steam turbine generator plants
- **Section B3:** Air and flue gas systems
- **Section B4:** Fuel and Ash handling system
- **Section B5:** Plant Water and Cooling Systems
- **Section B6:** Water treatment systems
- **Section B7:** Electrical works
- **Section B8:** Instrumentation and control works
- **Section B9:** Civil Works
- **Section B10:** Electrical Works 400/230 kV Substation
- **Section B11:** Jetty
- **Section B12:** Auxiliary plant systems

The corresponding Annexes and Attachments are contained in **Part C**.

The relevant costs of these supplies and services to be given in the price schedules are to be assigned corresponding to the individual items concerned for each of the sections. The costs of the common equipment and services have to be included in the corresponding Section prices.

B0.3.2 Scope of engineering services

The Engineering services refer to the complete specified Plant and covers following services:

- **Basic and detail engineering**

- **Permit engineering**

The Contractor shall actively participate in drawing-up of all required licensing applications.

All services shall be performed by the Contractor to affect the required permits to commence the works and operate the Plant, including but not limited to:

- preparation of all documents as required according to the pertinent laws
- clarifications with authorities
- participation in all clarification meetings
- construction permits
- boiler and pressure vessel approvals
- water/waste water permits
- operation permits
- fire fighting approvals
- and all other services as required.



Furthermore, all other required engineering and other services to meet the purpose of the Project and the agreed project time schedule shall be executed by the Contractor.

B0.3.3 Deputation of Engineers during the Warranty Period

At least seven (7) English speaking graduate engineers, (3 operation experts, 1 Turbine & auxiliary expert, 1 Boiler & auxiliary expert, 1 for I&C, 1 for Generator and Switchyard area expert), with adequate knowledge and at least fifteen years of relevant experience of pulverised coal fired power plant of 500 MW and above unit size including two years of relevant experience in power plant of same type and technology being offered here from the Contractor, shall be permanently at site during the Warranty Period that means two months prior to PAC of first unit of the Plant upto end of warranty period of second unit. They shall be competent to advise and lead the Employer's staff on all aspects of engineering, operation and maintenance.

B0.3.4 Common equipment and services

The following supplies and services are to be included in the corresponding Section prices:

B0.3.4.1 General

- Material and personnel costs for tests and inspections which are mandated in legislation

Employer/employer representative/TPA will be responsible for their respective expenses in connection with inspection, examination and testing.

- Material and personnel costs for site inspections
- Declaration of conformity with requirements from Bangladesh and markings for all machines
- Engineering design of complete supplied equipment including interface coordination
- All as-built documents (on data carriers; data formats as requested by the Employer)
- Quality control plan and safety plan
- Complete documentation as set out in the tender specification
- Operating manual (5 hardcopies and 3 electronic copies)
- Detailed operating and maintenance instructions/manual (5 hardcopies and 3 electronic copies)
- A maintenance program for all equipment of the Plant instructions (5 hardcopies and 3 electronic copies)



- For all documents softcopy format shall be searchable pdf, however in addition all drawings, diagrams like P&IDs shall be supplied in ACAD or other editable format, and all lists in Excel format.
- All insurances, such as, but not limited to:
 - transport insurance, incl. marine cargo insurance
 - installation all risks,
 - third party liability,
 - automobile liability,
 - M.V. Policy for: motor vehicles, private cars & commercial vehicles,
 - CPM policy for heavy construction equipment,
 - Workmen's Compensation,
 - Employer's liability,
 - Group personal insurance, for contractor's & subcontractor's employees.

B0.3.4.2 Mechanical

- All necessary pipelines, valves, actuators
- All required line warm-up systems
- All connection and adaptation works for tie-in into general supply systems
- All necessary vents, drains and rinsing connections as well as tundishes with covers, as far as possible aggregated to common groups of on operating level
- All connection elements, screws, bolts, nuts, including gaskets and seals as necessary
- All temporary installations required for tie-in measures including post-weld heat treatment complete etc.
- All temporary pipework as required during connection measures
- Check of required existing structures, plant components and systems and their rehabilitation where they lie within the scope of supply, or definition of required measures in good time if they lie outside of the scope of supply
- All necessary support structures, hangers etc.
- All necessary base frames, mounting plates, grouted in parts, rag bolts, covers etc.
- All required steel parts embedded in concrete
- All couplings and coupling guards for electric motors and other drives
- All necessary lifting equipment and hoists (hooks and provisions for chain blocks to be provided for repair work where loads exceed 50 kg, hoists to be provided for repair work where loads exceed 200 kg, and electrical operated hoist for loads exceeding 2,500 kg)
- Required safety equipment, pressure relief valves etc.
- All thermal and noise insulation including cladding as well as any other noise attenuation measures
- Stairways, ladders, platforms, galleries and walkways to all plant components, including escape routes as necessary

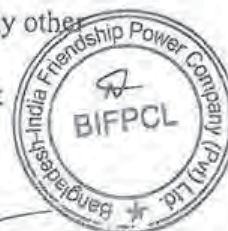

B140A01/FICHT-15702705-v5
BIFPCL/EPC-Main Plant/2015/1/

FICHTNER

B0-49

~~000063~~

000062

- All necessary steel structures, stairs, ladders on platforms weather protection
- All required ventilation or air conditioning equipment for safe operation of mechanical and electrical equipment, to be supplied
- All necessary corrosion protection measures for plant components and equipment stored or mounted on site up to the time of reliability test run
- Complete primer and top coatings conforming to colour code, clarified with the Employer
- Necessary noise abatements measures
- All required freeze protection and electric trace heating for outdoor installations
- Complete labelling of all plant components according to the Employers system and in plain language
- All fire protection measures
- All necessary lubrication systems
- Initial lubricant filling and sufficient lubricants for commissioning and reliability test run, minimization of lubricant types by screening and coordination with the Employer
- Water and demineralised water for pre-commissioning and commissioning activities,
- Provision of all connections and temporary pipework for acid cleaning, steam purging of the live steam line and flushing / cleaning of systems as necessary
- Flushing of all other lines including disposal of the effluents; protection with wood and/or plastic at all instrumentation and appendages to be installed during construction
- All standard accessories and auxiliary equipment which normally form part of the scope of supplies
- All necessary tests, inspections and works acceptances as well as all certificates and reports of these
- Exchange of filter elements following reliability test run
- Removal of temporary strainers
- Valve trims for purging and subsequent exchange
- Removal of any unused material
- Scaffolding for all work above ground level
- Necessary connection points for on line condition-based monitoring equipment.



B0.3.4.3 Substation control and monitoring system

At least but not limited to:

- all field equipment such as bay control units, bay protection equipments (described under chapter "Substation Control and Monitoring System) to be installed at the substation. The field equipment for the substation shall be interconnected by separate IEC 61850 fiber optic station busses in ring configurations. (The use of an IEC 61850 optical fiber link is required for all connections of equipments which directly interact with the station bus (the switches). In the particular case where, for example, the IEDs are wired to the BCU and only the latter is connected to the station bus, electrical links (preferably IEC 61850) are allowed for wiring connection of the IEDs with the BCU but an IEC 61850 optical fiber link between BCU and switches is required.
- all equipment to control and monitor the auxiliary equipment of the substation connected to the SCMS by redundant fiber optic links
- common bay unit / station computers
- operator and engineering workstations with TFT monitors and printers to be installed at the substation control room
- all equipment necessary for the implementation of an OPC server/client architecture between the substation and the Power Plant control rooms in order to allow the supervision and monitoring of the substation from the Power Plant DCS facilities. The OPC-server configuration shall be redundant
- Maintenance / service laptop which shall also be used for protection and disturbance analysis by respective log-in.
- data communication gateway to the National Load Dispatch Center (NLDC),
- energy meters for active energy (kWh) with accuracy of 0.2 S and for reactive energy (kVarh) with an accuracy of 0.5 S for tariff metering shall be provided for each outgoing line.

B0.3.4.4 Electrical



- All necessary electrical drives
- Complete installation material, that is wiring, cabling and piping material, all needed fastenings, conduits, brackets and other supports
- All required junction boxes and cubicles
- All field control boxes
- All cubicles, junction boxes, marshalling racks, terminal boxes, etc.
- Complete labelling of electrical equipment (also inside of cabinets)
- Lightning protection
- Electrical earthing of the equipment
- Cable and cable trays
- All necessary cables and wires for power, AC and DC instrument transformers, control, measuring, signals, etc.



- All necessary number plates for identifying the cables (numbering code to be determined)
- All necessary fixing materials
- All necessary fire protection materials for making good the cable openings through walls and ceilings as well as between switchgear and control, measuring, recording and switchgear cubicles, operating panels and desks, etc.,
- All necessary plastic protecting tubes for the cable runs
- All necessary materials for laying the cables in the ground
- All necessary cable connections including compression cable lugs, fixing and clamping materials, etc.
- All necessary cable sealing ends and cable connecting sleeves including fixing materials
- All necessary compression connectors.

B0.3.4.5 Instrumentation and Control

- All necessary control systems and auxiliaries
- All measurements and field control loops (thermometers, pressure gauges, transmitters, sensors, analyzers, local regulating devices, etc.) as well as all instruments for reliability test and checks for the duration of the performance tests
- Other special instruments/ systems like acoustic steam leak detection system (ASLD), acoustic pyrometer, communication systems, ambient air quality monitoring system (AAQMS), effluent quality monitoring system (EQMS)
- Complete installation material, that is wiring, cabling and piping material, all needed fastenings, conduits, brackets and other supports
- All required junction boxes and cubicles
- All field control boxes
- All instruments mounted on instrumentation racks
- All cubicles, junction boxes, marshalling racks, terminal boxes, etc.
- Signal exchange between local control system and DCS as well with instruments/control systems of other lots
- Complete labelling of I&C-equipment (also inside of control cabinets)
- Lightning protection
- Electrical earthing of the equipment
- Clarification of all logic interconnections: sequence, interlocking, protection, safeguarding for coordinated operation/start-up/shut down of individual items of equipment
- Cable and cable trays
- All necessary cables and wires for power, AC and DC instruments, transformers, control, measuring, signals, etc.
- All necessary number plates for identifying the cables (numbering code to be determined)
- All necessary fixing materials



- All necessary fire protection materials for making good the cable openings through walls and ceilings as well as between switchgear and control, measuring, recording and switchgear cubicles, operating panels and desks, etc.
- All necessary plastic protecting tubes for the cable runs
- All necessary materials for laying the cables in the ground
- All necessary cable connections including compression cable lugs, fixing and clamping materials, etc.
- All necessary cable sealing ends and cable connecting sleeves including fixing materials.

B0.3.4.6 Civil

- All necessary surveying works including all soil investigations required for safe and reliable design and construction
- Preparation of site, demolition works, removal of underground obstacles
- Earthworks, drainage, excavation and refilling works
- Piling of structures to prevent subsidence
- Concrete and reinforced concrete works, masonry and earthing
- Concreting of maintenance platforms and lay-down areas
- Water proofing works for pressing and non-pressing water
- Fire protection during construction
- Roofing; non asbestos
- Plumbing
- Facade works/glazing works; non asbestos
- Non-load bearing walls/installation partitions/dry construction works
- Metalwork and blacksmith work/raised flooring/doors and gates/sheet metal work
- Flooring work
- Fire protection with plumbing; fire protector
- Painting/varnishing
- Craneway works
- Room air conditioning systems, where required, e.g. control cubicle rooms, etc.
- Potable water, service water and waste water
- Housekeeping during construction
- Staff facilities during construction
- Transport of all dumping material to dump locations
- Performance and interpretation of soil bearing tests
- Temporary fencing of construction site
- Site offices for Employer and Employer's representatives
- The Contractor's site office
- Landscaping of areas required under this contract.



B0.3.5 Packaging and transportation

- Suitable packaging and transportation of the entire scope of supplies,
- free construction site, on-site transportation and temporary storage including inspections and, if necessary, ensuring the prerequisites for transportation
- Disposal of packing and transportation material
- Customs clearance
- Crane or hoisting facilities at seaport and site
- Transportation to site
- Unloading at site.

B0.3.6 Erection, commissioning and testing

- Complete erection of the scope of supply up to operational readiness: This includes mobilization and provision of the required supervisory staff, skilled and unskilled personnel, as well as of installation scaffolding, cranes, hoists, equipment and materials, personnel accommodation, prescribed tests and inspections.
- Commissioning and optimization of all plant components as well as conducting all necessary measurements.
- Supervision of erection, commissioning and Reliability Test Run of complete supplied equipment.
- All testing as specified.

B0.3.7 Training

The Contractor shall provide comprehensive training for Employer's engineering, operating and maintenance staff (Employer's staff) covering all aspects of the Power Plant equipment and systems and operation and maintenance.

The Contractor shall train, instruct and supervise the Employer's staff to an adequate standard of knowledge and capability for good trouble shooting, repair and of the plant equipment as well as to an adequate standard for safe and efficient commercial operation of the Plant.

The training shall at least include:

- training at manufacturer's works during the assembly of the major plant items
- classroom and hands on training
- on the job training during erection, commissioning and reliability test run; and
- simulator training.

The Contractor shall submit the training plan for the classroom, on the job and simulator training including schedule, place, content of lectures etc. for



the Employer's approval no less than six (6) months in advance to the cold commissioning.

Post training assessment shall be carried out and documented. In case the results of the training are below the expectations, which have been agreed upon by both Contractor and Employer before training, the respective training modules shall be repeated in an improved way and the related cost for the repeated training shall be borne by the Contractor. In case the results are below expectations (to be agreed upon by both Contractor and Employer before training) the respective training modules shall be repeated in an improved way.

B0.3.8 Spare parts, tools, appliances, and consumables

B0.3.8.1 Spare parts

Reference is made to Amendment No 3 and Annexure I to Amendment No.3 (both already published on BIFPCL's Website).

B0.3.8.2 Tools and appliances

The following tools and appliances shall be supplied under this Contract for use by the Employer:

- a. two (2) sets of all special tools and gauges required for the operation and maintenance of the Plant
- b. one (1) set of special lifting and handling appliances required for the operation and maintenance of the Plant
- c. suitable storage bins/racks/shelves for the above.
- d. Standard tools according to the relevant Technical Schedules.

For I&C e.g. following special tools and gauges shall be provided (including but not limited): pressure calibrator, portable pressure source, calibration pressure pump, deadweight testers, precision pressure gauges, manometers, temperature baths/calibrator, multimeters, RTD simulator/tester, thermocouple calibrator precision source and simulation equipment, direct temperature indicating meter, standard pH-tester, multi function process calibrator, loop calibrator, voltage/current/temperature reference generator, intrinsic safe multifunction calibrator, depth gauge, feeler gauge, dial indicators, portable handheld tacho meters, double channel digital storage oscilloscope, conductivity meter, electronic stethoscope, general purpose vibration meters, hand-held IR thermometers, humidity & moisture meters, hazardous and toxic leak detectors, field meters (leak and emission detectors), laser distance meters, US distance estimators, US handheld flow meters, US handheld level meters, portable sound level meter, anemometer, barometer, stop watch, standard technician tools etc.

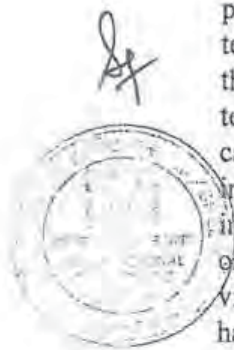

One set of tool shall be handed over in new condition and one set shall be used by the Contractor for erection/commissioning.

Each tool or appliance is to be clearly marked with its size and/or purpose.

The tools and appliances supplied may have been used for erection and commissioning purposes by the Contractor, but shall be handed over in good working order.

Each set of tools and appliances under category (a) and (d) shall be suitably arranged in fitted boxes of mild steel construction, the number of boxes being determined in relation to the layout of the Plant and equipment in question. If the weight of any box and its contents should be such that it cannot conveniently be carried, it shall be supported on steerable rubber-tyred wheels.

Each cabinet and box shall be painted, fitted with a lock and clearly marked in white letters with the name of the item of equipment for which the tools and appliances contained are intended.

Suitable storage racks shall be provided for all portable lifting tackle in this contract.

Suitable lifting lugs, ears or ring bolts, or tapped holes for lifting rings shall be provided on all equipment items where the weight exceeds 15 kg.

All lifting tackle shall be stamped with a unique identification number and safe working load. A test certificate from an approved authority shall be supplied for each item of lifting tackle.

The Contractor shall provide a schedule of all lifting tackle and tools and appliances being supplied, for the approval of the Employer/Engineer.

The Contractor shall provide all runway beams, trolleys, lifting blocks, special slings etc. necessary for the safe and efficient handling and maintenance of the works. Particular attention shall be paid to high level equipment such as deaerators. Electrically operated hoists and runway trolleys shall be provided for all lifts in excess of 2.5 tons.

The tools and appliances with the appropriate storage racks, cabinets and boxes shall be handed over to the Employer at the time of taking over of the unit.

Where the Contract includes site erection, any special tools or appliances required solely for erection shall be provided by the Contractor for his own use and shall remain the property of the Contractor.

One set of tools shall be handed over in new condition and one set shall be used by the Bidder/Contractor for erection/commissioning.

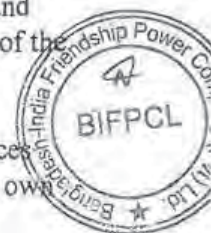

For handling of the generator stator the following alternative is also acceptable: Tandem/combined operation of two turbine hall EOT cranes for which the necessary arrangements shall be provided. In such case the combined capacity of two EOT cranes shall not be less than the 105% of weight of generator stator, including the weight of lifting beam with swiveling equipment and slings. Main Turbine hall building civil and structural design shall be done accordingly.

Special lifting and handling appliances may be used by the Contractor for erection and commissioning, but shall be refurbished by the Contractor and shall be handed over to the Employer as per in new condition.

B0.3.8.3 Consumables

The Contractor shall supply all chemicals, reagents, resins, lubricants, grease, filters and consumable items for operation up to COD including top up requirement at the time of issuance of PAC/ declaration of COD. All lubricants proposed for the Plant operation shall be suitable for all operating and environmental conditions that will be met on site consistent with good maintenance procedures as instructed in the maintenance manuals.

All types of chemicals, consumables, lubricants and grease shall be readily obtainable locally and a number of different types shall be kept to a minimum. For each type and grade of lubricant recommended, the Contractor shall list at least three equivalent lubricants manufactured by alternative companies.

The Contractor shall submit to the Employer the list and schedule of lubricants, greases, chemicals and consumables items including items qualities and quantities required per month of the Plant operation for the Employer's approval eighteen (18) months prior scheduled COD of the 1st Unit.

B0.3.9 Documentation

B0.3.9.1 Documentation with tender

General

- If a consortial bid is submitted, documents on the consortial agreement
- Description of options and alternatives offered
- Completely filled in price-, guarantee-, time-, and data schedules of the specification
- List of proposed makes and vendors
- Reference lists for delivery and installation of plants of similar type and size with separate references for the steam generator and steam turbine operating at same or similar parameters
- Requirements of grid code which cannot be met (if any)



- Description of means to accomplish primary frequency control according to grid code
- Description of means to accomplish secondary frequency control according to grid code
- Time schedule engineering for deliveries, erection/installation, commissioning and reliability test run
- Complete description of the Plant offered including description of the process and the equipment
- Layout drawings of the Plant
- Dimensioned drawings and sectional views of the principal plant components including materials
- Schematics of the principal plant systems
- General descriptions of individual systems and descriptions of operation including description of start-up, shutdown and emergency shutdown procedures
- All other documents necessary for comprehension of the offered plants and equipment
- Documents on the quality assurance system, including Quality Assurance Plan (The Quality Assurance Plan shall meet the requirements of ISO 9001:2000 and cover all activities under this FTS.)
- Training program and schedule for Employer's personnel
- Space requirement for lay down area, construction site and equipment
- List of personnel including qualification to operate the Plant and to perform day-to-day maintenance
- Initial Spare Part List as described under B03.7
- Equipment maintenance schedules for reliable centered maintenance.

Mechanical

- Process flow diagram of all systems
- Performance diagrams of main pumps and fans
- Plant and major equipment start-up curves for cold (all material on ambient temperature), warm and hot start up to MCR
- Water and waste water mass balances.

Steam Generator

Description for the equipment offered, giving information about:

- general outline of installation
- main control loops
- description of boiler protection system
- graphs showing the performance characteristic versus the load (flue gas temperatures, steam temperatures etc., including h-p-diagram)
- correction curves for ambient conditions and fuel variations
- material diagram showing material, dimensions, highest flue gas temperature and highest steam temperature, design material temperature and maximum admissible material temperature and design pressure for components of the steam/water system



- pulverizer performance diagram showing turn-down range of pulverizers and pulverizer outlet temperatures for different coal qualities.

Steam turbine generator

Description for the equipment offered giving information about:

- general outline of installation,
- main control loops,
- conclusive correction curves for steam turbine and cooling system with variations in:
 - power output with ambient temperature, humidity and river water temperature
 - specific heat rate with ambient temperature, humidity and river water temperature
 - generator efficiency vs. power output for varying power factor
 - degradation curves for the power unit and the Plant
 - diagram showing the output of the turbine, of the generator and of the generator transformer versus the ambient air temperature (from +10 °C to +40 °C), humidity (between 20% and 100%) and river water temperature (from +20 °C to +35 °C).

Electrical system



- Electrical single-line diagram for the Power Plant including LV, emergency, safes AC and DC power supply
- Electrical single line diagram for the 400/230 kV GIS
- Unit protection and measuring single line diagram
- Performance diagrams (circle diagrams) of generator, saturation curves, unbalanced load diagrams
- Diagram with the output of the turbine, the generator and the generator step-up transformer versus ambient temperature
- Preliminary lists of motors and electrical consumers including power demand
- Auxiliary power requirement of the plant unit
- Arrangement of generator bus duct up to generator transformer, H.V and L.V. Cubicles, unit auxiliary transformer
- General arrangement of main electrical equipment within the relevant buildings, rooms, etc., including cross-sections
- Arrangement of connection from generator transformers to 400 kV GIS
- Arrangement of connection from start-up/stand-by transformers to 230 kV GIS
- General arrangement of the 400/230 kV GIS substation including the related control building and connection 400/230 kV interconnection transformers to 400 kV and 230 kV GIS
- Architecture drawing of the 400/230 kV substation control and monitoring system
- Description of the individual protection relays with related reference lists
- Description of the main electrical equipment (e.g. generator, excitation, AVR, generator protection, generator step-up and unit auxiliary transformer, start-up/stand-by transformer, 400/230 kV interconnection

transformer, 400 kV reactors, 400/230 kV GIS, Substation Control and monitoring System, 400/230 kV protection systems, 11 kV switchgear, etc.)- with related reference lists.

Instrumentation & control system

- Control system architecture showing all components provided for this Plant in their actual structural arrangement
- Layout drawing central control room
- Description of hardware, software and design philosophy of the DCS
- Reference list for the DCS with indication of plant type, system architecture and size of the system
- Data sheets, descriptions and brochures of the offered BMS and BPS
- Data sheets, descriptions and brochures of the offered local control systems, in particular PLCs
- Data sheets, descriptions and brochures of the CEMS including (if applicable) common emission data evaluation devices
- Data sheets, description and brochures of the communication systems as specified in the relevant Sections of **Section B8**
- CCTV system philosophy description and configuration drawing
- Data sheets, description and brochures of the training simulator as specified in the relevant Section of **Section B8**
- Temporary list of all drives, such as unidirectional motors, MOV's, SOV's and remotely operated control valves
- List of modulating controls
- List of package systems (black boxes)
- Description of field equipment.
- Description of structure of the control functions including list of unit co-ordination level, functional group level, sub-group level
- Description of the interface to the boiler protection system and the steam turbine generator protection system
- Procedure for calculation of the availability of the DCS.

Civil

- Architectural outline drawings for all buildings and building structures showing the arrangement of the complete Plant, inclusive of all levels and Sections
- Site plan of the complete Plant showing all buildings, building elements, roads, landscaping etc.
- Schematic design of main buildings
- Typical concrete block pad and chimney foundation
- Typical pole foundation for HV towers
- Details, with calculations, for the main foundation system proposed
- Basic design of Site infrastructure
- Basic design of the chimney
- Basic detail of the coal storage yard
- Basic detail of the ash pond.



000074

B0-60

000073

B0.3.9.2 Documentation after Award of Contract

The documents required for design, construction, installation, operation and maintenance of the entire Plant shall be submitted by the Contractor in good time so as to permit the Plant as a whole to be erected in compliance with the specified time table.

All documents, including the installation and operation and maintenance manuals as well as the related software shall be in fluent, legible English. In addition, operation and maintenance manuals shall be translated into Bangla and provided as paper copies and in electronic format.

The Contractor shall list all the drawings and submission schedule for the Employer's approval. Only the most important documents are listed below. These documents shall be submitted sufficiently in advance, so that corrections and amendments desired by the Employer as well as resubmission of the documents will not result in any delays with respect to the guaranteed time schedule. The Employer reserves the right to request from the Contractor additional drawings, documents, etc. as may be required for proper understanding and definition of the design and engineering of the Plant.

The overall responsibility with regard to completeness, correctness and suitability for the permit application process remains with the Contractor. In no case any comment, correction, amendment and approval (if any) by the Employer shall relieve the Contractor from this responsibility.

The drawings and documents to be submitted during this stage are listed in the various Sections and comprise the following. They shall be submitted within the specified time scale calculated in weeks after Award of Contract. Details shall be agreed according to the approval procedure for drawings and documents above.

The Contractor may propose modifications to the list as given below, in order to ensure timely completion of permit application documents and performance of the works according to the project's requirements and in accordance with the specified project time schedule. Any modification to this list shall be submitted for Employer's review and approval.

The Employer reserves the right to require detailed information on the progress of drawing and document preparation from the Contractor at any time during this stage.

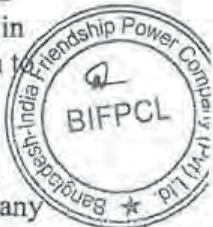

Document	Purpose	Weeks after Contract Award	
		Preliminary	Final
• General			
• Current list of drawings		4	every 1 month
• Complete list of documents		4	every 1 month

Document	Purpose	Weeks after Contract Award	
		Preliminary	Final
with proposed submission deadlines			
• Progress reports	I	-	every 1 month
• Erection and installation progress reports	I	-	every 1 month after start of site activities
• Quality assurance procedure and program	A	with Bid	24
• structure of Contractors QA&QC manpower at site	A	with Bid	24
• indicative field quality plan for civil works	A	with Bid	24
• Plant layout	-	with Bid	16
• List of subcontractors/manufacturers	A	with Bid	12
• Proposed inspection and testing programs	A	12	24
• Noise propagation calculations	A	-	24
• Detailed program for commissioning	A	24	6 months ahead start pre-commissioning
• Studies / surveys regarding water intake and water discharge	A	12	24
• Detailed program of Reliability Test Run	A	24	6 months ahead start Reliability Test Run
• Detailed program of Performance Tests	A	24	6 months ahead start Reliability Test Run
• Testing documents/Report of results of all tests	A	2 weeks after test	6 months ahead start Reliability Test Run
• Training program	A	-	6 months ahead of pre-commissioning
• As-built-documentation including drawings of all equipment	A	-	1 month after COD of the 1 st Unit
• Declaration of conformance with all local regulations	I	-	latest with start of pre-commissioning
• Spare part lists	A	with Bid	18 months ahead of COD of 1 st Unit
• Time scheduling	A	with Bid	every 1 month
• Overall time schedule for design, manufacture, supply, assembly, erection and commissioning broken down for the principal plant components and all	A	with Bid	every 1 month



000076000075 B0-62

Document	Purpose	Weeks after Contract Award	
		Preliminary	Final
construction works, stating dates for completion of any preparatory work from others which may be necessary			
Detailed erection, installation and commissioning schedule	A	12	2 months ahead of erection / pre-commissioning
Mechanical Engineering			
Arrangement drawings of principal components with ducts and platform layout	A	with Bid	12
Arrangement drawings of auxiliary equipment (cubicles, etc.)	A	12	24
Process flow diagrams	A	with Bid	12
Piping and Instrumentation schematics and isometric drawings, including list of pipelines and valves, stating materials, nominal diameters and pressure, dimensions, insulation thickness of all pipes	A	8	24
Plans of main pipelines including location of cable routes	A	8	24
Characteristics of pumps, fans etc.	I	16	24
Details of required auxiliary energy sources and consumables (e.g. electricity, steam, chemicals, instrumentation, air, working air) with condition data, required qualities and consumption values	I	16	24
Water and waste water balances	A	with Bid	36
Thermodynamic diagrams / heat balance diagrams	I	with Bid	24
Start-up and shutdown diagrams with descriptions (cold, warm, hot)	A	with Bid	2 months before pre-commissioning
Sectional and detail drawings of all components including materials	I	16	36
Lifting plan for all lifting operations (repair, maintenance, etc.)	I	24	36
Limits of coal and high speed diesel properties	I	-	with Bid



Document	Purpose	Weeks after Contract Award	
		Preliminary	Final
• Design calculations of pumps, isolations, piping, etc.	I	12	36
• Water hammer calculation of plant water and cooling water system	I	8	12
• Hydraulic model test procedure of plant water and cooling water systems; institute to perform the tests	A	4	8
• Hydraulic model tests reports of plant water and cooling water systems	A	-	12
• Cooling Tower Recirculation Study	I	-	12
• Sedimentation Study	A	-	12
• Pulverizer performance diagram with pulverizer turn-down range	A	with Bid	12
• Material diagrams for pressure part	A	with Bid	24
• Reference lists with information on successful operating years for: - steam turbines - steam generators - pulverizers - firing systems / burners	A		with Bid
• System description of firing system	A	with Bid	24
• Final correction curves for Plant and equipment performance tests acc. to ASME PTC46 etc.	A		with Bid
Electrical Engineering			
• Electrical single line diagrams	A	with Bid	12
• List of motors and consumers	I	8	every 1 month, final after erection completion
• Electrical equipment sizing calculations (generator main connection, transformers, emergency diesel generators, safe AC and DC power supply, power cables, etc.)	A	12	24
• Cable list	I	16	every 1 month, final after erection completion
• Standard circuit diagrams for all different kinds of electrical	A	12	24

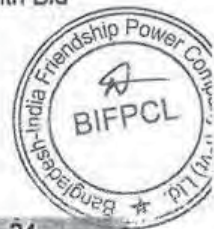

Document	Purpose	Weeks after Contract Award	
		Preliminary	Final
consumers			
• Performance diagram (circle diagrams) of generator	I	with Bid	12
• Circuit diagrams for all individual electrical equipment	I	12	24
• Lists of equipment and devices	I	12	24
• Earthing and lightning plans with calculations	A	12	24
• Lightning protection plans with details of measuring locations and reports of measurements taken following commissioning		12	24
• EMC concept with coordinated overvoltage protection	I	12	16
• Arrangement drawings for switchgear and battery rooms, station service transformers, cable floors, etc.	A	12	24
• Diagram showing power output of plant generator and related transformer vs. ambient temperature from +20 °C to +40 °C	A	with Bid	12
• Block diagram generator/unit protection	A	12	24
• Block diagram AVQC for the generator	A	12	24
• Line plans of fire alarm system if applicable	A	12	24
• Arrangement drawings showing exact location of fire alarm devices if applicable	I	12	24
• Power and lighting installation plans including related calculation	I	16	24
• General arrangement drawings of the required cable trays, cable laying plans	I	12	24
• Dimensional drawings and erection drawings for generator, transformers, switchgear etc., including frontal and plan views	I	12	24
• Dimensional drawings of generator auxiliary equipment	I	12	16
• Dimensional drawings of switching cubicles, generator leads and star point cubicles, voltage regulation cubicles, excitation cubicles, generator circuit breakers, including	I	12	24



Document	Purpose	Weeks after Contract Award	
		Preliminary	Final
equipment configuration			
• Calculation of mechanical stresses of switchgear rooms due to arcing faults	I	12	16
• Short circuit calculation and determination of protection relay settings for generator protection, 400/230 substation and auxiliary electrical supplies under consideration of protection of the entire system	A	12	24
• Protection and metering diagram for unit protection, start-up/stand by transformer protection, 400/230 kV GIS protection	A	16	24
• Load flow, system transient stability and motor start-up study	A	16	24
• Information for electrical system study by PGCB (see relevant part in Section B0)	I	8	16
• Generator charts and exciter characteristics	I	12	16
• Instrumentation and Control Engineering			
• Control system architecture showing all components and design concept redundancy	A	with Bid	24
• Operation and control philosophy	A	8	16
• Design concept earthing	A	16	24
• Design concept explosion protection	A	16	24
• List of packaged systems (Black Boxes)	A	with Bid	24
• Layout drawings central control room showing spatial distribution of desks and panels (3 D view)	A	with Bid (2D only)	24
• Layout of electronic rooms showing spatial distribution of cubicles and racks	A	16	24
• Description for all functional group controls, functional schematics (both in machine language and according to ISA-standard)	A	16	24
• DCS/PLC interface	A	16	24



Document	Purpose	Weeks after Contract Award	
		Preliminary	Final
documentation, I/O point assignment			
• Engineering drawings of control valves, control dampers together with their actuators, orifices, nozzles, venturi nozzles	I	16	24
• External connection diagrams, terminal connection diagrams combined schematic and circuit diagrams	I	16	24
• Communication systems	A	16	24
• As built software programs for DCS, PLC or other systems			1 month after COD of the 1 st Unit
• Instrument list	A	16	24
• Cable routing plan	I	16	24
• Civil Engineering			
• 3D model of the complete Plant incl. all civil structures, all mechanical equipment, piping (> 50mm), electrical equipment (e.g. cable trays, HVAC, etc)	I	16	24
• 3D model clash checking and walk through	A	3 weeks after 3D model distribution	3 weeks after 3D model distribution
• General layout plan of the Plant site including all buildings and outdoor installations, roads etc. prepared on the basis of the topographical survey of the site	A	with Bid	12
• Detailed civil arrangement drawings of all buildings and structures, including plan-views and Sections (scale 1 : 100)	A	with Bid	12
• Architectural views (all sides) for all buildings of the Plant	A	4	12
• Arrangement drawings for external systems including all supply and disposal facilities, roads with manoeuvring areas; outdoor facilities (sewage, drainage, ducts and trenches, fencing and gates; tank farm, outdoor foundations etc.	A	4	24
• Detailed drawings and documents			
• Detailed foundation drawings	I	4	12



Document	Purpose	Weeks after Contract Award	
		Preliminary	Final
for all buildings and structures (A. E., turbine, boiler and stack foundations etc.)			
• Detailed structural drawings for all buildings and structures (concrete and steel structures)	I	8	24
• Detailed architectural drawings	I	8	24
• Room books including external and internal finishes windows, doors, sanitarries wall cladding, roof etc.	A	8	24
• Detailed drawings for all internal services and installation works (HVAC; water, sewage, drainage, lighting)	I	8	24
• Detailed drawings with embedded parts, anchors, plates, fixings etc.		8	24
• Detailed drawings for outdoor installations and services (sewage, drainage; water, ducts, trenches, culverts, pipes, cable routes, manholes, pits etc.)	A	8	24
• Detailed drawings for roads including accesses, footpaths, fencing, gates, landscaping, bridges, pipe racks	A	8	24
• Checked and approved static and dynamical analysis prepared for all buildings and structures of the Plant	I	8	24
• Detailed constructive description of individual buildings with regard to the structural design (structural systems, foundations etc.)	I	8	24
• Sectional elevations and roof plan	I	4	24
• Underground services and ducts with equipment appertaining to the services	I	8	24
• Principal details and Sections for traffic areas, especially for ramps and retaining walls	I	8	24
• Structural drawings pertaining to river water outfall and intake facilities	A	8	24
• Foundation drawings and other underground concrete works	I	4	24



Document	Purpose	Weeks after Contract Award	
		Preliminary	Final
• Permit application documents			
• Documentation for operating permits	A	4	12
• Documentation for other permits	A	4	12
• Other documentation			
• Schedules of workshop tests	I	-	1 month ahead of test
• Quality assurance manuals	I	16	24
• Manual of Codes and Standards	I	16	24
• Operating manual			
• operating procedures and instructions of the Plant with description of all systems, processes and functional groups	A	6 months ahead of pre-commissioning	1 month after COD of the 1 st Unit
• as built documentation			
• general and individual control concept description			
• Plant and equipment protection and signal processing description with all alarm and trip signal settings			
• all operating conditions including electrical grid supply and connection conditions			
• Service and maintenance manual			
• maintenance procedures and instructions with description of all equipment and facilities	A	6 months ahead of pre-commissioning	1 month after COD of the 1 st Unit
• Equipment data sheets			



Purpose: A : for Approval
I : for Information



B0.3.9.3 Data and simulation models

The Tenderer shall submit the data of the Plant for transmission simulation to PGCB according to the Bangladesh Grid Code however minimum following data:

Components	Data	Value of data
Generator step-up transformer	Rating	MVA
	High voltage	kV
	High voltage connection	
	Low voltage	kV
	Low voltage connection	

Components	Data	Value of data
	Positive seq. Impedance	%
	Positive seq. Resistance	%
	Positive seq. Reactance	%
	Zero seq. Impedance	%
	Zero seq. Resistance	%
	Zero seq. Reactance	%
	MVA for base impedance	MVA
	Maximum tap	kV
	Maximum tap position	
	Minimum tap	kV
	Minimum tap position	
	Nominal tap position	
	Value of tap step	
	Core loss	kW
	Copper loss at full load	kW
	Auxiliary power	kW
Generator	Type	
	Manufacturer	
	Rated output	MVA
	Rated voltage	kV
	Connection	
	Inertia constant	
	X _d	%
	X' _d	%
	X _d	%
	X ₂ (Negative sequence)	%
	X ₀ (Zero sequence)	%
	MVA for base impedance	
Turbine	Type	
	Rating	MW
	Inertia constant	
	HP natural frequency and vibration band	Hz
	IP natural frequency and vibration band	Hz
	LP natural frequency and vibration band	Hz
Exciter	Type	
	Range ± % of rated voltage	%
Governor	Type	
	Model No.	
	Droop	%
	Deadband	Hz
Unit auxiliary power consumption	Real power auxiliary load	MW
	Reactive power auxiliary load	MVAR



The Tenderer shall also submit models for simulation studies which are compatible with the software used by PGCB. PGCB is using PSS@E software).

The simulation studies include, but are not limited to:

- a. power flow
- b. short circuit
- c. transient stability.

All characteristics and models shall operate in stable and accurate manner under all frequency range stipulated in this Part B0, including consideration on the following:

- a. large frequency variations upwards (increasing) up to 52Hz,
- b. large frequency variations downwards (decreasing) up to 47.0Hz,
- c. grid system faults,
- d. splitting of the grid system into islands.

All simulation models submitted for stability studies must be in the form of fully validated models for the software used by PGCB simulation. The models shall be provided complete with the following documentations:

- a. model software source codes (fles) as well as object (binary) codes,
- b. description of the models including the engineering of model derivations,
- c. user operation manuals
- d. user application guides
- e. model block diagrams
- f. values of parameters
- g. input data format
- h. criteria for acceptable operation (threshold parameter values such as minimum steam pressure, maximum hydrogen pressure, etc).



The models shall represent closely the on-site response and setting.

Generator and excitation systems

The fully validated control block diagram representation of the software used by PGCB simulation model (including all limiters and power system stabilisers), shall be submitted to PGCB together with:

1. Explanation of all the symbols used
2. Clearly labelled sub-systems of control and protection, such as, Volt/Hz limiter, maximum field current limiter, stator current limiter, minimum field current limiter etc.
3. Input-output relationships, by giving:
 - a) Equations
 - b) Characteristics/Chart/look-up table
 - c) Other input/output relationship (if any).
4. Indication whether the parameters in the block diagram can be measured on the actual system.



Governor

The fully validated control block diagram representation of the software used by PGCB simulation model for the governor systems shall be submitted to PGCB together with:

1. Explanation of all the symbols used
2. Clearly labelled sub-systems of control and protection, such as, additional corrective control against frequency deviations (if any) and other controls (if any).
3. The following variables, states, and limits:
 - a) mechanical output
 - b) generator output
 - c) turbine speed
 - d) mechanical output of steam turbine (ST)
 - e) MW output of ST
 - f) shaft speed of ST
 - g) turbine steam pressure of ST
 - h) turbine steam pressure deviation of ST
 - i) turbine steam temperature of ST
 - j) main control valve position of ST
 - k) intercept valve position of ST
 - l) load limiter signal.
4. Tenderer shall inform values of limits and acceptability (or violation) criteria on the following:
 - a) reverse power (cause reverse power trip when violated)
 - b) Power Load Unbalance (PLU) (or similar) relay trip (if any which cause trip when set criteria is violated)
 - c) operational limits and criteria
 - d) others (if any which cause trip when violated).
5. Tenderer shall inform input-output relationships, by giving
 - a) Equations
 - b) characteristics/chart/look-up tables
 - c) other input/output relationship (if any).
6. Tenderer to inform whether the parameters in the block diagram which exist and can be measured on the actual system.



The above models and documentation shall be submitted in CD-ROM media (read only). One hardcopy of the same is also required to be submitted.

Signature

Due dates and versions for data submission and simulation models are as follows:



Due dates

90 days after signing of this Agreement

90 days prior to the Initial Operation Date of the First Unit

Type of data to be submitted

Committed Project Data

Contracted Project Data

Estimated Registered Data

Due dates	Type of data to be submitted
30 days after the Commercial Operation Date of the First Unit	Registered Data

B0.3.9.4 Requirements for documentation

Unless agreed otherwise, five (5) hard copies and three (3) sets of electronic copies of all documents are to be submitted in the English language. In addition, operation and maintenance manuals shall be translated into Bangla and provided as paper copies and in electronic format. Electronic Copies shall be submitted in primary original data format (e.g. DOC, XLS, DWG) as well as in a printable non-proprietary document format (e.g. PDF). Especially P&IDs shall be submitted as DWG files and PDF files.

The Contractor shall provide, install, operate and maintain a web based electronic data room / data server. The format and filing system shall be mutually agreed between Employer and Contractor.

All documentation shall comply with uniform documentation instructions according to Employer's requirements. Detailed requirements for documentation will be determined during contract execution by the Employer.

Contractor shall comply with Employer's directive concerning documentation requirements for implementation in an automated plant operation system.

The final documentation including but not limited to operating manuals, maintenance and service manuals, component documentation, assembly documentation, drawings and listing, etc. shall be submitted in the English language. In addition, operation and maintenance manuals shall be translated into Bangla and provided as paper copies and in electronic format.

Contractor shall also integrate and submit all the above data for each Unit into the PSS@E load flow raw data file ("raw data") and PSS@E dynamic raw data file ("dyr data") which are ready to be used for studies on operation and planning of the Grid System by PGCB using PSS@E (to be confirm by PGCB/BIFPCL)

Data for each Unit shall also include reactive power capability curve of the Facility, written in the format compatible to PSS@E activity GCAP. For this purpose, at least 10 (ten) pairs of data on the generator reactive power capability curve shall be provided for each Unit.

The final requirements for Transmission lines and Interconnecting Facilities documentation will be subjected to PGCB's approval which will be made known during execution stage.



B0.3.9.5 Approval procedure for drawings and documents

The Employer reserves the right to ask the Contractor to submit drawings and other documents for approval to the Employer or to its representative.

Before submittal of any such drawing or other document, the Contractor shall submit a detailed list comprising all drawings or other documents the Contractor will produce. Based on this list the Employer will decide which drawings or other documents will have to be submitted for approval, information or other purpose.

The documents for approval are primarily basic documents and all documents that are required to check that Contractual and operational requirements are met. It is expected that in total approximately 600 to 800 documents will be for approval.

When submitting drawings or other documents for approval, including any prepared by subcontractors, the Contractor shall certify in each case that he has examined such drawings or documents and that they comply with the requirements of the Contract.

The Contractor is requested to provide Third Party Verification of structural documents, e.g. structural analysis, drawings and connecting details prior to submission for approval. These documents must contain all information necessary for the execution of the works.

Approval of a drawing or other document will imply that:

- They have been examined and appear to be in accordance with the basic design concept of the project and meet the requirements of the specification.
- They have been examined in relation to compatibility of the items and equipment with the specification and respect of interconnections with other items, equipment or systems.
- The Contractor is not relieved of his responsibility under the Contract.

The Contractor is to arrange for the revision history of drawings and other documents as follows. The first revision shall be indexed by the letter "A" followed up by the respective letter in alphabetical order.

Once the drawing or document is approved for construction by the Employer or its representative the document shall be indexed with the number "0" followed up by the respective number in chronological order. Hence, the sequence of the revision index of a design document shall be as follows: A - B - C - [...] - 0 - 1 - 2 - [...]. Each revision is to be listed in the revision history with the respective date and a short description of the modification(s). In addition, all modification(s) shall be highlighted and/or marked up as specific and detailed as possible.



Furthermore, each drawing/document shall be indicated with a unique document number according to the following standard:

Maitree – Unit – KKS – DCC - 12345 – XYZ - REV

Where:

Maitree	Project-Denomination
Unit -	00 (for common), 01 (for unit 1), 02 (for unit 2)
KKS -	Function Key as per KKS system (1 to 3 letters)
DCC -	DCC code according to EN/IEC 61355
12345 -	Document number
XYZ -	Sub-/Contractor number
REV -	Revision index

For each comment, the Employer will allocate a priority in the TCS (Technical Comment Sheet). The priorities range from 1 to 3 as follows:

1	-	High Priority
2	-	Medium Priority
3	-	Low Priority

The TCSs are to be named with the above described identification key and the supplementary ending "... - RI" ("Revision Income") for TCSs being sent from the Contractor to the Employer and "... - RO" ("Revision Outcome") vice versa.

The Contractor shall be responsible for any discrepancies, errors or omissions in the drawings and other documents supplied by him, whether such drawings or other documents have been approved or not.

B0.3.9.5.1 Documents which require Approval from Grid Operator/BPDB

Documents especially test procedures and protocols, which are due to approval by the grid operator or BPDB required following specific times for submittal and approval.

B0.3.9.5.1.1 Testing Procedure and Protocols

At least one hundred and twenty (120) Days before the scheduled commencement of the testing and Commissioning of the Plant, the Contractor shall, upon request from BPDB, submit to BPDB detailed procedures and protocols to be used during the corresponding testing. BPDB shall have the opportunity to provide written comments, if any, on the proposed procedure and protocols within thirty (30) Days of receipt from the Contractor of said documentation. If BPDB fails to submit written comments to the Contractor within the thirty (30) Days stipulated above, it shall be deemed to have accepted the detailed procedure and protocols provided by the Contractor.



On receipt of such comments, if any, the Contractor shall review and submit the final procedure and protocols, to be used for testing not later than sixty (60) Days prior to the scheduled commencement of the respective testing and Commissioning:

- a. if BPDB fails to submit written comments to the Contractor within the thirty (30) Days stipulated above, it shall be deemed to have accepted the detailed procedure and protocols provided by the Contractor; and 35
- b. if the Parties fail to reach agreement on the procedures and protocols within sixty (60) Days prior to the scheduled commencement of the respective testing and Commissioning,

the matter may be referred to the Engineer by either Party, and the Engineer shall make the decision on the protocol and procedures within the five (5) Days of the matter being referred to it, and such decision shall be binding on the Parties.

B0.3.9.5.1.2 Start-up and Test Schedules

At least ninety (90) Days before the scheduled commencement of testing and commissioning of the First Generating Unit or the Plant, as the case may be, the intended Start-Up and test schedule for such unit.

B0.3.9.5.1.3 Operating Procedures

- a. Not later than one hundred and twenty (120) Days before the then prevailing Scheduled Initial Operations Date, the Contractor shall, upon request from BPDB, provide BPDB with draft operating procedures dealing with all operation interfaces between BPDB and the Contractor including, but not limited to:

- method of Day-to-Day communication
- key personnel list
- clearances and switching practices
- outage scheduling
- capacity and energy reporting
- operating log; and
- reactive power support

which shall be consistent with this Agreement, the designs of the Facility (including the Metering System), the Technical Limits and Prudent Utility Practices (together, the "Operating Procedures").

- b. Within thirty (30) Days after BPDB's receipt of the draft Operating Procedures, BPDB shall notify the Company of any requested deletions, amendments or additions.



- c. The Company shall make any deletions, amendments or additions that BPDB reasonably requests unless they would be inconsistent with this Agreement, the Technical Limits, the designs of the Facility (including the Metering System), or Prudent Utility Practices and provide such revised draft to BPDB, which shall be treated as final Operating Procedure, not later than thirty (30) Days before the then prevailing Scheduled Commercial Operations Date.
- d. Not Used
- e. Either Party may, from time to time, request revisions to the Operating Procedures subject to agreement from the other Party.

B0.3.9.6 Quality control procedure

A comprehensive **quality control procedure / quality assurance programme** for all aspects of the works shall be prepared by the Contractor and shall be submitted to the Employer for approval.

The Contractor shall adopt suitable quality assurance programme (QAP) to ensure that the equipments and services under the scope of Contract whether manufactured or performed within Contractor's works or at his subcontractor's premises or at the site or at any other place of work are in accordance with the specifications. Such QAP shall be outlined by the Contractor and shall be finally accepted by the Employer or his authorized representative after discussions before the start of work. The QAP shall be generally in line with ISO Systems.

The quality assurance program shall consist at least of the following:

- testing during manufacturing
 - workshop inspections and testing
 - factory acceptance tests (FAT)
- testing at site
 - construction inspections and testing
 - erection / mechanical completion
 - pre-commissioning and commissioning tests (cold and hot commissioning)
 - optimization of overall Plant
 - final inspection and testing
 - Bench mark testing
- completion test
 - performance tests
 - reliability test run.



An outline of the proposed comprehensive quality assurance programme is to be provided with the Tender and is subject to review by the Employer.

The Contractor shall provide complete laboratory facilities and staff to perform the required tests. The facilities could be fully or partially on site. Arrangements could be made with an experienced testing laboratory to support the site laboratory, all subject to the approval of the Employer.

Only approved fully qualified and experienced staff shall carry out the quality control all in accordance with the approved quality control procedure.

The Contractor shall appoint a dedicated, experienced and competent QA&QC in-charge at site, preferably directly reporting to the project manager, supported as necessary by experienced personnel, to ensure the effective implementation of the approved QAP. An indicative structure of Contractors QA&QC manpower required to be deployed at site shall be submitted with the Tender.

The results of the tests shall be made available to the Employer within 24 hours of obtaining the relevant test results. Acceptance of the relevant part of the work shall be subject to the performed tests showing satisfactory results. Individual construction completion certificates shall be issued by the Contractor to certify the readiness for equipment erection (see Section B0).

The Employer may instruct tests at no cost provided either the overall frequency governed by the specification is not exceeded and the notification given to the Contractor is equal to that currently being provided by the Contractor for his normal testing in formality and warning, or the Employer has due cause to suspect a change in the quality, such concern having been advised to the Contractor. The Employer may instruct sampling, testing or both which satisfy only some or none of the above criteria.

The Employer shall have the right to carry out independent inspections and testing either using his own resources or those of a third party. Should the Employer require the results to determine the conformance with the specification then he shall notify and inform the Contractor.

As far as is practicable the Employer shall have free access to the site, fabrication areas and suppliers work at all times without notice. Should he discover unsatisfactory work then he will invite a formal joint inspection. Either after such an inspection or if the Contractor declines the invitation the Employer shall issue instructions with regard to the faults and their reparation.

Should any materials, items or complete parts of the works fail to comply with the requirements of this specification when tested in accordance with this Section the Employer may reject such materials or items, or condemn complete parts of the works, and demand of the Contractor such replacement or modification as may be necessary to ensure their compliance.



Should modification or adjustment be deemed a satisfactory alternative to demolition and /or removal, the Contractor shall submit full details in writing such modifications to the Employer for approval, and should such approval be forthcoming carry them out without undue delay.

If however, the Contractor is required to demolish and /or remove any such items or materials this shall be carried out quickly and with as little disruption to the works as possible.

No claims of any sort whatsoever will be entertained arising from the rejection of any part of the works through failure to meet this specification, and repairs, demolitions, removals, additional testing etc. Such modifications, removal, demolitions etc, shall be entirely at the expense of the Contractor. No extension of the Contract period shall be granted for such a reason.

If for any reason materials or other items are received or made on site before approval of them has been granted, these shall be transported, handled and stored separately or labelled in such a way in order to, wherever possible, prevent them being incorporated into the works or, should such prevention not be possible, to accurately define the part(s) of the works in which such materials or items were used.

Approvals previously granted for any materials etc. shall be withdrawn if they are not properly transported, handled or stored and otherwise protected against weather or contaminants which may adversely affect their properties and subsequent performance. The Contractor has the option of removing such materials or having them retested for approval.

The Contractor shall submit to Employer, the quality plans and field welding schedules (for field weld of pressure parts only), along with test procedures and WPS endorsed by designer wherever applicable, for checks to be done during manufacturing and erection, for review and approval by Employer.

B0.3.10 Options and Alternatives

B0.3.10.1 Option 3.1: Absorber made of concrete (Optional Offer)

Refer to Amendment No. 1, B3.

B0.3.10.2 Option 3.2: Combined Limestone System for Both Units (Optional Offer)

Refer to Amendment No. 1, B3.



B0.3.10.3 Option 4.1: Open coal stock yard (Optional Offer)

Refer to Amendment No. 1, B4.

B0.3.10.4 Option 4.2: Screw unloader (Optional Offer)

Refer to Amendment No. 1, B4.

B0.3.10.5 Option 4.3: Open limestone yard (Optional Offer)

Refer to Amendment No. 1, B4.

B0.4 Interfaces

The Contractor shall actively clarify all interfaces with the Employer, the Operator, PGCB and all companies, authorities and any other entity participating in the project.

B0.4.1 Battery limits of the plant

The interfaces for the Plant shall be as follows.

The Contractor shall actively clarify all details of the interfaces with the Employer, the grid operator (NLDC), the coal supplier, the fuel oil supplier, the limestone supplier and all other interfacing companies.

All mentioned equipment, connections, connection materials, counter flanges, shut-off valves, safety valves, seal up material and works are included in the scope of supply:

Designation	Category	Interface / Terminal Points
TP1	HV overhead transmission line (OHL)	<ul style="list-style-type: none"> 400 kV and 230 kV OHL conductors on the gantries for connection of the related GIS bushings. OHL conductors for connection of the Line Traps. <p>The Connection from the generator transformer to the 400/230 kV GIS shall be included in the Bidder's/Contractor's scope of supply. The 400 kV and 230 kV transmission OHL for power evacuation will be provided by PGCB. The limit of supply is at the take-off gantries (to be supplies by the Bidder/Contractor) for the 230/400 kV OHL For detailed scope refer to Section B10.3.3 and B10.3.5.</p>
TP2	OHL Protection	<ul style="list-style-type: none"> None



Designation	Category	Interface / Terminal Points
		<i>Remark: The 400 kV and 230 kV OHL protection on the Power Plant end (not on the remote end) shall be included in the scope of supply of the Maitree-STPP Project.</i>
TP3	OHL Telecommunication	<ul style="list-style-type: none"> • Terminals on the line traps for connection of the telecommunication equipment provided by PGCB on the related gantries • Terminals in the telecommunication panels provided by PGCB and located in the control building of the 400/230 kV GIS for connection of the cables for the signal exchange with the PGCB/NLDC and for the teleprotection. • Terminals in the telecommunication panels provided by PGCB and located in the control building of the 400/230 kV GIS for connection of the cables for auxiliary/control power supply (240V AC, 220 VDC and 48VDC). <p>The cabling between Contractor's cubicles and the telecommunication equipment provided by BPDB in the Control Building of the 400/132 kV GIS shall be in the scope of the Bidder/Contractor.</p>
TP4	Earthing and	<ul style="list-style-type: none"> • Terminals on the gantries for connection of the OPGW • Earthing bars in the control building of the 400/230 kV GIS for connection the protection and telecommunication panels.
TP5	Plant water intake	Intake from Possur river, all required supplies and services in scope
TP6	Plant water discharge	Discharge to Possur river, all required supplies and services in scope
TP7	Coal supply	Coal unloader at jetty (all coal vessel berthing, mooring and unloading facilities within scope of supplies and services)
TP8	Fuel oil supply	At and including Fuel Oil Truck Unloading Station near the Power Plant. All supplies and services in scope The road truck unloading station shall be positioned in the vicinity of the storage tank. Accordingly TP8 is located at the near of HSD oil storage tank. However, the unloading station is included in the scope of the Bidder
TP9	Limestone supply	Coal unloader at jetty (all coal vessel berthing, mooring and unloading facilities within scope of supplies and services) (common equipment with coal supply)



Designation	Category	Interface / Terminal Points
TP10	Fly ash	Outlet connection at: <ul style="list-style-type: none"> • ship loading from fly ash storage silos • Truck loading from fly ash storage silos • Truck loading from intermediate fly ash silos • ash pond All supplies and services in scope Complete ship loading system from silo with all accessories shall be in Bidder's/Contractor's scope
TP11	Bottom ash	 Outlet connection at: <ul style="list-style-type: none"> • Truck loading from bottom ash storage silos • Truck loading from intermediate bottom ash silos • ash pond All supplies and services in scope Complete ship loading system from silo with all accessories shall be in Bidder's/Contractor's scope.
TP12	Gypsum	Outlet connection at: <ul style="list-style-type: none"> • ship loading from gypsum storage silos • Truck loading from gypsum storage silos • Truck loading from intermediate gypsum silos All supplies and services in scope Complete ship loading system from silo with all accessories shall be in Bidder's/Contractor's scope
TP13	Raw water supply	Pipeline 1 m outside Plant boundary; interface with raw water supplier
TP14	Sewage water	Discharge to Passur river
TP15	Storm water	Discharge to Passur river, outside the Plant area; all required supplies and services in scope
TP16	Waste water for discharge	Discharge to Passur river There shall be no spill water from ash dyke to be discharged to Passur River without treatment. Seepage water from the ash dyke shall be recirculated to overflow lagoon with suitable drainage and pumping system.
TP17	Waste water and scheduled waste for disposal	Interconnection to facility external disposal
TP18	Chemicals supply	Chemicals receiving facility
TP19	Township 11 kV Power supply	Terminals in the 11 kV unit board of the Power Plant For the supply of the township redundant 11 kV feeders (2 x 100%), one from the 11 kV unit boards of each unit, shall be provided as

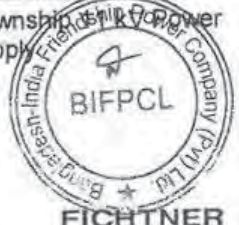

FICHTNER 000096  B0-82

Designation	Category	Interface / Terminal Points
TP20	Construction Power	<p>per section B7.1.1. Cables and raceways are out of Bidder's/Contractor's scope of supply, however, sufficient free space to be considered by the Bidder/Contractor for later installation of associated cables and raceways towards township area.</p> <p>2 terminals at 33 KV line at the border of the Power Plant Site</p> <p>Construction Power (Please refer to Section V.TS/B9/B9.4.2.1)</p> <p>Power supply for construction purposes will be provided at 33 KV voltage (2 no. of lines). The same will be extended to the Contractor for him to develop 33/11 KV sub-stations and construction power supply comprising of</p> <ul style="list-style-type: none"> • Two (2) 5 MVA, 33/11KV step-down transformers. • Two (2) 11 KV switchgears • 11 KV mainring, design according to plant layout, construction requirement and schedule. • 11KV/4.15 KV step-down transformers (number and sizes as required according to plant layout, construction requirement) • Two (2) 11 KV feeders (minimum 630 A) for usage of the Employer. <p>For improved reliability these feeders shall be connected to separate 11 KV bus systems at 33/11 KV sub-stations.</p> <p>The electricity prices/power tariffs for the case of 33 KV voltage level are defined in the Annex C.</p> <p>Further preliminary details regarding provided construction power system are shown in Annex C.</p>



Construction Water:

As described under Section B9 the supply of construction water is in the scope of Bidder/Contractor. It is not allowed to use ground water. For construction water shall be used only river water suitably treated for his purposes.



B0.4.2 Interfaces to electricity dispatcher

Communication, control, monitoring and voice channels will be provided between the Facility and BPDB's National/ Regional Control Center by BPDB. The Contractor shall provide interconnection within the Facility for all such communication circuits/ channels.

B0.4.2.1 Interface between the Power Plant and the NLDC

In order to link the Plant to the 400 kV PGCB National Load Dispatch Center (NLDC) the Contractor shall make available all analogue and digital signals in accordance with the requirements of the Bangladeshi Grid Code and as requested by PGCB and the Employer. These will include command signals from the NLDC to the Plant's automatic load control systems (AGC, see **Part B8**).

The Contractor shall liaise with NLDC to facilitate necessary interfacing with the SCADA System in NLDC. All necessary firmware and software with suitable communication link through serial interface (to match the protocol of the existing system) shall be provided by the Contractor. Necessary reconfiguration is to be done by the Contractor to establish logical link with the existing SCADA system in NLDC. Further, reconfiguration of the database and various display builder functions of the SCADA system in NLDC to accommodate additional signals are under the scope of work of the Contractor.

The following reserve requirements shall be taken into account:

- Min. 10% of the equipment installed shall be a reserve to enable handling of an additional 10% of signals without the need for equipment extensions.
- Min. 15% of the equipment installed shall be a reserve to enable handling of an additional 15% of signals by extending the equipment but without the need to modify the existing structure of any of the interface marshalling cubicles installed.



B0.4.2.2 Signal interface to NLDC for automatic generation control

The power plant shall be equipped with terminals to receive command from the BPDB load dispatch center to allow control from NLDC.

The NLDC shall be able to link to the Automatic Generation Control (AGC) via telecontrol facilities so as to act on the turbine load control, adjusting the latter by decrease/increase load commands. All measurement data to indicate if the target load has been matched shall be transmitted by the telecontrol system to NLDC. Type and initial number of signals are defined in **Section B8**.

B0.4.2.3 Interfaces between the 400/230kV substation and the NLDC

The Contractor (in consultation with BPDB) shall provide suitable interface unit for communication links to the PGCB's SCADA system for communication, control, monitoring and voice channels to accommodate the PGCB and the National/ Regional Control Center requirements.

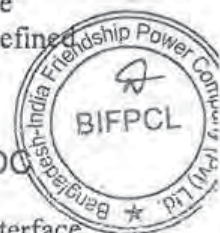

The communication interface unit shall be adequate to fulfil the PGCB/ NLDC information requirement. Communication to the National Load Dispatch Center shall be provided by data communication, utilizing both, the IEC 60870-5-104 and the IEC 60870-5-101 protocols. Settings shall ensure interoperability with the remote National Load Dispatch Center.

For possible future extensions, it shall be possible to interface with two remote control centers simultaneously by using dual port capability.

From the National Load Dispatch Center, all related high voltage apparatus of the substations shall be remote controlled and monitored. Necessary interface shall be provided within the substation automation system for receiving the signals from PGCB grid control.

All signals of the substation required for the control and monitoring from the remote National Load Dispatch Center shall be made available for data transmission via the gateway.

The scope of supply includes all required equipment and installations to enable the substation for the proper connection of the required control and monitoring signals. Communication, telemetry, fiber optical terminal and tele-protection equipment (PLCC) will be supplied and installed by PGCB at Company substation end matching with PGCB's remote substation end requirements. However, line trap and capacitive voltage transformer of required rating along with 48 VDC/AC auxiliary supply at Company substation end shall be provided by the Contractor. The Contractor shall supply and install the necessary cabling and cubicles. Cabling between these cubicles and the telecommunication equipment provided by PGCB shall be provided and installed by the Contractor.

The cabling between Contractor's cubicles and the telecommunication equipment provided by PGCB in the Control Building of the 400/230 kV GIS shall be in the scope of the Bidder/Contractor.

B0.4.2.4

Interfaces between the 400/230kV substation and the Power Plant

The Contractor is responsible for the construction of the interconnections between the substation and the Power Plant. Provision and installation of all control and signal cables between the substation and the Power Plant is within the responsibility of the Contractor.

The Power Plant shall be able to supervise and control the substation via an OPC client workstation installed in the Power Plant's CCR. The Contractor shall provide and install the OPC Server/Client architecture as well as all necessary equipment required for the proper translation of the native data (either acquired directly from the IEDs or from connectivity with the station bus) in OPC-format and the data provision at the OPC-client in the Power Plant control room via a TCP/IP communication link.

