

LIME STONE WEIGH FEEDER & PNEUMATIC DIVERTER ALONG WITH ACCESSORIES FOR KAHALGAON WBM.

This specification stipulates the requirements for design, engineering, manufacturing, cleaning coating, painting, inspection, testing, packing, forwarding, delivery at site, site painting (if any), supervision of erection, testing, commissioning, performance guarantee test at shop/site, liquidation of punch points of '**Belt Weigh Feeder & Pneumatic diverter along with accessories** 'with all equipment and auxiliaries

Bidder shall refer Document No.BA89162 for qualification requirement.

1. GENERAL DESCRIPTION OF WEIGH FEEDER

The duct from the limestone silo hopper feeds the limestone to the weigh feeder. The weigh feeder feeds limestone to Wet ball mill system.

Sl. No.	Description	Requirement
1.	Quantity and Design Capacity of Feeder	
	Quantity and Design Capacity of Feeder	34TPH –2 sets
2.	Parameters	
	Media to be Handled	Limestone
	Limestone Analysis	Refer Annexure -1
	Duty	Continuous

2.SCOPE OF WORK

Scope for the bidders shall include Design, Engineering, Manufacture, Inspection/testing as per approved quality plans, Packing, Supply, Supervision of Erection & Commissioning, Performance Guarantee Test and handing over of final Customer.

- a. Design:** Includes basic engineering, detail engineering, preparation and submission of engineering drawings/calculations/datasheets/quality assurance documents/field quality plans, storage instructions, commissioning procedures, Erection & assembly Drawings, operation & maintenance manuals,

COPYRIGHT AND CONFIDENTIAL
The information on this document is the property of BHARAT HEAVY ELECTRICALS LIMITED, It must not be used directly or indirectly in any way detrimental to the interest of the company.

REVISION See record notes of revision	PREPARED BY P V S B	APPROVED BY AMAN SURIN	DATE 04.07.2022
--	------------------------	---------------------------	--------------------

106-1 Rev No. 5	Form No.		PRODUCT STANDARD PULVERISERS HYDERABAD		Product STD no.	BA89262	
				Rev No.	00		
				Page	2 of 16		
COPYRIGHT AND CONFIDENTIAL The information on this document is the property of BHARAT HEAVY ELECTRICALS LIMITED, It must not be used directly or indirectly in any way detrimental to the interest of the company.		<p>performance guarantee test procedures and assisting BHEL in obtaining time bound approval from NTPL.</p> <p>b. Testing: The scope of the bidder includes all shop tests, type tests, site tests, routine tests etc., fulfilment of complete quality assurance & inspection requirement and related activities for all the equipment & systems covered under the scope of the bidder.</p> <p>c. Painting: The bidder scope of work includes supply of paints and painting of all equipment's as per approved painting schedule from NTPC/BHEL. Approved painting schedule will be provided after award of contract. Tentative painting schedule attached</p> <p>d. Supervision of Erection & commissioning: Includes supervision of erection & commissioning, supervision of startup and trial operation.</p> <p>Performance Guarantee Test: The guarantee tests shall be carried out as per approved Performance guarantee test procedure, all the special equipment, tools and tackles, instruments, measuring devices required for successful conductance test shall be provided by bidder free of cost.</p> <p>3.. Scope of Supply: The scope of supply shall include but not limited to the following.</p> <p>3.1.Mechanical:</p> <ol style="list-style-type: none"> One number of Spool Piece (Above Rod Gate) One number of Rod Gate One number of Spool Piece (Below Rod Gate) One number of Spool Piece Between Slide Gate and Feeder Inlet One number of Belt Weigh Feeder (one number below each limestone day silo) each of capacity specified in clause No.1 complete with variable speed drive and its controls to achieve the capacity from 0 to 100% load, load cell, belt, pulleys, idlers, drive motors, brakes, coupling, coupling guard, complete drive unit, supporting frame along with stools, feeding and discharge chute, belt tensioning arrangement, belt cleaners, dust tight enclosure, pull chord switches, belt sway and zero speed switches, inserts, fasteners, weighing and calibration devices, speed sensor, device for loss of flow detection, local control system etc. including all mechanical, electrical, C&I and structural parts and accessories. Limestone weighing shall be automatic and shall include local & remote indication of rate of flow& totalizer counter. 					
REVISION See record notes of revision		PREPARED BY P V S B	APPROVED BY AMAN SURIN	DATE 04.07.2022			

106-1 Rev No. 5	Form No.		PRODUCT STANDARD PULVERISERS HYDERABAD		Product STD no.	BA89262
				Rev No.	00	
				Page	3	of 16
COPYRIGHT AND CONFIDENTIAL The information on this document is the property of BHARAT HEAVY ELECTRICALS LIMITED, It must not be used directly or indirectly in any way detrimental to the interest of the company.		<p>f) Distance Piece: Feeder discharge hood and discharge chute up to Inlet flange of wet ball mill.</p> <p>g) One number of Motorised gates at feeder inlet</p> <p>h) One number of Motorised gates at feeder outlet</p> <p>i) One number of pneumatic diverter gate.</p> <p>j) One number of mill inlet chute.</p> <p>k) One number of bypass chute.</p> <p>l) Equipment fittings, supporting structure, along with insert plates, fixing bolts, MS sleeves, base plates, grouting and proper alignment etc.</p> <p>3.2 Electrical & Control instruments</p> <p>a) Cables, Cable glands ,Local electrical control panels, JB'S, transmitter, Motors with terminal boxes, VFD with accessories (cable sizing, cable race way and cable procurement between VFD and VFD operated motor) , Cable trays/conduits with supporting system .</p> <p>b) All the necessary Control & field instrumentation i.e. Transmitters, process actuated switches pull cord switches, belt sway switches, zero speed switches, Under Belt Switch, Chute Blockage Switch ,limit switches, switch for loss of flow, sensors, final control elements, solenoid / motor operated valves, etc. as per finally approved P&ID/Flow Scheme, and to facilitate effective control of the system, shall be supplied by Bidder.These shall suit the actual FGD DDCMIS</p> <p>c) All transmitters, gauges etc. shall be suitably grouped together and mounted inside:</p> <p style="padding-left: 40px;">(i) Local Instruments Enclosures (LIEs) in case of open areas</p> <p style="padding-left: 40px;">(ii) In Local Instrument Racks (LIRs) in case of covered areas.</p> <p style="padding-left: 40px;">Instrument rack / enclosure shall be free standing type with CRCA steel and painting</p> <p>d) Belt Weigh feeder shall be controlled through either through microprocessor based DDCMIS, supplied by Employer or local control panel based on bidder's standard practice. However, in case of control through LCP, start / stop command with necessary control and monitoring feedback (Hard wired) shall be provided by bidder from LCP to DDCMIS. Detailed operation and control philosophy shall be furnished by bidder and the same shall be subject to</p>				
REVISION See record notes of revision		PREPARED BY P V S B	APPROVED BY AMAN SURIN	DATE 04.07.2022		

106-1 Rev No. 5	Form No.		PRODUCT STANDARD PULVERISERS HYDERABAD		Product STD no.	BA89262
				Rev No.	00	
				Page	4 of 16	
COPYRIGHT AND CONFIDENTIAL The information on this document is the property of BHARAT HEAVY ELECTRICALS LIMITED, It must not be used directly or indirectly in any way detrimental to the interest of the company.		<p>purchaser / owner's approval during detailed engineering.</p> <p>e) Two (2) number of pull-cord switches shall be provided at both side along the length of each belt conveyor, which shall enable the respective conveyor to be stopped immediately. Each pull chord switch shall be identified by a specific number on HMI in the main control room. All instruments/JB/racks shall be tagged as per Purchaser's tagging philosophy.</p> <p>f) Scope of C&I Cable and Cable engineering: From field instruments/ valves/ devices to JB's – Bidder's scope. From JB's/field instruments/valves/ devices to Bidder's supplied Local panels- Bidder's scope</p> <p>g) For DDCMIS preparation of logic/loops in case of operation from DDCMIS, I/O list, Drive list, Instrument List, mimics/ displays etc. shall be provided by Bidder for implementation in DDCMIS for Belt weigh feeder.</p> <p>h) Temperature transmitter, pressure transmitter and motorized actuators shall be compatible with DCS All actuators shall be certified for SIL 2 or better.</p> <p>***Profibus protocol communication to followed for this project.</p> <p>3.3 Scope of Supply - Civil & Structural:</p> <p>Structural loading drawings indicating the vertical and lateral loads transmitted to the foundation at each support location. The loads due to dead load, live load, wind load, seismic load and other pertinent conditions shall be listed separately. This shall include, but not be limited to, magnitude, direction of forces; location, service, and / or connection details to Purchaser's furnished supports. All such drawings shall be submitted under separate cover. Overall base plate dimensions and Anchor bolt information shall include the size and location of bolts in relation to equipment center-line, anchor bolt projection above concrete surface, bolt material strength, and required length. Levelling provisions shall be fully described.</p> <p>BIDDER shall submit design calculations, which include the determination of operating loads, foundation reactions and anchorage design.</p> <p>**Bidder shall supply any other items required for completeness of the equipment except the items covered in the exclusions.</p> <p>4 .Miscellaneous Scope:</p>				
		REVISION See record notes of revision	PREPARED BY P V S B	APPROVED BY AMAN SURIN	DATE 04.07.2022	

106-1 Rev No. 5	Form No.		PRODUCT STANDARD PULVERISERS HYDERABAD		Product STD no.	BA89262
				Rev No.	00	
				Page	5 of 16	
COPYRIGHT AND CONFIDENTIAL The information on this document is the property of BHARAT HEAVY ELECTRICALS LIMITED, It must not be used directly or indirectly in any way detrimental to the interest of the company.		<ol style="list-style-type: none"> I. All equipment, systems and components etc. supplied under this specification shall be fully designed and engineered by Supplier. II. Supply of all consumables like chemicals, lubricants required for start-up and commissioning, trial runs, performance guarantee test and up to handing over of the complete plant to the Employer by the Purchaser including first fill of lubricants. The first fill requirement same includes oils and lubricants for one-year toppings. III. Supply of all Start-up and commissioning spares Bidder shall quote for recommended spares, if any, as an optional item. IV. Special tools & tackles, which are necessary or convenient for erection, commissioning and overhauling of any equipment. V. Testing instruments during commissioning and performance guarantee testing at site shall be provided by the Bidder and provision for install of these items to be provided. VI. All equipment, systems and components mentioned under this specification shall be technically complied with codes/standards, technical requirements and technical datasheet to meet the mentioned guaranteed requirements. Bidder shall fully own the responsibility of functional requirement of equipment covered in this specification. VII. Inspection and testing for all equipment and components at Bidder's works and his sub-vendor's works shall be as per approved QAP, applicable codes and approved drawing/documents/procedures. VIII. Supervision of Erection and Supervision of commissioning of all equipment and system under scope of this package. For Erection and commissioning requirements. IX. Supervision of Performance guarantee testing as specified elsewhere in the specification. X. Bidder shall be responsible for establishment of overall performance of the System/equipment supplied under this contract. Bidder shall provide qualified technical field personnel & testing equipment/instruments as required for commissioning, testing and as well as for establishment of performance parameters at site. Any additional work (if required) on equipment and accessories/associated systems to establish performance parameters as per 				
REVISION See record notes of revision		PREPARED BY P V S B	APPROVED BY AMAN SURIN	DATE 04.07.2022		

106-1 Rev No. 5	Form No.		PRODUCT STANDARD PULVERISERS HYDERABAD		Product STD no.	BA89262
				Rev No.	00	
				Page	6 of 16	
COPYRIGHT AND CONFIDENTIAL The information on this document is the property of BHARAT HEAVY ELECTRICALS LIMITED, It must not be used directly or indirectly in any way detrimental to the interest of the company.		<p style="text-align: center;">the specification/Purchaser/Employer observation shall be performed by the Bidder without any commercial and schedule implication to Purchaser.</p> <p>5 Equipment Functional Guarantee</p> <p>I. Bidder shall provide minimum availability of Belt Weigh Feeder as minimum 98%.</p> <p>6 .Other Services</p> <p>a) Training of Employer’s Personnel :</p> <p>The Bidder’s supervisory personnel at site shall train adequate number of Employer’s operation and maintenance personnel at site during erection and commissioning of equipment to enable them to take over proper operation and maintenance of the equipment after commissioning.</p> <p>b) Shop inspection and Test Procedures</p> <p>The Equipment’s covered by this specification shall be subjected to inspection and testing. The Bidder shall provide all services to establish and maintain quality of workmanship in his works and that of his sub-Vendors to ensure the mechanical accuracy of components, compliance with drawings, identification and acceptability of all materials, parts and equipment.</p> <p>c) Quality plan shall submit after award of contract. Bidder shall follow quality plan approved by BHEL/Customer</p> <p>d) Packaging for Transportation</p> <p>All the equipment’s shall be suitably protected, coated, covered or boxed and crated to prevent damage or deterioration during transit till the time of erection. While packing all the materials, the limitation from the point of view of the sizes of railway wagons available in India should be taken.</p> <p>The Bidder shall be responsible for any loss or damage during transportation due to improper packing.</p> <p>Preservative coatings used on components shall be suitable for the conditions normally expected during shipping, storage and throughout the erection period.</p> <p>Each type of preservative used shall be identified as to quality, life expectancy and type. Toxic and hazardous-type preservatives shall not be allowed. Complete information shall be submitted to the Purchaser covering step-by-step procedures,</p>				
REVISION See record notes of revision		PREPARED BY P V S B	APPROVED BY AMAN SURIN	DATE 04.07.2022		

106-1 Rev No. 5	Form No.		PRODUCT STANDARD PULVERISERS HYDERABAD		Product STD no.	BA89262	
				Rev No. 00			
				Page 7 of 16			
COPYRIGHT AND CONFIDENTIAL The information on this document is the property of BHARAT HEAVY ELECTRICALS LIMITED, It must not be used directly or indirectly in any way detrimental to the interest of the company.		<p>including federal, state and local governing controls for handling and removal of each type of preservative. This information shall be submitted six months prior to delivery.</p> <p>The Bidder shall indicate the Weights and dimensions of each component, which shall be shipped along with the offer.</p> <p>7 .EXCLUSION:</p> <p>Broad terminal points have been indicated in the tender specification. Within these terminal points, all equipment and electrical distribution, piping network, control and instrumentation etc. as required shall be furnished by the Bidder unless specifically excluded as follows:</p> <p>7.1 Mechanical</p> <ol style="list-style-type: none"> I. Limestone Day Silo and its supporting structure. II. Wet ball mill III. All concrete foundations and RCC works (if applicable). <p>7.2 Electrical</p> <ol style="list-style-type: none"> I. Main LT power supply II. Lightning System. <p>7.3Control & Instrumentation</p> <ol style="list-style-type: none"> I. FGD DDCMIS and its associated RIOP Cabinets, Data highway, Workstation II. Cabling between local JB/LCP to FGD DDCMIS III. Fire Detection & Alarm System <p>7.4 CIVIL:All concrete foundations and RCC works,</p> <p>8. TERMINAL POINTS</p> <p>The following are the Bidder's battery limits:</p>					
REVISION See record notes of revision		PREPARED BY P V S B		APPROVED BY AMAN SURIN		DATE 04.07.2022	



PRODUCT STANDARD

PULVERISERS HYDERABAD

Product
STD no.

BA89262

Rev No. 00

Page 8 of 16

8.1 MECHANICAL

Sl. No.	System / Equipment	Bidder's Battery Limits / Purchaser's Connection
1.	Limestone receipt	Limestone day silo shall be provided by Purchaser. Bidder scope starts from the Discharge flange of Silo. Counter flange, gasket, fasteners and seal shall be supplied by bidder
2.	Limestone Discharge	Bidder's scope terminates at the limestone discharge at wet ball mill material inlet. Counter flange, gasket, fasteners and seal shall be supplied by bidder

8.2 ELECTRICAL

The following are the Bidder's battery limits:

Sr.No.	System/Equipment	Bidder's Battery Limit / Purchaser's Connection
1	VFD	a. Terminals for Main incoming power cable b. Terminals for control cable interface c. Earthing terminal
2	Local Push Button Station (LPBS) if any provided by bidder	a. Control terminals b. Earthing terminals on LPBS enclosure

8.3 Control & Instrumentation

Sr.No.	System/Equipment	Bidder's Battery Limit / Purchaser's Connection
1.	Outgoing cables to FGD DDCMIS	Belt weigh feeder local JB/LCP terminals
2.	Power supply to C&I equipment/items	Purchaser will be provide the 230V AC UPS/Non UPS or 24V DC power to equipment / instruments at one end and further distribution through distribution box (PDB) of power supply to instruments / actuators will be in bidder's scope of supply.

REVISION
See record notes of revision

PREPARED BY
P V S B

APPROVED BY
AMAN SURIN

DATE
04.07.2022

106-1 Rev No. 5	Form No.		PRODUCT STANDARD PULVERISERS HYDERABAD		Product STD no.	BA89262
				Rev No. 00		
				Page 9 of 16		
COPYRIGHT AND CONFIDENTIAL The information on this document is the property of BHARAT HEAVY ELECTRICALS LIMITED, It must not be used directly or indirectly in any way detrimental to the interest of the company.						
3,	Earthing	Earthing of bidder supplied panels by bidder to nearest earthing JB including earthing JB.				
<p style="text-align: center;">9. CODES AND STANDARDS</p> <p>All equipment, systems and services covered under this specification shall comply with all currently applicable statutory regulations and safety codes in the locality where the equipment will be installed. The equipment and systems shall also conform to the latest applicable standards specified. All codes and standards referred to in the specification shall be understood to be the latest version on the date of offer made by the Bidder unless otherwise indicated. Nothing in this specification shall be construed to relieve the Bidder of this responsibility.</p> <p>Bureau of Indian standards (BIS)</p> <p>Japanese Industrial Standards (JIS)</p> <p>American National Standards Institute (ANSI)</p> <p>American Society of Mechanical Engineers (ASME)</p> <p>American Society for Testing and Materials (ASTM)</p> <p>American Petroleum Institute (API)</p> <p>American water works association. (AWWA)</p> <p>Standards of the Hydraulic Institute, USA</p> <p>International Organisation for Standardisation (ISO)</p> <p>Tubular Exchanger Manufacturer's Association (TEMA)</p> <p>American Welding Society (AWS)</p> <p>National Electrical Manufacturers Association (NEMA)</p> <p>National Fire Protection Association (NFPA)</p> <p>International Electro-Technical Commission (IEC)</p> <p>Expansion Joint Manufacturers Association (EJMA)</p> <p>Heat Exchange Institute (HEI)</p> <p>IEEE Standard</p> <p>JEC Standard</p> <p>Occupational Safety & Health Administration (OSHA)</p> <p>American Standard Association (ASA)</p>						
REVISION See record notes of revision		PREPARED BY P V S B		APPROVED BY AMAN SURIN		DATE 04.07.2022

106-1 Rev No. 5	Form No.		PRODUCT STANDARD PULVERISERS HYDERABAD		Product STD no.	BA89262	
				Rev No. 00			
				Page 10 of 16			
<p style="writing-mode: vertical-rl; transform: rotate(180deg);"> COPYRIGHT AND CONFIDENTIAL The information on this document is the property of BHARAT HEAVY ELECTRICALS LIMITED, It must not be used directly or indirectly in any way detrimental to the interest of the company. </p> <p> Uniform Building Code (UBC) American Institute of Steel Construction (AISC) Steel Structures painting Council (SSPC) State Elevator and Escalator Act State Elevator and Escalator Rules Indian Electricity Act. Indian Electricity Rules. </p> <p>10 DESIGN AND CONSTRUCTION REQUIREMENTS</p> <p>10.1 Mechanical</p> <p>Belt Weigh feeder shall be designed as per the requirement specified in Tender document.</p> <p>All parts in contact with limestone except belt shall be of stainless steel construction.</p> <p>Belt feeders shall be positively self-cleaning and have dust tight construction. It shall be provided with flanged belt, rubber lagged head pulleys and inspection doors. No chain/belt drives shall be accepted.</p> <p>The limestone feeder belt shall be of seamless rubber construction. It should be possible to adjust the belt tension from outside without opening the feeder body.</p> <p>The feeder shall have adequate instrumentation to detect 'loss of flow'.</p> <p>The feeder shall have a motor/pneumatic operated gate at the outlet.</p> <p>There shall be no reduction of section in the bunker outlet chute from bunker to feeder. The inlet chute shall be provided with suitable poke doors/holes in order to remove jamming/blockage.</p> <p>10.2 Electrical</p> <p>All the electrical work and supply shall be as per tender requirements. This specification is intended to broadly define design base of electrical system equipment required for control, operation, protection and monitoring of this package.</p> <p>10.3 C&I</p>							
REVISION See record notes of revision		PREPARED BY P V S B		APPROVED BY AMAN SURIN		DATE 04.07.2022	

106-1 Rev No. 5	Form No.		PRODUCT STANDARD PULVERISERS HYDERABAD		Product STD no.	BA89262	
				Rev No. 00			
				Page 11 of 16			
<p style="writing-mode: vertical-rl; transform: rotate(180deg);"> COPYRIGHT AND CONFIDENTIAL The information on this document is the property of BHARAT HEAVY ELECTRICALS LIMITED, It must not be used directly or indirectly in any way detrimental to the interest of the company. </p> <ul style="list-style-type: none"> • Primary instruments like microprocessor based transmitters employing HART protocol, thermocouples & RTD's along with temperature transmitters, pressure/diff pressure/temperature/flow*ultrasonic/electromagnetic) transmitter & gauges. • Integral to equipment which are not indicated in the tender drawings, but are required for control, monitoring and operation of the equipment for which no P&ID is attached shall be provided to meet the actual system requirements and meeting redundancy and other technical specifications. • For binary and analog inputs required in major equipment's of FGD system, protection triple-sensing devices shall be provided. Binary and analog inputs, which are required for protection of more than one equipment as well as protection signals for HT drives etc., triple sensing devices shall be provided. • For other critical binary and analog inputs required for protection and interlock purpose of other equipment (Eg. Those interlocks which may lead to loss if production, non-availability of major equipment etc.,) triple sensors shall be provided • Temperature elements, electronic transmitters etc., are to be provided for all the cases. Use of process actuated switches is acceptable only in case indicated in tender drawings. • Redundancy in instrumentation shall be designed by the Bidder, to ensure that malfunction of any single instrument shall not lead to loss of any Major Auxiliary (all HT Drives and Critical LT drives) or loss of Generation or loss of control function or loss of protection function. Bidder shall also ensure that Loss/ Malfunction of any single sensor shall not jeopardize the safety of the equipment. • All instruments supplied by the Bidder shall be of proven type. In the event of any instrument/ system not working satisfactorily as per the intent of the specification within performance guarantee period in spite of best attention by the Bidder, the Bidder shall replace them with a good one to the satisfaction of Purchaser. The items/ systems so replaced by the Bidder shall have the same guarantee for satisfactory performance starting from the date of replacement without any commercial & schedule implication. <p>PAINTING REQUIREMENTS</p>							
REVISION See record notes of revision		PREPARED BY P V S B		APPROVED BY AMAN SURIN		DATE 04.07.2022	

106-1 Rev No. 5	Form No.		<p align="center">PRODUCT STANDARD</p> <p align="center">PULVERISERS</p> <p align="center">HYDERABAD</p>		Product STD no.	BA89262																			
					Rev No. 00																				
					Page 12 of 16																				
<p align="center">COPYRIGHT AND CONFIDENTIAL</p> <p>The information on this document is the property of BHARAT HEAVY ELECTRICALS LIMITED, It must not be used directly or indirectly in any way detrimental to the interest of the company.</p>		<p>Painting shall be followed as per approved painting scheme. However, for components where no specific requirement is stipulated, the painting conforming to the requirements stipulated below shall be as per OEM practice.</p>																							
		<p>11. Documents Submission:</p> <p>11.1 Documents along with offer</p> <p>Bidder shall submit the following drawings/data and technical information along with their Techno-commercial offer</p>																							
		<table border="1"> <thead> <tr> <th>Item</th> <th>Description</th> </tr> </thead> <tbody> <tr> <td>1.</td> <td>General arrangement drawing of belt weight feeder</td> </tr> <tr> <td>2.</td> <td>Quality assurance plan(QAP)</td> </tr> <tr> <td>3.</td> <td>Published equipment brochures and documents</td> </tr> <tr> <td>4.</td> <td>Experience/installation list of similar projects</td> </tr> <tr> <td>5.</td> <td>Other vendor supplied supporting documents</td> </tr> <tr> <td>6.</td> <td>Warranty & performance guarantee schedule</td> </tr> <tr> <td>7.</td> <td>Sub vendor list</td> </tr> <tr> <td>8.</td> <td>Guaranteed auxiliary power consumption</td> </tr> <tr> <td>9.</td> <td>Complete electrical load list .</td> </tr> </tbody> </table>				Item	Description	1.	General arrangement drawing of belt weight feeder	2.	Quality assurance plan(QAP)	3.	Published equipment brochures and documents	4.	Experience/installation list of similar projects	5.	Other vendor supplied supporting documents	6.	Warranty & performance guarantee schedule	7.	Sub vendor list	8.	Guaranteed auxiliary power consumption	9.	Complete electrical load list .
Item	Description																								
1.	General arrangement drawing of belt weight feeder																								
2.	Quality assurance plan(QAP)																								
3.	Published equipment brochures and documents																								
4.	Experience/installation list of similar projects																								
5.	Other vendor supplied supporting documents																								
6.	Warranty & performance guarantee schedule																								
7.	Sub vendor list																								
8.	Guaranteed auxiliary power consumption																								
9.	Complete electrical load list .																								
		REVISION See record notes of revision	PREPARED BY P V S B	APPROVED BY AMAN SURIN	DATE 04.07.2022																				

COPYRIGHT AND CONFIDENTIAL
 The information on this document is the property of BHARAT HEAVY ELECTRICALS LIMITED,
 It must not be used directly or indirectly in any way detrimental to the interest of the company.

11.2 Documents along with offer

Bidder shall submit the following drawings/data and technical information along with after award of contract. For approval or Information:

Item	Description
1.	Data Sheet & General arrangement drawing of belt weight feeder
2.	Quality assurance plan(QAP)
3.	Utility Consumption & Lubricating Oil List
4.	Equipment sizing & Motor sizing calculations
5.	Sub vendor items documents & quality plans
6.	Sub vendor list
7.	GA Drawings with dimensional details of all offered panels
8.	Complete electrical load list .
9.	loading details(static and dynamic loads) Drawing, Anchor Bolts, mounting plates static & dynamic details
10.	Cross sectional drawings
11.	VFD and Motor Data Sheet and type test report(as applicable)
12.	Erection and commissioning manual
13.	Performance test procedures
14.	Shop inspection and test procedures
15.	Operation and maintenance manual in a comprehensive manner prepared for use by operating and maintenance personnel.(3 sets)

- MDL shall be finalized with the successful Bidder after award of contract.

106-1 Rev No. 5	Form No.		PRODUCT STANDARD PULVERISERS HYDERABAD		Product STD no.	BA89262
					Rev No.	00
					Page	14 of 16
COPYRIGHT AND CONFIDENTIAL The information on this document is the property of BHARAT HEAVY ELECTRICALS LIMITED, It must not be used directly or indirectly in any way detrimental to the interest of the company.		<ul style="list-style-type: none"> Other drawings as may be required will be determined at a later date. Descriptions in the drawings, in the documents, and in the displays shall be in English. Bidder shall submit instruction manual for all the equipment's covered under the scope of bidder as per agreed engineering schedule. The instruction manuals shall contain full details required for erection, commissioning, operation and maintenance of each equipment. The manual shall be specifically complied for this project. The erection portion of manual shall contain erection strategy, sequence of erection, erection instructions, critical checks (along with permissible deviations/tolerance), Bill Of Materials, procedure for erection, general safety procedures to be followed. Procedure for initial checking after erection, procedure for testing (along with acceptance norms) check list for commissioning/pre-commissioning activities, List of tools and tackles. All the manuals shall be two rim PVC bound stiff sided binder able to withstand constant usage. The cover shall be printed with project name. 				
		<p>13. SUPERVISION OF ERECTION, TESTING AND COMMISSIONING</p> <ul style="list-style-type: none"> The erection of Belt Weigh Feeder & Pneumatic diverter along with accessories will be done by owner (BHEL) as per Erection Manual and check List provided by bidder. The bidder has to supervise for erection, pre-commissioning & post-commissioning check-up, start-up, trial runs of all the items covered under the scope of supply. There will be two visits per each weigh feeder assembly totally there will be 4 visits. The bidder will be informed well in advance for the visit. Bidder shall consider 15 working days per weigh feeder assembly. In case erection and commissioning activities get delayed due to any account, resulting into overstay of vendor supervisory engineer beyond schedule time, then BHEL shall pay for additional man-day stay of vendor supervisory engineers. Vendor to quote Per day cost for deputation along with this offer. TA/DA, boarding and lodging shall be borne by the bidder and shall be inclusive in supervision charges portion. Charges for supervision of Erection & commissioning shall be quoted by the bidder. Price comparison for evaluating the lowest bid will be considered all main supply, supervision of E&C charges and mandatory spares price all together. 				
REVISION See record notes of revision		PREPARED BY P V S B	APPROVED BY AMAN SURIN	DATE 04.07.2022		



PRODUCT STANDARD

PULVERISERS

HYDERABAD

Product
STD no.

BA89262

Rev No. 00

Page 15 of 16

****Confirmation shall be taken from BHEL during detail engineering for Mating flange and interface details accordingly vendor drawing shall be updated.**

14. Guarantee/ Warranty Requirement:

- 18 months from the date of commissioning or 24 months from the date of supply whichever is early

ANNEXURES LIST:

Annexure Sl. No.	Description
1.	Lime stone properties
2.	Deviation list.
3.	Vendor scope of items drawing
4.	Wet ball mill and Day silo GA drawing
5.	Painting Schedule
6.	FEEDER contract specification
7.	MOTOR SPECIFICATION
8.	VFD specification
9.	CABLES
10.	Electrical Actuators
11.	Indicative vendor list
12	MANDATORY SPARES

VARIANTS – TABLE

VARIANT NO.	DESCRIPTION	MATEIRAL CODE
00	LGS WEIGH FEEDER & PNEMUNA DIV 34T KAH	BA9789262000
01	LIME STONE FEEDERS BELT	BA9789262019
02	ME STONE FEEDER BELT DRIVE MOTOR	BA9789262027
03	LIME STONE FEEDERS BELT DRIVE REDUCER	BA9789262035
04	LGS FEEDERS SPEED REDUCER ASSEMBLY	BA9789262043
05	LIME STONE FEEDERS WEIGHING INSTRUMENTS	BA9789262051
06	LIME STONE FEEDERS FEEDER WEIGHING ROLL	BA9789262060
07	GRAVIMETRIC FEEDER GATE ACTUATOR ASSY	BA9789262078
08	LGS COUNTER ASSEMBLY OF FEEDER COMPLETE	BA9789262086
09	LGS FEEDER HEAD PULLEY ASSEMBLY	BA9789262094
10	SWITCHES ALL TYPES	BA9789262108

REVISION
See record notes of revision

PREPARED BY
P V S B

APPROVED BY
AMAN SURIN

DATE
04.07.2022

12	ELECTRONIC PCB OF ALL TYPES	BA9789262124
13	ABSOLUTE ENCODER (REPLACEABLE PART)	BA9789262132
14	ELECTRONIC TORQUE SENSOR	BA9789262140
15	ACTUATORS	BA9789262159

RECORD OF REVISIONS

REV. NO	DATE	REVISION DETAILS	REVISED	APPROVED

COPYRIGHT AND CONFIDENTIAL
 The information on this document is the property of BHARAT HEAVY ELECTRICALS LIMITED,
 It must not be used directly or indirectly in any way detrimental to the interest of the company.

Analysis of limestone, water & instrument air**Lime-Stone:****Absorbent**

Absorbent Name	LIMESTONE
Grain Size	Medium
Bond Index	13kWh/short-ton

Type of Absorbent	<input checked="" type="checkbox"/> Rock <input type="checkbox"/> Powder <input type="checkbox"/> Slurry <input type="checkbox"/> Others :
-------------------	---

Feed Condition to Absorber	<input type="checkbox"/> Powder <input checked="" type="checkbox"/> Slurry 30 wt% <input type="checkbox"/> Others :
----------------------------	--

Absorbent Composition		Limestone			Note
		Design	Normal	Guarantee	
CaCO ₃	wt%-d	79 (*1)	-	89 (*1)	
Dolomite(MgCa(CO ₃) ₂)	wt%-d	0	-	0	
Inert	CaO	wt%-d	47-51.0 (*1)	-	-
	MgO	wt%-d	0.9-2.0	-	-
	Cl ₂	wt%-d	<0.015	-	-
	Al ₂ O ₃	wt%-d	1.19-2.1	-	-
	Si ₂ O ₃	wt%-d	2.1-4.5	-	-
	Fe ₂ O ₃	wt%-d	0.45-1.0	-	-
	TiO ₂	wt%-d	<0.02	-	-
	Na ₂ O	wt%-d	<0.16	-	-
	K ₂ O	wt%-d	<0.01	-	-
	P ₂ O ₅	wt%-d	Traces	-	-
	LOI	wt%-d	39.0-41.3	-	-
	Total Sulphur	wt%-d	<0.1	-	-
	Mn ₂ O ₃	wt%-d	<0.12	-	-
Density	kg/m ³	1400			For volume
	kg/m ³	1700			For torque, drive calculation and structural load calculation

N/D : Not detectable

(*1) Design condition limestone purity CaCO₃ 79%; Guarantee condition limestone purity CaCO₃ 89%

Process Water:

		CW Blow down water (*1)			
		Normal (Stg-I)	Normal (Stg-II)	Maximum	
Temperature at B.L.	deg.C	27	27	45	
Pressure at B.L.	MPaG	-	-	-	
pH	-	6.5-6.9	6.5-6.9	-	
S.S.	mg/l	-	-	-	
Composition					
	Ca ²⁺	ppm CO ₃ Ca	237	316	-
	Mg ²⁺	ppm CO ₃ Ca	219	292	-
	Na ⁺	ppm CO ₃ Ca	195	260	-
	K ⁺	ppm CO ₃ Ca	18	24	-
	Oil and Grease	mg/l	-	-	-
	N ₂ H ₄	mg/l	-	-	-
	HCO ₃ ⁻	ppm CO ₃ Ca	-	-	-
	CO ₃ ²⁻	ppm CO ₃ Ca	-	-	-
	Cl ⁻	ppm CO ₃ Ca	189	252	-
	SO ₄ ²⁻	ppm CO ₃ Ca	120	160	-
	Silica	mg/l	45	60	-
	To-NH ₄	mg/l	-	-	-
	Fe ²⁺	mg/l	0.36	0.48	-
	Cd	mg/l	-	-	-
	NO ₃ ⁻	ppm CO ₃ Ca	6.6	8.8	-
	B	mg/l	-	-	-
	To-Inorganic	mg/l	-	-	-
	Cu	microg/l	-	-	-
	Hg	microg/l	-	-	-
	Pb	microg/l	-	-	-
	NO ₂ ⁻	microg/l	-	-	-
	F ⁻	microg/l	-	-	-
	Cr ⁶⁺	microg/l	-	-	-
	Ni	microg/l	-	-	-
	To-Zn	microg/l	-	-	-
	BOD5	mg/l	-	-	-
	COD Cr	mg/l	-	-	-
	Total alkalinity	ppm CO ₃ Ca	120	120	-
	Total Hardness	ppm CO ₃ Ca	-	-	-
	Turbidity	NTU	4.5	6	-
	Conductivity	micro m/m	-	-	-

(*1)CW blow down water Analysis is taken from tender documents Amendment No:CS-0011-109(3)-9-AMDT-TECH-01 & Annexure

Cooling Water**Cooling Water**

Water Source		DM Water					
		Available Value			Design Value		
		Minimum	Normal	Maximum	Minimum	Normal	Maximum
Supply Temp. at TP	deg.C	-	-	-	-	38	-
Return Temp. at TP	deg.C	-	-	-	-	45	-
ΔT	deg.C	-	-	-	-	10	-
Supply Press. at TP	MPaG	-	-	-	-	0.6(*1)	-
Return Press. at TP	MPaG	-	-	-	-	0.3(*1)	-

(*1) Assumed value

Instrument Air:

Air Source		-					
Dew Point (atmospheric)	deg.C	≤ -40					
Oil Mist Contamination		<input type="checkbox"/> Contaminated <input checked="" type="checkbox"/> Not Contaminated					
		Available Value			Design Value		
		Minimum	Normal	Maximum	Minimum	Normal	Maximum
Temperature at TP	deg.C	-	-	-	-	45(*1)	-
Pressure at TP	MPaG	-	-	-	0.55	-	0.8

(*1) In summer

Service Air

Air Source		-					
		Available Value			Design Value		
		Minimum	Normal	Maximum	Minimum	Normal	Maximum
Temperature at TP	deg.C	-	-	-	-	45(*1)	-
Pressure at TP	MPaG	-	-	-	0.55	-	0.8

(*1) In summer

Annexure-2

Project Name :ENQ/ NIT No: _____(Vendor to fill & submit along with offer)

LIST OF DEVIATIONS/ EXCEPTIONS (IF ANY, vendor to fill and submit along with offer)

SI No	Clause No	Page No	Description of Deviation

Note: Enlarge the table to incorporate items

SIGNATURE OF BIDDER -----

NAME -----

DESIGNATION -----

FIRST ANGLE PROJECTION

(ALL DIMENSIONS ARE IN mm)

DRG. NO. 3-62-221-00062

THE INFORMATION ON THIS DOCUMENT IS THE PROPERTY OF BHARAT HEAVY ELECTRICALS LTD. IT MUST NOT BE USED DIRECTLY OR INDIRECTLY IN ANY WAY DETRIMENTAL TO THE INTEREST OF THE COMPANY.

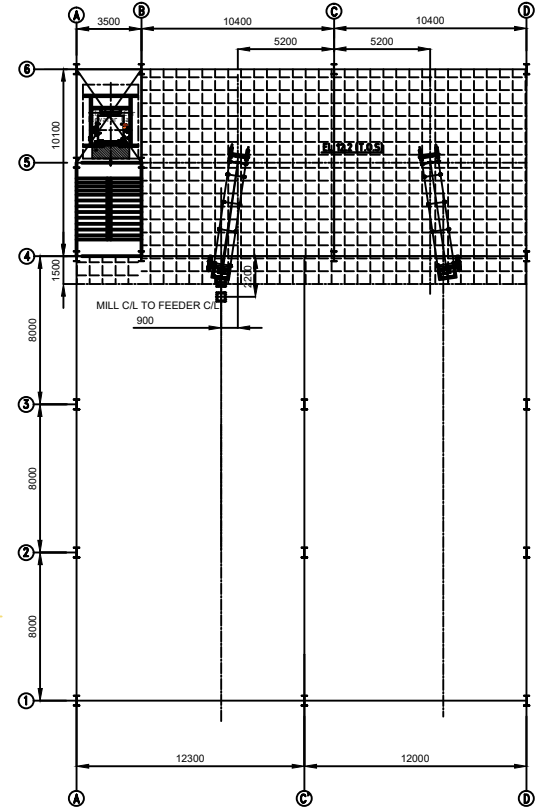
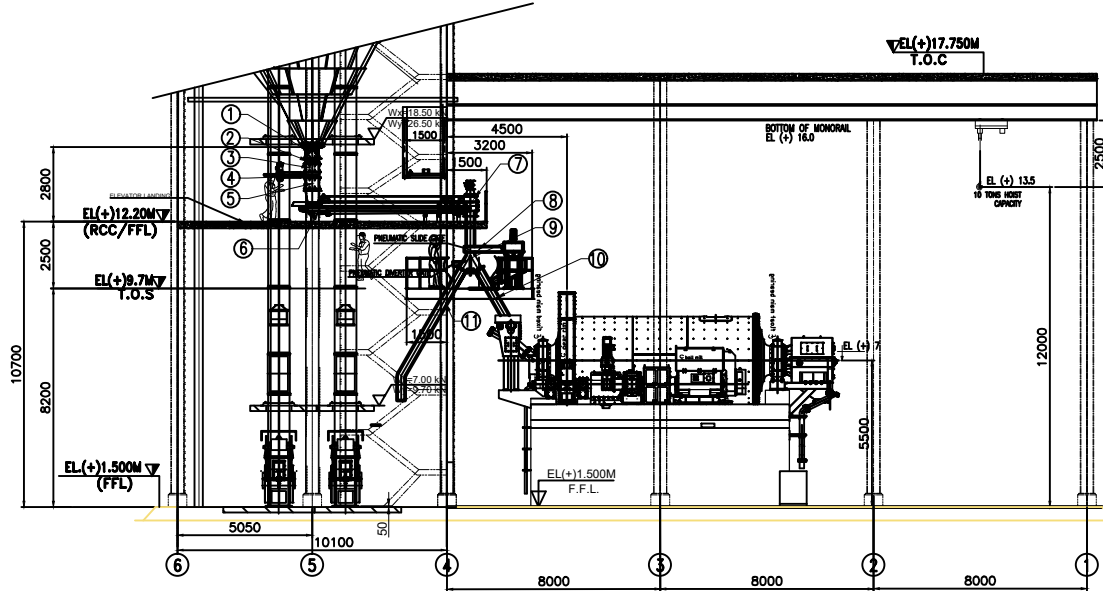

PLAN VIEW OF EL(+12.2M).
FEEDER FLOOR

ITEM LIST AND SCOPE		
SL. NO	DESCRIPTION	SCOPE
1	SPOOL PIECE (ABOVE ROD GATE)	VENDOR
2	ROD GATE	VENDOR
3	SPOOL PIECE (BELOW ROD GATE)	VENDOR
4	MOTORIZED SLIDE GATE ABOVE FEEDER	VENDOR
5	SPOOL PIECE BETWEEN SLIDE GATE AND FEEDER INLET	VENDOR
6	WEIGH FEEDER	VENDOR
7	DISTANCE PIECE	VENDOR
8	MOTORIZED SLIDE GATE BELOW FEEDER	VENDOR
9	PNEUMATIC DIVERTER GATE	VENDOR
10	BYPASS CHUTE	VENDOR
11	BALL MILL INLET CHUTE	VENDOR

THE FOLLOWING CONDITIONS APPLY EXCEPT OTHERWISE STATED...

- REF. TO HY0230261 FOR UNSPECIFIED TOLERANCES.
- CHAMFER M/CD SHARP EDGES 1.2 TO 1.0 AT 45°.
- INTERNAL M/CD CORNER RADII 1 TO 0.7.
- THE SURFACE ROUGHNESS WHEREVER NOT SHOWN SHALL BE TAKEN FROM THE SURFACE ROUGHNESS SHOWN OUT SIDE BACK SLASHES GIVEN AT THE TOP MOST RIGHT CORNER OF THE DRG.

TYPE OF PRODUCT OR NAME OF CUSTOMER/PROJECT **KHALGAON STPP (4X210MW+3X500MW) FGD SYSTEM PACKAGE**

	DRN.	BGK	SIGN.	DATE	NO. OF VAR.
	CHD.	PVSB		29.09.22	
	APPD.	AMAN SURIN		29.09.22	

DEPT. PULV ENGG.	SCALE NTS	WEIGHT (KG) --	REF. TO ASSY DRG.	ITEM NO. 01	NO. OF ITEMS
CODE 446					

TITLE	DRAWING NO.	REV.
WEIGH FEEDER ALONG WITH ACCESSORIES	3-62-221-00062	00
	SHEET NO. 01	NO OF SHEETS 01

INVENTORY NO.	REV. DATE ALTERED		REV. DATE ALTERED	
	CHD.	APPD.	CHD.	APPD.
ZONE			ZONE	

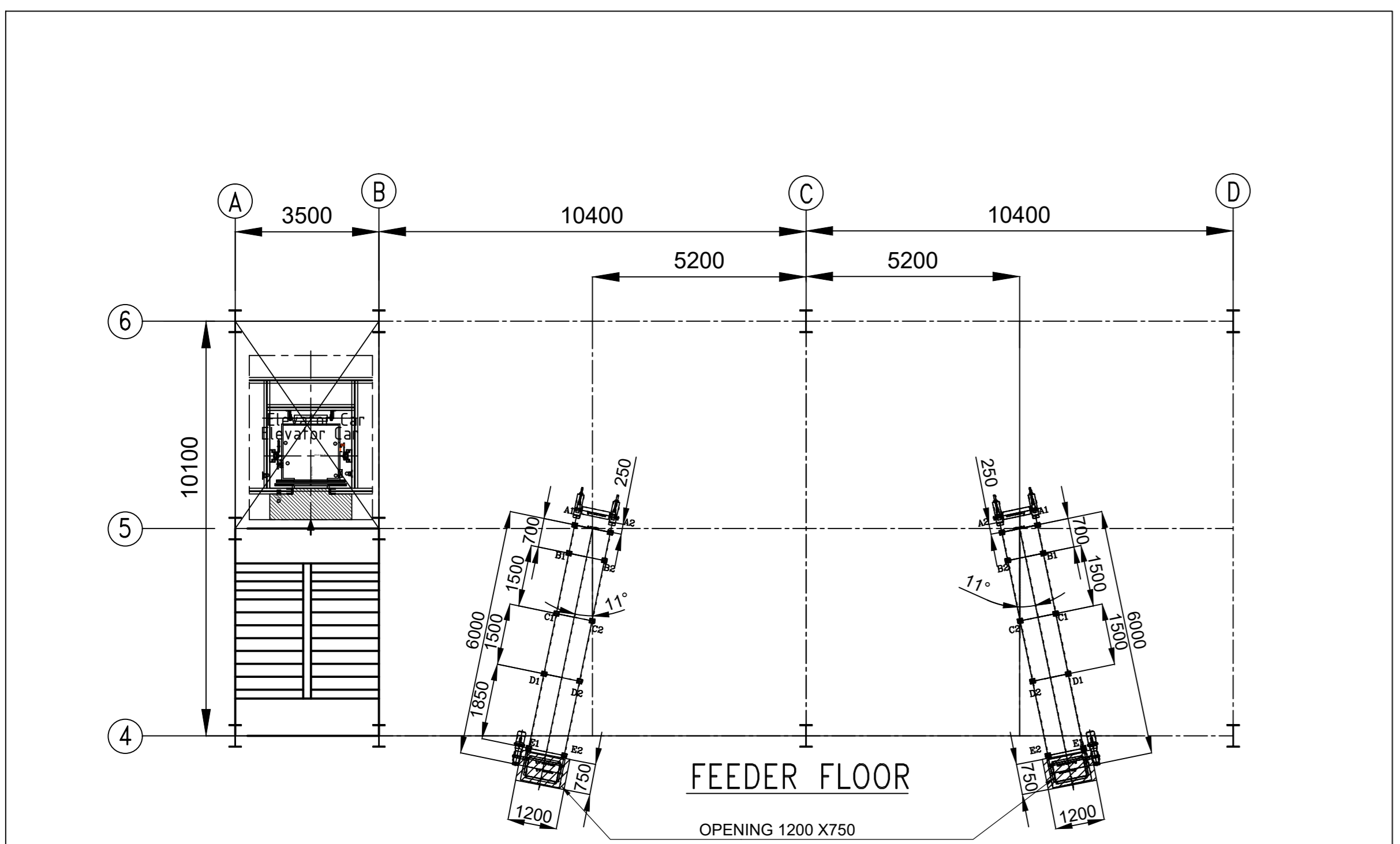
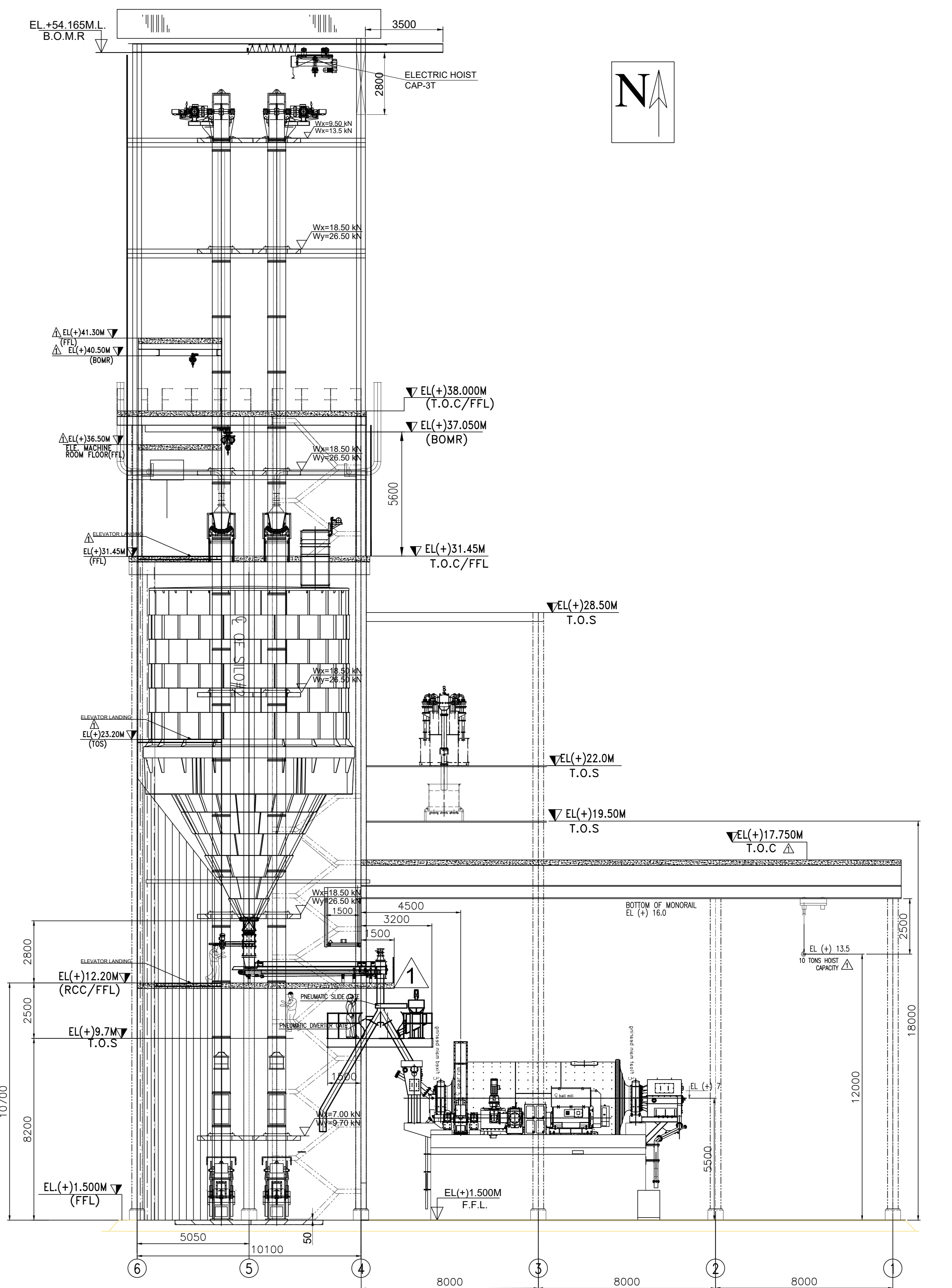
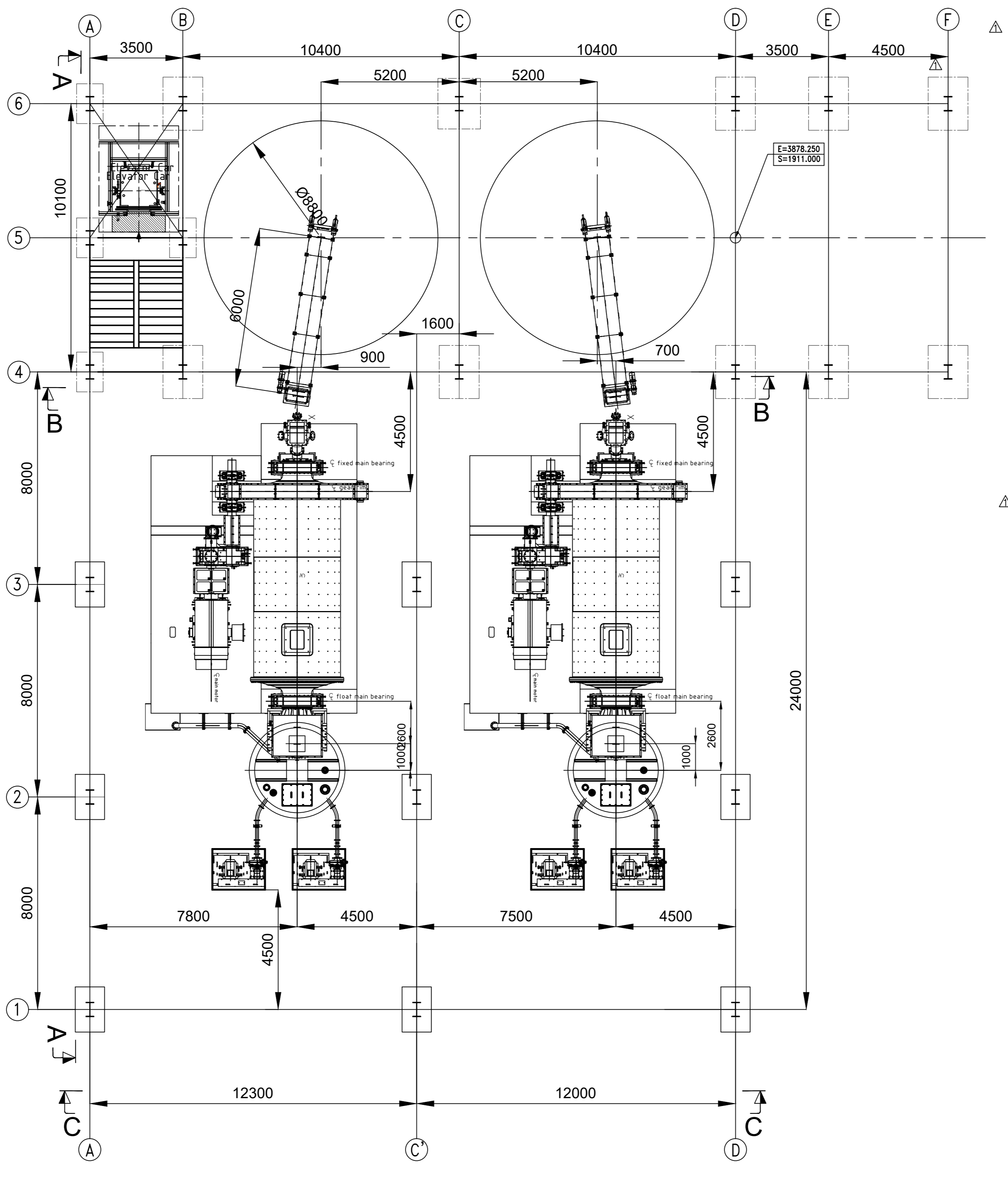
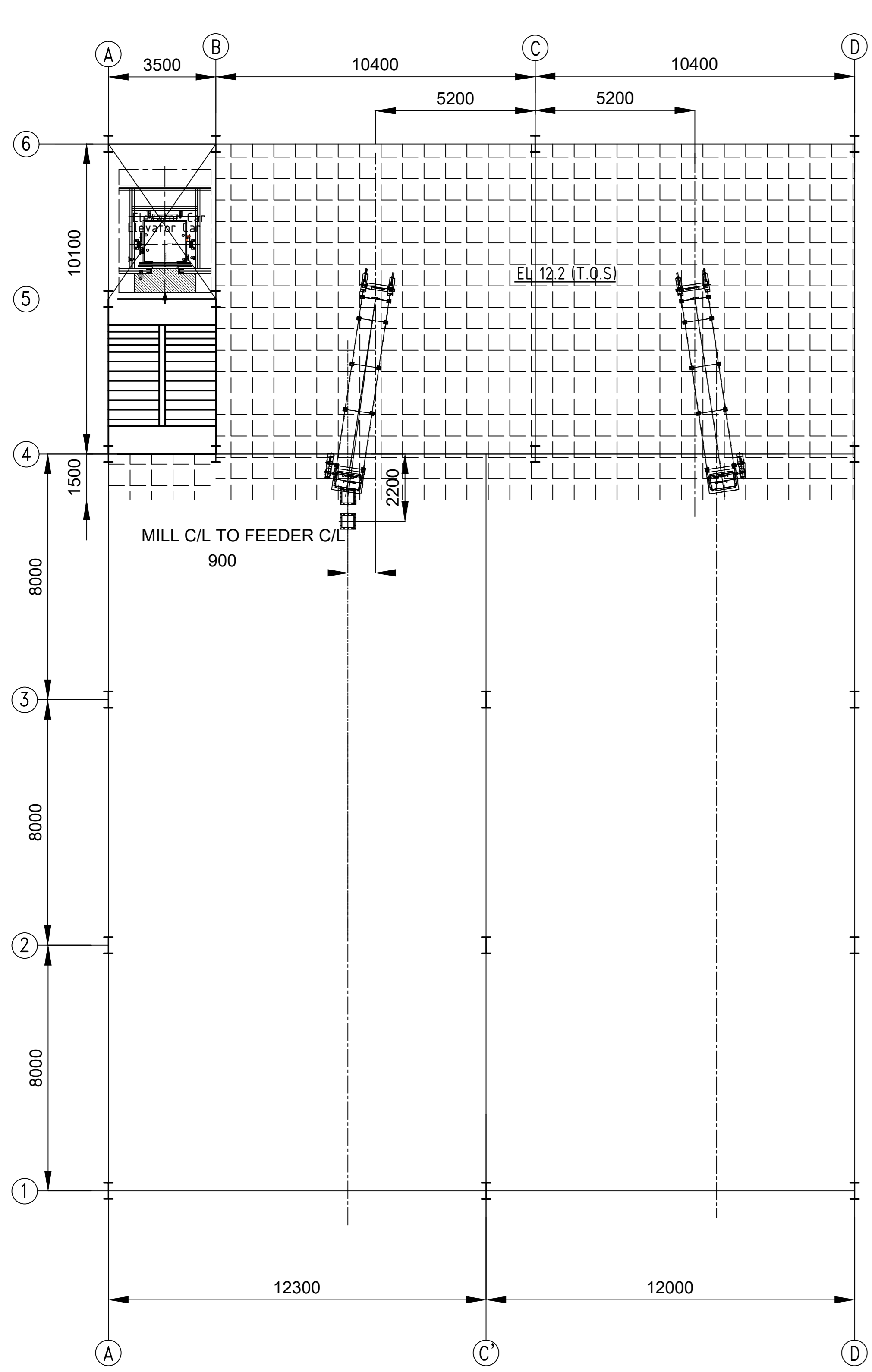

LOAD DATA IN KGS(PER SUPPORT)-

LOAD POINT	A1	A2	B1	B2	C1	C2	D1	D2	E1	E2
DEAD LOAD	600	600	600	600	600	600	600	600	600	600
LIVE LOAD	500	500	500	500	500	500	500	500	500	500

NOT TO EXCEED LOADS

- NOTES:-
- ALL DIMENSIONS ARE IN MM UNLESS ARE IN METERS.
 - RELIEF HOLES CORRESPONDING TO EL(+12.20M) F.F.L. IN THIS AREA IS EL(+1.00 M).
 - FLOOR OPENINGS SHALL BE CONSIDERED EXISTING UNLESS OTHERWISE SPECIFIED.
 - INSPECTION DOOR SHALL BE LEAK PROOF.
 - BUILDING HAS BEEN DESIGNED CONSIDERING ALL EQUIPMENTS, FEEDERS, BELT FEEDERS, CONVEYORS WORKING SIMULTANEOUSLY UNDER FULL LOAD.
 - GRAVIMETRIC FEEDER BELT DRIVE IS TENTATIVE ONLY AND SHALL BE FINALIZED AFTER GETTING SUPPLIER DATA.
 - BUILDING CLADDING SHALL BE AS PER TENDER.
 - CIVIL/STRUCTURAL DETAILS SHALL BE AS PER THE APPROVED CIVIL/ STRUCTURAL DRAWINGS.
 - INSPECTION DOOR SHALL BE LEAK PROOF.
 - CURB WALLS SHALL BE PROVIDED AROUND ALL OPENINGS & HANDRAILS AROUND ALL OPENING & CONCRETE EDGES.

- REFERENCE DRAWING:-
- PLANT PLAN OF PUD REF. DWG. 4200-109-001-HYD-PVM-B-010A
 - C.A. AND DATA SHEET OF BAG FILTER AT TOP OF LIMESTONE DAY SILO REFER DWG. 4200-109-001-HYD-PVM-Y-462
 - C.A. AND DATA SHEET OF WET BALL MILL REFER DWG. 4200-109-001-HYD-PVM-Y-463
 - C.A. AND DATA SHEET OF ELEVATOR (PASSENGER TYPE GOODIE ELEVATOR) OF DAY SILO REFER DWG. 4200-109-001-HYD-PVM-B-002
 - C.A. AND DATA SHEET OF AIR CATCHER OF LIMESTONE DAY SILO REFER DWG. 4200-109-001-HYD-PVM-B-003
 - SEWER EQUIPMENT DETAILS OF LIMESTONE BELT ELEVATOR- 4200-109-001-HYD-PVM-Y-458
 - C.A. AND DATA SHEET OF GRAVIMETRIC FEEDER REFER DWG. 4200-109-001-HYD-PVM-Y-456

LEGEND :-

F.F.L. = FINISHED FLOOR LEVEL
 P.A.L. = FINISHED GRAVEL LEVEL
 T.O.F.F. = TOP OF FINISHED FLOOR SLAB
 T.O.S. = TOP OF STEEL
 T.O.C. = TOP OF CONCRETE
 T.O.E. = TOP OF CONCRETE
 B.O.M.R. = BOTTOM OF MEMBER
 M.R. = MANUAL ROOST
 E.H. = ELECTRIC HOIST
 T.P. = TRANSFER POINT
 L.C. = LIMESTONE BELT CONVERTER
 C.S. = CENTRE RAMPING SPINNE
 L.S. = LIMESTONE STORAGE SILO

NTPC DRG NO: 4200-109-001-HYD-PVM-Y-462

KHALGAON STPP (4X210MW+3X300MW)
 PUD SYSTEM PACKAGE

REV	DATE	ALTD	CHKD	APPRD	BY	DATE
01	04.08.2022	ABUL KALAM	AMAN SURIN	KHRK	DRG	07.03.2022
					MD	07.03.2022
					APPD	07.03.2022

SHRABAT HEAVY ELECTRICALS LIMITED
 UNIT: HEAVY POWER EQUIPMENT PLANT
 RAMCHANDRAPURAM, HYDERABAD-500022

1. DRG IS REVISED AS PER NTPC COMMENTS VIDE TRANSMITTAL No- CC-ENG-4200-109-001-HYD-PVM-Y-462 DATED 09.05.2022

2. As per discussion with PEM-Civil & ISG

TITLE: GENERAL ARRANGEMENTS OF LIMESTONE DAY SILOS & WET BALL MILL BUILDING

DRAWING NO. 0-62-411-00037

SCALE: 1/10

SHEET 1 OF 2

REV 01

ANNEXURE-5

NTPC RAMAGUNDAM									
Painting Scheme : Wet Ball Milling system Outsourced (BOHT) Items									
Revision : 0 -- Date : 24.01.2022									
Outsourced (BOHT) Items									
Sl. No.	Description	Surface Preparation	Primer Coat	Intermediate Coat	Finished Coat	Total DFT - External surface	Colour shade for external surface	Remarks	
vi.	All Electrical & Instrumentation Items (applicable for slurry pumps)	Standard Bought out (BOHT) item. Color shade & DFT shall be maintained as per manufacturer standard							
4							Weigh Feeder		
i.	Weigh Feeder Assembly	Commercial blast Swedish Std. SA2.5	Two Coats of Epoxy resin based Epoxy Zinc Phosphate Primer to IS 13238. DFT- 50 µ/ Coat	One coat of two component epoxy based intermediate paint pigmented with Tio2. DFT- 100 µ	1) One coat of Epoxy based finish paint with glossy finish to IS 14209 DFT- 75µ 2) One coat of Acrylic aliphatic Polyurethane paint to IS 13213 DFT- 25µ	Total DFT min.300µm on External surfaces	RAL 9002 (Grey white)	The mention DFT shall be maintain on blasted surface only	

NTPC RAMAGUNDAM

Painting Scheme : Wet Ball Milling system Outsourced (BOHT) Items

Revision : 0 -- Date : 24.01.2022

Outsourced (BOHT) Items

Sl. No.	Description	Surface Preparation	Primer Coat	Intermediate Coat	Finished Coat	Total DFT - External surface	Colour shade for external surface	Remarks
ii.	Rod Gate	Commercial blast Swedish Std. SA2.5	Two Coats of Epoxy resin based Epoxy Zinc Phosphate Primer to IS 13238. DFT- 50 µ/ Coat	One coat of two component epoxy based intermediate paint pigmented with Tio2. DFT- 100 µ	1) One coat of Epoxy based finish paint with glossy finish to IS 14209 DFT- 75µ 2) One coat of Acrylic aliphatic Polyurethane paint to IS 13213 DFT- 25µ	Total DFT min.300µm on External surfaces	RAL 9002 (Grey white)	The mention DFT shall be maintain on blasted surface only
iii.	Connecting Chute	Commercial blast Swedish Std. SA2.5	Two Coats of Epoxy resin based Epoxy Zinc Phosphate Primer to IS 13238. DFT- 50 µ/ Coat	One coat of two component epoxy based intermediate paint pigmented with Tio2. DFT- 100 µ	1) One coat of Epoxy based finish paint with glossy finish to IS 14209 DFT- 75µ 2) One coat of Acrylic aliphatic Polyurethane paint to IS 13213 DFT- 25µ	Total DFT min.300µm on External surfaces	RAL 9002 (Grey white)	The mention DFT shall be maintain on blasted surface only

NTPC RAMAGUNDAM

Painting Scheme : Wet Ball Milling system Outsourced (BOHT) Items

Revision : 0 -- Date : 24.01.2022

Outsourced (BOHT) Items

Sl. No.	Description	Surface Preparation	Primer Coat	Intermediate Coat	Finished Coat	Total DFT - External surface	Colour shade for external surface	Remarks
iv.	Transition Chute	Commercial blast Swedish Std. SA2.5	Two Coats of Epoxy resin based Epoxy Zinc Phosphate Primer to IS 13238. DFT- 50 µ/ Coat	One coat of two component epoxy based intermediate paint pigmented with Tio2. DFT- 100 µ	1) One coat of Epoxy based finish paint with glossy finish to IS 14209 DFT- 75µ 2) One coat of Acrylic aliphatic Polyurethane paint to IS 13213 DFT- 25µ	Total DFT on External surfaces min.300µm	RAL 9002 (Grey white)	The mention DFT shall be maintain on blasted surface only
5	Pneumatic Diverter Gate							
i.	Distribution box & its BOHT/E & I componenets	Painting scheme, Color shade & DFT shall be maintained as per manufacturer standard.						
6	Motorized Slide Gate							
i.	Motorized Slide Gate	Standard Bought out (BOHT) item. Color shade & DFT shall be maintained as per manufacturer standard						
7	Agitator							
	Agitator	Standard Bought out (BOHT) item. Color shade & DFT shall be maintained as per manufacturer standard						

CLAUSE NO.	TECHNICAL REQUIREMENTS			
6.02.05	For dust free operation each silo should be provided with a covering arrangement and a self cleaning bag filter system of suitable capacity containing blower, automatic/on-load cleaning system, etc.			
6.02.06	For each silo facilities shall be provided for unloading the bunker, through feeder, to a truck at ground level, along with all necessary chutes and diversion chutes.			
6.02.07	Lime stone silo with hopper may be fabricated at factory in segments, transported and welded at site.			
6.03.00	Bunker Shut-off Gates			
6.03.01	A bunker outlet chute shall be provided for feeding limestone from bunker to the feeder. The size of the opening chute shall be sufficient to ensure proper flow of the limestone. There shall be no reduction of section in the bunker outlet chute from bunker to feeder. The inlet chute shall be provided with suitable poke doors/holes in order to remove jamming/blockage. A motorized bunker shut-off gate shall be provided at the inlet to each feeder.			
6.03.02	All parts of the gate in contact with limestone shall be of stainless steel construction.			
6.03.03	The shut-off gates and its actuator shall ensure 100% closing of the gate even with 'bunker full of limestone'.			
6.03.04	Facility shall be provided to open/close the bunker outlet gate, through actuator, from remote as well as local.			
6.03.05	In addition, a hand wheel with proper access shall also be provided for manual operation of the gate. The force at the rim of the hand wheel shall not exceed 35 kg with bunker full of limestone.			
6.03.06	For each bunker facilities shall be provided for unloading the bunker, through feeder, to a truck at ground level, along with all necessary chutes and diversion chutes.			
6.04.00	Gravimetric Feeders			
6.04.01	Gravimetric feeders shall be sized to meet 110% of the maximum mill capacity.			
6.04.02	The limestone feeder belt shall be of seamless rubber construction. It should be possible to adjust the belt tension from outside without opening the feeder body.			
6.04.03	All parts in contact with limestone except belt shall be of stainless steel construction.			
6.04.04	The feeder shall have adequate instrumentation to detect 'loss of flow'.			
6.04.05	The feeder shall have a motor/pneumatic operated gate at the outlet.			
6.05.00	Wet Ball Mill			
LOT-3 PROJECTS FLUE GAS DESULPHURISATION (FGD) SYSTEM PACKAGE		TECHNICAL SPECIFICATION SECTION-VI BID DOC. NO.:CS-0011-109(3)-9	PART-B SUB-SECTION-I-MI (FGD)	PAGE 22 OF 51

TECHNICAL SPECIFICATION OF MOTORS

GENERAL REQUIREMENTS

- For the purpose of design of equipment/systems, an ambient temperature of 50 deg. Centigrade and relative humidity of 95% (at 40 deg C) shall be considered. The equipment shall operate in a highly polluted environment.
- All equipment shall be suitable for rated frequency of 50 Hz with a variation of +3% & -5%, and 10% combined variation of voltage and frequency unless specifically brought out in the specification.
- Contractor shall provide fully compatible electrical system, equipment, accessories and services.
- All the equipment, material and systems shall, in general, conform to the latest edition of relevant National and international Codes & Standards, especially the Indian Statutory Regulations.
- Paint shade shall be as per RAL 5012 (Blue) for indoor and outdoor equipment.
- The responsibility of coordination with electrical agencies and obtaining all necessary clearances for contractors equipment and systems shall be under the contractor scope.

Degree of Protection

Degree of protection for various enclosures as per IEC60034-05 shall be as follows:-

- i) Indoor motors - IP 54
- ii) Outdoor motors - IP 55
- iii) Cable box-indoor area - IP 54
- iv) Cable box-Outdoor area - IP 55

CODES AND STANDARDS

- 1) Three phase induction motors : IS/IEC:60034
- 2) Single phase AC motors : IS/IEC:60034
- 3) Crane duty motors : IS:3177, IS/IEC:60034
- 4) DC motors/generators : IS/IEC:60034
- 5) Energy Efficient motors : IS 12615, IEC: 60034-30

TYPE

AC Motors:

- a) Squirrel cage induction motor suitable for direct-on-line starting.
- b) Continuous duty LT motors upto 200 KW Output rating (at 50 deg.C ambient temperature), shall be Premium Efficiency class-IE3, conforming to IS 12615, or IEC:60034-30. HT motors shall have minimum design efficiency of 95 % Tolerance on efficiency value applicable as per IEC 60034.
- c) Crane duty motors shall be squirrel cage Induction motor as per the requirement.
- d) Motor operating through variable frequency drives shall be suitable for inverter duty with VPI insulation. Also these motors shall comply the requirements stipulated in IEC: 60034-18-41 and IEC: 60034-18-42 as applicable.
- e) Motors operating through variable frequency drives shall also meet the requirements mentioned in subsection for VFD.

RATING

- (a) Continuously rated (S1). However, crane motors shall be rated for S4 duty, 40% cyclic duration factor.
- (b) Whenever the basis for motor or driven equipment ratings are not specified in the corresponding mechanical specification sub-sections, maximum continuous motor ratings shall be at least 10% above the maximum load demand of the driven equipment under entire operating range including voltage and frequency variations.

TEMPERATURE RISE

Air cooled motors

70 deg. C by resistance method for both thermal class 130(B) & 155(F) insulation.

Water cooled

80 deg. C over inlet cooling water temperature mentioned elsewhere, by resistance method for both thermal class 130(B) & 155(F) insulation. 41 deg.C over inlet cooling water maximum temperature of 39 deg.C for thermal class 90 (Y) wet wound Boiler circulation pump motor.

OPERATIONAL REQUIREMENTS

Starting Time

For motors with starting time upto 20 secs at minimum permissible voltage during starting, the locked rotor withstand time under hot condition at highest voltage limit shall be at least 2.5 sec more than starting time.

For motors with starting time more than 20 secs and upto 45 secs at minimum permissible voltage during starting, the locked rotor withstand time under hot condition at highest voltage limit shall be at least 5 secs. more than starting time.

For motors with starting time more than 45 secs. at minimum permissible voltage during starting, the locked rotor withstand time under hot condition at highest voltage limit shall be more than starting time by at least 10% of the starting time.

Speed switches mounted on the motor shaft shall be provided in cases where above requirements are not met.

Torque Requirements

Accelerating torque at any speed with the lowest permissible starting voltage shall be at least 10% motor full load torque.

Pull out torque at rated voltage shall not be less than 205% of full load torque. It shall be 275% for crane duty motors.

Starting voltage requirement

- (a) Up to 85% of rated voltage for ratings below 110 KW
- (b) Up to 80% of rated voltage for ratings from 110 KW to 200 KW
- (c) Up to 85% of rated voltage for ratings from 201 KW to 1000 KW
- (d) Up to 80% of rated voltage for ratings from 1001 KW to 4000 KW
- (e) Up to 75 % of rated voltage for ratings above 4000KW

Except AOP & JOP motors running on D.G emergency supply, starting voltage shall be 80%.

DESIGN AND CONSTRUCTIONAL FEATURES

Suitable single phase space heaters shall be provided on motors rated 30KW and above to maintain windings in dry condition when motor is standstill. Separate terminal box for space heaters & RTDs shall be provided. However for flame proof motors, space heater terminals inside the main terminal box may be acceptable.

All motors shall be either Totally enclosed fan cooled (TEFC) or totally enclosed tube ventilated (TETV) or Closed air circuit air cooled (CACA) type. However, motors rated 3000KW or above can be Closed air circuit water cooled (CACW). The method of movement of primary and secondary coolant shall be self-circulated by fan or pump directly mounted on the rotor of the main motor as per IEC 60034-6. However VFD driven motors can be offered with forced cooling type with machine mounted fan or pump driven by separate electric motor. Motors and EPB located in hazardous areas shall have flame proof enclosures conforming to IS: 2148 as detailed below

(a) Fuel oil area: Group – IIB

(b) Hydrogen generation: Group - IIC or (Group-I, Div-II as per plant area NEC) or (Class-1, Group-B, Div-II as per NEMA / IEC60034)

Winding and Insulation

(a) Type: Non-hygroscopic, oil resistant, flame resistant

(b) Starting duty: Two hot starts in succession, with motor initially at normal running temperature.

(C) 240VAC, 415V AC & 220V DC motors: Thermal Class (B) or better

Motors with heat exchangers shall have dial type thermometer with adjustable alarm contacts to indicate inlet and outlet primary air temperature.

Noise level for all the motors shall be limited to 85dB (A). Vibration shall be limited within the limits prescribed in IS/IEC 60034-14. Motors shall withstand vibrations produced by driven equipment. HT motor bearing housings shall have flat surfaces, in both X and Y directions, suitable for mounting 80mmX80mm vibration pads.

Motor body shall have two earthing points on opposite sides.

The spacing between gland plate & center of bottom terminal stud shall be as per Table-I.

All motors shall be so designed that maximum inrush currents and locked rotor and pullout torque developed by them at extreme voltage and frequency variations do not endanger the motor and driven equipment.

The motors shall be suitable for bus transfer schemes provided on the 11kV, 3.3 Kv /415V systems without any injurious effect on its life.

The size and number of cables (for HT and LT motors) to be intimated to the successful bidder during detailed engineering and the contractor shall provide terminal box suitable for the same.

The ratio of locked rotor KVA at rated voltage to rated KW shall not exceed the following (without any further tolerance).

- (a) From 50KW & upto 110KW : 11.0
- (b) From 110 KW & upto 200 KW : 9.0
- (c) Above 200 KW & upto 1000KW : 10.0
- (d) From 1001KW & upto 4000KW : 9.0
- (e) Above 4000KW : 6 to 6.5

TYPE TEST

LT Motors supplied shall be of type tested design. During detailed engineering, the contractor shall submit for employer's approval the reports of all the type tests as listed in this specification and carried out within last *ten* years from the date of bid opening. These reports should be for the test conducted on the equipment similar to those proposed to be supplied under this contract and the test(s) should have been either conducted at an independent laboratory or should have been witnessed by a client.

However if the contractor is not able to submit report of the type test(s) conducted within last ten years from the date of bid opening, or in the case of type test report(s) are not found to be meeting the specification requirements, the contractor shall conduct all such tests under this

contract at no additional cost to the employer either at third party lab or in presence of client/ employer's representative and submit the reports for approval.

LIST OF TESTS FOR WHICH REPORTS HAVE TO BE SUBMITTED

The following type test reports shall be submitted for each type and rating of LT motor of above 100 KW only

1. Measurement of resistance of windings of stator and wound rotor.
2. No load test at rated voltage to determine input current power and speed
3. Open circuit voltage ratio of wound rotor motors (in case of Slip ring motors)
4. Full load test to determine efficiency power factor and slip.
5. Temperature rise test.
6. Momentary excess torque test.
7. High voltage test.
8. Test for vibration severity of motor.
9. Test for noise levels of motor (Shall be limited to 85dB (A)).
10. Test for degree of protection and
11. Over speed test.
12. Type test reports for motors located in fuel oil area having flame proof enclosures as per IS 2148 / IEC 60079-1

All acceptance and routine tests as per the specification and relevant standards shall be carried out. Charges for these shall be deemed to be included in the equipment price.

The type test reports once approved for any projects shall be treated as reference.

For subsequent projects of NTPC, an endorsement sheet will be furnished by the manufacturer confirming similarity and "No design Change". Minor changes if any shall be highlighted on the endorsement sheet.

TABLE - I
DIMENSIONS OF TERMINAL BOXES FOR LV MOTORS

Motor MCR in KW

**Minimum distance between centre of
bottom terminal stud and gland plate in mm**

UP to 3 KW

As per manufacturer's practice.

Above 3 KW - upto 7 KW	85
Above 7 KW - upto 13 KW	115
Above 13 KW - upto 24 KW	167
Above 24 KW - upto 37 KW	196
Above 37 KW - upto 55 KW	249
Above 55 KW - upto 90 KW	277
Above 90 KW - upto 125 KW	331
Above 125 KW-upto 200 KW	385/203 (For Single core cables only)

PHASE TO PHASE/ PHASE TO EARTH AIR CLEARANCE:

NOTE: Minimum inter-phase and phase-earth air clearances for LT motors with lugs installed shall be as follows:

Motor MCR in KW

Clearance

UP to 110 KW	10mm
Above 110 KW and upto 150 KW	12.5mm
Above 150 KW	19mm

LT MOTOR APPROVED VENDORS ARE GIVEN BELOW. HT MOTORS TO BE SOURCED FROM SHEL/ABB/SIEMENS

04	LT MOTORS	a) KEC	Bangalore/ Hubli (Up to 90KW)	Please refer remark column for Categorization	BAP/QR/ G501 & G502/LTM:012 Rev NO: 00 dt 17 05 2018	Cat I Above 50 KW and up to 200KW NTPC inspn as per appd RQP/MQP	
		c) CGL	Ahmednagar	Please refer remark column for Categorization			
		b) SIEMENS	Mumbai	Please refer remark column for Categorization	** Acceptance of Motor rating between 30KW to 50 KW is based on NTPC Review of Routine Test Inspection report as per IS 325 Witnessed by BHEL/BHEL AIA ie Main contractor along with COC of the manufacturer and the contractor confirming as follows: "It is hereby confirmed that the above mentioned motor was /motors were manufactured taking care of NTPC specific requirements regarding ambient temperature, voltage and frequency variation, hot starts , pull out torque, starting KVA/KW, temperature rise, distance between centre of stud and gland plate, space heater and in accordance with approved drawing /data sheets"	Cat-II **From 30KW to 50KW BHEL Inspection	
		c)ABB	Faridabad up to 55KW/ Bangalore above 55KW				
		a) BBL	Mumbai	##Acceptance of Motor less than 30KW is based on COC of the manufacturer and the contractor conforming as follows: "It is here by confirmed that the above mentioned motor/motor was / were manufactured taking care of NTPC specific requirements regarding ambient temperature, voltage and frequency variation, hot starts , pull out torque, starting KVA/KW, temperature rise ,distance between centre of stud and gland plate and tested m accordance with approved drawing /data sheet".		# #Cat-III Up to 30KW	
		b) NGEF	Hubli (up to15KW)				
		c) Marathon	Kolkata				
		d) Jyoti	Vadodara				
		e) LHP	Solapur				
		(For other PMD vendors except above NTPC approved vendors, pl refer Sino. 4 under important notes in page no: 11)					

Prepared by: C(.
(Ch.Anil Singh)
Dy. Engineer/QA (Electrics)

Reviewed by: *g.H-*
(S.Sheela)
Dy.Manager/QA (Electrics) & System

Approved by: *4: T. [Signature]*
(K. iParimalam)
DGM / QA (Electrics)

TECHNICAL SPECIFICATION OF VARIABLE FREQUENCY DRIVES**GENERAL**

The Design, manufacture, erection, testing and performance of items and services provided under this specification shall comply with the latest edition including all applicable official amendments and revisions as on date of award of the following standards. In case of conflict between this specification and code (IS Code, standards, etc.) referred herein, the former shall prevail. All work shall be carried out as per the following codes and standards.

CODES AND STANDARDS

HT breaker	IEC:60056
DC reactor	IEC 60289
Transformers	IS:2026, IEC: 60076 IEC 61378
Bushing	IS: 2099, IEC 60137
Adjustable Speed Electrical Power Drive Systems	IEC 61800
Semiconductor converters–General requirements	IEC 60146
IEEE Recommended practices and requirements for harmonic control in electrical power systems	IEEE 519
Degrees of protection provided by enclosures (IP Code)	IEC 60529
Electrostatic immunity test	IEC1000-4-2
Fast transient immunity test	IEC1000-4-4
Surge immunity test	IEC1000-4-5
High-voltage switchgear and control gear; Pt.102: Alternating current disconnectors and earthing switches	IEC 62271-102
High-voltage switchgear and control gear; Pt.200: AC metal-enclosed switchgear and control gear for rated voltages above 1 kV and up to and including 52 KV	IS/IEC: 62271-200
AC electricity meters	IS: 722
Metal oxide surge arrester without gap for AC system	IEC: 60099-4
Terminal blocks for copper conductors	IEC: 60947-7-1
Dry transformer	IS: 11171
Motor	IEC 60034-18-41 &42, IEC60034 / NEMA 30 &31,
Contactor/Switches/Fuses etc.	IEC:60947, IS: 13947
Harmonics & EM compatibility	IEEE:519/IEC: 61000
VFD	IEC: 60034/ IEC: 61800

Equipment complying with other internationally accepted standards will also be considered if they ensure performance and constructional features equivalent or superior to standards listed above. In such a case, the Bidder shall clearly indicate the standard(s) adopted, furnish a copy in English of the latest revision amendments and revision in force as on date of opening of bid and shall clearly bring out the salient features for comparison.

OPERATING CONDITIONS

For the purpose of design of equipment/systems, an ambient temperature of 50 deg. Centigrade and also relative humidity of 95% at 40 deg. Celsius shall be considered.

All equipment shall be suitable for rated frequency of 50 Hz with a variation of +3% & -5%, and 10% combined variation of voltage and frequency unless specifically brought out in the specification.

The auxiliary AC voltage supply arrangement shall have 11/6.6/3.3kV and 415V systems (as applicable). It shall be designed to limit voltage variations as given below under worst operating condition: 415V : +/- 10%

Note: The Voltage level mentioned above is the Nominal Voltage available at the input of the VFD System from the MCC/ Switchgear/transformer, based on the system requirement/Availability.

The voltage level for the VFD output to be fed to motor shall be as follows:- Upto 400 kW : 415V/690V, Low Voltage, Three Phase AC

From here onwards in the specifications all the VFD Systems consisting of either 415 V or 690 V may be termed as LV VFD while the higher rated VFD System shall be termed as MV VFD. If nothing is mentioned than the Clause is applicable for both the LV and the MV VFD until deliberated otherwise.

SYSTEM DESCRIPTION

Type of drive	3-Phase Diode / Thyristor / Multi Stage IGBT / IGCT / SGCT/ IEGT.
Type of Cooling of VFD	Naturally air cooled/forced air cooled/Liquid cooled.
Converter Type	Full wave diode rectifier/active front end type.
Inverter Type	Thyristor/IGBT/IGCT/SGCT/IEGT.

GENERAL REQUIREMENTS

415 V/690 V LV VFD: The Variable frequency drive (VFD) system shall be of a modern proven design for similar applications in power plants/industry. The system shall be either Current Source Inverter (CSI) or Voltage Source Inverter (VSI) type with minimum Twelve (12) pulse design. For drives less than 100 KW Six (6) pulse can be offered meeting all other requirements.

The system shall be fully digital, PLC/Microprocessor based, energy efficient, and shall provide very high reliability, high power factor, low harmonic distortion and low vibration and wear and noise. It shall be easy to install in minimum time and expense and no special tools shall be required for routine maintenance.

The offered equipment shall be with state of art technology and proven field track record. No prototype equipment shall be offered.

The VFD manufacturer shall ensure the proper coordination of their VFD with the Driven Motor and the supply system. All the Motors which are to be driven by VFDs will be of Inverter duty type. The VFD operation shall have no inherent detrimental impact on the Motors/ cables & supply system.

TECHNICAL AND OPERATIONAL REQUIREMENTS

The system shall be designed to deliver the motor input current and torque for the complete speed torque characteristics of the driven equipment, with worst input supply voltage and frequency variation. The system shall be suitable for the load characteristics and the operational duty of the driven equipment.

The overload capacity of the controller shall be 150% of the rated current of the motor for one minute for constant torque applications and 110% of rated current for one minute for variable torque applications at rated voltage. If the motor load exceeds the limit, the drive shall automatically reduce the frequency and voltage to the motor to guard against overload.

The drive system shall be designed to operate in one or more of the following operating modes as to suit characteristics of the driven equipment or specified by the load:

- a. Variable torque changing as a function of speed.
- b. Constant torque over a specific speed range.
- c. Constant power over a specific speed range.
- d. Any other as specified in data-sheet

VFDs shall comply with the latest edition of IEEE 519 & IEC 61000 for both individual as well as total harmonic voltage and current distortion limits. The Voltage and Current limits shall be applicable at the Point of Common Coupling (PCC), which shall be the MCC/ Switchgear/ from which the VFD system is fed.

The above compliance shall be verified by the field measurements of harmonics at the PCC with and without VFDs operation.

VFD shall be capable of withstanding the thermal and dynamic stresses and the transient mechanical torque, resulting from short circuit. Any damage resulting from such a short circuit or internal fault shall be limited to the component concerned.

The system shall be suitable to maintain speed variation within range 10-110% or as per the requirement of driven equipment with speed set accuracy of +1% of rated maximum speed and steady state regulation of +0.5% of rated speed as per system requirement.

The VFD System shall maintain a power factor of 0.95 (minimum) (for LV VFD system) and 0.9 (minimum) (for MV VFD system) in the entire operating range.

Maximum allowable audible noise from the VFD system will be 85 dB (A) at a distance of one meter under rated loaded with all cooling fan operating conditions.

All the circuit components shall be suitably protected against over voltages, surges, lightning etc.

The panels shall be designed to provide easy access to hardware, to facilitate replacement of cards in case of any failure.

All the VFDs for particular application shall be of same design so as to ensure 100 % inter-changeability of components.

For each programmed warning and fault protection function, the VFD shall display a message in complete English words or Standard English abbreviations. At least 30 time tagged fault messages shall be stored in the drive's fault history.

The VFD cubicles shall be placed in air conditioned environment. However if VFDs of less than 100 kW are designed to operate in non-air condition environment the same shall also be acceptable.

The 3-Phase Thyristor/IGCT/SGCT/ multistage IGBT/IEGT based VFD system shall have minimum number of components to ensure very high reliability. The input side converter shall have 3-Phase Diode/Thyristor bridge configuration modular type and inverter shall be of 3-Phase Thyristor/IGCT/SGCT/multi stage IGBT/IEGT type, using Pulse Width Modulation or better technique for generating near sine wave output to motor.

Fiber optic cable connection shall be provided preferably to ensure high network Reliability.

VFD COMPATIBILITY WITH THE MOTOR

MV VFD output current waveform, as measured at the motor, shall be inherently sinusoidal at nominal loads, with a total harmonic current and voltage distortion within acceptable/standard limits. VFD with transformers on output side are not acceptable.

The system design shall not have any inherent output harmonic resonance in the operating speed range.

VFD shall provide stable operation of motor from high-voltage dv/dt stress, regardless of cable length to motor. The vendor shall clearly state the limitations in the motor cable distance in his proposal. However, due to system requirements & constraints if the cable length becomes critical, filters/ chokes etc. shall be provided by the VFD manufacturers as an integral part of the VFD to mitigate the reflected wave effect of harmonics.

BYPASS ARRANGEMENT (OPTIONAL, IF SPECIFIED)

The VFD System shall have an optional feature to run the motor under bypass arrangement for operation of Motor with VFD bypassed. During starting (under rated conditions) the motor will be switched on in VFD Mode to limit the starting current and after gaining speed, the load would be switched over to bypass mode.

Comprehensive motor protection scheme for protection and control for operation VFD during bypass mode shall be finalized during detailed engineering.

STANDBY VFD ARRANGEMENT (OPTIONAL, IF SPECIFIED)

A Common standby arrangement with auto/manual switchover shall be provided in case of failure of any VFD in a group of drives. Complete protection, interlocks & control required shall be provided in the changeover module.

EFFICIENCY

Efficiency (Drive only) shall be minimum 98% for both MV VFD and LV VFD. Overall efficiency shall be minimum 96.5% for LV VFD and minimum 94 % for MV VFD at rated load and speed. Overall Efficiency evaluation shall include input transformer, harmonic filters and power factor correction (if applicable), VFD converters, cooling fans and output filter, as applicable in the system. Auxiliary controls, such as internal VFD control boards, cooling fans/pumps.

In absence of valid test report, a factory test shall be performed at the VFD manufacturer's facility verifying the efficiencies. Manufactures who are supplying Drive and transformer from different locations, efficiency test will be conducted separately for Drive and transformer.

COOLING SYSTEM

The VFD shall be designed to operate indoor under temperature range of 0 deg C to 50 deg C and relative humidity of 95 %(at 40 deg C).

VFD manufacturer to primarily offer Air cooled Design. However in case of large ratings, liquid cooled drives may be accepted subject to employer's approval. In case of liquid cooled system, there shall be no necessity of continuous water supply system (Closed Loop System).

In case of Air cooled design, the VFD Cooling system shall be such that it puts minimum heat load inside the room and preferably throw the hot air outside the room with ventilation ducts. The Cooling system shall be designed in such a way that the Air Conditioning & Ventilation Air requirements are kept to minimum. The VFD Manufacturer shall furnish the data regarding heat load, air flow requirements during the detailed engineering.

Air cooled VFDs shall be provided with cooling fans mounted integral to the VFD/ enclosure. The VFD shall include air-flow pressure switches and temperature detectors to monitor proper operation of the air cooling system. If the fan fails, the system must generate the alarm/trip for the fan failure.

TRANSFORMER:

Type: Outdoor Mineral oil filled ONAN type or Indoor natural air-cooled Dry type, Three phase unit, rectifier/converter duty type transformer.

All other components, technical parameters shall be as per applicable IEC/IS.

Enclosure for Dry Type Transformer (as applicable)

Enclosure shall be of a tested quality sheet steel of minimum thickness 2 mm & shall also accommodate cable terminations. The housing door shall be interlocked such that it should be possible to open the door only when transformer is off. The enclosure shall be provided with lifting lugs and other hardware for floor mounting.

Core shall be High grade non-ageing cold rolled grain oriented silicon steel Laminations.

Winding conductor shall be electrolytic grade copper.

Windings shall be of class F insulation.

Winding temperature shall be Platinum resistance type temperature Indicator (WTI) detector in each limb.

Thermistors shall be embedded in each limb with alarm and trip contacts for remote annunciation.

Temperature rise: Winding temperature rise shall be as per applicable IEC.

POWER CONVERTER:

The static power converter shall consist of a line side converter for operation as a rectifier and a load side power converter for operation as a fully controller inverter. Power converter shall be fast switching, most efficient and low loss type.

The converter shall be coordinated with the transformers. The converter shall be able to withstand a three phase short circuit current until interrupted by normal breaker operation.

Adequate short circuit and over voltage protection shall be provided for the converter and inverter system.

All power converter devices shall include protective devices, snubber networks and dv/dt networks as required.

The current rating of the converter's semi-conductor components shall not be less than 120% of the nominal current flowing through the elements at full load of the VFD through the whole speed range. If the parallel connection of semiconductor is applied, the above current rating shall not be less than 140% of the above values.

All power diodes shall be of silicon type with minimum VBO rating at 2.5 times the rated operating voltage.

The power converter circuit shall be designed so that motor can be powered at its full nameplate rating continuously without exceeding its rated temperature rise nor reducing its service factor due to harmonic currents generated by the inverter operation. The conversion devices and associated heat sinks shall be assembled such that individual devices can be replaced without requiring the use of any special precautions / tools.

The cooling system of the electronic components, if provided, shall be monitored and necessary alarms shall be provided to prevent any consequential damage to the power control devices.

OUTPUT FILTER (AS APPLICABLE):

Output/ dv/dt filter shall be provided, if required. It shall be an integral part of the VFD system and included within the VFD enclosure. It shall inherently protect motor from high voltage dv/dt stress.

DC LINK CAPACITOR (AS APPLICABLE):

Capacitor shall be of self-healing film or electrolytic type having high life time. The capacitor shall be an integral part of VFD system. DC link Capacitors shall have discharge resistors which shall be capable of reducing the residual charges to zero just after the capacitor is disconnected from the supply source. The capacitor shall be suitable for high ripple currents.

DC Reactor (As applicable)

- 1) Type: Dry type, air cored, self-cooled, indoor type. Suitable for withstanding earth fault continuously.
- 2) Insulation: Thermal Class 155(F), temperature rise is limited to thermal class 130 (B).
- 3) Noise level shall not exceed value specified in NEMA TR-1.

VFD PANEL REQUIREMENTS

Enclosure frames and load bearing members shall be fabricated using suitable mild steel structural sections or pressed and shaped cold-rolled sheet steel of thickness 2.0 mm. Frames shall be enclosed in cold-rolled sheet steel of thickness 1.6 mm. Doors and covers shall also be of cold rolled sheet steel of thickness 1.6 mm. Stiffeners shall be provided wherever necessary. The gland plate thickness shall be 3.0 mm for hot / cold-rolled sheet steel and 4.0 mm for non-magnetic material. In case dry type transformer is provided inside VFD panels, the enclosure and in its frame thickness shall be same as indicated in this para.

The cable entry shall be from the bottom of the panel and a removable bolted undrilled gland plate.

All Panels shall be of dust-proof and vermin-proof construction and shall be provided with a degree of protection of IP: 4X as per IS/IEC 60947.

Enclosures must be designed to avoid harmonic and inductive heating effects and to shield any outside equipment from interference, enclosing and shielding the complete to eliminate any radio frequency interference. The construction of the panel shall provide effective protection against electromagnetic emissions.

Each panel shall be provided with illuminating lamp, space heater with switch fuse and variable setting thermostat.

Proper ventilation using air filters and fans/pumps shall be provided in the panels to ensure that maximum temperature inside the cubicle is within permissible limits for reliable and continuous operation of the system.

PAINTING

Paint shade shall be as follows

- a) VFD transformer reactor enclosure : RAL 5012 (Blue), legend in black letter
- b) Motors : RAL 5012 (Blue)
- c) VFD Panels : Front and rear panels in Grey (RAL9002). End panel sides in blue (RAL 5012)

MOTORS

VFD shall be used to drive three (3) phase squirrel cage inverter duty Induction motor with VPI insulation (Resin poor) suitable for VFD application. These motors shall be provided with insulated bearing on at least one side.

Motors shall also meet the requirements mentioned in subsection for motors and relevant IS/IEC.

Motor shall be suitable for operation with a solid state power supply consisting of an adjustable frequency inverter for speed control & shall be suitable for the current waveforms produced by the power supply including the harmonics generated by the drive.

Motor insulation shall be designed to accept the applied voltage waveform, within the V_{peak} and dv/dt limits as per IEC-61800.

Drive manufacturer shall coordinate with the motor manufacturer for proper selection of the motor for the given load application and the output characteristics of the drive.

Other requirements of motor shall be as stipulated in technical chapter of Motors in technical specifications.

CONTROL AND PERFORMANCE REQUIREMENTS

The VFD to provide an automatic current limiting feature to control motor currents during startup and provide a “soft start” torque profile for the motor load combination. Current and torque limit adjustments shall be provided to limit the maximum VFD output current and the maximum torque produced by the motor.

It shall be possible to vary the speed of the drive and control it in either Local or Remote mode. Local / Remote selection shall be done from VFD panel unless otherwise specified.

Provision shall be kept for exchange of information between different VFD control system parameters thru PLC/DDCMIS.

Man machine interface for (MV) VFD shall have one flat TFT monitor with keyboard (password protected) in the VFD room and a color laser printer for system alarm and monitoring located in control room.

Parameter Monitoring:

- Input and output voltage of Drive
- Input and output current of Drive
- Motor speed
- Input and output power frequency of Drive
- Torque
- Input and Output power of Drive system (covering transformer if applicable)
- Output kWhr of Drive
- Transformer (if applicable) temperature for alarm & trip.
- Ambient temperature
- Run/stop and local/remote status displayed

Drive shall be equipped with a front mounted operator console panel consisting of a backlit alphanumeric display and a keypad with keys for parameterization and adjusting parameter. Control panel shall be operable with password for changing the protection setting, safety interlock etc.

Operator console/Main Control Card shall have facility / port to connect external hardware such as Lap-Top etc. Console shall have facility for upload and download of all parameter settings from one drive to another drive for start-up and operation.

User-friendly licensed software for operation and fault diagnostic shall be loaded in the drive system panel before commissioning.

PROTECTION FEATURES

The system offered shall incorporate adequate protection features as per IEC 61800- 4: 2002 Table-8, properly coordinated for the drive control and for motor including following:

- i) Converter transformer: short circuit, over current, earth fault & winding temperature high protection.
- ii) Incoming and outgoing line surge protection.
- iii) Under / over voltage protection
- iv) Phase loss, phase reversal, overload, negative phase sequence, locked rotor protection.
- v) Instantaneous Over current & Earth fault protection
- vi) Converter/Inverter module failure indication.
- vii) Over frequency/speed protection.
- viii) Ventilation failure indication & alarm.
- ix) Over temperature of VFD
- x) Bearing temperature protection.
- xi) System earth fault protection.
- xii) Speed reference loss protection.

Under VFD Bypass Mode (if applicable) all the electrical protections related to the Motor shall remain applicable.

CONTROL FEATURES

Following controls shall be provided as a part of the Operator Control Panel or through separate switches on the front panel door.

- i) Start / stop (in local/remote mode)
- ii) Speed control (Raise / lower)
- iii) Acknowledge/Accept/ Test Push Button for annunciation
- iv) Auto / Manual / Test Mode select
- v) Emergency stop
- vi) Trip-Remote Breaker

DIAGNOSTIC FEATURES

The VFD shall include a microprocessor/PLC based digital diagnostic system which monitors its own control functions and displays faults and operating conditions.

Fault diagnostic shall be built into the system to supervise the operation and failure of the system. The information regarding failure of any of the system including shut down of the system shall be available. It shall be possible to retrieve the record of events prior to tripping of the system or de-energization. Auxiliary supply to the system components or to the electronics (firmware) for the diagnostics / display shall be taken care of by the manufacturer for this purpose.

SERVICEABILITY / MAINTAINABILITY

Front Access: VFD system should be designed for front access only. Manufacturer shall state in his proposal if rear access is provided.

Power Component Accessibility: All power components in the converter sections shall be designed for rack-out accessibility for ease of maintenance and to minimize repair downtime.

Marking / Labeling: Sleeve type wire marker tags or other acceptable means of permanent identification shall be applied to power and control wiring. Individual labels shall be provided for all major components of the VFD system.

STORAGE AND PRESERVATION

The Contractor shall be responsible for the storage and preservation of all the equipments to be supplied under the VFD System, till the time of successful installation and commissioning. The equipment should be suitable for storage for long periods before installation. Contractor should take adequate measures to ensure that no damage happens to the VFD System due to storage and preservation.

TESTS

ROUTINE TESTS

All acceptance and routine tests as envisaged in QA section shall be carried out. Charges for these shall be deemed to be included in the equipment price.

TYPE TESTS

The Contractor shall carry out the type tests as listed in this specification on the equipment to be supplied under this contract. The bidder shall indicate the charges for each of these type tests separately in the relevant schedule and the same shall be considered for the evaluation of the bids. The type tests charges shall be paid only for the test(s) actually conducted successfully under this contract and upon certification by the employer's engineer.

The type tests shall be carried out in presence of the employer's representative, for which minimum 15 days' notice shall be given by the Contractor. The Contractor shall obtain the employer's approval for the type test procedure before conducting the type test. The type test procedure shall clearly specify the test set-up, instruments to be used, procedure, acceptance norms, recording of different parameters, interval of recording, precautions to be taken etc. for the type test(s) to be carried out.

In case the Contractor has conducted such specified type test(s) within last ten years as on the date of bid opening, he may submit during detailed engineering the type test reports to the Employer for waiver of conductance of such test(s). These reports should be for the tests conducted on the equipment similar to those proposed to be supplied under this contract and test(s) should have been either conducted at an independent laboratory or should have been witnessed by a client. The Employer reserves the right to waive conducting of any or all the specified type test(s) under this contract. In case type tests are waived, the type test charges shall not be payable to the Contractor.

Further the Contractor shall only submit the reports of the type tests as listed in "LIST OF TESTS FOR WHICH REPORTS HAVE TO BE SUBMITTED" and carried out within last ten years from the date of bid opening. These reports should be for the test conducted on the equipment similar to those proposed to be supplied under this contract and the test(s) should have been either conducted at an independent laboratory or should have been witnessed by a client. However if the Contractor is not able to submit report of the type test(s) conducted within last ten years from the date of bid opening, or in the case of type test report(s) are not found to be meeting the specification requirements, the Contractor shall conduct all such tests under this contract at no additional cost to the Employer either at third party lab or in presence of client/Employers representative and submit the reports for approval.

LIST OF TESTS FOR WHICH REPORTS HAVE TO BE SUBMITTED

The following type test reports shall be submitted for VFD Panels'

1) VFD panels (For LV VFD)

- i. Rated Current/ Output
- ii. Temperature rise test
- iii. Noise level test
- iv. Power Loss Determination Test
- v. Power factor measurement.
- vi. Degree of Protection Test
- vii. EMC Test
- viii. The Fast transient SWC tests as per ANSI / IEEE C37.901-2002 / IEC 60255-22-04-2008 / IEC 61800

2) AC/DC Reactor

- i. Lightning impulse test(If applicable)
- ii. Heat run test
- iii. Short time current test(If applicable)
- iv. Noise level tests

**INSTRUMENTATION CABLE, CONTROL & POWER SUPPLY CABLE,
INTERNAL WIRING AND ELECTRICAL FIELD CONSTRUCTION MATERIAL**

General requirements

- All cables including special cables, internal wiring and electrical field construction material shall conform to this specification, Employer approved detail engineering drawings & documents and the latest edition of the relevant standards & guidelines. The Bidder shall furnish all material and services required for the completeness of the work identified in his scope as per this specification.
- The Contractor shall supply, erect, terminate and test all instrumentation cables for control and instrumentation equipment/devices/systems included under Contractor's scope and ensuring completeness of the control system.
- Any other application where it is felt that instrumentation cables are required due to system/operating condition requirements, are also to be provided by Contractor.
- Other type of cables like fiber optic/co-axial cables for system bus, cables for connection of peripherals etc. (under Contractor's scope) are also to be furnished by the Contractor.
- Contractor shall supply all cable erection and laying hardware from the main trunk routes like branch cable trays/sub-trays, supports, flexible conduits, cable glands, lugs, pull boxes etc. on as required basis for all the systems covered under this specification.
- Wherever the quantity has been defined as on as required basis, the same are to be furnished by contractor on as required basis within his quoted lump sum price without any further cost implication to the Employer.

SPECIFICATION OF INSTRUMENTATION CABLE

Common Requirements

S. No.	Property	Requirement
1	Operating Voltage	225 V (peak value)
2.	Codes and standard	All instrumentation cables shall comply with VDE 0815, VDE 0207, Part 4, Part 5, Part 6, VDE 0816, VDE 0472, SEN 4241475, ANSI MC 96.1, IS-8784, IS-10810 (latest editions) and their amendments read along with this specification.
3.	Continuous operation suitability	At 205 Deg C for Type-C cables & heat resistant cables, at 70 Deg C for all other type of cables.
4.	Marking :-	<p>a. <i>Progressive automatic on-line sequential marking of length in meters to be provided at every one meter on outer sheath.</i></p> <p>b. Marking to read 'FRLS' to be provided at every 5 meters on outer sheath except for Type-C cable</p> <p>c. Durable marking at intervals not exceeding 625 mm shall include manufacturer's name, insulation material, conductor's size, number of pairs, voltage rating, type of cable, year of manufacturer to be provided on outer sheath.</p>

S. No.	Property	Requirement
5.	Allowable Tolerance on overall diameter	+/- 2 mm (maximum) over the declared value in data sheet
6.	Variation in diameter	Not more than 1.0 mm throughout the length of cable.
7.	Ovality at any cross-section	Not more than 1.0 mm
8.	CAGE-CLAMP suitability	To be provided
9.	Color	The outer sheath shall be of blue color.
10.	Others	Repaired cables shall not be acceptable.

Specific Requirements

Specification Requirements	Type-A cable	Type-B cable	Type F & G cable	Type-C cable
A. CONDUCTORS				
Cross section area	0.5 sq. mm			
Conductor material	ANSI type KX	ANSI type SX	Annealed bare copper	ANSI type KX
Colour code	Yellow-Red	Black-Red	As per VDE-815	Yellow-Red
Conductor Grade	As per ANSI MC 96.1		Electrolytic	As per ANSI MC 96.1
No & dia of strands	7x0.3 mm (nom)			
No. of Pairs	2	2	2/4/8/12/16/24 / 48	2
Max. conductor loop resistance per Km (in ohm) at 20 deg. C	As per ANSI MC 96.1		73.4	As per ANSI MC 96.1
Reference Standard	As per ANSI MC 96.1		VDE : 0815	As per ANSI MC 96.1

Specification Requirements	Type-A cable	Type-B cable	Type F & G cable	Type-C cable
B. INSULATION				
Material	Extruded PVC type YI 3			Teflon (i.e. extruded FEP)
Thickness in mm (Min/Max)	0.25/0.35			0.4 / 0.50 (nominal)
Volume Resistivity (Min) in ohm-cm	1 x 10 ¹⁴ at 20 deg. C & 1x10 ¹¹ at 70 deg. C.			2.8x 10 ¹⁴ at 20 deg. C & 2x10 ¹¹ at 205 deg. C.
C. PAIRING & TWISTING				
Max. lay of pairs (mm)	50			
Single layer of binder tape on each pair provided	Each core printed with number or Numbered binder tape to be provided on each pair		Yes	Each core printed with number or Numbered binder tape to be provided on each pair
Bunch (Unit Formation) for more than 4P	N.A		To be provided	N.A
Conductor /pair identification as per VDE0815	N.A.		To be provided	N.A.
D. SHIELDING				
Type of shielding	Al-Mylar tape			
Individual pair shielding	No		To be provided for F-type cable	No
Minimum thickness of Individual pair shielding	No		0.028mm (28 micron)	No
Overall cable assembly shielding	To be provided			
Minimum thickness of Overall cable assembly shielding	0.055 mm (55 micron)			
Coverage /	100% / 20%			

Specification Requirements	Type-A cable	Type-B cable	Type F & G cable	Type-C cable
Overlapping				
Drain wire provided for individual shield	N.A.	Yes (for F-type) Size- 0.5 sqmm No of strands-7 Dia of strands- 0.3mm Annealed Tin coated copper		N.A.
Drain wire provided for overall shield	Yes, Size- 0.5 sqmm, No of strands-7, Dia of strands- 0.3mm, Annealed Tin coated copper			
E. FILLERS (if applicable)				
Non-hygroscopic, flame retardant	To be provided			
F. OUTER SHEATH				
Material	Extruded PVC compound YM1 with FRLS properties		Teflon (i.e. extruded FRP)	
Minimum Thickness at any point	1.8 mm		0.4 mm	
Nominal Thickness at any point	>1.8 mm		0.5 mm	
Resistant to water, fungus, termite & rodent attack	Required			
Minimum Oxygen index as per ASTM D-2863	29 %		N.A.	
Minimum Temperature index as per ASTM D-2863	250 deg.C		N.A.	
Maximum Acid gas generation by weight as per IEC-60754-1	20%		N.A.	
Maximum Smoke Density Rating as per ASTM D-2843	60%		N.A.	
	(defined as the average area under the curve when the results of smoke density test			

Specification Requirements	Type-A cable	Type-B cable	Type F & G cable	Type-C cable
	plotted on a curve indicating light absorption vs. time as per ASTM D-2843)			
Reference standard	VDE207 Part 5, VDE-816			VDE207 Part 6 ASTM D2116
G. Electrical Parameters				
Mutual Capacitance Between Conductors At 0.8 KHz (Max.)	200 nF/km		120 nF/km for F type 100 nF/km for G-type	200 nF/km
Insulation Resistance (Min.)	100 M Ohm/Km			
Cross Talk Figure (Min.) At 0.8 KHz	60 dB		60 dB	60dB
Characteristic Impedance (Max) At 1 KHz	N.A.		320 OHM FOR F-TYPE 340 OHM FOR G-TYPE	N.A.
Attenuation Figure At 1 KHz (Max)	N.A.		1.2 db/km	N.A.
H. COMPLETE CABLE				
Complete Cable assembly	Shall pass Swedish Chimney test as per SEN-SS 4241475 class F3.			N.A.
Flammability	Shall pass flammability as per IEEE-383 read in conjunction to this specification			As per manufacturer's standard subject to employer's approval
I. CABLE DRUM				
Type	Non-returnable wooden drum (wooden drum to be constructed from seasoned wood free from defects with wood preservative applied to entire drum) or steel drum.			

Specification Requirements	Type-A cable	Type-B cable	Type F & G cable	Type-C cable
Length	1000 m \pm 5% for up to & including 12 pairs 500 m \pm 5% for above 12 pairs			

Note: Heat resistant instrumentation cable shall have same specification as of G/F type instrumentation cable as specified above, except that insulation and outer sheath material shall be Teflon and cable shall be suitable for continuous operation at 205 Deg. C.

SPECIFICATION OF OPTICAL FIBER CABLES (OFC)

Optic Fiber cable shall be 4/8/12 core, Electrolytically chrome plated corrugated steel taped (ECCST), fully water blocked with dielectric central member for outdoor/indoor application so as to prevent any physical damage. The cable shall have multiple single-mode or multi-mode fibers on as required basis so as to avoid the usage of any repeaters. The outer sheath shall have Flame Retardant, UV resistant properties and are to be identified with the manufacturer's name, year of manufacturer, progressive automatic sequential on-line marking of length in meters at every meter.

The cable core shall have suitable characteristics and strengthening for prevention of damage during pulling viz. Dielectric central member, Loose buffer tube design, 4 fibers per buffer tube (minimum), Interstices and buffer tubes duly filled with Thixotropic jelly etc. The cable shall be suitable for a maximum tensile force of 2000 N during installation, and once installed, a tensile force of 1000 N minimum. The compressive strength of cable shall be 3000 N minimum & crush resistance 4000 N minimum. The operating temperature shall be – 20 deg. C to 70 deg.C

All testing of the fiber optic cable being supplied shall be as per the relevant IEC, EIA and other international standards.

Bidder to ensure that minimum 100% cores are kept as spares in all types of optical fibre cables.

Cables shall be suitable for laying in conduits, ducts, trenches, racks and under ground buried installation.

Spliced / Repaired cables are not acceptable.

Penetration of water resistance and impact resistance shall be as per IEC standard.

SPCIFICATION OF LT POWER SUPPLY CABLES

All standards, specifications and codes of practice referred to herein shall be the latest editions including all applicable official amendments and revisions as on date of opening of bid. In case of conflict between this specification and those (IS: codes, standards, etc.) referred to herein, the former shall prevail. All the cables shall conform to the requirements of the following standards and codes:

IS: 1554 - I PVC insulated (heavy duty) electric cables for working voltages upto and including 1100V.

IS: 3961 Recommended current ratings for cables

IS: 3975 Low carbon galvanized steel wires, formed wires and tapes for armouring of cables.

IS: 5831 PVC insulation and sheath of electrical cables.

IS: 7098 (Part -I) Cross linked polyethylene

insulated PVC sheathed cables for working voltages upto and including 1100V.

IS: 8130 Conductors for insulated electrical cables and flexible cords.

IS: 10418 Specification for drums for electric cables.

IS: 10810 Methods of tests for cables.

ASTM-D -2843 Standard test method for density of smoke from the burning or decomposition of plastics.

IEC-754

(Part-I) Tests on gases evolved during combustion of electric cables.

IEC-332 Tests on electric cables under fire conditions. Part-3: Tests on bunched wires or cables (Category-B).

TECHNICAL REQUIREMENTS

The cables shall be suitable for laying on racks, in ducts, trenches, conduits and underground buried installation with chances of flooding by water.

All cables including EPR cables shall be flame retardant, low smoke (FRLS) type designed to withstand all mechanical, electrical and thermal stresses developed under steady state and transient operating conditions as specified elsewhere in this specification.

Aluminium conductor used in power cables shall have tensile strength of more than 100 N/ sq.mm. Conductors shall be stranded.

XLPE insulation shall be suitable for a continuous conductor temperature of 90 deg.C and short circuit conductor temperature of 250 deg C. PVC insulation shall be suitable for continuous conductor temperature of 70 deg C and short circuit conductor temperature of 160 deg. C.

The cable cores shall be laid up with fillers between the cores wherever necessary.

It shall not stick to insulation and inner sheath. All the cables, other than single core unarmoured cables, shall have distinct extruded PVC inner sheath of black colour as per IS: 5831.

For single core armoured cables, armouring shall be of aluminium wires/ formed wires. For multicore armoured cables, armouring shall be of galvanized steel as follows:

Calculated nominal dia. of cable under armour	Size and Type of armour
Upto 13 mm	1.4mm dia GS wire
Above 13 & upto 25mm	0.8 mm thick GS formed wire / 1.6 mm dia GS wire
Above 25 & upto 40 mm	0.8mm thick GS formed wire / 2.0mm dia GS wire
Above 40 & upto 55mm	1.4 mm thick GS formed wire /2.5mm dia GS wire
Above 55 & upto 70 mm	1.4mm thick GS formed wire / 3.15mm dia GS wire
Above 70mm	1.4 mm thick GS formed wire / 4.0 mm dia GS wire

The aluminium used for armouring shall be of H4 grade as per IS: 8130 with maximum resistivity of 0.028264 ohm mm² per meter at 20 deg C. The sizes of aluminium armouring shall be same as indicated above for galvanized steel.

The gap between armour wires / formed wires shall not exceed one armour wire / formed wire space and there shall be no cross over / over-riding of armour wire / formed wire. The minimum area of coverage of armouring shall be 90%. The breaking load of armour joint shall not be less than 95% of that of armour wire / formed wire. Zinc rich paint shall be applied on armour joint surface of G.S.wire/ formed wire.

Outer sheath shall be of PVC as per IS: 5831 & black in colour. In addition to meeting all the requirements of Indian standards referred to, outer sheath of all the cables shall have the following FRLS properties.

- (a.) Oxygen index of min. 29 (as per IS 10810 Part-58).
- (b.) Acid gas emission of max. 20% (as per IEC-754-I).
- (c.) Smoke density rating shall not be more than 60 % (as per ASTM D-2843).

Cores of the cables shall be identified by colouring of insulation. Following colour scheme shall be adopted:

- 1 core - Red, Black, Yellow or Blue**
- 2 core - Red & Black**
- 3 core - Red, Yellow & Blue**
- 4 core - Red, Yellow, Blue and Black**

For reduced neutral conductors, the core shall be black

In addition to manufacturer's identification on cables as per IS, following marking shall also be provided over outer sheath.

- (a.) Cable size and voltage grade - To be embossed
- (b.) Word 'FRLS' at every 5 metre - To be embossed
- (c.) Sequential marking of length of the cable in metres at every one metre
-To be embossed / printed

The embossing shall be progressive, automatic, in line and marking shall be legible and indelible. For EPR cables identification shall be printed on outer sheath.

All cables shall meet the fire resistance requirement as per Category-B of IEC 332 Part-3.

Allowable tolerances on the overall diameter of the cables shall be ± 2 mm maximum, over the declared value in the technical data sheets.

In plant repairs to the cables shall not be accepted. Pimples, fish eye, blow holes etc. are not acceptable.

Cable selection & sizing:

Cables shall be sized based on the following considerations:

- (a) Rated current of the equipment.
- (b) The voltage drop in the cable, during motor starting condition, shall be limited to 10% and during full load running condition, shall be limited to 3% of the rated voltage.
- (c) Short circuit withstand capability
This will depend on the feeder type. For a fuse protected circuit, cable should be sized to withstand the let-out energy of the fuse. For breaker controlled feeder, cable shall be capable of withstanding the system fault current level for total breaker tripping time inclusive of relay pickup time.

Cable lengths shall be considered in such a way that straight through cable joints are avoided.

All Cables shall be of armoured type.

All LT power cables of sizes more than 120 sq.mm shall be XLPE insulated and sizes shall be of 1Cx150, 1Cx300, 1Cx630, 3Cx150 & 3Cx240 sq.mm. However for cable sizes up to 120 sq.mm both XLPE insulated & PVC insulated LT power cables are acceptable.

Same cable sizes to be used for same type & rating of motor i.e. if there are three pumps for one application, all three pumps motor should be provided with same cables sizes.

Type Tests

The reports for the following type tests shall be submitted for one size each of LT XLPE and LT PVC Power cables. Size shall be decided by the employer during detailed engineering:

S.No.	Type test	Remarks
	For Conductor	
1.	Resistance test	
2.	Tensile test	For circular non-compacted conductors only
3.	Wrapping test	For circular non-compacted only
	For Armour Wires/ Formed Wires	
4.	Measurement of Dimensions	
5.	Tensile Test	
6.	Elongation test	
7.	Torsion test	For round wires only
8.	Wrapping test	For aluminium wires / formed wires only.
9.	Resistance test	
10(a)	Mass of zinc coating test	For GS Formed wires/wires only
10(b)	Uniformity of zinc coating	For GS Formed wires /wires only
11.	Adhesion test	For GS Formed wires/wires only
	For PVC/XLPE insulation & PVC Sheath	
12.	Test for thickness	

- | | | |
|-----|--|------------------------------------|
| 13. | Tensile strength & elongation before ageing and after ageing tests | |
| 14. | Ageing in air oven | |
| 15. | Loss of mass test | For PVC insulation and sheath only |
| 16. | Hot deformation test | For PVC insulation and sheath only |
| 17. | Heat shock test | For PVC insulation and sheath only |
| 18. | Shrinkage test | |
| 19. | Thermal stability test | For PVC insulation and sheath only |
| 20. | Hot set test | For XLPE insulation only |
| 21. | Water absorption test | For XLPE insulation only |
| 22. | Oxygen index test | For outer sheath only |
| 23. | Smoke density test | For outer sheath only |
| 24. | Acid gas generation test | For outer sheath only |
| | For completed cables | |
| 25. | Insulation resistance test
(Volume resistivity method) | |
| 26. | High voltage test | |
| 27. | Flammability test as per IEC-332 Part-3 (Category-B) | |

Indicative list of tests/checks, Routine and Acceptance tests shall be as per Quality Assurance & Inspection table of LT power cables enclosed.

LT CONTROL CABLES

All standards, specifications and codes of practice referred to herein shall be the latest editions including all applicable official amendments and revisions as on date of opening of bid. In case of conflict between this specification and those (IS : codes, standards, etc.) referred to herein, the former shall prevail. All the cables shall conform to the requirements of the following standards and codes:

IS :1554 - I PVC insulated (heavy duty) electric cables for working voltages up to and including 1100V.

IS : 3961 Recommended current ratings for cables

IS : 3975 Low carbon galvanized steel wires, formed wires and tapes for armouring of cables.

IS : 5831 PVC insulation and sheath of electrical cables.

IS : 8130 Conductors for insulated electrical cables and flexible cords.

IS : 10418 Specification for drums for electric cables.

IS : 10810 Methods of tests for cables.

ASTM-D –2843 Standard test method for density of smoke from the burning or decomposition of plastics.

IEC-754 (Part-I) Tests on gases evolved during combustion of electric cables.

IEC-332 Tests on electric cables under fire conditions. Part-3: Tests on bunched wires or cables (Category-B).

TECHNICAL REQUIREMENTS

The cables shall be suitable for laying on racks, in ducts, trenches, conduits and underground buried installation with chances of flooding by water.

All cables including EPR cables shall be flame retardant, low smoke (FRLS) type designed to withstand all mechanical, electrical and thermal stresses develop under steady state and transient operating conditions as specified elsewhere in this specification.

Conductor of control cables shall be made of stranded, plain annealed copper.

PVC insulation shall be suitable for continuous conductor temperature of 70 deg C and short circuit conductor temperature of 160 deg. C.

The cable cores shall be laid up with fillers between the cores wherever necessary. It shall not stick to insulation and inner sheath. All the cables, other than single core unarmoured cables, shall have distinct extruded PVC inner sheath of black colour as per IS: 5831.

For multicore armoured cables, the armouring shall be of galvanized steel as follows:

Calculated nominal dia

of cable under armour	Size and Type of armour
Up to 13 mm	1.4mm dia GS wire
Above 13 upto 25 mm	0.8 mm thick GS formed wire / 1.6 mm dia GS wire
Above 25 upto 40 mm	0.8mm thick GS formed wire / 2.0mm dia GS wire
Above 40 upto 55mm	1.4 mm thick GS formed wire/2.5mm dia GS wire
Above 55 upto 70 mm	1.4mm thick GS formed wire / 3.15mm dia GS wire
Above 70mm	1.4 mm thick GS formed wire / 4.0 mm dia GS wire

The gap between armour wires / formed wires shall not exceed one armour wire / formed wire space and there shall be no cross over / over-riding of armour wire / formed wire. The minimum area of coverage of armouring shall be 90%. The breaking load of armour joint shall not be less than 95% of that of armour wire / formed wire. Zinc rich paint shall be applied on armour joint surface.

Outer sheath shall be of PVC as per IS: 5831 and grey in colour. In addition to meeting all the requirements of Indian Standards referred to, outer sheath of all the cables shall have the following FRLS properties.

- (a.) Oxygen index of min. 29. (As per IS 10810 Part-58)
- (b.) Acid gas emission of max. 20% (As per IEC-754-I)
- (c.) Smoke density rating shall not be more than 60% during Smoke Density Test as per ASTM D-2843.

Cores of the cables of upto 5 cores shall be identified by colouring of insulation. Following colour scheme shall be adopted.

- 1 core - Red, Black, Yellow or Blue
- 2 core - Red & Black
- 3 core - Red, Yellow & Blue
- 4 core - Red, Yellow, Blue and Black
- 5 core - Red, Yellow, Blue, Black and Grey

For cables having more than 5 cores, core identification shall be done by numbering the insulation of cores sequentially, starting by number 1 in the inner layer (e.g. say for 10 core cable, core numbering shall be from 1 to 10). The number shall be printed in Hindu-Arabic numerals on the outer surfaces of the cores. All the numbers shall be of the same colour, which shall contrast with the colour of insulation. The colour of insulation for all the cores shall be grey only. The numerals shall be legible and indelible. The numbers shall be repeated at regular intervals along the core, consecutive numbers being inverted in relation to each other. When the number is a single numeral, a dash shall be placed underneath it. If

the number consists of two numerals, these shall be disposed one below the other and a dash placed below the lower numeral. The spacing between consecutive numbers shall not exceed 50 mm.

In addition to manufacturer's identification on cables as per IS, following marking shall also be provided over outer sheath:

- (a.) Cable size and voltage grade - To be embossed
 - (b.) Word 'FRLS' at every 5 metre - To be embossed
 - (c.) Sequential marking of length of the cable in metres at every one metre - To be embossed / printed.
- The embossing / printing shall be progressive, automatic, in line and marking shall be legible and indelible. For EPR cables identification shall be printed on outer sheath.

All cables shall meet the fire resistance requirement as per Category-B of IEC- 332 Part-3.

Allowable tolerances on the overall diameter of the cables shall be ± 2 mm maximum over the declared value in the technical data sheets.

In plant repairs to the cables shall not be accepted. Pimples, fish eye, blow holes etc. are not acceptable.

Cable selection & sizing

Control cables shall be sized based on the following considerations:

- (a) The minimum conductor cross-section shall be 1.5 sq.mm.
- (b) The minimum number of spare cores in control cables shall be as follows:

No. of cores in cable	Min. No. of spare cores
2C, 3C	NIL
5C	1
7C-12C	2
14C & above	3

Cable lengths shall be considered in such a way that straight through cable joints are avoided.

All Cables shall be of armoured type.

TYPE TESTS

The reports for the following type tests shall be submitted for one size of control cables. Size shall be decided by the employer during detailed engineering

S. No.	Type Test	Remarks
	For Conductor	
1.	Resistance test	
	For Armour Wires / Formed Wires (If applicable)	
2.	Measurement of Dimensions	
3.	Tensile Test	
4.	Elongation test	
5.	Torsion test	For round wire only
6.	Wrapping test	For aluminium wires / formed wires only.
7.	Resistance test	
8(a).	Mass of zinc Coating test	For GS wires/formed wires only
8(b).	Uniformity of zinc coating	For GS wires/formed wires only
9.	Adhesion test	For GS wires/formed wires only
	For PVC insulation & PVC Sheath	

S. No.	Type Test	Remarks
10.	Test for thickness	
11.	Tensile strength and elongation test	before ageing and after ageing
12.	Ageing in air oven	
13.	Loss of mass test	For PVC insulation and sheath only
14.	Hot deformation test	For PVC insulation and sheath only
15.	Heat shock test	For PVC insulation and sheath only
16.	Shrinkage test	
17.	Thermal stability test	For PVC insulation and sheath only
18.	Oxygen index test	For outer sheath only
19.	Smoke density test	For outer sheath only
20.	Acid gas generation test	For outer sheath only
	For completed cables	
21.	Insulation resistance test(Volume resistivity method)	
22.	High voltage test	
23.	Flammability test as per IEC-332 Part-3 (Category-B)	

INSTRUMENTATION CABLE INTERCONNECTION AND TERMINATION PHILOSOPHY

The cable interconnection philosophy to be adopted shall be such that extensive grouping of signals by large scale use of field mounted Group Junction Boxes (JBs) at strategic locations (where large concentration of signals are available, e.g. valves limit & torque switches, switchgear) is done and consequently cable with higher number of pairs are extensively used. The details of termination to be followed are mentioned in the given Table A.

TABLE A: CABLE TERMINATION TO BE FOLLOWED

Application		Type Of Termination		Type Of Cable
FROM (A)	TO (B)	END A	END B	
Valves/dampers drives (Integral Junction box)	Marshalling / Marshalling – cum Termination Cubicle / local group JB	Plug in connector	Post mount cage clamp type.	G
Transmitters, Process Actuated switches mounted in LIE/LIR	Integral Junction box of LIE/LIR	Plug in connector	Cage clamp (Rail mount) type.	F,G
RTD heads	Local junction box	Plug in connector	Cage clamp (Rail mount) type.	F
Thermocouple	Local junction box / CJC box (if applicable)	Plug in connector	Cage clamp (Rail mount) type.	A, B, C*
Other Field mounted Instrument	Local JB / Group JB	Plug in connector	Cage clamp (Rail mount) type.	F,G
RTD	Temperature transmitter	Plug in connector	Screwed, Cage clamp type	F
Thermocouple	Temperature transmitter	Plug in connector	Screwed, Cage clamp type	A, B, C*
Local Junction box, Temperature Transmitter, Int. Junction box of LIE/ LIR/ MCC/SWGR	Group JB	Cage clamp (Rail mount) type.	Cage clamp (Rail mount) type.	F,G
Local Junction box, Temperature Transmitter, Int. Junction box of LIE/ LIR/ Group JB / MCC/SWGR	Marshalling / Marshalling – cum Termination Cubicle	Cage clamp (Rail mount) type.	Cage clamp (Post mounted) type.	F,G
Marshalling cubicle/ Termination Cabinet	Electronic system cabinet	Cage clamp (Post mounted) type.	Plug-in connector / other system as per Mfr.'s Standard	Internal wiring

Application		Type Of Termination		Type Of Cable
FROM (A)	TO (B)	END A	END B	
Marshalling/ Termination System Cabinets	UCD mounted equipments	Cage clamp (Post mounted) type.	Plug in connector / Cage clamp type (rail mounted).	F,G (with plug-in connect or at one end)
DDCMIS/PLC cabinets	PC, Printers etc.	Plug in connector	Plug in connector	Mfr.'s Standar d

Notes:

1. Normally 10% spare cores shall be provided when the numbers of pairs of cables are more than four pairs, except for pre-fabricated cables which shall be as per manufacturer's standard.
2. For analog signals, individual pair shielding & overall shielding & for Binary signals, only overall shielding of instrumentation cables shall be provided.
3. * For high temperature applications only.
4. For connection between field/JB and DDCMIS marshalling cabinet Minimum 4 pair instrumentation cable shall be used.
5. All the spare cores of instrumentation cable have to be terminated in Marshalling cabinets/ DCS panel end.
6. Not used.

TERMINAL BLOCKS:

Terminal blocks shall be rail mounted/post mounted, cage clamp type with high quality non-flammable insulating material of melamine suitable for working temperature of 105 deg.

The terminal blocks in field mounted junction boxes, temperature transmitters, instrument enclosures/racks, etc., shall be suitable for cage clamp connections. The terminal blocks in Control Equipment Room logic/termination/marshalling cubicles shall be suitable for post mounted cage clamp connection at the field input end. The exact type of terminal blocks to be provided by the Bidder and the technical details of the same including width etc. shall be subject to Employer's approval.

All the terminal blocks shall be provided complete with all required accessories including assembly rail, locking pin and section, end brackets, partitions, small partitions, transparent covers, support brackets, distance sleeves, warning label, marking, etc.

The marking on terminal strips shall correspond to the terminal numbering on wiring diagrams. At least 20% spare unused terminals shall be provided everywhere including local junction boxes, instrument racks/enclosures, termination/marshalling cabinets, etc. All terminal blocks shall be numbered for identification and grouped according to the function.

Engraved labels shall be provided on the terminal blocks.

The terminal blocks shall be arranged with at least 100 mm clearance between two sets of terminal blocks and between terminal blocks and junction box walls.

INTERNAL PANELS/ SYSTEM CABINETS WIRING

Internal panel/cabinet wiring shall be of multi-stranded copper conductor with FRLS PVC insulation without shield and outer sheath meeting the requirements of VDE 0815.

All internal wires shall be provided with tag and identification nos. etched on tightly fitted ferrules at both ends. All wires directly connected to trip devices shall be distinguished by one additional red colour ferrule.

All external connection shall be made with one wire per termination point. Wires shall not be tapped or spliced between terminal points.

All floor slots of desk/panels/cabinets used for cable entrance shall be provided with removable gasketed gland plates and sealing material. Split type grommets shall be used for prefabricated cables.

All the special tools as may be required for solder less connections shall be provided by Bidder.

Wire sizes to be utilised for internal wiring.

(i) Current (4-20 mA), low voltage signals (48V);
Ammeter/Voltmeter circuit, control switches etc.
for electrical system.

0.5 Sq.mm.

(ii) Power supply and internal illumination.

2.5Sq.mm. minimum (shall be as per load requirement).

INSTRUMENTATION CABLE INSTALLATION AND ROUTING

All cables assigned to a particular duct/conduit shall be grouped and pulled in simultaneously using cable grips and suitable lubricants. Cables removed from one duct/conduit shall not be reused without approval of Employer.

Cables shall be segregated as per IEEE Std.-422. In vertically stacked trays, the higher voltage cable shall be in higher position and instrumentation cable shall be in bottom tier of the tray stack. The distance between instrumentation cables and those of other system shall be as follows:

From 11 kV/6.6 kV/3.3 kV tray system	- 914 mm
From 415V tray system	- 610 mm
From control cable tray system	- 305 mm

Cables shall terminate in the enclosure through cable glands. All cable glands shall be properly gasketed. Sealing (to prevent ingress of dust entry and propagation of fire) shall be provided for all floor slots used for cable entrance. Compression cable glands (double for armoured and single for other cables) shall be provided.

The cables emanating from redundant equipment/devices shall be routed through different paths. The above segregation of cables & wiring for redundant equipment's/devices shall be in accordance with IEEE-Std-422.

CABLE LAYING AND ACCESSORIES

CABLE LAYING

1 Cables shall be laid strictly in line with cable schedule.

2 Identification tags for cables.

Indelible tags to be provided at all terminations, on both sides of wall or floor crossing, on each conduit/duct/pipe entry/exit, and at every 20 m in cable trench/tray.

3 Cable tray numbering and marking.

To be provided at every 10m and at each end of cable way & branch connection.

4 No jointing is permissible for Instrumentation cables. For other cables jointing for more than 250 Meters run of cable shall be permitted.

5 Buried cable protection

With concrete slabs; Route markers at every 20 Meters along the route & at every bend.

6 Segregation (physical isolation to prevent fire jumping)

All cable associated with the unit shall be segregated from cables of other Units.

Interplant cables of station auxiliaries and unit critical drives shall be segregated in such a way that not more than half of the drives are lost in case of single incident of fire.

7 Cable clamping

All cables laid on trays shall be neatly dressed up & suitably clamped/tied to the tray. For cables in trefoil formation, trefoil clamps shall be provided.

ELECTRIC ACTUATORS

GENERAL:

Actuators shall be designed for valve operation to ensure proper function in accordance with specifications given below and complying to EN15714-2 or equivalent. All standards, specifications and codes of practice referred to herein shall be the latest editions including all applicable official amendments and revisions.

This sub-section of specification is applicable for following types of electric actuators:

Modulating duty electric actuators:

These shall be provided as per standard practice of OEM of equipment, meeting other requirements of specifications. For specifications of Blade pitch actuators of this chapter.

Electric actuators for valves/ dampers/ gates (other than covered above):

These actuators shall be Non-Intrusive type electric actuators. The interface of these actuators with DDCMIS shall be of two types viz. with Hardwired interface and with Fieldbus interface. The common requirements of both these type of actuators are specified below, specific requirements of Non-Intrusive hardwired actuators are specified at below and specific requirements of Non-Intrusive fieldbus actuators are specified below.

1. COMMON REQUIREMENTS FOR NON INTRUSIVE ELECTRIC ACTUATORS

TYPE:

The actuators shall have integral starters with built in SPP (Single Phasing Preventer). 415 V, 3 phase 3 wire power supply shall be given to the actuator from switch board as applicable through a switch fuse unit. Control voltage of the motor starter shall be 110 V AC / 24 V DC, derived suitably from 415V power supply.

The actuators shall be Non- Intrusive electric actuator. All actuator settings including torque, limit shall be possible without opening the actuator cover and LCD indication shall be available integral to actuator body.

RATING:

(a) Supply Voltage & frequency: 415V +/- 10%, 3 Phase, 3 Wire & 50HZ +/-5%.

(b) Sizing: Open/Close at rated speed against designed differential pressure at 90% of rated voltage.

For ON/OFF type: Three successive open-close operations or 15 minutes, whichever is higher.

For inching type: 150 starts per hour or required cycles, whichever is higher.

CONSTRUCTION:

(a) Enclosure: Totally enclosed weatherproof, minimum IP-68 degree of protection.

(b) Manual Wheel: Shall disengage automatically during motor operation.

MOTOR:

(a) Type : Squirrel cage induction motor suitable for Direct On Line (DOL) starting.

- (b) Enclosure: Totally enclosed, self-ventilated.
- (c) Insulation Class F. Temperature rise 70 Deg C. over 50 Deg C ambient.
- (d) Bearings: Double shielded, grease lubricated antifriction.
- (e) Earth Terminals: Two
- (f) Protection: Single Phasing Protection, Over heating protection through Thermostat (as applicable) and wrong phase sequence protection shall be provided over and above other protection features standard to bidder's design. Suitable means shall be provided to diagnose the type of fault locally.

POSITION/TORQUE TRANSMITTER:

The Position/ Limit measurement shall be done using absolute encoders which will give information of position/ limit in both the directions. Electronic measurement of torque shall be provided.

LOCAL OPERATION:

It shall be possible to operate the actuator locally also. Lockable local/remote selection shall be provided on the actuator.

LCD DISPLAY:

A local LCD display shall be provided to give information regarding actuator alarms, status and valve position indications as a minimum in local.

WIRING:

Suitable voltage grade copper wire.

TERMINAL BLOCK:

For power cables, the grade of TBs shall be minimum 650V.

ACCESSORIES:

All required accessories (if applicable) for calibration / settings/ configuration of various parameters of actuator shall be provided.

2. SPECIFIC REQUIREMENTS FOR NON INTRUSIVE HARDWIRED ACTUATORS

INTERFACES:

For ON-OFF and INCHING type actuators interface with the control system shall be through hardwired signal only.

- (a) Open/Close command, open/ close status and disturbance monitoring signal (common contact for Overload, Thermostat, control supply failure, L/R selector switch at local & other protections operated) shall be provided hardwired.
- (b) The actuator shall be able to accept open/close command at 24V DC with max. 2.5VA load from control system. Accordingly suitable isolated interface in the actuator shall be provided.
- (c) Open/close command termination logic shall be suitably built inside actuator.

TERMINAL BOX:

Suitable terminals/ connectors, integral to actuator, for terminating instrumentation & power cables shall be provided. Necessary glands for power cables and instrumentation cables shall be provided.

3. SPECIFIC REQUIREMENTS FOR NON INTRUSIVE FIELDBUS ACTUATORS

INTERFACES:

For ON-OFF and INCHING type actuators interface with the control system shall be through fieldbus network.

- (a) Open/ close commands, open/ close feedback status, disturbance signal etc. shall be available to the Control System through the fieldbus network along with diagnostics. The detailed diagnostics including the actuator operating data shall be available to the DDCMIS through the fieldbus network.
- (b) All actuators shall be Foundation Fieldbus/ Profibus compatible. However the exact protocol shall be based on finalized protocol of DDCMIS. If Profibus DP protocol is envisaged then actuator shall have two (redundant) Profibus DP ports for connecting the redundant Profibus DP cables. That is if one profibus cable is cut or not working/ not available, then complete actuator functionality shall be available through the second redundant cable without any manual intervention.
- (c) Open/close command termination logic shall be suitably built inside actuator.

4. TERMINAL BOX:

Suitable terminals/ connectors, integral to actuator, for terminating fieldbus cables and power cables shall be provided. Necessary glands for power cables and armored fieldbus cables shall be provided.

INDICATIVE VENDOR LIST

FLUE GAS DESULPHURISATION (FGD) SYSTEM PACKAGE

TECHNICAL SPECIFICATION
SECTION-VI

Disclaimer for Indicative Vendor List

- 1.1 Reasonable efforts have been made to collate the sub-vendors proposed by the various main contractors from time to time against different Projects/Packages and accepted by NTPC for various items. However, in case of error/omission, if any, and represented by the successful bidder this will be addressed during the execution of the contract based on the material evidence available with NTPC / Main Contractor.
- 1.2 The approved sub-vendor list drawn is not based on NTPC driven enlistment process but based on the sub- vendors proposed by various Main Contractors. As such, it is possible that some of the Suppliers/Manufacturers who may be involved in similar work/process may not be appearing in the list as such sub-vendors may not have been proposed by Main Contractors against NTPC Contracts.
- 1.3 In case the successful bidder chooses to propose additional sub-vendors with relevant experience after the award of the contract such sub-vendors will be considered in terms of Clause no: 19.1 of GCC, provided the proposals are received sufficiently in time: 90 days prior to ordering date of a Bought Out Items/Start of Manufacturing so as not to impede the progress of the contract.
- 1.4 Sub-vendors have been grouped under different categories of items. It is possible that an item characterized by certain specific features such as range and type required as per Main Contractor's design requirements may not be in the range of the listed sub-vendor's manufacturing process/capability. As such the main contractor to ascertain the vendor's capability to meet his specific requirements before considering a sub-vendor.
- 1.5 It is to be noted by the bidders that any shortfall in contract performance attributable to the sub-vendor listed will not absolve the contractor from his contractual obligations in any manner.

- 1.6 The approval was granted based on the evaluation of relevant capabilities and facilities possessed by the sub-vendor at the time of evaluation. Also, some of the sub-vendors may not be active. As such, the successful bidder is to carry out his own due diligence before considering the listed sub-vendor for subletting: the current status of the sub-vendor, the continued availability of productive resources including Human Resources.
- 1.7 The list of sub-vendors is periodically revised to include new sub-vendors. Such a revision may also see a deletion of certain sub-vendors who may have been disqualified on grounds of inadequate performance or banned in line with NTPC's banning policy. The then current list will be shared with the successful bidder immediately on award.

Project : Package : EGD Package Supplier : Contract No.:		MECHANICAL ITEMS- INDICATIVE SUB-VENDOR LIST LIST OF ITEMS REQUIRING QUALITY PLAN AND SUB-SUPPLIER APPROVAL					Doc No Rev No Date Page		
Sl No	ITEM	QP/ Insp. Cat.	QP No:	QP Sub, approval Sch.	Proposed sub-supplier	Place	Sub- Supplier approval status / category	Sub- supplier Details submission sch	Remark
1	Slurry re-circulation Pumps				Indiana Conveyors Pvt.Ltd., Quality Engineering Works	Jejuri, Pune Kokalla	A A		Refer Sub-QR List Refer Sub-QR List
2	Oxidation Blowers				Main Contractor Approved Sub.vendors				
3	Wet Limestone Grinding Mill				Jindal	Ghaziabad	A		
4	Slurry Pumps				TATA STEEL	Jamshedpur	A		
5	Agitators				SAIL	Rourkela	A		
6	Vacuum Belt Filters				Surya Roshni	Bahadurgarh	A		
7	Booster Fan				Welspan	Anjar	A		
8	Bucket Elevator				MSJ	Raigarh	A		
9	Absorber tank				Gujarat Infra	Vadodara	A		
10	Atmospheric Tanks / Air Receiver Tanks				Indus Tube	G. B. Nagar	A		
11	Spiral welded upto 1600 mm.				Jindal Industries APL Apollo	Hissar Sikandrabad	A A		
					Babu Pipes	Sikandrabad	A		
					ESMT	Ahmedabad	A		
					Ratnamani	Anjar / Chattral	A		
					JCO Gas Pipes	Chindwara	A		
					SAIL	Rourkela	A		
					Surya Global	Kutch	A		

INDICATIVE

QUALITY PLAN

APPROVAL

PACKAGE:		INDICATIVE SUB VENDOR LIST				NTPC DOC NO	
Sl No.	Item	QP/ Insp. Cat.	ACCEPTABLE SUPPLIER AS PER DATABASE	PLACE OF MANUFACTURING	APPROVAL STATUS	REVISION NO DATE	REMARKS
1	APRON FEEDER WITH DRIBBLE CONVEYOR		TKII	HYDERABAD	A		UPTO 2400 TPH
			L&T	KANSBAHL	A		UPTO 2200 TPH
			ELECON	VV NAGAR	A		UPTO 2200 TPH
			TENOVA INDIA	CHENNAI	A		UPTO 2200 TPH
			TRF	JAMSHEDPUR	A		UPTO 2400 TPH
			MCNALLY SAYAJI	KUMARDHUBI	A		UPTO 2200 TPH
			L & T	KANCHEEPURAM	A		UPTO 2250 TPH
			ELECON	V V NAGAR	A		UP TO 1750 TPH
			FAMAK FAMUR S.A.	POLAND	A		UP TO 1750 TPH
			TKII	PUNE	A		UPTO 1950 TPH
			TRF	JAMSHEDPUR	A		UP TO 2475 TPH
			PENNSYLVANIA CRUSHER CORPORATION	USA	A		UP TO 1760 TPH
			AMERICAN PULVERISER	USA	A		UPTO 1875 TPH
2	PADDLE FEEDER						
3	RING GRANULATOR						

NTPC		INDICATIVE SUB VENDOR LIST			NTPC DOC NO	
SI No.	Item	QP/ Insp. Cat.	ACCEPTABLE SUPPLIER AS PER DATABASE	PLACE OF MANUFACTURING	REVISION NO	
					DATE	
					APPROVAL STATUS	
					REMARKS	
			TKII	PUNE	A	<p>UP TO 2035 TPH 1. Vetting of GA drawing and QAP shall be done by TKIS -Germany. Inspection and trial run for first Ring Granulator & Vibrating Screen Feeder at TKII work's and installation and trial run at Kudgi site for first Ring Granulator & Vibrating Screen Feeder shall be done in presence of TKIS - Germany.</p> <p>2. TKIS-Germany shall submit performance back up guarantee on their letter head duly signed by authorized signatory for Ring granulator and vibrating screen feeder, in addition to performance guarantee by TKII.</p> <p>3. Spherical roller bearings and raw materials for screen plate for Ring granulator and double balance exciter units, carbon shaft, coupling between exciters and support springs for Vibrating screen feeder shall be imported from TKIS - Germany/ sources approved from TKIS - Germany.</p>
			TRF	JAMSHEDPUR	A	UP TO 1800 TPH. TRF SHALL GIVE EXTENDED WARRANTY OF 5 YEARS OVER & ABOVE CONTRACTUAL WARRANTY
			L&T	KANSBAHAL	A	UP TO 1600 TPH
			ELECON	V V NAGAR	A	UP TO 1320 TPH
			MCNALLY SAYAJI	KUMARDHUBI	A	UPTO 1000 TPH
			TECHNO VIBRAZIONI	ITALY	A	UPTO 1875 TPH
4	VIBRATING SCREEN/FEEDER		ELECON	V V NAGAR	A	UP TO 1320 TPH

INDICATIVE SUB VENDOR LIST		NTPC DOC NO	
SI No.	Item	PACKAGE:	REVISION NO
SI No.	Item	QP/ Insp. Cat.	DATE
SI No.	Item	ACCEPTABLE SUPPLIER AS PER DATABASE	APPROVAL STATUS
SI No.	Item	PLACE OF MANUFACTURING	REMARKS
		GENERAL KINEMATICS	A
		USA	UP TO 2000TPH
		TKII	UP TO 2035 TPH 1. Vetting of GA drawing and QAP shall be done by TKIS -Germany. Inspection and trial run for first Ring Granulator & Vibrating Screen Feeder at TKII work's and installation and trial run at Kudgi site for first Ring Granulator & Vibrating Screen Feeder shall be done in presence of TKIS - Germany. 2. TKIS-Germany shall submit performance back up guarantee on their letter head duly signed by authorized signatory for Ring granulator and vibrating screen feeder, in addition to performance guarantee by TKII. 3. Spherical roller bearings and raw materials for screen plate for Ring granulator and double balance exciter units, carbon shaft, coupling between exciters and support springs for Vibrating screen feeder shall be imported from TKIS - Germany/ sources approved from TKIS - Germany.
		TRF	A
		JAMSHEDPUR	UP TO 1800 TPH. TRF SHALL GIVE EXTENDED WARRANTY OF 5 YEARS OVER & ABOVE CONTRACTUAL WARRANTY
		MONALLY SAYAJI	A
		KUMARDHUBI	UPTO 1210 TPH
		BENGAL TOOLS	A
		KOLKATA	
		TKII	A
		PUNE	
		ELECON	A
		V V NAGAR	
5	TRAVELLING TRIPPER		

SI No.		Item	PACKAGE:	INDICATIVE SUB VENDOR LIST			NTPC DOC NO
QP/ Insp. Cat.		ACCEPTABLE SUPPLIER AS PER DATABASE	PLACE OF MANUFACTURING	REVISION NO	DATE	APPROVAL STATUS	REMARKS
		MBE		KUMARDHUBI	A		
		TRF		JAMSHEDPUR	A		
		INDIANA CONVEYOR		PUNE	A		FOR UP TO 50 TPH RATING LIME HANDLING / GYPSUM HANDLING PLANT.
		HMTC		KOLKATA	A		
		L & T - MACNIL		CHENNAI	A		
		L & T		KANSBAHAL	A		
		L & T - EWL		KANCHEEPURAM	A		
6		FABRIC BELTING(FR GRADE)		KOLKATA	A		UPTO 2200 MM WIDTH
		IMASS S.A		GREECE	A		UPTO 2400 MM WIDTH
		MRF		CHENNAI	A		UPTO 1600 MM WIDTH
		SEMPELTRAN NIRLON		MUMBAI	A		UPTO 1600 MM WIDTH
		HINDUSTAN RUBBER		SILVASA	A		UPTO 1600 MM WIDTH
		NORTHLAND RUBBER		SONEPAT	A		UPTO 2200 MM WIDTH.
		SOMI CONVEYOR		JODHPUR	A		UPTO 2000 MM WIDTH
		RAVASCO TRANSMISSION LTD.		VAPI	A		UPTO 2200 MM WIDTH
		ORIENTAL RUBBER		PUNE	A		UPTO 2200 MM WIDTH
		FORECH		CHENNAI	A		UPTO 2000 MM WIDTH
		YOKOHAMA		JAPAN	A		UPTO 2400 MM WIDTH
7		STEEL CORD BELT (FR GRADE)		KOLKATA	A		UPTO 2400 MM WIDTH
		YOKOHAMA		JAPAN	A		UPTO 2400 MM WIDTH
		IMASS S.A		GREECE	A		UPTO 2400 MM WIDTH
		FORECH		CHENNAI	A		UPTO 2000 MM WIDTH
		CAMOPLAST		KOREA	A		UPTO 2400 MM WIDTH
8		IDLERS		V V NAGAR	A		
		ELECON		V V NAGAR	A		

PACKAGE:		INDICATIVE SUB VENDOR LIST			NTPC DOC NO	
Sl No.	Item	QP/ Insp. Cat.	ACCEPTABLE SUPPLIER AS PER DATABASE	PLACE OF MANUFACTURING	REVISION NO	
					DATE	
					APPROVAL STATUS	
					REMARKS	
			MBE	KUMARDHUBI	A	
			KALI	KUMBAKONAM	A	
			AMPS	JAMSHEDPUR	A	
			A.ADAK	HOWRAH	A	
			BENGAL TOOLS	KOLKATA	A	
			V V N MFG	V V NAGAR	A	Upto 150 NB Dia
			TKII	HYDERABAD / PUNE	A	
			PROMAC	BANGALORE	A	
			L & T - EWL	KANCHEEPURAM	A	
			ROLLWELL	HINDUPUR	A	
			INDIANA CONVEYORS	PUNE	A	
9	PIPES FOR IDLERS IS 9285		MAIN CONT. APPRD SOURCES	HOSUR	N	SUBJECT TO VALID BIS LICENCE
10	BEARINGS FOR IDLERS		MAIN CONT. APPRD SOURCES	HOSUR	N	
11	PULLEYS		ELECON	V V NAGAR	A	
			PROMAC	BANGALORE	A	
			MBE	KUMARDHUBI	A	
			BENGAL TOOLS	KOLKATA	A	
			TNS HEAVY	CHENNAI	A	
			KALI	THIRUBUVANAM	A	
			TKII	HYDERABAD / PUNE	A	
			L & T - EWL	KANCHEEPURAM	A	
			V V N MFG	V V NAGAR	A	Upto 800 NB Dia
			R K INDUSTRIES	NEW DELHI	A	UP TO 800 MM DIA
			ROLLWELL	HINDUPUR	A	
			INDIANA CONVEYORS	PUNE	A	
			RISHI INDUSTRIES	SONEPAT	A	
			WAHEGURU	KOLKATA	A	
			SUDEEP RUBBER	V V NAGAR	A	
			DEBIP RUBBER	KOLKATA	A	
			CORI RUBBER	CHENNAI	A	
			PRADEEP RUBBER	CHAKULA	A	
			PRESIDENCY RUBBER	KOLKATA	A	
			THEJO ENGG	CHENNAI	A	
			CENTURY RUBBER	KOLKATA	A	
13	BEARING FOR PULLEYS		MAIN CONT. APPRD SOURCES		A	Upto size 560
14	HELICAL GEARBOX		SHANTI GEARS	COIMBATORE	A	
			ELECON	V V NAGAR	A	
			SIEMENS (FLENDER)	KHARAGPUR	A	
			PREMIUM TRANSMISSION LTD	PUNE/FALTA	A	Up to size 710 / 450

PACKAGE:		INDICATIVE SUB VENDOR LIST			NTPC DOC NO	
Sl No.	Item	QP/ Insp. Cat.	ACCEPTABLE SUPPLIER AS PER DATABASE	PLACE OF MANUFACTURING	REVISION NO	
					DATE	
					APPROVAL STATUS	
					REMARKS	
15	PLANETARY GEARBOX		SIEMENS (FLENDER) NEW ALLENBURY WORKS ELECON SIEMENS (FLENDER) MOVENTAS BREVINI SEW EURODRIVE GMBH & CO.	GERMANY KOLKATA V V NAGAR GERMANY GERMANY ITALY GERMANY	A A A A A A A	
16	FLUID COUPLING (SCOOP AND TRACTION TYPE)		FLUIDOMAT PTL ELECON	DEWAS AURANGABAD V V NAGAR	A A A	Scoop type upto SC-1330 SCOOP TYPE UPTO PST 1:150 Scoop type upto model ESC 760.
17	GEARED COUPLING		VOITH MAIN CONTRACTOR APPROVED SOURCES	HYDERABAD	A	SCOOP TYPE UPTO SVNL 1330
18	FLEXIBLE COUPLINGS		MAIN CONTRACTOR APPROVED SOURCES			
19	FLAP GATE, R&P GATE AND ROD GATE*		TKI MINING & MATERIAL HANDLING UNITED-TECHNOMAC MBE PREREQ HMTG ELECON	PUNE KOLKATA PUNE KUMARDHUBI HOWRAH KOLKATA V V NAGAR	A A A A A A A	
20	VENTILATION SYSTEM		MAIN CONTRACTOR APPROVED SOURCES			FAN FROM NTPC APPROVED SOURCES
21	VENTILATION FANS		MARATHON ELECTRIC MOTOR(I) LTD DUVENT S K SYSTEM ALMONARD TCF NADI HOWDEN SOLYVENT	KOLKATA BANGALORE SONIPAT CHENNAI CHENNAI CHENNAI	A A A A A A	

PACKAGE:		INDICATIVE SUB VENDOR LIST				NTPC DOC NO	
Sl No.	Item	QP/ Insp. Cat.	ACCEPTABLE SUPPLIER AS PER DATABASE	PLACE OF MANUFACTURING	APPROVAL STATUS	REVISION NO DATE	REMARKS
			KHAITAN	KOLKATA	A		
			C B DOCTOR	AHMEDABAD	A		
22	DUST EXTRACTION SYSTEM		MAIN CONTRACTOR APPROVED SOURCES				BOIs(Fan, Pump, Strainer, Gate valve, NRV, Butterfly valve, Control panel, Actuator, Pressure Gauge and Temperature Gauge) from NTPC approved source
23	HORIZONTAL CENTRIFUGAL PUMP		KIRLOSKAR BROS LTD.	KIRLOSKARWADI	A		
			WILO MATHER & PLATT	PUNE / KOLHAPUR	A		
			SAM TURBO	COIMBATORE	A		UP TO 1500 CUM/HR
			FLOWMORE	GHAZIABAD	A		
			BEST AND CROMPTON	CHENNAI	A		
			JYOTI	VADODARA	A		
			WPIL	GHAZIABAD	A		
			KISHORE PUMPS	PUNE	A		UP TO 500 CUM/HR
			GRUNDFOS PUMPS INDIA PVT LTD	CHENNAI	A		HORIZONTAL UP TO 30 KW (FOR APPLICATIONS WHERE NPSH IS NOT REQUIRED)
			SINTECH PRECISION	GHAZIABAD	A		UP TO 315 KW
			KSB	PUNE / NASHIK	A		
			FLOWSERVE INDIA CONTROLS PVT LTD	COIMBATORE	A		HORIZONTAL CENTRIFUGAL PUMP UP TO 75 KW
24	SUMP PUMP		SAM TURBO	COIMBATORE	A		
			KISHORE PUMPS	PUNE	A		
			MCNALLY SAYAJI	BANGALORE	A		up to 80 M3/hr capacity and head up to 25 MWC
			SU MOTORS	MUMBAI	A		
			AQUA MACHINERY	AHMEDABAD	A		
			FLOWMORE PUMP	GHAZIABAD	A		
			DARLING PUMP	INDORE	A		
25	CI GATE/GLOBE/CHECK VALVES (MAIN CONTRACTOR APPROVED SOURCE UP TO CLASS 300 & SIZE 600 NB)		LEADER	JALANDHAR	A		GATE 300NB AND PN16,GLOBE 150 NB AND PN16 & 450NB PN10,CHECK 600NB CLASS #150
			A V VALVES	AGRA	A		UPTO 500 NB PN16
			H SARKER	HOWRAH	A		
			BANKIM	HOWRAH	A		
			KBL	KONDHAPURI	A		SWING CHECK UP TO 600 MM
			HAWA ENGINEERS	AHMEDABAD	A		

Sl No.	Item	QP/ Insp. Cat.	ACCEPTABLE SUPPLIER AS PER DATABASE	PLACE OF MANUFACTURING	NTPC DOC NO	INDICATIVE SUB VENDOR LIST	
						REVISION NO	DATE
						APPROVAL STATUS	REMARKS
			WEIR BDK	HUBLI			Conventional CCS Gate / Globe / Check Valves up to 600MM and Class # 1500, CSS Gate/ Globe/ Check Valves up to 200MM and Class # 600, up to 500MM and class #300 , FCS Gate / Globe / Check Valves up to 50MM and Class # 2500.
26	CS/ FS GATE/GLOBE/CHECK VALVES(MAIN CONTRACTOR APPROVED SOURCE UP TO CLASS 300 & SIZE 600 NB)		LEADER OSWAL INDUSTRIES FOURESS FOURESS	JALANDHAR AHMEDABAD AURANGABAD THANE		A	CS GATE 600MM CLASS#600, SS GLOBE ONLY FOR CCS VALVES UPTO 300 NB CS 600 NB CL 150, 300 NB CLASS 300, 400 NB CLASS 600 AND 150 NB CLASS 600.
			BHEL IVP	GOINDWAL		A	GATE UP TO 600NB CLASS 150, 500 NB CLASS 300, 300 NB CLASS 600, GLOBE 250 NB CLASS 400, CHECK 500 NB CLASS 150, 300 CLASS 300, 150NB CLASS 600.
			HITECH ENGG PVT LTD.	AHEMDABAD		A	250 NB CLASS 150, 50 NB CLASS 800.
			STEEL STRONG	RABALE		A	GATE VALVE- CS UPTO 600NB, SS UPTO 300NB; GLOBE VALVE- CS/SS UPTO 300NB; CHECK VALVE- CS UPTO 600NB, SS UPTO 250NB
			KSB PUMPS LTD	COIMBATORE		A	300NB CLASS 2500.
			HAWA ENGINEERS	AHMEDABAD		A	CS UPTO 450NB, CLASS #300, 500NB CLASS 150 AND SS 300NB CLASS 300, FCS / FSS 50 NB CLASS 800.
			NITON VALVES INDIA PVT LTD	NAVI MUMBAI / AURANGABAD		A	CS GATE 900 NB CLASS 600, GLOBE 400 CLASS 300, CHECK 300 NB CLASS 600.
			L&T VALVES LIMITED	COIMBATORE		A	650 MM CLASS 600, 50 NB CLASS 800.
			WEIR BDK	HUBLI		A	Conventional CCS Gate / Globe / Check Valves up to 600MM and Class # 1500, CSS Gate/ Globe/ Check Valves up to 200MM and Class # 600, up to 500MM and class #300 , FCS Gate / Globe / Check Valves up to 50MM and Class # 2500.

PACKAGE:		INDICATIVE SUB VENDOR LIST			NTPC DOC NO	
Sl No.	Item	QP/ Insp. Cat.	ACCEPTABLE SUPPLIER AS PER DATABASE	PLACE OF MANUFACTURING	REVISION NO	
					DATE	
					APPROVAL STATUS	
					REMARKS	
27	BALL VALVES (MAIN CONTRACTOR APPROVED SOURCE UP TO CLASS 800 AND SIZE 100 NB)		WEIR BDK	HUBLI	A	SS Ball valves up to 500MM and class #600, CS Ball Valves up to 250 MM and class# 900, CS/ SS Ball valves up to 100 MM and class # 1500.
			MICRO FINISH VALVES PVT. LTD.	HUBLI	A	400NB CLASS#600 AND UP TO 600NB CLASS#300
			FLOW CHEM INDUSTRIES	KALOL	A	100NB CLASS#600,200NB CLASS#300, 50 NB CLASS#800
			BRAY CONTROLS (ZHEJIANG) CO. LTD	CHINA	A	UP TO 100 NB CLASS#300
			L&T VALVES LIMITED	COIMBATORE	A	UPTO 150NB, CLASS #150/300, AND UPTO 50NB, CLASS #800
			PRECISION ENGG CO VALVES PVT LTD	MASIK	A	FCS UP TO 50NB CLASS 800, CCS UP TO 400NB CLASS 150.
			BELGAUM AQUA VALVE PVT LTD	BELGAON	A	FCS UP TO 50NB CLASS 800, CCS UP TO 200NB CLASS 150.
			G M ENGINEERING PRIVATE LTD	RAJKOT	A	UP TO 400 NB AND CLASS #600
			HAWA ENGINEERS	AHMEDABAD	A	UPTO 100NB, CLASS #150
			LEADER ENGG	JULLUNDHAR	A	
			BOMBAY METAL	MUMBAI	A	
			SANT VALVES	JULLUNDHAR	A	
			TRACTEL TRFOR	PALWAL	A	UPTO 20 TON
			LIFTING EQUIPMENT	DELHI	A	UPTO 12 TON
			ARMSSELL	BANGALORE	A	UPTO 5 TON
			CENTURY CRANE ENGINEERS PVT. LTD	BALLABHGARH	A	UPTO 7.5 TON
			HERCULES HOIST	RAIGAD	A	UPTO 15 TON
			REVA INDUSTRIES	FARIDABAD	A	
			EDDY CRANE	PUNE	A	UPTO 10 TON
			CONSOLIDATED HOIST	SATARA /PUNE *	A	*PUNE FOR ELECTRIC HOIST UPTO 15 TONS
			ELECTROTHERAPHY	RISHRA	A	UPTO 15 TON FOR ELECTRIC HOIST ONLY
			HERCULES HOIST	RAIGAD	A	UPTO 15 TON FOR ELECTRIC HOIST ONLY
			TUBRO FERGUSSON	KOLKATA	A	UPTO 5 TON FOR ELECTRIC HOIST
			PRAYAS ENGG (PBL)	V V NAGAR	A	UPTO 10 TON FOR ELECTRIC HOIST ONLY

Sl No.	Item	PACKAGE:	INDICATIVE SUB VENDOR LIST		NTPC DOC NO		
			QP/ Insp. Cat.	ACCEPTABLE SUPPLIER AS PER DATABASE		PLACE OF MANUFACTURING	REVISION NO
							DATE
			ALPHA SERVICES	ALWAR	A	SINGLE GIRDER EOT CRANE & ELECTRIC HOIST UPTO 15 TON ONLY. GEARBOX FROM NTPC APPROVED SOURCES FOR EOT CRANE.	
			CENTURY CRANE ENGINEERS PVT. LTD	BALLABHGARH	A		
			ARMSEL	BANGALORE	A	UPTO 10 TON EOT & UPTO 15 T ELECTRIC HOIST	
			TRACTEL TIRFOR	PALWAL	A	UPTO 15 TON FOR ELECTRIC HOIST AND UPTO 10 TON FOR EOT	
			MILLARS INDIA	KARANSAR	A		
			AVON CRANES	GURGAON	A		
			GRIP ENGINEERS	HYDRABAD	A	GEARBOX FROM NTPC APPROVED SOURCES FOR EOT CRANE.	
			GRIP ENGINEERS	FARIDABAD	A	UPTO 20 TON ELECTRIC HOIST ONLY	
			INDIAN FORGING AND STAMPING	JAMSHEDPUR	A		
			HINDUSTAN FORGE	MUMBAI	A		
			BAY FORGE	CHENNAI	A		
			VIKRANT FORGINGS	KOLKATA	A		
			SAIL	DURGAPUR	A		
			BHARAT FORGE	PUNE	A		
			TAYO ROLLS	JAMSHEDPUR	A		
			PUNJAB HAMMER	MANDI GOVINDGARH	A		
			FORGING INDIA	KOLKATA	A		
			PAHLAD RAT FORGINGS	KANPUR	A		
			HEC	RANCHI	A		
			VISHNU FORGINGS	NASIK	A		
			PRAYAS CASTINGS	VV NAGAR	A		
			STEELCAST	BHAVNAGAR	A		
			KOLHAPUR STEEL	KOLHAPUR	A		
			AQUA ALLOYS	KOLHAPUR	A		
			MARTOPEARL ALLOYS	HYDERABAD	A		
			UP STEEL	MUZAFFAR NAGAR	A	NOT FOR Mn STEEL CASTING	
			GS ALLOYS	VIJAYWADA	A	NOT FOR Mn STEEL CASTING	
			VOSSLOH BEEKAY CASTINGS	BHILAI	A	UPTO 250 KG. NOT FOR Mn STEEL CASTING	
			RAIPUR CASTINGS	BILASPUR	A	UPTO 250 KG.	
31	ALLOY STEEL/CARBON STEEL FORGINGS						
32	CS AND ALLOY STEEL CASTINGS						

NTPC		INDICATIVE SUB VENDOR LIST		NTPC DOC NO	
PACKAGE:		INDICATIVE SUB VENDOR LIST		REVISION NO	
Sl No.	Item	QP/ Insp. Cat.	ACCEPTABLE SUPPLIER AS PER DATABASE	PLACE OF MANUFACTURING	DATE
Sl No.	Item	QP/ Insp. Cat.	ACCEPTABLE SUPPLIER AS PER DATABASE	PLACE OF MANUFACTURING	APPROVAL STATUS
REMARKS					
33	MISC. FABRICATED ITEMS, TECHNOLOGICAL STRUCTURE		MAIN CONTRACTOR APPROVED SOURCES		PHYSICAL ASSESSMENT SHALL BE DONE BY THE MAIN CONTRACTOR BASED ON CRITERIA/CHECKLIST PROVIDED BY NTPC
34	BELT CLEANER & SKIRT BOARD SEALING (BACKING PLATE, RUBBER BLOCKS), FESTOON TROLLEY		MAIN CONT. APPROVED SOURCES		
35	SCRAPPER,SHEAVES,TAKEUP TROLLEY,TAKEUP COMPONENTS (THIMBLE,BULL DOG GRIP,TURN BUCKLE,COUNTER WEIGHTS), SCREW TAKEUP, RAIL, MANUAL RAIL CLAMP		MAIN CONTRACTOR APPRD SOURCES		
36	WIRE ROPE		BOMBAY WIRE ROPES	MUMBAI	A
			BHARAT WIRE ROPE	MUMBAI	A
			USHA MARTIN	RANCHI	A
37	PAC		VOLTAS	THANE/SILVASSA	A
			CARRIER AIRCON	GURGAON	A
			BLUESTAR	SILVASSA	A
38	SPLIT WINDOW AC		MAIN CONTRACTOR APPRD SOURCES		
39	QUICK RELEASE COUPLING, SHRINK DISC COUPLINGS, SLIP RING , CLUTCH COUPLING, COMPRESSION COUPLINGS		MAIN CONTRACTOR APPRD SOURCES		
40	AIR RELEASE VALVE, FLOAT VALVES		MAIN CONTRACTOR APPRD SOURCES		
41	DUST SUPPRESSION SYSTEM (PLAIN WATER & DRY FOG)		MAIN CONTRACTOR APPRD SOURCES		BOIs (Pump,Strainer,Pipes, Nozzle, Gate,Globe,Check valve, Butterfly valve, Actuator,Motors,Control Panel, Pressure Reducing valve ,Solenoid valve, Pressure Gauge and Temperature Gauge, Pressure switch, Level switch, Flow switch, Transmitter) from NTPC approved sources
42	BELT VULCANISER		NILOS	CHENNAI	A
			THEJO ENGG	CHENNAI	A
43	CAST IRON CASTING		MAIN CONT. APPRD SOURCES		
44	PLUMMER BLOCK		MAIN CONT. APPRD SOURCES		

PACKAGE:		INDICATIVE SUB VENDOR LIST				NTPC DOC NO
Sl No.	Item	QP/ Insp. Cat.	ACCEPTABLE SUPPLIER AS PER DATABASE	PLACE OF MANUFACTURING	APPROVAL STATUS	REMARKS
45	SAFETY RELIEF VALVE		LEADER SPIRAX MARSHALL FISHER SANMAR	JULLANDHAR PUNE CHENNAI	A A A	
46	STRAINERS		MAIN CONTRACTOR APPRD SOURCES			
47	BUTTER FLY VALVE (MAIN CONTRACTOR APPROVED SOURCE UP TO CLASS 150 & SIZE 600 NB)		INTERVALVE POONAWALA LTD WEIR BDK PENTAIR VALVES CRANE FLOW PROCESS FLOWSERVE INDIA CONTROLS FOURES S ENGINEERING (INDIA) LIMITED KBL R & D MULTIPLE ADVANCE	PUNE HUBLI HALOL SATARA CHENNAI BANGALORE KONDHAPURI VALSAD GAGRET	A A A A A A A A	SGI / CI / D2 1400MM PN10, SGI / CI 1000MM PN16, CS/SS 500MM PN16, SS 400MM CLASS#300, UPTO 2800NB, PN 6 CI / DI butterfly valve up to 1000MM and PN16 AND up to 1800MM and PN10, CCS UP TO 1050MM CLASS 150 AND up to 1800MM and PN16 SS - UP TO 400NB PN-16 , FABRICATED 800MM CLASS#150. FOR SS UP TO 500 NB PN-10, CI- UP TO 900NB PN-10, UP TO 500NB PN-16, 450MM CLASS#300., UPTO 2800NB, PN6. CI & SS UPTO 500 NB PN16, 600 NB PN10 UPTO 600 NB, CI ONLY PN 16/ CLASS 150 CAST SGI/CI/ MS FABRICATED- UP TO 1200 PN-10, UP TO 350 PN-16 ,2400 MM PN6/CLASS150 SS - UP TO 300NB PN-10, UPTO 2700NB CLASS # 75 CAST SGI/CI/CS 1400 MM PN16 , SS 300 MM PN16 , 1800MM CLASS 150, MS FABRICATED 900 NB PN40,2800NB, PNG. CAST SGI/CI/MS FABRICATED- UP TO 1800 MM PN-10/CLASS # 75 , 1100MM PN25,1400MM CLASS#150 , UPTO 2800NB CLASS # 75 SOFT SEATED, CONCENTRIC BFV OF CI/ CS/ SS OF SIZE UPTO 250MM AND PRESSURE RATING UPTO CLASS #150.

PACKAGE:		INDICATIVE SUB VENDOR LIST			NTPC DOC NO	
Sl No.	Item	QP/ Insp. Cat.	ACCEPTABLE SUPPLIER AS PER DATABASE	PLACE OF MANUFACTURING	REVISION NO	
					DATE	
					APPROVAL STATUS	
					REMARKS	
			ADVANCE	GREATER NOIDA	A	METAL SEATED, TRIPLE ECCENTRIC, SS BFV OF SIZE UPTO 100NB, AND PRESSURE RATING UPTO CLASS #300.
			BRAY CONTROLS INDIA PVT LTD	VADODARA	A	UP TO 400NB CLASS 150 / PN16
			BRAY CONTROLS (ZHEJIANG) CO. LTD	CHINA	A	UP TO 400 NB CLASS#600
			L&T	KANCHIPURAM	A	UPTO 400NB, CLASS #150
			INSTRUMENTATION LTD.	PALAKKAD	A	UPTO 2200NB CLASS # 75
			HAWA ENGINEERS	AIHMERABAD	A	CI/ CS & FABRICATED UPTO 1200MM, CLASS #150, SS UPTO 250MM, CLASS#150
48	MS FITTINGS (BLACK / GI) AS PER IS 1239 PART-2		MAIN CONTRACTOR APPRD SOURCES			
49	MS ERW PIPES AS PER IS 1239 / IS 3589 (UPTO 600 NB)		SAIL	ROURKELA	A	
			MAHARASHTRA SEAMLESS	RAIGAD	A	200 NB TO 500 NB ERW PIPES AS PER IS 3589
			INDUS TUBES	G.B.NAGAR	A	UPTO 300 NB AS PER IS 1239/3589
			SURYA ROSHNI	BAHADURGARH	A	UPTO 400 NB ERW PIPES AS PER IS 1239/3589
			JINDAL	GHAZIABAD	A	UPTO 350 NB ERW PIPES AS PER IS 1239/3589
			JINDAL	JANGALPUR	A	UPTO 500 NB FOR BLACK PIPE
			JINDAL INDUSTRIES LTD.	HISSAR	A	UP TO 300 NB ERW BLACK PIPE AS PER IS 1239/3589
			APL APOLLO TUBES LTD.	SIKANDRABAD	A	MS pipes (Black & GI) as per IS 1239 & MS pipes (Black & GI) as per IS 3589 up to 250 NB size, 8 mm thickness and Grade up to Fe 410.
			LLYODS LINE PIPES LTD.	THANE	A	MS pipes (Black & GI) as per IS 1239 & MS pipes (Black) as per IS 3589 up to 350 NB size, 8 mm thickness and Grade up to Fe 410.
			DADU PIPES	SIKANDRABAD	A	UPTO 300 NB ERW BLACK PIPES

PACKAGE:		INDICATIVE SUB VENDOR LIST			NTPC DOC NO	
Sl No.	Item	QP/ Insp. Cat.	ACCEPTABLE SUPPLIER AS PER DATABASE	PLACE OF MANUFACTURING	REVISION NO	
					DATE	
					APPROVAL STATUS	
					REMARKS	
			TATA	JAMSHEDPUR	A	UPTO 150 NB ERW PIPES AS PER IS 1239
			RATNAMANI	KUTCH	A	ERW PIPES AS PER IS 3589 UPTO 400 NB
			WELPSUN	ANJAR	A	UPTO 400 NB ERW PIPES AS PER IS 1239/3589
50	FORGED/FORMED FITTINGS		GUJARAT INFRA PIPES	BARODA	A	
			EBY	UMBAI	A	
			N.L.HAZRA	KOLKATA	A	
			MS FITTINGS	KOLKATA	A	
			TRUE FORGE	FARIDABAD	A	
			TUBE PRODUCTS	BARODA	A	
			PIPEFIT ENGINEERS	BARODA	A	
			SIDDARTH & GAUTAM	FARIDABAD	A	
51	MATERIAL FOR DUCTING, DUCTING SUPPORT, GRILLS, LOUVRE, DAMPERS, PRE & FINE FILTERS (no of filters < 100 each), EARTHING MATERIAL (MS ROUND BAR)		MAIN CONTRACTOR APPRO SOURCES			
52	CI PRESSURE RELIEF/REDUCING VALVE		DARLING MUESCO	AHMEDABAD	A	
			LEADER	JULLUNDHAR	A	
			FISCHER SANMAR	PUNE	A	
			SPIRAX MARSHALL	PUNE	A	
			FAINGER LESSER	AURANGABAD	A	
			EATON POWER	PUNE	A	
53	HYDRAULIC POWER PACK		BOSCH-REXROTH	AHMEDABAD	A	
			HAGGLUNDS	SWEDEN	A	
			MAHA HYDRAULICS	CHENNAI	A	
			L & T HYDRAULICS	BANGALORE	A	EXCEPT FOR STACKER RECLAIMER
54	HYDRAULIC CYLINDER		VELJAN	HYDERABAD	A	
			WIPRO	BANGALORE	A	
			EATON POWER	PUNE	A	
			L & T HYDRAULICS	BANGALORE	A	

PACKAGE:		INDICATIVE SUB VENDOR LIST			NTPC DOC NO
Sl No.	Item	QP/ Insp. Cat.	ACCEPTABLE SUPPLIER AS PER DATABASE	PLACE OF MANUFACTURING	REVISION NO
					DATE
					APPROVAL STATUS
					REMARKS
55	HYDRAULIC MOTOR		BOSCH-REXROTH POCLAIN HYDRAULICS HAGGLUNDS PARKER CALZONI MAHA HYDRAULICS KAWASAKI	AHMEDABAD FRANCE SWEDEN ITALY CHENNAI UK	A A A A A A
56	HYDRAULIC PIPE & PIPE FITTING		MAIN CONTRACTOR APPRD SOURCES		
57	SCREW TYPE AIR COMPRESSORS		ELGI ATLAS COPCO INGERSOL RAND INDIA KOBELCO AERZENER ELGI SWAMI	COIMBATORE BELGIUM. AHMEDABAD JAPAN GERMANY COIMBATORE NOIDA	A A A A A A A
58	BLOWER		KAY INTERNATIONAL EVEREST KULKARNI POWER TOOLS	SONEPAT NEW DELHI / BAHADURGARH SHIROL	A A A
59	PNEUMATIC CYLINDER		NUCON ROTEX	HYDERABAD MUMBAI	A A

PACKAGE:		INDICATIVE SUB VENDOR LIST			NTPC DOC NO	
Sl No.	Item	QP/ Insp. Cat.	ACCEPTABLE SUPPLIER AS PER DATABASE	PLACE OF MANUFACTURING	REVISION NO	
					DATE	
					APPROVAL STATUS	
					REMARKS	
			SCHRADER DUNCAN	PUNE	A	UPTO 350 NB
			VAAS INDUSTRIES	CHENNAI	A	UPTO 300 NB
			ORBINOX	COIMBATORE	A	UPTO 300 NB
60	REFRIGERANT TYPE DRIER		SUMMIT'S HYGRONICS	COIMBATORE	A	Upto 11893 m3/hr
			TRIDENT	COIMBATORE	A	Upto 10000 m3/hr
			MELCON	GREATER NOIDA	A	Upto 7250 m3/hr
			DELAIR	GURGAON	A	Upto 7500 m3/hr
			ATLAS COPCO	BELGIUM	A	Upto model FD 1200
61	DESSICANT TYPE AIR DRYER		DELAIR	GURGAON	A	
			INDCON	DELHI	A	
			MELCON	GREATER NOIDA	A	
			SUMMIT	COIMBATORE	A	
			TRIDENT	COIMBATORE	A	
62	AIR RECEIVER(MAIN CONTRACTOR APPROVED SOURCE FOR < 10 KSC PRESSURE)		UNITED ENGINEERS	NASHIK	A	
			TEMASME VESELEX	NOIDA	A	
			INTEGRATED ENGINEERS	MUMBAI	A	
			LABACUS HEAT TRANSFER	FARIDABAD	A	
			PARKAIRE	DELHI	A	
			GEM	COIMBATORE	A	
63	ROTARY FEEDER		INDURE	SAHIBABAD	A	
			DCIPS	KOLKATA	A	
			MELCO	FARIDABAD	A	
			MCMALLY SAYAJI	ASANSOL/KUMARDHUBI	A	
			MACAWBER BEEKAY	KESHWANA	A	
			EXPONENTIAL ENGINEERING	PUNE	A	

PACKAGE:		INDICATIVE SUB VENDOR LIST			NTPC DOC NO
Sl No.	Item	QP/ Insp. Cat.	ACCEPTABLE SUPPLIER AS PER DATABASE	PLACE OF MANUFACTURING	REVISION NO
					DATE
					APPROVAL STATUS
					REMARKS
64	PLAIN WATER SPRAY NOZZLE/SPRINKLERS FOR DS SYSTEM		SPRAYING SYSTEM	BANGALORE	A
			F.HARLEY	KOLKATA	A
			EAGLE AGRO	RAJKOT	A
			INDIANA GRATINGS PVT. LTD.	PUNE	A
			JINDAL STEEL & POWER LTD.	RAIGARH	A
			BABY ENGG. PVT. LTD.	TRICHY	A
			REGIONAL ENGG. WORKS	TRICHY	A
			AJANTHA FABS	MATHUR	A
			CAPACITE STRUCTURES LTD.	THANE	A
			MIURA INFRASTRUCTURE PVT LTD.	BHILAI	A
			SHIVAM HITECH STEELS PVT. LTD	BHILAI	A
			TECHNOFAB MANUFACTURING LTD.	CHENNAI	A
			JSW SEVERFIELD STRUCTURES LTD(JSS)	BELLARY	A
			ALLIANCE INTEGRATED METALIKS LTD(AIML)	RAJPURA	A
			ATMASTCO PVT LTD	DURGAPUR	A
			APEX BUILDSYS LTD	NAGPUR	A
			COREFAB PROJECTS PVT LTD	BHILAI	A
			KOTHARI CHEMICALS	BHILAI	A
			FEDDERS LLOYD CORPORATION LTD	SIKANDRABAD	A
			ARCELOR MITTAL DHAMM PROCESSING PVT LTD	RANIPET	A
			ARTSON ENGINEERING	NASIK	A
65	SHOP FABRICATED STRUCTURE				

PACKAGE:		INDICATIVE SUB VENDOR LIST			NTPC DOC NO	
					REVISION NO	
					DATE	
Sl No.	Item	QP/ Insp. Cat.	ACCEPTABLE SUPPLIER AS PER DATABASE	PLACE OF MANUFACTURING	APPROVAL STATUS	REMARKS
			ARTSON ENGINEERING	NAGPUR	A	

LEGENDS

1. SYSTEM SUPPLIER/SUB-SUPPLIER APPROVAL STATUS CATEGORY (SHALL BE FILLED BY NTPC)

A – For these items proposed vendor is acceptable to NTPC. To be indicated with letter "A" in the list alongwith the condition of approval, if any.

DR – For these items "Detailed required" for NTPC review. To be identified with letter "DR" in the list.

NOTED – For these items vendors are approved by Main Supplier and accepted by NTPC without specific vendor approval from NTPC. To be identified with "N"

INDICATIVE VENDOR LIST FOR NTPC

ANNEXURE-12

Spares Wet ball mill FEEDER FOR KAHALGAON

SL NO		ITEM DESCRIPTION	QTY	UOM	Remarks	MAT CODE
1	GRAVIMETRIC FEEDER	BELT	2	SET	1 SET=REQUIREMENT FOR ONE EQUIPMENT	BA9789262019
2		BELT DRIVE MOTOR	1	NO		BA9789262027
3	GRAVIMETRIC FEEDER	BELT DRIVE REDUCER	1	NO		BA9789262035
4	GRAVIMETRIC FEEDER	SPEED REDUCER ASSEMBLY	1	SET		BA9789262043
5	GRAVIMETRIC FEEDER	WEIGHING INSTRUMENTS	1	SET		BA9789262051
6	GRAVIMETRIC FEEDER	FEEDER WEIGHING ROLL	1	NO		BA9789262060
7	GRAVIMETRIC FEEDER	GRAVIMETRIC FEEDER GATE ACTUATOR ASSEMBLY	1	NO		BA9789262078
8	GRAVIMETRIC FEEDER	COUNTER ASSEMBLY OF FEEDER COMPLETE	1	NO		BA9789262086
9	GRAVIMETRIC FEEDER	FEEDER HEAD PULLEY ASSEMBLY	1	NO		BA9789262094
10	C&I-MEASURING INSTRUMENTS	(I) PROCESS ACTUATED SWITCHES(PRESSURE, DIFFERENTIAL PRESSURE, FLOW, LEVEL, TEMP) (II) LIMIT SWITCHES (FOR PNEUMATIC AND MANUAL VALVES)	10	%	10% OR 2 NO. OF EACH TYPE AND MODEL, WHICHEVER IS MORE.	BA9789262108
11	WBM-ELECTRICAL ACTUATORS	ACTUATORS	1	set	1 NO OF EACH TYPE AND RATING	BA9789262159
12	WBM-ELECTRICAL ACTUATORS	ELECTRONIC PCB OF ALL TYPES	10	%	10% OF EACH TYPE & MODEL	BA9789262124
13	WBM-ELECTRICAL ACTUATORS	ABSOLUTE ENCODER (REPLACEABLE PART)	5	%	5% OF EACH TYPE & MODEL	BA9789262132
14	WBM-ELECTRICAL ACTUATORS	ELECTRONIC TORQUE SENSOR	5	%	5% OF EACH TYPE & MODEL	BA9789262140