

**NTPC LIMITED**

**KAHALGAON SYPS STAGE-I (4x210 MW) R&M OF ESP PACKAGE**

**TECHNICAL SPECIFICATION**

**FOR**

**HVAC SYSTEM**

**SPECIFICATION NO.: - PE-TS-455-571-15000A-A002 (REV-00)**



**BHARAT HEAVY ELECTRICALS LIMITED  
POWER SECTOR  
PROJECT ENGINEERING MANAGEMENT  
SECTOR-16A, PLOT NO.-25, NOIDA, INDIA**



**TITLE:**  
**KAHALGAON STPS (R&M) STAGE-1  
(4X210MW)  
HVAC SYSTEM**

**SPECIFICATION No: PE-TS-455-571- 15000A-A002**  
**REV. 00**

**CONTENTS**

**This Technical specification consists of two sections:**

**SECTION - I**

<b>SUB- SECTIONS</b>	<b>TITLE</b>	<b>Page No</b>
<b>Sub-Section-A</b>	INTENT OF SPECIFICATION	3
<b>Sub-Section-B</b>	PROJECT INFORMATION	6
<b>Sub-Section-C</b>	TECHNICAL SPECIFICATIONS	
	<b>Sub Section-C1</b> SPECIFIC TECHNICAL REQUIREMENT	7
	<b>Sub Section-C2</b> CUSTOMER SPECIFICATION	15
	<b>Sub Section-C3</b> TECHNICAL SPECIFICATION (ELECTRICAL PORTION)	34
<b>Sub Section-D</b>	STANDARD TECHNICAL SPECIFICATIONS	75
<b>Sub Section-E</b>	ANNEXURE-I LIST OF MAKES OF SUB-VENDOR ITEMS	86
	ANNEXURE-II MANDATORY SPARE LIST	99
	ANNEXURE-III PAINTING & COLOUR SCHEME	99
	ANNEXURE-IV LIST OF TOOLS & TACKLES	99
	ANNEXURE-V MASTER DRAWING LIST WITH SCHEDULE OF SUBMISSION	99
	ANNEXURE-VI FORMAT FOR OPERATION AND MAINTENANCE MANUAL	100
	ANNEXURE-VII SITE STORAGE AND PRESERVATION	104

**SECTION - II**

<b>SUB SECTIONS</b>	<b>TITLE</b>	<b>Page No</b>
<b>Sub Section-1</b>	INSPECION AND TESTING WITH STANDARD QUALITY PLAN	120
<b>Sub Section-2</b>	LIST OF DOCUMENTS TO BE SUBMITTED WITH BID	124
<b>Sub Section-3</b>	COMPLIANCE CUM CONFIRMATION CERTIFICATE	125
<b>Sub Section-4</b>	PRE BID CLARIFICATION SCHEDULE	127
<b>Sub Section-5</b>	DEVIATION SHEET (COST OF WITHDRAWL)	128
<b>Sub Section-6</b>	REFERENCE DRAWING/DOCUMENTS	129



**KAHALGAON STPS (R&M) STAGE-I  
(4x210MW)  
TECHNICAL SPECIFICATION FOR  
HVAC SYSTEM**

**SPECIFICATION No: PE-TS-455-571-  
15000A-A002**

**SECTION : I**

**Sub Section: A**

**REV. 00**

**SECTION-I  
SUB-SECTION-A  
INTENT OF SPECIFICATION**



**KAHALGAON STPS (R&M) STAGE-I  
(4x210MW)  
TECHNICAL SPECIFICATION FOR  
HVAC SYSTEM**

**SPECIFICATION No: PE-TS-455-571-  
15000A-A002**

**SECTION : I**

**Sub Section: A**

**REV. 00**

**1.0 INTENT OF SPECIFICATION**

- 1.1 The specification covers Supply part, Services part and Mandatory spares , comprising of submission of “As Built” drawings and O&M manuals, manufacture, fabrication,, assembly, inspection / testing at vendor's & sub-vendor’s works, painting, maintenance tools & tackles (as applicable), fill of lubricants & consumables, mandatory spares along with spares for erection, start up and commissioning as required, forwarding, proper packing, shipment and delivery at site, unloading, handling, transportation & storage at site, in-site transportation, assembly, erection & commissioning, final painting at site, minor civil work, trial run at site and carrying out Performance guarantee / Functional / Demonstration tests at site (As applicable), training of customer/client O&M staff and handover in flawless condition of the package to the end customer complete with all accessories for the total scope defined as per BHEL NIT & tender technical specification as specified above, amendment & agreements till placement of order for KAHALGAON STPS STAGE-I (4x210MW) (R&M OF ESP PACKAGE)..
- 1.2 The contractor shall be responsible for providing all material, equipment & services, which are required to fulfil the intent of ensuring operability, maintainability, reliability and complete safety of the complete work covered under this specification, irrespective of whether it has been specifically listed herein or not. Omission of specific reference to any component / accessory necessary for proper performance of the equipment shall not relieve the contractor of the responsibility of providing such facilities to complete the supply, erection and commissioning, performance and guarantee/demonstration testing of **HVAC SYSTEM**.
- 1.3 It is not the intent to specify herein all the details of design and manufacture. However, the equipment shall conform in all respects to highest standards of design, engineering and workmanship and shall be capable of performing the required duties in a manner acceptable to purchaser who will interpret the meaning of drawings and specifications and shall be entitled to reject any work or material which in his judgement is not in full accordance herewith.
- 1.4 The extent of supply under the contract includes all items shown in the drawings, notwithstanding the fact that such items may have been omitted from the specification or schedules. Similarly, the extent of supply also includes all items mentioned in the specification and /or schedules, notwithstanding the fact that such items may have been omitted in the drawing. Similarly, the extent of supply also includes all terms required for completion of the system and not withstanding that they may have been omitted in drawings / specifications or schedules.
- 1.5 The general term and conditions, instructions to tenderers and other attachment referred to elsewhere are made part of the tender specification. The equipment materials and works covered by this specification is subject to compliance to all attachments referred to in the specification. The bidder shall be responsible for and governed by all requirements stipulated herein.



**KAHALGAON STPS (R&M) STAGE-I  
(4x210MW)  
TECHNICAL SPECIFICATION FOR  
HVAC SYSTEM**

**SPECIFICATION No: PE-TS-455-571-  
15000A-A002**

**SECTION : I**

**Sub Section: A**

**REV. 00**

- 1.6 While all efforts have been made to make the specification requirement complete & unambiguous, it shall be bidders' responsibility to ask for missing information, ensure completeness of specification, to bring out any contradictory / conflicting requirement in different sections of the specification and within a section itself to the notice of BHEL and to seek any clarification on specification requirement in the format enclosed under section II of the specification **within 10 days of receipt of tender documents**. In absence of any such clarifications, in case of any contradictory requirement, the more stringent requirement as per interpretation of Purchaser / Customer shall prevail and shall be complied by the bidder without any commercial implication on account of the same. Further in case of any missing information in the specification not brought out by the prospective bidders as part of pre-bid clarification, the same shall be furnished by Purchaser/ Customer as and when brought to their notice either by the bidder or by purchaser/ customer themselves. However, such requirements shall be binding on the successful bidder without any commercial & delivery implication.
- 1.7 The bidder's offer shall not carry any sections like clarification, interpretations and /or assumptions.
- 1.8 Deviations, if any, should be very clearly brought out clause by clause along with cost of withdrawal in the format attached with GCC (Annexure-II Deviation sheet (Cost of withdraw), otherwise, it will be presumed that the vendor's offer is strictly in line with NIT specification.
- 1.9 In the event of any conflict between the requirements of two clauses of this specification documents or requirements of different codes and standards specified, Section - C shall prevail over section – D, however more stringent requirement as per the interpretation of the owner shall apply.
- 1.10 In case all above requirements are not complied with, the offer may be considered as incomplete and would become liable for rejection.
- 1.11 For definition of word like Contractor, bidder, supplier, vendor, Customer/ Purchaser Employer, consultant, please referred relevant clause of General Conditions of Contract (GCC).



**KAHALGAON STPS (R&M) STAGE-I  
(4x210MW)  
TECHNICAL SPECIFICATION FOR  
HVAC SYSTEM**

**SPECIFICATION No: PE-TS-455-571- 15000A-A002**

**SECTION : I**

**Sub Section : B**

**REV. 00**

**SECTION: I  
SUB-SECTION: B**

**PROJECT INFORMATION**

Kahalgaon Super Thermal Power Station (KHSTPS) is located in the district Bhagalpur of Bihar State. The Station is around 250km from the state capital Patna. The station is having four (4) units of 210MW each with a total installed capacity of 840MW; Stage-I comprising 4 units commissioned in the year 1992-96. Stage-I Units (U#1, U#2, U#3 & U#4) have completed around 20-24 years of service.

In line with the pollution control norms, NTPC now intends taking up Renovation & Modernization (R&M) and augmentation work on these existing ESP's of (4x210MW) units, along with Retrofitting of ESPs by enhancement of their Collection Area, so that these units are able to comply with the particulate emission control norms prevailing in the area under various operating conditions / contingencies. This specification is intended for such R&M of four (4) sets of Electrostatic Precipitators of 4x210 MW units of KhSTPS.

The current work involves renovation of the ESPs at Site which is being executed by BHEL. The bidder's scope pertains to the supply and erection & commissioning of the air-conditioning and ventilation system as per the details specified elsewhere in the specification.



**KAHALGAON STPS (R&M) STAGE-I  
(4x210MW)  
TECHNICAL SPECIFICATION**

**SPECIFICATION No: PE-TS-455-571- 15000A-  
A002**

**SECTION : I**

**Sub Section : C**

**REV. 00**

**SECTION: I**

**SUB SECTION: C1**

**TECHNICAL SPECIFICATION**



**KAHALGAON STPS (R&M) STAGE-I  
(4x210MW)  
TECHNICAL SPECIFICATION**

**SPECIFICATION No: PE-TS-455-571-15000A-A002**

**SECTION : I**

**SUB-SECTION : C 1**

**REV. 00**

**1. FUNCTION**

The purpose of the system is to provide HVAC for 4 X 210 MW STAGE-I ESP R&M NTPC KAHALGAON for ESP Control Rooms.

**2. SYSTEM DESCRIPTION**

Basic engineering of AC system such as Heat load, capacities and layouts of equipment have already been finalized with customer.

Equipment /Layout drawings for specific makes of respective equipment (as per Table 1) have been finalized and are attached in sub section 7 of this specification. In case bidder finalizes these makes, bidder is not required to submit these drawings/documents afresh. However, bidder shall be required to endorse the documents attached in sub section 7 (Appendix 1) during detail engineering.

Further, it may be noted that bidder has the option to choose different makes (other than those for which drawings/ documents have been attached in the specification) for these items from the list of makes of sub vendor items attached at Sub Section E.

In such a scenario, Bidder will have to submit Engineering document for such items in line with details mentioned in respective equipment GA/documents attached at Appendix 1.

However, any data which is proprietary in nature or standard for the model offered by OEM or not specifically insisted in this tender specification of the respective equipment may be updated/ modified suitably.

**Table -1**

<b>ITEM</b>	<b>MAKE</b>
Air Cooled Ductable Split AC	VOLTAS
Supply Axial Fans	SARLA
Fresh Air Fans/Propeller Fans	MARATHON
Motors	ABB
Drain Pipe	TATA/JINDAL
Grill/Diffuser	SYSTEM AIR
GI Sheet	TATA STEEL/TISCO/BHUSHAN/JINDAL/JSW STEEL
Thermal Insulation	TWIGA
Acoustic Insulation	TWIGA
ACDB	SWITCHING CIRCUIT

**3. SYSTEM CAPACITY AND CONFIGURATION**

- a) Two (2 nos.) Air cooled Ductable Split AC(1W+1SB) of 5 TR Capacity(Actual), along with indoor and outdoor units, piping, insulation, cabling, etc. for the AC area of each unit.
- b) Industrial type ventilation fans (Supply air fans fitted with filters) and gravity damper for Non- AC areas of ESP Control Room Building, complete with starter unit, cowl and



**KAHALGAON STPS (R&M) STAGE-I  
(4x210MW)**

**TECHNICAL SPECIFICATION**

**SPECIFICATION No: PE-TS-455-571-15000A-A002**

**SECTION : I**

**SUB-SECTION : C 1**

**REV. 00**

bird/insect protection, pre-filters and fine filters as applicable as per latest industry practices.

- c) Required power cables for the above ACs and ventilation fans, from distribution board to each equipment along with required local motor starters, switches, tray/conduits etc. for each equipment. Power distribution board is in scope of supply of bidder.

**4. LAYOUT CONSIDERATION**

- I. 2 Nos. (1w+1S) Air cooled Ductable Split AC units shall be located below false ceiling of control room of ESP Control Room building of each unit.  
Approved Duct and equipment layout is enclosed in reference documents.
- II. Ventilation fans and Dampers for Non AC areas of Control room building shall be as per layout enclosed in reference documents.

**5. EQUIPMENT DETAILS (if different make is chosen for respective equipment)**

**5.1. AIR COOLED DUCTABLE SPLIT AIR CONDITIONER**

Air cooled Ductable Split Air Conditioning units consisting of:

- Hermetic Compressor with Air cooled condenser
- Evaporator Cooling coil, blower unit and refrigerant circuit
- Refrigerant pipeline with insulation
- Drain pipeline
- Power and control cables
- Suitable capacity stabilizer
- MCB/PDB
- Handheld remote with remote holder
- The Ductable split A/C unit shall have one condenser (outdoor) unit and one Evaporator (indoor) unit to suit the control rooms. The capacity (TR) of the indoor unit shall be the actual capacity (100%) as the split units are intended to be used. Outdoor units shall comprise of compressor, cooling fan, condenser. Indoor unit comprising of blower, filter, cooling coil shall be mounted in attractive, corrosion resistant enclosures.
- The compressor shall be of hermetic scroll / rotary type. The contractor shall indicate the safety measures provided for the compressor and motor. The condenser shall be air cooled copper coil with Aluminium fins type with ample condensing surface. The cooling coil shall be of direct expansion type with copper tubes and mechanically bonded aluminium fins; it shall be sufficiently deep for effective cooling. The refrigerant circuit between (outdoor) Condenser unit and (indoor) Evaporator unit shall be carried out as per site conditions. The circuit shall include thermostatic expansion valve/ linear expansion valve, filter drier and



**KAHALGAON STPS (R&M) STAGE-I  
(4x210MW)**

**TECHNICAL SPECIFICATION**

**SPECIFICATION No: PE-TS-455-571-  
15000A-A002**

**SECTION : I**

**SUB-SECTION : C 1**

**REV. 00**

liquid line shut off valve. It shall be protected by Hi-Lo pressure start. Fan shall be provided to handle the conditioned air. The fan shall be dynamically balanced and its operation shall be smooth and quiet. It shall be complete with direct drive motor. The bearings shall be self-lubricating type.

**5.2. Wall Mounted Axial flow fan**

- a) These fans shall have single piece cast aluminium impeller with blades of aero foil design. It shall be finished all over and balanced dynamically as per AMCA standard. Impeller shall be mounted directly on the motor shaft.
- b) The fan casing shall be of heavy gauge construction, properly reinforced for rigidity. It shall be provided with suitable supports. Access door shall be provided in the casing for easy access to motor and impeller Suitable arrangement for mounting the motor shall be provided.
- c) Rain protection cowls will be designed to suit wall mounted air supply fans for protecting fans/motors from rain. It shall be provided with bird screen.
- d) Inlet cone or bell & outlet cone shall be provided.
- e) Accessories such as bird protection screen, inlet louvers vibration, isolators, back draft dampers etc. shall be provided as per requirement.
- f) Motors shall be totally enclosed type, complying with the electrical specification (subsection C2 of Section-I).
- g) The speed of the fan shall not exceed 960 rpm for fan with impeller diameter above 450 mm and 1440 rpm for fan with impeller diameter 450 mm and less. However, for fans having static pressure of 30 mm WC or above the speed of the fan shall not exceed 1440 rpm for fan with impeller dia. above 450 mm and 2800 rpm for fan with impeller diameter 450 mm and less. The first critical speed of rotating assembly shall be at least 25% (percent) above rated speed.

**5.3. Sheet Metal Work**

- a) Air distribution would be done through ducting system, grilles and diffusers. All ducting shall be designed on equal friction method and fabricated as per IS: 655
- b) Supply air diffusers / grilles (Frame and Louvers of Diffuser/Grilles shall be of extruded aluminum of 1.2 mm thick section, duly powder coated) with volume control dampers.
- c) For other details please refer to relevant clauses of section C2-A, customer specifications

**5.4. Piping Valves etc.**

- a) Refer to relevant clauses of section C2-A, customer specifications.

**5.5. ELECTRICAL ITEMS**

Refer to relevant clauses of section C2-A, customer specifications and electrical portion of specifications.



**KAHALGAON STPS (R&M) STAGE-I  
(4x210MW)**

**TECHNICAL SPECIFICATION**

**SPECIFICATION No: PE-TS-455-571-  
15000A-A002**

**SECTION : I**

**SUB-SECTION : C 1**

**REV. 00**

**6. GENERAL**

- 1) Basis of design all calculations including heat load calculations for summer seasons, equipment selection criterion, layout drawings/ schemes/G.A. dwg and documents like data sheet/ technical particulars etc are subject to Customer approval during detail engineering stage.
- 2) Vendor to furnish characteristic curves for all major equipment offered indicating duty point during detailed engineering.
- 3) All drawings and documents shall be computer based.
- 4) All commissioning spares & consumables for trouble free operation till handing over, shall be provided.
- 5) Quality Requirements in the Technical Specification are indicating minimum requirements for inspection and testing. Vendor shall note that quality plan is subject to Customer & BHEL approval during detail engineering stage. Standard QP format is enclosed in the technical specification.
- 6) Indicative list of makes is enclosed as per Annexure-I however this equipment / items shall be subject to Customer & BHEL approval during detail engineering Stage.
- 7) Inserts or any support arrangement for fixing ducting, fans, piping etc. shall not be provided by BHEL. Necessary supports may be taken from nearest structure / walls / roofs / floors etc. by Vendor.
- 8) Fixing frame works for diffusers and grilles in the scope of Vendor.
- 9) Anchor fastener shall be used by vendor for fixing duct pipes etc. wherever applicable.
- 10) Necessary supports and structures / frames etc. as required for supporting the duct / piping / equipment etc. as lump-sum basis is in the scope of Vendor and no unit rates shall be applicable for these items.
- 11) Drain piping within room up to the drain point to be provided by the Vendor.
- 12) Vendor to furnish schedule of power and control cables. Vendor to furnish cable termination details interconnection drawings etc. during detail engineering stage.
- 13) The tools and machine required for erection of equipment shall be arranged by Vendor.
- 14) Tools & tackles as required for regular maintenance shall be supplied by Vendor.
- 15) Instruments required for performance testing of various equipment / system of the package shall be arranged by Vendor at site.



**KAHALGAON STPS (R&M) STAGE-I  
(4x210MW)**

**TECHNICAL SPECIFICATION**

**SPECIFICATION No: PE-TS-455-571-  
15000A-A002**

**SECTION : I**

**SUB-SECTION : C 1**

**REV. 00**

- 16) Instrument for testing shall be calibrated by Air-conditioning plant supplier before taking up testing.
- 17) Pressure gauges shall have provision for air venting. Three way valves shall be used which shall have air venting provision.
- 18) The guarantee tests shall cover but not limited to the following rated parameters for smooth operation of air conditioning and ventilation system.
  - Performance test of the Air conditioning system shall be carried out at site after proper installation. The site test shall include performance testing of equipment for minimum 72 continuous hours in summer or monsoon and minimum 24 continuous hours in winter. Bidder, as may be required to carry out site tests shall arrange all instruments, tools etc.
  - All calibrated instruments to be used for the tests at manufacturer's works/site shall be arranged by the bidder. Any Electrical/C&I items and accessories like junction box, glands etc. shall be included by vendor in his scope.
- 19) Tender drawings enclosed form the part of specification and the bidder shall check the space requirements for installing the equipment as per the specification and layout requirements given in the specifications.
- 20) In the event of any conflict between the requirements of two clauses of this specification documents or requirements of different codes and standards specified, the more stringent requirement as per the interpretation of the owner shall apply.
- 21) Bidder to note that BHEL reserve the right for drg/doc submission through web based Document Management System. Bidder would be provided access to the DMS for drg/doc approval and adequate training for the same. Bidder to ensure proper internet connectivity at their end.
- 22) Quality requirements in the Technical specification are minimum requirements for inspection and testing. Vendor to note that quality plans are subject to Customer approval during detail engineering stage. Standard QP format is enclosed in the technical specification.
- 23) Sealing of duct opening, grouting of foundation / foundation bolts etc. including special type of grouting like GPX2 etc. are in the scope of Air-conditioning system vendor.
- 24) Vendor shall fix the equipment using anchor fasteners to secure the equipment obtain parameters related to vibration and noise.
- 25) Supplier to furnish drawings/ documents as per the dwg. / documents distribution as per project requirement.
- 26) Each motor terminal box shall be provided with cable gland and lugs for the size and type of power and control cable of respective motor.



**KAHALGAON STPS (R&M) STAGE-I  
(4x210MW)**

**TECHNICAL SPECIFICATION**

**SPECIFICATION No: PE-TS-455-571-15000A-A002**

**SECTION : I**

**SUB-SECTION : C 1**

**REV. 00**

- 27) All electrical equipment shall be suitable for the power supply fault levels and other climatic conditions indicated in project information / synopsis / specifications enclosed.
- 28) The bidder's proposal shall be for equipment in accordance with the tech. Specification.
- 29) The bidder shall furnish complete tech. Particulars in data sheet and schedules as specified elsewhere in the specification during detail engineering
- 30) All openings required in brick wall for installing the axial supply and exhaust fans, propeller fans, duct opening, louvers and damper openings etc shall be done by BHEL as per opening sizes specified in technical specification. Any opening requirement on account of change in size of equipment over and above the opening size indicated as per opening sizes specified in technical specification, same shall be done by vendor along with finishing of opening and painting as per finished wall. Grouting of fans along with anchor fasteners shall be done by vendor. The openings shall be finished properly. In case openings are done once the wall have been painted, repainting, to match with the existing wall paint shall also be done by the vendor. Sealing of duct opening, grouting of foundation / foundation bolts etc. including special type of grouting like GPX2 etc. are in the scope of Ventilation system vendor.
- 31) All codes and standards shall be as per contract specifications

**7. EXCLUSIONS**

Items of works listed below are excluded from scope of the HVAC system supplier.

- a) False ceiling, drop ceiling.
- b) Slab cut out for running ducts, pipes, cables, grilles/dampers. Underground masonry trenches and masonry risers. However minor civil work like making opening to suit / finishing of opening, sealing of duct opening, grouting of foundation bolts including special type of grouting like GPX2 etc. are in the scope of HVAC system vendor.
- c) Provision of drain traps / points,
- d) For Electrical scope, refer Electrical scope matrix sheet.

**8. CODES AND STANDARDS**

Design, manufacture, inspection and testing of the equipment covered by the specification shall unless otherwise specified conform to the latest edition of the standards and codes including all addenda mentioned below:

IS-659: Safety code for air-conditioning

IS-660: Safety code for mechanical refrigeration

ASHRAE-23: Standard method of testing and rating [67 Standards] air conditioner.

ARI-450-6: Standards for water cooled refrigerant Condenser.

ASME Sec. VII: Unfired pressure vessels



**KAHALGAON STPS (R&M) STAGE-I  
(4x210MW)**

**TECHNICAL SPECIFICATION**

**SPECIFICATION No: PE-TS-455-571-  
15000A-A002**

**SECTION : I**

**SUB-SECTION : C 1**

**REV. 00**

IS-4503: Shell and tube type heat exchanger.  
ASHRAE 22-72: Method of testing for rating water cooled refrigerant condenser.  
ASHRAE-15-2007: Safe Standard for Refrigeration System  
ASHRAE-30-1995: Method of testing liquid chilling packages  
ANSI-8-31.5: Refrigeration piping.  
ANSI-8-9.: Safety code for mechanical refrigeration.  
AR1-410 : Standard for air cooling and air heating coils.  
AR1-210: Standard for unitary air conditioning equipment.  
IS-3588: Specification for electrical axial flow fans.  
AMCA-210: Methods of performance test for fans.  
BS-2831: Methods of test for air filters used in AC and general ventilation.  
IS-4671: Expanded polystyrene for thermal insulation purpose.  
IS-702: Industrial bitumen  
IS-1239: Heavy class Pipes for sizes up to 150 mm dia.  
IS-8188: For Water conditioning  
IS-325: 3 phase induction motors  
IS-4029: Guide line for testing 3 phase induction motor  
IS-210: Specification grey iron casting  
IS-2062: Structural steel  
AMCA - Bulletin: Standard code of testing centrifugal and axial No. 210 flow fans  
IS-2825: Code of practice for welding mild steel  
IS-2676: Dimensions for wrought aluminium and aluminium alloy sheets and strips.  
ASHRAE Code: For various filter  
ASHRAE-62-2004: Ventilation rates  
IS-655: Specification for metal air ducts  
Pump design and testing should correspond to the procedure mentioned in IS-1520



**KAHALGAON STPS (R&M) STAGE-I  
(4X210MW)  
TECHNICAL SPECIFICATION  
CUSTOMER SPECIFICATION**

**SPECIFICATION No: PE-TS-455-571- 15000A-A002**

**SECTION : I**

**SUB-SECTION : C-2**

**REV. 00**

**SECTION: I  
SUB-SECTION: C-2  
CUSTOMER SPECIFICATION**

CLAUSE NO.	TECHNICAL REQUIREMENTS												
	<table border="1"> <thead> <tr> <th data-bbox="440 289 743 338">Clause No.</th> <th data-bbox="743 289 1411 338">Description</th> </tr> </thead> <tbody> <tr> <td data-bbox="440 338 743 394">1.00.00</td> <td data-bbox="743 338 1411 394">General</td> </tr> <tr> <td data-bbox="440 394 743 451">2.00.00</td> <td data-bbox="743 394 1411 451">Design Philosophy</td> </tr> <tr> <td data-bbox="440 451 743 508">3.00.00</td> <td data-bbox="743 451 1411 508">Equipment Description – Air Conditioning System</td> </tr> <tr> <td data-bbox="440 508 743 564">4.00.00</td> <td data-bbox="743 508 1411 564">Balance Equipment Specification</td> </tr> </tbody> </table>	Clause No.	Description	1.00.00	General	2.00.00	Design Philosophy	3.00.00	Equipment Description – Air Conditioning System	4.00.00	Balance Equipment Specification		
Clause No.	Description												
1.00.00	General												
2.00.00	Design Philosophy												
3.00.00	Equipment Description – Air Conditioning System												
4.00.00	Balance Equipment Specification												
KAHALGAON SUPER THERMAL POWER STATION , STAGE-I (4x210 MW)	BIDDING DOC. NO.: CS-4210-104A(R&M)--2	TECHNICAL SPECIFICATION FOR RENOVATION & RETROFITTING OF ESP	PART – B SUB-SECTION-I-M3 Air Conditioning System	Page 1 of 19									

CLAUSE NO.	TECHNICAL REQUIREMENTS																
1.00.00	<b>GENERAL</b>																
1.01.00	<p>Complete air conditioning system and equipment shall be designed as per the Design Philosophy &amp; Equipment specification elaborated below. Sizing calculations for all the equipment shall be submitted for approval of owner during the design phase.</p> <p>The Design, Engineering, Supply, Construction, Erection, and Testing &amp; Commissioning of all the equipment &amp; works listed here shall be on the basis of single point responsibility in bidder's scope of work for satisfactory completion of the system in all respect.</p>																
2.00.00	<p><b>DESIGN PHILOSOPHY</b></p> <p>1. Design ambient conditions for all air conditioning system shall be as indicated below:</p> <table border="1" data-bbox="617 777 1347 1018"> <thead> <tr> <th>Season</th> <th>Dry Bulb Temp. (Deg. C)</th> <th>Wet Bulb Temp. (Deg. C)</th> </tr> </thead> <tbody> <tr> <td>Summer</td> <td>43.0</td> <td>27.5</td> </tr> <tr> <td>Monsoon</td> <td>38.0</td> <td>29.5</td> </tr> <tr> <td>Winter</td> <td>7.0</td> <td>5.8</td> </tr> </tbody> </table> <p>2. All equipment of Air Conditioning system shall be designed for continuous duty.</p> <p>3. Air conditioned areas shall be maintained at 24 deg. C <math>\pm</math> (plus or minus) 1 deg. C and relative humidity of 50% <math>\pm</math> (plus or minus) 5%.</p> <p>4. The fresh air quantity fresh air shall be minimum 1.5 air changes per hour. Fresh air fan capacity shall be minimum 10% of the total CMH value of working indoor units.</p> <p>5. Lighting load shall be 2 Watts/Sq. feet.</p> <p>6. The occupancy shall be minimum one person per 25 Sq.M (Minimum).</p> <p>7. In Air conditioning system the return air shall be through ducts and use of plenum space for return air shall be avoided.</p> <p>8. The supply and return air ducts shall be provided with automatic (motorized) fire dampers (of 90 minutes fire rating) at locations where ducts pass through walls &amp; floors. Operation of these dampers shall be interlocked with the fire alarm system and shall also be possible to operate manually from the remote control panel. Required electrical contacts in control panel of A/C plant and further wiring upto fire alarm panels shall be done by Bidder. Closure of fire dampers shall raise an alarm in the system.</p> <p>9. Coil face area of Air Handling units shall be designed considering a face velocity of not more than 2.5 m/sec. Air distribution system shall be sized to have a</p>				Season	Dry Bulb Temp. (Deg. C)	Wet Bulb Temp. (Deg. C)	Summer	43.0	27.5	Monsoon	38.0	29.5	Winter	7.0	5.8	
Season	Dry Bulb Temp. (Deg. C)	Wet Bulb Temp. (Deg. C)															
Summer	43.0	27.5															
Monsoon	38.0	29.5															
Winter	7.0	5.8															
KAHALGAON SUPER THERMAL POWER STATION , STAGE-I (4x210 MW)	BIDDING DOC. NO.: CS-4210-104A(R&M)-2	TECHNICAL SPECIFICATION FOR RENOVATION & RETROFITTING OF ESP	PART – B SUB-SECTION-I-M3 Air Conditioning System	Page 2 of 19													

CLAUSE NO.	<b>TECHNICAL REQUIREMENTS</b> 			
	<p>constant frictional drop along its length and velocity through ducts shall not exceed 7.6 m/sec.</p> <p>10. Requirement of Underdeck Insulation (for A/C area)</p> <p>Underdeck insulation of 50 mm nominal thickness of glass wool (32 Kg/cu.m) or rock wool (48 Kg/cu.m) shall be provided if</p> <ul style="list-style-type: none"> <li>i) Non A/C area is located just above the A/C area. In this case, underdeck insulation shall be provided underneath of the ceiling of A/C area.</li> <li>ii) Non A/C area is located just below the A/C area. In this case, underdeck insulation shall be provided underneath of the ceiling of Non A/C area.</li> <li>iii) Underneath the ceiling of AHU room located below the A/C area or in case AHU room is exposed to atmosphere.</li> </ul> <p>11. A minimum design margin of ten (10) % shall be considered in design of A/C Plant Capacity.</p> <p>12. Where A/C load is of the order of 25-60 TR, Direct Expansion (D-X) type Condensing unit shall be provided depending on the availability of space/ layout etc. For areas, where A/C load is of the order of 15-25TR, ductable split/package A/C shall be provided. Smaller areas which are away from the D-X type Condensing unit which may require air conditioning upto 15 TR rating shall be served with Hi-wall Split/Cassette air conditioner units of suitable for industrial uses as per requirement.</p> <p>13. Split air conditioner shall conform to minimum three (3) star (*****) rating of latest version of Bureau of Energy Efficiency (BEE) HVAC code issued by Ministry of Power, Govt. of India.</p> <p>14. Refrigerant suction, discharge/hot gas lines &amp; liquid lines shall be sized such that the total pressure drop is equivalent to not more than 1.1 deg C in saturation temperature of refrigerants. However, refrigerant velocity shall not be greater than 0.5 m/sec in liquid line.</p> <p>15. Noise level within the air conditional space shall be restricted to 35-45 NC level with suitable acoustic attenuation/ duct silencers/ acoustic insulation, etc.</p> <p>16. Vibration isolator pads shall be provided with isolation efficiency of minimum 85%.</p>			
<b>3.00.00</b>	<b>EQUIPMENT DESCRIPTION – AIR CONDITIONING SYSTEM</b>			
3.01.00	<p><b>Condensing Unit (Air-Cooled/Water cooled D-X type) (if applicable)</b></p> <p><b>Condensing unit</b></p> <p>Type : Air cooled scroll type</p>			
KAHALGAON SUPER THERMAL POWER STATION , STAGE-I (4x210 MW)	BIDDING DOC. NO.: CS-4210-104A(R&M)--2	TECHNICAL SPECIFICATION FOR RENOVATION & RETROFITTING OF ESP	PART – B SUB-SECTION-I-M3 Air Conditioning System	Page 3 of 19

CLAUSE NO.	TECHNICAL REQUIREMENTS			
	Vibration isolators : Steel spring / Neoprene rubber cushy foot type with isolation efficiency not less than 85%.			
	<b>Compressor</b>			
	Type : The Compressor shall be scroll, serviceable, either hermetic type or semi-hermetic type with automatic capacity control (minimum 3 steps).			
	Type of drive : Motor driven, direct or through V-belt.			
	Refrigerant : The refrigerant shall be R-134a/ R-410A/R-407C or any other environment friendly refrigerant.			
	Accessories : High/Low pressure cutouts, oil pressure switches, relief valves, pressure gauges at each stage, lube oil and control oil pressure gauges, suction & discharge stop valves, Muffler, Crank case heaters, oil filters, magnetic oil separators, temperature indicators for lube oil/heaters, oil level indicators, safety thermostat for crank case heater, vibration isolators, etc.			
	Motor Rating : 10% more than the power required by the compressor at 50 deg C design ambient temperature.			
	Capacity : Minimum capacity shall be suitable for the identified/selected at evaporating temperature and condensing temperature and shall be indicated.			
3.02.00	<b>Air Handling Unit (AHU)</b>			
3.02.01	Each AHU shall consist of casing, fan impeller section, cooling coil section, damper section, steel frame with anti vibration mountings (AVMs) having minimum 85% vibration dampening efficiency and flame retardant, water proof neoprene impregnated flexible connection on fan discharge. Isolation dampers at the suction and discharge of each AHU shall be provided, in case return air duct is directly connected to AHU. However, in case AHU room is used for return air, isolation dampers are required to be provided only at AHU discharge of each AHU. Pre-filter at the suction and fine (micro-vee type) and at the discharge of each individual AHU, and heater section in the common discharge of AHUs shall be provided.			
3.02.02	The casing of AHUs shall be of double skin construction. Double skin sandwich panels (inside and outside) shall be fabricated using minimum 0.63 mm (24g) galvanized steel sheet (thickness of galvanization as per manufacturer's standard) , with 25mm thick polyurethane foam insulation of minimum 38 Kg/Cum density in between. Suitable reinforcements shall be provided to give structural strength to prevent any deformation/buckling.			
3.02.03	Sloping condensate drain pan shall be made of minimum 1.2 mm thick Stainless Sheet Steel. It shall be isolated from bottom floor panel through 25mm thick heavy duty treated for Fire (TF) quality expanded polystyrene or polyurethane foam. Drain pan shall extend beyond the coil.			
KAHALGAON SUPER THERMAL POWER STATION , STAGE-I (4x210 MW)	BIDDING DOC. NO.: CS-4210-104A(R&M)-2	TECHNICAL SPECIFICATION FOR RENOVATION & RETROFITTING OF ESP	PART – B SUB-SECTION-I-M3 Air Conditioning System	Page 4 of 19

CLAUSE NO.	TECHNICAL REQUIREMENTS			
3.02.04	Cooling coil (min. 4 row deep) shall be made of seamless copper tubes with aluminium fins firmly bonded to copper tubes and shall be provided with suitable drains and vents connections.			
3.02.05	All filter plenum shall be provided with a walking platform inside the plenum chamber for filter cleaning purpose. Inspection door shall be provided at the plenum chamber and a removable type ladder shall be attached to plenum.			
3.02.06	<p><b>Centrifugal fan for AHU</b></p> <p>a) Fan Type : Double Width Double Inlet (DWDI) Centrifugal Type</p> <p>b) Fan impeller : Backward curved blades</p> <p>c) Casing material : GI /Mild steel with minimum thickness of 3 mm.</p> <p>d) Impeller material : Carbon steel</p> <p>e) Shaft : EN 8 Steel</p> <p>f) Fan bearings : Self aligning type, permanently lubricated, heavy duty with a design life of 10,000 operating hours.</p> <p>g) Critical speed : First critical speed of rotating assembly shall be at least 25% above the operating speed.</p> <p>h) Drive : Motor driven with removable belt guard.</p>			
3.04.00	<p><b>Pan Humidifier:</b></p> <p>Pan humidifier shall be made of 22 gauge SS 304 tank, duly insulated with 25 mm thick resin bonded fiber glass insulation (min. 24 Kg/m<sup>3</sup> density) with 0.5 mm GSS cladding. The humidifier shall be complete with stainless steel immersion heaters, safety thermostat, float valve with stainless steel ball, sight glass, overflow and drain connections, steam outlet nozzle and float switch. Step controller shall be provided for switching on / off heater banks as per system requirement.</p>			
3.05.00	<b>HI-WALL SPLIT/CASSETTE/ AIR-CONDITIONERS</b>			
3.05.01	<p>Hi-wall Split/cassette air conditioners shall in general consist of the following:</p> <p>i) Casing</p> <p>ii) Hermetically sealed rotary/scroll Compressor</p> <p>iii) Condenser and condenser cooling fan</p>			
KAHALGAON SUPER THERMAL POWER STATION , STAGE-I (4x210 MW)	BIDDING DOC. NO.: CS-4210-104A(R&M)-2	TECHNICAL SPECIFICATION FOR RENOVATION & RETROFITTING OF ESP	PART – B SUB-SECTION-I-M3 Air Conditioning System	Page 5 of 19

CLAUSE NO.	TECHNICAL REQUIREMENTS			
<p>3.05.02</p> <p>3.06.00</p>	<div style="text-align: right; border: 1px solid black; padding: 2px; width: fit-content; margin-bottom: 10px;">  </div> <p>iv) Evaporator along with fan</p> <p>v) Cooling coil</p> <p>vi) Filters</p> <p>vii) Piping, valves, refrigerant strainer, etc.</p> <p>viii) Controls, instruments, control panel/starter panels.</p> <p>ix) Vibration isolator pads, etc as required.</p> <p>x) The refrigerant shall be R-407C/ R-134a/ R-410A or any other environment friendly refrigerant</p> <p>Indoor unit of Ceiling Mounted Cassette Type Unit (Multi Flow Type):</p> <p>The housing of the unit shall be powder coated galvanized steel. All the indoor units regardless of their difference in capacity should have same decorative panel size for harmonious aesthetic point of view.</p> <p>Unit shall have four way supply air grills on sides and return air grill in center.</p> <p>Each unit shall have high lift drain pump and very low operating sound.</p> <p><b>Packaged Air Conditioner:</b></p> <p>PAC units shall be factory tested and assembled self contained units complete with refrigerant compressor, coils, fans, insulation and wiring. Various parts of PAC units wherever required shall be insulated with expanded polyethylene conforming to IS:4671. The PAC unit shall comprise of an evaporator (indoor air) blower section and an air cooled condenser (outdoor air) section. Heavy gauge steel cabinet finished with paint of approved colour, shall be used to house components of PAC. The evaporator and condenser coils shall be arranged for direct expansion cooling and shall be formed of aluminum fins mechanically bonded to seamless copper tubes and electrically tinned. The inter-connecting refrigerant circuits shall comprise of hermetically sealed scroll compressor and motor with all necessary isolation valves, with adjustable set point, sight glass, copper tubing and pipeline ancillaries. The condenser coils shall be air cooled by propeller type fans complete with safety guards. The condensing coils The evaporator air blower(s) shall be centrifugal forward curved type belt driven by individual motor(s) and suitable for the external static pressure. The fan assembly shall be isolated from the casing by anti-vibration mounts. The fan/motor drive shall be capable of capacity adjustment by pulley changes within +15% of design duty shall be suitably arranged to avoid radiant heat pick-up from solar sources. Condenser capacity control shall be provided by means of fans and 'head pressure' sensing. High efficiency filters shall be provided in the main supply air duct before existing discharge duct.</p> <p>A separate cubicle shall be provided within the overall casing to house the thermostatic controls, which shall be electric/electronic solid state, prewired and tested. The refrigerant system shall be protected by pressure limiting devices,</p>			
KAHALGAON SUPER THERMAL POWER STATION , STAGE-I (4x210 MW)	BIDDING DOC. NO.: CS-4210-104A(R&M)-2	TECHNICAL SPECIFICATION FOR RENOVATION & RETROFITTING OF ESP	PART – B SUB-SECTION-I-M3 Air Conditioning System	Page 6 of 19

CLAUSE NO.	TECHNICAL REQUIREMENTS			
<p>4.00.00</p> <p>4.01.00</p> <p>4.02.00</p>	<div style="text-align: right; border: 1px solid black; padding: 2px; width: fit-content; margin-bottom: 10px;">  </div> <p>electric and thermal overloads and unloading facilities to provide the required control range tolerances. A low voltage room thermostat or RTD based temperature sensing device shall be provided for wall mounting. The casing shall be fitted with all necessary coil drains and service connections/ entries. PAC units shall be selected manually and be ON/OFF switched. The units shall be fully packaged and incorporate integral room air sensing control thermostats and manufacturers work fitted safety interlocks. All controls shall be prewired to unit mounted control/power terminal boxes.</p> <p><b>BALANCE EQUIPMENT SPECIFICATION</b></p> <p><b>Material of Construction for Piping &amp; Fittings</b></p> <p>a) Refrigerant piping : Seamless steel tubes conforming heavy grade IS:1239 or copper tubes as per IS:2501 (copper material as per IS:191 hard copper grade).</p> <p>b) Drain piping : Same as (a) above &amp; galvanized as per IS:4736.</p> <p>c) Fittings</p> <ol style="list-style-type: none"> <li>1) The steel fittings shall conform to ASTM A234 Gr. WPB and dimensional standard to ANSI B 16.9/ANSI B16.11 / equivalent for sizes 65 NB and above.</li> <li>2) For sizes 50 NB and below, the material shall conform to ASTM A-105.</li> <li>3) All steel flanges shall be of slip on type and shall conform to ANSI B 16.5</li> <li>4) Fittings, flanges and pipe joints of refrigerant piping shall conform to ANSI B31.5.</li> </ol> <p><b>VALVES</b></p> <ol style="list-style-type: none"> <li>i. Valves shall have full sizes port and suitable for horizontal and as well as vertical installation.</li> <li>ii. Valves for regulating duty shall be of globe type suitable for controlling throughout its lift.</li> <li>iii. All safety /relief valves shall be so constructed that the failure of any part does not obstruct the free discharge.</li> <li>iv. Valves shall be furnished with back seating arrangement for repacking while working under full working pressure.</li> <li>v. All valves shall be supplied with companion flanges, nut, bolts &amp; washers, etc.</li> <li>vi. The refrigerant line valves shall have steel or brass body with TEFLON gland packing. The construction of disc shall be either globe or angle type. The valve seat shall have white metal lining or equivalent.</li> </ol>			
KAHALGAON SUPER THERMAL POWER STATION , STAGE-I (4x210 MW)	BIDDING DOC. NO.: CS-4210-104A(R&M)-2	TECHNICAL SPECIFICATION FOR RENOVATION & RETROFITTING OF ESP	PART – B SUB-SECTION-I-M3 Air Conditioning System	Page 7 of 19

CLAUSE NO.	TECHNICAL REQUIREMENTS			
4.03.00	<p><b>Balancing / Controller Valves:</b></p> <p>The valves of sizes 32 mm to 65 mm dia shall be of gun metal / cast iron construction with screwed ends. Whereas valves of sizes 75 mm and above shall be of cast iron construction with internal parts of SS 410 and EPDM / nitrile seat with flanged ends.</p>			
4.03.00	<p><b>AIR FILTERS</b></p>			
4.03.01	<p><b>Pre Filter</b></p> <ol style="list-style-type: none"> <li>1) Type : Flange / Cassette</li> <li>2) Pre-filter shall contain washable non-woven synthetic fiber or High density Polyethylene (HDPE) media having 18G GSS / 16G Al alloy frame. The filter media shall be supported with HDPE mesh on air inlet side &amp; Aluminium expanded metal on exit side or G.I. wire mesh on both sides.</li> <li>3) <b>Other requirements : (as applicable)</b> <ol style="list-style-type: none"> <li>a) Suitable aluminium spacers be provided for uniform air flow;</li> <li>b) Casing shall be provided with neoprene sponge rubber sealing.</li> <li>c) Capable of being cleaned by water flushing.</li> <li>d) Density of filter medium shall increase in the direction of air flow in case of metallic filter.</li> <li>e) Filter media shall be fire retardant and resistant to moisture, fungi, bacteria &amp; frost.</li> </ol> </li> <li>4) <b>Efficiency :</b> Average arresstance of 65 - 80 % when tested in accordance with BS:6540/ASHRAE – 52 – 76 / EN-779.</li> <li>5) Minimum thickness : 50 mm</li> <li>6) Face Velocity : Not more than 2.5 m/sec.</li> <li>7) Pressure drop : Initial pressure drop - Not to exceed 5.0 mm WC at rated flow. Final pressure drop - Upto 7.5 mm WC.</li> <li>8) Location : a) At the suction of each AHUs b) At the suction of each Fresh air fan</li> </ol>			
4.03.02	<p><b>Fine Filters (Microvee type)</b></p> <ol style="list-style-type: none"> <li>1) Type : Flange / Cassette</li> </ol>			
KAHALGAON SUPER THERMAL POWER STATION , STAGE-I (4x210 MW)	BIDDING DOC. NO.: CS-4210-104A(R&M)-2	TECHNICAL SPECIFICATION FOR RENOVATION & RETROFITTING OF ESP	PART – B SUB-SECTION-I-M3 Air Conditioning System	Page 8 of 19

CLAUSE NO.	TECHNICAL REQUIREMENTS																
	<p>2) Fine filter shall contain washable non-woven synthetic fibre or High density Polyethylene (HDPE) media having 18G GSS / 16G Al alloy frame. The filter media shall be supported with HDPE mesh on air inlet side &amp; Aluminium expanded metal on exit side or G.I. wire mesh on both sides.</p> <p>3) Other requirements : a) A neoprene sponge rubber sealing shall be provided on either face of the filter frame. b) Capable of being cleaned by air or water flushing. c) Filter media shall be fire retardant and resistant to moisture, fungi, bacteria &amp; frost.</p> <p>4) Efficiency : Average arrestance &gt; 90% when tested in accordance with BS:6540/ASHRAE-52-76 / EN-779.</p> <p>5) Minimum thickness : 150 mm or 300 mm.</p> <p>6) Face Velocity : Not more than 1.2 m/sec for 150 mm and not more than 2.4 m/sec. for 300 mm.</p> <p>7) Pressure drop : Initial pressure drop - Not to exceed 10 mm WC at rated flow ; Final pressure drop-Up to 25 mm WC.</p> <p>8) Location : i) At the discharge of each individual AHU. ii) At the discharge of each Fresh air fan.</p>																
4.04.00	<b>LOW PRESSURE AIR DISTRIBUTION SYSTEM</b>																
4.04.01	Material of air distribution system shall be through galvanized steel sheet and galvanizing shall be of 275 gms/sq.m. (total coating on both sides) both for site fabricated and factory fabricated ducts.																
4.04.02	<p><b>Thickness of rectangular ducts shall be as follows:</b></p> <table border="1" data-bbox="456 1297 1373 1539"> <thead> <tr> <th>Larger Dimension of duct (mm)</th> <th>Thickness of GI sheet(mm)</th> <th>Thickness of Aluminium sheet (mm)</th> </tr> </thead> <tbody> <tr> <td>up to 750 mm</td> <td>0.63 (24 G)</td> <td>0.80</td> </tr> <tr> <td>751 to 1500</td> <td>0.80 (22 G)</td> <td>1.00</td> </tr> <tr> <td>1501 to 2250</td> <td>1.00 (20 G)</td> <td>1.50</td> </tr> <tr> <td>2251 &amp; above</td> <td>1.25 (18 G)</td> <td>1.80</td> </tr> </tbody> </table>	Larger Dimension of duct (mm)	Thickness of GI sheet(mm)	Thickness of Aluminium sheet (mm)	up to 750 mm	0.63 (24 G)	0.80	751 to 1500	0.80 (22 G)	1.00	1501 to 2250	1.00 (20 G)	1.50	2251 & above	1.25 (18 G)	1.80	
Larger Dimension of duct (mm)	Thickness of GI sheet(mm)	Thickness of Aluminium sheet (mm)															
up to 750 mm	0.63 (24 G)	0.80															
751 to 1500	0.80 (22 G)	1.00															
1501 to 2250	1.00 (20 G)	1.50															
2251 & above	1.25 (18 G)	1.80															
4.04.03	<p><b>Duct Fabrication and Supports:</b></p> <p>a) Duct fabrication shall be as per the latest relevant BIS/SMACNA standard.</p> <p>b) Ducts for A/C system may be <b>site fabricated or factory fabricated</b>.</p>																
KAHALGAON SUPER THERMAL POWER STATION, STAGE-I (4x210 MW)	BIDDING DOC. NO.: CS-4210-104A(R&M)-2	TECHNICAL SPECIFICATION FOR RENOVATION & RETROFITTING OF ESP	PART – B SUB-SECTION-I-M3 Air Conditioning System	Page 9 of 19													

CLAUSE NO.	TECHNICAL REQUIREMENTS			
	<div style="text-align: right; border: 1px solid black; padding: 2px; width: fit-content; margin-bottom: 10px;">  </div> <p>c) The ducts routed inside the buildings with larger side greater than 2250 mm shall be supported by 16mm MS rods and 50x50x3 mm MS double Angles while those below 2250 mm shall be supported by 10mm MS Rods and 40x40x3 MS angles. The duct supports shall be at a distance of not more than 2000 mm for A/C system. The MS rods for these ducts routed inside the building shall be hung from the existing floor beams/wall beams/roof beams/columns with provision of necessary auxiliary or special steel members or by hooks or can be provided by dash fasteners fixed to the ceiling slab. No supports shall be taken from horizontal/vertical bracings of the structures. All items of duct support including MS rods, MS angles and double angles, auxiliary or special steel members, hooks, dash fasteners coach screws and all other supporting material required shall be provided by the bidder. Where ever ducts are running outside the building and or at locations where it is not possible to support the ducts from ceiling/floor due to non-availability of the same, the base steel frame/truss work and other auxiliary steel members, hooks, rods, etc. for supporting the duct work shall also be provided by the Bidder.</p> <p>d) Where the sheet metal duct connects to the intake or discharge of fan units a flexible connection of fire retarding, at least 150 mm width shall be provided of closely woven, rubber impregnated double layer asbestos/canvas or neoprene coated fibre glass.</p> <p>e) All curves, bends, off-sets and other transformations shall be made for easy and noiseless flow of air. The throat of every branch duct shall be sized to have the same velocity as in the main duct to which the branch duct is connected.</p> <p>f) Wherever duct passes through a wall, the opening between masonry and duct work shall be neatly caulked or sealed to prevent movement of air from one space to the adjoining space.</p> <p>g) Wherever pipe hangers or rods pass through the ducts, light and streamline easement around the same shall be provided to maintain smooth flow of air.</p> <p>h) Access doors shall be provided in the duct work or casing on the both sides of the equipment to be serviced. All access doors shall be of adequate size and shall be lined with substantial felt edging to prevent air leakage. Access doors shall be of built up construction, structurally strong and each shall have at least two hinges. Access doors shall have two rust proof window sash of approved type. All doors shall be set so as to flush with insulation or plaster finish on the duct.</p> <p>4.04.04 Splitters and dampers shall be provided for equipment/area isolation and for proportional volume control of system. The same shall be minimum 16 gauge GS sheet of quadrant type with suitable locking device, mounted outside of duct in accessible position.</p> <p>4.04.05 <b>Factory fabricated ducts:</b></p> <p>i) All ducting shall be fabricated of LFQ (Lock Forming Quality) grade prime G.I.</p>			
KAHALGAON SUPER THERMAL POWER STATION , STAGE-I (4x210 MW)	BIDDING DOC. NO.: CS-4210-104A(R&M)-2	TECHNICAL SPECIFICATION FOR RENOVATION & RETROFITTING OF ESP	PART – B SUB-SECTION-I-M3 Air Conditioning System	Page 10 of 19

CLAUSE NO.	TECHNICAL REQUIREMENTS																			
<p>ii) Factory fabricated ducts shall have the thickness of the sheet as follows:</p> <table border="1" data-bbox="613 331 1263 512"> <thead> <tr> <th>Sl.No.</th> <th>Size of Duct</th> <th>Sheet Thickness</th> </tr> </thead> <tbody> <tr> <td>i)</td> <td>upto 750 mm</td> <td>0.63 mm</td> </tr> <tr> <td>ii)</td> <td>751 mm to 1500 mm</td> <td>0.80 mm</td> </tr> <tr> <td>iii)</td> <td>1501 mm to 2250 mm</td> <td>1.00 mm</td> </tr> <tr> <td>iv)</td> <td>2251 mm and above</td> <td>1.25 mm</td> </tr> </tbody> </table> <p>iii) Unless otherwise specified here, the construction, erection, testing and performance of the ducting system shall conform to the SMACNA-1995 standards ("HVAC Duct Construction Standards-Metal and Flexible-Second Edition-1995" SMACNA)</p> <p><b>4.05.00 Diffusers, Grills &amp; Dampers :</b></p> <p>4.05.01 Supply air diffusers/grills with factory fitted volume control dampers be provided for all air-conditioned areas.</p> <p>4.05.02 Return air diffusers of air-conditioned areas shall be without volume control dampers.</p> <p>4.05.03 The diffusers/grills shall be of extruded Aluminum of minimum 2 mm thick with powder coating. The colour of powder coating shall be as per the interior décor.</p> <p>4.05.04 Supply air grills shall be of double deflection type and return air grills shall be of single deflection type.</p> <p>4.05.05 All volume control (VC) damper shall be operated by a key from the front of the grills/diffusers and shall be of GI sheet.</p> <p>4.05.06 The thickness of VC dampers shall be of minimum 20 gauge and thickness of louvers shall be of minimum 22 gauge.</p> <p>4.05.07 Suitable vanes shall be provided in the duct collar to have uniform and proper air distribution. Bank of Baffles wherever required shall also be provided.</p> <p>4.05.08 Fire dampers shall be motor operated type and shall have fire rating of minimum 90 minutes.</p> <p>4.05.09 All plenum chambers of connections to fans, dampers etc. shall be constructed in 18 gauge GS sheet and supported on MS angle frames.</p> <p>4.05.10 All ducting surfaces coming in contact with corrosive fumes or gases shall be painted with three coats of epoxy paint over a coat of suitable primer.</p> <p>4.05.11 Thermal and Acoustic Insulation.</p> <p><b>4.06.00 A) Application with Mineral Wool</b></p> <p>1. All surfaces to be insulated both thermally and acoustically shall be thoroughly cleaned, dried and an adhesive (CPRX compound of Shalimar Tar Products or Equivalent) be applied @ 1.5 Kg /Sq.m on the surface.</p>	Sl.No.	Size of Duct	Sheet Thickness	i)	upto 750 mm	0.63 mm	ii)	751 mm to 1500 mm	0.80 mm	iii)	1501 mm to 2250 mm	1.00 mm	iv)	2251 mm and above	1.25 mm					
	Sl.No.	Size of Duct	Sheet Thickness																	
	i)	upto 750 mm	0.63 mm																	
	ii)	751 mm to 1500 mm	0.80 mm																	
	iii)	1501 mm to 2250 mm	1.00 mm																	
	iv)	2251 mm and above	1.25 mm																	
	KAHALGAON SUPER THERMAL POWER STATION , STAGE-I (4x210 MW)	BIDDING DOC. NO.: CS-4210-104A(R&M)-2	TECHNICAL SPECIFICATION FOR RENOVATION & RETROFITTING OF ESP	PART – B SUB-SECTION-I-M3 Air Conditioning System	Page 11 of 19															

CLAUSE NO.	TECHNICAL REQUIREMENTS																
4.06.01	<p>2. Insulation material (either expanded polystyrene foam or Glass Wool/ Glass fiber or Equivalent) shall be struck to the surface. All the joints shall be sealed with bitumen.</p> <p>3. Insulation mass to be covered with 500 gauge polythene sheet with 50 mm overlaps and sealing all joints on hot side.</p> <p>4. Insulation Finish of types specified under shall be provided thereafter.</p> <p><b>B) Application with Nitrile Rubber:</b></p> <p>(a) All surfaces to be insulated shall be properly cleaned.</p> <p>(b) A suitable adhesive such as SR 998 or equivalent shall be applied over the surfaces to be insulated and insulation material surfaces.</p> <p>(c) Insulating material shall than be pasted onto the surfaces in a manner to avoid stretching and any air entrapment within.</p> <p>(d) Two layers of Glass Cloth with a suitable adhesive as SR 998 or equivalent shall be then applied over the insulating material to avoid surface weathering.</p> <p><b>C) Application with FR Closed Cell Chemically Cross Linked Polyethylene Material (XLPE)</b></p> <p>(a) All surfaces to be insulated shall be properly cleaned of any dust, grease and moisture.</p> <p>(b) A suitable adhesive, normally, a pressure sensitive acrylic base, such as SR 998/STAR Glue R242 or Neosole AA 900 or equivalent shall be used to paste the insulating material over the cleaned surface.</p> <p>(c) XLPE cut to size for each surface, with overlaps provided for two faces shall be stuck to the surfaces in a manner to avoid air entrapment. The extent of over-lap shall be equivalent to the thickness of the material to be applied. The adhesive is applied on both the surfaces to be insulated and the insulation foam material.</p> <p>(d) Application of the insulating material to surfaces should preferably be carried out at ground level, in a clean dust free area.</p> <p>(e) All joints- lateral &amp; longitudinal, shall be taped with self adhesive aluminium foil tape 75 mm wide. The insulation over the surface shall be then held in position with 12mm wide PVC straps at every 600mm, to provide a neat &amp; clean finish.</p>																
	<b>Type of Insulation &amp; Finish</b>																
<table border="1"> <thead> <tr> <th data-bbox="459 1533 548 1627">Sl. No.</th> <th data-bbox="548 1533 738 1627">Surface</th> <th data-bbox="738 1533 966 1627">Insulation Material</th> <th data-bbox="966 1533 1104 1627">Insulation Form</th> <th data-bbox="1104 1533 1230 1627">Thick (mm)</th> <th data-bbox="1230 1533 1421 1627">Finish (mm)</th> </tr> </thead> <tbody> <tr> <td data-bbox="459 1627 548 1816">1.</td> <td data-bbox="548 1627 738 1816">Supply &amp; return air duct of A/C System</td> <td data-bbox="738 1627 966 1816">Resin bonded glass wool / Rockwool  or</td> <td data-bbox="966 1627 1104 1816">Roll /Slab</td> <td data-bbox="1104 1627 1230 1816">50</td> <td data-bbox="1230 1627 1421 1816">F-3</td> </tr> </tbody> </table>						Sl. No.	Surface	Insulation Material	Insulation Form	Thick (mm)	Finish (mm)	1.	Supply & return air duct of A/C System	Resin bonded glass wool / Rockwool  or	Roll /Slab	50	F-3
Sl. No.	Surface	Insulation Material	Insulation Form	Thick (mm)	Finish (mm)												
1.	Supply & return air duct of A/C System	Resin bonded glass wool / Rockwool  or	Roll /Slab	50	F-3												
KAHALGAON SUPER THERMAL POWER STATION , STAGE-I (4x210 MW)	BIDDING DOC. NO.: CS-4210-104A(R&M)--2	TECHNICAL SPECIFICATION FOR RENOVATION & RETROFITTING OF ESP	PART – B SUB-SECTION-I-M3 Air Conditioning System	Page 12 of 19													

CLAUSE NO.		TECHNICAL REQUIREMENTS				
Sl. No.	Surface	Insulation Material	Insulation Form	Thick (mm)	Finish (mm)	
		Closed Cell Elastomeric Nitrile Rubber  Or FR Closed Cell Chemically Cross Linked Polyethylene (XLPE) with Al foil face	sheet  Roll	19  19	As per manufacturer std.  F-3(a)	
2.	Refrigerant (Suction and liquid lines)	Closed Cell Elastomeric Nitrile Rubber  Or FR Closed Cell Chemically Cross Linked Polyethylene (XLPE)	Tube  Pre-formed tube/roll	19  19	As per manufacturer std.  F-1(a)	
3.	AHU drain pipe	Closed Cell Elastomeric Nitrile Rubber  Or FR Closed Cell Chemically Cross Linked Polyethylene pre formed tubing (XLPE)	Tube  Pre-formed tube	19  19	As per manufacturer std.  F-1(a)	
4.	AHU condensate pan (insulation if required)	Resin Bonded glass wool / rock wool  Or FR Closed Cell Chemically Cross Linked Polyethylene (XLPE) with Al foil	Slab  Sheet	25  15	As per manufacturer std.  F-1(a)	
KAHALGAON SUPER THERMAL POWER STATION, STAGE-I (4x210 MW)		BIDDING DOC. NO.: CS-4210-104A(R&M)--2	TECHNICAL SPECIFICATION FOR RENOVATION & RETROFITTING OF ESP	PART - B SUB-SECTION-I-M3 Air Conditioning System	Page 13 of 19	

CLAUSE NO.	TECHNICAL REQUIREMENTS					
	<b>Sl. No.</b>	<b>Surface</b>	<b>Insulation Material</b>	<b>Insulation Form</b>	<b>Thick (mm)</b>	<b>Finish (mm)</b>
			face			
	5.	Acoustic insulation of duct	Resin bonded Glass wool	Slab	25	As per specifications
	6	Exposed air duct	Resin bonded glass wool / rock wool  Or FR Closed Cell Chemically Cross Linked Polyethylene (XLPE) with Al foil face	Roll  Roll	50  19	F-4  F-4(a)
4.06.02	<b>Specification for insulation shall be as follows: -</b>					
	<b>Insulation Material</b>	<b>Code</b>	<b>Thermal conductivity (w/m/°C)</b>	<b>Density Kg/m<sup>3</sup></b>		
	Resin bonded glass wool / rock wool	IS:8183	0.049 at 50°C	i) 24 (For thermal insulation) ii) 48(For acoustic insulation)		
	Mineral wool pipe section. Min.Gr.2	IS:9842	0.043 at 50°C	Rockwool – 144 Glasswool - 90		
	Closed Cell Elastomeric Nitrile Rubber		0.034 at 20°C	40-60		
	FR Closed Cell Chemically Cross Linked Polyethylene (XLPE)		0.033 at 23° C	33 ± 3		
	Note : Insulation used for HVAC application shall be CFC/HCFC free					
4.06.03	<b>The specification for various finishes shall be as follows:</b>					
	a)	<b>Finish F-1</b>				
		<u>Step-1</u> Wrapping of Poly-Bonded Hessain (PBH – to act as vapour seal)				
KAHALGAON SUPER THERMAL POWER STATION , STAGE-I (4x210 MW)		BIDDING DOC. NO.: CS-4210-104A(R&M)-2	TECHNICAL SPECIFICATION FOR RENOVATION & RETROFITTING OF ESP	PART – B SUB-SECTION-I-M3 Air Conditioning System	Page 14 of 19	

CLAUSE NO.	TECHNICAL REQUIREMENTS			
		<p>on outer surface of insulation with 50 mm overlap stitching and sealing of overlap with synthetic adhesive like CPRX or Equivalent compound.</p> <p><u>Step-2</u> The surface then shall be wrapped with 19 mm mesh 24 SWG GI wire netting, butting all the joints and laced down with 22 SWG lacing wire.</p> <p><u>Step-3</u> Sand cement (4:1) plaster shall be applied in two layers totalling to 12.5 mm thick, the second layer being brought to a smooth finish. A water proofing compound shall be added to the cement before its application.</p>		
aa)		<p><b>Finish F-1(a) (With FR Closed Cell Chemically Cross Linked Polyethylene Material)</b></p>		
		<p>Wrapping of two layers of 7 mil 10x10 mesh glass cloth dipped in suitable adhesive such as SR 998 or equivalent.</p>		
	b)	<p><b>Finish F-2</b></p> <p><u>Step-1</u> Insulation shall be covered with 500g polythene with 50mm overlap and sealing of overlap with synthetic adhesive like CPRX or Equivalent compound.</p> <p><u>Step-2</u> Same as Step-2 of Finish F-1 above.</p> <p><u>Step-3</u> Same as Step-3 of Finish F-1 above.</p>		
	c)	<p><b>Finish F-3</b></p> <p><u>Step-1</u> Same as Step-1 of Finish F-2 above</p> <p><u>Step-2</u> The polythene shall be covered with 30 gauge Aluminium sheet and locking of joints with self-locking screws at a pitch of minimum 100 mm.</p>		
	cc)	<p><b>Finish F-3(a) (With FR Closed Cell Chemically Cross Linked Polyethylene Material)</b></p>		
		<p>Al foil faced XLPE material applied over duct surfaces, shall be covered with 30 gauge aluminium sheet, having tongue-in-groove joints and these are held in position with self drilling self tapping screws (SDST) at a distance of 150mm.</p>		
	d)	<p><b>Finish F-4</b></p> <p><u>Step-1</u> Same as Step-1 of Finish F-1 above.</p> <p><u>Step-2</u> Same as Step-2 of Finish F-1 above.</p> <p><u>Step-3</u> Same as Step-3 of Finish F-1 above.</p> <p><u>Step-4</u> Application of 3 mm thick coat of water proofing compound and wrapped with fibre glass RP tissue followed by final coat of 3 mm thick water proofing compound over the RP tissue.</p>		
KAHALGAON SUPER THERMAL POWER STATION , STAGE-I (4x210 MW)	BIDDING DOC. NO.: CS-4210-104A(R&M)-2	TECHNICAL SPECIFICATION FOR RENOVATION & RETROFITTING OF ESP	PART – B SUB-SECTION-I-M3 Air Conditioning System	Page 15 of 19

CLAUSE NO.	TECHNICAL REQUIREMENTS			
4.06.04		<u>Step-5</u> After the above treatment, 22G Aluminium sheet cladding, properly stitched at all joints shall be provided over the external surface.		
	dd)	<b>Finish F-4(a) (With FR Closed Cell Chemically Cross Linked Polyethylene Material)</b>		
		Application of aluminium sheet 22G cladding to be provided over the XLPE insulating material. Cladding sheet is held in position with SDST screws @ 150 mm C/C over tongue-in-groove joints applied with a felt for sealing joint against water ingress. All sheet joints to be done in a manner to shed water.		
4.06.04	For all inspection covers and hatches on equipment, pump casing, valve bodies and flanges (100 mm and above), insulation shall be applied so as to facilitate removal without minimum damage to the insulation by encasing the insulation in 24 gauge GI box or 22 gauge Aluminium sheet metal boxes which are bolted together around the equipment. However continuity of the vapour seal between the static and removable portions of the insulation is to be maintained.			
4.07.00	<p><b>ACOUSTIC INSULATION</b></p> <p>a) All ducts up to a distance of 5 meters from AHU shall be acoustically lined from inside with 25 mm thick resin bonded glass wool of 48 Kg/Cu.M. density and 30 gauge perforated aluminium sheet having 5 mm dia perforation at 8 to 10 mm centre-to-centre distance. Insulation shall be fixed on wooden frame of 600 x 600 mm dimension.</p> <p>b) Fibre glass tissue sheet shall be applied over the outer surface of insulation before applying perforated aluminium sheet. Application of acoustic insulation shall be inline with the requirements specified above.</p>			
4.08.00	<p><b>FRESH AIR FANS (Axial Fans)</b></p> <p>a) These fans shall have fixed / variable pitch cast aluminum blades of aerofoil design.</p> <p>b) The fan casing shall be of heavy gauge sheet steel construction.</p> <p>c) Necessary rain protection cowl, inlet and outlet cones, bird protection screen, adjustable damper, vibration isolators, back draft dampers etc. shall be provided.</p> <p>d) The speed of the fan shall not exceed 960 rpm for fan with impeller diameter above 450 mm and 1400 rpm for fan with impeller diameter 450 mm or less. However for fans having static pressure of 30 mm WC or above the speed of the fan shall not exceed 1440 rpm for fan with impeller diameter of above 450 mm and 2800 rpm for fan with impeller diameter of 450 mm or less. The first critical speed of rotating assembly shall be atleast 25% above the operating speed.</p> <p>e) All other accessories like supporting structure etc. as required shall be provided.</p>			
KAHALGAON SUPER THERMAL POWER STATION , STAGE-I (4x210 MW)	BIDDING DOC. NO.: CS-4210-104A(R&M)-2	TECHNICAL SPECIFICATION FOR RENOVATION & RETROFITTING OF ESP	PART – B SUB-SECTION-I-M3 Air Conditioning System	Page 16 of 19

CLAUSE NO.	TECHNICAL REQUIREMENTS			
4.09.00	<b>PLANT CONTROL</b>			
4.09.01	Brief scheme of controlling the operation is described below. Detailed description of the control system for safe and efficient operation of the plant shall be elaborated, got approved from employer. The descriptions in the sub-sections of the control & instrument sections shall also be referred to.			
4.09.02	<b>Control Scheme for Air-Conditioning System</b> <ol style="list-style-type: none"> <li>i. Brief scheme of controlling the operation is described below. Detailed description of the control system for safe and efficient operation of the plant shall be elaborated, got approved from employer.</li> <li>ii. The basic function of the system shall be to closely control and monitor temperature and humidity conditions inside the air-conditioned spaces, to optimize / minimize energy consumption by automated operation, to provide remote centralized monitoring &amp; control for various mechanical facilities including sequential start/stop of the whole Air conditioning System.</li> <li>iii. Contractor shall provide microprocessor/PLC/GIU based control system for control and monitoring of air conditioning and ventilation system as per manufacturer's standard practice. Control and monitoring of air conditioning and ventilation system from ESP control system is also acceptable.</li> </ol>			
4.09.03	<b>Air Handling Unit</b> <ol style="list-style-type: none"> <li>a) Humidity sensor and gyserst at located in the return air duct shall actuate the PAN humidifier to obtain the desired degree of humidification.</li> <li>b) Humidity and temp. sensor shall be provided and interlocked in steps with winter heater / re-heater / strip heaters for monsoon and winter re-heating or heating as the case may be.</li> <li>c) Heater banks shall be interlocked with the running of AHU, temperature of return air, humidity of return air and safety thermostat (airstat - located in front of the each heater in the supply air duct)</li> <li>d) AHU shall be started either locally or from the main control room of AC system by means of Remote / Manual selection facility.</li> <li>e) The closure of fire dampers, automatic tripping of AHU fans and fresh air fans shall be interlocked with Fire Detection System.</li> </ol>			
4.09.04	<b>Cassette /Hi-wall Split Air Conditioners</b> <ol style="list-style-type: none"> <li>a) Control and interlocks for these type of units shall be as per manufacturer's standard practice.</li> </ol>			
4.09.05	<b>Miscellaneous Control Requirements</b> <ol style="list-style-type: none"> <li>a) Separate emergency local stop push button shall be provided for each compressor, fans etc. of A/C system.</li> </ol>			
KAHALGAON SUPER THERMAL POWER STATION , STAGE-I (4x210 MW)	BIDDING DOC. NO.. CS-4210-104A(R&M)--2	TECHNICAL SPECIFICATION FOR RENOVATION & RETROFITTING OF ESP	PART – B SUB-SECTION-I-M3 Air Conditioning System	Page 17 of 19

CLAUSE NO.	TECHNICAL REQUIREMENTS			
	<p>b) The fans (both supply and exhaust fans) associated with mechanical ventilation system shall be operated locally.</p> <p>c) All the annunciations related to failure of equipment, tripping of equipment, source of failure / reason due to which the equipment is stopped / tripped, low &amp; high limits of parameters such as level, temperature, pressure drop, pressure etc. shall be provided for each pump, fan, compressor, AHU, air cooled condensing unit, etc.</p> <p>d) Relative humidity and temperature measurement of all control rooms and all major air-conditioned areas shall made be available in ESP control system</p>			
4.10.00	<b>PAINTING:</b>			
4.10.01	All the Equipment shall be protected against external corrosion by providing suitable painting.			
4.10.02	The surfaces of stainless steel, Galvanized steel, Gunmetal, brass, bronze and non-metallic components shall not be applied with any painting. The Contractor shall clean the external surfaces and internal surfaces before Erection by wire brushing and air blowing. The steel surface to be applied with painting shall be thoroughly cleaned before applying painting by brushing, shot blasting, etc. as per the agreed procedure.			
4.10.03	For all the steel surfaces (external) exposed to atmosphere (outdoor installation), one(1) coat of red oxide primer of thickness 30 to 35 microns followed up with three (3) coats of synthetic enamel paint, with 25 microns as thickness of each coat, shall be applied.			
4.10.04	For all the steel surfaces inside the building (indoor installation), One (1) Coat of red oxide primer of thickness 30 to 35 microns followed up with two (2) coats synthetic enamel paint, with 25 microns as thickness of each coat shall be applied.			
4.10.05	For centrifugal fans - Casing shall have hot dip/ spray galvanization ( <b>minimum 60 micron DFT</b> ).			
4.10.06	However, for all parts coming in contact with acid fumes (in Battery rooms), a coat of epoxy resin based zinc phosphate primer of minimum thickness 30 to 35 microns followed up with undercoat of epoxy resin based paint pigmented with Titanium dioxide of minimum thickness of 25 microns shall be applied and a top coat consisting of one coat of epoxy paint of approved shade and colour with glossy finish of minimum thickness of 25 microns.			
4.11.00	<b>CODES &amp; STANDARDS</b>			
4.11.01	The design, manufacture and performance of equipment shall comply with all currently applicable statues, regulations and safety codes in the locality where the equipments are to be installed. Nothing in this specification shall be considered to relieve the bidder of this responsibility.			
4.11.02	Unless otherwise specified, equipment shall conform to the latest applicable Indian or IEC standard. Equipment complying with other authoritative standards such as			
KAHALGAON SUPER THERMAL POWER STATION , STAGE-I (4x210 MW)	BIDDING DOC. NO.: CS-4210-104A(R&M)-2	TECHNICAL SPECIFICATION FOR RENOVATION & RETROFITTING OF ESP	PART – B SUB-SECTION-I-M3 Air Conditioning System	Page 18 of 19

CLAUSE NO.	TECHNICAL REQUIREMENTS			
	<p data-bbox="1279 197 1385 247">एनटीपीसी NTPC</p> <p data-bbox="435 264 1385 323">British, USA, ASHRAE etc. will also be considered if it ensures performance equivalent or superior to Indian Standard.</p>			
KAHALGAON SUPER THERMAL POWER STATION , STAGE-I (4x210 MW)	BIDDING DOC. NO.: CS-4210-104A(R&M)--2	TECHNICAL SPECIFICATION FOR RENOVATION & RETROFITTING OF ESP	PART – B SUB-SECTION-I-M3 Air Conditioning System	Page 19 of 19



**KAHALGAON STPS (R&M) STAGE-I  
(4x210MW)  
HVAC SYSTEM  
TECHNICAL SPECIFICATION  
(ELECTRICAL PORTION)**

**SPECIFICATION No: PE-TS-455-571- 15000A-A002**

**SECTION : I**

**SUB-SECTION : C-3**

**REV. 00**

**SECTION: I**

**SUB-SECTION: C-3**

**TECHNICAL SPECIFICATION (ELECTRICAL PORTION)**



**TECHNICAL SPECIFICATION FOR  
HVAC SYSTEM  
(ELECTRICAL PORTION)**

VOLUME II B  
SECTION-I

PAGE 1 OF 1

**SPECIFIC TECHNICAL REQUIREMENTS: ELECTRICAL**

**1.0 EQUIPMENT & SERVICES TO BE PROVIDED BY BIDDER/ PURCHASER**

- 1.1 Scope for supply, and erection & commissioning of various equipment forming part of electrical system for this package shall be as per Annexure-I to Section -I [Scope of Work (Electrical)].
- 1.2 Make of various equipment/ items in the scope of bidder shall be to approval of owner during detailed engineering stage without any commercial implications.
- 1.3 Bidder shall furnish all AC as well as DC loads required for the system at different voltage levels (eg. 415V AC, 240 V AC, 220 V DC etc.) of all types, such as motor feeders, supply feeders in PEM format along with the offer.
- 1.4 All electrical equipment shall be suitable for the power supplies, fault levels and climatic conditions indicated in project information enclosed with the specification.
- 1.5 All drawings, data sheets, Quality Plan, calculations, test reports, test certificates, etc. shall be submitted during detailed engineering stage as per formats enclosed. The same shall be subject to approval without any commercial implications.
- 1.6 Technical requirements shall be as per specifications listed in Clause 3.1 to 3.5 In case of any discrepancy between NTPC specification and BHEL standard specification, NTPC specification shall prevail.

**2.0 DOCUMENTS TO BE SUBMITTED ALONG WITH BID**

2.1 The electrical specification without any deviation from the technical/quality assurance requirements stipulated shall be deemed to be complied by the bidder in case bidder furnishes the overall compliance of package technical specification in the form of compliance certificate/No deviation certificate.

2.2 No technical submittal such as copies of data sheets, drawings, write-up, quality plans, type test certificates, technical literature, etc, is required during tender stage. Any such submission even if made, shall not be considered as part of offer.

**3.0 LIST OF ENCLOSURES**

- 3.1 Electrical scope between BHEL & vendor.
- 3.2 Technical specification of motors, cables , cabling (NTPC)
- 3.3 Technical specification of AC fuse DBs
- 3.4 Datasheets - C for motors
- 3.5 Quality Assurance/Plan for motors, cables, cabling

## **SUB-SECTION-II-E-02**

### **MOTORS**

CLAUSE NO.	TECHNICAL REQUIREMENTS			
				
	<b>MOTORS</b>			
<b>1.00.00</b>	<b>GENERAL REQUIREMENTS</b>			
1.01.00	For the purpose of design of equipment/systems, an ambient temperature of 50 deg. Centigrade and relative humidity of 95% (at 40 deg C) shall be considered. The equipment shall operate in a highly polluted environment.			
1.02.00	All equipments shall be suitable for rated frequency of 50 Hz with a variation of +3% & -5%, and 10% combined variation of voltage and frequency unless specifically brought out in the specification.			
1.03.00	Contractor shall provide fully compatible electrical system, equipments, accessories and services.			
1.04.00	All the equipment, material and systems shall, in general, conform to the latest edition of relevant National and international Codes & Standards, especially the Indian Statutory Regulations.			
1.05.00	Paint shade shall be as per RAL 5012 (Blue) for indoor and outdoor equipment.			
1.06.00	The responsibility of coordination with electrical agencies and obtaining all necessary clearances for contractors equipment and systems shall be under the contractor scope.			
1.07.00	Degree of Protection			
	Degree of protection for various enclosures as per IS:4691, IEC60034-05 shall be as follows :-			
	i)	Indoor motors	-	IP 54
	ii)	Outdoor motors	-	IP 55
	iii)	Cable box-indoor area	-	IP 54
	iv)	Cable box-Outdoor area	-	IP 55
<b>2.00.00</b>	<b>CODES AND STANDARDS</b>			
	1)	Three phase induction motors	:	IS:325, IEC:60034
	2)	Single phase AC motors	:	IS:996, IEC:60034
	3)	Crane duty motors	:	IS:3177, IEC:60034
	4)	DC motors/generators	:	IS:4722, IEC:60034
	5)	Energy Efficient motors	:	IS 12615, IEC:60034-30
KAHALGAON SUPER THERMAL POWER STATION STAGE-I (4x210 MW)	BIDDING DOC. NO.: CS-4210-104A(R&M)-2	TECHNICAL SPECIFICATION FOR RENOVATION & RETROFITTING OF ESP	PART – B SUB-SECTION II- E-02 MOTORS	Page 1 of 9

CLAUSE NO.	TECHNICAL REQUIREMENTS				
3.00.00	<b>TYPE</b>				
3.01.00	<b>AC Motors:</b> <ol style="list-style-type: none"> <li>a) Squirrel cage induction motor suitable for direct-on-line starting.</li> <li>b) Continuous duty LT motors upto 160 KW Output rating (at 50 deg.C ambient temperature), shall be <b>Premium Efficiency class-IE3</b>, conforming to IS 12615, or IEC:60034-30.</li> <li>c) Crane duty motors shall be slip ring/ squirrel cage Induction motor as per the requirement.</li> </ol>				
3.02.00	DC Motors	Shunt wound.			
4.00.00	<b>RATING</b>				
5.00.00	<b>TEMPERATURE RISE</b>  <b>Air cooled motors</b>  70 deg. C by resistance method for both thermal class 130(B) & 155(F) insulation.  <b>Water cooled</b>  80 deg. C over inlet cooling water temperature mentioned elsewhere, by resistance method for both thermal class 130(B) & 155(F) insulation.				
6.00.00	<b>OPERATIONAL REQUIREMENTS</b>				
6.01.00	<b>Starting Time</b>				
6.01.01	For motors with starting time upto 20 secs. at minimum permissible voltage during starting, the locked rotor withstand time under hot condition at highest voltage limit shall be at least 2.5 secs. more than starting time.				
6.01.02	For motors with starting time more than 20 secs. and upto 45 secs. at minimum permissible voltage during starting, the locked rotor withstand time under hot condition at highest voltage limit shall be at least 5 secs. more than starting time.				
KAHALGAON SUPER THERMAL POWER STATION STAGE-I (4x210 MW)	BIDDING DOC. NO.: CS-4210-104A(R&M)-2	TECHNICAL SPECIFICATION FOR RENOVATION & RETROFITTING OF ESP	PART – B SUB-SECTION II- E-02 MOTORS	Page 2 of 9	

CLAUSE NO.	TECHNICAL REQUIREMENTS			
6.01.03	For motors with starting time more than 45 secs. at minimum permissible voltage during starting, the locked rotor withstand time under hot condition at highest voltage limit shall be more than starting time by at least 10% of the starting time.			
6.01.04	Speed switches mounted on the motor shaft shall be provided in cases where above requirements are not met.			
6.02.00	<b>Torque Requirements</b>			
6.02.01	Accelerating torque at any speed with the lowest permissible starting voltage shall be at least 10% motor full load torque.			
6.02.02	Pull out torque at rated voltage shall not be less than 205% of full load torque. It shall be 275% for crane duty motors.			
6.03.00	<b>Starting voltage requirement</b> (a) Up to 85% of rated voltage for ratings below 110 KW			
7.00.00	<b>DESIGN AND CONSTRUCTIONAL FEATURES</b>			
7.01.00	Suitable single phase space heaters shall be provided on motors rated 30KW and above to maintain windings in dry condition when motor is standstill. Separate terminal box for space heaters & RTDs shall be provided. However for flame proof motors, space heater terminals inside the main terminal box may be acceptable.			
7.02.00	All motors shall be either Totally enclosed fan cooled (TEFC) or totally enclosed tube ventilated (TETV) or Closed air circuit air cooled (CACA) type.			
KAHALGAON SUPER THERMAL POWER STATION STAGE-I (4x210 MW)	BIDDING DOC. NO.: CS-4210-104A(R&M)-2	TECHNICAL SPECIFICATION FOR RENOVATION & RETROFITTING OF ESP	PART – B SUB-SECTION II- E-02 MOTORS	Page 3 of 9



CLAUSE NO.	TECHNICAL REQUIREMENTS				
7.03.00	<p>Winding and Insulation</p> <p>(a) Type : Non-hygroscopic, oil resistant, flame resistant</p> <p>(b) Starting duty : Two hot starts in succession, with motor initially at normal running temperature.</p> <p>(d) 240VAC, 415V AC : Thermal Class ( B ) or better &amp; 220V DC motors</p>				
7.05.00	Motors with heat exchangers shall have dial type thermometer with adjustable alarm contacts to indicate inlet and outlet primary air temperature.				
7.06.00	Noise level for all the motors shall be limited to 85dB(A) except for BFP motor for which the maximum limit shall be 90dB(A). Vibration shall be limited within the limits prescribed in IS:12075 / IEC 60034-14 . Motors shall withstand vibrations produced by driven equipment.				
7.08.00	Motor body shall have two earthing points on opposite sides.				
7.11.00	The spacing between gland plate & centre of terminal stud shall be as per Table-I.				
KAHALGAON SUPER THERMAL POWER STATION STAGE-I (4x210 MW)	BIDDING DOC. NO.: CS-4210-104A(R&M)-2	TECHNICAL SPECIFICATION FOR RENOVATION & RETROFITTING OF ESP	PART – B SUB-SECTION II- E-02 MOTORS	Page 4 of 9	

CLAUSE NO.	TECHNICAL REQUIREMENTS				
7.12.00	All motors shall be so designed that maximum inrush currents and locked rotor and pullout torque developed by them at extreme voltage and frequency variations do not endanger the motor and driven equipment.				
8.00.00	The ratio of locked rotor KVA at rated voltage to rated KW shall not exceed the following (without any further tolerance)				
	(a) Below 110KW	:	10.0		
KAHALGAON SUPER THERMAL POWER STATION STAGE-I (4x210 MW)	BIDDING DOC. NO.: CS-4210-104A(R&M)-2	TECHNICAL SPECIFICATION FOR RENOVATION & RETROFITTING OF ESP	PART – B SUB-SECTION II- E-02 MOTORS	Page 5 of 9	

CLAUSE NO.	TECHNICAL REQUIREMENTS			
<p>10.02.00</p> <p>10.02.01</p> <p>10.02.02</p>	<div data-bbox="1312 92 1425 149" style="float: right; border: 1px solid black; padding: 2px;"> <b>एनटीपीसी</b>  <b>NTPC</b> </div> <p><b>LT Motors</b></p> <p>LT Motors supplied shall be of type tested design. During detailed engineering, the contractor shall submit for employer's approval the reports of all the type tests as listed in this specification and carried out within last <i>ten</i> years from the date of bid opening. These reports should be for the test conducted on the equipment similar to those proposed to be supplied under this contract and the test(s) should have been either conducted at an independent laboratory or should have been witnessed by a client.</p> <p>However if the contractor is not able to submit report of the type test(s) conducted within last ten years from the date of bid opening, or in the case of type test report(s) are not found to be meeting the specification requirements, the contractor shall conduct all such tests under this contract at no additional cost to the employer either at third party lab or in presence of client/ employer's representative and submit the reports for approval.</p>			
<p>KAHALGAON SUPER THERMAL POWER STATION STAGE-I (4x210 MW)</p>	<p>BIDDING DOC. NO.: CS-4210-104A(R&amp;M)-2</p>	<p>TECHNICAL SPECIFICATION FOR RENOVATION &amp; RETROFITTING OF ESP</p>	<p>PART – B SUB-SECTION II- E-02 MOTORS</p>	<p>Page 7 of 9</p>

CLAUSE NO.	TECHNICAL REQUIREMENTS				
10.03.00	<p>All acceptance and routine tests as per the specification and relevant standards shall be carried out. Charges for these shall be deemed to be included in the equipment price.</p>				
<b>KAHALGAON SUPER THERMAL POWER STATION STAGE-I (4x210 MW)</b>	<b>BIDDING DOC. NO.:</b> CS-4210-104A(R&M)-2	<b>TECHNICAL SPECIFICATION FOR RENOVATION &amp; RETROFITTING OF ESP</b>	<b>PART – B SUB-SECTION II- E-02 MOTORS</b>	<b>Page 8 of 9</b>	



**TABLE - I**

**DIMENSIONS OF TERMINAL BOXES FOR LV MOTORS**

<b>Motor MCR in KW of UP to 3 KW</b>	<b>Minimum distance between centre of stud and gland plate in mm As per manufacturer's practice.</b>
--	--

Above 3 KW - upto 7 KW	85
Above 7 KW - upto 13 KW	115
Above 13 KW - upto 24 KW	167
Above 24 KW - upto 37 KW	196
Above 37 KW - upto 55 KW	249
Above 55 KW - upto 90 KW	277
Above 90 KW - upto 125 KW	331
Above 125 KW-upto 200 KW	203

**PHASE TO PHASE/ PHASE TO EARTH AIR CLEARANCE:**

NOTE: Minimum inter-phase and phase-earth air clearances for LT motors with lugs installed shall be as follows:

<b>Motor MCR in KW</b>	<b>Clearance</b>
UP to 110 KW	10mm
Above 110 KW and upto 150 KW	12.5mm
Above 150 KW	19mm

## TECHNICAL SPECIFICATION OF AC FUSE DB

AC fuse boards shall be supplied including the cable glands and lugs for termination of incoming and outgoing cables. Incoming power cable size shall be 3.5C x 50 sq. mm AL conductor and outgoing cable sizes shall be finalized during detailed engineering.

- 1) All fuse boards shall be metal enclosed, fixed type, non-compartmentalized construction, suitable for indoor/ outdoor mounting on wall or steel structure.
- 2) The fuse board frame shall be fabricated using suitable mild steel structures or pressed and shaped cold rolled sheet steel of thickness not less than 2.0 mm. The frames shall be enclosed by cold rolled sheet steel of thickness not less than 1.6 mm.
- 3) The fuse boards shall be provided with doors on the front. The doors shall preferably be in two halves with hinges at the extreme ends and locking facility at the centre.
- 4) Suitable EPDM/Neoprene gaskets shall be provided to make fuse boards completely dust and vermin-proof with a degree of protection of IP-52 for indoor and IP-54 for outdoor application, as per IS: 13947.
- 5) Each AC fuse board shall comprise of the following:
  - (a.) 1 no. 63A TPN switch as incomer.
  - (b.) 100 A, 3-phase, 4-wire, fully insulated (PVC sleeved or epoxy coated) busbars.
  - (c.) 2 nos. 16 A single phase switch fuse units, 2 nos. 32 A TPN switch fuse Units, 4 nos. 16 A TPN switch fuse units as outgoing feeders or alternatively 32/16 amps MCCB can be provided.
  - (d.) 3 nos. indicating lamps with resistors and coloured lenses (R, Y, B) for incoming supply monitoring.(Minimum 8 nos. AC fuse board shall be provided in total)
- 7) The fuses shall be mounted in an insulating fuse carrier and it shall be possible to replace the outgoing feeder fuses without disturbing the other feeders. The handle of incoming switch shall be mounted on the door of the fuse board, with padlocking facility in both 'ON' and 'OFF' positions. The outgoing feeder switches shall preferably be of rotary type.
- 8) Cable entry facilities shall be provided at top / bottom with removable gland plates of suitable thickness. All incoming and outgoing cables shall be terminated on suitable terminal blocks.

Specification for other electrical items is included separately in the technical specification.

## **SUB-SECTION-II-E-06**

### **LT POWER CABLE**

CLAUSE NO.	TECHNICAL REQUIREMENTS			
1.00.00	<b>CODES &amp; STANDARDS</b>			
1.01.00	<p>All standards, specifications and codes of practice referred to herein shall be the latest editions including all applicable official amendments and revisions as on date of opening of bid. In case of conflict between this specification and those (IS : codes, standards, etc.) referred to herein, the former shall prevail. All the cables shall conform to the requirements of the following standards and codes:</p> <p>IS :1554 - I      PVC insulated (heavy duty) electric cables for working voltages upto and including 1100V.</p> <p>IS : 3961          Recommended current ratings for cables</p> <p>IS : 3975          Low carbon galvanised steel wires, formed wires and tapes for armouring of cables.</p> <p>IS : 5831          PVC insulation and sheath of electrical cables.</p> <p>IS : 8130          Conductors for insulated electrical cables and flexible cords.</p> <p>IS : 10418        Specification for drums for electric cables.</p> <p>IS : 10810        Methods of tests for cables.</p> <p>ASTM-D –2843    Standard test method for density of smoke from the burning or decomposition of plastics.</p> <p>IEC-754 (Part-I)    Tests on gases evolved during combustion of electric cables.</p> <p>IEC-332            Tests on electric cables under fire conditions. Part-3: Tests on bunched wires or cables (Category-B).</p>			
2.00.00	<b>TECHNICAL REQUIREMENTS</b>			
2.01.00	The cables shall be suitable for laying on racks, in ducts, trenches, conduits and under ground buried installation with chances of flooding by water.			
2.02.00	All cables including EPR cables shall be flame retardant, low smoke (FRLS) type designed to withstand all mechanical, electrical and thermal stresses develop under steady state and transient operating conditions as specified elsewhere in this specification.			
2.03.00	Conductor of control cables shall be made of stranded, plain annealed copper.			
2.04.00	PVC insulation shall be suitable for continuous conductor temperature of 70 deg C and short circuit conductor temperature of 160 deg. C.			
2.05.00	The cable cores shall be laid up with fillers between the cores wherever necessary. It shall not stick to insulation and inner sheath. All the cables, other			
KAHALGAON SUPER THERMAL POWER STATION STAGE-I (4x210 MW)	BIDDING DOC. NO.: CS-4210-104A(R&M)--2	TECHNICAL SPECIFICATION FOR RENOVATION & RETROFITTING OF ESP	PART – B SUB-SECTION II- E-07 LT CONTROL CABLES	Page 1 of 6

CLAUSE NO.	TECHNICAL REQUIREMENTS																	
2.06.00	<div style="text-align: right; border: 1px solid black; padding: 2px; width: fit-content; margin: 0 auto;"><b>एनटीपीसी NTPC</b></div> <p>than single core unarmoured cables, shall have distinct extruded PVC inner sheath of black colour as per IS: 5831.</p> <p>For multicore armoured cables, the armouring shall be of galvanised steel as follows:</p> <table border="0" style="width: 100%;"> <tr> <td style="width: 30%;">Calculated nominal dia of cable under armour</td> <td>Size and Type of armour</td> </tr> <tr> <td>Upto 13 mm</td> <td>1.4mm dia GS wire</td> </tr> <tr> <td>Above 13 upto 25 mm</td> <td>0.8 mm thick GS formed wire / 1.6 mm dia GS wire</td> </tr> <tr> <td>Above 25 upto 40 mm</td> <td>0.8mm thick GS formed wire / 2.0mm dia GS wire</td> </tr> <tr> <td>Above 40 upto 55mm</td> <td>1.4 mm thick GS formed wire/2.5mm dia GS wire</td> </tr> <tr> <td>Above 55 upto 70 mm</td> <td>1.4mm thick GS formed wire / 3.15mm dia GS wire</td> </tr> <tr> <td>Above 70mm</td> <td>1.4 mm thick GS formed wire / 4.0 mm dia GS wire</td> </tr> </table> <p>The gap between armour wires / formed wires shall not exceed one armour wire / formed wire space and there shall be no cross over / over-riding of armour wire / formed wire. The minimum area of coverage of armouring shall be 90%. The breaking load of armour joint shall not be less than 95% of that of armour wire / formed wire. Zinc rich paint shall be applied on armour joint surface.</p>				Calculated nominal dia of cable under armour	Size and Type of armour	Upto 13 mm	1.4mm dia GS wire	Above 13 upto 25 mm	0.8 mm thick GS formed wire / 1.6 mm dia GS wire	Above 25 upto 40 mm	0.8mm thick GS formed wire / 2.0mm dia GS wire	Above 40 upto 55mm	1.4 mm thick GS formed wire/2.5mm dia GS wire	Above 55 upto 70 mm	1.4mm thick GS formed wire / 3.15mm dia GS wire	Above 70mm	1.4 mm thick GS formed wire / 4.0 mm dia GS wire
Calculated nominal dia of cable under armour	Size and Type of armour																	
Upto 13 mm	1.4mm dia GS wire																	
Above 13 upto 25 mm	0.8 mm thick GS formed wire / 1.6 mm dia GS wire																	
Above 25 upto 40 mm	0.8mm thick GS formed wire / 2.0mm dia GS wire																	
Above 40 upto 55mm	1.4 mm thick GS formed wire/2.5mm dia GS wire																	
Above 55 upto 70 mm	1.4mm thick GS formed wire / 3.15mm dia GS wire																	
Above 70mm	1.4 mm thick GS formed wire / 4.0 mm dia GS wire																	
2.07.00	<p>Outer sheath shall be of PVC as per IS: 5831 and grey in colour. In addition to meeting all the requirements of Indian Standards referred to, outer sheath of all the cables shall have the following FRLS properties.</p> <p>(a.) Oxygen index of min. 29. (As per IS 10810 Part-58)</p> <p>(b.) Acid gas emission of max. 20% (As per IEC-754-I)</p> <p>(c.) Smoke density rating shall not be more than 60% during Smoke Density Test as per ASTM-D-2843.</p>																	
2.08.00	<p>Cores of the cables of upto 5 cores shall be identified by colouring of insulation. Following colour scheme shall be adopted.</p> <table border="0" style="width: 100%;"> <tr> <td style="width: 15%;">1 core -</td> <td>Red, Black, Yellow or Blue</td> </tr> <tr> <td>2 core -</td> <td>Red &amp; Black</td> </tr> <tr> <td>3 core -</td> <td>Red, Yellow &amp; Blue</td> </tr> <tr> <td>4 core -</td> <td>Red, Yellow, Blue and Black</td> </tr> <tr> <td>5 core -</td> <td>Red, Yellow, Blue, Black and Grey</td> </tr> </table>				1 core -	Red, Black, Yellow or Blue	2 core -	Red & Black	3 core -	Red, Yellow & Blue	4 core -	Red, Yellow, Blue and Black	5 core -	Red, Yellow, Blue, Black and Grey				
1 core -	Red, Black, Yellow or Blue																	
2 core -	Red & Black																	
3 core -	Red, Yellow & Blue																	
4 core -	Red, Yellow, Blue and Black																	
5 core -	Red, Yellow, Blue, Black and Grey																	
KAHALGAON SUPER THERMAL POWER STATION STAGE-I (4x210 MW)	BIDDING DOC. NO.: CS-4210-104A(R&M)--2	TECHNICAL SPECIFICATION FOR RENOVATION & RETROFITTING OF ESP	PART – B SUB-SECTION II- E-07 LT CONTROL CABLES	Page 2 of 6														

CLAUSE NO.	TECHNICAL REQUIREMENTS													
2.09.00	<p>For cables having more than 5 cores, core identification shall be done by numbering the insulation of cores sequentially, starting by number 1 in the inner layer (e.g. say for 10 core cable, core numbering shall be from 1 to 10). The number shall be printed in Hindu-Arabic numerals on the outer surfaces of the cores. All the numbers shall be of the same colour, which shall contrast with the colour of insulation. The colour of insulation for all the cores shall be grey only. The numerals shall be legible and indelible. The numbers shall be repeated at regular intervals along the core, consecutive numbers being inverted in relation to each other. When the number is a single numeral, a dash shall be placed underneath it. If the number consists of two numerals, these shall be disposed one below the other and a dash placed below the lower numeral. The spacing between consecutive numbers shall not exceed 50 mm.</p>													
2.10.00	<p>In addition to manufacturer's identification on cables as per IS, following marking shall also be provided over outer sheath:</p> <p>(a.) Cable size and voltage grade - To be embossed</p> <p>(b.) Word 'FRLS' at every 5 metre - To be embossed</p> <p>(c.) Sequential marking of length of the cable in metres at every one metre - To be embossed / printed.</p> <p>The embossing / printing shall be progressive, automatic, in line and marking shall be legible and indelible. For EPR cables identification shall be printed on outer sheath.</p>													
2.11.00	<p>All cables shall meet the fire resistance requirement as per Category-B of IEC-332 Part-3.</p>													
2.12.00	<p>Allowable tolerances on the overall diameter of the cables shall be <math>\pm 2</math> mm maximum over the declared value in the technical data sheets.</p>													
2.13.00	<p>In plant repairs to the cables shall not be accepted. Pimples, fish eye, blow holes etc. are not acceptable.</p>													
2.14.00	<p>Cable selection &amp; sizing</p> <p>Control cables shall be sized based on the following considerations:</p> <p>(a) The minimum conductor cross-section shall be 1.5 sq.mm.</p> <p>(b) The minimum number of spare cores in control cables shall be as follows:</p> <table border="1" data-bbox="386 1528 1128 1816"> <thead> <tr> <th>No. of cores in cable</th> <th>Min. No. of spare cores</th> </tr> </thead> <tbody> <tr> <td>2C, 3C</td> <td>NIL</td> </tr> <tr> <td>5C</td> <td>1</td> </tr> <tr> <td>7C-12C</td> <td>2</td> </tr> <tr> <td>14C &amp; above</td> <td>3</td> </tr> </tbody> </table>				No. of cores in cable	Min. No. of spare cores	2C, 3C	NIL	5C	1	7C-12C	2	14C & above	3
No. of cores in cable	Min. No. of spare cores													
2C, 3C	NIL													
5C	1													
7C-12C	2													
14C & above	3													
KAHALGAON SUPER THERMAL POWER STATION STAGE-I (4x210 MW)	BIDDING DOC. NO.: CS-4210-104A(R&M)--2	TECHNICAL SPECIFICATION FOR RENOVATION & RETROFITTING OF ESP	PART – B SUB-SECTION II- E-07 LT CONTROL CABLES	Page 3 of 6										

CLAUSE NO.	TECHNICAL REQUIREMENTS			
2.14.01	Cable lengths shall be considered in such a way that straight through cable joints are avoided.			
2.14.02	Cables shall be armoured type if laid directly buried.			
3.00.00	<b>CONSTRUCTIONAL FEATURES</b>			
3.01.00	1.1 KV Grade Control Cables shall have stranded copper conductor and shall be multicore PVC insulated, PVC inner sheathed, armoured / unarmoured, FRLS PVC outer sheathed conforming to IS: 1554. (Part-I).			
4.00.00	<p><b>CABLE DRUMS</b></p> <p>(a.) Cables shall be supplied in non returnable wooden or steel drums of heavy construction. The surface of the drum and the outer most cable layer shall be covered with water proof cover. Both the ends of the cables shall be properly sealed with heat shrinkable PVC/ rubber caps secured by 'U' nails so as to eliminate ingress of water during transportation, storage and erection. Wood preservative anti-termite treatment shall be applied to the entire drum. Wooden drums shall comply with IS: 10418.</p> <p>(b.) Each drum shall carry manufacturer's name, purchaser's name, address and contract number, item number and type, size and length of cable and net gross weight stenciled on both the sides of the drum. A tag containing same information shall be attached to the leading end of the cable. An arrow and suitable accompanying wording shall be marked on one end of the reel indicating the direction in which it should be rolled.</p> <p>(c.) The standard drum length for control cables shall not be less than 1000 metres. The length per drum shall be subjected to a maximum tolerance of +/- 5% of the standard drum length. The Employer shall have the option of rejecting cable drums with shorter lengths.</p>			
5.00.00	<p><b>TESTS</b></p> <p>All equipments to be supplied shall be of type tested design. During detailed engineering, the contractor shall submit for Employer's approval the reports of all the type tests as listed in this specification and carried out within last ten years from the date of bid opening. These reports should be for the test conducted on the equipment similar to those proposed to be supplied under this contract and the test(s) should have been either conducted at an independent laboratory or should have been witnessed by a client.</p>			
KAHALGAON SUPER THERMAL POWER STATION STAGE-I (4x210 MW)	BIDDING DOC. NO.: CS-4210-104A(R&M)--2	TECHNICAL SPECIFICATION FOR RENOVATION & RETROFITTING OF ESP	PART – B SUB-SECTION II- E-07 LT CONTROL CABLES	Page 4 of 6

CLAUSE NO.	TECHNICAL REQUIREMENTS																																									
5.01.00  5.01.01	<p>However if the contractor is not able to submit report of the type test(s) conducted within last ten years from the date of bid opening, or in the case of type test report(s) are not found to be meeting the specification requirements, the contractor shall conduct all such tests under this contract at no additional cost to the Employer either at third party lab or in presence of client /Employers representative and submit the reports for approval.</p> <p>All acceptance and routine tests as per the specification and relevant standards shall be carried out. Charges for these shall be deemed to be included in the equipment price</p> <p>The type test reports once approved for any projects shall be treated as reference. For subsequent projects of NTPC, an endorsement sheet will be furnished by the manufacturer confirming similarity and "No design Change". Minor changes if any shall be highlighted on the endorsement sheet.</p> <p><b>TYPE TESTS</b></p> <p>The reports for the following type tests shall be submitted for one size of control cables. Size shall be decided by the employer during detailed engineering</p> <table border="1" data-bbox="375 919 1300 1839"> <thead> <tr> <th data-bbox="375 919 516 951">S. No.</th> <th data-bbox="516 919 971 951">Type Test</th> <th data-bbox="971 919 1300 951">Remarks</th> </tr> </thead> <tbody> <tr> <td colspan="3" data-bbox="375 982 1300 1014" style="text-align: center;"><b>For Conductor</b></td> </tr> <tr> <td data-bbox="375 1045 516 1077">1.</td> <td data-bbox="516 1045 971 1077">Resistance test</td> <td data-bbox="971 1045 1300 1077"></td> </tr> <tr> <td colspan="3" data-bbox="375 1108 1300 1140" style="text-align: center;"><b>For Armour Wires / Formed Wires (If applicable)</b></td> </tr> <tr> <td data-bbox="375 1171 516 1203">2.</td> <td data-bbox="516 1171 971 1203">Measurement of Dimensions</td> <td data-bbox="971 1171 1300 1203"></td> </tr> <tr> <td data-bbox="375 1234 516 1266">3.</td> <td data-bbox="516 1234 971 1266">Tensile Test</td> <td data-bbox="971 1234 1300 1266"></td> </tr> <tr> <td data-bbox="375 1297 516 1329">4.</td> <td data-bbox="516 1297 971 1329">Elongation test</td> <td data-bbox="971 1297 1300 1329"></td> </tr> <tr> <td data-bbox="375 1360 516 1392">5.</td> <td data-bbox="516 1360 971 1392">Torsion test</td> <td data-bbox="971 1360 1300 1392">For round wire only</td> </tr> <tr> <td data-bbox="375 1423 516 1455">6.</td> <td data-bbox="516 1423 971 1455">Wrapping test</td> <td data-bbox="971 1423 1300 1455">For aluminium wires / formed wires only.</td> </tr> <tr> <td data-bbox="375 1507 516 1539">7.</td> <td data-bbox="516 1507 971 1539">Resistance test</td> <td data-bbox="971 1507 1300 1539"></td> </tr> <tr> <td data-bbox="375 1570 516 1602">8(a).</td> <td data-bbox="516 1570 971 1602">Mass of zinc Coating test</td> <td data-bbox="971 1570 1300 1602">For GS wires/formed wires only</td> </tr> <tr> <td data-bbox="375 1633 516 1665">8(b).</td> <td data-bbox="516 1633 971 1665">Uniformity of zinc coating</td> <td data-bbox="971 1633 1300 1665">For GS wires/formed wires only</td> </tr> <tr> <td data-bbox="375 1696 516 1728">9.</td> <td data-bbox="516 1696 971 1728">Adhesion test</td> <td data-bbox="971 1696 1300 1728">For GS wires/formed wires only</td> </tr> </tbody> </table>			S. No.	Type Test	Remarks	<b>For Conductor</b>			1.	Resistance test		<b>For Armour Wires / Formed Wires (If applicable)</b>			2.	Measurement of Dimensions		3.	Tensile Test		4.	Elongation test		5.	Torsion test	For round wire only	6.	Wrapping test	For aluminium wires / formed wires only.	7.	Resistance test		8(a).	Mass of zinc Coating test	For GS wires/formed wires only	8(b).	Uniformity of zinc coating	For GS wires/formed wires only	9.	Adhesion test	For GS wires/formed wires only
S. No.	Type Test	Remarks																																								
<b>For Conductor</b>																																										
1.	Resistance test																																									
<b>For Armour Wires / Formed Wires (If applicable)</b>																																										
2.	Measurement of Dimensions																																									
3.	Tensile Test																																									
4.	Elongation test																																									
5.	Torsion test	For round wire only																																								
6.	Wrapping test	For aluminium wires / formed wires only.																																								
7.	Resistance test																																									
8(a).	Mass of zinc Coating test	For GS wires/formed wires only																																								
8(b).	Uniformity of zinc coating	For GS wires/formed wires only																																								
9.	Adhesion test	For GS wires/formed wires only																																								
KAHALGAON SUPER THERMAL POWER STATION STAGE-I (4x210 MW)	BIDDING DOC. NO.: CS-4210-104A(R&M)--2	TECHNICAL SPECIFICATION FOR RENOVATION & RETROFITTING OF ESP	PART – B SUB-SECTION II- E-07 LT CONTROL CABLES	Page 5 of 6																																						

CLAUSE NO.	TECHNICAL REQUIREMENTS								
5.02.00	S. No.	Type Test	Remarks						
				<b>For PVC insulation &amp; PVC Sheath</b>					
					10.	Test for thickness			
					11.	Tensile strength and elongation test	before ageing and after ageing		
					12.	Ageing in air oven			
					13.	Loss of mass test	For PVC insulation and sheath only		
					14.	Hot deformation test	For PVC insulation and sheath only		
					15.	Heat shock test	For PVC insulation and sheath only		
					16.	Shrinkage test			
					17.	Thermal stability test	For PVC insulation and sheath only		
					18.	Oxygen index test	For outer sheath only		
					19.	Smoke density test	For outer sheath only		
					20.	Acid gas generation test	For outer sheath only		
					<b>For completed cables</b>				
					21.	Insulation resistance test(Volume resistivity method)			
					22.	High voltage test			
					23.	Flammability test as per IEC-332 Part-3 (Category-B)			
					5.02.00	Indicative list of tests/checks, Routine and Acceptance tests shall be as per Quality Assurance & Inspection table of Control Cables enclosed.			
					KAHALGAON SUPER THERMAL POWER STATION STAGE-I (4x210 MW)	BIDDING DOC. NO.: CS-4210-104A(R&M)--2	TECHNICAL SPECIFICATION FOR RENOVATION & RETROFITTING OF ESP	PART – B SUB-SECTION II- E-07 LT CONTROL CABLES	Page 6 of 6

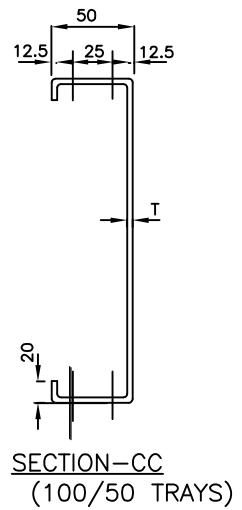
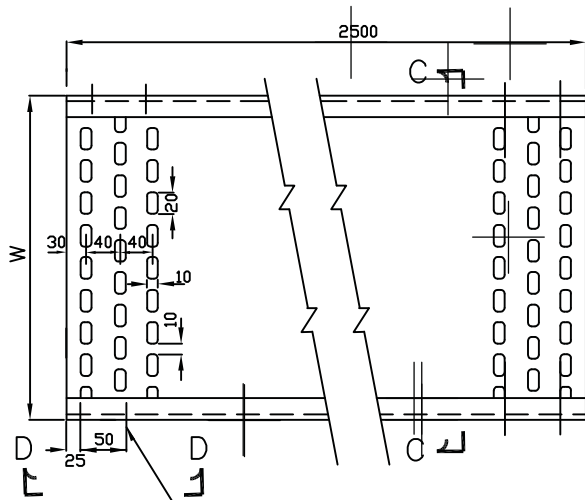

4 HOLES 10mm DIA.

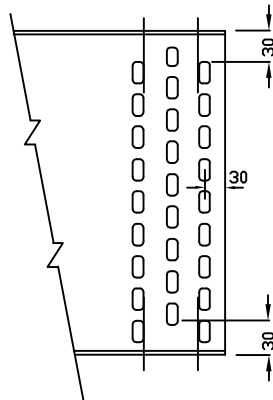

ARRANGEMENT OF PERFORATIONS

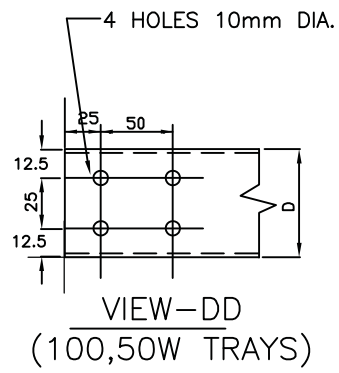

TRAY WIDTH W (mm)	100	50
TRAY DEPTH D (mm)	50	50
T (mm)	2	2

PERFORATED TYPE TRAY



TYPICAL DETAILS OF CABLE TRAYS AND ACCESSORIES

DWG. NO.

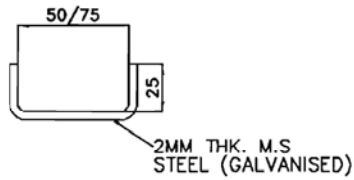
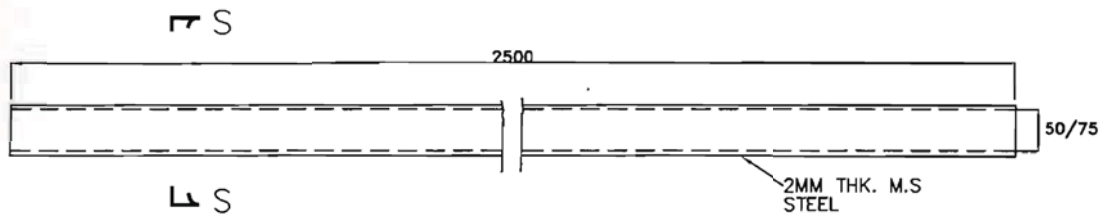

SECTION S-S

CABLE TROUGHS

~~SEE GENERAL NOTES IN SHEET 11.~~



TYPICAL DETAILS OF  
CABLE TRAY AND ACCESSORIES

BHEL DRAWING NO.

~~PE-DG-427-507-E005~~

~~SH-10 OF 11~~

REV 00

	<b>STANDARD QUALITY PLAN</b>		<b>SPEC. NO. :</b>	
	<b>CUSTOMER :</b>		<b>QP NO. : PED-506-40-Q-006, REV-02</b>	
	<b>PROJECT :</b>		<b>DATE: 27.02.2020</b>	
	<b>ITEM: AC ELECT. MOTORS UPTO 55KW (LV (415V))</b>		<b>SECTION: II</b>	
<b>MANUFACTURER/ BIDDER/ SUPPLIER NAME &amp; ADDRESS</b>		<b>PO NO.:</b>		<b>SHEET 1 OF 2</b>
<b>SYSTEM:</b>				

Sl No.	Component & Operations	Class	Type of Check	Quantum Of check	Reference Document	Acceptance NORMS	FORMAT OF RECORD				AGENCY	
							M	C/N	D	M		C
1	ASSEMBLY	MA	VISUAL	100%	MFG. SPEC.	MFG. SPEC.	9					
1.0	1.WORKMANSHIP 2.DIMENSIONS 3.CORRECTNESS COMPLETENESS TERMINATIONS/ MARKING/COLOUR CODE	MA	-DO-	-DO-	MFG. DRG/ MFG. SPEC.	MFG. DRG/ MFG. SPEC.	-DO-	P	P	P	P	
2.0	1.SHADE	MA	VISUAL	SAMPLE	MFG. SPEC/ APPROVED DATASHEET	SAME AS COL.7	LOG BOOK	P	P	P	P	
3.0	1.ROUTINE TEST INCLUDING SPECIAL TEST 2.OVERALL DIMENSIONS & ORIENTATION	MA	-DO-	100%	IS-325 / IS-12615/ APPROVED DATA SHEET	SAME AS COL.7	TEST/ INSPN. REPORT	P	P	P	P	NOTE-1 & NOTE-2
	MEASUREMENT & VISUAL	MA	100%	100%	APPROVED DRG/DATA SHEET	APPROVED DRG/DATA SHEET	TEST/ INSPN. REPORT	P	P	P	P	NOTE-1 & NOTE-2

<b>BHEL</b>			
<b>ENGINEERING</b>		<b>QUALITY</b>	
Sign & Date	Name	Sign & Date	Name
<i>[Signature]</i>	Meera K.	<i>[Signature]</i>	KUNAL
Prepared by:		Checked by:	
Reviewed by:	P. Dutta	Reviewed by:	

<b>BIDDER/ SUPPLIER</b>	
Sign & Date	
Seal	

<b>FOR CUSTOMER REVIEW &amp; APPROVAL</b>			
Doc No:	Sign & Date	Name	Seal
Reviewed by:			
Approved by:			

	<b>STANDARD QUALITY PLAN</b>			SPEC. NO.:	
	CUSTOMER:			QP NO.: PED-506-00-Q-006, REV.02	
	PROJECT:			DATE: 27.02.2020	
	ITEM: AC ELECT. MOTORS UPTO 55KW (LV (415V))			PO NO.:	
MANUFACTURER/BIDDER/ SUPPLIER NAME & ADDRESS			SYSTEM: II		SECTION: II
SHEET 2 OF 2					

SI No.	Component & Operations	Characteristics	Class	Type of Check	Quantum Of check		Reference Document	Acceptance NORMS	FORMAT OF RECORD			AGENCY	(#) APPLICABLE FOR EXPORT JOBS
					M	C/N							
1	2	3.NAMEPLATE DETAILS	4	5	100%	6	7	8	9				
			MA	VISUAL	100%		IS-325 / IS-12615 / APPROVED DATA SHEET	SAME AS COL7	TEST/INSPN. REPORT	D	M	C	N
4.0	PACKING	SURFACE FINISH & COMPLETENESS	MA	VISUAL	100%		AS PER MFG. STANDARD / APPROVED PACKING DRAWING. (#)	AS PER MFG. STANDARD / APPROVED PACKING DRAWING. (#)	INSPC. REPORT	P	P	W	W

**NOTES:**

- 1 ROUTINE TESTS ON 100% MOTORS SHALL BE DONE BY THE VENDOR. HOWEVER, BHEL/CUSTOMER SHALL WITNESS ROUTINE TESTS ON RANDOM SAMPLES. THE SAMPLING PLAN SHALL BE MUTUALLY AGREED UPON
- 2 FOR EXHAUST/VENTILATION FAN MOTORS OF RATING UPTO 1.5KW, ONLY ROUTINE TEST CERTIFICATES SHALL BE FURNISHED FOR SCRUTINY.
- 3 IN CASE TEST CERTIFICATES FOR THESE TESTS ON SIMILAR TYPE, SIZE AND DESIGN OF MOTOR FROM INDEPENDENT LABORATORY ARE AVAILABLE, THESE TEST MAY NOT BE REPEATED.
- 4 BHEL RESERVES THE RIGHT TO PERFORM REPEAT TEST, IF REQUIRED.
- 5 AFTER PACKING AND PRIOR TO ISSUE MDCC, PHOTOGRAPHS OF ITEMS TO BE DESPATCHED SHALL BE SENT TO BHEL FOR REVIEW.
- 6 IN CASE, ANY CHANGES IN QP COMMENTED BY CUSTOMER AT CONTRACT STAGE SHALL BE CARRIED OUT BY BIDDER WITHOUT ANY IMPLICATION TO BHEL/CUSTOMER.

**LEGENDS:**

- \*RECORDS, IDENTIFIED WITH "TICK" (✓) SHALL BE ESSENTIALLY INCLUDED BY SUPPLIER IN QA DOCUMENTATION.
- \*\* M: SUPPLIER/ MANUFACTURER/ SUB-SUPPLIER, B: MAIN SUPPLIER/ BHEL/ THIRD PARTY INSPECTION AGENCY, C: CUSTOMER,
- P: PERFORM, W: WITNESS, V: VERIFICATION, AS APPROPRIATE
- MA: MAJOR, MI: MINOR, CR: CRITICAL
- D: DOCUMENT

BHEL			
ENGINEERING		QUALITY	
Prepared by:	Sign & Date	Name	Sign & Date
	<i>[Signature]</i>	Hema K.	<i>[Signature]</i>
Reviewed by:	Checked by:	Reviewed by:	
	<i>[Signature]</i>	<i>[Signature]</i>	
	02/15/2020		

BIDDER/ SUPPLIER	
Sign & Date	
Seal	

FOR CUSTOMER REVIEW & APPROVAL			
Doc No:	Sign & Date	Name	Seal
Reviewed by:			
Approved by:			

Sl. No	Component & Operations	Characteristics	Class	Type of check	Quantum of check		Reference Document	Acceptance Norms	Record Format	Agency			Remarks
					M	C/N				D	M	C	
1	2	3	4	5	6	7	8	9	10	11			
<b>Item: 1.1 KV Power (XLPE &amp; PVC) Insulated FRLS cables</b> <b>STANDARD QUALITY PLAN (CONFORMING TO CODE: IS 1554 PART 1, IS 7098 Part-1 AND NTPC TECHNICAL SPECIFICATION)</b> <b>Q.P. NO. 0000-999- QOE-S-041</b> <b>REV-01 DATE: 29/11/2018</b> <b>Page 1 of 9</b>													
<b>INSTRUCTIONS:</b> 1) Cable manufacturer to maintain records to show co-relation of raw materials to finished cables i.e raw material batch/lot no. should be traceable to the cable drum. 2) Cable manufacturer to maintain all quality control records identified as per all QP stages enumerated below whether it is identified for NTPC verification or witness or not.													
<b>A. Raw material/ Brought out Items</b>													
1.01	Aluminum	1. Make	MA	Verify	100%	MANUFACTURER APPROVED SOURCES	MANUFACTURER APPROVED SOURCES	QCR	V	--	--		
		2. Resistivity	MA	Elect	As per Cable Mnftr Std.	IS5082	IS5082	-do-	P	--	--		
1.02	PVC / XLPE/compound for insulation	1. Make	MA	Verify	--do--	MANUFACTURER APPROVED SOURCES	MANUFACTURER APPROVED SOURCES	-do-	V	V	--		
		2. Type/Grade	MA	Verify	100%	NTPC ADS	NTPC ADS	-do-	V	V	V		
		3. All acceptance test as per manufacturer norms including thermal stability test for PVC insulation	MA	Verify	As per manufacturer norms	NTPC ADS	NTPC ADS	-do-	V	V	V	Refer note 1	
1.03	PVC Compound for Inner sheath	1. Make	MA	Verify	--do--	MANUFACTURER APPROVED SOURCES	MANUFACTURER APPROVED SOURCES	-do-	V	V	V		
		2. Type/Grade	MA	Verify	--do--	NTPC ADS	NTPC ADS	-do-	V	V	V		
1.04	Steel wire / Formed Wire ( As applicable )	1. Make	MA	Verify	--do--	MANUFACTURER APPROVED SOURCES	MANUFACTURER APPROVED SOURCES	-do-	V	V	V		
		2. Dimension	MA	Meas	1 sample from each size / lot	NTPC APPROVED DATA SHEET & IS 3975	NTPC APPROVED DATA SHEET & IS 3975	-do-	P	--	--		
		3. All acceptance tests as per IS 3975	MA	Verify	As per IS 3975	IS 3975	IS 3975	Supplier TC	V	V	--		
1.05	PVC compound for Sheath	1. Make	MA	Verify	As per manufacturer norms	MANUFACTURER APPROVED SOURCES	MANUFACTURER APPROVED SOURCES	QCR	V	V	--		
		2. Type / Grade	MA	Verify	100%	NTPC ADS	NTPC ADS	QCR	V	V	V		

Page 1 of 9

LEGEND:- \*RECORDS, IDENTIFIED WITH "TICK" UNDER COLUMN "D" SHALL BE ESSENTIALLY INCLUDED BY SUPPLIER IN QA DOCUMENTATION.  
 -M:MANUFACTURER/SUPPLIER, C:MAIN SUPPLIER, N:NTPC, P:PERFORM W:WITNESS,V:VERIFICATION AS APPROPRIATE, CHP: NTPC SHALL IDENTIFY IN COLUMN "N" AS "W"  
 FORMAT NO:QS-01-QAI-P-10/F3-RI



Item: 1.1 KV Power (XLPE & PVC) Insulated FRILS cables

STANDARD QUALITY PLAN (CONFORMING TO CODE: IS 1554 PART 1, IS 7098 Part-1 AND NTPC TECHNICAL SPECIFICATION)

QP. NO. 0000-999- QOE- S-041  
REV-01 DATE:  
Page 2 of 9

REVIEWED BY  
AMAN PANDEY  
RAJESH SHARMA  
S K LAL  
DINESH KUMAR

APPROVED BY  
K.K. OJHA

Sl. No	Component & Operations	Characteristics	Class	Type of check	Quantum of check		Reference Document	Acceptance Norms	Record Format	Agency			Remarks
					M	C/N				D*	M	C	
1	2	3. All acceptance test as per manufacturer norms 4. Thermal Stability 5. Oxygen Index 6. Acid Gas Emission	4 MA MA MA MA	5 Verify Chem Chem Chem	6 As per manufacturer norms One sample / Batch --do-- One sample / Batch	C/N As per manufacturer norms -- --	7 NTPC ADS NTPC ADS NTPC ADS/ IS 10810 Part 58 NTPC ADS / IEC60754	8 NTPC ADS NTPC ADS NTPC ADS/ IS 10810 Part 58 NTPC ADS / IEC60754	9 QCR QCR --do-- QCR	10 V V P P P	10 V V P P P	11 Refer note 1 -- -- -- --	
1.06	Wooden Drum	1. Dimension	MI	Meas	One sample / Batch	--	IS 10418	IS10418	--do--	P	--	--	
1.07	Steel Drum	2. Anti termite treatment	MI	Chem	Cable manuf. std	--	CABLE MANUF. STD.	CABLE MANUF. STD.	COC	V	V	V	COC from drum manuf.
		1. Dimension	MI	Meas	--do--	--	--do--	--do--	QCR	P	--	--	
		2. Surface finish	MI	Meas	--do--	--	--do--	--do--	--do--	P	--	--	
B	Process & Stage Inspection												
2.01	Wire Drawing	1. Surface finish	MA	Visual	One sample/Settin g of each size	--	SHOULD BE SMOOTH & FREE FROM SCRATCHES	SHOULD BE SMOOTH & FREE FROM SCRATCHES	QCR	P	--	--	
		2. Wire Diameter	MA	Meas	--do--	--	NTPC ADS	NTPC ADS	--do--	P	--	--	
		3. Tensile test	CR	Mech	--do--	--do--	--do--	--do--	--do--	P	V	V	Refer Sl. No.3.03 (iii)
		4. Wrapping test	CR	Mech	--do--	--do--	--do--	--do--	--do--	P	V	V	
		1. No. of wires	MA	Meas	--do--	--	NTPC ADS	NTPC ADS	--do--	P	--	--	
		2. Dia of wire	MA	Meas	--do--	--	--do--	--do--	--do--	P	--	--	
		3. Dimension of Conductor	MA	Meas	--do--	--	--do--	--do--	--do--	P	--	--	
		4. Direction of lay	MA	Visual	--do--	---	--do--	--do--	--do--	P	--	--	
		5. Records of strand breakage / welding during conductor stranding	MA	Verify	--do--	--	IS 8130	IS8130	--do--	P	--	--	
		6. Surface finish	MA	Visual	--do--	-	--do--	--do--	--do--	P	--	--	
		7. DC Resistance	CR	Meas	--do--	-	IS8130/NTPC ADS	IS8130/NTPC ADS	--do--	P	--	--	
2.03	Insulation extrusion	1. Surface finish	MA	Visual	One sample/Settin g of each size	-	NTPC spec	SHOULD BE SMOOTH, NO POROSITY IS PERMITTED.	QCR	P	--	--	XLPE/ PVC compound shall be preferably loaded in to extruder by suction method.

LEGEND:- \*RECORDS, IDENTIFIED WITH "TICK" UNDER COLUMN "D" SHALL BE ESSENTIALLY INCLUDED BY SUPPLIER IN QA DOCUMENTATION.  
-M:MANUFACTURER/SUPPLIER, C:MAIN SUPPLIER, N:NTPC, P:PERFORM W:WITNESS,V:VERIFICATION AS APPROPRIATE, CHP: NTPC SHALL IDENTIFY IN COLUMN "N" AS "W"  
FORMAT NO:QS-01-QAI-P-10/03-R1

Sl. No	Component & Operations	Characteristics	Class	Type of check	Quantum of check		Reference Document	Acceptance Norms	Record Format	Agency			Remarks
					M	C/N				D*	M	C	
1	2	3	4	5	6	7	8	9	10	11			
		2. Colour of cores	MA	Visual	One sample/Setting of each size	NTPC ADS	NTPC ADS	QCR	P				
		3. Thickness	CR	Meas	--do--	NTPC ADS	NTPC ADS	--do--	P				
		4. Spark Test	CR	Elect	100%	CABLE MANUF. STD.	No FAILURE	--do--	P	V	V	1. Spark test failure record is to be verified. 2. Core repairing not permitted	
		5. Hot Set	CR	Mech	One sample/Setting of each size	IS 7098- Part I	IS 7098- Part I	--do--	P			Sample is to be taken from both top & bottom end	
2.04	Laying up	1. Core sequence	MA	Visual	--do--	IS 1554 (Part I) & IS 7098- Part I	IS 1554 (Part I) & IS 7098- Part I	--do--	P				
		2. Direction of lay	MA	Visual	--do--	--do--	--do--	--do--	P				
		3. Dia over laid up core	MA	Meas	--do--	NTPC ADS	NTPC ADS	--do--	P				
2.05	Inner Sheath	1. Colour	MA	Visual	--do--	--do--	--do--	--do--	P				
		2. Surface Finish	MA	Visual	100%	NTPC SPECIFICATION	FISH EYE, BLOW HOLE NOT PERMITTED	--do--	P				
		3. Thickness	MA	Meas	One sample/Setting of each size	NTPC ADS	NTPC ADS	--do--	P				
		4. Dia over inner sheath	M1	Meas	--do--	--do--	--do--	--do--	P				
2.06	Armouring (As Applicable)	1. Dimension	MA	Meas	--do--	--do--	--do--	--do--	P				
		2. No. of wires / strip	MA	Meas	--do--	--do--	--do--	--do--	P				
		3. Direction of lay	MA	Visual	--do--	IS 1554 (Part I) & IS 7098- Part I	IS 1554 (Part I) & IS 7098- Part I	QCR	P				

APPROVED BY  
K K OJHA

REVIEWED BY  
AMAN PANDEY  
RAJESH SHARMA  
S K LAL  
DINESH KUMAR

QP. NO. 0000-999- QOE- S-041  
REV-01 DATE:  
Page 3 of 9

STANDARD QUALITY PLAN (CONFORMING TO  
CODE: IS 1554 PART I, IS 7098 Part-I AND NTPC  
TECHNICAL SPECIFICATION)

Item: 1.1 KV Power (XLPE  
& PVC) Insulated FRLS  
cables

LEGEND:- \*RECORDS, IDENTIFIED WITH "TICK" UNDER COLUMN "D" SHALL BE ESSENTIALLY INCLUDED BY SUPPLIER IN QA DOCUMENTATION.  
-M:MANUFACTURER/SUPPLIER, C:MAIN SUPPLIER, N:NTPC, P:PERFORM W:WITNESS,V:VERIFICATION AS APPROPRIATE, CHP: NTPC SHALL IDENTIFY IN COLUMN "N" AS "W"

Sl. No	Component & Operations	Characteristics	Class	Type of check	Quantum of check		Reference Document	Acceptance Norms	Record Format	Agency			Remarks
					M	C/N				D*	M	C	
1	2	3	4	5	6	7	8	9	10	11			
		4.Coverage & Quality of armouring	MA	Meas.	100%		Min. area of coverage of armouring shall be 90%. The gap between armour wires / formed wires shall not exceed one armour wire/ formed wire space & there shall be no cross over/ over riding of armour wire / formed wire. Zn rich paint shall be applied on armour joint surface of G.S. Wire. /formed wire. The breaking load of armour wire joint shall not be less than 95% of that of armour wire / formed wire. (As per NTPC specification)	QCR	P	--	--		
		5 Dia over armouring	MA	Meas.	One sample/Setting of each size		NTPC ADS	--do--	P	--	--		
2.07	Outer Sheath	1. Surface finish	MA	Visual	100%		Pimple, Fish Eye, Burnt particles, Blow Hole not permitted. Repairing on outer sheath not permitted. (As per NTPC specification)	--do--	P	--	--	PVC FRLS compound shall be preferably loaded in to extruder by suction method.	
		2.Colour of sheath	MA	Visual	One sample/Setting of each size		NTPC ADS	--do--	P	--	--		
		3. Dia over outer sheath	MA	Meas	--do--		NTPC ADS	--do--	P	--	--		
		4.Thickness of outer sheath	CR	Meas	--do--		--do--	--do--	P	--	--		
		5. Embossing quality	MA	Visual	100%		Drum No., IS1554-1 & IS7098-1, Cable size, Voltage grade & Words "FRLS" at every 5 meter is to be embossed. Embossing shall be automatic, in line & marking shall be legible & indelible. (As per NTPC specification)	--do--	P	--	--	Drum No. on Cable may be embossed/printed	
		6. Sequential marking	MA	Visual	Full length		Sequential marking of length of cable in meter at every one meter is to be embossed / printed. Embossing / printing shall be progressive, automatic, in line & marking shall be legible & indelible. (As per NTPC specification)	--do--	P	--	--		
							In addition, Drum No. is also to be embossed/printed on full cable length	--do--					
C	Finished Cables												
3.01	Type test reports clearance from NTPC	All type tests as per NTPC specification	CR	Doc.	100%	100%	NTPC SPECIFICATION / NTPC ADS / IS 7098-1554 (Part I) & IS 7098-1554 (Part II) & IS	--do--	P	V	V	V	

APPROVED BY  
K K OJHA

REVIEWED BY  
AMAN PANDEY  
RAJESH SHARMA  
S K LAI  
DINESH KUMAR

QP. NO. 0000-999- QOE- S-041  
REV-01 DATE:  
Page 4 of 9

STANDARD QUALITY PLAN (CONFORMING TO  
CODE: IS 1554 PART I, IS 7098 Part-I AND NTPC  
TECHNICAL SPECIFICATION)

Item: 1.1 KV Power (XLPE  
& PVC) Insulated FRLS  
cables

Sl. No	Component & Operations	Characteristics	Class	Type of check		Quantum of check		Reference Document	Acceptance Norms	Record Format	APPROVED BY		
				M	C/N	M	C				N	REVIEWED BY	APPROVED BY
1	2	3	4	5	6	7	8	9	10	11	7098- Part I REVIEWED BY AMAN PANDEY RAJESH SHARMA S K LAL DINESH KUMAR APPROVED BY K KOJHA		
3.02	Routine Tests	1.High Voltage test at room temperature 2.Conductor Resistance	CR	Elect	100%	100%	NTPC ADS / IS 1554 (Part I) & IS 7098- Part I	Test certificate	P	W	V	Refer note 2	
3.03	Acceptance Tests	1. OD of Cable	MA	Meas.	Each type & size of cables as per sampling plan of IS 1554 ( Part I ) & IS 7098- Part I	NTPC ADS	NTPC ADS	--do--	P	W	W		
3.03 (i)	Construction of finished Cable	2. Laying of core 3. Core Identification 4. Colour of outer sheath 5. Inner sheath thickness 6. Inner sheath colour	CR	Visual	--do--	NTPC ADS / IS 1554 (Part I) & IS 7098- Part I	NTPC ADS / IS 1554 (Part I) & IS 7098- Part I	--do--	P	W	W		
3.03 (ii)	Armour wires/ Formed wires ( if applicable)	1. Dimensions 2. No. of wires/ formed wire 3. Tensile test 4. Elongation test 5. Torsion test ( for round wires only) 6. Wrapping test 7. Resistance test	CR	Mech	--do--	NTPC ADS / IS 1554 (Part I) / IS 3975	NTPC ADS / IS 1554 (Part I) / IS 3975	--do--	P	W	W		

Page 5 of 9

LEGEND:- \*RECORDS, IDENTIFIED WITH "TICK" UNDER COLUMN "D" SHALL BE ESSENTIALLY INCLUDED BY SUPPLIER IN QA DOCUMENTATION.  
 -M:MANUFACTURER/SUPPLIER, C:MAIN SUPPLIER, N:NTPC, P:PERFORM W:WITNESS,V:VERIFICATION AS APPROPRIATE, CHP: NTPC SHALL IDENTIFY IN COLUMN "N" AS "V"  
 FORMAT NO:QS-01-QAI-P-10/F3-RI

Sl. No	Component & Operations	Characteristics	Class	Type of check	Quantum of check		Reference Document	Acceptance Norms	Record Format	Agency			Remarks
					M	C/N				D*	M	C	
1	2	3	4	5	6	7	8	9	10	11			
		8. Mass of Zinc coating 9. Uniformity of Zinc Coating	CR	Mech	--do--	--do--	--do--	--do--	✓	P	V	V	
		10. Adhesion test 11. Freedom from defects	CR	Chem.	Each type & size of cables as per sampling plan of IS 1554 (Part I) & IS 7098-Part I	NTPC ADS /IS1554(Part I)/IS3975	NTPC ADS /IS1554(Part I) /IS3975	Test certificate	✓	P	V	V	
			CR	Mech	--do--	--do--	--do--	--do--	✓	P	V	V	
			CR	Visual	--do--	--do--	--do--	--do--	✓	P	V	V	
3.03 (iii)	Conductor	1. Resistance Test	CR	Elect	--do--	--do--	--do--	--do--	✓	P	W	W	
		2. Tensile test ( For aluminum conductor only )	CR	Mech	Each type & size of cables as per sampling plan of IS 1554 (Part I)/7098(Part I)	NTPC ADS/ IS 8130	NTPC ADS/ IS 8130	--do--	✓	P	W	W	
													Test report of manufacturer to be reviewed as per SI. No. 2.01 for Tensile test & wrapping test ( for Aluminum ) in case this test is not applicable for cable under inspection as per IS 8130 cl. 6.2.
		3. Wrapping test (For aluminum conductor only)	CR	Mech	--do--	--do--	--do--	--do--	✓	P	P	W	--do--
3.03 (iv)	PVC / XLPE Insulation & PVC Sheath	1. Thickness of insulation & sheath	CR	Mech	--do--	NTPC ADS/ IS 1554(Part I) & IS 7098-Part I	NTPC ADS/ IS 1554(Part I) & IS 7098-Part I	--do--	✓	P	W	W	

APPROVED BY  
K. K. OJHA

REVIEWED BY  
AMAN PANDEY  
RAJESH SHARMA  
S. K. LAL  
DINESH KUMAR

QP. NO. 0000-999- QOE- S-041  
REV-01 DATE:  
Page 6 of 9

STANDARD QUALITY PLAN (CONFORMING TO  
CODE: IS 1554 PART I, IS 7098 Part-I AND NTPC  
TECHNICAL SPECIFICATION)

Item: 1.1 KV Power (XLPE  
& PVC) Insulated FRLS  
cables



LEGEND:- \*RECORDS, IDENTIFIED WITH "TICK" UNDER COLUMN "D" SHALL BE ESSENTIALLY INCLUDED BY SUPPLIER IN QA DOCUMENTATION.  
-M:MANUFACTURER/SUPPLIER, C:MAIN SUPPLIER, N:NTPC, P:PERFORM W:WITNESS,V:VERIFICATION AS APPROPRIATE, CHF: NTPC SHALL IDENTIFY IN COLUMN "N" AS "Y"  
FORMAT NO:QS-01-QAI-P-10/F3-R1

Sl. No	Component & Operations	Characteristics	Class	Type of check	Quantum of check		Reference Document	Acceptance Norms	Record Format	Agency			Remarks
					M	C/N				D*	M	C	
<b>Item: 1.1 KV Power (XLPE &amp; PVC) Insulated FRLS cables</b> <b>STANDARD QUALITY PLAN (CONFORMING TO CODE: IS 1554 PART 1, IS 7098 Part-I AND NTPC TECHNICAL SPECIFICATION)</b>													
1	2	2. Tensile strength & elongation at break of insulation at break of insulation & outer sheath 3. Tensile strength & elongation of PVC at break of insulation & outer sheath (Ageing Test)	4	5	CR	6	7	8	9	10	11		
		3a. Tensile strength & elongation of XLPE at break of insulation (Ageing Test) 4. Insulation resistance (Volume resistivity method) 5. High voltage test at room temperature 6. Thermal stability on PVC Insulation and outer sheath 7. Hot Set Test (for XLPE Insulation only) 8. Oxygen index Test on outer sheath	CR	Mech	CR	6	NTPC ADS/ IS 1554(Part I) & IS 7098 Part I	NTPC ADS/ IS 1554(Part I) & IS 7098 Part I	Test Certificate	P	W	W	MTR for Ageing Test of the offered lot shall be verified
			CR	Mech	CR	--do--	NTPC ADS/ IS 7098 Part I	NTPC ADS/ IS 7098 Part I	--do--	P	V	V	MTR for Ageing Test of the offered lot shall be verified
			CR	Elect	CR	Each type & size of cables as per sampling plan of IS 1554 ( Part 1 ) & IS 7098- Part I	--do--	NTPC ADS/ IS 1554(Part I) & IS 7098 Part I	--do--	P	W	W	
			CR	Elect	CR	Each type & size of cables as per sampling plan of IS 1554 ( Part 1 ) & IS 7098- Part I	--do--	NTPC ADS/ IS 1554(Part I) & IS 7098 Part I	--do--	P	W	W	
			CR	Chem	CR	One sample of each offered lot of all offered sizes	--do--	NTPC ADS/ IS 1554(Part I) & IS 7098 Part I	--do--	P	W	W	
			CR	Elect	CR	Each type & size of cables as per sampling plan of IS 1554 ( Part 1 ) & IS 7098- Part I	NTPC ADS / IS 1554(Part I) & IS 7098 Part I	NTPC ADS / IS 1554(Part I) & IS 7098 Part I	--do--	P	W	W	
			CR	Chem	CR	One sample of each offered lot of all offered sizes	NTPC ADS / IS 10810 Part 58	NTPC ADS / IS 10810 Part 58	Test certificate	P	W	W	Refer Note 3

APPROVED BY  
  
**K. KOJHA**  
 Director

REVIEWED BY  
 AMAN PANDEY  
 RAJESH SHARMA  
 S. K. LAL  
 DINESH KUMAR

OP. NO. 0000-999- QOE- S-041  
 REV-01 DATE: \_\_\_\_\_  
 Page 7 of 9

of 9  
 "W"  
 P. 10/07.01

LEGEND:- \*RECORDS, IDENTIFIED WITH "TICK" UNDER COLUMN "D" SHALL BE ESSENTIALLY INCLUDED BY SUPPLIER IN QA DOCUMENTATION.  
 -MANUFACTURER/SUPPLIER, C:MAIN SUPPLIER, N:NTPC, P:PERFORM W:WITNESS,V:VERIFICATION AS APPROPRIATE, CHP: NTPC SHALL IDENTIFY

Sl. No	Component & Operations	Characteristics	Class	Type of check	Quantum of check		Reference Document	Acceptance Norms	Record Format	APPROVED BY			Remarks
					M	C/N				D*	M	C	
1	2	3	4	5	6	--do--	7	8	9	10	11		
		9. Smoke density rating test on outer sheath 10. Acid gas generation test on outer sheath 11. Flammability test on completed cable 12. Surface finish & length measurement.	CR	Chem		--do--	NTPC ADS & ASTM D2843	NTPC ADS	--do--	P	W	W	
			CR	Chem		--do--	NTPC ADS & IEC 60754-1	NTPC ADS	Test Certificate	P	W	W	Refer Note 3 Refer Note 3
			CR	Chem	Refer Note 4	Refer Note 4	NTPC ADS & IEC 60332 Part-3 (Category-B)	NTPC ADS	--do--	P	W	W	
			CR	Visual & Meas	100% (COC from Manufacturer to be submitted for surface finish as per specification's requirement)	Refer Note 4	(1) IS1554-1 & IS7098-1, Cable size, Voltage grade & Words "FRLS" at every 5 meter is to be embossed. Embossing shall be automatic, in line & marking shall be legible & indelible. (2) Sequential marking of length of cable in meter at every one meter is to be embossed / printed. Embossing / printing shall be progressive, automatic, in line & marking shall be legible & indelible		--do--	P	W	W	Pimple, Fish Eye, Burnt particles, Blow Hole etc. not permitted. Repairing on outer sheath not permitted.
4	Packing	13. Sequence of cores armour coverage, gap between two consecutive armour/formed wire 1. Sealing	CR	Visual & Meas	One length of each size	One length of each size	Min. area of coverage of armouring shall be 90%. The gap between armour wires / formed wires shall not exceed one armour wire/formed wire space & there shall be no cross over/over riding of armour wire / formed wire. Za rich paint shall be applied on armour joint surface of G.S. Wire /formed wire		--do--	P	W	W	
4-01	Identification	NTPC Sealing	MA	Visual	100%	100%	(1) IS1554 (Part-1) & IS 7098-Part 1 (2) The surface of the drum and the outer most cable layer shall be covered with water proof cover (3) Both the ends of cables shall be properly sealed with heat shrinkable PVC/ rubber caps secured by "U" nails.		QCR	P	--	--	
			MA	Visual	100%	100%	Sealing shall be visible		QCR	P	V	V	

Sl. No	Component & Operations	Characteristics	Class	Type of check	Quantum of check		Reference Document	Acceptance Norms	Record Format	Agency	Remarks
					M	C/N					
1	2	3	4	5	6	7	8	9	10	11	

**Item: 1.1 KV Power (XLPE & PVC) Insulated FRLS cables**

**STANDARD QUALITY PLAN**  
(CONFORMING TO CODE: IS 1554 PART I, IS 7098 Part-I AND NTPC TECHNICAL SPECIFICATION)

QP. NO. 0000-999-QOE-S-041  
REV-01 DATE: \_\_\_\_\_  
Page 9 of 9

REVIEWED BY  
AMAN PANDEY  
RAJESH SHARMA  
S K LAL  
DINESH KUMAR

APPROVED BY  
K K OJHA

**Notes:**

- 1) If the compound manufacturer is carrying out Ageing test, test report of compound manufacturer is to be reviewed. If the compound manufacturer is not carrying out ageing test, then cable manufacturer is to carry out ageing test & test report is to be reviewed ( quantum of ageing test sample shall be one sample /batch)
- 2) 2(a) **In case of manufacturers / supplier who have supplied cables in the past through Corporate Centre:-** Routine Test of manufacturer internal test report are to be verified by NTPC at the time of final inspection.  
2(b) **In case of manufacturers / supplier WHO HAVE NOT SUPPLIED cables in the past through Corporate Centre:-** Routine Test are to be witnessed by Main Contractor on 100% basis. This is in addition to manufacturer internal test report to be verified by NTPC at the time of final inspection. Same is to be verified by NTPC
- 3)
  1. For Smoke Density rating test: if the test result without conditioning is within (-)10% of the maximum specified value, then, retesting is to be carried out with conditioning of samples as per standard and the test results after conditioning shall be final for acceptance/rejection.
  2. For Acid Gas Generation test: if the test result without conditioning is within (-)10% of the maximum specified value, then, retesting is to be carried out with conditioning of samples as per standard and the test results after conditioning shall be final for acceptance/rejection.
  3. For Oxygen Index test: if the test result without conditioning is within (+)7% of the minimum specified value, then, retesting is to be carried out with conditioning of samples as per standard and the test results after conditioning shall be final for acceptance/rejection.
  4. In case the test results without conditioning donot meet the maximum/minimum specified value, the manufacturer may exercise the option of retesting the samples after conditioning as per standard.
- 4) For PVC insulated LT power cable :- For cables with OD less than equal to 30 mm, any size of cable may be clubbed together . For cables where OD is more than 30 mm, clubbing to be done for cables having similar ODs.  
For XLPE insulated LT Power cable: Clubbing to be done for cables having similar ODs.

**LEGEND:** NTPC ADS: NTPC approved data sheet, QCR: quality control records of cable manufacturer, CABLE MANUIE  
STD- cable manufacturer's internal plant standard, MI: minor, MA: major, CR: critical,  
COC- certificate of conformance



LEGEND:- \*RECORDS, IDENTIFIED WITH "TICK" UNDER COLUMN "D" SHALL BE ESSENTIALLY INCLUDED BY SUPPLIER IN QA DOCUMENTATION.  
-M:MANUFACTURER/SUPPLIER, C:MAIN SUPPLIER, N:NTPC, P:PERFORM W:WITNESS, V:VERIFICATION AS APPROPRIATE, CHIP: NTPC SHALL IDENTIFY IN COLUMN "N" AS "W"  
FORMAT NO:QS-01-QAI-P-10/F3-RI

ITEM : (MATERIAL, CLASS, GRADE, RATING, SIZE ETC.)		STANDARD QUALITY PLAN										REVIEWED BY		APPROVED BY	
		Q.P. No. : 0000-995-QQE-S-034	REV. : 01	DTD: 15/03/04	PAGE 1 OF 3	VALID UPTO : 14.03.07	ACCEPTANCE NORMS	REFERENCE DOCUMENT	QUANTUM OF CHECK	TYPE OF CHECK	CLASS	CHARACTERISTICS	COMPONENT & OPERATIONS	SL. NO.	REMARKS
DISTRIBUTION BOARDS		7	6	5	4	3	2	1	8	9	10	11			
		7	6	5	4	3	2	1	8	9	10	11			
1	Lighting Panels & Lighting Distribution Boards Final Inspection and Testing	a) Overall Dimensions	MA	Meas.	100%	One Panel/Type/lot	NTPC/Main supplier Appd. Drg / data sheet	Inspt Report	P	W	W				
		b) Thickness of sheet	MA	Meas.	100%	--DO--	--DO--	--DO--	P	W	W				
		c) Paint shade	MA	Visual	100%	--DO--	--DO--	--DO--	P	W	W				
		d) Thickness of paint	MA	Meas	100% of items	Min. 5 points/Panel	--DO--	--DO--	P	W	W				
		e) Surface finish	MA	Visual	100%	Panel	Smooth, without lump	--DO--	P	W	W				
		f) Adhesion Test	MA	Mech.	One sample/lot/size	One	Should not peel off	--DO--	P	W	W				
		g) Name Plate	MA	Visual	100%	10% of each type	NTPC/Main supplier Appd drg/ data sheet	--DO--	P	W	W				
		h) Tightness of bus bar bolts	MA	Mech	100%	One Panel/Type/lot	Manufacturer Std.	--DO--	P	W	W				
		i) Bus Bar Clearance	MA	Meas.	100%	--DO--	NTPC/Main supplier Appd drg /data sheet	--DO--	P	W	W				

LEGEND: RECORDS IDENTIFIED WITH "TICK" SHALL BE ESSENTIALLY INCLUDED BY THE CONTRACTOR IN QA DOCUMENTATION  
 \*\* M. MANUFACTURER/SUB-SUPPLIER, C.CONTRACTOR/NOMINATED INSPECTION AGENCY (SUBJECT TO PRIOR APPROVAL OF NTPC), N. NTPC, INDICATE "P" PERFORM, "W" WITNESS AND "V" VERIFICATION AS APPROPRIATE  
 "CHK" BY NTPC SHALL BE IDENTIFIED IN COLUMN "N" AS "W".  
 FORMAT -QS-01-QALP-10/F1-R0  
 ENGINEERING DIV./QA&I



**CABLING**

ATTRIBUTES / CHARACTERISTICS  ITEMS/COMPONENTS / SUB SYSTEMS	Dimension	Paint shade, paint thickness, adhesion	Pre-treatment of sheet	IP protection	Proof load*	Surface finish	Deflection test*	HV & IR	Galvanise Test (If Applicable)	Functional	Bought out items/Bill of material	Routine tests as per relevant standard & specification	Acceptance tests as per relevant standard & specification	Constructional feature as per NTPC Specification
Wall Mounted- Panel (IS-513, IS:5, IS:2629, 2633, 6745)	Y	Y	Y	Y		Y		Y		Y	Y	Y	Y	Y
Cable glands(BS-6121)	Y													Y
Cable lug	Y													Y
Flexible conduits	Y											Y		Y
Conduits (Galvanise & Epoxy) IS-9537 & IS-2629, 2633, 6745	Y		Y						Y			Y		Y
Cable Trays, bends, tees, crosses, Flexible supports system & accessories IS-513, 2629,2633,6745	Y		Y		Y	Y	Y		Y			Y	Y	Y

.Note:1.This is an indicative list of tests /checks. The manufacturer is to furnish a detailed Quality Plan indicating the practice and procedure along with relevant supporting documents.  
 2.\* Deflection Test on cable trays and Proof Load test on cable trays support system will be as per details given in the NTPC technical specification & approved MQP. The above acceptance tests shall be done only on one sample from each size of offered lot. This test is not applicable on bends, tees & crosses.  
 3. Make of all items will be subject to NTPC approval.

**Electrical scope sheet for Scope between BHEL & Vendor- Kahalgaon R&M project  
(HVAC System)**

S.NO	DETAILS	SCOPE SUPPLY	SCOPE E&C	REMARKS
1	AC fuse DB	Vendor	Vendor	Feeders for all the electrical equipment in scope of bidder shall be provided in the AC fuse DB. Minimum 8 nos. Fuse DBs (total) shall be provided to cater to the load requirements of the HVAC plant. Incoming supply cable upto AC fuse DB is in BHEL scope.
2a	Local Push Button Station (for motors)	Vendor	Vendor	Located near the motor.
2b	Local motor starters	Vendor	Vendor	Local motor starters shall be provided for all supply and exhaust fans.
3	Power cables, control cables and screened control cables for a) both end equipment in BHEL's scope b) both end equipment in vendor's scope c) one end equipment in vendor's scope	BHEL Vendor BHEL	BHEL Vendor BHEL	1. Sizes and quantity of cables required shall be informed by vendor at contract stage (based on inputs provided by BHEL). Finalisation of cable sizes shall be done by BHEL. Vendor shall provide lugs & glands accordingly. 2. Laying of cables by BHEL except for cabling in vendor scope. 3. Termination at BHEL equipment terminals by BHEL. 4. Termination at Vendor equipment terminals by Vendor.
4	Any special type of cable like compensating, co-axial, prefab, MICC, fibre optical etc. Conduit for FO cables	Vendor	Vendor	
5	Cable trays, accessories & cable trays supporting system (Main route)	BHEL	BHEL	
6	Cable glands and lugs for equipment supplied by Vendor	Vendor	Vendor	1. Double compression Ni-Cr plated brass cable glands

S.NO	DETAILS	SCOPE SUPPLY	SCOPE E&C	REMARKS
				2. Solder less crimping type heavy duty tinned copper lugs for power cables 3. Solder less crimping type heavy duty copper lugs for control cables.
7	Conduit and conduit accessories for cabling between equipment supplied by vendor 100/ 50 mm cable trays/ Conduits/ Galvanised steel cable troughs for local cabling	Vendor	Vendor	Conduits shall be medium duty, hot dip galvanised cold rolled mild steel rigid conduit as per IS: 9537. Makes of conduits shall be subject to customer/ BHEL approval at contract stage. **
8	Lighting	BHEL	BHEL	
9	Equipment grounding & lightning protection	BHEL	BHEL	
10	Below grade grounding	BHEL	BHEL	
11	LT Motors with base plate and foundation hardware	Vendor	Vendor	Makes shall be subject to customer/ BHEL approval at contract stage.
12	Mandatory spares	Vendor	-	Vendor to quote as per specification.
13	Recommended O & M spares, E & C spares, erection & maintenance tools & tackle.	Vendor	-	As per specification
14	Any other equipment/material/service required for completeness of system but not specified above (to ensure trouble free and efficient operation of the system).	Vendor	Vendor	
15	a) Input cable schedules (C & I) b) Cable interconnection details for above c) Cable block diagram	Vendor Vendor	- -	Cable listing for C & I systems for vendor supplied equipment shall be furnished during detail engineering by vendor in soft copies in the BHEL cable schedule format.

Local cabling from nearby main route cable tray (BHEL scope) to equipment terminal (vendor's scope) shall be through 100/ 50 mm. cable trays/ conduits/ Galvanised steel cable troughs, as per approved layout drawing during contract stage. Conduits/tray/trough also to be provided wherever cable tray route is not available at site.

\*\*

S.NO	DETAILS	SCOPE SUPPLY	SCOPE E&C	REMARKS
		Vendor	-	
16	Equipment layout drawings	Vendor	-	For ensuring cabling requirements are met, vendor shall furnish layout drawings (both in print form as well as in AUTOCAD) of the complete plant (including electrical area) indicating location and identification of all equipment requiring cabling, and shall incorporate cable trays routing details marked on the drawing as per PEM interface comments. Electrical equipment layout drawing shall be to BHEL approval.
17	Electrical Equipment GA drawing	Vendor	-	For necessary interface review.
18	Junction Boxes	Vendor	Vendor	Junction boxes shall be used to minimize/optimize the runs of cables between equipment

**NOTES:**

1. Make of all electrical equipment/items supplied shall be reputed make & shall be subject to approval of BHEL/customer after award of contract.
2. All QPs shall be subject to approval of BHEL/customer after award of contract without any commercial implication.

	TITLE	SPECIFICATION NO.
	<b>MOTOR</b>  <b>DATA SHEET - C</b>	VOLUME II B
		SECTION D
		REV NO.00 DATE
		SHEET 1 OF 2

S. No.	Description	Data to be filled by successful bidder
<b>A.</b>	<b>General</b>	
1	Manufacturer & country of origin	
2	Motor type	
3	Type of starting	
4	Name of the equipment driven by motor & Quantity	
5	Maximum Power requirement of driven equipment	
6	Rated speed of Driven Equipment	
7	Design ambient temperature	
<b>B.</b>	<b>Design and Performance Data</b>	
1	Frame size & type designation	
2	Type of duty	
3	Rated Voltage	
4	Permissible variation for	
5	a) Voltage	
6	b) Frequency	
7	c) Combined voltage & frequency	
8	Rated output at design ambient temp (by resistance method)	
9	Synchronous speed & Rated slip	
10	Minimum permissible starting voltage	
11	Starting time in sec with mechanism coupled	
12	a) At rated voltage	
13	b) At min starting voltage	
14	Locked rotor current as percentage of FLC (including IS tolerance)	
15	Torque	
	a) Starting	
	b) Maximum	
16	Permissible temp rise at rated output over ambient temp & method	
17	Noise level at 1.0 m (dB)	
18	Amplitude of vibration	
19	Efficiency & P.F. at rated voltage & frequency	
	a) At 100% load	
	c) At 75% load	

NAME OF VENDOR			SEAL	REV.	
NAME	SIGNATURE	DATE			

	TITLE	SPECIFICATION NO.
	<b>MOTOR</b>  <b>DATA SHEET - C</b>	VOLUME II B
		SECTION D
		REV NO.00 DATE
		SHEET 2 OF 2

S. No.	Description	Data to be filled by successful bidder
	c) At starting	
<b>C.</b>	<b>Constructional Features</b>	
1	Method of connection of motor driven equipment	
2	Applicable Standard	
3	DOP of Enclosure	
4	Method of cooling	
5	Class of insulation	
6	Main terminal box	
	a) Type	
	b) Power Cable details (Conductor, size, armour/unarmour)	
	c) Cable Gland & lugs details (Size, type & material)	
	d) Permissible Fault level ( kArms & duration in sec)	
7	Space heater details (Voltage & watts)	
8	Flame proof motor details (if applicable)	
	a) Enclosure	
	b) suitability for hazardous area	
	i Zone	O / I / II
	ii Group	IIA / IIB / IIC
9	No. of Stator winding	
10	Winding connection	
11	Kind of rotor winding	
12	Kind of bearings	
13	Direction of rotation when viewed from NDE	
14	Paint Shade & type	
15	Net weight of motor	
16	Outline mounting drawing No (To be enclosed as annexure)	
<b>D.</b>	<b>Characteristic curves/ drawings</b> (To be enclosed for motors of rating $\geq 55KW$ )	
	a) Torque speed characteristic	
	b) Thermal withstand characteristic	
	c) Current vs time	
	d) Speed vs time	

NAME OF VENDOR			SEAL	REV.	
NAME	SIGNATURE	DATE			



**KAHALGAON STPS (R&M) STAGE-I  
(4x210MW)  
HVAC SYSTEM**

SPECIFICATION No: PE-TS-491- (571-13000-  
A)-A002 (REV-0)

**SECTION : I**

**SUB-SECTION : D**

**REV. 00**

**SECTION: I**

**SUB-SECTION: D**

**STANDARD TECHNICAL SPECIFICATIONS**



TITLE

## Ventilation Fan (Axial Flow Type)

### DATA SHEET - A

SPECIFICATION NO. PE-FC-0001/1-10000/A001

VOLUME

SECTION

REV 00

DATE APRIL 2015

SHEET 1 OF 2

No.	Particulars	Data
<b><u>General Information</u></b>		
1)	Designation	Supply/Exhaust Fans.
2)	Nos. required	Refer schedule of Ventilation system in section-1A under specific technical requirement.
3)	Service	To exhaust warm air/to supply fresh air.
4)	Location	Wall mounted.
5)	Area	Same as above in 2.
<b><u>Design Data</u></b>		
6)	Type supply	Axial fans suitable for 415V/3 phase for Motor.
7)	Air delivery capacity	As per schedule of ventilation system.
8)	Fluid	Atmospheric Air.
9)	Temperature	Refer Section of specific technical requirement
10)	Static Pressure required	As per specification schedule of ventilation system.
11)	Outlet Air Velocity	Not more than 12 m/sec.
<b><u>Materials</u></b>		
12)	Casing	M.S.
13)	Impeller	Cast Aluminium. (Alloy A-6M,)
14)	Hub	Al Alloy.
15)	Support frame and structure.	M.S. of adequate thickness (Galvanized/ Painted).
16)	Neoprene rubber pads	As required.
17)	Coned inlet for wall exhausters/supply fans	MS
18)	Supporting frame for mounting.	Required.
19)	Protective screen at inlet.	Yes (Min 14 SWG Galvanized wire knitted in 1" square mesh.
20)	Rain Protection Cowl	Aluminum or hot dip Galvanized after fabrication from M.S.



TITLE	<b>Ventilation Fan (Axial Flow Type)</b> <b><u>DATA SHEET - A</u></b>		SPECIFICATION NO: PE-FC-355 BY 1-150004-A001	
			VOLUME	
			SECTION	
			REV 00	DATE APRIL 2015
			SHEET 2 OF 2	

**Motor**

- |                |        |
|----------------|--------|
| 21) Motor by   | Bidder |
| 22) Starter by | BHEL   |

**NOTE:**

- 1) For Battery Room, motor for fan shall be of flame proof type & fan of spark proof construction with Epoxy painting.
- 2) Gravity type damper shall be provided at the outlet of axial fan for exhaust application.
- 3) Motor shall have 15% margin over Duty Point.



## TECHNICAL SPECIFICATION

### VENTILATION FANS

PROJECT: \_\_\_\_\_  
DRAWING NO: \_\_\_\_\_  
SECTION: \_\_\_\_\_  
REV. NO: \_\_\_\_\_ DATE: NOV 2012  
SHEET NO: \_\_\_\_\_

#### 1. GENERAL

This specification covers the design, manufacture, testing of performance at manufacturer's/sub-contractors works, delivery at site, handling at site, erection and commissioning of ventilation fans.

#### 2. CODE AND STANDARDS

The design, manufacture and performance of equipment shall comply with all currently applicable statutes, regulations and safety codes in the locality where it is to be installed. The equipment shall conform to latest edition of applicable Indian Standards or their equivalent standards. Nothing in this specification shall be construed to relieve the vendor of this responsibility. In particular the equipment shall conform to the latest editions of the Following standards.

- 2.1.1 BS:848 -Method of performance test for fans.
- 2.1.2 AMCA publication 99 standards handbook
- 2.1.3 AMCA standard 210, Test code for air moving devices.

#### 3. DESIGN AND CONSTRUCTION

##### 3.1 THE ENCLOSED DATA SHEET A GIVES THE NECESSARY DETAILS FOR CENTRIFUGAL/AXIAL/ROOF EXTRACTOR UNITS ETC.

##### 3.2 WELDING PROCESS AND WELDERS EMPLOYED FOR FABRICATION SHALL BE QUALIFIED AS PER ASME SEC. IX

##### 3.3 CASING

3.3.1 The centrifugal fans casing shall be of welded construction fabricated with heavy gauge material (min 3 mm) with flanges (min. 5 mm) on inlet and out let side for direct connection and shall be rigidly reinforced and supported by structural angles. The seams shall be permanently sealed airtight. Horizontal Split casings shall be provided on large size fans. Casing drain (at bottom) with threaded plug/ with valve shall be provided, as required. All mounting/ connecting holes shall be drilled off centre.

3.3.2 The axial flow casing for supply fans/roof extractors shall be of heavy gauge construction (min 3 mm) properly reinforced for rigidity and shall be complete with suitable supports. Access doors with suitable locking arrangement shall be provided in the casing for easy access to the motor and impeller. External junction box/ Terminal box on casing with IP-55 protection shall be provided, if required. Wiring for motor from external junction box/ Terminal box shall be through flexible conduit.

3.3.3 Suitable motor brackets designed for rigid mounting of motors, shall be provided for roof extractors and wall mounted exhaust/ supply fans.

##### 3.4 IMPELLER

3.4.1 Centrifugal fan impeller shall have die formed, aerofoil or laminar blades welded to the rim and back plate and shall have non-overloading, self cleaning characteristics. Rim shall be spun to have smooth contour. If required, intermediate stiffening rings shall be provided. Shaft sleeves shall be furnished, if specified. The impeller, pulley and shaft sleeve shall be secured to the shaft by key and/or nuts (threaded opposite to direction of rotation of impeller). The impeller shall be statically and dynamically balanced.

~~3.4.2~~ The axial fan impeller shall be of high efficiency aerofoil design. The blades shall be mounted on a streamlined hub and the impeller shall be mounted directly on the



## TECHNICAL SPECIFICATION

### VENTILATION FANS

motor shaft. Impeller shall be in one piece however; fabricated blades will be acceptable up to 450 mm impeller diameter.

- 3.4.3 Roof ventilator impeller may either be centrifugal or axial type. Backward inclined blades shall be provided for centrifugal impellers. Blades may be die-formed or cast. Axial flow impeller shall be directly mounted to motor shaft whereas centrifugal impeller may either be direct-driven or belt-driven. The shaft of belt-driven centrifugal fan shall be solid cold rolled carbon steel, ground and polished. However, direct mounted impellers are preferred.

#### 3.5 BEARINGS:

- 3.5.1 The centrifugal fan bearing may be ball, roller or sleeve bearings of self-aligning heavy duty type with adequate capacity and life. Make of Bearings to be specified. Bearings shall be oil/grease lubricated and provided with fittings for lubrication from outside and shall be located in easily accessible position to facilitate maintenance.

#### 3.6 INLET CONES AND GUARDS

- 3.6.1 Centrifugal fans inlet shall be spun to have a smooth contour. Inlet screen, if provided, shall be galvanised wire mesh of 25 mm square with wire thickness of min. 1.5 mm.
- 3.6.2 Inlet cone, outlet bell and suitably designed guards shall be provided.

#### 3.7 GUIDE VANES:

- 3.7.1 In case of vane axial fans guide vanes shall be provided on discharge side.

#### 3.8 BASE PLATE AND VIBRATION ISOLATORS

- 3.8.1 Base plate and vibration isolators, which may be double deflection rubber in shear or rubber in compression type or spring type shall be provided. With each fan rubber bushes, washers wherever needed for vibration isolator in sufficient nos. shall be included, as required, to ensure isolation of foundation from vibration of equipment. For roof ventilators suitable mounting arrangement shall be provided such that there is no ingress of rain water into the building.

#### 3.9 HOOD AND COWL

- 3.9.1 Roof exhaustors shall be provided with hinge type hood providing easy access to motor and impeller. Weather proof lockable type disconnect switch shall be provided such that hood can open only when the disconnect switch is in 'off' position. On larger size of roof ventilators hoods may be of split construction. 15 mm mesh galvanised bird screen shall be provided.
- 3.9.2 Rain protection cowls shall be designed to suit wall exhaustors/supply fans for protecting fans from rain. The cowls shall be provided with bird screen of heavy gauge expanded metal netting.

#### 3.10 SPEED

- 3.10.1 The speed of axial flow fans/roof ventilators shall not exceed 960 RPM for impeller dia exceeding 450 mm and shall not be greater than 1440 with impeller dia less than 450 mm.

#### 4. MOTORS

Drive motors shall be of totally enclosed type, suitable for horizontal/vertical mounting as applicable and shall comply with the requirements of the specifications furnished elsewhere for motors.



## TECHNICAL SPECIFICATION

### VENTILATION FANS

SPECIFICATION NO. PHS-SSLD3

VOLUME

SECTION

REV. 02

DATE: NOV 2012

PAGE 4 OF 4

#### 5. ACCESSORIES

Accessories as specified in Data sheet-A and as required for satisfactory trouble free & safe operation of fans shall be provided.

#### TESTING AND INSPECTION

List of TCs arranged as per Approved Quality Plan shall be furnished along with copy of TCs at the time of inspection by BHEL

- Visual inspection of sheets/plates, angles, channels etc. – Pitting, lamination in sheets/ plates, angles and channels shall be avoided.- visual inspection by main contractor of BHEL.
- Sheets/ Plates - Test certificate shall be furnished for physical and chemical properties for sheets / plates- for review by BHEL
- Shaft Mechanical and chemical-- review by BHEL
- Motors (of approved make): Routine TC ,FLP TC if applicable
- Workmanship and dimensional check as per manufacturing drg. and approved Drgs.- by main contractor of BHEL.- Shall be checked by BHEL/ Customer during final inspection.
- Balancing of impellers- Dynamic balancing certificates shall be furnished –grade 6.3 or better to ISO-1940. Balancing weights shall be positively locked/ welded to avoid loosening. - witness by manufacturer - TC to be furnished for review by BHEL(consisting of weight of impeller, radius of correction and balancing rpm). For spare impellers Dynamic Balancing shall be witnessed by BHEL.
- Performance test of one Centrifugal fan or Axial Fan /per type/per size as per applicable standard – by BHEL.
- Centrifugal/ Axial fans 100% run tested by main contractor of BHEL. Run test by BHEL/Customer may be at random or 100%- Vibration shall be within satisfactory zone of VDI 2056 (group- G ) machines when measured on bearing housing and noise level <85 dbA at 1 metre distance. Max. Temp. on bearing housing- 40 degrees Centigrade + ambient



TITLE

**LOW PRESSURE AIR DISTRIBUTION SYSTEM****DATA SHEET - A**

SPECIFICATION REFERENCE: IFCM-1400

VOLUME

SECTION

REV: 00

DATE: APRIL 2015

SHEET NO. 1 OF 1

**Description****Data**

- |   |   |
|---|---|
| 1. General (List of areas)  | : As per Specification/Tender drawing.  |
| 2. GSS Duct Work<br>a) Type<br>Requirements.)<br><br>b) Size  | : GSS as per<br>(Zinc coating as per Specific Technical<br><br>: As per Specific Technical<br>Requirements and bill of quantity.              |
| 3. Acoustic lining<br>AC Outlet.  | : Up to 3-5m length from Ductable Split   |
| 4. Special painting   | : Galvanised.   |
| 5. Thermal Insulation   | : Required in supply/ return air duct in AC<br>entire length.   |
| 6. Diffusers (Circular/Square)<br>300 mm size<br>350 mm size<br>450 mm size<br>550 mm size<br>600 mm size<br>Any other size | : Bidder to estimate as per<br>drawings./specification.<br>All grille frame and louvers shall be<br>manufactured of at least 16 SWG Aluminium |
| 7. SA grilles (for each size)   | : To suit air flow as per System<br>requirements / Tender Drawings.   |
| 8. RA grilles (for each size)   | : -do-  |

**NOTE:**

1. Duct sheet thickness shall be as per BIS/SMACNA
2. Opposed blade type volume control damper shall be provided at each supply air diffusers/grilles.
3. Bidder to provide suitable gasketing at each duct flange.
4. Fire damper shall be motor operated type, when otherwise specified under Section-1A.
5. Access door in ducting system shall be provided as required.
6. MS Angle (painted) shall be used for duct supports etc.
7. Velocity thru duct shall normally not exceed 9.0 M/sec for Air conditioning system. Maximum velocity (outlet) for supply air diffuser shall not exceed 2.5 m/sec.
8. All Grilles & diffusers shall be supported with frame. Frame etc. shall be supplied by bidder.



**TECHNICAL SPECIFICATION**  
**LOW PRESSURE AIR DISTRIBUTION**  
**SYSTEM**

REVISION FOR NAME/SUBJECT
ISSUE NO.
SECTION
REV. DATE
DATE

**1. GENERAL**

1.1 This specification covers the design, manufacture, construction features, installation, inspection testing and air balancing of air distribution system upto a total pressure of 95mm w.g. The specification is intended to cover the air distribution for air conditioning system not involving localised exhaust.

**2. CODES AND STANDARDS**

2.1 The design, construction and performance of complete system shall conform to all currently applicable statutes, regulations, safety codes in the locality where the equipment are to installed

2.2 Unless specified otherwise the equipments shall generally conform to latest applicable Indian Standards. Nothing in this specification shall be construed to relieve the vendor of this responsibility. In particular the equipment shall generally conform to latest editions by the SMACNA standards:-

**3. MATERIAL**

3.1 Metal air ducts shall be either of galvanised steel sheets or aluminium sheets, as indicated in data sheet-A.

3.2 The rolled steel sheets before galvanising shall be properly annealed or normalised so as to allow fabrication of ducts without developing cracks. Zinc coating on the steel shall be as per technical requirement refer to Specific Technical Requirements.

3.3 The aluminium sheets shall be of grade S1C or NS3 and shall be suitable for duct fabrication work.

**4. CONSTRUCTION/FABRICATION: AS PER SMACNA**

**4.1 DUCT SUPPORTS**

Unless specified otherwise on drawings, rectangular ducts with larger side of 2250mm or above shall be supported by 15mm MS rods and 50x50x3mm and MS angles while those below 2250 mm shall be supported by 10mm MS rods and all angles shall be given a coat of primer paint. The duct supports shall be at a distance not exceeding 1800mm. The MS rods shall be fixed to MS angle cleats, which in turn are fixed to ceiling slab by suitable anchor fasteners. All anchor fasteners, MS angle cleats, coach screws, hooks and other supporting material required shall be provided by vendor.

However, If ducts are thermally insulated, the MS angles and supports shall not be in direct contact with ducts, for which purpose wooden pieces/ Resin bonded fibre glass sheets (50 mm thick) shall be used in between.

**4.2 FLEXIBLE CONNECTIONS**

Wherever the sheet metal ducts connects to intake or discharge of fan units a flexible connection of at least 150mm width made by closely woven double layer Fire resistant or canvas shall be provided. The same shall be attached to angle iron frames on equipment and to similar frame on duct or casing by means of a steel band 9r (or) collar fitting over the end of the flexible connection and bolted through angle iron frame so as to clamp securely between the band and the angle frame.



## TECHNICAL SPECIFICATION

### LOW PRESSURE AIR DISTRIBUTION SYSTEM

- 4.3 TRANSFORMATIONS AND BREACHES**
- All curves, bends, offsets and other transformations shall be made for easy and noiseless flow of air. The throat of every branch duct shall be sized to have a velocity not exceeding that in the main duct to which the branch is connected.
- 4.4 CAULKING**
- Wherever duct passes through wall, the opening between masonry and duct work shall be neatly caulked or sealed to prevent movement of air from one space to adjoin by space with a rated fire resistant material.
- 4.5 EASEMENT**
- Normally pipe hangers, light fitting rods etc. shall not be allowed to pass through the ducts. Wherever, It becomes absolutely essential to pass these hangers/rods etc. Through the ducts, prior approval of purchaser shall be taken and light streamlines easement around the same shall be provided to maintain smooth air flow.
- 4.6 ACCESS DOORS**
- Access doors shall be provided in ducts, plenums etc. on both sides to allow access and servicing of equipment viz. pipes, dampers, coils, valves, heaters etc.
- All access doors shall be adequately sized and lined suitably with felt to prevent air leakage. The doors shall be of built-up construction, structurally strong and shall have at least two hinges each, and shall be with two rust proof window sash locks of approved type. All doors shall be so set as to flush with outer finish of duct insulation etc.
- 4.7 DAMPERS AND SPLITTERS**
- 4.7.1** Dampers and splitters shall be provided at suitable points for proportional volume control of the system. Splitters and dampers shall be made of minimum 18 gauge GSS of quadrant type with locking device mounted outside the duct at accessible location.
- 4.7.2 FIRE DAMPERS**
- Fire dampers shall be provided as specified in Data Sheet -A and shall be installed at locations indicated on drawings and/or as required/approved by purchaser, including all openings in passage of duct work through fire walls and floors etc. The fire damper shall be of electrical type with damper motor actuated by thermal sensor or fusible link type.
- 4.7.3 VANES**
- Unless otherwise shown in the drawings all elbows shall be such that the throat radius is 75% of the duct width. In case throat radius is smaller, suitable single thickness vanes of approved details shall be provided.
- 4.7.4 FLASHING**
- For the ducts penetrating roofs or outside walls, provision of flashing shall be made by the ducting vendor.
- 4.8 DIFFUSERS AND GRILLS**
- The type and quantity of diffusers and grills is indicated on enclosed drawings/data sheet A. The size/quantity of diffusers/ grills indicated in the drawing/data sheet is indicative and is for vendor's reference purpose only. Vendor shall ensure that the diffusers/grills offered are of requisite capacity, throw and terminal velocity. The pressure drop and noise levels shall be as per data sheet. A enclosed. The



## TECHNICAL SPECIFICATION

### LOW PRESSURE AIR DISTRIBUTION SYSTEM

diffusers/grills shall be approved by purchaser.

Unless specified otherwise the diffusers/grills shall be of mild steel land painted with two coats of primer paint. Supply air grills shall be complete with volume control dampers. Supply air grills shall be double deflection type while Return Air grills can be single deflection type. Ceiling outlets/diffusers shall have volume control dampers, fixed grids and blanking baffles. All volume control dampers shall be operated by a key from the front of grills/diffusers.

Suitable vanes shall be provided in duct collars to have uniform air distribution. Blank-off baffles wherever required, shall also be provided.

#### 4.9 PLENUMS AND RA BOXING

All plenum chambers and/or connections to fans, dampers etc. shall be constructed in 18 gauge GI sheet. supported on 40x40x6mm MS angle frames. All vertical angles shall be riveted at approx. 125mm. centres to the casing. Suitable caulking compound (Pecora or equivalent) shall be inserted between the base of the angle and all masonry construction to which angles are fastened.

Return air boxing requirements if any are indicated in data sheet-A and the same shall be provided by vendor. The return air box shall be fabricated out of GI sheets shall be insulated with 25mm thick fibre-glass.

#### 4.10 ACCOUSTIC LINING

The ducts shall be lined acoustically from inside as given in data- sheet A and/or section 1A of the specification.

#### 4.11 PAINTING

Wherever specified the ducts shall be painted or lined with suitable anti-corrosive paint/ lining as per approval of purchaser. In particular the ducts coming in contact with acid fumes shall be epoxy coated, inside and outside.

#### 4.12 THERMAL INSULATION

Thermal insulation shall be as per data sheet - A and the insulation shall conform to enclosed spec. no. PES-553-08.

### 5. INSPECTION AND TESTING

#### 5.1 INSPECTION & TESTING DURING FABRICATION

5.1.1 Visual inspection of GI sheets and angles, channels etc. – dents, black spots, chipping of zinc coating, white dust on galvanised sheets shall be avoided. Pitting , lamination in angles and channels shall be avoided.

5.1.2 Galvanised sheets - Test certificate shall be furnished for visual check, coating thickness, adhesion test, sheet thickness, uniformity of coating.

5.1.3 Check for dimensions & mass as per latest standard.

5.1.4 Check for defect, twists, ungalvanised spots as per latest standard.

5.1.5 Bend test & wrapping test as per latest standard.

5.1.6 Zinc coating test on samples as per latest standard.

#### 5.2 INSPECTION & TESTING AT SITE.

5.2.1 The duct branches, elbows etc. shall be inspected and the joints and connections etc, are to be checked before they are assembled in position.



**TECHNICAL SPECIFICATION**  
**LOW PRESSURE AIR DISTRIBUTION**  
**SYSTEM**

SPECIFICATION NO. PES-SS-17  
VOLUME  
SECTION  
REV. DATE  
SHEET 5 OF 6

5.2.2 After completion, all duct systems shall be checked and tested for air leakage, tightness, velocity, pressure drop, vibration and noise etc.

**6. BALANCING**

6.1.1 The entire air distribution system shall be balanced by vendor to supply the air quantities as required in various rooms so as to maintain the requisite temperature and air flow in the conditioned spaces. The final balance of air quantities through each grill/diffuser etc. shall be recorded and submitted to purchaser for approval. Proper steps shall be taken to have a uniform temperature in all enclosures, with utmost care for noise level to be within tolerance limit

6.1.2 All instruments required for testing/balancing etc. of the air distribution system shall be provided by vendor.



**KAHALGAON STPS (R&M) STAGE-I  
(4x210MW)  
HVAC SYSTEM  
LIST OF MAKES**

**SPECIFICATION No: PE-TS-455-571- 15000A-  
A002**

**SECTION : I**

**SUB-SECTION : E**

**REV 00**

**SECTION-I  
SUB SECTION -E**

**ANNEXURE-I**

**LIST OF MAKES OF SUB-VENDOR ITEMS**



**KAHALGAON STPS (R&M) STAGE-I  
(4x210MW)  
HVAC SYSTEM  
LIST OF MAKES**

**SPECIFICATION No: PE-TS-455-571- 15000A-A002**

**SECTION : I**

**SUB-SECTION : E**

**REV 00**

<b>SL. No</b>	<b>ITEM</b>	<b>VENDOR</b>
1	SPLIT AIR CONDITIONER	VOLTAS
		BLUE STAR
		CARRIER
		HITACHI-HIREL
		LG
4	FRESH AIR/ SUPPLY/ EXHAUST/ RE UNIT FANS / PROPELLAR	HYDERABAD POLUTION CONTROL
		SK SYSTEM
		ADVANCE VENTILATION
		KRUGER
		NICOTRA
		MARATHON
		FLAKT
		CB DOCTOR
		SARLA (SITAL)
		PATEL AIR
		KHAITAN
6	LV MOTORS (FLAME PROOF)	SIEMENS
		ABB
		CGL
		MARATHON
		KEC
		BHARAT BIJLEE
		BHARAT ELECTRIC
		NGEF
		JYOTI
		LHP
		7
ABB		
CGL		
MARATHON		
KEC		
BHARAT BIJLEE		
BHARAT ELECTRIC		
NGEF		
JYOTI		
LHP		
8	AIR FILTER	
		FMI
		ANFILCO
		TENACITY



**KAHALGAON STPS (R&M) STAGE-I  
(4x210MW)  
HVAC SYSTEM  
LIST OF MAKES**

**SPECIFICATION No: PE-TS-455-571- 15000A-A002**

**SECTION : I**

**SUB-SECTION : E**

**REV 00**

		JOHN FOWLER
		SPECTRUM
		AIR TECH
		PUROMATIC
9	INSULTATION MATERIAL	BEARDSHEL
		K-FLEX
		PARAMONT
		ARMAFLEX
		SUPREME
		LLOYDS
		UP TWIGA
		AEROCELL
14	Pipes (MS/GI) - ERW	SURYA ROSHNI
		TISCO
		DADU PIPES
		INDUS TUBES
		WELSPUN
		TATA
		BST
		JINDAL
		SAIL
		PSL
		LALIT PROFILE
		SAMSHI PIPE INDUSTRIES
		S MUKUT PIPES
		MANN INDUSTRIES
		SURENDRA ENGINEERING
		PRATIBHA PIPES AND STRUCTURES PVT LTD
		JCO GAS PIPES
		NUKAT TANK AND VESSELS
		GOODLUCK TUBES
		ADVANCE STEEL TUBES
		BIHAR TUBES
		HITECH PIPES
		RATNAMANI
		MAHARASHTRA SEAMLESS
14	GI SHEETS FOR DUCTING	TISCO
		INDIAN IRON & STEEL CO
		RASHTRIYA ISPAT NIGAM LIMITED
		ESSAR
		ISPAT INDUSTRIES



**KAHALGAON STPS (R&M) STAGE-I  
(4x210MW)  
HVAC SYSTEM  
LIST OF MAKES**

**SPECIFICATION No: PE-TS-455-571- 15000A-A002**

**SECTION : I**

**SUB-SECTION : E**

**REV 00**

		JSW
		LLOYDS
		BHUSHAN STEELS
		TATA
		SAIL
		JINDAL
15	GRILL/DIFFUSER/VOLUME CONTROL DAMPER	AIR FLOW
		TSC
		AIR MASTER
		CARRYAIRE
		RAVISTAR (SYSTEM AIR )

**NOTES:**

1. \*Designed by Hyderabad Pollution Control / SK SYSTEM/ ADVANCE VENTILATION / DRAFT AIR/BLUE STAR/ VOLTAS/ STERLING WILSON/ROOTS COOLING SYSTEM/ C DOCTOR/ TAP/ Pack Plast/ Industrial projects and products & fabricated by their approved fabricator.

2. THE SUB VENDOR LIST ABOVE IS INDICATIVE ONLY AND IS SUBJECT TO BHEL APPROVAL DURING DETAILED ENGINEERING STAGE WITHOUT ANY COMMERCIAL & DELIVERY IMPLICATION TO BHEL. BIDDER TO PROPOSE SUB VENDOR WITHIN 4 WEEKS OF PLACEMENT OF LOI. THEREAFTER NO REQUEST FOR ADDITIONAL SUB-VENDOR SHALL BE ENTERTAINED.

3. THE INSPECTION CATEGORY WILL BE INTIMATED AFTER AWARD OF CONTRACT BY BHEL. HOWEVER, THE SAME WILL BE ADHERED BY THE BIDDER WITHOUT ANY COMMERCIAL AND DELIVERY IMPLICATION TO BHEL.





Project		KAHALGAON-II (4 x 210 MW)		STATUS OF ITEM REQUIRING QP& SUB-SUPPLIER APPROVAL		DOC NO. CS-4210-104(R&M)-2					
Package Contractor		R&M for ESP BHEL		ESP R&M - ELECTRICAL		REV. NO. : 0					
Contractor No.		CS-4210-104A(R&M)-2				DATE : 18.05.2017					
S.No	Item Services	QP/ Insp. Cat.	QP Sub. Schedule Approval schedule	Date of sub- mission	Date of commt Appl.	Status Code C/M	Proposed Sub-Supplier	Place of manufacturing works	Approval Status	Sub-supplier detail submission schedule	Remarks
1	HVTR SET (Power Plus)	II					NWL	USA	A		SUB QR ITEM
		II					Kraft Powercon	Sweden	A		SUB QR ITEM
2	HVR Transformer & EG Panel	I					ADOR Powertron	Pune	A		SUB QR ITEM
		I					Hind Rectifier	Mumbai	A*		* - TO BE CONSIDERED ONLY AFTER SATISFACTORY RESOLUTION OF HVR TRF FAILURE AT FGUTPP - SUB QR ITEM
		I					BHEL	Jhansi	A		SUB QR ITEM
		I					Kraft Powercon	Pune	DR		SUB QR ITEM
3	Oil Filled LT Transformer (5.6 / 415 KV)	I					EMCO	Thane / Jaigaon	A		SUB QR ITEM
		I					VOLTAMP	Makarapura	A		SUB QR ITEM
		I					Transformer & rectifier	Ahmedabad	A		SUB QR ITEM
		I					Kandhar	Menzul	A		SUB QR ITEM
		I					Tesla	Bhopal	A		SUB QR ITEM
		I					Kirloskar Electric	Pune	A		SUB QR ITEM
		I					Andrew Yulb	Chennai	A		SUB QR ITEM
		I					CGL	Malanpur	A		SUB QR ITEM
		I					ECE	Sonepat	A		SUB QR ITEM
		I					Vijay Electrical	Hyderabad	A		SUB QR ITEM
		I					Schneider	Naini/Vadodara	A		SUB QR ITEM
		I					Sudhir Intrevidyut	Bangalore	DR		SUB QR ITEM
4	LT Motor (See Note-1)	I					Jyoti	Vadodara	A		SUB QR ITEM
		I					Bharat Bijlee	Mumbai	A		UPTO 180 KW,RQP
		I					CGL	Ahmednagar	A		RQP
		I					ABB	Fardabad*/ Bangalore*	A		*UPTO 55 KW**ABOVE 55& UPTO 200 KW,RQP
		I					SIEMENS	Mumbai	A		RQP
		I					NGEF	Bangalore	A		UPTO 15 KW
		I					LHP	Solapur	A		UPTO 120 KW
		I					KEC	Bangalore/Hubli*	A		*UPTO 90 KW,RQP
		I					MARATHON	Calcutta	A		RQP
5	LT MCC /ACP	I					SCHEIDER	Nasik	A		
		I					L&T	Mumbai/Coimbatore	A		
		I					C&S	Noida/Haridwar	A		
		I					UNILEC	Gurgaon	A		
		I					GEI	Bangalore	A		
		I					SIEMENS	Mumbai	A		
		I					Control Schematics	Hyderabad	A		
		I					ABB	Bangalore	DR		
	DCDB, ACDB, MLDB, ACFFB, DCFB, LIGHTING PANEL, LOCAL CONTROL PANEL, (NON PLC), PB STATION, JB	I					Sources at SI No. 5 are also acceptable.				For lighting transformer Refer sr no 16



*Handwritten signature*





Project Package Contractor	KAHALGAON-II (4 x 210 MW) R&M for ESP BHEL	DOC NO. CS-4210-104A(R&M)-2
Contractor No.	CS-4210-104A(R&M)-2	REV. NO. : 0
		DATE : 18.05.2017

S.No	Item Services	QPI Insp. Cat.	QP Sub. Schedule Approval schedule	Date of submission	Date of commit Appl.	Status Code C/I/I	Proposed Sub Supplier	Place of manufacturing works	Approval Status	Sub-supplier detail submission schedule	Remarks
							Finolex Cable	Pune	A		
							Gupla Power	Bhubaneswar	A		
							STEP Industries	Alwar	A*		*. Subject to CIP clearance for points raised for Daripali.
							Scott Innovation Wires and Cables	Beddi	A		
							Cords	Bhivadi	A		
							Paramount	Khushkera	A		
							Universal Cable	Salma	A		
							TORRENT	Nadiad	A		
							Relison	Bhivadi	A		
							Polycab	Daman	A		
							Nitco	Shyamnagar	A		
							Radiant Cable	Hyderabad	A		
							KEI	Bhivadi	A		
							GemsCab	Bhivadi	A		
							INCAB	Pune	A		
							HAVELLS	Alwar	A		
							HVPL	Faridabad	A		
							Delton	Faridabad	A		ARMoured CABLE UPTO 3.6 C X 240SQM
							TORRENT	Nadiad	A		
							INCAB	Pune	A		
							R.R. Kabla	Silvata	DR		
							Elkay Telelnx	Faridabad	DR		
							KEC International	Vadodara	DR		
							Ravin Cable	Pune	A		
							Thermocables	Hyderabad	A		
							Suyog Cables	Vadodara	A		
							Sri Ram Cables	Bhivadi	A		
							Sbee Cables	Bengaluru	A		
							Trupati Plasmatrics	Jaipur	A		
							Advance Cable	Bengaluru	A		
							Finolex Cable	Pune	A		
							Gupla Power	Bhubaneswar	A		
							STEP Industries	Alwar	A*		*. Subject to CIP clearance for points raised for Daripali.
							Scott Innovation Wires and Cables	Beddi	A		
							CORDS Cable	Bhivadi	A		
							HVPL	Faridabad	A		
							GemsCab	Bhivadi	A		
							KEI	Bhivadi	A		
							Radiant	Hyderabad	A		



*[Handwritten signature]*

*[Handwritten signature]*



Project	KAHALGAON-II (4 x 210 MW)	STATUS OF ITEM REQUIRING OP & SUB-SUPPLIER APPROVAL	DOC NO. CS-4210-104A(R&M)-2
Package	R&M for ESP	ESP R&M - ELECTRICAL	REV. NO. : 0
Contractor	BHEL		DATE : 18.05.2017
Contractor No.	CS-4210-104A(R&M)-2		

S.No	Item Services	QP/ Insp. Cat.	QP Sub. Schedule Approval schedule	Date of sub-mission	Date of commt Appl.	Status Code C/III	Proposed Sub-Supplier	Place of manufacturing works	Approval Status	Sub-supplier detail submission schedule	Remarks
		I					Rallison	Bhivadi	A		
		I					Eikay Telelink	Fardabad	A		
		I					POLYCARB	Daman	A		
		I					NICCO	Shyamnagar	A		
		I					TORRENT	Nad'jad	A		
		I					Universal Cable	Saha	A		
		I					Dellon	Fardabad	A		
		I					R.R. Kable	Silvasa	A		
		I					Paramount Cable	Alwar	A		
		I					HAVELLS	Alwar	A		
		I					Gupla Power	Bhubaneshwar	A		
		I					SPM cables	Hyderabad	A		
		I					Ravin Cables	Pune	A		
		I					Suyog Cables	Vadodara	A		
		I					Incab	Pune	A		
		I					RR Kabel	Silvasa	A		
		I					Thermocables	Hyderabad	A		
		I					Triupati Plasomalics	Jajpur	A		
		I					Advance Cable	Bangaluru	A		
		I					Finolex	Pune	A		
		I					KEG International	Vadodara	DR		
		I					Sbee Cables	Bangaluru	A		
		I					STEP Industries	Alwar	A*		*. Subject to CTR clearance for politics related for Bhufipali.
		I					Eikay Telelink	Fardabad	A		
		I					Scott Innovation Wires and Cables	Baddi	A		
		I					BHEL EPD	Bangalore	A		
12	Insulators (Bushing, Support, Shaft)						BHEL Approved Sources				Insulator make shall be BHEL/W/SI/S/UC/E/ Aditya Birla SQP
13	Disconnecting Switch	III					Steelite	Mumbai	A		
14	Flexible Cable Tray Supporting System	II					Inar Profiles Ltd	Ankapally	A		GALVANISING AT VISAKHA STEEL ANAKAPALLI
		II					Indiana Gratings	Pune	A		SQP,GALVANISING AT POONA GALVANISER-PUNE
		II					Valco	Mumbai	A		SQP,GALVANISING AT SIGMA MUMBAI
		II					Amitech	Pune	A		SQP,GALVANISING AT NTPC APPROVED SOURCES
		II					Ind mark Formtech	Pune	A		Galvanising at NEHA
		II					Premier Power	Kolkata	A		SQP
		II					Industrial Perforation	Calcutta	A		SQP, NTPC approved galvanizing source
		II					Ratan	Bhagbatpur			SQP, NTPC approved galvanizing source
		III					Ratan Engg	Calcutta	A		SOURCES

4



	Project	KAHALGAON-II (4 x 210 MW)	STATUS OF ITEM REQUIRING QP & SUB-SUPPLIER APPROVAL		DOC NO. CS-4210-104A(R&M)-2
	Package	R&M for ESP	ESP R&M - ELECTRICAL		REV. NO. : 0
	Contractor	BHEL			DATE : 18.05.2017
	Contractor No.	CS-4210-104A(R&M)-2			

S.No	Item Services	QP/ Insp. Cat.	OP Sub. Approval Schedule	Date of sub-mission	Date of commit Appl.	Status Code C/J/I	Proposed Sub-Supplier	Place of manufacturing works	Approval Status	Sub-supplier detail submission schedule	Remarks
		III					Sleelita	Mumbai	A	SQP	SQP GALVANISING AT POONA GALVANISER-PUNE
		III					Indiana Gratings	Pune	A		
		III					IMJ Engg	Delhi/Bhiwadi	A	SQP	SQP GALVANISING AT NTPC APPROVED SOURCES
		III					India Electric Syndicate	Calcutta	A	SQP	SQP GALVANISING AT SIGHA, MUMBAI ANKAPALLI
		III					Vatco	Mumbai	A		
		III					Inar Profiles Ltd	Ankapatly	A		
		III					Janna Metals	Delhi/Sonept	A		
		III					Indiana	Mumbai	A	SQP	SQP GALVANISING AT KARAMTARA
		III					Techno Engg	Chandigarh	A	SQP	
		III					Anad udyog	Thane	A	SQP	
		III					Industrial Perforation	Calcutta	A	SQP	
		III					Calcutta Mfg	Calcutta	DR	SQP	
		III					Ind mark Formtech	Pune	A		
		III					Premier Power	Kolkata	A		Galvanizing at NEHA
		III					AV Engg	Kolkata	A		
		III					Ralem	Bhagbajour	A	SQP, MTPC approved galvanizing source	
		III					Amtech	Pune	A	SQP	Galvanizing at BG Shikha
		III					Rukmani	Rajpur	A		
		III					Patny	Hyderabad	A		
		III					Unitech Fabricators & Engineers	Howrah/Hoogly (Kolkata)	A		
		III					Passive Infra	Ashangarh (Rohatak)	A		
		III					Rabi Engg	Kolkata	A	SQP, MTPC approved galvanizing source	Galvanizing at TN Radhakrishna Shetty & Co
		III					T.R.G	Chennai	A		
		II					Indiana Cable trays	Mumbai	A		Galvanizing at Karamtara
15	Lighting Transformer (Epoxy Insulated)	II					Gujarat Plug In	Vadodara	A	SQP	
		II					Prayog	Pune	A	SQP	
		II					Indocil	Mumbai	A	SQP	
		II					Pragati	Thane	A	SQP	
		II					Southern Elect	Chennai	A	SQP	
		II					Padli	Thane	A	SQP	
		II					AE	Mumbai	A	SQP	
		II					KPEL	Pune	A	SQP	
		III					KEC	Solapur	A	SQP	
		III					LHP	Solapur	A	SQP	
		III					New Allenbury Works	Calcutta	A		
		III					PBL	V.V Nagar	A		
		II					Internal Combustion	Aurangabad	A		

*Handwritten signature*



Project		KAHALGADON-II ( 4 x 210 MW)		STATUS OF ITEM REQUIRING QP& SUB-SUPPLIER APPROVAL		DOC NO. CS-4210-104A(R&M)-2				
Package		R&M for ESP		ESP R&M - ELECTRICAL		REV. NO. : 0				
Contractor		BHEL				DATE : 18.05.2017				
Contractor No.		CS-4210-104A(R&M)-2								
S.No	Item Services	QPI Insp. Cat.	QP Sub. Schedule Approval schedule	Date of sub-mission	Status Code O/In	Proposed Sub Supplier	Place of manufacturing works	Approval Status	Sub-supplier detail submission schedule	Remarks
18	Panel Type Hopper Heater	III				Bongiloi HTD	Chennai USA	DR A		
		II				Hofall EHS	USA	A		
		II				HTD HEAT TRACE(I) Pvt Ltd	Hyderabad	A		
		I				Thermon	USA	A		
		II				Thermopads(Unit-II)	Hyderabad	DR		
		I				Thermon	Pune	A		
19	Tubular Type Heater	III				BHEL Approved Sources				
20	Lighting Fixtures & Luminaires	III				Wipro	Pune	A		
		III				Crompton	Mumbai	A		
		III				Phillips	Pune	A		
		III				Bejaj	Mumbai	A		
21	Welding Receptacles	III				SCHIEDER	Nasik	A		
		III				AJIMERA	Mumbai	A		
		II				Best & Crompton	Chennai	A		
		III				BCH	Faridabad	A		
22	Lighting Wires / GI Conduit	III				BIS Licencee		A		Any make with VDE or CE or UL or CSA marking or BIS approved with valid CML number.
23	Cable Gland	III				Arup Engg	Kolkata			
		III				Sunil & Co	Kolkata	A		
		III				Quality Precision	Kolkata	A		Any other make with VDE or CE or UL or CSA marking or BIS approved with valid CML number.
24	Lugs	III				Comet	Mumbai	A		
		II				Dowells	Mumbai	A		Any other make with VDE or CE or UL or CSA marking or BIS approved with valid CML number.
		II				Chitra	Nasik	A		
		III				3D	Umbergaon	A		
25	Emergency Light, Tri-bill Clamps, Ceiling Fans	III				BHEL Approved Sources				
26	M.S. ROD, G.I. Flat, G.I. Wire, Earth Wire	III				BHEL Approved Sources				
27	Local Motor Starter Panels	III				SIEMENS	Mumbai			GALVANISING AT NTPC APPROVED SOURCES
		III				L&T	Mumbai			Any other make with VDE or CE or UL or CSA marking or BIS approved with valid CML number.
28	Limit Switches	III				KAKU BHILLAI	Chennai	N		Any other make with VDE or CE or UL or CSA marking or BIS approved with valid CML number.
		III				Jai Balaji	Chennai	N		
		II				AG System	Mumbai	N		
		II				Electromag	Mumbai	N		
		III				BCH	Faridabad	N		
29	HT Termination & Joining Kits	III				3M	Pune	A		
30	Fire sealing system - Type A Material supplier	III				Raychem	Pune	A		
		III				3M India	Bangalore	A		
		III				GE Silicon	USA	A		

Handwritten signature or initials.



S.No	Item Services	QP/ Insp. Cat.	QP Sub. Schedule Approval schedule	Date of sub-mission	Date of sub-commitment Appl.	Status Code C/III	Proposed Sub Supplier	Place of manufacturing works	Approval Status	Sub-supplier detail submission schedule	Remarks
31	Fire sealing system - Type B Material supplier	III					DOW Corning	USA	A		
		III					LLOYDS	Delhi	A		
		III					Signum	Nagpur	A		
32	Executing Agency for Fire sealing system	III					Vijay System Engineers Pvt Ltd	Mumbai	A		
		I					LLOYDS	Delhi	A		
		I					Signum	Nagpur	A		
		I					Vijay System Engineers Pvt Ltd	Mumbai	A		
33	FOP of electrical Equipment - (New & Replacement)	I					3M India	Bangalore	A		
34	Interlocks for ESP	III					BHEL				
35	Containerised Sub-Station	III					BHEL Approved Sources				SUB QR ITEM

**LEGENDS :**

A - For those items proposed vendor is acceptable to NTPC, subject to meeting the NTPC Specification requirements. To be indicated with letter "A" in the list along with the condition of approval, if any. DR -- "Details required" for NTPC review. N - "NOTED" - For these items vendors are approved by Main Supplier and accepted by NTPC without specific vendor approval from NTPC. To be identified with "NOTED".

**QP INSPECTION CATEGORY :**

CAT - I: For those items, the Quality Plans are approved by NTPC and final acceptance will be on physical inspection and witness by NTPC.  
 CAT - II: For those items, the Quality Plans are approved by NTPC. However no physical inspection shall be done by NTPC. The final acceptance by NTPC shall be on the basis of review of documents.

CAT - III: For those items main supplier approves Quality Plan. The final acceptance by NTPC shall on the basis of Certificate of Conformance by main supplier.

Note- 1 : I) For Motors less than 30 KW: Acceptance of Motor less than 30 KW is based on COC of the Manufacturer and the Contractor confirming as follows: "It is hereby confirmed that the above mentioned motor /motors was/ were manufactured taking care of NTPC specific requirements regarding ambient temp., voltage & frequency variation, hot starts, pull out torque, starting KVA/KW, temp. rise, distance between centre of stud & gland plate and tested in accordance with approved drawing /data sheets".  
 II) For Motors 30 KW and less than 50 KW : Acceptance of Motor rating from 30 KW & upto 50 KW is based on NTPC review of Routine Test inspection report as per IS: 325/applicable standards duly witnessed by main contractor along with COC of the Manufacturer and the Contractor confirming as follows: "It is hereby confirmed that the above mentioned motor /motors was/ were manufactured taking care of NTPC specific requirements regarding ambient temp., voltage & frequency variation, hot starts, pull out torque, starting KVA/KW, temp. rise, distance between centre of stud & gland plate, space heater and tested in accordance with approved drawing /data sheets". III) For Motors 50 KW & above : AS PER NTPC APPROVED QUALITY PLAN (To be submitted separately for NTPC review & approval).

Note- 2 : This is indicative list. MAKES OF ANY ITEM WHICH IS NOT INCLUDED IN THE ABOVE LIST IS SUBJECT TO NTPC APPROVAL

Note- 3 : In case of Galvanised JB, galvanisation shall be carried out at NTPC approved sources .

Note- 4 : Electrical items of Ash handling System, if any will be tied up separately with accepted vendor for Ash handling Package.

FORMAT NO.: QS-01-QAI-P-1/F3-RO



*(S.N. Gupta)*  
 ENGG. DIV /DAI  
 NTPC

श्री. एन. कारुणिकी लक्ष्मणन्  
 श्री. कृष्ण प्रसाद | K. C. GANDHI PARIMALAM  
 श्री. मणोरम | Dy. General Manager | QA  
 गुणवत्ता | Quality Dept.

BHEL, BAP, Ranipet - 632 406.





**KAHALGAON STPS (R&M) STAGE-I  
(4X210MW)  
HVAC SYSTEM**

**SPECIFICATION No: PE-TS-455-571- 15000A-  
A002**

**SECTION : I**

**SUB-SECTION : E**

**REV 00**

**SECTION-I  
SUB SECTION –E**

- **ANNEXURE-II - MANDATORY SPARES LIST  
(REFER SUGGESTIVE PRICE FORMAT)**
- **ANNEXURE-III - PAINTING & COLOUR SCHEME  
(REFER SECTION C2)**
- **ANNEXURE-IV - LIST OF TOOLS & TACKLES  
(REFER SUGGESTIVE PRICE FORMAT)**
- **ANNEXURE-V - MASTER DRAWING LIST WITH  
SCHEDULE OF SUBMISSION (COVERED UNDER  
SUB-SECTION C2-B)**



**KAHALGAON STPS (R&M) STAGE-1  
(4X210MW)  
HVAC SYSTEM  
FORMAT FOR OPERATION AND  
MAINTENANCE MANUAL**

**SPECIFICATION No: PE-TS-455-571- 15000A-  
A002**

**SECTION : I**

**SUB-SECTION : E**

**REV 00**

**SHEET 1 OF 4**

**SECTION-I  
SUB-SECTION-E  
ANNEXURE-VI  
FORMAT FOR OPERATION AND MAINTENANCE  
MANUAL**



**KAHALGAON STPS (R&M) STAGE-1  
(4X210MW)  
HVAC SYSTEM  
FORMAT FOR OPERATION AND  
MAINTENANCE MANUAL**

**SPECIFICATION No: PE-TS-455-571- 15000A-A002**

**SECTION : I**

**SUB-SECTION : E**

**REV 00**

**SHEET 2 OF 4**

**Project name :**  
**Project number :**  
**Package Name :**  
**PO reference :**  
**Document number :**  
**Revision number :**

Sl.no. & Sections	Description	Tick ( √ )if included in Manual			Remarks
		Yes	No	Not Applicable	
<b>1.</b>	<b>COVER PAGE</b>				
<b>1.1</b>	Project Name				
<b>1.2</b>	Customer/consultant Name				
<b>1.3</b>	Name of Package				
<b>1.4</b>	Supplier details with phone, FAX ,email address , Emergency Contact number				
<b>1.5</b>	Name and sign of prepared by , checked by & approved by				
<b>1.6</b>	Revision history with approval Details				
<b>2.0</b>	<b>INDEX</b>				
<b>2.1</b>	showing the sections & related page nos All the pages should be numbered section wise				
<b>3.0</b>	<b>DESCRIPTION OF PLANT/SYSTEM</b>				
<b>3.1</b>	Description /write up of operating principle of system equipment/ associated sub-systems & accessories/controls system , operating conditions, performance parameters under normal , start up and special cases				
<b>3.2</b>	Equipment list and basic parameter with Tag numbers				
<b>3.3</b>	Data sheets approved by Customer/for information and catalogues provided by original manufacturer				
<b>3.4</b>	Associated other packages and Interface /terminal points				
<b>3.5</b>	P&ID & Process Diagrams				
<b>3.6</b>	GA Layout drawings, As-built drawings , Actual photograph of items/system (Drawings of A2 & bigger sizes are to be attached in the last)				
<b>3.7</b>	Single line/wiring diagrams				
<b>3.8</b>	Control philosophy /control write-ups				



**KAHALGAON STPS (R&M) STAGE-1  
(4X210MW)  
HVAC SYSTEM  
FORMAT FOR OPERATION AND  
MAINTENANCE MANUAL**

**SPECIFICATION No: PE-TS-455-571- 15000A-A002**

**SECTION : I**

**SUB-SECTION : E**

**REV 00**

**SHEET 3 OF 4**

Sl.no. & Sections	Description	Tick ( √ )if included in Manual			Remarks
		Yes	No	Not Applicable	
<b>4.0</b>	<b>COMMISSIONING ACTIVITIES (IF NOT COVERED IN SEPARATE DOCUMENT I.E. ERECTION MANUAL, COMMISSIONING MANUAL)</b>				
<b>4.1</b>	Pre-Commissioning Checks				
<b>4.2</b>	handling of items at site				
<b>4.3</b>	Storage at site				
<b>4.4</b>	Unpacking & Installation procedure				
<b>5.0</b>	<b>OPERATION GUIDELINES FOR PLANT PERSONAL/USER/OPERATOR</b>				
<b>5.1</b>	Interlock & Protection logic along with the limiting values of protection settings for the equipment along with brief philosophy behind the logic, drawings etc. to be provided.				
<b>5.2</b>	Start up, normal operation and shut down procedure for equipments along with the associated systems in step by step mode. Valve sequence chart, step list, interlocks etc. with Equipment isolating procedures to be mentioned.				
<b>5.3</b>	Do's & Don't of the equipments.				
<b>5.4</b>	Safety precautions to be taken during normal operation. Safety symbols, Emergency instructions on total power failure condition/lubrication failure/any other condition				
<b>5.5</b>	Parameters to be monitored with normal values and limiting values				
<b>5.6</b>	Trouble shooting with causes and remedial measures				
<b>5.7</b>	Routine operational checks, recommended logs & records				
<b>5.8</b>	Changeover schedule if more than one auxiliary for the same purpose is given				
<b>5.9</b>	Painting requirement and schedule				
<b>5.10</b>	Inspection, repair , Testing and calibration procedures				
<b>6.0</b>	<b>MAINTENANCE GUIDELINES FOR PLANT PERSONAL</b>				



**KAHALGAON STPS (R&M) STAGE-1  
(4X210MW)  
HVAC SYSTEM  
FORMAT FOR OPERATION AND  
MAINTENANCE MANUAL**

**SPECIFICATION No: PE-TS-455-571- 15000A-A002**

**SECTION : I**

**SUB-SECTION : E**

**REV 00**

**SHEET 4 OF 4**

Sl.no. & Sections	Description	Tick ( √ )if included in Manual			Remarks
		Yes	No	Not Applicable	
6.1	List of Special Tools and Tackles required for Overhaul/Trouble shooting including special testing equipment required for calibration etc.				
6.2	Stepwise dismantling and re-assembly procedure clearly specifying the tools to be used, checks to be made, records to be maintained, clearances etc. to be mentioned. Tolerances for fitment of various components to be given.				
6.3	Preventive Maintenance & Overhauling schedules linked with running hours/calendar period along with checks to be given				
6.4	Long term maintenance schedules especially for structural, foundations etc.				
6.5	Consumable list along with the estimated quantity required during commissioning, normal running and during maintenance like Preventive Maintenances and Overhaul. Storage/handling requirement of consumables/self-life.				
6.6	List of lubricants with their Indian equivalent, Lubrication Schedule, Quantity required for each equipment for complete replacement is to be given				
6.7	List of vendors & Sub-vendors with their latest addresses, service centres ,Telephone Nos., Fax Nos., Mobile Nos., e-mail IDs etc.				
6.8	List of mandatory and recommended spare parts list				
6.9	Tentative Lead time required for ordering of spares from the equipment supplier				
6.10	Guarantee and warranty clauses				
7.0	<b>Statutory and other specific requirements considerations.</b>				
8.0	<b>List of reference documents</b>				
9.0	<b>Binding as per requirement</b>				



**KAHALGAON STPS (R&M) STAGE-1  
(4X210MW)  
HVAC SYSTEM  
SITE STORAGE AND PRESERVATION**

**SPECIFICATION No: PE-TS-455-571- 15000A-  
A002**

**SECTION : I**

**SUB-SECTION : E**

**REV 00**

**SECTION-I  
SUB-SECTION-E  
ANNEXURE-VII  
SITE STORAGE AND PRESERVATION**

# SITE STORAGE AND PRESERVATION GUIDELINES FOR MECHANICAL BOPs

(Doc No: PE-DC-SSG-A001 REV.00)



PROJECT ENGINEERING MANAGEMENT, POWER SECTOR  
BHARAT HEAVY ELECTRICALS LIMITED-NOIDA

## **CONTENT**

- 1 SCOPE OF THE DOCUMENT
- 2 PURPOSE OF STORAGE & PRESERVATION
- 3 MEASURES TO BE TAKEN FOR STORAGE AND PRESERVATION
  - a) GENERAL STORAGE REQUIREMENTS
  - b) GENERAL PRESERVATION REQUIREMENTS
  - c) GENERAL INSPECTION REQUIREMENTS
- 4 TYPE OF STORAGE FOR VARIOUS EQUIPMENT
5. CONCLUSION
6. STACKING ARRANGEMENT FOR PLATES AND STRUCTURAL STEEL

## **1. SCOPE OF THE DOCUMENT**

This guideline is prepared in intent to provide proper site storage and preservation of the Mechanical, Electrical and C & I items / equipment supplied under various bought out packages/items. This storage procedure shall be followed at different power plant sites by concerned agency for storage and preservation from the date of equipment received at site until the same are erected and handed over to the customer.

## **2. PURPOSE OF STORAGE & PRESERVATION**

Many of the items may be required to be kept in stores for long period. It shall therefore be essential that proper methods of storage and preservation be applied so that items do not deteriorate, lose some of their properties and become unusable due to atmospheric conditions and biological elements.

## **3. MEASURES TO BE TAKEN FOR STORAGE, HANDLING & PRESERVATION**

### **a) GENERAL STORAGE REQUIREMENTS**

1. To the extent feasible, materials should be stored near the point of erection. The storage areas should have adequate unloading and handling facilities with adequate passage space for movement of material handling equipment such as cranes, fork lift trucks, etc. The storage of materials shall be properly planned to minimise time loss during retrieval of items required for erection.
2. The outdoor storage areas as well as semi-closed stores shall be provided with adequate drainage facilities to prevent water logging. Adequacy of these facilities shall be checked prior to monsoon.
3. The storage sheds shall be built in conformity with fire safety requirements. The stores shall be provided with adequate lights and fire extinguishers. 'No smoking' signs shall be placed at strategic locations. Safety precautions shall be strictly enforced.
4. Adequate lighting facility shall be provided in storage areas and storage sheds and security personnel positioned to ensure enforcement of security measures to prevent theft and loss of materials.
5. Adequate number of competent stores personnel and security staff shall be deployed to efficiently store and maintain the equipment / material.
7. The equipment shall be stored in an orderly manner, preserving their identification slips, tags and instruction booklets, etc., required during erection. The storage of materials shall be equipment-wise. Loose parts shall be stored in sheds on racks,

preserving the identification marks and tags in good condition. The group codes shall be displayed on the racks

6. At no time shall any materials be stored directly on ground. All materials shall be stored minimum 200 mm above the ground preferably on wooden sleepers

**b) GENERAL PRESERVATION REQUIREMENTS**

1. All special measures to prevent corrosion shall be taken like keeping material in dry condition, avoiding the equipment coming in contact with corrosive fluid like water, acid etc.
2. Materials which carry protective coating shall not be wrapped in paper, cloth, etc., as these are liable to absorb and retain moisture. The material shall be inspected and in case of signs of wear or damages to protective coating, that portion shall be cleaned with approved solution and coated with an approved protective paint. Complete record of all such observations and protective measures taken shall be maintained.
3. Generally equipment supplied at site are properly greased or rust protective oil is applied on machined/ fabricated components. However periodic inspection shall be carried out to ensure that protection offered is intact.
4. While handling the equipment, no dragging on the ground is permitted. Avoid using wire rope for lifting coated components. Use polyester slings (if possible) otherwise protective material (e.g. clothes, wood block etc.) should be used while handling the components with rope / slings
5. For Equipment supplied with finished paint, touch paint shall be done in case any surface paint gets peeled off during handling. Otherwise such surfaces shall necessarily be wrapped with polythene to avoid any corrosion. Further for equipment wherein finish coat is to be applied at site, site to ensure that equipment is received with primer coat applied.
6. It shall be ensured by periodic inspection that plastic inserts are intact in tapped holes, wherever applicable.
7. Pipes shall be blown with air periodically and it shall be ensured that there is no obstruction.
8. Silica gel or approved equivalent moisture absorbing material in small cotton bags shall be placed and tied at various points on the equipment, wherever necessary.
9. Heavy rotating parts in assembled conditions shall be periodically rotated to prevent corrosion/jamming due to prolonged storage.

10. All the electrical equipment such as motors, generators, etc. shall be tested for insulation resistance at least once in three months and a record of such measured insulation values shall be maintained.
11. Following preservatives/preservation methods can be used depending upon type of equipment
  - a. Rust preventive fluid (RPF)
  - b. Rust protective paints
  - c. Tarpaulin covers, in case of outdoor storage
  - d. De-oxy aluminate for weld-ments

**c) GENERAL INSPECTION REQUIREMENTS**

1. Period inspection of materials with specific reference to –
  - Ingress of moisture and corrosion damages.
  - Damage to protective coating.
  - Open ends in pipes, vessels and equipment -
    - In case any open ends are noticed, same shall be capped.
2. Any damages to equipment / materials.
  - In case of any damages, these shall be promptly notified and in all cases, the repairs / rectification shall be carried out.
  - Any items found damaged or not suitable as per project requirements shall be removed from site. If required to store temporarily, they shall be clearly marked and stored separately to prevent any inadvertent use.

#### 4. TYPE OF STORAGE FOR VARIOUS EQUIPMENT

The types of storage are broadly classified under the following heads:

i **Closed storage with dry and dust free atmosphere. (C )**

The closed shed can be constructed by using cold-rolled / tubular components for structure and corrugated asbestos sheets / galvanised iron sheets for roofing. Brick walls / asbestos sheets can be used to cover all the sides. The floor of the shed can be finished with plain cement concrete suitably glazed. The shed shall be provided with proper ventilation and illumination.



ii **Semi-closed storage. (S)**

The semi closed shed can be constructed by using cold-rolled / tubular components for structure and corrugated / asbestos sheets for roofing. The floor shall be brick paved. If required a small portion of sides can be covered to protect components from rainwater splashing onto the components.





iii Open storage (O )

The open yard shall be levelled, well consolidated to achieve raised ground with the provision of feeder roads for crane approach along with access roads running all sides. One part of the open yard shall be stone pitched, levelled and consolidated with raised ground suitable for storing / stacking heavier and critical components with due space to handle them by cranes etc . Adequate number of sleepers, concrete block etc. to be provided to make raised platforms to stack critical materials.

A separate yard to be identified as “scrap yard” slightly away from main open yard to store wooden/steel scraps, which are to be disposed off. This is required to avoid mix up with regular components as well as to avoid fire hazard.

Some of the components, which are having both machined & un-machined surfaces and are bulky, shall be stored in open storage area on a raised ground and suitably covered with water proof / fire retardant tarpaulin.



The equipment listed below shall be stored and inspected as per requirement mentioned in the table below.

Sl. No.	Description of the equipment	Type of Storage	Check for	Remarks
<b>Raw material /mechanical items like pipes, plates, structure sections etc.)</b>				
1.	Steel pipes ( lined/unlined)	S	Damage , paint, corrosion, rubber lining peeling	Provide end cap
2.	MS Plates	S	Damage, paint, corrosion	
3.	SS Plates	S	Damage	
4.	Non-metallic pipes	S	Damage, cracks	Provide end cap
5.	Stainless steel pipes	S	Damage ,	Provide end cap
6.	MS sections, beams	S	Damage, paint, corrosion	
7.	Cable trays	S	Damage, condition of preservations	
8.	Insulation sheets	S	Damage	
9.	Insulation	C	Damage, packing	
10.	Hangers Rods	S	Damage, paint, packing	
11.	Tubes	S	Damage, paint , packing	Provide end cap
12.	Hume pipes	O	Damage	
13.	Castings	O	Damage, paint, corrosion	
<b>Fabricated mechanical items (pressure vessels, tanks etc.)</b>				
14.	Pressure vessels (unlined)	O	Damage, paint, corrosion,	Covered nozzles
15.	Atmospheric storage tanks (unlined)	O	Damage, paint, corrosion	Covered nozzles

Sl. No.	Description of the equipment	Type of Storage	Check for	Remarks
16.	Pressure vessels (lined)	S	Damage, paint, corrosion, rubber lining	
17.	Atmospheric storage tanks(lined)	S	Damage, paint, corrosion, rubber lining	
18.	Support structures	O	Damage , paint, corrosion	
19.	Flanges	C	Damage , paint, corrosion	
20.	Fabricated pipes	S	Damage , paint, corrosion	Provide end cap
21.	Vessels internals	C	Damage , paint, corrosion ,packing	
22.	Grills	S	Damage , paint, corrosion	
23.	Angles	S	Damage , paint, corrosion	
24.	Bridge mechanism/clarifier mechanism	O	Damage , paint, corrosion	
25.	Cranes, rails	S	Damage , paint, corrosion	
26.	Stair cases	O	Damage , paint, corrosion	
27.	Ladders/handrails	O	Damage , paint, corrosion	
28.	Fabricated ducts	S	Damage , paint, corrosion	
29.	Isolation Gates	O	Damage , paint, corrosion	
30.	Fabricated boxes/panels	S	Damage , paint, corrosion	
<b>Mechanical components like valves, fittings, cables glands, spares etc.)</b>				
31.	Valves	S	Damage , packing	

Sl. No.	Description of the equipment	Type of Storage	Check for	Remarks
32.	Fittings	S	Damage , packing	Provide end cap
33.	Cable glands	C	Damage , packing	
34.	Tools & tackles	C	Damage , packing	
35.	Nut , bolts, washers,	C	Damage , packing	
36.	Gasket & Packings	C	Damage , packing	
37.	Copper tubes	C	Damage , packing, corrosion	Provide end cap
38.	SS tubing	C	Damage , packing	Provide end cap
<b>Rotating assemblies (pumps, blowers, stirrers, fans, compressors etc.)</b>				
39.	Pumps	S	Damage , packing, corrosion	Shaft rotation
40.	Blowers/Compressors	S	Damage , packing, corrosion	Shaft rotation
41.	Agitators/stirrers/radial launders	C	Damage , packing, corrosion	Shaft rotation
42.	Rollers for chlorine tonner mounting	C	Damage , packing, corrosion	
43.	Centrifuge	S	Damage , packing,	
44.	Gear box	C	Damage , packing, corrosion	
45.	Bearings	C	Damage , packing, corrosion	
46.	Fans	S	Damage , packing, corrosion	
47.	Dosing skids	S	Damage , packing, corrosion	
48.	Pump assemblies	S	Damage , packing, corrosion	
49.	Air washers( INTERNALS)	S	Damage , packing	
50.	Air conditioners ( split)	C	Damage , packing	

Sl. No.	Description of the equipment	Type of Storage	Check for	Remarks
51.	Elevators( CONTAINERIZED)	O	Damage , packing, corrosion	
52.	Chillers/VA machines	S	Damage , packing	
53.	Air handling Unit/Package unit	S	Damage , packing	
54.	Chlorinators & Evaporators	C	Damage , packing	
55.	Ejectors	C	Damage , packing	
56.	Electrolyser	C	Damage , packing	
<b>Miscellaneous items like chain pulley blocks, hoists etc.</b>				
57.	Chain pulley blocks	S	Damage, Packing	
58.	Electric hoists	S	Damage, Packing	
59.	Fire extinguishers	C	Damage, expiry date	
60.	Fork Lift Truck	S	Damage, Packing	
61.	Hydraulic Mobile Crane	O	Damage, Packing	
62.	Mobile Pick Up & Carry Crane	O	Damage, Packing	
63.	Motor boats	O	Damage, Packing	
64.	Safety showers	S	Damage, Packing	
65.	Diffusers/dampers	S	Damage, Packing	
<b>Chemicals and consumables ( acid, alkali, paints, oils, reagents and special chemicals)</b>				
66.	Hydro Chloric Acid (HCl)	Store in canes/ storage tank in dyke area	Date of production/ leakage/fumes	hazardous chemical
67.	Sulphuric acid (H <sub>2</sub> SO <sub>4</sub> )	Store in canes/ storage tank in dyke area	Date of production/ leakage/fumes	hazardous chemical

Sl. No.	Description of the equipment	Type of Storage	Check for	Remarks
68.	Sodium hydroxide (NaOH)	Store in canes/ storage tank in dyke area	Date of production/ leakage/ fumes/ breather	hazardous chemical ,breather to be checked for air ingress
69.	Sodium hypo chlorite	To be stored under shed	Date of production/ leakage/ fumes	hazardous chemical ,self-life normally 15-30 days after which strength of chemical decays
70.	Ammonia	S	Date of production/ leakage/ fumes	Store in closed storage tanks, hazardous chemical
71.	CW treatment chemicals	S	Date of production , Self-life	Store in closed canes
72.	RO/UF cleaning chemicals	S	Date of production , Self-life	Store in closed canes
73.	Lime	C	Damage to packing , seepage	Prevent moisture, rain
74.	Alum bricks	C	Damage to packing	Prevent moisture, rain
75.	Poly electrolyte	S		Store in closed storage tanks
76.	Laboratory chemicals( powder)	C	Damage, Packing self- life	
77.	Laboratory chemicals( liquid)	C	Damage, Packing self- life	
78.	Lubrication oils	C	Leakage	
79.	Paints	S	Leakage ,air tightness	
80.	Sand	O	Damage of packing	No hooks
81.	Salt (NaCl)	C	Damage of packing, water ingress	Prevent moisture, rain
82.	Anthracite	S	Damage of packing	
83.	Activated carbon	S	Damage of packing	

Sl. No.	Description of the equipment	Type of Storage	Check for	Remarks
84.	Thermal insulation	S	Damage of packing	
85.	Cement	C	Damage of packing	Prevent moisture, rain
86.	Gravels	O	Damage of packing	
87.	ION exchange resins	C	Damage , packing	Refer manufacturer guidelines
88.	RO membranes	C	Damage , packing	Refer manufacturer guidelines
89.	UF membranes	C	Damage , packing	Refer manufacturer guidelines
90.	Cleaning chemicals	C	Damage , packing	Refer manufacturer guidelines
91.	Chemicals for analysers/calibration	C	Damage , packing	Refer manufacturer guidelines
<b>Electrical and C &amp; I items (motors, cables etc.)</b>				
92.	Motors	C	Damage , packing	
93.	Cable drums	O	Damage	
94.	Control Panel /control desk, UPS ,JB	S	Damage, Packing	
95.	Instruments( gauges/analysers)	C	Damage	
<b>Special items</b>		As per Manufacturer's item, like Hydrogen cylinders, Ozonator, Analyser, Chlorine dioxide generators etc.		

## **5. CONCLUSION**

Concerned storage agency at site should make sure that loss in equipment performance and wear & tear are minimised through proper storage and preservation. The above are broad guidelines and cover major equipment / materials. However specific storage practices shall be followed as per manufacturer recommendation. All the necessary measures even in addition to the ones mentioned above, if found necessary, should be taken to achieve the objective.

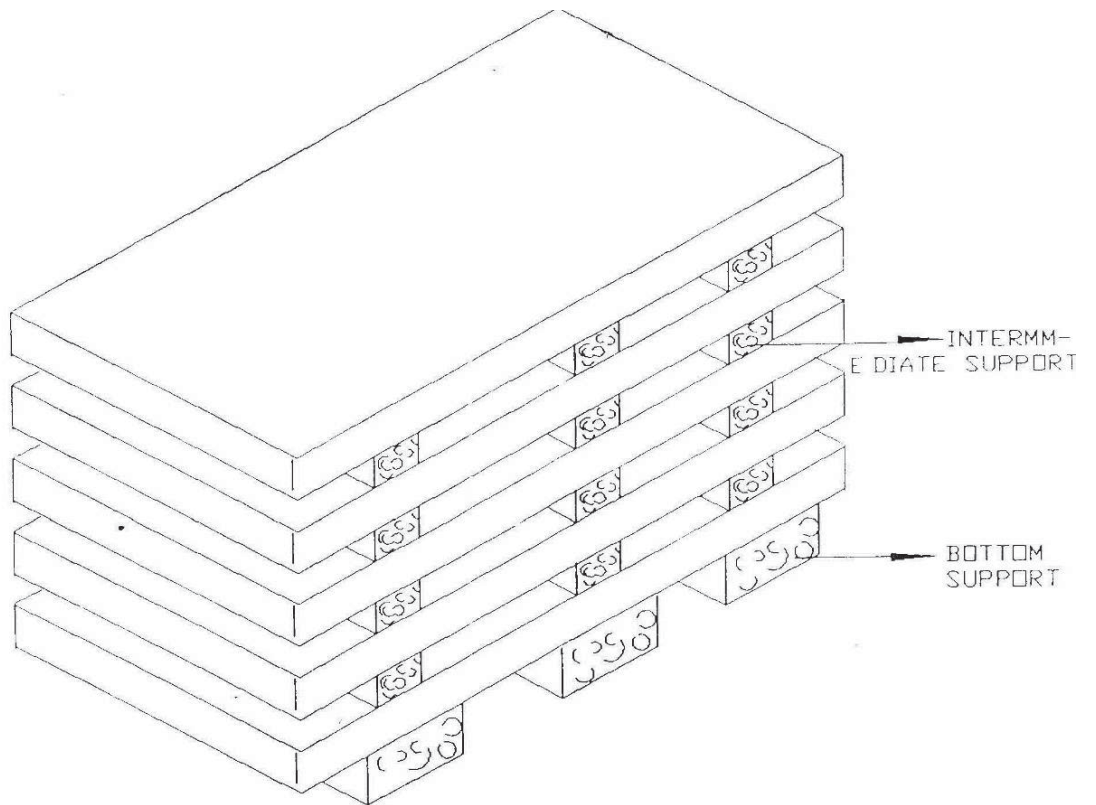

Figure - 1 - PLATE STACKING ARRANGEMENT

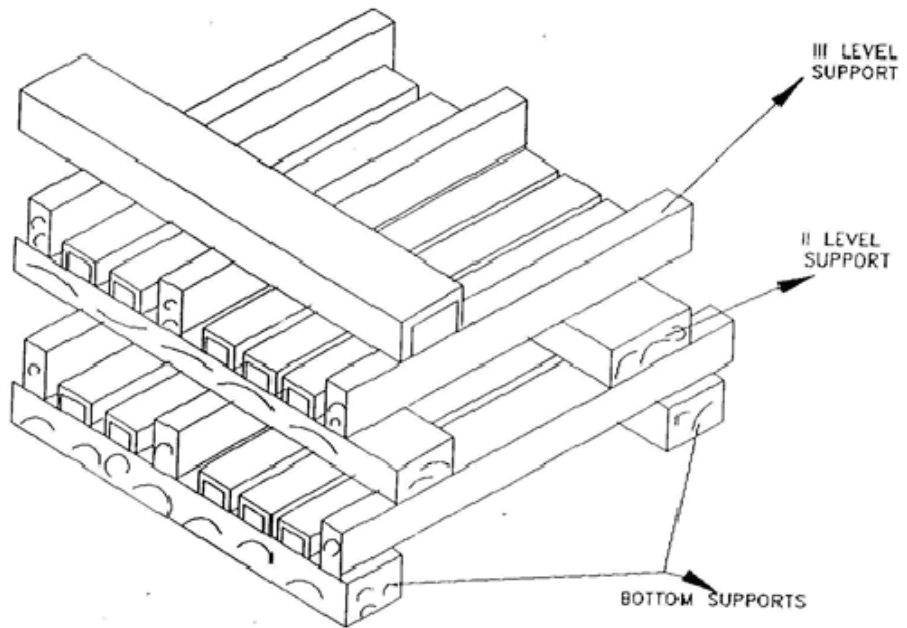

Figure - 2 - STRUCTURAL STEEL STACKING ARRANGEMENT



**KAHALGAON STPS (R&M) STAGE-1  
(4X210MW)  
INSPECTION AND TESTING**

**SPECIFICATION No: PE-TS-455-571- 15000A-  
A002**

**SECTION : II**

**SUB-SECTION : 1**

**REV 00**

**SHEET 1 OF 4**

**SECTION-II**

**SUB-SECTION-1**

**INSPECTION AND TESTING**

	<b>KAHALGAON STPS (R&amp;M) STAGE-1 (4X210MW) INSPECTION AND TESTING</b>	<b>SPECIFICATION No: PE-TS-455-571- 15000A-A002</b>	
		<b>SECTION : II</b>	
		<b>SUB-SECTION : 1</b>	
		<b>REV 00</b>	
		<b>SHEET 2 OF 4</b>	

- 1.01.00 Inspection and Tests during Manufacture.
- 1.01.01 The method and techniques to be used by the Bidder for the control of quality during manufacture of all plant and equipment shall be agreed with the Owner.
- 1.01.02 The Owner's general requirements with respect to quality control and the required shop tests are set out elsewhere in this specification.
- 1.01.03 Before any item of plant or equipment leaves its place of manufacture the Owner shall be given the option of witnessing inspections and tests for compliance with the specification and related standards.
- 1.01.04 Advance notice shall be given to the Owner as agreed in the Contract, prior to the stage of manufacture being reached, and the piece of plant must be held at this stage until the Owner has inspected the piece, or has advised in writing that inspection is waived. If having consulted the Owner and given reasonable notice in writing of the date on which the piece of plant will be available for inspection, the Owner does not attend the Bidder may proceed with manufacture having forwarded to the Owner duly certified copies of his own inspection and test results.
- The owner's representative shall have at all reasonable times access to bidder's or his sub-vendor's premises and shall have power to inspect/ examine materials and workmanship or equipment under manufacture.
- The Bidder shall forthwith forward to the engineer duly certified copies of the Test Certificates in six copies (one to the Purchaser and five to the Consulting Engineer) for approval. Further nine (9) copies of Shop Test Certificates shall be bound with Instruction Manuals referred to elsewhere.
- For electrical equipment, routine tests as per relevant IS spec are to be carried out on all equipment. Type tests are also to be carried out on selected equipment as detailed in the specs of concerned electrical equipment.
- 1.01.05 Under no circumstances any repair or welding of castings be carried out without the consent of the Engineer. Proof of the effectiveness of each repair by radiographic and/or other non-destructive testing technique, shall be provided to the Engineer.
- 1.01.06 All the individual and assembled rotating parts shall be statically and dynamically balanced in the works.  
Where accurate alignment is necessary for component parts of machinery normally assembled on site, the Bidder shall allow for trial assembly prior to dispatch from place of manufacture.
- 1.01.07 All materials used for the manufacture of equipment covered under this specification shall be of tested quality. Relevant test certificates shall be made available to the Purchaser. The certificates shall include tests for mechanical properties and chemical analysis of representative material. Equipment or parts coming under any statutory

	<b>KAHALGAON STPS (R&amp;M) STAGE-1 (4X210MW) INSPECTION AND TESTING</b>	<b>SPECIFICATION No: PE-TS-455-571- 15000A-A002</b>	
		<b>SECTION : II</b>	
		<b>SUB-SECTION : 1</b>	
		<b>REV 00</b>	
		<b>SHEET 3 OF 4</b>	
	<p>Regulations shall be certified by a Competent Authority under the regulations in the specified format.</p>		
1.01.08	<p>All pressure parts connected to pumping main shall be subjected to hydraulic testing at a pressure of 150% of shut-off head for a period not less than one hour. Other parts shall be tested for one and half times the maximum operating pressure, for a period not less than one hour.</p>		
1.01.09	<p>All necessary non-destructive examinations shall be performed to meet the applicable code requirements.</p>		
1.01.10	<p>All welding procedures adopted for performing welding work shall be qualified in accordance with the requirements of Section-IX of ASME code or IBR as applicable. All welded joints for pressure parts shall be tested by liquid penetrant examination according to the method outlined in ASME Boiler and Pressure Vessel code. Radiography, magnetic particle examination magniflux and ultrasonic testing shall be employed wherever necessary/ recommended by the applicable code. At least 10% of all major but welding joints shall be radiographed unless otherwise stipulated.</p> <p>Statutory payments in respect of IBR approvals including inspection shall be made by the bidder. Bidder's scope shall include to preparation of all necessary documents, co-ordination and follow-up for above approval. Owner shall only forward assistance/endorsement of documents /design /drawings /reports/records to be submitted for approval as stipulated/ required by Statutory Authorities till registration of the unit and clearance for commercial operation.</p>		
1.02.00	<p>Performance Tests at Site</p>		
1.02.01	<p>The full requirements for testing the system shall be agreed between the Owner and the Bidder prior to Award of Contract. The completely erected System shall be tested by the Bidder on site under normal operating conditions. The Bidder shall also ensure the correct performance of the System under abnormal conditions, i.e. the correct working of the various emergency and safety devices, interlocks, etc.</p>		
1.02.02	<p>The Bidder shall provide complete details of his normal procedures for testing, for the quality of erection and for the performance of the erected plant. These tests shall include site pressure test on all erected pipe work to demonstrate the quality of the piping and the adequacy of joints made at site.</p>		
1.02.03	<p>The Bidder shall furnish the quality procedures to be adopted for assuring quality from the receipt of material at site, during storage, erection, pre-commissioning to tests on completion and commissioning of the complete system/equipment.</p>		
1.03.00	<p>For details of specific tests required on individual equipment refer to respective section of this specification.</p> <p>All Statutory testing / clearance is in Bidder's scope including payment of all fees, etc. as required</p>		





**KAHALGAON STPS (R&M) STAGE-1  
(4X210MW)  
HVAC SYSTEM  
LIST OF DOCUMENTS TO BE SUBMITTED WITH  
BID**

**SPECIFICATION No: PE-TS-455-571- 15000A-A002**

**SECTION : II**

**SUB-SECTION : 2**

**REV: 00**

**SHEET 1 OF 1**

**BIDDER SHOULD SUBMIT THE SIGNED AND STAMPED COPY OF THE FOLLOWING DOCUMENTS:**

1. Compliance cum confirmation certificate
2. Un priced format for Main package, Mandatory Spares, Tools and Tackles, Commissioning Spares (mentioning quoted/not quoted against each item)
3. Deviation schedule /No deviation certificate in attached format 'Deviation sheet (Cost of withdrawal)'.



**KAHALGAON STPS (R&M) STAGE-1  
(4X210MW)  
HVAC SYSTEM  
COMPLIANCE CUM CONFIRMATION  
CERTIFICATE**

**SPECIFICATION No: PE-TS-455-571-  
15000A-A002**

**SECTION : II**

**SUB-SECTION : 3**

**REV. NO. 00**

**SHEET: 1 OF 2**

**COMPLIANCE CUM CONFIRMATION CERTIFICATE**

The bidder shall confirm compliance with following by signing / stamping this compliance certificate (every sheet) and furnish same with the offer.

- a) The scope of supply, technical details, construction features, design parameters etc. shall be as per technical specification & there are no exclusions, other than those mentioned under "exclusion and those resolved as per 'Schedule of Deviations', with regard to same.
- b) There are no other deviations w.r.t. specifications other than those furnished in the 'Schedule of Deviations'. Any other deviation, stated or implied, taken elsewhere in the offer stands withdrawn unless specifically brought out in the 'Schedule of Deviations'
- c) Bidder shall submit QP in the event of order based on the guidelines given in the specification & QP enclosed therein. QP will be subject to BHEL / CUSTOMER approval & customer hold points for inspection / testing shall be marked in the QP at the contract stage. Inspection / testing shall be witnessed as per same apart from review of various test certificates/ Inspection records etc. This is within the contracted price without any extra implications to BHEL after award of the contract.
- d) All drawings/ data-sheets / calculations etc. submitted along with the offer shall not be taken cognizance off.
- e) The offered materials shall be either equivalent or superior to those specified in the specification & shall meet the specified / intended duty requirements. In case the material specified in the specifications is not compatible for intended duty requirements then same shall be resolved by the bidder with BHEL during the pre-bid discussions, otherwise BHEL / Customer's decision shall be binding on the bidder whenever the deficiency is pointed out.

For components where materials are not specified, same shall be suitable for intended duty, all materials shall be subject to approval in the event of order.

- f) The commissioning spares shall be supplied on 'As Required Basis' & prices for same included in the base price itself.
- g) All sub vendors shall be subject to BHEL / CUSTOMER approval in the event of order.
- h) Guarantee for plant/equipment shall be as per relevant clause of GCC / SCC / Other Commercial Terms & Conditions
- i) In the event of order, all the material required for completing the job at site shall be supplied by the bidder within the ordered price even if the same are additional to approved billing break up, approved drawing or approved Bill of quantities within the scope of work as tender specification. This clause will apply in case during site



**KAHALGAON STPS (R&M) STAGE-1  
(4X210MW)  
HVAC SYSTEM  
COMPLIANCE CUM CONFIRMATION  
CERTIFICATE**

**SPECIFICATION No: PE-TS-455-571-  
15000A-A002**

**SECTION : II**

**SUB-SECTION : 3**

**REV. NO. 00**

**SHEET: 2 OF 2**

commissioning, additional requirements emerges due to customer and / or consultant's comments. No extra claims shall be put on this account

- j) Schedule of drawings submissions, comment incorporations & approval shall be as stipulated in the specifications. The successful bidder shall depute his design personnel to BHEL's / Customer's / Consultant's office for across the table resolution of issues and to get documents approved in the stipulated time.
- k) As built drawings shall be submitted as and when required during the project execution.
- l) The bidder has not tempered with this compliance cum confirmation certificate and if at any stage any tempering in the signed copy of this document is noticed then same shall be treated as breach of contract and suitable actions shall be taken against the bidder.
- m) Successful bidder shall furnish detailed erection manual for each of the equipment supplied under this contract at least 3 months before the scheduled erection of the concerned equipment / component or along with supply of concerned equipment / component whichever is earlier.
- n) Document approval by customer under Approval category or information category shall not absolve the vendor of their contractual obligations of completing the work as per specification requirement. Any deviation from specified requirement shall be reported by the vendor in writing and require written approval. Unless any change in specified requirement has been brought out by the vendor during detail engineering in writing while submitting the document to customer for approval, approved document (with implicit deviation) will not be cited as a reason for not following the specification requirement.
- o) In case vendor submits revised drawing after approval of the corresponding drawing, any delay in approval of revised drawing shall be to vendor's account and shall not be used as a reason for extension in contract completion.



**KAHALGAON STPS (R&M) STAGE-1  
(4X210MW)**

**HVAC SYSTEM  
PRE-BID CLARIFICATION SCHEDULE**

**SPECIFICATION No: PE-TS-455-571-  
15000A-A002**

**SECTION : II**

**SUB-SECTION : 4**

**REV. NO. 00**

**SHEET: 1 OF 1**

**PRE-BID CLARIFICATION SCHEDULE**

<b>S. NO.</b>	<b>SECTION/CLAUSE/PAGE NO.</b>	<b>STATEMENT OF THE REFERRED CLAUSE</b>	<b>CLARIFICATION REQUIRED</b>

The bidder hereby clarifies that above mentioned are the only clarifications required on the technical specification for the subject package.

Signature: \_\_\_\_\_

Name: \_\_\_\_\_

Designation: \_\_\_\_\_

Company: \_\_\_\_\_

Date: \_\_\_\_\_

Company Seal



**ANNEXURE-II: DEVIATION SHEET (COST OF WITHDRAWAL)**

**PROJECT:-** KAHALGAON STPS (R&M) STAGE-1 (4X210MW)

**PACKAGE:-** HVAC System

**TENDER ENQUIRY REFERENCE:-**

**NAME OF VENDOR:-**

SL NO	VOLUME/ SECTION	PAGE NO.	CLAUSE NO.	TECHNICAL SPECIFICATION/ TENDER DOCUMENT	COMPLETE DESCRIPTION OF DEVIATION	COST OF WITHDRAWAL OF DEVIATION	REFERENCE OF PRICE SCHEDULE ON WHICH COST OF WITHDRAWAL OF DEVIATION IS APPLICABLE	NATURE OF COST OF WITHDRAWAL OF DEVIATION (POSITIVE/NEGATIVE)	REASON FOR QUOTING DEVIATION
<b>TECHNICAL DEVIATIONS</b>									
<b>COMMERCIAL DEVIATIONS</b>									
<b>PARTICULARS OF BIDDERS' AUTHORISED REPRESENTATIVE</b>									

**NAME**

**DESIGNATIONS**

**SIGN & DATE**

**NOTES:**

- Cost of withdrawal of deviation will be applicable on the basic price (i.e. excluding taxes, duties & freight) only.
- All the bidders have to list out all their Technical & Commercial Deviations (if any) in detail in the above format.
- Any deviation not mentioned above and shown separately or found hidden in offer, will not be taken cognizance of.
- Bidder shall submit duly filled unpriced copy of above format indicating "quoted" in "cost of withdrawal of deviation" column of the schedule above along with their Techno-commercial offer, wherever applicable. In the absence of same, such deviation(s) shall not be considered and offer shall be considered in total compliance to NIT.
- Bidder shall furnish price copy of above format along with price bid.
- The final decision of acceptance/rejection of the deviations quoted by the bidder shall be at discretion of the Purchaser.
- Bidders to note that any deviation (technical/commercial) not listed in above and asked after Part-1 opening shall not be considered.
- For deviations wrt I. Credit Period, Liquidated Damages, Firm prices if a bidder chooses not to give any cost of withdrawal of deviation (as per Annexure-VII), will apply. For any other deviation mentioned in un-priced copy of this format submitted with Part-1 bid but not mentioned in priced copy of this format submitted with Priced bid, the cost of withdrawal of deviation shall be taken as NIL.
- Any deviation mentioned in priced copy of this format, but not mentioned in the un-priced copy, shall not be considered.
- All techno-commercial terms and conditions of NIT shall be deemed to have been accepted by the bidder, other than those listed in unpriced copy of this format.
- Cost of withdrawal is to be given separately for each deviation. In no event bidder should club cost of withdrawal of more than one deviation else cost of withdrawal of such deviations which have been clubbed together shall be considered as NIL.
- In case nature of cost of withdrawal (positive/negative) is not specified it shall be assumed as positive.
- In case of discrepancy in the nature of impact (positive/negative), positive will be considered for evaluation and negative for ordering.



**KAHALGAON STPS (R&M) STAGE-1  
(4X210MW)  
HVAC SYSTEM**

**SPECIFICATION No: PE-TS-455-571- 15000A-  
A002**

**SECTION: II**

**SUB-SECTION : 6**

**REV. 00**

## **SECTION II**

### **SUB-SECTION: 6**

#### **Reference Drawing/Documents**

## 4x210 MW KAHALGAON STPS Stage-I

<b>Main Customer - National Thermal Power Corporation Limited</b>				
<b>Main Contractor - Bharat Heavy Electrical Ltd. ,Power Sector, PEM, Noida</b>				
<b>Sub Contractor - FFF Works</b>				
<b>SUB: INSPECTION CATEGORIZATION PLAN FOR AC PACKAGE</b>				
SL NO.	ITEM	MAKE	CATEGORY OF INSPECTION	Remarks
1	AIR COOLED DUCTABLE SPLIT AC	VOLTAS/BLUE STAR/CARRIER/HITACHI/LG	III	
2	AXIAL FANS / F.A. FANS	FLAKT / KHAITAN / PATEL / NICOTRA / SARLA / KRUGER / MARATHON / C DOCTOR/ ADVANCE/ HYDERABAD POLLUTION/ SK SYSTEM	III	
3	INDUCTION MOTORS (LT)	SIEMENS / ABB / CGL / MARATHON / KEC / BHARAT BIJLEE / NGEF / JYOTI / LHP / BHARAT ELECTRIC	III	
4	AIR FILTER	PUROLATOR / FMI / ANFILCO / TENACITY / JOHN FOWLER / SPECTRUM / AIR TECH / PUROMATIC	III	
5	FIRE DAMPER	TSC / CARRYAIRE / RAVISTAR (SYSTEM AIR )	III	
6	STRIP HEATER	ESCORTS / RACOLD / DASPASS/ ALCO/ HEATCO / HOTSET	III	
7	SPLIT AIR CONDITIONER	VOLTAS, BLUE STAR, CARRIER, HITACHI, LG	III	
8	INSULATION MATERIAL	BEARDSHELL / K-FLEX / PARAMONT / ARMAFLEX / SUPREME / LLOYDS / UP TWIGA/ AEROCELL	III	
11	G.I SHEET FOR DUCTING	TISCO / INDIAN IRON & STEEL CO LTD. / RASHITRYA ISPAT NIGAM LTD. / ESSAR/ ISPAT INDUSTRIES / JSW STEEL / LLOYDS STEEL / BHUSHAN / TATA / SAIL / JINDAL	III	
12	THERMOSTATS	HONEYWELL / RANCO / PENN / DANFOSS / INDFOSS / JHONSON CONTROL /RANUTROL	III	
13	HUMID STAT	JHONSON CONTROL / HONEYWELL / PENN	III	
14	PAN HUMIDIFIER	RAPID COOL/ HOTSET /ALCO	III	
15	PRESSURE GAUGE / DP GAUGE	GENERAL INST CONSORTIUM / BELL / H.GURU INST/ H GURU / WAAREE INSTRUMENTS / FORBES MARSHALL / MANOMETER / A.N. INST / GAUGES BOURDON / GLUCK / WIKA / ASHCROFT / BAUMER TECHNOLOGIES/ PRECISION MASS PRODUCTS/ BOSE PANDA INSTRUMENTS PVT. LTD.	III	
16	PRESSURE SWITCHES / DIFFERENTIAL PRESSURE SWITCH	BELLS / DANFOSS / DK INSTRUMENTS/ DRESSER / SOR INC / VASU / SWITZER / INDFOSS / TRAFAG / GIC / ASHCROFT / DELTA CONTROL/ KASTURBA UDYOG/ PRECISION MASS PRODUCTS/ MITTAL REFRIGERATION	III	
17	TEMPERATURE GAUGE	H.GURU IND/ H.GURU INST/ FORBES MARSHALL/DETRIVE INST & ELECTRONICS / PYRO ELECTRIC /TOSHNIWAL BROSS / WAREE INSTRUMENTS / A.N.INST / GOA INSTRUMENTS / WIKA / ASHCROFT / H GURU (SI) / BUDENBERG GUAGE CO.LTD./ GOA THERMOSTATIC INSTRUMENTS PVT.LTD./ GAUGE BOURDON INDIA PVT. LTD./BAUMER TECHNOLOGOIES INDIA PVT. LTD./ PRECISION MASS PRODUCTS.	III	
18	FLOW SWITCH	SWITZER / LEVCON / DK INSTRUMENT / SBEM / V. AUTOMATE/ SIEMENS	III	

<b>Main Customer - National Thermal Power Corporation Limited</b>				
<b>Main Contractor - Bharat Heavy Electrical Ltd. ,Power Sector, PEM, Noida</b>				
<b>Sub-Contractor - EFE Works</b>				
<b>SUB: INSPECTION CATEGORIZATION PLAN FOR AC PACKAGE</b>				

SL NO.	ITEM	MAKE	CATEGORY OF INSPECTION	Remarks
19	LEVEL SWITCH-	SBEM / BLISS ANAND / HI TECH / RAMAN INST / SIGMA / SOR INC / WAREE INST / LEVCON / DK INSTURMENT / V ATUOMATE /CHEMTROLS / SIMENS / FLOW STAR / TRAC/ FLOW TECH/ NIVO CONTROLS/ PUNE TECHTROL/ SAPCON INSTRUMENT/ BAUMER TECHNOLOGIES INDIA PVT. LTD./ GIC	III	
20	GRILL/DIFFUSER/VOLUME CONTROL DAMPER	AIR FLOW/ TSC /AIR MASTER/ CARYAIRE/RAVI STAR (SYSTEM AIR)	III	
21	POWER CABLE	CORDS/PARAMOUNT/UNIVERSAL CABLE/TORRENT/ <del>RADISON</del> /POLYCAB/NICCO/RADIANT CABLE/KEI/INCAB/HAVELS/HVPL/DELTON/R.R.KABLE/ <del>ELKAY TELELINK</del> /KEC INTERNATIONAL/ RAVIN CABLE/THERMOCABLES/SUYOG CABLES/SRI RAM CABLES/SBEE CABLES/ TIRUPATI PLASOMATICS/ADVANCE CABLE/FINOLEX CABLE/ GUPTA POWER/STEP INDUSTRIES/SCOTT INNOVATION WIRES & CABLES/	Refer Note 1 II	Manufacturing works location shall be as per NTPC accepted sources
22	CONTROL CABLE	CORDS CABLE/HVPL/GEMS CAB/KEI/RADIANT/ <del>RADISON</del> /ELKAY TELELINK/POLYCAB/NICCO/TORRENT/UNIVERSAL CABLE/DELTON/RR KABLE/PARAMOUNT CABLE/HAVELLS/GUPTA POWER/ <del>SPM CABLES</del> /RAVIN CABLES/SUYOG CABLES/INCAB/THERMOCABLES/TIRUPATI PLASOMATICS/ADVANCE CABLE/FINOLEX/KEC INTERNATIONAL/SBEE CABLES/STEP INDUSTRIES/ SCOTT INNOVATION WIRES AND CABLES	Refer Note 1 II	
23	RH SENSOR/TEMP SENSOR	HONEY WELL /JOHNSON /SIEMENS / GENERAL INSTRUMENTS	III	
24	GIU	SIEMENS / SCHENIEDER / ROCKWELL / GE INTELLIGENT / HONEYWELL AUTOMATION / ABB/ MITSUBISHI ELECTRIC	III	

<b>NOTE :-</b>
<b>Category-I:-</b> Most Critical Items: QAP will be submitted to BHEL /NTPC for approval. Inspection activities will be jointly witnessed by BHEL /TPA and NTPC as per approved QAP witness/hold points.
<b>Category-II:-</b> QAP will be submitted to BHEL /NTPC for approval. Inspection activities will be jointly witnessed by BHEL /TPA and witnessed by NTPC at their discretion as per approved QAP witness/hold points.
<b>Category-III:-</b> These are non QAP items and shall be accepted by BHEL /NTPC on the basis of review of manufacturer's test certificate/ certificate of compliance/internal inspection reports/guarantee certificate etc.However despatch clearance shall be issued by NTPC after reviewing manufacturer's test certificate/certificate of compliance/internal inspection report/guarantee certificate etc.

<p>Note 1:</p> <p><b>For Total Contract Quantity per Size</b></p> <p>For cable total quantity <math>\leq 2.5</math> KM :</p> <p>Conformance by Main Contractor for the manufacturers having successfully supplied to any NTPC project-site through Corporate contracts for atleast 2 years</p> <p>For cable total quantity above 2.5 km &amp; up to <math>\leq 10</math> km per size/type : Cat-II for the manufacturers having successfully supplied to any NTPC project-site through Corporate contracts for atleast 2 years</p> <p>For cable total quantity above 10 km per size/type :</p>	<p><b>Category Of Inspection</b></p> <p>Cat-III - submission of TC &amp; Certificate of</p> <p>Cat-I</p>
--	--

Sr No	Parameter	Unit	Value	
1	UNIT	Indoor unit model number	ACDEU55CZGIMC	
2		Outdoor unit model number	ACADS05512	
3		Power Supply ( to ODU)	Ph-V-Hz	3 Ph - 415 V - 50 Hz - 5 wire(R.Y.B.N.G)
4	PERFORMANCE	Actual Design Condition	TR	
5		Unit Rated Power Input	W	6719
6		Rated Current	A	11.0
7		Indoor Airflow		
8		High	CMH	3740
9		ESP @ High Speed SP/TP	mm WG	6/10.9
10	Compressor	Type	Hermetic Scroll	
11		Make	Voltas approved	
12		Qty / ODU	Nos	1
13		Rated Speed	RPM	2900
14		Vibration Isolator Type	Neoprene rubber grommets	
15	Indoor Fan Motor	Make	Voltas approved	
16		Power Output	W	600
17		Motor Speed (Lo / Med/ Hi)	RPM	1080/1140/1200
18	Indoor Coil	Number of Rows	nos	3
19		Fin Spacing	mm	1.95 (13 FPI)
20		Fin Type / Material		Aluminium / Hydrophillic Blue
21		Tube Diameter	mm	9.52
22		Tube Type / Material		Copper IGT
23	Blower Indoor Unit	Type of blower	Centrifugal DIDW, Forward curved	
24		Make of blower	Voltas approved	
25		No off Blowers	Nos	2
26	Indoor Unit Dimensions	Unit		
27		Length	mm	1228
28		Height	mm	404
29		Depth	mm	665
30		Packing		
31		Length	mm	1328
32		Height	mm	454
33	Depth	mm	715	
34	Outdoor Fan	Diameter	mm	600
35		Material		ABS Glass Filled Plastic
36	Outdoor Fan Motor	Make	Voltas approved	
37		Power Output	HP	0.5
38		Number of Motors / ODU	Nos	1
39		Type		AC Motor
40	Outdoor Coil	Type	nos	Air Cooled
41		Fin Spacing	mm	1.6 (16 FPI)
42		Fin Type / Material		Aluminium / Hydrophillic Blue
43		Tube Diameter	mm	9.52
44		Tube Type / Material		Copper IGT
45	Expansion Device	Type	TEV	
46		Make	Voltas approved	
47		Qty	mm	1
48	Outdoor Unit Dimensions	Unit		
49		Length	mm	950
50		Height	mm	960
51		Depth	mm	450
52		Packing		
53		Length	mm	1050
54		Height	mm	1010
55	Depth	mm	500	
56	REFRIGERANT	Refrigerant Type	R-407C	
57	Refrigerant Piping	Liquid Line Size	mm	12.7
58		Suction Line Size	mm	19
59		Discharge Line	mm	15.8
60	Filter	Make	Voltas approved	
62		Material of Filter	HDPE/Nylon Washable	
63		Material of Frame	MS	
64	Controller	Type	Wired Remote	
65		Remote (LCD / Non LCD)	LCD (Backlit)	
66		On/Off	Yes	
67		MODE: Cool	Yes	
68		MODE: Dry	Yes	
69		MODE: Fan	Yes	
70		MODE: Auto	Yes	
71		Temperature Setting	Yes	
72		24Hrs Timer ON/OFF	Yes	
73		Fan Speed	High/Med/Low	
74	Clock Setting	No		
75	Auto Re-Start	Yes		

voltage variation  
frequency variation  
& +3%

NOTES

- 1) THE RATED VALUES ARE AT INDOOR CONDITIONS OF 27 DBT/ 19 WBT AND OUTDOOR CONDITIONS OF 35 DBT / 24 WBT
- 2) PACKING AND WEIGHT DIMENSIONS ARE APPROXIMATE AND FOR INDICATION PURPOSE ONLY
- 3) INSPECTION AND TESTING AS PER APPROVED QAP.



SYSTEM DESIGN PARAMETER

a) The outside design conditions considered are as follows:

	Summer	Monsoon	Winter
DBT (°C)	43	38	7
WBT (°C)	27.5	29.5	5.8

b) The inside design conditions to be maintained are as follows:-

Temperature	:	24 ± 1°C
Relative humidity	:	50% ± 5%



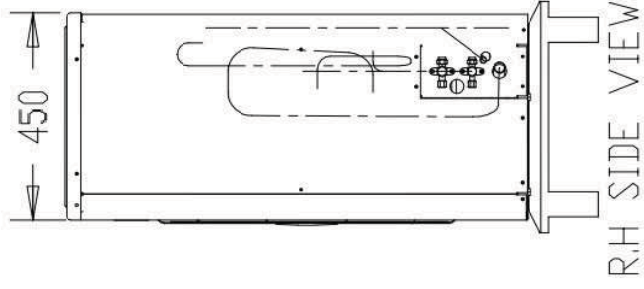
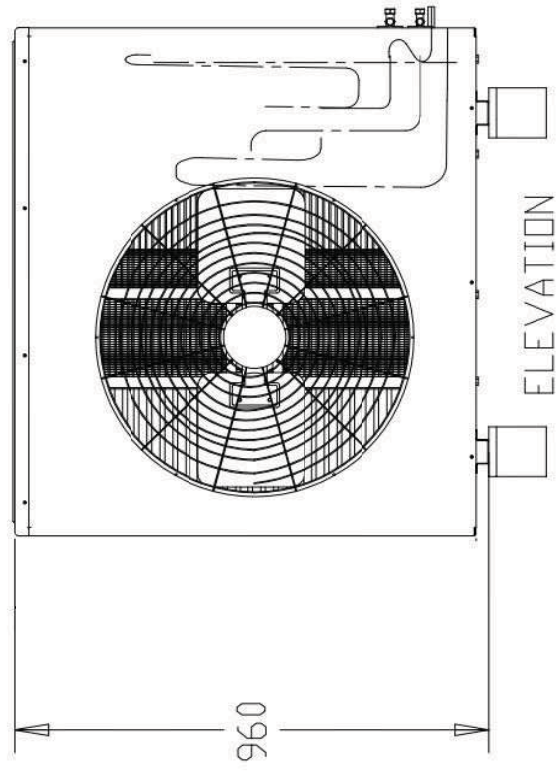
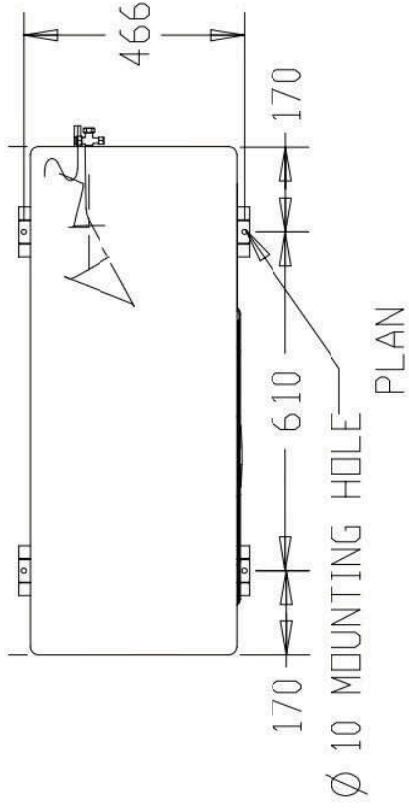

**VOLTAS LIMITED**

EMERGO/ENGG. THANE WORKS

MATERIAL

TITLE

**GA DWG OF ODU**

DWG SIZE

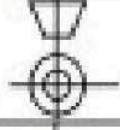

**TECHNICAL DATA - DUCTABLE SPLIT UNITS**

**FACTORY CHARGED UNITS**

A/C DUCTABLE SPLIT UNITS (R22/R407c)								
Nominal Capacity	TR	5.5 TR	8.5 TR	8.75 TR	11 TR	11 TR	17 TR	22 TR
Set Model no.- R22		ACADS05511	ACADS08721	ACADS08711	ACADS11021	ACADS11011	ACADS17021	ACADS22021
Set Model no.- R407c		ACADS05512	ACADS08722	ACADS08712	ACADS11022	ACADS11012	ACADS17022	ACADS22022
EVAPORATOR UNITS								
Airflow	CMH	3740	5780	5780	7480	7480	11560	14960
Evaporator Fan		Centrifugal Forward Curved Fan, Double Inlet Double Width						
Power Supply	V/Ph/Hz	230V • 1PH • 50Hz (2 Wire, AC Supply)						
Dimensions (L x D x H)	mm	1228 x 665 x 404	1508 x 795 x 404	1508 x 795 x 404	1820 x 780 x 475	1820 x 780 x 475	2020 x 750 x 575	2100 x 1240 x 640
Net weight	kg	64	81	88	112	117	181	292
AIR-COOLED CONDENSING UNITS								
No. of Units/Set		1	1	1	2	1	2	2
No. of Compressors/CU		1	2	1	1	1	1	1
Compressor Type		Hermetic Scroll						
Power Supply	V/Ph/Hz	415V • 3PH • 50Hz (4 Wire, AC Supply)						
Condenser fan		Axial	Axial	Axial	Axial	Axial	Axial	Axial
No. of Fans/CU		1	1	1	1	2	1	2
Dimensions/CU (L x D x H)	mm	950 x 450 x 960	1320 x 460 x 960	1200 x 450 x 960	950 x 450 x 960	1550 x 575 x 960	1200 x 450 x 960	1550 x 575 x 960
Net weight/CU	kg	120	155	137	120	170	137	170
Liquid Line Size	mm	12.7	9.52	15.8	12.7	15.8	15.8	15.8
Suction Line Size	mm	19	12.7	28.5	19	28.5	28.5	28.5
MCB Rating	A	32	50	50	63	63	100 SFU / MCCB	125 SFU / MCCB
Cable Size (Material)- Incomer	Sq.mm	4C x 6 (Cu) 4C x 10 (Al)	4C x 10 (Cu) 4C x 16 (Al)	4C x 10 (Cu) 4C x 16 (Al)	4C x 16 (Cu) 3.5C x 25 (Al)	4C x 16 (Cu) 3.5C x 25 (Al)	3.5C x 25 (Cu) 3.5C x 25 (Al)	3.5C x 35 (Cu) 3.5C x 50 (Al)
Cable Size (Material)- ODU to IDU	Sq.mm	3C x 1.5 (Cu)	3C x 1.5 (Cu)	3C x 1.5 (Cu)	3C x 1.5 (Cu)	3C x 1.5 (Cu)	3C x 1.5 (Cu)	3C x 1.5 (Cu)

W/C DUCTABLE SPLIT UNITS (R22/R407c)								
Nominal Capacity	TR	5.5 TR	-	8.75 TR	11 TR	-	17 TR	-
Set Model no.- R22		ACWDS05511	-	ACWDS08711	ACWDS11021	-	ACWDS17021	-
Set Model no.- R407c		ACWDS05512	-	ACWDS08712	ACWDS11022	-	ACWDS17022	-
EVAPORATOR UNITS								
Airflow	CMH	3740	-	5780	7480	-	11560	-
Evaporator Fan		Centrifugal Forward Curved Fan, Double Inlet Double Width						
Power Supply	V/Ph/Hz	230V • 1PH • 50Hz (2 Wire, AC Supply)						
Dimensions (L x D x H)	mm	1228 x 665 x 404	-	1508 x 795 x 404	1820 x 780 x 475	-	2020 x 750 x 575	-
Net weight	kg	65	-	88	117	-	181	-
WATER COOLED CONDENSING UNITS								
No. of Units/Set		1	-	1	2	-	2	-
No. of Compressors/CU		1	-	1	1	-	1	-
Compressor Type		Hermetic Scroll						
Power Supply		415V • 3PH • 50Hz (4 Wire, AC Supply)						
Condenser Water (In/Out)	in	1-1/4" BSP	-	1-1/4" BSP	1-1/4" BSP	-	1-1/4" BSP	-
Water Flow Rate/CU	LPM	73	-	113	73	-	113	-
Dimensions/CU (L x D x H)	mm	900 x 665 x 615	-	900 x 665 x 615	900 x 665 x 615	-	900 x 665 x 615	-
Net weight/CU	kg	155	-	170	155	-	170	-
Liquid Line Size	mm	12.7	-	15.8	12.7	-	15.8	-
Suction Line Size	mm	19	-	28.5	19	-	28.5	-
MCB Rating	A	25	-	50	50	-	100 SFU / MCCB	-
Cable Size (Material)- Incomer	Sq.mm	4C x 4 (Cu) 4C x 6 (Al)	-	4C x 10 (Cu) 4C x 16 (Al)	4C x 10 (Cu) 4C x 16 (Al)	-	3.5C x 25 (Cu) 3.5C x 25 (Al)	-
Cable Size (Material)- ODU to IDU	Sq.mm	3C x 1.5 (Cu)	-	3C x 1.5 (Cu)	3C x 1.5 (Cu)	-	3C x 1.5 (Cu)	-

- Notes:**
- The nominal capacities mentioned are at rating conditions of Indoor Temperature: 27°C DBT /19°C WBT and Outdoor Temperature: 35°C DBT for Air-cooled units & Cooling Water inlet temperature of 32°C for Water-cooled units.
  - Standard Air Cooled Units can operate upto maximum ambient temperature of 46°C.
  - The Gas charging at Factory is as per standard connection distance between ODU & IDU. For extra lengths, Gas topping up at site is required.
  - The piping sizes given are recommended for 7.5 m equivalent length between ODU & IDU. For longer piping lengths, please contact Voltas representative.
  - In addition to mentioned above, one more interlocking cable of size 3C x 1.5 sq mm is required between IDU & ODU.
  - Please contact VOLTAS sales representative for units below 5.5 TR capacity & Condensing Units with Microchannel Heat exchangers.

Product design and innovation is a continuous process in VOLTAS and hence the above specifications are subject to change without notice.

CONFERENCE HALLS

THEATRES

RESTAURANTS

1 NO.	5	FRESH AIR FANS	-	REF. DATA SHEET
25	Metre	DRAIN PIPE(40NB)	-	REF. DATA SHEET
LOT	3	DUCT SUPPORT	-	MS
2 NOS.	2	NON-RETURN DAMPER NRD1	720 x 380 (H)	REF. DATA SHEET
2 NOS. (1W+1S)	1	DUCTABLE SPLIT AC	CAP.-5.5 TR. (3740 CMH)	REF. DATA SHEET
QTY.	NO	DESCRIPTION	DIMENSION/TYPE	MATERIAL

BILL OF MATERIAL

INSULATION QTY.

S.NO	DESCRIPTION	QTY (Approx)
1.	ACOUSTIC	12 Sq.m
2.	THERMAL 50 MM THK.	55 Sq.m

SL.NO	NECK SIZE	S.A DIFFUSER WITH VCD	QTY
1.	300x300	595x595	10

DUCTING QTY.

S.NO	DESCRIPTION	SIZE	QTY (Approx)
1.	DUCT SHEET	24G	50 Sq.m

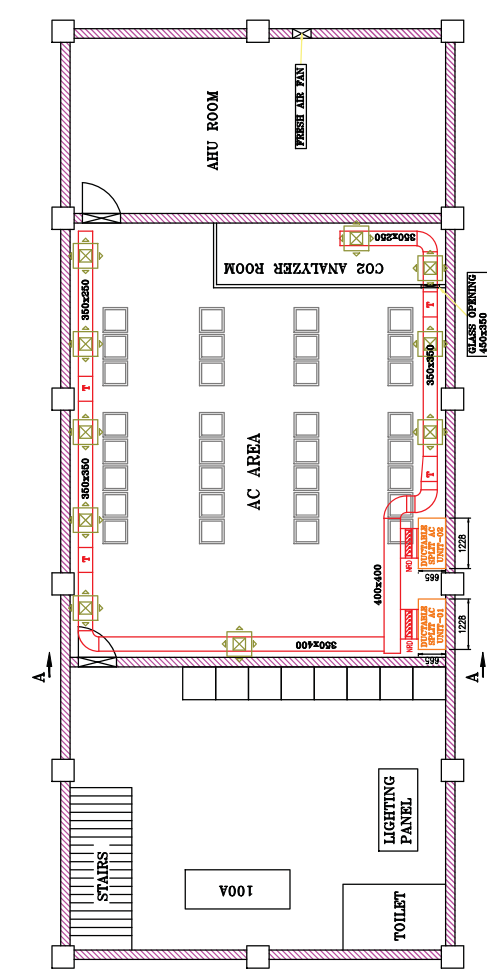

FIRST FLOOR

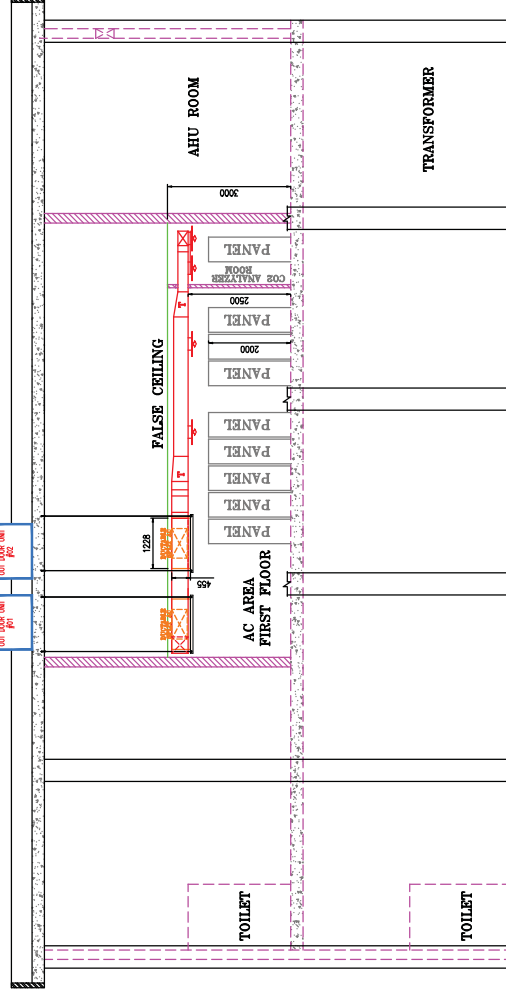

ELEVATION VIEW

**NOTE :-**

- 1) ALL DIMENSIONS ARE IN MM UNLESS OTHERWISE STATED.
- 2) DUCTING SHALL BE AS PER IS: 855. DUCT SHEET SHALL BE AS PER IS: 277, (275 GSM) CLASS-IV.
- 3) DUCT SUPPORT FROM CEILING/WALL TO SUIT AT SITE BY ANCHOR FASTENERS.
- 4) THERMAL & ACOUSTIC INSULATION SHALL BE AS PER SPECIFICATION.
- 5) NECESSARY SUITABLE VANES, SPLITTERS & DAMPER AS REQUIRED WILL BE PROVIDED.
- 6) MINOR MODIFICATIONS MAY BE CARRIED OUT TO SUIT AT SITE CONDITION.

CONTRACTOR: **BEER ROYERS**

BIBB. DOC. NO.: **PE-V0-455-571-15000A-A005**

NTPC DOC. NO.: **4210-104A-01-PYM-050**

CUSTOMER: **NTPC LIMITED**

PROJECT: **4X210MW KHAJGAON**

**ESP CONTROL ROOM - R&M**

**BHARAT HEAVY ELECTRICALS LTD**

PROJECT ENGINEERING MANAGEMENT

NOIDA

DATE: **12.08.2024**

DRW: **AK**

CHECKED: **AK**

APPROVED: **AK**

SCALE: **AS SHOWN**

DRAWING NO.: **4210-104A-01-PYM-050**

SHEET: **01** OF **02**

TITLE: **LAYOUT OF AC IN CONTROL ROOM**

Ventilation Calculation Sheet

Kahalgaoon ESP R&M- Each Unit

Dimensions in metre

SI No.	Description/Area	Length	Width	Height	ACPH	Capacity**	Selected Equipment	Qty. (Nos.)	Remarks
1	Switchgear Room First Floor- Supply Air Fan	6.4	9.2	6	30	10598	7500 CMH / 30MMSP	2	Exhaust through Gravity damper
2	Switchgear Room Ground Floor- Supply Air Fan	17.6	9	3.5	30	16632	7500 CMH / 30MMSP	3	Exhaust through Gravity damper
3	Toilet First Floor- Propeller type fan	1.6	2.5	6	20	480	1200CMH/5MMSP	1	
4	Toilet Grund Floor- Propeller type fan	1.6	2.2	4.5	20	317	1200CMH/5MMSP	1	

\*Capacity in CMH  
Air Change Per Hour (ACPH)

**SUBURBAN INDUSTRIAL WORKS PVT. LTD.**

CLIENT'S NAME / SITE WORK : PROJECT : KAHALGAON



DATE: 14/09/2021

**TECHNICAL DATA SHEET OF TUBE AXIAL FAN**

SL. NO.			1	
1	QUANTITY	Nos.	20	5 for each unit
2	MANUFACTURER		SARLA	
3	FAN MODEL		<b>TLJ-710</b>	
4	DESCRIPTION		TUBE AXIAL FAN	
5	IMPELLER TYPE		AEROFOIL	
6	REQUIRED AIR VOLUME	CMH	7500	
7	STATIC PRESSURE	MM. WG.	30	
8	FAN SPEED	RPM	1440	
9	FAN POWER	BKW	1.04	
10	MOTOR POWER	KW/P	1.5/4	
11	MOTOR FRAME		90L	
12	MOTOR TYPE		TEFC SQ. CAGE MOTOR, CLASS OF INSULATION - F	
13	ELECTRICAL SUPPLY		415 V $\pm$ 10%, 50 HZ $\pm$ 5%, 3 PHASE AC SUPPLY	
14	MOTOR SPEED (SYND.)	RPM	1500	
15	IMPELLER DIAMETER	MM	710	
16	TOTAL EFFICIENCY	%	62.5	
17	NOISE LEVEL @ 1.5 MTR. DISTANCE	dB(A)	80	
18	IMPELLER MATERIAL (INCLUDING HUB)		CAST ALUMINIUM MATERIAL, GRADE-LM-6	
19	OUTLET VELOCITY	MPS	5.30	
20	STARTER TYPE		DOL	
21	PAINTING TYPE		COMPLETE FAN CASING SHALL BE PAINTED WITH SYNTHETIC ENAMEL PAINT OVER TWO COATS OF RED OXIDE PRIMER.	

For all the steel surfaces (external) exposed to atmosphere (outdoor installation): one(1) coat of red oxide primer of thickness 30 to 35 microns followed up with three (3) coats of synthetic enamel paint, with 25 microns as thickness of each coat, shall be applied.

For all the steel surfaces inside the building (indoor installation): One (1) Coat of red oxide primer of thickness 30 to 35 microns followed up with two (2) coats synthetic enamel paint, with 25 microns as thickness of each coat shall be applied.

For all the steel surfaces (external) exposed to atmosphere (outdoor installation): one(1) coat of red oxide primer of thickness 30 to 35 microns followed up with three (3) coats of synthetic enamel paint, with 25 microns as thickness of each coat, shall be applied.

For all the steel surfaces inside the building (indoor installation): One (1) Coat of red oxide primer of thickness 30 to 35 microns followed up with two (2) coats synthetic enamel paint, with 25 microns as thickness of each coat shall be applied.

**TECHNICAL DATA**

SL. NO.	Manufacturer	SUBURBAN INDUSTRIAL WORKS PVT. LTD.
1.	Model / Nomenclature	TLJ-710/"SARLA"
2.	Quantity	20 Nos.
3.	Impeller Dia	710 MM
4.	Type of Blade	Aerofoil Type
(a)	Capacity in CMH	7500
5.	Static Pressure mm. WG.	30
6.	Fan Speed - RPM	1440
7.	Fan Total Efficiency - %	62.5
8.	Shaft Power in KW	1.04
9.	Material of Construction	MILD STEEL / 3.00 MM
(a)	Fan Casing-Material / Thickness in MM.	Cast AL., LM-6
(b)	Impeller Material	
11.	Motor Data (MOTOR IS NOT IN OUR SCOPE)	
(a)	Type of Motor	STD. TEFC SQ. CAGE INDUCTION MOTOR 415V, ±10%, 50 Hz, 3 Ph, AC Supply
(b)	Rating of Motor in KW/P	1.5 KW/4 Pole(Frame-90L)
(c)	Motor Speed (Synchronised)	1500
(d)	Insulation Class	F
(e)	Protection	IP:55
13.	Fan Balancing	Dynamically Balanced As per ISO:1940,5.6.3.
14.	Painting	Complete Fan Casing shall be Painted with Synthetic Enamel PAINT over two coats of Red Oxide Primer.

12.	AIR INTAKE LOUVER	1 NO.	MS
11.	FINE FILTER(WITH FRAME)	1 NO.	MS
10.	PRE FILTER(WITH FRAME)	1 NO.	MS
09.	ADOPTER SECTION	1 NO.	MS
08.	COWL WITH BIRD SCREEN	1 NO.	MS
07.	SUPPORTING STRUCTURE	1 SET	MS
06.	MOUNTING LEGS	2NOS.	MS IS: 2062/1079
05.	IMPELLER RETAINING WASHER	1 NO.	MS IS: 2062/1079
04.	MOTOR	1 NO.	BY ABB
03.	MOTOR BASE	1 NO.	MS IS: 2062/1079
02.	IMPELLER	1 NO.	AL LM-6
01.	FAN CASING	1 NO.	MS IS: 2062/1079
SL.	DESCRIPTION	QTY.	MATL. REFERENCE

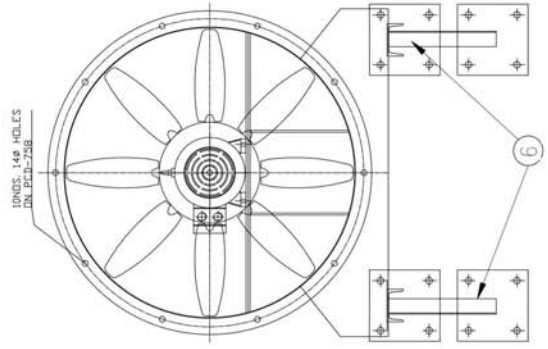

**DRIVE END VIEW**

NO. OF BLADES SHOWN ARE PICTORIAL ONLY  
ACTUAL NO. OF BLADE VARIED AS PER SELECTION

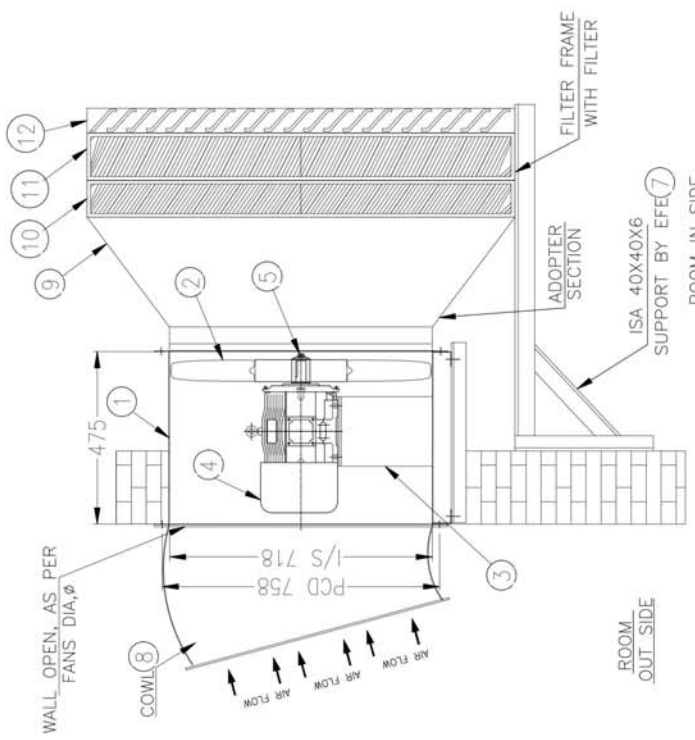

**ELEVATION**  
**SUPPLY SYSTEM**

- NOTE:-**
- ALL DIMENSIONS ARE IN MM. UNLESS OTHERWISE STATED.
  - FAN WILL BE STATICALLY & DYNAMICALLY BALANCED TO GR.:G8.3 AS PER ISO 1940.
  - FAN CONSTRUCTION CONFIRMING AS PER IS:1079. (LATEST)
  - NOISE LEVEL 85 DBA AT 1 MT. AWAY FROM FAN AS PER IS: 12065-1987
  - MECHANICAL VIBRATION OF THE FAN & MOTOR UNIT SHALL BE RESTRICTED ACCORDING TO THE RELEVANT CLAUSES OF ISO 10816-1-1995 (E).
  - PAINTING SHALL BE AS PER SPECIFICATION.
  - THE TUBE AXIAL FANS SHALL BE OF VARIABLE PITCH TYPE.
  - FAN MANUFACTURING AND TESTING SHALL BE AS PER IS 3588-1987
  - FAN WALL CUTOUT AS PER FAN INSIDE DIAMETER BASIS.
  - FAN CONSTRUCTION AS PER CONFIRMING AS PER IS 3588:1987
  - VIBRATION LIMITED AS PER ISO 14694-2003. (MAX- 4.5M/SEC)
  - MOTOR DEGREE OF PROTECTION OF IP - 55.
  - MOTOR CLASS OF INSULATION - F
  - MOTOR EFFICIENCY CLASS- IE-3.
  - WALL OPEN, REQ 720 mm FOR FAN FIXING.



**PROJECT : KAHALGAON**

**SIWENT FAN CHARACTERISTIC CURVE**

FAN MODEL- TLJ-710

VOLUME OF AIR (CMH)	7500	FAN SPEED (RPM)	1440
STATIC PRESSURE (MM. WG.)	30	FAN POWER (KW)	1.04





ABB Motors and Generators		Technical Data Sheet			
		Project	Location		
Department/Author		Customer name	Customer ref.		Item name
Our ref.		Rev/Changed by	Date of issue	Saving ident	Pages
		A	1/18/2019	untitled.xls	1.00001 1(3)
No.	Definition	Data	Unit	Remarks	
1	Product	<i>TEFC, 3-phase, squirrel cage induction motor</i>			
2	Product code	3GBA 092 010-ASDIN		Calc. ref.	3GZH021009-2
3	Type/Frame	M2BAX 90SLA 4			
4	Mounting	IM1001, B3(foot)			
5	Rated output P <sub>N</sub>	1.5	kW		
6	Service factor	1			
7	Type of duty	S1 100%			
8	Rated voltage U <sub>N</sub>	415	VY	+10, -10 %	
9	Rated frequency f <sub>N</sub>	50	Hz	+5, -5 %	
10	Rated speed n <sub>N</sub>	1431	r/min		
11	Rated current I <sub>N</sub>	3.5	A		
12					
13	Starting current I <sub>g</sub> /I <sub>N</sub>	6			
14	Nominal torque T <sub>N</sub>	10	Nm		
15	Locked rotor torque T <sub>s</sub> /T <sub>N</sub>	3.5			
16	Maximum torque T <sub>max</sub> /T <sub>N</sub>	3.9			
17					
18					
Load characteristics		Load %	Current A	Efficiency %	Power factor
19	PLL determined from residual loss	100	3.5	85.3 / IE3	0.75
20		75	2.8	85.2	0.66
21		50	2.5	82.9	0.5
22					
23	Thermal withstand time hot	7	s		
24	Thermal withstand time cold	12	s		
25	Insulation class / Temperature class	F / B			
26	Ambient temperature	50			maximum temp rise 70 deg. above 50 deg. ambient.
27	Altitude	1000	m.a.s.l.		
28	Degree of protection	IP55			
29	Cooling system	IC411 self ventilated			
30	Bearing DE/NDE	6205-2Z/C3 - 6204-2Z/C3			
31	Sound pressure level (LP dB(A) 1m)	64	dB(A)	at no-load	
32	Moment of inertia J = ¼ GD2	0.00486	kg-m2		
33	Position of terminal box	Top			
34	Direction of rotation	Bi-directional			
35	Weight of rotor	6	kg		
36	Total weight of motor	25	kg		
37					
38					
39					
40					
41					
42					
43					
44					
45					
Ex-motors					
46					
47					
48					
Option Variant Codes / Definition					
49					
50					
51					
52					
Remarks:					
Data based on situation 12/21/2015					

All performance values are subject to IS/IEC tolerances



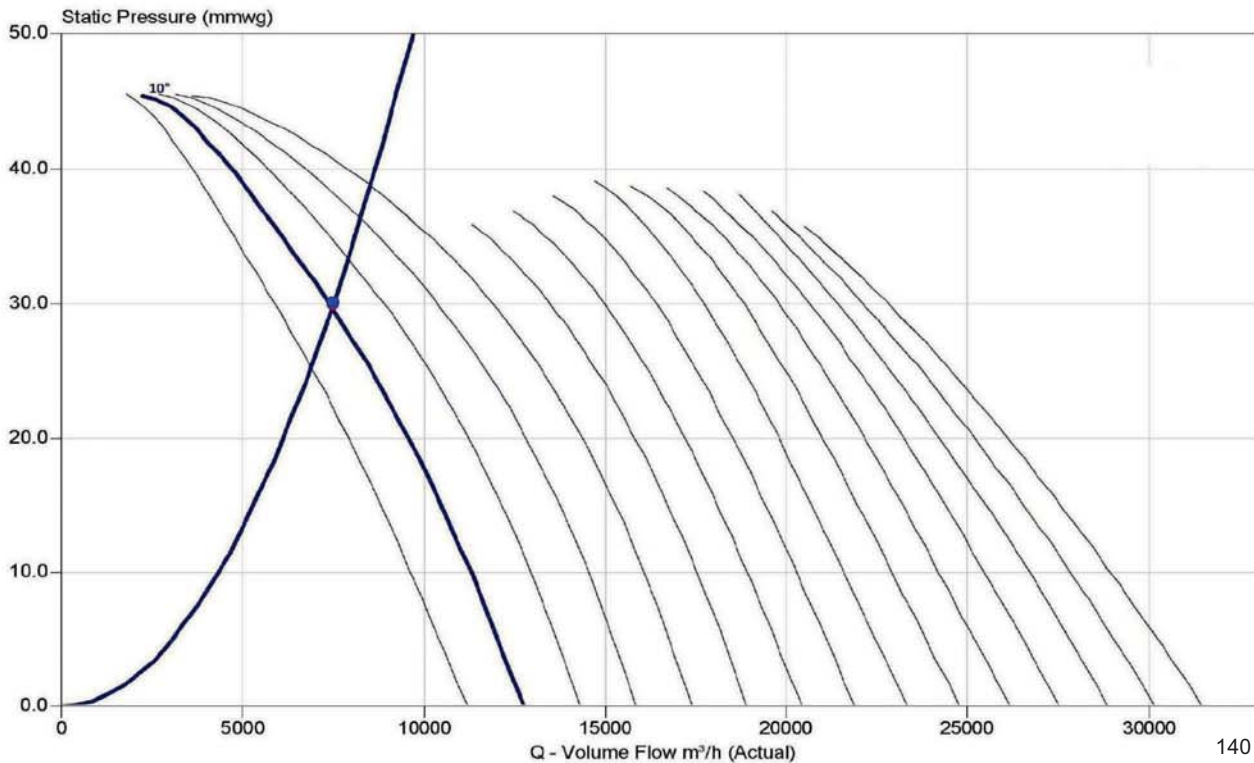
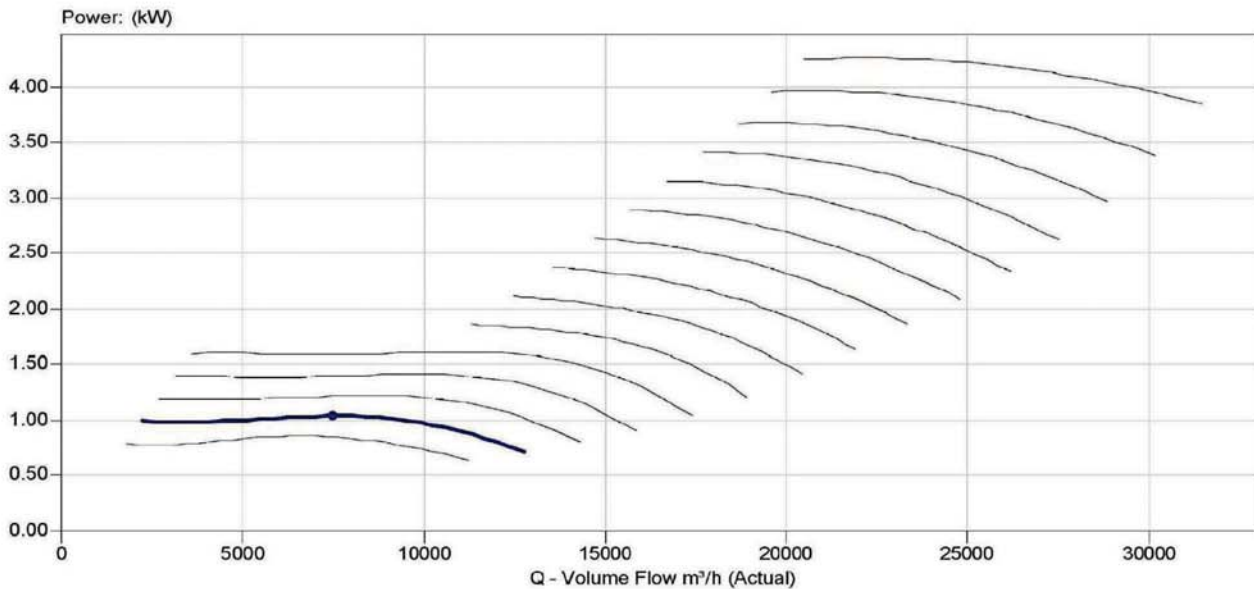

ABB Motors and Generators	Starting Curves		
	Project	Location	
Department/Author	Customer name	Customer ref.	Item name <b>1.00001</b>
Our ref.	Rev/Changed b Date of issue <b>A 1/18/2019</b>	Saving ident <b>untitled.xls</b>	Pages <b>3(3)</b>
Type of product	<b>TEFC, 3-phase, squirrel cage induction motor</b>		
Type/Frame	<b>M2BAX 90SLA 4</b>	Calc. ref.	<b>3GZH021009-2</b>
Product code	<b>3GBA 092 010-ASDIN</b>	Frequency (Hz)	<b>50</b>
Rated output P <sub>N</sub>	<b>1.5 kW</b>	Rated current I <sub>N</sub>	<b>3.5 A</b>
Type of duty	<b>S1 100%</b>		
J <sub>motor</sub> (kgm <sup>2</sup> )	<b>0.0049</b>	Voltage (V) 100%	<b>415</b> Voltage (V) <b>415V(100%)</b>
J <sub>load</sub> (kgm <sup>2</sup> )		T <sub>start</sub> /T <sub>N</sub>	<b>3.5</b> T <sub>start</sub> /T <sub>N</sub> <b>3.5</b>
Speed (r/min)	<b>1431</b>	Starting time (s)	
T <sub>N</sub> (Nm)	<b>10</b>	Speed (r/min)	<b>939</b>
T <sub>load</sub> (Nm)		I <sub>s</sub> /I <sub>n</sub>	<b>6</b> I <sub>s</sub> /I <sub>n</sub> <b>6</b>
		T <sub>max</sub> /T <sub>n</sub>	<b>3.9</b> T <sub>max</sub> /T <sub>n</sub> <b>3.9</b>

The graph plots torque (Ts/Tn) on the left y-axis (0 to 4.5) and current (Is/In) on the right y-axis (0 to 9) against speed (r/min) on the x-axis (0 to 1750). Two torque curves are shown: a solid blue line for TMotorUn 415V and a solid red line for TMotorU2 415V(100%). Two current curves are shown: a dashed purple line for IMotorUn 415V and a dashed green line for IMotorU2 415V(100%). The torque curves peak at approximately 3.9 around 939 r/min. The current curves peak at approximately 6 around 1431 r/min.

Data based on situation 12/21/2015  
All data subject to tolerances in accordance with IS/IEC 60034-1 : 2004

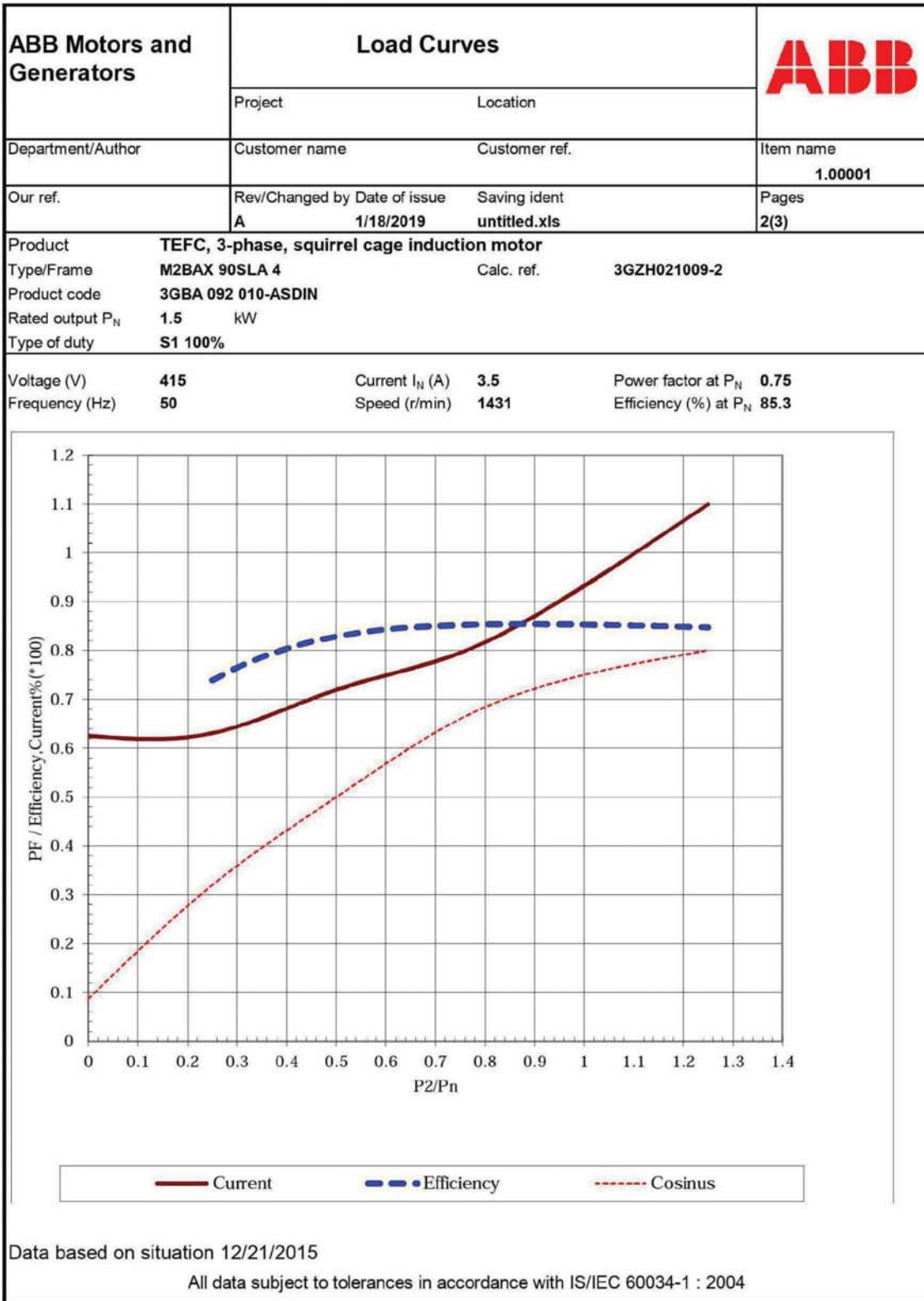
ABB Motors and Generators	Current & Speed Vs Time			
	Project	Location		
Department/Author	Customer name	Customer ref.	Item name <b>1.00001</b>	
Our ref.	Rev/Changed b Date of issue <b>A 1/18/2019</b>	Saving ident <b>untitled.xls</b>	Pages <b>4(3)</b>	
Type of product	<b>TEFC, 3-phase, squirrel cage induction motor</b>			
Type/Frame	<b>M2BAX 90SLA 4</b>	Calc. ref.	<b>3GZH021009-2</b>	
Product code	<b>3GBA 092 010-ASDIN</b>	Frequency (Hz)	<b>50</b>	
Rated output P <sub>N</sub>	<b>1.5 kW</b>	Rated current I <sub>N</sub>	<b>3.5</b>	<b>A</b>
Type of duty	<b>S1 100%</b>			
J <sub>motor</sub> (kgm <sup>2</sup> )	<b>0.0049</b>	Voltage (V) 100%	<b>415</b>	Voltage (V) <b>415V(100%)</b>
J <sub>load</sub> (kgm <sup>2</sup> )		T <sub>start</sub> /T <sub>N</sub>	<b>3.5</b>	T <sub>start</sub> /T <sub>N</sub> <b>3.5</b>
Speed (r/min)	<b>1431</b>	Starting time (s)		Starting time (s)
T <sub>N</sub> (Nm)	<b>10</b>	Speed (r/min)		Speed (r/min) <b>939</b>
T <sub>load</sub> (Nm)		I <sub>s</sub> /I <sub>n</sub>	<b>6</b>	I <sub>s</sub> /I <sub>n</sub> <b>6</b>
		T <sub>max</sub> /T <sub>n</sub>	<b>3.9</b>	T <sub>max</sub> /T <sub>n</sub> <b>3.9</b>

  

Starting Time [s]	Speed [rpm]	Current [A]
0.000	0	22
0.005	300	18
0.010	600	14
0.015	900	10
0.020	1200	6
0.023	1431	2

Data based on situation 12/21/2015  
All data subject to tolerances in accordance with IS/IEC 60034-1 : 2004

<b>ABB Motors and Generators</b>	<b>Thermal Withstand Curve</b>		
	Project	Location	
Department/Author	Customer name	Customer ref.	Item name <b>1.00001</b>
Our ref.	Rev/Changed b Date of issue <b>A 1/18/2019</b>	Saving ident <b>untitled.xls</b>	Pages <b>5(3)</b>
Type of product	<b>TEFC, 3-phase, squirrel cage induction motor</b>		
Type/Frame	<b>M2BAX 90SLA 4</b>	Calc. ref.	3GZH021009-2
Product code	<b>3GBA 092 010-ASDIN</b>	Frequency (Hz)	<b>50</b>
Rated output P <sub>N</sub>	<b>1.5 kW</b>	Rated current I <sub>N</sub>	<b>3.5 A</b>
Type of duty	<b>S1 100%</b>		

J <sub>motor</sub> (kgm <sup>2</sup> )	<b>0.0049</b>	Voltage (V) 100%	<b>415</b>	Voltage (V)	<b>415V(100%)</b>
J <sub>load</sub> (kgm <sup>2</sup> )		T <sub>start</sub> /T <sub>N</sub>	<b>3.5</b>	T <sub>start</sub> /T <sub>N</sub>	<b>3.5</b>
Speed (r/min)	<b>1431</b>	Starting time (s)		Starting time (s)	
T <sub>N</sub> (Nm)	<b>10</b>	Speed (r/min)		Speed (r/min)	<b>939</b>
T <sub>load</sub> (Nm)		I <sub>s</sub> /I <sub>n</sub>	<b>6</b>	I <sub>s</sub> /I <sub>n</sub>	<b>6</b>
		T <sub>max</sub> /T <sub>n</sub>	<b>3.9</b>	T <sub>max</sub> /T <sub>n</sub>	<b>3.9</b>

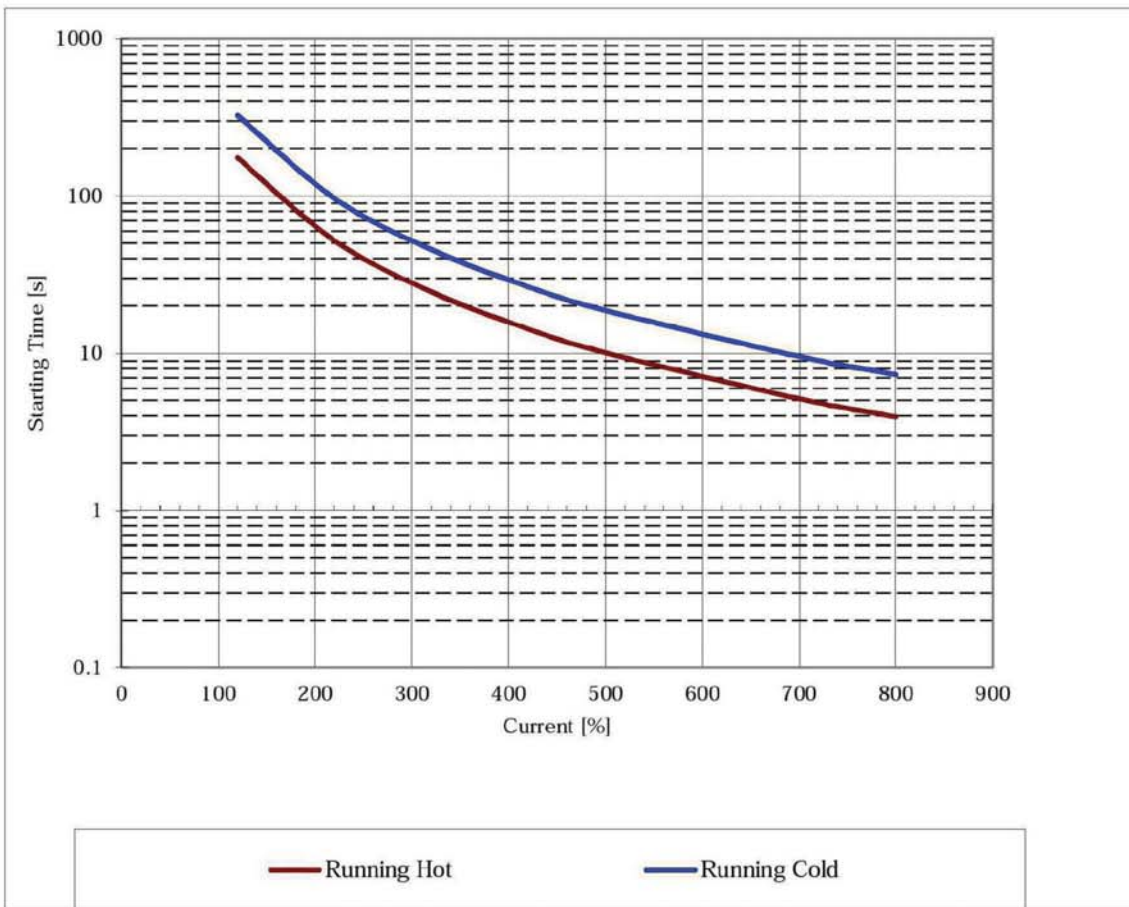

Data based on situation 12/21/2015

All data subject to tolerances in accordance with IS/IEC 60034-1 : 2004

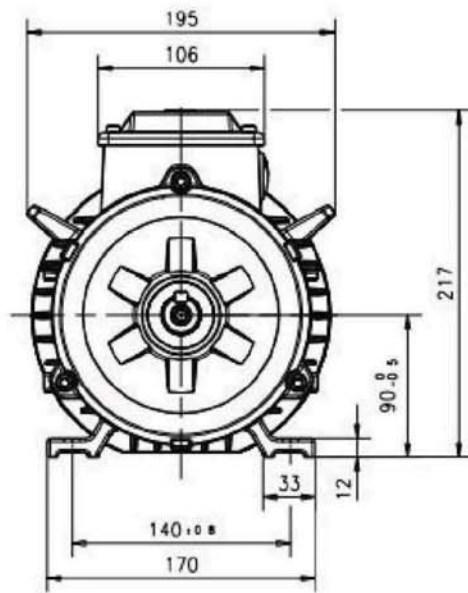
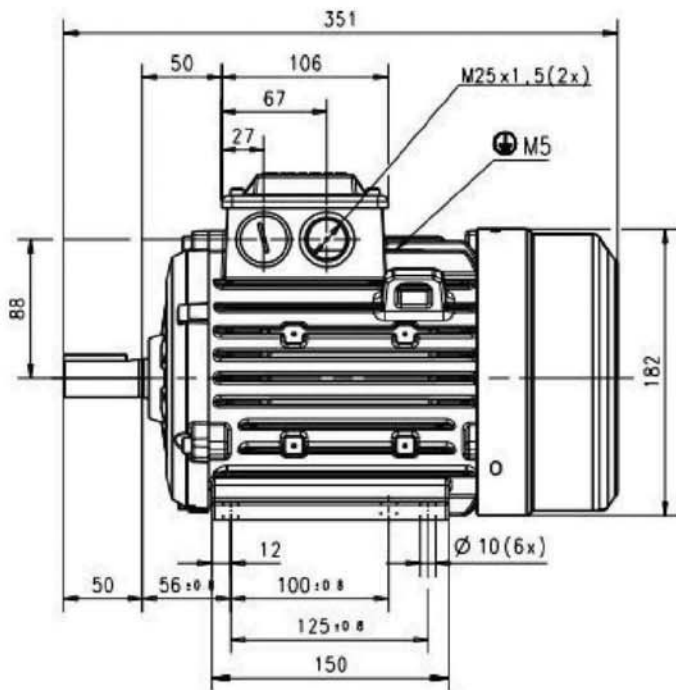
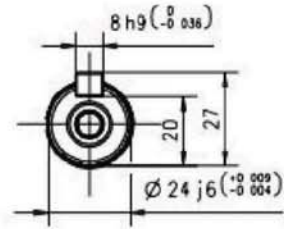
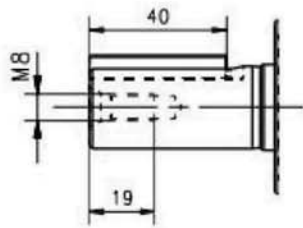

Additional Information:

**Dimension Print**

Motor Type:  
M2BAX 90 SL B3, V5, V6

Document No:  
3GZH500009-3 A

Description: STANDARD IE3 SQUIRREL CAGE MOTOR



Unit: ABB LV Motors, India.

Issued by: RKS

Replaces:

Date: 2015-12-08

Approved by: SA

Replaced by:

Customer Reference:



# PROPELLER FANS FOR TOILETS

## TECHNICAL SPECIFICATION FOR PROPELLER FAN

DUTY	MAKE/MODEL	QUANTITY	TYPE	CAPACITY (CMH)	STATIC PRESSURE (mm.WG.)	MOTOR STATIC WET	MOTOR DYNAMIC WET	TOTAL PRESSURE (mm.WG.)	POWER INPUT (watts)	RATED SPEED (RPM)	CRITICAL SPEED	VOLTAGE/PHASE	INSULATION CLASS
EXHAUST	MARATHON 300P	08 nos.	PROPELLER	1200 cmh	5mmwg.	15k.g	18.75k.g	FREE AIR DELEVRY	80 WATTS	1400	1520	220V-50HZ A.C FOR SINGLE PHASE	B

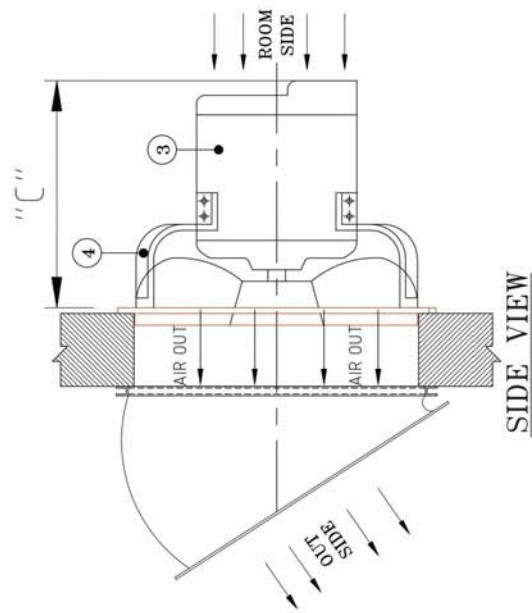
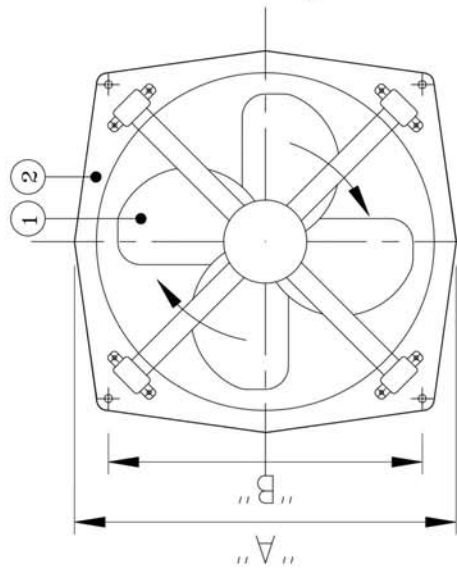

BILL OF MATERIAL

1	FAN BLADE	1MM THIK	CRCA	4NOS.
2	FAN MOUNTING RING		M.S.	1NO.
3	MOTOR SINGLE PHASE	220V STD	M.S.	4NOS.
4	MOTOR BRACKET		G.I	1NOS.

DIMENSIONS

Fan Model No	A mm	B mm	C mm	D mm
300P	384	315	327	270

NOTES:

1. ALL DIMENSION ARE IN MM.
2. MATERIAL OF CONSTRUCTION AS PER IS:2062 GR-A. & IS:1079 UNLESS OTHERWISE STATED
3. FAN WILL BE STATICALLY & DYNAMICALLY BALANCED TO GR:G6.3 AS PER ISO 1940.
4. FAN CONFORMS TO IS:2312-1967.
5. NOISE LEVEL OF FAN WITHIN 85 db(A) AT 1 METER DISTANCE FROM FAN.
6. PAINTING SHALL BE DONE AS PER GTS.
7. PROPELLER FAN CONFIRM TO IS2312-1967 (REFERRED 1994).

75x75x100 DEEP POCKET

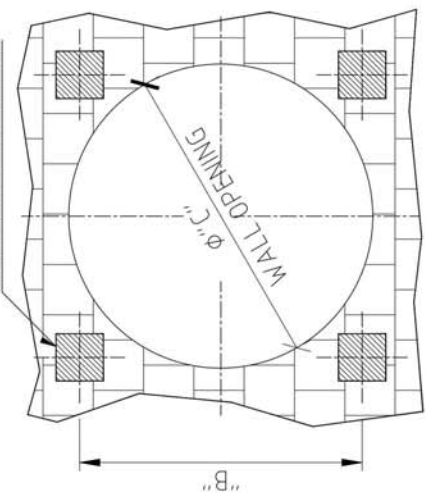

CONFIDENTIAL

DATE	REV.	DESCRIPTION	DESIGNED	CHECK	APPR.	DATE

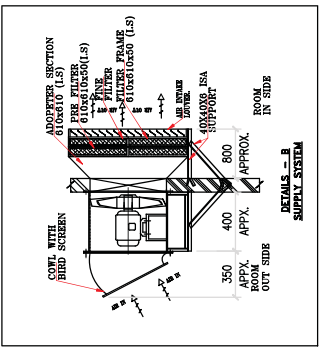
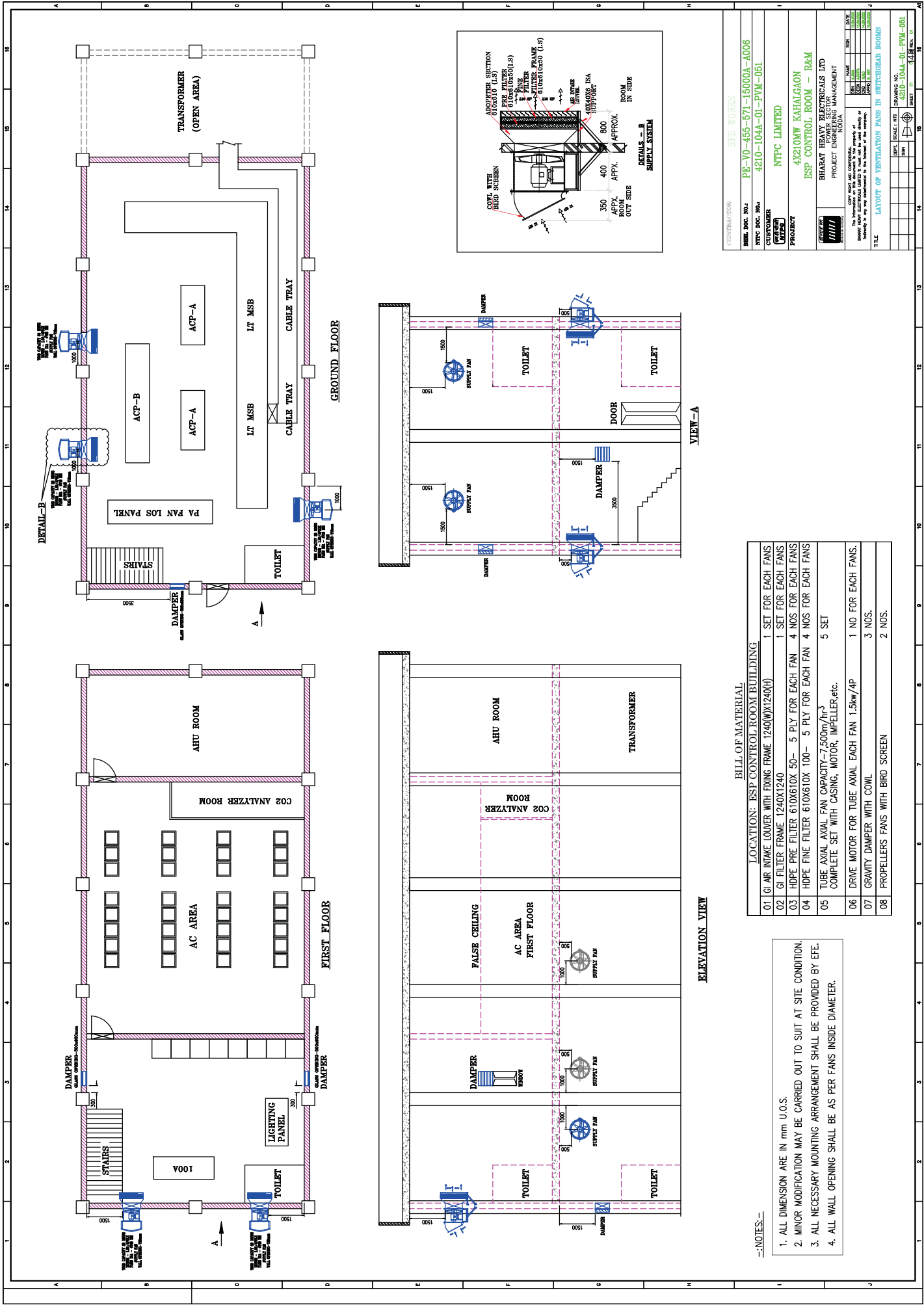

CONTROL ROOM

PE-V0-465-571-15000A-4006  
 4210-104A-01-PVM-051

CUSTOMER  
**NTPC LIMITED**

PROJECT  
**4X210MW KAHALGAON  
 ESP CONTROL ROOM - R&M**

DESIGNER  
**BHARAT HEAVY ELECTRICALS LTD  
 PROJECT ENGINEERING MANAGEMENT  
 NOIDA**

DATE: 05/01/2024  
 TIME: 09:00 AM  
 DRAWING NO. 4210-104A-01-PVM-051  
 SHEET NO. 01 OF 01

TITLE **LAYOUT OF VENTILATION FANS IN SWITCHGEAR ROOMS**

BILL OF MATERIAL

LOCATION: ESP CONTROL ROOM BUILDING

01	GI AIR INTAKE LOUVER WITH FIXING FRAME 1240(W)x1240(H)	1 SET FOR EACH FANS
02	GI FILTER FRAME 1240X1240	1 SET FOR EACH FANS
03	HDPE PRE FILTER 610X610X 50- 5 PLY FOR EACH FAN	4 NOS FOR EACH FANS
04	HDPE FINE FILTER 610X610X 100- 5 PLY FOR EACH FAN	4 NOS FOR EACH FANS
05	TUBE AXIAL AXIAL FAN CAPACITY-7.500m <sup>3</sup> /hr <sup>3</sup> COMPLETE SET WITH CASING, MOTOR, IMPELLER, etc.	5 SET
06	DRIVE MOTOR FOR TUBE AXIAL EACH FAN 1.5kw/4P	1 NO FOR EACH FANS.
07	GRAVITY DAMPER WITH COWL	3 NOS.
08	PROPELLERS FANS WITH BIRD SCREEN	2 NOS.

- NOTES:-
1. ALL DIMENSION ARE IN mm U.O.S.
  2. MINOR MODIFICATION MAY BE CARRIED OUT TO SUIT AT SITE CONDITION.
  3. ALL NECESSARY MOUNTING ARRANGEMENT SHALL BE PROVIDED BY EFE.
  4. ALL WALL OPENING SHALL BE AS PER FANS INSIDE DIAMETER.

QTY. - 4NOs

**NOTES**

1. ALL DIMENSION ARE IN M.M. SUBJECT TO TOLERANCE OF ±8mm
2. ALL SHEET METAL WORKS ARE OF 14 SWG(2mm) THK. CRCA SHEET STEEL  
DOORS & COVERS - 16 SWG(1.6mm) GLAND PLATE-3mm THK.
3. DEGREE OF PROTECTION -IP-54 AS PER IS 2147
4. THE ENCLOSURE(BOTH INSIDE & OUTSIDE) SHALL BE POWDER COATED PAINTED AS PER SHADE RAL 7032 AFTER NECESSARY PRETREATMENTS ON SHEET STEEL
5. ALL OPENINGS WILL BE COVERED WITH SOFT NEOPRENE RUBBER GASKET
6. MAIN BUS - 30X10mm ALU FOR R,Y,B,N
7. ALL BUSBAR INSULATING SUPPORTS SHALL BE DMC MOULDED NON HYGROSCOPIC SUPPORTS.  
MAIN BUSBARS SUITABLE FOR 25KA/SEC.
8. CONTROL WIRING SHALL BE DONE WITH 1100V GRADE 1.55sq.mm  
PVC INSULATED MULTISTRAND FLEXIBLE CU CABLE (GREY COLOURED)
9. CABLE ENTRY FROM BOTTOM
10. BUS BAR SHALL BE INSULATED WITH HEAT SHRUNK PVC SLEEVE WITH INTERMITTENT COLOUR BAND (R,Y,B)
11. LEGEND SHALL BE ENGRAVED ON BLACK ANODISED ALU. PLATE.

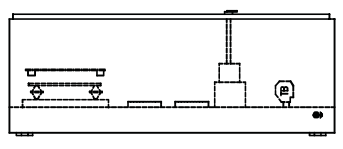

**SIDE VIEW**

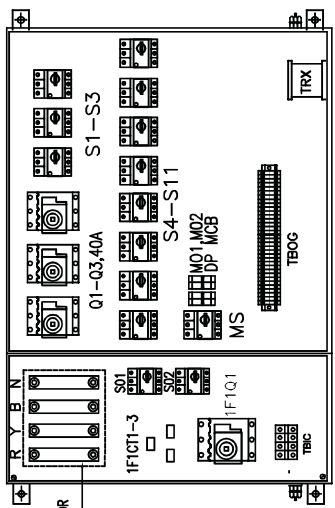

**FRONT VIEW WITHOUT COVER**

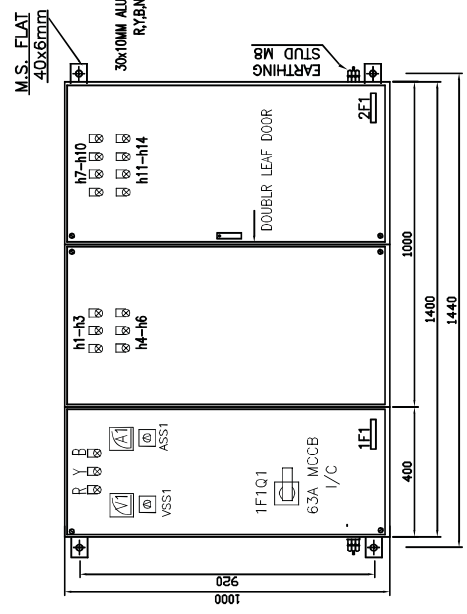

**FRONT VIEW WITH COVER**

- 1F1 - INCOMER (63A MCCB)
- 2F1 - 3NOS. 40A 4P MCCB FEEDER (h1-h3)
- 3NOS. 6.3A 1P MPCB FEEDER (h4-h6)
- FRESH AIR FAN (0.37KW) (h7)
- SPARE (0.37KW) (h8)
- TUBE AXIAL FAN-1 (h9)
- TUBE AXIAL FAN-2 (h10)
- TUBE AXIAL FAN-3 (h11)
- TUBE AXIAL FAN-4 (h12)
- TUBE AXIAL FAN-5 (h13)
- TUBE AXIAL FAN-6 (h14)

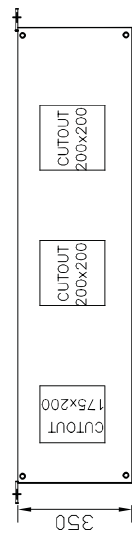

**FOUNDATION PLAN**

**MAIN NAME PLATE**

ACDB

**LEGEND DETAILS**

h1-h14 - ON

PROJECT :	KAHELGAON PROJECT
CUSTOMER :	NTPC LIMITED
CONTRACTOR :	BHARAT HEAVY ELECTRICALS LTD. POWER SECTOR PROJECTS ENGINEERING MANAGEMENT INDIA
HVAC CONTRACTOR :	SEE WORKS KOLKATA, INDIA
DESIGN BY	
CHECKED BY	
APPROVED BY	
SUPERSEDES BY	
TITLE:-- GENERAL ARRANGEMENT DIAGRAM OF ACDB	
SIZE :	PROJECT NO. :
ANNEX :	DRAWING NO. :
	SHEET NO. : 1 OF 1
	REVOUT

1 2 3 4 5 6 7 8

DO NOT SCALE, ASK IF IN DOUBT

Note: Make of components/vendor shall be NTPC OA approved

SL. NO.	NOMEN	DESCRIPTION	MAKE	TYPE	RATING	QTY
<b>INCOMER -FDR-2F1 &amp; CONTROL TRX</b>						
01	1F1Q1	TP MCCB, 25KA, WITH S/C , O/L RELEASE & DOOR INTERLOCK	L&T	DN0-100C CM9161200H006	63A	1
02	1F1CT1-3	CURRENT TRAF0 CLASS-1 ( RESIN CAST)	KAPPA	RING	60/5A,5VA	3
03	A1	AMMETER (96x96) CTR:60/5A CL-1	AE	SIF96	0-60A	1
04	ASS1	AMMETER SELECTOR SWITCH	KAYGEE	SRP136MA60	10A	1
05	V1	VOLTMETER (96x96)	AE	SIF96	0-500V	1
06	VSS1	VOLTMETER SELECTOR SWITCH	KAYGEE	SRP135VS	10A	1
07	R.Y.B	PHASE INDICATING LAMP (R,Y,B) CLUSTERED LED TYPE	L&T	EPL	240V AC	3
08	S01-S02,MS	TP MPCB WITH O/L & S/C RELEASE	L&T	ST419110000	4A	3
09	Q1-Q3	4POLE MCCB WITH O/L & S/C RELEASE (25KA)	L&T	DN0100C CM9171200F006	40A	3
10	S1-S5	TP MPCB WITH O/L & S/C RELEASE	L&T	ST419120000	6.3A	5
11	S6-S11	TP MPCB WITH O/L & S/C RELEASE	L&T	ST419150000	16A	6
12	MD1,MD2	DP MCB, 'C' Curve, 10kA	L&T	BB20020C	2A	2
13	TRX	CONTROL TRAF0 (415V/24V AC) Cu wound,PI, ±2.5%,±5% TAPPING ON PRIMARY SIDE	INDUSFREE	AIR COOLED	100VA	1
14	h1-h14	INDICATING LAMP (RED) CLUSTERED LED TYPE	L&T	EPL	240V AC	14
15	TBIC	STUD TYPE TERMINAL FOR INCOMING TERMINATION	ELMEX	KATM5	800V,76A	5
16	TBOG	STUD TYPE TERMINAL FOR OUTGOING TERMINATION	ELMEX	KATM3	800V,24A	60
17	TB	CLIP ON TYPE TERMINAL	ELMEX	KUT2.5	800V,24A	5

<b>PROJECT :</b>	KAHELGAON PROJECT
<b>CUSTOMER :</b>	NTPC LIMITED
<b>CONTRACTOR :</b>	BHARAT HEAVY ELECTRICALS LTD. PROJECTS ENGINEERING MANAGEMENT INDIA.
<b>CONTRACTOR :</b>	EFFE WORKS KOLKATA, INDIA
<b>DESIGN BY</b>	
<b>CHECKED BY</b>	
<b>APPROVED BY</b>	
<b>ISSUED BY</b>	
<b>REVISIONS BY</b>	
<b>DATE</b>	
<b>TITLE :-</b>	BILL OF MATERIALS OF ACDB
<b>SIZE :</b>	PROJECT NO. : 1 OF 1
<b>ANNEX :</b>	DRAWING NO. :
<b>REV#1</b>	

1 2 3 4 5 6 7 8

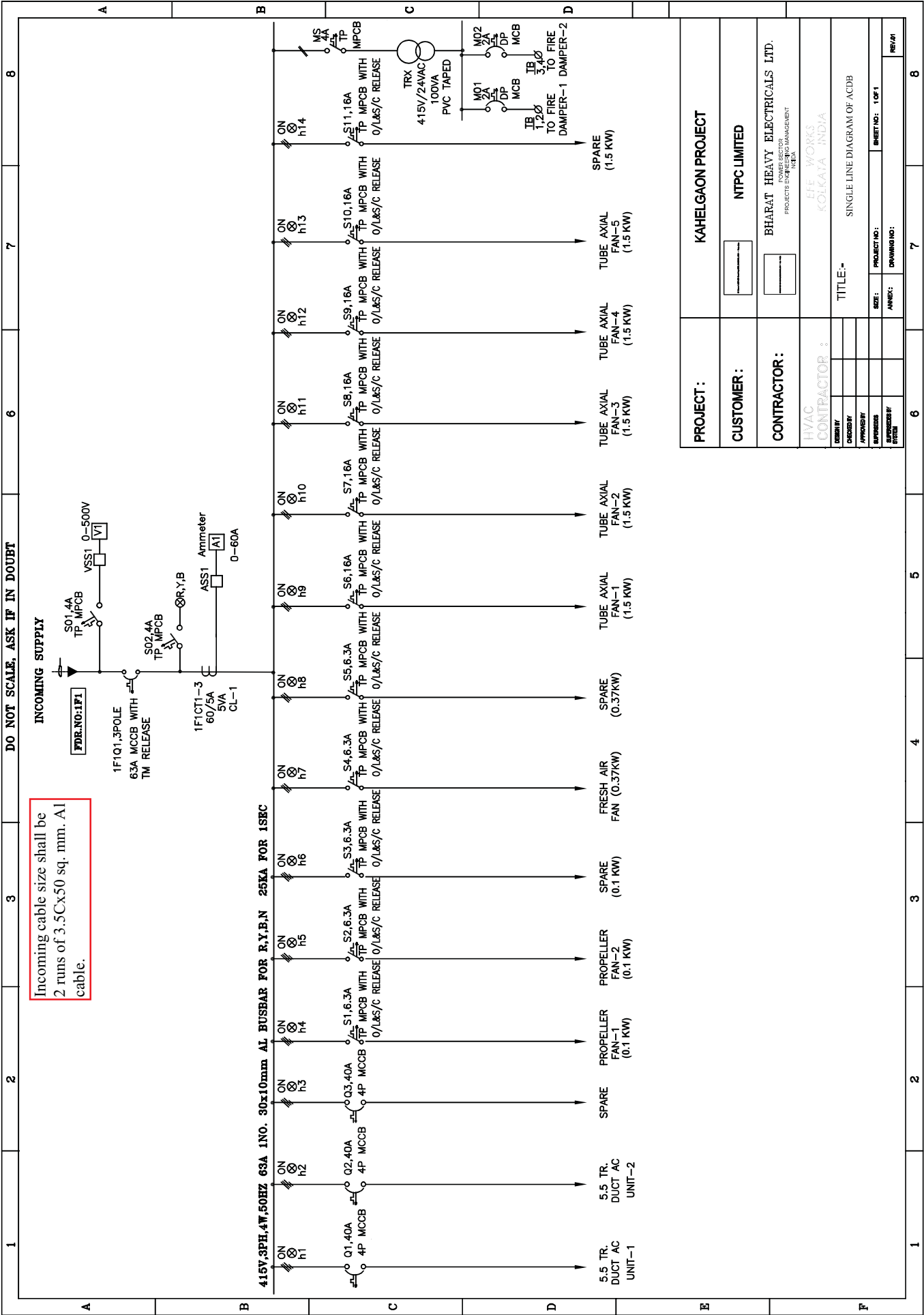

Incoming cable size shall be 2 runs of 3.5Cx50 sq. mm. Al cable.

DO NOT SCALE, ASK IF IN DOUBT

<b>PROJECT :</b>	KAHELGAON PROJECT	
<b>CUSTOMER :</b>	NTPC LIMITED	
<b>CONTRACTOR :</b>	BHARAT HEAVY ELECTRICALS LTD. PROJECTS ENGINEERING MANAGEMENT INDIA	
<b>CONTRACTOR :</b>	E.E. WORKS KOLEATA, INDIA	
<b>DESIGN BY</b>		
<b>CHECKED BY</b>		
<b>APPROVED BY</b>		
<b>DATE</b>		
<b>PROJECT NO. :</b>		
<b>DATE :</b>		
<b>REVISION :</b>		
<b>SIZE :</b>		
<b>ANNEK :</b>		
<b>PROJECT NO. :</b>		
<b>DRAWING NO. :</b>		
<b>SHEET NO. :</b>	1 OF 1	
<b>REV#1</b>		

TITLE :-  
SINGLE LINE DIAGRAM OF ACDB

1 2 3 4 5 6 7 8

D-10

SL. NO.		COMPONENT & OPERATIONS	CHARACTERISTICS	CLASS	TYPE OF CHECK	QUANTUM OF CHECK		REFERENCE DOCUMENT	ACCEPTANCE NORMS	FORMAT OF RECORD	AGENCY			REMARKS
						M	C/N				M	C	N	
ITEM : (MATERIAL, CLASS, GRADE, RATING, SIZE ETC.):			STANDARD QUALITY PLAN											
DISTRIBUTION BOARDS			Q.P. No. : 0000-999-QOE-S-034											
			REV. : 01 DTD: 15/03/04											
			PAGE 1 OF 3											
			VALID UPTO: 14.03.07											
			APPROVED BY: [Signature]											
			REVIEWED BY: S.D. SINGH, O.P. NIRANJAN, L.J. SINGH											
			APPROVED BY: VANILLEUPPA											
1	2	Distribution Boards Final Inspection and Testing	a) Overall Dimensions	MA	Meas.	100%	One Panel/Type/lot	NTPC/Main supplier Appd. Drg / data sheet	NTPC/Main supplier Appd. Drg / data sheet	Inspt Report	P	W	W	
			b) Thickness of sheet	MA	Meas.	100%	--DO--	--DO--	--DO--	--DO--	P	W	W	
			c) Paint shade	MA	Visual	100%	--DO--	--DO--	--DO--	--DO--	P	W	W	
			d) Thickness of paint	MA	Meas	100% of items	Min. 5 points/ Panel	--DO--	--DO--	--DO--	P	W	W	
			e) Surface finish	MA	Visual	100%	--D0--	Smooth, without lump	Smooth, without lump	--DO--	P	W	W	
			f) Adhesion Test	MA	Mech.	One sample/lot/size	One sample lot	Should not peel off	Should not peel off	--DO--	P	W	W	
			g) Name Plate	MA	Visual	100%	10% of each type	NTPC/Main supplier Appd drg/ data sheet	NTPC/Main supplier Appd drg/ data sheet	--DO--	P	W	W	
			h) Tightness of bus bar bolts	MA	Mech	100%	One Panel/Type/lot	Manufacturer Std.	Manufacturer Std.	--DO--	P	W	W	
			i) Bus Bar Clearance	MA	Meas.	100%	--DO--	NTPC/Main supplier Appd drg /data sheet	NTPC/Main supplier Appd drg /data sheet	--DO--	P	W	W	

LEGEND: RECORDS IDENTIFIED WITH "TICK" SHALL BE ESSENTIALLY INCLUDED BY THE CONTRACTOR IN QA DOCUMENTATION  
 \*\* M: MANUFACTURER/SUB-SUPPLIER, C: CONTRACTOR/NOMINATED INSPECTION AGENCY (SUBJECT TO PRIOR APPROVAL OF NTPC), N: NTPC, INDICATE "P" PERFORM, "W" WITNESS AND "V" VERIFICATION AS APPROPRIATE  
 "CFP" BY NTPC SHALL BE IDENTIFIED IN COLUMN "N" AS "W".  
 FORMAT - QS-01-QAI-F-10/F1-R0  
 ENGINEERING DIV./QA&I



ITEM : (MATERIAL, CLASS, GRADE, RATING, SIZE ETC.):

**DISTRIBUTION BOARDS**

**STANDARD QUALITY PLAN**

Q.P.No. : 0000-999-QQE-S-034  
 REV. : 01 DTD: 15/03/04  
 PAGE 2 OF 3  
 VALID UPTO : 14.03.07

REVIEWED BY  
 SD SINGH  
 OP.NRANJAN  
 L. J. SINGH  
 APPROVED

SL. NO.	COMPONENT & OPERATIONS	CHARACTERISTICS	CLASS	TYPE OF CHECK	QUANTUM OF CHECK		REFERENCE DOCUMENT	ACCEPTANCE NORMS	FORMAT OF RECORD	AGENCY		
					M	C/N				M	C	N
1		3	4	5	6	7	8	9	10	11		
	j) GA& Bill of material	CR	Phy.	100%	10% of each type	--DO--	--DO--	--DO--	P	W	W	
	k) Identification of Component lay out	MA	Visual	100%	One Panel/ type/lot	--DO--	--DO--	--DO--	P	W	W	
	l) Completeness of											
	i) Wiring	MA	Elect.	100%	--DO--	--DO--	--DO--	--DO--	P	W	W	
	ii) Ferruling	MA	Visual	100%	--DO--	--DO--	--DO--	--DO--	P	W	W	
	m) Size of wires	MA	Meas.	100%	--DO--	--DO--	--DO--	--DO--	P	W	W	
	n) Colour coding of bus bar	MA	Visual	100%	--DO--	--DO--	--DO--	--DO--	P	W	W	
	o) Spare terminals	MA	Meas.	100%	--DO--	--DO--	--DO--	--DO--	P	W	W	
	p) Shrouding of live parts	MA	Visual	100%	--DO--	--DO--	--DO--	--DO--	P	W	W	
	q) Door earthing	MA	Megger	100%	--DO--	--DO--	--DO--	--DO--	P	W	W	
	r) Functional Tests including HV, IR & continuity	CR	Elec.	100%	10%	--DO--	--DO--	--DO--	P	W	W	
	s) Degree of protection (Paper insertion method)	CR	Phy.	100%	One Panel/ type/lot	NTPC/Main supplier Appd drg./data sheet	NTPC/Main supplier Appd drg./data sheet	--DO--	P	W	W	

LEGEND: RECORDS IDENTIFIED WITH "TICK" SHALL BE ESSENTIALLY INCLUDED BY THE CONTRACTOR IN QA DOCUMENTATION  
 \*\*M- MANUFACTURER/SUB-SUPPLIER, C-CONTRACTOR/NOMINATED INSPECTION AGENCY (SUBJECT TO PRIOR APPROVAL OF NTPC) N- NTPC, INDICATE "P" PERFORM "W" WITNESS AND "V" VERIFICATION AS APPROPRIATE  
 "CHP" BY NTPC SHALL BE IDENTIFIED IN COLUMN "N" AS "W".  
 FORMAT -QS-01-QAI-P-10/F2-R0

CONFIDENTIAL

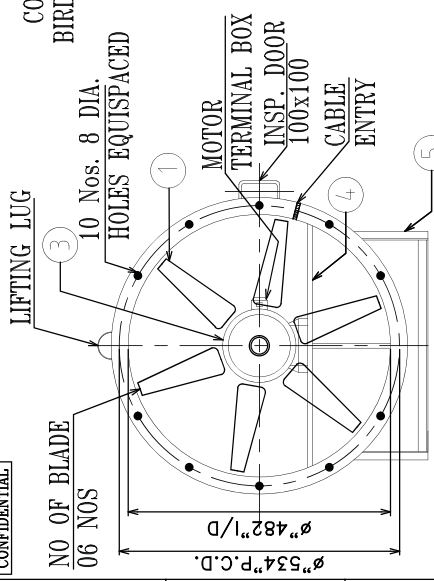

SIDE VIEW FROM X-X

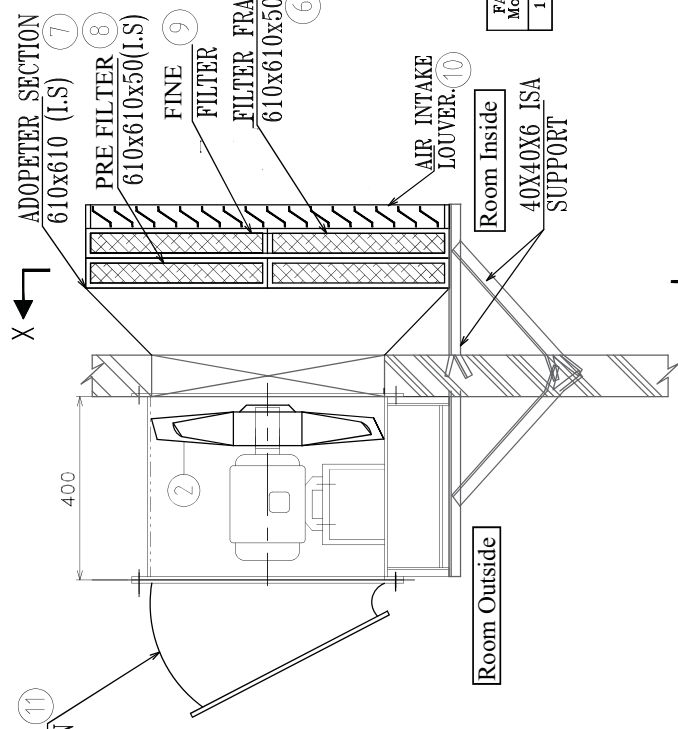

ELEVATION

--- BILL OF MATERIALS (PER UNIT) ---

SL. DESCRIPTION	DIM./TYPE/SIZE	MAT'L	QTY.	MAKE
01 FAN CASING WITH INSPECTION DOOR	3.15 mm. THK IS:1079	ALUMINIUM	1 NO.	EPF
02 IMPELLER (6 NOS BLADE)	IM6 (CAST ALUMINIUM)	ALUMINIUM	1 NO.	EPF
03 MOTOR	IS:12615-1989	STD.	1 NO.	BRI/TEL/ABR MATATHON
04 MOTOR BRACKET	4mm. THK.	MS.	1 NO.	EPF
05 FAN BRACKET	40X40X6 ISA	MS	1 SFT.	EPF
06 FILTER FRAME	610x610	G.I 22G	1 SFT.	EPF
07 ADOPETER SECTION	482 ø to 620sq G.I 22G	G.I 22G	1 SFT.	EPF
08 PRE FILTERS	610x610x50	HDFE 3 PLY	1 NOS	EPF
09 FINE FILTER	610x610x300	HDFE 6 PLY	1 NOS	EPF
10 INTAKE LOUVER	620x620x50	G.I 22G	1 NOS	EPF
11 COWL WITH BIRD SCREEN	AS PER FAN DIA	G.I 22G	1 NOS	EPF

--- MATERIAL OF CONSTRUCTION (PER UNIT) ---

CASING / THK (mm)	MS / 3.15 mm. THK (I.S - 1079 / 2062 RAL7032)
IMPELLER (MOUNTED ON MOTOR SHAFT)	CAST ALUMINIUM ALLOY
SHAFT	EN-8
TYPE OF DRIVE	DIRECT DRIVE

DIMENSIONS

FAN Model	IMPELLER DIA/mm	FAN (I/s)	FAN (p.c.d)	FAN length
19G	472	482	534	400

LOAD (K.G.)

19G	STATIC LOAD	60K.G	FAN RPM	1440
	DYNAMIC LOAD	80K.G		
	QUANTITY 04 NOS			

FANS MAKE - MATATHON

Technical Specification

SL No.	Fan inside dia (inch.)	Fan I'ype	Capacity (CMM)	Static Pressure in mm WG	Total Efficiency (%)	Velocity Pressure in mm WG	Total pressure in mm WG	BK W at 20 Deg. C.
1	19	Supply fan	800	30	60	0.090	30.090	0.109

Static Efficiency (%)	Motor Rating	Fans RPM
59.821	0.37/4	1440

NOTE:-

- ALL DIMENSIONS ARE IN MM. UNLESS OTHERWISE STATED.
- FAN WILL BE STATICALLY & DYNAMICALLY BALANCED TO GR:G6.3 AS PER ISO 1940.
- FAN CONSTRUCTION CONFORMING AS PER IS:1079. (LATEST)
- CONSTRUCTION SHALL BE AS PER IS: 12065-1987
- SUITABLE LUG SHALL BE PROVIDED FOR LIFTING OF FAN.
- MECHANICAL VIBRATION OF THE FAN & MOTOR UNIT SHALL BE RESTRICTED ACCORDING TO THE RELEVANT CLAUSES OF ISO 10816-1-1995 (B).
- PAINTING SHALL BE AS PER SPECIFICATION.
- THE TUBE AXIAL FANS SHALL BE OF VARIABLE PITCH TYPE.
- FAN MANUFACTURING AND TESTING SHALL BE AS PER IS 3588-1987
- FAN WALL CUTOUT AS PER FAN INSIDE DIAMETER BASIS.
- FAN CONSTRUCTION LIMITED AS PER ISO 14684-2003.
- MOTOR DEGREE OF PROTECTION OF IP - 55.
- MOTOR CLASS OF INSULATION - F
- MOTOR EFFICIENCY CLASS - IE-3.



TECHNICAL DATA SHEET

GRID DIFFUSER

S.No.	DESCRIPTION	DETAILS
1	MAKE	SYSTEMAIR INDIA PVT LTD
2	SIZE	NECK- AS PER APPROVED DRAWING
3	MODEL	DF(G) GRID DIFFUSER (4 WAY/3 WAY/2 WAY)
4	MATERIAL OF DIFFUSER	EXTRUDED ALUMINUM FRAME & ALUMINUM SHEET CORE
5	THICKNESS OF MATERIAL	FRAME / BORDER 2 MM THICK EXTRUDED ALUMINUM LOUVER STAMPED ALUMINIUM SHEET CORE 2 MM THICK. WITH POWER COATING (JOINT LESS) CENTER REMOVABLE CORE TYPE
6	COLOURS	RAL9003(30% GLOSSY), OTHER COLOURS ARE AVAILABLE ON REQUEST AGAINST ADDITIONAL CHARGES
7	FINISH	POWDER COATED                      EXTRUDED ALUMINUM
8	MOUNTING	DUCT COLLAR
9	WIDE	NECK 150 X 150 MM / OUTER 595 X 595 MM NECK 225 X 225 MM / OUTER 595 X 595 MM NECK 300 X 300 MM / OUTER 595 X 595 MM NECK 375 X 375 MM / OUTER 595 X 595 MM NECK 450 X 450 MM / OUTER 595 X 595 MM NECK 525 X 525 MM / OUTER 595 X 595 MM

PREPARED BY-  
DEBAJIT SARKAR

-NOTE:-

1. THE COLOUR OF POWER COATING SHALL BE AS PER THE INTERIOR DECOR.
2. SUPPLY AIR GRILLES SHALL BE AS OF DOUBLE DEFLECTION TYPE AND RETURN AIR GRILLES SHALL BE OF SINGLE DEFLECTION TYPE.
3. ALL VOLUME CONTROL (VC) DAMPER SHALL BE OPERATED BY A KEY FROM THE FRONT OF THE GRILLES / DIFFUSERS AND SHALL BE OF GI SHEET

A

OUTER

A

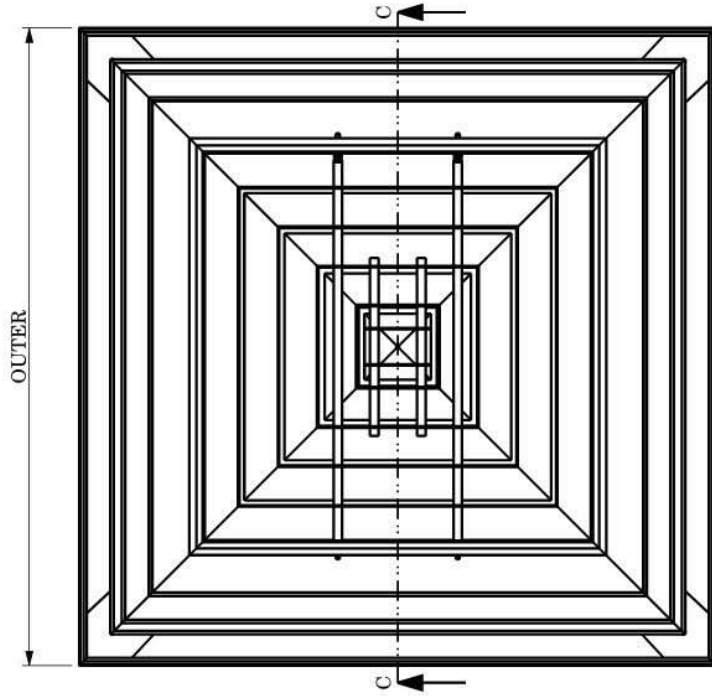
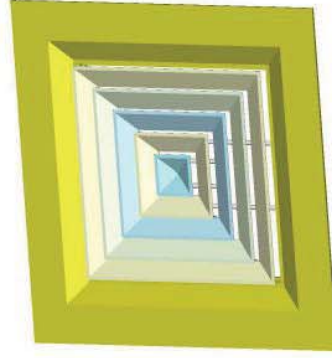

PART DESCRIPTION:

DF-G

REMOVE SHARP EDGES

DRAWING No.:  
REV NO.:

TOLERANCE LIMIT UNLESS SPECIFIED	MASS PROPERTIES:
LINEAR DIMENSIONS	WEIGHT (kg)
0.5 - 6 = ±2.0	> 120 - 400 = ±8.0
> 6 - 30 = ±4.0	> 400 - 1000 = ±12
> 30 - 120 = ±6.0	> 1000 - 2000 = ±16
Over 2000 = ±20	VOLUME (mm <sup>3</sup> )
ANGULAR DIMENSIONS	SCUR. AREA (mm <sup>2</sup> )
0 - 10 = ±8°	No. of SC/CC
> 10 - 50 = ±6°	SC
Over 400 = ±0°40'	CC

Note: This is only General arrangement drawing, the actual product supplied may deviate from the drawing.

THIS DRAWING AND DESIGN IS A PROPERTY OF SYSTEMAIR INDIA PVT. LTD. IS CONFIDENTIAL INFORMATION. SUBJECT TO THEIR RECALL. THE DOCUMENT MUST NOT BE COPIED WITHOUT THEIR WRITTEN PERMISSION. CONTRAVENTION WILL BE PROSECUTED.



**systemair**

SYSTEMAIR INDIA PVT.LTD.

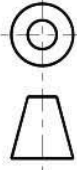

APPR. BY: *KARAPPA*

DATIP

CHKD. BY:

BMM

DATE: 09-Oct-2020

M. STANDARD:

SCALE: N.T.S.

MATERIAL:

DATE: 09-Oct-2020

SIPL/ADP/GA/3225

REVISION

REV. BY

8

7

6

5

4

3

2

1

FILE PATH: Y:\Plants\Greater Noida\CAD Team\D240BRM\DESIGN DATA\GAD\ADP\03. DIFFUSER\GRID TYPE DIFFUSER

1583 OCT 17 GAD

8

7

6

5

4

3

2

1

TECHNICAL DATA SHEET

VOLUME CONTROL DAMPER (MANUAL)

S.No.	DESCRIPTION	DETAILS
1	MAKE	SYSTEMAIR INDIA PVT.LTD.
2	SIZE	NECK- AS PER APPROVED DRAWING
3	MODEL	GI VCD
4	MATERIAL OF VCD	GALVANIZED SHEET
5	THICKNESS OF MATERIAL	FRAME-18 SWG GI SHEET
		LOUVER/BLADE- 20 SWG GI SHEET
6	TYPE OF VCD	MANUAL
7	FINISH	ZINC COATING (120 GSM)
8	MOUNTING	DUCT COLLAR
9	DEPTH	120 MM STANDARD
10	BUSH	BRONZ BUSH WITH SELF LUBRICATION
11	WIDE	MINIMUM SIZE 300 X300 mm (NECK)
		MAXIMUM SIZE 1500 X 1000 mm (NECK)
		SIZE ABOVE THAN MAX WILL BE IN PARTITION

PREPARED BY  
DEBAJIT SARKAR

-:NOTE:-

1. THE COLOUR OF POWER COATING SHALL BE AS PER THE INTERIOR DECOR.
2. SUPPLY AIR GRILLES SHALL BE AS OF DOUBLE DEFLECTION TYPE AND RETURN AIR GRILLES SHALL BE OF SINGLE DEFLECTION TYPE.
3. ALL VOLUME CONTROL (VC) DAMPER SHALL BE OPERATED BY A KEY FROM THE FRONT OF THE GRILLES / DIFFUSERS AND SHALL BE OF GI SHEET

1	2	3	4	5	6	7	8
UNLESS OTHERWISE SPECIFIED ALL DIMENSION ARE IN m.m.							
REV. NO.		DATE		REVISION		REV. BY	

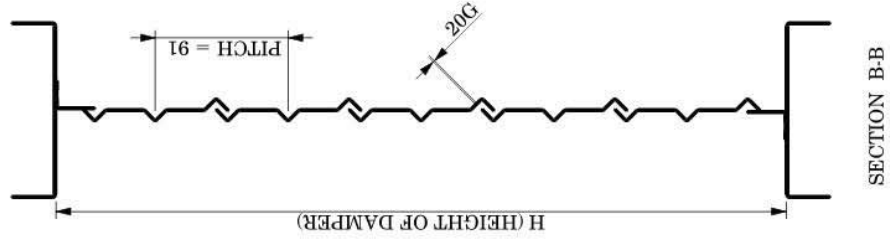
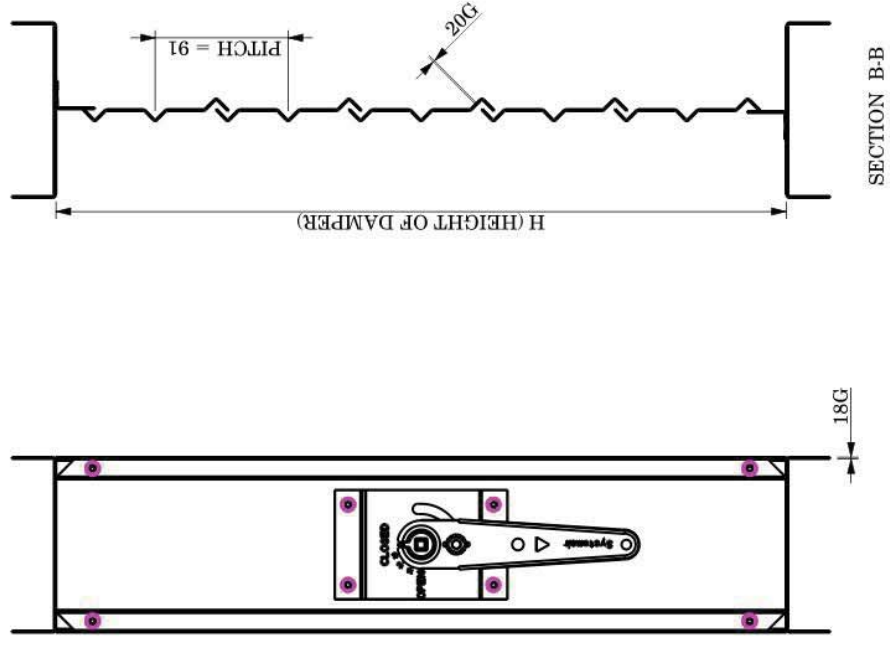
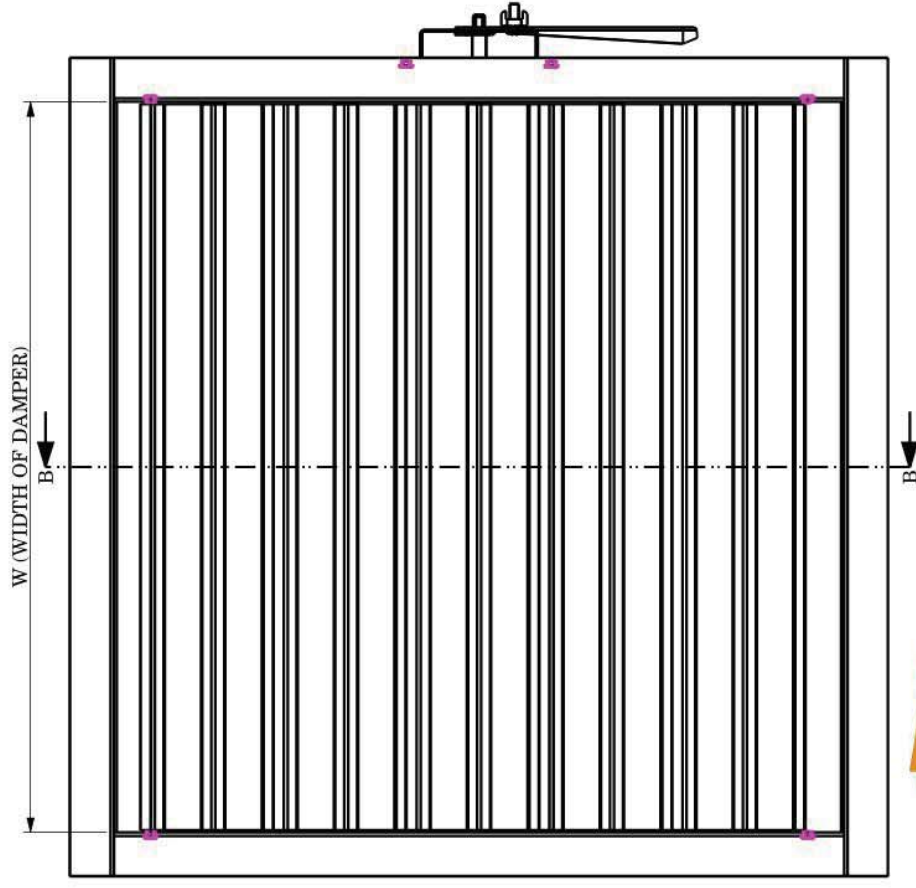

PART DESCRIPTION:		REMOVE SHARP EDGES	DRAWING No.:	REV NO.:
GI - VCD MANUAL (18G/20G)		DATE: 03-May-2016	SIPL/ADP/GA/1849	00
MATERIAL:	M. STANDARD:	SCALE:	N.T.S.	DEN. BY:
-	-	-	N.T.S.	AMIR
MASS PROPERTIES:		APPR. BY: DAITP		
VOLUME (mm <sup>3</sup> )	WEIGHT (kg)	CHKD. BY: AMIR		
-	-	DATE: 03-May-2016		
TOLERANCE LIMIT UNLESS SPECIFIED		APPROVED:		
0.5 - 6 = ±0.3	> 120 - 400 = ±2.0	SYSTEMAIR INDIA PVT.LTD.		
> 6 - 30 = ±0.5	> 400 - 1000 = ±3.0			
> 30 - 120 = ±0.8	> 1000 - 2000 = ±4.0			

THIS DRAWING AND DESIGN IS A PROPERTY OF SYSTEMAIR INDIA PVT. LTD. IS CONFIDENTIAL INFORMATION. SUBJECT TO THEIR RECALL. THE DOCUMENT MUST NOT BE COPIED WITHOUT THEIR WRITTEN PERMISSION. CONTRAVENTION WILL BE PROSECUTED.

TECHNICAL DATA SHEET

GRID DIFFUSER WITH ALUMINUM COLLAR DAMPER

S.No.	DESCRIPTION	DETAILS
1	MAKE	SYSTEMAIR INDIA PVT LTD
2	SIZE	NECK- AS PER APPROVED DRAWINGS.
3	MODEL	DF(G) + AL OBSS GRID DIFFUSER (4 WAY/3 WAY/2 WAY)
4	MATERIAL OF DIFFUSER	EXTRUDED ALUMINUM FRAME & ALUMINUM SHEET CORE
5	THICKNESS OF MATERIAL	FRAME / BORDER 2MM THICK EXTRUDED ALUMINUM LOUVER STAMPED ALUMINIUM SHEET CORE 2MM THICK. WITH POWER COATING (JOINT LESS) CENTER REMOVABLE CORE TYPE
6	COLOURS	RAL9003(30% GLOSSY), OTHER COLOURS ARE AVAILABLE ON REQUEST AGAINST ADDITIONAL CHARGES
7	FINISH	POWDER COATED
8	MOUNTING	DUCT COLLAR
9	WIDE	NECK 150 X 150 MM / OUTER 595 X 595 MM NECK 225 X 225 MM / OUTER 595 X 595 MM NECK 300 X 300 MM / OUTER 595 X 595 MM NECK 375 X 375 MM / OUTER 595 X 595 MM NECK 450 X 450 MM / OUTER 595 X 595 MM NECK 525 X 525 MM / OUTER 595 X 595 MM
10	MATERIAL OF COLLAR DAMPER	EXTRUDED ALUMINUM SHEET
11	THICKNESS OF COLLAR DAMPER	FRAME / BORDER 16 SWG THICK EXTRUDED ALUMINUM BLADE 1 MM THICK ALUMINUM
12	FINISH OF DAMPER	BLACK POWDER COATED
13	TYPE OF OBSS	KEY OPERATED OPPOSED BLADE TYPE
14	MOUNTING	DUCT COLLAR
15	WIDE	MINIMUM SIZE 150 X 150 MM (NECK) MAXIMUM SIZE 525 X 525 MM (NECK) OR AS PER DIFFUSER NECK SIZE

PREPARED BY-  
DEBAJIT SARKAR

-:NOTE:-

1. THE COLOUR OF POWER COATING SHALL BE AS PER THE INTERIOR DECOR.
2. SUPPLY AIR GRILLES SHALL BE AS OF DOUBLE DEFLECTION TYPE AND RETURN AIR GRILLES SHALL BE OF SINGLE DEFLECTION TYPE.
3. ALL VOLUME CONTROL (VC) DAMPER SHALL BE OPERATED BY A KEY FROM THE FRONT OF THE GRILLES / DIFFUSERS AND SHALL BE OF GI SHEET

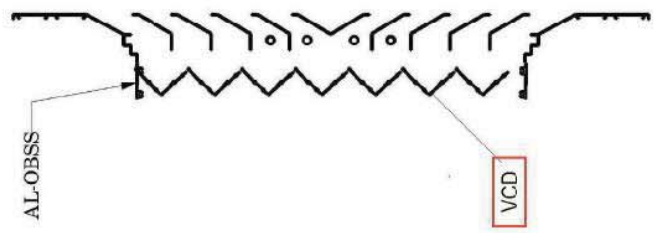
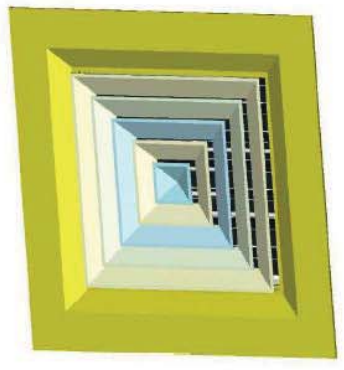
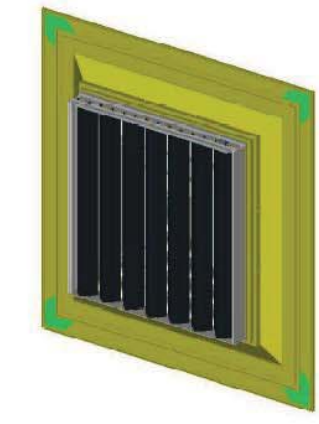

SECTION A-A

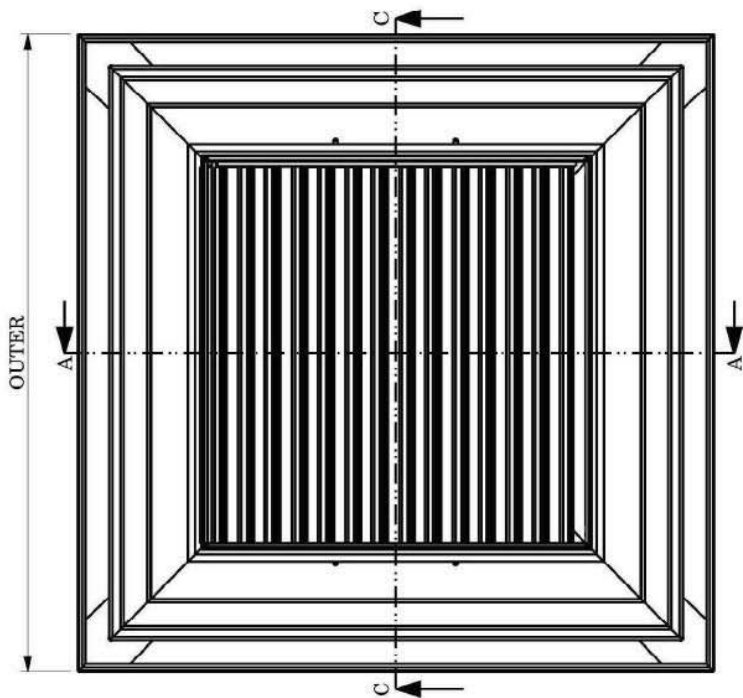

SECTION C-C

FOR SUPPLY

S.NO	DIFFUSER SIZE	NECK SIZE	OUTER
1	150	150 x 150	595 x 595
2	225	225 x 225	595 x 595
3	300	300 x 300	595 x 595
4	375	375 x 375	595 x 595
5	450	450 x 450	595 x 595

PART DESCRIPTION:		REMOVE SHARP EDGES	DRAWING No.:	REV NO.:
DF (G) + AL OBSS			SIPL/ADP/GA/2427	00
MATERIAL:	M. STANDARD:	SCALE:	CHKD. BY:	APPD. BY:
		N.T.S.	BRM	KARADMAN
<p>systemair</p> <p>SYSTEMAIR INDIA PVT.LTD.</p>				

TOLERANCE LIMIT UNLESS SPECIFIED	MASS PROPERTIES:
LINEAR DIMENSIONS	WEIGHT (kg)
0.5 - 6 = ±2.0	> 120 - 400 = ±8.0
> 6 - 30 = ±4.0	> 400 - 1000 = ±12
> 30 - 120 = ±6.0	> 1000 - 2000 = ±16
Over 2000 = ±20	SCR. AREA (mm <sup>2</sup> )
ANGULAR DIMENSIONS	No. of SC/CC
0 - 10 = ±8°	> 50 - 120 = ±4°
> 10 - 50 = ±6°	> 120 - 400 = ±2°
Over 400 = ±0°40'	

THIS DRAWING AND DESIGN IS A PROPERTY OF SYSTEMAIR INDIA PVT. LTD. IS CONFIDENTIAL INFORMATION. SUBJECT TO THEIR RECALL. THE DOCUMENT MUST NOT BE COPIED WITHOUT THEIR WRITTEN PERMISSION. CONTRAVENTION WILL BE PROSECUTED.



**DATA SHEET : TWIGA INSUL TI-1500(24 Kg./m3)**

<b>Parameter</b>	<b>Technical Specification (Duct Thermal insulation)</b>
Make	U.P Twiga Fiberglass Ltd.
Material	Resin bonded fiberglass wool Roll
Standard/Codes to follow	IS 8183: 93/IS 3144: 90
Product Code	1500/50 Plain Roll Form
Physical form	Standard Roll size, width x length: 1.2m x 15m x 50 mm ( TI 1500/50 Plain) = 18 M2
Nominal bulk density	24 Kg/m <sup>3</sup>
Thickness	50mm
Thermal conductivity	0.0393 W/MK at 50 ° C mean temp. (As per GTL Report Feb 2021)

**General Glass wool Properties:**

<b>Parameter</b>	<b>Conformance</b>
<b>Fire Properties</b>	
Non combustibility	Non combustible as per BS 476 part 4
Ignitibility	Class P(Not easily ignitable material) as per BS 476 part 5
Surface Spread of flame	NIL. Class 1 as per BS 476 part 7
Fire propagation	Class 'O', [index I<12, sub-index i1<6].Conforms to BS 476 part 6 and 7.
Toxicity	Non toxic as per BS 6853
Moisture content	<2% .conforms to IS 3144/IS 8183
Shot content	Nil.<2%). conforms to IS 3144/IS8183
Sulphar /Chloride content	Nil. Conforms to IS 3144/IS 8183
Mould growth	Conforms to IS 3144/IS 8183. Inorganic glass fiber does not support mould growth.
Chemical	Neither acidic no basic, chemically almost neutral. pH value very close to 7.



**DATA SHEET : TWIGA INSUL TI-3000 (48 Kg/m<sup>3</sup>)**

<b>Parameter</b>	<b>Technical Specification (Duct Acoustic insulation)</b>
Make	U.P Twiga Fiberglass Ltd.
Material	Resin bonded fiberglass wool Rigidboard
Standard/Codes to follow	IS 8183: 93 /IS 3144: 90
Product Code	TI-3000/25
Physical form	Rigid Board in LDPE Packing Standard size, <b>width x length x thickness:</b> 1.2 m x 0.6m x 25 mm = 18.72 M2/ Packet (26 Boards in one packet)
Nominal bulk density	TI-3000 (48 Kg/m <sup>3</sup> )
Thickness	25 MM
Thermal conductivity	0.0336 W/m.k at 50 degree C mean temperature as per GTL report dated Feb-2021)

**General Glass wool Properties:**

<b>Parameter</b>	<b>Conformance</b>
Fire Properties	
Non combustibility	Non combustible as per BS 476 part 4
Ignitibility	Class P(Not easily ignitable material) as per BS 476 part 5
Surface Spread of flame	NIL. Class 1 as per BS 476 part 7
Fire propagation	Class 'O', [index I<12, sub-index i1<6].Conforms to BS 476 part 6 and 7.
Toxicity	Non toxic as per BS 6853
Moisture content	<2% .conforms to IS 3144/IS 8183
Shot content	Nil.<2%). conforms to IS 3144/IS8183
Sulphar /Chloride content	Nil. Conforms to IS 3144/IS 8183
Mould growth	Conforms to IS 3144/IS 8183. Inorganic glass fiber does not support mould growth.
Chemical	Neither acidic no basic, chemically almost neutral. pH value very close to 7.

**PROJECT : 4X210 MW KAHALGAON ESP-R&M**

**Main Customer - National Thermal Power Corporation Limited**

**Main Contractor - Bharat Heavy Electrical Ltd. ,Power Sector, PEM, Noida**

**Sub Contractor - EFE Works**

**SUB: Data Sheet of Pipes**

<b>Sl. No.</b>	<b>DESCRIPTION</b>	<b>SPECIFICATION</b>	<b>Remarks</b>
1	Refrigerant Pipe	Seamless steel tubes conforming heavy grade IS:1239 or Copper tubes as per IS:191 hard copper grade  Suction Pipe = 19mm (OD) thickness 1.1 mm Discharge Pipe = 15.8 mm (OD) thickness 1.1 mm	Same has been already approved in Ramagundam 3X200 MW ESP R&M. Doc. No. 3120-104A-01-PVM-107
2.	Drain Pipe 40 NB	GI conforming heavy grade as per IS 4736 Screw end Make - JINDAL/TATA	Same has been already approved in Ramagundam 3X200 MW ESP R&M. Doc. No. 3120-104A-01-PVM-107

## GI Sheet for Ducting of Split Ductable Split AC in ESP Control Rooms

<b><u>Technical Specification of G.I Sheet</u></b>	
<b><u>Sl.</u></b>	<b><u>Description</u></b>
1	<b><u>Application</u></b> Low pressure air ducting
2	<b><u>Make</u></b> Tata Steel / Tisco / Bhushan/ Jindal/ Jsw steel
3	<b><u>Type</u></b> G.I sheet lock forming quality (LFQ)
4	<b><u>Grade</u></b> conforming to class 275 of IS: 277
5	<b><u>Form Factors</u></b> Conforming to class 655
6	<b><u>Coating</u></b> 275 GSM
7	<b><u>Shape</u></b> Rectangular
8	<b><u>Flange Type</u></b> TDF / TDC, As Applicable.
9	Thickness
	0 to 750 mm - = 0.63mm as per specification Clause 4.04.02, Sub-Section-I-M3, Part-B
	751 to 1500 mm - = 0.80mm
	1501 to 2200 mm - = 1.00 mm
	2200 mm to Above - = 1.25 mm as per specification Clause 4.04.02, Sub-Section-I-M3, Part-B