

1100883/2022/PS-PEM-EL



**TECHNICAL SPECIFICATION FOR
LIGHTING FIXTURES, LAMPS AND
MISCELLANEOUS ITEMS**

SPECIFICATION NO. PE-SS-999-558-E006

VOLUME II

SECTION II

REVISION: 0

DATE: 08.09.2016

SECTION – II

STANDARD TECHNICAL REQUIREMENTS

1100883/2022/PS-PEM-EI

**TECHNICAL SPECIFICATION FOR
LIGHTING FIXTURES, LAMPS &
MISCELLANEOUS ITEMS**

SPECIFICATION NO. PE-SS-999-558-E006

VOLUME II

SECTION II

REVISION: 0

DATE: 08.09.2016

SHEET 1 OF 38

**TECHNICAL SPECIFICATION FOR
LIGHTING FIXTURES, LAMPS & MISCELLANEOUS ITEMS**



**TECHNICAL SPECIFICATION FOR
LIGHTING FIXTURES, LAMPS &
MISCELLANEOUS ITEMS**

SPECIFICATION NO. PE-SS-999-558-E006

VOLUME II

SECTION II

REVISION: 0

DATE: 08.09.2016

SHEET 2 OF 38

CONTENTS

<u>CLAUSE</u>	<u>DESCRIPTION</u>
1.0	INTENT OF SPECIFICATION
2.0	CODES & STANDARDS
3.0	LIGHTING SYSTEM DESCRIPTION (CONCEPTUAL VIEW)
4.0	SYSTEM DESIGN ENGINEERING
4.1	ENGINEERING INPUTS
4.2	DESIGN CRITERIA
4.3	ENGINEERING OUTPUTS
5.0	LUMINAIRES, ACCESSORIES AND LAMPS
5.1	GENERAL REQUIREMENTS OF LUMINAIRES
5.2	LUMINAIRE & OTHER ITEMS
5.3	CONTROLGEAR BOX (NON-INTEGRAL TYPE)
5.4	REFLECTORS
5.5	LAMP HOLDERS
5.6	STARTER HOLDERS
5.7	BALLASTS
5.8	STARTERS
5.9	CAPACITORS
5.10	LAMPS
5.11	JUNCTION BOXES
5.12	RECEPTACLES
5.13	CEILING FANS & REGULATORS
5.14	LIGHTING CONTROL SWITCHBOXES
5.15	CABLE GLANDS
5.16	CABLE LUGS
5.17	FLEXIBLE METALLIC CONDUITS AND FITTINGS
5.18	PVC CONDUITS
6.0	SURFACE TREATMENT
7.0	PACKING
8.0	GUARANTEED PERFORMANCE REQUIREMENTS
9.0	INSPECTION & TESTING
10.0	SPARES
11.0	TOOLS & TACKLES
12.0	DOCUMENTATION
	ANNEXURE-I: LUMINAIRE DETAILS



**TECHNICAL SPECIFICATION FOR
LIGHTING FIXTURES, LAMPS &
MISCELLANEOUS ITEMS**

SPECIFICATION NO. PE-SS-999-558-E006

VOLUME II

SECTION II

REVISION: 0

DATE: 08.09.2016

SHEET 3 OF 38

1.0 INTENT OF SPECIFICATION

- 1.1 The requirements given in specification for supply of equipment and system design engineering shall be fully complied with.
- 1.2 For the equipment of supply in vendor's scope, the "design" shall broadly cover the selection of components, materials, sizes etc. and complete responsibility of establishing the correctness of equipment design rests with the vendor.
- 1.3 It is not the intent to specify herein all the details of design and manufacture. However, the equipment shall conform in all respects to high standards of design, engineering and workmanship, and shall be capable of performing required function in a manner acceptable to Purchaser, who will interpret the meaning of drawings and specifications and shall be entitled to reject any work or material, which in his judgement is not in full accordance herewith.
- 1.4 Make of all equipment and components shall be to the approval of Purchaser. Bidder to comply to Sub-vendor list enclosed as Annexure to Section I, however same shall be subjected to end client approval without any commercial implication.

2.0 CODES & STANDARDS

- 2.1 The material shall comply with all currently applicable safety codes and statutory regulations of India as well as of the locality where the material is to be installed.
- 2.2 The material, construction, manufacture, inspection and testing shall conform to the latest revisions of standards as specified in Data Sheet-A.
- 2.3 In case of conflict between the applicable reference standard and this specification, stringent requirement shall govern.

3.0 LIGHTING SYSTEM DESCRIPTION (CONCEPTUAL VIEW)

- 3.1 All areas of plant (indoor and outdoor) shall be provided with suitable lighting arrangement to meet the functional requirements by use of various types of luminaires so as to achieve the desired quality and level of illumination.
- 3.2 Lighting system shall also cover the low voltage power services such as power receptacles and single phase feeders.
- 3.3 Lighting system shall be fed through various power sources such as AC Normal, AC Emergency and DC Emergency supply to achieve the desired reliability.
- 3.4 Power tapped from various sources shall be distributed through lighting distribution boards and lighting panels upto the various luminaires and power outlet sockets / feeders.



**TECHNICAL SPECIFICATION FOR
LIGHTING FIXTURES, LAMPS &
MISCELLANEOUS ITEMS**

SPECIFICATION NO. PE-SS-999-558-E006

VOLUME II

SECTION II

REVISION: 0

DATE: 08.09.2016

SHEET 4 OF 38

4.0 SYSTEM DESIGN ENGINEERING

Engineering shall be done by the vendor only during the contract engineering stage as the same is covered in his scope. During tender stage, bidder shall make his quotation on the basis of BOQ furnished by the purchaser with the tender document.

- 4.1 ENGINEERING INPUTS** : Complete engineering shall be done by the vendor on the basis of documents listed below. The engineering inputs shall be furnished by purchaser. However, furnishing of these inputs shall not absolve the vendor of responsibility to visit site and get acquainted with actual site conditions.

4.1.1 Indoor Areas

- a) Room dimensions (details as covered in various layout drawings)
- b) Lighting System Design Data (LSDD) covering typical values for various types of indoor areas, indicating :
 - i. Required average illumination level
 - ii. Reflection factors for walls, ceiling and floor
 - iii. Maintenance factor
 - iv. Type of luminaire
 - v. Mounting height of luminaire
 - vi. Height of working plane
- c) AC Emergency lighting requirements
- d) DC lighting requirements
- e) Requirement of sockets
- f) Requirement of exhaust fans and fan points

4.1.2 Outdoor Areas

- a) Area geometry (details as covered in various layout drawings)
- b) Lighting System Design Data (LSDD) covering typical values for various types of outdoor areas, indicating:
 - i. Average illumination level
 - ii. Type of luminaire
 - iii. Pole heights / mounting height
 - iv. AC Emergency lighting requirement



**TECHNICAL SPECIFICATION FOR
LIGHTING FIXTURES, LAMPS &
MISCELLANEOUS ITEMS**

SPECIFICATION NO. PE-SS-999-558-E006

VOLUME II

SECTION II

REVISION: 0

DATE: 08.09.2016

SHEET 5 OF 38

- v. DC lighting requirements
- vi. Maintenance factor
- c) Requirement of sockets

4.1.3 Other inputs

- a) Plot plan, Main equipment plan and TG hall floor plans (to assess quantum of area lighting drawings)
- b) Suggestive location of LDBs
- c) Suggestive power distribution scheme (SLDs)
- d) Control schemes
- e) Single phase feeder details
- f) No. of sockets / criteria for computation of no. of sockets / location of sockets etc.
- g) LDB/WDB details
- h) LP details
- i) Poles & Masts details
- j) Conduit sizes
- k) Wire sizes
- l) Earthing material sizes

4.2 DESIGN CRITERIA:

4.2.1 General Requirements of Design

- a) Lighting system shall be provided to ensure adequate visual performance, safety and reliability and shall be free from excessive glare and flicker from discharge lamps. Particular attention shall be paid to ensure that level of illumination is satisfactory in all respects including viewing of all instruments, alarms, annunciators and indicating lamps.
- b) Complete system design shall be done on the basis of inputs provided by the purchaser and in line with the laid down criteria.
- c) Requirements of sockets shall be as per the criteria / number of sockets given by the purchaser during detailed engineering stage.
- d) Complete power distribution system shall be designed keeping following criteria in view :



TECHNICAL SPECIFICATION FOR LIGHTING FIXTURES, LAMPS & MISCELLANEOUS ITEMS

SPECIFICATION NO. PE-SS-999-558-E006

VOLUME II

SECTION II

REVISION: 0

DATE: 08.09.2016

SHEET 6 OF 38

- Simplicity
- Controlled voltage drop
- Cost effectiveness

4.2.2 Sources of Power Supply

- a) The illumination of various indoor and outdoor areas in the main plant and off site areas shall comprise of one or more of the following systems:
 - Normal AC Lighting System
 - Emergency AC Lighting System
 - DC Lighting System
- b) Arrangement and distribution of power shall depend upon the functional requirements of areas and therefore supply from all types of power sources shall not be made available to all areas. Lighting & LV power services in different areas shall be provided as per Annexure-B enclosed.
- c) 24V AC lighting for maintenance purposes (for hand lamps and/or hand operated tools) shall be supplied from 240/24V fixed/ portable lighting module.

4.2.3 Lighting philosophy

a) Normal AC Lighting System

Normal AC lighting system 415V, 3 phase, 4 wire, will be fed from lighting panels (LPs) which in turn will be fed from the lighting distribution boards (LDBs). Street lights/ flood lights shall be fed from Street Lighting Panel (SLP), Welding receptacles shall be fed from Welding DB/ MCC in offsite areas.

b) Emergency AC Lighting System

This system shall be provided for certain important areas in the main plant. The lighting fixtures connected to this system shall be normally "ON" along with the normal AC system. These will be fed from emergency lighting panels (ELPs) which in turn will be fed from 3-phase, 4-wire supply from the emergency lighting distribution boards (ELDB'S). These lights will go off for a few seconds in case of AC supply failure at Emergency Switchgear, but shall be automatically restored when Emergency Switchgear is energized by Diesel generator set.

c) DC Lighting System

At strategic locations in the main plant, a few lighting fixtures fed from 220V DC supply, shall be provided to enable safe movement of operating personnel and access to important control points during an emergency, when both the normal AC and Emergency Lighting system fail. These lighting fixtures will be fed from 220V DC LPs which in turn will be fed from DC LDBs.

The supply to the DC lighting panels shall be automatically switched ON in case of loss of AC supply at station service switchgear as well as Emergency switchgear. The DC supply will be automatically switched OFF after about 3 minutes



**TECHNICAL SPECIFICATION FOR
LIGHTING FIXTURES, LAMPS &
MISCELLANEOUS ITEMS**

SPECIFICATION NO. PE-SS-999-558-E006

VOLUME II

SECTION II

REVISION: 0

DATE: 08.09.2016

SHEET 7 OF 38

following the restoration of supply to normal AC or emergency AC lighting system.

In auxiliary /off site buildings, emergency DC lighting is to be provided through self contained DC emergency fixture at strategic locations. The fixtures shall be switched 'ON' automatically in case of failure of AC supply.

d) Street Lighting/ Flood Lighting

Street lights / flood lights will be fed from Street Lighting Panel (SLP). The number of street lights / flood lights shall be grouped in such a way that they will be fed from the nearest SLP available. Street lights shall have provision of automatic switching ON and OFF in any one of the following modes and as per the purchaser's scheme:

- i. Manual
- ii. Automatic through 00 - 24 hrs time switch
- iii. Automatic through combination of 00 - 24 hrs time switch and a remote sensing device for monitoring external illumination level. Each SLP shall be provided with a time switch and a remote light sensing device.

4.2.4 Number of Luminaires

- a) All calculations shall be done as per the input data covered under "Engineering Inputs".
- b) Total AC luminaires

Total number of AC luminaires for indoor and outdoor areas shall be calculated on the basis of point to point method by an established computer program. Optimisation criteria shall form part of street lighting calculations.

For AC emergency lighting, a specified percentage of total AC luminaires shall be considered as AC emergency luminaires. The percentage shall be informed during detail engineering.

4.2.5 Layout Considerations

a) General Layout Considerations

- i. Layout of equipment such as LDBs and LPs shall be on the basis of following criteria :
 - Ease of operation
 - Maintainability
 - Aesthetics
- ii. Luminaires shall be located to meet the functional requirements of the area. Aesthetics shall form part of layout considerations.
- iii. Due considerations shall be given to the mounting arrangement depending upon location and type of area.
- iv. While preparing lighting system layout drawings for air conditioned control rooms/areas having false ceilings, the vendor shall be required to interface



**TECHNICAL SPECIFICATION FOR
LIGHTING FIXTURES, LAMPS &
MISCELLANEOUS ITEMS**

SPECIFICATION NO. PE-SS-999-558-E006

VOLUME II

SECTION II

REVISION: 0

DATE: 08.09.2016

SHEET 8 OF 38

with the Air Conditioning / Ventilation Duct layout and false ceiling layout drawings to avoid fouling / interference.

- v. The poles shall be located 1.5m away from the road edge. The buried cable shall run in hume pipe / duct bank wherever it is crossing the roads.
- vi. 240V AC, 5/15A universal socket (at least two number) shall be provided in office, store, cabin etc. The receptacles shall be provided at interval of 20m or part thereof for hand tools etc. One no. 20A, 240V AC industrial type receptacle shall be provided at suitable location in all other area as required. The receptacles shall be controlled through switch/MCBs. In hazardous area, receptacles shall be flame proof.
- vii. Suitable nos. of 63A/125A, 3 phase, 415V industrial receptacle with switch shall be provided at specific points in power plant area for welding purposes. At least one 63A/125A receptacle shall be provided in each off-site building.
- viii. 1200mm/ 1400mm sweep ceiling fans with stepped electronic regulator shall be provided for office room, store rooms and social buildings which are not covered by air-conditioned and ventilation system.
- ix. All fans including pedestal fans shall comply to relevant IS.

b) Conduit System

- i. Unless indicated otherwise, conduits shall originate from respective lighting panels and shall continue upto the luminaires for all indoor areas.
- ii. Conduits shall run in straight runs, parallel to building columns, walls etc. as far as practicable.
- iii. Unnecessary bends and crossings shall be avoided.
- iv. In the corrosive environment, conduit installations shall be made with corrosion proof conduits. Such requirements shall be clearly indicated while preparing BOQ.
- v. Conduits in control room and other air-conditioned areas shall be surface mounted on the roof above false ceiling. However vertical drops of conduits shall be through column flanges or grooved to the wall, finally covered for better aesthetics.

c) Wiring

- i. Each circuit from LP shall be taken in a separate conduit.
- ii. Wiring of AC normal, AC emergency & DC emergency lighting system shall be carried out in separate conduits.



**TECHNICAL SPECIFICATION FOR
LIGHTING FIXTURES, LAMPS &
MISCELLANEOUS ITEMS**

SPECIFICATION NO. PE-SS-999-558-E006

VOLUME II

SECTION II

REVISION: 0

DATE: 08.09.2016

SHEET 9 OF 38

- iii. Receptacle wiring shall be distinct from lighting conduits. No two phase circuits shall be run in the same conduit. However different circuits of same phase may be laid in the same conduit.
- iv. Maximum three nos. of receptacles shall be loop-in & loop-out in a circuit.
- v. Filling area of wires in conduit shall not exceed 40% of the conduit area.
- vi. Wiring shall be done with following conductor sizes:
 - Luminaires – 2.5 sq. mm
 - 5A plug & socket – 2.5 sq. mm
 - 5/15A and 20A plug & socket – 4 sq.mm
- vii. Wiring shall be designed for the uniformly distributed spread of luminaires on each phase i.e. R,Y,B. Distribution of luminaires on these phases shall be such so that there is generally uniform light intensity in the event of failure of one or two phases.
- viii. Luminaires located in offices, stores, laboratories, toilets etc. shall be individually or group controlled.

d) Cabling

- i. Cables shall be considered wherever it is not desirable to run the insulated wires due to long runs or for any other valid reason.
- ii. Cable Schedule shall be prepared for all cable connections.

4.3 ENGINEERING OUTPUTS:

Vendor shall prepare and submit following documents and drawings for purchaser's approval :

- a) Lighting calculations for indoor areas covering details such as room dimensions (length, width, height), illumination level, reflection factors (walls, ceiling, floor), maintenance factor, type of luminaire, mounting height of luminaire, room index, coefficient of utilisation, no. of luminaires (AC Normal & AC Emergency), lumen output of each luminaire, reference drawings and remarks.
- b) Lighting calculations for outdoor areas covering average illumination level, type of luminaire, chart for illumination level at various points in the area; location (coordinates), number and height of poles; type, number (normal + emergency) and orientation of luminaires etc. Calculated values of average and minimum illumination level as obtained through computer package shall also be furnished. Dot density plots for lux level shall be furnished if available in the computer package.
- c) Single line diagrams of power distribution upto Lighting Panels. Separate drawing for complete lighting distribution shall also be prepared by vendor.



**TECHNICAL SPECIFICATION FOR
LIGHTING FIXTURES, LAMPS &
MISCELLANEOUS ITEMS**

SPECIFICATION NO. PE-SS-999-558-E006

VOLUME II

SECTION II

REVISION: 0

DATE: 08.09.2016

SHEET 10 OF 38

- d) Loads on each phase of LP and LDB with consideration of diversity factor for sockets.
- e) Layout drawings for each indoor area indicating location of luminaires, sockets, fan points, exhaust fans, LDBs and LPs. Details of type of luminaires, source of power supply (AC Normal, AC Emergency, DC Normal and DC Emergency). Bill of Material shall also be covered which shall include unit wise requirements of luminaires and other items.
- f) Layout drawings for each outdoor area indicating location of poles / towers, orientation of luminaires, sockets and LPs. Details of pole height / mounting height, type of luminaires, source of power supply (AC Normal, AC Emergency, DC Emergency). Bill of Material shall also be covered for various types of luminaires.
- g) Conduit layout drawings with wiring and load distribution details as superimposed on the area layout drawings indicated above. Drawings shall include Bill of Material for conduits, wires etc.
- h) Wiring and load distribution details for outdoor areas.
- i) Master Bill of Material (to be submitted at regular intervals of engineering progress) including all items required for the complete lighting system viz. lighting fixtures, lamps, Lighting DBs, Welding DBs, lighting panels, conduits, PVC wires etc.
- j) In case of revised inputs or site feedback, preparation and submission of revised engineering outputs shall also be in the scope of vendor.
- k) Calculation for selection of number and size of containers
- l) Packing procedures and drawings.

5.0 LUMINAIRES, ACCESSORIES AND LAMPS

5.1 GENERAL REQUIREMENTS OF LUMINAIRES

- a) All luminaires and accessories shall be designed for continuous operation and shall be suitable for the system design data given in Data Sheet A.
- b) Luminaires shall be complete with accessories mounted inside the luminaire assembly. Lamps shall be supplied separately as per BOQ.
- c) All luminaires and accessories shall be suitable for operation in the atmospheric conditions prevailing at site.
- d) Power factor for fluorescent lamp luminaires shall be 0.9 or more and that for HPMV/ HPSV luminaires shall be 0.85 or more. Power factor correction capacitors shall be provided for this purpose.



**TECHNICAL SPECIFICATION FOR
LIGHTING FIXTURES, LAMPS &
MISCELLANEOUS ITEMS**

SPECIFICATION NO. PE-SS-999-558-E006

VOLUME II

SECTION II

REVISION: 0

DATE: 08.09.2016

SHEET 11 OF 38

- e) Luminaires shall be designed for minimum glare. No bright spots should appear from the lamp or from the reflectors.
- f) All accessories shall be wired upto a terminal block or a separate weather proof metallic terminal box suitable for 2.5 sq. mm. copper wire termination.
- g) All internal wiring shall be of PVC or silicon rubber insulation, capable of withstanding the maximum temperature to which it will be subjected under specified service conditions without deterioration.
- h) All luminaires and accessories including the breathing holes shall be vermin proof.
- i) Surface Treatment:
 - All surfaces after manufacture shall be thoroughly cleaned and degreased. Pre-treatment of surfaces shall be as per the applicable standard. Pretreated surfaces shall be free from rust, sharp edges, scales and burrs.
 - Finish of surfaces shall be non-porous, smooth and unfaded.
- j) All metal parts of the luminaires shall be bonded and connected to the earthing terminal. Earthing terminal shall be suitable for connecting 14 SWG GI wire.
- k) Flood lights shall be provided with base frame / base plate for mounting on structural steel members / wall.
- l) All weather proof luminaires shall have the control gear housed in a weather proof enclosure with necessary gaskets, mounting bracket, locking screws etc.

5.2 LUMINAIRE TYPES & OTHER ITEMS

5.2.1 General requirements depending upon type of luminaire are listed below. Specific requirements of each luminaire are indicated in "Luminaire Details" enclosed as Annexure-I.

a) Channel Mounted Luminaires (Fluorescent Luminaires)

- Channel mounted luminaires, except the special purpose luminaires, shall have CRCA sheet steel base plate / rail / channel / box / side panels / housing as per "Luminaire Details". Sheet shall be completely stove enameled unless mentioned vitreous enameled in "Luminaire Details". Colour of enamel shall be grey on all non-reflecting surfaces and white on reflecting surfaces.
- Twin fluorescent luminaires shall be wired in lead-lag circuit to minimise stroboscopic effect.
- Luminaires suitable for surface mounting shall also be suitable for pendant mounting. Knockouts of 20mm ET conduit fixation shall be provided for this purpose.



**TECHNICAL SPECIFICATION FOR
LIGHTING FIXTURES, LAMPS &
MISCELLANEOUS ITEMS**

SPECIFICATION NO. PE-SS-999-558-E006

VOLUME II

SECTION II

REVISION: 0

DATE: 08.09.2016

SHEET 12 OF 38

b) Decorative Fluorescent Luminaires

- Decorative luminaires shall be provided with one of the following as per “Luminaire Details” :
 - i. Perspex acrylic diffuser.
 - ii. High purity, anodised aluminium, mirror optic reflectors with anodised aluminium matt finish transverse fins to control glare.
 - iii. Opal polystyrene louvers and sheet steel side panels.
 - iv. Vertical metallic louvers finished in stove enamelled white and with sheet steel side panels.
- End plates of decorative luminaires shall be of high impact polystyrene or sheet metal finished in black colour.
- Diffusers and louvers for the fluorescent lamps shall be made of high impact polystyrene sheet and shall have no yellowing property over a prolonged period of use.
- Recessed type decorative luminaires shall be suitable for mounting with gypsum boards / luxalon / plaster of Paris/aluminium frame false ceiling of standard size as per Data Sheet A and “Luminaire details”.

c) Industrial Fluorescent Luminaires (General Purpose)

- Additional reflectors, wherever provided, shall be easily removable type.

d) Industrial Fluorescent Luminaires (Special Purpose)

- Luminaires for chemical vapour (acidic / alkaline) laden environment shall be of cast aluminium controlgear box and end boxes. Controlgear housing shall have detachable, one piece neoprene gasket cover to make it weather proof. Design shall be suitable for chemically charged environment.
- Luminaires for corrosive and dust laden environment shall be made of tray type sheet steel housing and transparent acrylic visor supported by a galvanised sheet steel frame, fitted to the housing with gasket all around. Cable entry shall be from the side of luminaire. Luminaire shall be totally dust and vapour proof.
- Luminaires for highly corrosive environment shall have with sheet aluminium/ polycarbonate housing. controlgear housing, CRCA sheet steel controlgear tray with a stove enamelled white reflector. A clear acrylic cover of dish shape, secured to canopy by stainless steel toggle and neoprene gasket lining, shall be provided at the bottom.



**TECHNICAL SPECIFICATION FOR
LIGHTING FIXTURES, LAMPS &
MISCELLANEOUS ITEMS**

SPECIFICATION NO. PE-SS-999-558-E006

VOLUME II

SECTION II

REVISION: 0

DATE: 08.09.2016

SHEET 13 OF 38

- Luminaires for drip proof environment such as street lighting fluorescent luminaire shall have sheet aluminium canopy, a detachable reflector-cum-controlgear housing, clear ribbed acrylic cover held in aluminium frame. Luminaire shall have the degree of protection IP:55 unless mentioned otherwise in Data Sheet A. Luminaire shall be suitable for side entry mounting with the pole bracket arm.

e) Bay Type Luminaires

- Luminaires shall be designed for following indoor applications:
 - i) High bay
 - ii) Medium bay
 - iii) Low bay
- Luminaires shall have top mounted, cast aluminium controlgear housing. Housing shall have cooling fins and canopy for easy access to the components. Canopy shall be hinged at one end and wing screw bolted at the other end.
- Controlgear shall be connected to the detachable lamp housing at the bottom such that heat dissipation is proper and distributed.
- Lamp housing-cum-reflector shall be made from spun aluminium, electrochemically brightened and anodised.
- Lamp housing for the dust laden environment shall be totally enclosed type. A clear toughened glass cover shall be attached to the lamp housing with an aluminium frame and neoprene gasket. Luminaire shall be provided with a safety chain for toughened glass.
- Mounting arrangement shall consist of MS brackets with an anti-vibration eye-bolt.
- Side mounted controlgear box shall be provided for low bay luminaires, if mentioned in "Luminaire Details".

f) Well Glass Luminaires

- Well glass luminaires shall be suitable for dust and vapour laden environment.
- Luminaires shall be provided with a die-cast aluminium canopy and heat resistant well glass, fitted with a ring type gasket.
- All well glass luminaires shall be provided with vitreous enamelled reflector.
- Zinc plated MS wire guard shall be provided for protection of well glass.



**TECHNICAL SPECIFICATION FOR
LIGHTING FIXTURES, LAMPS &
MISCELLANEOUS ITEMS**

SPECIFICATION NO. PE-SS-999-558-E006

VOLUME II

SECTION II

REVISION: 0

DATE: 08.09.2016

SHEET 14 OF 38

- Separate side mounted and top connected control gear box shall be provided for use with HPMV & HPSV lamps.
- Integral control gear box, where applicable, shall be of die cast aluminium material with one piece neoprene gasket between the box and its cover to make it dust and vapour proof.
- Luminaires shall be conduit mounted type for incandescent lamps and surface mounting type for HPMV & HPSV lamps.

g) Flame Proof Well Glass Luminaires

- Housing material shall be cast aluminium alloy LM6. Housing outer surface shall be provided with cooling fins.
- Flame proof luminaires shall be provided with heavy toughened well glass cemented in a retaining ring.
- Zinc-coated / chrome-plated MS chain connected to the main body and glass retaining ring shall be provided.
- A detachable terminal box at the top shall be provided.
- Neoprene gaskets, where needed, shall be provided for weather proof construction and indoor and outdoor application.
- Two cable entries of 20mm ET conduit shall be provided with one flame proof plug.
- Luminaires shall be suitable for the hazardous areas as classified in Data Sheet A. Design of flame proof luminaire shall be supported by the type test report for flame proofness from a government or government approved independent laboratory.

h) Street Lighting Luminaires (Other than Fluorescent Luminaire)

- These luminaires shall be suitable for street lighting and general purpose outdoor area lighting.
- Luminaire housing shall be one piece cast aluminium alloy to accommodate lamp housing and controlgear for lamp wattage upto 150 watts. For lamp wattage above 150 watts, controlgear housing shall be of cast aluminium alloy whereas lamp housing shall be of deep drawn aluminium.
- Inside finish of the lamp housing shall be stove enamelled white. Optical control shall be provided with two high purity, electro brightened and anodised side reflectors.



**TECHNICAL SPECIFICATION FOR
LIGHTING FIXTURES, LAMPS &
MISCELLANEOUS ITEMS**

SPECIFICATION NO. PE-SS-999-558-E006

VOLUME II

SECTION II

REVISION: 0

DATE: 08.09.2016

SHEET 15 OF 38

- Clear acrylic bowl fitted with a rubber gasket and easily removable type shall be secured to the lamp housing.
- Provision shall be made for adjustment of lamp location for proper focussing.
- Luminaires shall be suitable for mounting with pole bracket arm.

i) Flood Lighting Luminaires

- Flood light lamp housing and reflector shall be separate from controlgear box. Requirements of controlgear box are specified elsewhere.
- Lamp reflectors shall be of high purity spun aluminium attached to the cast aluminium lamp holder housing at the rear. Lamp holder housing shall be provided with cooling fins.
- Reflector shall be closed from the front by heat resistant toughened glass and synthetic "S" type weather proof gasket.
- Luminaire shall be provided with special lamp centering and focussing device ensuring good beam control.
- MS mounting bracket shall allow fixation of the flood light in any position in a horizontal plane and the flood light can be locked in at any set angle in the vertical plane. Cast iron base and / or two protector scales shall also be provided where specified in "Luminaire Details"
- Design shall permit replacement of lamp from the rear without disturbing the previously set aiming angles. Special guide pins shall also be provided for protecting the lamps from damage while replacing.

j) Halogen Flood Lighting Luminaire

- Luminaires shall be compact in design with aluminium alloy housing and three piece highly polished and anodised reflector assembly.
- Toughened glass panel in the front shall be provided with silicon gaskets.
- Lamp replacement from the front is also acceptable.

k) Post Top Lanterns

- Luminaire shall comprise of a spun aluminium canopy, opal acrylic diffuser and a cast aluminium spigot.
- Controlgear shall be integral type and shall be housed in the spigot.
- Luminaire shall be supplied without mounting pole.



**TECHNICAL SPECIFICATION FOR
LIGHTING FIXTURES, LAMPS &
MISCELLANEOUS ITEMS**

SPECIFICATION NO. PE-SS-999-558-E006

VOLUME II

SECTION II

REVISION: 0

DATE: 08.09.2016

SHEET 16 OF 38

l) Bulk Head (Flame Proof)

- Bulk head luminaires shall be used for the locations where explosion or fire hazard exists.
- Luminaire shall be made of cast iron housing with integral terminal box.
- Front of the luminaire shall be covered with flat toughened glass cemented into a retaining ring.
- Lamp replacement shall be from the front.
- Controlgear box for HPMV lamps shall be integral to the housing.
- MS fixing straps shall be provided for mounting.
- Luminaire shall be stove enameled grey outside and white inside.
- Terminal box shall be provided with 20 mm ET conduit entry.
- Complete luminaire shall be suitable for the hazardous area as classified in Data Sheet A. Type test certificate for flame proofness test from government or government approved independent laboratory shall be submitted.

m) Bulk Head (Weather Proof)

- Luminaire shall be suitable for indoor / outdoor applications having weather proof features.
- The luminaire shall comprise of die cast aluminium alloy body of dish shape.
- Luminaire shall have a heat resistant prismatic cover held in a weather proof gasket.
- Luminaire shall be stove enamelled grey outside and white inside.
- Glass cover shall have a galvanised wire protection.
- Luminaire shall be provided with locking arrangement with Allen key to prevent pilferage.
- Luminaire shall be suitable for use with incandescent lamp upto 100W.
- Provision for 20 mm ET conduit entry shall be provided at the bottom.



**TECHNICAL SPECIFICATION FOR
LIGHTING FIXTURES, LAMPS &
MISCELLANEOUS ITEMS**

SPECIFICATION NO. PE-SS-999-558-E006

VOLUME II

SECTION II

REVISION: 0

DATE: 08.09.2016

SHEET 17 OF 38

n) LED type Luminaires:

- LED Luminaires shall be used for the lighting if specified in BOQ as part of NIT.
- In false ceiling area LED luminaires shall be recessed mounting type & in non-false ceiling area the LED luminaires shall be surface mounting type.
- The individual lamp wattage for LED shall be upto 3 watt.
- The LED chip efficacy shall be min 120 Lm/W. The luminaire efficacy shall be not less than 70Lm/W.
- The LED used in the luminaires shall have colour rendering index (CRI) of Min 65. Colour designation of LED shall be "cool day light" (min 5700K) type.
- The LED luminaire shall have minimum life of 25,000 burning hours with 80% of lumen maintenance at the end of the life.
- The beam angle for LED chip shall be 120 degrees.
- The max. junction temperature of LED shall be 85 deg C, further the lumen maintenance at this temperature shall be min 90%.
- The THD of LED Luminaires shall be less than 10%. Further the EMC shall be as per IS 14700. The power factor of the luminaire shall not be less than 0.9.
- The marking on luminaire & safety requirements of luminaire shall be as per IS standards.
- Suitable heat sink with proper thermal management shall be designed & provided in the luminaire.
- The connecting wires used inside the system, shall be low smoke halogen free, fire retardant PTFE cable.
- Fuse protection shall be provided in input side specifically for LED luminaires.
- Care shall be taken in the design that there is no water stagnation anywhere. The entire housing shall be dust and water proof protection as per IS 12063.
- Driver Circuit: LED modules and drivers shall be compatible to each other. The LED module driver's ratings and makes shall be as recommended by corresponding LED manufacturer. LED Drivers may have following control & protections:
 - Suitable precision current control of LED.
 - Open Circuit Protection



TECHNICAL SPECIFICATION FOR LIGHTING FIXTURES, LAMPS & MISCELLANEOUS ITEMS

SPECIFICATION NO. PE-SS-999-558-E006

VOLUME II

SECTION II

REVISION: 0

DATE: 08.09.2016

SHEET 18 OF 38

- Short Circuit Protection
- Over Temperature Protection
- Overload Protection

o) Emergency Lighting Luminaires

- The luminaire shall be automatic having in-built battery.
- Battery shall have integral charging unit.
- Charger shall be suitable for operation as per system design data.
- The battery enclosure shall be suitably painted and ventilated for the performance with sealed lead acid battery, as applicable.

5.3 CONTROLGEAR BOX (NON-INTEGRAL TYPE)

- a) Boxes shall have weatherproof construction and shall be provided with one piece neoprene gasket.
- b) Boxes shall be provided with HRC fuse mounted on a removable tray. Boxes shall be provided with all necessary components having a neat layout arrangement such that it is possible to test, inspect or replace any component without difficulty.
- c) Boxes shall be suitable for mounting on structures, walls and columns.
- d) Suitable number of terminals shall be provided for looping-in and looping-out of cable connections and also connections to the luminaire(s).
- e) Cable / conduit knock-outs shall be for each loop-in and loop-out connection and also connection to the luminaire(s).

5.4 REFLECTORS

- a) Reflectors shall be made of sheet steel or aluminium as applicable.
- b) The aluminium reflectors shall be made of high purity aluminium sheet. Sheet will be polished, electrochemically brightened and anodised.
- c) Wherever reflectors are separate from housing, they shall be securely attached to the luminaire by means of easily accessible fastening devices such that they are readily removable from the housing for maintenance.



**TECHNICAL SPECIFICATION FOR
LIGHTING FIXTURES, LAMPS &
MISCELLANEOUS ITEMS**

SPECIFICATION NO. PE-SS-999-558-E006

VOLUME II

SECTION II

REVISION: 0

DATE: 08.09.2016

SHEET 19 OF 38

5.5 LAMP HOLDERS

- a) Holders shall be resistant to wear and shall be smooth in operation.
- b) Contacts shall be of durable quality.
- c) Holders shall hold the lamp under condition of shock and vibration.
- d) Lamp holders for fluorescent lamp shall be spring loaded, bi-pin, rotor type with low contact resistance.
- e) Live parts of the holder shall not be exposed when the lamp is inserted or removed in case of fluorescent luminaires.
- f) Lamp holders for HPMV & HPSV lamps shall be of porcelain material.
- g) Holders shall be screw type for HPSV & HPMV lamps. Holders for incandescent lamps shall be screw type, unless mentioned otherwise in Data sheet A.
- h) Lamp holders for incandescent lamps shall be of brass or porcelain.

5.6 STARTER HOLDERS

- a) Starter holders shall be designed and manufactured as per the applicable standard.

5.7 BALLASTS

- a) Fluorescent fixtures shall have electronic ballasts. Ballasts shall be totally enclosed type.
- b) Ballasts shall be easily removable type.
- c) Core shall be made of low loss, electrical grading stampings.
- d) End connections shall be made available in a terminal block, rigidly fixed to the ballast enclosure.
- e) Ballasts shall be free from humming.
- f) Ballast shall be provided separately for each lamp in a multi-lamp luminaire.
- g) Tappings shall be provided to set the voltage within range for HPMV & HPSV luminaires.

5.8 STARTERS

- a) Starters shall be made of aluminium material. Plastic or any other material if used shall be subject to purchaser's approval.
- b) Starters shall have bi-metal electrodes.



**TECHNICAL SPECIFICATION FOR
LIGHTING FIXTURES, LAMPS &
MISCELLANEOUS ITEMS**

SPECIFICATION NO. PE-SS-999-558-E006

VOLUME II

SECTION II

REVISION: 0

DATE: 08.09.2016

SHEET 20 OF 38

- c) Starter shall be replaceable without the use of any tool and without disturbing any accessory or lamp.
- d) Starters shall have high mechanical strength.
- e) Starters shall be provided with radio interference suppressing capacitors.
- f) Starters shall have brass contacts.

5.9 CAPACITORS

- a) Capacitors shall have constant value of capacitance, suitable for operation at supply voltage.
- b) Capacitors shall be hermetically sealed, preferably in a metal enclosure to prevent seepage of impregnant and ingress of moisture.

5.10 LAMPS

- a) Lamps shall be suitable for use in any position.
- b) Lamps shall be capable of withstanding small vibrations without breakage to filaments / electrodes and lead-in wire.

5.10.1 Type of Lamps

- a) Fluorescent Lamp
 - i. Anode rings shall be provided to prevent blackening of the ends.
 - ii. Lamp caps shall be two pin type at each end.
- b) Incandescent (GLS) Lamps
 - i. Incandescent lamps shall be "clear" type.
- c) Mercury Vapour Lamps
 - i. Lamp caps shall be screw type.
- d) Sodium Vapour Lamps
 - i. Lamps shall be ovoid shaped with diffusing powder coating.
 - ii. Lamps shall be provided with external igniters and rapid restart facility.
 - iii. Lamp caps shall be screw type.



**TECHNICAL SPECIFICATION FOR
LIGHTING FIXTURES, LAMPS &
MISCELLANEOUS ITEMS**

SPECIFICATION NO. PE-SS-999-558-E006

VOLUME II

SECTION II

REVISION: 0

DATE: 08.09.2016

SHEET 21 OF 38

e) Halogen Lamps

- i. Lamps shall be double ended linear type.
- ii. Lamps shall be of immediate start type.
- iii. Design of lamps shall ensure high performance and high efficiency.

5.11 JUNCTION BOXES

a) Junction boxes with terminals shall be supplied for branching and terminating lighting wires/cables whenever required, as specified.

b) Construction Features

- i. The junction boxes shall be fabricated out of material & thickness as specified in Datasheet-A and shall be of rectangular shape. The cover shall be hinged or bolted with captive nuts and bolts and shall be provided with neoprene gasket lining all over.
- ii. The junction boxes shall be provided with suitable knock outs/ gland plates for conduit/ cable connection. The conduit connection shall be properly sealed. The junction boxes meant for cable connection shall be complete with removable gland plates, glands and cable lugs, as required. The junction boxes shall be provided with two earthing terminals suitable for GI earthing wires.
- iii. The junction boxes shall be weather proof type conforming to IP-55..
- iv. The boxes and cover shall be hot dip galvanised. Junction boxes for corrosive areas like DM Plant, water treatment plant etc. shall have additional epoxy/acrylic coating of thickness not less than 50microns on outer surface.
- v. The junction boxes shall be suitable for mounting on wall, columns, etc. The brackets, bolts, nuts, screws and any other erection accessories required for erection shall be included.

c) Terminals

- i. Multiway terminal blocks of approved type and make complete with galvanised screws, nuts, washers and marking strips shall be furnished for terminating the lighting wires.
- ii. All the terminals blocks shall be of 650V grade one piece construction with insulating barriers. These terminals shall be made of copper alloy and shall be stud type. Each terminal provided on junction box shall be suitable for terminating two numbers of aluminium conductors of the size as specified without any damage to the conductors or looseness.



**TECHNICAL SPECIFICATION FOR
LIGHTING FIXTURES, LAMPS &
MISCELLANEOUS ITEMS**

SPECIFICATION NO. PE-SS-999-558-E006

VOLUME II

SECTION II

REVISION: 0

DATE: 08.09.2016

SHEET 22 OF 38

d) The junction boxes shall be of following types:

Type	Description
JB-F	Provided with four (4) way stud type terminals for terminating upto 2 nos. 10 mm ² stranded aluminium conductors on each terminal, suitable for outdoor installations.
JB-FE	Same as above but with an additional epoxy coating of 50 micron thickness.
JB-S	Provided with four (4) way stud type terminals, each terminal suitable for terminating upto two nos. of 3.5Cx50 mm ² stranded aluminium conductors & with one no.6A HRC fuse and link.

5.12 RECEPTACLES

- a) Receptacle unit shall consist of socket outlet with associated switch and plug. The socket outlet and switch shall be flush mounted on a box which shall be suitable for mounting on wall or steel structures.
- b) Receptacle boxes shall be fabricated from material with thickness mentioned in Data Sheet A.
- c) Steel boxes shall be hot dip galvanised/ painted as specified in Datasheet-A and as per the requirements of applicable standard corresponding to the sheet thickness.
- d) The boxes shall have conduit knock-outs and shall be suitable for cable entry of the size to be specified by purchaser during detailed engineering.
- e) The boxes shall be provided with neoprene rubber gaskets to make them moisture and dust proof.
- f) Suitable loop-in and loop-out terminals shall be provided inside the box. Terminals for incoming and outgoing shall be suitable for the size of conductor of cables.
- g) The receptacle units shall be of the following types:
 - I. Type RA: It shall have the following:
 - i. 20A, 240V, 1-phase, 2 pole, 3-pin (third pin scrapping earth) porcelain, metal clad socket with a metallic cover tied to it.
 - ii. Rotary, heavy duty 20A switch conforming to applicable standard.
 - iii. Shrouded, die-cast aluminium plug.
 - iv. It shall be combined interlocked weather proof industrial unit.



**TECHNICAL SPECIFICATION FOR
LIGHTING FIXTURES, LAMPS &
MISCELLANEOUS ITEMS**

SPECIFICATION NO. PE-SS-999-558-E006

VOLUME II

SECTION II

REVISION: 0

DATE: 08.09.2016

SHEET 23 OF 38

v. Mechanical interlock shall be provided as follows :

- Switch can be put ON only when plug is fully engaged.
- Plug can be withdrawn only when switch is in OFF position.
- Cover can be opened only when switch is in OFF position.

vi. The arrangement should ensure that water does not enter the plug when socket is ON.

vii. Loop-in loop-out terminals shall be provided inside the box suitable for 10 mm² Al conductor.

II. Type RB: It shall have the following:

- i. Combination of 5A & 15A, 240V, 1-phase, 2 pole, 3-pin, third pin grounded socket with integral piano key type 15A switch, flush mounted on decorative bakelite (6 mm thick)/ perspex (3 mm thick) sheet as cover of the boxes.
- ii. Loop-in loop-out terminals similar to type RA shall be provided. These will be located in office areas.

III. Type RC: It shall have the following:

- i. 63A, 415V, 3-phase-neutral earth, metal clad socket with cover
- ii. Rotary, heavy duty 63A switch conforming to applicable standard.
- iii. Shrouded, die-cast aluminium plug
- iv. It shall be combined, interlocked weather proof industrial unit.
- v. Mechanical interlock shall be same as that are applicable for RA type receptacles
- vi. The receptacle boxes shall be suitable for entry and exit of 3.5CX70 mm² Al conductor PVC cable and loop-in loop-out terminals for the same shall be provided such that not more than one core is terminated at one terminal. Removable, undrilled cable gland plate shall be provided. Tinned copper lugs and double compression cable glands shall also be supplied by the bidder.

IV. Type RD: It shall have the following:

- i. 125A, 415V, 3-phase-neutral earth, metal clad socket with cover.
- ii. Rotary, heavy duty 125A switch conforming to applicable standard.
- iii. Shrouded, die-cast aluminium plug



**TECHNICAL SPECIFICATION FOR
LIGHTING FIXTURES, LAMPS &
MISCELLANEOUS ITEMS**

SPECIFICATION NO. PE-SS-999-558-E006

VOLUME II

SECTION II

REVISION: 0

DATE: 08.09.2016

SHEET 24 OF 38

- iv. It shall be combined, interlocked weather proof industrial unit.
- v. Mechanical interlock shall be same as that are applicable for RC type receptacles
- vi. The receptacle boxes shall be suitable for entry and exit of 3.5CX95 mm² Al conductor PVC cable and loop-in loop-out terminals for the same shall be provided such that not more than one core is terminated at one terminal. Removable, undrilled cable gland plate shall be provided. Tinned copper lugs and double compression cable glands shall also be supplied by the bidder.

V. Type RE: It shall have the following:

- i. 5A, 240V, 1-phase, 2 pole, 3-pin, third pin grounded socket with integral piano key type 5A switch, flush mounted on decorative bakelite (6 mm thick)/ perspex (3 mm thick) sheet as cover of the boxes.
- ii. Loop-in loop-out terminals similar to type RA shall be provided. These will be located in office areas.

5.13 CEILING FAN & REGULATORS

- a) The bidder shall supply the following ceiling fans complete with suspension rod, canopy and accessories and regulators:
 - i. 1200 mm sweep
 - ii. 1400 mm sweep
- b) The fan motor shall be totally enclosed. The motor winding shall be of copper wire provided with double or reinforced class-E insulation.
- c) The fan shall have three (3) well balanced blades. Precaution shall be taken in the manufacture of fan as well as regulators to ensure reasonable degree of silence at all speeds.
- d) The regulator shall be electronic type with stepped/smooth (stepless) control of approved make.

5.14 LIGHTING CONTROL SWITCH-BOXES

- a) The switch-boxes shall be of bent steel construction, fabricated of 1.6 mm thick MS steel with 6 mm thick decorative bakelite or 3 mm thick perspex sheet cover. The boxes shall be hot dip galvanised.
- b) The switch-boxes shall be suitable for surface mounting as well as flush mounting in brick walls. They shall be flush mounted in the walls in the office areas where false ceiling is provided.



**TECHNICAL SPECIFICATION FOR
LIGHTING FIXTURES, LAMPS &
MISCELLANEOUS ITEMS**

SPECIFICATION NO. PE-SS-999-558-E006

VOLUME II

SECTION II

REVISION: 0

DATE: 08.09.2016

SHEET 25 OF 38

- c) Switch-boxes shall have conduit knock-out on two sides. Adequate provision shall be made for ventilation of these boxes. Conduit knock-out sizes shall be as per conduit layout drgs.
- d) Switches shall be of piano-key type having quick-make, quick-break mechanism, provided with position marking, suitable for mounting on insulating plate. The switches shall be suitable for 1-phase, 240V, 50 Hz supply. They shall conform to relevant standards. The switches shall be supplied loose and shall be fixed at site according to requirement.
- e) All components housed in the switch-boxes shall be wired to an outgoing junction box by 1.5 mm² Cu wire. The junction box shall have adequate nos. of terminals.
- f) The size of switch-boxes shall be adequately chosen to accommodate the no. of switches and fan regulator boxes specified below. Fan regulators shall be supplied separately.
- i. Type SWB1 - Switch board with 1 no. 5A switch, JB type SW1.
 - ii. Type SWB2 - 3 nos. 5A switches and 1 no. fan regulator, JB type SW2.
 - iii. Type SWB3 - 7 nos. 5A switches, 3 nos. fan regulator, JB type SW3.
 - iv. Type SWB4 - 4 nos. 5A switches, JB type SW2.
 - v. Type SWB5 - 8 nos. 5A switches, JB type SW3.

JB details for lighting control switch boxes are as below:

JB-SW1 Provided with four (4) way stud type terminals, each terminal suitable for terminating upto two nos. of 10 mm² stranded aluminium conductor.

JB-SW2 Similar to the JB-SW1 but provided with ten (10) way terminals.

JB-SW3 Similar to the JB-SW1 but provided with eighteen (18) way terminals.

5.15 CABLE GLANDS

- a) Whether specifically mentioned or not, cable glands of suitable sizes shall be supplied along with each equipment for power and control cables.
- b) Rubber components used in the gland shall be of neoprene.
- c) Name / trade name of manufacturer, type no. and applicable range of outer diameter of cable shall be engraved / indelibly printed on the cable gland.

5.16 CABLE LUGS

- a) All equipment shall be supplied with the power and control cable lugs of suitable size, whether specifically mentioned or not.



**TECHNICAL SPECIFICATION FOR
LIGHTING FIXTURES, LAMPS &
MISCELLANEOUS ITEMS**

SPECIFICATION NO. PE-SS-999-558-E006

VOLUME II

SECTION II

REVISION: 0

DATE: 08.09.2016

SHEET 26 OF 38

- b) Name / trade name and size of lug shall be engraved/ indelibly printed on each cable lug.

5.17 FLEXIBLE METALLIC CONDUITS AND FITTINGS

- a) Flexible metallic conduits shall generally conform to the requirements of IS:3480.
- b) Flexible conduits shall be made of strip steel, which shall be of cold rolled mild steel. The strip shall be of uniform width and thickness throughout.
- c) The strip for making flexible conduit shall be wound tightly and so overlapped in subsequent helicals that no openings are seen in normal position.
- d) The surface of the strip shall be thoroughly cleaned before application of protective coating. Pre-treatment, before galvanization, shall conform to IS:6005.
- e) The strip shall be electro-galvanized to a minimum thickness of 25 microns as per IS 3480.
- f) Flexible conduits shall be lead coated for application in high temperature zones if specifically mentioned in Data Sheet A.
- g) The conduit shall have uniform diameter throughout its length. The internal surface of all conduits shall be free from burrs and sharp edges and suitable for pulling insulated cables and wires without damage.

5.18 PVC CONDUITS

- a) PVC conduits shall generally conform to the requirements of IS: 9537(Part I & Part III).

6.0 SURFACE TREATMENT

- 6.1 All metal parts and the surfaces (exterior & interior) of equipment, unless stated otherwise in case of reflectors, shall be degreased by dipping in hot alkaline solution and rubbed with wire brush to remove oil & scale from them & then rinsed in water. Alternatively, they may be shot / sand blasted.
- 6.2 Parts shall be pickled by dipping in hydrochloric acid tank to remove the rust from the surfaces formed during storage of sheets & then rinsed to remove traces of the acid. The cleaning and pretreatment of all metal parts shall be as per applicable standard.
- 6.3 The surfaces to be painted shall then be prepared by phosphatizing to protect them from further rusting & to create a good bond with the paint. The pretreatment shall conform to the applicable standard.
- 6.4 All parts shall then be subjected to a coat of red oxide primer paint.
- 6.5 All inside and outside surfaces of panel shall be spray painted with synthetic enamel of the shade as per Data Sheet A.



**TECHNICAL SPECIFICATION FOR
LIGHTING FIXTURES, LAMPS &
MISCELLANEOUS ITEMS**

SPECIFICATION NO. PE-SS-999-558-E006

VOLUME II

SECTION II

REVISION: 0

DATE: 08.09.2016

SHEET 27 OF 38

- 6.6 Electrostatic or powder painting shall be acceptable subject to purchaser's approval.
- 6.7 Wherever possible, finished parts shall be coated with peelable compound by spraying method to protect the finished product from scratches, grease, dirty and oily spots during handling and transportation.
- 7.0 PACKING**
- 7.1 Vendor shall furnish packing procedure along with packing drawing at contract stage for applicable items for purchaser approval.
- 7.2 Containers adequate for storing 70% of P.O. quantity material at site are to be supplied. Vendor shall furnish suitable justification to purchaser during detailed engineering for the number and size of containers being supplied.
- 7.3 Specification for the sea worthy packing, if enclosed, for the export jobs shall form part of the specification.
- 8.0 GUARANTEED PERFORMANCE REQUIREMENTS**
- 8.1 The vendor shall guarantee satisfactory performance of the equipment supplied under all conditions and requirement as laid down by this specification.
- 8.2 Vendor shall ensure satisfactory performance for lighting system designed by them at site.
- 9.0 INSPECTION & TESTING**
- 9.1 Bidder shall confirm compliance with the BHEL Standard Quality Plan (PE-QP-999-558-E006) without any deviations. The equipment which are not covered in the Quality Plan shall be tested as per the QP to be submitted by bidder. In case bidder has reference QP agreed with ultimate customer, same can be submitted for specific project after award of contract for BHEL/ ultimate customer's approval. There shall be no commercial implication to BHEL on account of any changes in QP during contract stage.
- 9.2 All the components and completely assembled equipment shall be tested as per the latest edition of standards. Charges for these tests shall be deemed to be included in equipment price.
- 9.3 All the specified type and routine tests shall be carried out to verify the rating and performance of the equipment. Where valid type test certificates in evidence of equipment performance claimed are available & approved by purchaser, the requirements for conducting type tests may be waived. The general arrangement of object under test shall be to purchaser's approval.
- 9.4 All manufacturing processes viz. machining, sheet forming, electroplating, wire routing, cleating & crimping, assembly, surface preparation shall conform to good manufacturing practices.



**TECHNICAL SPECIFICATION FOR
LIGHTING FIXTURES, LAMPS &
MISCELLANEOUS ITEMS**

SPECIFICATION NO. PE-SS-999-558-E006

VOLUME II

SECTION II

REVISION: 0

DATE: 08.09.2016

SHEET 28 OF 38

- 9.5 Inspection for dimensional & visual checks especially of the following, with respect to contract drawings, documents & standards shall be conducted:
- General sturdiness & rigidity of equipment
 - Surface finishing
 - Gasketting
 - Inter-changeability
 - Constructional features viz. location, accessibility & marking of components, segregation, accessibility to live parts (shrouding) etc.
 - Completeness of scope
- 9.6 Equipment shall be liable for rejection if tolerances on the values of dimensions, power consumption, impedances, temperature rise etc. exceed the specified values by purchaser and / or standards.

10.0 SPARES

- 10.1 Mandatory spares (if applicable) are indicated in BOQ-cum-price schedule.
- 10.2 Erection & commissioning spares are included in the bidder's scope of supply. BE&C spares are indicated in BOQ-cum-price schedule.
- 10.3 A list of recommended O&M spares quantities for a duration of 3 years A shall be filled up in the applicable schedule / format and submitted by bidder along with offer. However, the acceptance of the same shall not be binding on purchaser.

11.0 TOOLS AND TACKLE

- 11.1 Tools & tackle which are essential to facilitate assembly, adjustments, erection, maintenance & dismantling of equipment shall be provided as part of equipment supplied.
- 11.2 The above tools shall be supplied along with the initial consignment of equipment so as to be available prior to erection but may not be used for erection purposes.
- 11.3 Vendor shall also submit a list of recommended tools and tackle. Acceptance of these tools and tackle shall not be a binding on the purchaser.
- 11.4 Schedule of tools & tackle shall be filled up by bidder.

12.0 DOCUMENTATION

12.1 Documents to be submitted by the vendor immediately after award of contract

- Bar chart of activities of manufacture, testing, inspection and despatch.

12.2 Documents to be submitted during detailed engineering of contract

- 12.2.1 Engineering documents (refer clause 4.3) to be generated by the vendor, if applicable.



**TECHNICAL SPECIFICATION FOR
LIGHTING FIXTURES, LAMPS &
MISCELLANEOUS ITEMS**

SPECIFICATION NO. PE-SS-999-558-E006

VOLUME II

SECTION II

REVISION: 0

DATE: 08.09.2016

SHEET 29 OF 38

- a) Lighting calculations for indoor areas.
- b) Lighting calculations for outdoor areas.
- c) SLD of power distribution upto LPs.
- d) Power load on each LP & LDB
- e) Layout drawings for indoor areas
- f) Layout drawings for outdoor areas.
- g) Conduit layout drawings.
- h) Wiring and load distribution details for outdoor areas.
- i) Master Bill of Material.
- j) Packing Procedure & drawing.
- k) Calculation for selection of no. & size of container.

12.2.2 Other documents :

- a) Final Quality Plans
- b) Technical data sheet
- c) Polar curves, zonal flux diagram and CoU charts of luminaires.
- d) Complete design calculations for arriving at number of luminaires.
- e) Fixing / mounting details of luminaires and other items.
- f) General arrangement drawings of following:
 - i. Luminaires
 - ii. Receptacles
 - iii. 24 V Supply module
- g) Field Quality Plan as per General Technical Conditions.
- h) Control Scheme for fluorescent, HPMV and HPSV luminaires.
- i) Schematic drawings for LDBs / LPs.
- j) Type test certificates.
- k) Catalogues / leaflets

12.3 Operation and Maintenance (O&M) manual :

The document shall comprise of installation, operating and maintenance instructions for various items / components. The O&M manual shall include the following :

- a) Write ups / instructions / procedures for
 - i. Storage at site.
 - ii. Unpacking.
 - iii. Handling at site.



**TECHNICAL SPECIFICATION FOR
LIGHTING FIXTURES, LAMPS &
MISCELLANEOUS ITEMS**

SPECIFICATION NO. PE-SS-999-558-E006

VOLUME II

SECTION II

REVISION: 0

DATE: 08.09.2016

SHEET 30 OF 38

- iv. Erection.
- v. Pre-commissioning / commissioning tests.
- vi. Operating procedures.
- vii. Maintenance procedures.
- viii. Precautions to be taken during operation and maintenance work.
- ix. Trouble shooting charts covering problems, cause and solution.
- b) Approved Technical Data Sheets.
- c) Technical leaflet of various items / components.
- d) Copies of the type, acceptance and routine test certificates in bound volume.
- e) Details of all components liable to be replaced during the life of the equipment.
- f) List of maintenance tools required.
- g) List of testing equipment required.

12.4 AS BUILT DRAWINGS

- a) Preparation of as-built drawings shall be in the scope of vendor.
- b) The as-built drawings shall be prepared on the basis of marked up copies received from the erection contractor.
- c) Entire work of as-built drawings shall be to the satisfaction of purchaser.



**TECHNICAL SPECIFICATION FOR
LIGHTING FIXTURES, LAMPS &
MISCELLANEOUS ITEMS**

SPECIFICATION NO. PE-SS-999-558-E006

VOLUME II

SECTION II

REVISION: 0

DATE: 08.09.2016

SHEET 32 OF 38

1.0 Fluorescent Lamp Luminaires

- | | | | |
|------|------|--------|---|
| 1.1 | FC01 | 1 x 28 | Fluorescent, industrial box type base without any cover. |
| 1.2 | FC02 | 2 x 28 | Fluorescent, industrial box type base without any cover. |
| 1.3 | FC03 | 1 x 28 | Fluorescent, industrial box type base and stove enamelled side reflectors. |
| 1.4 | FC04 | 2 x 28 | Fluorescent, industrial box type base and stove enamelled side reflectors. |
| 1.5 | FC05 | 1 x 28 | Fluorescent, industrial box type base and vitreous enamelled side reflectors. |
| 1.6 | FC06 | 2 x 28 | Fluorescent, industrial box type base and vitreous enamelled/ anodized glossy side reflectors. |
| 1.7 | FC07 | 1 x 18 | Fluorescent, industrial box type base and vitreous enamelled side reflectors operating on 220V DC input supply. |
| 1.8 | FC21 | 1 x 28 | Fluorescent, decorative with 3 side perspex acrylic diffuser. |
| 1.9 | FC22 | 2 x 28 | Fluorescent, decorative with 3 side perspex acrylic diffuser. |
| 1.10 | FC23 | 1 x 28 | Fluorescent, decorative, recessed type with perspex acrylic diffuser. |
| 1.11 | FC24 | 2 x 28 | Fluorescent, decorative, recessed type with perspex acrylic diffuser. |
| 1.12 | FC25 | 1 x 28 | Fluorescent, decorative, recessed type with mirror optic reflector. |
| 1.13 | FC26 | 2 x 28 | Fluorescent, decorative, recessed type with mirror optic reflector. |
| 1.14 | FC27 | 2 x 28 | Fluorescent, decorative with opal polystyrene louvers. |
| 1.15 | FC28 | 2 x 28 | Fluorescent, decorative, recessed type with opal polystyrene louvers. |
| 1.16 | FC29 | 2 x 28 | Fluorescent, decorative with vertical metallic louvers. |
| 1.17 | FC30 | 4 x 14 | Fluorescent, decorative, recessed type, 600 x 600 size with perspex acrylic diffuser. |
| 1.18 | FC31 | 4 x 20 | Fluorescent, decorative, recessed type, 600 x 600 size with opal polystyrene louvers. |



**TECHNICAL SPECIFICATION FOR
LIGHTING FIXTURES, LAMPS &
MISCELLANEOUS ITEMS**

SPECIFICATION NO. PE-SS-999-558-E006

VOLUME II

SECTION II

REVISION: 0

DATE: 08.09.2016

SHEET 33 OF 38

- | | | | |
|------|------|--------|---|
| 1.19 | FC32 | 2 x 28 | Fluorescent, decorative, surface mounted with mirror optic reflector. |
| 1.20 | FC33 | 1 x 18 | Fluorescent, decorative, recessed type with mirror optic reflector operating on 220V DC input supply. |
| 1.21 | FC34 | 1 x 18 | Fluorescent, dust proof, totally enclosed type with sheet steel housing operating on 220V DC input supply |
| 1.22 | FC41 | 2 x 28 | Fluorescent, vapour proof with end boxes and controlgear box of cast Al. |
| 1.23 | FC51 | 2 x 28 | Fluorescent, dust proof, totally enclosed type with sheet steel housing. |
| 1.24 | FC61 | 1 x 28 | Fluorescent, street light with sheet aluminium canopy and ribbed acrylic cover. |
| 1.25 | FC62 | 2 x 28 | Fluorescent, street light with sheet aluminium canopy and ribbed acrylic cover. |
| 1.26 | FC81 | 2 x 28 | Fluorescent, corrosion proof, totally enclosed type with sheet aluminium/ polycarbonate housing. |

2.0 High Pressure Mercury Vapour (HPMV) Lamp Luminaire

- | | | | |
|------|------|----------|--|
| 2.1 | MB01 | 1 x 250 | Mercury, high bay, industrial type. |
| 2.2 | MB02 | 1 x 400 | Mercury, high bay, industrial type. |
| 2.3 | MB03 | 1 x 1000 | Mercury, high bay, industrial type. |
| 2.4 | MB04 | 1 x 250 | Mercury, high bay, totally enclosed industrial type. |
| 2.5 | MB05 | 1 x 400 | Mercury, high bay, totally enclosed industrial type. |
| 2.6 | MB06 | 1 x 250 | Mercury, high bay with non-integral controlgear box. |
| 2.7 | MB07 | 1 x 400 | Mercury, high bay with non-integral controlgear box. |
| 2.8 | MB11 | 1 x 250 | Mercury, medium bay, industrial type. |
| 2.9 | MB12 | 1 x 400 | Mercury, medium bay, industrial type. |
| 2.10 | MB13 | 1 x 250 | Mercury, medium bay, totally enclosed industrial type. |
| 2.11 | MB14 | 1 x 400 | Mercury, medium bay, totally enclosed industrial type. |



**TECHNICAL SPECIFICATION FOR
LIGHTING FIXTURES, LAMPS &
MISCELLANEOUS ITEMS**

SPECIFICATION NO. PE-SS-999-558-E006

VOLUME II

SECTION II

REVISION: 0

DATE: 08.09.2016

SHEET 34 OF 38

2.12	MB17	1 x 80	Mercury, low bay, industrial type.
2.13	MB18	1 x 125	Mercury, low bay, industrial type.
2.14	MB19	1 x 80	Mercury, low bay, totally enclosed industrial type.
2.15	MB20	1 x 125	Mercury, low bay, totally enclosed industrial type.
2.16	MW41	1 x 80	Mercury, well glass, vapour proof with vitreous enamelled reflector.
2.17	MW42	1 x 125	Mercury, well glass, vapour proof with vitreous enamelled reflector.
2.18	MW51	1 x 80	Mercury, well glass, dust proof with vitreous enamelled reflector.
2.19	MW52	1 x 125	Mercury, well glass, dust proof with vitreous enamelled reflector.
2.20	MW91	1 x 80	Mercury, well glass, flame proof with vitreous enamelled reflector and cast aluminium alloy LM6 housing.
2.21	MW92	1 x 125	Mercury, well glass, flame proof with vitreous enamelled reflector and cast aluminium alloy LM6 housing.
2.22	MW93	1 x 80	Mercury, well glass, flame proof with vitreous enamelled reflector and cast aluminium alloy LM6 housing
2.23	MW94	1 x 125	Mercury, well glass, flame proof with vitreous enamelled reflector and cast aluminium alloy LM6 housing.
2.24	MW95	1 x 80	Mercury, well glass, flame proof increased safety luminaire with vitreous enamelled reflector and cast aluminium alloy LM6 housing for Div.-2 areas.
2.25	MW96	1 x 125	Mercury, well glass, flame proof increased safety luminaire with vitreous enamelled reflector and cast aluminium alloy LM6 housing for Div. 2 areas.
2.26	MW98	1 x 125	Mercury, well glass, flame proof increased safety luminaire with vitreous enamelled reflector and cast aluminium alloy LM6 housing
2.27	MS61	1 x 125	Mercury, street light with one piece cast aluminium body.
2.28	MS62	1 x 250	Mercury, street light with two piece cast aluminium body.
2.29	MS63	1 x 400	Mercury, street light with two piece cast aluminium body.



**TECHNICAL SPECIFICATION FOR
LIGHTING FIXTURES, LAMPS &
MISCELLANEOUS ITEMS**

SPECIFICATION NO. PE-SS-999-558-E006

VOLUME II

SECTION II

REVISION: 0

DATE: 08.09.2016

SHEET 35 OF 38

2.30	MF61	1 x 250	Mercury, flood light, general purpose.
2.31	MF62	1 x 400	Mercury, flood light, heavy duty type.
2.32	MF63	2 x 400	Mercury, flood light, heavy duty type.
2.33	MP21	1 x 80	Mercury, post top lantern
2.34	MP22	1 x 125	Mercury, post top lantern
3.0	High Pressure Sodium Vapour (HPSV) Lamp Luminaire		
3.1	SB01	1 x 150	Sodium, high bay, industrial type.
3.2	SB02	1 x 250	Sodium, high bay, industrial type.
3.3	SB03	1 x 400	Sodium, high bay, industrial type.
3.4	SB04	1 x 150	Sodium, high bay, totally enclosed industrial type.
3.5	SB05	1 x 250	Sodium, high bay, totally enclosed industrial type.
3.6	SB06	1 x 400	Sodium, high bay, totally enclosed industrial type.
3.7	SB07	1 x 150	Sodium, high bay with non-integral controlgear box.
3.8	SB08	1 x 250	Sodium, high bay with non-integral controlgear box.
3.9	SB09	1 x 400	Sodium, high bay with non-integral controlgear box.
3.10	SB11	1 x 150	Sodium, medium bay, industrial type.
3.11	SB12	1 x 250	Sodium, medium bay, industrial type.
3.12	SB13	1 x 150	Sodium, medium bay, totally enclosed industrial type.
3.13	SB14	1 x 250	Sodium, medium bay, totally enclosed industrial type.
3.14	SB17	1 x 70	Sodium, low bay, industrial type.
3.15	SB18	1 x 150	Sodium, low bay, industrial type.
3.16	SB19	1 x 70	Sodium, low bay, totally enclosed industrial type.
3.17	SB20	1 x 150	Sodium, low bay, totally enclosed industrial type.
3.18	SW41	1 x 70	Sodium, well glass, vapour proof with vitreous enamelled/ powder coated type reflector.



**TECHNICAL SPECIFICATION FOR
LIGHTING FIXTURES, LAMPS &
MISCELLANEOUS ITEMS**

SPECIFICATION NO. PE-SS-999-558-E006

VOLUME II

SECTION II

REVISION: 0

DATE: 08.09.2016

SHEET 36 OF 38

3.19	SW42	1 x 150	Sodium, well glass, vapour proof with vitreous enamelled/ powder coated type reflector.
3.20	SW51	1 x 70	Sodium, well glass, dust proof with vitreous enamelled reflector.
3.21	SW52	1 x 150	Sodium, well glass, dust proof with vitreous enamelled reflector.
3.22	SW91	1 x 70	Sodium, well glass, flame proof with vitreous enamelled reflector and cast aluminium alloy LM6 housing.
3.23	SW92	1 x 150	Sodium, well glass, flame proof with vitreous enamelled reflector and cast aluminium alloy LM6 housing.
3.24	SW93	1 x 70	Sodium, well glass, flame proof with vitreous enamelled reflector and cast aluminium alloy LM6 housing.
3.26	SW95	1 x 70	Sodium, well glass, flame proof increased safety luminaire with vitreous enamelled reflector and cast aluminium alloy LM6 housing for Div. 2 areas.
3.27	SW96	1 x 150	Sodium, well glass, flame proof increased safety luminaire with vitreous enamelled reflector and cast aluminium alloy LM6 housing for Div. 2 areas.
3.28	SS61	1 x 70	Sodium, street light with one piece cast aluminium body.
3.29	SS62	1 x 150	Sodium, street light with one piece cast aluminium body.
3.30	SS63	1 x 250	Sodium, street light with two piece cast aluminium body.
3.31	SS64	1 x 400	Sodium, street light with two piece cast aluminium body.
3.32	SF61	1 x 250	Sodium, flood light, general purpose.
3.33	SF62	1 x 400	Sodium, flood light, general purpose.
3.34	SF63	1 x 250	Sodium, flood light, heavy duty type.
3.35	SF64	1 x 400	Sodium, flood light, heavy duty type.
3.36	SF65	2 x 250	Sodium, flood light, heavy duty type.
3.37	SF66	2 x 400	Sodium, flood light, heavy duty type.
3.38	SP21	1 x 70	Sodium, post top lantern.



**TECHNICAL SPECIFICATION FOR
LIGHTING FIXTURES, LAMPS &
MISCELLANEOUS ITEMS**

SPECIFICATION NO. PE-SS-999-558-E006

VOLUME II

SECTION II

REVISION: 0

DATE: 08.09.2016

SHEET 37 OF 38

4.0 Tungsten Lamp Luminaires

- | | | | |
|------|------|---------|--|
| 4.1 | TW41 | 1 x 100 | Tungsten, well glass, vapour proof with vitreous enamelled reflector. |
| 4.2 | TW42 | 1 x 200 | Tungsten, well glass, vapour proof with vitreous enamelled reflector. |
| 4.3 | TW51 | 1 x 100 | Tungsten, well glass, dust proof with vitreous enamelled reflector. |
| 4.4 | TW52 | 1 x 200 | Tungsten, well glass, dust proof with vitreous enamelled reflector. |
| 4.5 | TW91 | 1 x 100 | Tungsten, well glass, flame proof with vitreous enamelled reflector. |
| 4.6 | TW92 | 1 x 200 | Tungsten, well glass, flame proof with vitreous enamelled reflector. |
| 4.7 | TW95 | 1 x 100 | Tungsten, well glass, increased safety (Div. 2) with vitreous enamelled reflector. |
| 4.8 | TW96 | 1 x 200 | Tungsten, well glass, increased safety (Div. 2) with vitreous enamelled reflector. |
| 4.9 | TB21 | 1 x 60 | Tungsten, bulk head, weather proof. |
| 4.10 | TB22 | 1 x 100 | Tungsten, bulk head, weather proof. |
| 4.11 | TB91 | 1 x 100 | Tungsten, bulk head, flame proof. |
| 4.12 | TB92 | 1 x 200 | Tungsten, bulk head, flame proof. |
| 4.13 | TP21 | 1 x 200 | Tungsten, post top lantern. |
| 4.14 | TE02 | 1 x 20 | Tungsten, portable emergency unit with rechargeable battery. |
| 4.15 | TE02 | 1 x 40 | Tungsten, portable emergency unit with rechargeable battery. |
| 4.16 | TX01 | 1 x 60 | Tungsten, dispersive vitreous enamelled reflector. |
| 4.17 | TX02 | 1 x 100 | Tungsten, dispersive vitreous enamelled reflector. |
| 4.18 | TX03 | 1 x 75 | Decorative recessed mounting luminaire suitable for comptalux lamp. |
| 4.19 | TX04 | 1 x 100 | Decorative recessed mounting luminaire suitable for comptalux lamp. |

1100883/2022/PS-PEM-EI



**TECHNICAL SPECIFICATION FOR
LIGHTING FIXTURES, LAMPS &
MISCELLANEOUS ITEMS**

SPECIFICATION NO. PE-SS-999-558-E006

VOLUME II

SECTION II

REVISION: 0

DATE: 08.09.2016

SHEET 38 OF 38

4.20 TX05 2 x 100 Double obstruction aviation light of cast Al. alloy with red glass.

5.0 Halogen

5.1 HF61 1 x 300 Halogen, flood light, drip proof.

5.2 HF62 1 x 500 Halogen, flood light, drip proof.

5.3 HF63 1 x 750 Halogen, flood light, drip proof.

5.4 HF64 1 x 1000 Halogen, flood light, drip proof.



VOLUME : II-F/2

SECTION-VI

TECHNICAL SPECIFICATION

ILLUMINATION SYSTEM





CONTENT

CLAUSE NO.	DESCRIPTION	PAGE
1.00.00	SCOPE OF SUPPLY	1
2.00.00	CODES AND STANDARDS	2
3.00.00	DESIGN CRITERIA	2
4.00.00	SPECIFIC REQUIREMENTS – SUPPLY	8
5.00.00	SPECIFIC REQUIREMENTS - SERVICES	16
6.00.00	TESTS	26
7.00.00	SPECIAL TOOLS & TACKLE	27
8.00.00	SPARES	27
9.00.00	DRAWINGS DATA & MANUALS	27

ATTACHMENTS

ANNEXURE-A	AVAILABLE POWER SUPPLY	29
ANNEXURE-B	AVERAGE LUX LEVEL OF DIFFERENT AREAS	30
ANNEXURE-C	TYPES OF FITTINGS/ FIXTURES AND OTHER AUXILIARIES	33
ANNEXURE-D	1100V LV POWER CABLE (XLPE TYPE)	40
ANNEXURE- E	CONTROL CABLES	41
ANNEXURE- F	RATINGS & REQUIREMENT OF LIGHTING TRANSFORMER	42





SECTION - VI

ILLUMINATION SYSTEM

1.00.00 SCOPE OF SUPPLY

1.01.00 The work involves timely procurement and transportation to site in properly packed condition of all equipment, materials and miscellaneous items required to complete the project.

1.02.00 The equipment and materials within the scope of supply shall include but not limited to:

- a) Lamp and LED type lighting fixtures and related LED accessories.

- d) Ceiling fans, receptacles, switches, switchboards, portable emergency lights, portable 24V supply module including handset as maintenance equipment etc.

- e) Cables, wires, splicing/termination/connection accessories including 4 way/3 way/2 way cable junction boxes with disconnecting devices on each way.

- f) Conduit and accessories, junction and pull boxes, terminal blocks.

- h) All fittings, supports, brackets, anchors, clamps and connections.

- i) Steel for field fabrication of supports and brackets.

1.03.00 Carrying out of detail engineering, including detail design calculations, preparation of lighting layouts showing location of fixtures, cable, wires conduit routing, indicating number and size of wires in each conduit and preparation of cable schedule and other related drawings as detailed in subsequent clauses

1.04.00 Preparation of "As built" drawings at the option of owner.

1.05.00 Special tools and tackle.

1.06.00 Spare parts

1.07.00 All relevant drawings, data and instruction manuals.





2.00.00 CODES AND STANDARDS

2.01.00 Major standards, which shall be followed, are listed below. Other applicable Indian standards even if not covered in the listed standard shall be followed.

- a) IS-1913
- b) IS-2148
- c) IS-2147
- d) IS-1944
- e) IS-3646
- f) IS-5572
- g) IS-6665
- h) National Electrical Code
- i) Indian Electricity Rules
- j) Indian Electricity Act.

3.00.00 DESIGN CRITERIA

3.01.00 Design Basis

3.01.01 The system provides lighting and electric power supply to Main Plant Boiler Turbine, Generator area along with balance of plant areas (viz. FGD etc.). In addition, it also provides lighting to selected areas during plant emergency conditions.

3.01.02 The system will be installed in an adverse industrial environment. Equipment in some areas will be subject to vibration, coal-dust, fly-ash, oil/water vapours as prevalent in a thermal generating plant.

3.01.03 The design shall be such as to provide minimum lighting levels as specified for different areas.

3.01.04 The Bidder shall carefully consider these lighting levels and layouts in making the offer and shall clearly indicate if any change is required to achieve the design lighting levels with the equipment offered.

3.01.05 The systems shall be suitable for operation on available power supply having characteristics as given in the annexure.

3.01.06 All fittings of control room / office shall be automated control with energy efficient type lighting fixture and lamps.





3.01.07 The main plant & auxiliary building and other BOP area shall generally be provided with

- ❖ Main lighting system for full illumination under normal power supply conditions and shall operate from 415V/240V AC power supply tapped from respective MLDB/lighting panels.
- ❖ Emergency lighting system for reduced illumination operated by DG supply feeders during failure of main power supply. It shall cover 20% of fixtures in the building and associated area.
- ❖ Minimum emergency lighting system for reduced illumination during failure of main power supply with the help of 220V DC batteries/supply feeders. This is applicable for Coal Handling Plant also. [REDACTED]

3.01.08 Various lighting panel shall be fed directly from nearest Main Lighting Distribution board. All MLDBs shall have duplicate incomers and a bus-section. [REDACTED]

3.02.00 System Concept

The lighting system shall comprise following sub-systems:

3.02.01 Normal A.C. Lighting

- a) This will be provided by A.C. lighting fixtures distributed throughout the plant area. These lights will be ON as long as the station / normal A.C. supply is available.
- b) A.C. lighting fixtures will be fed from respective area lighting panels (LP), which in turn will be connected to nearest main lighting distribution board (MLDB). The lighting panels shall be provided with at least 20% spare outlets.

3.02.02 Emergency A.C. Lighting

- a) On failure of normal A.C. Supply, emergency A.C. lighting will be provided in selected areas for safe movements and operation of important auxiliaries.
- b) Emergency A.C. lighting fixtures will be fed from respective area emergency lighting panels (ELP) either through cable junction box or direct, which in turn will be connected to emergency AC Main Lighting Distribution Board (ACEMLDB). It should be fed from Emergency MCC





and same like MLDB. The emergency lighting panels shall be provided with at least 20% spare outlets.

These lights will be kept "ON" from normal power supply source. But failure of normal power supply these will be fed from DG through 415V Emergency MCC. This change over of power supply will be done by automatic switching.

- c) A.C. emergency lighting fixture [such as Power house(all area), ESP and ESP building, boiler(all areas and floors), switchyard, CW pump house control and switchgear room, transformer yard, auxiliary building etc.] will account for 20% of the total lighting fixtures except in main control room and DG room wherein 30% A.C. Emergency lighting shall be provided.

3.02.03 Emergency D.C. Lighting

- a) This will be provided by D.C. lighting fixtures located strategically in critical operating areas and emergency exits. Emergency D.C. lighting fixtures will be fed from respective area DC lighting panels (DCLP) either through cable junction box or direct, which in turn will be connected to DC Emergency Lighting Distribution Board (DCELDB).



- a) This will be provided by emergency A.C / D.C. lighting fixtures located strategically in critical operating areas and emergency exits. Emergency DC lighting will be catered by DC Emergency Lighting Distribution (DCELDB) boards. These DCELDBs will feed the DC emergency lighting fixtures directly and through a numbers of DC emergency lighting panels (DCLP) located suitably in respective areas.
- b) The DC Emergency Lighting Distribution Boards will be fed from two power sources, namely -
- i) Main Lighting Distribution Board (MLDB).
 - ii) 220V DC distribution boards (DCDB).

These lights will be ON all the time - normally from station A.C. supply, but on its failure from respective DCDB through automatic switching.

3.02.04 Street/Area Lighting

Time switch will be used for controlling area/outdoor/coal yard/marshalling yard lights with provision for manual override and also have the provision of proven Energy Saving Systems.

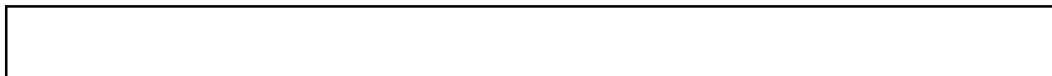



Illumination shall be provided from cable/pipe bridge running parallel and closed to the road instead of providing conventional lighting poles wherever possible.

3.02.05 Remote Emergency Lighting

This will be provided in isolated building/area/mobile equipment viz. stacker-reclaimer [where D.C. supply is not available] by self-contained battery/automatic charger/inverter/flood light units. These portable emergency light units will be energized automatically on loss of normal A.C. supply.

3.02.06 Portable 24V supply module

24V power supply module complete shall be provided for 24V as maintenance lighting.

3.02.07 Control Philosophy in Control Room / Offices with false ceiling only

Automatic lighting control solutions shall be provided to reduce energy usage by eliminating over-illumination. These solutions provide centralized control of lighting, allowing easy implementation of scheduling, occupancy control, daylight harvesting etc.

Occupancy sensors to allow operation for whenever someone is within the area being scanned can control lighting. When motion can no longer be detected, the lights shut off. Passive infrared sensors react to changes in heat, such as the pattern created by a moving person. The control must have an unobstructed view of the building area being scanned. Ultrasonic sensors transmit sound above the range of human hearing and monitor the time it takes for the sound waves to return. A break in the pattern caused by any motion in the area triggers the control. Ultrasonic sensors can see around obstructions and are best for areas with cabinets and shelving, restrooms, and open areas requiring 360-degree coverage. Occupancy sensors utilizing both passive infrared and ultrasonic technology shall be used to control fixtures and lamps.

3.03.00 Ratings & Requirements

3.03.01 All equipment and accessories shall be designed for continuous operation under site conditions without exceeding permissible temperature rise as stipulated in relevant standards.

3.03.02 Switch, fuses, MCCB, miniature circuit breakers (MCB), busbar shall be fully rated for short circuit level at the point of application. MCB shall have back-up HRC fuse if its rating is less than the available short circuit current.

3.03.03 All equipment and accessories shall have proper enclosure to suit the site conditions. In hazardous areas all equipment and accessories shall have flame-proof enclosure.





3.03.04 Wiring from lighting panels to fixtures and from lighting panels to 5/15A receptacles shall be carried out by PVC insulated wires through G.I. Conduits.

3.03.05 Heavy duty XLPE FRLSH power cables as per IS 7098 will be used for connections as follows:

- a) From Main Lighting Distribution Board (MLDB) to Area Lighting Panel.
- b) From Emergency Main Lighting Distribution Board (ACEMLDB) to Emergency Lighting Panels (ELP).
- c) From DC Emergency Lighting Distribution Board (DCELDB) to DC Lighting Panels (DCLP).
- d) From Street/Area lighting panel to street light poles / Flood Light Tower.
- e) From welding DB to receptacles of 63A and above.

In main power house, Boiler, transformer yard, CWPH, ESP area and other areas like AHP, CHP, FGD etc. the 63A power receptacle shall be fed from separate Welding DBs. Each Welding DB shall be fed through 1:1, 100kVA isolating transformer. The transformer shall preferably be located inside the Welding DB panel itself. Maximum 12 nos. outgoing feeders shall be provided from each Welding DB.

Minimum Number of welding DBs to be provided:

- | | |
|---------------------|----------|
| a) Main Power House | : 2 nos. |
| b) AHP area | : 1 no. |
| c) CHP area | : 1 no. |
| d) Boiler area | : 2 no. |
| e) ESP area | : 1 no. |
| f) CW PH area | : 1 no. |
| g) FGD area | : 1 no. |

3.03.06 Inside Switchboards wiring shall be carried out with 1100V PVC stranded copper wire.

3.03.07 Distinctive earth terminal shall be provided either inside or outside of each equipment included under the scope of the bidder.

3.04.00 Method of Calculation

3.04.01 Standard Lumen method shall be adopted for interior & exterior lighting in order to calculate the number of lighting fixtures for obtaining the desired average level of illumination.

3.04.02 The coefficient of utilization shall be considered to take care of Lumen loss due to:

- a) Effect of room dimensions.
- b) Absorption of light in luminaires.





- c) Absorption of light at various room surfaces i.e ceiling wall etc.
- d) Floor cavity, ceiling cavity.
- e) Mounting height.

3.04.03 Moreover a maintenance factor shall also be considered to account for the fall of illumination due to aging, pollution like dust deposit etc. Maintenance factors to be considered for various areas shall be as follows:

Area	Maintenance factor
Control Room	0.75
Switchgear/MCC Room	0.65
General indoor area	0.60
Dusty Area	0.55
Light loss Factor	

It is recommended that in interiors with fairly clean atmosphere, for example, offices, air conditioned factory interiors etc, a light loss factor of 0.8, in interiors which are prone to accumulate dust faster, for example, most in industrial interior an LLF of 0.7 and in high dirt prone interiors an LLF of 0.6 may be adopted for calculating the no. of luminaires to be installed for a particular service illuminance.

3.04.04 To achieve the recommended luminance relationship, it is necessary to select the reflectance of all finishes of the room surfaces. The recommended reflectance values for industrial interiors and equipment are given bellow for bidder's guide lines:

Reflectance values

(For station / other BOP area except CHP)

<u>Surface</u>	<u>Reflectance Percentage</u>
Ceiling	80-90
Wall	40-60
Desk and Bench tops, machines And equipment	25-45
Floor	not less than 20

CHP Requirement:-

For Dusty area such as conveyor galleries, TPs, crusher house etc.:

<u>Surface</u>	<u>Reflectance Percentage</u>
----------------	-------------------------------





Ceiling	50
Wall	30
Floor	10

- 3.04.05 Lux level to be considered for various areas are given in Annexure-B.
- 3.04.06 Voltage drop at the fixture from the MLDB bus shall not exceed 3%.
- 3.04.07 Circuit loading of each lighting Panel shall be done as per relevant codes/Indian Standards in such a way that almost balanced loading in all the phases i.e. R, Y & B is achieved.
- 3.04.08 At least two (2) sub circuits shall be used for illumination of a particular area.

- 3.04.10 The working plane shall be considered at 0.85 m from the floor level.
- 3.04.11 Calculation can be done through proven software program by maintaining uniformity ratio as per relevant IS.

4.00.00 SPECIFIC REQUIREMENTS - SUPPLY

- 4.01.00 Equipment and Material
- 4.01.01 Equipment and material shall comply with description, rating, type and size as detailed in this specification, drawings and annexures.
- 4.01.02 Equipment and materials furnished shall be complete and operative in all details.
- 4.01.03 All accessories, control devices, internal wiring, fittings, supports, hangers, anchor bolts etc. which form part of the equipment or which are necessary for safe and satisfactory installation and operation of the equipment shall be furnished.
- 4.01.04 All parts shall be made accurately to standard gauges so as to facilitate replacement and repair. All corresponding parts of similar equipment shall be interchangeable.
- 4.02.00 Lighting Fixtures
- 4.02.01 Lighting fixtures shall be designed for minimum glare. The surface finish shall be smooth, unobtrusive, scratch resistant and no bright spots are produced either by direct light source or by reflection. Fixture shall conform to latest IS / IEC and its latest amendment
- 4.02.02 All lighting fixtures shall be complete with LED (energy efficient type) for lighting. LED lamp fixtures shall be complete with all necessary wiring such as control gear & its accessories ignitor, power factor improvement capacitors (if required) etc. These shall be mounted in the fitting assembly only. The Contractor shall indicate starting time of these lamps to attain full light output. Curves for starting characteristics with varying supply voltage





etc. are to be furnished by the Contractor.

- 4.02.03 Flood lighting shall have suitable base plate/frame for mounting on structural steel member.
- 4.02.04 Fixture shall be suitable for 20 mm conduit entry and 16 SWG G.I. earth wire connection.
- 4.02.05 High bay fixtures shall have provision for vibration damper to ensure rated lamp life. Cost of each damper shall be separately indicated.
- 4.02.06 Fixtures shall be fully wired up to respective terminal blocks, suitable for loop in and loop out connection of PVC stranded wires of following sizes:
- a) Lighting fixture : 2.5 mm² Copper - Two (2) Numbers
 - b) Flood Light fixture : 2x2.5 mm² Copper - Two (2) Numbers
- 4.02.07 Reflector shall be of sheet steel or aluminium, minimum 20 SWG thick, securely fixed by fastening device of captive type.
- 4.02.08 Lamp holders
- Lamp holders shall be for LED lamp.. Holders shall be designed and manufactured in accordance with relevant standard to give long and satisfactory service.
- 4.02.09 Capacitors
- Capacitors shall have a constant value of capacitance and shall be connected across the supply of individual lamp circuits. Capacitors shall be suitable for operation at the supply voltage as specified and shall have a value of capacitance so as to correct the power factors of its corresponding lamp circuit. Capacitors shall be hermetically sealed in a metal enclosure.
- 4.02.10 Ballasts (if required)
- Ballasts shall be designed, manufactured and supplied in accordance with latest edition of IS and function satisfactorily under site condition specified. The ballasts shall be designed to have a long service life. The power loss in ballasts (if required) for LED lamps shall not be more than the specified watts as per relevant standard.
- Ballasts shall be mounted using self-locking, anti-vibration fixing and shall be easy to remove without dismantling the fixtures. They shall be totally enclosed units.
- The ballasts shall be of the inductive, heavy duty type, filled with thermosetting, insulating, moisture repellent polyester compound filled under pressure or vacuum. The ballast wiring shall be of copper wire. Ballasts shall be designed for maximum winding temperature rise of 55^oC under rated conditions. They shall be free from hum. Ballasts for LED lamps shall be provided with suitable tapping to set the voltage within the range specified. End connections and taps shall be brought out in a suitable terminal block, rigidly fixed to the ballast enclosure. Separate ballasts for each lamp shall be





provided in case of multi-lamp fixtures.

4.03.00 Lamps

The LED lamps to be supplied shall conform to IS 9974 or latest edition. LED lamps shall be suitable for use in any position. Restrictions, if any, shall be clearly stated. The lamps shall be capable of withstanding small vibrations without breakage of connections at lead-in wires and filament electrodes.

The Bidder shall furnish typical wiring diagrams for all fittings including all accessories. The diagrams shall include technical details of accessories i.e. ignitors, ballasts, capacitors etc.

4.05.00 Lighting Panel

4.05.01 Lighting panels shall be metal-enclosed, cabinet type, fabricated from CRCA sheet steel minimum 2 mm thick, suitable for either wall/column mounting on brackets or floor mounting on channel sills.



4.05.03 Lighting Panels shall be so constructed as to permit free access to the terminal connections and easy replacement of parts. Front access doors shall have padlocking arrangements.

4.05.04 Lighting panels shall have provision of cable entry from top and bottom, as required, with removable gland plates. Necessary double compression type brass cable glands, tinned copper/Aluminium cable lugs are to be furnished.

4.05.05 Two ground pads with M10 G.I. bolts and nuts shall be provided on each Lighting Panel for connection to ground conductor.

4.05.06 Each Lighting Panel shall be complete with designation and caution notice plates fixed on front cover and a circuit directory plate fixed on inside of the front cover. Circuit directory plate shall contain details of the points to be controlled by each circuit including the location of the point controlled, rating of the protective units and loading of each circuit.

The plates shall be of anodized aluminium with inscriptions indelibly etched on it.

4.05.07 Bus bar shall be electrolytic grade hard drawn aluminium, colour coded for easy identification and designed for a maximum temperature of 85°C. Minimum size shall be 25 x 6 mm.

4.05.08 Incoming and outgoing circuits shall be terminated in suitable terminal blocks.

4.06.00 Panel Equipment





- 4.06.02 Panel access door shall be interlocked with incoming MCCB such that the door can be opened only when the MCCB is in OFF position. Means shall be provided to defeat this interlock.
- 4.06.03 All MCCB shall be single throw, air break, heavy duty type having quick-make quick-break contacts. Contactors shall be air break electromagnetic type. Push buttons shall be push to actuate type.
- 4.06.04 MCB shall be suitable for manual closing and opening and also automatic trip on overload and short circuit.
- 4.06.05 Time switch in street lighting panels shall be clock switch type with ON-OFF time setting facility, which shall ensure respective ON-OFF operation in every 24 Hours cycle. Voltmeter/Ammeter shall be of accuracy class 2.0 or better as per IS: 1248. Voltmeter/Ammeter selector switch shall be of reputed make.
- 4.07.00 Receptacle
- 4.07.01 Receptacles shall be heavy duty, complete with individual plug and switch as detailed in the annexure. For Residential building, Electrical room, Pump room, Control Room 16/6 Amp receptacles shall be considered.
- 4.07.02 The conduit box of the receptacle shall be provided with earthing screws with washer and nuts welded on the surface for grounding with 16 SWG G.I. wire. Arrangement shall be provided inside the conduit box for grounding of third pin.
- 4.07.03 Shrouded type plug shall be provided with corresponding matching arrangement at sockets to prevent accidental contact with finger during plug insertion.
- 4.07.04 63 Ampere three phase four pin receptacle shall be provided at each major plant maintenance area.
- 4.08.00 Fans & Regulators
- 4.08.01 The fans shall have three well balanced metallic blades, and shall be reasonably free from noise. Pedestal fans shall also be provided as per requirement.
- 4.08.02 Fan motor shall be totally enclosed type with copper winding and class E insulation.
- 4.08.03 Regulator shall have minimum five steps in modular size. Electronic regulator with smooth control is to be provided.
- 4.09.00 Switch & Switch Board
- 4.09.01 All switch boards/boxes shall be of bent steel construction, fabricated of 14 SWG M.S. sheet with 6 mm thick colour matching FRP/ Non- Hygroscopic Synthetic cover with brass fixing screws.
- 4.09.02 Switch boards/boxes located in control room and office areas shall be flush mounted type on brick wall with only the switch knob projecting outside.





- 4.09.03 Switch boards/boxes shall have conduit knock outs on the sides. Adequate provision shall be made for ventilation of these boxes.
- 4.09.04 Flush type receptacles where provided shall be so located that only the plug projects outside.
- 4.09.05 Switches shall have quick-make and quick-break mechanism operated by a suitable external handle complete with position indicator.
- 4.10.00 Lighting Poles & Flood Light Tower

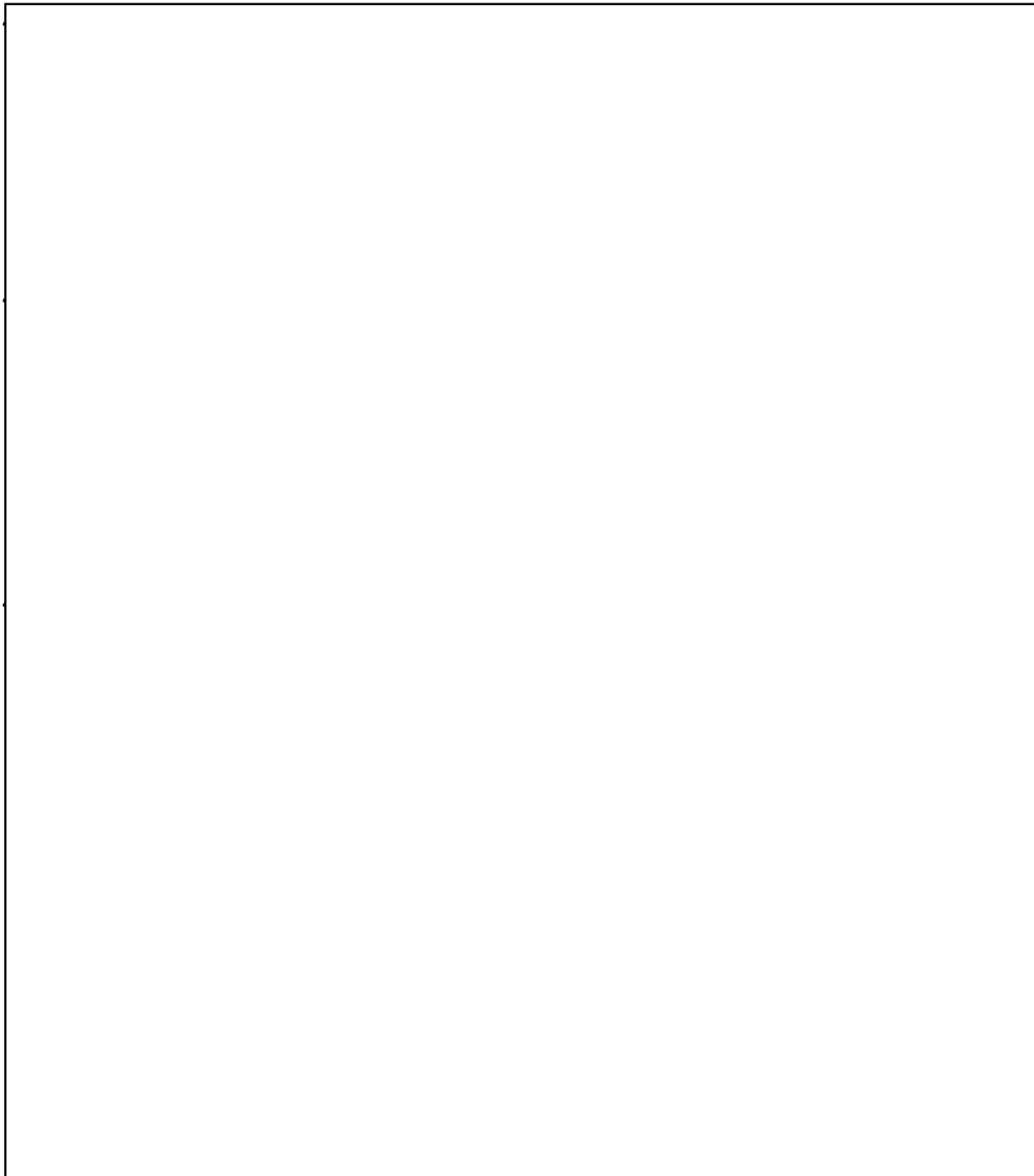

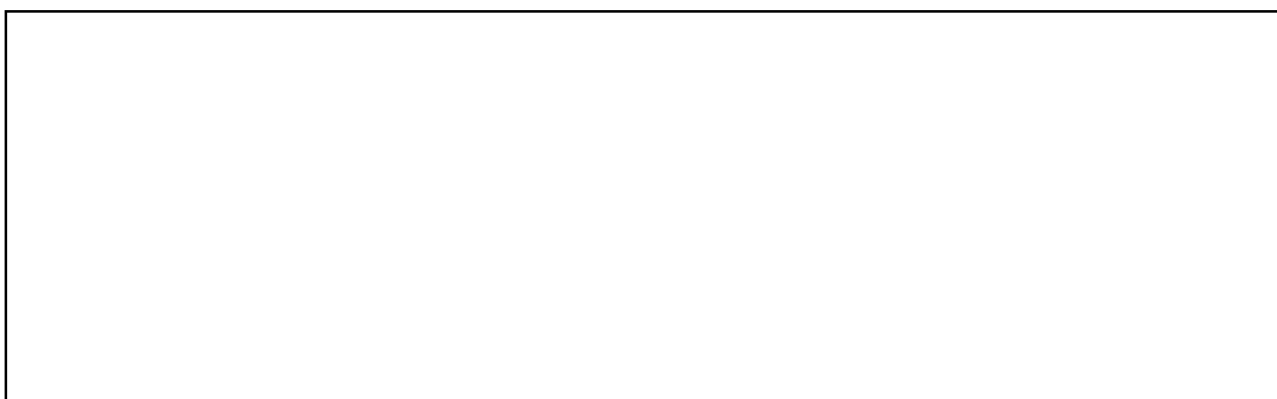
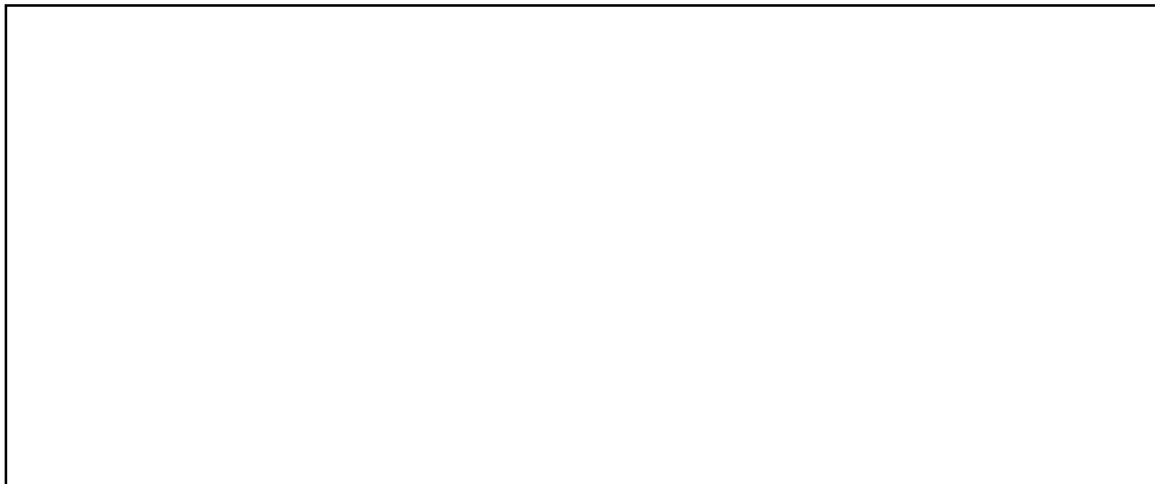

- 4.12.00 Special Requirement
- 4.12.01 All outdoor illumination fixtures, unless it is fed from photo cell/time switch controlled lighting panel, has to be provided with outdoor type local switches.
- 4.12.02 In all the air filtration units and air handling units, one marine type lamp (of 100 Watt approx.) shall be provided and the wiring & fixing of the same has to be done by the Bidder.
- 4.13.00 Lighting Cables & Wires
- 4.13.01 Lighting Cable shall be heavy duty, 1100 Volt grade, multicore stranded copper conductor, XLPE insulated, extruded PVC inner sheath, single round G.I. wire armoured and overall PVC sheathed with FRLSH conforming to IS 1554.
- 4.13.02 Lighting wires shall be 1100 Volt grade, PVC insulated, stranded conductor, single core cable conforming to IS 694, colour coded as below :
- | | | | | | |
|--------|-----|---------|-------|-----|----------|
| RED | for | R-Phase | BLACK | for | Neutral |
| YELLOW | for | Y-Phase | WHITE | for | +Ve D.C. |
| BLUE | for | B-Phase | GREY | for | -Ve D.C. |





- 4.14.00 Conduits and Accessories
- 4.14.01 Conduits shall be rigid steel, hot-dip galvanised, furnished in standard length of 3 metres, threaded at both ends.
- 4.14.02 Thickness of conduits up to and including 25 mm dia shall be of 16 SWG and conduits above 25 mm shall be of 14 SWG. Minimum size of conduits shall be 20 mm.
- 4.14.03 Each piece of conduit shall be straight, free from blister and other defects and covered with capped bushings at both ends.
- 4.14.04 Flexible conduits shall be made with bright, cold rolled annealed and electro-galvanised mild steel strips and coated with PVC.
- 4.15.00 Junction Box
- 4.15.01 Junction boxes shall be of 16 SWG sheet steel hot-dip galvanised, dust and damp proof, generally conforming to IP-55.
- 4.15.02 Junction boxes shall be complete with gasketed inspection cover, conduit knock out/threaded hub and terminal blocks.
- 4.15.03 Junction box for outdoor use shall be weatherproof IPW-55. For hazardous location junction box shall be flame-proof type suitable for a particular zone / gas group in compliance with IS: 2148 / IS: 13346 and shall have certification from CIMFR, Dhanbad.
- 4.15.04 Junction boxes shall have following indelible markings:
- Circuit nos. on top
- Circuit nos. with ferrules (inside) as per drawing
- DANGER sign in case of 415V circuit
- 4.16.00 Terminals



- 4.16.01 Multi way terminal blocks of approved type, complete with screws, nuts, washers and marking strips shall be furnished for connection of incoming/outgoing wires.
- 4.16.02 Each terminal shall be suitable for connection up to 2 nos. 10 Sq.mm stranded aluminium conductors without any damage to the conductor or looseness of connectors.



4.18.00 24 V Supply Module

Each 24V A.C. supply module shall have one (1) no air cooled two winding, 500VA, 1-phase, 50HZ, 240/24V transformer with 6A (240V side) and 16A (24V side) HRC fuse and necessary 240V and 24V terminals for incoming and outgoing connections. The 240V terminals of 24V AC supply module shall be fed from respective lighting panels. A group of 6A, 24V AC receptacles located near Boiler access doors and condenser area shall be wired up from 24V side of each 24V A.C. supply module.

The 24V A.C. supply modules shall be sheet steel enclosed with louvers and shall be suitable for outdoor use. The 24V A.C. supply modules shall be suitable for wall/steel structure/column mounting. Switches shall be mounted at the front on sheet steel enclosure.

- 4.18.01 Portable 24 V AC supply modules having sheet steel enclosure with louvers as per above shall be supplied. 24V halogen automobiles lamps with reflector along with 1100 V, twin core PVC sheathed, 2.5 mm² stranded copper wire of 20 m lengths as handset.

4.19.00 Indication Lamp

Lamps shall be clustered of LED type. LED lamp shall be made in accordance with InP Technology (Aluminium Indium Gallium Phosphide Technology). The body shall be made of Poly Carbonate Unbreakable Lens. LED shall be protected by inbuilt fuse with surge suppressor or leakage voltage glow protection. LED circuit shall be PCB mounted. Intensity shall be greater than 200 mcd. All Push Button lamps shall be as per LED indicating lamp.

4.20.00 Contactors

- 4.20.01 Contactors shall be three pole, air break type, with non-bouncing silver/silver alloy contacts. Contactor duty shall be class III - category AC3 for unidirectional drives and AC4 for bi-directional and inching drives/class I - category DC2.
- 4.20.02 Each contactor shall be provided with minimum two (2) N/O and two (2) N/C auxiliary contacts rated 10 A at operating voltage. The exact requirement of contacts shall be decided by the Vendors taking into account the scheme requirements and spares.





- 4.20.03 Contactor starters shall comply with the requirements of IS-8544 (Part - 1) in respect of co-ordination of the characteristics of contactor, overload relay, and fuse. The type of co-ordination shall be Type - C as per IS-8544.
- 4.21.00 Moulded Case Circuit Breaker (MCCB)
- 4.21.01 MCCB shall be heavy duty, triple pole, load break-fault-make type conform to the duty as required. MCCB shall be provided with a common trip bar, so as to ensure opening of all phases even when fault occurs in only one phase.
- 4.21.02 MCCB shall have positive indication in ON and OFF position with indication on each Module.
- 4.21.03 The MCCB should be housed in a heat resistant moulded insulated housing Overload and Magnetic release of MCCB shall be suitable for setting at site. The Short Circuit release shall be of minimum of 12x In.
- 4.21.04 For Fuel Oil / hazardous area, one(1) no. 63Amp MCB shall be provided within a Flame-proof enclosure .The enclosure shall be Flame-proof as per the stipulations of relevant standard. It shall have a degree of protection of IPW-55. The enclosure front access door shall be interlocked with the MCB. It shall have grounding facility on opposite sides complete with designation and caution notice plates fixed on the front cover. It shall meet the requirement of IS 5571 & IS – 5572.The MCB enclosure shall suitable for entry of 4/Cx16 sq.mm XLPE Copper cable. The total unit shall have a valid certification for using in the specified zone from statuory authority preferably of CMRI and/or CE Ex II 2 G EEx-D IIB T4/T5/T6; CE Ex II2 2(1) G EEx-d (ia) IIB T5/T6; CE Ex II2 (1) GD EEx-d (ia)IIB T5/T6 or similar.
- 4.22.00 Nameplate
- Nameplates shall be furnished for identification of devices and circuits. All switches, controls and indications shall be permanently and legibly marked in English as to clearly indicate their functions.
- All lighting fixtures, receptacles, fans, junction boxes etc. shall be properly marked up indelibly with corresponding circuit numbers.
- 4.23.00 Samples
- Owner reserves the right to call for samples if considered necessary and the same shall be submitted by the Bidder free and without any obligation.
- 5.00.00 SPECIFIC REQUIREMENTS - SERVICES**
- 5.01.00 Responsibility of Erection
- 5.01.01 The Bidder shall be fully and finally responsible for proper erection, safe and satisfactory operation of plant and equipment under his scope of work to the entire satisfaction of the Engineer.



- 5.01.02 The work shall be executed in accordance with the directions, instructions, drawings and specifications which shall be supplied to the Bidder by the Engineer time to time.
- 5.01.03 If in the opinion of the Bidder any work is insufficiently specified or require modification, the Bidder shall refer the same in writing to the Engineer and obtain his instruction/ approval before proceeding with the work.
- 5.01.04 If the Bidder fails to refer such instances any excuse for the faulty erection, poor workmanship or delay in completion shall not be entertained.
- 5.01.05 Equipment and material which are wrongly installed shall be removed and reinstalled to comply with the design requirement at the Bidder's expense, to the satisfaction of the Engineer.
- 5.02.00 Supervision
- 5.02.01 The Engineer shall have the overall responsibility for co-ordination of Bidder's work and his direction shall be final.
- 5.02.02 Such direction and supervision however shall not relieve the Bidder of his responsibility of correctness and quality of workmanship and of other obligation under the contract.
- 5.03.00 Drawings
- 5.03.01 Drawings and schedules enclosed with this specification are for general guidance of the Bidder to asses the type and volume of the work involved.
- 5.03.02 These drawings and schedules will be revised to suit the actual requirement in related system. Additional drawings and schedules will also be furnished to Bidder if/when necessary. Final drawings and schedules will be furnished to the Bidder time to time as detailed designs are developed.
- 5.03.03 Such supervision, correction and addition to drawings and schedule shall not be considered to change the scope of work.
- 5.03.04 The Bidder shall mark in red on one (1) set of drawings all deviations/ alterations, not shown on drawing but carried out at field. After completion of work the Bidder shall furnish a set of marked up prints of "As built" drawings to the Owner.
- 5.04.00 Methods and Workmanship
- 5.04.01 All work shall be installed in a first class, neat workmanlike manner by machines/ electricians skilled in the trade involved.
- 5.04.02 The erection work shall be supervised by competent supervisors holding relevant supervisory license from the Government.
- 5.04.03 All details on installation shall be electrically and mechanically correct.





- 5.04.04 The installation shall be carried out in such a manner as to preserve access to other equipment installed.
- 5.05.00 Protection of work
- 5.05.01 The Bidder shall effectively protect his work, equipment and materials under his custody from theft damage or tampering.
- 5.05.02 Finished work where required shall be suitably covered to keep it clean and free from defacement of injury.
- 5.05.03 For protection of his work Bidder shall provide fencing and lighting arrangement, connect up space heaters and provide heating arrangement as necessary and directed by Engineer.
- 5.05.04 Bidder shall be held responsible for any loss or damage to equipment and material issued to him until the same is taken over by the Owner according to contract.
- 5.06.00 Safety Measure
- 5.06.01 All safety codes and rules as applicable to work shall be followed without exception.
- 5.06.02 all safety appliance and protective devices including belt, hand gloves, aprons, helmets, shields, goggles etc. shall be provided by the Bidder for his personnel.
- 5.06.03 The Bidder shall provide guards and prominently display caution notices if access to any equipment/area is considered unsafe and hazardous.
- 5.07.00 Co-operation
- 5.07.01 The Bidder shall at all time work in close coordination with the Owner's supervising personnel and afford them every facility to become familiar with erection and maintenance of the equipment.
- 5.07.02 The Bidder shall arrange his schedule of work and method of operation to minimize inconvenience to other Bidders working on the project.
- 5.07.03 In case of any difference between Bidders, the decision of the Engineer shall be final and binding of all parties concerned.
- 5.08.00 Erection program and Progress
- 5.08.01 The Bidder shall submit at such times and in such forms as maybe requested by the Engineer, schedule showing the program and the order in which the Bidder process to carry out the work with dates and estimated completion time for various parts of the work.
- 5.08.02 Such schedules shall be approved by the Engineer prior to starting the erection. The Bidder shall adhere to this approved program for all practical purpose. If for any reason the work is held up, the Bidder shall bring it to the attention of the Engineer in writing without any delay.





- 5.08.03 During the progress of work the Bidder shall submit monthly progress report and such other reports on erection work and organization as the Engineer may direct.
- 5.08.04 If in the of the Engineer the progress of erection work by the Bidder at any stage needs expediting so as to ensure completion of work within stipulated time, the Engineer shall have the right to instruct the Bidder to increase Bidder's manpower in appropriate categories and/or the working hours per day and/or erection tools and tackles and the Bidder shall comply with such instruction forthwith.
- 5.09.00 Consumables and Hardware
- 5.09.01 The Bidder shall furnish all erection materials, hardware and consumables required for the complete installation.
- 5.09.02 The materials shall include but shall not be limited to the following:
- a) Consumables : Welding rods & gas, oil and grease, cleaning fluids, paints, electrical tape, soldering materials etc.
 - b) Hardware : Bolts, nuts, washers, screws, brackets, supports, clamps, hangers, saddles, cleats, sills, shims etc.
 - c) Materials : Junction boxes, terminal blocks, connectors, ferrules, lugs, brass glands, rigid/flexible conduits, cables, ground wires etc.
- 5.09.03 Supply of cement, sand, stone etc. required for the execution of the contract shall be the responsibility of the Bidder.
- 5.10.00 Erection Tools & Tackle
- 5.10.01 The Bidder shall provide all tools, tackles, implements, scaffoldings, ladders etc which are required for handling and erection of the equipment and materials.
- 5.11.00 Testing Equipment
- 5.11.01 The Bidder will provide such checking and testing equipment as test lamp, buzzer, 500-volt meggar, earth meggar, lux-meter etc. with other testing equipment as required.
- 5.12.00 Taking Delivery
- 5.12.01 The Bidder shall take delivery of materials & brought to the erection site, stored or erected as necessary.
- 5.12.03 The Bidder shall submit a detailed account of materials after completion of each work.
- 5.13.00 Opening of Case





- 5.13.01 All packing cases and packages shall be opened in presence of Engineer or his authorized representatives.
- 5.13.02 Packing cases shall be opened carefully to avoid damage to timber. Nails and strips shall be collected separately in boxes and not to be thrown away in random.
- 5.13.03 All packing materials, timbers, nails and strips shall become property of Owner and shall be delivered to the Owner or disposed of as directed by the Engineer.
- 5.14.00 Checking and Cleaning of Part
- 5.14.01 All lighting fixtures, lamps, accessories and materials shall be carefully inspected and checked with packing list and identified with the erection drawings.
- 5.14.02 Any discrepancy shall be reported forthwith in writing to the Engineer and repair carried out as described herein-before.
- 5.14.03 all parts shall be thoroughly cleaned, all rust removed and surface polished as required.
- 5.14.04 Cleaned and polished parts shall be coated with anticorrosive paints where necessary and stored with care, ready for erection.
- 5.15.00 Installation - General
- 5.15.01 Installation work shall be carried out in accordance with good engineering practices and also manufacturer's instructions/ recommendations where the same are available.
- 5.15.02 Equipment shall be installed in a neat workmanlike manner so that it is level, plumb, square and properly aligned and oriented.
- 5.16.00 Lighting Fixtures
- 5.16.01 In case of closed ceiling industrial premises generally a continuous mounting of fittings is to be preferred, for tubular fluorescent lamps fittings, to an arrangement of reflectors at intervals to provide a more restful view.
- 5.16.02 In turbine hall, fixtures shall be mounted to maintain sufficient clearance from the overhead travelling crane trolley.
- 5.16.03 In boiler galleries, mounting height of fixtures shall be about 2500 mm from platforms except shown otherwise.

Bracket for fixture mounting shall be fabricated at site from 40 mm conduits with a reducing socket to suit the fixtures and clamped on to the handrails. The fixing shall be strong enough to withstand vibration and high wind velocity.

If a roof over platform is available, the fixture can be pendant mounted.





- 5.16.04 Floodlights shall be mounted on steel base facing the tentative direction shown on drawings. Fixing holes shall be provided with slot to turn the fixture about 5 Deg on both sides. Bolts shall be finally tightened with spring washer.
- The Bidder shall supply and install the steel base for fixing the flood light on the flood light towers.
- Terminal connection to the floodlight shall be made through PVC coated flexible metallic conduits.
- 5.16.05 Fixtures shall be mounted on sub-station structures with suitable clamps. No cutting or drilling of sub-station structures is permitted. It is preferable to provide separate structures in Switchyard and Substation.
- 5.16.06 The fixtures after erection shall be marked up indelibly with corresponding circuit number for easy identification of lamp circuit.
- 5.17.00 Receptacles
- Receptacles shall be installed at locations not more than 50 meter or as per approved drawings.
- 5.18.00 Lighting Panel
- 5.18.01 Lighting panels shall be erected at the convenient locations with cable junction boxes as per approved drawing.
- 5.19.00 Street Lighting Poles
- Erection of street light poles, flood lighting towers/poles/high masts shall be at the convenient locations with cable lying as per approved drawing.
- 5.20.00 Conduit System
- 5.20.01 In case of unarmoured cable, all conduits shall originate from the respective lighting panel and terminate in lighting fixtures, receptacles etc.
- 5.20.02 Exposed conduits shall be run in straight lines parallel to building columns, beams and walls as far as practicable. Unnecessary bends and crossings shall be avoided to present a neat appearance.
- 5.20.03 Conduit supports shall be provided at an interval of 750 mm for horizontal runs and 1000 mm for vertical runs.
- 5.20.04 Conduits shall be clamped on to approved type spacer plates or brackets by saddles or U-bolts. The spacer plates or brackets in turn, shall be fixed to the building steel by welding and to concrete or brick work by grouting as shown on drawings.
- Wooden plug inserted in the masonry or concrete for conduit support is not acceptable.





- 5.20.05 Embedded conduits shall be securely fixed in position to preclude any movement. In fixing embedded conduit, if welding or brazing is used, extreme care should be taken to avoid any injury to the inner surface of the conduit.
- 5.20.06 Spacing of embedded conduits shall be such as to permit flow of concrete between them and in no case shall be less than 40 mm.
- 5.20.07 Where conduits are run on cable trays they shall be clamped to supporting steel at an interval of 600 mm.
- 5.20.08 For directly embedding in soil, the conduits shall be coated with an asphalt - base compound. Concrete pier or anchor shall be provided where necessary to support the conduit rigidly and to hold it in place.
- 5.20.09 Conduits shall be installed in such a way as to ensure against trouble from trapped condensation.
- 5.20.10 Running threads shall be avoided as far as practicable. Where it is unavoidable, check nuts shall be used.
- 5.20.11 Conduits shall be kept, wherever possible, at least 300 mm away from hot pipes, heating device etc. when it is evident that such proximity may impair the service life of cables.
- 5.20.12 Slip joints shall be provided when conduits cross structural expansion joints or where long run of exposed conduits are installed, so that temperature change will cause no distortion due to expansion or contraction of conduit run.
- 5.20.13 For long run, junction/pull boxes shall be provided at suitable intervals to facilitate wiring.
- 5.20.14 Conduits shall be securely fastened to junction box or cabinets, each with a locknut and insulated bushing inside the box and locknut outside.
- 5.20.15 Conduit lengths shall be joined by screwed couplers. Couplers shall be clearly cut.
- 5.20.16 Conduit joints and connections shall be made thoroughly water-tight and rust-proof by application of a thread compound which will not insulate the joints.
- White lead is suitable for application on embedded conduit and red lead for exposed conduit.
- 5.20.17 The Battery Room installation shall be made with acid fume proof conduits.
- 5.20.18 Field bends shall have a minimum radius of four (4) times the conduit diameter. All bends shall be free of kinks, indentations or flattened surfaces. Heat shall not be applied in making any conduit bend.
- 5.20.19 The entire metallic conduit system, whether embedded or exposed, shall be electrically continuous and thoroughly grounded.





- 5.20.20 Lighting fixture shall not be suspended directly from junction box in the main conduit run.
- 5.20.21 Conduits and fittings shall be properly protected during construction period against mechanical injury. Conduits ends shall be plugged or capped to prevent entry of foreign material.
- 5.20.22 After installation the conduits shall be thoroughly cleaned by compressed air before pulling in the wire.
- 5.20.23 In control rooms and office areas provided with false ceiling conduit run shall be concealed type, embedded in the walls.
- 5.21.00 Wiring/Cabling
- 5.21.01 Wiring shall be generally carried out by PVC wires in conduits. All wires in a conduit shall be drawn simultaneously. No subsequent drawing is permissible.
- 5.21.02 Wire shall not be pulled through more than two equivalent 90° bends in a single conduit run.
- 5.21.03 Wiring shall be spliced only at junction boxes with approved type connections or terminal strips. Maximum two wires can be connected to each way of the terminal block. Splicing of only one phase shall be done in a junction box.
- 5.21.04 For lighting fixtures, connection shall be teed off through suitable round conduit or junction box, so that the connection can be attended without taking down the fixture.
- 5.21.05 For vertical run of wires in conduit, wires shall be suitably supported by means of wooden/hard rubber plugs at each pull/ junction box.
- 5.21.06 A.C. and D.C. circuits shall not be run in the same conduit and junction boxes. Circuits fed from different transformers shall be run through different conduits and Junction boxes.
- 5.21.07 Receptacle circuits shall be kept separate and distinct from lighting and fan circuits.
- 5.21.08 Separate neutral wire shall be provided for each circuit. Wiring throughout the installation shall be such that there is no break in the neutral wire in form of switch or fuse.
- 5.22.00 Cabling
- 5.22.01 In outdoor areas, main runs from lighting panels shall be by means of XLPE cables, directly buried in ground or laid in trenches for the underground portion and through conduit for the over ground portion.
- 5.22.02 Buried cables shall be laid and covered with sand/ riddled earth, and protected from damage by bricks at sides and pre cast concrete slab at top. Buried cables shall have cable markers at 50M interval and projecting 150 mm above ground. At cable bends and joints markers shall be provided.



- 5.22.03 When buried cables cross road/railway track, additional protection to be provided in form of hume / G.I. pipe.
- 5.23.00 Grounding
- 5.23.01 All lighting panels, junction boxes, receptacles, fixtures, conduit etc. shall be grounded in compliance with the provision of I.E. Rules.
- 5.23.02 Ground connections shall be made from nearest available station ground grid. All connections to ground grid shall be done by arc welding.
- 5.23.03 Lighting Panels shall be directly connected to ground grid by two nos. 35 x 6 mm G.S flats.
- 5.23.04 Street lighting Pole shall be grounded at two points by two nos. 50x6 mm G.I flat risers from two (2) nos. earthing spike 40 mm dia & 3m long directly driven into ground at a depth of 1m from ground level. The junction box at each lighting pole is grounded at two (2) points from two (2) nos. earthing terminals by 16 SWG GI wire.
- 5.23.05 One 16 SWG G.I wire shall be taken up to the junction box from lighting fixtures and connected to grounding point.
- 5.23.06 A continuous ground conductor of 16SWG GI Wire shall run along each exposed metallic conduit run and bonded to it every 600 mm by not less than two turns of the same size of wire. This conductor shall be connected to each panel ground bus.
- All junction boxes, receptacles, fixtures etc. shall be connected to this 16 SWG ground conductor.
- 5.24.00 Foundation & Civil Works
- 5.24.01 Equipment foundations, panel foundations and all other civil work will be provided by the Bidder at the option of owner.
- 5.25.00 Excavation and Back Filling
- 5.25.01 The Bidder shall perform all excavation and backfilling as required for buried cable and ground connections.
- 5.25.02 Excavation shall be performed up to the required depth. Such sheeting and shoring shall be done as may be necessary for protection of the work.
- 5.25.03 The Bidder shall make use of his own arrangements for pumping out any water that may be accumulated in the excavation.
- 5.25.04 All excavation shall be backfilled to the original level with good consolidation.
- 5.26.00 Steel Fabrication





- 5.26.01 All supports, hangers & brackets shall be fabricated by the Bidder. Necessary steel shall be supplied by the Bidder (optional).
- 5.26.02 Steel for fabrication shall be straightened and cleaned of rust and grease. All fabrication shall be free of sharp edge.
- 5.26.03 Every effort shall be made to minimize the wastage of steel as far as practicable during fabrication. The wastage in no case shall exceed 3% of the total quantity of steel fabricated.



- 5.28.00 Cleaning up of Work Site
- 5.28.01 The Bidder shall, from time to time, remove all rubbish resulting from execution of his work. No material shall be stored or placed on passage or drive ways.
- 5.28.02 Upon completion of work, the Bidder shall remove all rubbish, tools, scaffoldings, temporary structures and surplus materials etc. to leave the premises clean and fit for use.
- 5.29.00 Inspection & Testing
- 5.29.01 On completion of erection works, the Bidder shall request the Engineer for inspection and tests with minimum fourteen (14) days advance notice.
- 5.29.02 The Engineer shall arrange for joint inspection of the installation for completeness and correctness of the work. Any defect pointed out during such inspection shall be promptly rectified by the Bidder.
- 5.29.03 The installation shall be then tested and commissioned in presence of the Engineer and put on trial run for stipulated contract period.
- 5.29.04 All rectification, repair or adjustment work found necessary during inspection, testing, commissioning and trial run shall be carried out by the Bidder without any extra cost.
- 5.30.00 Taking Over of Installation
- 5.30.01 On successful testing, commissioning and trial run, the Bidder shall request Engineer in writing for taking over the installation.
- 5.30.02 The Engineer, on receipt of the request, shall arrange to take over the installation either wholly or in part as the case may be after a final inspection.



5.30.03 Till such taking over, the responsibility of the whole installation against theft or damage of any kind shall remain with the Bidder.

5.31.00 Guarantee

In the installation if any trouble arises due to the use of defective or faulty material and/or bad workmanship within a period of 12 months from the date of taking over, the Bidder shall guarantee to replace or repair the defective part(s) at site to the entire satisfaction of the Engineer free of charge.

6.00.00 TESTS

6.01.00 Shop Tests

6.01.01 All equipment shall be completely assembled, wired, adjusted and routine tested as per relevant Indian Standards at manufacturer's works.

6.01.02 Tests on lighting Distribution Boards/Panels shall include:

- a) Wiring continuity tests.
- b) High voltage and insulation tests.
- c) Operational tests.

6.02.00 Site Tests

6.02.01 Bidder shall thoroughly test and meggar all cables, wires and equipment to prove that the same are free from ground and short circuit.

6.02.02 If any ground or short circuit is found, the fault shall be rectified or the cable and/or equipment replaced.

6.02.03 All equipment shall be demonstrated to operate in accordance with the requirements of this specification.

6.02.04 Illumination in different areas are as per designed lux level should be established.

6.03.00 Test Witness

6.03.01 all test shall be performed in presence of Owner's representatives, if so desired by the Owner.

6.03.02 The Bidder shall give at least thirty (30) days advance notice of shop test seven (7) days advance notice of site tests.

6.04.00 Test Certificates

- a) Certified copies of all tests carried out at works and at site shall be furnished in requisite no. of copies for approval of the Owner.
- b) The equipment shall be dispatched from works only after receipt of Owner's written approval of shop test reports.





- c) Type test reports LM79 and LM80 (not more than 5 years from the date of opening of Techno-commercial BID) including Type test certificate on any equipment (if so desired by the Owner) shall be furnished. Otherwise the equipment shall have to be type tested, free of charge, to prove the design.

7.00.00 SPECIAL TOOLS AND TACKLE

- 7.01.00 A set of special tools and tackles which are necessary or convenient for erection, commissioning, maintenance and overhauling of the equipment shall be supplied.
- 7.02.00 The tools shall be shipped in separate containers, clearly marked with the name of the equipment for which they are intended.

8.00.00 SPARES

The Bidder shall submit a list of recommended spare parts for three (3) years satisfactory and trouble free operation, indicating the itemized price of each item of the spares.

9.00.00 DRAWINGS, DATA & MANUALS

- 9.01.00 Drawings, data and manuals shall be submitted in triplicate with the bid and in quantities and procedures as specified in the General Condition of Contract and/or elsewhere in this specification for approval and subsequent distribution after the issue of Letter of Intent.
- 9.02.00 To be submitted with the Bid
- 9.02.01 Make, type and catalogue number of lighting fixtures, lamps and accessories along with technical leaflets, data sheets, polar curves etc.
- 9.02.02 Typical outline drawings, showing constructional features, cable/ conduit entry, fixing arrangements etc of:
- a) Lighting Panel/receptacles/junction boxes.
 - b) Street light pole.
 - c) Flood light towers.
- 9.02.03 Technical leaflets and data sheet on each piece of equipment / device such as MCB, switch fuse, MCCB, receptacle etc.
- 9.02.04 Type test certificates on lighting fixtures and lighting panels, ballast, power cables.
- 9.03.00 To be submitted after Award of Contract





- 9.03.01 Detail dimensional drawing showing constructional features, cable/ conduit entry, grounding, fixing arrangement etc. of:
- a) Lighting panels.
 - b) Receptacles & Junction boxes.
 - c) Street light poles.
 - d) Flood light tower along with design calculations
 - e) Lighting fixture complete with lamps and accessories.
 - f) Non-integral/separate type control gearbox for lighting fixtures, as applicable.
- 9.03.02 Data sheets for lighting panels
- 9.03.03 Data sheets for lighting fixture, lamps, accessories with light distribution curves, co-efficient of utilization charts etc.
- 9.03.04 Control schematic and wiring diagram of 415V AC/220V DC lighting panel with automatic changeover from AC to DC and back to AC normal supply on restoration, 415V normal AC Street/area lighting panel with automatic ON/OFF feature.
- 9.03.05 Technical leaflets and data sheet on each piece of equipment/ device such as MCB, switch, fuse, receptacle etc. Type and routine test certificates of cables.
- 9.03.06 Lighting layouts showing the disposition of fixtures, lighting panels/boards, circuit distributions, conduit & wire routing.
- 9.03.07 Key Single Line Diagram for lighting distribution, board wise single line diagram with feeder loading, cable schedule and interconnection chart, design calculation for lighting.
- 9.03.08 AS-BUILT lighting layout and erection drawings, properly incorporating the changes/alterations/field modifications, if any, as carried out at field along with circuit distribution schemes of all lighting panels, conduit and cable routing and as acceptable to the Owner.
- 9.03.09 Any other relevant drawings, data and manuals necessary for satisfactory installation, operation and maintenance or as required by purchaser.
- 9.03.10 The Bidder may note that the drawings, data and manuals listed are minimum requirement only. The Bidder shall ensure that all other necessary write-ups, curves and information required to fully describe the equipment offered are submitted with his bid.



Annexure-A

AVAILABLE POWER SUPPLY

1.0 System Voltage

Lighting equipment and accessories shall be designed for satisfactory operation from the following power supply sources:

1.1 A.C. Supply : 415 Volt, 3 phase, 50 Hz, 4 wire effectively grounded system.

Fault Level 50KA r.m.s. symmetrical.

1.2 D.C. Supply : 220 V, 2 wire, ungrounded system.

Fault Level 25* KA

2.0 Permissible Variation

Equipment and accessories shall be suitable for operation over the entire range of voltage/frequency variations as listed below:

2.1 A.C. Supply : Voltage $\pm 10\%$

Frequency $\pm 5\%$

Combined Voltage 10% (absolute sum)
+ Frequency

D.C. Supply : Voltage 198 to 242 Volt.

* Minimum only; actual value will be decided by the Bidder after substantiating the same by calculation.





- Medium bay fixtures shall be used where the room height is 8 M. Otherwise high bay fixtures are to be used.
- Lux level for A.C. Emergency lighting in control room shall be 50 and for other areas 20 lux.
- Lux level for main road lighting shall be 20 and for secondary road shall be 10 lux.
- One no. (1) DC emergency fixture shall be provided at entry, exit and each landing of stair cases of Electrical Substation Buildings, Control Rooms, TPs etc.
- If Lux level of any specific area is not covered in above table, Vendor shall take specific confirmation from purchaser before finalization of Bid.





- 3.2 RB 16A, 240V, 2 pole, 3 pin with third pin earthed, wall/ column mounted, metal clad gasketed construction, 20mm conduit entry, screwed metal cover tied to it by a metal chain, weatherproof suitable for indoor/outdoor installation.

- 3.3 RC 63A, 415 V, 3 phase, 4 pin interlocked plug and switch with earthing contact, wall/column mounted, metal clad gasketed construction, weatherproof, suitable for loop-in/loop-out connection of 4/C-35 Sq.mm XLPE cable. These shall be fed from AC Distribution Board/Station

- 3.4 RD 125 A, 415 V, 3 phase 5 pin interlocked plug & switch with fifth pin earthed, wall/column mounted metal clad gasketed construction, weatherproof, suitable for loop in and loop out connection of 3-1/2C -95 Sq.mm XLPE cable. These shall be fed from A.C-Distribution Board/Station MCC. Application at all Transformer Yard for Oil Filtration machines and other areas. Degree of protection shall be IP 65.

4.0 CEILING FANS

- 4.1 FA 1200 mm sweep ceiling fan with regulator, down rod and canopy.
- 4.2 FB 1400 mm sweep ceiling fan with regulator, down rod and canopy.

5.0 LIGHTING POLES

- 5.1 TA/TB Single arm/double arm swaged and welded steel pole with junction box and all accessories.

6.0 SWITCHBOARD

- 6.1 S-1 Switch board with 1-6A switch.
- 6.2 S-2 Switch board with 3-6A switch and 1-6A receptacle.
- 6.3 S-3 Switch board with 6-6A switch and 1-6A receptacle.



ANNEXURE – F

**RATINGS AND REQUIREMENTS
 OF
 LIGHTING TRANSFORMER**

Type : Dry type, no encapsulated
VPI with nomex insulation

--	--

Voltage rating	:	415 V/415 V
Cooling	:	AN
P.V. Impedance	:	0.04 ± 10%
Voltage control	:	Off load tap switch/link with change of ± 5% in step of 2.5% tapping full capacity.
Vector Group	:	Dyn11
Class of Insulation	:	F (155°C)
Maximum Temperature rise over 50 Deg C. ambient in winding by resistance	:	90°C
Neutral	:	Solidly grounded.

The secondary neutral of the transformer shall be brought out for getting a grounded 4 wire supply. Each transformer shall be routine tested and one transformer shall be type tested in accordance with relevant standard.

The transformer shall be liable for rejection if the tolerance on the quoted values of losses, impedance, temperature rise, etc. exceeds the specified values of relevant standard.

The transformer shall be mounted inside sheet steel enclosure, which shall be an integral part of Lighting Distribution Board.



ILLUMINATION
NOTES & DETAILS

DWG. NO. 12A05-DWG-E-0800

12A05-DWG-E-0800 Sh. Cover 14.04.2017

FOR TENDER PURPOSE ONLY

1. The notes define some areas of responsibility and construction practices to be used. The symbols are used to save notes and space in generating and interpreting the drawings. The details provide typical examples of lighting installations. The words lighting fixture and receptacles used in this document is synonymous to luminaire and sockets. The installation / support details shown are typical installation details. The Contractor is responsible for the structural adequacy of the installation.
2. These lighting notes and details shall be read and construed in conjunction with the Illumination Layout and drawings.
3. Except specifically approved by site office, installation of exposed conduits, mounting of lighting fixtures etc. shall be taken up only after all other services such as Piping, Air Ducting, Cable Tray/Busduct Hanger, Structural Bracings etc. in a particular area have been installed.
4. The Contractor shall develop final conduit/cable routing based on fixture location and other site conditions.
5. Unless otherwise shown, the mounting heights of lighting fixtures and accessories shall be generally as follows :
 - a) i) Low-Bay Lighting Fixtures : upto 3500 mm from bottom in general indoor Areas of Industrial plants.
 - ii) Medium Bay Type Fixtures. : above 3500 mm from bottom
 - b) Bracket lights over door : 300 mm bottom of Fixture Above top of opening
 - d) Receptacles -
 - i) In control room/office : 300 mm from finished floor
 - ii) Elsewhere : 1000 mm from finished floor
 - e) Local Switches : 1500 mm from finished floor
 - f) Lighting Panels : 1200 mm from finished floor
6. All lighting fixtures shall be fed from respective lighting panel. Normal AC lighting will be fed from normal lighting panel. Emergency AC lighting panel which in-turn connected with UPS.
7. Switchboard shall be used in office area. Separate switchboard has been considered for normal & emergency supply.

FOR TENDER PURPOSE ONLY

					ILLUMINATION NOTES & DETAILS		 DEVELOPMENT CONSULTANTS PVT. LTD. CONSULTING ENGINEERS	
					WEST BENGAL POWER DEVELOPMENT CORPN. LTD. WEST BENGAL, INDIA		JOB NO. 12A05 SCALE : NTS	
DS	RD	RD	-	14.04.17	SAGARDIGHI THERMAL POWER EXTENSION PROJECT PHASE-III, UNITS # 5 (1 x 660 MW)		DWG. NO. 12A05-DWG-E-0800 REV.	
APPVD.	REVWD.	CHKD.	REV.	DATE			SHT. 01 OF 25	

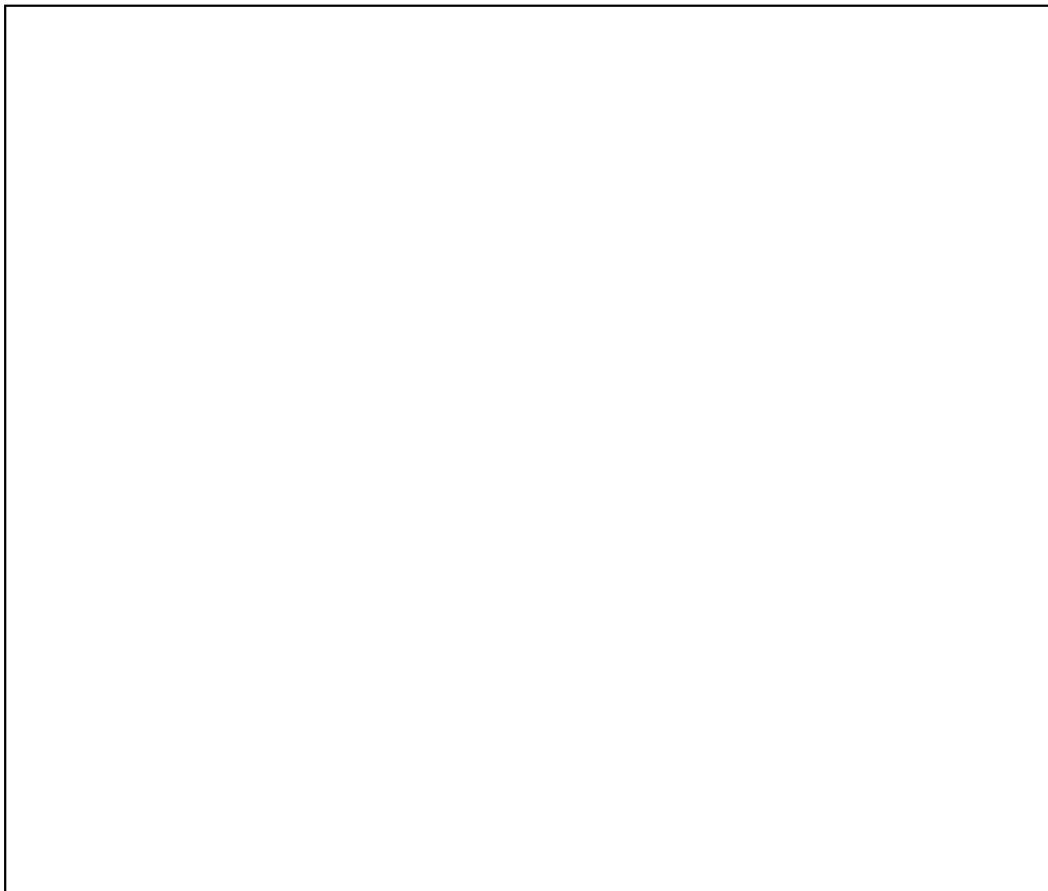

9. Receptacle circuits shall be kept separate and distinct from lighting circuits.
10. Lighting fixtures stems (pendants) shall be 19 mm galvanized rigid steel conduit. Recess mounted fixture shall be hanged through chain/stem as per installation facility available for particular fixture.
11. Wires/cable shall be spliced only at junction boxes with ring-tongue lugs or approved equal.
12. For cable/wire numbering, PVC sleeve with cable/wire Tag number of different colour code shall be used.
13. All lighting fixtures, local switches and receptacle outlets shall be grounded in accordance with IS 3043, NBC & IE rule. Multicore Multicore (multi-conductor) cable shall be provided with integral ground wire. Where multicore cables are not used, each lighting/small power circuits shall carry a separate ground wire.

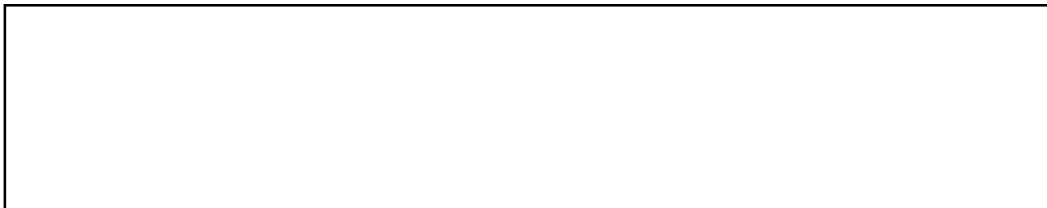

FOR TENDER PURPOSE ONLY

					ILLUMINATION NOTES & DETAILS				DEVELOPMENT CONSULTANTS PVT. LTD. CONSULTING ENGINEERS	
					WEST BENGAL POWER DEVELOPMENT CORPN. LTD. WEST BENGAL, INDIA		JOB NO. 12A05		SCALE : NTS	
DS	RD	RD	-	14.04.17	SAGARDIGHI THERMAL POWER EXTENSION PROJECT PHASE-III, UNITS # 5 (1 x 660 MW)		DWG. NO. 12A05-DWG-E-0800		REV.	
APPVD.	REVWD.	CHKD.	REV.	DATE			SHT. 02 OF 25		-	

SHEET 37 OF 40

14.04.2017

12A05-DWG-E-0800 Sh. 2 OF 25

A4_DD (9-96) [210x297]



B. CONDUITS

- i) Conduits for lighting fixtures and receptacles will not be shown on the lighting drawings. It is the responsibility of Contractor to detail the raceway system as required for the circuits shown on the lighting layouts and panel board/ lighting schedules.
- ii) Exposed conduit shall be installed either perpendicular or parallel to adjacent structural steel in a workmanlike manner.
- iii) Galvanized flexible metallic conduit may be used for recessed lighting fixtures in suspended ceilings and in other dry areas subject to vibration.
- iv) Conduits shall be run at least 460mm (18") apart from flues, insulated steam pipes or hot water pipes. They shall be supported every 2450mm (8'-0"). All supporting material shall be zinc coated.
- v) Raceway system shall be complete and continuous in all respects prior to pulling any cable. All fittings, wireways and boxes shall be properly grounded and bonded.
- vi) Raceway for luminaries (lighting) and sockets (receptacles) shall be independent and separate from all other power and control raceways. No cable tray shall be used for routing of lighting or receptacle branch circuits.
- vii) All raceways shall be terminated with insulated bushings or conduit hubs.
- viii) All embedded conduit shall be HDPE or rigid galvanized steel conduit, unless otherwise noted. Conduits installed in concrete shall be a minimum of 27mm (1") in diameter.
- ix) Exposed lighting and receptacle conduit in clean, dry, areas, where the raceway will not be subjected to mechanical damage may be electrical metallic tubing (EMT). EMT fittings shall be compression type.
- x) All conduits shall be of galvanised steel of following minimum sizes :

CABLE SIZE	CONDUIT. SIZE					Maximum No. of Conductors Admissible for conduit
	21MM	27MM	35MM	41MM	53MM	
a) 10 Sq.mm AL	-	2	5	7	8	} Maximum No. of Conductors Admissible for conduit
b) 2.5 Sq.mm CU	3	5	9	-	-	

C. JUNCTION BOXES

CONDUIT SIZE (MM)	JUNCTION BOX SIZE (MM)			
	4-WAY	3-WAY	STRAIGHT THROUGH	90°
a) 21 / 27	150x150x100	150x100x100	88 Ø	88 Ø
b) 35 / 41	254x200x127	254x200x127	150x150x100	-
c) 53	254x200x127	254x200x127	254x200x127	-

FOR TENDER PURPOSE ONLY

					ILLUMINATION NOTES & DETAILS		 DEVELOPMENT CONSULTANTS PVT. LTD. CONSULTING ENGINEERS	
					WEST BENGAL POWER DEVELOPMENT CORPN. LTD. WEST BENGAL, INDIA		JOB NO. 12A05	
					SAGARDIGHI THERMAL POWER EXTENSION PROJECT PHASE-III, UNITS # 5 (1 x 660 MW)		SCALE : NTS	
DS	RD	RD	-	14.04.17	DWG. NO. 12A05-DWG-E-0800		REV.	
APPVD.	REVWD.	CHKD.	REV.	DATE	SHT. 03 OF 25		-	

All lighting panels/distribution boards, junction boxes, receptacles, Fixtures, Conduits, etc. shall be grounded in compliance with the provision of I.E. rule and as detailed below :

- a) Lighting Panels : 25 x 3 MM G.S. Flat
- b) Distribution Boards : 50 x 6 MM G.S. Flat
- c) Power Receptacles, Junction Boxes etc : Third core of the three core cable
- d) Lighting fixtures, switches, conduits etc. : Third core of the three core cable

D. RECEPTACLES

- i) Receptacles shall be 16A, 240VAC single phase duplex type with earth (ground) and fed from 240V lighting/receptacle distribution boards.
- ii) Sockets (receptacles) should be located in convenient locations and spaced to provide access to any point with a 25 meters (85'-0") extension cord.

E. LOCAL SWITCHES

- i) Each local switch, light fixture, wall receptacle and other misc. devices in an office or room with hollow partitioned walls shall be flush mounted in a galvanized pressed steel outlet box of the knockout type of not less than 1.830 mm thick.
- ii) Local switches, light fixture, wall receptacles and other misc. devices in all other indoor locations shall be surface mounted in cast hub box (FD Cast Device Box or equal) with sheet steel covers.
- iii) Local switches, light fixtures, receptacles and other misc. devices in hazardous areas, corrosive areas or areas exposed to the weather shall be surface mounted in outlet boxes with covers approved for the particular conditions involved.
- iv) Motion controlled light sensors shall be provided in hallways and conference rooms to enable switching off lights when not required.
- v) Light switches shall be placed at the entry point of rooms. Where there are two entry points to a room, three way switches shall be employed. When there are three or more entry points to a room, four way switches shall be employed. If three or four way switches has current limitations for controlling the number of lighting fixtures, local switch with auxiliary relay and contactor shall be used for controlling the lighting fixtures.
- vi) Switches controlling light fixtures and exhaust fans of battery room shall be located outside of the battery room.
15. The electrical installation work shall met the requirements of Indian Electricity Rules, relevant IS codes of practice and safety codes, all as amended upto date. In addition, other rules or regulations as applicable to the work shall be followed. In case of any discrepancy, the more restrictive rule shall be binding.
16. Typical details of lighting fixtures, other lighting system components and their mounting arrangement as shown herein are for general guidance only, The type no. of some make has been referred in the various drawings. Only to indicate desired appearance, construction features and performance of the fixture. The contractor has to design the same fulfilling the requirement of the specification.

FOR TENDER PURPOSE ONLY

					ILLUMINATION NOTES & DETAILS		 DEVELOPMENT CONSULTANTS PVT. LTD. CONSULTING ENGINEERS	
					WEST BENGAL POWER DEVELOPMENT CORPN. LTD. WEST BENGAL, INDIA		JOB NO. 12A05	
DS	RD	RD	-	14.04.17	SAGARDIGHI THERMAL POWER EXTENSION PROJECT PHASE-III, UNITS # 5 (1 x 660 MW)		SCALE : NTS	
APPVD.	REVVD.	CHKD.	REV.	DATE			DWG. NO. 12A05-DWG-E-0800	
							SHT. 04 OF 25	

17. Lightnig fixtures numbering system is as follows :

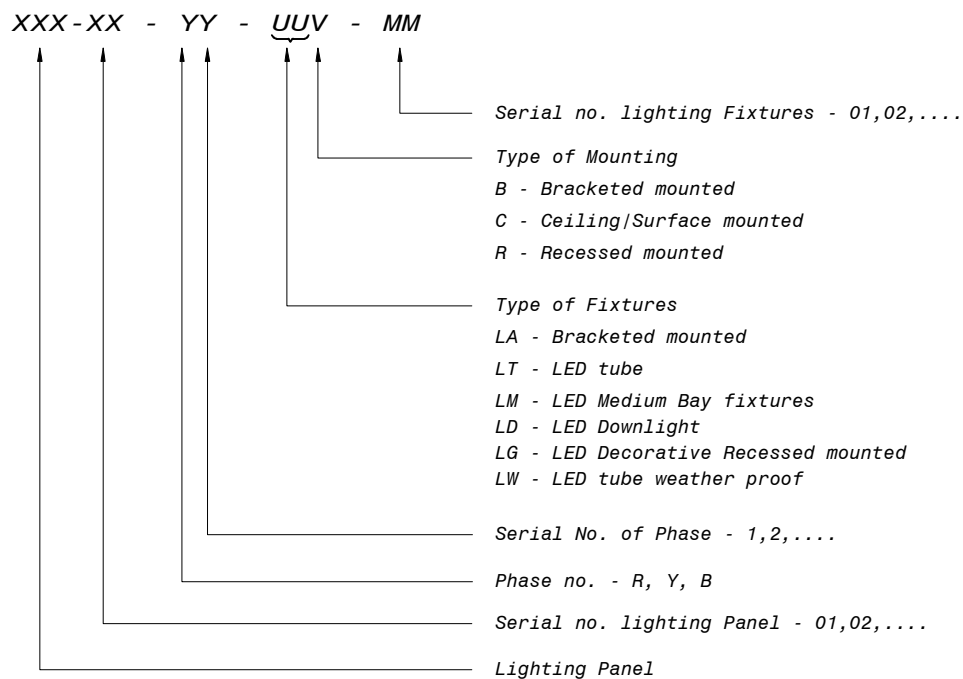

12A05-DWG-E-0800 Sh. 5 OF 25 14.04.2017

FOR TENDER PURPOSE ONLY

					ILLUMINATION NOTES & DETAILS		 DEVELOPMENT CONSULTANTS PVT. LTD. CONSULTING ENGINEERS	
					WEST BENGAL POWER DEVELOPMENT CORPN. LTD. WEST BENGAL, INDIA			
DS	RD	RD	-	14.04.17	SAGARDIGHI THERMAL POWER EXTENSION PROJECT PHASE-III, UNITS # 5 (1 x 660 MW)		JOB NO. 12A05 SCALE : NTS	
APPVD.	REVWD.	CHKD.	REV.	DATE			DWG. NO. 12A05-DWG-E-0800	

	STANDARD QUALITY PLAN		SPEC. NO.:	DATE:
	CUSTOMER :		QP NO.:PE-QP-999-558-E001, R04	DATE: 23.06.2020
	PROJECT:		PO NO.:	DATE:
	ITEM: LIGHTING FIXTURES, LAMPS & MISC. ITEMS		SYSTEM:STATION LIGHTING SYSTEM	SECTION: II

SL NO.	COMPONENT & OPERATIONS	CHARACTERIST ICS	CLASS	TYPE OF CHECK	QUANTUM OF CHECK	REFERENCE DOCUMENT	ACCEPTAN CE NORMS	FORMAT OF RECORD	AGENCY	REMARKS
1	2	3	4	5	6 M C/ N	7	8	9 * D	** M C N	

1.0 CONVENTIONAL TYPE LIGHTING FIXTURES

Bought out items / in-process checks										
A										
1.1	Lamps	Make rating & type	Major	Visual	1 sample per type	Approved Data Sheet for rating & type, Make to be BIS approved with CML number	Approved Data Sheet for rating & type, Make to be BIS approved with CML number		P/ V *	Refer note No. 1
1.2	Electronic Ballast (if applicable)	Certificate of compliance	Major	Visual	Mnfr std.	Approved Data Sheet	Certificate of compliance by ballast manufacturer /lighting fixture that supplier meets all requirements. Approved Data Sheet	Certificate of compliance report	P/ V *	Refer note No. 1
		THD and pf check	Major	Electrical	Mnfr std.	Approved Data Sheet	THD<=10%, pf>=0.9 for FH type and pf>=0.95 for other type of fluorescent lighting fixtures	Inspection report	P/ V *	Refer note No. 1

ENGINEERING				QUALITY			
Sign & Date	Name	Sign & Date	Name	Sign & Date	Name	Sign & Date	Name
Prepared by: 09.07.2020	MEET SAGAR SINGH RAIPAL	Checked by: 09.07.20	KUNAL GANDHI				
Reviewed by:	PRAVEEN DUTTA	Reviewed by: Digitally signed by RITESH KUMAR JAISWAL					

Date: 2020.07.10 20:27:48 +05'30'

BIDDER / SUPPLIER	
Sign & Date	
Seal	

FOR CUSTOMER REVIEW & APPROVAL	
Doc No:	
Reviewed by:	Sign & Date Name Seal
Approved by:	

	STANDARD QUALITY PLAN		SPEC. NO.:		DATE:
	CUSTOMER :		QP NO.: PE-QP-999-558-E001, R04		DATE: 23.06.2020
	PROJECT:		PO NO.:		DATE:
	ITEM: LIGHTING FIXTURES, LAMPS & MISC. ITEMS		SYSTEM: STATION LIGHTING SYSTEM		SECTION: II

SL NO.	COMPONENT & OPERATIONS	CHARACTERIST ICS	CLASS	TYPE OF CHECK	QUANTUM OF CHECK			REFERENCE DOCUMENT	ACCEPTAN CE NORMS	FORMAT OF RECORD	AGENCY				REMARKS
					M	C	N				M	C	N		
1	2	3	4	5	6	C	7	8	9	*	D	**			
1.3	Castings	Freedom from defects	Major	Visual	Mnfr std.	-	Approved Data Sheet	Casting shall be free from any defects such as blow holes, surface blisters, cracks and cavities etc.	Inspection report			P/ V *	-	Refer note No. 1	
1.4	Sheet metal forming and fabrication	Freedom from defects	Major	Visual	Mnfr std.	-	Approved Data Sheet	Sheet metal fabrication / forming etc should be as per manufacturer drgs.	Inspection report			P/ V *	-	Refer note No. 1	
1.5	Pre-treatment and powder coating	Pre-treatment process checks, Powder Coating finish, thickness, uniformity of coating and adhesion	Major	Visual, chemical & mech	Mnfr std.	-	Mnfr standard, Approved Data Sheet	Nominal coating thickness 50 microns or more	Inspection report			P/ V *	-	Refer note No. 1	
B. ACCEPTANCE TEST															

ENGINEERING				QUALITY			
Sign & Date	Name	Si	Date	Si	Date	Name	Name
Prepared by:	MEET SAGAR SINGH RAJPAL	Checked by:	09.07.2020	Checked by:	09.07.20	KUNAL GANDHI	
Reviewed by:	PRAVEEN DUTTA	Reviewed by:	Digitally signed by RITESH KUMAR JAISWAL				

Date: 2020.07.10 20:28:22 +05'30'

FOR CUSTOMER REVIEW & APPROVAL			
Doc No:		Sign & Date	Seal
Reviewed by:		Sign & Date	Seal
Approved by:			

BIDDER/ SUPPLIER			
Sign & Date		Sign & Date	Seal
Seal			

	STANDARD QUALITY PLAN		SPEC. NO.:		DATE:
	CUSTOMER :		QP NO.: PE-QP-999-558-E001, R04		DATE: 23.06.2020
	PROJECT:		PO NO.:		DATE:
	ITEM: LIGHTING FIXTURES, LAMPS & MISC. ITEMS		SYSTEM: STATION LIGHTING SYSTEM		SECTION: II

SL NO.	COMPONENT & OPERATIONS	CHARACTERISTICS	CLASS	TYPE OF CHECK	QUANTUM OF CHECK			REFERENCE DOCUMENT	ACCEPTANCE NORMS	FORMAT OF RECORD	AGENCY				REMARKS
					M	C	N				M	C	N		
1	2	3	4	5	6	C	N	7	8	9	*	D	**		
		a) VISUAL	MA	VISUAL	IS 10322 (PART 5 SEC1)	IS 10322 (PART 5 SEC1)	IS 10322 (PART 5 SEC1)	IS 10322 / APPD GA	IS 10322 / APPD GA	Inspection report	✓	P	W	W	
		b) IR (Dry)	CR	Electrical	IS 10322	IS 10322	IS 10322	IS 10322	IS 10322	Inspection report	✓	P	W	W	
		c) HIGH VOLTAGE	CR	Electrical	IS 10322	IS 10322	IS 10322	IS 10322	IS 10322	Inspection report	✓	P	W	W	
		d) DUST PROOF	CR	Electrical	IS 10322	IS 10322	IS 10322	IS 10322	IS 10322	Inspection report	✓	P	W	W	
		e) PHOTOMETRIC	CR	Electrical	IS-10322	IS-10322	*	IS 10322	IS 10322	Inspection report	✓	P	W	W	*: One no. Luminaire of each type to be witnessed by BHEL/ Customer
2. ROUTINE TEST															
		a) VISUAL	MA	Visual	IS 10322 (PART 5 SEC1)	IS 10322 (PART 5 SEC1)	IS 10322 (PART 5 SEC1)	IS 10322 / APPD GA	IS 10322 / APPD GA	Test cert	✓	P	V	-	
		b) IR (Dry)	CR	Electrical	IS 10322	IS 10322	IS 10322	IS 10322	IS 10322	Test cert	✓	P	V	-	
		c) HIGH VOLTAGE	CR	Electrical	IS 10322	IS 10322	IS 10322	IS 10322	IS 10322	Test cert	✓	P	V	-	

KUNAL
09.07.20 GANDHI

ENGINEERING				QUALITY			
Prepared by:	MEET SAGAR SINGH RAJPAL	Checked by:	MEET SAGAR SINGH RAJPAL	Sign & Date	09.07.20	Name	KUNAL GANDHI
Reviewed by:	PRAVEEN DUTTA	Reviewed by:	RITESH KUMAR JAISWAL	Digitally signed by:	09.07.20	Name	RITESH KUMAR JAISWAL

Date: 2020.07.10 20:28:57 +05'30'

BIDDER/ SUPPLIER				FOR CUSTOMER REVIEW & APPROVAL			
Sign & Date				Doc No:			
Seal				Sign & Date		Name	
				Reviewed by:		Seal	
				Approved by:			

		STANDARD QUALITY PLAN				SPEC. NO.:		DATE:
		CUSTOMER :				QP NO.:PE-QP-999-558-E001, R04		DATE: 23.06.2020
		PROJECT:				PO NO.:		DATE:
		ITEM: LIGHTING FIXTURES, LAMPS & MISC. ITEMS		SYSTEM:STATION LIGHTING SYSTEM		SECTION: II		SHEET 4 OF 10

SL NO.	COMPONENT & OPERATIONS	CHARACTERISTICS	CLASS	TYPE OF CHECK	QUANTUM OF CHECK			REFERENCE DOCUMENT	ACCEPTANCE NORMS	FORMAT OF RECORD	AGENCY				REMARKS
					M	C	N				M	C	N		
1	2	3	4	5	6	C	N	7	8	9	*	D	**		

2.0 LED TYPE LIGHTING FIXTURES

A Bought out items / in-process checks															
SL NO.	COMPONENT & OPERATIONS	CHARACTERISTICS	CLASS	TYPE OF CHECK	Mnfr. Std.	Mnfr. Std.	Mnfr. Std.	Appd Data Sheet	LM 80 report	Appd Data Sheet	LM 80 report	Appd Data Sheet	LM 80 report	Appd Data Sheet	LM 80 report
1.1	LED chip	LED chip efficacy LED chip CRI & CCT	Major	Visual	-	-	-	LM 80 report	LM 80 report	LM 80 report	LM 80 report	LM 80 report	LM 80 report	LM 80 report	LM 80 report
1.2	LED Driver	Reported TM21 (L80) lifetime of LED chip Compatibility with LED module / chip, controls & protection features	Major	Visual	-	-	-	Appd Data Sheet	Certificate of Compliance	Appd Data Sheet	Certificate of Compliance	Appd Data Sheet	Certificate of Compliance	Appd Data Sheet	Certificate of Compliance
		THD & pf check	Major	Electrical	Mnfr. Std.	-	-	Appd Data Sheet	Inspection report	THD <10% and pf >=0.9	Inspection report	THD <10% and pf >=0.9	Inspection report	Inspection report	Inspection report

FOR CUSTOMER REVIEW & APPROVAL														
Doc No:														
Reviewed by:														
Approved by:														

BHEL															
ENGINEERING					QUALITY					BIDDER / SUPPLIER					
Sign & Date	Name	Sign & Date	Name	Sign & Date	Name	Sign & Date	Name	Sign & Date	Name	Sign & Date	Name	Sign & Date	Name	Sign & Date	Name
Prepared by:	MEET SAGAR SINGH RAJPAL	09.07.2020	Checked by:	KUNAL GANDHI	09.07.20	Reviewed by:	PRAVEEN DUTTA	Digitally signed by RITESH KUMAR JAISWA	Reviewed by:	KUNAL GANDHI	09.07.20	Approved by:	RITESH KUMAR JAISWA	Digitally signed by RITESH KUMAR JAISWA	09.07.20

Date: 2020.07.10 20:29:34 +05'30

	STANDARD QUALITY PLAN		SPEC. NO.:		DATE:
	CUSTOMER :		QP NO.: PE-QP-999-558-E001, R04		DATE: 23.06.2020
	PROJECT:		PO NO.:		DATE:
	ITEM: LIGHTING FIXTURES, LAMPS & MISC. ITEMS		SYSTEM: STATION LIGHTING SYSTEM		SECTION: II
SHEET 5 OF 10					

SL NO.	COMPONENT & OPERATIONS	CHARACTERIST ICS	CLASS	TYPE OF CHECK	QUANTUM OF CHECK			REFERENCE DOCUMENT	ACCEPTAN CE NORMS	FORMAT OF RECORD	AGENCY				REMARKS
					M	C	N				M	C	N		
1	2	3	4	5	6	C/ N	7	8	9	*	D	**			
1.3	Castings	Freedom from defects	Major	Visual	Mnfr. Std.	-	Mnfr. Std.	Castings shall be free from any defects such as blow holes, surface blisters, cracks and cavities etc.	Inspection report			P/ V *	-	Refer note No. 1	
1.4	Sheet metal forming and fabrication	Freedom from defects	Major	Visual	Mnfr. Std.	-	Mnfr. Std.	Mnfr. Std.	Inspection report			P/ V *	-	Refer note No. 1	
1.5	Pre-treatment and powder coating	Pre-treatment process checks, Powder Coating finish, thickness, uniformity of coating and adhesion	Major	Visual, chemical & mech	Mnfr. Std.	-	Mnfr. Std.	Nominal coating thickness 50 microns or more	Inspection report	✓		P/ V *	V	Refer note No. 1	

ENGINEERING				QUALITY			
Sign & Date	Name	Sign & Date	Name	Sign & Date	Name	Sign & Date	Name
Prepared by: 09.07.2020	MEET SAGAR SINGH RAJPAL	Checked by: 09.07.20	KUNAL GANDHI	Reviewed by: PRAVEEN DUTTA	Reviewed by: RITESH KUMAR JAISWAL	Digitally signed by RITESH KUMAR JAISWAL	

Date: 2020.07.10 20:30:04 +05'30'

BIDDER/ SUPPLIER	
Sign & Date	
Seal	

FOR CUSTOMER REVIEW & APPROVAL			
Doc No:		Sign & Date	Name
Reviewed by:			Seal
Approved by:			

	STANDARD QUALITY PLAN		SPEC. NO :	DATE:
	CUSTOMER :		QP NO.:PE-QP-999-558-E001, R04	DATE: 23.06.2020
	PROJECT:		PO NO.:	DATE:
	ITEM: LIGHTING FIXTURES, LAMPS & MISC. ITEMS		SYSTEM:STATION LIGHTING SYSTEM	SECTION: II

SL NO.	COMPONENT & OPERATIONS	CHARACTERISTICS	CLASS	TYPE OF CHECK	QUANTUM OF CHECK			REFERENCE DOCUMENT	ACCEPTANCE NORMS	FORMAT OF RECORD				AGENCY	REMARKS
					M	C	N			D	M	C	N		
1	2	3	4	5	6	C	N	7	8	9	*	D	**		

Acceptance Tests on LED Lighting fixtures														
1	LED Lighting fixture	Details of lot offered and Certificate of Compliance of lighting fixture supplier has inspected the offered lot as per their own standard.	Major	Visual	-	-	Lighting fixtures supplier to submit the details of lot offered for inspection (Type of lighting fixtures, their batch number, sub-vendor, name, quantity)	-	List	✓	P	V	V	The list may be used for sample selection.
2	LED Lighting fixture	LED chip make	Major	Visual	-	-	Accepted type test reports (LM80/LM79) report	Certificate of compliance	Certificate of compliance	✓	V	V	V	
3	LED Lighting fixture	Constructional features including: Internal wiring, terminal block, earthing terminal, safety chain (if applicable)	Major	Visual	1	1	Approved data sheet/drg.	Approved data sheet/drg.	Inspection report	✓	P	W	W	
4	LED Lighting fixture	Resistance to moisture test in	Major	Mechanical	1	1	IS 10322 / Approved data	Approved data sheet	Inspection report	✓	P	W	W	

ENGINEERING				QUALITY				FOR CUSTOMER REVIEW & APPROVAL				
Prepared by:	MEET SAGAR SINGH RAJPAL	Checked by:	09.07.2020	Sign & Date	Sign & Date	Name	Seal	Reviewed by:	Approved by:	Sign & Date	Name	Seal
Reviewed by:	PRAVEEN DUTTA	Reviewed by:	Digitally signed by RITESH KUMAR JAISWAL									

Date: 2020.07.10 20:30:34 +05'30'

		MANUFACTURER/ SUPPLIER NAME & ADDRESS BIDDER/ SUPPLIER NAME & ADDRESS		STANDARD QUALITY PLAN				SPEC. NO. : QP NO.:PE-QP-999-558-E001, R04		DATE: DATE: 23.06.2020	
								PROJECT: PO NO.:		SECTION: II	
ITEM: LIGHTING FIXTURES, LAMPS & MISC. ITEMS		SYSTEM: STATION LIGHTING SYSTEM		CUSTOMER :		PROJECT:		SECTION: II		DATE:	

SL NO.	COMPONENT & OPERATIONS	CHARACTERIST ICS	CLASS	TYPE OF CHECK	QUANTUM OF CHECK			REFERENCE DOCUMENT	ACCEPTAN CE NORMS	FORMAT OF RECORD				AGENCY	REMARKS
					M	C	N			M	C	N	D		
1	2	3	4	5	6	C/ N	7	8	9	*	D	**			
5		case of lighting fixtures having IP X4 and above rating. Resistance to dust (applicable if IP5X and above)	Major	Optical	Mnfr. Std.	-	IS 10322 / Approved data sheet/drg.	Approved data sheet/drg	Certificate of compliance	✓	P/ V *	V	V	Refer note No. 1	
6		Photometry check	Major	Optical	Mnfr. Std.	-	LM79, IS 16106, IS 16107	Certificate of compliance for the batch: that offered lighting fixture LOR and lighting fixtures efficacy is not be less than 90% (refer IS 16107) with reference to type test reports.	Certificate of compliance	✓	P/ V *	V	V	Refer note No. 1	
7		Dimensions	Major	Visual	1 Sample per type	1	Approved data sheet/drg.	Approved data sheet/drg.	Inspection report	✓	P	W	W		
8		LED driver: THD and pf check	Major	Visual	1 Sample	1	Approved data sheet	THD<10% and pf >= 0.9	Certificate of	✓	P	W	W	At lighting fixtures supplier test lab.	

BHEL			
ENGINEERING		QUALITY	
Sign & Date	Sign & Date	Sign & Date	Sign & Date
Prepared by: 09.07.2020	MEET SAGAR SINGH RAJPAL	Checked by: 09.07.20	Name: KUNAL GANDHI
Reviewed by:	PRAVEEN DUTTA	Reviewed by: Digitally signed by RITESH KUMAR JAISWAL	Name: RITESH KUMAR JAISWAL
Date: 2020.07.10 20:31:04 +05'30'		Date: 2020.07.10 20:31:04 +05'30'	

BIDDER/ SUPPLIER	
Sign & Date	Sign & Date
Reviewed by:	Name
Approved by:	Seal

FOR CUSTOMER REVIEW & APPROVAL	
Doc No:	Sign & Date
Reviewed by:	Name
Approved by:	Seal

	MANUFACTURER/ SUPPLIER NAME & ADDRESS BIDDER/ ADDRESS STANDARD QUALITY PLAN		SPEC. NO. : QP NO.: PE-QP-999-558-E001, R04		DATE: DATE: 23.06.2020	
	PROJECT: SYSTEM: STATION LIGHTING SYSTEM		PO NO.: SECTION: II		DATE: SHEET 8 OF 10	
	ITEM: LIGHTING FIXTURES, LAMPS & MISC. ITEMS		ACCEPTANCE NORMS		AGENCY	
	CLASS		REFERENCE DOCUMENT		FORMAT OF RECORD	

SL NO.	COMPONENT & OPERATIONS	CHARACTERISTICS	CLASS	TYPE OF CHECK	QUANTUM OF CHECK	REFERENCE DOCUMENT	ACCEPTANCE NORMS	FORMAT OF RECORD	AGENCY	REMARKS	
1	2	3	4	5	6	7	8	9	**		
					M	C	N	D	M	C	N

9	LED driver: Precision current control check	Major	Electrical	1 Sample per type	Approved data sheet	compliance	Approved data sheet	Inspection report	P	W	W
10	LED driver: Open circuit protection simulation check	Major	Electrical	1 Sample per type	Approved data sheet	Inspection report	Approved data sheet	Inspection report	P	W	W
11	LED driver: short circuit protection simulation check	Major	Electrical	1 Sample per type	Approved data sheet	Inspection report	Approved data sheet	Inspection report	P	W	W
12	LED driver: over temperature protection simulation check	Major	Electrical	1 Sample per type	Approved data sheet	Inspection report	Approved data sheet	Inspection report	P	W	W
13	LED driver: overload protection simulation check	Major	Electrical	1 Sample per type	Approved data sheet	Inspection report	Approved data sheet	Inspection report	P	W	W
14	LED driver: surge protection compliance check	Major	Electrical	-	Approved data sheet	Certificate of compliance that surge protection is provided.	Approved data sheet	Certificate of compliance	V	V	V

ENGINEERING			QUALITY		
Prepared by:	MEET SAGAR SINGH RAJPAL	Checked by:	09.07.2020	Sign & Date	Name
Reviewed by:	PRAVEEN DUTTA	Reviewed by:	Digitally signed by RITESH KUMAR JAINSWAL	Sign & Date	Name

Date: 2020.07.10 20:31:35 +05'30'

FOR CUSTOMER REVIEW & APPROVAL		
Doc No:	Sign & Date	Name
Reviewed by:	Sign & Date	Name
Approved by:	Sign & Date	Name

	MANUFACTURER/ SUPPLIER NAME & ADDRESS		BIDDER/ SUPPLIER NAME & ADDRESS		STANDARD QUALITY PLAN		SPEC. NO. :		DATE:	
					CUSTOMER :		QP NO.: PE-QP-999-558-E001, R04		DATE: 23.06.2020	
					PROJECT:		PO NO.:		DATE:	
					ITEM: LIGHTING FIXTURES, LAMPS & MISC. ITEMS		SYSTEM: STATION LIGHTING SYSTEM		SECTION: II	

SL NO.	COMPONENT & OPERATIONS	CHARACTERISTICS	CLASS	TYPE OF CHECK	QUANTUM OF CHECK	REFERENCE DOCUMENT	ACCEPTANCE NORMS	FORMAT OF RECORD	AGENCY	REMARKS
1	2	3	4	5	6	7	8	9	**	
					M C/N			D	M C N	

3.0 JUNCTION BOXES & RECEPTACLES

A Acceptance Tests											
	Dimensions	Major	MEASUREMENT	100%	-	Appd Drawing	Appd Drawing	Inspection report	P	V	Components shall be of approved Make At the time of final Inspection
1	Paint Shade/ Thickness	Major	VISUAL/MEAS.	SAMPLE	-	Appd Drawing	Appd Drawing	Inspection report	P	V	
2	HV/ IR	Major	ELECT. TESTS	100%	-	2KV AC FOR 1 MINUTE	2KV AC FOR 1 MINUTE	Inspection report	P	V	
3	Degree Of Protection	Major	TEST	1/SIZE	-	IS:2147	IS:2147	TEST CERT.	P	V	
4	Special tests if any, explosion proof etc.	Major	TEST	1/SIZE	-	IS:2148	IS:2148	TEST CERT.	P	V	
5	Operation Check	Major	TEST	10%	-	Appd Drawing	Appd Drawing	Inspection report	P	V	
6	Mechanical Interlock	Major	TEST	10%	-	Appd Drawing	Appd Drawing	Inspection report	P	V	

4.0 PACKING

PACKING	Soundness of Packing against transit damage	Major	Visual	100%	100%	BHEL approved document	BHEL approved document	Inspection report	P	W	
---------	---	-------	--------	------	------	------------------------	------------------------	-------------------	---	---	--

ENGINEERING			QUALITY		
Prepared by:	MEET SAGAR SINGH RAJPAL	Checked by:	Sign & Date:	Name:	KUNAL GANDHI
Reviewed by:	PRAVEEN DUTTA	Reviewed by:	Digitally signed by:	RITESH KUMAR JAISWAL	Date: 2020.07.10 20:32:09 +05'30'

BIDDER/ SUPPLIER		
Sign & Date	Seal	

FOR CUSTOMER REVIEW & APPROVAL		
Doc No:	Sign & Date	Name
Reviewed by:		Seal
Approved by:		

		MANUFACTURER/ BIDDER/ SUPPLIER NAME & ADDRESS		STANDARD QUALITY PLAN			SPEC. NO :		DATE:	
		CUSTOMER :					QP NO.: PE-QP-999-558-E001, R04		DATE: 23.06.2020	
PROJECT:							PO NO.:		DATE:	
ITEM: LIGHTING FIXTURES, LAMPS & MISC. ITEMS		SYSTEM: STATION LIGHTING SYSTEM					SECTION: II		SHEET 10 OF 10	
SL NO.	COMPONENT & OPERATIONS	CHARACTERIST ICS	CLASS	TYPE OF CHECK	QUANTUM OF CHECK	REFERENCE DOCUMENT	ACCEPTANCE NORMS	FORMAT OF RECORD	AGENCY	REMARKS
1	2	3	4	5	M 6 C/N	7	8	9 D	M C N	

NOTES:

- P/V*- means test will be performed either by lighting fixture supplier or their sub-vendor and verified by lighting fixture supplier.
- Project specific QP shall be based on customer requirement. In case, any changes in QP commented by customer at contract stage shall be carried out by bidder without any implication to BHEL/ Customer.
- For export jobs, BHEL technical specification for seaworthy packing for export jobs is to be followed.
- Packing shall be suitable for storage at site in tropical climatic conditions.
- Latest revision/ year of issue of all the standards (IS/ ASME/ IEC etc.) Indicated in QP shall be referred.
- BHEL reserves the right for conducting repeat test if required.
- Items like ceiling fans, emergency lighting unit, flexible conduit, 24V supply module, ladders, hume pipe, switchboxes, exit signs etc. Will be cleared based on COC (certificate of compliance).
- After packing and prior to issue MDCC, photographs of items to be dispatched shall be sent to BHEL purchase group for review.

LEGENDS:

*Records, identified with "Tick"(✓) shall be essentially included by supplier in QA Documentation,
 ** M: Supplier/ Manufacturer/ Sub-Supplier, C: Main supplier/ BHEL/ Third Party Inspection Agency, N: Customer,
 P: Perform, W: Witness, V: Verification, as appropriate
 MA: Major, Mi: Minor, CR: Critical, D: Documentation

ENGINEERING				QUALITY			
Prepared by:	09.07.2020	MEET SAGAR SINGH RAJPAL	Checked by:	09.07.20	KUNAL GANDHI	Sign & Date	Name
Reviewed by:		PRAVEEN DUTTA	Reviewed by:		JAISWAL	Digitally signed by RITESH KUMAR	Seal
				BHEL			
				FOR CUSTOMER REVIEW & APPROVAL			
Doc No:				Sign & Date			
Reviewed by:				Name			
Approved by:				Seal			

Date: 2020.07.10 20:32:46 +05'30'

ANNEXURE-II

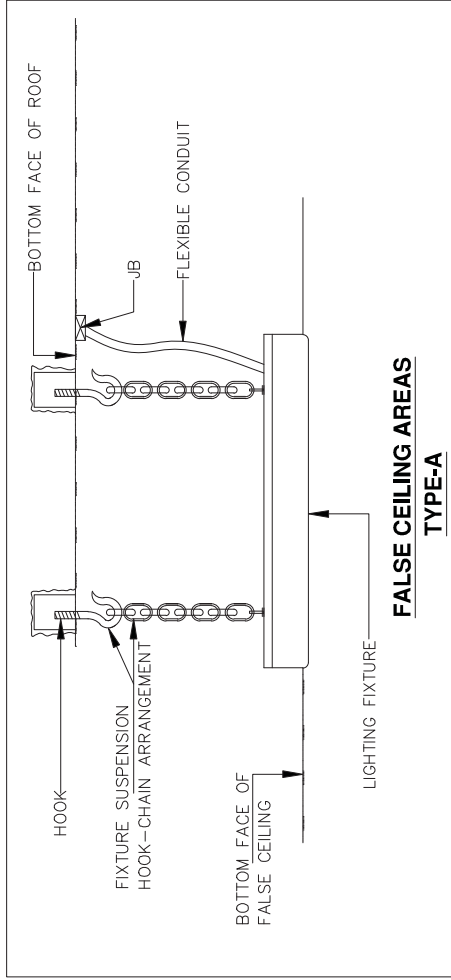

**FALSE CEILING AREAS
TYPE-A**

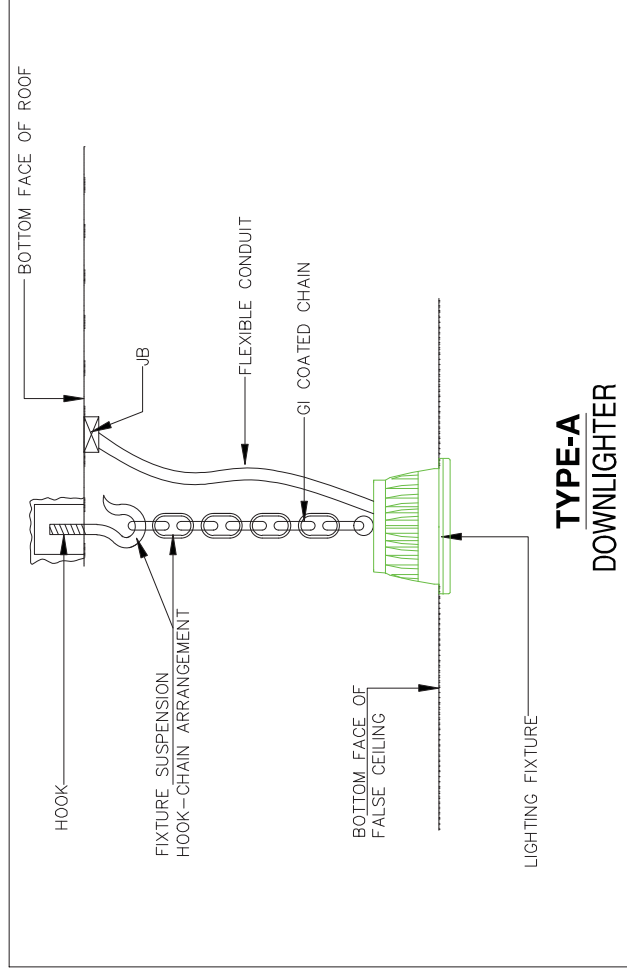

**TYPE-A
DOWNLIGHTER**

This is a Typical mounting arrangement dwgs/ details for guidance only. Final Mounting arrangement dwg shall be made by the successful bidder during detailed Engineering. It is to be noted that GI Conduit 20mm Dia and Flexible PVC Coated Conduit, Structural Steel shall be provided by BHEL. Balance all other accessories clamps/ chains/ clips/ steel rope/ pins etc required for mounting as per typical mounting arrangement for their fixtures shall be part of fixtures only and shall be provided by the Bidders.

2. In Lighting layout, Mounting arrangement also shown. If any Discrepancy found on both documents than consult with Design Incharge/Site Incharge.
3. Quantity of material shown in drawing may be change or vary as per site requirement.
4. If any new type of mounting fixture is required at site, then this arrangement shall be optimized or change the arrangement with prior inform to BHEL site Incharge.
5. All structural steel parts/supporting parts shall be hot dip galvanized as per IS 800/15.

SIZE-A4

ANNEXURE-II

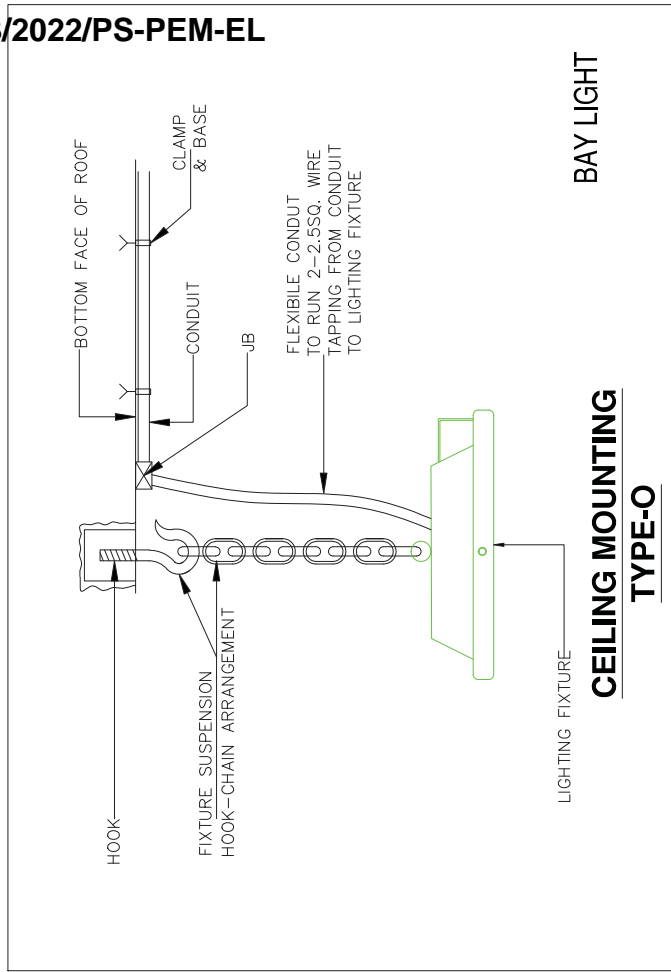
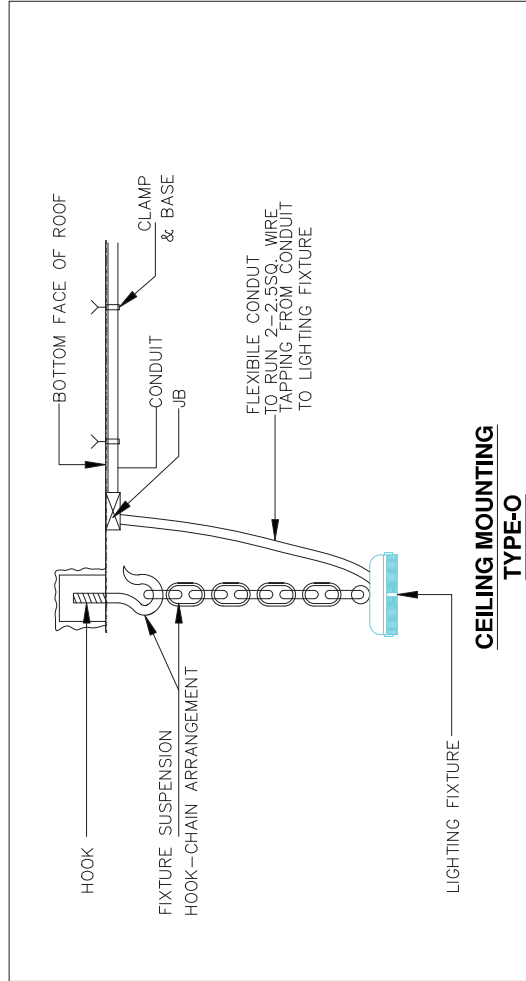
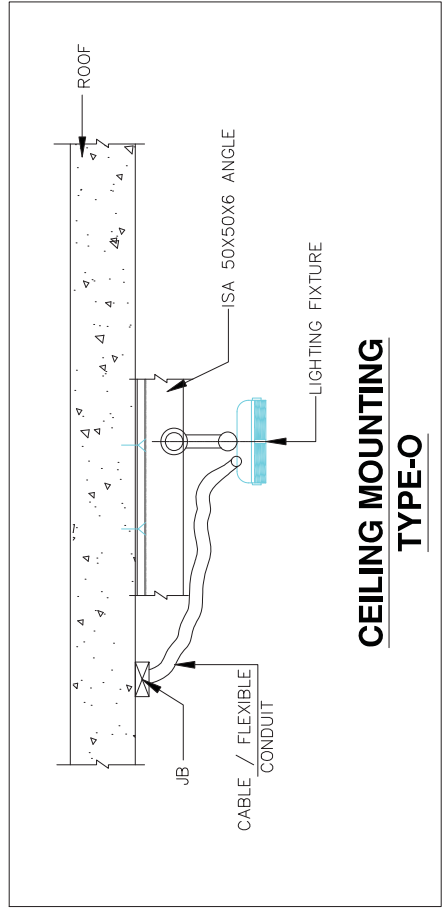

- General Notes:
1. Mounting arrangement can be changed/ modified on site as per site requirements.
 2. In Lighting layout, Mounting arrangement also shown, if any Discrepancy found on both documents than Consult with Design Incharge/ Site Incharge.
 3. Quantity and Material shown in drawings are indicative only and may be change or vary as per site requirement.
 4. In any new type of mounting required at site, then we can optimized or change the arrangement with prior inform to BHEL site Incharge.
 5. All structural steel parts/supporting parts shall be hot dip galvanized as per B02/IS.

SIZE-A4

ANNEXURE-II

SHEET 3 OF 3

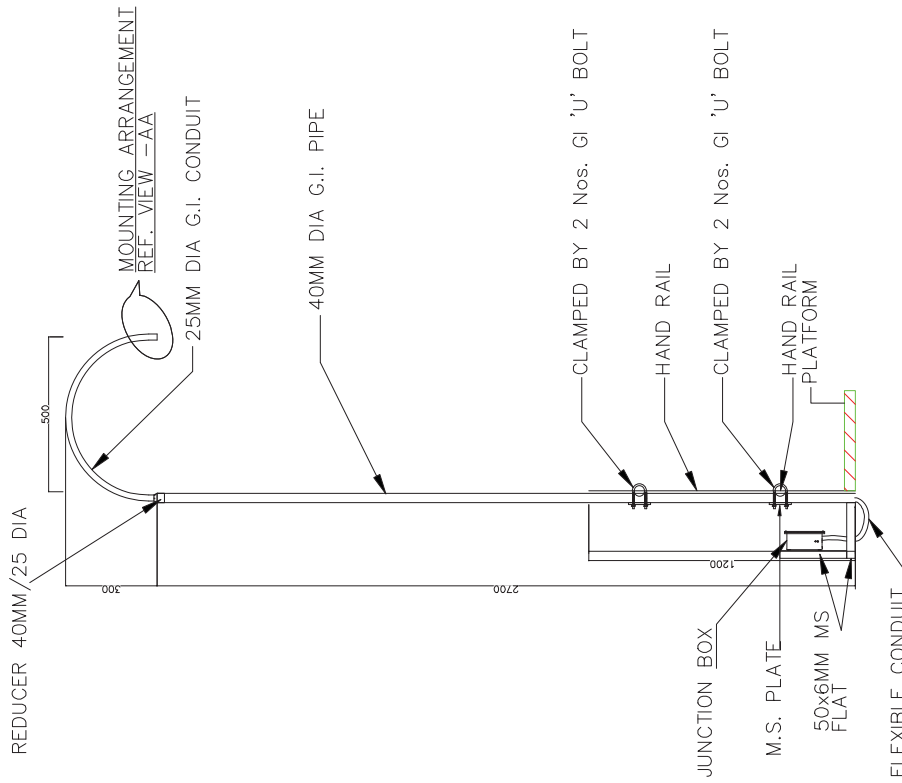

**HAND RAIL MOUNTING
TYPE-I**

- General Notes:
1. Mounting arrangement can be changed/ modified on site as per site requirements.
 2. In Lighting layout, Mounting arrangement also shows, if any Discrepancy found on both documents, then consider with Design Incharge/Site Incharge.
 3. On any site, the mounting arrangement may be change or vary as per site requirement.
 4. If any new type of mounting fixture is introduced on site, then the arrangement shall be optimized or change the arrangement with prior inform to BHEL site Incharge.
 5. All structural steel parts/supporting parts shall be hot dip galvanized as per IS 5007/5.

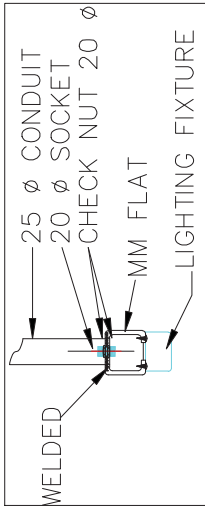
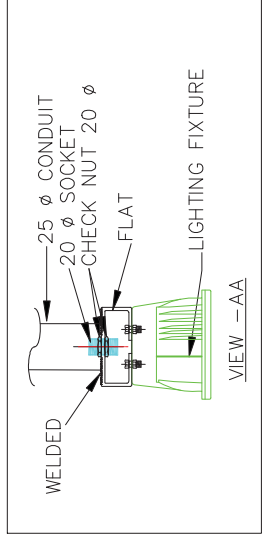
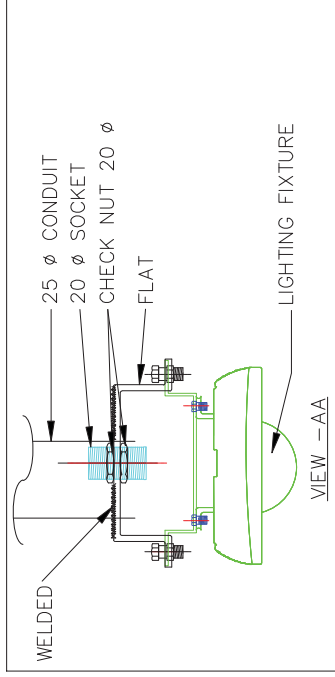

SIZE-AA

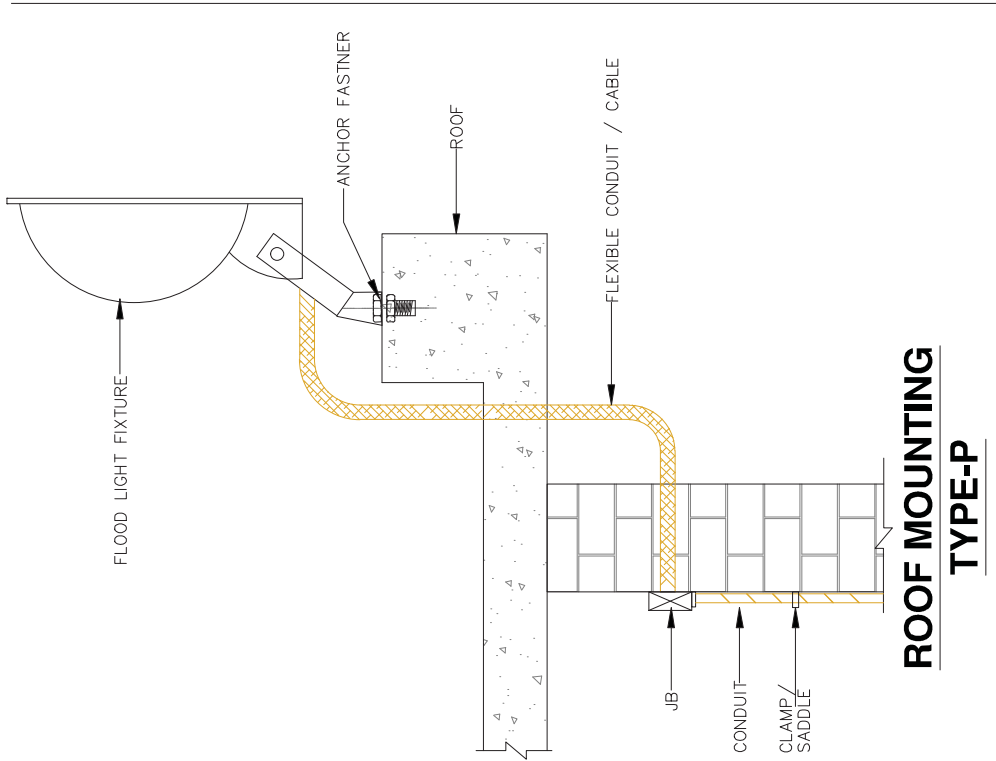
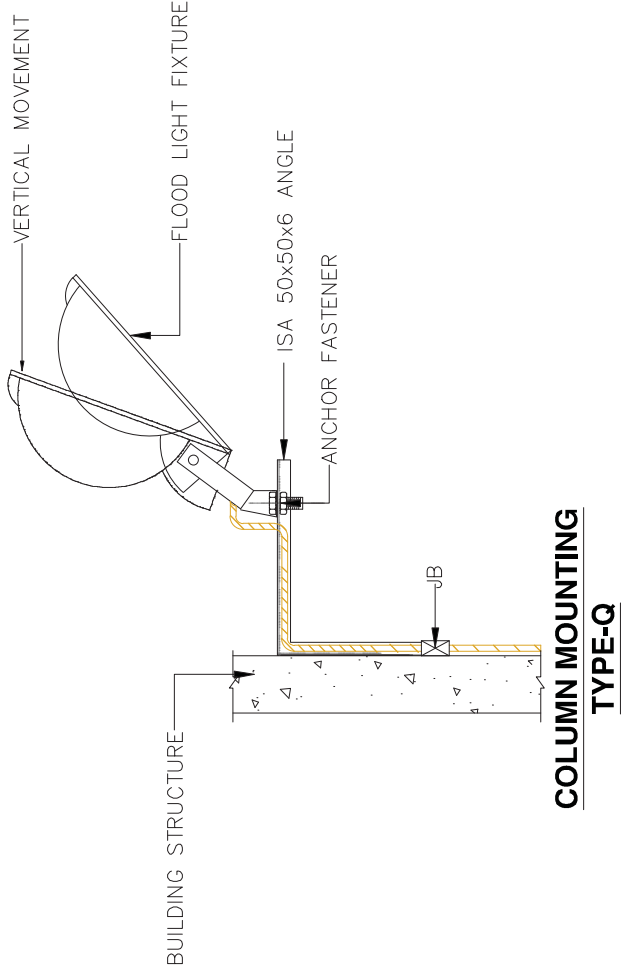

- General Notes:
1. Mounting arrangement can be changed/ modified on site as per site requirements.
 2. In Lighting layout, Mounting arrangement also shows, If any Discrepancy found on both documents then consider with Design Incharge/Site Incharge.
 3. On any type of mounting fixture, the design shall be optimized as per site requirement.
 4. If any new type of mounting fixture, then the design shall be optimized or change the design arrangement with prior inform to BHEL site Incharge.
 5. All structural steel parts/supporting parts shall be hot dip galvanized as per IS 800/15.

SIZE-A4

ANNEXURE-II

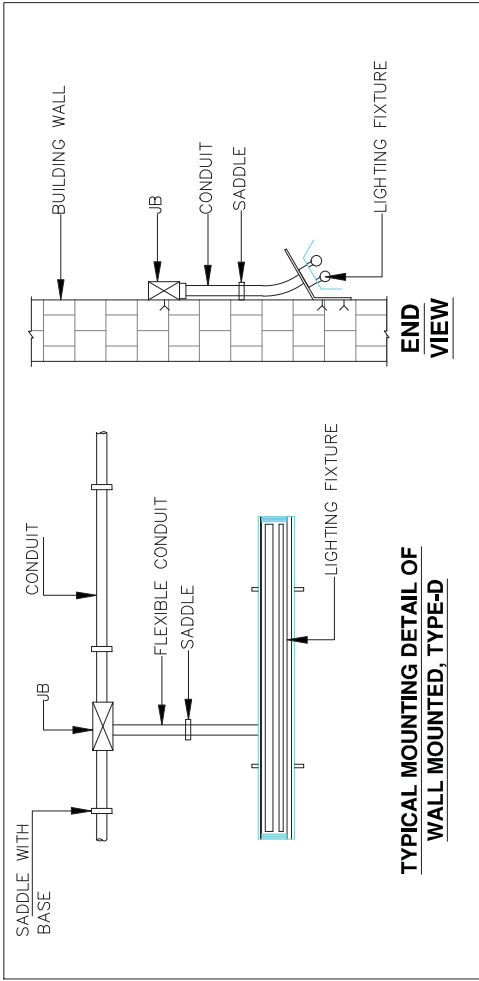

TYPICAL MOUNTING DETAIL OF WALL MOUNTED, TYPE-D

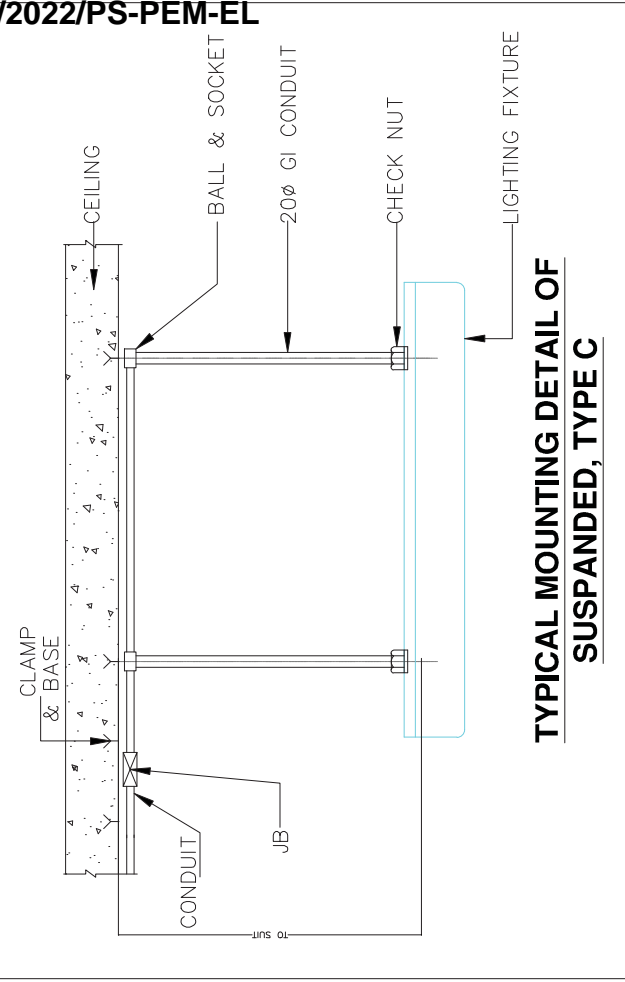

TYPICAL MOUNTING DETAIL OF SUSPENDED, TYPE C

- General Notes:
1. Mounting arrangement can be changed/ modified on site as per site requirements.
 2. In Lighting layout, Mounting arrangement also shows, if any Discrepancy found on both documents, then consult with Design Incharge/Site Incharge.
 3. Conduit and mounting fixture may be change or vary as per site requirement.
 4. If any new type of mounting fixture on site, then we can optimize or change the arrangement with prior inform to BHEL site Incharge.
 5. All structural steel parts/supporting parts shall be hot dip galvanized as per IS 800/15.

SIZE-A4

ANNEXURE-II

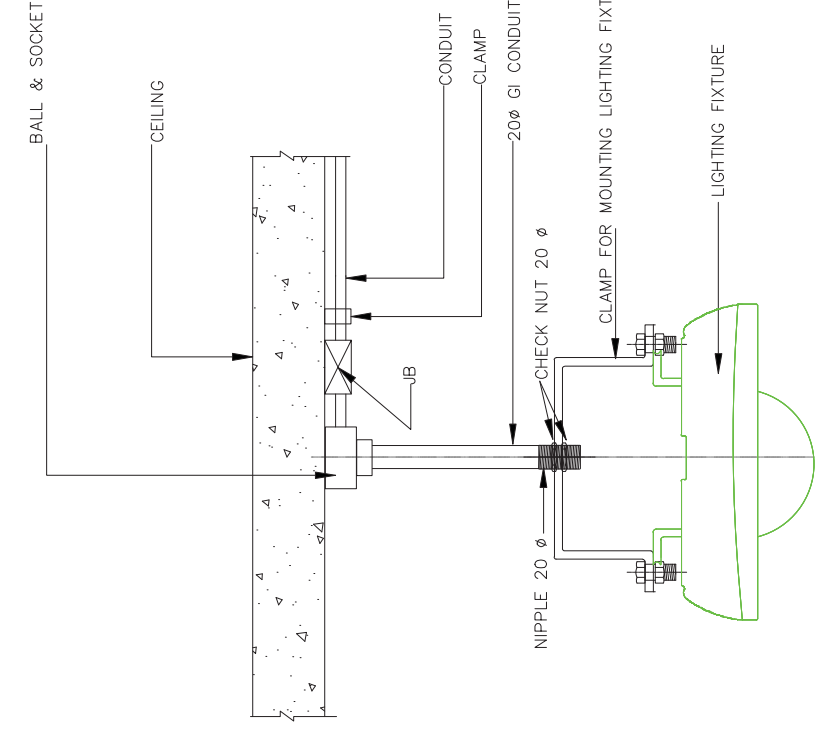

**SUPPORTED FROM CEILING
TYPE-F**

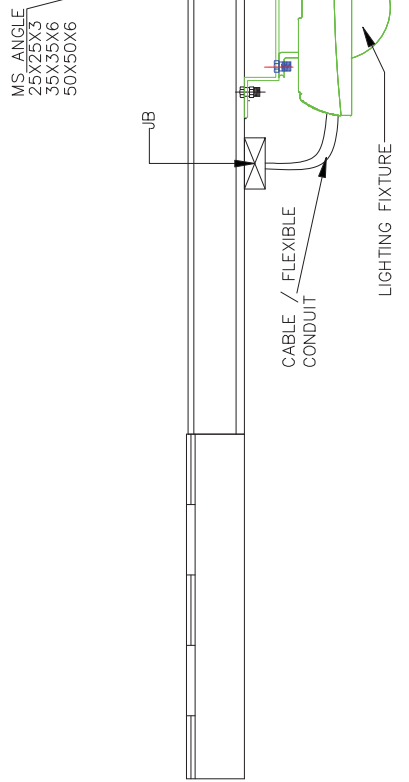

**SUPPORTED FROM CHANNEL/
STRUCTURAL STEEL
TYPE-G**

- General Notes:
1. Mounting arrangement can be changed/ modified on site as per site requirements.
 2. In Lighting layout, Mounting arrangement also shows, If any Discrepancy found on both documents, then consult with Design Incharge/Site Incharge.
 3. On any type of mounting fixture, the design shall be optimized or change as per site requirement.
 4. If any new type of mounting fixture, then the design shall be optimized or change the arrangement with prior inform to BHEL site Incharge.
 5. All structural steel parts/supporting parts shall be hot dip galvanized as per IS 800/15.

SIZE-A4

ANNEXURE-II

SHEET 7 OF

01 02 03 04 05 06 07 08

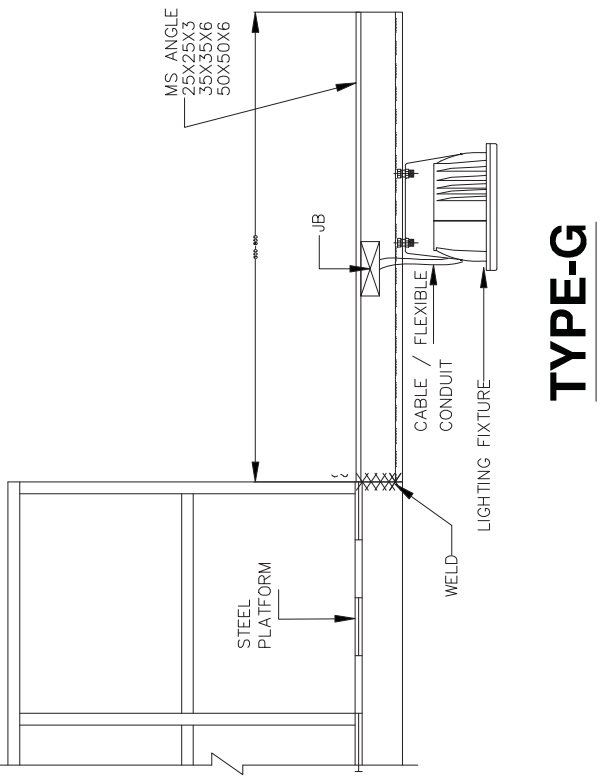

TYPE-G

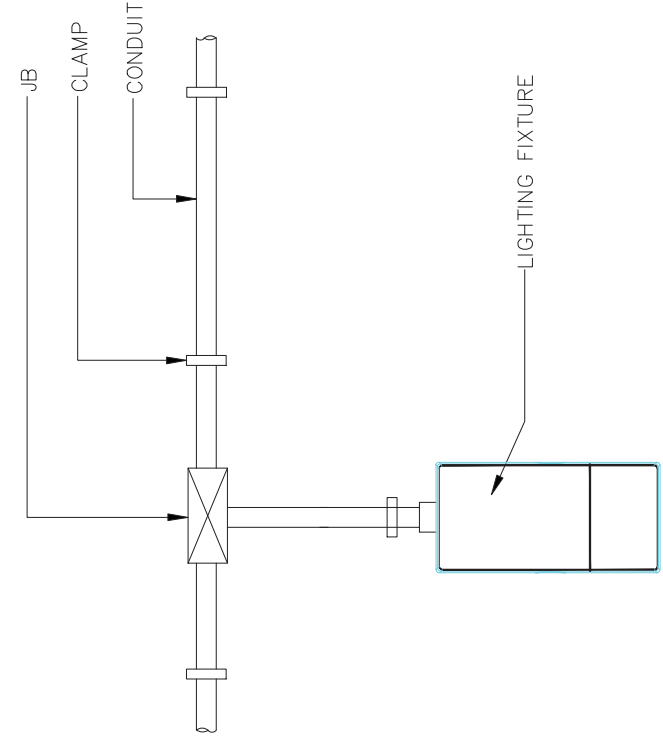

**WALL MOUNTING
TYPE-H**

- General Notes:
1. Mounting arrangement can be changed/ modified on site as per site requirements.
 2. In Lighting layout, Mounting arrangement also shows, if any Discrepancy found on both documents, then consider with Design Incharge/Site Incharge.
 3. On any type of mounting fixture, the design shall be optimized as per site requirement.
 4. If any new type of mounting fixture, then the design shall be optimized or change the design arrangement with prior inform to BHEL site Incharge.
 5. All structural steel parts/supporting parts shall be hot dip galvanized as per BQO/PS.

SIZE-A4

01 02 03 04 05 06 07 08

ANNEXURE-II

SHEET 8 OF 11

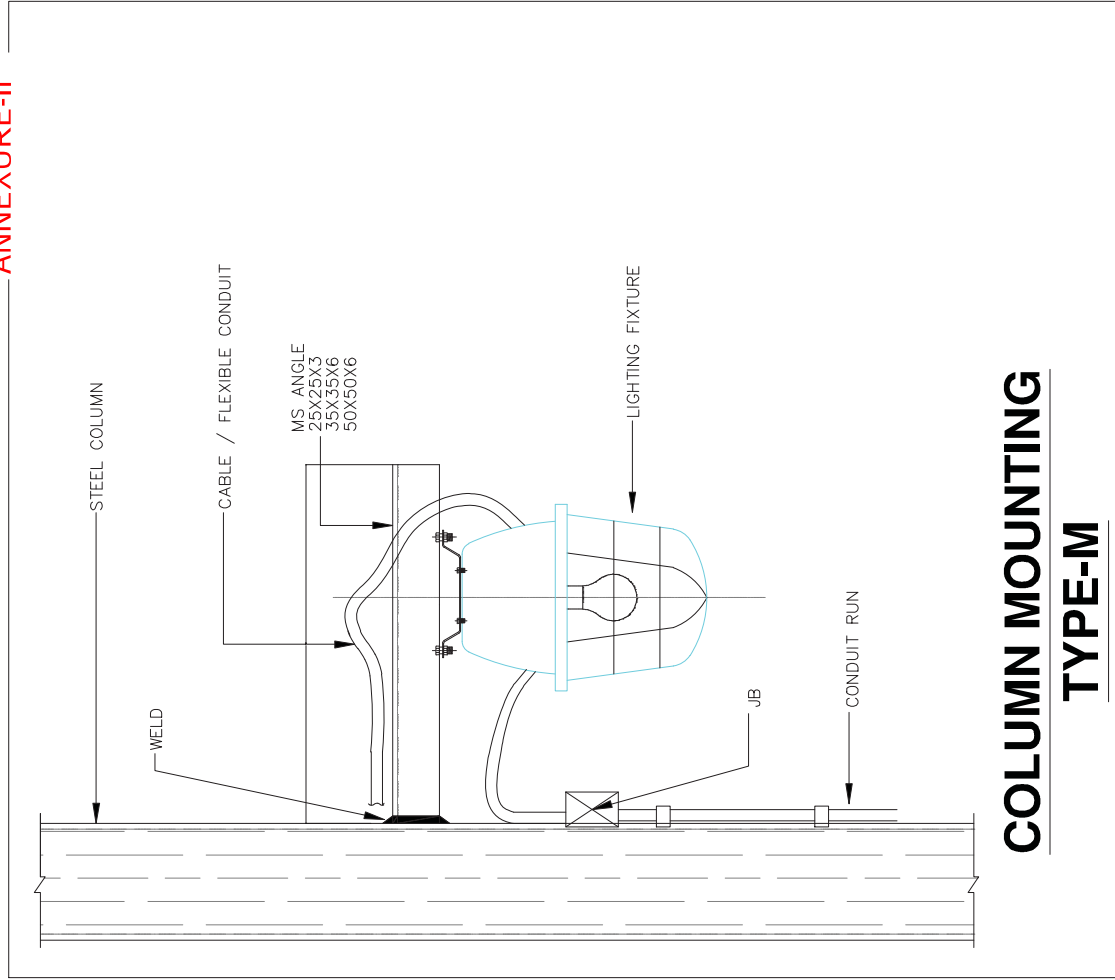

**COLUMN MOUNTING
TYPE-M**

- General Notes:
1. Mounting arrangement can be changed/ modified on site as per site requirements.
 2. In Lighting layout, Mounting arrangement also shown, if any Discrepancy found on both documents than Consult with Design /Site Incharge.
 3. Quantity and Material shown in drawings are indicative only and may be change or vary as per site requirement.
 4. If any new type of mounting required at site than we can optimized or change the arrangement with prior inform to BHEL site incharge.
 5. All structural steel parts/supporting parts shall be hot dip galvanized as per B00/TS.

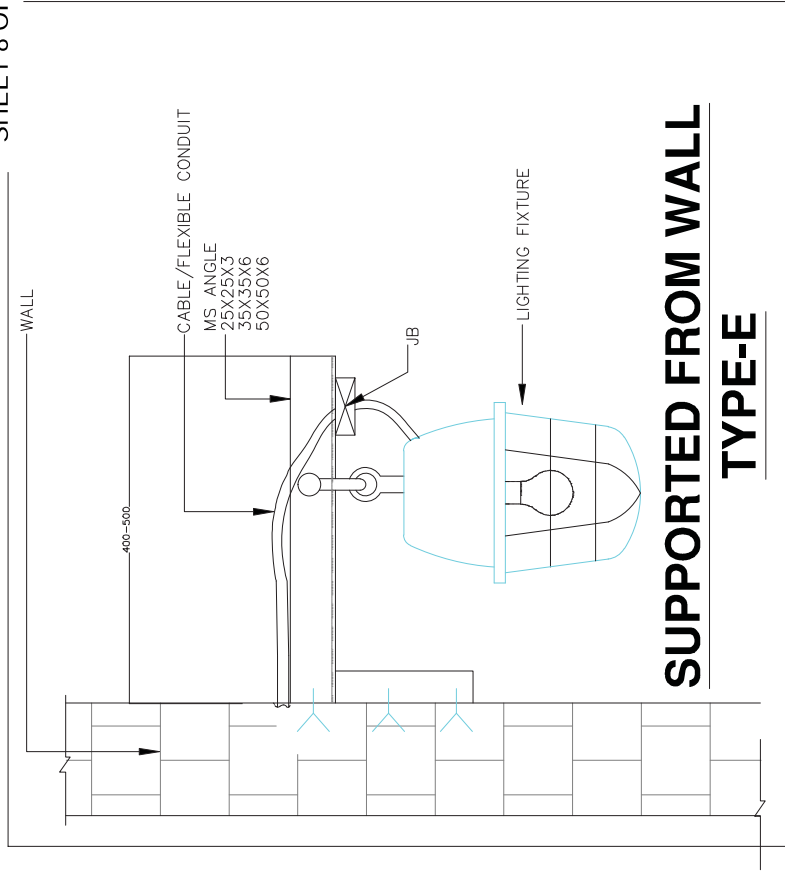

**SUPPORTED FROM WALL
TYPE-E**

SIZE-A4

ANNEXURE-II

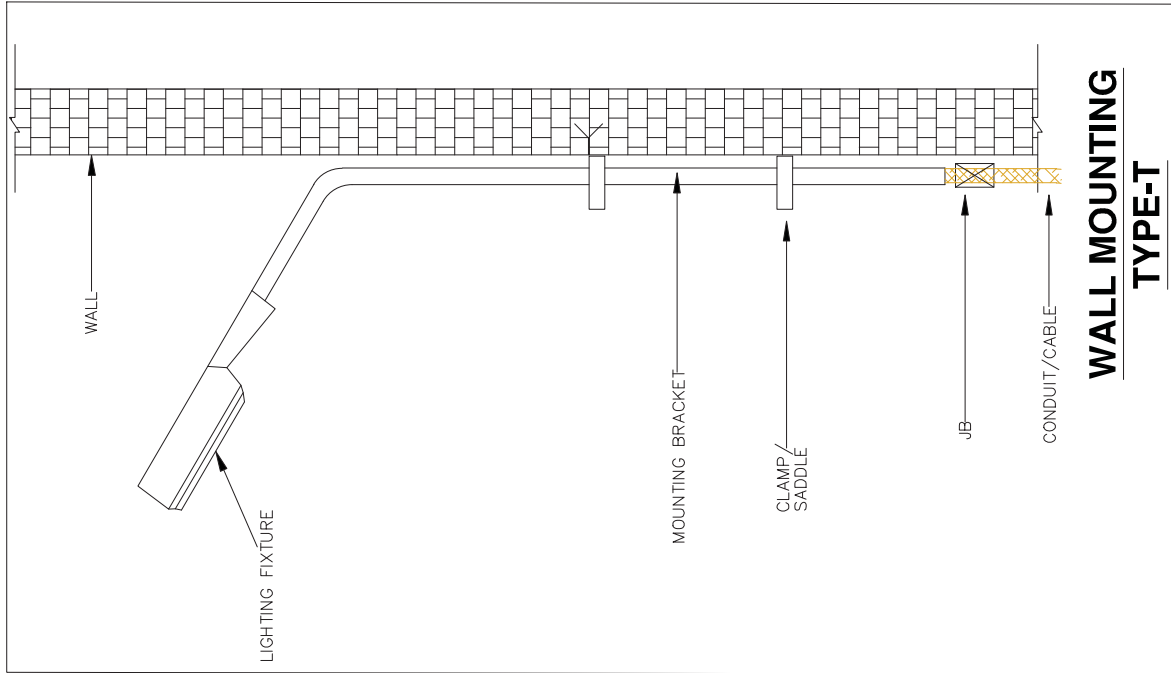

- General Notes:
1. Mounting arrangement can be changed/ modified on site as per site requirements.
 2. In Lighting layout, Mounting arrangement also shown. If any discrepancy found on both documents than Consult with Design Incharge/Site Incharge.
 3. Quantity and Material shown in drawings are indicative only and may be change or vary as per site requirement.
 4. If any new type of mounting required at site than we can optimized or change the arrangement with prior inform to BHEL site Incharge.
 5. All structural steel parts/supporting parts shall be hot dip galvanized as per B00/TS.

SIZE-A4

ANNEXURE-II

SHEET 10 OF 10

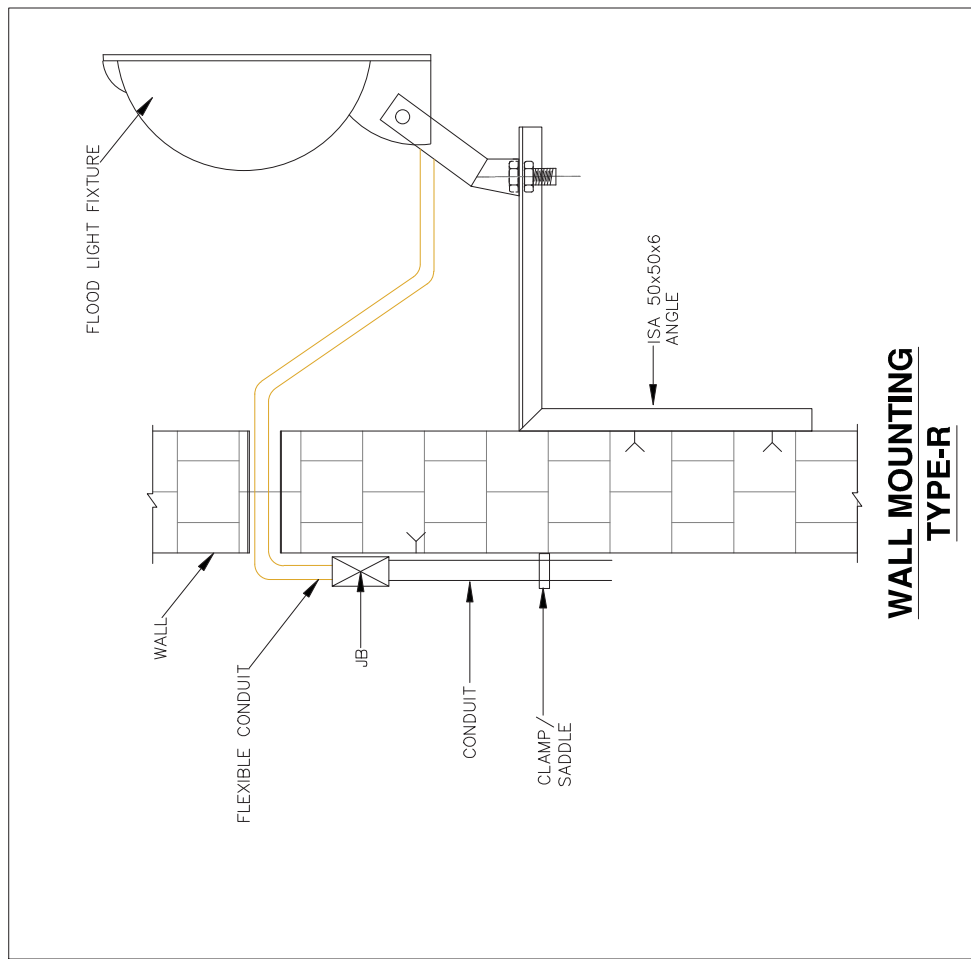

**WALL MOUNTING
TYPE-R**

- General Notes:
1. Mounting arrangement can be changed/ modified on site as per site requirements.
 2. In Lighting Layout, Mounting arrangement also shown. If any discrepancy found on both documents than Consult with Design Incharge/Site Incharge.
 3. Quantity and Material shown in drawings are indicative only and may be change or vary as per site requirement.
 4. If any new type of mounting required at site than we can optimized or change the arrangement with prior inform to BHEL site incharge.
 5. All structural steel parts/supporting parts shall be hot dip galvanized as per B00/TS.

SIZE-A4