

**TAMILNADU GENERATION & DISTRIBUTION CORPORATION
LIMITED**

**1x800 MW TANGEDCO NORTH CHENNAI TPP (FGD
SYSTEM)**

TECHNICAL SPECIFICATION

FOR

HVAC SYSTEM

SPECIFICATION NO.: - PE-TS-485- (571-13000-A)-A001 (REV-0)



**BHARAT HEAVY ELECTRICALS LIMITED
POWER SECTOR
PROJECT ENGINEERING MANAGEMENT
PROJECT ENGINEERING INSTITUTE BUILDING
SECTOR-16A, PLOT NO.-25, NOIDA, INDIA**



TITLE:
**1x800 MW TANGEDCO NORTH CHENNAI TPP–
(FGD SYSTEM)**

SPECIFICATION No: PE-TS-485- (571-13000-A)-A001 (REV-0)

SECTION

REV. 00

SHEET : 1 OF 2

CONTENTS

This Technical specification consists of two sections:

SECTION - I

SUB- SECTIONS	TITLE		Page No
Sub-Section-A	INTENT OF SPECIFICATION		2
Sub-Section-B	PROJECT INFORMATION		5
Sub-Section-C	TECHNICAL SPECIFICATIONS		9
	Sub Section-C1	SPECIFIC TECHNICAL REQUIREMENT	10
	Sub Section-C2	CUSTOMER TECHNICAL SPECIFICATION	30
	Sub Section-C3	TECHNICAL SPECIFICATION (ELECTRICAL PORTION)	51
	Sub Section-C4	TECHNICAL SPECIFICATION (C&I PORTION)	98
	Sub Section-C5	TECHNICAL SPECIFICATION (MATERIAL HANDLING PORTION)	200
Sub Section-D	STANDARD TECHNICAL SPECIFICATIONS		231
Sub Section-E	ANNEXURE-I	LIST OF MAKES OF SUB-VENDOR ITEMS	299
	ANNEXURE-II	MANDATORY SPARE LIST	314
	ANNEXURE-III	PAINTING & COLOUR SCHEME	317
	ANNEXURE-IV	LIST OF TOOLS & TACKLES	319
	ANNEXURE-V	MASTER DRAWING LIST WITH SCHEDULE OF SUBMISSION	320
	ANNEXURE-VI	FORMAT FOR OPERATION AND MAINTENANCE MANUAL	325
	ANNEXURE-VII	SITE STORAGE AND PRESERVATION	329



TITLE:
**1x800 MW TANGEDCO NORTH CHENNAI TPP–
(FGD SYSTEM)**

**SPECIFICATION No: PE-TS-485- (571-13000-
A)-A001 (REV-0)**

SECTION

REV. 00

SHEET : 2 OF 2

SECTION - II

SUB SECTIONS	TITLE	Page No
Sub Section-1	INSPECION AND TESTING WITH STANDARD QUALITY PLAN	346
Sub Section-2	LIST OF DOCUMENTS TO BE SUBMITTED WITH BID	350
Sub Section-3	COMPLIANCE CUM CONFIRMATION CERTIFICATE	351
Sub Section-4	PRE BID CLARIFICATION SCHEDULE	353
Sub Section-5	DEVIATION SHEET (COST OF WITHDRAWL)	354
Sub Section-6	GUARANTEE POWER CONSUMPTION	356
Sub Section-7	DRAWINGS	
	DRG TITLE	
a	PID FOR AIR COOLED CONDENSING UNIT	359
b	PID FOR UAF	360
c	ELECTRICAL LAYOUT FOR FGD CONTROL ROOM BUILDING	361



**1x800 MW TANGEDCO NORTH CHENNAI
TPP– (FGD SYSTEM)
TECHNICAL SPECIFICATIONS FOR
HVAC SYSTEM**

**SPECIFICATION No: PE-TS-485- (571-13000-
A)-A001 (REV-0)**

SECTION: I

REV. 00

SECTION - I



**1x800 MW TANGEDCO NORTH CHENNAI
TPP– (FGD SYSTEM)
INTENT OF SPECIFICATION**

**SPECIFICATION No: PE-TS-485- (571-13000-
A)-A001 (REV-0)**

SECTION : I

Sub Section: A

REV. 00

SHEET 1 OF 3

SECTION-I

SUB-SECTION-A

INTENT OF SPECIFICATION



**1x800 MW TANGEDCO NORTH CHENNAI
TPP– (FGD SYSTEM)
INTENT OF SPECIFICATION**

SPECIFICATION No: PE-TS-485- (571-13000-A)-A001 (REV-0)

SECTION : I

Sub Section: A

REV. 00

SHEET 2 OF 3

1.0 INTENT OF SPECIFICATION

- 1.1 The specification covers design, engineering, manufacture, supply / procurement, inspection and testing at vendor's / sub vendor's / manufacturer's works, painting, forwarding, proper packing and shipment and delivery at site, unloading, handling & transportation, storage, preservation , security / safety at site , Erection & Commissioning, minor civil & structural (as applicable) works as required on FOR site basis, mandatory spares, Performance and guarantee testing / demonstration testing and handing over to BHEL's customer of **HVAC SYSTEM** as per details in different sections / volumes of this specification and various pre award agreements for **1x800 MW TANGEDCO NORTH CHENNAI TPP– (FGD SYSTEM)**.
- 1.2 The contractor shall be responsible for providing all material, equipment & services, which are required to fulfil the intent of ensuring operability, maintainability, reliability and complete safety of the complete work covered under this specification, irrespective of whether it has been specifically listed herein or not. Omission of specific reference to any component / accessory necessary for proper performance of the equipment shall not relieve the contractor of the responsibility of providing such facilities to complete the supply, erection and commissioning, performance and guarantee/demonstration testing of **HVAC SYSTEM**.
- 1.3 It is not the intent to specify herein all the details of design and manufacture. However, the equipment shall conform in all respects to highest standards of design, engineering and workmanship and shall be capable of performing the required duties in a manner acceptable to purchaser who will interpret the meaning of drawings and specifications and shall be entitled to reject any work or material which in his judgement is not in full accordance herewith.
- 1.4 The extent of supply under the contract includes all items shown in the drawings, notwithstanding the fact that such items may have been omitted from the specification or schedules. Similarly, the extent of supply also includes all items mentioned in the specification and /or schedules, notwithstanding the fact that such items may have been omitted in the drawing. Similarly, the extent of supply also includes all terms required for completion of the system and not withstanding that they may have been omitted in drawings / specifications or schedules.
- 1.5 The general term and conditions, instructions to tenderers and other attachment referred to elsewhere are made part of the tender specification. The equipment materials and works covered by this specification is subject to compliance to all attachments referred to in the specification. The bidder shall be responsible for and governed by all requirements stipulated herein.
- 1.6 While all efforts have been made to make the specification requirement complete & unambiguous, it shall be bidders' responsibility to ask for missing information, ensure completeness of specification, to bring out any contradictory / conflicting requirement in different sections of the specification and within a section itself to the notice of BHEL and to seek any clarification on specification requirement in the format enclosed under



**1x800 MW TANGEDCO NORTH CHENNAI
TPP– (FGD SYSTEM)
INTENT OF SPECIFICATION**

SPECIFICATION No: PE-TS-485- (571-13000-A)-A001 (REV-0)

SECTION : I

Sub Section: A

REV. 00

SHEET 3 OF 3

section II of the specification **within 10 days of receipt of tender documents.** In absence of any such clarifications, in case of any contradictory requirement, the more stringent requirement as per interpretation of Purchaser / Customer shall prevail and shall be complied by the bidder without any commercial implication on account of the same. Further in case of any missing information in the specification not brought out by the prospective bidders as part of pre-bid clarification, the same shall be furnished by Purchaser/ Customer as and when brought to their notice either by the bidder or by purchaser/ customer themselves. However, such requirements shall be binding on the successful bidder without any commercial & delivery implication.

- 1.7 The bidder's offer shall not carry any sections like clarification, interpretations and /or assumptions.
- 1.8 Deviations, if any, should be very clearly brought out clause by clause along with cost of withdrawal in the format attached with GCC (Annexure-II Deviation sheet (Cost of withdraw), otherwise, it will be presumed that the vendor's offer is strictly in line with NIT specification.
- 1.9 In the event of any conflict between the requirements of two clauses of this specification documents or requirements of different codes and standards specified, Section - C shall prevail over section – D, however more stringent requirement as per the interpretation of the owner shall apply.
- 1.10 In case all above requirements are not complied with, the offer may be considered as incomplete and would become liable for rejection.
- 1.11 For definition of word like Contractor, bidder, supplier, vendor, Customer/ Purchaser Employer, consultant, please referred relevant clause of NIT.



**1x800 MW TANGEDCO NORTH CHENNAI
TPP– (FGD SYSTEM)
HVAC SYSTEM
PROJECT INFORMATION**

**SPECIFICATION No: PE-TS-485- (571-13000-
A)-A001 (REV-0)**

SECTION : I

Sub Section : B

REV. 00

**SECTION: I
SUB-SECTION: B
PROJECT INFORMATION**



ANNEX - 1.1
PROJECT INFORMATION

1.0	General		
1.1	Project Title	:	1 x 800 MW North Chennai Coal Based Super Critical Thermal Power Project Stage III.
1.2	Plant capacity	:	800 MW
1.3	Type of project	:	Brown field
1.4	Owner	:	Tamil Nadu Generation and Distribution Corporation Limited (TANGEDCO)
1.5	Plant site location	:	In the premises of North Chennai Thermal Power Station (NCTPS)
1.6	Location co-ordinates	:	80° 19' E to 80° 20' E Longitude 13° 13' N to 13° 18' N Latitude
1.7	Nearest Village	:	Ennore & Puzhuthivakkam Village
1.8	Nearest Town & City	:	Chennai (35 Km)
1.9	State Capital	:	Chennai (35 Km)
1.1	Nearest Railway Station	:	Athipattu Pudunagar (~ 5 Km) on Chennai – Vijayawada Line
1.11	Nearest Airport	:	Chennai (~ 60 Km)
1.12	Nearest Seaport	:	Ennore (~ 3 Km)
1.13	Nearest Road access	:	All weather road from Pattamandri on the Thiruvottiyur – Ponneri highway
2.0	Meteorological Condition		
2.1	Climate	:	Tropical, very dry and hot summer, dry and cold winter and good rain-fall in monsoon accompanied with strong wind
2.2	Site Elevation	:	(+) 10.0 Meter above Mean Sea Level
2.3	Ambient Temperature		
a.	Annual Maximum Mean Temperature	:	45 °C
b.	Annual Minimum Mean Temperature	:	15 °C
c.	Design ambient temperature	:	30 °C
2.4	Relative Humidity		
a.	Maximum	:	90%
b.	Minimum	:	36%
c.	Design	:	75%
2.5	Annual Rainfall		



	Maximum	:	2540 mm
	Average	:	1600 mm
	Minimum	:	1175 mm
2.6	Basic Design Wind Pressure	:	As per IS: 875 (Latest Edition)
2.7	Wind Speed	:	11.8 kmph (Avg), 50 m/s (max)
2.7	Seismic zone	:	Zone: III as defined in IS:1893-2002
2.8	Design ambient temperature for Electrical equipment	:	50 °C



ANNEX- 1.3

SERVICE WATER ANALYSIS

The Service water (make-up water) water quality is mentioned below:

Sr. No.	Parameter	Unit	Result
1	Temperature	°C	35
2	pH	-	7.5 – 8.2
3	LSI		0 -0.2
4	Alkalinity		< 100 PPM of Ca CO ₃
5	Hardness		< 80 PPM
6	Chloride		< 350 PPM
7	Sodium		< 170 PPM



**1x800 MW TANGEDCO NORTH CHENNAI
TPP– (FGD SYSTEM)
HVAC SYSTEM
TECHNICAL SPECIFICATION**

**SPECIFICATION No: PE-TS-485- (571-13000-
A)-A001 (REV-0)**

SECTION : I

Sub Section : C

REV. 00

SECTION: I

SUB SECTION: C

TECHNICAL SPECIFICATIONS



**1x800 MW TANGEDCO NORTH CHENNAI TPP--
(FGD SYSTEM)**

HVAC SYSTEM

SPECIFIC TECHNICAL REQUIREMENT

**SPECIFICATION No: PE-TS-485- (571-13000-
A)-A001 (REV-0)**

SECTION : I

SUB-SECTION : C 1

REV. 00

SHEET 1 OF 20

SECTION: I

SUB-SECTION: C 1

SPECIFIC TECHNICAL REQUIREMENT



**1x800 MW TANGEDCO NORTH CHENNAI TPP--
(FGD SYSTEM)
HVAC SYSTEM
SPECIFIC TECHNICAL REQUIREMENT**

SPECIFICATION No: PE-TS-485- (571-13000-A)-A001 (REV-0)

SECTION : I

SUB-SECTION : C 1

REV. 00

SHEET 2 OF 20

1. FUNCTION

The purpose of the system is to provide HVAC for different areas of 1x800 TANGEDCO NORTH CHENNAI TPP-FGD under the scope of this tender.

2. SYSTEM DESCRIPTION

Air Conditioning System

Air Conditioning system is to be provided for the following areas

- FGD Control Room at EL 8.7M with Air-Cooled Conditioning units (DX Type)
- Conference Room at EL 8.7M with non-ductable split Cassette Air Conditioner.
- C&I Staff room, Shift Incharge Room and O&M, Logs Record Room etc. at EL 3.7M of FGD Control Building shall be served with non-ductable Split Hi-wall air conditioner units.
- SO2 Analyser Room shall be served with non-ductable Split air conditioner units
- Any other smaller areas which are away from the Air-Cooled Air Conditioning units which may require air conditioning shall be served with non-ductable Split (Hi-wall/Cassette) air conditioner units as per requirement.

Ventilation System

Modular type UAF units of suitable capacity shall be provided for non-air-conditioned area of FGD control room building considering design philosophy for evaporative type ventilation system. Each UAF shall consist of 1 NO. (1x100%) of fans and 2 No. (2X100%) of Pump of suitable capacity. Ventilation is to be provided for following areas of FGD Control Room Building -

- Cable Vault Room at 0.0 M Elevation
- MCC Room at 3.7 M Elevation

The quantity of air exhausted shall be kept lower than the quantity of air supplied in such a way that a little overpressure is maintained inside the hall. This will reduce infiltration of outside hot and dusty air.

The ventilation philosophy in various areas shall be as follows:

S. No.	Area	Type of Ventilation
1	Non AC area of FGD Control Room Building	Modular type UAF units of suitable capacity (1x100%) with exhaust through gravity damper
2	General area like pump house, building etc.	Mechanical dry type ventilation through Combination of supply air fan & exhaust air fans



**1x800 MW TANGEDCO NORTH CHENNAI TPP–
(FGD SYSTEM)**

HVAC SYSTEM

SPECIFIC TECHNICAL REQUIREMENT

SPECIFICATION No: PE-TS-485- (571-13000-A)-A001 (REV-0)

SECTION : I

SUB-SECTION : C 1

REV. 00

SHEET 3 OF 20

3	MCCs and Switchgear room etc.	Mechanical dry type ventilation through combination of wall mounted axial flow Supply air fan & back draft dampers
4	Battery rooms & Oil rooms and fumes / door generates	Mechanical dry type ventilation through Combination of intake louvers & Exhaust air / roof extractor fans motors shall be flame proof
5	Toilet / pantry etc.	Propeller type exhaust air fan.

Any other building to be ventilated shall be provided by combination of wall mounted axial flow supply fans with gravity dampers or wall mounted axial flow exhaust fan with inlet louvers.

3. DESIGN CRITERIA:

System Design Criteria for HVAC:

The outside design conditions considered are as follows: -

	Summer	Monsoon	Winter
DBT(°C)	46.5	29.4	15.6
WBT(°C)	24.7	27.2	11.1

The inside design conditions to be maintained are as follows:

3.1. For Air Conditioning System

- 22°C ± 1°C & RH 50% ± 5% for Air Conditioned Areas of FGD Control Building**
- For winter heating load calculation, 50% of combined light load and eqpt. /Panel load as available in the room shall be considered.
- Fresh air requirement shall be minimum 1.5 air change per hour for control room areas or 35 m³ per hour per person whichever is higher. For other areas like office, Fresh air shall be considered as per ISHRAE
- A margin of 10% shall be considered for the capacity of equipment like Condensing Units, AHUs etc.
- Lighting load, minimum 2 W / Sq ft. or actual whichever is higher shall be considered
- The Occupancy shall be considered as One (1) person in 10 sq.m in general areas, One (1) person in 25 sq.m in control room, CER etc. or (actual).
- Necessary Heater and Humidifier shall be provided



1x800 MW TANGEDCO NORTH CHENNAI TPP–
(FGD SYSTEM)

HVAC SYSTEM

SPECIFIC TECHNICAL REQUIREMENT

SPECIFICATION No: PE-TS-485- (571-13000-A)-A001 (REV-0)

SECTION : I

SUB-SECTION : C 1

REV. 00

SHEET 4 OF 20

h) Air and water velocity for Air Conditioning System –

1.	Main Ducts	7.5 m/sec
2.	Branch Duct	6.0 m/sec
3.	Grill/Diffuser	2.0 m/sec
4.	Louvers for Air inlet	2.5 m/sec
5.	Water velocity in piping	2.5 m/sec
6.	Water velocity in piping (gravity flow/pump section)	1.5 m/sec
7.	AHU (face Velocity)	2.5 m/sec

- i) Air curtains to be provided at each entrance of FGD Control Room.
- j) For other design parameters refer relevant clauses of section C2-A, customer specifications.

3.2. For Ventilation System

a) Air Changes per Hour shall be as follows: -

- For all evaporative type ventilation system 8
- Electrical Room like M.C.C room, Switchgear Room 15
- Battery Room Areas 30
- General Areas 20
- Toilets 30

b) Inside temperature shall be kept 3° C below the design ambient temperature during summer for ventilated areas of Control Room Building.

c) In dry type forced (mechanical) Ventilation System where the ambient air is drawn and distributed inside the building/room and then exhausted, the average design condition inside the space to be ventilated is to be restricted 5°C higher than the ambient (outside) dry-bulb temperature. Higher of the air quantities obtained by the Air Change Method and Heat Load Calculation Method shall be selected.

d) All equipment shall be designed for continuous duty.

e) Air and water velocity –



**1x800 MW TANGEDCO NORTH CHENNAI TPP–
(FGD SYSTEM)**

HVAC SYSTEM

SPECIFIC TECHNICAL REQUIREMENT

SPECIFICATION No: PE-TS-485- (571-13000-A)-A001 (REV-0)

SECTION : I

SUB-SECTION : C 1

REV. 00

SHEET 5 OF 20

For Ventilation System –

1.	Main Ducts	12 m/sec
2.	Branch Duct	9.0 m/sec
3.	Grills	3.75 m/sec
4.	Backdraft dampers	6.0 m/sec
5.	Water velocity in piping	2.5 m/sec
6.	Water velocity in piping (gravity flow/pump section)	1.5 m/sec
7.	UAF (face velocity)	2.0 m/sec

- f) For other design parameters refer relevant clauses of section C2-A, customer specifications.

4. Layout Considerations

a) For Air Conditioning –

- I. Air cooled DX-type condensing units for AC Plant shall be placed at the roof of FGD control room building.
- II. The AHUs for this AC Plant would be located inside AHU room.

b) For Ventilation -

- I. UAF for Ventilation of FGD Control building shall be placed at the roof of FGD Control Room Building.
- II. The exhaust air from battery room shall be taken out through MS duct having epoxy coating and the air shall be released above roof of the building.

Note: (The locations given above are tentative and may change during detail engineering)



**1x800 MW TANGEDCO NORTH CHENNAI TPP–
(FGD SYSTEM)**

HVAC SYSTEM

SPECIFIC TECHNICAL REQUIREMENT

SPECIFICATION No: PE-TS-485- (571-13000-A)-A001 (REV-0)

SECTION : I

SUB-SECTION : C 1

REV. 00

SHEET 6 OF 20

5. EQUIPMENT AND SERVICES TO BE PROVIDED FOR AIR CONDITIONING SYSTEM

5.1 AIR COOLED CONDENSING UNIT (DX TYPE)

Refer to relevant clauses of section C2-A, customer specifications.

5.2 AIR HANDLING UNIT (AHU)

Refer to relevant clauses of section C2-A, customer specifications

5.3 HI-WALL SPLIT/CASSETTE AIR-CONDITIONERS

- a) Areas like C&I Staff room, Shift- Incharge Room and O&M, Logs Record Room etc. shall be provided with sufficient capacity of Non Ductable split Air conditioner with 100% redundancy.
- b) Air conditioning requirement of Conference Room shall be catered by Cassette Air conditioners of sufficient capacity with (100%) redundancy.
- c) For other details refer to relevant clauses of section C2-A, customer specifications

5.4 STRIP HEATER PACKAGE AND HUMIDIFICATION PACKAGE

- a) One common set of electrical strip heaters package of suitable capacity complete with contactor, air-stat, humidistat (room or mounted on strip heater control box), safety thermostat, heater box with insulation etc. for winter heating and monsoon reheat, mounted inside the AC plenum/duct for each AHU Room.
- b) One No. Pan humidification system comprising heater, humidistat, water tank, low level switch over flow, draining, make up connection, float valves etc for each AHU Room.
- c) Temp gauge, temp element, RH and temp sensor shall also be provided and the same shall be hooked with DDCMIS system.
- d) Refer to relevant clause of section C2-A, customer specifications

5.5 SHEET METAL WORK

- a) GSS supply and return air Ducting (as per IS-277) with 275 gms/sqm of zinc coating complete with vanes, damper, hangers / supports etc. Insulation of supply air AC duct and return air duct, piping, fitting etc. shall be provided as per relevant clause of customer technical specification.
- b) Supply air diffusers / grilles (Frame and Louvers of Diffuser/Grilles shall be of extruded aluminum of 1.2 mm thick section, duly powder coated) with volume control dampers. Return air Diffusers will have no Volume Control Damper.
- c) Other details shall be as per customer technical specification

5.6 INSULATION

Refer to relevant clauses of section C2-A, customer specifications.



**1x800 MW TANGEDCO NORTH CHENNAI TPP–
(FGD SYSTEM)**

HVAC SYSTEM

SPECIFIC TECHNICAL REQUIREMENT

SPECIFICATION No: PE-TS-485- (571-13000-A)-A001 (REV-0)

SECTION : I

SUB-SECTION : C 1

REV. 00

SHEET 7 OF 20

5.7 PIPING VALVES ETC.

Refer to relevant clauses of section C2-A, customer specifications

5.8 FRESH AIR FAN

Fresh air fan with pre-filter & fine filter in all AHU Rooms.

Other details shall be as per relevant clauses of section C2-A, customer specifications.

5.9 AIR CURTAINS

- I) Industrial Grade and fully automatically controlled (with On/Off control with door switch, Heat On/ Off control with room thermostat and Fan speed control with two phase thermostat). Air Curtains shall be designed in accordance to ISO 27327
- II) Self-supporting casing construction along with filter at inlet supply of air shall be provided.
- III) Air curtain shall be with Low noise.



**1x800 MW TANGEDCO NORTH CHENNAI TPP–
(FGD SYSTEM)**

HVAC SYSTEM

SPECIFIC TECHNICAL REQUIREMENT

SPECIFICATION No: PE-TS-485- (571-13000-A)-A001 (REV-0)

SECTION : I

SUB-SECTION : C 1

REV. 00

SHEET 8 OF 20

6 EQUIPMENT AND SERVICES TO BE PROVIDED FOR VENTILATION SYSTEM.:

6.1 UNITARY AIR FILTRATION

Each UAF shall comprise of –

- a) One number of centrifugal fan backward curved, DIDW type complete with as per customer specification clause no 5.3.2
- b) Two (2) No. of Horizontal centrifugal type pump (2x100%) for circulation of water as per customer specification clause 5.3.4.
- c) Other details shall be as per relevant clause of section C-2, Customer specification.

6.2 WALL MOUNTED AXIAL FLOW FAN

Refer to relevant clauses of section C2-A, customer specifications Electric drive motor with coupling if any, including motor brackets.

6.3 INSULATION

- a) Thermal insulation shall be provided for the duct exposed to sun / rain.
- b) Please also refer to other relevant clauses of Customer technical specification for detail construction of insulation.

6.4 FIRE DAMPAERS

- a) For fire damper refer to relevant clauses of section C2-A, customer specifications

7 SPECIFIC REQUIREMENTS: -

- a) The system shall be designed to maintain specified inside design conditions during peak summer under design outdoor condition.
- b) All ventilation system shall operate on 100% fresh air.
- c) The fire damper shall close the air flow inside the duct on receiving fire alarm signal from FPS. Also respective fan shall trip once the fire damper is closed.
- d) The name plate rating of all motors at 50deg C shall have at least 10% margin over the input power requirement of the driven equipment at rated duty point.
- e) RE / wall mounted fans shall be selected so as to have motor rating and wall / slab opening as under. Feeder suitable for following ratings only shall be provided by BHEL.

1.	Roof extractor units with 15 mmwc static pressure.		
	Capacity	Motor rating	Roof / Slab opening
a.	50,000 CMH	5.5 KW	1320 mm



**1x800 MW TANGEDCO NORTH CHENNAI TPP-
(FGD SYSTEM)**

HVAC SYSTEM

SPECIFIC TECHNICAL REQUIREMENT

SPECIFICATION No: PE-TS-485- (571-13000-A)-A001 (REV-0)

SECTION : I

SUB-SECTION : C 1

REV. 00

SHEET 9 OF 20

b.	40,000 CMH	5.5 KW	1320mm
c.	20,000 CMH	2.2 KW	1140mm
2	Axial flow supply fans with 30 mmwc static pressure.		
	Capacity	Motor rating	Wall opening
a.	10,000 CMH	2.2 KW	800mmx800mm
b.	7,500 CMH	1.5 KW	700mmx700mm
c.	6,000 CMH	1.1 KW	600mmx600mm
d.	4,000 CMH	0.75 KW	500mmx500mm
3	Axial flow supply fans with 20 mmwc static pressure.		
	Capacity	Motor rating	Wall opening
a.	10,000 CMH	1.5 KW	800mmx800mm
b.	7,500 CMH	1.1 KW	700mmx700mm
c.	6,000 CMH	1.1 KW	600mmx600mm
d.	4,000 CMH	0.75 KW	600mmx600mm
4	Axial flow exhaust fans (Bifurcated type) with 15 mmwc static pressure.		
	Capacity	Motor rating	Wall opening
a.	15,000 CMH	2.2 KW	900mmx900mm
b.	10,000 CMH	1.5 KW	800mmx800mm
c.	7,500 CMH	1.1 KW	700mmx700mm
d.	4,000 CMH	0.75 KW	600mmx600mm
e.	2,000 CMH	0.55 KW	500mmx500mm
5	Axial flow exhaust fans with 10 mmwc static pressure.		
	Capacity	Motor rating	Wall opening



**1x800 MW TANGEDCO NORTH CHENNAI TPP–
(FGD SYSTEM)**

HVAC SYSTEM

SPECIFIC TECHNICAL REQUIREMENT

SPECIFICATION No: PE-TS-485- (571-13000-A)-A001 (REV-0)

SECTION : I

SUB-SECTION : C 1

REV. 00

SHEET 10 OF 20

a.	15,000 CMH	1.1 KW	900mmx900mm
b.	10,000 CMH	0.75 KW	800mmx800mm
c.	7,500 CMH	0.55 KW	700mmx700mm
d.	6,000 CMH	0.55 KW	600mmx600mm
e.	4,000 CMH	0.55 KW	600mmx600mm
f.	2,000 CMH	0.37 KW	500mmx500mm
6	Exhaust fan (propeller type) with 5 mmwc static pressure.		
	Capacity	Motor rating	Wall opening
a.	1200 CMH	100 W	330 mm circular

8 CONTROL PHILOSOPHY

A common DCS based control system shall be provided for both Air conditioning and Ventilation System

Refer to clause of section, C-4 of specification.



**1x800 MW TANGEDCO NORTH CHENNAI TPP–
(FGD SYSTEM)**

HVAC SYSTEM

SPECIFIC TECHNICAL REQUIREMENT

**SPECIFICATION No: PE-TS-485- (571-13000-
A)-A001 (REV-0)**

SECTION : I

SUB-SECTION : C 1

REV. 00

SHEET 11 OF 20

9 ACCEPTANCE TEST

9.1 For Air Conditioning System

Room condition test shall consist of taking the reading of dry bulb and wet bulb temp at different locations points to be mutually decided at site in the areas which are air-conditioned by the respective system/plant. Room condition test shall be done after stabilization of the system. The dry and wet bulb temp shall be measured by sling psychrometer which will have accuracy of +/-0.5% with a least count of 0.5 degC. This will be carried out for 24 hrs continuously and readings will be taken every one-hour interval. Standby equipment should be changed over during these 24 hours. This test shall be carried out during summer during summer season when the dry bulb temp is generally high. Relative humidity shall be determined from psychometric chart.

Noise and Vibration measurement of various equipment shall be done at site

All shop testing at site as specified shall be carried out.

9.2 For Ventilation System

Air flow measurement of fans for ventilation system shall be done at supplier's works only

Noise and Vibration measurement of various equipment shall be done at site.

10 Operation and Maintenance Services

The bidder scope also covers the Operation and Maintenance (O&M) services for Preventive and Breakdown maintenance from the date of successful commissioning of HVAC System to end customer. However, actual date of start of O&M services shall be communicated to successful bidder by BHEL site personnel.

Bidder to note that the spares and consumables required for maintenance of the equipment during this O&M period shall be in bidder's scope of supply. Bidder shall use only genuine parts as mentioned in O&M Manual. Any damage or malfunction caused by the use of unauthentic parts or unqualified personnel shall be responsibility of bidder and as a consequence of above bidder is required to replenish the unauthorised part and abridge the qualified person without any commercial implication to BHEL.

O&M Services scope also covers all regular maintenance by certified and trained service engineers and supply of genuine parts and lubricants as per the original equipment manufacturer's recommendations in a pro-active manner.

For the purpose of Operation of HVAC System, One-day shall be considered as 24 hours i.e. 3 shifts of 8 hours each. The HVAC System (along with related accessories) shall be operated on Round-the-clock basis on all the days of the year including Sundays and Public Holidays



**1x800 MW TANGEDCO NORTH CHENNAI TPP–
(FGD SYSTEM)**

HVAC SYSTEM

SPECIFIC TECHNICAL REQUIREMENT

**SPECIFICATION No: PE-TS-485- (571-13000-
A)-A001 (REV-0)**

SECTION : I

SUB-SECTION : C 1

REV. 00

SHEET 12 OF 20

O & M Personnel should be acquainted with local language. Governmental / Statutory approval w.r.t. O&M service as applicable shall be in bidder's scope.

Total duration of the Operation and Maintenance services by Bidder can be increased or decreased as per requirement and payment in such case shall be made on pro-rata basis.

Depending on start of O&M services, there is a possibility that some period of O&M services and Warranty period may overlap. However, it is clarified that any maintenance required or any spare of HVAC System required to be replaced during Warranty period (as part of warranty clause requirement) shall not be made part of O&M Services. Bidder may take care of this fact while working out the prices of O&M services.

Wherever AC system has been written in O&M Service Specification, the same shall be deemed as complete HVAC System.

The vendor shall deploy following minimum manpower for Operation of HVAC System. One qualified and experienced AC operator per shift on "Round the Clock" basis throughout the year for all days of the year including Sundays & Public Holidays. There must be minimum 30 minutes overlapping between two shift operators to get familiarize with the status of HVAC System. Under normal circumstances one shift shall not be more than 8 hours.

One Helper per shift on " Round the Clock" basis throughout the year for all the days of the year including Sundays and Public Holidays. The helper shall assist the HVAC System Operator in day to day operation of HVAC System and accessories and shall assist him for keeping HVAC System equipment's in neat and tidy condition. Under normal circumstances one shift shall not be more than 8 hours

10.1 Responsibility of HVAC System Operator

- i. HVAC System operator shall be responsible for proper sequential operation of HVAC System (AC and Ventilation System) including operation of standby equipment in a predefined sequence and stopping the same (when necessary) as per the procedural practice. In case of any abnormality (like non availability of power supply at in-comer of HVAC System), he shall immediately report the matter to BHEL site Engineer for further action. Similarly, any malfunctioning in the system shall be immediately reported by him to BHEL site Engineer for suitable corrective action irrespective of time of occurrence of malfunctioning / abnormality in the system. A log book of all such outrages shall be maintained by HVAC system operator, which shall be shared with BHEL site engineer on periodic basis.



**1x800 MW TANGEDCO NORTH CHENNAI TPP–
(FGD SYSTEM)**

HVAC SYSTEM

SPECIFIC TECHNICAL REQUIREMENT

**SPECIFICATION No: PE-TS-485- (571-13000-
A)-A001 (REV-0)**

SECTION : I

SUB-SECTION : C 1

REV. 00

SHEET 13 OF 20

- ii. HVAC System operator shall take hourly readings of all the parameters of HVAC System / Equipment's including reading on main electrical panel of HVAC System. Temperature & RH readings inside all AC areas shall be taken at least once in a day. All the readings shall be recorded in a logbook register.

10.2 Responsibility of Helper.

- i. The HVAC System helper shall assist HVAC System operator for day to day smooth operation of HVAC System, like leaning of AHU filters and other filters etc. as and when required. He shall be responsible for keeping all the equipment's of HVAC System including DX Unit & AHU rooms in clean and tidy condition. He shall also carry out general cleaning of all AC equipment's including Electrical Panels (Part of AC System), AHU's etc. on regular basis.
- ii. The helper shall work under the control of HVAC System operator and shall always ensure that unusable junk materials are not allowed to be kept in HVAC System room or AHU rooms. Under such eventuality, he will report the matter to Plant Operator, who in turn will take suitable action including reporting the matter to BHEL site Engineer.

10.3 All the log book registers shall be arranged by vendor. Log book register duly paged and bounded will be maintained in good condition by vendor.

10.4 All the necessary tools and other materials, required for operation of HVAC System shall be kept by vendor under the control of HVAC System operator. Required testing instruments like refrigerant leak detector, Multi Meter (for Electrical portion of HVAC System), Sling psychrometer, Line Tester, Tool Kit, Torch etc. should also be always available with Plant Operator.

10.5 In case of any operator / helper being on leave, vendor shall immediately take advance action and provide substitution so that minimum manpower as indicated above is not reduced on any day. In case a particular shift duty A/C Operator or helper does not turn up due to any reasons, the earlier duty person shall continue to make sure that HVAC System never remains unattended.

11 Maintenance of HVAC System

- i. Maintenance work under scope of the vendor shall broadly include but in no way limited to the following:



**1x800 MW TANGEDCO NORTH CHENNAI TPP--
(FGD SYSTEM)**

HVAC SYSTEM

SPECIFIC TECHNICAL REQUIREMENT

SPECIFICATION No: PE-TS-485- (571-13000-A)-A001 (REV-0)

SECTION : I

SUB-SECTION : C 1

REV. 00

SHEET 14 OF 20

- a) Preventive maintenance of the plant.
- b) Servicing of the plant at regular interval including cleaning of AHU filters etc.
- c) Attending to complaints.
- d) Replacement of worn out or defective components
- e) Replacing of refrigerant gas and oil as and when required.

No consumable or any other items of HVAC system shall be arranged by Customer and no extra payment shall be made by customer in this regard.

- ii. Vendor shall be responsible at all time, during the entire period of contract for satisfactory performance of HVAC system (including accessories) with zero down time. During emergency or breakdown, vendor's Engineer along with related technicians shall be available immediately even though it may be beyond normal working hours or on public holidays till the HVAC System is restored back into normal satisfactory condition. Response time for attending breakdown complaints shall not exceed 2 hours.
- iii. Defective / worn out components shall be replaced only by genuine and original parts. OEM or its authorized dealer's invoice shall be submitted as proof of using genuine parts. All common spares required for HVAC system shall normally be kept available in the plant by the vendor. However, for critical spares, the same shall be made available in not more than 72 hours from the time of break-down requiring such spare.
- iv. Preventive Maintenance, servicing of HVAC System equipment's and accessories etc. shall be done by vendor in a planned manner in consultation with concerned customer's engineer. Preventive maintenance and service should be done as per the recommendations / guidelines of various OEMs
- v. Major servicing & over handling of equipment's like compressors, evaporators, condensers, pumps, AHU's, piping / ducting works, valves etc. shall be done by vendor once in a year.
- vi. Painting of all equipment's including base frames & accessories like piping, electrical panel boards etc. shall be done once in two years.
- vii. In case any repair/services of particular equipment of system like chiller unit is to be carried out by vendor through OEM (or their authorized dealer), all the arrangements including tools, O&M spares etc. shall be the total responsibility of vendor.



**1x800 MW TANGEDCO NORTH CHENNAI TPP–
(FGD SYSTEM)**

HVAC SYSTEM

SPECIFIC TECHNICAL REQUIREMENT

SPECIFICATION No: PE-TS-485- (571-13000-A)-A001 (REV-0)

SECTION : I

SUB-SECTION : C 1

REV. 00

SHEET 15 OF 20

- viii. Vendor shall arrange and maintain separate logbook register for services / maintenance of HVAC System. Record of work done for services/maintenance repairs etc. shall be recorded by vendor's engineer in this register. This register shall always be with updated records & shall be produced to customer's engineer on weekly basis or as & when required by him.
- ix. Vendor shall arrange and maintain sufficient stock of spares and consumable at site (HVAC room). Similarly, all necessary tools & instruments required for the purpose of servicing / maintenance / routine testing etc. shall also be arranged by vendor and should be available at site at all times.
- x. Repairs / servicing works shall normally be done by vendor at site up to maximum possible extent. However, in case any equipment or accessories is essentially required to be taken by vendor out of the plant premises for repairing / servicing, all necessary arrangements including to and fro transportation shall be the responsibility of vendor. Vendor shall also inform concerned customer's engineer for doing procedural formalities (like issue of gate pass etc.), prior to taking out the materials out of Plant premises.
- xi. In case bidder fails to supply the spares required for maintenance of the equipment, same shall be provided by BHEL at Bidders risk and cost.
- xii. Vendor shall be fully responsible for safety of his personal at all times. Vendor shall also be responsible for taking all safety precautions at all the times, especially during servicing / preventive maintenance and repairs of HVAC System equipment's etc.
- xiii. All the safety controls of AC Plant such as HP, LP, OP, Water pressure switch, inter locking etc. shall be positively checked at least once a month and same shall be recorded by vendor engineer
- xiv. Technicians & helpers engaged by the vendor shall wear uniform with nameplate for easy identification, while being within plant premises
- xv. Vendor's engineer shall be focal point for customer. He shall report to customer engineer on daily basis, for taking necessary instructions and to update the status of AC system
- xvi. If any damage to the equipment and its accessories has happened due to improper maintenance by bidder shall be recovered from the bidder.
- xvii. Bidder is to arrange all the safety gears like helmets, air plugs, safety shoes etc. during the maintenance for the O&M Staff.



**1x800 MW TANGEDCO NORTH CHENNAI TPP–
(FGD SYSTEM)**

HVAC SYSTEM

SPECIFIC TECHNICAL REQUIREMENT

**SPECIFICATION No: PE-TS-485- (571-13000-
A)-A001 (REV-0)**

SECTION : I

SUB-SECTION : C 1

REV. 00

SHEET 16 OF 20

12 GENERAL

- 1) Basis of design all calculations including heat load calculations for summer seasons, equipment selection criterion, layout drawings/ schemes/G.A. dwg and documents like data sheet/ technical particulars etc are subject to Customer approval during detail engineering stage.
- 2) Vendor to furnish characteristic curves for all major equipment offered indicating duty point during detailed engineering.
- 3) All drawings and documents shall be computer based.
- 4) All commissioning spares & consumables for trouble free operation till handing over, shall be provided.
- 5) Quality Requirements in the Technical Specification are indicating minimum requirements for inspection and testing. Vendor shall note that quality plan is subject to Customer & BHEL-approval during detail engineering stage. Standard QP format is enclosed in the technical specification.
- 6) Indicative list of makes is enclosed as per Annexure-I however this equipment / items shall be subject to Customer & BHEL approval during detail engineering Stage.
- 7) Inserts or any support arrangement for fixing ducting, fans, piping etc. shall not be provided by BHEL. Necessary supports may be taken from nearest structure / walls / roofs / floors etc. by Vendor.
- 8) Fixing frame works for diffusers and grilles in the scope of Vendor.
- 9) Anchor fastener shall be used by vendor for fixing duct pipes etc. wherever applicable.
- 10) Necessary supports and structures / frames etc. as required for supporting the duct / piping / equipment etc. as lump-sum basis is in the scope of Vendor and no unit rates shall be applicable for these items.
- 11) Drain piping within room up to the drain point to be provided by the Vendor.
- 12) Vendor to furnish schedule of power and control cables. Vendor to furnish cable termination details interconnection drawings etc. during detail engineering stage.
- 13) The tools and machine required for erection of equipment shall be arranged by Vendor.
- 14) Tools & tackles as required for regular maintenance shall be supplied by Vendor.



**1x800 MW TANGEDCO NORTH CHENNAI TPP–
(FGD SYSTEM)**

HVAC SYSTEM

SPECIFIC TECHNICAL REQUIREMENT

SPECIFICATION No: PE-TS-485- (571-13000-A)-A001 (REV-0)

SECTION : I

SUB-SECTION : C 1

REV. 00

SHEET 17 OF 20

- 15) Instruments required for performance testing of various equipment / system of the package shall be arranged by Vendor at site.
- 16) Instrument for testing shall be calibrated by Air-conditioning plant supplier before taking up testing.
- 17) Pressure gauges shall have provision for air venting. Three way valves shall be used which shall have air venting provision.
- 18) Matching sockets / stubs (weld type) for flow switches and other instruments shall be supplied (as per attached instrumentation installation diagram)
- 19) Bidders shall guarantee to maintain specified inside design conditions during summer, monsoon and winter and also even if the internal equipment load varies from 100% to 25%.
- 20) The guarantee tests shall cover but not limited to the following rated parameters for smooth operation of air conditioning and ventilation system.
 - Performance test of the Air conditioning system shall be carried out at site after proper installation. The site test shall include performance testing of equipment for minimum 72 continuous hours in summer or monsoon and minimum 24 continuous hours in winter. Bidder, as may be required to carry out site tests shall arrange all instruments, tools etc.
 - All calibrated instruments to be used for the tests at manufacturer's works/site shall be arranged by the bidder. Any Electrical/C&I items and accessories like junction box, glands etc. shall be included by vendor in his scope.
- 21) For group of motorized fire damper / 3 Way valve actuators / motorised valves, single phase power supply shall be provided by BHEL in AHU room. Suitable transformer shall be provided by bidder (if required) to derive the power input. Further distribution through junction box / distribution board shall be in vendor scope and shall have provision for isolation of individual fire damper/ valves.
- 22) Tender drawings enclosed form the part of specification and the bidder shall check the space requirements for installing the equipment as per the specification and layout requirements given in the specifications.
- 23) Bidder should suitably group the signals coming from various instruments etc. & the same shall terminate in local JB, from Local JB common cable to DCS / panel / MCC shall be selected. Any Electrical / C&I item and accessories like junction box, glands etc. shall be included by vendor in his scope.



**1x800 MW TANGEDCO NORTH CHENNAI TPP–
(FGD SYSTEM)**

HVAC SYSTEM

SPECIFIC TECHNICAL REQUIREMENT

SPECIFICATION No: PE-TS-485- (571-13000-A)-A001 (REV-0)

SECTION : I

SUB-SECTION : C 1

REV. 00

SHEET 18 OF 20

- 24) In the event of any conflict between the requirements of two clauses of this specification documents or requirements of different codes and standards specified, the more stringent requirement as per the interpretation of the owner shall apply.
- 25) Bidder to note that BHEL reserve the right for drg/doc submission through web based Document Management System. Bidder would be provided access to the DMS for drg/doc approval and adequate training for the same. Bidder to ensure proper internet connectivity at their end.
- 26) Quality requirements in the Technical specification are minimum requirements for inspection and testing. Vendor to note that quality plans are subject to Customer approval during detail engineering stage. Standard QP format is enclosed in the technical specification.
- 27) Sealing of duct opening, grouting of foundation / foundation bolts etc. including special type of grouting like GPX2 etc. are in the scope of Air-conditioning system vendor.
- 28) Flat, platform type RCC / PCC foundation shall be provided for installing Chiller/ PUMP, AHU and FAN etc. Vendor shall fix the equipment using anchor fasteners to secure the equipment obtain parameters related to vibration and noise.
- 29) Bidder to note that the P&ID shows only the bare minimum requirement of valves and instruments. Any instrumentation & valves as required for the completion of the system in line with technical specification shall be provided by bidder during detailed engineering without any commercial implication.
- 30) Supplier to furnish drawings/ documents as per the dwg. / documents distribution as per project requirement.
- 31) Each motor terminal box shall be provided with cable gland and lugs for the size and type of power and control cable of respective motor.
- 32) All electrical equipment shall be suitable for the power supply fault levels and other climatic conditions indicated in project information / synopsis / specifications enclosed.
- 33) The bidder's proposal shall be for equipment in accordance with the tech. Specification.
- 34) The bidder shall furnish complete tech. Particulars in data sheet and schedules as specified elsewhere in the specification during detail engineering
- 35) All openings required in brick wall for installing the axial supply and exhaust fans, propeller fans, duct opening, louvers and damper openings etc shall be done by BHEL as per opening sizes indicated under clause number 7. Any opening requirement on account of change in size of equipment over and above the opening size indicated under clause number 7, same shall



**1x800 MW TANGEDCO NORTH CHENNAI TPP–
(FGD SYSTEM)**

HVAC SYSTEM

SPECIFIC TECHNICAL REQUIREMENT

SPECIFICATION No: PE-TS-485- (571-13000-A)-A001 (REV-0)

SECTION : I

SUB-SECTION : C 1

REV. 00

SHEET 19 OF 20

be done by vendor along with finishing of opening and painting as per finished wall. Grouting of fans along with anchor fasteners shall be done by vendor. The openings shall be finished properly. In case openings are done once the wall have been painted, repainting, to match with the existing wall paint shall also be done by the vendor. Sealing of duct opening, grouting of foundation / foundation bolts etc. including special type of grouting like GPX2 etc. are in the scope of Ventilation system vendor.

- 36) All codes and standards shall be as per contract specifications

13 EXCLUSIONS

Items of works listed below are excluded from scope of the HVAC system supplier.

- a) Construction of AHU room, foundations for HVAC equipment's.
- b) False ceiling, drop ceiling.
- c) Slab cut out for running ducts, pipes, cables, grilles/dampers. Underground masonry trenches and masonry risers. However minor civil work like making opening to suit / finishing of opening, sealing of duct opening, grouting of foundation bolts including special type of grouting like GPX2 etc. are in the scope of HVAC system vendor.
- d) Provision of drain traps / points,
- e) For Electrical scope, refer Electrical scope matrix sheet.

14 Codes and Standards

Design, manufacture, inspection and testing of the equipment covered by the specification shall unless otherwise specified conform to the latest edition of the standards and codes including all addenda mentioned below:

IS-659: Safety code for air-conditioning

IS-660: Safety code for mechanical refrigeration

ASHRAE-23: Standard method of testing and rating [67 Standards] air conditioner.

ARI-450-6: Standards for water cooled refrigerant Condenser.

ASME Sec. VII: Unfired pressure vessels

IS-4503: Shell and tube type heat exchanger.

ASHRAE 22-72: Method of testing for rating water cooled refrigerant condenser.

ASHRAE-15-2007: Safe Standard for Refrigeration System

ASHRAE-30-1995: Method of testing liquid chilling packages

ANSI-8-31.5: Refrigeration piping.



**1x800 MW TANGEDCO NORTH CHENNAI TPP–
(FGD SYSTEM)**

HVAC SYSTEM

SPECIFIC TECHNICAL REQUIREMENT

SPECIFICATION No: PE-TS-485- (571-13000-A)-A001 (REV-0)

SECTION : I

SUB-SECTION : C 1

REV. 00

SHEET 20 OF 20

ANSI-8-9.: Safety code for mechanical refrigeration.

AR1-410 : Standard for air cooling and air heating coils.

AR1-210: Standard for unitary air conditioning equipment.

IS-3588: Specification for electrical axial flow fans.

AMCA-210: Methods of performance test for fans.

BS-2831: Methods of test for air filters used in AC and general ventilation.

IS-4671: Expanded polystyrene for thermal insulation purpose.

IS-702: Industrial bitumen

IS-1239: Heavy class Pipes for sizes up to 150 mm dia.

IS-8188: For Water conditioning

IS-325: 3 phase induction motors

IS-4029: Guide line for testing 3 phase induction motor

IS-210: Specification grey iron casting

IS-2062: Structural steel

AMCA - Bulletin: Standard code of testing centrifugal and axial No. 210 flow fans

IS-2825: Code of practice for welding mild steel

IS-2676: Dimensions for wrought aluminium and aluminium alloy sheets and strips.

ASHRAE Code: For various filter

ASHRAE-62-2004: Ventilation rates

IS-655: Specification for metal air ducts

Pump design and testing should correspond to the procedure mentioned in IS-1520



**1x800 MW TANGEDCO NORTH CHENNAI
TPP– (FGD SYSTEM)
HVAC SYSTEM
TECHNICAL SPECIFICATION
(ELECTRICAL PORTION)**

SPECIFICATION No: PE-TS-485- (571-13000-A)-A001 (REV-0)

SECTION : I

SUB-SECTION : C-2

REV. 00

**SECTION: I
SUB-SECTION: C-2
CUSTOMER SPECIFICATION**



VOLUME – II

SUB-SECTION 2.7

AIR CONDITIONING & VENTILATION SYSTEM

1.0.0 INTRODUCTION

This section covers minimum requirements for design, engineering, fabrication, manufacture & assembly, inspection, erection, testing and commissioning of complete air conditioning and ventilation system for FGD plant buildings, equipment and entire FGD area.

2.0.0 CODES AND STANDARDS

Design, Manufacture, inspection and testing of equipment covered under this specification for HVAC system shall comply with all currently applicable statutes, regulations and safety codes in the locality where the equipment is to be installed. The equipment shall also confirm the latest applicable Indian/British/American standards. Some of the applicable standards are listed below.

ASHRAE	
ISHRAE	
IS 325	Three phase induction motors
IS 655	Metal Air ducts
IS 2312	Propeller type AC ventilation fans
IS 3588	Electric axial fans
IS 4894	Centrifugal fans
UL 555	Fire dampers

3.0.0 AREAS TO BE AIR CONDITIONED

3.1.0 The areas to be air-conditioned shall be as follows:

- Air cooled condensing units (Dx type) type air conditioners with AHU of suitable capacity with 100% redundancy (as per approved heat load calculation) shall be provided for FGD Control room building.
- Cassette and Hi-wall Air-conditioners for Other auxiliary control room /control room buildings is also covered in the scope of Bidder.

4.0.0 AREAS TO BE VENTILATED

- Modular type UAF units of suitable capacity (1x100%) shall be provided for non-air-conditioned area of FGD control room building considering design philosophy for evaporative type ventilation system. All non-air-conditioned area of FGD control room building (cable gallery & MCC room shall be positively ventilated and exhaust shall be through gravity damper.
- Mechanical Ventilation (using Roof extractors/ Supply and/or Exhaust fans) shall be provided for various other areas/buildings in the scope of bidder as under:
 - Grinding system building
 - Gypsum dewatering building
 - Recirculation pump & Oxidation blower/compressor building.



- (iii) Toilets in above building (i) & (ii). Any other area not listed above but covered in the scope of Bidder.
- (iv) For other miscellaneous areas/ buildings not listed above but covered in the scope of Bidder, mechanical type ventilation system using Supply and/or exhaust air fans/ roof exhausters shall be provided.

4.2.0 All non-air-conditioned areas covered under this package shall be ventilated by a combination of supply/exhaust fans and fresh air in-take back draft louvers as detailed below

Sl. No.	Area	Type of Ventilation System
(i)	General area like pump house, building etc.	Combination of supply air fan & exhaust air fans
(ii)	MCCs and Switchgear room etc.	Supply air fan & back draft dampers
(iii)	Battery rooms & Oil rooms and fumes / door generates	Combination of intake louvers & Exhaust air / roof extractor fans motors shall be flame proof
(iv)	Toilet / pantry etc.	Propeller type exhaust air fan.

5.0.0 DESIGN CRITERIA

5.1.0 Outdoor Design Conditions:

Season	Dry Bulb Temp. (°C)	Wet Bulb Temp. (°C)
Summer	46.5	24.7
Winter	15.6	11.1
Monsoon	29.4	27.2

I. Air-conditioning system

a) Indoor Design Conditions:

Dry bulb temperature : 22°C ± 1°C

Relative humidity : 50 ± 10%.

- b) For fresh air quantity, number of air changes per hour shall be min.1.5 or 35 CMH/person or suitable to maintain over pressure of 2 mmWC, whichever is higher.
- c) Lighting load - 2 watts/ft² or actual whichever is higher shall be considered for heat load calculations.
- d) The occupancy for general area shall be minimum one person per 10m².In the control rooms, control equipment rooms the occupancy shall be considered one person per 25m² (Minimum) or part thereof.



- e) Minimum design margin of 12.5% on sensible heat, 10% on latent heat and 10% margins for overall heat respectively shall be considered while calculating heat load.
- f) Heat dissipation of panels shall be considered in the equipment sizing calculation for summer and monsoon season. 50% of equipment load shall be considered for winter load calculations.
- g) To reduce the air conditioning load, the exposed roof slabs (Including beams and column etc.) of air conditioning control room shall be insulated with 50 mm thickness fiber glass insulation of density 48 kg/m³ finished with 26 swg aluminum cladding.
- h) Noise level within the air conditioned space shall be restricted to 35-45 NC level with suitable acoustic attenuation (with duct silencer / acoustic insulation etc.).

II. Ventilation system

- a) The ventilation system shall be designed to maintain the dry bulb temperature not exceeding 5⁰C above design ambient summer temperature (heat load basis) or based on number of air changes per hour, whichever is higher.
- b) No. of air changes per for switchgear room as follows,

Area description	Air changes/hour
Switchgear/MCC room	15
Pump house	20
Toilets	30
Battery room/Areas where gaseous fumes/vapors are generated	30

- c) All the equipment of ventilation system shall be designed for continuous duty for continuous operation of 24 hours a day, all indoor and outdoor installed units.
- d) A minimum 10% margin shall be considered while sizing the equipment capacity.
- e) All ventilation system shall operate on 100% fresh air. All mechanically ventilated areas shall be positively ventilated by means of supply air fans fitted with filters and/or gravity operated back draft dampers and exhaust fans. MCC room, electrical equipment room etc. shall necessarily be pressurized condition. Supply air fan catering for electrical areas shall be provided with fine filters and for other areas, supply air fans shall be provided with pre-filters only.
- f) Supply air fans, exhaust air fans for ventilations of each area shall be provided with local starter panels.
- g) The openings required for fan fixing and duct crossing shall be 50 mm larger than the fan fixing frame and duct size respectively including insulation.



5.2.0 Equipment Description - Air Conditioning System

Air-Cooled D-X type

Type	: Air cooled scroll type
Vibration isolators	: Steel spring / Neoprene rubber cushy foot type with isolation efficiency not less than 85%.
Compressor	
Type	: The Compressor shall be scroll, serviceable, either hermetic type or semi-hermetic type with automatic capacity control (minimum 3 steps).
Type of drive	: Motor driven, direct or through V-belt.
Refrigerant	: The refrigerant shall be R-134a/ R-410AIR-407C or any other environment friendly refrigerant.
Accessories	: High/Low pressure cutouts, oil pressure switches, relief valves, pressure gauges at each stage, lube oil and control oil pressure gauges, suction & discharge stop valves, Muffler, Crank case heaters, oil filters, magnetic oil separators, temperature indicators for lube oil/heaters, oil level indicators, safety thermostat for crank case heater, vibration isolators, etc.
Motor Rating	: 10% more than the power required by the compressor at 50 deg C design ambient temperature.
Capacity	: Minimum capacity shall be suitable for the identified/selected at evaporating temperature and condensing temperature and shall be indicated

5.2.1 Air Handling Unit (AHU)

5.2.1.1 Each AHU shall consist of casing, fan impeller section, cooling coil section, damper section, steel frame with anti-vibration mountings (AVMs) having minimum 85% vibration dampening efficiency and flame retardant, water proof neoprene impregnated flexible connection on fan discharge. Isolation dampers at the suction and discharge of each AHU shall be provided, in case return air duct is directly connected to AHU. However, in case AHU room is used for return air, isolation dampers are required to be provided only at AHU discharge of each AHU. Pre-filter at the suction and fine (micro-vee type) and absolute (HEPA type) filters (wherever applicable) at the discharge of each individual AHU, and heater section in the common discharge of AHUs shall be provided.

5.2.1.2 The casing of AHUs shall be of double skin construction. Double skin sandwich panels (inside and outside) shall be fabricated using minimum 0.63 mm (24g) galvanized steel sheet (thickness of galvanization as per manufacturer's standard), with 25mm thick polyurethane foam insulation of minimum 38 Kg/Cum density in between. Suitable reinforcements shall be provided to give structural strength to prevent any deformation/buckling.



- 5.2.1.3 Sloping condensate drain pan shall be made of minimum 1.2 mm thick Stainless Sheet Steel. It shall be isolated from bottom floor panel through 25mm thick heavy duty treated for Fire (TF) quality expanded polystyrene or polyurethane foam. Drain pan shall extend beyond the coil.
- 5.2.1.4 Cooling coil (min. 4 row deep) shall be made of seamless copper tubes with aluminum fins firmly bonded to copper tubes and shall be provided with suitable drains and vents connections.
- 5.2.1.5 All filter plenum shall be provided with a walking platform inside the plenum chamber for filter cleaning purpose. Inspection door shall be provided at the plenum chamber and a removable type ladder shall be attached to plenum.

5.2.1.6 Centrifugal fan for AHU

- a) Fan Type : Double Width Double Inlet (DWDI) Centrifugal Type
- b) Fan impeller : Backward curved blades
- c) Casing material : GI /Mild steel with minimum thickness of 3 mm.
- d) Impeller material : Carbon steel
- e) Shaft : EN 8 Steel
- f) Fan bearings : Self aligning type, permanently lubricated, heavy duty with a design life of 10,000 operating hours.
- g) Critical speed : First critical speed of rotating assembly shall be at least 25% above the operating speed.
- h) Drive : Motor driven with removable belt guard. Motor driven with removable belt guard. Motor rating (at 50 deg.C ambient) shall be atleast fifteen percent (15%) above the maximum load demand of drives at the design duty point.
- i) Fans : For AHUs of capacity 50,000 CMH and above, Bidder may offer two (2) Nos. centrifugal fans of equal capacity for each AHU provided all such AHUs are accommodated within the space identified by the Employer.

5.2.1.7 Mixing Box:

Mixing box shall be complete with fresh and return air dampers. Mixing box shall be provided whenever the return air is ducted back to the AHU. Further, wherever return air is led back directly to AHU room, no mixing box is required.

5.2.1.8 Pan Humidifier:

Pan humidifier shall be made of 22 gauge SS 304 tank, duly insulated with 25 mm thick resin bonded fiber glass insulation (min. 24 Kg/m³ density) with 0.5 mm GSS cladding. The humidifier shall be complete with stainless steel immersion heaters, safety thermostat, float valve with stainless steel ball, sight glass, overflow and drain connections, steam outlet nozzle and float switch. Step controller shall be provided for switching on/off heater banks as per system requirement.



5.2.2 HI-Wall Split/Cassette Air-Conditioners

5.2.2.1 Hi-wall Split/cassette air conditioners shall in general consists of the following:

- i) Casing
- ii) Hermetically sealed rotary/scroll Compressor
- iii) Condenser and condenser cooling fan
- iv) Evaporator along with fan
- v) Cooling coil
- vi) Filters
- vii) Piping, valves, refrigerant strainer, etc.
- viii) Controls, instruments, control panel/starter panels.
- ix) Vibration isolator pads, etc as required.
- x) Refrigerant as per manufacturer practice.

5.2.2.2 Indoor unit of Ceiling Mounted Cassette Type Unit (Multi Flow Type):

The housing of the unit shall be powder coated galvanized steel. All the indoor units regardless of their difference in capacity should have same decorative panel size for harmonious aesthetic point of view.

Unit shall have four way supply air grills on sides and return air grill in center. Each unit shall have high lift drain pump and very low operating sound.

5.2.3 Split/Packaged Air Conditioners

5.2.3.1 Split/package air conditioners shall in general consist of following:

- i) Casing
- ii) Compressor
- iii) Condenser
- iv) Evaporator and condenser cooling fan
- v) Cooling Coil
- vi) Filters
- vii) Piping, Valves, refrigerant strainer etc.
- viii) Control, instruments, control panel/starter panels.
- ix) Vibration isolator pads, ducting (if applicable) etc. as required.

5.3.0 Equipment Description -Ventilation System

5.3.1 Unitary Air Filtration

5.3.1.1 Each modular unitary air filtration shall consist of Casing, Tanks, Fans, Distribution plates, Moisture eliminator and water repellent type nylon filter with frame and support, Header and standpipe with support, Spray and flooding type nozzle. Screen type suction strainer, Pumps, Necessary controls & Instrumentation, and all other required accessories.

5.3.1.2 The housing/ casing of air washer unit shall be double skin construction. Double skin panels shall be made of 22G galvanized sheet on outer side and 20G galvanized sheet inside with 25mm thick polyurethane foam insulation of minimum 38 kg/cum density. Frame work for section shall be joined together with soft rubber gasket in between to make the joints air tight. The entire fan section shall be mounted on rolled formed GSS channel frame work.



- 5.3.1.3 The unitary air filtration tank shall be fabricated from MS plate of minimum 6 mm thick and inside and outside surface of the tank shall be spray galvanized (**minimum 60 microns DFT**). Minimum depth of the tank shall be 600 mm. Tank construction shall be such that the suction screen can be replaced while the unit is operating. Tank shall be provided with overflow, drain with valve, float valve makeup connection with a gate valve backup, quick fill connection with globe valve etc. The overflow pipe shall be connected to drain pipe after isolating valve on drain pipe.
- 5.3.1.4 The distribution plate shall be fabricated out of 18G galvanized steel sheets & galvanized steel angle supports with minimum 50% free area.
- 5.3.1.5 Unitary air filtration shall be one-bank construction. All header and stand pipes shall be galvanized. Cat walks of suitable width shall be provided for maintenance of nozzle, filter etc.
- 5.3.1.6 The spray nozzles shall be of brass or bronze with chrome plating and shall be self-cleaning type. The nozzle shall be designed to produce fine atomized spray and shall be properly spaced to give a uniform coverage of the air washer section. The pressure drop through the nozzle should be in the range of 1.4 to 2.4 Kg/cm².
- 5.3.1.7 The eliminator plates shall be of 24G thick GS sheets class 275 or from 100% virgin PVC of minimum finished thickness of 2 mm. The eliminator section made of GSS shall have minimum six bends. The PVC eliminators shall be UV stabilized using Titanium di-oxide and shall withstand the weathering test as per IS: 4892 for 500 hrs. Type test report of the compound testing carried out in any reputed laboratory shall be submitted for approval. All supports, tie rods and space bar shall be of either galvanized steel or PVC construction and shall be complete with suitable drip tray and drain pipe.
- 5.3.1.8 Air tight inspection doors of suitable size shall be provided for suction chamber. Spray chamber and fan suction for easy accessibility and maintenance and a water marine light to be provided for each unitary air filtration.
- 5.3.1.9 Suitable number of brass screen shall be provided in the air washer tank to arrest the dirt entering the circulating water pump suction. Suitable GI grid shall be used inside the screen for reinforcement.
- 5.3.1.10 The specification for centrifugal fans shall generally be as indicated below. However, the fan shall be of DIDW type for UAF unit.
- 5.3.1.11 Saturation efficiency of Unitary Air Filtration units shall be minimum 60%.

5.3.2 Centrifugal Fan

- 5.3.2.1 The casing shall be of welded construction fabricated with heavy gauge galvanized sheet steel or MS sheet with spray galvanization (minimum 60 micron OFT). The minimum thickness of casing shall be 3 mm. It shall be rigidly reinforced and supported by structural angles. The seams shall be permanently sealed air-tight. Split casings shall be provided on larger sizes of fans. Casing drain with valves shall be provided wherever required.

The impeller shall have die-formed backward-curved blades tie welded to the rim and back plate to have a non overloading characteristic of the fan. Rim shall be spun to have a smooth contour. If required intermediate stiffening rings shall be provided. Shaft sleeves shall be furnished wherever required. The impeller, pulley and shaft sleeves shall be secured to the shaft by key and/or nuts.



- 5.3.2.2 The bearing shall be self-aligning, heavy duty ball, roller or sleeve bearing. They shall be adequately supported. They shall be easily accessible and lubricated properly from outside.
- 5.3.2.3 Inlet guard shall be spun to have a smooth contour. Inlet screen, if provided, shall be of galvanized wire mesh of 25 mm square.
- 5.3.2.4 Base plate with necessary number of spring type vibration isolators or ribbed neoprene rubber pad or cushy foot mounting shall be provided. The vibration isolators should have a minimum of 85% efficiency.
- 5.3.2.5 The first critical speed of the rotating assembly shall be at least 25% above the opening speed.
- 5.3.2.6 The fans shall be provided with V-belts and sheaves. All belts shall be sized for 150% rated HP. All V-belt shall be equipped with removable belt guards that do not impede the air flow to the fan inlet. There shall be a minimum of two belts per drive. Motor rating (at 50 deg C ambient) shall be at least fifteen percent (15%) above the maximum load demand of drives at the design duty point.

5.3.3 Roof Ventilators (If applicable)

- 5.3.3.1 The roof extractors shall be "COWL" type.
- 5.3.3.2 Impeller shall be of axial flow type, cast Aluminum in one piece and dynamically balanced. Casing shall be heavy gauge sheet steel construction of 3 mm thick for impeller up to 750 mm diameter and 5 mm for fans with impeller of diameter 750 and above. In casing, access door with locking arrangement be provided.
- 5.3.3.3 The cowl shall be designed for weather protection of the fan also inside of the roof on which the extractor is installed. Galvanized bird screen of 15 mm Square be provided with the cowl. All accessories, steel supports as required will be provided.
- 5.3.3.4 The speed of the fan shall be limited as per limitation given above for axial fans.
- 5.3.3.5 All accessories rain protection exhaust hood, transformation piece, vibration isolators, steel supports vibration isolators, bird screen, etc. as required shall be provided.
- 5.3.3.6 The vibration level for fans shall be as per ISO: 14694.

5.3.4 Centrifugal Pumps

- a) Type : Horizontal Centrifugal, Axial or radial split type casing pump or end suction, top discharge horizontal centrifugal pump
- b) Impeller : Closed type
- c) Material of Construction
- i) Casing : 2% Ni Cast Iron IS: 210 Gr. FG-260
- ii) Impeller : Bronze IS: 318 Gr-2
- iii) Wearing rings : Bronze
- iv) Shaft : SS 316



- v) Shaft sleeve : SS 316
- vi) Lantern ring : Brass / Bronze
- vii) Packing : Asbestos free
- viii) Base Plate : Carbon steel as per IS:2 062
- ix) Speed : Maximum 1500 rpm

5.3.5 Axial Fans

5.3.5.1 These fans shall have fixed/variable pitch cast aluminum blades of aero foil design.

5.3.5.2 The fan casing shall be of heavy gauge sheet steel construction.

5.3.5.3 Necessary rain protection cowl, inlet and outlet cones, bird protection screen, adjustable damper, vibration isolators, back draft dampers etc. shall be provided.

5.3.5.4 The speed of the fan shall not exceed 960 rpm for fan with impeller diameter above 450 mm and 1400 rpm for fan with impeller diameter 450 mm or less. However for fans having static pressure of 30 mm WC or above the speed of the fan shall not exceed 1440 rpm for fan with impeller diameter of above 450 mm and 2800 rpm for fan with impeller diameter of 450 mm or less. The first critical speed of rotating assembly shall be at least 25% above the operating speed.

5.3.5.5 All other accessories like supporting structure etc. as required shall be provided.

5.3.5.6 Fans of capacity 1000 cum/hr & lower shall be of propeller exhaust type.

6.0.0 BALANCE EQUIPMENT SPECIFICATION

6.1.0 Material of Construction for Piping & Fittings

- a) Piping for Chilled : Heavy grade-IS:1239 or Equivalent upto150 NB and Condenser and IS:3589 or Equivalent for pipes beyond 200 water lines NB
- b) Refrigerant piping : Seamless steel tubes conforming heavy grade IS:1239 or copper tubes as per IS:2501 (copper material as per IS:191 hard copper grade).
- c) Drain piping : Same as (a) above & galvanized as per IS: 4736.
- c) Fittings :
 - 1) The steel fittings shall conform to ASTM A234 Gr. WPB and dimensional standard to ANSI B 16.9/ANSI B16.11 or equivalent for sizes 65 NB and above.
 - 2) For sizes 50 NB and below, the material shall conform to ASTM A-105.



- 3) All steel flanges shall be of slip on type and shall conform to ANSI 16.5
- 4) For pipe sizes above 350 NB, fabricated fittings of adequate thickness may be used. The bend radius in case of miter bends shall be minimum 1.5 times the nominal pipe diameter and angle between two adjacent sections shall not be more than 22.5 deg and shall be as per BS:2633/BS:534.
- 5) Fittings, flanges and pipe joints of refrigerant piping shall conform to ANSI 831.5

6.2.0 Valves

- 6.2.1 Valves shall have full sizes port and suitable for horizontal and as well as vertical installation.
- 6.2.2 Valves for regulating duty shall be of globe type suitable for controlling throughout its lift.
- 6.2.3 All safety /relief valves shall be so constructed that the failure of any part does not obstruct the free discharge.
- 6.2.4 Valves shall be furnished with back seating arrangement for repacking while working under full working pressure.
- 6.2.5 Manual gear operators to be provided for valves of size 200 NB and above.
- 6.2.6 All valves shall be supplied with companion flanges, nut, bolts & washers, etc.
- 6.2.7 The refrigerant line valves shall have steel or brass body with TEFLON gland packing. The construction of disc shall be either globe or angle type. The valve seat shall have white metal lining or equivalent.
- 6.2.8 Gate valves shall be of Cast Iron body (confirming to IS: 210 Gr FG 220/equivalent) for sizes 65 NB and above conforming to IS: 14846. Gun Metal construction for sizes less than 65NB shall be as per IS: 778. Butterfly valves shall conform to latest revision of BS: 5155 or equivalent standard of required class/rating.

6.3.0 Air Filters

6.3.1 Pre Filter

- 1) Type : Flange / Cassette
- 2) Pre-filter shall contain washable non-woven synthetic fiber or High density Polyethylene (HDPE) media having 18G GSS or 16G Al alloy frame. The filter media shall be supported with HDPE mesh on air inlet side & Aluminum expanded metal on exit side or G.I. wire mesh on both sides.
- 3) Other requirements : (as applicable)
 - a) Suitable aluminum spacers be provided for uniform air flow;



- b) Casing shall be provided with neoprene sponge rubber sealing.
 - c) Capable of being cleaned by water flushing.
 - d) Density of filter medium shall increase in the direction of air flow in case of metallic filter.
 - e) Filter media shall be fire retardant and resistant to moisture, fungi, bacteria & frost.
- 4) Efficiency:
- Average arrestance of 65 - 80 % when tested in accordance with BS:65401ASHRAE-52-76 1 EN-779.
- 5) Minimum thickness : 50mm
 - 6) Face Velocity : Not more than 2.5 rn/sec.
 - 7) Pressure drop : Initial pressure drop - Not to exceed 5.0 mm WC at rated flow.
: Final pressure drop- Up to 7.5 mm WC.
 - 8) Location : a) At the suction of each AHUs
b) At the suction of each Fresh air fan

6.3.2 Fine Filters (Micro-vee type)

- 1) Type : Flange/Cassette
- 2) Fine filter shall contain washable non-woven synthetic fiber or High density Polyethylene (HDPE) media having 18G GSS or 16G Al alloy frame. The filter media shall be supported with HDPE mesh on air inlet side & Aluminum expanded metal on exit side or GI wire mesh on both sides.
- 3) Other requirements : a) A neoprene sponge rubber sealing shall be provided on either face of the filter frame.
b) Capable of being cleaned by air or water flushing.
c) Filter media shall be fire retardant and resistant to moisture, fungi, bacteria & frost.
- 4) Efficiency : Average arrestance > 90% when tested in accordance with BS:6540\ASHRAE-52-76 / EN-779.
- 4) Minimum thickness : 150 mm or 300 mm.
- 6) Face Velocity : Not more than 1.2 rn/sec for 150 mm and not more than 2.4 rn/sec. for 300 mm.
- 7) Pressure drop : Initial pressure drop - Not to exceed 10 mm we at rated flow
Final pressure drop-Up to 25 mm WC.



- 8) Location : i) At the discharge of each individual AHU.
ii) At the discharge of each Fresh air fan.

6.4.0 Low Pressure Air Distribution System

6.4.1 Material of air distribution system shall be through galvanized steel sheet (Conforming to Class 275 of IS :277) or Aluminum alloy (grade 19000 / SIC or 3100 I NS3 of IS:737). GI Sheets should be galvanized and galvanizing shall be of 275 gms/sq.m. (total coating on both sides) both for site fabricated and factory fabricated ducts.

6.4.2 Thickness of rectangular ducts shall be as follows:

Larger Dimension of duct (mm) GI sheet (mm)	Thickness of sheet (mm)	Thickness of Al sheet (mm)
up to 750 mm	0.63 (24 G)	0.80
751 to 1500	0.80 (22 G)	1.00
1501 to 2250	1.00 (20 G)	1.50
2251 & above	1.25 (18 G)	1.80

6.4.3 Thickness of round ducts shall be as follows:

Diameter of Round duct (mm)	Thickness of GI sheet(mm)	Thickness of Aluminium sheet (mm)
150 to 500	0.63	0.80
501 to 750	0.80	1.00
751 to 1000	0.80	1.00
1001 to 1250	1.00	1.50
1251 & above	1.25	1.80

6.4.4 Duct Fabrication and Supports:

- Duct fabrication shall be as per the latest relevant BIS/SMACNA standard.
- Ducts for A/C system may be site fabricated or factory fabricated.
- The ducts routed inside the buildings with larger side greater than 2250 mm shall be supported by 16mm MS rods and 50x50x3 mm MS double Angles while those below 2250 mm shall be supported by 10mm MS Rods and 40x40x3 MS angles. The duct supports shall be at a distance of not more than 2000 mm for A/C system. The MS rods for these ducts routed inside the building shall be hung from the existing floor beams/wall beams/roof beams/columns with provision of necessary auxiliary or special steel members or by



- hooks or can be provided by dash fasteners fixed to the ceiling slab. No supports shall be taken from horizontal/vertical bracings of the structures. All items of duct support including MS rods, MS angles and double angles, auxiliary or special steel members, hooks, dash fasteners coach screws and all other supporting material required shall be provided by the bidder. Where ever ducts are running outside the building and or at locations where it is not possible to support the ducts from ceiling/floor due to non-availability of the same, the base steel frame/truss work and other auxiliary steel members, hooks, rods, etc. for supporting the duct work shall also be provided by the Bidder.
- d) Where the sheet metal duct connects to the intake or discharge of fan units a flexible connection of fire retarding, at least 150 mm width shall be provided of closely woven, rubber impregnated double layer asbestos/canvas or neoprene coated fibre glass.
 - e) All curves, bends, off-sets and other transformations shall be made for easy and noiseless flow of air. The throat of every branch duct shall be sized to have the same velocity as in the main duct to which the branch duct is connected.
 - f) Wherever duct passes through a wall, the opening between masonry and duct work shall be neatly caulked or sealed to prevent movement of air from one space to the adjoining space.
 - g) Wherever pipe hangers or rods pass through the ducts, light and streamline easement around the same shall be provided to maintain smooth flow of air.
 - h) Access doors shall be provided in the duct work or casing on the both sides of the equipment to be serviced. All access doors shall be of adequate size and shall be lined with substantial felt edging to prevent air leakage. Access doors shall be of built up construction, structurally strong and each shall have at least two hinges. Access doors shall have two rust proof window sash of approved type. All doors shall be set so as to flush with insulation or plaster finish on the duct.
- 6.4.5 Splitters and dampers shall be provided for equipment/area isolation and for proportional volume control of system. The same shall be minimum 16 gauge GS sheet of quadrant type with suitable locking device, mounted outside of duct in accessible position.
- 6.4.6 **Factory fabricated ducts:**
- i) All ducting shall be fabricated of LFQ (Lock Forming Quality) grade prime G.I.
 - ii) Unless otherwise specified here, the construction, erection, testing and performance of the ducting system shall conform to the SMACNA-1995 standards ("HVAC Duct Construction Standards-Metal and Flexible-Second Edition-1995" SMACNA)
 - iii) All ductwork including straight sections, tapers, elbows, branches, show pieces, collars, terminal boxes and other transformation pieces must be factory fabricated by utilizing the machines and processes as specified in SMACNA or by equivalent technology. In equivalent method, the fabrication shall be done by utilizing the following machines and process to provide the requisite quality of ducts and speed of supply:
 - a) Coil lines to ensure location of longitudinal seams at corners/folded edges only to obtain the required duct rigidity and low leakage characteristics. No longitudinal seams permitted along any face side of the duct.



- b) All ducts, transformation pieces and fittings to be made on CNC profile cutters for required accuracy of dimensions, location and dimensions of notches at the folding lines.
 - c) All edges to be machine treated using lock formers, flangers and roll-bending for turning up edges.
 - d) Sealant dispensing equipment should be used for applying built-in sealant in Pittsburgh lock where sealing of longitudinal joints are specified. Sealing of longitudinal joint is compulsory for the ducts over 2" w.g. static pressure
- iv) All transverse connectors shall be 4-bolt slip-on flange system with built-in sealant, if any. To avoid any leakage additional sealant shall be used.
- v) Factory fabricated ducts shall have the thickness of the sheet as follows:

SI.No.	Size of Duct	Sheet thickness
i)	Upto 750 mm	0.63 mm
ii)	751 mm to 1500 mm	0.80 mm
iii)	1502 mm to 2250 mm	1.00 mm
iv)	2251 mm and above	1.25 mm

6.5.0 Diffusers, Grills & Dampers

- 6.5.1 Supply air diffusers/grills with factory fitted volume control dampers be provided for all air-conditioned areas.
- 6.5.2 Return air diffusers of air-conditioned areas shall be without volume control dampers.
- 6.5.3 The diffusers/grills shall be of extruded Aluminum of minimum 1.2 mm thick with powder coating. The colour of power coating shall be as per the interior decor.
- 6.5.4 Supply air grills shall be of double deflection type and return air grills shall be of single deflection type.
- 6.5.5 All volume control (VC) damper shall be operated by a key from the front of the grills/diffusers and shall be of GI sheet.
- 6.5.6 The thickness of VC dampers shall be of minimum 20 gauge and thickness of louvers shall be of minimum 22 gauge.
- 6.5.7 Suitable vanes shall be provided in the duct collar to have uniform and proper air distribution. Bank of Baffles wherever required shall also be provided.
- 6.5.8 Fire dampers shall be motor operated type and shall have fire rating of minimum 90 minutes.
- 6.5.9 All plenum chambers of connections to fans, dampers etc shall be constructed in 18 gauge GS sheet and supported on MS angle frames.



6.5.10 All ducting surfaces coming in contact with corrosive fumes or gases shall be painted with three coats of epoxy paint over a coat of suitable primer.

6.6.0 Thermal and Acoustic Insulation

6.6.1 A) Application with Glass Wool / Rockwool

- (i) All surfaces to be insulated both thermally and acoustically shall be thoroughly cleaned, dried and an adhesive (CPRX compound of Shalimar Tar Products I Loid bond 83 or Equivalent) be applied@ 1.5 Kg /Sqm on the surface.
- (ii) Insulation material (either expanded polystyrene foam or Glass Wool/ Glass fiber I Rockwool) shall be struck to the surface. All the joints shall be sealed with bitumen.
- (iii) Insulation mass to be covered with 500 gauge polythene sheet with 50 mm overlaps and sealing all joints on hot side or alternatively aluminum foil can be used which can come as lamination over insulation.
- (iv) Insulation Finish of types specified under shall be provided thereafter..

B) Application with Nitrile Rubber

- (i) All surfaces to be insulated shall be properly cleaned.
- (ii) A suitable adhesive such as SR 998 or equivalent shall be applied over the surfaces to be insulated and insulation material surfaces.
- (iii) Insulating material shall than be pasted onto the surfaces in a manner to avoid stretching and any air entrapment within.
- (iv) Two layers of Glass Cloth with a suitable adhesive as SR 998 or equivalent shall be then applied over the insulating material to avoid surface weathering.

C) Application with Polyurethane Foam & Polyisocyanurate Foam

- i) All surfaces to be insulated shall be cleaned.
- ii) A suitable adhesive such as CPRX or Loid Bond 83 or equivalent shall be applied over the surface to be insulated and insulation material surfaces.
- iii) Insulating material with aluminum foil lamination shall then be pasted onto the surface in a manner to avoid stretching and any air entrapment within.
- iv) Two layers of Glass Cloth with a suitable adhesive as Loid Bond 130 shall be then applied over the insulating material, to avoid surface weathering.
- v) Insulation Finish of types specified under shall be provided thereafter.



6.6.2 Type of Insulation & Finish

Sl. No.	Surface	Insulation Material	Insulation Form	Thick (mm)	Finish (mm)
1	Supply & return air duct of AC System	Resin bonded glass wool o4	Roll /Slab	50	F-3
		Closed Cell Elastomeric Nitrile Rubber	sheet	19	As per manufacturer std.
		or Polyisocyanurate Slab Foam	Slab	30	F-3
2.	Refrigerant (Suction and liquid lines)	Closed Cell tube Elastomeric Nitrile Rubber	Tube	19	As per manufacturer std.
		or Rigid Polyurethane Foam	Pipe Section	50	F-1 (a)
3.	AHU drain pipe	Closed Cell Elastomeric Nitrile Rubber	tube	19	As per manufacturer std.
		or Rigid Polyurethane Foam	Pipe Section	50	F-1 (a)
4.	AHU condensate pan (insulation if required)	Mineral wool or resin bonded glass wool	Slab	25	As per manufacturer std.
5	Acoustic insulation of duct	Resin bonded glass wool	Roll /Slab	25	As per manufacturer std. specifications
6	Exposed air duct	Resin bonded Glass wool/Rockwool	Roll/Slab	50	F-4
		or Polyisocyanurate Foam	Slab	50	F-4(a)



6.6.3 Specification for insulation shall be as follows: -

Insulation Material	Code	Thermal conductivity (w/rn/°C)	Density Kg/m3
Resin bonded glass wool	IS:8183	0.049 at 50°C	i) 24 (For Glass wool) ii) 48 (For Rockwool)
		0.043 at 50°C	iii) 48(For acoustic insulation)
Mineral wool pipe section. Min.Gr.2	IS:9842	0.043 at 50oc	144
Closed Cell Elastomeric Nitrile Rubber		0.036 at 20oc	40-60
Polyurethane Foam Polyisocyanurate Foam	IS12436	0.03 at 50 oc	34 .: +/- 2
		0.03 at 50 oc	34 .: +/- 2
Note : Insulation used for HVAC application shall be CFC/HCFC free			

6.6.4 The specification for various finishes shall be as follows

a)	Finish F-1 (with Resin Bonded Glass Wool/Resin Bonded Mineral Wool)
	Step-1 Wrapping of Poly-Bonded Hessain (PBH - to act as vapour seal) on outer surface of insulation with 50 mm overlap stitching and sealing of overlap with synthetic adhesive like CPRX or Equivalent compound.
	Step-2 The surface then shall be wrapped with 19 mm mesh 24 SWG GI wire netting, butting all the joints and laced down with 22 SWG lacing wire.
	Step-3 Sand cement (4:1) plaster shall be applied in two layers totalling to 12.5 mm thick, the second layer being brought to a smooth finish. A water proofing compound shall be added to the cement before its application.
aa)	Finish F-1 (a) (With Polyurethane Foam & Polyisocyanurate Foam) Wrapping of two layers of 7 mil 10 x 10 mesh glass cloth dipped in suitable adhesive such as SR 998 or Loid Bond 130 equivalent
b)	Finish F-2
	Step-1 Insulation shall be covered with 500g polythene with 50mm overlap and sealing of overlap with synthetic adhesive like CPRX/ Loid Bond 83 or Equivalent compound.
	Step-2 Same as Step-2 of Finish F-1 above.
	Step-3 Same as Step-3 of Finish F-1 above.
c)	Finish F-3
	Step-1 Same as Step-1 of Finish F-2 above



	Step-2	The polythene shall be covered with 26 gauge Aluminium sheet and locking of joints with self-locking screws at a pitch of minimum 100 mm.
d)	Finish F-4 Step-1 Step-2 Step-3 Step-4 Step-5	Same as Step-1 of Finish F-1 above. Same as Step-2 of Finish F-1 above. Same as Step-3 of Finish F-1 above. Application of 3 mm thick coat of suitable water proofing compound and wrapped with fibre glass RP tissue followed by final coat of 3 mm thick water proofing compound over the RP tissue After the above treatment, 22G Aluminium sheet cladding, properly stiched at all joints shall be provided over the external surface.
dd)	Finish F-4(a) (With FR Closed Cell Chemically Cross Linked Polyethylene)	Application of aluminium sheet 22G cladding to be provided over the XLPE insulating material. Cladding sheet is held in position with SDST screws @ 150 mm C/c over tongue-in-groove joints applied with a felt for sealing joint against water ingress. All sheet joints to be done in a manner to shed water

6.6.5 For all inspection covers and hatches on equipment, pump casing, valve bodies and flanges (100 mm and above), insulation shall be applied so as to facilitate removal without minimum damage to the insulation by encasing the insulation in 24 gauge GI box or 22 gauge Aluminium sheet metal boxes which are bolted together around the equipment. However continuity of the vapour seal between the static and removable portions of the insulation is to be maintained.

6.6.6 Acoustic Insulation

- a) All ducts up to a distance of 5 meters from AHU shall be acoustically lined from inside with 25 mm thick resin bonded glass wool of 48 Kg/Cu.M. density and 30 gauge perforated aluminium sheet having 5 mm dia perforation at 8 to 10 mm centre-to-centre distance. Insulation shall be fixed on wooden frame of 600 x 600 mm dimension.
- b) Fibre glass tissue sheet shall be applied over the outer surface of insulation before applying perforated aluminium sheet. Application of acoustic insulation shall be inline with the requirements specified above.

7.0.0 PLANT CONTROL

7.1.0 Brief scheme of controlling the operation is described below. Detailed description of the control system for safe and efficient operation of the plant shall be elaborated, got approved from employer. The descriptions in the sub-sections of the control & instrument sections shall also be referred to.

7.2.0 Control Scheme for Air-Conditioning System

Contractor shall provide microprocessor/PLC/GIU based control system for control and monitoring of air conditioning and ventilation system as per manufacturer's standard practice. Control and monitoring of air conditioning and ventilation system from FGD control system is also acceptable.

7.3.0 Air Handling Unit

- a) Humidity sensor and gysterstat located in the return air duct shall actuate the PAN humidifier to obtain the desired degree of humidification.



- b) Humidity and temp. sensor shall be provided and interlocked in steps with winter heater/re-heater/strip heaters for monsoon and winter re-heating or heating as the case may be.
- c) Heater banks shall be interlocked with the running of AHU, temperature of return air, humidity of return air and safety thermostat (airstat - located in front of the each heater in the supply air duct).
- d) AHU shall be started either locally or from the main control room of AC system by means of Remote/Manual selection facility.
- e) The closure of fire dampers, automatic tripping of AHU fans and fresh air fans shall be interlocked with Fire Detection System.

7.4.0 Cassette /Hi-wall Split Air Conditioners

Control and interlocks for these type of units shall be as per manufacturer's standard practice.

7.5.0 Miscellaneous Control Requirements

- a) The fans (both supply and exhaust fans) associated with mechanical ventilation system shall be operated locally.
- b) Relative humidity and temperature measurement of all control rooms and all major air-conditioned areas shall made be available in FGD control system.

8.0.0 PAINTING

- 8.1.0 All the equipments shall be protected against external corrosion by providing suitable painting.
- 8.2.0 The surfaces of stainless steel, Galvanized steel, Gunmetal, brass, bronze and non- metallic components shall not be applied with any painting. The Contractor shall clean the external surfaces and internal surfaces before Erection by wire brushing and air blowing. The steel surface to be applied with painting shall be thoroughly cleaned before applying painting by brushing, shot blasting, etc. as per the agreed procedure.
- 8.3.0 For all the steel surfaces (external) exposed to atmosphere (outdoor installation), one(1) coat of red oxide primer of thickness 30 to 35 microns followed up with three (3) coats of synthetic enamel paint, with 25 microns as thickness of each coat, shall be applied.
- 8.4.0 For all the steel surfaces inside the building (indoor installation), One (1) Coat of red oxide primer of thickness 30 to 35 microns followed up with two (2) coats synthetic enamel paint, with 25 microns as thickness of each coat shall be applied.
- 8.5.0 For centrifugal fans - Casing shall have hot dip/ spray galvanization (minimum 60 micron DFT).
- 8.6.0 However, for all parts coming in contact with acid fumes (in Battery rooms), a coat of epoxy resin based zinc phosphate primer of minimum thickness 30 to 35 microns followed up with undercoat of epoxy resin based paint pigmented with Titanium dioxide of minimum thickness of 25 microns shall be applied and a top coat consisting of one coat of epoxy paint of approved shade and colour with glossy finish of minimum thickness of 25 microns.



9.0.0 CODES & STANDARDS

The design, manufacture and performance of equipment shall comply with all currently applicable statues, regulations and safety codes in the locality where the equipments are to be installed. Nothing in this specification shall be considered to relieve the bidder of this responsibility.

Unless otherwise specified, equipment shall conform to the latest applicable Indian or IEC standard. Equipment complying with other authoritative standards such as British, USA, ASHRAE etc. will also be considered if it ensures performance equivalent or superior to Indian Standard.

10.0.0 PIPING THICKNESS

Pipes for sizes 200 NB & above shall confirm to IS: 3589 Grade 410. The thickness as mentioned below are the minimum specified nominal thickness as per IS: 3589. Tolerance as code shall be applicable.

Nominal pipe Size (mm)	Outside Diameter (mm)	Wall Thickness (mm)
200 NB	219.1	4.5
250 NB	273	5
300 NB	323.9	5.6
350 NB	355.6	5.6
400 NB	406.4	6.3
450 NB	457	6.3
500 NB	508	6.3
600 NB	610	6.3



**1x800 MW TANGEDCO NORTH CHENNAI
TPP– (FGD SYSTEM)
HVAC SYSTEM
TECHNICAL SPECIFICATION
(ELECTRICAL PORTION)**

SPECIFICATION No: PE-TS-485- (571-13000-A)-A001 (REV-0)

SECTION : I

SUB-SECTION : C-3

REV. 00

SECTION: I

SUB-SECTION: C3

TECHNICAL SPECIFICATION (ELECTRICAL PORTION)

**TAMILNADU GENERATION AND DISTRIBUTION
CORPORATION LIMITED**

**1X800MW TANGEDCO NORTH CHENNAI TPP STAGE-III
(FGD SYSTEM AND AUXILIARIES)**

**AIR CONDITIONING SYSTEM
TECHNICAL SPECIFICATION
(ELECTRICAL PORTION)**



**BHARAT HEAVY ELECTRICALS LIMITED
POWER SECTOR
PROJECT ENGINEERING MANAGEMENT,
NOIDA, U.P., INDIA**



TITLE:
**TECHNICAL SPECIFICATION
FOR
AIR CONDITIONING SYSTEM
1X800MW TANGEDCO NORTH CHENNAI TPP
STAGE-III (FGD SYSTEM & AUXILIARIES)**

SPECIFICATION NO.
VOLUME NO. : **II-B**
SECTION: **I**
REV NO.: **00** DATE: 06.07.22
SHEET: 1 OF 1

CONTENTS

SECTION	TITLE	NO OF SHEETS
I	SPECIFIC TECHNICAL REQUIREMENTS	2
I	ELECTRICAL SCOPE BETWEEN BHEL & VENDOR (ANNEXURE-I)	2
I	ELECTRICAL LOAD DATA FORMAT (ANNEXURE-II)	1
I	CABLE SCHEDULE FORMAT (ANNEXURE-III)	1
I	EXPLANATORY NOTES FOR CABLE ROUTING	2
I	TECHNICAL SPECIFICATION FOR MOTORS	9
I	MOTORS TEST/CHECK	2
II	MOTOR DATA SHEET-A	1
II	MOTOR DATASHEET-C	2
II	GENERAL TECHNICAL REQUIREMENT FOR LV MOTORS	4
II	SQP_LV MOTORS UPTO 55KW	2
II	SQP_LV MOTORS 55KW & ABOVE	9
II	CABLING ACCESSORIES	4
	SUB-VENDOR LIST	2

The requirements mentioned in Section-I shall prevail and govern in case of conflict between the same and the corresponding requirements mentioned in the descriptive portion in Section-II.



**ELECTRICAL EQUIPMENT SPECIFICATION
FOR
AIR CONDITIONING SYSTEM
1X800MW TANGEDCO NORTH CHENNAI TPP
STAGE-III (FGD SYSTEM & AUXILIARIES)**

SPECIFICATION NO.

VOLUME NO.: **II-B**

SECTION: **I**

REV NO.: **00** DATE: 06.07.22

SHEET : 1 OF 1

SPECIFIC TECHNICAL REQUIREMENTS: ELECTRICAL

1.0 EQUIPMENT & SERVICES TO BE PROVIDED BY BIDDER/ PURCHASER

- a) Services and equipment as per "Electrical Scope between BHEL and Vendor".
- b) Any item/work either supply of equipment or erection material which have not been specifically mentioned but are necessary to complete the work for trouble free and efficient operation of the plant shall be deemed to be included within the scope of this specification. The same shall be provided by the bidder without any extra charge.
- c) Supply of mandatory spares as specified in the specifications of mechanical equipments.
 - d) Electrical load requirement for **AIR CONDITIONING SYSTEM** (all AC & DC load at different voltage levels like 415V AC, 240 V AC, 220 V DC etc).
- e) All equipment shall be suitable for the power supply fault levels and other climatic conditions mentioned in the enclosed project information.
- f) Bidder to furnish list of makes for each equipment at contract stage, which shall be subject to customer/BHEL approval without any commercial and delivery implications to BHEL.
- g) Various drawings, data sheets as per required format, Quality plans, calculations, test reports, test certificates, operation and maintenance manuals etc shall be furnished as specified at contract stage. All documents shall be subject to customer/BHEL approval without any commercial implication to BHEL.
- h) Motor shall meet minimum requirement of motor specification.
- i) Vendor to clearly indicate equipment locations and local routing lengths in their cable listing furnished to BHEL.
- j) Cable BOQ worked out based on routing of cable listing provided by the vendor for "both end equipment in vendor's scope" shall be binding to the vendor with +10 % margin to take care of slight variation in routing length & wastages.

2.0 EQUIPMENT & SERVICES TO BE PROVIDED BY PURCHASER FOR ELECTRICAL & TERMINAL POINTS:

Refer "Electrical Scope between BHEL and Vendor".

3.0 DOCUMENTS TO BE SUBMITTED ALONG WITH BID

- 3.1 The electrical specification without any deviation from the technical/ quality assurance requirements stipulated shall be deemed to be complied by the bidder in case bidder furnishes the overall compliance of package technical specification in the form of compliance certificate/ No deviation certificate.
- 3.2 No technical submittal such as copies of data sheets, drawings, write-up, quality plans, type test certificates, technical literature, etc, is required during tender stage. Any such submission even if made, shall not be considered as part of offer.



**ELECTRICAL EQUIPMENT SPECIFICATION
FOR
AIR CONDITIONING SYSTEM
1X800MW TANGEDCO NORTH CHENNAI TPP
STAGE-III (FGD SYSTEM & AUXILIARIES)**

SPECIFICATION NO.

VOLUME NO.: **II-B**

SECTION: **I**

REV NO.: **00** DATE: 06.07.22

SHEET : 1 OF 1

4.0 LIST OF ENCLOSURES

- 4.1 Electrical Scope Between BHEL & Vendor (Annexure-I).
- 4.2 Electrical Load Data Format (Annexure-II).
- 4.3 Cable Schedule Format (Annexure-III).
- 4.4 Technical Requirements-Motors.
- 4.5 Data Sheet-A & C
- 4.6 Standard Quality Plan.
- 4.7 Technical Requirements –Earthing & Lightning Protection System
- 4.8 Technical Requirements- Cabling Accessories
- 4.9 Motor Sub Vendor List

ELECTRICAL SCOPE BETWEEN BHEL AND VENDOR

PACKAGES : HVAC SYSTEM

SCOPE OF VENDOR: SUPPLY, ERECTION & COMMISSIONING OF VENDOR'S EQUIPMENT

PROJECT: 1X800MW TANGEDCO NORTH CHENNAI TPP STAGE-III (FGD SYSTEM & AUXILIARIES)

S.NO	DETAILS	SCOPE SUPPLY	SCOPE E&C	REMARKS
1	415V MCC	BHEL	BHEL	240 V AC (supply feeder)/415 V AC (3 PHASE 4 WIRE) supply shall be provided by BHEL based on load data provided by vendor at contract stage for all equipment supplied by vendor as part of contract. Any other voltage level (AC/DC) required will be derived by the vendor.
2	Local Push Button Station (for motors)	BHEL	BHEL	Located near the motor.
3	Power cables, control cables and screened control cables for a) both end equipment in BHEL's scope b) both end equipment in vendor's scope c) one end equipment in vendor's scope	BHEL BHEL BHEL	BHEL Vendor BHEL	1. For 3.b) & c): Sizes of cables required shall be informed by vendor at contract stage (based on inputs provided by BHEL) in the form of cable listing. Finalisation of cable sizes shall be done by BHEL. Vendor shall provide lugs & glands accordingly. 2. Termination at BHEL equipment terminals by BHEL. 3. Termination at Vendor equipment terminals by Vendor.
4	Junction box for control & instrumentation cable	Vendor	Vendor	Number of Junction Boxes shall be sufficient and positioned in the field to minimize local cabling (max 10-12 mtrs) and trunk cable.
5	Any special type of cable like compensating, co-axial, prefab, MICC, optical fibre etc.	Vendor	Vendor	Refer C&I portion of specification for scope of fibre Optical cables if used between PLC/ microprocessor & DCS.
6	Cable trays, accessories & cable trays supporting system 100/ 50 mm cable trays/ Conduits/ Galvanised steel cable troughs for local cabling	BHEL Vendor	BHEL Vendor	Local cabling from nearby main route cable tray (BHEL scope) to equipment terminal (vendor's scope) shall be through 100/ 50 mm. cable trays/ conduits/ Galvanised steel cable troughs, as per approved layout drawing during contract stage.
7	Cable glands ,lugs and bimetallic strip for equipment supplied by Vendor	Vendor	Vendor	1. Double compression Ni-Cr plated brass cable glands 2. Solder less crimping type heavy duty tinned copper lugs for power and control cables.
8	Conduit and conduit accessories for cabling between equipment supplied by vendor	Vendor	Vendor	Conduits shall be medium duty, hot dip galvanised cold rolled mild steel rigid conduit as per IS: 9537.
9	Lighting	BHEL	BHEL	
10	Equipment grounding (including electronic earthing) & lightning protection	BHEL	BHEL	Refer note no. 4 for electronic earthing

ELECTRICAL SCOPE BETWEEN BHEL AND VENDOR

PACKAGES : HVAC SYSTEM

SCOPE OF VENDOR: SUPPLY, ERECTION & COMMISSIONING OF VENDOR'S EQUIPMENT

PROJECT: 1X800MW TANGEDCO NORTH CHENNAI TPP STAGE-III (FGD SYSTEM & AUXILIARIES)

S.NO	DETAILS	SCOPE SUPPLY	SCOPE E&C	REMARKS
11	Below grade grounding	BHEL	BHEL	
12	LT Motors with base plate and foundation hardware	Vendor	Vendor	Makes shall be subject to customer/ BHEL approval at contract stage.
13	Mandatory spares	Vendor	-	Vendor to quote as per specification.
14	Recommended O & M spares	Vendor	-	As specified elsewhere in specification
15	Any other equipment/ material/ service required for completeness of system based on system offered by the vendor (to ensure trouble free and efficient operation of the system).	Vendor	Vendor	
16	a) Input cable schedules (Control & Screened Control Cables) b) Cable interconnection details for above c) Cable block diagram	Vendor Vendor Vendor	- - -	Cable listing for Control and Instrumentation Cable and electronic earthing cable in enclosed excel format shall be submitted by vendor during detailed engineering stage.
17	Electrical Equipment & cable tray layout drawings	Vendor	-	For ensuring cabling requirements are met, vendor shall furnish Electrical equipment layout & cable tray layout drawings (both in print form as well as in AUTOCAD) of the complete plant (including electrical area) indicating location and identification of all equipment requiring cabling, and shall incorporate cable trays routing details marked on the drawing as per PEM interface comments. Cabling arrangement of the same (wherever overhead cable trays, trenches, cable ducts, conduits etc.) shall be decided during contract stage. Electrical equipment layout & cable tray layout drawing shall be subjected to BHEL/ customer approval without any commercial implications to BHEL.
18	Electrical Equipment GA drawing	Vendor	-	For necessary interface review.

NOTES:

1. Make of all electrical equipment/ items supplied shall be reputed make & shall be subject to approval of BHEL/customer after award of contract.
2. All QPs shall be subject to approval of BHEL/customer after award of contract without any commercial implication.
3. In case the requirement of Junction Box arises on account of Power Cable size mis-match due to vendor engineering at later stage, vendor shall supply the Junction Box for suitable termination.
4. Vendor shall indicate location of Electronic Earth pit in their Civil assignment drawing.

LOAD TITLE	RATING (KW / A)		UNIT (U)/STN (S)	Nos.		VOLTAGE CODE*	FEEDER CODE**	EMER. LOAD (Y)	CONT.(C)/ INTT.(I)	STARTING TIME >5 SEC (Y)	LOCATION	BOARD NO.	CABLE		BLOCK CABLE DRG. No.	CONT ROL CODE	REMA RKS	LOAD No.	VERIFICATI ON FROM MOTOR DATASHEE T (Y/N)	KKS NO
	NAME PLATE	MAX. CONT. DEMAND (MCR)		RUNNING	STANDBY								SIZE CODE	NOs						
1	2	3	4	5	6	7	8	9	10	11	12	13	14	15	16	17	18	19	20	21

ANNEXURE-II

NOTES: 1. COLUMN 1 TO 12 & 18 SHALL BE FILLED BY THE REQUISITIONER (ORIGINATING AGENCY); REMAINING COLUMNS ARE TO BE FILLED UP BY PEM (ELECTRICAL)/ CUSTOMER
2. ABBREVIATIONS : * VOLTAGE CODE (7):- (ac) A=11 KV, B=6.6 KV, C=3.3 KV, D=415 V, E=240 V (1 PH), F=110 V (cc): G=220 V, H=110 V, J=48 V, K=+24V, L=-24 V
:** FEEDER CODE (8):- U=UNIDIRECTIONAL STARTER, B=BI-DIRECTIONAL STARTER, S=SUPPLY FEEDER, D=SUPPLY FEEDER (CONTACTER CONTROLLED)

LOAD DATA (ELECTRICAL)	JOB NO.	485	ORIGINATING AGENCY		PEM (ELECTRICAL)	
	PROJECT TITLE	1X800MW TANGEDCO NORTH CHENNAI TPP STAGE-III (FGD SYSTEM & AUXALIRIES)	NAME		DATA FILLED UP ON	
	SYSTEM	Air Conditioning System	SIGN.		DATA ENTERED ON	
	DEPTT. / SECTION	MAUX	SHEET 1 OF 1	REV. 00	DE'S SIGN. & DATE	

Explanatory notes for filling up cable list for routing through WinPath, the cable routing program (developed by Corporate R&D) being used in PEM.

1. For the purpose of clarity, it may please be noted that the information given in regard to the cables to be routed through WinPath as per the system elaborated below is called "Cable List", while the term "Cable Schedule" applies to the cable list with routing information added after routing has been carried out.
2. The cable list shall be entered as an MS Excel file in the format as per enclosed template EXT_CAB_SCH_FORMAT.XLS. No blank lines, special characters, header, footer, lines, etc. shall be introduced in the file. No changes shall be made in the title line (first line) of the template.
3. The field properties shall be as under:
 - a. UNITCABLENO: A/N, up to sixteen (16) characters; each cable shall have its own unique, unduplicated cable number. In case this rule is violated, the cable cannot be taken up for routing.
 - b. FROM: A/N, up to sixty (60) characters; the "From" end equipment/ device description and location to be specified here. Information in excess of 60 characters will be truncated after 60 characters.
 - c. TO: A/N, up to sixty (60) characters; the "To" end equipment/ device description and location to be specified here. Information in excess of 60 characters will be truncated after 60 characters.
 - d. PURPOSE: A/N, up to sixty (60) characters; the purpose (i.e. power cable/ indication/ measurement, etc.) to be specified here. Information in excess of 60 characters will be truncated after 60 characters.
 - e. REMARKS: A/N, up to forty (40) characters; Any information pertinent to routing to be specified here (e.g., cable number of the cable redundant to the cable number being entered). Information in excess of 40 characters will be truncated after 40 characters.
 - f. CABLESIZE: A/N, 7 characters exactly as per the codes indicated below shall be specified here. The program cannot route cables described in any other way/ format.
 - g. PATHCABLENO: Field reserved for utilization by the program. User shall not enter any information here.
4. One list shall be prepared for each system/ equipment (i.e., separate and unique cable lists shall be prepared for each system).
5. The cables shall be described as per the scheme listed below:

A	NN	A	NNN
Cable	No. of cores	Cable code	Cable size
Voltage	(e.g. 01,03,3H, 07)	(See C below)	(e.g. 035,185,2.5, 0.5)
Code (see B below)			

(A) SYSTEM VOLTAGE CODES:

(ac) A = 11KV, B = 6.6KV, C = 3.3KV, D = 415V, E = 240V, F = 110V
 (dc) G = 220V, H = 110V, J = 48V, K = +24V, L = -24V

(B) CABLE VOLTAGE CODES:

A = 11KV (Power cables)

Explanatory notes for filling up cable list for routing through WinPath, the cable routing program (developed by Corporate R&D) being used in PEM.

- B = 6.6KV (Power cables)
- C = 3.3KV (Power cables)
- D = 1.1KV (LV & DC system power & control cables)
- E = 0.6KV (0.5 sq. mm. Control cables)

(C) CABLE CODES

PVC Copper

- A = Armoured FRLS
- B = Armoured Non-FRLS
- C = unarmoured FRLS
- D = Unarmoured Non-FRLS

PVC Aluminium

- E = Armoured FRLS
- F = Armoured Non-FRLS
- G = unarmoured FRLS
- H = Unarmoured Non-FRLS

XLPE Copper

- J = Armoured FRLS
- K = Armoured Non-FRLS
- L = unarmoured FRLS
- M = Unarmoured Non-FRLS

XLPE Aluminium

- N = Armoured FRLS
- P = Armoured Non-FRLS
- Q = unarmoured FRLS
- R = Unarmoured Non-FRLS

- S = FIRE SURVIVAL CABLES
- T = TOUGH RUBBER SHEATH
- U = OVERALL SCREENED
- V = PAIRED OVERALL SCREENED
- W = PAIRED INDIVIDUAL SCREENED
- Y = COMPENSATING CABLES
- I = PRE-FABRICATED CABLES
- Z = JELLY FILLED CABLES



SECTION-I

SECTION : 3.1- MOTORS

1.0.0 INTENT OF SPECIFICATION

This section covers the technical requirements of HT and LT Motors.

2.0.0 CODES AND STANDARDS

The equipment to be furnished under this specification shall be in accordance with the applicable section of the latest edition (including amendments) of the following Indian Standards (IS), IEC publications and other codes, especially the Indian Statutory Regulation, except where modified and /or supplemented by this specification.

- a) IS: 325 Three phase induction motors
- b) IS: 12615 Energy efficient induction motors
- c) IS: 900 Code of practice for installation and maintenance of induction motors
- d) IS: 996 Single-phase AC induction motor for general purpose
- e) IS: 1231 Dimensions of three-phase foot-mounted induction motors
- f) IS: 2223 Dimensions of flange mounted AC induction motors
- g) IS: 4029 Guide for testing three-phase induction motors
- h) IS: 8789 Values of performance characteristics for three-phase induction motors
- i) IS: 13555 Guide for selection and application of 3-phase AC induction motors for different types of driven equipment
- j) IS: 5571 Guide for selection of electrical equipment for hazardous areas
- k) IS: 12065 Permissible limits of noise level for rotating electrical machines
- l) IS: 12075 Mechanical vibration of rotating electrical machines
- m) IS: 9334 Electrical motor operated actuators
- n) IS 60034-5 Degree of protection provided by Integral design of rotating electrical machines
- o) IS 60034-8 Terminal marking and direction of rotation
- p) IS 60079-1 Equipment protection by flame proof enclosure
- q) IS 60034-1 Rotating electrical machines.
- r) IS 60079 Explosive atmospheres
- s) IS/IEC 60529 Degrees of protection provided by enclosures (IP code)
- t) IEC 60034 Rotating electrical machines.

3.0.0 TECHNICAL REQUIREMENTS

3.1.0 Design ambient temperature

Motors shall be suitable for an ambient temperature of 50 degree C and relative humidity of 95% and shall deliver the rated output without exceeding its guaranteed temperature limits. The equipment shall operate in highly polluted environment.

3.2.0 Supply voltage

Motors rated up to and including 415V are termed as LT motors and the motors rated higher than 415V are termed as HT motors.

Motors shall be capable of delivering the rated output under following voltage and frequency variations without exceeding its guaranteed temperature limits.



- Frequency variation : (+) 3% and (-) 5%
- Voltage variation for LT motors : (±) 10%
- Voltage variation for HT motors : (±) 10%
- Combined variation of voltage and frequency : 10% (absolute sum)

All the motors shall be so designed that maximum inrush currents, locked rotor torque and pullout torque developed at extreme voltage and frequency variations do not endanger the motor and the driven equipment.

3.3.0 System Parameters

Sl. No.	Description	HT System	LT System
1.	Voltage level	11 KV Above 2000 KW 6.6KV above 200KW & upto 2000KW	240 V : up to 0.2 KW 415 V : >0.2 KW and up to 200KW .
2.	System earthing	Earthed through resistance. Earth fault current : 300 Amps	415V: Solidly grounded.
3.	System fault level	50 KA for 3 sec for 11KV 40KA for 1sec for 6.6KV	50 KA for 1 second
4.	Fault withstand rating of motor terminal box (Breaker operated)	50 KA for 0.25 sec for 11KV 40KA for 0.25 sec for 6.6KV	50 KA for 0.25 second

3.4.0 Type

- AC Motors shall be squirrel cage induction type unless otherwise it is specified. All the motor shall be bi-directional.

3.5.0 Duty

- All AC motors shall be squirrel cage three phase/single phase induction motors. All the motor shall be designed for bi-directional rotation.
- Motors shall be suitable for installation in hot, humid and tropical atmosphere and polluted at places with coal ash and fly ash or any dusty chemical handling area.
- All LV motors above 10KW shall be with S1 duty.

3.6.0 Design margin

- Motor rating shall be selected higher than the maximum load demand of the driven equipment, as per the criteria stated in mechanical section of this specification, under entire operating range, including voltage and frequency variation.
- The motor name plate rating shall have 15% margin over duty point input (or) 10% margin over the maximum demand of driven equipment whichever is higher considering highest system frequency.
- The motor characteristics shall match the requirements of the driven equipment so that adequate starting, accelerating; pull up, breakdown and full load torques are available for the intended service.
- Service shall be considered as 1.0 only.



3.7.0 Method of Starting

- All the motors shall be suitable for direct on-line starting on full load.
- HT Motors will be controlled through vacuum circuit breaker.
- LT motors rated less than 90KW will be controlled through MPCB/MCCB and contactor. LT motors rated 90 KW and above will be controlled through air circuit breaker (ACB).

3.8.0 Efficiency

All the continuous duty motors shall be energy efficient type. For LT motors, it shall be IE3 class as per IS 12615. For HT motors, efficiency shall be more than 95%.

3.9.0 Temperature rise

- Winding Insulation shall be Class F.
- Temperature rise of motors shall not exceed 70°C over air temperature of 50°C by resistance method, while delivering its maximum rated output.

3.10.0 Starting voltage

- a) Motors shall be capable of starting and accelerating the load at following starting voltage, with direct on line starting, without exceeding specified winding temperatures.
 - HT Motors : 85% of rated voltage
 - LT motors : 80% of rated voltage
- b) During fast changeover of power supply source, vector difference between the motor residual voltage and the incoming supply voltage will be about 150% of the rated voltage and the motors shall withstand voltage stress and torque stress developed during that time, which may last for a period of one (1) second.
- c) The motor shall be capable of operating at full load at a supply voltage of 80% of the rated voltage for 5 minutes.
- d) The motor shall be capable of withstanding the stresses imposed if started at 110% rated voltage.
- e) Motor shall not stall if the supply voltage drops to 70% of the rated voltage two (2) second duration

3.11.0 No. of Starts

Continuous duty motors shall be suitable for the following starting requirements under the specified conditions of load, torque and inertia.

- No. of consecutive hot starts shall be 2 (with initial temperature of the motor at full load operating level).
- No. of consecutive cold starts shall be 3 (with initial temperature of the motor at ambient temperature).
- For conveyor motors, no. of consecutive hot starts shall be 3 (with initial temperature of the motor at full load operating level).



3.12.0 Starting current

- Motor shall be designed for direct online starting at full voltage. Starting current shall not exceed 6 times full load current for all auxiliaries. No further tolerances are applicable on starting current specified above for HT motors.
- For LT motors, the applicable starting current shall be limited to 7.2 times of full load current including all tolerance.

3.13.0 Locked rotor withstand time

- The locked rotor withstand time for HT motors under hot conditions at 110% rated voltage shall be more than the starting time at minimum permissible voltage specified above by atleast three seconds or 15% of the accelerating time whichever is greater.
- For the LT motors having starting time upto 20 seconds at minimum permissible voltage, the locked rotor withstand time under hot condition at highest voltage limit shall be at least 2.5 seconds more than the starting time.
- For the motors having starting time more than 20 seconds and up to 45 seconds at minimum permissible voltage, the locked rotor withstand time under hot condition at highest voltage limit shall be at least 5 seconds more than the starting time.
- For motors having starting time more than 45 seconds at minimum permissible voltage, the locked rotor withstand time under hot condition at highest voltage limit shall be more than starting time by at least 10% of the starting time.
- The motors shall be designed to withstand 120% of rated speed for 2 minutes without any mechanical damage
- All motors shall be so designed that maximum in rush currents and locked rotor and pull out torque developed by them at extreme voltage and frequency variation do not endanger the motor & driven equipment.

3.14.0 Torque Requirements

- Accelerating torque at any speed with the lowest permissible starting voltage shall be at least 10% motor full load torque.
- Pull out torque at rated voltage shall not be less than 205% of full load torque.
- Motors subjected to reverse rotation shall be designed to withstand the stresses encountered when starting with non-energized shaft rotating at 125% of rated speed in reverse direction.
- The motor shall be designed to withstand momentary overload of 60% of full load torque for 15 second without any damage.

3.15.0 Enclosure

- a) All motor enclosures shall conform to the degree of protection IP 55 unless otherwise specified. Motor for outdoor or semi outdoor service shall be of weather proof construction.
- b) For hazardous location, the enclosure of motors shall have flame proof construction conforming to applicable standard.



3.16.0 Cooling

- LT motors shall be totally enclosed fan cooled (TEFC), type IC411. The cooling shall be effected by self-driven bi-directional centrifugal fan protected by fan cover.
- HT motors can be totally enclosed fan cooled (TEFC) or totally enclosed tube ventilated (TETV) or closed air circuit air cooled (CACA) type.
- Motors rated >3000KW can be closed air circuit water cooled (CACW).
- Motors with CACA/CACW heat exchangers shall have dial type thermometer with adjustable alarm contacts to indicate the following:
 - Hot and cold air temperatures of the closed air circuit for CACA motors.
 - Hot and cold, air and water temperatures for CACW motors.
- The Alarm switch contact rating shall be minimum 0.5 A at 220 V DC and 5A at 240 V AC.

3.17.0 Winding

- Winding shall be class F insulation with temperature limited to class B. Insulation shall be Non-hygroscopic, oil resistant, and flame resistant. Winding, fittings and hardware shall be corrosion resistant. Winding shall be tropicalized and suitably varnished, baked and treated for operating satisfactorily in humid and corrosive atmosphere.
- For the VFD operated drives, insulation shall be designed to take care of stresses due to high Dv/dt. Motors shall be wound with dual coated winding wires and impregnated with VPI process. Further for such application, insulated bearings shall be provided to avoid circulating current caused by shaft induced voltages.
- Space heaters rated for 240V AC, 50 Hz supply shall be provided for motors rated 30KW and above to maintain windings in dry condition when motor is standstill.
- For HT motors, insulation shall be Vacuum Impregnated (VPI).
- HT motors shall withstand 1.2/50 microsec impulse Voltage wave of 4U+5 KV (U=Line voltage in KV). The coil inter-turn insulation shall be suitable for 0.3/3msec surge of 32KVp and 12KVp for 11KV & 6.6KV system respectively, followed by 1 min power frequency high voltage test of appropriate voltage on inter turn insulation.

Temperature Detectors

- All 11KV motors shall be provided with six (6) nos. duplex, or twelve (12) nos. simplex type winding temperature detectors, i.e. two (2) nos. duplex or four (4) nos. Simplex per phase.
- 11KV motor bearing shall be provided with duplex type temperature detectors.
- The temperature detector mentioned above shall be resistance type, 3 wire, platinum wound, 100 Ohms at 0°C.
- Leads of all simplex type motor winding RTDS and motor bearing RTDS shall be wired up to respective switchgear metering & protection compartment. From which one set of RTDS will be connected to numerical protection relay and another set shall be kept free for DCS/PLC connectivity.
- Five number of Temperature detectors / thermistors shall be provided for L.T. motors above 90 KW (3 numbers winding temperatures & 2 numbers bearing temperatures)



3.18.0 Bearings

- Motor shall be provided with antifriction bearings, unless sleeve bearings are required by the motor application. Bearings shall be provided with seals to prevent leakage of lubricant or entrance of foreign matters like dirt, water etc. into the bearing area.
- Sleeve bearings shall be split type, ring oiled with permanently aligned, close running shaft sleeves. Grease lubricated bearings shall be pre-lubricated and shall have provisions for in-service positive lubrication with grease nipple and relief holes.
- Vertical shaft motors shall be provided with thrust and guide bearings. Thrust bearing of tilting pad type is preferred. However, if anti-friction bearings can take vertical thrust, thrust and guide bearings are not required.
- Lubricant shall not deteriorate under all service conditions. The lubricants shall be limited to normally available types. For motors rated 30KW and above re-lubrication facility shall be provided.
- For motor with forced lubrication, a shaft driven oil pump shall be provided along with an electrical auxiliary pump. Alternatively, two motor driven pumps may be provided, one working and one standby. All necessary auxiliaries and accessories shall be provided to complete the system. A pressure gauge and pressure switch for low oil pressure warning and to start the standby oil pump automatically shall also be provided. A motor driven jacking oil pump may be provided, for heavy shaft loads.
- Flow switches shall be provided for monitoring oil flow of forced lubrication bearings, if used. Alarm switch contact rating shall be minimum 0.5 A at 220 V DC and 10A at 230 V AC.
- For bearing temperature measurement, duplex RTDs shall be provided for each bearing and shall be wired upto the terminal box.
- Each bearing shall be provided with dial type thermometer.
- For all VFD operated motors and motors rated above 1000KW shall have insulated bearings to prevent flow of shaft currents.

3.19.0 Terminal Boxes

- For single core cables, gland plate shall be non-magnetic material. Terminal box shall be capable of being turned 360° in steps of 90°, unless otherwise approved. The terminal boxes shall be split type with removable cover with access to connections.
- Terminals for motors shall be stud type, thoroughly insulated from the frame. The terminals shall be clearly identified by phase markings, with corresponding direction of rotation marked on the non-driving end of the motor.
- The terminal box shall be capable of withstanding maximum system fault current for 0.25 sec for all breaker operated motors and shall be provided with explosion vent.
- For contactor operated LT motors, the terminal box shall be capable of withstanding the fault current for 0.2 sec minimum and operating time of MPCB/MCCB.
- Removable gland plates of thickness not less than 2.5 mm sheet steel or 3 mm aluminium (for single core cables) shall be provided for cable boxes.
- Cable spreader box shall be provided for larger cable sizes.



- Cable boxes of HT motors shall be phase segregated type. The terminals of three phases shall be segregated by barriers of metal or fibre glass. For HT motors, cable box design shall be suitable for accommodating cable termination kits.
- Separate terminal box for space heaters shall be provided.
- A separate terminal box of IP 55 degree of protection shall be provided for temperature detectors.
- Motor 1000 KW and above shall be provided with three differential current transformers mounted over the neutral leads within the enclosure. Loose 3 numbers CT for mounting on switchgear side shall be in bidder's scope. The arrangement shall be such as to permit easy access for C.T. testing and replacement. Current transformer characteristics shall match Owner's requirements to be intimated later to the successful bidder. The CT details shall be finalized during detail engineering. Neutral terminal box shall have IP 55 degree of protection.
- The secondary leads of CT shall be wired to separate auxiliary terminal box of IP 55 degree of protection
- All the accessory terminal boxes shall be located on the same side of the main (power) terminal box.
- For LT motors, terminal box shall be located on top, unless otherwise specified.

3.20.0 Earthing Terminals

The frame of each motor shall be provided with two separate and distinct grounding pads complete with tapped hole, GI bolts and washer. The terminal box shall have a separate grounding terminal.

The grounding connection shall be suitable for accommodation of ground conductors as follows :

Above 100 to 200 KW	: 75x10 mm GS flat
Above 55 KW to 100 KW	: 50x6 mm GS flat
Above 22 KW to 55 KW	: 50x6 mm GS flat
Above 5.5 KW to 22 KW	: 25x6 mm GS flat
Fractional HP LV Motors	: 8 SWG GS Wire

3.21.0 Noise and Vibration

- Motors shall be selected with low noise levels in accordance with IS 12065. Noise level for all motors shall be limited to 85db (A).
- The peak amplitude of the vibration shall also be within the specified limits of IS: 12075.
- All HT motors shall be provided with vibration pads for mounting vibration detectors. Motors shall withstand vibration produced by driven equipment.

3.22.0 Name Plates

Motor shall have stainless steel nameplate(s) showing diagram of connections, all particulars as per IS: 325 / IS: 12615 and shall also have 'BEE' marking.

In addition to the minimum information required by IEC/IS, the following information shall be shown on motor rating plate:

- Temperature rise in °C under rated condition and method of measurement.



- Degree of protection.
- Bearing identification no. and recommended lubricant.
- Location of insulated bearings.

3.23.0 Drain plug

Motor shall have drain plugs so located that they will drain the water, resulting from the condensation or other causes from all pockets of the motor casing.

3.24.0 Lifting provision

Motor weighing 25 Kg. or more shall be provided with eyebolt or other adequate provision of lifting.

3.25.0 Dowel pins

The motor shall be designed to permit easy access for drilling holes through motor feet or mounting flange for installation of dowel pins after assembling the motor and driven equipment

4.0.0 INSTALLATION

Installation shall be carried out as per IS: 900.

5.0.0 PAINTING

Painting shall be carried out by an approved process. Pretreatment shall conform to applicable standard. The equipment shall be subject to a coat of red oxide primer paint. All inside and outside surface shall be painted with epoxy based paint. The final thickness of paint film on steel shall not be less than 100 microns. Paint Shade for the Motor shall be RAL 7032 (Siemens Grey). Sufficient quantity of touch-up paint shall be furnished for application at site.

6.0.0 TESTING AND INSPECTION

- 6.1.0 Tests shall be performed in presence of Owner's representatives. Successful Bidder shall give atleast fifteen (15) days advance notice for witnessing the tests. Copies of certified reports of all tests carried out at the works shall be furnished. The equipment shall be dispatched from works, only after receipt of Owner's written approval of the test reports.
- 6.2.0 Routine and Type Tests are to be conducted for all HT motors and for LT motors above 60 KW rating in presence of customer's representative as per IS:325, IS:4722, IS:9283 and required copies of test certificates are to be furnished for approval.
- 6.3.0 Test certificates for Routine tests conducted as per IS:325, IS:4722, IS:9283 for motors of rating 60 KW and below shall be submitted for TANGEDCO review, approval and dispatch clearance.
- 6.4.0 The following minimum tests/ checks shall be conducted at site. Any other tests/ checks as per the manufacturer's recommendation shall also be carried out
- i) Measurement of vibration.
 - ii) Measurement of insulation resistance and polarization index
 - iii) Measurement of full load current.
 - iv) Test running of the motors, checking the temperature rise and identifying the hot spot etc.



7.0.0 OTHERS

- 7.1.0 The responsibility of co-ordination with electrical agencies and obtaining all necessary clearances shall be the contractor.
- 7.2.0 Canopy shall be provided for outdoor motors.
- 7.3.0 Contractor shall provide fully compatible electrical system, equipment, accessories and services.

8.0.0 SPECIFIC REQUIREMENTS

- 8.1.0 The following shall be considered for control & protection of motors.
- a) Motors below 18.5 KW: MPCB incomers
 - b) Above 18.5 KW but below 90 KW: contactor controlled with MCCB
 - c) 90 KW and above but 160 KW & below: ACB controlled with numerical relays
 - d) HT Motors shall have vacuum breakers
 - e) HV motors 1000KW above shall have differential protection
 - f) For motors 1000KW & above, neutral CT of CI. PS shall be provided as each box on separate terminal box
 - g) Key phasor arrangement shall be provided for all motors
 - h) All motors shall be provided with an emergency stop PB near motor as per Indian Statutory regularity.
 - i) Spacious platform shall be provided around motor area with min. of 300mm below the level of motor base plate.
 - j) Capillary type temp. Gauge cum shall be provided for DE/NDE of HV motors
 - k) After erection of electrical equipment at site, corrosion proof paint touch up to be done before test & commissioning of equipment.



SECTION-I

2.3.0 MOTORS

Item/ Components/ Sub-system	Tests/ Checks																	
	Visual	Dimensional	Make, Type, Rating, TC, General physical	Mechanical, Chemical properties	NDT, DP or MPI, UT	Metallography	Electrical characteristics	Welding/ Brazing (WPS/ PQR)	Heat treatment	Magnetic characteristics	Hydraulic, Leak, Pressure test	Thermal characteristics	Run out	Dynamic balancing	All tests as per IS:325/ IS:4722/ IS:9283	Vibration	Over speed	Tan delta, shaft voltage and polarisation
Plates for stator frame, end shield, spider etc.	Y	Y	Y	Y				Y										
Shaft	Y	Y	Y	Y	Y	Y		Y										
Magnetic material	Y	Y	Y	Y	Y		Y		Y		Y							
Rotor copper/ Aluminium	Y	Y	Y	Y		Y	Y	Y										
Stator copper	Y	Y	Y	Y			Y	Y			Y							
SC ring	Y	Y	Y	Y	Y	Y	Y	Y	Y									
Insulating material	Y		Y	Y			Y				Y							
Tubes for cooler	Y	Y	Y	Y	Y			Y		Y								
Sleeve bearing	Y	Y	Y	Y	Y			Y		Y								
Stator, Rotor coils	Y	Y	Y				Y	Y										
Castings, stator frame, terminal box and bearing housing etc.	Y	Y	Y	Y	Y			Y										
Fabrication and machining of stator, rotor, terminal box	Y	Y			Y			Y										
Wound stator	Y	Y					Y	Y										
Rotor complete	Y	Y					Y					Y	Y					



Item/ Components/ Sub-system	Tests/ Checks																	
	Visual	Dimensional	Make, Type, Rating, TC, General physical	Mechanical, Chemical properties	NDT, DP or MPI, UT	Metallography	Electrical characteristics	Welding/ Brazing (WPS/ PQR)	Heat treatment	Magnetic characteristics	Hydraulic, Leak, Pressure test	Thermal characteristics	Run out	Dynamic balancing	All tests as per IS:325/ IS:4722/ IS:9283	Vibration	Over speed	Tan delta, shaft voltage and polarisation
Stator, Rotor, Terminal Box assembly	Y	Y					Y											
Accessories, RTD, BTD, CT, Brushes, Diodes, space heater, antifriction bearing, cable glands, lugs, gaskets etc.	Y	Y	Y															
Complete motor (IS: 325/ IS:4722/ IS:9283)	Y	Y	Y											Y	Y	Y	Y	
Y =Test applicable, Y1 = for 11kV and 3.3kV motors only																		
Note																		
This is an indicative list of tests/ checks. The manufacture is to furnish the detailed Quality Plan indicating the practices and procedure followed along with relevant supporting documents during QP finalization. However QP approval is not envisaged for 415V motors upto 50 KW.																		

Site Tests :

The following minimum tests/ checks shall be conducted at site. Any other tests/ checks as per the manufacturer's recommendation shall also be carried out

- i) Measurement of vibration.
- ii) Measurement of insulation resistance and polarization index
- iii) Measurement of full load current.
- iv) Test running of the motors, checking the temperature rise and identifying the hot spot etc.



TITLE

LV MOTORS**DATA SHEET-A**

SPECIFICATION NO.

VOLUME II B

SECTION II

REV NO. 00 DATE 28.09.2021

SHEET 1 OF 1

1.0	Design ambient temperature	:	50 °C
2.0	Maximum acceptable kW rating of LV motor	:	Upto 200KW
3.0	Installation (Indoors/ Outdoors)	:	As required
4.0	Degree Of Protection	:	IP55 (INDOOR), IPW55(OUTDOOR)
5.0	Cooling	:	TEFC
6.0	Details of supply system		
	a) Rated voltage (with variation)	:	415V ± 10%
	b) Rated frequency (with variation)	:	50 Hz (Variation: +3% To -5%)
	c) Combined voltage & freq. variation	:	10% (sum of absolute values)
	d) System fault level at rated voltage	:	50 kA for 1 sec
	e) Short time rating for terminal box	:	50 kA for 0.25 sec
	f) LV System grounding	:	Solidly
7.0	Class of insulation	:	Class 'F', with temp rise limited to class B.
8.0	Minimum voltage for starting (As percentage of rated voltage)	:	80% of rated voltage
9.0	Power cables data	:	Shall be given during Detailed engg.
10.0	Earth Conductor Size & Material	:	Shall be given during Detailed engg.
11.0	Space heater supply (30KW & ABOVE)	:	240 V, 1Φ , 50 Hz
12.0	Rating up to which Single phase motor	:	Acceptable upto 0.20 Kw
13.0	TYPE OF STARTER PROVIDED IN MCC	:	DOL
14.0	Locked rotor current		
	a) Limit as percentage of FLC	:	As per IS 12615
	b) Permissible tolerance, if any	:	
15.0	Additional tests	:	As per QP
16.0	Flame-proof motor		
	a) Enclosure suitable (As per IS:2148)	:	As per requirement
	b) Classification of Hazardous area (As per IS: 5572 part-I)	:	As per requirement
	c) Degree of protection	:	IP65
17.0	Makes	:	AS PER ANNEXURE-I
19.0	Paint shade	:	RAL 7032 (Siemens Grey).
20.0	Efficiency class	:	IE3

NOTE :1. Also detailed Customer spec. for Motors is to be referred as enclosed with technical spec.

	TITLE	SPECIFICATION NO.
	<p style="text-align: center;">LV MOTOR</p> <p style="text-align: center;">DATA SHEET - C</p>	VOLUME _____ II B
		SECTION II
		REV NO. 00 DATE
	SHEET 1 OF 2	

S. No.	Description	Data to be filled by successful bidder
A.	General	
1	Manufacturer & country of origin	
2	Motor type	
3	Type of starting	
4	Name of the equipment driven by motor & Quantity	
5	Maximum Power requirement of driven equipment	
6	Rated speed of Driven Equipment	
7	Design ambient temperature	
B.	Design and Performance Data	
1	Frame size & type designation	
2	Type of duty	
3	Rated Voltage	
4	Permissible variation for	
5	a) Voltage	
6	b) Frequency	
7	c) Combined voltage & frequency	
8	Rated output at design ambient temp (by resistance method)	
9	Synchronous speed & Rated slip	
10	Minimum permissible starting voltage	
11	Starting time in sec with mechanism coupled	
12	a) At rated voltage	
13	b) At min starting voltage	
14	Locked rotor current as percentage of FLC (including IS tolerance)	
15	Torque	
	a) Starting	
	b) Maximum	
16	Permissible temp rise at rated output over ambient temp & method	
17	Noise level at 1.0 m (dB)	
18	Amplitude of vibration	
19	Efficiency & P.F. at rated voltage & frequency	
	a) At 100% load	
	c) At 75% load	

NAME OF VENDOR			SEAL	REV.	
NAME	SIGNATURE	DATE			

	TITLE	SPECIFICATION NO.
	<p style="text-align: center;">LV MOTOR</p> <p style="text-align: center;">DATA SHEET - C</p>	VOLUME _____ II B
		SECTION II
		REV NO. 00 DATE
		SHEET 2 OF 2

S. No.	Description	Data to be filled by successful bidder
	c) At starting	
C.	Constructional Features	
1	Method of connection of motor driven equipment	
2	Applicable Standard	
3	DOP of Enclosure	
4	Method of cooling	
5	Class of insulation	
6	Main terminal box	
	a) Type	
	b) Power Cable details (Conductor, size, armour/unarmour)	
	c) Cable Gland & lugs details (Size, type & material)	
	d) Permissible Fault level (kArms & duration in sec)	
7	Space heater details (Voltage & watts)	
8	Flame proof motor details (if applicable)	
	a) Enclosure	
	b) suitability for hazardous area	
	i Zone	O / I / II
	ii Group	IIA / IIB / IIC
9	No. of Stator winding	
10	Winding connection	
11	Kind of rotor winding	
12	Kind of bearings	
13	Direction of rotation when viewed from NDE	
14	Paint Shade & type	
15	Net weight of motor	
16	Outline mounting drawing No (To be enclosed as annexure)	
D.	Characteristic curves/ drawings (To be enclosed for motors of rating $\geq 55KW$)	
	a) Torque speed characteristic	
	b) Thermal withstand characteristic	
	c) Current vs time	
	d) Speed vs time	

NAME OF VENDOR			SEAL	REV.	
NAME	SIGNATURE	DATE			



TITLE :
GENERAL TECHNICAL REQUIREMENTS

FOR

LV MOTORS

SPECIFICATION NO.
PE-SS-999-506-E101
VOLUME NO. : **II-B**
SECTION : **II**
REV NO. : **00** DATE : 29/08/2005
SHEET : 1 OF 1

GENERAL TECHNICAL REQUIREMENTS

FOR

LV MOTORS

SPECIFICATION NO.: PE-SS-999-506-E101 Rev 00



TITLE :
GENERAL TECHNICAL REQUIREMENTS

FOR

LV MOTORS

SPECIFICATION NO.
PE-SS-999-506-E101
VOLUME NO. : **II-B**
SECTION : **II**
REV NO. : **00** DATE : 29/08/2005
SHEET : 1 OF 4

1.0 INTENT OF SPECIFICATION

The specification covers the design, materials, constructional features, manufacture, inspection and testing at manufacturer's work, and packing of Low voltage (LV) squirrel cage induction motors along with all accessories for driving auxiliaries in thermal power station.

Motors having a voltage rating of below 1000V are referred to as low voltage (LV) motors.

2.0 CODES AND STANDARDS

Motors shall fully comply with latest edition, including all amendments and revision, of following codes and standards:

IS:325	Three phase Induction motors
IS : 900	Code of practice for installation and maintenance of induction motors
IS: 996	Single phase small AC and universal motors
IS: 4722	Rotating Electrical machines
IS: 4691	Degree of Protection provided by enclosures for rotating electrical machines
IS: 4728	Terminal marking and direction of rotation rotating electrical machines
IS: 1231	Dimensions of three phase foot mounted induction motors
IS: 8789	Values of performance characteristics for three phase induction motors
IS: 13555	Guide for selection and application of 3-phase A.C. induction motors for different types of driven equipment
IS: 2148	Flame proof enclosures for electrical appliance
IS: 5571	Guide for selection of electrical equipment for hazardous areas
IS: 12824	Type of duty and classes of rating assigned
IS: 12802	Temperature rise measurement for rotating electrical machines
IS: 12065	Permissible limits of noise level for rotating electrical machines
IS: 12075	Mechanical vibration of rotating electrical machines

In case of imported motors, motors as per IEC-34 shall also be acceptable.

3.0 DESIGN REQUIREMENTS

3.1 Motors and accessories shall be designed to operate satisfactorily under conditions specified in data sheet-A and Project Information, including voltage & frequency variation of supply system as defined in Data sheet-A

3.2 Motors shall be continuously rated at the design ambient temperature specified in Data Sheet-A and other site conditions specified under Project Information
Motor ratings shall have at least a 15% margin over the continuous maximum demand of the driven equipment, under entire operating range including voltage & frequency variation specified above.

3.3 Starting Requirements

3.3.1 Motor characteristics such as speed, starting torque, break away torque and starting time shall be properly co-ordinated with the requirements of driven equipment. The accelerating torque at any speed with the minimum starting voltage shall be at least 10% higher than that of the driven equipment.

3.3.2 Motors shall be capable of starting and accelerating the load with direct on line starting without exceeding acceptable winding temperature.



TITLE :
GENERAL TECHNICAL REQUIREMENTS

FOR

LV MOTORS

SPECIFICATION NO.
PE-SS-999-506-E101
VOLUME NO. : **II-B**
SECTION : **II**
REV NO. : **00** DATE : 29/08/2005
SHEET : 2 OF 4

The limiting value of voltage at rated frequency under which a motor will successfully start and accelerate to rated speed with load shall be taken to be a constant value as per Data Sheet - A during the starting period of motors.

3.3.3 The following frequency of starts shall apply

- i) Two starts in succession with the motor being initially at a temperature not exceeding the rated load temperature.
- ii) Three equally spread starts in an hour the motor being initially at a temperature not exceeding the rated load operating temperature. (not to be repeated in the second successive hour)
- iii) Motors for coal conveyor and coal crusher application shall be suitable for three consecutive hot starts followed by one hour interval with maximum twenty starts per day and shall be suitable for minimum 20,000 starts during the life time of the motor

3.4 **Running Requirements**

3.4.1 Motors shall run satisfactorily at a supply voltage of 75% of rated voltage for 5 minutes with full load without injurious heating to the motor.

3.4.2 Motor shall not stall due to voltage dip in the system causing momentary drop in voltage upto 70% of the rated voltage for duration of 2 secs.

3.5 **Stress During bus Transfer**

3.5.1 Motors shall withstand the voltage, heavy inrush transient current, mechanical and torque stress developed due to the application of 150% of the rated voltage for at least 1 sec. caused due to vector difference between the motor residual voltage and the incoming supply voltage during occasional auto bus transfer.

3.5.2 Motor and driven equipment shafts shall be adequately sized to satisfactorily withstand transient torque under above condition.

3.6 Maximum noise level measured at distance of 1.0 metres from the outline of motor shall not exceed the values specified in IS 12065.

3.7 The max. vibration velocity or double amplitude of motors vibration as measured at motor bearings shall be within the limits specified in IS: 12075.

4.0 **CONSTRUCTIONAL FEATURES**

4.1 Indoor motors shall conform to degree of protection IP: 54 as per IS: 4691. Outdoor or semi-indoor motors shall conform to degree of protection IP: 55 as per IS: 4691 and shall be of weather-proof construction. Outdoor motors shall be installed under a suitable canopy

4.2 Motors upto 160KW shall have Totally Enclosed Fan Cooled (TEFC) enclosures, the method of cooling conforming to IC-0141 or IC-0151 of IS: 6362.

Motors rated above 160 KW shall be Closed Air Circuit Air (CACA) cooled

4.3 Motors shall be designed with cooling fans suitable for both directions of rotation.



TITLE :
GENERAL TECHNICAL REQUIREMENTS

FOR

LV MOTORS

SPECIFICATION NO.
PE-SS-999-506-E101
VOLUME NO. : **II-B**
SECTION : **II**
REV NO. : **00** DATE : 29/08/2005
SHEET : 3 OF 4

- 4.4. Motors shall not be provided with any electric or pneumatic operated external fan for cooling the motors.
- 4.5. Frames shall be designed to avoid collection of moisture and all enclosures shall be provided with facility for drainage at the lowest point.
- 4.6. In case Class 'F' insulation is provided for LV motors, temperature rise shall be limited to the limits applicable to Class 'B' insulation.
In case of continuous operation at extreme voltage limits the temperature limits specified in table-1 of IS:325 shall not exceed by more than 10°C.
- 4.7. **Terminals and Terminal Boxes**
- 4.7.1 Terminals, terminal leads, terminal boxes, windings tails and associated equipment shall be suitable for connection to a supply system having a short circuit level, specified in the Data Sheet-A.

Unless otherwise stated in Data Sheet-A, motors of rating 110 kW and above will be controlled by circuit breaker and below 110 kW by switch fuse-contactor. The terminal box of motors shall be designed for the fault current mentioned in data sheet "A".
- 4.7.2 unless otherwise specified or approved, phase terminal boxes of horizontal motors shall be positioned on the left hand side of the motor when viewed from the non-driving end.
- 4.7.3 Connections shall be such that when the supply leads R, Y & B are connected to motor terminals A B & C or U, V & W respectively, motor shall rotate in an anticlockwise direction when viewed from the non-driving end. Where such motors require clockwise rotation, the supply leads R, Y, B will be connected to motor terminals A, C, B or U W & V respectively.
- 4.7.4 Permanently attached diagram and instruction plate made preferably of stainless steel shall be mounted inside terminal box cover giving the connection diagram for the desired direction of rotation and reverse rotation.
- 4.7.5 Motor terminals and terminal leads shall be fully insulated with no bar live parts. Adequate space shall be available inside the terminal box so that no difficulty is encountered for terminating the cable specified in Data Sheet-A.
- 4.7.6 Degree of protection for terminal boxes shall be IP 55 as per IS 4691.
- 4.7.7 Separate terminal boxes shall be provided for space heaters.. If this is not possible in case of LV motors, the space heater terminals shall be adequately segregated from the main terminals in the main terminal box. Detachable gland plates with double compression brass glands shall be provided in terminal boxes.
- 4.7.8. Phase terminal boxes shall be suitable for 360 degree of rotation in steps of 90 degree for LV motors.
- 4.7.9 Cable glands and cable lugs as per cable sizes specified in Data Sheet-A shall be included. Cable lugs shall be of tinned Copper, crimping type.
- 4.8 Two separate earthing terminals suitable for connecting G.I. or MS strip grounding conductor of size given in Data Sheet-A shall be provided on opposite sides of motor frame. Each terminal box shall have a grounding terminal.



TITLE :
GENERAL TECHNICAL REQUIREMENTS

FOR





LV MOTORS

SPECIFICATION NO.
PE-SS-999-506-E101
VOLUME NO. : **II-B**
SECTION : **II**
REV NO. : **00** DATE : 29/08/2005
SHEET : 4 OF 4

- 4.9.1 Motors provided for similar drives shall be interchangeable.
- 4.9.2 Suitable foundation bolts are to be supplied alongwith the motors.
- 4.9.3 Motors shall be provided with eye bolts, or other means to facilitate safe lifting if the weight is 20Kgs. and above.
- 4.9.4 Necessary fitments and accessories shall be provided on motors in accordance with the latest Indian Electricity rules 1956.
- 4.9.5 All motors rated above 30 kW shall be provided with space heaters to maintain the motor internal air temperature above the dew point. Unless otherwise specified, space heaters shall be suitable for a supply of 240V AC, single phase, 50 Hz.
- 4.9.6 Name plate with all particulars as per IS: 325 shall be provided
- 4.9.7 Unless otherwise specified, the colour of finish shall be grey to Shade No. 631 and 632 as per IS:5 for motors installed indoor and outdoor respectively. The paint shall be epoxy based and shall be suitable for withstanding specified site conditions.
- 5.0 INSPECTION AND TESTING**
- 5.1 All materials, components and equipments covered under this specification shall be procured, manufactured, as per the BHEL standard quality plan No. PED-506-00-Q-006/0 and PED-506-00-Q-007/2 enclosed with this specification and which shall be complied.
- 5.2 LV motors of type-tested design shall be provided. Valid type test reports not more than 5 year shall be furnished. In the absence of these, type tests shall have to be conducted by manufacturer without any commercial implication to purchaser.
- 5.3 All motors shall be subjected to routine tests as per IS: 325 and as per BHEL standard quality plan.
- 5.4 Motors shall also be subjected to additional tests, if any, as mentioned in Data Sheet A.
- 6.0 DRAWINGS TO BE SUBMITTED AFTER AWARD OF CONTRACT**
- a) OGA drawing showing the position of terminal boxes, earthing connections etc.
- b) Arrangement drawing of terminal boxes.
- c) Characteristic curves:
(To be given for motor above 55 kW unless otherwise specified in Data Sheet).
- i) Current vs. time at rated voltage and minimum starting voltage.
- ii) Speed vs. time at rated voltage and minimum starting voltage.
- iii) Torque vs. speed at rated voltage and minimum voltage.
For the motors with solid coupling the above curves i), ii), iii) to be furnished for the motors coupled with driven equipment. In case motor is coupled with mechanical equipment by fluid coupling, the above curves shall be furnished with and without coupling.
- iv) Thermal withstand curve under hot and cold conditions at rated voltage and max. permissible voltage.

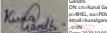
	MANUFACTURER/ BIDDER/ SUPPLIER NAME & ADDRESS	STANDARD QUALITY PLAN			SPEC. NO :		DATE:		
		CUSTOMER :			QP NO.: PE-QP-999-Q-006, REV-02		DATE: 17.04.2020		
		PROJECT:			PO NO.:		DATE:		
		ITEM: AC ELECT. MOTORS UPTO 55KW (LV (415V))		SYSTEM:		SECTION: II		SHEET 1 of 2	

S. NO.	COMPONENT & OPERATIONS	CHARACTERISTICS	CLASS	TYPE OF CHECK	QUANTUM OF CHECK		REFERENCE DOCUMENT	ACCEPTANCE NORMS	FORMAT OF RECORD	AGENCY	REMARKS			
					M	C/ N						D	M	C
1	2	3	4	5	6		7	8	9	*	**			
1.0	ASSEMBLY	1.WORKMANSHIP	MA	VISUAL	100%	-	MFG. SPEC.	MFG. SPEC.	LOG BOOK	P	-	-		
		2.DIMENSIONS	MA	VISUAL	100%	-	MFG. DRG./ MFG. SPEC.	MFG. DRG./ MFG. SPEC.	LOG BOOK	P	-	-		
		3.CORRECTNESS COMPLETENESS TERMINATIONS/ MARKING/ COLOUR CODE	MA	VISUAL	100%	-	MFG.SPEC./	MFG.SPEC.	LOG BOOK	P	-	-		
2.0	PAINTING	1.SHADE	MA	VISUAL	SAMPLE	-	MFG. SPEC/ APPROVED DATASHEET	MFG. SPEC/ APPROVED DATASHEET	LOG BOOK	✓	P	V	-	
3.0	TESTS	1.ROUTINE TEST INCLUDING SPECIAL TEST	MA	VISUAL	100%	-	IS-325 / IS-12615/ APPROVED DATA SHEET	IS-325 / IS-12615/ APPROVED DATA SHEET	TEST/ INSPN. REPORT	✓	P	V*	-	* NOTE -1
		2.OVERALL DIMENSIONS & ORIENTATION	MA	MEASUREMENT & VISUAL	100%	-	APPROVED DRG/ DATA SHEET	APPROVED DRG/ DATA SHEET	TEST/ INSPN. REPORT	✓	P	V*	-	* NOTE -1 & NOTE-2

BHEL						BIDDER/ SUPPLIER		FOR CUSTOMER REVIEW & APPROVAL			
ENGINEERING			QUALITY			Sign & Date		Doc No:			
Prepared by:	Sign & Date	Name	Checked by:	Sign & Date	Name	Seal	Sign & Date		Name		Seal
HEMA KUSHWAHA		HEMA KUSHWAHA	KUNAL GANDHI		KUNAL GANDHI						
PRAVEEN DUTTA		PRAVEEN DUTTA	RITESH KUMAR JAISWAL		RITESH KUMAR JAISWAL						

	MANUFACTURER/ BIDDER/ SUPPLIER NAME & ADDRESS	STANDARD QUALITY PLAN				SPEC. NO :				DATE:			
		CUSTOMER :				QP NO.: PE-QP-999-Q-006, REV-02				DATE: 17.04.2020			
		PROJECT:				PO NO.:				DATE:			
		ITEM: AC ELECT. MOTORS UPTO 55KW (LV (415V))		SYSTEM:		SECTION: II				SHEET 2 of 2			

		3.NAMEPLATE DETAILS	MA	VISUAL	100%	-	IS-325 / IS-12615 / APPROVED DATA SHEET	SAME AS COL. 7	TEST/ INSPN. REPORT	✓	P	V	-	
4.0	PACKING	SURFACE FINISH & COMPLETENESS	MA	VISUAL	100%	100%	AS PER MFG. STANDARD / (#)	AS PER MFG. STANDARD / (#).	INSPC. REPORT	✓	P	W	-	(#) REFER NOTE-8

NOTES:

1. Routine tests on 100% motors shall be done by the vendor. However, BHEL/ Customer shall witness routine tests on random samples. The sampling plan shall be mutually agreed upon.
2. For exhaust/ventilation fan motors of rating up to 1.5 KW, only routine test certificates shall be furnished for scrutiny.
3. In case test certificates for these tests on similar type, size and design of motor from independent laboratory are available, the same is valid for 5 years.
4. BHEL reserves the right to perform repeat test, if required.
5. After packing and prior to issue MDCC, photographs of items to be despatched shall be sent to BHEL for review.
6. In case of any changes in QP commented by customer at contract stage, same shall be carried out by bidder without any implication to BHEL/ Customer.
7. Project specific QP to be developed based on customer requirement.
8. For export job, BHEL technical specification for seaworthy packing to be followed.
9. Packing shall be suitable for storage at site in tropical climate conditions.
10. Latest revision/ year of issue of all the standards (IS/ ASME/ IEC etc.) indicated in QP shall be referred.



LEGENDS:

*RECORDS, IDENTIFIED WITH "TICK"(✓) SHALL BE ESSENTIALLY INCLUDED BY SUPPLIER IN QA DOCUMENTATION,
 ** **M:** SUPPLIER/ MANUFACTURER/ SUB-SUPPLIER, **B:** MAIN SUPPLIER/ BHEL/ THIRD PARTY INSPECTION AGENCY, **C:** CUSTOMER,
P: PERFORM, **W:** WITNESS, **V:** VERIFICATION, AS APPROPRIATE
MA: MAJOR, **MI:** MINOR, **CR:** CRITICAL
D: DOCUMENTATION

BHEL						BIDDER/ SUPPLIER		FOR CUSTOMER REVIEW & APPROVAL			
ENGINEERING			QUALITY			Sign & Date		Doc No:			
	Sign & Date	Name		Sign & Date	Name	Seal		Sign & Date	Name	Seal	
Prepared by:	HEMA KUSHWAHA	HEMA KUSHWAHA	Checked by:		KUNAL GANDHI			Reviewed by:			
Reviewed by:	PRAVEEN DUTTA	PRAVEEN DUTTA	Reviewed by:	RITESH KUMAR JAISWAL	RITESH KUMAR JAISWAL			Approved by:			

	MANUFACTURER/ BIDDER/ SUPPLIER NAME & ADDRESS	STANDARD QUALITY PLAN		SPEC. NO :		DATE:17.04.2020 SHEET 1 OF 9
		CUSTOMER :		QP NO.: PE-QP-999-Q-007, REV-04		
		PROJECT:		PO NO.:		
		ITEM: AC ELECT. MOTORS 55 KW & ABOVE (LV (415V))		SYSTEM:		
		SECTION: II				

SI No.	Component & Operations	Characteristics	Class	Type of Check	Quantum Of check		Reference Document	Acceptance NORMS	FORMAT OF RECORD	AGENCY				
					M	C/N				D	M	C	N	
1.0	RAW MATERIAL & BOUGHT OUT CONTROL													
1.1	SHEET STEEL, PLATES, SECTION, EYEBOLTS	1.SURFACE CONDITION	MA	VISUAL	100%	-	-	FREE FROM BLINKS, CRACKS, WAVINESS ETC	LOG BOOK		P	-	-	
		2.DIMENSIONS	MA	MEASUREMENT	SAMPLE	-	MANUFACTURER'S DRG./SPEC	MANUFACTURER'S DRG./SPEC	LOG BOOK		P	-	-	
		3.PROOF LOAD TEST (EYE BOLT)	MA	MECH. TEST	SAMPLE	-	MANUFACTURER'S DRG./SPEC	MANUFACTURER'S DRG./SPEC	TEST REPORT		P/V	-	-	
1.2	HARDWARES	1.SURFACE CONDITION	MA	VISUAL	100%	-	-	FREE FROM CRACKS, UN-EVENNESS ETC.	TEST REPORT		P	-	-	
		2.PROPERTY CLASS	MA	VISUAL	SAMPLES	-	MANUFACTURER'S DRG./SPEC	MANUFACTURER'S DRG./SPEC	TC		P/V	-	-	PROPERTY CLASS MARKING SHALL BE CHECKED BY THE VENDOR
1.3	CASTING	1.SURFACE CONDITION	MA	VISUAL	100%	-	MANUFACTURER'S DRG./SPEC	FREE FROM CRACKS, BLOW HOLES ETC.	LOG BOOK		P/V	-	-	
		2.CHEM. & PHY. PROP.	MA	CHEM & MECH TEST	1/HEAT NO.	-	MANUFACTURER'S DRG./SPEC	MANUFACTURER'S DRG./SPEC	TC		P/V	-	-	HEAT NO. SHALL BE VERIFIED
		3.DIMENSIONS	MA	MEASUREMENT	100%	-	MANUFACTURER'S DRG.	MANUFACTURER'S DRG.	LOG BOOK		P/V	-	-	
1.4	PAINT & VARNISH	1.MAKE, SHADE, SHELF LIFE & TYPE	MA	VISUAL	100%	CONTINUOUS	MANUFACTURER'S DRG./SPEC	MANUFACTURER'S DRG./SPEC	LOG BOOK		P/V	-	-	

BHEL					
ENGINEERING			QUALITY		
	Sign & Date	Name		Sign & Date	Name
Prepared by:	HEMA KUSHWAHA	HEMA KHUSHWAHA	Checked by:		KUNAL GANDHI
Reviewed by:	 PRAVEEN DUTTA	PRAVEEN DUTTA	Reviewed by:	 RITESH KUMAR JAISWAL	R K JAISWAL

BIDDER/ SUPPLIER	
Sign & Date	
Seal	

FOR CUSTOMER REVIEW & APPROVAL			
Doc No:			
	Sign & Date	Name	Seal
Reviewed by:			
Approved by:			

	MANUFACTURER/ BIDDER/ SUPPLIER NAME & ADDRESS	STANDARD QUALITY PLAN		SPEC. NO. :		
		CUSTOMER :		QP NO.: PE-QP-999-Q-007, REV-04		DATE:17.04.2020
		PROJECT:		PO NO.:		
		ITEM: AC ELECT. MOTORS 55 KW & ABOVE (LV (415V))		SYSTEM:		SECTION: II

SI No.	Component & Operations	Characteristics	Class	Type of Check	Quantum Of check		Reference Document	Acceptance NORMS	FORMAT OF RECORD		AGENCY			
					M	C/N			9	.	**	D	M	
1.5	SHAFT (FORGED OR ROLLED)	1. SURFACE COND.	MA	VISUAL	100%	-	-	FREE FROM VISUAL DEFECTS	LOG BOOK		P	-	-	VENDOR'S APPROVAL IDENTIFICATION SHALL BE MAINTAINED
		2. CHEM. & PHYSICAL PROPERTIES	MA	CHEM. & PHYSICAL TESTS	1/HEAT NO. OR HEAT TREATMENT BATCH NO	-	MANUFACTURER'S DRG./ SPEC.	MANUFACTURER'S DRG./ STD.	TC		P/V	-	-	
		3. DIMENSIONS	MA	MEASUREMENT	100%	-	MANUFACTURER'S DRG./ SPEC.	MANUFACTURER'S DRG.	LOG BOOK		P/V	-	-	
		4. INTERNAL FLAWS	CR	ULTRASONIC TEST	100%	-	ASTM-A388	MANUFACTURER'S STD.	INSPECTION REPORT	✓	P/W	V	-	
1.6	SPACE HEATERS, CONNECTORS, TERMINAL BLOCKS, CABLES, CABLE LUGS, CARBON BRUSH TEMP. DETECTORS, RTD, BTD'S	1. MAKE & RATING	MA	VISUAL	100%	-	MANUFACTURER'S DRG./STD.	MANUFACTURER'S DRG./STD.	INSPECTION REPORT		P/V	-	-	
		2. PHYSICAL COND.	MA	VISUAL	100%	-	MANUFACTURER'S DRG./STD.	NO PHYS. DAMAGE, NO ELECTRICAL DISCONTINUITY	INSPECTION REPORT		P/V	-	-	
		3. DIMENSIONS (WHEREVER APPLICABLE)	MA	MEASUREMENT	SAMPLE	-	MANUFACTURER'S DRG./ STD	MANUFACTURER'S DRG. / STD.	INSPECTION REPORT		P/V	-	-	
		4. PERFORMANCE/ CALIBRATION	MA	TEST	100%	-	MANUFACTURER'S DRG/ STD	MANUFACTURER'S DRG. / STD.	TEST REPORT		P/V	-	-	





BHEL					
ENGINEERING			QUALITY		
	Sign & Date	Name		Sign & Date	Name
Prepared by:	HEMA KUSHWAHA	HEMA KHUSHWAHA	Checked by:		KUNAL GANDHI
Reviewed by:	PRAVEEN DUTTA	PRAVEEN DUTTA	Reviewed by:	RITESH KUMAR JAISWAL	R K JAISWAL

BIDDER/ SUPPLIER	
Sign & Date	
Seal	

FOR CUSTOMER REVIEW & APPROVAL			
Doc No:			
	Sign & Date	Name	Seal
Reviewed by:			
Approved by:			

	MANUFACTURER/ BIDDER/ SUPPLIER NAME & ADDRESS	STANDARD QUALITY PLAN		SPEC. NO.:	
		CUSTOMER :		QP NO.: PE-QP-999-Q-007, REV-04	
		PROJECT:		PO NO.:	
		ITEM: AC ELECT. MOTORS 55 KW & ABOVE (LV (415V))	SYSTEM:	SECTION: II	DATE:17.04.2020
				SHEET 3 OF 9	

SI No.	Component & Operations	Characteristics	Class	Type of Check	Quantum Of check		Reference Document	Acceptance NORMS	FORMAT OF RECORD		AGENCY			
					M	CIN			9	.	**	D	M	C
1.7	OTHER INSULATING MATERIALS LIKE SLEEVES, BINDINGS CORDS, PAPERS, PRESS BOARDS ETC.	1. SURFACE COND. ETC.	MA	VISUAL	100%	-	-	NO VISUAL DEFECTS	TEST REPORT		P/V	-	-	
		2.DIMENSION(BORE DIA, WALL THICKNESS, BDV AS RECEIVED, BDV AFTER FOLDING AT 180°	MA	TEST	SAMPLE	-	MANUFACTURER'S STD.	MANUFACTURER'S STD.	LOG BOOK AND OR SUPPLIER'S TC		P/V	-	-	
1.8	SHEET STAMPING (PUNCHED)	1. SURFACE COND.	MA	VISUAL	100%	-	-	NO VISUAL DEFECTS (FREE FROM BURS)	LOG BOOK		P	-	-	
		2.DIMENSIONS INCLUDING BURS HEIGHT	MA	MEASUREMENT	SAMPLE	-	MANUFACTURER'S DRG.	MANUFACTURER'S DRG.	LOG BOOK		P/V	-	-	
		3. ACCEPTANCE TESTS	MA	ELECT. & MECH TESTS	SAMPLE	-	MANUFACTURER'S DRG./ STD.	MANUFACTURER'S DRG./ STD.	TC		P/V	-	-	
1.9	CONDUCTORS	1. SURFACE FINISH	MA	VISUAL	100%	-	-	FREE FROM VISUAL DEFECTS	LOG BOOK		*P/V	-	-	* MOTOR MANUFACTURER TO CONDUCT VISUAL CHECK FOR SURFACE FINISH ON RANDOM BASIS (10% SAMPLE) AT HIS WORKS AND MAINTAIN RECORD FOR VERIFICATION BY
		2.ELECT. PROP. & MECH. PROP	MA	ELECT. & MECH.TEST	SAMPLES	-	MANUFACTURER'S DRG./ SPEC.	MANUFACTURER'S / SPEC.	TC & VENDOR'S TEST REPORTS		P/V	-	-	



BHEL					
ENGINEERING			QUALITY		
	Sign & Date	Name		Sign & Date	Name
Prepared by:	 HEMA KUSHWAHA	HEMA KUSHWAHA	Checked by:	 KUNAL GANDHI	KUNAL GANDHI
Reviewed by:	 PRAVEEN DUTTA	PRAVEEN DUTTA	Reviewed by:	 RITESH KUMAR JAISWAL	R K JAISWAL

BIDDER/ SUPPLIER	
Sign & Date	
Seal	

FOR CUSTOMER REVIEW & APPROVAL			
Doc No:			
	Sign & Date	Name	Seal
Reviewed by:			
Approved by:			

	MANUFACTURER/ BIDDER/ SUPPLIER NAME & ADDRESS	STANDARD QUALITY PLAN		SPEC. NO. :	DATE:17.04.2020
		CUSTOMER :		QP NO.: PE-QP-999-Q-007, REV-04	
		PROJECT:		PO NO.:	
		ITEM: AC ELECT. MOTORS 55 KW & ABOVE (LV (415V))	SYSTEM:	SECTION: II	

SI No.	Component & Operations	Characteristics	Class	Type of Check	Quantum Of check		Reference Document	Acceptance NORMS	FORMAT OF RECORD		AGENCY		
					M	C/N			9	-	**	D	M
1.10	BEARINGS	3.DIMENSIONS	MA	MEASUREMENT	SAMPLES	-	MANUFACTURER'S DRG/ SPEC.	MANUFACTURER'S / SPEC.	LOG BOOK		P/V	-	-
		1.MAKE & TYPE	MA	VISUAL	100%	-	MANUFACTURER'S DRG/ APPROVED DATASHEET	MANUFACTURER'S DRG/ APPROVED DATASHEET	LOG BOOK		P/V	-	-
		2.DIMENSIONS	MA	MEASUREMENT	SAMPLE	-	APPROVED DATASHEET	APPROVED DATASHEET/ BEARING MANUF'S CATALOGUES	LOG BOOK		P/V	-	-
1.11	SLIP RING (WHEREVER APPLICABLE)	3.SURFACE FINISH	MA	VISUAL	100%	-	-	FREE FROM VISUAL DEFECTS	LOG BOOK		P/V	-	-
		1.SURFACE COND.	MA	VISUAL	100%	-	-	FREE FROM VISUAL DEFECTS	LOG BOOK		P	-	-
		2.DIMENSIONS	MA	MEASUREMENT	SAMPLE	-	MANUFACTURER'S DRG	MANUFACTURER'S DRG	LOG BOOK		P	-	-
		3.TEMP WITH-STAND CAPACITY	MA	ELECT.TEST	SAMPLE	-	MANUFACTURER'S STD./ APPROVED DATASHEET	MANUFACTURER'S STD./ APPROVED DATASHEET	LOG BOOK		P/V	-	-
1.12	OIL SEALS & GASKETS	4.HV/IR	MA	-DO-	100%	-	MANUFACTURER'S STD./ APPROVED DATASHEET	MANUFACTURER'S STD./ APPROVED DATASHEET	LOG BOOK		P/V	-	-
		1.MATERIAL OF GASKET	MA	VISUAL	100%	-	MANUFACTURER'S DRG/SPECS	MANUFACTURER'S DRG/ SPECS.	LOG BOOK		P	-	-
		2.SURFACE COND.	MA	VISUAL	100%	-	-	FREE FROM VISUAL DEFECTS	LOG BOOK		P	-	-
		3.DIMENSIONS	MA	MEASUREMENT	SAMPLE	-	MANUFACTURER'S DRG	MANUFACTURER'S DRG	LOG BOOK		P	-	-

BHEL					
ENGINEERING			QUALITY		
	Sign & Date	Name		Sign & Date	Name
Prepared by:	HEMA KUSHWAHA	HEMA KHUSHWAHA	Checked by:		KUNAL GANDHI
Reviewed by:	PRAVEEN DUTTA	PRAVEEN DUTTA	Reviewed by:	 RITESH KUMAR <small>Head, Quality Assurance</small>	R K JAISWAL

BIDDER/ SUPPLIER	
Sign & Date	
Seal	

FOR CUSTOMER REVIEW & APPROVAL			
Doc No:			
	Sign & Date	Name	Seal
Reviewed by:			
Approved by:			

	MANUFACTURER/ BIDDER/ SUPPLIER NAME & ADDRESS	STANDARD QUALITY PLAN		SPEC. NO :		DATE:17.04.2020
		CUSTOMER :		QP NO.: PE-QP-999-Q-007, REV-04		
		PROJECT:		PO NO.:		
		ITEM: AC ELECT. MOTORS 55 KW & ABOVE (LV (415V))		SYSTEM:		

SI No.	Component & Operations	Characteristics	Class	Type of Check	Quantum Of check		Reference Document	Acceptance NORMS	FORMAT OF RECORD		AGENCY						
					M	C/N			9	.	**	D	M	C	N		
2.0	IN PROCESS																
2.1	STATOR FRAME WELDING (IN CASE OF FABRICATED STATOR)	1.WORKMANSHIP & CLEANNESS	MA	VISUAL	100%	-	MANUFACTURER'S DRG	GOOD FINISH	LOG BOOK		P/W	-	-				
		2.DIMENSIONS	MA	MEASUREMENT	100%	-	MANUFACTURER'S DRG	MANUFACTURER'S DRG	LOG BOOK		P	-	-				
2.2	MACHINING	1.FINISH	MA	VISUAL	100%	-	-DO-	GOOD FINISH	LOG BOOK		P	-	-				
		2.DIMENSIONS	MA	MEASUREMENT	100%	-	MANUFACTURER'S DRG	MANUFACTURER'S DRG	LOG BOOK		P	-	-				
		3.SHAFT SURFACE FLOWS	MA	PT	100%	-	MANUFACTURER'S STD./ASTM-E165	MANUFACTURER'S STD./APPROVED DATASHEET.	LOG BOOK	✓	P	V	-				
2.3	PAINTING	1.SURFACE PREPARATION	MA	VISUAL	100%	-	MANUFACTURER'S STD./APPROVED DATASHEET	MANUFACTURER'S STD./APPROVED DATASHEET	LOG BOOK		P	-	-				
		2.PAINT THICKNESS (BOTH PRIMER & FINISH COAT)	MA	MEASUREMENT BY ELCOMETER	SAMPLE	-	MANUFACTURER'S STD./APPROVED DATASHEET	MANUFACTURER'S STD./APPROVED DATASHEET	LOG BOOK		P	-	-				
		3.SHADE	MA	VISUAL	SAMPLE	-	MANUFACTURER'S STD./APPROVED DATASHEET	MANUFACTURER'S STD./APPROVED DATASHEET	LOG BOOK		P	-	-				
		4.ADHESION	MA	CROSS CUTTING & TAPE TEST	SAMPLE	-	MANUFACTURER'S STD./APPROVED DATASHEET	MANUFACTURER'S STD./APPROVED DATASHEET	LOG BOOK		P	-	-				





BHEL				
ENGINEERING		QUALITY		
Sign & Date	Name	Sign & Date	Name	
Prepared by: HEMA KUSHWAHA	HEMA KHUSHWAHA	Checked by: 	KUNAL GANDHI	
Reviewed by: PRAVEEN DUTTA	PRAVEEN DUTTA	Reviewed by: RITESH KUMAR JAISWAL	R K JAISWAL	

BIDDER/ SUPPLIER	
Sign & Date	
Seal	

FOR CUSTOMER REVIEW & APPROVAL			
Doc No:			
Sign & Date	Name	Seal	
Reviewed by:			
Approved by:			

	MANUFACTURER/ BIDDER/ SUPPLIER NAME & ADDRESS	STANDARD QUALITY PLAN		SPEC. NO :		DATE:17.04.2020
		CUSTOMER :		QP NO.: PE-QP-999-Q-007, REV-04		
		PROJECT:		PO NO.:		
		ITEM: AC ELECT. MOTORS 55 KW & ABOVE (LV (415V))	SYSTEM:	SECTION: II	SHEET 6 OF 9	

SI No.	Component & Operations	Characteristics	Class	Type of Check	Quantum Of check		Reference Document	Acceptance NORMS	FORMAT OF RECORD		AGENCY		
					M	C/N			9	.	**	D	M
1	2	3	4	5	6		7	8					
2.4	SHEET STACKING	1.COMPLETENESS	MA	MEASUREMENT	SAMPLE	-	MANUFACTURER'S STD.	MANUFACTURER'S STD.	LOG BOOK		P	-	-
		2.COMPRESSION & TIGHTENING	MA	MEASUREMENT	100%	-	MANUFACTURER'S STD.	MANUFACTURER'S STD.	LOG BOOK		P	-	-
2.5	WINDING	1.COMPLETENESS	CR	VISUAL	100%	-	MANUFACTURER'S STD./APPROVED DATASHEET	MANUFACTURER'S STD./APPROVED DATASHEET	LOG BOOK		P	-	-
		2.CLEANLINESS	CR	VISUAL	100%	-	MANUFACTURER'S STD./APPROVED DATASHEET	MANUFACTURER'S STD./APPROVED DATASHEET	LOG BOOK		P	-	-
		3.IR-HV-IR	CR	ELECT. TEST	100%	-	IS-325//IS-12615/IEC-60034 PART-1	IS-325//IS-12615/IEC-60034 PART-1	TEST/INSPC. REPORT	✓	P	V	-
		4.RESISTANCE	CR	ELECT. TEST	100%	-	IS-325//IS-12615/IEC-60034 PART-1	IS-325//IS-12615/IEC-60034 PART-1	TEST/INSPC. REPORT	✓	P	V	-
		5.INTERTURN INSULATION	CR	ELECT. TEST	100%	-	IS-325//IS-12615/IEC-60034 PART-1	IS-325//IS-12615/IEC-60034 PART-1	TEST/INSPC. REPORT		P	-	-
2.6	IMPREGNATION	1.VISCOSITY	MA	PHY. TEST	AT STARTING	-	MANUFACTURER'S STANDARD	MANUFACTURER'S STANDARD	LOG BOOK		P	-	-
		2.TEMP. PRESSURE VACCUM	MA	PROCESS CHECK	CONTINUOUS	-	MANUFACTURER'S STANDARD	MANUFACTURER'S STANDARD	LOG BOOK		P	-	-
		3.NO. OF DIPS	MA	PROCESS CHECK	CONTINUOUS	-	MANUFACTURER'S STANDARD	MANUFACTURER'S STANDARD	LOG BOOK	✓	P	V	-
													THREE DIPS TO BE GIVEN



BHEL					
ENGINEERING			QUALITY		
	Sign & Date	Name		Sign & Date	Name
Prepared by:	 HEMA KUSHWAHA	HEMA KHUSHWAHA	Checked by:	 KUNAL GANDHI	KUNAL GANDHI
Reviewed by:	 PRAVEEN DUTTA	PRAVEEN DUTTA	Reviewed by:	 RITESH KUMAR	R K JAISWAL

BIDDER/ SUPPLIER	
Sign & Date	
Seal	

FOR CUSTOMER REVIEW & APPROVAL			
Doc No:			
	Sign & Date	Name	Seal
Reviewed by:			
Approved by:			

	MANUFACTURER/ BIDDER/ SUPPLIER NAME & ADDRESS	STANDARD QUALITY PLAN		SPEC. NO :	DATE:17.04.2020 SHEET 7 OF 9
		CUSTOMER :		QP NO.: PE-QP-999-Q-007, REV-04	
		PROJECT:		PO NO.:	
		ITEM: AC ELECT. MOTORS 55 KW & ABOVE (LV (415V))	SYSTEM:	SECTION: II	

SI No.	Component & Operations	Characteristics	Class	Type of Check	Quantum Of check		Reference Document	Acceptance NORMS	FORMAT OF RECORD		AGENCY			
					M	C/N			9	.	**	D	M	C
2.7	COMPLETE STATOR ASSEMBLY	4.DURATION 1.COMPACTNESS & CLEANLINESS	MA	PROCESS CHECK VISUAL	CONTINUOUS	-	MANUFACTURER'S STANDARD	MANUFACTURER'S STANDARD	LOG BOOK	✓	P	V	-	
2.8	BRAZING/COMPRESSION JOINT	1.COMPLETENESS	CR	VISUAL	100%	-	MANUFACTURER'S STANDARD	MANUFACTURER'S STANDARD	LOG BOOK		P	-	-	
2.9	COMPLETE ROTOR ASSEMBLY	2.SOUNDNESS	CR	MALLET TEST & UT	100%	-	MANUFACTURER'S STANDARD	MANUFACTURER'S STANDARD	TEST/INSPC. REPORT	✓	P	V	-	
		3.HV	MA	ELECT. TEST	100%	-	MANUFACTURER'S STANDARD	MANUFACTURER'S STANDARD	TEST/INSPC. REPORT	✓	P	V	-	
2.10	ASSEMBLY	1.RESIDUAL UNBALANCE	CR	DYN. BALANCE	100%	-	MANUFACTURER'S SPEC./ ISO 1940	MANUFACTURER'S DWG.	LOG BOOK		P	-	-	
		2.SOUNDNESS OF DIE CASTING	CR	ELECT. (GROWLER TEST)	100%	-	MANUFACTURER'S SPEC.	MANUFACTURER'S SPEC.	TEST/INSPC. REPORT	✓	P	V	-	
		1.ALIGNMENT	MA	MEAS.	100%	-	MANUFACTURER'S SPEC.	MANUFACTURER'S SPEC.	LOG BOOK		P	-	-	
		2.WORKMANSHIP	MA	VISUAL	100%	-	MANUFACTURER'S SPEC.	MANUFACTURER'S SPEC.	LOG BOOK		P	-	-	
		3.AXIAL PLAY	MA	MEAS.	100%	-	MANUFACTURER'S SPEC.	MANUFACTURER'S SPEC.	LOG BOOK	✓	P	V	-	
		4.DIMENSIONS	MA	MEAS.	100%	-	MANUFACTURER'S DRG./ MANUFACTURER'S SPEC.	MANUFACTURER'S DRG./ MANUFACTURER'S SPEC.	LOG BOOK		P	-	-	
		5.CORRECTNESS, COMPLETENESS TERMINATIONS/ MARKING/ COLOUR CODE	MA	VISUAL	100%	-	MANUFACTURER'S SPEC.	MANUFACTURER'S SPEC.	LOG BOOK		P	-	-	
		6. RTD, BTD & SPACE HEATER MOUNTING.	MA	VISUAL	100%	-	MANUFACTURER'S SPEC.	MANUFACTURER'S SPEC.	LOG BOOK	✓	P	V	-	

BHEL					
ENGINEERING			QUALITY		
Sign & Date	Name		Sign & Date	Name	
Prepared by: HEMA KUSHWAHA	HEMA KHUSHWAHA	Checked by: 	KUNAL GANDHI		
Reviewed by: PRAVEEN DUTTA	PRAVEEN DUTTA	Reviewed by: 	R K JAISWAL		

BIDDER/ SUPPLIER	
Sign & Date	
Seal	

FOR CUSTOMER REVIEW & APPROVAL			
Doc No:			
	Sign & Date	Name	Seal
Reviewed by:			
Approved by:			

	MANUFACTURER/ BIDDER/ SUPPLIER NAME & ADDRESS	STANDARD QUALITY PLAN		SPEC. NO :		DATE:17.04.2020 SHEET 8 OF 9
		CUSTOMER :		QP NO. : PE-QP-999-Q-007, REV-04		
		PROJECT:		PO NO.:		
		ITEM: AC ELECT. MOTORS 55 KW & ABOVE (LV (415V))	SYSTEM:	SECTION: II		

SI No.	Component & Operations	Characteristics	Class	Type of Check	Quantum Of check		Reference Document	Acceptance NORMS	FORMAT OF RECORD		AGENCY			
					M	C/N			9	.	**	D	M	C
3.0	TESTS	1.TYPE TESTS INCLUDING SPECIAL TESTS	MA	ELECT.TEST	1/TYPE/SIZE	1/TYPE/SIZE	IS-325//IS-12615/APPROVED DATASHEET	IS-325//IS-12615/APPROVED DATASHEET	TEST REPORT	✓	P	W*	-	* NOTE - 1
		2.ROUTINE TESTS INCLUDING SPECIAL TEST	MA	ELECT.TEST	100%	-	IS-325//IS-12615/APPROVED DATASHEET	IS-325//IS-12615/APPROVED DATASHEET	TEST REPORT	✓	P	√ ^s	-	^s NOTE - 2
		3.VIBRATION & NOISE LEVEL	MA	ELECT.TEST	100%	-	IS: 12075 / IEC 60034-14 & IS-12065	IS: 12075 / IEC 60034-14 & IS-12065	TEST REPORT	✓	P	√ ^s	-	^s NOTE - 2
		4.OVERALL DIMENSIONS AND ORIENTATION	MA	MEASUREMENT & VISUAL	100%	100%	APPROVED DRG/DATA SHEET	APPROVED DRG/DATA SHEET &	TEST/INSPC. REPORT	✓	P	W	-	
		5.DEGREE OF PROTECTION	MA	ELECT. & MECH. TEST	1/TYPE/ SIZE	-	IEC 60034-5/IS-12615	APPROVED DATASHEET	TC	✓	P	V	-	TC FROM AN INDEPENDENT LABORATORY, REFER NOTE-3
		6. MEASUREMENT OF RESISTANCE OF RTD & BTD	MA	ELECT. & MECH. TEST	100%	-	IS-325//IS-12615/IEC-60034 PART-1/IS: 12802	IS-325//IS-12615/IEC-60034 PART-1/IS: 12802	TC	✓	P	√ ^s	-	^s NOTE - 2
		7. MEASUREMENT OF RESISTANCE, IR OF SPACE HEATER	MA	ELECT. & MECH. TEST	100%	-	IS-325//IS-12615/IEC-60034 PART-1	IS-325//IS-12615/IEC-60034 PART-1	TC	✓	P	√ ^s	-	^s NOTE - 2
		8. NAME PLATE DETAILS	MA	VISUAL	100%	-	IS-325//IS-12615& DATA SHEET	IS-325//IS-12615 & DATA SHEET	TEST/INSPC. REPORT	✓	P	√ ^s	-	^s NOTE - 2
		9.EXPLOSION FLAME PROOF NESS (IF SPECIFIED)	MA	EXPLOSION FLAME PROOF TEST	1/TYPE	-	IS 2148 / IEC 60079-1	IS 2148 / IEC 60079-1	TC	✓	P	V	-	TC FROM AN INDEPENDENT LABORATORY, REFER NOTE-3
		10. PAINT SHADE, THICKNESS & FINISH	MA	VISUAL & MEASUREMENT BY ELKOMETER	SAMPLE	SAMPLE	APPROVED DATASHEET	APPROVED DATASHEET	TC	✓	P	W ^s	-	SAMPLING PLAN TO BE DECIDED BY INSPECTION AGENCY ^s NOTE - 2

BHEL					
ENGINEERING			QUALITY		
	Sign & Date	Name		Sign & Date	Name
Prepared by:	HEMA KUSHWAHA	HEMA KUSHWAHA	Checked by:		KUNAL GANDHI
Reviewed by:	PRAVEEN DUTTA	PRAVEEN DUTTA	Reviewed by:	RITESH KUMAR JAISWAL	R K JAISWAL

BIDDER/ SUPPLIER	
Sign & Date	
Seal	

FOR CUSTOMER REVIEW & APPROVAL			
Doc No:			
	Sign & Date	Name	Seal
Reviewed by:			
Approved by:			

	MANUFACTURER/ BIDDER/ SUPPLIER NAME & ADDRESS	STANDARD QUALITY PLAN		SPEC. NO.:	DATE:17.04.2020
		CUSTOMER :		QP NO.: PE-QP-999-Q-007, REV-04	
		PROJECT:		PO NO.:	
		ITEM: AC ELECT. MOTORS 55 KW & ABOVE (LV (415V))		SYSTEM:	SECTION: II





SI No.	Component & Operations	Characteristics	Class	Type of Check	Quantum Of check		Reference Document	Acceptance NORMS	FORMAT OF RECORD		AGENCY			
					M	C/N			9	.	**	M	C	N
4.0	PACKING	SURFACE FINISH & COMPLETENESS	MA	VISUAL	100%	100%	AS PER MANUFACT. STANDARD / (#)	AS PER MANUFACT. STANDARD / (#)	INSPC. REPORT	✓	P	W	-	(#): REFER NOTE-8

NOTES:

- 1 DEPENDING UPON THE SIZE AND CRITICALLY, WITNESSING BY BHEL SHALL BE DECIDED.
- 2 ROUTINE TESTS ON 100% MOTORS SHALL BE DONE BY THE VENDOR. HOWEVER, BHEL/CUSTOMER SHALL WITNESS ROUTINE TESTS ON RANDOM SAMPLES. THE SAMPLING PLAN SHALL BE MUTUALLY AGREED UPON.
- 3 IN CASE TEST CERTIFICATES FOR THESE TESTS ON SIMILAR TYPE, SIZE AND DESIGN OF MOTOR FROM INDEPENDENT LABORATORY ARE AVAILABLE, THE SAME IS VALID FOR 5 YEARS.
- 4 BHEL RESERVES THE RIGHT TO PERFORM REPEAT TEST, IF REQUIRED.
- 5 AFTER PACKING AND PRIOR TO ISSUE MDCC, PHOTOGRAPHS OF ITEMS TO BE DESPATCHED SHALL BE SENT TO BHEL PURCHASE GROUP FOR REVIEW.
- 6 IN CASE , ANY CHANGES IN QP COMMENTED BY CUSTOMER AT CONTRACT STAGE SHALL BE CARRIED OUT BY BIDDER WITHOUT ANY IMPLICATION TO BHEL/ CUSTOMER.
- 7 PROJECT SPECIFIC QP TO BE DEVELOPED BASED ON CUSTOMER REQUIREMENT.
- 8 FOR EXPORT JOB, BHEL TECHNICAL SPECIFICATION FOR SEAWORTHY PACKING TO BE FOLLOWED.
- 9 PACKING SHALL BE SUITABLE FOR STORAGE AT SITE IN TROPICAL CLIMATE CONDITIONS.
- 10 LATEST REVISION/ YEAR OF ISSUE OF ALL THE STANDARDS (IS/ ASME/ IEC ETC.) INDICATED IN QP SHALL BE REFERRED.

LEGENDS:

*RECORDS, IDENTIFIED WITH "TICK"(✓) SHALL BE ESSENTIALLY INCLUDED BY SUPPLIER IN QA DOCUMENTATION,
 ** M: SUPPLIER/ MANUFACTURER/ SUB-SUPPLIER, B: MAIN SUPPLIER/ BHEL/ THIRD PARTY INSPECTION AGENCY, C: CUSTOMER,
 P: PERFORM, W: WITNESS, V: VERIFICATION, AS APPROPRIATE
 MA: MAJOR, MI: MINOR, CR: CRITICAL
 D: DOCUMENT

BHEL					
ENGINEERING			QUALITY		
	Sign & Date	Name		Sign & Date	Name
Prepared by:		HEMA KUSHWAHA	Checked by:		KUNAL GANDHI
Reviewed by:		PRAVEEN DUTTA	Reviewed by:		R K JAISWAL

BIDDER/ SUPPLIER	
Sign & Date	
Seal	

FOR CUSTOMER REVIEW & APPROVAL			
Doc No.:	Sign & Date	Name	Seal
Reviewed by:			
Approved by:			



SECTION-3.17: CABLING ACCESSORIES

1.0.0 INTENT OF SPECIFICATION

SECTION-II

This section covers the requirements of cabling accessories. List of major items shall include the following:

- Cable joints & terminations
- Cable glands
- Cable lugs
- Camps
- Tags
- Conduits & Pipes
- Junction boxes

2.0.0 CODES AND STANDARDS

The equipment to be furnished under this specification shall be in accordance with the applicable section of the latest version of the following Standards except where modified and /or supplemented by this specification.

- a) VDE 0278 : Joints and Terminations
- b) IS: 13573 : Joints and Terminations for polymeric cables for working voltages from 6.6 KV up to and including 33 KV-Performance requirements and type tests.
- c) BS:6121 : Mechanical cable glands (Part 1 –Specification for metallic glands)
- d) IS: 12943 : Brass Glands for PVC Cables
- e) IS:8309 : Specification for compression type tubular terminal ends for aluminium conductors of insulated cables.

3.0.0 TECHNICAL REQUIREMENTS

3.1.0 Joints & terminations

3.1.1 Termination and jointing kits shall be of proven design and make which have already been extensively used and fully type tested. Kits shall be complete with all accessories and consumables required for complete termination or jointing. Copper cable lugs & jointing ferrules for straight through joints shall form part of the kit.

3.1.2 Termination and jointing kits shall be suitable for the following types of cables as per IS.

- 11 KV unearthed grade cable
- 1.1 KV grade power cables

3.1.3 Termination kits shall be 'elastimold' or 'Push on type' or 'heat shrinkable type'. Jointing kits shall be 'Tapex type' or 'heat shrinkable type'.

3.1.4 Straight through joint and termination shall be capable of withstanding the fault level of 44KA for HT Cables.

3.1.5 Straight through joints shall be protected against mechanical damage, rodent and termite attack. It shall be suitable for directly buried cables.



3.2.0 Cable glands

Cables shall be terminated using cable glands suitable for the voltage grade of cables. Cable glands shall be heavy duty brass machine finished and tinned. Cable glands shall be supplied with neoprene seal and earth lugs suitable for the fault capacity of the armour of the installed cables. Cable glands shall be double compression type for armoured cables. For flame proof equipment cable glands shall be of flame proof type.

3.3.0 Cable lugs

3.3.1 Cable lugs shall be of aluminium for aluminium cables and tinned copper for copper cables. Thickness of tinning shall be not less than 10 microns Type of end connection shall be solderless crimping type.

3.3.2 Cable lugs for conductors of power cables shall be "heavy duty" type. The type & size of cable lugs for power cables shall be selected according to the number and sizes of strands of the cable.

3.3.3 Solder less crimping of terminals shall be done by using corrosion inhibiting compound. Cable lugs for control cable termination shall be insulated. These lugs shall be pin type/flat type/ ring type/U Type to suit the terminals provided in the panels.

3.3.4 Type of cable lugs shall be as follows:

- Power cables with aluminium conductor : Aluminium crimping type.
- Power cables with copper conductor : Copper crimping type.
- Control Cables : Copper pin type /Copper screw type
- Special cables : pin type / maxi-termi type

3.4.0 Trefoil Cable Clamps

- Clamps required for single core cables carrying alternating current shall be suitable for holding three cables together in delta formation. Clamps shall be of FRP material.
- Clamps shall be of suitable sizes to firmly hold the cables of various outer diameters including tolerance in OD.
- Clamps should have been type tested for Short Circuit Withstand Test .
- For Trefoil clamps run spacing shall be 2000 mm and Axial spacing shall be Double the diameter of larger adjacent trefoils cable or 150 mm whichever is less. Supports shall also be provided at each bend

3.5.0 Omega Cable clamps

- Omega clamps shall be of galvanized mild steel and shall be used to fasten the individual multi-core cables.
- Clamps shall be of simple construction, made of 2mm thick, 25mm wide strip of omega shape and suitable for clamping on the rungs / perforated sheet of tray with the help of two bolts.
- Clamps shall be of different sizes for different outer diameters of cables. Omega cable clamps shall be used for individual cables above 35mm outer diameter.
- Steel clamps shall be hot dip galvanized. Weight of zinc not less than 610 gms. per sq. metre
- For cables of above 35 mm OD, cables shall be individually clamped at 5000 mm interval for Horizontal runs and shall be individually clamped at 1000 mm interval for Vertical runs. Supports shall also be provided at each bend.



- For cables of up to 35 mm OD, cables shall be collectively clamped at 5000 mm interval for Horizontal runs and shall be collectively clamped at 1000 mm interval for Vertical runs. Supports shall also be provided at each bend.
- For cables supported along structures/ceiling, clamp spacing shall be 750 mm. Supports shall also be provided at each bend.

3.6.0 Strip Cable Clamps

- Strip clamps shall be of galvanized mild steel and shall be used to fasten the group of multi-core cables up to 35mm diameter only on a full or part of the tray width.
- Clamps shall be of simple construction, made of 3mm thick Steel, 25mm wide strip to cover the entire width up to 300mm wide tray and part of the tray for more than 300mm wide trays. Strip shall have two right angle bends at each end for fixing on to the rung/ perforated sheet of tray with the help of two bolts.
- Clamps shall be of different sizes for different sizes of tray width. However, the maximum size of clamp shall be 300mm and for cable trays of greater width, two clamps shall be used.
- Clamps shall be hot dip galvanized. Weight of zinc not less than 610 gms. per sq. metre

3.7.0 Self-locking Clamps

- Clamps shall be of FRP material. Clamps shall have self-locking feature when the cord is looped. Clamps shall be provided with manual lock release.
- Clamp cord shall not move in the backward position once it has been locked, unless the lock release is applied.
- Type test certificates to ascertain the strength of clamps shall be submitted for Owner's approval.
- Not more than four (4) cables shall be clamped together, wherever collective clamping is permitted.
- Clamp length shall be selected such that not more than 80% of lockable length is utilized for clamping.
- Nylon self-locking tie strips for collective clamping (up to 35mm OD max. group of 4 cables) shall be 4 mm having Tensile strength 30 kg.
- Nylon self-locking tie strips for Individual multicore clamping (above 35mm OD up to 55mm OD) shall be 4 mm having Tensile strength 20 kg.
- Nylon self-locking tie strips for Individual multicore clamping (above 55mm OD) shall be 7 mm having Tensile strength 60 kg.

3.8.0 Tags

- Cables shall be provided with cable number tags for identification.
- Cable tags shall be of aluminium.
- Cable numbers shall be engraved type
- Tags shall be of durable quality of size 60mm x 12mm with a tie hole at each end.
- Samples of tags shall be approved by the Owner before delivery.
- Tags shall be provided with non-corrosive wire of sufficient strength for tagging.

3.9.0 Junction Boxes

- 3.9.1 Junction box with IP 55 degree of protection, shall comprise of a case with hinged door constructed from FRP material. The junction box shall be provided with canopy. The boxes shall include brackets, bolts, nuts, screws, glands, lugs, M8 earthing stud etc.



- 3.9.2 Terminal blocks shall be of 650V grade, rated for 10A and in one piece moulding. It shall be complete with insulating barriers, clip-on-type terminal numbering on wiring diagrams. Terminal block shall be suitable for terminating 2Cx2.5mm² cable on both sides and arranged to facilitate easy termination. Cable entry shall be from bottom.
- 3.9.3 The boxes shall have provision for wall, column, pole or structure mounting and shall be provided with cable / conduit entry knockouts and terminals.

The list of approved make of the LT Motors are as mentioned below:

S. NO.	LIST OF MOTORS	
1	NON FLAME PROOF	ABB
2		BHARAT BIJLEE LTD.
3		CROMPTON GREAVES
4		GE-POWER
5		KIRLOSKAR ELECTRIC CO LTD.
6		LAXMI HYDRAULICS PVT. LTD
7		MARATHON
8		NGEF
9		RAJINDRA ELECT INDUSTRIES
10		SIEMENS
11	FLAME PROOF	RAJINDRA ELECT INDUSTRIES

However, the final list of makes for the LT Motors is subjected to BHEL/Customer approval, during contract stage, without any commercial implications.

The list of make of CABLE LUGS & CABLE GLANDS are as mentioned below:	
CABLE LUGS	
1	DOWELLS
2	UNIVERSAL MACHINES LTD.
CABLE GLANDS	
1	ALLIED TRADERS & EXPORTERS
2	ARUP ENGG & FOUNDRY WORKS
3	BALIGA LIGHTING EQPT.PVT.LTD.
4	COMMET BRASS PRODUCTS
5	DOWELLS
6	ELECTROMAC INDUSTRIES
7	INCAB

However, the final list of makes for the CABLE LUGS & CABLE GLANDS are subjected to BHEL/Customer approval, during contract stage, without any commercial implications.



**1x800 MW TANGEDCO NORTH CHENNAI
TPP– (FGD SYSTEM)
HVAC SYSTEM
TECHNICAL SPECIFICATION
(C&I PORTION)**

**SPECIFICATION No: PE-TS-485- (571-13000-
A)-A001 (REV-0)**

SECTION : I

SUB-SECTION : C-4

REV. 00

SECTION: I

**SUB-SECTION: C-4
TECHNICAL SPECIFICATION (C&I PORTION)**

**TECHNICAL SPECIFICATION
(CONTROL AND INSTRUMENTATION)
FOR
HVAC SYSTEM**

				
	FGD FOR NORTH CHENNAI TPP STAGE-III (1 X 800 MW)		DESG	BC
	JOB NO: 485		CHKD	CM
	REV. NO. 00	DATE: 21.07.2022	APPD	SSB

INDEX

S. No.	DESCRIPTION
1	TITLE SHEET
2	INDEX SHEET
3	SPECIFIC C&I TECHNICAL REQUIREMENT
4	GENERAL TECHNICAL REQUIREMENTS
5	LIST OF DELIVERABLES
6	FIELD AND MEASURING INSTRUMENTS
7	PROCESS CONNECTION AND PIPING
8	LOCAL CONTROL PANEL AND DATA SHEET
9	INSTRUMENTATION CABLE, CABLE INTERCONNECTION AND TERMINATION PHILOSOPHY
10	SIGNAL EXCHANGE BETWEEN DRIVES AND DCS
11	QUALITY ASSURANCE/CHECK LIST
12	INSTRUMENT HOOK UP DRAWINGS
13	MANDATORY SPARES
14	SUB VENDOR LIST
15	KKS NUMBERING PHILOSOPHY

GENERAL TECHNICAL REQUIREMENTS



**SPECIFICATION FOR
CONTROL & INSTRUMENTATION FOR AUX
PACKAGES**

SPECIFICATION NO.:	
VOLUME	
SUB SECTION	
REV. NO.	DATE :
SHEET	OF

GENERAL REQUIREMENT

- 1.0 Bidder shall provide complete and independent control & instrumentation system with all accessories, auxiliaries and associated equipments for the safe, efficient and reliable operation of auxiliary systems.

- 2.0 The quantity of instruments for auxiliary system shall be as per tender P & ID wherever provided of the respective system as a minimum, for bidding purpose. However, Bidder shall also include in his proposal all the instruments and devices that are needed for the completeness of the plant auxiliary system/ equipment supplied by the bidder, even if the same is not specifically appearing in the P & ID. During detail engineering if any additional instruments are required for safe & reliable operation of plant, bidder shall supply the same without any price implication.

- 3.0 Measuring instruments/equipment and subsystems offered by the bidder shall be from reputed experienced manufacturers of specified type and range of equipment, whose guaranteed and trouble free operation has been proven. Further all the instruments shall be of proven reliability, accuracy, and acceptable international standards and shall be subject to employer's approval. All instrumentation equipment and accessories under this specification shall be furnished as per technical specification, ranges, makes/ numbers as approved by the employer' during detail engineering.

- 4.0 The necessary root valves, impulse piping, drain cocks, gauge-zeroing cocks, valve manifold and all the other accessories required for mounting/ erection of these local instruments shall be furnished, even if not specifically asked for, on as required basis. The contacts of equipment mounted instruments; sensors, switches etc for external connection including spare contacts shall be wired out to suitably located junction boxes.

- 5.0 The customer specification attached as Specific Technical Requirement will supercede the Data sheets, if there is any mismatch.

SPECIFIC TECHNICAL REQUIREMENTS

- 1.0** Air Conditioning and Ventilation System shall be operated from FGD DCS (FGD DCS is in BHEL's scope) for areas/buildings indicated elsewhere in the specification.
- 2.0** Interface of MCC, field Equipment, Actuators etc. with FGD DCS based control system shall be as per Signal interface between drives and FGD DCS enclosed in specification.
- 3.0** Microprocessor based controls of Air cooled condensing unit (D-X type), PAC (if applicable) etc. shall be provided with local display along with facilities to Soft link & Hardwired interface with FGD DCS and to meet the requirement of all system operations and controls. Soft link communication between Microprocessor (MP) based control panels & FGD DCS shall be redundant Bi-directional via TCP/IP on OPC or MODBUS with RS485 link. Bidder shall include required hardware at MP end.
- 4.0** Time synchronization of MP with FGD DCS is to be carried out. Necessary hardware & software for same at MP end to be provided by Bidder.
- 5.0** Complete C&I system for Air Conditioning and Ventilation System is in bidder's scope of supply. Items not specifically mentioned however required for the completeness of the system shall be supplied by bidder without any commercial implication.
- 6.0** The Contractor shall provide complete Instrumentation for control, monitoring and operation of entire Air Conditioning and Ventilation System. The requirements given are to be read in conjunction with detailed Technical specification enclosed in the specification. Further in case of any discrepancy in the requirement within the same section noted by the bidder in the specification, the same will be brought to the notice of BHEL in the form of pre-bid clarification. In absence of any pre-bid clarification, the more stringent requirement as per interpretation of customer shall prevail without any commercial implication.
- 7.0** The quantity of instruments for the system shall be as per tender P&ID wherever provided of the respective system as a minimum, for bidding purpose. However, Bidder shall also include in his proposal all the instruments and devices that are needed for the completeness of the plant auxiliary system/equipment supplied by the bidder, even if the same is not specifically appearing in the P & ID. During detail engineering if any additional instruments are required for safe & reliable operation of plant, bidder shall supply the same without any price implication.
- 8.0** Bidder to supply all the instruments required for the package along with necessary fittings, accessories and valve manifold etc. for control monitoring

and operation of HVAC system. All instruments shall be provided with durable epoxy coating for housing and all exposed surfaces of the instruments.

- 9.0** Earthing of all I&C equipments, control panels, Instruments, Junction boxes and cable trays including above ground panel / below ground / redundant electronic earthing. Bidder shall note that all electronic earthing shall be redundant.
- 10.0** All the Electronic Transmitter for Pressure, Temperature, Differential Pressure and DP based Flow /Level measurements shall be smart type and shall have 4-20mA DC signal with superimposed digital communication (HART).
- 11.0** All the transmitters/transducers supplied by Bidder shall be rack mounted. The transmitter racks shall be in Bidder's scope of supply.
- 12.0** For all instruments envisaged for seawater applications, they shall be provided with wetted parts of Super duplex SS.
- 13.0** All field mounted push button, selector switch etc. shall be as per IEC or NEMA 4X protection. All limit switches shall be conforming to IEC-60947-5-1.
- 14.0** DPG, DPT & DPS across the filters/strainers shall be provided.
- 15.0** Instrument should be in easy reach of maintenance person, there should be separate platform for unreachable instruments. Easy access should be provided to all the tapping points of instruments used for measurement & control.
- 16.0** Instrument installation and accessories required for the same shall be in Bidder's scope and shall be subject to customer/BHEL's approval during detailed engineering.
- 17.0** All Temperature sensors shall be Duplex type. Temperature transmitter shall be provided for all temperature measurement applications. Bidder to provide temperature transmitter along with compensating cable, JB/Rack & other erection hardware.
- 18.0** Analyser and instrument, which are used for protection, shall be 2 out of 3 and interlock controls shall be 1 out of 2, for monitoring panel single shall be considered.
- 19.0** Use of process actuated switch shall be avoided unless unavoidable.
- 20.0** All switches shall be provided with Double action snap type (DPDT) contacts and shall be equipped with plug in type connections for terminating field wiring.

- 21.0** Switch actuation point shall be field adjustable with a calibration scale to indicate the set point. Switches shall have capacity of 5.0 amps at 240V AC or 0.5 amps at 220V DC. Level switches for general service shall be float type. Float material shall be stainless steel SS316.
- 22.0** All transmitters shall be suitably grouped together and mounted inside (i) Local Instruments Enclosures (LIEs) in case of open areas of the plant and (ii) In Local Instrument Racks (LIRs) in case of covered areas.
- 23.0** All instruments shall be provided with durable epoxy coating for housings and all exposed surfaces of the instruments.
- 24.0** Canopy/Enclosure shall be provided for field instruments like transmitters, switches & flow meters, etc and any other equipment to protect from direct sun light, lightning & rain.
- 25.0** All field instruments enclosure shall be IP65, local panel/cabinet enclosure shall be IP 55, unless otherwise specified.
- 26.0** Every instrument requiring power supply shall be provided with a pair of easily replaceable glasses cartridge fuse of suitable rating. Every instrument shall be provided with a grounding terminal and shall be suitably connected to the panel grounding bus.
- 27.0** All instruments and control elements shall be terminated on JB/LCP in field and both instrument and JB/LCP are in bidder scope. Number of Junction Boxes shall be sufficient and positioned in the field to minimize local cabling (max 12-15 mtrs) and trunk cable.
- 28.0** AHU shall be started either locally or from the main Control room by means of Remote / Manual selection facility.
- 29.0** Local control panel (if applicable) shall be in bidder scope and shall have the provision of command (start/stop) & feedback interface with FGD DCS.
- 30.0** Relative humidity and temperature measurement of all control rooms and all major air-conditioned areas shall made be available in Control system.
- 31.0** VFD panels (if applicable) for drives are in Bidders scope. Typical signal exchange with FGD DCS has been indicated in the specification elsewhere.
- 32.0** Drive control philosophy/signal exchange list attached elsewhere in the specification are Tentative and shall be finalized during detailed engineering.

- 33.0** Bidder to include IO from fire protection system (supplied by others) for closing the dampers in the event of fire, the no of IO & other specifications in this regard shall be finalized during detail engineering.
- 34.0** Bidder to furnish electrical load/UPS load data during detailed Engineering.
- 35.0** 415V AC/ 230V UPS Power supply shall be provided by BHEL at a single point, further distribution to various instruments/equipment of the system shall be in bidder scope. Bidder to include necessary power distribution board, changeover circuit in his scope. Any power supply other than the above, if required by any instrument/equipment has to be derived by the bidder from the above supply & all necessary hardware for the same shall be in bidder scope. Bidder to submit the power requirement along with the bid.
- 36.0** Power supply derived for contact interrogation, interposing relay and solenoid shall generally be ungrounded 24 V D.C. only.
- 37.0** The specifications for instruments mentioned in the specification are minimum requirements. The detail specifications shall be finalized during detail engineering. The bidders shall specifically mention any deviation they would like to take on the C&I specification. In absence of only deviation, a No deviation certificate is to be furnished.
- 38.0** The make of the items shall be from sub-vendor list. However, the make/model of various instruments/items/systems shall be subject to approval of owner/purchaser during detailed engineering stage. No commercial implication in this regard shall be acceptable. In case of any conflict or repetition of clauses in the specification, the more stringent requirements among them are to be complied with.
- 39.0** The design, manufacture, inspection, testing, site calibration and installation of all C&I equipment and systems covered under this specification shall conform to the latest editions of applicable codes and standards.
- 40.0** Bidder to perform tests of C&I items/instruments/systems as per Quality plans/type test attached in the specification. However, if any test not specified in the quality plan but specified in Tests for I&C equipment included elsewhere in specification will have to be performed by Bidder without any cost implication.
- 41.0** The scope of cable shall be referred in Electrical scope split sheet in Electrical portion of the specification.
- 42.0** Contractor shall furnish Instrument Schedule, I/O list, Drive list, Cable Schedule, Cable interconnection (DCS end terminal details shall be provided to vendor during detail engineering to incorporate in cable interconnection), JB

grouping, Annunciation list, SOE list, List of Instruments/devices for in BHEL approved format. Also reusable database format like MS Excel, MS Access etc. of these documents shall also be provided by Contractor in BHEL approved format. Soft copy of the formats shall be provided to the successful bidder.

- 43.0** Bidder to provide erection hardware including junction boxes, canopies, structural steel as required.
- 44.0** Every panel-mounted instrument, requiring power supply, shall be provided with a pair of easily replaceable glass cartridge fuses of suitable rating. Every instrument shall be provided with a grounding terminal and shall be suitably connected to the panel grounding bus.
- 45.0** Provision for separate Terminal block/wiring diagram for power and control blocks of control panel to be ensured.
- 46.0** To ensure availability, adequate redundancy in system design shall be provided at hardware, software and sensor level. For the protection system, independent sensing device shall be provided to ensure adequate safety of plant equipment.
- 47.0** Redundancy of sensors shall be provided by bidder (i) Triple redundancy for all analog and binary inputs required for protection of system/drives. (ii) For Interlock purpose dual redundancy of the sensors shall be provided by the bidders.
- 48.0** All panels, cabinets shall be provided with a continuous bare copper ground bus. The ground bus shall be bolted to the panel structure on bottom on both sides. The bolts shall face inside of panels. The system ground shall be isolated from the panel ground with suitable isolators. All internal component grounds or common shall be connected to the system ground, which shall be fabricated of copper flat (size 25mm x 6mm min., length as applicable).
- 49.0** The requirements given are to be read in conjunction with detailed Technical specification enclosed.
- 50.0** The bidders shall specifically mention any deviation they would like to take on the C&I specification. In absence of only deviation, a "No deviation" certificate is to be furnished.
- 51.0** All the instruments/equipments/electrical items shall be provided & designed with maximum star rating as available in line with energy conservation policies notified by BEE, GOI at the time of supply.

- 52.0** All field instruments shall be weatherproof, drip tight, dust tight and splash proof suitable for use under outdoor ambient conditions prevalent in the subject plant. All field-mounted instruments shall be mounted in suitable locations where maximum accessibility for maintenance is achieved. All the field instruments shall also be provided with SS tag nameplate and double compression type Nickel plated brass cable gland. Gaskets, Fasteners, Counter and mating flange (SS316 material), nuts & bolts etc. shall also be included, wherever required with the field instruments.
- 53.0** For instruments which are not located inside covered building, suitable canopy/ protective arrangement shall be provided which shall be approved during detail engineering.
- 54.0** All the wetted parts of the instruments including the accessories like root valves, impulse piping, drain cocks, gauge-zeroing cocks, valve manifolds and all the other accessories required for mounting/erection of these local instruments as well as valves shall be of SS-316 material, suitable pressure class and same shall be in bidder's scope.
- 55.0** All instruments should be supplied with valid calibration and test certificates provided by OEM.
- 56.0** The solenoid-operated valves/Dampers/Gate shall have a limit switch for open/close feedback.
- 57.0** Instrument installation shall be as per the attached "Standard Hook-up diagram of instrument."
- 58.0** At least 20% spare unused terminals shall be provided everywhere including local junction boxes, instrument racks/enclosures, termination/marshalling cabinets, etc.
- 59.0** The contacts of equipment mounted instruments; sensors, switches etc. For external connection including spare contacts shall be wired out to suitably located junction boxes by bidder.
- 60.0** Double root valve shall be provided for all pressure tapings where the design pressure exceeds 40kg/cm² as explained in detailed specification.
- 61.0** All the instruments PG/DPG/DPT/PT etc. (as applicable) having contact with corrosive media shall be provided with chemical/diaphragm seal.

62.0 Bidder's presence is required for 3 Man days (Excluding travel time) at EDN Bangalore during FAT of FGD DCS for certifying correctness & completeness of implementation of Control logic. Intimation to attained FAT shall be informed in 2 days advance. All the expenses like boarding, lodging and travel, Air fare etc. shall be in bidder's scope.

63.0 Bidder's presence is required for minimum 09 Man days (in three visits, excluding travel time) at site in which each visit shall be of minimum 03 Man days during commissioning of DCS for assistance related to process correctness. All the expenses like boarding, lodging and travel, Air fare etc. shall be in bidder's scope.

64.0 Bidder's representative (process/ C&I owner) shall be present at BHEL-PEM Office for minimum 03 man-days, for preparation of Control scheme and operation and control philosophy of AC and ventilation system. All the expenses like boarding, lodging and travel, Air fare etc. shall be in bidder's scope.

65.0 Number of pairs to be selected for Screen/ Control cable

(a) F-Type: 2P/4P/8P/12P(Size : 0.5 mm²)

(b) G-Type: 2P/4P/8P/12P(Size : 0.5 mm²)

(c) Core Cable: 3CX2.5sqmm²/ 5CX2.5sqmm²/ 12CX1.5sqmm²

66.0 Bidder to provide mandatory spares as per mandatory spares list. Attached elsewhere in the specification.

67.0 All the equipments shall be suitably protected, coated, covered or boxed and crated to prevent damage or deterioration during transit, handling and storage at Site till the time of erection. While packing all the materials, the limitation from the point of view of the sizes of railway wagons available in India should be taken account of. The Bidder shall be responsible for any loss or damage during transportation, handling and storage due to improper packing. BHEL shall have right to insist for completion of works in shops before despatch of materials for transportation.

68.0 List of Drawings/Documents and data to be furnished by bidder after award of the contract are mentioned under section "List Of Documents/Deliverables". Further, Editable & pdf copy of any other document decided during detailed engineering shall be furnished after award of the contract:

Note: -

1. All equipment items shall be of latest design with proven on track record.
2. The above given scope is indicative & minimum. Any item/ equipment not indicated above however required for the completeness of the system is to

be supplied by bidder without any technical, commercial and delivery implication to BHEL.

3. Documents of C&I System shall be submitted to end user/owner for approval during detail engineering. Changes, if any, shall be accommodated by the bidder without any price/time implication.

LIST OF DELIVERABLES



C&I SPECIFICATION FOR HVAC SYSTEM

SECTION: C
SUB SECTION: C&I

LIST OF DELIVERABLES OF PEM - C&I DEPARTMENT

Sl. No.	DRAWING NO.	DRAWING/DOCUMENT TITLE	CATEGORY
1	PE-V4-4XX-145-I901	CONTROL & OPERATIONAL WRITE-UP FOR THE SYSTEM WITH SET POINTS	A
2	PE-V4-4XX-145-I902	CONTROL SCHEME/LOGIC DIAGRAM (TO BE IMPLEMENTED IN DDCMIS)	A
3	PE-V4-4XX-145-I903	HMI PICTURES/PLANT SCHEMATICS	A
4	PE-V4-4XX-145-I904	INSTRUMENT SCHEDULE WITH SET POINTS	A
5	PE-V4-4XX-145-I905	I/O LIST (ANALOG & BINARY)	A
6	PE-V4-4XX-145-I906	DRIVE LIST/SOLENOID/ACTUATOR VALVE LIST WITH LOCATION DATA	A
7	PE-V4-4XX-145-I907	FIELD JB/LIE/LIR, DRIVES TERMINATIONS	A
8	PE-V4-4XX-145-I908	DATASHEETS FOR INSTRUMENTS, JBs, etc.	A
9	PE-V4-4XX-145-I909	QUALITY PLANS (INSTRUMENTS, VMS, etc.)	A
10	PE-V4-4XX-145-I910	INSTRUMENT HOOK-UP DRAWING	A
11	PE-V4-4XX-145-I911	THERMOWELL SIZING CALCULATION	A
12	PE-V4-4XX-145-I913	CABLE SCHEDULE & INTERCONNECTION	A
13	PE-V4-4XX-145-I914	ANNUNCIATION & SOE LIST	A

NOTES:

ANY OTHER DOCUMENT DECIDED DURING DETAILED ENGINEERING SHALL BE PROVIDED BY BIDDER WITHOUT ANY COMMERCIAL/TECHNICAL IMPLICATION.

CONTRACTOR TO SUBMIT REUSABLE DATABASE FORMATS IN BHEL/CUSTOMER APPROVED FORMATS LIKE MS EXCEL, MS ACCESS OF DOCUMENTS LIKE INSTRUMENT SCHEDULE, I/O LIST, DRIVE LIST, FIELD JB TERMINATIONS, CABLE SCHEDULE & INTERCONNECTION, etc. SOFT COPY OF FORMATS SHALL BE PROVIDED TO SUCCESSFUL BIDDERS.

FIELD AND MEASURING INSTRUMENTS



- 10.2.5 Thermowells, sight-flow indicators, level gauges etc. shall be of a reputed make and type and shall be subject to the Owner's approval. The switches should be of type designed for alarm and interlock purposes. Thermometers and pressure gauges with contacts attached to perform these functions will not be acceptable.

Field instruments shall be supplied & offered as per data sheets specified below:

10.3.0 Transmitters, Switches, Gauges and Panel Mounted Instruments

10.3.1 Pressure, Differential Pressure, Level and Flow Transmitters (PT, DPT, LT & FT)

- a. Smart Transmitters of the electronic type shall be furnished.
- b. Transmitters shall be equipped with mounting brackets suitable for a mounting in transmitter enclosures.



- c. In general, Transmitters are envisaged to be grouped at several places as to be decided during detailed engineering stage. For this purpose, suitable enclosures complete with all tubing, fittings, purge meters, loop cable trays etc. shall be provided.

Type/Construction : Sealed capacitance/ Inductance/ Silicon resonance type

Material

Body : SS316 T

Diaphragm : 316 SS

Measurement element : Teflon seal

Valves : Carbon steel for non-corrosive Applications
SS316 for corrosive applications, SS super duplex for sea water application.

Output signal : 4 to 20 mA Amp. DC (Two wires)
HART Compatible

Local Indicator : LCD indicator (5 digit) with scale of Engg. Unit

Overall Accuracy : $\pm 0.065\%$ or better of FSR

Turn down ratio : 10:1 for vacuum / very low pressure application
30:1 for other applications

Stability : $\pm 0.15\%$ for 10 years.

Response time : 100 msec.

Power supply : 24V DC nominal

Drive capability : 500 Ohms minimum

Enclosure Class : IP-65 (Explosion proof as per NEC article 500 for hazardous area)

Span and Zero : Locally adjustable, non-interacting

Zero suppression / elevation: At least 100% of Span

Connection

Process : Half (1/2) inch NPT (F)
:

Electrical : Plug and socket, unused entry with blind plug.

Accessories : Span and zero adjustment facility

For Absolute Pressure Transmitters : Two (2) valve SS316 manifold

For Gauge & Vacuum pressure transmitter : Three (3) valve SS316 manifold



- For DP, level & flow Transmitter : Five (5) valve SS316 manifold
- For oil and corrosive liquids : Separator diaphragm seals
- Diaphragm material : SS super duplex
- Flush ring & drain : Provided for lime stone slurry based & sea water applications
- For all transmitters : Mounting bracket
- Mounting : Local (in LIE/LIR)
- d. In case it becomes necessary to use a DP transmitter for pressure measurement, then a 3-Valve manifold shall be used in place of 2-valve manifold. Manifold shall not be mounted on the transmitter; It shall be non-integral type. Pulsation dampeners shall be used where the process media is unstable for measurement such as the discharge of a pump. Overrange protection shall be used where necessary. The coil siphons & condensate pots shall be used for steam services. Transmitters shall be provided with suitable drain & vent points.
- e. As for the water flow/ steam flow measurements, necessary flow elements/transmitters are chosen in the process line and supplied such that their algebraic summation shall be mass balanced for calculating the system efficiency.
- f. Contacts less, electronic 2-wire position transmitters shall be provided for all inching type motorized valve and dampers.
- g. For acid and alkali applications, only non-contact type level transmitters like acoustic, ultrasonic, radar based shall be provided by bidders.
- h. Where the process fluids are corrosive, viscous, solid bearing or slurry type, diaphragm seals shall be provided. Parts below the diaphragm shall be removable for cleaning. The entire volume above the diaphragm shall be completely filled with an inert liquid suitable for the application. For hazardous area, explosions proof enclosure as described in NEC article 500 shall be provided.
- i. LVDT type is not acceptable.
- j. Transmitters & other HART based instruments shall be supplied along with 3 Nos. of universal type hand held/portable pressure calibrators. Temperature transmitters shall be supplied along with 3 Nos. of hand held/portable mV source generators.

10.3.2 Pressure Switches (PS) & Differential Pressure Switches (DPS)

- Applicable Standards : IS3624 – 1966/ISA-RP-8.1 except as modified in spec.
- Type/Construction : Bellows /Sealed Diaphragm for low pressure / vacuum and Piston Actuated preferable for high pressure. Indicators with contacts are not acceptable.

Materials-

- Bellows : 316 SS
- Bourdon tube : 316 SS
- Movement : 316 SS



Protective Diaphragm	:	Die-cast aluminum with stoved enamel black finish. Epoxy coating shall be provided for corrosive atmosphere.
Accuracy	:	± One (1) percent or better
Repeatability	:	± 0.5(half) percent or better
Setting & Differential	:	Adjustable
Over pressure range	:	Fifty(50) percent of full scale.
Contact	:	
Number	:	DPDT /2 SPDT
Type	:	Auto reset with internal Adjustable snap action micro switch
Rating	:	5 Amp, 240V AC / 0.5 Amp, 220V DC
Connection – instrument Electrical	:	Half (1/2) inch NPT male Process Suitable for Plug & socket connection. All the switches are internally connected and brought to the surface with amphenol male/female connection. Cabling need not terminated inside the switch. Cable ends are to be soldered in connector and to be inserted for easy maintenance.
Over range protection	:	Fifty (50) percent of full scale
Enclosure	:	IP 65
Accessories		
3 / 5 valve manifold	:	For all switches
Self-cleaning type Pulsation dampeners/Snubber (Material SS316)	:	Pump and compressor discharge lines
Syphon	:	For all steam lines
Diaphragm material	:	SS super duplex
Flush ring & drain	:	Provided for lime stone slurry based & sea water applications
Protective separating diaphragm Mounting	:	For Corrosive liquid lines. Local (in LIE/LIR)

10.3.3 Pressure & Differential Pressure Gauges (PG & DPG)

Applicable standard	:	IS: 3602-1966, IS/3624, ASME B 40.1
Sensing Element and Materials	:	Bourdon for high pressure, diaphragm/bellow for low pressure of all materials in SS 316



Case	:	SS 316/ Die-cast aluminum with stoved enamel black finish. Epoxy coating shall be provided for corrosive atmosphere.
Protective Diaphragm	:	Teflon
Dial size	:	150mm with shatter proof glass
Scale Details	:	Graduations in black lines on white dial, 270 Deg pointer deflection scale provided with glass cover. Smallest scale division shall be one (1) percent of full scale value or smaller. Pointer stop for all gauges.
Accuracy	:	± One (1) percent or better
Connection – Instrument Process	:	1/2 inch NPT Male Bottom
Mounting	:	Local : 1/2 inch NPT Male (Back entry) mounted on local gauge board.
Accessories		
3 way needle valve/manifolds	:	For all gauges
Self-cleaning type Pulsation dampener/snubber	:	Pump and compressor discharge lines
Syphon	:	For all steam lines
Protective separating	:	For fuel oil and corrosive liquid lines
Other particulars		
Zero & span adjustment Safety device	:	For all gauges
Housing	:	IP 65
Diaphragm material	:	SS super duplex
Flush ring & drain	:	Provided for lime stone slurry based & sea water applications
Ranges 5 to 20 Kg/cm ²	:	Rubber blow out disc with open front construction
Ranges above 20 Kg/cm ²	:	Neoprene safety diaphragm at the back with solid front construction
Over range protection	:	Fifty (50) percent of full scale : Movement mechanism shall be glycerin filled for oil services & vibration prone area. : For corrosive liquid lines diaphragm type sensors required. Armored capillary of 10 mtrs for Corrosive liquid service



: Contact type pressure gauges are not acceptable for interlock & protection.

Identification : Identification engraved with service legend or laminated phenolic name plate.

10.3.4 Resistance Temperature Sensors with thermowells

Applicable Standard : ASME PTC 19.3 / DIN 43760 for RTD -Latest Revision

Element : Platinum, R0=100 ohm 4 –wire Duplex

Sheath Material/ Insulation : 316SS metal sheathed /Compacted Magnesium Oxide

Sheath OD : 8 MM

Terminals : Spring loaded

Calibration : As per DIN Standard – 43760, Class A

Head : Die Cast Aluminum (Screwed) with galvanized chain

Response Time : < 20 Sec for measurement
< 10 Sec for Control

Accuracy : $\pm 0.35^{\circ}$ C or class A DIN 43760 whichever is better.

Electrical connection : Plug in connector type

Enclosure : IP 65

Thermo well

Applicable Standard : ASME PTC 19.3 TW – 2010

Construction : Tapered drilled from Bar stock for SS316 material thermowell. (Straight for Air & Gas systems)

Material : - 316 SS – water and steam services
SS Duplex for sea water based application
- Inconel for air & flue gas services

Bidder shall provide calculation for thermo well as per ASME – PTC-19.3.

Process Connection : i) M33 x 2
ii) Flanged for Air & Gas systems with mating flanges

Immersion Length : Within ± 10 mm of center line of pipe

Extension neck length : Minimum 100 mm above Insulation of pipe and Minimum 160 mm when there is no insulation on pipe.



IBR Certification : For high pressure service, Steam Temp.,
Fuel oil temp. Measurement as per IBR
rules and regulations

Note :

Extension/Compensating cable exposed to atmosphere in the conventional method melts away in the high temperature. Hence The terminals of temperature sensors shall not be at the high temperature zone. The temperature sensors wires are to be laid up to JB through SS tube of required diameter and the head shall be placed nearer to the JB.

1



10.3.7 Temperature Gauges (TG)

Applicable standard	:	IS : 3602,BS:5235 ISA:RP:8.1 except as modified in this specification
Type/Construction		
- Thermometer	:	Industrial type, Inert gas type
- Thermowell	:	Bar stock
Material		
- Thermowell & Bulb	:	316 SS SS Duplex for Sea Water based application
-Movement	:	316 SS
- Capillary	:	Armoured SS (Applicable for capillary Type)
- Casing	:	SS 316/ Die-cast aluminum with stoved enamel black finish. Epoxy coating shall be provided for corrosive atmosphere
Dial Size	:	150mm with shatter proof glass
Scale Details	:	270 degree dial rotation/deflection. Graduations in black lines on white dial provided with glass cover. Smallest scale division shall be one (1) percent of full scale value or smaller. Pointer stop for all gauges
Accuracy	:	± One (1) percent or better
Response time	:	Maximum 15 seconds without thermowell
Connection		
- Pipe	:	M33 x 2
- Thermowell	:	To suit instrument
Other Particulars		
- Capillary length	:	5Meters/10 Meters as required
- Immersion Length	:	Within ± ten (10) mm of center line of pipe with adjustable nuts.
- Extension neck length	:	Minimum 50 mm above insulation of pipe /As per approved hookup drawings.
- Stop at Maximum value	:	For all gauges of scale



- Pointer	:	Externally adjustable Contact type Temp. gauges are not acceptable for interlock & protection.
IBR Certification	:	For high pressure service, Steam Temp., Fuel oil temp. measurement as per IBR rules and regulations
Enclosure protection	:	IP 65

10.3.9 Temperature Transmitters (TT) ((pg:78 cl:10.3.1)

Type	:	SMART type configurable from control room through HART protocol (HMS System).
Display type	:	Indicating type (5 digit LCD Display),
Accuracy	:	±0.10%

10.3.10 Ultrasonic Level Transmitter (for Water sump/Tank level measurement)

Type	:	Non-contact Microprocessor based 2 wire type, HART protocol compatible
Principle of Operation	:	Detection of reflected ultrasonic pulse
Measuring Ranges	:	Up to 30 meters (typical)
Signal Processing	:	Microprocessor Controlled Signal Processing
Operating Freq.	:	10 KHz to 50 KHz (typical)



Display	:	Head mounted Large alpha-numeric back lit LCD/LED
Calibration & Configuration	:	Accessible from front of panel
Diagnosis	:	On-line
Status	:	For power, Hi / Lo / V. Hi / V. Lo-level indication, fault etc.
Construction	:	Plug-on board
Power supply	:	24 V DC +/- 10% or 230 VAC 50 Hz
Signal Output	:	Galvanically isolated 4-20mA DC with HART protocol
Hysteresis	:	Fully adjustable preferred
False signal tolerance	:	Transmitter shall be capable of ignoring false echoes
Output contacts	:	2SPDT Potential free changeover contacts @ 8A 230V AC.
Accuracy & Repeatability	:	±0.25% of span or better
Temperature compensation	:	To be provided with transducer
Resolution	:	±0.1% of span
Operating temp.	:	Transmitter-50 deg C and Sensor –80 deg C
MOC Sensor	:	Body- PVDF and Face – Polyurethane or Corrosion resistant material to suit Individual application requirement
Humidity	:	1% to 95% non-condensing.
Enclosure	:	IP-65 Epoxy painted die cast Aluminum or SS316L housing.
Cable Connection	:	Plug and socket.
Mounting	:	2" – 4" NPT or flanged
Accessories	:	Cable gland, prefab cable, mounting accessories like EPDM seal, SS316 flanged etc.

Additional separate local display unit with large Alphanumeric back light LCD/LED & to be provided for the applications which will be decided during detailed engineering.

All weather canopy for protection from direct sunlight and direct rain.



All mounting hardware and accessories required for erection and commissioning mounting fittings material shall be SS 316.



10.3.15 Level Switches (LS)

- Type/Construction : a) External float cage type with magnetic switch actuator for tanks and vessels.
- b) Displacer –Top mounted for all clean water sumps.
- c) Conductivity type for high Pressure and high temperature enclosed vessel like drain pot, HP heaters etc.
- Materials
- Body : Cast Carbon Steel suitable for specified pressure and temperature ratings
- : For corrosive liquids suitable anti-corrosive coat/lining shall be provided.
- Float/Displacer : 316 SS
- Wire rope : 316 SS
- Differential & Setting : ± 12 mm minimum (Adjustable) Contacts
- Number : DPDT/2 SPDT



- Type : Snap action micro switch Auto reset with internal Adjustable
- Rating : 5 Amp 240V AC, 0.5 Amp 220V DC
- Connection – Process : One (1) inch Scrd NPT Female
One (1) inch ANSI Flanged
Four(4) inch ANSI Flange for sump services.
- Electrical : Suitable for Plug in type. All the switches are internally connected and brought to the surface with Amphenol male/female connection. Cabling need not terminated inside the switch. Cable ends are to be soldered in connector and to be inserted for easy maintenance.
- Enclosure protection : IP 65
- Temperature/pressure rating: As per service conditions
- Accessories : Counter flanges, still pipe of requisite length with anticorrosive coating for sump services.

I
f



Accessories : Counter flange, Cable gland, prefab cable and stainless steel name plate engraved with alpha-numeric.

→ Accessories (to be same open to atmosphere only),

HUMIDITY SENSOR

Sensor : Capacitance type
Accuracy : +/-3% R.H
Range : 0-100% R.H
Output : 4-20 ma
Time constant : 2 mins.

Output from the sensor is to be connected to respective control system. Contractor can also provide combined instrument for measurement of humidity and temperature subject to Employer's approval during detailed engineering. In all such cases, 4-20 ma outputs, each for temperature and humidity measurements are to be provided.

TEMPERATURE / HUMIDITY INDICATOR

Sensor : RTD for(Pt 100) for temperature
: Capacitance Type for Humidity (specs for humidity and temperature shall be as mentioned above)
Display : Combined enclosure with two three digit seven segments LED display with decimal point after two digits. LED height shall be 4 inches, clearly legible from a distance of at least 10 meters.
Range : 0-60 Deg C for temperature.
: 0-95.0 % for Relative Humidity.
Accuracy : Better than +/- 0.5 % for Temperature
: Better than +/- 2.5 % for Relative Humidity
Mounting : Table Top/ wall mounting.
Power supply : 240 V AC, 50 Hz.
Output : 4-20 mA signal each for temperature.

One Set of output signal is to be connected to respective control system. Apart from displaying the temperature/humidity values on indicator.



10.3.30 **Junction Boxes**

Bidder shall note that the Analog and digital signals shall be wired to different junction boxes.

- | | | |
|-------|--|--|
| (i) | No. of ways | 12/24/36/48/64/72/96/128 with 20% spare terminals. |
| (ii) | Material | 4mm thick fibre glass reinforced polyester. |
| (iii) | Type | Screwed at all four corners for door. Door handle shall be self-locking with common key. Door gasket shall be of synthetic rubber. |
| (iv) | Mounting clamps and structures etc accessories | Suitable for mounting on walls, columns,.

The brackets, bolts, nuts, screws, double compression glands and lugs required for erection shall be of brass, included in Bidders scope of supply. Race ways for routing of cables inside JBs shall be provided. |
| (v) | Type of TB | Rail mounted maxi termi or cage-clamp type suitable for terminal conductor size upto 2.5 mm ² . A M6 earthing stud shall be blocks provided. |
| (vi) | Protection class | IP:65 minimum and Explosion/Flame Proof as per area classification. |

10.3.31 **Interposing Relays (IPR)**

Electromagnetic type IPRs with modular design, plug-in type connections, suitable for channel/DIN rail mounting in cabinets; coil rating 24V D.C; 2 set of change over contacts rated for 0.5A 220 V DC / 5A 240 V AC. Freewheeling diode across relay coil and self-reset type status LED indicator flag (electronic) shall be provided. Manual forcing/override facility is required. The test voltage for relay shall not be less than 4 KV with operating temperature from -20 deg. C to 60 deg. C. The relay shall have the necessary approvals like V0 inflammability class in accordance with UL94", IEC60664/ IEC60664A/DIN VDE 0110.



- 10.3.32 **Digital Indicator**
- Type : Programmable electronic digital indicator with floating point decimal.
- Input : 4-20 mA DC/1-5V DC/RTD/T/C.
- Number of inputs : One
- Range : As per requirement/adjustable by end user through key pad available on the indicator.
- Number of digits : Four plus sign
- Digit height : 20 mm or larger
- Display : Fluorescent red
- Input over range/open : All digits to flash sensor (T/C)
Input hold time : 0.7 seconds max.
- Accuracy : $\pm 0.05\%$ of span
- Power supply : 240V AC, 50Hz
- Mounting : Flush panel, compatible for mounting on mosaic grid panel
- Size : 96x48 mm
- Other Particular : Indicator receiving thermocouple Signal shall have automatic cold junction compensation.
Retransmission Output 4-20 mA isolated required.
: 24 V DC inbuilt power supply
: Alarm contact with 2 NO/NC contact (rating 5A/230 V AC)
- 10.3.33 **Receiver Indicators (Single/Dual Channel)**
- Type : Analogue indicator
- Input Signal : Universal input (T/C, RTD, 4-20 mA, Voltage)
- Scale : Range fully configurable and programmable
- Measurement Accuracy : $\pm 0.2\%$ of span + 1 count
- Resolution : 0.5% Span
- Dead band : $\pm 0.2\%$ of span
- Repeatability : 0.2% of span
- Full scale response time : Less than two (2)seconds
- Power Supply : 240V AC, 50 Hz



	Connection	:	Plug in type
	Accessories	:	Mounting Bracket for Bins
	Other Particulars	:	Indicator receiving thermocouple Signal shall have automatic cold Junction compensation.
		:	Retransmission Output 4-20 mA Isolated required.
10.3.34	Ammeters (AMM)		
	Input	:	4-20 mA DC
	Mounting	:	Flush panel, compatible for mounting on mosaic grid panel
	Face Dimensions	:	96 x 96 mm
	Scale/Type	:	Moving coil, circular, FSD 240
	Zero adjustment	:	Screw on meter face
	Accuracy	:	± 1 percent (class 1)
	Indication	:	Pointer with scale
	Magnetic Shield	:	Shielded Case
	Quantities	:	For all HT Motors & LT motor with rating \geq 30 KW and other critical application motors/drives.
10.3.35	Voltmeter		
	Input	:	4 – 20 mA DC
	Mounting	:	Flush Panel, compatible for mounting on mosaic grid panel
	Face Dimension	:	96x96 mm
	Range	:	As per requirement
	Accuracy	:	$\pm < 0.5$ %
	Indication	:	Digital type 4 1/2 digit
	Magnetic Shield	:	Shielded Case
	Connection	:	Plug in type
	Quantities	:	For 240 V AC input power supply, UPS power supply, 24V DC interrogation voltage & 220 V DC.



- 10.3.36 **Push Buttons (PB)/ ILPBs for On/Off, Open/Close**
- Type : Momentary / Miniaturised suitable for mosaic grid 24x48 Mm with 2 PB and 3 coloured LED.
- Contact Configuration : 2 NO + 2 NC
- Contact Material : Hard Silver Alloy
- Contact Rating : 500V / 10 A
- Insulation Voltage : 2 KV for 1 minute between terminals and earth
- Lamp Rating : a) Voltage : 240 V AC
b) Watt : 2 Watt (approx.)
- Colour : Red, Green, Amber, Yellow
- 10.3.37 **Push Button For Desk Release,**
- Push button for desk release : Momentary mosaic grid mounted
Desk lamp test desk ack : 24x48 mm size, single PB 18x40 mm
- 10.3.38 **Push Button for Sequence Start/Release**
- Push Button for Sequence Start/Release : Momentary (Miniaturised) suitable for mosaic grid 24x48 mm 3 PB + 5 LED
- 10.3.39 **Push Button for Annunciation**
- Contacts
- Number & Type : As per requirement
- Breaking capacity : 0.5 Amp, 220V DC
10 Amp, 600V AC Different colours for Accept/Ack – Green, reset Grey, test – Yellow & Audio Ack – Black.

PROCESS CONNECTION AND PIPING



12.0.0 ERECTION HARDWARE

12.1.0 General Requirements

12.1.1 This section covers the material requirement for instrument connection to process, instrument process, piping, tubing, supports, transmitter racks and main accessories to be furnished under this specification and the requirements of installation and routing. Impulse lines, fittings and other accessories required for the erection of complete Instrumentation and Control System supplied under various packages of this specification shall be supplied on "as required" basis. Bidder shall offer all necessary items for this section based on his experience on similar plants, plant layout diagrams, installation drawings and other applicable sections of this specification. Based on the good engineering practices, Bidder shall furnish installation drawings during the engineering of the system for Owner's review and approval. The installation of the drawings shall be suitable for his installation of his range of instrumentation.

12.1.2 The Bidder shall furnish and test all required erection hardware, which is necessary for proper installation and interconnection of the equipment/systems furnished by the Bidder and their integration with main equipment/systems as per the enclosed installation drawings and other applicable clause. The Bidder shall furnish all hardware and accessories to ensure that the equipment/systems furnished form a complete and operational system meeting the intent and requirement of this specification.

12.1.3 All materials, furnished shall conform to the latest editions of America National Standard Code for Pressure piping, Power piping, ANSI B311.1, ANSI B16.11, ASME Boiler and Pressure Vessel Codes, IBR and other applicable ASME, ANSI and Indian Standards. Schedule numbers, sizes and dimensions of all carbon steel, stainless steel and alloy seamless steel pipe shall confirm to ANSI B.36.10 and of stainless steel pipe shall confirm to ANSI B 36.19 unless otherwise specified.

12.1.4 Instrument erection hardware which includes all junction boxes, cable trays, cable glands, lugs, cable ties, support, local panels, pneumatic and process hook up hardware, Impulse piping & fittings and other erection materials and accessories required for the system supplied.

12.1.5 All materials supplied under this section shall be suitable for intended service; process operating conditions and type of instruments used and shall fully conform to the requirements of this specification.

12.1.6 The Bidder is responsible for the performance of the equipment furnished on system basis any shortfall in erection material observed during erection stage shall be compensated by the Bidder at no extra cost.

12.2.0 Process Connections

The type of instrument source connection shall depend upon the process parameters and the tapping size. The source connection drawings shall be finalized during the engineering stage, Refer Hookup diagram.

12.3.0 Impulse Piping System

General

Impulse piping system consists of primary impulse pipes/tubes, valves, fittings, valve manifolds and other accessories between the source connection point (source shut-off valve onwards) and all instruments/devices. Impulse pipe span for supporting clamp shall be 1.5 mtr. This will also include all piping and valves etc. required for instrument drain and vent connections. The Bidder shall furnish and test all items required for completeness of this specification.



12.5.0 Process Connections

Following type of source connections shall be provided by the Bidder on equipment/piping for instrumentation purpose.

1. Source valves for pressure and differential pressure measurements as per enclosed instruments source connection details.
2. Threaded/weld able stubs for thermowells of various sizes for temperature elements as per enclosed source connection details.



3. Source valves with socket welded connections for level services as per enclosed instrument source connection details.
4. For control actuators at the master operating spindles/levers of the final control elements.

However, if the source connection details, as illustrated, do not match with the connection ports of the instruments, the same may be altered in consultation with Owner.

12.6.0 Impulse Tubing

High pressure and high temperature services (Water)

Seamless Alloy Steel piping to ASTM A335 GR.P22 (schedule 160 for high pressure & high temperature)

Low pressure and Low temperature services(Water)

Seamless carbon steel piping to STM A106 Gr.B

Low pressure and low temperature services (Air)

ERW carbon steel piping to IS 1239: 1973 Heavy class System

Analysis system

Seamless stainless steel piping to ASTM A312 GR. TP-321

12.7.0 Fittings Double compression type

- i) Material for socket weld fittings
- ii) Dimensions of fittings

ASTM A105 ASTM A182, Gr. F22
6000/3000 lbs

ANSI B16.11

12.8.0 Valves

- i) 3-way valves
- ii) 3-valve/5- valve manifolds
- iii) 2-valve manifolds
- iv) Isolation and drain valves

SS body/Forged CS body stellated internals and SW ends as per requirement for 2500 lb/600 lb ASA ratings.

FAS body/FCS body 316SS stellated internals with NPT(F) SCR D ends for 2500 lb/1500 lb/600 lb ASA ratings.

FCS body, 316SS stellated internals, NPT(F) SCR D ends.

Globe valves with FAS

12.9.0 Condensation vessels

body/FCS body, 316SS stellated internals, SW ends for 2500 lb/1500 lb/600 lb ASA ratings.

12.10.0 Flexible conduits with fittings

Lead coated, paper insulated, heat resistant flexible metal conduits with necessary fittings.



12.11.0 Guideline for Installation and Routing Of Instrument Piping

12.11.1 General Requirements

The following general erection guidelines have been enumerated here to enable the Bidder to estimate the requirement of instrument piping in plant:-

1. All instrument piping shall be in accordance with good engineering practice. It shall be finalized during engineering stage. Instrument piping shall be complete with fittings, valves and other required accessories.
2. Instrument piping shall not be routed:-
 - a) Across equipment removal areas
 - b) Below mono-rails and cranes
 - c) Above or below removable gratings
 - d) Above or below cable trays.
3. Primary Impulse Piping System: _
 - a) The primary impulse piping system shall include the instrument piping and all required accessories from process tap off point (root valves onwards) up to the respective instruments. From the same source, Tee off for instruments are not allowed. Separate tapping shall be provided for each instrument. The Bidder shall provide the necessary fittings and accessories along with impulse pipes for completeness and arrangements as per the finalized Instrument Installation Diagrams. Special accessories such as reservoirs and other devices shall be installed as required for flow primary element connection as required by the design of instruments, in accordance with the instructions of the instrument manufacturer.
 - b) The Bidder shall prepare impulse pipe routing drawings.
 - c) Impulse piping shall include a blow-down line and shut-off valve adequate for the duty requirements and for withstanding continuous design pressure and temperature of process medium. For process pressure above 40 Kg/Cm²g, double valves shall be used before connecting to the blow-down header (This arrangement shall be provided for installation for the new transmitter if the existing transmitter has the same arrangement.)
 - a) To assure a constant static head the connections from low pressure steam and low pressure liquid filled lines should preferably slope downward continuously towards the instrument as the instrument is mounted below the source point. If downward slope is not feasible or the instrument is mounted above the source point, the line should slope upward continuously and a "pigtail" installed at the instrument to assure a water seal for temperature protection. Upward sloping liquid lines should be used only if the process pressure is sufficient to assure a head of liquid at the instrument. Horizontal runs should have a slope of not less than 40 mm per meter and must be adequately supported to maintain a constant slope. Vacuum connections to the condenser should always slope upward to the instrument.
4. Primary process piping for steam flow, liquid flow and manometric level measurement systems should preferably slope downward from the primary element connections to the instrument. Primary piping for flue gas and air flow measurement systems should preferably slope upward from the primary element connections to the instrument. If these requirements cannot be met, special venting or drain provisions will be required. Horizontal runs must have a slope of not less than 40 millimeters and must be adequately supported to maintain a constant slope.



5. Primary process piping from the field which enters the instrument enclosure from the bottom shall extend into the enclosure approximately 150 millimeters and be equipped with a socket weld to flare less tubing coupling of stainless steel. This coupling shall be used to connect the field primary process line to the enclosure process line. The field primary process line shall be anchored to the enclosure angle with U-bolts. Holes for supporting U-bolts shall be field or drilled. All impulse piping shall be supported rigidly at an interval not exceeding 1.5 meters so as to prevent excessive sag in piping. Process piping shall not be used for supporting impulse piping.
6. Impulse lines subject to severe sonic pulsations shall be of sufficient length and of suitable configuration to scatter harmful sonic wave energy before it reach the instrument.
7. Impulse piping shall be installed to permit thermal expansion without placing excessive stress on the piping and without affecting the gradient of slope. Long continuous straight runs of piping shall always be avoided. If required, expansion loops shall be provided at least every 2.5 meters to break the continuity.
8. All welded and screwed fittings shall conform to ANSI B16.11. Threads of piping components shall be taper pipe thread in accordance with ANSI B2.1. All threads shall be clean machine cut with all burrs and chips removed. Lubricants shall be of dry filch type. Any one of the following compounds may be used as a pipe thread sealer. Bidder shall supply adequate amount of his preferred sealer for erection purpose. Teflon tape shall not be used as a pipe thread sealer.



12.11.2 Transmitter & Switches Enclosures

In general, process parameter transmitters & switches installed at outdoor location and in areas where they are subjected to splashing oil, water, steam etc., shall be mounted in closed type transmitter rack. For other areas (indoor), open type racks may be used for installation of transmitters and process switches. However the actual requirement shall be finalized during detailed Engineering considering following:-

1. Transmitter/Switches enclosures shall be free standing, enclosed type offering protection against dust, moisture and vermin. Enclosures shall be suitable for outdoor installations, in thermal power plants.
2. The enclosures shall comprise of Galvanized Sheet mounting plate internally. Also external-mounting brackets in Polyamide or Stainless Steel shall be available and shall be weather proof. Panel thickness shall be 3 mm for instrument supporting faces and back and for remaining sides shall be 2 mm.
3. Instrument piping inside the enclosure shall conform to the specification and in line with typical installation drawings enclosed with the specification.
4. Blow down header shall be provided inside the enclosure as called for.
5. Bulk head connection shall be provided to receive and terminate the impulse pipes from root valves.
6. Instrument tubing, fittings and isolation, drain valves shall be to ANSI code for pressure piping. Piping/tubing shall be subject to hydrostatic tests at 1.5 times maximum system pressure.
7. Support angles shall be provided for valve manifolds, wiring trays etc. Enclosures shall be complete with necessary bulk head fittings, junction boxes, drain header and other accessories as needed on the basis of approved hook up drawings.
8. Sufficient spacing among adjacent transmitters shall be maintained to offer easy accessibility and operational convenience. The enclosure shall be designed with sizes to suit the grouping and to completely include all the hardware for hooking up the transmitters to the process on the basis of approved installation diagrams. A maximum of Six (6) transmitters are envisaged to be grouped in one enclosure.
9. The field devices like switch devices, limit switches, position transmitters, solenoid valves etc shall be provided with removable type insert & screw type connectors, or terminal heads suitable for easy maintenance and testing of these equipment items.
10. All spare contacts/terminals on relays, control switches, limit switches or similar devices, process switches, duplex RTDs & Duplex T/Cs shall be wired to accessible terminal blocks/JBs for Owner's future connections. All wiring leaving a junction box or enclosure shall leave from terminal blocks and not from other devices in the enclosure. Two (2) pair cables shall be provided for terminating the transmitter to local JB's.
11. Auxiliary equipment such as relays, terminal blocks etc shall be readily accessible and servicemen shall have direct access to the equipment without removal of barriers, cover plates or wiring.
12. All electrical cables shall be conservatively selected for the electrical and environmental conditions of the installation and shall be of the best construction for the service conditions encountered. Oil resistant and proper temperature applicable cable shall be used throughout.



13. A minimum of twenty (20) percent spare terminals shall be provided. Only one wire per terminal shall be used on the outgoing side of these blocks (for cable panel). Any common connections required shall be provided on the panel side of the block. All incoming power terminals are to be clearly identified in a manner distinctly different from all other terminals and grouped in a logical pattern.
14. Each wire is to be identified at both ends corresponding to wire number shown in wiring diagrams.
15. All wire terminations at terminal, shall be made with compression type connections properly sized for the conductor and the terminal. The connector shall be constructed of fine grade high conductivity copper and shall be tin plated. No more than two wires shall be connected to a terminal. Vertical wiring on the panels between the terminal blocks and the devices shall be enclosed in non-metallic raceways or punched metal raceways with removable cover. Horizontal wiring between the raceways and the devices may run exposed. Wiring on the panels shall be formed neatly with wires neatly grouped in packs using non-metallic bends, and with group substantially supported along the panel.
16. Wire stripping shall be done in such a manner that conductor will not be nicked or cut.
17. The entire arrangement of wiring and arrangement of connections/ terminal blocks shall be acceptable of the Owner's Engineer.
18. Switches for temperatures, flow, level, pressure etc. required for unit protection/interlock shall be triplicated.
19. Each instrument shall be provided with nameplate and labels etc.

12.11.3 Local Instruments, Local Boards and Tapping Points

- i. All local gauges as well as sensors and switches for parameters like pressure, temperature, level, flow etc for safe and efficient operation of equipment under the scope of specification, shall be provided by bidder as approved by Owner. Such equipment shall be listed by the Bidder detailing the items with the respective functions in service. All field mounted instruments shall be mounted in such a way as not to be affected by vibration & environmental conditions. Racks to mount these instruments shall be furnished by bidder complete with requisite erection hardware, tubings and junction boxes with all terminals of the instruments duly wired complete with cable glands. Groupings of instruments, actual number of racks for instruments and its construction shall be to Owners approval.
- ii. Transmitters provided shall be mounted in transmitter enclosures to Owner's approval. The junction box for electrical connections shall be outside the transmitter enclosures.
- iii. All erection hardware required for complete installation/ implementation of entire instrumentation specified is included in bidders scope. Any change in size, type, and rating or in quantity deemed necessary during engineering shall be supplied within package price with no additional financial implication to Owner.
- iv. Bidder's scope includes providing counter flanges on pipe lines/ vessels to suit Owner arranged flanged devices. Counter flanges shall be complete with gaskets, nuts, bolts and other requisite accessories for proper installation.
- v. Separate and independent tapping on equipment/associated piping shall be provided to suit the philosophy of redundant primary sensors. Separate sensors for control and monitoring etc are as decided by Owner. This shall include application such as first stage pressure. Wherever the process value being measured needs to be



compensated for temp, pressure variations, the tapping points for such compensating elements shall be provided in requisite number along with the tapping for the process value.

- vi. Tapping points shall include probes, wherever applicable, for analytical measurements and sampling.
- vii. For direct temperature measurement of all working media, one stub with internal threading of approved pattern shall be provided along with suitable plug and washer. The Bidder will be intimated about thread standard to be adopted.
- viii. The following shall be provided on equipment by the Bidder. The standard which is to be adopted, will be intimated to the Bidder.
 - 1. Temperature test pockets with stub and thermowell
 - 2. Pressure test pockets

12.11.4 Size of tapping point stub, number and size of root valves for different types of measurements

Size of tapping point stub, number and size of root valves for different types of measurements are as follows:

Sl. No.	Quantity of root valves	Size of stub and root valve	Service Condition
Pressure and Differential Pressure Measurement			
(i)	2	25NB	> 40 bar(g) OR 425degC
(ii)	1	15NB	< 40 bar(g) AND 425degC
Level Measurement			
Level Gauge & Switch			
(i)	2	25NB	> 40 bar(g) OR 425degC
(ii)	1	25NB	< 40 bar(g) AND 425degC
Level transmitter (displacement type)			
(i)	2	40NB	>40 bar(g) OR 425degC
(ii)	1	40NB	<40 bar(g) AND 425degC
Stand pipe for level measuring instrument			
(i)	2	80 NB	>40 bar(g) OR 425degC
(ii)	1	80 NB	< 40 bar(g) AND 425degC
Flow Measurement			
(i)	2	25NB	> 40bar(g) OR 425degC
(ii)	1	25NB	< 40 bar(g) AND 425degC

Note:-

- 1). Rating of piping / fittings / valves etc. is subjected to the final design pressure & temperature during the detailed engineering, as per ANSI B 31.1.
- 2). In case temperature is more than 540 deg C, the material shall be P-91 only.
- 3). Material shall be compatible with that of the impulse pipe material and design parameter.
- 4). For DM Plant or DM water services, complete erection Hardware material shall be SS316 only.

LOCAL CONTROL PANEL AND DATA SHEET



15.0.0 PANEL AND DESKS

15.1.0 General Requirements

- 15.1.1 All PLC/control system's electronic modules, power supply components, other control devices (except field mounted sensors/transmitters) and required for completeness of the system shall be housed in cabinets furnished by the Bidder. All equipment and dedicated cabinets required for termination, marshalling and proper interface within Bidder's system and also with other systems shall also be provided by the Bidder.
- 15.1.2 The cabinet mounted equipment shall be fully assembled, installed in mounting racks, wired and fully tested as per specification requirements and Owner approved drawings in the manufacturing works of a qualified manufacturer prior to shipment to the project site.
- 15.1.3 The Bidder shall ensure that the cabinets are complete and ready for installation before dispatch from manufacturing works. The installation work at project site for these cabinets should only involve connections through multi pair cables from marshalling cabinets (wherever provided) to system cabinets.
- 15.1.4 The Control cabinets shall house all types of modules / hardware to achieve all functions of Control System including signal conditioning modules, controller modules, I/O modules, communication controller modules, interposing relays and all other requisite hardware for a complete system.

15.2.0 Relay Based Local Control Panel/Desk

- 15.2.1 Local control panel shall be of 2.5 mm steel construction, free standing type, totally enclosed dust and vermin proof with enclosure protection class of IP-65 as per IS: 13947 Exterior color shall be as per shade no. RAL 7032 and Interior color shall be Brilliant white. Panel shall be mounted on vibration dampers secured to steel frame on to the floor. Equipment and relays mounted on the panel shall be easily accessible. The panel shall be supplied completely wired upto terminal blocks for connecting external cables entering the panel from the bottom. Blank removable gland plate shall be provided with double compression type cable glands/conduits knockout along with the panel.
- 15.2.2 Terminal block shall be rated 1100 volts minimum and shall have strap screw less terminals suitable for connection with 2x2.5 sq mm copper conductors on each side. Terminal block shall be provided with white marking strips. Fuses shall not be mounted on terminal blocks. At least 20 percent spare unused terminals shall be provided on terminal block.
- 15.2.3 Relays, timers and other devices mounted on the panel shall have clearly visible identification marking. All fuses shall be HRC semiconductor type of AC supply. HRC link & fuse shall be of removable type having 45 kA rupturing capacity (min) for protection of various circuits.
- 15.2.4 The panel shall be provided with a 50x6 mm tinned copper earthing strip running throughout the length of the panel at the bottom. Panel shall be provided with space heaters with isolating DPN MCB, and thermostats, LED based illuminating lamps, complete with door switches; and 2 nos. 6 pin 5/15amps sockets with DPN MCB.
- 15.2.5 Panel shall have removable lifting eye bolts for safe lifting from top during handling. Control power supply shall be provided from dual redundant feeders with auto change over scheme, surge protection devices and Power/Volt/AM meter.
- 15.2.6 The panel shall be provided with push buttons, indicating lamps, annunciators, indicating instruments, interlock/ deinterlock switches etc., required for the complete system. Colored Mimic for respective plant lay out shall be provided.



15.2.7 20% spare relays of each type and rating shall be mounted and wired in relays control panel/Desk. All contacts of relays shall be terminated in terminal blocks of relay control panel/Desk, Additionally in the relay control panel/Desk, 20% spare terminal blocks shall be provided so that additional relays can be mounted and wired.

15.2.8 The annunciation system shall consist of panel mounted audio-visual windows of 50x75 mm provided with plug-in-type solid-state logic 16 nos. high intensity LEDs in parallel. Each local panel shall be provided with 30 nos min. facia windows. Initiating contacts may be either NO or NC; a jumper or switch shall be provided in each card to make it suitable for either type of contact. A set of acknowledge, reset and test push buttons shall be provided on the panel. All printed circuit boards shall be of epoxy fibre glass construction.

15.2.9 The sequence of annunciation shall be as follows:

Condition	Visual	Audible
Normal OFF	OFF	OFF
Alarm	Flashing	ON
Acknowledge	Steady	OFF
Return to Normal:		
a. Before acknowledge	Flashing	ON
b. After acknowledge	Steady	OFF
Reset:		
a. Alarm condition	No Change	No change
b. Return to normal	OFF	OFF



- 15.3.6 Care shall be taken to ensure ergonomically aspects so as to create ergonomically ideal work place considering physical aspects such as an average Indian person's size and reach, physiological aspects such as line of sight and field of vision and cognitive factors such as concentration and perceptivity. Extreme care shall be taken to design the desks with correct angles and dimensions.
- 15.4.0 **Termination/Marshalling Cabinets & Interposing Relay Panel**
- 15.4.1 Marshalling/Termination cabinets for the system shall be supplied for terminating all cables originating from the field, MCC/SWGR or any other source of signal and for distributing the signals to different functional panels and cubicles.
- 15.4.2 Incoming cables from the field, MCC/SWGR or any other source of signal shall be terminated in suitable terminal blocks in logical sequence.
- 15.4.3 Prefabricated cables with plug in connectors at both ends shall be used for extending the signals to the functional panels. Matching plug sockets shall be provided in the termination cabinets for terminating the plugs.
- 15.4.4 Interposing relay panels for the system shall be supplied for mounting interposing relays & terminating all cables originating from the DO cards and for distributing the signals to different MCC/SWGR panels and cubicles. IPR panels shall be placed in LCR.
- 15.4.5 The cabinet shall have internal illumination lighting fixtures.
- 15.4.6 Terminal blocks shall be located inside the cabinets on support wings fabricated of metal plates.
- 15.4.7 The plug socket shall be mounted on hinged plates to provide an access to the rear pins of the plugs.
- 15.4.8 General features of termination cabinets and accessories shall conform to the general design and construction specification of panels. Terminal blocks shall be Rail mounted Terminal blocks (Screw less cage clamp type) with markers.
- 15.5.0 **Constructional Features Of Panels, Consoles, Cubicles & Enclosures**
- 15.5.1 All panels, cubicles, consoles, SOV panels and enclosures furnished as per this specification shall be of free standing type and shall be constructed of specified gauge of steel plates. The panel sheet thickness shall be not less than 2 mm. vibration isolating
- 15.5.2 The panels, consoles/desks shall be reinforced as required to ensure true surfaces and adequate support for instruments mounted thereon. All instrument cutouts, mounting studs, and support brackets shall be accurately located. All welds on the exposed panel surfaces shall be ground smooth. Finished panel surfaces shall be free from waves, bellies, or other imperfections. Unless specified, otherwise, panel doors shall be 4 points hinged and shall have turned back edges and additional bracing where required to ensure rigidity. Door hinges shall be of the concealed type. Door latches shall be of the three-point type to ensure tight closing. Door locks shall be furnished which will allow actuation of all locks by a single master key. All panels shall have removable lifting fire s for safe lifting from top during storage and installation handling.
- 15.5.3 Cabinet doors shall be hinged and shall have turned back edges and additional bracing where required ensuring rigidity. Hinges shall be of concealed type. Door latches shall be of three-point type to assure tight closing. Detachable lifting eyes or angles shall be furnished at the top of each separately shipped section and all necessary provisions shall be made to facilitate handling without damage. Front and rear doors shall be provided with locking arrangements with a master key for all cabinets. If width of a cabinet is more than 800 mm, double doors shall be provided.



- 15.5.4 All panels shall be mounted on vibration dampers, which are secured to channels mounted on the floor. The channels shall be field welded to steel plates set into the concrete flooring. The steel plates shall be located such as to approximate the outline of panel bases. The exact mounting details shall be as approved by the Owner during detailed engineering stage. All panels shall be provided with adequate ventilation and packaging density of components shall be restricted so as to limit the temperature rise above ambient to 10°C under the worst conditions. All panels shall have auto on/off switch for internal lighting. All the power supply circuit for control panels shall be provided with auto changeover circuitry.
- 15.5.5 In each panel /cabinet, a 24 VDC Voltmeter digital type shall be provided to check the field interrogation voltage.
- 15.5.6 Exhaust fans with louvers & filters shall be provided on upper side to remove hot air in all consoles and panels.
- 15.5.7 Fire/Smoke detectors shall be provided inside the Control room mounted system/control cabinets.
- 15.5.8 Feeder failure/ healthy indication shall be provided in each cabinet & remote indication shall be hooked up to PLC/annunciation & suitably grouped.
- 15.5.9 All the panels shall be equipped with Anti vibration pad of min. 15 mm size. Cable gland plate thickness shall be 3 mm.
- 15.5.10 Doors shall be provided with neoprene gasket only.
- 15.5.11 Surface Preparation and Painting

All panel exterior steel surfaces shall be ground smooth, and painted as specified below: Suitable filler shall be applied to all pits, blemishes and voids in the surfaces. The filler shall be sand blasted so that surfaces are level and flat, corners are smooth and even. Exposed raw metal edges shall be ground burr free. The entire panel surface shall be sand blasted to remove rust and scale and all other residue due to the fabrication operation. Oil grease and salts etc. shall be removed from the panels by one or more solvent cleaning methods. Alternatively 7 tank process shall be followed.

Two spray coats of inhibitive epoxy primer – surface shall be applied to all exterior and interior surfaces; each coat of primer surface shall be of dry film thickness of 1.5 mil. A minimum of two spray coats of final finish colour (Catalyzed epoxy finish) shall be applied to all surfaces of dry film thickness 2.0 mil. The finish colours for exterior and interior surfaces shall conform to the following shades:

Exterior – RAL7035

Interior – Brilliant white

The above color shade shall be applicable and uniformity shall be maintained for the complete plant.

Paint films, which show sags, checks, blisters teardrops, fat edges or other painting imperfections, shall not be acceptable and if any such defects appear, they shall be repaired by and at the expenses of the Bidder.

15.6.0 Panel Wiring

- a. Interconnecting wiring shall be provided between all electrical devices mounted in the panels, and between the devices and terminal blocks if the devices are to be connected to equipment outside the panels. The Bidder shall install jumpers between terminal blocks as indicated on the Owner's schematic diagrams. All alarm contacts



located within a panel shall be wired to terminal blocks. Thermocouple and other special circuits shall be field wires direct to instrument terminal blocks without the use of panel wiring.

- b. All Control and Instrument wiring used within the panels shall conform to NEC and NEMA standards and shall be factory installed and tested at the works of a qualified manufacturer. All interior wiring shall be installed neatly and carefully, and shall be terminated at suitable terminal blocks. Sufficient clearance shall be provided for all Control and Instrumentation leads, and all incoming and outgoing leads shall be connected to terminal blocks suitably located for connecting external circuits. The arrangements for circuits and terminal blocks shall agree with schematic diagrams furnished by the Owner. All panel wiring shall have appropriate ferruling for clear identification. Interior wiring shall be so arranged that the external connections can be made with only one wire per terminal point. Any common connections shall be made internal side of the terminal blocks. Common connections shall be limited to two wires per terminal. Instrumentation cable shield wires shall be connected to separate terminal at the terminal block.
- c. Signal circuit shields shall be grounded at the power supply end only or as recommended by manufacturer.
- d. All internal wiring (except low level instrument wiring) shall be National Electric Code Type SIS, Polymetric/Elastomeric insulated, 1.5mm² tinned copper stranded conductor, switchboard wire, or Owner approved equal.
- e. Panel wiring shall have a flame resistant insulation with adequately sized copper conductor based on current carrying capacities as etc forth by the National Electric Code.
- f. Wire sizes shall be as specified herein and suitable for intended applications.
- g. Wiring to door mounted devices shall be provided with (49 strand minimum) adequate loop lengths of hinge wire so that multiple door openings will not cause fatigue braking of the conductor.
- h. Wiring shall be arranged to enable instruments or devices to be removed and/or serviced without unduly disturbing the wiring. No wire shall be routed cross the face or rear of any device in a manner, which will impede the opening of covers or obstruct access to leads, terminals or devices.
- i. Panel wires shall be identified with wire number and each termination by means of Action craft products split sleeve or Borden Chemical Co. indelible tubing markers or Owner approved equal. Corrections and modifications of all panel wiring shall be Bidder's sole responsibility. Any corrections/modifications required at site for successful commissioning shall be done by the Bidder without any additional costs. Terminal lugs furnished must be of the compression, insulated sleeve, half ring tongue type. Open- ended terminal lugs will not be accepted. Wires shall not be looped around the terminal screws or studs.
- j. Wires shall not be tapped or spliced between terminal points.
- k. Panels, cabinets, consoles/desks will be provided with removable, gasketed cable gland plates and cable glands, for all floor slots used for cable entrance. Split type grommets shall be used for prefab cables.
- l. Internal wiring in factory prewired electronic systems cabinets may be installed according to the Bidder's standard as to wire size, insulation, and method of termination on internal equipment except that insulation for all wiring power supply wiring, and interconnecting cables between devices shall pass the following tests.



- Flammability test IEEE 383/1974
 - When tested under UITPP test method or ASTM 2893/77 light transmittance of 80%
 - When tested under IEC 754-1 maximum acid gas generation shall be 2% by weight
 - Oxygen index not less than 30 as per ASTM D 2863.
- m. All terminations for intra panel wiring inter panel cabling and connecting the Bidders panels, PB stations, control stations etc. shall be with cage clamp Screw less connections. Soldered connections are not acceptable. All field side or external input connections shall also preferably of cage Clamp/ Screwed less connection. Conductor Clamping shall also confirm to Standard IEC – 60947-1 & IEC-60947-7-1. Identification of conductors may be done by insulation colour coding identified on drawings or by printed wiring lists. Terminal blocks for connection of external circuits in to factory prewired electronic system cabinets shall meet all the requirements as described elsewhere in the specification. For all multicore cables, the outer sheath shall satisfy the properties identified above. However, for panel wiring, the wiring insulation shall also satisfy the properties identified above. The internal wiring shall be done in coloured wiring.
- n. Following wire size shall be utilized for internal wiring:
- 1) Current (4-20m A) : 0.75 sq.mm
Low voltage signals
(AI/AO & DI Signals)
 - 2) DO signals, Ammeter/
Voltmeter circuit, control
Switches, indicator, recorder : 1.5 sq.mm
 - 3) Internal illumination : 2.5 sq.mm
 - 4) Size of Power supply cables shall be as below :-
 - i. 1 to 16 Amp -2.5 sq.mm
 - ii. 17 to 20 Amp - 4 sq.mm
 - iii. 21 to 32 Amp - 6 sq.mm
 - iv. 33 to 40 Amp -10 sq.mm
 - v. 41 to 60 Amp -16 sq.mm
 - vi. Power earth - 4 sq.mm

15.7.0 Instruments Mounting

Instruments and relays mounted on the panels shall be easily accessible for repair and replacement without disturbing other equipment their connected wiring. No special tools shall be needed for the purpose.

15.8.0 Panel Illumination

Panels shall be provided with LED based illuminating lamps with door switch and six (6) point 6/16A, 240V AC universal type power sockets with switch for maintenance purposes. These switches shall be with quick make and break mechanism.

15.9.0 Fuse Blocks

Where fuse blocks rated 30 amp. 250 Volts are required by the specifications or the manufacturer's design, they shall be modular type with Bakelite frame and reinforced retaining clips. Blocks shall be class H.2 pole, screw terminal fuse blocks. Blocks for other current and voltage ratings shall be similar in construction.



15.10.0 Fuses

All fuses shall be fast acting semiconductor types for AC supply .For all DC Powered devices, similarly the fuses shall be fast acting compatible to DCDB fuse provisions. All the power supplies shall be provided with the protection of Fast acting semi-conductor fuses & MCB. Make of Fuses shall be GE or Siemens only.

15.11.0 Moulded Case Circuit Breakers

Moulded case circuit breakers used in equipment covered under these specifications shall have not less than 5000 amp, Interrupting capacity at 220 Volts DC 10,000 Amp. Symmetrical interrupting capacity at 240 Volts AC. MCCB shall be provided at each main feeder line like ACDB & DCDB main feeders, PLC main feeder, control panels, UPS circuits etc.

15.12.0 Grounding

All panels and cabinets shall be provided with a continuous bare copper ground bus of minimum 6 mm x 25/50 mm cross section. The ground bus shall be bolted to the panel structure and effectively ground the entire structure. Each Ground bus shall have provision at each end for connection of ground leaks (6 mm x 50 mm GI Flats) by suitable bolting. All system cabinets shall be brought to a common system ground by the bidder. Electronic earthing resistance shall be less than 0.5 ohms.

Each circuit requiring grounding shall be individually and directly connected to the panel ground bus by ring tongue type compression lugs. For electronic system cabinets the system ground bus shall be insulated from the cabinet enclosure and shall be separately connected to the system ground. All system cabinets shall be brought to a common system ground by the bidder.

The Bidder shall furnish his recommendations regarding grounding requirements for all equipment/systems and shall specifically indicate the deviations if any from the above requirements as a part of his proposal.

15.13.0 Terminal Blocks

For all inputs to the system emanating from the field or other systems, the bidder shall furnish terminals suitable for correct size of field cables.

All outputs going to MCC/SWGR terminal blocks, shall be rated 1100 volts minimum and shall have strap screw less terminals suitable for connection of wires with ring tongue type lugs. Standard terminal blocks shall be screw less cage clamps type WAGO/Phoneix make. Terminal blocks shall be approximately sized for larger wire size of higher voltage insulated incoming conductors as necessary. All the TBs used shall be 6.6 polyimide to withstand corrosion and the metallic portion shall be coated against rust /corrosion. All metal parts should be non –ferrous in nature.

Terminal blocks shall be provided with white marking strips and re permitted by the safety codes and standards shall be without covers.

Fuses shall not be mounted on terminal blocks. Neither step type terminal blocks nor angle mounting of terminal blocks will be acceptable.

At least 20 per cent spare unused terminals shall be provided on each terminal block for circuit modifications and for termination of all conductors in a multi-conductor control cable with each panel, enclosure, cubicle, SOV Boxes etc.



15.14.0 Name Plates and Labels

Name plates of adequate size shall be provided for each panel on front and rear of the panel. Instruments/other accessories mounted inside the panels shall have identification marking clearly visible from inside.

Devices to be mounted on the panels shall also be labeled on the panels shall also be labeled on the outside of the panel. Name plates shall be of polyamide sheets with black letters on white background. Name plates shall be attached to the boards by means of stainless steel panhead screws. Fuses provided for protection of various boxes shall be accessible for replacement. Fuse boxes shall be provided with circuit label and fuse rated current and voltage.

15.15.0 Markings/Labels

All markers/labels shall be made of halogen & silicon free polyamide material with inflammability class V2 as per UL 94, ensuring scratch proof printing with the use of environment friendly solvent free ink & latest BLUEMARK UV technology so as to comply the WIPE RESISTANCE according to DIN EN 61010-1/VDE 0411-1.

15.16.0 Assembly and Inspection

As soon as the panel's fabrication is over, Owner shall inspect the panels and further work on the panels, namely assembly, wiring and assembly of components shall be carried out only after the inspection.

15.17.0 Flexible Hoses

Flexible hoses shall be ¼ inch SS flexible hose pipe and with Buna-N liner steel wire braid reinforcement complete with ¼ inch brass/SS316 fittings and shall have swivel male pipe threads. Each hose shall be done meter in length.

**INSTRUMENTATION CABLE, CABLE
INTERCONNECTION AND TERMINATION
PHILOSOPHY**



13.3.8 Instrumentation cable interconnection and termination philosophy

The cable interconnection philosophy to be adopted shall be such that extensive grouping of signals by large scale use of field mounted Group JBs at strategic locations (where large concentration of signals are available, e.g. switchgear) is done and consequently cable with higher number of pairs are extensively used. The details of termination to be followed are mentioned below.

Application		Type of termination		Type of cable
FROM (A)	TO (B)	END A	END B	
Valves/ Dampers drives (Integral Junction box)			Post Mounted Maxi termi/ cage clamp type	N (Overall shielded)
Transmitters			Maxitermi/ cage clamp (rail mounted) type	M (Individually and Overall shielded)
MCC/SWGR			Post mounted Maxi termi/ cage clamp type	N
Local Junction box, MCC / SWGR			Maxitermi/ cage clamp (rail mounted) type	N
Field mounted Instrument / Switches			Maxitermi/ cage clamp (rail mounted) type	N
Inter marshalling termination cabinet			Post mounted Maxitermi / cage clamp type	M & N
Marshalling termination in cabinet			Plug-in connector / Cage clamp type (rail mounted)	M & N
Motor current transducer in MCC			Plug in connector/ Cage clamp type (rail mounted)	M
PLC cabinets			Plug in connector	Mfr's std. However, connection between PLC and the remote I/Os shall be through fibre optic cable by Bidder if length is >300 M & coaxial cable if length <300 M
Detectors / Any loop device	Detector / Isolator / Interface Unit	-	-	Shielded twisted, fire survival mica glass tape cable conforming to IEC 331 & BS6387



Application		Type of termination		Type of cable
FROM (A)	TO (B)	END A	END B	
				(which shall with stand 950°C for 3 hrs).
JB	Fire Alarm Panel			Shielded twisted, Fire survival mica glass tape cable confirming to IEC 331 & BS6387 (which shall with stand 950°C for 3 hrs).

13.3.9 Cable installation and Routing

All cables assigned to a particular duct/conduit shall be grouped and pulled in simultaneously using cable grips and suitable lubricants. Cables removed from one duct/conduit shall not be reused without approval of Owner.

Cables shall be segregated as per IEEE Std.-422. In vertically stacked trays, the higher voltage cable shall be in higher position and instrumentation cable shall be in bottom tier of the tray stack. The distance between instrumentation cables and those of other system shall be as follows:

From 11 kV/6.6 kV/3.3 kV tray system

From 415V tray system

From control cable tray system

Cables shall terminate in the enclosure through cable glands. All cable glands shall be properly gasketed. Fire proof sealing to prevent dust entry and propagation of fire shall be provided for all floor slots used for cable entrance.

All cables shall be identified by tag. Nos. provided in Owner's approved format at both the ends as well as at an interval of 5 meters.

Line voltage drop due to high resistance splices, terminal contacts, insulation resistance at terminal block, very long transmission line etc. shall be reduced as far as practicable.

The cables emanating from redundant equipment / devices shall be routed through different routes.

13.3.10 Cable laying and Accessories

A) Cable laying

Cables shall be laid strictly in line with cable schedule.

B) Identification tags for cables:

Indelible tags to be provided at all terminations, on both sides of wall or floor crossing, on each conduit/duct/pipe entry/exit, and at every 20 m in cable trench/tray.



C) Cable tray numbering and marking:

To be provided at every 10m and at each end of cable way & branch Connection.

D) Joints of cable shall not be permitted.

Buried cable protection

With concrete slabs; route markers at every 20 meters along the route & at every bend.

E) Road crossings

Cables to pass through buried high density PE pipes encased in RCC. At least 300 mm clearance shall be provided between:

- HT Power & LT Power cables,
- LT Power & LT Control/Instrumentation cables,

Spacing between cables of same voltage grade shall be in accordance with the derating criteria adopted for cable sizing.

F) Segregation (physical isolation to prevent fire jumping)

- a) All cable associated with the unit shall be segregated from cables of other units.
- b) Interplant cables of station auxiliaries and unit critical drives shall be segregated in such a way that not more than half of the drives are lost in case of single incident of fire.

G) Cable clamping

All cables laid on trays shall be neatly dressed up & suitably clamped/tied to the tray. For cables in trefoil formation, trefoil clamps shall be provided.

Bidder shall furnish two completely new sets of cable termination kits like Crimping tools, maxi-termi / wire-wrap tools etc., which are required for maintenance of the system as per the type of termination used.



13.3.11 Conduits

All rigid conduits, couplings and elbows shall be hot dipped galvanized rigid mild steel in accordance with IS: 9357 Part-I and Part- II. The conduit interior and exterior surfaces shall have continuous zinc coating with an overcoat of transparent enamel lacker or zinc chromate. Flexible conduit shall be heat resistant lead coated steel, water leak, fire and rust proof. The temperature rating of flexible conduit shall be suitable for actual application.

13.3.12 Type and Acceptance Tests for Instrumentation Cables

After completion of manufacture, type and acceptance tests as specified in relevant standards and herein shall be conducted and requisite number of copies of test certificates as per Distribution Schedule shall be furnished.

The Owner may, at his discretion, waive type tests provided type tests reports of tests carried out on identical materials(s)manufactured by the Bidder in India are furnished. The Bidder shall furnish copies of such type test reports with the Bid or indicate when they expect to make these available. After completion of manufacture, following minimum type and acceptance tests as specified in relevant standards and herein shall be conducted and requisite number of copies of test certificates shall be furnished. The Owner may, at his discretion, waive type tests provided type tests reports of tests carried out on identical materials(s)manufactured by the Bidder in India are furnished. The Bidder shall furnish copies of such type test reports with the Bid or indicate when they expect to make these available.

I. Type Tests:

The type tests shall be carried out on one drum out of every 10 drums or less for each size of cable in each lot, in presence of Owner's representative as per applicable standards in Govt. approved Laboratory if adequate testing facility is not available at works of the supplier.

Sr. No.	Name of Test	Governing standard	Special requirements as per Owner's specification.
1.	Annealing test (for copper)	IS : 8130/84	As per IS: 8130/84
2.	Conductor resistance test		As per G.T.P.
3.	Per sulphate test (for tinned copper wire)	IS : 8130/84	As per IS: 8130/84
4.	Test for armours wires /strips	IS : 3975	As per IS:3975
5.	Test for measurement of DC resistance of armour	IS: 1554 (I)	As per GTP
6.	Test for measurement of thickness of insulation & sheath & other dimensions.	IS 694 / IS : 1554 (I)	As per GTP
7.	Measurement of volume resistivity of HRPVC insulation	IS : 5831-1984	3.5 x 10 ¹⁴ Ohm-cm at 27°C / room temp. (Min). 3.5x10 ¹¹ Ohm-cm at 85°C (Min.)
8.	Tensile strength and elongation test for insulation & sheath.	IS:5831/1984	As per IS:5831/84
9.	Ageing test for insulation & sheath. Loss of mass test for PVC insulation & sheath.	IS:5831/1984	As per IS:5831/84



Sr. No.	Name of Test	Governing standard	Special requirements as per Owner's specification.
10.	Shrinkage test for PVC insulation & sheath.	IS:5831/1984	As per IS:5831/84
11.	Shrinkage test for PVC insulation & sheath	IS:5831/84	As per IS:5831/84
12.	Hot deformation test for PVC insulation & sheath	IS:5831/1984	As per IS:5831/84
13.	Cold bend test for PVC insulation.	IS:5831/1984	As per IS:5831/84
14.	Cold impact test for PVC sheath.	IS:5831/1984	As per IS:5831/84
15.	Heat shock test for PVC insulation & sheath.	IS:5831/1984	As per IS:5831/84
16.	Thermal stability test for PVC insulation and sheath.	IS:5831/1984	As per IS:5831/84
17.	Test for bleeding and blooming of pigments for PVC insulation of sheath.	IS:5831/1984	As per IS:5831/84
18.	Colour fastness to water.	IS:5831/1984	As per IS:5831/84
19.	Colour fastness to day light.	IS:5831/1984	As per IS:5831/84
20.	High voltage test (water immersion test)	IS:1554(I)	IS:1554(I)
21.	Test for rodent & termite repulsion property of sheath.	-	Presence of lead shall be detected.
22.	Oxygen index test on inner & outer sheath material.	ASTM:D-2863/77	Min.29
23.	Temp. index test on inner & outer sheath material	ASTM:D-2863/77	Min.250°C
24.	Acid gas emission test on inner & outer sheath material.	IEC-754-1	Acid gas generation shall be less than 20% by weight.
25.	Smoke Density test on inner & outer sheath material	ASTM-D-2843/77	Min. 40% light transmission during test.
26.	Flammability test on finished cable samples as per following methods: i. Swedish chimney test ii Vertical tray flame propagation test. iii. Single vertical cable fire resistance test.	SS-424-14-75 Cl. F-3 IEEE-383 IEC-332-1	SS-424-14-75 Cl. F-3 IEEE-383 IEC-332-1
27.	Tests for all electrical properties at 20°C & maximum operating temp. as per GTP.	As per GTP	As per GTP

II Routine Test:

Routine test shall be carried in presence of Owner's representative for all types of cables.

- | | | |
|-------------------------|-------------|---------------------------|
| 1. High voltage test | IS:1554 (I) | 2 KV (RMS) for one minute |
| 2. Conductor Resistance | IS:8130/84 | As per GTP Test |



III Acceptance Tests:

Following tests shall be carried out on 1 drum out of every 10 drums or less for each size of cables in each lot, in presence of Owner's representative.

- | | | |
|---|--------------|---|
| 1. High voltage test | IS:1554 (I) | 2 KV (RMS) for one minute |
| 2. Conductor Resistance Test | IS:8130/84 | As per NIT |
| 3. Volume Resistivity | IS:5831-1984 | (i) 3.5×10^{14} -cm
at 27 deg C/room temp (Min)

(ii) 3.5×10^{11} ohm-cm
at 85 deg C Min. |
| 4. Measurement of Mutual capacitance at 0.8 KHZ | | 100 NF/Km (max) |
| 5. Calculation & Verification of Characteristic impedance on the basis of value obtain for mutual capacitance at 0.8 KHZ with the help of following formula | | |

$$Z = \frac{R}{2fc} \quad 320 \text{ Ohms(nominal)}$$

where

- Z = characteristic impedance in ohm
R = Loop resistance of cable per km in ohms at 20 0C
f = Frequency of test in Hz (800)
c = mutual capacitance per km.

- | | | |
|---|-------------|--|
| 6. Measurement of thickness of insulation and sheath & other dimensions | IS:1554 (I) | As per NIT |
| 7. Tensile strength and elongation at break of insulation & sheath | IS:5831/84 | IS:5831/84 |
| 8. Oxygen index test on inner & outer sheath at room temp. | ASTM-D-2863 | Min.29 |
| *9. Temp. index test on inner & outer sheath | --do-- | Min.2500C |
| *10. Acid gas emission test on inner sheath & outer sheath | TEC-754-1 | Max.20% by weight |
| 11. Smoke density test on inner sheath & outer sheath | ASTM-D-2843 | Min.40% light transmission during test |



12. Flammability test	SS-424-14-75 Class F-3	SS-424-14-75 Class F-3
-----------------------	---------------------------	---------------------------

* (If no. of drums selected for acceptance test for a particular cable size are more than one, the tests marked with * i.e. 5 no. 9 & 10 under acceptance tests shall be carried out on one drum only).

13.3.13 Shop Tests

General Requirements:-

1. The equipment as per this section shall be subject to shop tests.
2. The Conductor shall furnish all materials, equipment, tools, instruments, bulkheads, blanking plates and all personnel required for completing these tests.
3. Personnel performing the tests shall be qualified and experienced. Tests shall be performed as many times as necessary to assure Proper quality of materials and workmanship. If any test reveals Unsatisfactory materials or workmanship, such materials shall be Repaired or replaced to the satisfaction of the Owner.
4. Hydrostatic and pneumatic tests shall be performed on all pipes, Tubings and systems supplied by the Bidder and shall conform to ANSI B31.1 – Code for Pressure Piping.
5. Hydrostatic Testing

All instrument piping, which connects to process piping, shall be hydrostatically tested.

13.3.14 Contract Quantities

The Bidder shall furnish, test all required erection hardware which is necessary for proper installation and interconnection of the equipment/systems furnished by the Bidder as per this specification and their integration with main equipment/systems as per the requirements of this section, enclosed installation drawings and other applicable clauses. The Bidder shall furnish, all hardware and accessories to ensure that the equipment/systems furnished form a complete and operational system.

The Bidder's scope of work shall include supply and testing of impulse pipe lines, pipes, pneumatic pipes/tubing, valves, valve manifolds, fittings and all other accessories required for completeness of Impulse Piping System, Sampling piping system and Air piping system covering both air supply and pneumatic signal lines.

The quality of the erection hardware/equipment used for complete instrumentation and control equipment shall meet all the requirements indicated in the foregoing clauses.

The quantities of erection hardware/equipment to be supplied as part of the bid shall be to meet the complete requirements of the Controls and Instrumentation package and make it functional as per final detailed engineering. The erection hardware listed does not include bolts, nuts, angles, clamps, fixtures, glands and other hardware normally required for erection of equipments offered. These items shall be included whether specifically listed or otherwise by the bidder.

14.0.0 FIRE DETECTION AND ALARM SYSTEM

Minimum 1no.of MFAP & 2 nos.of Repeater panels shall be provided for FGD and same shall be interfaced with main plant fire alarm panel. It shall be preferably similar make of already supplied along with main plant package and it shall be interfaced with main MFAP at CCR.

**SIGNAL INTERFACE
BETWEEN
DRIVES AND DCS**

DDCMIS INTERFACE WITH LT MCC (LT)

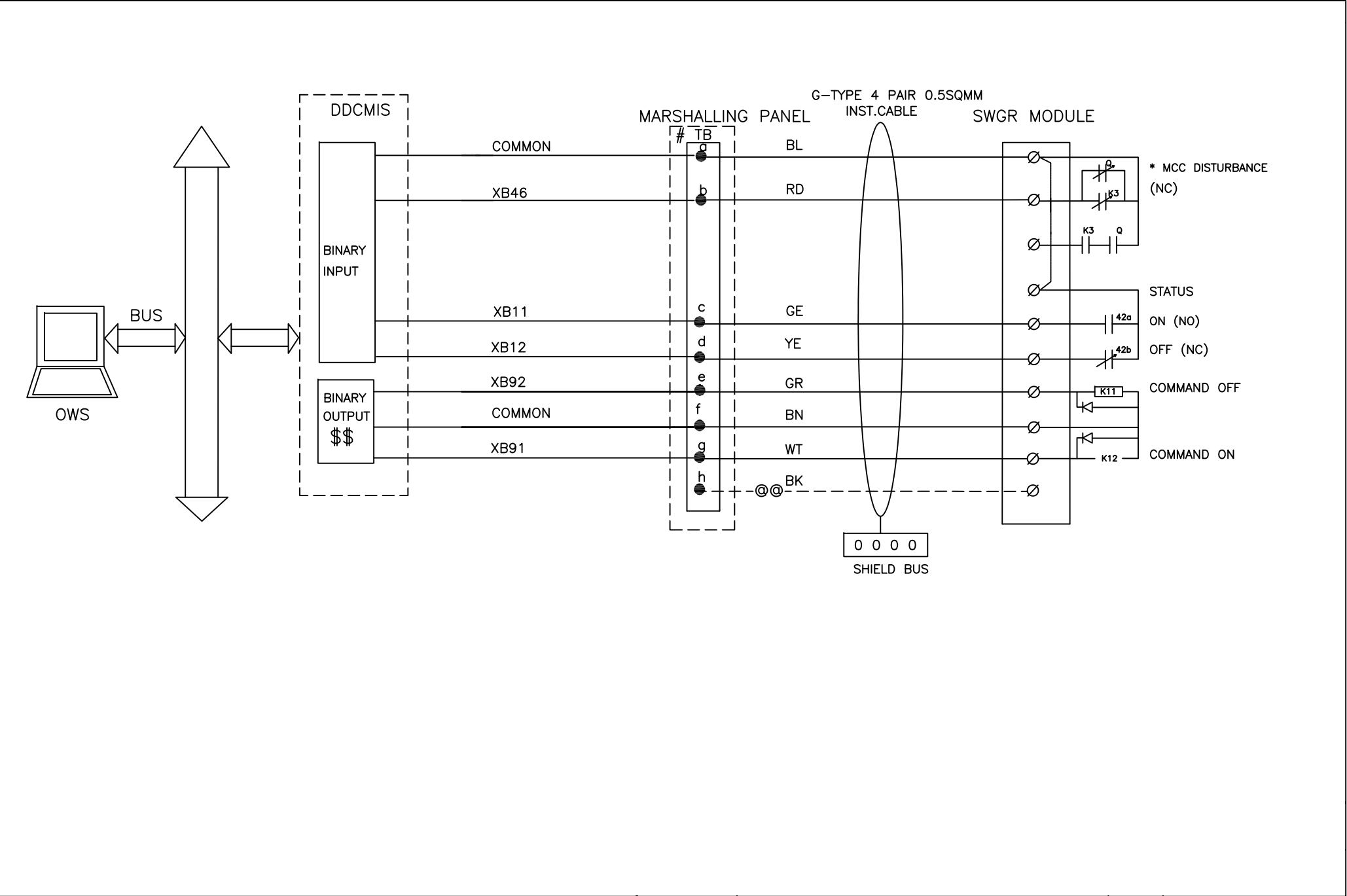

DCS INTERFACE FOR 3-WAY MIXING VALVE (MOD-AC)

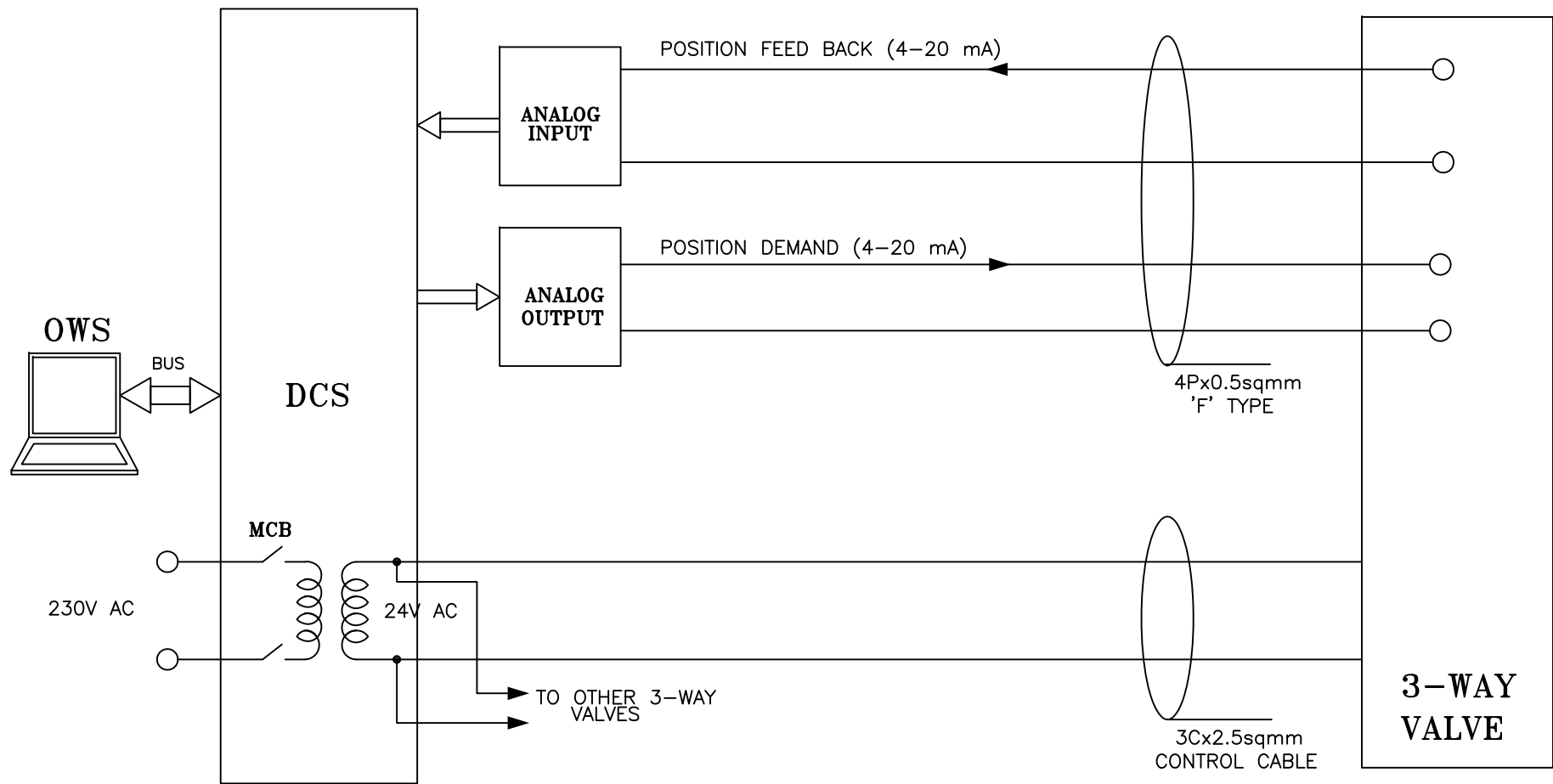

DCS INTERFACE FOR MOTORIZED OPERATED FIRE DAMPER (BID-FD)

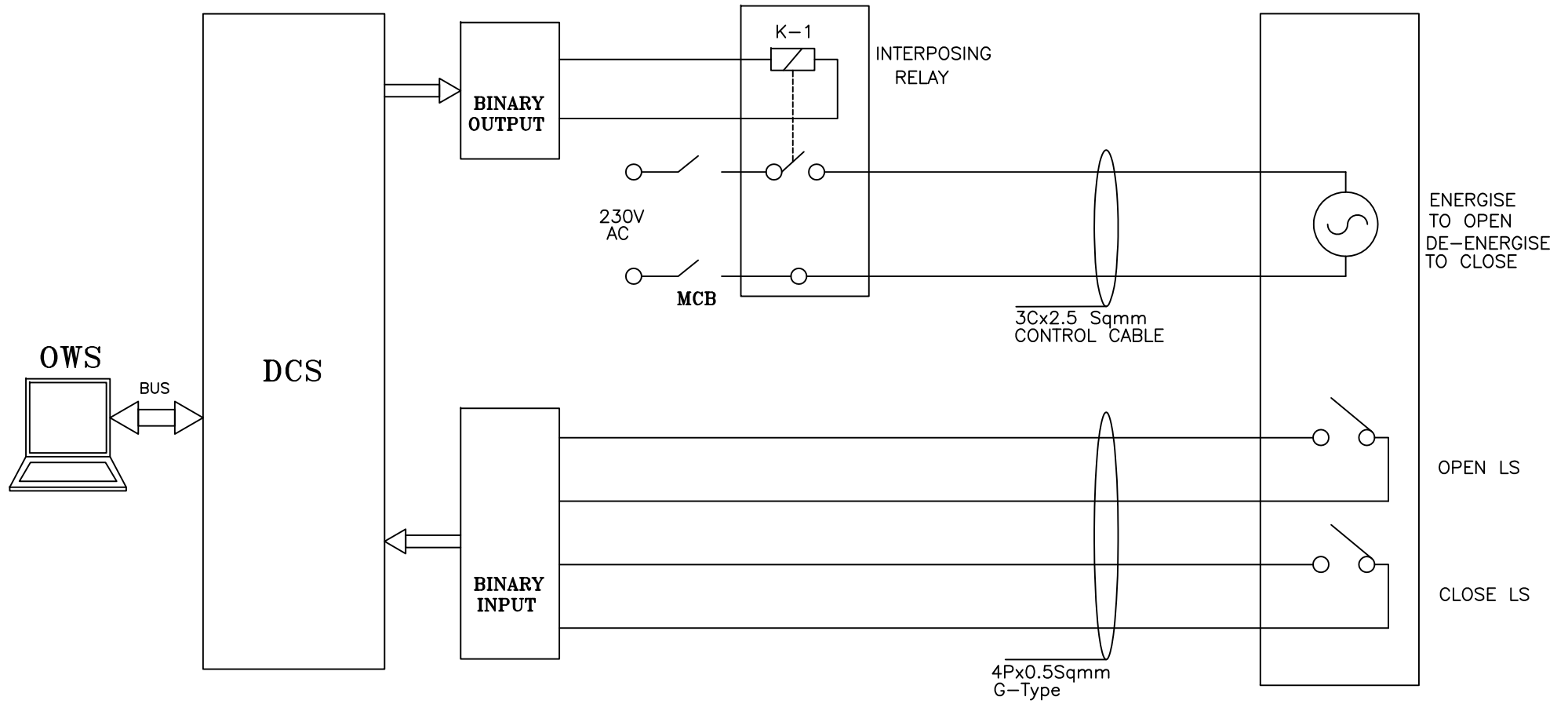

HOOK-UP DIAGRAM FOR ACCU/SCREW CHILLER

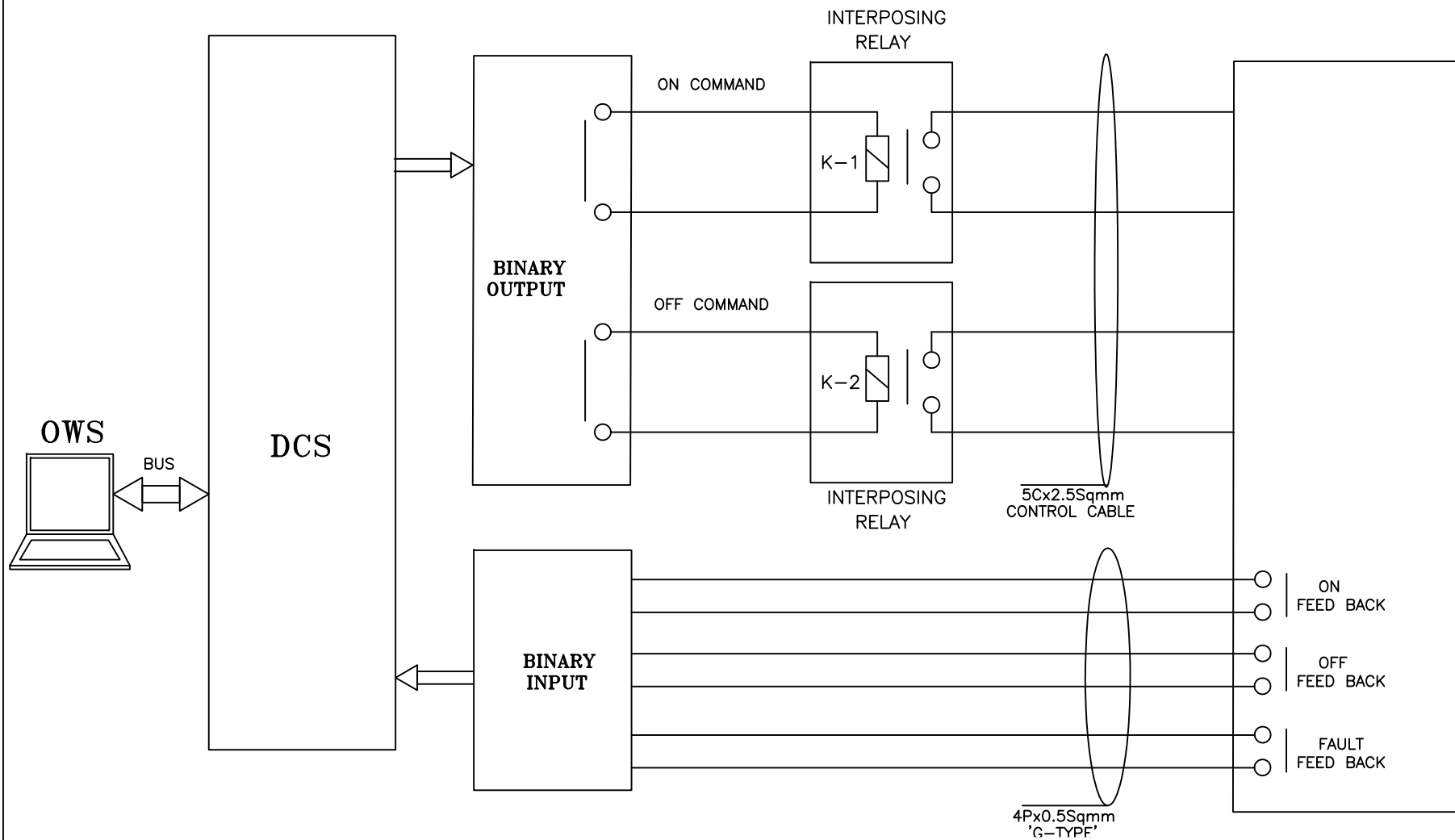

DCS INTERFACE FOR AHUs VFD(VFD-AC)

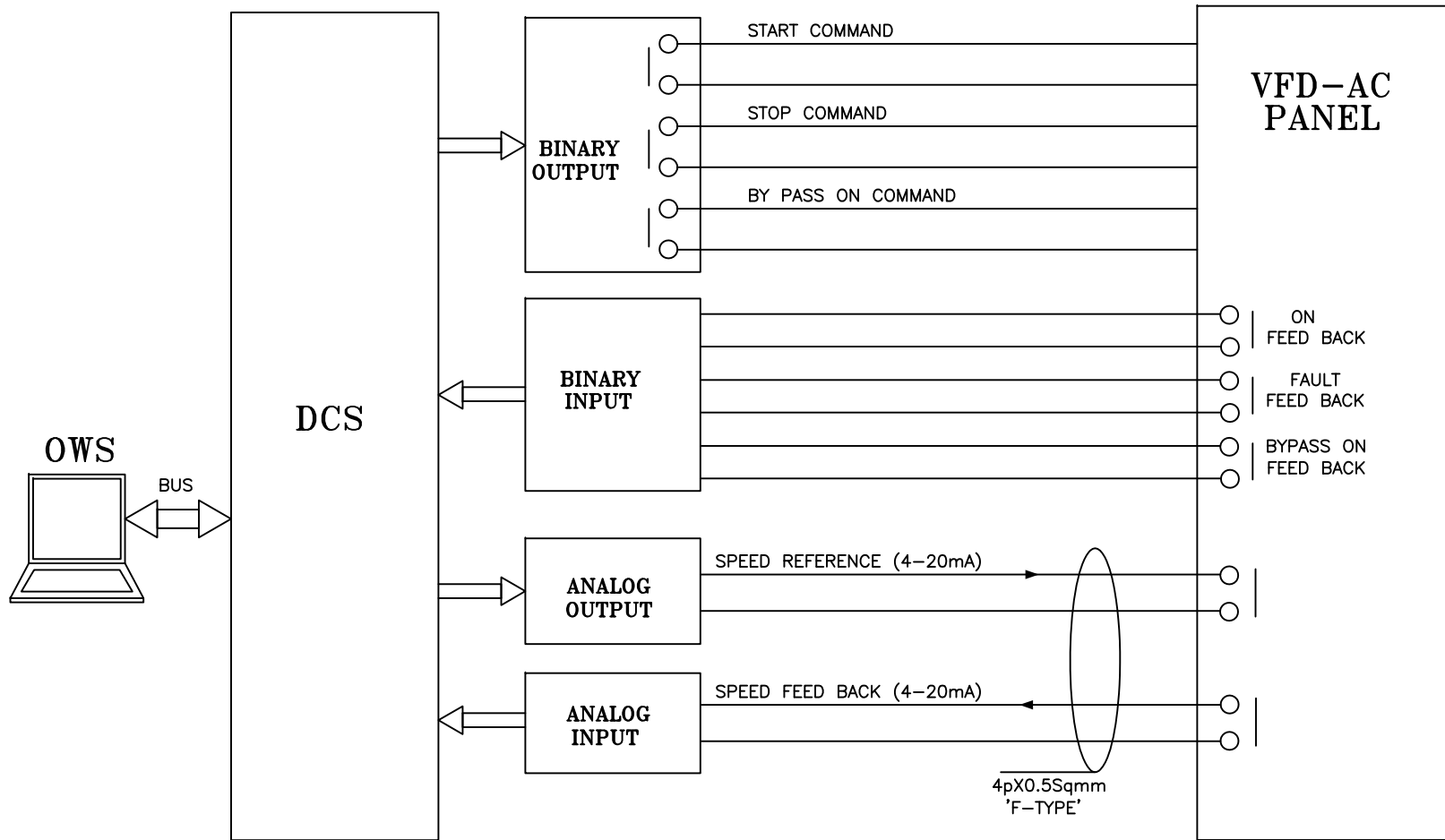

DCS INTERFACE FOR MOTORIZED OPERATED VALVES (BID-AC, BID-VCD)

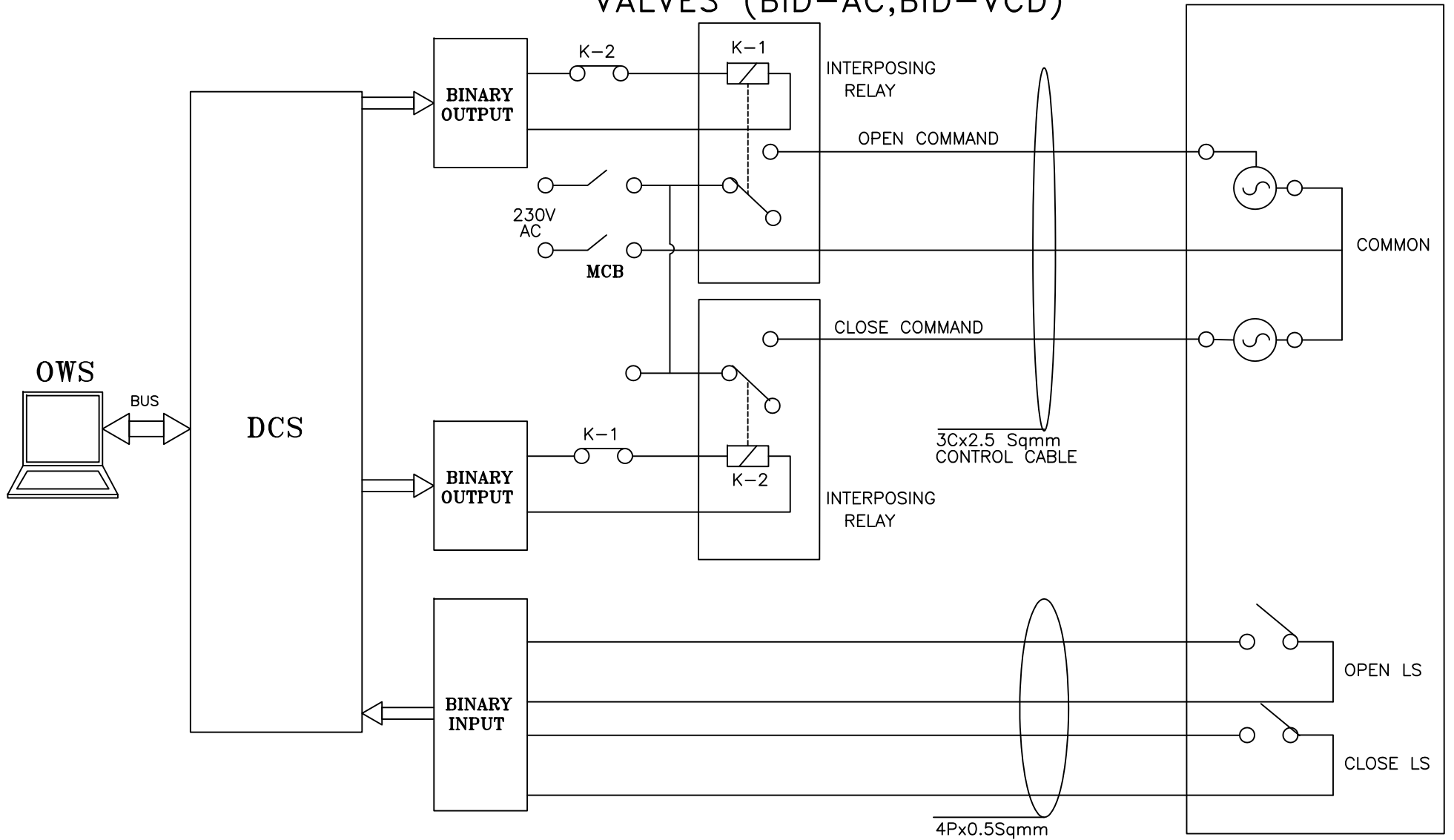

TYPE TEST REQUIREMENTS



16.3.6 Type Test Requirement For C&I Systems

SI No	Item	Test requirement	Standard	Test to be specifically conducted	Owner's approval req. On test certificate	Remarks
Col1	Col2	Col3	Col4	Col5	Col6	Col7
1	Elect. Metering instruments	As per standard (col 4)	IS-1248	No	Yes	
2	Electronic transmitter	As per standard (col 4)	BS-6447/ IEC60770	No	Yes	
3	Instrumentation Cables Twisted & Shielded	No	Yes			
4	Pressure gauge	Degree of protection test	IS-2147	No	No	
		Temp interference test	IS -3624	No	No	
5	Temperature gauge	Degree of protection test	IS-2147	No	No	



SI No	Item	Test requirement	Standard	Test to be specifically conducted	Owner's approval req. On test certificate	Remarks
6	Degree of protection test	Degree of protection test	IS-2147	No	No	
		As per standard (col 4)	BS 6134	No	No	
7	Level switch	Degree of protection test	IS-2147	No	No	
8	Control valves	CV Test	ISA 75.02	No	Yes	
9	Flow Nozzles & Orifice plate	Calibration	ASME PTC, BS 1042	No	Yes	
10	PLCs	All tests as per IEC-1131	IEC-601131	No	Yes	
11	Junction Box	Degree of Protection test	IS-13947	No	Yes	
12	Battery charger (Not required for inbuilt chargers)	Degree of Protection test		No	No	
		Short circuit current capability	IEC-60146-2	No	Yes	
		Temp rise test without redundant fans	Approved procedure, IEC 60146-2	No	Yes	
		SWC test	Approved procedure	No	Yes	
		Burn-in-test	Approved procedure	No	Yes	
		Efficiency	IEC-60146-2	No	Yes	
		Audible Noise test	IEC-60146-2	No	Yes	
		Fuse Clearing capability	Approved Procedure	No	Yes	
		Relative harmonic content	Approved Procedure	No	Yes	
		ESD immunity test	IEC-61000-2-9(1)	No	Yes	
		Radio interference	IEC-60146-2	No	Yes	
		Over load test on Inverter & charger	Approved procedure	No	Yes	
		Restart test	IEC 60146-2	No	Yes	
		Output voltage Harmonic content	Approved procedure	No	Yes	



SI No	Item	Test requirement	Standard	Test to be specifically conducted	Owner's approval req. On test certificate	Remarks
		Insulation test	IEC 60146	No	Yes	
		Load tests	Approved procedure	No	Yes	
		Preliminary light load test	IEC-60146	No	Yes	
		Current division / Voltage division	IEC-60146-2	No	Yes	
13	Battery	As per standard (Col.4)	IEC-623 / IS 10918 for Ni-Cd, IS-1652 for Plante Lead Acid	No	Yes	
14	Voltage	Over Load test	Approved procedure	No	Yes	

QUALTIY ASSURANCE/CHECK LIST



STANDARD CHECK LIST FOR C&I INSTRUMENTS (for Maux Pkgs)

CHECK LIST FOR ANNUNCIATORS

Sl. No.	Test / Checks	Quantum of check	Reference Doc. / Acceptance Norms	Agency **			Remarks
				M	C	B	
1	CHECK FOR	SEE NOTE-1 BELOW	APPROVED SPEC./ DATA SHEETS	P	W	V	
	TYPE/ MODEL						
	DIMENSIONS OF HARDWARE						
	MODULARITY						
	SEQUENCE						
	FACIA DETAILS						
2	FUNCTIONAL TEST	100%		P	W	V	
3	IMMUNE TO STEP VARIATIONS IN THE POWER SUPPLY	SEE NOTE-1 BELOW		P	W	V	
4	DEGREE OF PROTECTION FOR ENCLOSURE	TYPE TEST		P	W	V	
5	I/R CHECK	SEE NOTE-1 BELOW		P	W	V	
6	RESPONSE			P	W	V	

Legend :

** M = Manufacturer / Sub-contractor, C = Contractor / Nominated Inspecting Agency, B = BHEL, P = Perform, W = Witness, V = Verification

Note :

- Quantum of check shall be as below :
100 % - By Manufacturer
- Manufacturer to maintain calibrated instrument having better accuracy than the item under test. Inspecting engineer shall check the same.
- Manufacturer to carry out ROUTINE TEST on 100 %.
- Contractor to provide compliance certificate for tests/checks verified by contractor and submit the same alongwith test certificates to be verified by BHEL.



STANDARD CHECK LIST FOR C&I INSTRUMENTS (for Maux Pkgs)

CHECK LIST FOR TRANSMITTER

Sl. No.	Test / Checks	Quantum of check	Reference Doc. / Acceptance Norms	Agency **			Remarks
				M	C	B	
1	CHECKS FOR	SEE NOTE-1 BELOW	APPROVED SPEC./ DATA SHEETS	P	W	V	
	VISUAL.						
	MODEL/TAG No						
2	PROCESS CONNECTION			P	W	V	
3	ACCURACY			P	W	V	
4	REPEATABILITY			P	W	V	
5	HYSTERESIS	P		W	V		
6	EFFECT OF TEMP VARIATION ON ACCURACY	P		W	V		
7	SPAN / ZERO ADJUSTMENT	ONE / TYPE		P	W	V	
8	EFFECT OF SUPPLY VOLTAGE VARIATION			P	W	V	
9	EFFECT OF LOADING (500 OHM METERS)			P	W	V	
10	HIGH PRESSURE TEST	SEE NOTE-1 BELOW		P	W	V	
11	BURN-IN TEST	ONE / TYPE		P	W	V	
12	DEGREE OF PROTECTION		P	W	V		
13	ACCESSORIES AS APPLICABLE	SEE NOTE-1 BELOW	V	V	V		

Legend :

** M = Manufacturer / Sub-contractor, C = Contractor / Nominated Inspecting Agency, B = BHEL, P = Perform, W = Witness, V = Verification

Note :

1. Quantum of check shall be as below :
100 % - By Manufacturer
2. Manufacturer to maintain calibrated instrument having better accuracy than the item under test. Inspecting engineer shall check the same.
3. When material corelation are not available manufacturer's compliance to be provided.
4. Contractor to provide compliance certificate for tests/checks verifid by contractor and submit the same alongwith test certificates to be verified by BHEL.



STANDARD CHECK LIST FOR C&I INSTRUMENTS (for Maux Pkgs)

CHECK LIST FOR TEMPERATURE ELEMENT

Sl. No.	Test / Checks	Quantum of check	Reference Doc. / Acceptance Norms	Agency **			Remarks		
				M	C	B			
1	CHECK FOR	SEE NOTE-1 BELOW	APPROVED SPEC./ DATA SHEETS	P	W	V			
	TYPE								
	MODEL No./TAG No.								
	PROCESS CONNECTION								
2	STABILITY					P	W	V	
3	INSULATION RESISTANCE					P	W	V	
4	ENCLOSURE CLASS					P	W	V	
5	RESPONSE TIME					P	W	V	
7	ACCURACY					P	W	V	
8	HYDROSTATIC TEST					P	W	V	
9	ELECTRICAL CHARACTERISTIC OF SENSOR (CONTINUITY OF T/C WIRES & INSULATION RESISTANCE OF RTD LEADS w.r.t. BODY					P	W	V	
10	TEMP CURVES / CHARTS					P	V	V	
11	AMBIENT TEMP. EFFECT CHECK			P	W	V			
12	HV TEST			P	W	V			

Legend :

** M = Manufacturer / Sub-contractor, C = Contractor / Nominated Inspecting Agency, B = BHEL, P = Perform, W = Witness, V = Verification

Note :

- Quantum of check shall be as below :
100 % - By Manufacturer
- Manufacturer to maintain calibrated instrument having better accuracy than the item under test. Inspecting engineer shall check the same.
- Contractor to provide compliance certificate for tests/checks verified by contractor and submit the same alongwith test certificates to be verified by BHEL.
- IBR certificate to be provided, if applicable



STANDARD CHECK LIST FOR C&I INSTRUMENTS (for Maux Pkgs)

CHECK LIST FOR SOLENOID VALVES

Sl. No.	Test / Checks	Quantum of check	Reference Doc. / Acceptance Norms	Agency **			Remarks	
				M	C	B		
1	CHECK FOR	SEE NOTE-1 BELOW	APPROVED SPEC./ DATA SHEETS	P	W	V		
	TYPE							
	MAKE							
	MODEL No.							
2	MATERIAL (BODY. PLUNGER/TRIM)			P	W	V		
3	PORT SIZE			P	W	V		
4	CABLE CONNECTION SIZE			P	W	V		
5	ENCLOSURE CLASS			P	W	V		TYPE TEST CERTIFICATE TO BE FURNISHED BY VENDOR
6	No. OF COILS & INSULATION CLASS			P	W	V		TEST CERTIFICATE TO BE FURNISHED FOR INSULATION CLASS BY VENDOR
7	POWER SUPPLY CHECK	P	W	V				
8	IR / HV TEST	P	W	V				
9	FUCTIONAL TEST	P	W	V				

Legend :

** M = Manufacturer / Sub-contractor, C = Contractor / Nominated Inspecting Agency, B = BHEL, P = Perform, W = Witness, V = Verification

Note :

- Quantum of check shall be as below :
100 % - By Manufacturer
- Manufacturer to maintain calibrated instrument having better accuracy than the item under test. Inspecting engineer shall check the same.
- Contractor to provide compliance certificate for tests/checks verifid by contractor and submit the same alongwith test certificates to be verified by BHEL.



STANDARD CHECK LIST FOR C&I INSTRUMENTS (for Maux Pkgs)

CHECK LIST FOR TEMPERATURE GAUGE

Sl. No.	Test / Checks	Quantum of check	Reference Doc. / Acceptance Norms	Agency **			Remarks	
				M	C	B		
1	CHECK FOR	SEE NOTE-1 BELOW	APPROVED SPEC./ DATA SHEETS	P	W	V		
	DIAL SIZE							
	MODEL NO./TAG NO./TYPE							
	RANGE/SCALE							
	END CONNECTION							
2	CALIBRATION	SEE NOTE-1 BELOW	APPROVED SPEC./ DATA SHEETS	P	W	V		
	ACCURACY							
	REPEATABILITY							
	HYSTERESIS							
3	OVER TEMP. TEST			P	W	V		
4	AMBIENT TEMP. COMPENSATION CHECK	1 OF TYPE			P	V	V	
5	REVIEW OF TC FOR MATERIALS OF	FOR LOT	APPROVED SPEC./ DATA SHEETS	V	V	V		
	SENSOR							
	MOVEMENT							
	PROCESS CONNECTION							
	THERMOWELL							
6	REVIEW OF TC FOR DEGREE OF PROTECTION	TYPE TEST			V	V	V	
7	THERMOWELL	SEE NOTE-1 BELOW	AS PER APPD DWG		V	V		
	MATERIAL TC & DIMN. CHECK							
	HYD. TEST							
	OVER RANGE TEST							

Legend :

** M = Manufacturer / Sub-contractor, C = Contractor / Nominated Inspecting Agency, B = BHEL, P = Perform, W = Witness, V = Verification

Note :

- Quantum of check shall be as below :
100 % - By Manufacturer
- Manufacturer to maintain calibrated instrument having better accuracy than the item under test. Inspecting engineer shall check the same.
- Manufacturer to carry out ROUTINE TEST on 100 %.
- IBR certificate to be provided if called for in specn.
- Contractor to provide compliance certificate for tests/checks verified by contractor and submit the same alongwith test certificates to be verified by BHEL.



STANDARD CHECK LIST FOR C&I INSTRUMENTS (for Maux Pkgs)

CHECK LIST FOR PRESSURE & DP GAUGE

Sl. No.	Test / Checks	Quantum of check	Reference Doc. / Acceptance Norms	Agency **			Remarks	
				M	C	B		
1	CHECK FOR	SEE NOTE-1 BELOW	APPROVED SPEC./ DATA SHEETS	P	W	V		
	SENSOR TYPE							
	DIAL SIZE							
	MODEL NO/TAG NO							
	RANGE/SCALE							
	SWITCH CONTACT RATING & NOS.							
	END CONNECTION							
2	CALIBRATION	ONE	APPROVED SPEC./ DATA SHEETS	P	W	V		
	ACCURACY							
	REPEATABILITY							
	SET POINT ADJUSTMENT							
3	OVER PRESSURE & LEAK TEST			P	W	V		
4	OPERATION OF PRESSURE. RELIEF DEVICE	ONE			P	W	V	
5	REVIEW OF TC FOR	FOR LOT	APPROVED SPEC./ DATA SHEETS	V	V	V		
	MATERIALS OF SENSOR							
	MOVEMENT							
	PROCESS CONNECTION							
6	HOUSING			V	V	V		
	REVIEW OF TC FOR DEGREE OF PROTECTION	TYPE TEST			V	V	V	
7	ACCESSORIES AS APPLICABLE	SEE NOTE-1 BELOW			V	V	V	

Legend :

** M = Manufacturer / Sub-contractor, C = Contractor / Nominated Inspecting Agency, B = BHEL, P = Perform, W = Witness, V = Verification

Note :

- Quantum of check shall be as below :
100 % - By Manufacturer
- Manufacturer to maintain calibrated instrument having better accuracy than the item under test. Inspecting engineer shall check the same.
- Manufacturer to carry out ROUTINE TEST on 100 %.
- When material correlation is not available, MFR's compliance to be provided
- Contractor to provide compliance certificate for tests/checks verified by contractor and submit the same alongwith test certificates to be verified by BHEL.

INSTRUMENT HOOK UP DRAWINGS

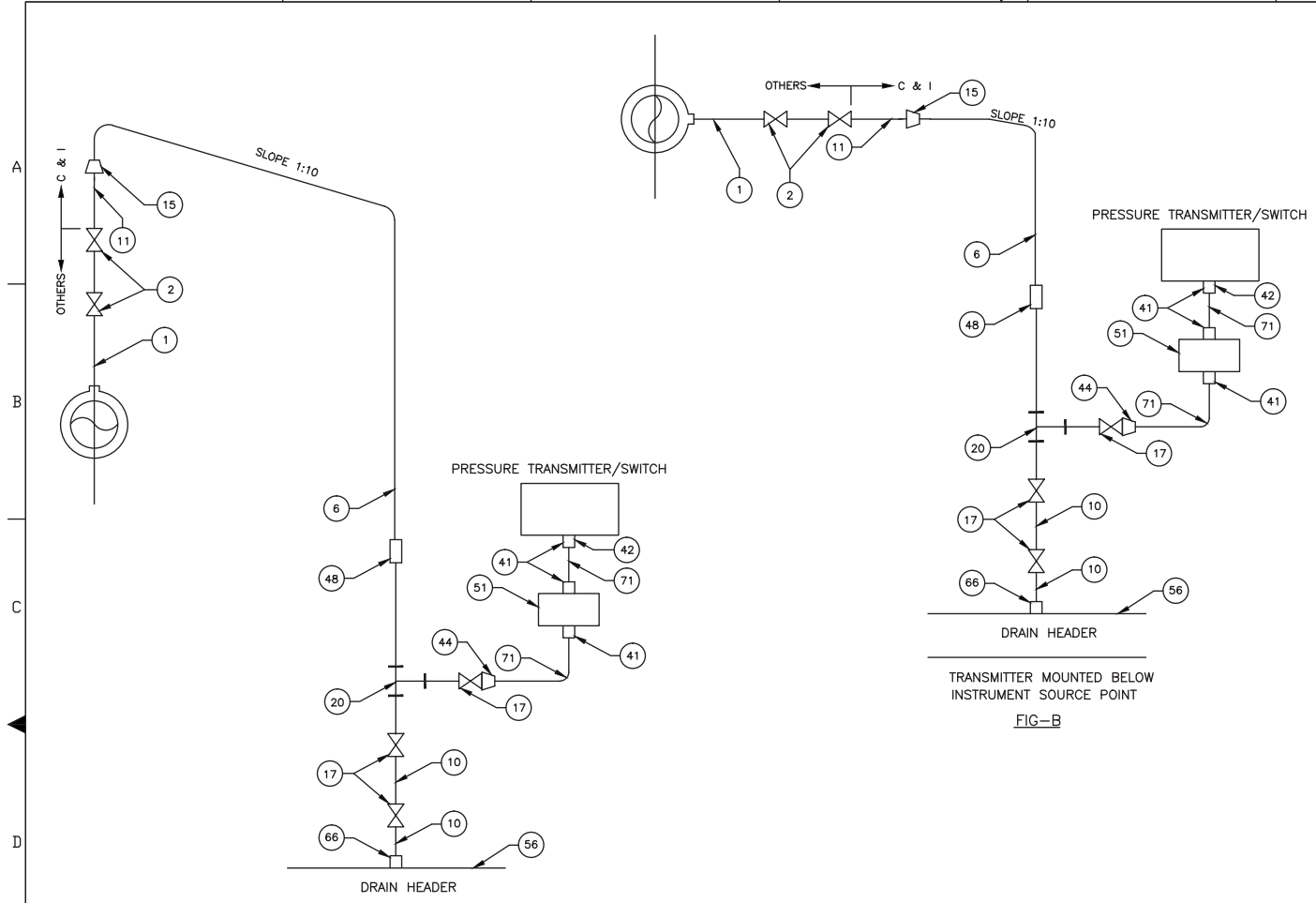

NOTES:-

1. FOR HIGH TEMP. SERVICE (MORE THAN 80°C) A 'U'-TUBE / SYPHON (REF. SHEET NO. 15) SHALL BE PROVIDED BETWEEN THE MANIFOLD AND THE TRANSMITTER/SWITCH.
2. FOR PRESSURE LESS THAN 40KG, ROOT VLV. OF SIZE 1/2"SW, NIPPLE PIECE(11), 1 TO 1/2"SW REDUCER(15) & ISOLATION VALVE(17) ARE NOT REQUIRED.
3. FOR SWITCHES PROCESS CONNECTION SHALL BE NPT(M) & HENCE SL.NO:41 SHALL BE REPLACED BY SL.NO:42.
4. FOR SEA WATER & SLURRY APPLICATION SS SUPER DUPLEX SHALL BE CONSIDERED.
5. FOR LIME STONE SLURRY BASED & SEA WATER APPLICATIONS FLUSH RING & DRAINS SHALL BE PROVIDED.

TRANSMITTER MOUNTED BELOW INSTRUMENT SOURCE POINT
FIG-A

TRANSMITTER MOUNTED BELOW INSTRUMENT SOURCE POINT
FIG-B

TAG NO.	DESCRIPTION	AS REQD.	A	B	QTY.
71	1/2"OD IMPULSE TUBE, SS-316/SS SUPER DUPLEX	AS REQD.			
66	1/2" GI SOCKET	1	1		
56	2"NB GI DRAIN HEADER	AS REQD.			
51	3 VALVE MANIFOLDS, SS-316	1	1		
48	1/2"SW,CS/AS BULK HEAD PIPE UNION	1	1		
44	1/2"SW X 1/2"OD COMPRESSION TUBE FITTING, SS-316/SS SUPER DUPLEX	1	1		
42	1/2"NPT(F) X 1/2"OD TUBE COMPRESSION FITTING, SS-316/SS SUPER DUPLEX	1	1		
41	1/2"NPT(M) X 1/2"OD TUBE COMPRESSION FITTING, SS-316/SS SUPER DUPLEX	3	3		
20	1/2"SW EQUAL TEE,CS	1	1		
17	1/2" SW,CS GLOBE VALVE / NEEDLE VALVE	3	3		
15	1" TO 1/2" SW REDUCER	1	1		
11	1" NPS SCH-80 CS/AS NIPPLE/SS SUPER DUPLEX	1	1		
10	1/2" NPS,SCH 80/160, CS/AS NIPPLE/SS SUPER DUPLEX	2	2		
6	1/2" NPS. SCH-80/160 CS/ AS PIPE/SS SUPER DUPLEX	AS REQD.			
2	1" ROOT VALVE	2	2		
1	1" CARBON/ALLOY STEEL NIPPLE OF MTL. SAME AS THAT OF MAIN PIPE(AS PER PROCESS REQD.)	AS REQD.			

REV.	DATE	DESCRIPTION	DRN.	STR.	MECH.	ELEC.	INST.	APPROVED BY
OC	21.01.19	BASED ON COMMENTS		RV				KA
OB	20.12.18	BASED ON COMMENTS		RV				KA
0A	12.05.17	TENDER PURPOSE		KK				KA

PROJECT : **1 x 800MW NORTH CHENNAI TPP STAGE -III FGD PACKAGE**

OWNER : **TAMILNADU GENERATION & DISTRIBUTION CORPORATION LIMITED**
CHENNAI-600 002, TAMILNADU, INDIA

OWNER'S ENGINEER : **FICHTNER Consulting Engineers (India) Private Limited**
Chennai

	SIGNATURE	DATE	INST. DRAWING FOR PRESSURE & DIFFERENTIAL PRESSURE TRANSMITTER /SWITCH(STEAM & LIQUID SERVICE) - 1
DRAWN	RV	21.01.19	
DESIGNED	KRK	21.01.19	
CHECKED	KRK	21.01.19	
DEPT.HEAD	KA	21.01.19	
PROJ.MGR.	SSR	21.01.19	

DEPT. C&I	JOB NO. 1116127	SCALE: NTS	REV.
DWG.NO. ANNEXURE-7			OC
SHEET: 03 OF 17			

PRESSURE TRANSMITTER

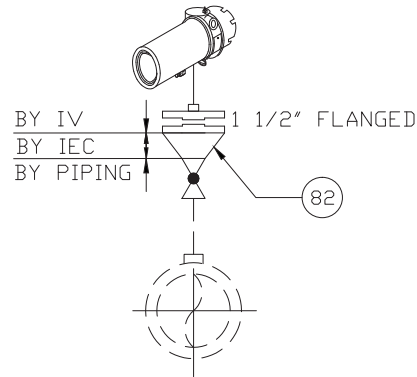

BY IV
BY IEC
BY PIPING

1 1/2" FLANGED

82

OC	21.01.19	BASED ON COMMENTS	RV				KA
OB	20.12.18	BASED ON COMMENTS	RV				KA
OA	12.05.17	TENDER PURPOSE	KK				KA
REV.	DATE	DESCRIPTION	DRN.	STR.	MECH.	ELEC.	INST.
			APPROVED BY				

PROJECT : **1 x 800MW NORTH CHENNAI TPP STAGE -III
FGD PACKAGE**

OWNER : **TAMILNADU GENERATION & DISTRIBUTION CORPORATION LIMITED**
CHENNAI-600 002, TAMILNADU, INDIA

OWNER'S ENGINEER **FICHTNER Consulting Engineers (India) Private Limited**
Chennai

	SIGNATURE	DATE	INST. DRAWING FOR PRESSURE TRANSMITTERS DIAPHRAGM SEAL TYPE				
DRAWN	RV	21.01.19					
DESIGNED	KRK	21.01.19					
CHECKED	KRK	21.01.19					
DEPT. HEAD	KA	21.01.19					
PROJ. MGR.	SSR	21.01.19					

RELEASED L.C.O.S.	PRELIMINARY	DEPT. C&I	JOB NO. 1116127	SCALE: NTS	REV.
	TENDER				
	ENGINEERING	✓	DWG.NO. ANNEXURE-7	180	OC
	CONSTRUCTION				

82	1"x1 1/2" CS EXPANDER, SW, SS316	1
TAG NO.	DESCRIPTION	QTY.
BILL OF MATERIAL		

A
B
C
D
E
F

NOTE:-

- FOR PRESSURE LESS THAN 40KG, ROOT VLV. OF SIZE 1/2"SW, NIPPLE PIECE(11) & 1 TO 1/2"SW REDUCER(15) ARE NOT REQUIRED.
- BIDDER HAS TO PROVIDE SNUBBER AS REQUIRED.
- FOR SEA WATER & SLURRY APPLICATION SS SUPER DUPLEX SHALL BE CONSIDERED.
- FOR LIME STONE SLURRY BASED & SEA WATER APPLICATIONS FLUSH RING & DRAINS SHALL BE PROVIDED.

STEAM/LIQUID SERVICE
FIG-A

AIR SERVICE
FIG-B

TAG NO.	DESCRIPTION	A	B	TAG NO.	DESCRIPTION	A	B
BILL OF MATERIAL		QTY.		BILL OF MATERIAL		QTY.	
20	1/2"SW EQUAL TEE, CS/AS	1	1	78	1/2"NPT(F)x1/2"NPT(M) SNUBBER/PULSATION DAMPER AS APPLICABLE	1	1
17	1/2" SW CS/AS GLOBE VALVE	1	1	59	1/2"SW, STRAIGHT PIPE CONNECTOR, CS/AS	1	AS REQD.
15	1" TO 1/2" SOCKET WELDED REDUCER	1	1	38	3 WAY GAUGE VALVE 1/2" NB SW	1	-
11	1" NPS SCH-80/160 CS/AS NIPPLE/SS SUPER DUPLEX	1	1	37	6" COILED SYPHON SCH 80/160 1/2"NB CS/SS	1	AS REQD.
6	1/2" NPS. SCH-80/160 CS/ AS PIPE/SS SUPER DUPLEX	AS REQD.	32	1/2"NPS,3PIECE PIPE UNION WITH 1/2"NPT(F) SCREWED	1	1	1
2	1/2"/3/4"/1" ROOT VALVE-SW GLOBE VALVE	2	1	28	1/2"NPT (F) CS CAP	1	1
1	1/2"/3/4"/1" CARBON/ALLOY STEEL NIPPLE OF MTL. SAME AS THAT OF MAIN PIPE(AS PER PROCESS REQD.)	AS REQD.	24	1/2"NPS,SCH-80/160x1/2"NPT(M)CS/AS NIPPLE	1	1	1

REV.	DATE	DESCRIPTION	DRN.	STR.	MECH.	ELEC.	INST.
OC	21.01.19	BASED ON COMMENTS	RV				KA
OB	20.12.18	BASED ON COMMENTS	RV				KA
OA	12.05.17	TENDER PURPOSE	KK				KA

PROJECT : **1 x 800MW NORTH CHENNAI TPP STAGE -III FGD PACKAGE**

OWNER : **TAMILNADU GENERATION & DISTRIBUTION CORPORATION LIMITED**
CHENNAI-600 002, TAMILNADU, INDIA

OWNER'S ENGINEER **FICHTNER INDIA** **FICHTNER Consulting Engineers (India) Private Limited**
Chennai

DRAWN	SIGNATURE	DATE
RV		21.01.19
KRK		21.01.19
KRK		21.01.19
KA		21.01.19
SSR		21.01.19

INST. DRAWING FOR LOCAL PRESSURE GAUGE

DEPT. C&I JOB NO. 1116127 SCALE: NTS REV. 181

DWG.NO. ANNEXURE-7 SHEET: 07 OF 17

1 2 3 4 5 6 7 8

PRESSURE GAUGE
WITH DIAPHRAGM
SEAL

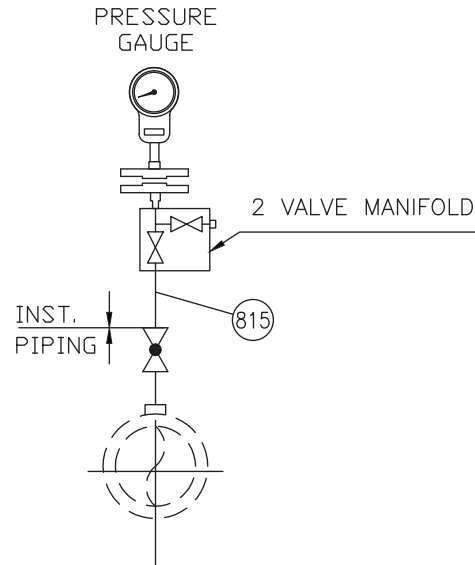

NOTE:-

1. 2 VALVE INTEGRAL MANIFOLD SHALL BE THE PART OF INSTRUMENT VENDOR SCOPE.
2. SNUBBER SHALL BE PROVIDED FOR PUMP DISCHARGE APPLICATION.
3. DIAPHRAGM SEAL SHALL BE PROVIDED FOR CHEMICAL/OILY WATER APPLICATION.

REV.	DATE	DESCRIPTION	DRN.	STR.	MECH.	ELEC.	INST.
OC	21.01.19	BASED ON COMMENTS	RV				KA
OB	20.12.18	BASED ON COMMENTS	RV				KA
OA	12.05.17	TENDER PURPOSE	KK				KA
			APPROVED BY				

PROJECT : **1 x 800MW NORTH CHENNAI TPP STAGE -III
FGD PACKAGE**

OWNER :  **TAMILNADU GENERATION & DISTRIBUTION CORPORATION LIMITED**
CHENNAI-600 002, TAMILNADU, INDIA

OWNER'S ENGINEER **FICHTNER INDIA** **FICHTNER Consulting Engineers (India) Private Limited**
Chennai

	SIGNATURE	DATE
DRAWN	RV	21.01.19
DESIGNED	KRK	21.01.19
CHECKED	KRK	21.01.19
DEPT.HEAD	KA	21.01.19
PROJ.MGR.	SSR	21.01.19

INST. DRAWING FOR
LOCAL PRESSURE GAUGE
DIAPHRAGM SEAL TYPE

TAG NO.	DESCRIPTION	QTY.
1	NIPPLE (100mm), 1/2" NPTM X SW, SCH 80, SS316	1
BILL OF MATERIAL		

RELEASED FOR	PRELIMINARY	DEPT. C&I	JOB NO. 1116127	SCALE: NTS	REV.
	TENDER				
	ENGINEERING		DWG.NO. ANNEXURE-7		OC
	CONSTRUCTION				

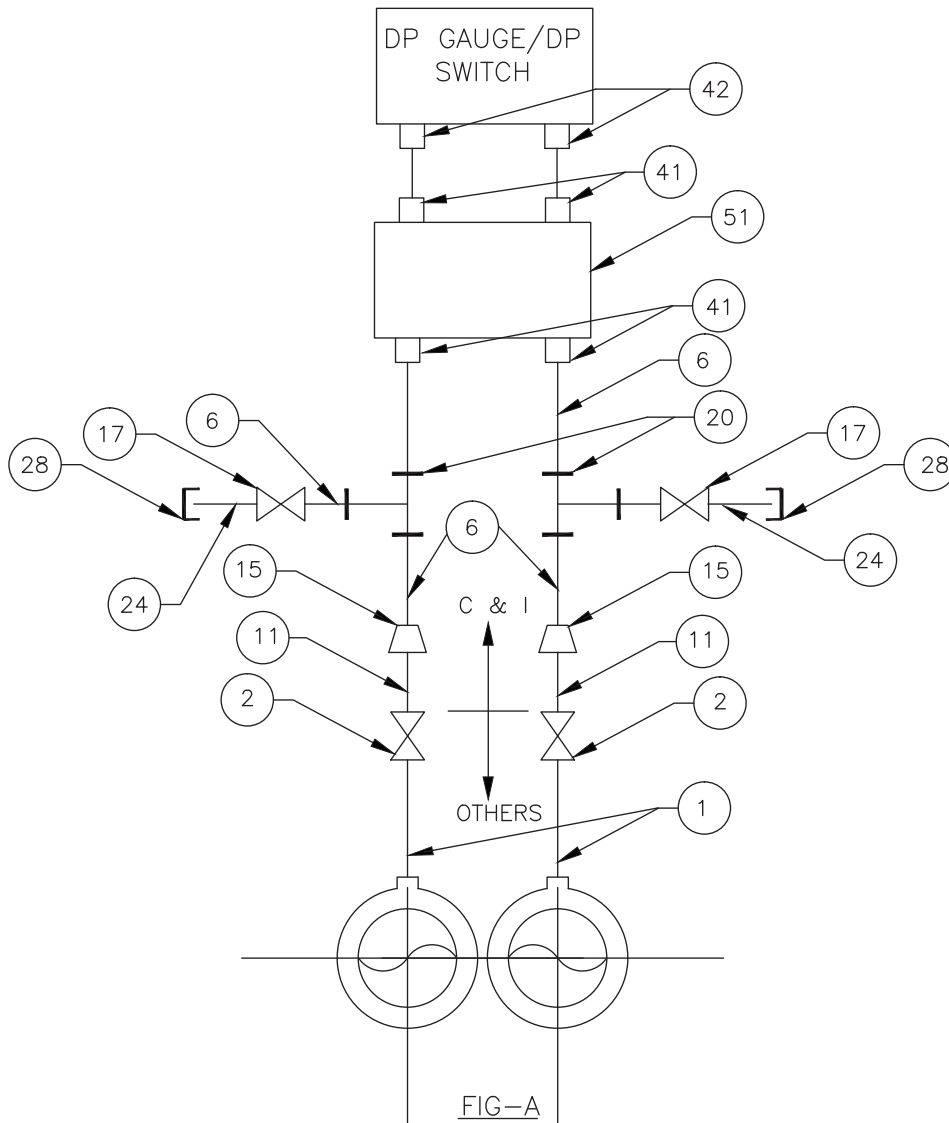

TAG NO.	DESCRIPTION	QTY.
51	3/5 VALVE MANIFOLDS, SS-316	1
42	1/2" NPT(F) X 1/2" OD TUBE COMPRESSION FITTING,SS-316/SS SUPER DUPLEX	2
41	1/2" NPT(M) X 1/2" OD TUBE COMPRESSION FITTING,SS-316/SS SUPER DUPLEX	4
28	1/2" NPT(F) CS. CAP	2
24	1/2" NPS,SCH 80/160 X 1/2" NPT(M) CS/AS NIPPLE/SS SUPER DUPLEX	2
20	1/2"SW EQUAL TEE CS/AS	2
17	1/2" SW,CS/AS, GLOBE VALVE	2
15	1" TO 1/2" SOCKET WELD REDUCER	2
11	1"NPS SCH 80/160 CS/AS NIPPLE/SS SUPER DUPLEX	2
6	1/2"NPS,SCH 80/160 CARBON/ALLOY STEEL PIPE/SS SUPER DUPLEX	AS REQD.
2	1/2*3/4"/1" ROOT VALVE - SW GLOBE VALVE	2
1	1/2"/3/4"/1" CARBON/ALLOY STEEL NIPPLE OF MTL SAME AS THAT OF MAIN PIPE (AS PER PROCESS REQD.)	AS REQD.

NOTE:-

- FOR PRESSURE LESS THAN 40KG, ROOT VLV. OF SIZE 1/2"SW, NIPPLE PIECE(11) & 1 TO 1/2"SW REDUCER(15) ARE NOT REQUIRED.
- FOR SEA WATER & SLURRY APPLICATION SS SUPER DUPLEX SHALL BE CONSIDERED.
- FOR LIME STONE SLURRY BASED & SEA WATER APPLICATIONS FLUSH RING & DRAINS SHALL BE PROVIDED.

REV.	DATE	DESCRIPTION	DRN.	STR.	MECH.	ELEC.	INST.	APPROVED BY
OC	21.01.19	BASED ON COMMENTS	RV					KA
OB	20.12.18	BASED ON COMMENTS	RV					KA
OA	12.05.17	TENDER PURPOSE	KK					KA

PROJECT : **1 x 800MW NORTH CHENNAI TPP STAGE -III FGD PACKAGE**

OWNER : **TAMILNADU GENERATION & DISTRIBUTION CORPORATION LIMITED**
CHENNAI-600 002, TAMILNADU, INDIA

OWNER'S ENGINEER : **FICHTNER Consulting Engineers (India) Private Limited**
Chennai

	SIGNATURE	DATE
DRAWN	RV	21.01.19
DESIGNED	KRK	21.01.19
CHECKED	KRK	21.01.19
DEPT.HEAD	KA	21.01.19
PROJ.MGR.	SSR	21.01.19

RELEASED FOR	PRELIMINARY	DEPT. C&I	JOB NO. 1116127	SCALE: NTS	REV.
	TENDER				
	ENGINEERING	DWG.NO.	ANNEXURE-7		OC
	CONSTRUCTION				

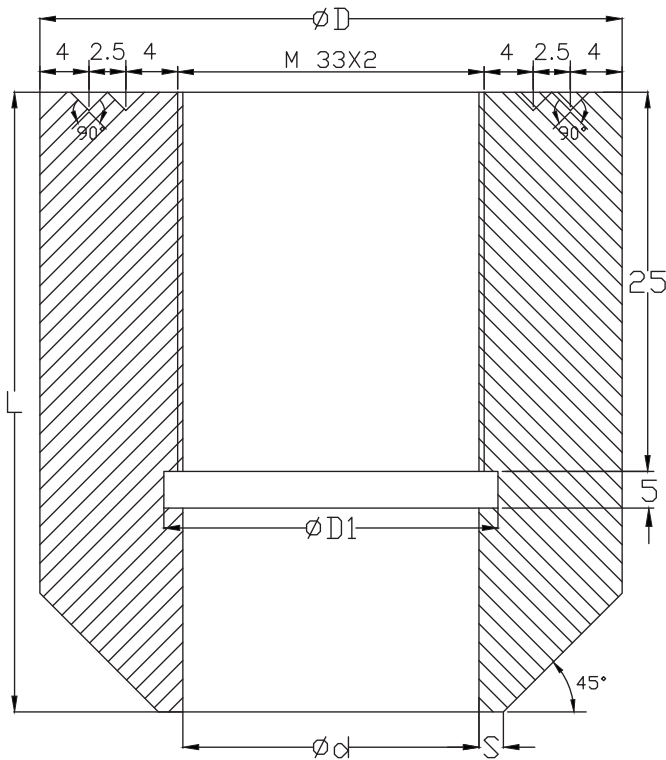

TEMPERATURE STUB FOR STRAIGHT IMMERSION

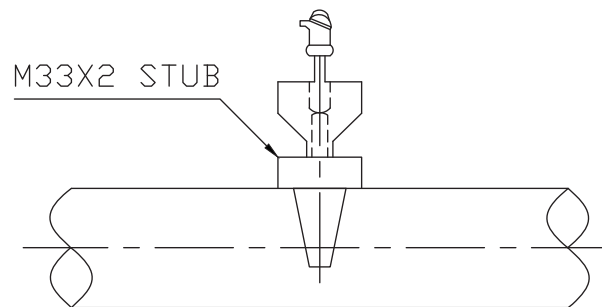

INSTALLATION TYPE-1
(FOR MAIN PIPE OD 168.3MM & ABOVE)

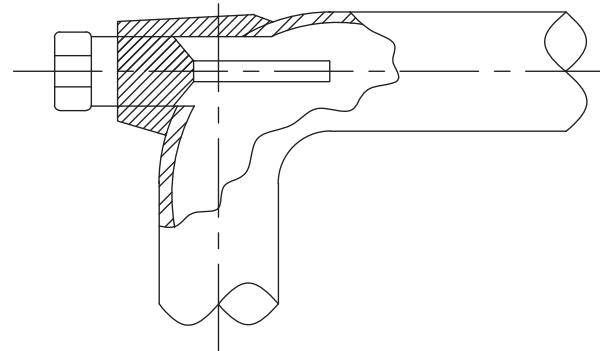

INSTALLATION TYPE-2
(FOR MAIN PIPE OD 88.9MM & BELOW)

NOTES:-

1. MATERIAL OF THE BOSS SHALL BE THE SAME AS THE PIPE INTO WHICH IT IS WELDED.
2. STRAIGHT IMMERSION STUBS SHALL BE USED FOR PIPE OD'S 168.3mm AND ABOVE. THE STUB HEIGHT FOR PIPE OD, 168.3mm TO <219.1mm SHALL BE 65mm.
3. SLANT IMMERSION STUBS SHALL BE USED FOR PIPE OD'S 88.9mm TO 159mm.
4. FOR MAIN PIPE OD'S 88.9mm & BELOW SUITABLE EXPANDER SHALL BE USED.

FOR PIPE OD BELOW 219.1mm	29	55	33.5	1.5	65
FOR PIPE OD 219.1mm & ABOVE	29	55	33.5	1.5	45
MAIN PIPE SIZES	d	D	D1	S	L

OC	21.01.19	BASED ON COMMENTS	RV		KA
OB	20.12.18	BASED ON COMMENTS	RV		KA
OA	12.05.17	TENDER PURPOSE	KK		KA
REV.	DATE	DESCRIPTION	DRN.	STR.	MECH. ELEC. INST. APPROVED BY

PROJECT : **1 x 800MW NORTH CHENNAI TPP STAGE -III FGD PACKAGE**

OWNER : **TAMILNADU GENERATION & DISTRIBUTION CORPORATION LIMITED**
CHENNAI-600 002, TAMILNADU, INDIA

OWNER'S ENGINEER **FICHTNER INDIA** **FICHTNER Consulting Engineers (India) Private Limited**
Chennai

DRAWN	RV	21.01.19	INST. DRAWING FOR TEMP. STUB-1
DESIGNED	KRK	21.01.19	
CHECKED	KRK	21.01.19	
DEPT. HEAD	KA	21.01.19	
PROJ. MGR.	SSR	21.01.19	

RELEASED FOR	PRELIMINARY	DEPT. C&I	JOB NO. 1116127	SCALE: NTS	REV.
	TENDER				OC
	ENGINEERING	DWG.NO.	ANNEXURE-7		
	CONSTRUCTION				

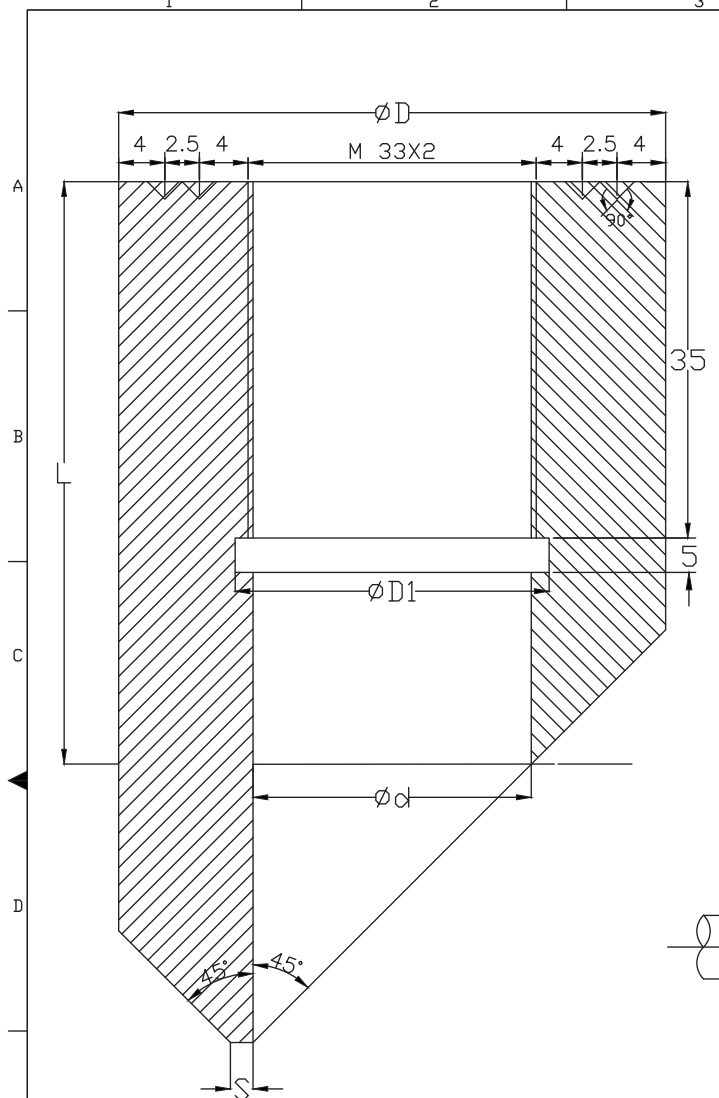

TEMPERATURE STUB FOR STRAIGHT IMMERSION

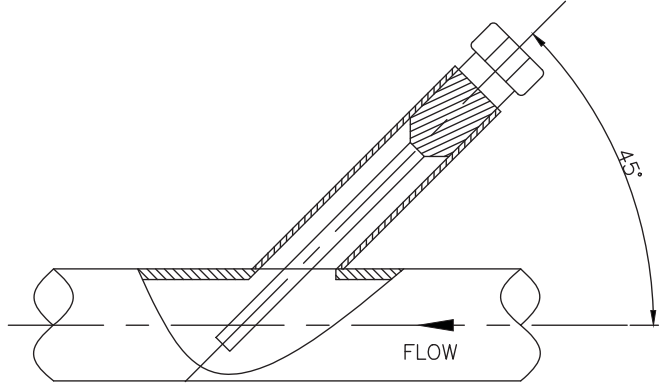

INSTALLATION TYPE-3
(FOR MAIN PIPE OD 88.9mm & 159mm)

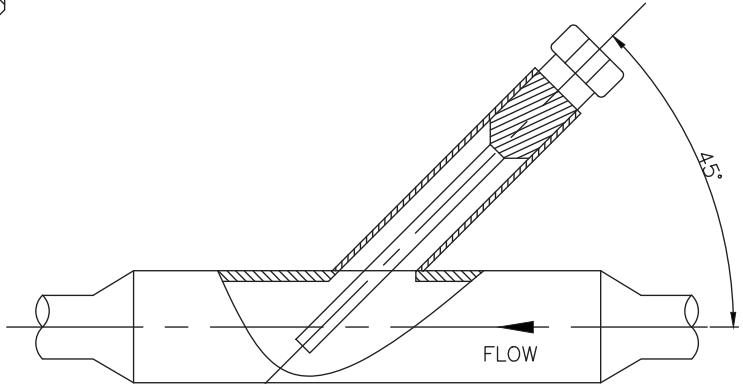

INSTALLATION TYPE-4
(FOR MAIN PIPE OD 88.9mm & BELOW)

NOTES:-

1. MATERIAL OF THE BOSS SHALL BE THE SAME AS THE PIPE INTO WHICH IT IS WELDED.
2. STRAIGHT IMMERSION STUBS SHALL BE USED FOR PIPE OD'S 168.3mm AND ABOVE. THE STUB HEIGHT FOR PIPE OD, 168.3mm TO <219.1mm SHALL BE 65mm.
3. SLANT IMMERSION STUBS SHALL BE USED FOR PIPE OD'S 88.9mm TO 159mm.
4. FOR MAIN PIPE OD'S 88.9mm & BELOW SUITABLE EXPANDER SHALL BE USED.

FOR PIPE OD BELOW 219.1mm	29	55	33.5	1.5	65
FOR PIPE OD 219.1mm & ABOVE	29	55	33.5	1.5	45
MAIN PIPE SIZES	d	D	D1	S	L

OC	21.01.19	BASED ON COMMENTS	RV		KA
OB	20.12.18	BASED ON COMMENTS	RV		KA
OA	12.05.17	TENDER PURPOSE	KK		KA
REV.	DATE	DESCRIPTION	DRN.	STR.	MECH. ELEC. INST. APPROVED BY

PROJECT : **1 x 800MW NORTH CHENNAI TPP STAGE -III FGD PACKAGE**

OWNER : **TAMILNADU GENERATION & DISTRIBUTION CORPORATION LIMITED**
CHENNAI-600 002, TAMILNADU, INDIA

OWNER'S ENGINEER **FICHTNER INDIA** **FICHTNER Consulting Engineers (India) Private Limited**
Chennai

DRAWN	RV	21.01.19	INST. DRAWING FOR TEMP. STUB-2
DESIGNED	KRK	21.01.19	
CHECKED	KRK	21.01.19	
DEPT. HEAD	KA	21.01.19	
PROJ. MGR.	SSR	21.01.19	

RELEASED FOR	PRELIMINARY	DEPT. C&I	JOB NO. 1116127	SCALE: NTS	REV.
	TENDER				
	ENGINEERING	DWG. NO.	ANNEXURE-7		OC
	CONSTRUCTION				

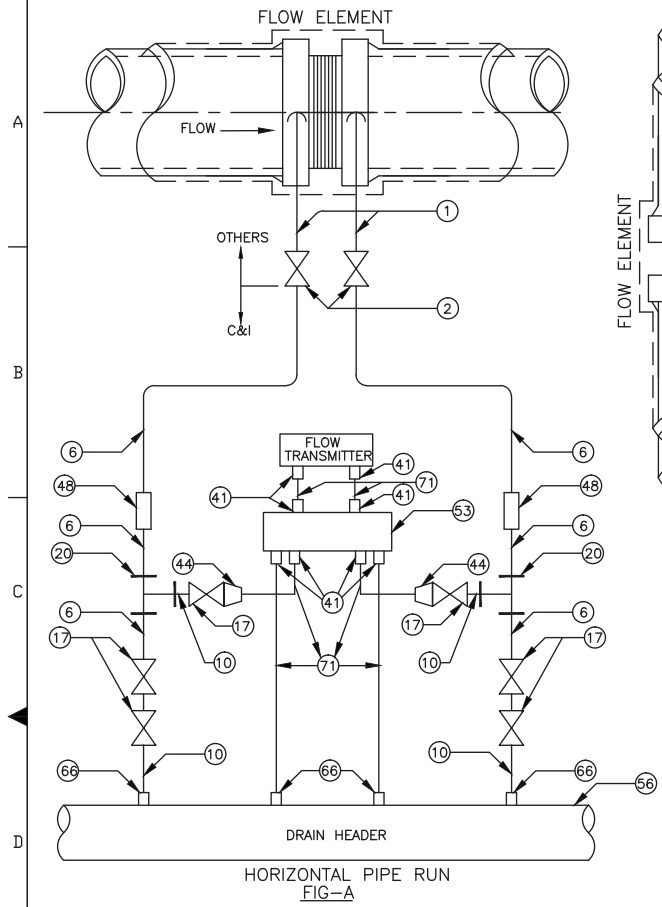

HORIZONTAL PIPE RUN
FIG-A

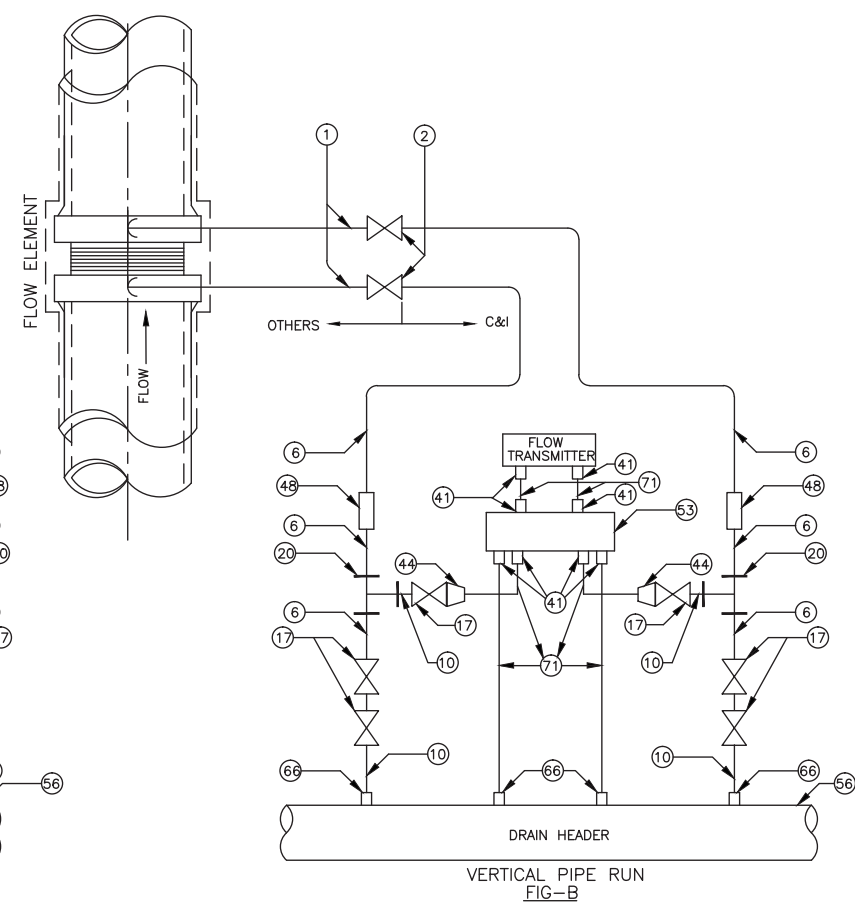

VERTICAL PIPE RUN
FIG-B

NOTE:-
1. FOR SEA WATER APPLICATION MATERIAL FROM THE FLANGE SHALL BE SS SUPER DUPLEX.

OC	21.01.19	BASED ON COMMENTS	RV			KA
OB	20.12.18	BASED ON COMMENTS	RV			KA
OA	12.05.17	TENDER PURPOSE	KK			KA
REV.	DATE	DESCRIPTION	DRN.	STR.	MECH. ELEC.	INST. APPROVED BY

PROJECT : **1 x 800MW NORTH CHENNAI TPP STAGE -III FGD PACKAGE**

OWNER : **TAMILNADU GENERATION & DISTRIBUTION CORPORATION LIMITED**
CHENNAI-600 002, TAMILNADU, INDIA

OWNER'S ENGINEER : **FICHTNER Consulting Engineers (India) Private Limited**
Chennai

DRAWN	SIGNATURE	DATE	INST. DRAWING FOR FLOW MEASUREMENT
	RV	21.01.19	
	KRK	21.01.19	
	KA	21.01.19	
	SSR	21.01.19	
DEPT. C&I	JOB NO. 1116127	SCALE: NTS	REV.
DWG.NO.	ANNEXURE-7		OC

TAG NO.	DESCRIPTION	A	B	TAG NO.	DESCRIPTION	A	B
20	1/2" SOCKET WELDED EQUAL TEE CS/AS	2	2	71	1/2"OD IMPULSE TUBE, SS-316	AS REQD.	
17	1/2" SOCKET WELDED CS GLOBE VALVE	6	6	66	1/2" GI SOCKET / FUNNLE	4	4
10	1/2" NPS SCH 80/160,CS/AS NIPPLE	4	4	56	2"NB GI DRAIN HEADER	AS REQD.	
6	1/2" NPS SCH 80/160 CS/AS PIPE	AS REQD.		53	5-VALVE MANIFOLD, SS-316	1	1
2	1/2" SOCKET WELDED GLOBE VALVE	2	2	48	1/2" SW, CS/AS BULK HEAD PIPE UNION	2	2
1	1/2" NPS SCH 80 NIPPLES OF MATERIAL SAME AS MAIN PIPE WITH NECESSARY ATTACH TO FLANGES	AS REQD.		44	1/2"SWX1/2"OD COMPRESSION TUBE FITTING,SS-316	2	2
				41	1/2"NPT(M)X1/2"OD TUBE COMPRESSION FITTING,SS-316	8	8

MANDATORY SPARES



1.21.0 AIR CONDITIONING AND VENTILATION SYSTEM

Sl.No.	Description	Nos./Sets
1.0	Air handling unit (for each model)	
1.1	V-belts for AHU Blower	2 Sets
1.2	AHU Blower bearing	1 Set
1.3	Blower motor bearing	1 Set
1.4	Filters at suction and discharge of all AHUs	25% of installed population
2.0	Unitary air filtration unit	
2.1	Supply Air fans	
2.1.1	V-belts for supply air fans	2 Sets
2.1.2	Supply air fan bearings	1 Set
2.2	UAF Pump	
2.2.1	Pump bearings	1 Set
2.2.2	Impeller for pump	1 no.
2.2.3	Pump Shaft	1 no.
2.2.4	Shaft sleeves	1 Set
2.2.5	Gland Packings for pumps	1 Set
2.2.6	Nylon Filter	1 Set
2.2.7	Spray nozzles	5% of total population or 50 Numbers whichever is higher.
2.2.8	Water strainer	1 No.
2.2.9	Brass suction screen/strainer for unitary air filtration tank.	1 Set
2.2.10	Motor for Centrifugal fan for UAF	1 No
3.0	Control & Instrumentation	
i)	Air-Conditioning System	
3.1	Electronic Transmitters	
3.1.1	Transmitters of all types and model no. (for the measurement of Pressure, differential pressure flow, level, temperature etc.)	5% or 1 No. of each type and model whichever is more. (to be divided into various ranges in proportion to main population)
3.2	Temperature elements	
	RTD's	5% or 1 No. whichever is more **
	Thermo well * (With head assembly, terminal block and nipple)	5% or 1 No. whichever is more ** ** (to be divided into various insertion lengths in proportion to main population)



SI.No.	Description	Nos./Sets
	All types of Local Indicators	5% or 1 No. of each make, model and type whichever is more (to be divided to various ranges in proportion to main population of all make, model and type)
	Process Actuated Switch Devices Includes all types of Pressure, differential pressure, flow, and temperature, and differential temperature, level switch Devices.	5% or 1No. of each type and model whichever is more.
	Relative Humidity Sensors	1 No.
	Geyserstat	1 No.
	Local Humidity/Temperature indicators	2 Nos. each
4.0	Process Connection Piping (for Impulse Piping / Tubing, Sampling Piping / Tubing and Air Supply Piping as Applicable)	
4.1	Valves	10% or 1 No. of each type, class, size and model whichever is more
4.2	2 way, 3way, 5way valve manifolds	2 way, 3way, 5way valve manifolds
4.3	Fittings	2 way, 3way, 5way valve manifolds
	(II) Ventilation System	
5.0	Measuring Instruments	
5.1	Pressure gauge	1 No. (for centrifugal pumps of UAF units).
5.2	Level transmitter	1 No. (for UAF units)
5.3	Pressure transmitter	1 No. (for UAF Units)
6.0	Process Connection Piping (for Impulse Piping / Tubing, Sampling Piping / Tubing and Air Supply Piping as Applicable)	
6.1	Valves	1 no. of each type, class, size and Model
6.2	2 way valve manifold	1 no. of each type, class, size and model
6.3	Fittings	1 no. of each type, class, size and model

SUB VENDOR LIST

SUB VENDOR LIST FOR C&I ITEMS

Sl No	Package Code	Package Name	Supplier Name	Supplier Communication Address	Supplier Works Address
11	145-45000-A	INSTRUMENT FITTINGS	Arya Crafts & Engineering Pvt. Ltd.	Mr.Sanjay Brahman/Mr.Shyam Vazirani 102, Vora Industrial Estate No.4 Navghar, Vasai Road (E) Dist.Thane, Mumbai Phone- +91-250-2392246 Pincode : 401210 Email : arya@aryaengg.com	
12	145-45000-A	INSTRUMENT FITTINGS	AURA INCORPORATED	NIRAJ SHARAN/SUJIT KUMAR W-167A, GREATER KAILASH-II NEW DELHI Phone- 9810182430 Pincode : 110048 Email : nirai@aurainc.com	
13	145-45000-A	INSTRUMENT FITTINGS	Comfit & Valve Pvt. Ltd.	Mr. Jeetu Jain/Mr. Vinay Sosa Survey No. 23/1, Part 2, Ahmedabad-Mehsana Highway Laxmipura, Nandasana Phone- 02764-267036/37 Pincode : 382705 Email : marketing@com-fit.com	Works-1->Miss Sonal Pithadia/Miss Pavan Chavda Survey No. 23/1, Part 2, Ahmedabad-Mehsana Highway, Laxmipura - Nandasana-GUJARAT INDIA Phone- 8460848087 FAX : 2764-267036/37 Pincode : 382705 Email : domestic@com-fit.com
14	145-45000-A	INSTRUMENT FITTINGS	Fluid Controls Pvt. Ltd.	Sophie Y. Moochhala/Mayur Rajput J.V.PATEL, I.T.I CMPD, B.MADHUKAR MARG, ELPHINSTONE ROADSTN.(WR), MUMBAI Phone- (022) 4338000 Pincode : 400013 Email : sales@fluidcontrols.com	Works-1->Mr. Tansen Choudhari/Mr. Mahesh Darekar Shed No.8, Lonavla Indl.Co-op.Estate Ltd,Nagargaon, -Lonavla-MAHARASHTRA INDIA Phone- 9823951347 FAX : (02114) 271132 Pincode : 410 401 Email : factory@hyd-air.com
15	145-45000-A	INSTRUMENT FITTINGS	FLUIDFIT ENGINEERS PVT. LTD.	Mr. Abbas Bhola Potia Building No. 2, Office No. 3,292, Bellasis Road,Mumbai Central (East) Mumbai Phone- 9920044113 Pincode : 400008 Email : ab@fluidfitengg.com	Works-1->Mr. Abbas Bhola Unit No. 16, Supreme Industrial Estate,Kaman Bhiwandi Road,Devdal, -Vasai East-MAHARASHTRA India Phone- 9920044113 FAX : 07303178243 Pincode : 401208 Email : ab@fluidfitengg.com
16	145-45000-A	INSTRUMENT FITTINGS	HP VALVES & FITTINGS INDIA PVT. LTD.	S. Harichandran/P.S. Pandi B-11, Mugappair Industrial Estate, CHENNAI Phone- 044 26252537 Pincode : 600037 Email : sales@hvalvesindia.com	Works-1->S. Harichandran/ P.S. Pandi B-11, Mugappair Industrial Estate, -CHENNAI-TAMIL NADU INDIA Phone- 044-25252537 FAX : 044-26252538 Pincode : 600037 Email : sales@hvalvesindia.com
17	145-45000-A	INSTRUMENT FITTINGS	PANAM ENGINEERS	Mr. Santosh Shukla 203, Jaisingh Business,Parsiwada, Sahar road,Andheri(East), Mumbai, Phone- 9892179529, Pincode : 400099, Email : santosh@panamengineers.com	Works-1->Mr. Santosh Shukla Others R-628,TTC Industrial Area, MIDC Rabale, -Navi Mumbai-MAHARASHTRA India Phone- 9821350761, FAX : 022-27695559, Pincode : 400701, Email : sales@panamengineers.com
18	145-45000-A	INSTRUMENT FITTINGS	Perfect Instrumentation Control (India) Pvt. Ltd.	MD Hussain Shaikh/Shahanawaz Khan Gala No. 168, Loheki Chwal,216/ 218, Maulana Azad Rd. Nagpada Junction Mumbai Phone- 91-9324383121 Pincode : 400008 Email : shahanawaz.khan@perfectinstrumentation.com	Works-1->Shahanawaz Khan Vishweshwar Ind. Premises Co-op Soc. Ltd,F-18/19, Pradhikaran,Bhosadi MIDC -PUNE-MAHARASHTRA INDIA Phone- 020-30694134 FAX : 022-23013010 Pincode : 411026 Email : shahanawaz.khan@perfectinstrumentation.com
19	145-45000-A	INSTRUMENT FITTINGS	PRECISION ENGINEERING INDUSTRIES	K. SITARAM/ K. SRINIVAS 7,SIDHAPURA INDUSTRIAL ESTATE S.V. ROAD,GOREGAON(W) MUMBAI Phone- 022 42631700 Pincode : 400 062 Email : neiks@vsnl.com	Works-1->ALEX BAPTIST/ K. SRINIVAS 7. SIDHAPURA INDUSTRIAL ESTATE,SV ROAD, GOREGAON(WEST) -MUMBAI-MAHARASHTRA INDIA Phone- 022-42631700 FAX : 022-40035259 Pincode : 400 062 Email : srinivas@precision-engg.com

20	145-45000-A	INSTRUMENT FITTINGS	VIKAS INDUSTRIAL PRODUCTS	S.R.SINGH/NAVEEN SINGH B - 2, SECTOR - 6, NOIDA Phone- +91-9810122070 Pincode : 201301 Email : naveensinh@vsnl.com	Works-1->S.R.SINGH/ NAVEEN SINGH B - 2, SECTOR - 6, -NOIDA-UTTAR PRADESH INDIA Phone- 0120-4352940 FAX : 0120-4352940 Pincode : 201301 Email : naveensinh@vsnl.com
21	145-25000-A	JUNCTION BOX	AJMERA INDUSTRIAL & ENGINEERING WORKS	JIGNESH MAHENDRA AJMERA DENA BANK BLDG.,SHREE NAGESH INDL. ESTATE,STATION ROAD, MUMBAI Phone-022 67973578 Pincode : 400 088 Email : ajmera@ajmera.net, jmajmera@yahoo.com	Works-1->JIGNESH MAHENDRA AJMERA DENA BANK BLDG., SHREE NAGESH INDL. ESTATE,STATION ROAD, -MUMBAI-MAHARASHTRA INDIA Phone- 022 67973578 FAX : Pincode : 400 088 Email : ajmera@ajmera.net
22	145-25000-A	JUNCTION BOX	FLEXPRO ELECTRICALS PVT. LTD.	Mr. Dineshbhai Zaveri C-1/ 278,37, GIDC, Kabilpore, Navsari Phone- 02637-265140,265003 Pincode : 396424 Email : flexpro@flexproindia.com	Works-1->Mr. Dineshbhai Zaveri CEO C-1/ 278,37, GIDC, Kabilpore, -Navsari-GUJARAT INDIA Phone- 02637-265140,265003 FAX : 02637-265308 Pincode : 396424 Email : flexpro@flexproindia.com
23	145-25000-A	JUNCTION BOX	K.S.INSTRUMENTS PVT.LTD.	S Raghavan No. 72, 3rd Main, 1st Stage Industrial Suburb, Yeshwanthpur Bangalore Phone- 9880385770 Pincode : 560022 Email : sales1@ksinstruments.net	
24	145-25000-A	JUNCTION BOX	Shrenik & Company,	Mr. Mitesh Shah/Mr. Pulin Shah 39 A/3 ,Panchratna Industrial Estate, Sarkhej-Bavla Road Ahmedabad Phone-9825024921 Pincode : 382213 Email : sales@mustroon.com, pulin@sumin.com	Works-1->Mr.Pulin Shah/ Mr. Kaloesh Parmar 39 A/3 ,Panchratna Industrial Est,Sarkhej-Bavla Road, Changodhar -Ahmedabad-GUJARAT INDIA Phone- 98250 80339 1 FAX : 079-26932424 Pincode : 382213 Email : sales@sumin.com
25	145-25000-A	JUNCTION BOX	SUCHITRA INDUSTRIES	NO-2,OPP-27 AECS LAYOUT 2ND STG REJAMAHALVILAS EXTN 2ND STG BANGALORE Phone- Pincode : Email : suchitra.industriesblr@gmail.com	Works-1->B. Srinivas Suchitra Industries, Opp No 53, Muneshwara Black Devinagar, Lottagal hal -BANGALORE-KARNATAKA INDIA Phone- 080-23511247 FAX : Pincode : 560094 Email : suchitra_industries@vahoo.com
26	145-08000-A	PRESSURE GAUGE/ DIFF.PRESSURE GAUGE	A.N. INSTRUMENTS PVT. LTD.	MARKETING DIVISION, 5th FLOOR, 59-B, CHOWRINGHEE ROAD, KOLKATA Phone-24757784,22472509 Pincode : 700020 Email : anidel@ahnl.net.in	Works-1->Mr. Gautam Mukherjee Kusumba,Sonarpur Station Road,P.O. -Narendrapur, -Kolkata-WEST BENGAL INDIA Phone- 9836878855 FAX : 033-24342748 Pincode : 700103 Email : nkm_ani@hotmail.com
27	145-08000-A	PRESSURE GAUGE/ DIFF.PRESSURE GAUGE	Baumer Technologies India Pvt. Ltd.	Mr. Shyam Warilani/Mr. V Suresh Babu 36, DAMJI SHAMJI INDUSTRIAL COMPLEX, OFF.-MAHAKALI CAVES ROAD, ANDHERI(E) MUMBAI Phone- +91 99589 25151 Pincode : 400093 Email : sales.in@baumer.com	Works-1->Mr. Shyam Warilani/Mr. V Suresh Babu Plot No 34 A GIDC A Phase 1, -VAPI-GUJARAT INDIA Phone- +91 11 4161 7111 FAX : 022 2687 3613 Pincode : 396 195 Email : pbajaj@baumer.com
28	145-08000-A	PRESSURE GAUGE/ DIFF.PRESSURE GAUGE	BOSE PANDA INSTRUMENTS PVT.LTD.	Mr. Partha Bose 44, Saheed Hemanta Kumar Bose, Sarani, Kolkata Phone- +91 33 2548 7220 Pincode : 700074 Email : parthabosebpi@gmail.com; hosenanda@vsnl.net	Works-1->Mr. Partha Bose 44, Saheed Hemanta Kumar Bose,Sarani, -Kolkata-WEST BENGAL India Phone- +91 33 2548 7220 FAX : +91 33 2548 0429, Pincode : 700074 Email : parthabosebpi@gmail.com bosepanda@vsnl.net
29	145-08000-A	PRESSURE GAUGE/ DIFF.PRESSURE GAUGE	FORBES MARSHALL (HYD) LTD.	MR SAILESH PATALAY/MR. M K SRINIVASAN PLOT NO.A-19/2, & T-4/2, IDA, NACHARAM, HYDERABAD Phone-9849913704 Pincode : 500 076 Email : mksrinivasan@forbesmarshall.com	Works-1->MR G.SRINIVASAN/MR ANUJ MALPANI PLOT NO:A-19/2 & T-4/2,I.DA. NACHARAM , -HYDERABAD-TELANGANA INDIA Phone- 09866550762 FAX : 040 27152193 Pincode : 560076 Email : nsrinivasan@forbesmarshall.com
30	145-08000-A	PRESSURE GAUGE/ DIFF.PRESSURE GAUGE	GAUGE BOURDON INDIA PVT. LTD.	194/195, Gopi Tank Road, Off Pandurang Naik Marg, Mahim Mumbai, Phone- 011-41607463, Pincode : 400016, Email : gicdelhi@general-gauges.com,	Works-1->Gauge Bourdon India Pvt. Ltd., Plot No-4, 5, 6,Jawahar Co-operative Industrial Estate, -Kalamboli Taluka Panvel-MAHARASHTRA India Phone- 022-27421095, FAX : 022-27421901, Pincode : 410209, Email : info@general-gauges.com
31	145-08000-A	PRESSURE GAUGE/ DIFF.PRESSURE GAUGE	H.GURU INDUSTRIES	Mr. G. D. Hazra/Mr. P. K. Mitra 10 B, HO-CHI-MINH SARANI, KOLKATA Phone-033 2282 2463 / 1637 Pincode : 700071 Email : mguru@vsnl.net	Works-1->NA NA -- Phone- FAX : Pincode : Email :
32	145-08000-A	PRESSURE GAUGE/ DIFF.PRESSURE GAUGE	H.GURU INSTRUMENTS (SOUTH INDIA) P. LTD	32,INDUSTRIAL SUBURB YESWANTHAPUR BANGALORE Phone- 080-23370300, Pincode : 560022 Email : info@hgurusouth.com	Works-1->Shikha Hazra/ Shyamal Hazra 32, Industrial Suburb,Yeshwanthpur -BANGALORE-KARNATAKA INDIA Phone- 080-23370300 FAX : 080-23379890 Pincode : 560022 Email : shikhabazra@hgurusouth.com
33	145-08000-A	PRESSURE GAUGE/ DIFF.PRESSURE GAUGE	Nesstech Instruments Private Limited	26/2, G Type, Global Industrial Park Near Nahuli Railway Crossing, Valvada Vapi Phone- 9920576002 Pincode : 396105 Email : sales@nesstech.co.in	Works-1-> Others 26/2, G Type, Global Ind. Park Near Nahuli Railway Crossing, -Vapi-GUJARAT INDIA Phone- 9920576002 FAX : Pincode : 396105 Email : sales@nesstech.co.in bkanadia@nesstech.co.in
34	145-08000-A	PRESSURE GAUGE/ DIFF.PRESSURE GAUGE	PRECISION MASS PRODUCTS PVT. LTD.	Mr. Nishit Patel/Mr. Anuj Verma Plot No.2306, Phase II, GIDC Chhatral Kalol Phone- 9999464663 Pincode : 382729 Email : sales@precisionmass.com	Works-1->Mr. Hitesh Parmar/Mr. Hitesh Parmar Plot No.2306, Phase II, GIDC Chhatral, -Kalol-GUJARAT INDIA Phone- 9327359227 FAX : 02764-233440 Pincode : 382729 Email : hitesh.parmar@ashcroffindia.com
35	145-08000-A	PRESSURE GAUGE/ DIFF.PRESSURE GAUGE	SCIENTIFIC DEVICES (BOMBAY) PVT LTD,	Office no. 53, Shree Manoshi Complex, Plot No. 5 & 6, Sec-3, Ghansoli (East), Navi Mumbai, Phone- 9892230623, Pincode : 400 701, Email : sdbpl@vsnl.com	Works-1->Scientific Center, Others By-Pass Junction,Near Kalsekar College kausa, mumbra,Thane -Mumbai-MAHARASHTRA INDIA Phone- 022-25491409,9892230623 FAX : Pincode : 400612 Email : sdbpl@vsnl.com
36	145-16000-A	SIGHT FLOW INDICATORS	B.K.EQUIPMENTS PVT.LTD.	T. BALAKRISHNAN/S.VENKATESH 217 , ARCOT ROAD PORUR , CHENNAI Phone-9444057761 Pincode : 600116 Email : bkenuin@gmail.com	Works-1->V.KARUNANIDHI/P.BABU 217 , ARCOT ROAD,PORUR , -CHENNAI-TAMIL NADU INDIA Phone- 9444131187 FAX : 044-24766852 Pincode : 600116 Email : bkenuin@gmail.com
37	145-16000-A	SIGHT FLOW INDICATORS	BLISS ANAND PVT. LTD.	Mr. Vikas Anand/ Mr.RGRajan 92B & 93 B , IMT MANESAR Gurgaon Phone- 0124-4366000 TO 9 Pincode : 122001 Email : sales@blissanand.com	Works-1->Mr. Bharat Kumar/ Mr. Sasi Kumar Plot No. 240, Sector-3, HSIIDC, Bawal -Rewari-HARYANA INDIA Phone-0124-4366000 TO 9 FAX : 0124-2290884 Pincode : 123501 Email : bharat@blissanand.com
38	145-16000-A	SIGHT FLOW INDICATORS	INSTRUMENTATION ENGINEERS PVT LTD	SH.N.V.RAM GOPAL/MS. N.NIHARIKA PLOTS 1,2,3, PHASE-III, IDA, JEEDIMETLA HYDERABAD Phone- 9848407365 Pincode : 500055 Email : iedelhi@ieflowmeters.com	Works-1->MR. A.V.MURTHY/MR. K.T. RAVISANKER PLOTS 1,2,3, PHASE-III,IDA, JEEDIMETLA -HYDERABAD-TELANGANA INDIA Phone- 9885107312 FAX : 040-23096401 Pincode : 500055 Email : sales@ieflowmeters.com
39	145-16000-A	SIGHT FLOW INDICATORS	SCIENTIFIC DEVICES (BOMBAY) PVT LTD,	Office no. 53, Shree Manoshi Complex, Plot No. 5 & 6, Sec-3, Ghansoli (East), Navi Mumbai, Phone- 9892230623, Pincode : 400 701, Email : sdbpl@vsnl.com	
40	145-16000-A	SIGHT FLOW INDICATORS	SIGMA INSTRUMENTS CO.	Gopal Kannan/R Gopinath 201, ANANDRAJ INDUSTRIAL ESTATE, OFF.LBS MARG, SONAPUR LANE, BHANDUP (W) MUMBAI Phone- +919821038162 Pincode : 400078 Email : sales@sigmainstruments.co.in	Works-1->R Gopinath 27 Nahur Udyog Industrial Premises,M.M.Malviya Road, Mulund(-MUMBAI-MAHARASHTRA INDIA Phone- +912225918567 FAX : +912225918566 Pincode : 400080 Email : sales@sigmainstruments.co.in
41	145-16000-A	SIGHT FLOW INDICATORS	V. AUTOMAT & INSTRUMENTS (P) LTD.	Mr. R. K. BASSI/Mr. PRAVEEN KUMAR F-61, OKHLA INDL.AREA, PH-1 NEW DELHI Phone- 9810005826 Pincode : 110 020 Email : sales@vautomat.com	Works-1->Mr. BHAGWAN SINGH/ Mr. NANDAN SINGH F-34, OKHLA INDL.AREA,PHASE-I -NEW DELHI-DELHI INDIA Phone- 011-47627200 Extn. 3 FAX : 011- 26819440 Pincode : 110 020 Email : production@vautomat.com

42	145-13000-A	TEMP. ELEMENT	Baumer Technologies India Pvt. Ltd.	Mr. Shyam Warilani/Mr. V Suresh Babu 36, DAMJI SHAMJI INDUSTRIAL COMPLEX, OFF.-MAHAKALI CAVES ROAD, ANDHERI(E) MUMBAI Phone- +91 99589 25151 Pincode : 400093 Email : sales.in@baumer.com	Works-1->Mr. Shyam Warilani/Mr. V Suresh Babu Plot No 34 À GIDC À Phase 1, -VAPI-GUJARAT INDIA Phone- +91 11 4161 7111 FAX : 022 2687 3613 Pincode : 396 195 Email : pbajaj@baumer.com
43	145-13000-A	TEMP. ELEMENT	DETRIVE INSTRUMENTATION & ELECTRONICS LTD.	320, TV INDUSTRIAL ESTATE, OFF.DR.A.BESANT ROAD, BEHIND GLAXO, WORLI, MUMBAI Phone- 24934125,24938403 Pincode : 400025 Email : trivtech@vsnl.com	Works-1->Mr. A.D.Solomon J-14, MIDC, TARAPORE, BOISER STN., -THANE-MAHARASHTRA India Phone- FAX : Pincode : Email : trivtech@vsnl.com
44	145-13000-A	TEMP. ELEMENT	GAUGE BOURDON INDIA PVT. LTD.	194/195, Gopi Tank Road, Off Pandurang Naik Marg, Mahim Mumbai, Phone- 011-41607463, Pincode : 400016, Email : gicdelhi@general-gauges.com,	Works-1->Gauge Bourdon India Pvt. Ltd., Plot No-4, 5, 6,Jawahar Co-operative Industrial Estate, -Kalamboli Taluka Panvel-MAHARASHTRA India Phone- 022-27421095, FAX : 022-27421901, Pincode : 410209, Email : info@general-gauges.com
45	145-13000-A	TEMP. ELEMENT	GOA INSTRUMENTS INDUSTRIES PVT.LTD.,	D2/5, Mapusa Industrial Estate, Mapusa, Goa, Phone- 09326054551, Pincode : 403507, Email : sumukh@noainstruments.com	Works-1->Mr. S.G. Dixit D2/5, Mapusa Industrial Estate, -Mapusa-GOA INDIA Phone- 09326054551 FAX : 0832-2262331 Pincode : 403 507 Email : sumukh@noainstruments.com
46	145-13000-A	TEMP. ELEMENT	Nesstech Instruments Private Limited	26/2, G Type, Global Industrial Park Near Nahuli Railway Crossing, Valvada Vapi Phone- 9920576002 Pincode : 396105 Email : sales@nesstech.co.in	Works-1-> Others 26/2, G Type, Global Ind. Park Near Nahuli Railway Crossing, -Vapi-GUJARAT INDIA Phone- 9920576002 FAX : Pincode : 396105 Email : sales@nesstech.co.in hkanadia@nesstech.co.in
47	145-13000-A	TEMP. ELEMENT	PYRO ELECTRIC INSTRUMENTS GOA PVT.LTD.	M. D. BICHU/R. M. BICHU G.B, HILL CROWN APARTMENTS, COLLEGE ROAD, MAPUSA Phone- 9326114601 Pincode : 403507 Email : priyanka.marketing@pyro-electric.in	Works-1->A A KULKARNI/ VINOD C G PLOT NO. 71,BICHOLIM INDUSTRIAL ESTATE -BICHOLIM-GOA INDIA Phone- 9326114409 FAX : 91 832 2363381 Pincode : 403529 Email : pyroworks@pyro-electric.in
48	145-13000-A	TEMP. ELEMENT	SCIENTIFIC DEVICES (BOMBAY) PVT LTD,	Office no. 53, Shree Manoshi Complex, Plot No. 5 & 6, Sec-3, Ghansoli (East), Navi Mumbai, Phone- 9892230623, Pincode : 400 701, Email : sdbpl@vsnl.com	Works-1->Scientific Center, Others By-Pass Junction,Near Kalsekar College kausa, mumbra,Thane -Mumbai-MAHARASHTRA INDIA Phone- 022-25491409,9892230623 FAX : Pincode : 400612 Email : sdbpl@vsnl.com
49	145-13000-A	TEMP. ELEMENT	Tempsens Instrument (I) Pvt Ltd	MR. V.P.RATHI/MR. HEMANT RATHI B-188A ROAD NO.5 , M.I.A UDAIPIUR Phone- 09352420069 Pincode : 313003 Email : info@tempsens.com	Works-1->Mr. S.D Deval B-188A ROAD NO.5 ,M.I.A -UDAIPIUR-RAJASTHAN INDIA Phone- 9352501530 FAX : 0294-3057750 Pincode : 313003 Email : deval@tempsens.com
50	145-13000-A	TEMP. ELEMENT	Thermal Instrument India Pvt. Ltd.	Mr. Raghavendra M. Kulkarni 194/195, Gopi Tank Road Behind Citylight Cinema,Mahim Mumbai Phone- 09322664709 Pincode : 400016 Email : ramk@giconindia.com	Works-1->Mr. Raghavendra M. Kulkarni Survey No. 250A/B, Post-Mangoan,Tal.- Kudal, Dist.- Sindhudurg, --MAHARASHTRA India Phone- 09322664709 FAX : 022-24455026 Pincode : 416519 Email : ramk@giconindia.com
51	145-13000-A	TEMP. ELEMENT	TOSHIWAL INDUSTRIES PVT. LTD.,	Industrial Estate, Makhapura, Ajmer, Phone- 9352009000, Pincode : 305002, Email : info@tipl.com,	Works-1-> Khasra No.: 218-230& 235, Industrial Estate,Makhapura, -Ajmer-RAJASTHAN India Phone- 9887865856, FAX : 0145-2695174, Pincode : 305002, Email : raieev.quota@tipl.com
52	145-10000-A	TEMPERATURE GAUGE	A.N. INSTRUMENTS PVT. LTD.	MARKETING DIVISION, 5th FLOOR, 59-B, CHOWRINGHEE ROAD, KOLKATA Phone- 24757784,22472509 Pincode : 700020 Email : anidel@bol.net.in	Works-1->Mr. Gautam Mukherjee Kusumba,Sonarpur Station Road,P.O. -Narendrapur, -Kolkata-WEST BENGAL INDIA Phone- 9836878855 FAX : 033-24342748 Pincode : 700103 Email : gkm_ani@hotmail.com
53	145-10000-A	TEMPERATURE GAUGE	Baumer Technologies India Pvt. Ltd.	Mr. Shyam Warilani/Mr. V Suresh Babu 36, DAMJI SHAMJI INDUSTRIAL COMPLEX, OFF.-MAHAKALI CAVES ROAD, ANDHERI(E) MUMBAI Phone- +91 99589 25151 Pincode : 400093 Email : sales.in@baumer.com	Works-1->Mr. Shyam Warilani/Mr. V Suresh Babu Plot No 34 À GIDC À Phase 1, -VAPI-GUJARAT INDIA Phone- +91 11 4161 7111 FAX : 022 2687 3613 Pincode : 396 195 Email : pbajaj@baumer.com
54	145-10000-A	TEMPERATURE GAUGE	FORBES MARSHALL (HYD) LTD.	MR SAILESH PATALAY/MR. M K SRINIVASAN PLOT NO.A-19/2, & T-4/2, IDA, NACHARAM, HYDERABAD Phone- 9849913704 Pincode : 500 076 Email : mksrinivasan@forbesmarshall.com	Works-1->MR G.SRINIVASAN/MR ANUJ MALPANI PLOT NO:A-19/2 & T-4/2,I.DA. NACHARAM , -HYDERABAD-TELANGANA INDIA Phone- 09866550762 FAX : 040 27152193 Pincode : 560076 Email : nsrinivasan@forbesmarshall.com
55	145-10000-A	TEMPERATURE GAUGE	GAUGE BOURDON INDIA PVT. LTD.	194/195, Gopi Tank Road, Off Pandurang Naik Marg, Mahim Mumbai, Phone- 011-41607463, Pincode : 400016, Email : gicdelhi@general-gauges.com,	Works-1->Gauge Bourdon India Pvt. Ltd., Plot No-4, 5, 6,Jawahar Co-operative Industrial Estate, -Kalamboli Taluka Panvel-MAHARASHTRA India Phone- 022-27421095, FAX : 022-27421901, Pincode : 410209, Email : info@general-gauges.com
56	145-10000-A	TEMPERATURE GAUGE	GOA INSTRUMENTS INDUSTRIES PVT.LTD.,	D2/5, Mapusa Industrial Estate, Mapusa, Goa, Phone- 09326054551, Pincode : 403507, Email : sumukh@noainstruments.com	Works-1->Mr. S.G. Dixit D2/5, Mapusa Industrial Estate, -Mapusa-GOA INDIA Phone- 09326054551 FAX : 0832-2262331 Pincode : 403 507 Email : sumukh@noainstruments.com
57	145-10000-A	TEMPERATURE GAUGE	GOA THERMOSTATIC INSTRUMENTS PVT.LTD.	FLAT -B , GF, HILL CROWN APTS., COLLEGE ROAD, MAPUSA Phone- Pincode : 403525 Email : gtilworks@pyro-electric.in	Works-1->Mrs Saanvi Naik BICHOLIM, -BICHOLIM-GOA INDIA Phone- 959585152 FAX : Pincode : 403 529 Email : saanvi.naik@thermostatic.in
58	145-10000-A	TEMPERATURE GAUGE	H.GURU INDUSTRIES	Mr. G. D. Hazra/Mr. P. K. Mitra 10 B, HO-CHI-MINH SARANI, KOLKATA Phone- 033 2282 2463 / 1637 Pincode : 700071 Email : mguru@vsnl.net	Works-1->NA NA -- Phone- FAX : Pincode : Email :
59	145-10000-A	TEMPERATURE GAUGE	H.GURU INSTRUMENTS (SOUTH INDIA) P. LTD	32,INDUSTRIAL SUBURB YESWANTHAPUR BANGALORE Phone- 080-23370300, Pincode : 560022 Email : info@hgurusouth.com	Works-1->Shikha Hazra/ Shyamal Hazra 32, Industrial Suburb,Yeshwanthpur -BANGALORE-KARNATAKA INDIA Phone- 080-23370300 FAX : 080-23379890 Pincode : 560022 Email : shikhabazra@hgurusouth.com
60	145-10000-A	TEMPERATURE GAUGE	PRECISION MASS PRODUCTS PVT. LTD.	Mr. Nishit Patel/Mr. Anuj Verma Plot No.2306, Phase II, GIDC Chhatral Kalol Phone- 9999464663 Pincode : 382729 Email : sales@precisionmass.com	Works-1->Mr. Hitesh Parmar/Mr. Hitesh Parmar Plot No.2306, Phase II, GIDC Chhatral, -Kalol-GUJARAT INDIA Phone- 9327359227 FAX : 02764-233440 Pincode : 382729 Email : hitesh.parmar@ashcroffindia.com
61	145-14000-A	TRANSMITTERS	ABB INDIA LIMITED	MR. RAJIV GOVIL 14, MATHURA ROAD, FARIDABAD Phone- 09971085678 Pincode : 121003 Email : vipin.swami@in.abb.com	
62	145-14000-A	TRANSMITTERS	EMERSON PROCESS MANAGEMENT (INDIA) PVT.LTD.	Mr. Amit Paithankar/Vikram Raj Singh 206-210,BALARAMA BUILDING 2ND FLR. BANDRA EAST MUMBAI Phone- 9619121500 Pincode : 400051 Email : vikramraj.singh@emerson.com	Works-1->Kalpesh Chandan/Hrishikesh Aghor Plot No. A 145/4 TTC IND AREA,MIDC, PAWANE, -NAVI MUMBAI-MAHARASHTRA INDIA Phone- 9619688001 FAX : 022-66736000 Pincode : 400 705 Email : kalpesh.chandan@emerson.com
63	145-14000-A	TRANSMITTERS	Endress + Hauser (India) Pvt. Ltd.,	Mr. Prakash Vaghela 215-216, DLF Tower 'A', Jasola District Centre, New Delhi, Phone- 9717593001, Pincode : 110025, Email : prakash.vaghela@in.endress.com,	Works-1-> M-171 to 173, MIDC, Waluj, -Aurangabad-MAHARASHTRA India Phone- 9881000474, FAX : 0240-2555179, Pincode : 431136, Email : Narendra.Kulkarni@wetzler.endress.com

64	145-14000-A	TRANSMITTERS	Honeywell Automation India Limited	Mr. Ritwij Kulkarni 917, INTERNATIONAL TRADE TOWER, NEHRU PLACE, NEW DELHI Phone- 9890200584 Pincod : 110019 Email : raiesh.chaudhary@honeywell.com	Works-1->Mr.Kedar Tillu 53, 54, 56 & 57,Hadapsar Industrial Estate -PUNE-MAHARASHTRA INDIA Phone-9665034625 FAX : 020 66039905 Pincod : 411013 Email : kedartillu@honeywell.com
65	145-14000-A	TRANSMITTERS	Moore Industries International Inc.	Leonard.W. Moore/ Matt Moren 16650 Schoenborn St. North Hills Phone- +1 818 830 5548 Pincod : 91343 Email : mmoren@mininet.com	Works-1->Matt Moren/Gina Cruz 16650 Schoenborn St., North Hills -CALIFORNIA- USA Phone- +1 818 894 7111, ext FAX : +1 818 830 5588 Pincod : 91343 Email : gcruz@mininet.com
66	145-14000-A	TRANSMITTERS	NIVO CONTROLS PVT. LTD.	Mr. Praveen Toshniwal 104-115, Electronic Complex, Indore Phone- 0731-4081305 Pincod : 452010 Email : sales@nivocontrols.com	Works-1->Mr. S L Sadani Others 104 - 115,Electronic Complex -Indore-MADHYA PRADESH INDIA Phone- 0731-4081307 FAX : Pincod : 452010 Email : sales@nivocontrols.com ; sadanis@nivocontrols.com
67	145-14000-A	TRANSMITTERS	PANAM ENGINEERS	Mr. Santosh Shukla 203, Jaisingh Business,Parsiwada, Sahar road,Andheri(East), Mumbai, Phone-9892179529, Pincod : 400099, Email : santosh@panamengineers.com	Works-1->Mr. Santosh Shukla Others R-628,TTC Industrial Area, MIDC Rabale, -Navi Mumbai-MAHARASHTRA INDIA Phone- 9821350761, FAX : 022-27695559, Pincod : 400701, Email : sales@panamengineers.com
68	145-14000-A	TRANSMITTERS	Pune Techrol Pvt. Ltd.	N.P.Khatan/Sudhakar Badiger 5-18, MIDC Bhosari, Pune Phone- 9850560042 Pincod : 411 026 Email : ho@punetechrol.com	
69	145-14000-A	TRANSMITTERS	SBEM PVT. LTD.	MR.N.K. BEDARKAR/MR. VISHWANATH KARANDIK 39, ELECTRONIC CO.OP. ESTATE, PUNE SATARA ROAD PUNE, Phone- 912041030100 Pincod : 411009 Email : pnwdelbi@sbem.co.in	Works-1->MR. MOHAN PADWAL 691/A/2,BIBWEWADI INDL ESTATE -PUNE-MAHARASHTRA INDIA Phone- 918600042374 FAX : 912024215670 Pincod : 411037 Email : wm@sbem.co.in
70	145-14000-A	TRANSMITTERS	SIEMENS LIMITED	Dr. Armin Bruck/Sandeep Mathur 130, Pandurang Budhkar Marg Worli Mumbai Phone- 0124 383 7377 Pincod : 400018 Email : ankit.varshney@siemens.com	Works-1->Ankit Varshney Kalwa Works, Thane-Belapur Road, Thane, -MUMBAI-MAHARASHTRA INDIA Phone- FAX : Pincod : 400708 Email :
71	145-14000-A	TRANSMITTERS	SMART INSTRUMENTS LTD, BRAZIL	Agents: Digital Electronic Ltd. 74/11 'C' Cross Road MIDC Andheri (East) MUMBAI Phone- 28208477 Pincod : 400093 Email : corp@delbby.rpgms.ems.vsnl.net.in	
72	145-14000-A	TRANSMITTERS	TOSHWAL INDUSTRIES PVT. LTD.,	Industrial Estate, Makhupura, Ajmer, Phone- 9352009000, Pincod : 305002, Email : info@tipl.com ,	Works-1-> Khasra No.: 218-230& 235, Industrial Estate,Makhupura, -Ajmer-RAJASTHAN INDIA Phone-9887865856, FAX : 0145-2695174, Pincod : 305002, Email : rajeev.nunta@tipl.com
73	145-14000-A	TRANSMITTERS	V. AUTOMAT & INSTRUMENTS (P) LTD.	Mr. R. K. BASSI/Mr. PRAVEEN KUMAR F-61, OKHLA INDL.AREA, PH-1 NEW DELHI Phone- 9810005826 Pincod : 110 020 Email : sales@vautomat.com	Works-1->Mr. BHAGWAN SINGH/ Mr. NANDAN SINGH F-61, OKHLA INDL.AREA,PHASE-I -NEW DELHI-DELHI INDIA Phone- 011-47627200 Extn. 3 FAX : 011- 26819440 Pincod : 110 020 Email : production@vautomat.com
74	145-14000-A	TRANSMITTERS	YOKOGAWA INDIA LIMITED,	PLOT NO.96, ELECTRONICS CITY COMPLEX, HOSUR ROAD, BANGALORE, Phone-080-41586000, Pincod : Email : udav.shankar@in.yokogawa.com	Works-1-> PLOT NO.96, ELECTRONICS CITY COMPLEX, HOSUR ROAD, -BANGALORE-KARNATAKA INDIA Phone- 080-41586000, FAX : 080-28521442, Pincod : Email : udav.shankar@in.yokogawa.com

KKS NUMBERING PHILOSOPHY

**KKS NUMBERING PHILOSOPHY**

For identifying (tagging) an instrument / equipment in Power plant KKS numbering scheme is used. The purpose is to assign a unique number to every equipment in the power plant. For C&I equipment unique number are to be provided up to the signal level so that a unique number Input / Output exist in DCS for every signal.

Normally KKS number is a 10 digit alpha-numeric code and is typically split into the following:

X	X	X	A	A	Y	Y	B	B	B
---	---	---	---	---	---	---	---	---	---

First three digits indicate the Sub-System. The Code for the major system are given as per **Annexure-1**.

Fourth and Fifth digits are the **Numerical Keys at System Code Level** and used to distinguish between main systems having same Alpha Codes.

Sixth and Seventh digits are the **Equipment / Apparatus / Measuring Circuit Code**. The code of various Equipment / Apparatus / Measuring Circuit is shown in **Annexure-2**

Eight, Nine and tenth digits are the **Numerical Keys at Equipment / Apparatus / Measuring Circuit Code** and used to distinguish between various instruments in the same sub-group. Numerical keys at System / Equipment / Apparatus / Measuring Circuit is shown in **Annexure-3**.

**

KKS TAGS ARE PROVIDED IN THE P&ID FURNISHED BY VENDOR. HOWEVER, IF THE KKS NUMBER OF EQUIPMENT/INSTRUMENTS CHANGES, THE SAME SHALL BE FINALIZED DURING DETAILED ENGINEERING.

**ANNEXURE-1****List of System / Sub-System Codes used in Power Plant:**

- 1) Refer the P&ID sheets.

ANNEXURE-2**Standard Equipment Codes:**

AA	Valves including drives, also hand operated
AB	Seclusions, Lock, Gates, Doors
AC	Heat Exchanger
AE	Turning, Driving, Lifting equipment
AF	Continuous conveyors, Feeders
AG	Generator Units
AH	Heating and Cooling Units
AK	Pressing and Packaging equipment
AM	Mixer, Stirrer
AN	Blower, Air Pumps / Fans, Compressor Units
AP	Pump Units
AT	Purification, Drying, Filter
AV	Combustion Equipment e.g. grates

Standard Apparatus Codes:

BB	Vessels and Tank
BF	Foundation
BG	Boiler Heating Surfaces
BN	Injector, Ejector
BP	Flow and throughput limitation equipment (Orifice)
BQ	Holders, Carrying Equipment, Support
BR	Piping, Ducts, Chutes, Compensator
BS	Sound Absorber
BU	Insulations, Sheatings

Standard Measuring Circuits Codes:

CD	Density
CE	Electrical Quantities
CF	Flow, throughput
CG	Distance, Length, Position
CK	Time
CL	Level



CM	Humidity
CQ	Analysis (SWAS)
CS	Speed, Velocity, Frequency
CT	Temperature
CY	Vibration, Expansion

ANNEXURE-3

Numerical Keys

A) Numerical Keys at System Code Level

- i) Use 10, 20, 30... To distinguish between main systems having same Alpha Codes. Examples:
 - a) Main Steam (Left) and Main Steam (Right)
 - b) BFP – A/B/C
 - c) ID Fan – A/B, FD Fan A/B, AH – A/B
- ii) For branch off from main system path having code say 10, keep the same alpha code and use 11, 12, 13 etc. Similarly for other branch off from main system path having code say 20, keep the same alpha code and use 21, 22, 23 etc and shall carry on further in the same way.
- iii) If the branch off from main system / sub system path is used for some other system, where different alpha codes can be applied, then in that case the said branch line will be designated by the alpha codes of the system to which it is providing the input.

B) Numerical keys at Equipment Code level:

There are three numerical keys available for each type of equipment code. Following has been agreed upon considering present practice, better flexibility and ease in sorting.

i) Valves and Dampers --- Equipment Code – AA

		<u>N1</u>	<u>N2 N3</u>
Motorised (<i>on/off duty</i>)	-	0	01 to 50
Motorised (<i>inching duty</i>)	-	0	51 to 99
Pneumatic (Control)	-	1	01 to 50
Motorised (<i>thyrestor Control</i>)	-	1	51 to 99
Sol. Operated (Open / Close duty (Valves, NRVs, Gate)	-	2	01 to 99
Hydraulic	-	3	01 to 99



DOCUMENT TITLE

KKS NUMBERING PHILOSOPHY

NRV (Without actuation)	-	4	01 to 99
Manual	-	5	01 to 99
Manual	-	6	01 to 99
Relief & Safety Valves	-	7	01 to 99
Reserve	-	8	01 to 99
Reserve	-	9	01 to 99

ii) **Field Instruments**

Field Transmitters & Analog Signals	-	0	01 to 99
Field Switches & Binary Signals	-	1	00 to 99
PG Test Point	-	4	00 to 99
Gauges	-	5	00 to 99
Automatic Turbine Tester (ATT)-HWR	-	2	00 to 99
(Reserved for protection Signals used by Hardwar)			

Example of Numerical Key Usage:

In line with the philosophy adopted for Valves / Dampers /instruments etc. pumps and fans in the main systems (having different system code) can be numbered as AP/N100 and as AP/N101, 102, Where system code is same.



**1x800 MW TANGEDCO NORTH CHENNAI
TPP– (FGD SYSTEM)
HVAC SYSTEM
TECHNICAL SPECIFICATION
(C&I PORTION)**

**SPECIFICATION No: PE-TS-485- (571-13000-
A)-A001 (REV-0)**

SECTION : I

SUB-SECTION : C-5

REV. 00

SECTION: I

SUB-SECTION: C-5

TECHNICAL SPECIFICATION (MATERIAL HANDLING)



**TECHNICAL SPECIFICATION
ELECTRIC HOISTS & CHAIN PULLEY BLOCKS
1X800 MW NORTH CHENNAI FGD.**

Material Handling Equipments



**TECHNICAL SPECIFICATION
ELECTRIC HOISTS & CHAIN PULLEY BLOCKS
1X800 MW NORTH CHENNAI FGD.**

1.0 ELECTRIC HOIST AND MANUAL HOIST (CHAIN PULLEY BLOCK)

Required number of electric hoist / manual hoist of adequate capacity, to meet the erection and maintenance requirements are to be provided for the various areas.

Manual hoists (hand operated) shall be designed to duty class 2 as per IS 3832 and electric wire rope hoist shall be designed as per IS: 3938 (latest).

The stipulations of all statutory codes like Indian Electricity Act, Indian Electricity Rules, Factory Acts, Local Municipality act etc. shall however prevail over the specification requirements, in case any conflict arises between this specification and the statutory codes.

Maintenance tools and tackles shall be as per data sheet attached.

DESIGN CRITERIA

- 1.0.0** Electrically operated wire rope hoists of suitable capacity, lift, and travel length shall be provided for handling of items weighing 2000 kgs. Electric hoists shall be provided for lifts >10m irrespective of the capacity.. The hoist capacity shall be selected considering 25% margin over the weight of heaviest component /equipment to be handled. The hoist parameters (i.e. lift & travel) are subject to change/s, to suit the final layout of the area in which it is intended to be installed.

Chain pulley block (Manual hoist) to be provided for handling items weighing 500kg to 2T.

Capacity of electric and manual (Chain pulley block) hoists shall be decided keeping 25% margin over equipment to be handled.

For hand operated hoists, the hoists shall be suitable for operation from floor level. Hand chain shall be provided for long travel of trolley and the Hoisting mechanism. The operator shall be able to control the movement of the electrical/ manual hoist with the help of floor operated pendant

MINIMUM LIFTING REQUIREMENT

S.N.	AREA DESCRIPTION	QTY (nos)	CAPACITY(T)	TYPE
1	LIST TO BE MENTIONED AS APPLICABLE			
2				
3				

Note:

1. Area, type, capacity mentioned are minimum requirement and shall be finalised during detail engineering without any commercial implication
2. Travel and Lift are layout dependent and shall be finalised during detail engineering without any commercial implication
3. Additional electric/manual hoist required during detail engineering shall be provided as per design criteria given above without any commercial implication.

2.0 SCOPE OF SUPPLIES

Equipment and services to be furnished by the bidder for the ELECTRIC HOIST/ MANUAL HOIST with accessories as per the details given in the technical specification and data sheet A. Any equipment / accessories not specified in the specification but required to make the ELECTRIC HOIST/ MANUAL HOIST complete and efficient operation shall also be under the bidder's scope of work.

Compliance with this specification shall not relieve the bidder of the responsibility of furnishing



**TECHNICAL SPECIFICATION
ELECTRIC HOISTS & CHAIN PULLEY BLOCKS
1X800 MW NORTH CHENNAI FGD.**

material and workmanship to meet the specified working/duty conditions.

- 2.1.0 Electric hoist shall include but not be limited to the following: -
- a) Equipment offered shall be suitable for indoor duty conforming to Class II of IS: 3938.
 - b) Equipment shall be designed to operate in non- hazardous area.
 - c) Electric hoists shall be pendent operated.
 - d) Both hoisting and trolley movement shall be motor driven.
 - e) All motion shall be thru' VVVF drives to achieve creep speed of 10% of main speed.
 - f) Wheels shall be single flanged type.
 - g) Hook shall be swiveling type and fitted with a safety latch.
 - h) Control panel shall be hoist mounted.
 - i) Power feeding to the electric hoists shall be thru' PVC Cu shrouded DSL.
 - j) Brakes shall be fail to safety.
 - k) Load/overload testing of the hoists shall be carried out as per IS: 3938.
 - l) All material, castings and forgings will be of tested quality & certificates shall be made available for review as per approved QAP
- 2.2.0 Erection and Commissioning spares (ELECTRIC HOIST)
The Bidder shall also supply erection & commissioning spares along with his main equipment as per his experience, for replacement of damaged or unserviceable parts during the execution of the project at site, to avoid delay in the project schedule. This shall form part of the main equipment supply. The Purchaser shall retain the unutilized commissioning spares. The initial fill of lubricants, oil etc. shall also be supplied by the bidder.
- 2.3.0 Services to be provided by the bidder
Packing, forwarding and transportation to site, storage and handling at site.
- 2.4.0 Erection and Commissioning
- 2.5.0 Functional test (Overload testing, load testing at rated speed, travel and hoisting motion checks as per relevant Indian standards)
- 2.6.0 Obtaining clearance and acceptance certificate from the concerned competent authority after site test as applicable. Necessary fees/expenditure as required shall be borne by the supplier.

3.0 Inspection and Testing

As per enclosed reference quality plan and as per IS 3938 (latest revision). Prime inspection agency shall be Consultant/ End Customer. Equipment supplied shall be strictly in accordance with nomenclature & technical specification. Any additional testing requirement/CHP (Customer Hold Point) at any stage of inspection deemed necessary by Consultant/ End Customer during detailed engineering shall be carried out without any commercial or technical implication.

4.0 Works Excluded

Supply of ISMB monorail.

5.0 PAINTING SPECIFICATION

As per painting details specified elsewhere in specification.

6.0 PACKING

In general packing shall be wooden box packing.

7.0 TESTING AT VENDOR'S WORKS

Hoist along with its drives, controls and other accessories shall be demonstrated for the rated capacity against the rated speed of motions and for the service conditions specified as specified in QAP and as per IS 3938 for electric hoist and IS 3832 for manual hoist.

The bidder shall have the full responsibility for the safe and efficient operation of the hoist with associated accessories as a single unit.

If the shop performance tests indicate the failure of any of the components to achieve the



**TECHNICAL SPECIFICATION
ELECTRIC HOISTS & CHAIN PULLEY BLOCKS
1X800 MW NORTH CHENNAI FGD.**

guaranteed performance, the deficiency shall be made good at bidder's cost.

Demonstration tests shall be carried out each time after the rectification /modification is carried out.

8.0 MAKE OF SUB - VENDOR ITEMS

Makes of bought out items will be as per list specified in the specification. No other make will be acceptable, until and unless specifically got it approved by the purchaser/ end client. (Refer annexure-I)

9.0 TESTING AT SITE

A) ELECTRIC HOIST:

As required for statutory clearance for operating at site i.e., overload test, load test and other tests as per IS 3938.

Test for Operation -After the supply has been connected, tests shall be carried out to prove the following:

- a) The satisfactory operation of each controller, switch, contactor, relay and other control devices and in particular the correct operation of all limit switches under the most unfavorable conditions;
- b) The correctness of all circuits and interlocks and sequence of operation; and
- c) The satisfactory operation of all protective devices.

Overload Test -After test but before the hoist is put into service, it shall be tested with overload relays appropriately set, to lift and sustain a test load of 125 percent of the working load. During the overload test, the hoist shall sustain the load under full control. The specified speeds need not be attained but the hoist shall show itself capable of dealing with the overload without difficulty.

B) MANUAL HOIST:

As required for statutory clearance for operating at site with following minimum test i.e., overload and load test.

10.0 TECHNICAL DATA SHEET:

A) Technical data sheet-A for ELECTRIC HOIST:

Sl.no	DESCRIPTION	TECHNICAL PARTICULARS
1.0	Type	Steel wire electric hoist with electrically operated trolley
2.0	Scope (Qty., Capacity, Lift, Travel Length)	As mentioned in specification
3.0	Type of service	Indoor
4.0	Overload test	125% of SWL
5.0	Design Ambient temperature	50° C
6.0	General Design	As per IS: 3938 / 1983 or latest, Class-II duty
7.0	Operating speed	
7.1	Hoisting speed/ Creep speed (thru' VVVF drive)	3.5 m/min to 5 m/min with creep speed 10% of main speed.
7.2	Trolley speed	5 m/min to 10 m/min with creep speed 10% of main speed
8.0	Type of transmission	Through Electric motor and gear box.



**TECHNICAL SPECIFICATION
ELECTRIC HOISTS & CHAIN PULLEY BLOCKS
1X800 MW NORTH CHENNAI FGD.**

9.0	Wire Rope	
9.1	Construction / core	6 x 36 or 6 x 37 construction, steel/ Fibre core
9.2	Code	IS:2266
9.3	Tensile designation	1770/1960 N/mm ²
9.4	Number of falls	Min. 4
9.5	Factor of safety	Not less than 5
10.0	Load Hook and block	Normalized hook only
10.1	Type of load hook	Plain shank trapezoidal section with safety latch.
10.2	Load hook Code	IS: 15560
10.3	Load hook Material	Alloy steel/carbon steel as per IS:15560
10.4	Hook suspension	Thrust bearing
10.5	Material of block suspension	Fabricated from steel plate, Material: IS: 2062
10.6	Hook can swivel freely under full load	Yes
10.7	Safety latch on hook provided	Yes
10.8	Locking device on swivelling hook	Provided
10.9	Bearing type	Antifriction Ball / Roller
10.10	Bearing life	10,000 working hours.
11.0	Gearing	
11.1	Type	Spur / Helical, hardened and tempered with machine cut teeth
11.2	Gear material	Forged steel as per IS 3938
11.3	Lubrication	Oil splash/ grease lubricated
11.4	Bearing type	Antifriction Ball / Roller
11.5	Bearing life	10,000 working hours.
12.0	Trolley drive	
12.1	Wheel	Single flange taper thread
12.2	Wheel conform to (Std. / code)	IS: 3938
12.3	Wheel material	Heat treated carbon steel/ low alloy steel, graded cast iron.
12.4	Bearing type	Antifriction Ball / Roller
12.5	Bearing life	10,000 working hours.



**TECHNICAL SPECIFICATION
ELECTRIC HOISTS & CHAIN PULLEY BLOCKS
1X800 MW NORTH CHENNAI FGD.**

12.6	Trolley type	Rolled structural steel with side plates extended beyond wheel flanges to protect wheels.
12.7	Hardness	Max hardness 200 BHN
13.0	SHEAVE	
13.1	Material	Cast steel or mild steel.
13.2	Bearing type	Antifriction Ball / Roller.
13.3	Bearing life	10,000 working hours.
14.0	BRAKE (HOIST)	
14.1	Type	DC EM brakes disc type (fail to safety).
14.2	Capacity	As per IS 3938.
14.3	Number	One number for each motor.
14.4	Torque	150% of rated torque or greater than the torque transmitted to the brake drum from the suspended load up-to the test load.
15.0	BRAKE (TROLLEY)	
15.1	Type	DC EM brakes disc type (fail to safety).
15.2	Capacity	As per IS 3938.
15.3	Number	One number for each motor
15.4	Torque	150% of rated torque
16.0	ROPE DRUM	
16.1	Material	Cast iron, cast steel or mild steel.
16.2	Flange / Flangeless	Flanged
16.3	Type of groove	As per manufacturers standard to suit the layout requirement.(Shall be decided during detail engineering)
17.0	TYPE OF DSL	
17.1	CT travel	PVC shrouded Cu conductor bus bar -DSL shall be sized with a margin of 10% over load requirement.
18.0	MOTORS	
18.1	Type	Sq. Cage induction, TEFC, S4 duty, 40% CDF.
18.2	Number of start	300starts / hr, Motors shall be suitable for direct on-line (DOL) starting
18.3	Voltage , Phase and Frequency	Suitable for rated frequency of 50 Hz with a voltage variation of +/-10% and frequency variation of +3 to -5% occurring separately or combined voltage and frequency variation of 10%. 3 phase, 3 wire
18.4	Class of insulation	Class "F" and temperature rise limited to class B.



**TECHNICAL SPECIFICATION
ELECTRIC HOISTS & CHAIN PULLEY BLOCKS
1X800 MW NORTH CHENNAI FGD.**

18.5	Type of enclosure	TEFC	
18.6	Degree of protection provided for enclosure	IP-55	
18.7	Margin	Motor nameplate rating at 50 deg C shall have Motor rating will be calculated keeping margin of at least 10% over the maximum power requirement.	
19.0	LIMIT SWITCHES	Hoisting	Trolley
19.1	Type	One (1) no. Snap action, self-actuating type	One (1) no. two way limit switch
20.0	Control panel	<ul style="list-style-type: none"> * Fabricated from CRCA sheet steel not less than 1.6 mm thick * Degree of protection shall be IP 52 * Power on indicating lamps shall be provided * Panel illumination lamps operated by door switch. * 2 nos earthing terminals on panel. * Gland plate thickness shall be minimum 3mm. * Gland plate shall be double brass compression type. 	
20.1	Qty	1 No.	
21.0	Pendent Push buttons	Up /down / forward / Reverse push buttons. Indicative marking for easy operation shall be provided.	
22.0	Fixed type Power cables	Copper/Aluminum material, minimum size : Min. 2.5 mm ² for Cu, Extruded PVC insulated, armoured and FRLS PVC sheathed heavy duty 1100 V	
23.0	Fixed type Control cable	Copper material, min. 1.5 mm ² Control cables shall have stranded copper conductor, Extruded PVC insulated, armoured and FRLS PVC sheathed heavy duty 1100 V	
24.0	Trailing cable (Power/ Control)	EPR insulated, copper conductor trailing cables, as per IS:9968.	
25.0	Control Voltage	110 V	
26.0	End stopper for CT	2 nos., MOC shall be as per IS 2062	
27.0	Buffer for CT	2 nos. Spring/rubber type shall be provided on trolley	
28.0	Bearing (Type/life)	Antifriction Ball / Roller, 10,000 working hours life	

B) MANUAL HOIST (CHAIN PULLEY BLOCK):

DATA SHEET-A

1.0	Type	Chain pulley block with/without trolley
2.0	General Design	IS: 3832
3.0	Duty Class as per IS:3832	Class –II
4.0	Hoisting Mechanism	
a)	Type	Hand operated gear transmission
b)	Type of gear	Spur / Helical
c)	Load Chain	
i)	Type	Link type
ii)	Material	As per relevant standard
iii)	Conforms to (Std./Code)	IS: 6216 / IS 3077/IS 3019
d)	Hand Chain	



**TECHNICAL SPECIFICATION
ELECTRIC HOISTS & CHAIN PULLEY BLOCKS
1X800 MW NORTH CHENNAI FGD.**

i)	Type	Link type
ii)	Material	Mild steel Grade 30
iii)	Conform to Std.	IS:2429 (Part II)
e)	Load Hook & Hook Block	
i)	Type of load hook	Plain shank- Trapezoidal section/ 'C' type
ii)	Load hooks conforms to	IS: 15560
iii)	Type of hook suspension	Swivelling type with safety latch
iv)	Type of make of bearing	Thrust ball bearing of hook suspension
v)	Type & Material of hook	As per IS 15560
f)	Gears/ Pinions	
i)	Type	Spur
ii)	Material	Alloy steel / carbon steel/ High graded cast iron
	Type of Bearing	Antifriction ball bearing / Roller
g)	Sprockets :	
	Type of bearings used	Antifriction ball bearing / Roller
i)	Method of lubrication	
	Bearings	Grease
	Gearing & Pinions	Grease
	Sprocket	Grease
h)	Brakes	
	Type	Screw and friction disc type
5.0	Trolley and Bridge drive	
a)	Trolley	
i)	Type	Geared (Manually operated)
ii)	Material of frame	Mild steel (IS:2062 Grade A or B)
b)	Drive Chain	
i)	Type	Link type
ii)	Material	Steel Gr.30
iii)	Design of drive chain	IS : 2429 part 1 :1870
c)	Wheel	
i)	Number of pairs of wheel	Two in each trolley/bridge
ii)	Flange	Single flanged
iii)	Type of bearings need	Antifriction
iv)	Wheel material	As per IS 3832
d)	Gears	
i)	Type	Spur / helical
ii)	Material	Cast iron/EN8
iii)	Type of bearings used	Antifriction
e)	Method of lubrication for	
i)	Bearings	Grease
ii)	General	Grease
iii)	Sprockets	Grease
6.0	Painting	As per manufacturer's standard

11.0 Maintenance Tools and Tackles

One (1) complete unused new set of special purpose tools, tackles and accessories along with detailed instructions and maintenance manual shall be supplied. Tools shall be of suitable sizes for maintenance of electric hoist of each type and capacity. Each tool and wrench shall be stamped so as to be identified easy for its use. The tools shall be supplied in steel toolbox and with a copy of instruction manual. The items supplied shall be of the best quality, specially protected against rusting.



**TECHNICAL SPECIFICATION
ELECTRIC HOISTS & CHAIN PULLEY BLOCKS
1X800 MW NORTH CHENNAI FGD.**

The following shall be provided as minimum requirement:

S. No.	Description	Qty.
1	Complete set of ring spanners	1 Set
2	Complete set of screwdrivers (Min. 6 nos of suitable sizes)	1 Set
3	Adjustable Spanner	1 No.
4	Insulated pliers	1 No.
5	Wrench spanner	1 No.
6	Grease Gun	1 No.
7	Oil Gun	1 No.
8	Hand Lamp	1 No.
9	Line tester	1 No.

Note: -The tools shall be supplied in one tool box .Bidder shall ensure that the tools & tackles mentioned in above list are sufficient to handle all sizes/capacities of hoists & in case any other /additional tool is required for handling/maintenance any size/capacity of hoist the same shall be included in this list.

12.0 DRAWING/DOCUMENT SUBMISSION

The successful bidder shall submit the following drawings / documents during detail engineering for customer's approval /information:

A) ELECTRIC HOIST

SI. No.	BHEL DRG.NO	DRAWING TITLE
1	PE-V0-485-553-A100	Manufacturing Quality Plan with Sub vendor list
2	PE-V0-485-553-A101	GA Drawing for Electric Hoist, DSL arrangement and painting details
3	PE-V0-485-553-A102	Schematic Circuit Diagram
4	PE-V0-485-553-A103	Mechanism Sizing Calculation
5	PE-V0-485-553-A105	O & M Manual

B) MANUAL HOIST (CHAIN PULLEY BLOCK):

SI. No.	BHEL DRG.NO	DRAWING TITLE
1	PE-V0-485-553-A200	Manufacturing Quality Plan
2	PE-V0-485-553-A201	GA Drawing for Chain Pulley Block with detail BOM with painting details
3	PE-V0-485-553-A202	O & M Manual

Notes:

1. The above drawing list is tentative and shall be finalized with the successful bidder after placement of order.
2. Drawings shall be prepared in Auto-Cad latest edition. Required no. of hard and soft copies (editable) of the drawings shall be furnished as per requirement specified elsewhere in the specification.



**TECHNICAL SPECIFICATION
ELECTRIC HOISTS & CHAIN PULLEY BLOCKS
1X800 MW NORTH CHENNAI FGD.**

3. All the drawings and documents including general arrangement drawing, data sheet, calculation etc. to be furnished to the customer during detailed engineering stage shall include / indicate the following details for clarity w.r.t. Inspection, construction, erection and maintenance etc.:-
- a) All drawings and documents shall indicate the list of all reference drawings including general arrangement.
 - b) All drawings shall include / show plan, elevation, side view, cross - section, skin section, blow - up view; all major self-manufactured and bought out items shall be labeled and included in BOQ / BOM in tabular form.
 - c) Painting schedule shall also be made as a part of general arrangement drawing of each equipment / items indicating at least 3 trade names.
 - d) All the drawings required to be furnished to customer during detailed engineering stage shall include technical parameters, details of paints and lubrication, hardness and BOQ / BOM in tabular form indicating all major components including bought out items and their quantity, material of construction indicating its applicable code / standard, weight, make etc.
 - e) Drawings/ documents to be submitted for purchasers review/ approval shall be under Revision A, B, C... etc. while drawings /documents to be submitted thereafter for customer's approval after purchaser's approval shall be under R-0, 1, 2, 3etc.

13.0 MANDATORY SPARES:

MANDATORY SPARES FOR ELECTRIC HOIST (AS APPLICABLE)

A. For Electric Hoist

S. No.	Description	Qty.	Remarks
1	Electric Hoists (FOR EACH TYPE & CAPACITY)		
a	Bearings	1 Set	
b	Rope guide	1 Set	
c	Brake lining	1 Set	
d	Wire rope	1 Set	
	CABLES		
	Pre-fabricated cable of each type	10% of installed quantity	
	Pre-fabricated cable connector of each type	10% or 1 no. of each type and model, whichever is more	
	Other cables	5% of each type, pair and size of actual installed quantity	

Note: One(1) set consists of quantity required for complete replacement for one(1) hoist of each type & capacity.

Mandatory spares for Chain pulley block: Not required

ANNEXURE I: MAKES AND SUB VENDOR LIST



**TECHNICAL SPECIFICATION
ELECTRIC HOISTS & CHAIN PULLEY BLOCKS
1X800 MW NORTH CHENNAI FGD.**

Package Name	Vendor Name
ELECTRIC HOIST	Alpha Services
	CONSOLIDATED HOISTS PVT LTD
	CENTURY CRANE ENGINEERS PVT. LTD.
	TECHNO INDUSTRIES
	EDDY CRANES PVT. LTD.
	Grip Engineers Pvt. Ltd.,
	TRACTEL TIRFOR INDIA PVT. LTD.
	Mangla Hoists Pvt Ltd
	BRADY & MORRIS ENGINEERING CO. LTD.
	REVA INDUSTRIES LTD.
	UNIVERSAL HOIST-O-FABRIK
CHAIN PULLEY BLOCK	UNIVERSAL HOIST-O-FABRIK
	CENTURY CRANE ENGINEERS PVT. LTD.
	BAKELITE ELECTRICAL MFG. CO. PVT. LTD.
	TRACTEL TIRFOR INDIA PVT. LTD.
	BRADY & MORRIS ENGINEERING CO. LTD.
	TUOBRO FURGUSON (INDIA) PVT LTD
	TECHNO INDUSTRIES

Note: No other make will be acceptable, until and unless specifically got approved by BHEL/Customer / Customer's consultant during detail engineering only. Acceptance/non acceptance of same shall not have any impact on manufacturing, delivery schedule and on cost of the Electric hoists/CPB.

MAKES OF SUB VENDORS ITEMS AS APPLICABLE TO ELECTRIC HOIST:

Sl no.	ITEM	MAKES
1.0	STEEL	SAIL/IISCO/TATA STEEL / JINDAL
2.0	HOOKS	MOOZUMDAR / SIMRITI FORGING / HARMAN MOHTA / STEEL FORGING & ENGG. CO., KOLKATA /
3.0	GEAR COUPLINGS	ALLIANCE / HICLIFF / OEM
4.0	WIRE ROPE	USHA MARTIN Black / BOMBAY WIRE ROPES / FORT WILLIAMS / UNITED WIRE ROPE/BHARAT WIRE ROPES.
5.0	BEARINGS	SKF/ FAG
6.0	MOTORS	SIEMEN/ ABB /NGEF/ CROMPTON /KIRLOSKAR /GECA / BHARAT BIJLI / MARATHON / LHP.
7.0	BRAKES	STROM CRAFT/ ELECTROMAG /SPEED-O- CONTROL / EMCO LENZE
8.0	CONTACTOR	SIEMENS / L&T /TELE MECHANIQUE / BCH
9.0	OVER LOAD RELAYS	SIEMENS / L&T / TELE MACHANIQUE / ABB
10.0	HRC FUSES	SIEMENS / L&T/ ENGLISH ELECTRIC/GE Power
11.0	ISOLATING SWITCH	SIEMENS/ L&T / CONTROL & SWITCH GEAR
12.0	SWITCH FUSE UNITS	SIEMENS/ L&T/ CONTROL/ & SWITCH GEAR/ GEC A
13.0	TIME DELAY RELAYS	SIEMENS/ L&T/ ABB/ BCH/ GEC A
14.0	TRANSFORMERS	INDCOIL/AE / LOGICSTAT/ PRAGATI / KAPPA / SOUTHERN ELECTRIC
15.0	BULB & FLOURESCENT TUBES/FITTINGS	PHILIPS/ BAJAJ/ CROMPTON
16.0	CABLE LUGS (HEAVY DUTY)	DOWELLS
17.0	CABLES	
a)	POWER CABLES	NICCO / UNIVERSAL / INCAB / FORT GLOSTER TORRENT / CCI / ICL / RADIANT / FINOLEX/ POLYCAB/KEI/HAVELL
b)	CONTROL CABLES	NICCO / UNIVERSAL / INCAB / FORT GLOSTER / DELTON / FINOLEX / TORRENT / CCI / ICL / RADIANT POLYCAB / KEI/ HAVELL.



**TECHNICAL SPECIFICATION
ELECTRIC HOISTS & CHAIN PULLEY BLOCKS
1X800 MW NORTH CHENNAI FGD.**

c)	TRAILING CABLE	UNIVERSAL/ FGL/CCL/HVP/KEI/RADIANT.
18.0	CABLE GLAND	COMMET / SIEMEN / SUNIL&CO.
19.0	PUSH BUTTONS	SIEMENS / L&T / BCH /TEKNIC/VAISHNO
20.0	LIMIT SWITCHES	SPEED-O-CONTROL / ELECTROMAG / JAI BALA JI / KAYCEE / BCH
21	SELECTOR SWITCHES	KAYCEE/ SULZER
22	PENDENT PUSH BUTTON STATION	OEM
23	INDICATING LAMPS	TECKNIC / BCH / SIEMENS / STANDARD/ VAISHNO
24	MCB	MDS / INDO COPP / STANDARD
25	PANELS	OEM/BCH
26	DSL	SUSHEEL/STROMAG
27	TERMINAL BLOCKS	ELMEX/CONNECTWELL/WAGO (FOR CONTROL ONLY)
28	VVVF	YASAKAWA(L&T)/ABB/SIEMENS/SCHNIDER
29	CASTING	KOLHAPUR STEEL / GNAT FOUNDARY / KIRTI ALLOYS
30	Tools & tackles	Reputed make

MAKES OF SUB VENDORS ITEMS AS APPLICABLE TO MANUAL HOIST:

Sl no.	ITEM	MAKES
1.0	STEEL	SAIL/IISCO/TATA STEEL / JINDAL
2.0	HOOKS	STEEL FORGINGS/ KARACHIWALA/SMRITI/NASIK FORGE.
3.0	STEEL FORGINGS	CHOWDHARY/WESTERN INDIA FORGINGS/ HINDUSTAN STEEL FORGINGS/ RUBY FORGINGS OR AS APPROVED BY BHEL.
4.0	BRAKES	OEM

NOTE:

1. THE SUB VENDOR LIST ABOVE IS INDICATIVE ONLY AND IS SUBJECT TO BHEL AND CUSTOMER APPROVAL DURING DETAILED ENGINEERING STAGE WITHOUT ANY COMMERCIAL & DELIVERY IMPLICATION TO BHEL.

PAINTING SPECIFICATION

PAINTING SPECIFICATION



**TECHNICAL SPECIFICATION
ELECTRIC HOISTS & CHAIN PULLEY BLOCKS
1X800 MW NORTH CHENNAI FGD.**

1. Painting specification for steel structures:-

Surface preparation: De greasing and Mechanical cleaning with wire brush or blasting according to SIS 055900, Grade 2 ½ .

Primer : Zinc Silicate of approved brand. - 1 coat, DFT 75 µm per coat.

Intermediate : MIO Epoxy paint- 2 coats, DFT 100 µm per coat

Finish Coat : Polyurethane coating- 1 coat, DFT 75 µm per coat.

Total DFT : 350 µm

2. Painting specification for Indoor components such as motors, electrical parts etc:-

Surface preparation: blasting according to SIS 055900, Grade 2 ½ . Depending on production flow, a weldable, inorganic ethyl zinc silicate shop primer of minimum dry film thickness 25 µm may be used.

Primer : Zinc phosphate epoxy - 2 coat, Total DFT 75 µm.

Finish Coat : Chlorinated rubber paint- 2 coats, Minimum DFT 30-40 µm per coat.

Total DFT : 135 – 155 µm

3. Color Shade:

SL. No	Item Description	Color Shade	Remarks
1	Crane Structure	Golden Yellow shade 356 as per IS-5	Colour band-Black
2	Trolley and hook	Crimson shade 540 as per IS-5	
3	Motors	Light Gray shade 631 as per IS-5	
4	Control Panels	Light Gray (Powder coated) as per IS-5	
5	Bottom Block assembly.	Golden Yellow shade 356 as per IS-5	
6	End Carriage sweep.	Golden Yellow shade 356 as per IS-5	



VOLUME – II

SUB-SECTION - 2.5

CRANES & HOISTS

1.0.0 GENERAL

This part of the specification covers the requirements for Cranes and Hoists.

This section of the specification shall be read in conjunction with other sections of the specification as appropriate and the equipment offered shall meet the requirements as spelt out therein. The system shall comprise of cranes and hoists.

2.0.0 CODES AND STANDARDS

The equipment to be provided shall specifically conform to the latest editions of the following codes, standards, specifications and regulations. Also the system design shall conform to the requirements of applicable codes as specified in the General Technical Specification

ISO 1996	:	Noise Level
IS 3938	:	Hoist
IS 3177	:	Crane
IS 3832	:	Manual Hoist
IS 2266	:	Steel Wire Ropes for General Engineering Purposes
IS 15560	:	Point Hooks with Shank up to 160 Tonne – Specification
IS 13834 (Part-5) Cranes	:	Overhead travelling and portal bridge cranes - Classification
IS 325	:	Three Phase Induction Motors.

3.0.0 DESIGN REQUIREMENTS

Crane shall be provided in the areas where the handling of the equipment/components shall have requirement in both transverse and longitudinal direction. Otherwise, hoist shall be considered for handling. Curved monorail with hoist shall also be considered, if the equipment /components are not located in-line with the monorail. Height of the building shall be finalized considering the required lift over other equipment, piping etc.

Each crane or hoist shall be complete with its accessories, supporting structure, monorail beams, rails, girders, power supply, safety devices and controls and shall conform to local statutory rules and regulation.

- a) The crane and hoist shall be rigid in construction and all movements shall be smooth and non jerky, acceleration for cross travel and long travel motors shall be limited to reasonable values as to prevent any swinging of the load.
- b) In the design of components on the basis of strength, factor of safety shall not be less than Five (5) based on ultimate strength, impact, fatigue, wear and stress concentration factors shall be taken into account wherever applicable.
- c) Drives shall be designed with adequate margin to give best performance and efficiency. Safety arrangement shall be incorporated to prevent damage to the motors on account of mechanical overload and electrical faults and to gearing and shaft etc. due to over stressing and other detrimental condition.



- d) Casting and forging shall be of tested quality and shall confirm to their respective material specifications and shall be free from flaws and objectionable imperfection, machine true and in a workman like manner.
- e) Design shall provide easy maintenance of crane and hoist.
- f) Cranes and hoists capacity shall be selected by considering 25% margin over the weight of the heaviest component to be lifted.
- g) Crane and hoist selection criteria

Type of Handling equipment	Crane & Hoist's Safe working load (SWL)
CRANE	
Double Girder EOT Crane	> 10T
Single Girder over head / Under Slung cranes	≤ 10T
HOIST	
Electric hoists	≥ 2000 Kg
Manual hoists with trolley	> 500 Kg and < 2000 Kg

Note: Electrical hoists shall be provided at all equipments / components location which has a lift more than 10 m (for all >500 kg and < 2000 kg). Hook shall be provided for all possible maintenance location for the weight less 500kg.

- h) For guidance purposes the following crane & hoist speeds shall be considered:-

- **Crane**

~~Hoist : 5m/min~~

~~Trolley Travel : 10 to 15 m/min~~

~~Bridge Travel : 15 m/min~~

~~Creep speeds : 10% of operating speeds for all motion through VVVF~~

- **Hoist**

Hoisting speed : 3.5 m/min to 5 m/min

Travel speed : 5 m/min to 10 m/min

Creep speeds : 10% of operating speeds for all motion through VVVF

Permits and Inspection:

The contractor shall obtain and pay for necessary permits as required including license fees for installation and inspection of the same equipment, also make such tests as called for by the regulations of such authorized representatives of such authorities as well as in the present of the Owner's representative. The contractor shall be responsible to obtain license, certificate for operating at site.



ANNEX 2.5.1

SPECIFIED DESIGN DATA

SI.No.	Description	Unit	Data
A	CRANE		
1.0	General		
1.1	Type of control proposed		Pendant
2.0	Hoisting System		
2.1	Rope		As per IS 2266, Rope grade 1770
a)	Rope construction		IS 2266 / 6 x 36 multi strand construction Fibre core.
b)	Rope quality (material)		Extra flexible plough steel
c)	Factor of safety		Not less than 5
2.2	Rope drum		Hoist drum length shall be such that each lead of wire rope has a minimum of two full turns on the drum when the hook is at its lowest position not taking into consideration turns covered by wire rope anchorage and one spare groove for each lead of wire rope on the drum when the hook is at its highest position.
a)	Drum material		Fabricated from carbon steel as per IS 2062, Grade B and stress relieved or seamless pipe as per ASTM A 106 Grade A or B.
b)	Whether stress relieved		Yes (if fabricated)
2.3	Bearing type		Antifriction ball or roller
2.4	Hook		
a)	Hook type		Swivel "C" type single shank of suitable grade of either circular or standard trapezoidal section, point hook suitably heat treated with adequate lifting capacity. Swivel lock pin shall be provided.
b)	Hook material		Forged steel
c)	Safety latches provided		Yes
d)	Hook suspension		Thrust Bearing
2.5	Sheave material		Fabricated from cast steel / steel plate IS 2062 Gr A or B / CS Gr 280-520 IS 1030
2.6	Hoist Brake		
a)	Type		DCEM "fail to safe"
b)	Torque		150% of rated torque or greater than the torque transmitted to the brake drum from the suspended load up to the test load.
2.7	Gear box		Fabricated Fe 410w IS:2062-Gr A/B & stress relieved
a)	Material of gears		EN 9 / 55C8



Sl.No.	Description	Unit	Data
b)	Material of pinions		EN 19 / EN 24
c)	Type of gears & pinions		Spur / helical
2.8	Limit Switch type		Rotary geared + gravity type
3.0	Cross Travel		
3.1	CT brake		
a)	Type		DCEM "fail to safe"
b)	Torque	Nm	150% of rated torque
3.2	Gear box		Fabricated Fe 410w IS:2062 Gr A/B & stress relieved
a)	Material of gears		EN 9 / 55C8
b)	Material of pinion		EN 19 / EN 24
c)	Type of gears & pinion		Spur / Helical
3.3	Wheels		
a)	Materials		Forged steel
b)	Hardness	BHN	Not more than 200BHN
c)	Type		Single flanged
d)	Wheel bearing type		Antifriction Ball/Roller
3.4	Type of limit switches		Lever
4.0	Long Travel		
4.1	CT brake		
a)	Type		DCEM "fail to safe"
b)	Torque	Nm	150% of rated torque
4.2	Gear box		Fabricated Fe 410w IS:2062 Gr A/B & stress relieved
a)	Material of gears		EN 9 / 55C8
b)	Material of pinion		EN 19 / EN 24
c)	Type of gears/pinion		Spur / Helical
4.3	Wheels		
a)	Materials		Overhead Crane – C55 Mn 75 for overhead crane & Steel used for wheel shall not contain more than 0.06% of Sulphur or Phosphorous. Under slung Crane – Forged steel
b)	Hardness	BHN	Overhead crane – 300 to 350 BHN for under slung crane – Not more than 200BHN
c)	Type		overhead crane – Double flanged under slung crane – Single flanged
d)	Wheel bearing type		Antifriction Ball/Roller
4.4	Type of limit switches		Lever
5.0	Type of Buffer Stoppers		Rubber / spring
6.0	Electrical		
6.1	Power supply		Shrouded type down shop leads (copper) shall be provided to supply power to crane. Power supply to



Sl.No.	Description	Unit	Data
			Crab shall be through flexible trailing conductors.
6.2	Rating		S4, 40% CDF
6.3	Number of starts/hour		300 starts/hour
B	ELECTRIC HOIST		
1	General		
1.1	Design according to standard service class/ load class		IS 3938 Class II
1.2	Location (Indoor/ Outdoor)		(Based on the location)
1.3	Type of control		Pendant
2	Hoisting System		
2.1	Wire Rope		
a)	Rope construction		IS 2266 / 6 x 36 multi strand construction Fibre core.
b)	Rope quality (material)		Extra flexible plough steel
c)	Factor of safety		Not less than 5
2.2	Rope drum		
a)	Drum material		Fabricated from carbon steel as per IS 2062, Grade B and stress relieved or seamless pipe as per ASTM A 106 Grade A or B.
b)	Whether stress relieved		Yes (if fabricated)
c)	Bearing type		Antifriction ball or roller
2.3	Hook		
a)	Hook type		Swivel "C" type single shank of suitable grade of either circular or standard trapezoidal section, point hook suitably heat treated with adequate lifting capacity. Swivel lock pin shall be provided.
b)	Hook material		Forged steel
c)	Safety latches provided		yes
d)	Hook suspension		Thrust Bearing
e)	sheave material		Fabricated from cast steel / steel plate IS 2062 Gr A or B / CS Gr 280-520 IS 1030
2.4	Hoist Brake		
a)	Type		DCEM "fail to safe"
b)	Torque	Nm	150% of rated torque or greater than the torque transmitted to the brake drum from the suspended load up-to the test load.
2.5	Gear box		Fabricated Fe 410w IS:2062 Gr A/B & stress relieved
a)	Material of gears		EN 9 / 55C8
b)	Material of pinions		EN 19 /EN 24
c)	Type of gears & pinions		Spur / helical
2.6	Type of Limit Switch		Rotary geared + gravity type



Sl.No.	Description	Unit	Data
3	Travel		
3.1	CT brake		
a)	Type		DCEM “ fail to safe”
b)	Torque	Nm	150% of rated torque
c)	Gear box		Fabricated Fe 410w IS:2062 Gr A/B & stress relieved
i)	Material of gears		EN 9 / 55C8
ii)	Material of pinion		EN 19 / EN 24
iii)	Type of gears & pinion		Spur / Helical
d)	Wheels		
i)	Materials		Forged steel
ii)	Hardness	BHN	Not more than 200BHN
iii)	Type		Single flanged
iv)	Wheel bearing type		Antifriction Ball / Roller
e)	Type of Limit switches		Lever
4	Rating		S4, 40% CDF
5	Number of starts/hour		150 starts / hr
C	MANUAL HOIST		
1	Standards		IS 3832 / Class-II
2	Application		(Based on location)
3	Trolley and hoist operation		Hand operated
4	Material of construction		
4.1	Trolley frame		Cast steel / Mild steel
4.2	Gears (Trolley)		Machine cut cast steel / Forged steel / C40 / C50
4.3	Lifting hook (Swivel)		Shank 'C'. Forged steel. Safety latch and swivel lock pin.
4.4	Gears		IS 3681/4460
5	Trolley wheel		Forged / cast steel / C40 with minimum 200BHN and single flanged to suit standard I beam section.
6	Brake		Screw and disc friction type

STANDARD ELECTRICAL SCOPE BETWEEN BHEL AND VENDOR (FOR EPC PROJECTS)

PACKAGE: ELECTRIC HOIST FOR AC VENTILATION

PROJECT 1x800 MW NORTH CHENNAI FGD

SCOPE OF VENDOR: SUPPLY , ERECTION & COMMISSIONING OF VENDOR'S EQUIPMENT

<u>S. NO</u>	<u>DETAILS</u>	<u>SCOPE SUPPLY</u>	<u>SCOPE E&C</u>	<u>REMARKS</u>
1	Isolating Switch	Vendor	Vendor	BHEL will provide one number 415 V(3ph, 3W) supply feeder only up to isolating switches for cranes. Any other voltage level (AC/DC) required will be derived by the vendor. Motor starter shall be part of crane control panel.
2	Power cables, control cables, screened control cables and any special cables (if required) between equipment supplied by vendor.	Vendor	Vendor	Cable from supply feeder to isolating switch shall be in BHEL scope.
3	Cabling material (cable trays, accessories, cable tray supporting system, conduits etc).	Vendor	Vendor	
4	Equipment Earthing	Vendor	Vendor	All equipment metallic enclosures / frames, metal structure etc. shall be grounded at two points each to the nearest grounding points / risers provided by BHEL.
5	Motors	Vendor	Vendor	
6	Cable glands and lugs for equipment supplied by vendor	Vendor	Vendor	<ol style="list-style-type: none"> 1. Double compression Ni-Cr plated brass cable glands 2. Solder less crimping type heavy duty tinned copper lugs for power & control cables.
7	<ol style="list-style-type: none"> a) Input cable schedules (C & I) b) Cable interconnection details for above c) Cable block diagram 	Vendor Vendor Vendor	- - -	Cable listing for Control and Instrumentation Cable in enclosed excel format shall be submitted by vendor during detailed engineering stage.
8	Equipment layout drawings	Vendor	-	
9	Electrical Equipment GA drawing	Vendor	-	For necessary interface review.

	MANUFACTURER'S NAME & ADDRESS :	MANUFACTURING QUALITY PLAN ITEM : Chain Pulley Block QP No.: REV.:0, Date.: , PAGE: 1 OF 4	PROJECT : 1X800 MW NORTH CHENNAI FGD. PACKAGE : CHAIN PULLEY BLOCK

Sr. No.	COMPONENT / OPERATION	CHARACTERISTICS	CLASS	TYPE OF CHECK	QUANTUM OF CHECK		REFERENCE DOCUMENT	ACCEPTANCE NORMS	FORMAT OF RECORD	AGENCY			REMARKS
					M	C/N				M	C	N	
1.	2.	3.	4.	5.	6.		7.	8.	9.	10.			11.

1	<u>RAW MATERIAL & B/OUT ITEMS:</u>													
1.1	HOOKS	CHEMICAL & MECH MARK & IDENTIFICATION INTERNAL DEFECTS PROOF LOAD TEST NDT AFTER PROOF LOAD TEST	MA MA MA MA MA	LAB ANALYSIS VISUAL UT REVIEW DPT	ONE SAMPLE PER HEAT 100% 100% 100% 100%	MATERIAL SPECIFICATION AS PER APPROVED DRAWINGS. HOOK TC FROM COMPETENT AUTHORITY ASTM A-388 (REFER NOTE I) IS 15560 NO RELEVANT INDICATION ASTM E-165	APPD. DRGS	APPD. DRGS.	MTC. TC IR TC TC	✓ ✓ ✓ ✓ ✓	P P P P P	V V V V V	V V V V V	ON SHANK PORTION
1.2	LOAD CHAIN	- DIMENSIONS - BREAKING STR & % ELONGATION - PROOF LOAD -HEAT TREATMENT -GRADE	MA MA MA MA MA	MEASUREMENT -TENSILE TEST -TENSILE TEST REVIEW REVIEW	100% 1/LOT 100% 100% 1/BATCH		-DO- -DO- -DO-	-DO- -DO- -DO-	IR MTC MTC HT CHRT MTC	✓ ✓ ✓ ✓ ✓	P P P P P	V V V V V	V V V V V	

	LEGEND:	FOR CUSTOMER USE	
MANUFACTURER / CONTRACTOR	** M : MANUFACTURER / SUB-SUPPLIER C : BHEL / NOMINATED INSPECTION AGENCY. N : CUSTOMER/ NOMINATED INSPECTION AGENCY. INDICATE "P" PERFORM "W" WITNESS AND "V" VERIFICATION		
SUB-CONTRACTOR		REVIEWED BY	NAME & SIGN OF APPROVING AUTHORITY & SEAL
SIGNATURE			

	MANUFACTURER'S NAME & ADDRESS :	MANUFACTURING QUALITY PLAN ITEM : Chain Pulley Block QP No.: REV.:0, Date.: , PAGE: 2 OF 4	PROJECT : 1X800 MW NORTH CHENNAI FGD. PACKAGE : CHAIN PULLEY BLOCK

Sr. No.	COMPONENT / OPERATION	CHARACTERISTICS	CLASS	TYPE OF CHECK	QUANTUM OF CHECK		REFERENCE DOCUMENT	ACCEPTANCE NORMS	FORMAT OF RECORD	AGENCY			REMARKS
					M	C/N				M	C	N	
1.	2.	3.	4.	5.	6.		7.	8.	9.	10.			11.

1.3	RAW MATL. (BAR /FORGING) FOR GEAR BLANKS/SHAFTS/ PINIONS/AXLE/ RATCHET PAWL / RATCHET WHEEL & PLATES FOR FABRICATION ETC	CHEMICAL COMPOSITION	MA	Review	ONE SAMPLE PER HEAT	Material specification as per approved drawings. ASTM A-388 REFER NOTE 1 ASTM E-165 NO RELEVANT INDICATION	APPD. DRG.	APPD. DRG.	MFR'S TC	✓	P	V	V	TC or inspection report for components shall be given. For rounds ≥50mm and plates ≥25 mm.	
		MECHANICAL	MA	Review					IR	✓	P	V	V		
		INTERNAL DEFECTS	MA	UT	100%					TC	✓	P	V		V
		NDT AFTER MACHINING	MA	DPT	100%							P	V		V
1.4.	LOAD CHAIN WHEELS	- CHEMICAL & MECHANICAL PROPERTIES	MA	CHEMICAL MECHANICAL PROPERTIES	ONE SAMPLE PER LOT			MTC	✓	P	V	V			
1.5	BEARINGS	MAKE, TYPE, CATALOGUE NO.	MA	VISUAL	RANDOM	APP DRG / MFR'S CATALOGUE	APP DRG / MFR'S CATALOGUE	IR	✓	P	V	V			
1.6	HAND CHAIN WHEEL	CHEMICAL MECHANICAL PROPERTIES	MA	CHEMICAL MECHANICAL PROPERTIES	ONE SAMPLE PER LOT	AS PER DRAWING	AS PER DRAWING	MTC	✓	P	V	V			
1.7	HAND CHAIN	GRADE/ DIMENSION	MA	GRADE DIMENSION	100%	AS PER DRAWING	AS PER DRAWING	MTC	✓	P	V	V			

MANUFACTURER / CONTRACTOR	LEGEND:	FOR CUSTOMER USE	
SUB-CONTRACTOR	** M : MANUFACTURER / SUB-SUPPLIER C : BHEL / NOMINATED INSPECTION AGENCY. N : CUSTOMER/ NOMINATED INSPECTION AGENCY. INDICATE "P" PERFORM "W" WITNESS AND "V" VERIFICATION	REVIEWED BY	NAME & SIGN OF APPROVING AUTHORITY & SEAL
SIGNATURE			

	MANUFACTURER'S NAME & ADDRESS :	MANUFACTURING QUALITY PLAN ITEM : Chain Pulley Block QP No.: REV.:0, Date.: , PAGE: 3 OF 4	PROJECT : 1X800 MW NORTH CHENNAI FGD. PACKAGE : CHAIN PULLEY BLOCK
---	---------------------------------	---	---

Sr. No.	COMPONENT / OPERATION	CHARACTERISTICS	CLASS	TYPE OF CHECK	QUANTUM OF CHECK		REFERENCE DOCUMENT	ACCEPTANCE NORMS	FORMAT OF RECORD	AGENCY			REMARKS
					M	C/N				M	C	N	
1.	2.	3.	4.	5.	6.		7.	8.	9.	10.			11.

1.8	TROLLEY GEARS, PINION, WHEELS, AXLE	CHEMICAL & MECHANICAL	MA	LAB ANALYSIS,	100%	APPVD DRGS	APPVD DRGS	IR/TC	✓	P	V	V	
2	IN PROCESS												
2.1	RATCHET PAWL / RATCHET WHEEL	-HARDNESS -SURFACE CRACK	MA MA	HARDNESS DPT	100% 100%	IS:3832/ APPD DRG. ASTM E165	IS:3832/ APPD. DRG. NO DEFECT	IR IR	✓ ✓	P P	V V	V V	
2.2	COMPONENTS AFTER HARDFACING & MACHINING	HEAT TREATMENT SURFACE HARDNESS SURFACE CRACK DIMENSION	MA MA MA MA	HT CHART HARDNESS DPT FOR SURFACE CRACK MEASURE	100% 10% 100% 10%	IS 1875/IS 4367/IS 3832 --DO-- ASTM E 165	NO DEFECT	IR IR IR IR	✓ ✓ ✓ ✓	P P P P	V V V V	V V V V	
3.0	FINAL INSPECTION												
3.1	COMPLETE ASSEMBLY	OVERALL DIMENSION ENDURANCE TYPE TEST OPERATIONAL PROOF LOAD & LIGHT LOAD TEST, EFFORT.	CR MA CR	MEASUREMENT TYPE TEST LOAD TEST	100 % 1 PER SIZE 100%	IS:3832 /APPD DRG IS 3832 -DO-	IS:3832 /APPD DRG IS 3832 -DO-	IR TC IR	✓ ✓ ✓	P P P P	V V V V	V V V V	

	LEGEND:	FOR CUSTOMER USE	
MANUFACTURER / CONTRACTOR	** M : MANUFACTURER / SUB-SUPPLIER C : BHEL / NOMINATED INSPECTION AGENCY. N : CUSTOMER/ NOMINATED INSPECTION AGENCY. INDICATE "P" PERFORM "W" WITNESS AND "V" VERIFICATION		
SUB-CONTRACTOR		REVIEWED BY	NAME & SIGN OF APPROVING AUTHORITY & SEAL
SIGNATURE			

	MANUFACTURER'S NAME & ADDRESS :	MANUFACTURING QUALITY PLAN ITEM : Chain Pulley Block QP No.: REV.:0, Date.: , PAGE: 4 OF 4	PROJECT : 1X800 MW NORTH CHENNAI FGD. PACKAGE : CHAIN PULLEY BLOCK
---	---------------------------------	---	---

Sr. No.	COMPONENT / OPERATION	CHARACTERISTICS	CLASS	TYPE OF CHECK	QUANTUM OF CHECK		REFERENCE DOCUMENT	ACCEPTANCE NORMS	FORMAT OF RECORD	AGENCY			REMARKS
					M	C/N				M	C	N	
1.	2.	3.	4.	5.	6.		7.	8.	9.	10.			11.

		HEIGHT OF LIFT SWIVELING OF HOOK	MA MA	VISUAL VISUAL	100 % 100%	-DO-APPROVED DRG -DO-	-DO-APPROVED DRG -DO-	IR IR	✓ ✓ ✓	P P	V V	V V	
3.2	PAINTING	-CLEANING - SHADE & DFT OF PAINT	MA MI	VISUAL VISUAL	AT RANDOM AT RANDOM	APPROVED DRAWING/ SPECIFICATI ON	APPROVED DRAWING/ SPECIFICATI ON	IR IR		P - p	--- V	-- ---	
3.3	NAME PLATE	VERIFICATION	MA	VISUAL	100%			IR		P	V	---	
3.4	PACKING	-VERIFICATION	MI	VISUAL	100%	SPECS.	SPECS.	IR		P	---	---	
3.5	REVIEW OF QA DOCUMENTATION	VERIFICATION	MA	VISUAL	100%	APPD. QP	APPD. QP		✓	V	V	V	

CR – CRITICAL, MA – MAJOR , MI – MINOR

NOTE 1: WHEN BACK WALL ECHO (BWE) IS SET AT 100% OF FULL SCREEN HEIGHT (FSH) IN DEFECT FREE AREA THEN

(A) DEFECT ECHO SHALL NOT EXCEED 20% OF FSH &

(B) BWE SHOULD BE MINIMUM 80% OF FSH IN ANY AREA.

NOTE 2: RECORDS IDENTIFIED WITH TICK SHALL BE ESSENTIALLY INLCUDED IN QA DOCUMENTATION.

	LEGEND:	FOR CUSTOMER USE	
MANUFACTURER / CONTRACTOR	** M : MANUFACTURER / SUB-SUPPLIER C : BHEL / NOMINATED INSPECTION AGENCY. N : CUSTOMER/ NOMINATED INSPECTION AGENCY. INDICATE "P" PERFORM "W" WITNESS AND "V" VERIFICATION		
SUB-CONTRACTOR		REVIEWED BY	NAME & SIGN OF APPROVING AUTHORITY & SEAL
SIGNATURE			

		MANUFACTURERS NAME & ADDRESS		MANUFACTURING QUALITY PLAN				PROJECT		1X8000 MW NORTH CHENNAI FGD			
		AS PER APPROVED VENDOR LIST		ITEM:	ELECTRIC WIRE ROPE	QP NO	PACKAGE		ELECTRIC WIRE ROPE HOIST				
						REV	0	CONTRACT No					
						DATE	CONTRACTOR		BHEL-PEM				
		PAGE	1 of 4										
Sl.No	COMPONENT & OPERATIONS	CHARACTERISTICS	CATEGORY	TYPE OF CHECK	EXTENT OF CHECK	REFERENCE DOCUMENT	ACCEPTANCE NORMS	FORMAT OF RECORD		AGENCY		REMARKS	
1	2	3	4	5	6	7	8	9	D*	M	C	N	11
											**	10	
1.0	RAW-MATERIALS												
1.1	a) STRUCTURAL MATERIAL b) RAW MATERIAL FOR HOIST AND GEAR BOX HOUSING, TROLLEY PLATE, ROPE DRUM IF FABRICATED ETC	CHEM & MECH PROPS	MA	Lab analysis	1 SAMPLE PER LOT%	IS 2062 /APPD. DRG./ DATA SHEET		MTC/IR	√	P/V	V	V	Test shall be carried out in absence of mill TC or non-correlation of TC with material.BHEL to identify Samples for testing. Test to be carried out at NABL accredited Lab. Reports to be submitted for verification during inspection.
		NDT	MA	UT	100%	ASTM A388-2004	NOTE 1	IR	√	P	V	V	For dia / plate thickness above 25 mm
1.1 A	SEAMLESS PIPE FOR ROPE DRUM	CHEMICAL , MECHANICAL	MA	Lab analysis	1 SAMPLE /pipe	Approved drg/ASTM A 106 Grade A or B		MTC/IR	√	P/V	V	V	Test shall be carried out in absence of mill TC or non-correlation of TC with material.BHEL to identify Samples for testing. Test to be carried out at NABL accredited Lab. Reports to be submitted for verification during inspection
		Flattening & Acid Etching test	MA	PHYSICAL & METALLOGRAPHY	1 SAMPLE /pipe	No cracks, pitting, rusting , damage etc		IR	√	P	V	V	
		SURFACE DEFECTS	MA	Visual	100%								
1.2	FORGINGS FOR GEARS BLANKS ,PINIONS, SHAFT/AXLES, WHEELS , STEEL CASTINGS	MECH , CHEM. PROPS	MA	Lab analysis	100%	APPD. DRG./ DATA SHEET	APPD. DRG./ DATA SHEET / IS:3938	LAB. REPORT / MANUFACTURER'S TEST CERTIFICATE	√	P	V	V	
		NDT	CR	UT	100%	ASTM A 388	NOTE 1	INSPN. REPORT	√	P	V	V	IF DIA or THK > 50mm
		Hardness , surface defects after hardfacing and machining / grinding	MA	DPT/MPI	100%	ASTM E -165 /E-709, No linear indication		MTC	√	P	V	V	
1.3	WIRE ROPE	Dimensional, type, constrction ,	MI	measurement	100%	APPD. DRG./ DATA SHEET	APPD. DRG./ DATA SHEET	MFRS' TEST CERT.	√	P	V	V	
		EXAMINATION OF REPORT OF BREAKING LOAD CAPACITY	CR	Review of TC	100%	IS: 2266		MFRS' TEST CERT.	√	P	V	V	

		MANUFACTURERS NAME & ADDRESS		MANUFACTURING QUALITY PLAN				PROJECT		1X8000 MW NORTH CHENNAI FGD			
		AS PER APPROVED VENDOR LIST		ITEM:	ELECTRIC WIRE ROPE	QP NO	PACKAGE		ELECTRIC WIRE ROPE HOIST				
						REV	0	CONTRACT No					
						DATE	CONTRACTOR		BHEL-PEM				
		PAGE	1 of 4										
Sl.No	COMPONENT & OPERATIONS	CHARACTERISTICS	CATEGORY	TYPE OF CHECK	EXTENT OF CHECK	REFERENCE DOCUMENT	ACCEPTANCE NORMS	FORMAT OF RECORD	AGENCY			REMARKS	
1	2	3	4	5	6	7	8	9	D*	M**	C	N	11
1.4	HOOKS	MECH. , CHEM. PROPS.	MA	Lab analysis	100%	APPROVED DRG/DATA SHEET IS:15560		MFRS' TEST CERT.	√	P	V	V	
		U.T IF SHANK DIA > 50mm	CR	NDT	100%	ASTM A 388	NOTE 1	INSPN. REPORT	√	P	V/W	V	SHANK PORTION ONLY
		Dimension & PROOF LOAD TESTING	CR	Measurment , PROOF LOAD TEST	100%	APPROVED DRG/DATA SHEET / IS:3938 / IS:15560		QCR	√	P	V/W	V	IF REQUIRED BY END CUSTOMER.
		DPT AFTER PROOF LOAD	CR	NDT	100%	ASTM E-165	NO CRACKS	INSPN. REPORT	√	P	V/W	V	
1.5	SHEAVES	MECH	MA	Tensile & hardness	1/lot	Approved drgs		MTC/IR	√	P	V	V	

		MANUFACTURERS NAME & ADDRESS		MANUFACTURING QUALITY PLAN				PROJECT		1X8000 MW NORTH CHENNAI FGD				
		AS PER APPROVED VENDOR LIST		ITEM:	ELECTRIC WIRE ROPE	QP NO	PACKAGE		ELECTRIC WIRE ROPE HOIST					
						REV	0	CONTRACT No						
						DATE	CONTRACTOR		BHEL-PEM					
		PAGE	1 of 4											
Sl.No	COMPONENT & OPERATIONS	CHARACTERISTICS	CATEGORY	TYPE OF CHECK	EXTENT OF CHECK	REFERENCE DOCUMENT	ACCEPTANCE NORMS	FORMAT OF RECORD		AGENCY			REMARKS	
1	2	3	4	5	6	7	8	9	D*	M**	C	N	10	11
1.6	CASTING FOR BEARING PLATED, ROPE GUIDES, PULLEYS ETC	CHEMICAL & MECHANICAL	MAJOR	LAB ANALYSIS	1/LOT	APPROVED DRG/MFG STANDARD	APPROVED DRG/MFG STANDARD	LAB REPORT	√	P	V	V		
2.0	IN-PROCESS													
2.1	Welding process capability and welder skill	WPS,PQR & WPQ	MA	Welding procedure approval and Welder performance qualification in accordance with ASME Section IX	100%	ASME Section IX		WPS,PQR & WPQ		P	V	V		In case approved WPS/PQR/WPQ from BHEL/NTPC/EIL/LLOYDS/TPL available, then documents/records to be submitted for verification during inspection, else, Vendor shall get the approval of Welding Procedure / Welder from the identified agency prior to carrying out welding at the
2.2	Welding of trolley, rope drum etc	Fillet weld	MA	DPT	10%	ASTM E165 or Eq/ No cracks or linear indication		INSPN. REPORT	√	P	V	V		
		Butt welds	MA	RT, DPT	100%	ASME SEC VIII, DIV 1, UW 51/52		RT FILM & REPORT	√	P	V	V		100% RT for butt weld in tension and 10 % in compression. 100% RT on butt weld of rope drum
		DPT AFTER STRESS RELIEVING OF ROPE DRUM	MA	NDT	100%	ASTM E-165	NO CRACKS	INSPN. REPORT	√	P	V	V		
2.3	NDT OF LOAD BEARING BUTT WELDS (IF ANY)	WELD QUALITY OF BUTT WELDS IN TENSION	CR	PT & RT	100%	ASME SEC. VIII DIV. I	ASME SEC. VIII DIV. 4 . CLUW-51 FOR RT APPENDIX -8 FOR PT	INSPN. REPORT ND FILM	√	P	W	V/W		FILMS TO BE REVIEWED BY BHEL & END CUSTOMER/THIRD PARTY. DPT SHALL BE CHP .
2.4	GEAR BOXES													
	COMPLETE ASSEMBLY	OVERALL DIMENSIONS. LEAK TEST, REDUCTION RATIO, BACK LASH AND CONTACT PATTERN	MA	MEAS./VISUAL	100%	MFG. DRG./KERSON E TEST	MFG. DRG./NO LEAKAGE WHEN FILLED	INSPN. REPORT	√	P	V			
	NO LOAD RUN TEST FOR 4 HRS	CHECK FOR OIL LEAKAGE, VIBRATION, NOISE ,TEMP. RISE, REDUCTION RATIO, BACKLASH , CONTACT PATTERN	MA	PERFORMANCE	100%	APPROVED DRGS /No leakage,Noise 85dba maxat 1 mtrs, vibration 75 microns max, oil temp rise 20 deg above ambient max		- DO -	√	P	V	V		
3.0	ELECTRICALS													
1	MOTORS & CABLES	Make, type , rating	MA	Visual /measurement	100%	Apprvd drg	IS 325 / IS:3938	IR, MTC	√	P	V	V		For motor refer Note: 2
		ROUTINE TESTS												
3	LIMIT SWITCHES,SFU, ISOLATOR/ O/L RELAY, MCB, FUSES,PUSH BUTTONS,CONTACTOR, INDICATING LAMPS etc	Make , type , rating, functional, Continuity	MA	Review of TC	100%	Approved drgs		IR	√	P	V	V		

		MANUFACTURERS NAME & ADDRESS		MANUFACTURING QUALITY PLAN				PROJECT			1X8000 MW NORTH CHENNAI FGD			
		AS PER APPROVED VENDOR LIST		ITEM:	ELECTRIC WIRE ROPE	QP NO	PACKAGE		ELECTRIC WIRE ROPE HOIST					
						REV	0	CONTRACT No						
						DATE	CONTRACTOR			BHEL-PEM				
		PAGE	1 of 4											
Sl.No	COMPONENT & OPERATIONS	CHARACTERISTICS	CATEGORY	TYPE OF CHECK	EXTENT OF CHECK	REFERENCE DOCUMENT	ACCEPTANCE NORMS	FORMAT OF RECORD		AGENCY			REMARKS	
1	2	3	4	5	6	7	8	9	D*	M**	C	N	10	11
4	BRAKES	Make , type , rating, HV/IR, Functional test	MA	Review of TC	100%	Approved drgs	IR, MTC	√	P	V	V			
5	DSL	Make , type , rating, dimension	MA	Review of TC	100%	Approved drgs	IR	√	P	V	V			
6	Control transformer	Make , type , rating, input/output	MA	Review of TC	100%	Approved drgs	IR	√	P	V	V			
7	CONTROL PANEL, PENDANT SWITCH	* FIXING OF COMPONENTS WIRING * MARKING CONTINUITY * FUNCTIONAL TEST * IR & H.V. TEST * IP - PROTECTION TEST * PAINT SHADE, THICKNESS, SHEET THICKNESS, ADHESION TEST	MA	VISUAL/MEASUR	100%	APPD.DRG. WIRING DIAGRAM,	APPD. DRG. WIRING DIAGRAM,	IR	√	P	V	V		
8	VVVF DRIVES (IF APPLICABLE)	MAKE , TYPE , RATING , ROUTINE TESTS	MA	VISUAL/ VERIFY	100%	APPROVED DRAWINGS	APPROVED DRAWINGS	MTC	√	P	V	V		
4.0	FINAL INSPECTION													

		MANUFACTURERS NAME & ADDRESS		MANUFACTURING QUALITY PLAN				PROJECT		1X8000 MW NORTH CHENNAI FGD				
		AS PER APPROVED VENDOR LIST		ITEM:	ELECTRIC WIRE ROPE	QP NO		PACKAGE		ELECTRIC WIRE ROPE HOIST				
						REV	0	CONTRACT No						
						DATE		CONTRACTOR		BHEL-PEM				
		PAGE	1 of 4											
Sl.No	COMPONENT & OPERATIONS	CHARACTERISTICS	CATEGORY	TYPE OF CHECK	EXTENT OF CHECK	REFERENCE DOCUMENT	ACCEPTANCE NORMS	FORMAT OF RECORD		AGENCY			REMARKS	
1	2	3	4	5	6	7	8	9	D*	M**	C	N	10	11
4.1	COMPLETELY ASSEMBLED HOIST	1. COMPLETENESS, CORRECTNESS, WELD QUALITY, OVERALL DIMENSIONS	MA	VISUAL, MEAS	100%	APPD. DRG.	APPD. DRG.	MNFRS' TEST CERT.	√	P	W	W	W	CHP
4.2	ASSEMBLED HOIST PERFORMANCE WITH ACTUAL CONTROL PANEL, AND PENDENT PUSH BUTTON	1. LOAD TEST	CR	LOAD TEST at SWL	100%	IS:6547 / IS:3938	IS:6547 / IS:3938	MNFRS' TEST CERT.	√	P	W	W	W	CHP
		2. HOISTING & LOWERING SPEED, PERFORMANCE OF CONTROLLERS SWITCHES CONTACTORS, RELAYS AND OTHER CONTROL DEVICES CORRELATIONS OF CIRCUITS AND INTERLOCKS AND SEQUENCES OF OPERATION , CURRENT MEASUREMENT,LIMIT SWITCH OPERATION.	CR	MEAS & VISUAL	100%	IS:3938, TECH SPEC.	TECH SPEC.	MNFRS' TEST CERT.	√	P	W	W	W	CHP
		3. OPERATION OF ALL PROTECTIVE DEVICES	CR	VISUAL	100%	TECH SPEC	TECH SPEC.	MNFRS' TEST CERT.	√	P	W	W	W	CHP
4.3	OVER LOAD TEST	OVER LOAD TEST INCLUDING HOLDING CAPACITY OF BRAKES, LIFTING LOAD FROM MID AIR, SOUNDNESS OF WELD AFTER OVERLOAD	CR	TEST AT 125 % OF-SWL	100%	IS:3938	IS:3938	INSPN. REPORT	√	P	W	W	W	CHP
5	PAINTING													
5.1	PRIMER & FINISHING AND SHADE	Examination - Shade , DOP by paper insertion method	MI	visual	100%	DRG. & DATA SHEET & RELV. IS SPEC.		MNFRS' TEST CERT.		P	V			
		DFT	MA	measurement	Sample					P	V			
6	PACKING	STURDINESS, PROTECTION MARKING	MA	VISUAL	100%	MFG STD	MFG STD			P				
	NOTE:													
1	When back wall echo is set to 100% in sound area then a) defect echo shall not exceed 20% b) Back echo shall be minimum 80% in any area.													
2	Less than 30 KW. Acceptance of motor less than 30 KW is based on COC of the manufacturer & the contractor confirming as follows : It is hereby confirmed that the above mentioned motor/motors was/were manufactured taking care of specific requirement regarding ambient temp, voltage & frequency variation, hot start, pull out torque, starting KVA/KW, temp rise, distance between centerof stud and gland plate and tested in accordance with approved drawing/data sheet.													

		MANUFACTURERS NAME & ADDRESS		MANUFACTURING QUALITY PLAN				PROJECT		1X8000 MW NORTH CHENNAI FGD		
		AS PER APPROVED VENDOR LIST		ITEM:	ELECTRIC WIRE ROPE	QP NO		PACKAGE		ELECTRIC WIRE ROPE HOIST		
						REV	0	CONTRACT No				
						DATE		CONTRACTOR		BHEL-PEM		
				PAGE	1 of 4							
Sl.No	COMPONENT & OPERATIONS	CHARACTERISTICS	CATEGORY	TYPE OF CHECK	EXTENT OF CHECK	REFERENCE DOCUMENT	ACCEPTANCE NORMS	FORMAT OF RECORD		AGENCY		REMARKS
									D*	M	C	N
1	2	3	4	5	6	7	8	9		**	10	11
		LEGND										
		* RECORDS IDENTIFIED WITH 'TICK' SHALL BE ESSENTIALLY INCLUDED BY MANUFACTURER IN QA DOCUMENTATION.										
		** M: MANUFACTURER/SUBCONTRACTOR										
		C: BHEL/BHEL NOMINATED THIRD PARTY INSPECTION AGENCY										
MANUFACTURER/ SUB CONTRACTOR		N: CUSTOMER/CUSTOMER'S CONSULTANT/CUSTOMER'S APPOINTED THIRD PARTY										
		'P'- PERFORM", W"- WITNESS AND "V"- VERIFICATION										
SIGNATURE		" CHP" CUSTOMER HOLD POINT					REVIEWED BY		NAME & SIGN OF APPROVING AUTHORITY &SEAL			



**1x800 MW TANGEDCO NORTH CHENNAI
TPP– (FGD SYSTEM)
HVAC SYSTEM
STANDARD TECHNICAL SPECIFICATIONS**

**SPECIFICATION No: PE-TS-485- (571-13000-
A)-A001 (REV-0)**

SECTION : I

SUB-SECTION : D

REV. 00

SECTION: I

SUB-SECTION: D

STANDARD TECHNICAL SPECIFICATIONS



TECHNICAL SPECIFICATION

AIR HANDLING UNITS

SPECIFICATION NO.PES-553-02

VOLUME II B

SECTION D

REV. 02

DATE: 17.09.2012

SHEET 1 OF 6

**STANDARD TECHNICAL SPECIFICATION
FOR
AIR HANDLING UNITS**



TECHNICAL SPECIFICATION

AIR HANDLING UNITS

SPECIFICATION NO. PES-553-02

VOLUME II B

SECTION D

REV. 02

DATE: 17.09.2012

SHEET 2 OF 6

1. GENERAL

1.1 This specification covers the design, manufacture, Construction features, installation, commissioning, inspection and performance testing at site of AHUs.

2. CODES AND STANDARDS

2.1 The design manufacture and performance of AHU shall comply with all currently applicable statutes, regulations and safety codes in the locality where the AHU is to be installed. The equipments shall also conform to the requirements of the latest editions of applicable Indian/British/US standards. Nothing in this spec. shall be construed to relieve vendor of this responsibility. In particular the equipment shall conform to the latest editions of the following standards:

2.1.1 IS-659 : Safety code for air conditioning

2.1.2 IS-660 : Safety code for mechanical refrigeration

2.1.3 ASHRAE: Method of testing forced circulation air-cooling and air heating coils.
standard 33

2.1.4 ARI 41 : Standard for forced circulation air cooling and air heating coils.

2.1.5 ARI 430/435 : Air-cooling and air heating coils Central Station AHU / Application of Central Station AHU.

2.1.6 AMCA : 211 and 311

In case of any conflict in the standards and this specification the decision of PEM, BHEL shall be final and binding.

3. CONSTRUCTION FEATURES

3.1 The casing of AHU shall be made of insulated double wall construction of min. 24 gauge galvanized sheet steel - IS 277 Gr. 120 (parent sheet: D/DD-IS-513) ribbed and reinforced for structural strength and rigidity with 25 mm thick polyurethane insulation of minimum 40 kg/m³ density in between. The external wall will be pre-plasticised over GI coating on the outside. Angle irons or channel sections made of 16 gauge galvanized sheet steel shall be used for reinforcing. The casing shall be of sectionalized construction with proper sealing at the joints to make them air tight. Fan section and panels with bearing support shall be reinforced with heavy gauge channels (min. 5 mm thick). Suitable number of forged hot dip galvanized (610 gm/sq.m) U brackets shall be provided for AHU suspended from ceiling/roof.

Necessary arrangement shall be provided on the casing for measuring temperature and pressure in cooling/heating coil. Class of instruments shall be min. 2.

3.2 Fan impeller shall be forwardly/backwardly inclined curved blade centrifugal type. Impeller shall be double width double inlet type. Fans shall be preferably low rpm (≤ 1500) to minimize vibration and noise. Noise shall be within 85 dB(A) at 1 metre distance from AHU casing. Max. Vibration level shall be acceptance and norms to be specified. Two to three wheels (impellers) shall be provided for each AHU. Impeller blades shall be fabricated from (min. 1.0 mm) galvanized/ epoxy powder coated sheet steel. Fan shall be of epoxy powder coated / galvanized sheet steel (min. 1.6



TECHNICAL SPECIFICATION

AIR HANDLING UNITS

SPECIFICATION NO.PES-553-02

VOLUME II B

SECTION D

REV. 02

DATE: 17.09.2012

SHEET 3 OF 6

mm) scroll with die formed inlets for uniform air flow. Fan shafts shall be solid cold rolled carbon steel (EN8 normalised), ground and polished. Fan shaft bearings shall be of heavy duty type selected for average operating life of 100,00 hours. Bearings shall be self-aligning, permanently lubricated type. Make of Brgs(SKF/FAG/NORMA/TATA) to be specified. Bearing Housing shall be of casting of min. IS Gr. 210, split type and suitably supported. The V-belt drive with belt guard shall be provided. Motors shall have minimum 15% margin over maximum BHP in working range.

3.3 DX or chilled water cooling coils and steam/hot water coils shall be internally corrugated copper/ cupronickel tubes (as per manufacturer's standard) with smooth non corrugated external fins of aluminium (thickness 0.14 mm and grade 1100 as per spec) unless specified otherwise in specification. At least 5 fins /per cm. shall be provided. The chilled water/hot water coils shall have suitable (standardize class, size, threading) drain and vent connections.

3.4 The filters in the filter section shall be provided as detailed in data sheet A.

3.5 Humidifier shall be Pan type/as specified in the specification.

Pan type Humidifier consisting of SS304/316 tank, heater, geyserstat with piping connection to supply air duct shall be provided unless specified otherwise in data sheet A.

Heaters and branch line shall be of galvanized steel and nozzles shall be of brass (matl. grade) /SS 304.

3.6 Condenser water from coil or surplus water from spray humidifier shall be collected in 16 gauge SS-304 pan. Minimum 50mm dia GI pipe nipple shall be provided on each end for drain connection. The drains for these points shall be extended to the main drain in AHU room. Condensate drain pipe (GI) of required length with sealing loop shall be provided and insulated as specified in the specification for insulation. Minimum requirement For GI Pipes and fittings shall be ERW/Seamless of medium thickness as per IS-1239/3589 and Hot dip galvanized

3.7 Suitable number of Spring type vibration isolators shall be provided for fan and motor assembly. Neoprene rubber pads shall be provided below the AHU.

The AHU shall be provided with 18 G SS drain pan.



TECHNICAL SPECIFICATION

AIR HANDLING UNITS

SPECIFICATION NO.PES-553-02

VOLUME II B

SECTION D

REV. 02

DATE: 17.09.2012

SHEET 4 OF 6

4.

TESTING AND INSPECTION AT MANUFACTURERS WORKS:

List of TCs arranged as per Approved Quality Plan shall be furnished along with copy of TCs at the time of inspection.

**TECHNICAL SPECIFICATION****AIR HANDLING UNITS**

SPECIFICATION NO.PES-553-02

VOLUME II B

SECTION D

REV. 02

DATE: 17.09.2012

SHEET 5 OF 6

- 4.1 Visual inspection of GI sheets and angles, channels etc. – dents, black spots, chipping of zinc coating, white dust on galvanised sheets shall be avoided. Pitting, lamination in angles and channels shall be avoided.
- 4.2 Galvanised sheets - Test certificate shall be furnished for visual check, coating thickness, adhesion test, sheet thickness, uniformity of coating. For pipes and fittings compliance report shall be furnished by Manufacturer for visual check, coating thickness, adhesion test, sheet thickness, uniformity of coating.
- 4.3 Shaft: Mechanical and chemical.
- 4.4 Motors (of approved make): Routine TC.
- 4.5 Workmanship and dimensional check as per manufacturing drg. and approved Drgs.
- 4.6 Balancing of impellers- Dynamic balancing certificates shall be furnished –grade 6.3 or better to ISO-1940. Balancing weights shall be positively locked to avoid loosening. Balancing weights and fasteners used shall be galvanized.
- 4.7 Performance test of one Centrifugal fan/per type/per size as per AMCA standard (for indigenous make).
- 4.8 Centrifugal fans for AHUs will be 100% run tested by main contractor of BHEL. One centrifugal fan/per type/per size will be run tested. Vibration shall be within good zone of VDI 2056 / ISO 10816-1(group- K) machines when measured on bearing housing and noise level <85 dbA at 1 metre distance. Max. Temp. on bearing housing- 40 degrees Centigrade + ambient.
- 4.9 Complete assembly of one AHU/per type/ per size (excluding cooling coil and filter) shall be witnessed.
- 4.10 Run test of one complete assembly/per type/per size (excluding cooling coil and filter). Vibration shall be within satisfactory zone of VDI 2056 / ISO 10816-1(group- K) machines when measured on bearing housing and noise level <85 dbA at 1 metre distance. Max. Temp. on bearing housing- 40 degrees Centigrade + ambient.



TECHNICAL SPECIFICATION

AIR HANDLING UNITS

SPECIFICATION NO.PES-553-02

VOLUME II B

SECTION D

REV. 02

DATE: 17.09.2012

SHEET 6 OF 6

5. DRAWINGS/DOCUMENT/DATA REQUIRED AFTER AWARD OF CONTRACT

- 5.1 GA drawing of AHU & data- sheet to be submitted along with technical schedules enclosed in Volume III.
- 5.2 Drawing including equipment layout, foundation & loading details etc. for civil works. These drawings must cover sufficient details so that design of civil works can be completed.
- 5.3 Inspection, operation & Maintenance Manuals.
- 5.4 Equipment description giving complete design calculations, basis of design, selection criteria etc.
- 5.5 Test Certificates.
- 5.6 Final as built documentation i.e. final-version of all drawings, data & information as per the requirement specified elsewhere.
- 5.7 Performance Test Certificates.

**AIR HANDLING UNIT****DATA SHEET - A**

VOLUME - II-B

SECTION - D

REV 00

DATE 17.09.2012

SHEET 1 OF 2

DESCRIPTION**DATA**

- | | |
|--|--|
| 1. Nos. required/working | : Refer to Section-C of Specific technical requirement. |
| 2. Location | : Refer to Section-C of Specific technical requirement. |
| 3. Service/type | : Air Conditioning /Double skin. |
| 4. Fan type | : Centrifugal (forward/backward curve Blade) limit load. |
| a) Capacity | : To Suit as per calculation. |
| b) Static pressure | : To suit but not less than 60 mm wc for AHU's Micro-V filters. |
| c) Discharge direction | : To suit layout. |
| d) Motor | : By Bidder, |
| e) Local push button station (Start/Stop) | : By Others |
| f) Motor location | : Inside AHU Casing. |
| g) Drive | : Belt, pulley, belt guard. |
| 5. Face and Bypass Damper | : Required (Opposed blade type) DX AHU's having |
| 6. Cooling coil | |
| a) Duty sensible heat | : To suit as per calculations |
| b) Duty latent heat | : -do- |
| c) Type of coil | : Chilled Water/DX/Hot Water. |
| d) No. of rows | : To suit but not less than four (4) |
| e) Material of tube /Thickness | : Seamless Copper to ASTM E-75/Equivalent. |
| f) Material of fins | : Aluminium to SAE-1100-/1145-0 |
| g) Number of fins | : Not greater than 5 per cm (13 per inch). |
| h) Max. face velocity | : 2.5 m/sec. |
| i) Air flow quantity | : To suit as per tender drawings/documents. |
| 7. 3 - way motorised mixing valve with thermostat. | : Required with thermostat & actuator for chilled water system for each AHU. |



AIR HANDLING UNIT
DATA SHEET - A

VOLUME - II-B

SECTION - D

REV 00

DATE 17.09.2012

SHEET 2 OF 2

8. Damper at discharge : Manually operated at discharge of each AHU outlet.
a) Material of construction : Mild Steel, galvanised.
9. Filters (Pre-filters)
a) Type & thickness : Dry panel type/ 50 mm
b) Filter area. : To suit as per velocity requirements. "V" - Bank.
c) Filter efficiency : Average arrestance efficiency of 65-80 %
d) Press drop (Clean) : Not to exceed 2.5 mmwc when clean & 6.5 mmwc while dirty.
10. Humidification section : As per the System requirement.
a) Type : Pan type, unless otherwise specified.
b) Operation : Automatic with Humidification.
11. Fresh air arrangement : Required.
a) Fresh air fan : Tube axial flow fans with motor.
b) Accessories : i) Inlet cone with Bird screen.
: ii) Dry panel pre-filters,
: iii) High efficiency filters for control room areas.
: iv) Volume Control Dampers,
: v) Supports etc.
12. Vibration isolator required. : Yes
13. Type of vibration isolator. : Neoprene ribbed Rubber for AHU's.
14. Any other requirement : i) In addition to dry panel filters on AHU, High efficiency filters(average arrestance efficiency of 80-90 %) shall be provided in supply air duct side of AHU for all control room and allied areas.
: ii) Bidder to also provide suitable electrical strip heaters for winter heating & monsoon reheating with Contactor box etc. Heaters to be interlocked with airstat.
15. Instrument & controls : Lot.(including Control box for strip heaters, pan humidifiers etc. in each AHU room.)
16. Insulation of drain piping : Lot.



TECHNICAL SPECIFICATION
LOW PRESSURE AIR DISTRIBUTION
SYSTEM

SPECIFICATION NO.PES-553-07

VOLUME II B

SECTION D

REV. 02

DATE: 17.09.2012

SHEET 1 OF 9

STANDARD TECHNICAL SPECIFICATION
FOR
LOW PRESSURE AIR DISTRIBUTION SYSTEM



TECHNICAL SPECIFICATION
LOW PRESSURE AIR DISTRIBUTION SYSTEM

SPECIFICATION NO.PES-553-07

VOLUME II B

SECTION D

REV. 02

DATE: 17.09.2012

SHEET 2 OF 9

1. GENERAL

1.1 This specification covers the design, manufacture, construction features, installation, inspection testing and air balancing of air distribution system upto a total pressure of 95mm w.g. The specification is intended to cover the air distribution for air conditioning system and ventilation system not involving localised exhaust.

2. CODES AND STANDARDS

2.1 The design, construction and performance of complete system shall conform to all currently applicable statutes, regulations, safety codes in the locality where the equipment are to installed

2.2 Unless specified otherwise the equipments shall generally conform to latest applicable Indian Standards. Nothing in this specification shall be construed to relieve the vendor of this responsibility. In particular the equipment shall generally conform to latest editions by the following standards:-

- a) IS: 655 - Specifications for metal air ducts.
- b) IS:277 - Specifications for galvanised steel sheets.
- c) IS:737 - Specification for wrought aluminium and aluminium alloy sheet and strip.

3. MATERIAL

3.1 Metal air ducts shall be either of galvanised steel sheets or aluminium sheets, as indicated in data sheet-A.

3.2 The rolled steel sheets before galvanising shall be properly annealed or normalised so as to allow fabrication of ducts without developing cracks. Zinc coating on the steel shall be as per technical requirement refer to Section-C of Specific Technical Requirements.

3.3 The aluminium sheets shall be of grade S1C or NS3 and shall be suitable for duct fabrication work as per IS-737 latest

4. CONSTRUCTION/FABRICATION

4.1 The thickness of sheets, the type of bracing and other fabrication details shall generally conform to requirements given hereunder unless specified otherwise in data sheet A and/or indicated on drawings.

4.2 RECTANGULAR DUCTS

4.2.1

S.No.	Max Side	Sheet Thickness	Type of transverse	Bracings
-------	----------	-----------------	--------------------	----------



TECHNICAL SPECIFICATION
LOW PRESSURE AIR DISTRIBUTION SYSTEM

SPECIFICATION NO.PES-553-07

VOLUME II B

SECTION D

REV. 02

DATE: 17.09.2012

SHEET 3 OF 9

		(mm) GI	(mm) AI	Joint connections	
a)	Up to 600	0.63 (24G)	0.80	S-drive, pocket or bar slips or flanged joints on 2.5m centres	None
b)	601 to 750	0.63 (24G)	0.80	S-drive, 25mm pocket or 25mm bar slips or flanged joints on 2.5m centres	25x25x3 mm MS angles, 1.2m from joints
c)	751 to 1000	0.80 (22G)	1.00	S-drive, 25mm pocket or 25mm bar slips or flanged joints on 2.5m centres	25x25x3 mm MS angles, 1.2m from joints
d)	1001 to 1500	0.80 (22G)	1.00	40x40x3mm MS angle, flanged connections or 40mm pocket or 40mm bar slips with 35x3mm bar reinforcing on 2.5m centres	40x40x3 mm MS angles, 1.2m from joints
e)	1501 to 2250	1.00 (20G)	1.50	40x40x3mm MS angle, flanged connections or 40mm pocket or 40mm bar slips, 1M maximum centres, with 35x3mm bar reinforcing	40x40x3 mm diagonal angles or 40x40x3mm angles, 600mm from joints
f)	2251 & above	1.25 (18G)	1.80	50x50x3mm MS angles, connections or 40mm pocket or 40 mm bar slips, 1M maximum centres with 35x3mm bar reinforcing.	50x50x3mm diagonal angles or 50x50x3mm angles 600 mm from joints.
g)	No bracing is required if transverse joints are less than 600mm apart				
h)	For ducts larger than 2250mm, special handling and supporting methods shall be provided as per the approval of Purchaser				

- 4.2.2 All rectangular ducts having either dimension larger than 450mm shall be cross broken except these ducts which are insulated with sand cement plaster. Air outlet connections on ducts need not be cross broken.
- 4.2.3 The seams on duct cones shall be of Pittsburgh type. Longitudinal seams shall be smooth inside the ducts.
- 4.2.4 The flanges used for transverse joints shall be joined together with GI bolts (grade 4.6) and nuts spaced at 125mm centres as per following:
- a) Upto 1000mm - 6 mm dia GI bolts
 - b) 1001 to 1500 - 8 mm dia GI bolts
 - c) 1501 and above - 10mm dia GI bolts



TECHNICAL SPECIFICATION
LOW PRESSURE AIR DISTRIBUTION SYSTEM

SPECIFICATION NO. PES-553-07

VOLUME II B

SECTION D

REV. 02

DATE: 17.09.2012

SHEET 4 OF 9

4.2.5 The MS angle flanges shall be connected to ducts with rivets at approx. 100mm centres. The flanged joints shall have 6mm thick felt packing stuck to flanges with shellac varnish. The holes in the felt packing shall be burnt through. The ducts are to be tapped 6mm across the MS flanges.

4.2.6 MS angles used for bracings shall be tack welded to the ducts or rivetted at 125mm centres, as applicable.

4.3 ROUND DUCTS

4.3.1

S.No.	Duct dia-mm	Sheet Thickness		Reinforcing
		(mm)	(mm)	
		GI	Al	
a)	Up to 150	0.63 (24G)	0.80	None
b)	151 to 600	0.80 (22G)	1.00	None
c)	601 to 1000	1.00 (20G)	1.50	40x40x3mm girth MS
d)	1001 to 1250	1.00 (20G)	1.50	40x40x3mm girth MS angles at 2.0 meter centres
e)	1251 & above	1.25 (18G)	1.80	40x40x3mm girth MS angles at 1.2m centres

4.3.2 The seams on round ducts may be continuously welded or grooved longitudinal seam. In case of welding of GI sheet, zinc rich paint shall be applied on the welded zone.

4.3.3 Round ducts shall either be joined by welding or the ducts shall be swedged 40mm from the ends such that larger end will butt against the swedge and is held in place with sheet metal screws.

4.4 DUCT SUPPORTS

Unless specified otherwise on drawings, rectangular ducts with larger side of 2250mm or above shall be supported by 15mm MS rods and 50x50x3mm and MS angles while those below 2250 mm shall be supported by 10mm MS rods and all angles shall be given a coat of primer paint. The duct supports shall be at a distance not exceeding 1800mm. The MS rods shall be fixed to MS angle cleats, which in turn are fixed to ceiling slab by suitable anchor fasteners. All anchor fasteners, MS angle cleats, coach screws, hooks and other supporting material required shall be provided by vendor.

However, If ducts are thermally insulated, the MS angles and supports shall not be in



TECHNICAL SPECIFICATION
LOW PRESSURE AIR DISTRIBUTION SYSTEM

SPECIFICATION NO.PES-553-07

VOLUME II B

SECTION D

REV. 02

DATE: 17.09.2012

SHEET 5 OF 9

direct contact with ducts, for which purpose wooden pieces/ Resin bonded fibre glass sheets (50 mm thick) shall be used in between.

4.5 FLEXIBLE CONNECTIONS

Wherever the sheet metal ducts connects to intake or discharge of fan units a flexible connection of at least 150mm width made by closely woven double layer Fire resistant or canvas shall be provided. The same shall be attached to angle iron frames on equipment and to similar frame on duct or casing by means of a steel band 9r (or) collar fitting over the end of the flexible connection and bolted through angle iron frame so as to clamp securely between the band and the angle frame.

4.6 TRANSFORMATIONS AND BREACHES

All curves, bends, offsets and other transformations shall be made for easy and noiseless flow of air. The throat of every branch duct shall be sized to have a velocity not exceeding that in the main duct to which the branch is connected.

4.7 CAULKING

Wherever duct passes through wall, the opening between masonry and duct work shall be neatly caulked or sealed to prevent movement of air from one space to adjoin by space with a rated fire resistant material.

4.8 EASEMENT

Normally pipe hangers, light fitting rods etc. shall not be allowed to pass through the ducts. Wherever, It becomes absolutely essential to pass these hangers/rods etc. Through the ducts, prior approval of purchaser shall be taken and light streamlines easement around the same shall be provided to maintain smooth air flow.

4.9 ACCESS DOORS

Access doors shall be provided in ducts, plenums etc. on both sides to allow access and servicing of equipment viz. pipes, dampers, coils, valves, heaters etc.

All access doors shall be adequately sized and lined suitably with felt to prevent air leakage. The doors shall be of built-up construction, structurally strong and shall have at least two hinges each, and shall be with two rust proof window sash locks of approved type. All doors shall be so set as to flush with outer finish of duct insulation etc.

4.10 DAMPERS AND SPLITTERS

4.10.1 Dampers and splitters shall be provided at suitable points for proportional volume control of the system. Splitters and dampers shall be made of minimum 18 gauge GSS of quadrant type with locking device mounted outside the duct at accessible location.

4.10.2 FIRE DAMPERS

Fire dampers shall be provided as specified in Data Sheet -A and shall be installed at locations indicated on drawings and/or as required/approved by purchaser, including all openings in passage of duct work through fire walls and floors etc. The fire damper shall be of electrical type with damper motor actuated by thermal



TECHNICAL SPECIFICATION
LOW PRESSURE AIR DISTRIBUTION SYSTEM

SPECIFICATION NO.PES-553-07

VOLUME II B

SECTION D

REV. 02

DATE: 17.09.2012

SHEET 6 OF 9

sensor or fusible link type.

4.10.3 VANES

Unless otherwise shown in the drawings all elbows shall be such that the throat radius is 75% of the duct width. In case throat radius is smaller, suitable single thickness vanes of approved details shall be provided.

4.10.4 FLASHING

For the ducts penetrating roofs or outside walls, provision of flashing shall be made by the ducting vendor.

4.11 DIFFUSERS AND GRILLS

The type and quantity of diffusers and grills is indicated on enclosed drawings/data sheet A. The size/quantity of diffusers/ grills indicated in the drawing/data sheet is indicative and is for vendor's reference purpose only. Vendor shall ensure that the diffusers/grills offered are of requisite capacity, throw and terminal velocity. The pressure drop and noise levels shall be as per data sheet. A enclosed. The diffusers/grills shall be approved by purchaser.

Unless specified otherwise the diffusers/grills shall be of mild steel and painted with two coats of primer paint. Supply air grills shall be complete with volume control dampers. Supply air grills shall be double deflection type while Return Air grills can be single deflection type. Ceiling outlets/diffusers shall have volume control dampers, fixed grids and blanking baffles. All volume control dampers shall be operated by a key from the front of grills/diffusers.

Suitable vanes shall be provided in duct collars to have uniform air distribution. Blank-off baffles wherever required, shall also be provided.

4.12 PLENUMS AND RA BOXING

All plenum chambers and/or connections to fans, dampers etc. shall be constructed in 18 gauge GI sheet. supported on 40x40x6mm MS angle frames. All vertical angles shall be riveted at approx. 125mm. centres to the casing. Suitable caulking compound (Pecora or equivalent) shall be inserted between the base of the angle and all masonry construction to which angles are fastened.

Return air boxing requirements if any are indicated in data sheet-A and the same shall be provided by vendor. The return air box shall be fabricated out of GI sheets shall be insulated with 25mm thick fibre-glass.

4.13 ACCOUSTIC LINING

The ducts shall be lined acoustically from inside as given in data- sheet A and/or section C of the specification.

4.14 PAINTING

Wherever specified the ducts shall be painted or lined with suitable anti-corrosive paint/ lining as per approval of purchaser. In particular the ducts coming in contact with acid fumes shall be epoxy coated, inside and outside.



TECHNICAL SPECIFICATION
LOW PRESSURE AIR DISTRIBUTION SYSTEM

SPECIFICATION NO.PES-553-07

VOLUME II B

SECTION D

REV. 02

DATE: 17.09.2012

SHEET 7 OF 9

4.15 THERMAL INSULATION

Thermal insulation shall be as per data sheet - A and the insulation shall conform to enclosed spec. no. PES-553-08.

5. INSPECTION AND TESTING

5.1 INSPECTION & TESTING DURING FABRICATION

5.1.1 Visual inspection of GI sheets and angles, channels etc. – dents, black spots, chipping of zinc coating, white dust on galvanised sheets shall be avoided. Pitting, lamination in angles and channels shall be avoided.

5.1.2 Galvanised sheets - Test certificate shall be furnished for visual check, coating thickness, adhesion test, sheet thickness, uniformity of coating.

5.1.3 Check for dimensions & mass as per latest IS-277.

5.1.4 Check for defect, twists, ungalvanised spots as per IS-2629.

5.1.5 Bend test & wrapping test as per IS-277.

5.1.6 Zinc coating test on samples as per IS-6745.

5.2 INSPECTION & TESTING AT SITE.

5.2.1 The duct branches, elbows etc. shall be inspected and the joints and connections etc, are to be checked before they are assembled in position.

5.2.2 After completion, all duct systems shall be checked and tested for air leakage, tightness, velocity, pressure drop, vibration and noise etc.

6. BALANCING

6.1.1 The entire air distribution system shall be balanced by vendor to supply the air quantities as required in various rooms so as to maintain the requisite temperature and air flow in the conditioned spaces. The final balance of air quantities through each grill/diffuser etc. shall be recorded and submitted to purchaser for approval. Proper steps shall be taken to have a uniform temperature in all enclosures, with utmost care for noise level to be within tolerance limit

6.1.2 All instruments required for testing/balancing etc. of the air distribution system shall be provided by vendor.



TECHNICAL SPECIFICATION
LOW PRESSURE AIR DISTRIBUTION
SYSTEM

SPECIFICATION NO.PES-553-07

VOLUME II B

SECTION D

REV. 02

DATE: 17.09.2012

SHEET 8 OF 9

7. DATA TO BE FURNISHED BY VENDOR AFTER THE AWARD OF CONTRACT

- 7.1 Fabrication drawings of ducts and grilles, louvers, dampers, etc, including typical details of grilles dampers etc.
- 7.2 Test certificates in line with scope of inspection.
- 7.3 Other dimensional drawings & documents as may be required by purchaser for better understanding of the system & for preparation of operation, maintenance & instruction manual.



TECHNICAL SPECIFICATION
LOW PRESSURE AIR DISTRIBUTION
SYSTEM

SPECIFICATION NO.PES-553-07

VOLUME II B

SECTION D

REV. 02

DATE: 17.09.2012

SHEET 9 OF 9



LOW PRESSURE AIR DISTRIBUTION SYSTEM

DATA SHEET - A

VOLUME II-B

SECTION D

REV 00

DATE 17.09.2012

SHEET 1 OF 2

Description

Data

- | | |
|--------------------------------|---|
| 1. General (List of areas) | : As per Specification/Tender drawing. |
| 2. GSS Duct Work | |
| a) Type | : GSS as per IS: 277
(Zinc coating as per Section-C of Specific Technical Requirements.) |
| b) Size | : As per Section-C of Specific Technical Requirements and bill of quantity. |
| 3. Acoustic lining | : Up to 5m length from AHU Outlet. |
| 4. Special painting | : Galvanised. |
| 5. Thermal Insulation | : Required in supply air duct in AC entire length. |
| 6. Diffusers (Circular/Square) | |
| 300 mm size | } : Bidder to estimate as per drawings./specification.
All grille frame and louvers shall be manufactured of at least 16 SWG Aluminium |
| 350 mm size | |
| 450 mm size | |
| 550 mm size | |
| 600 mm size | |
| Any other size | |
| 7. SA grilles (for each size) | : To suit air flow as per System requirements / Tender Drawings. |
| 8. RA grilles (for each size) | : -do- |

NOTE:

1. Duct sheet thickness shall be as per IS-655
2. Opposed blade type volume control damper shall be provided at each supply air diffusers/grilles.
3. Bidder to provide suitable gasketing at each duct flange.
4. Fire damper shall be motor operated type, when otherwise specified under Section-C.
5. Access door in ducting system shall be provided as required.
6. MS Angle (painted) shall be used for duct supports etc.
7. Velocity thru duct shall normally not exceed 9.0 M/sec for Air conditioning system. Maximum velocity (outlet) for supply air diffuser shall not exceed 2.5 m/sec.



LOW PRESSURE AIR DISTRIBUTION SYSTEM

DATA SHEET - A

VOLUME II-B

SECTION D

REV 00

DATE 17.09.2012

SHEET 2 OF 2

8. All Grilles & diffusers shall be supported with frame. Frame etc. shall be supplied by bidder.



**TECHNICAL SPECIFICATION
FOR
PACKAGE CONDITIONING UNIT**

SPECIFICATION NO.PES-553-05

VOLUME II B

SECTION D

REV. 02

DATE:17.09.2012

SHEET 1 OF 6

**STANDARD TECHNICAL SPECIFICATION
FOR
PACKAGE CONDITIONING UNIT**



**TECHNICAL SPECIFICATION
FOR
PACKAGE CONDITIONING UNIT**

SPECIFICATION NO.PES-553-05

VOLUME II B

SECTION D

REV. 02

DATE:17.09.2012

SHEET 2 OF 6

1 **GENERAL**

1.1 This specification covers the design, manufacture, inspection and testing at the manufacturer's works and suitable packing delivery and testing of the packaged air conditioning unit.

2 **CODES AND STANDARDS**

2.1 The design, manufacture, inspection, testing and performance of the packaged type air conditioning unit shall comply with all statutes, regulations and safety codes currently applicable in the locality where the equipment will be installed. The equipment shall also conform to the latest editions of the codes and standards specified herein under. Nothing in this specification shall be construed to relieve the vendor of this responsibility.

In particular, the packaged air conditioning Unit (max 7.5 TR capacity, ductable or non ductable type) or cassette type (up to 5 TR) shall conform to the latest editions of the following standards:

2.1.1 I.S.660 : Safety code for Mechanical Refrigeration.

2.1.2 I.S.5111 : Code of practice for measurement, and testing of refrigerant compressor.

2.1.3 I.S.659 : Safety code for air conditioning.

2.1.4 I.S.2494 : V Belt for industrial purpose.

2.1.5 I.S.3142 : V grooved pulleys for V Belts.

2.1.6 I.S.4503 : Shell and tube type heat exchanger.

2.1.7 ARI 210 : Standard for/unitary air conditioning equipment

2.1.8 ARI 270 : Standard for application installation and servicing of unitary equipment.

2.1.9 ASHRAE-37 : Standard methods of testing for rating unitary air conditioning and heat pump / equipment.

2.1.10 ANSI-B9-1 : Safety code for mechanical refrigeration.

3 **DESIGN AND CONSTRUCTIONAL REQUIREMENTS**

3.1 Compressor

The compressor shall be hermetic or semi-hermetic or screw rotary type or scroll type. The same shall be suitable for R410A/R407C/R134A refrigerant. The compressor shall be mounted on anti-vibration spring/rubber pads and shall be positioned in such a way that it is freely accessible with sufficient space all around for easy maintenance. Safety controls like High and Low pressure cut-out overload and single phasing protection for the motors shall be provided. A crankcase heater shall also be provided, if considered necessary by the vendor.

3.2 **CONDENSING UNIT**

Shell and tube type water cooled condenser or air cooled condenser with adequate area shall be provided as specified in Data Sheet-A. The condensing unit shall be complete with



**TECHNICAL SPECIFICATION
FOR
PACKAGE CONDITIONING UNIT**

SPECIFICATION NO.PES-553-05

VOLUME II B

SECTION D

REV. 02

DATE:17.09.2012

SHEET 3 OF 6

multipass heads and shall be fitted with the following:

- 3.2.1 Hot gas inlet and liquid outlet connection with shut off valve for liquid.
- 3.2.2 Drain plug, air vent and test valve.
- 3.2.3 Water inlet and outlet connection with thermowell and suitable cocks respectively.
- 3.2.4 Relief valve and air purge valve (Fusible plug in place of relief valve not acceptable)
- 3.2.5 Any other accessory as recommended by the manufacturer for proper functioning of the equipment.

3.3 AIR HANDLING FAN

The air handling fan shall be of the centrifugal type and with forward curved blades. This shall be driven by means of a three phase induction motor through V belt drive. The fan static pressure shall be selected for passing air through high efficiency absolute filters, if specified in Data Sheet-A.

3.4 FILTERS

Filters shall be of dry panel type and shall be cleanable. The velocity of air across the filters shall not exceed 1.75m/sec (350FPM).

3.5 COOLING COIL

The cooling coil shall be of direct expansion type and shall be made of heavy gauge copper with aluminium fins. The fins shall be bonded to the copper tubes under hydraulic pressure. A distributor shall be provided for feeding the refrigerant to different sections of the coil. Rows shall be staggered in the directions of airflow. The velocity of air across coil shall not exceed 2.5M/Sec. (500 FPM).

3.6 CONTROLS

All necessary controls and accessories like thermostatic expansion valve, refrigerant solenoid valve, distributor, filter drier in the liquid lines, shut off valves, HP/LP cut out for compressor, thermostat with adjustable settings, overload and single phasing preventer for motor etc. are to be provided. The microprocessor based control panel shall be provided outside the packaged unit on one side. The control panel shall generally be in line with the specification for control panels given elsewhere.

The control shall be so interlocked that the fan shall be started independently first, and then only the compressor. Tripping of the compressor by the thermostat or compressor cut outs shall not trip the fan. The thermostat setting shall be adjustable

3.7 REFRIGERANT PIPING

The refrigerant piping shall be either heavy gauge copper as furnished in Data Sheet-A. The piping shall be completely factory assembled, pressure tested, dehydrated and initially charged with FREON gas and compressor oil. The line accessories shall include liquid line shutoff valve dehydrator, strainer, flow indicator and distributor etc.

3.8 CABINET

All the equipments, except control panel, mentioned above shall be provided within a heavy gauge sheet metal cabinet, of floor/ wall mounted type. This shall be given two coats of anti-corrosive and rust proof paint, finished with two coats of final paint . Painting shall be as per manufacturers std unless specified otherwise in data sheet 'A'. The interior of the cabinet shall be provided with thermal and acoustic insulation of minimum 25mm thick. The insulating material shall be fire proof.



**TECHNICAL SPECIFICATION
FOR
PACKAGE CONDITIONING UNIT**

SPECIFICATION NO.PES-553-05

VOLUME II B

SECTION D

REV. 02

DATE:17.09.2012

SHEET 4 OF 6

The front and back side of the cabinets shall be easily removable providing maintenance to all the interior parts.

All the electric wires within the cabinet shall run in flexible conduits and carry identification tags. The bottom side of the panel shall be specially ribbed to take care of the transportation.

3.9 OTHER ACCESSORIES

Each packaged air conditioner shall be provided with required number of neoprene rubber isolating pads.

4 CONTROL AND INTERLOCK REQUIREMENTS

The compressor shall have all protective devices like HP/LP cutouts, overload protection for the motor, single phasing preventor for motor etc.

The interlocking requirement shall be as indicated below:

4.1 The compressor shall not start, unless condenser water flow is achieved for water cooled condenser. The condenser flow shall be sensed by means of a flow switch.

4.2 The compressor shall not start unless the evaporator fan is started.

4.3 The tripping of compressor on HP/LP, overload or on thermostat shall not trip the fan.

4.4 Strip heater (if provided in the ducting system) shall not be switched on, unless the evaporator fan is started and airflow is established. For this purpose, an air stat on flow switch shall be used. The heater shall be separately controlled by humidistat/thermostat

4.5 A humidifying package, if specified in data sheet A, shall be controlled by humidistat.

5 TEST AND INSPECTION

5.1 Inspection and Testing at Manufacturer's Works

5.1.1 static and dynamic test for fans

5.1.2 Hydrostatic static test on condenser and cooling coil.

5.1.3 vacuum/pressure test for the complete refrigeration circuit.

5.1.4 Visual and Free running test of the packaged unit on test bed.

5.1.5 Free running test on compressor.

5.1.6 AIR CAPACITY WITH ANEMOMETER.

5.1.7 NOISE LEVEL- ≤ 85 dB(A).

5.1.8 Other tests as per approved qualities plan/scope of inspection.

5.2 Inspection and Testing at Site

5.2.1 Performance testing of the packaged unit for 72 hours in summer / monsoon & 24-hours in winter- Up-to 3 TR (individual M/c capacity) inside room temperature (Dry & wet bulb) will be checked with all machines in the room operating.

The actual days of testing shall be mutually agreed. During the above testing, the following readings shall be taken to compare the same with guaranteed performance data.

5.2.1.1 Condenser inlet and outlet pressure and temperature

5.2.1.2 Entering and leaving air temperature of the cooling coil air filters.



**TECHNICAL SPECIFICATION
FOR
PACKAGE CONDITIONING UNIT**

SPECIFICATION NO.PES-553-05

VOLUME II B

SECTION D

REV. 02

DATE:17.09.2012

SHEET 5 OF 6

- 5.2.1.3 Motor current for the compressor and blower.
- 5.2.1.4 Air quantity delivered by the fan. This shall be computed by adding air quantity leaving all the grilles entering the air filters.
Room temperature (Dry & wet bulb)
- 5.2.1.5 Test to ensure all controls and safety instruments are working properly.
During the above testing, noise level also will be checked to ensure that the same are within acceptable limits. Any undue vibration detected physically will be corrected.
All tools and instruments required for the above testing will be provided by the vendor.
- 6** **PAINTING:**
The packaged unit shall be given two coats of primer paint finished with two coats of finish paint as per Manufacturers std. unless specified otherwise elsewhere/ Data sheet 'A'. The colour of finish paint will be as specified in Data Sheet-A.
- 7** **GUARANTEES**
The package unit shall be guaranteed for performance measured in terms of the inside temperature maintained.
The packaged unit shall also be free from any manufacturing defects and shall be guaranteed as per contract after the first test as per 5.0 is successfully carried out, and the plant taken over by the purchaser.
- 8** **NAME PLATES**
Suitable Name plate as per Data Sheet 'A', depicting the equipment number as designated in Data Sheet A shall be provided for each packaged unit and screwed to a prominent position on the packaged unit.



**TECHNICAL SPECIFICATION
FOR
PACKAGE CONDITIONING UNIT**

SPECIFICATION NO.PES-553-05

VOLUME II B

SECTION D

REV. 02

DATE:17.09.2012

SHEET 6 OF 6

9. DATA TO BE FURNISHED AFTER AWARD OF CONTRACT

- 9.1 Final technical data as per Data Sheet-B
- 9.2 G.A. and interior view of packaged unit
- 9.3 Electrical wiring diagram
- 9.4 Catalogues for all controls
- 9.5 O & M Manual
- 9.6 Erection Manual



PACKAGE-CONDITIONING UNIT
DATA SHEET - A

VOLUME II-B

SECTION D

REV 00

DATE 17.09.2012

SHEET 1 OF 1

DESCRIPTION

DATA

- | | |
|---|--|
| 1) Capacity of the unit at operating conditions. | : As specified |
| 2) Numbers required | : Refer to Section-C of Specific Technical Requirements |
| 3) Designation of the unit | : Package AC Unit |
| 4) Whether air cooled/water cooled | : Refer to Section-C of Specific Technical Requirements |
| 5) The plant shall be suitable for maximum-
- ambient temp. | : Refer outdoor design condition as specified. |
| 6) Whether a plenum Chamber required | : Units shall be connected to fresh air ducts. |
| OR | |
| Whether to be connected duct system. | : Yes. |
| 7) Whether Humidifier required for humidity-
-control. | : Refer to Section-C of Specific Technical Requirements |
| 8) Whether strip heaters required for winter
heating. | : Refer to Section-C of Specific Technical Requirements |
| 9) Whether strip heater required for Humidity
control. | : Refer to Section-C of Specific Technical Requirements |
| 10) Final painting colour shade
stage. | : Subject to approval / during detail engineering |
| 11) Whether fan static pressure is to be
designed for filters arrangement shown. | : Yes. |
| 12) Installation supporting structure/
drain piping, insulation. | : Required. Drain piping with insulation up to the
nearest drain point. |
| 13) Controls & Instruments | : Yes (Lot) |
| 14) Isolation Switch | : Yes |



**STANDARD TECHNICAL SPECIFICATION
FOR
AIR FILTER**

SPECIFICATION NO.PES-553-06

VOLUME II B

SECTION D

REV. 02 DATE: 17.09.2012

SHEET 1 OF 4

**STANDARD TECHNICAL SPECIFICATION
FOR
AIR FILTER**



**STANDARD TECHNICAL SPECIFICATION
FOR
AIR FILTER**

SPECIFICATION NO.PES-553-06

VOLUME II B

SECTION D

REV. 02

DATE: 17.09.2012

SHEET 2 OF 4

1. GENERAL

This specification covers the design, manufacture, inspection and testing at manufacturer's work or his sub-contractor's works of Air filters to be used for air-conditioning and ventilation system.

2. CODES AND STANDARDS

This design, manufacture and performance of AIR FILTERS shall comply with all currently applicable statutes, regulation and safety codes in the locality where the equipment will be installed. The equipment shall also conform to latest applicable Indian/British/USA standards. Nothing in this specification shall be construed to relieve the vendor of this responsibility. The following standards, in particular, shall be applicable for certified ratings of filters and for conducting performance test, if required.

a) BS EN - 779 -Methods of test for air filters used in air conditioning and general ventilation.

3. GENERAL

The enclosed Data sheet A gives the type and other particulars of filters required.

3.1 POLY FIBRE AIR FILTERS

Filtering media shall consist of a suitable fibrous material (e.g. polyethylene extruded sections coir etc.) packed into a 20 gauges GSS framework, complete with handles etc. The filter element shall be supported by galvanised steel wire mesh of 10mm. sq. on either side, Velocity across the filters shall not exceed 2.5 M/sec. Average efficiency E_m (%) shall be ≥ 80 as per BS EN - 779.

3.2 DRY FABRIC AIR FILTERS

Filter element shall be pressed felt filter fabric or suitable material recommended by the manufacturer, stitched on to galvanised wire gauge support and crimped to form deep folds. Suitable aluminium spacers shall be provided to ensure uniform distribution of air flow through filters. Filter casing shall be provided with neoprene sponge rubber sealing, The filter shall have Average efficiency E_m (%) of ≥ 95 as per BS EN - 779.

3.3 PANEL TYPE METALLIC FILTERS (DRY/VISCOUS)

Filter shall consist of V-fold galvanised wire mesh interspaced with flat layers of galvanised wire mesh. The density of media shall increase in the direction of air flow. Edges of wire mesh shall be suitably hemmed to prevent abrasion during handling. The media shall be supported on either side by galvanised expanded metal casing. The framework shall be at least 18 gauge GSS. Filter shall be either dry or wetted type as per data sheet=A. The oil shall be mineral oil of approved quality and make. As a the filter frame made of Aluminium alloy conforming to IS:737 can be considered unless use of aluminium is prohibited otherwise due to site conditions being saline/corrosive.

All filters shall be capable of being cleaned of their accumulated dust by tap water flushing. The dry metallic filter shall have Average arrestance A_m (%) shall be ≥ 90 .



**STANDARD TECHNICAL SPECIFICATION
FOR
AIR FILTER**

SPECIFICATION NO.PES-553-06

VOLUME II B

SECTION D

REV. 02

DATE: 17.09.2012

SHEET 3 OF 4

However oil wetted air filters shall have Average Efficiency E_m (%) \geq 90 as per BS EN - 779..

3.4 AUTOMATIC CLEANING FILTERS

This shall consist of a filter mat and drop eliminator, driven by a suitably rated geared motor unit being supported on a steel framework. The filter mat shall consist of an endless steel wire mat insets of steel mesh held between an upper & a lower shall drop eliminator shall consist of an endless steel wire without insets of steel mesh. The unit shall include a suitable oil pump, gludge raking mechanism and sludge container and tensioning device. Pressure drop shall be limited to 0.5 / mm WG when clean & 10 mm when dirty. Air velocity across filter shall not exceed 3 M/sec.

3.5 ABSOLUTE FILTERS

Filters shall be constructed by pleating a continuous sheet of filter medium into closely spaced pleats separated by heavy corrugated aluminium spacers. They shall be individually tested and certified to have an efficiency of not less than 99.97% when tested with 0.3 micron dioctylphalate smoke as per IS:2831. The clean filter initial static pressure drop shall not be greater than 25mm WC at rated capacity. A neoprene sponge rubber sealing shall be provided on either face of filter frame.

3.6 WATER REPELLANT NYLON FILTERS

This shall be constructed of water repellent nylon fabric with continuous water spraying on it from a header for keeping it clean. Efficiency of this filter shall be 85% down to 10 microns. This filter shall be used for unitary air filtration system only.

4. INSPECTION & TESTING

The scope of inspection for air filters shall be as below:

4.1 Dimensional inspection of frame & filter media.

4.2 Witnessing of type tests on one per type per size air filters for the following properties.

- a) Gravimetric efficiency.
- b) Pressure drop in clean & dirty (choked - %age to be specified) condition.
- c) Efficiency as per BS EN - 779.

4.3 Verification of type test certificates for similar type & size of filters for sodium flame test as per BS-3928 (if applicable- refer data sheet).



**STANDARD TECHNICAL SPECIFICATION
FOR
AIR FILTER**

SPECIFICATION NO.PES-553-06

VOLUME II B

SECTION D

REV. 02

DATE: 17.09.2012

SHEET 4 OF 4

5. DATA TO BE FURNISHED BY VENDOR AFTER AWARD OF CONTRACT

- 5.1 GA Drawing.
- 5.2 Drawing showing material/construction detail
- 5.3 Installation and\service manual
- 5.4 Rating curves/charts
- 5.5 Test certificates
- 5.6 Elect. diagrams (when automatic cleaning type)



AIR FILTER
DATA SHEET - A

VOLUME II-B

SECTION D

REV 00

DATE 17.09.2012

SHEET 1 OF 1

DESCRIPTION

DATA

1) General

- | | |
|------------------------------|--|
| 1.1 Service | : Air Conditioning. |
| 1.2 Location | : Central Air conditioning plant, & package AC plant, fresh air fan system. Also for split AC. |
| 1.3 Nos. | : Refer Section 'C' of Specification. |
| 1.4 Total air flow/type | : Refer Section 'C' of Specification. |
| 1.5 Temperature | : As per project information. |
| 1.6 Relative Humidity | : 100% |
| 1.7 Gas Composition | : Atmospheric Air (Dusty) as prevalent in power Station. |
| 1.8 Filter Media | : Synthetic non-woven |
| 1.9 Efficiency | : Average arrestance efficiency of 65-80 % for Dry Panel filter (pre-filters) and average arrestance Efficiency of 80-90 % for fine filters. |
| 1.10 Allowable pressure drop | : 2.5 mm & 6.5 mm in clean and dirty condition respectively for dry panel filters(prefilters).
12 mm in clean condition for fine filters. |
| 1.11 Frame Work | : 18 G, GSS. |
| 1.12 Mounting | : Ladder Type M.S Angles (galvanised) |
| 1.13 Size | : 600 x 600 mm |

Note:-

- 1) Face velocity of air across the filters shall not exceed 2.5 m/sec.



TECHNICAL SPECIFICATION
THERMAL INSULATION FOR COLD SURFACES

SPECIFICATION NO.PES-553-08

VOLUME II B

SECTION D

REV. 02

DATE: 17.09.2012

SHEET 1 OF 6

**STANDARD TECHNICAL SPECIFICATION
FOR
THERMAL INSULATION FOR COLD SURFACES**



TECHNICAL SPECIFICATION
THERMAL INSULATION FOR COLD SURFACES

SPECIFICATION NO.PES-553-08

VOLUME II B

SECTION D

REV. 02

DATE: 17.09.2012

SHEET 2 OF 6

1.

SCOPE

This specification covers design, manufacture, testing at manufacturers works, supply, application & finishing of insulation for cold piping, air conditioning ducting & equipment for low temperature service.

2.

CODES & STANDARDS

The design, manufacture and performance of materials covered under this specification shall comply with all currently applicable statues, regulations & safety codes in the locality where the equipment/material are to be installed. The material shall also conform to the latest applicable Indian/British/American codes & standards. Nothing in this specification shall be construed to relieve the vendor of his responsibility. In particular, the material shall conform to the latest editions of the following standards :-

IS:3069: GLOSSARY OF TERMS & SYMBOLS & UNITS RELATING TO THERMAL INSULATION

materials.

2.1

IS:4671 : Expanded polystyrene for thermal insulation purposes.

2.2

IS:3677 : Mineral wool for thermal insulation.

2.3

IS:8183 : Resin bonded mineral wool.

3.

DESIGN REQUIREMENTS

3.1

The insulating material as well as protective covering shall be new & unused, non-corrosive, vermin/rodent proof and shall be guaranteed to withstand continuously & without deterioration the maximum/minimum temperatures to which they may be subjected to, under specified site conditions.

3.2

The insulation material must be light weight, strong, free from shots & coarse fibre & shall provide high insulation efficiency at low weight & coat. It should be non-hygroscopic & should not rot. It shall not settle or shake down even when subjected to prolonged vibrations.

3.3

The insulation material, density and thickness etc. Shall be as specified in DATA SHEET A.

4.

APPLICATION DETAILS

4.1

The surface to be insulated shall be thoroughly cleaned and allowed to dry. Pressure/hydrostatic tests, if any, shall be carried out before application of insulation.

4.2

A layer of solvent free, anticorrosive paint shall be applied & allowed to dry.

4.3

Hot industrial bitumen of grade 85/40 or 85/25 conforming to latest IS:702 shall be uniformly applied @ 1.5 kg/sq.m on the surface to be insulated. A similar layer shall also be applied on the inside surface & edges of the insulation. A suitable cold adhesive compound may also be used in place of bitumen.

4.4

Insulation in the form of pipe sections/rolls slabs of specified density & thickness shall be stuck to the coated surface with joints staggered & well butted & secured. The adjoining sections shall be tightly pressed together. All the joints shall be sealed with



TECHNICAL SPECIFICATION
THERMAL INSULATION FOR COLD SURFACES

SPECIFICATION NO.PES-553-08

VOLUME II B

SECTION D

REV. 02

DATE: 17.09.2012

SHEET 3 OF 6

bitumen/equivalent adhesive. Voids if any shall be packed with suitably cut pieces of insulation material.

- 4.5 In case of double layer application both circumferential & longitudinal joints shall be suitably staggered.

5. VAPOR SEALING & INSULATION FINISH

The insulation shall be treated for vapor sealing & weather proofing & finished as specified in DATA SHEET A The acceptable types of finishes are outlined below:-

5.1 FINISHING SYSTEM I: EXTERNAL INSULATION WITH PLASTER FINISH

- 5.1.1 A thick vapor seal of hot bitumen @ 2.5 kg/Sqm shall be applied on the outer surface of insulation & allowed to dry.

- 5.1.2 The surface shall then be wrapped with 20mm (3/4") hexagonal mesh of 24 SWG GI wire, butting all the joints & laced down with 22 SWG GI lacing wire.

- 5.1.3 12.5mm (1/2 inch) thick sand cement plaster in the ratio of (1:1) shall be applied in two layers, the second layer being brought to a smooth finish. A water proofing compound shall be added to the cement before its application.

5.2 FINISH SYSTEM II: EXTERNAL INSULATION WITH PLASTER FINISH OVER POLYTHENE.

- 5.2.1 The insulation shall be covered with 500 g polythene/polythene bonded Hessians (PBH) with 50mm overlap on longitudinal & circumferential joints. Overlaps shall be sealed with synthetic adhesive in case of polythene & liberal coat of bitumen in case of PBH:

- 5.2.2 The surface shall then be wrapped with 20mm (3/4") mesh of 24 SWG GI wire butting all the joints & laced down with 22 SWG GI lacing wire.

- 5.2.3 12.5mm thick (1/2 inch) sand cement plaster in ratio of(4:1) shall be applied in two layers, the second layer being brought to a smooth & even finish similarly as described above.

5.3 FINISH III:EXTERNAL INSULATION WITH SHEET METAL FINISH

- 5.3.1 The insulation shall be covered with 500g polythene with 50mm overlaps at joints which shall be sealed with synthetic adhesive or equivalent compound.

- 5.3.2 The polythene shall be covered with 24 gauge GI/aluminum sheet

- 5.3.3 25mm wide x 22 SWG GI/aluminum peripheral straps shall be fixed over the GI/aluminum sheet at 300mm centres to secure.

5.4 FINISH IV: EXTERNAL INSULATION WITH PLASTER & WATER PROOFING COMPOUND

For ducts & piping exposed to atmosphere, the finish shall be as follows:

- 5.4.1 A thick vapor seal of hot bitumen at 2.05 kg/sq.m shall be applied on the outer surface of insulation & allowed to dry.

- 5.4.2 The surface shall then be wrapped with 20mm (3/4") hexagonal mesh of 24 SWG GI Wire butting all the joints & laced down with 22 SWG GI lacing wire.

- 5.4.3 12.5mm thick (1/2 inch) sand cement plaster in ratio of (4:1) shall be applied in two layers, the second layer being brought to a smooth finish with water proofing compound added to the cement.



TECHNICAL SPECIFICATION
THERMAL INSULATION FOR COLD SURFACES

SPECIFICATION NO.PES-553-08

VOLUME II B

SECTION D

REV. 02

DATE: 17.09.2012

SHEET 4 OF 6

5.4.4

3 mm (1/8") thick coat of water proofing compound shall be applied & wrapped with fibre glass RP tissue. A final coat of 3mm thick water RP proofing compound shall then be applied over the fiberglass RP tissue & allowed to dry. Alternatively, in place of water proofing as desired above, tar felt type 3 grade 1 of IS 1322 with joints overlapped by 75mm shall be fixed & sealed with bitumen & over this 24 SWG. 25mm hexagonal GI mesh shall be fixed with 22 swig. GI lacing wire & finally bitumen paint shall be applied over wire netting.



TECHNICAL SPECIFICATION
THERMAL INSULATION FOR COLD SURFACES

SPECIFICATION NO.PES-553-08

VOLUME II B

SECTION D

REV. 02

DATE: 17.09.2012

SHEET 5 OF 6

6. INSULATION OF PUMPS & VALVES

6.1 For all inspection covers & hatches on equipment, pump casing & valve bodies, flanges etc. the insulation shall be applied such as to facilitate removal with minimum damage to the insulation. This shall be achieved by encasing the insulation in 22 gauge aluminum sheet metal boxes, which shall be bolted together around the equipment to permit easy removal & replacement. Proper care shall be taken to maintain continuity of vapor seal between the static & removable partitions of the insulation.

6.2 The tenderer may offer thickness of insulation & finishes other than that specified in DATA SHEET A. However, calculations/reasons in support of alternative proposal shall be furnished for purchaser's approval.

7. INSPECTION & TESTING (REFER SPEC. NO - PES-553.00)

7.1 All necessary tests, as required to ensure that the material supplied conform to the requirements of applicable codes & standards, shall be carried out at manufacturer's works & test certificates including these for material/accessories shall be furnished for purchaser's approval.

8. PAINING

8.1 Pipe work having insulation & cladding shall be provided with color identification for the fluids handled and for indicating direction of flow.

8.2 Equipment surfaces having insulation and cladding shall also have identification numbers and any other relevant data provided on the insulated surface.

8.3 All painting for insulated surfaces shall conform to the requirement specified elsewhere.



TECHNICAL SPECIFICATION
THERMAL INSULATION FOR COLD SURFACES

SPECIFICATION NO.PES-553-08

VOLUME II B

SECTION D

REV. 02

DATE: 17.09.2012

SHEET 6 OF 6

9. DATA TO BE FURNISHED AFTER AWARD OF CONTRACT

- 9.1 Final version of data sheet 'B' incorporating changes if any along with design data.
- 9.2 Test certificates/reports giving result of insulation to ensure conformance to applicable codes & standards & in particular the following:-
- a) Thermal conductivity test.
 - b) Sound absorption coefficient test.
 - c) Corrosion test.
 - d) Sulphur content, moisture content, shot content, moisture absorption etc.
 - e) Compressive strength & cross breaking strength test.
- 9.3 Sketches/technical literature/sectional drgs. indicating insulation materials finish and method of application etc.
- 9.4 Manual dealing with safety aspects & instructions for combating fire arising out of insulation work.
- 9.5 Instructions on maintenance of insulation work.



THERMAL INSULATION
FOR COLD SURFACE
DATA SHEET - A

VOLUME II-B

SECTION D

REV 00

DATE 17.09.2012

SHEET 1 OF 1

Insulation Material

Insulation	Code	Thermal Conductivity MW/cm ⁰ C	Density Kg/m ³
Resin bonded mineral wool / glass wool	IS:8183	0.49 at 50 ⁰ C	At least 24 for duct insulation and 48 for acoustic lining.
Mineral Wool Pipe Section (min. Gr.2)	IS:9842	0.43 at 50 ⁰ C	At least 81
Expanded Polystyrene	IS:4671	0.37 at 10 ⁰ C	At least 15

Type of Insulation

S.No.	Surface	Insulation Material	Insulation Form	Thickness (mm)
i)	Supply & Return air duct for air-conditioning system	Resin bonded roll Mineral Wool (IS:8183)		25
ii)	Refrigerant Piping	a) Expanded Polystyrene	Pipe Section	75
		or		
		b) Mineral Wool	Pipe Section	75
iii)	AHU drain pipe	a) Expanded Polystyrene	Pipe Section	25
		or		
		b) Mineral Wool	Pipe Section	25
iv)	AHU drain pan coil section and fan section	a) Expanded Polystyrene	Slabs	25
		or		
		b) Mineral Wool	Slabs	25
v)	Chilled water piping, valves & specialties	a) Expanded Polystyrene	Pipe Section	75
		or		
		b) Mineral Wool	Pipe Section	75
vi)	Chiller	a) Expanded Polystyrene	Slabs	100
		or		
		b) Mineral Wool	Slabs	100
vii)	Chilled Water Pumps	a) Expanded Polystyrene	Slabs	50
		or		
		b) Mineral Wool	Slabs	50
viii)	Expansion tank with pipe	a) Expanded Polystyrene	Slabs/Pipe Section	50
		or		
		b) Mineral Wool	Slabs/Pipe Section	50



**STANDARD TECHNICAL SPECIFICATION
FOR
AIR WASHER**

SPECIFICATION NO.PES-554-01

VOLUME II B

SECTION D

REV. 00 DATE: NOV 2012

SHEET 1 OF 3

**STANDARD TECHNICAL SPECIFICATION
FOR
AIR WASHER**



**STANDARD TECHNICAL SPECIFICATION
FOR
AIR WASHER**

SPECIFICATION NO.PES-554-01

VOLUME II B

SECTION D

REV. 00

DATE: NOV 2012

SHEET 2 OF 3

1. GENERAL

1.1.1 This specification covers the design, manufacture, construction features, installation, commissioning and conducting performance test at site.

2. CODES AND STANDARDS

The design/manufacture and performance of air washer shall comply with all currently applicable statutes, regulations and safety codes in the locality where the air washer is installed. The equipments shall also conform to the requirements of the latest editions of applicable Indian/British/US standards. Nothing in this specification shall be construed to relieve the vendor of this responsibility. In particular the equipments shall conform to the latest editions of the following standards:-

2.1.1 IS:277: Galvanised steel sheets

2.1.2 IS:1239: Mild steel tubes

2.1.3 IS: 2062:

3. DESIGN/CONSTRUCTION FEATURES

3.1 GENERAL

3.1.1 The air washer shall be designed for max. air velocity of 2.8M/sec. Circulating water quantity shall be 1.0 CMH for every 1000 CMH of air flow, unless otherwise stated in data sheet A. The minimum saturating efficiency of air washer shall not be less than 90% Minimum length of air washer shall be 2500 mm.

3.2 TANK (SUMP)

3.2.1 The air washer tank shall either be masonry or metallic construction as specified in data sheet A. Masonry tank shall be provided by purchaser whereas metallic tank shall be of welded construction, fabricated from not less than 6mm thick MS plates, and inside, outside surfaces shall be provided with anti corrosive paint (Zinc sprayed to coating thickness of 75 micron min.).

3.2.2 The air washer tank shall have a minimum depth of 600mm and tank construction shall be such that the suction screen can be replaced while the air washer is under operation. The inlet and outlet ends of tank shall be suitably constructed to accommodate distribution plates and eliminator plates.

3.3 DISTRIBUTION PLATE

3.3.1 The distribution plate shall be fabricated from minimum 18 gauge thick GSS and shall have minimum 50% free area. The angles used for supports shall be galvanised.

3.3.2 The distribution plate shall be built up of number of sections for easy handling.

3.4 HEADERS AND STAND PIPE

3.4.1 The air washer shall be of two bank construction (one cross flow and other unit flow). The piping up to and including 100mm dia meter shall be of galvanised steel and above 100mm dia shall be black steel (subsequently spray galvanized to coating thickness as per approved TDS). All piping shall be adequately supported.



**STANDARD TECHNICAL SPECIFICATION
FOR
AIR WASHER**

SPECIFICATION NO.PES-554-01

VOLUME II B

SECTION D

REV. 00

DATE: NOV 2012

SHEET 3 OF 3

3.5

SPRAY NOZZLES

3.5.1

Spray nozzles shall be made of HDP (High density polyethylene) and shall be self cleaning type. The nozzles shall be designed to produce fine atomised spray and shall be spaced to give, uniform coverage of the air washer section. The pressure drop through the nozzle shall be in the range of 1.4 kg/cm² g to 2.4 Kg/cm²g

3.6

ELIMINATOR PLATE

3.6.1

Eliminator plate shall be fabricated from 22 gauge thick GSS (Zinc coating thickness as per approved TDS).The eliminator section shall have minimum 6 bends. Spacer bars, tie rods and supports shall be of galvanised steel construction. Eliminator box shall be complete with suitable drop tray and drain pipe.

3.7

SUCTION SCREENS

3.7.1

Suitable no. of suction screens shall be provided by vendor and one set of spare screens shall be furnished along with each air washer.

3.8

INSPECTION DOOR AND MARINE LIGHT

3.8.1

Air tight inspection door of 600x700mm, metallic construction shall be provided. The air washer shall be equipped with marine light as required.

3.9

MAKE UP, DRAIN AND QUICK FILL CONNECTION

3.9.1

The air washer shall be provided with quick fill and make up connection. The quick fill valve shall be a globe valve. Float valve for making connection shall be backed up by a gate valve. Drain connections complete with isolating valves shall be provided for both suction and main tank. Over-flow pipe shall be provided for main tank and shall be connected to drain pipe, before the isolating valve or drain. In case of masonry tanks suitable pipe pieces with stiffener plates shall be provided by Vendor for use during casting of masonry tank.

4.

DATA TO BE FURNISHED BY VENDOR AFTER AWARD OF CONTRACT

4.1.1

Performance curve for air washer

4.1.2

GA drg.

4.1.3

Foundation drag. weight, dynamic loading etc.

4.1.4

O&M manual



**AIR WASHER
DATA SHEET - A**

VOLUME II-B

SECTION D

REV 00

DATE NOV 2012

SHEET 1 OF 2

S.No.	DESCRIPTION	DETAILS
GENERAL		
1.	Designation	Air washers for power house building.
2.	Nos. required	Refer Section-C of Specific Technical Requirement
3.	Service	Evaporative Cooling of TG Hall & electrical bay
4.	Location	As per section-C/ Tender Layout Drg.
DESIGN DATA		
5.	Type	Sheet metal type, as per schedule of Ventilation system.
6.	Capacity M3/hr	Refer Section-C of Specific Technical Requirement
7.	Inlet air temperature	(Refer design data.)
8.	Saturation Efficiency (min).	To achieve saturation efficiency of 90%
9.	Allowable Pressure drop through Spray nozzle	2.4 Kg/cm ² (g) max.
9.	Pressure drop across Spray chamber	15 to 20 mm WG.
MATERIALS		
11.	Moisture Eliminators plates	24 SWG Galvanized Sheet (Vertical and brake type)./ 100% Virgin PVC of minimum finished thickness of 2 mm.
12.	Moisture Eliminators Frame	22 SWG G.I. Sheets.
13.	Distribution plates	18 G GSS to have 50% free area.
14.	Tank	MS
15.	Casing	Black M.S. (10 SWG min.)
16.	Louvers	20 G GSS sheet & frame of 18 G galvanized steel angle. Louvers with Bird screen of galvanized wire mesh of 10 mm square.
17.	Piping	MS Heavy Class Galvanized to IS: 1239 Part I, OR IS –3589 depending upon size.



**AIR WASHER
DATA SHEET - A**

VOLUME II-B

SECTION D

REV 00

DATE NOV 2012

SHEET 2 OF 2

- | | | |
|-----|----------------------|--|
| 18. | Suction Screen Water | Brass (40 mesh size 2 nos for each air washer) |
| 19. | Spray nozzles | Brass/Bronze with chrome plating or suitable plastic material (Nylon/Polymer) and shall be self cleaning type. |
| 20. | Flooding Nozzles | Nylon/Polymer. |
| 21. | Banks | Two spray banks each connected to individual header |

EQUIPMENT SELECTION CRITERIA

- | | | |
|-----|--|------------------------------------|
| 22. | Face Velocity through louver. | Not to exceed 2.5 m/s |
| 23. | Max. Pressure drop | Not to exceed 6.5 mm Wg when clean |
| 24. | Saturation efficiency | Not less than 90%. |
| 25. | Face velocity of air through spray chamber. | Not to exceed 2.5 m/s. |
| 26. | Allowable pressure drop for washing chamber. | 15 to 20 mm Wg. |

NOTE:

- 1) All parts coming in contact with moisture for air washer shall be spray galvanized/epoxy painted
(2 coat of rust preventing epoxy primer & 2 coat of finished paint from both sides.)
- 2) Moisture eliminator shall have bends at 30 Degree with the direction of air flow & shall have effectively hooked edges for trapping the water.



**STANDARD TECHNICAL SPECIFICATION
FOR
VENTILATION FANS**

SPECIFICATION NO.PES-554-03

VOLUME II B

SECTION D

REV. 02

DATE: NOV 2012

SHEET 1 OF 4

**STANDARD TECHNICAL SPECIFICATION
FOR
VENTILATION FANS**



**STANDARD TECHNICAL SPECIFICATION
FOR
VENTILATION FANS**

SPECIFICATION NO.PES-554-03

VOLUME II B

SECTION D

REV. 02

DATE: NOV 2012

SHEET 2 OF 4

1. GENERAL

This specification covers the design, manufacture, testing of performance at manufacturer's/sub-contractors works, delivery at site, handling at site, erection and commissioning of ventilation fans.

2. CODE AND STANDARDS

The design, manufacture and performance of equipment shall comply with all currently applicable statutes, regulations and safety codes in the locality where it is to be installed. The equipment shall conform to latest edition of applicable Indian Standards or their equivalent standards. Nothing in this specification shall be construed to relieve the vendor of this responsibility. In particular the equipment shall conform to the latest editions of the Following standards.

- 2.1.1 IS:4894 -Centrifugal fans
- 2.1.2 IS:3588 -Electric Axial Flow fans
- 2.1.3 IS:2312 -Propeller type A.C. ventilation fans
- 2.1.4 IS-3963 -Roof extractor units
- 2.1.5 BS:848 -Method of performance test for fans.
- 2.1.6 AMCA publication 99 standards handbook
- 2.1.7 AMCA standard 210, Test code for air moving devices.

3. DESIGN AND CONSTRUCTION

3.1 THE ENCLOSED DATA SHEET A GIVES THE NECESSARY DETAILS FOR CENTRIFUGAL/AXIAL/ROOF EXTRACTOR UNITS ETC.

3.2 WELDING PROCESS AND WELDERS EMPLOYED FOR FABRICATION SHALL BE QUALIFIED AS PER ASME SEC. IX

3.3 CASING

3.3.1 The centrifugal fans casing shall be of welded construction fabricated with heavy gauge material (min 3 mm) with flanges (min. 5 mm) on inlet and out let side for direct connection and shall be rigidly reinforced and supported by structural angles. The seams shall be permanently sealed airtight. Horizontal Split casings shall be provided on large size fans. Casing drain (at bottom) with threaded plug/ with valve shall be provided, as required. All mounting/ connecting holes shall be drilled off centre.

3.3.2 The axial flow casing for supply fans/roof extractors shall be of heavy gauge construction (min 3 mm) properly reinforced for rigidity and shall be complete with suitable supports. Access doors with suitable locking arrangement shall be provided in the casing for easy access to the motor and impeller. External junction box/ Terminal box on casing with IP-55 protection shall be provided, if required. Wiring for motor from external junction box/ Terminal box shall be through flexible conduit.

3.3.3 Suitable motor brackets designed for rigid mounting of motors, shall be provided for roof extractors and wall mounted exhaust/ supply fans.



**STANDARD TECHNICAL SPECIFICATION
FOR
VENTILATION FANS**

SPECIFICATION NO.PES-554-03

VOLUME II B

SECTION D

REV. 02

DATE: NOV 2012

SHEET 3 OF 4

3.4 IMPELLER

3.4.1 Centrifugal fan impeller shall have die formed, aerofoil or laminar blades welded to the rim and back plate and shall have non-overloading, self cleaning characteristics. Rim shall be spun to have smooth contour. If required, intermediate stiffening rings shall be provided. Shaft sleeves shall be furnished, if specified. The impeller, pulley and shaft sleeve shall be secured to the shaft by key and/or nuts (threaded opposite to direction of rotation of impeller). The impeller shall be statically and dynamically balanced.

3.4.2 The axial fan impeller shall be of high efficiency aerofoil design. The blades shall be mounted on a streamlined hub and the impeller shall be mounted directly on the motor shaft. Impeller shall be in one piece however; fabricated blades will be acceptable up to 450 mm impeller diameter.

3.4.3 Roof ventilator impeller may either be centrifugal or axial type. Backward inclined blades shall be provided for centrifugal impellers. Blades may be die-formed or cast. Axial flow impeller shall be directly mounted to motor shaft whereas centrifugal impeller may either be direct-driven or belt-driven. The shaft of belt-driven centrifugal fan shall be solid cold rolled carbon steel, ground and polished. However, direct mounted impellers are preferred.

3.5 BEARINGS:

3.5.1 The centrifugal fan bearing may be ball, roller or sleeve bearings of self-aligning heavy duty type with adequate capacity and life. Make of Bearings to be specified. Bearings shall be oil/grease lubricated and provided with fittings for lubrication from outside and shall be located in easily accessible position to facilitate maintenance.

3.6 INLET CONES AND GUARDS

3.6.1 Centrifugal fans inlet shall be spun to have a smooth contour. Inlet screen, if provided, shall be galvanised wire mesh of 25 mm square with wire thickness of min. 1.5 mm.

3.6.2 Inlet cone, outlet bell and suitably designed guards shall be provided.

3.7 GUIDE VANES:

3.7.1 In case of vane axial fans guide vanes shall be provided on discharge side.

3.8 BASE PLATE AND VIBRATION ISOLATORS

3.8.1 Base plate and vibration isolators, which may be double deflection rubber in shear or rubber in compression type or spring type shall be provided. With each fan rubber bushes, washers wherever needed for vibration isolator in sufficient nos. shall be included, as required, to ensure isolation of foundation from vibration of equipment. For roof ventilators suitable mounting arrangement shall be provided such that there is no ingress of rain water into the building.

3.9 HOOD AND COWL

3.9.1 Roof exhaustors shall be provided with hinge type hood providing easy access to motor and impeller. Weather proof lockable type disconnect switch shall be provided such that hood can open only when the disconnect switch is in 'off'



**STANDARD TECHNICAL SPECIFICATION
FOR
VENTILATION FANS**

SPECIFICATION NO.PES-554-03

VOLUME II B

SECTION D

REV. 02

DATE: NOV 2012

SHEET 4 OF 4

position. On larger size of roof ventilators hoods may be of split construction. 15 mm mesh galvanised bird screen shall be provided.

- 3.9.2 Rain protection cowls shall be designed to suit wall exhausters/supply fans for protecting fans from rain. The cowls shall be provided with bird screen of heavy gauge expanded metal netting.

3.10 SPEED

- 3.10.1 The speed of axial flow fans/roof ventilators shall not exceed 960 RPM for impeller dia exceeding 450 mm and shall not be greater than 1440 with impeller dia less than 450 mm.

4. MOTORS

Drive motors shall be of totally enclosed type, suitable for horizontal/vertical mounting as applicable and shall comply with the requirements of the specifications furnished elsewhere for motors.

5. ACCESSORIES

Accessories as specified in Data sheet-A and as required for satisfactory trouble free & safe operation of fans shall be provided.

TESTING AND INSPECTION

List of TCs arranged as per Approved Quality Plan shall be furnished along with copy of TCs at the time of inspection by BHEL

- Visual inspection of sheets/plates, angles, channels etc. – Pitting, lamination in sheets/ plates, angles and channels shall be avoided.- visual inspection by main contractor of BHEL.
- Sheets/ Plates - Test certificate shall be furnished for physical and chemical properties for sheets / plates- for review by BHEL
- Shaft: Mechanical and chemical— review by BHEL
- Motors (of approved make): Routine TC ,FLP TC if applicable
- Workmanship and dimensional check as per manufacturing drg. and approved Drgs.- by main contractor of BHEL.- Shall be checked by BHEL/ Customer during final inspection.
- Balancing of impellers- Dynamic balancing certificates shall be furnished –grade G.3 or better to ISO-1940. Balancing weights shall be positively locked/ welded to avoid loosening. - witness by manufacturer - TC to be furnished for review by BHEL(consisting of weight of impeller, radius of correction and balancing rpm). For spare impellers Dynamic Balancing shall be witnessed by BHEL.
- Performance test of one Centrifugal fan or Axial Fan /per type/per size as per applicable standard – by BHEL.

Centrifugal/ Axial fans 100% run tested by main contractor of BHEL. Run test by BHEL/Customer may be at random or 100%- Vibration shall be within satisfactory zone of VDI 2056 (group- G) machines when measured on bearing housing and noise level <85 dbA at 1 metre distance. Max. Temp. on bearing housing- 40 degrees Centigrade + ambient



CENTRIFUGAL FAN
DATA SHEET - A

VOLUME II-B

SECTION D

REV 00

DATE NOV 2012

SHEET 1 OF 3

<u>No.</u>	<u>Particulars</u>	<u>Data</u>
1	<u>General Information</u>	
1.1	Fan Designation/application. system/	Refer schedule of Ventilation Air washers & UAF Units.
1.2	Nos. required/capacity Technical	Refer Section-C of Specific Requirement
1.3	Location	Refer layout drg. Attached.
2.0	<u>Design Data</u>	
2.1	Type	DIDW for Air Washer and SISW for UAF
2.2	Type of blades	backward curved
2.3	Arrangement	To suit application as per layout.
2.4	Discharge direction	To suit application as per layout.
2.5	Duty	Continuous
2.6	Capacity at site (Cubic Meter/hr) & static pressure. Technical	Refer Section-C of Specific Requirement
2.7	Suction pressure (mm Wg)	As per system requirement.
2.8	Fluid	Atmospheric Air.
2.9	Suction Temperature	Refer weather data attached.
2.10	Suction humidity	Refer weather data attached.
3.0	<u>Materials</u>	
3.1	Fan Scroll	Heavy Gauge Mild Steet to IS: 2062 with galvanised
3.2	Fan Casing (side plates & stiffeners)	Heavy Gauge Mild Steet to IS: 2062 / IS: 1079 / Eq. Minimum 3 mm thick casing.
3.3	Impeller	Mild Steel/plate to IS: 2062
3.4	Impeller hub	Mild Steet/plate to IS: 2062
3.5	Impeller back plate blade & shroud	Mild Steet to IS: 2062 / IS: 1079 / Eq.



CENTRIFUGAL FAN
DATA SHEET - A

VOLUME II-B

SECTION D

REV 00

DATE NOV 2012

SHEET 2 OF 3

3.6	a) Shaft b) Shaft sleeve	EN-8 or eqv. -do-
3.7	Support frame and structure.	Mild Steel to IS: 2062
3.8	Flexible connection at outlet impregnated canvas with MS Flanges and cleats (3mm thick).	Fire resistant type plastic
3.9	V Belt	ISI marked (Reinforced rubber section to IS: 4776)
3.10	V Pulley per	Cast Iron multi groove to grade FG 20 as
3.11	Slide rails	IS: 210. Having taper lock type M.S./C.I.
3.12	Connection pieces	G.I. according to supplier's design
3.13	Bolts & nuts	M.S. Galvanized / Epoxy painted.
3.14	Vibration isolating pads, washers and spring if any.	Hard synthetic rubber
4.0	<u>ACCESSORIES</u>	
4.1	Common base plate	Required.
4.2	Anchor bolts	-do-
4.3	Vibration Isolators	Hard synthetic rubber
4.4	V-belt pulleys	-do-
4.5	V-belts	Reinforced rubber of appropriate section
4.6	Belt guard	Required.
4.7	Outlet damper	Required(M.S. Heavy Gauge)
4.8	Inlet guard	Required.
4.9	Inlet Vane (variable)	Not required.
4.10	Drain valve	Required.
4.11	Acoustic silencers	Not required.
5.0	<u>Motor</u>	
5.1	Motor by	Bidder



CENTRIFUGAL FAN
DATA SHEET - A

VOLUME II-B

SECTION D

REV 00

DATE NOV 2012

SHEET 3 OF 3

5.2 Starter by

BHEL

6.0 Painting of fans including base frame

Galvanized / epoxy painting (as per
Section-C & painting specifications)

NOTE:

- 1) Motors shall have 15 % margin on duty power point.
- 2) Fan shall be designed to operate with in 9% and 25% of system throttling line.
- 3) Opposed Multiple louvers damper shall be provided at fan outlet. Louvres shall be of 2 mm thick MS (galvanized). Casing shall be of 3.15 mm thick MS (galvanized).

**VENTILATION FAN (R.E.UNIT)****DATA SHEET - A**

VOLUME II-B

SECTION D

REV 00

DATE : NOV 2012

SHEET 1 OF 2

General Information

- | | |
|------------------|---|
| 1) Designation | Roof extractor Units for areas as per schedule of ventilation system. |
| 2) Nos. required | As per schedule. |
| 3) Service | Continuous |
| 4) Location | Roof of respective areas. |
| 5) Area | As per schedule |

Design Data

- | | |
|----------------------------------|--|
| 6) Type | axial flow type. |
| 7) Air delivery capacity system. | as per schedule of ventilation |
| 8) Fluid | Atmospheric Air. |
| 9) Temperature | 50 Deg. C |
| 10) Static Pressure required | As per Section 'C' schedule of ventilation system. |
| 11) Outlet air velocity | Not more than 12 m/sec. |

Materials

- | | |
|--|---|
| 12) Casing/cowl/hood | M.S. Sheet to IS: 2062 /IS: 1079/Eq. |
| 13) Impeller
617 | Cast Aluminium alloy to A-6M IS-
Grade LM6 |
| 14) Support frame and structure.
2062). | M.S. of adequate thickness (IS- |

ACCESSORIES

- | | |
|------------------------------|------|
| 15) Vibration isolating pads | Yes. |
| 16) Base frame for mounting | Yes. |
| 17) Wire Guard at inlet. | Yes. |
| 18) Disconnect switch | Yes. |

**VENTILATION FAN (R.E.UNIT)****DATA SHEET - A**

VOLUME II-B

SECTION D

REV 00

DATE : NOV 2012

SHEET 2 OF 2

19) Gravity damper at outlet

Yes

Motor

20) Motor by

Bidder

21) Starter by

Bidder

22) Type of motor

Conforming to IS: 325 latest/as per specification.

23) Free delivery test

Yes.

24) Performance test at specified duty point.

Yes

25) Speed

Not more than 1500 RPM

NOTE:

1. Motors shall have 15% on duty power Point.



VENTILATION FAN (R.E.UNIT)

DATA SHEET - A

VOLUME II-B

SECTION D

REV 00

DATE : NOV 2012

SHEET 3 OF 2



Ventilation Fan (Axial Flow Type)

DATA SHEET - A

VOLUME II-B

SECTION D

REV 00

DATE NOVEMBER 2014

SHEET 1 OF 2

No. Particulars

Data

General Information

- | | |
|---------------------|--|
| 1) Designation | Supply/Exhaust Fans. |
| 2) Nos. required in | Refer schedule of Ventilation system section-C under specific technical requirement. |
| 3) Service air. | To exhaust warm air/to supply fresh |
| 4) Location | Wall mounted. |
| 5) Area | Same as above in 2. |

Design Data

- | | |
|----------------------------------|--|
| 6) Type supply | Axial fans suitable for 415V/3 phase for Motor. |
| 7) Air delivery capacity system. | As per schedule of ventilation |
| 8) Fluid | Atmospheric Air. |
| 9) Temperature | Refer Section of specific technical requirement |
| 10) Static Pressure required | As per Section 'C' schedule of ventilation system. |
| 11) Outlet Air Velocity | Not more than 12 m/sec. |

Materials

- | | |
|---|---|
| 12) Casing | M.S. (IS-2062) |
| 13) Impeller (617) | Cast Aluminium. (Alloy A-6M, IS- |
| 14) Hub | Al Alloy. |
| 15) Support frame and structure. (Galvanized/ | M.S. of adequate thickness
Painted) IS-2062. |
| 16) Neoprene rubber pads | As required. |



Ventilation Fan (Axial Flow Type)

DATA SHEET - A

VOLUME II-B

SECTION D

REV 00

DATE NOVEMBER 2014

SHEET 2 OF 2

- | | |
|---|--|
| 17) Coned inlet for wall exhausters/supply fans | MS (IS-2062) |
| 18) Supporting frame for mounting. | Required. |
| 19) Protective screen at inlet. | Yes (Min 14 SWG Galvanized wire knitted in 1" square mesh. |
| 20) Rain Protection Cowl | Aluminum or hot dip Galvanized after fabrication from M.S. |

Motor

- | | |
|----------------|--------|
| 21) Motor by | Bidder |
| 22) Starter by | BHEL |

NOTE:

- 1) For Battery Room, motor for fan shall be of flame proof type & fan of spark proof construction with Epoxy painting.
- 2) Gravity type damper shall be provided at the outlet of axial fan for exhaust application.
- 3) Motor shall have 15% margin over Duty Point.



Ventilation Fan (Axial Flow Type)

DATA SHEET - A

VOLUME II-B

SECTION D

REV 00

DATE NOVEMBER 2014

SHEET 3 OF 2



**STANDARD TECHNICAL SPECIFICATION FOR
CENTRIFUGAL PUMPS**

SPECIFICATION NO. PES-554-05

VOLUME II-B

SECTION D

REV 01

DATE NOV 2012

SHEET 1 OF 8

**STANDARD TECHNICAL SPECIFICATION
FOR
CENTRIFUGAL PUMPS**



STANDARD TECHNICAL SPECIFICATION FOR CENTRIFUGAL PUMPS

SPECIFICATION NO. PES-554-05

VOLUME II-B

SECTION D

REV 01

DATE NOV 2012

SHEET 2 OF 8

1.0 GENERAL

This specification covers the design, material, constructional features, manufacture, assembly, inspection and testing at manufacturer's or his subcontractor's works, suitable painting requirements of centrifugal pumps and drives complete with all accessories as specified hereinafter.

2.0 CODES AND STANDARDS

2.1 The design, manufacture, inspection, testing & performance of the pumps as specified hereinafter, shall comply with the requirements of the latest revision of the following standards as indicated below (as applicable):

- a) IS-1520 :Horizontal centrifugal pumps for clear, cold and fresh water
- b) IS-5120 :Technical requirements - Rotodynamic special purpose pump
- c) IS-1710 :Vertical turbine pumps for clear, cold and fresh water
- d) Hydraulic Institute Standards of USA
- e) BS - 599 :Method of testing Pumps
- f) PTC - '6' :Centrifugal Pumps Power test code
- g) API - 610

Wherever standards for certain aspects materials etc., not mentioned, the same shall be as per the applicable Indian or International standards.

2.2 In case of any conflict between the above codes/standards and this specification, the later shall prevail and in case of any further conflict in this matter, the decision of Purchaser's engineer shall be final and binding.

3.0 DESIGN REQUIREMENTS

3.1 The pumps shall be of heavy duty suitable for long periods of uninterrupted service and shall be standard product of the manufacturer thoroughly proven for satisfactory performance and reliability

3.2 The materials of construction of various components shall be as indicated under Data Sheet-A and where not specified to the applicable Indian/British/American standards.

3.3 All pressure containing components including the pump casing, nozzles and stuffing box housing shall be designed, fabricated and tested in accordance with applicable Indian standards if not specified otherwise.

3.4 The pump shall be suitable for handling the fluid as specified in Data Sheet-A

4.0 CONSTRUCTIONAL FEATURES

4.1 Pump Casing

4.1.1 Pump casing may be axially or radially split or barrel type construction as specified in the pump data specification sheet. The casing shall be designed to withstand the maximum pressure developed by the pump at the pumping temperature.



**STANDARD TECHNICAL SPECIFICATION FOR
CENTRIFUGAL PUMPS**

SPECIFICATION NO. PES-554-05

VOLUME II-B

SECTION D

REV 01

DATE NOV 2012

SHEET 3 OF 8

4.1.2 Pump casing shall be provided with adequate number of vent and priming connections with valves, unless the pump is made self venting & priming. Casing drain, as required, shall be provided complete with drain valves.

4.1.3 Pump shall preferably be of such construction that it is possible to service the internals of the pump without disturbing suction and discharge piping connections.

4.1.4 Under certain conditions, the pump casing nozzles will be subjected to reactions from external piping. Pump design must ensure that the nozzles are capable of withstanding external reactions not less than those specified in API-610.

4.2 **Impeller**

Unless specifically indicated under Data Sheet-A enclosed, the pump impellers shall be of closed vane type. The impellers shall be secured to the shaft and shall be retained against circumferential movement by keying, pinning or lock rings. Impellers shall be statically and dynamically balanced individually. The assembled rotor shall be dynamically balanced and checked for eccentricity.

4.3 **Wearing Ring**

Renewable wearing rings for the casing and/or the impellers and renewable shaft sleeves, shall be provided for all pumps. Length of the shaft sleeves must extend beyond the outer faces of gland packing or seal and plate so as to distinguish between the leakage between shaft & shaft sleeve and that past the seals/gland.

4.4 **Shaft**

Shaft size selected shall take into consideration the critical speed which shall be away from the operating speed as recommended in applicable Code/Standard. The critical speed shall also be at least 10% away from runaway speed.

4.5 **Bearings**

Bearings and hydraulic devices (if provided for balancing axial thrust) of adequate design shall be furnished for taking the entire pump load arising from all probable conditions of continuous operation throughout its Range of Operation and also at the shut off condition. The bearing shall be designed on the basis of 20,000 working hrs minimum for the load corresponding to the duty point. Proper lubricating arrangement for the bearings shall be provided. The design shall be such that the bearing-lubricating element does not contaminate the liquid being pumped. Where there is a possibility of liquid entering the bearing, suitable arrangement in the form of deflectors or otherwise shall be provided ahead of bearing assembly. Bearings shall be easily accessible without disturbing the pump assembly.

4.6 **Stuffing Boxes**

Packed type stuffing boxes of adequate depth with lantern rings shall be provided to minimize the leakage. In all cases where the pump suction is below atmospheric pressure, the shaft packing shall be sealed by the liquid pumped by tapping off from the pump discharge itself and all pipes, valves, fittings etc., required for this shall be furnished by the manufacturer.

4.7 **Shaft Couplings**



**STANDARD TECHNICAL SPECIFICATION FOR
CENTRIFUGAL PUMPS**

SPECIFICATION NO. PES-554-05

VOLUME II-B

SECTION D

REV 01

DATE NOV 2012

SHEET 4 OF 8

The pumps shall be directly coupled to their drives through heavy duty flexible coupling. Suitable coupling guards shall be provided along with the coupling. The pump and its drive motor shall be mounted on a common base plate.

4.8 Base Plate and sole Plate

Unless otherwise stated the data specification sheet, a common base plate mounting both for the pump and drive shall be furnished. The base plate shall be of rigid construction, suitably ribbed and reinforced. Base plate and pump supports shall be so constructed and the pumping unit so mounted as to minimize misalignment caused by mechanical forces such as normal piping strain, hydraulic piping thrust, etc. Suitable drain taps and drip lip shall be provided.

If required in the data specification sheet, steel sole plates shall be provided, below the base plate.

4.9 Prime Mover

The drive motor selected shall conform to the requirements of the enclosed motor specifications.

4.10 Lifting arrangement

Each pump and motor shall incorporate suitable lifting attachments e.g. lifting lugs or eye bolts etc., to facilitate erection and maintenance.

5.0 Performance Requirements

5.1 The pump shall be designed to have best efficiency at the specified duty point. The pump set shall be suitable for continuous operation at any point within the Range of Operation as stipulated in the data specification sheets.

5.2 Pump shall have a continuously rising head capacity characteristics from the specified duty point towards shut off point, the maximum being at shut off. Power capacity characteristic will be non-overloading type i.e. 110% of the design flow the power required to drive the pump will be practically the same as that at the design flow.

5.3 Wherever specified in data sheet, pumps of each category shall be suitable for parallel operation. The head vs capacity, input power vs. capacity characteristics, etc., shall match to ensure equal load sharing and trouble free operation throughout the range.

5.4 The pump motor set shall be designed in such a way that there is no damage due to the reverse flow through the pump which may occur due to any malfunction of the system.

6.0 Drive Rating

6.1 The power rating of the drive shall be selected such that a minimum margin of 15% is available over the pump input power required at the rated duty point. However, the drive rating shall not be less than the maximum power requirement at any point within the 'Range of Operation' specified.



**STANDARD TECHNICAL SPECIFICATION FOR
CENTRIFUGAL PUMPS**

SPECIFICATION NO. PES-554-05

VOLUME II-B

SECTION D

REV 01

DATE NOV 2012

SHEET 5 OF 8

6.2 In cases where parallel operation of the pumps are specified the actual drive rating is to be selected by the bidder considering overloading of the pumps in the event of tripping of one of the operating pumps.

6.3 The bidder under this specification shall assume full responsibility in the operation of the pump and the drive as one unit.

7.0 SCOPE OF INSPECTION AND TESTING

7.1 Castings

7.1.1 Witnessing pouring and thereafter physical testing of castings of 'Critical' nature such as casings, impellers, diffusers.

7.1.2 Identification and correlation with test reports for all tests as per the relevant material specifications for castings of 'Major' nature such as suction bell, discharge elbow, stuffing box, gland, wearing rings, shaft sleeves etc.

7.1.3 Foundry's conformity certificate for castings of 'Minor' nature such as base plates, covers etc.

7.1.4 Verification of neat treatment charts (as applicable)

Note: Casting effects shall not be filled by any method until an unless approved by BHEL/their customer

7.2 Forgings and

7.2.1 Identification and correlation with mill test certificates for all tests as per the relevant specifications for important forgings like casings, stage bodies, diffusers, shaft material.

7.2.2 Verification of neat treatment charts (time temperature) (as applicable).

7.3 Fabricated items

7.3.1 Identification and correlation with mill test certificates for material of items such as discharge bellows, column pipes etc.

7.3.2 Approval of welding procedure specifications and qualifications of weld procedures and personnel.

7.3.3 Dye penetrant tests of weldment as per ASTM E-165 and acceptance norm as per ASME Sec.VIII, Div.1, Appendix 8

7.3.4 Verification of heat treatment charts (time temperature), (as applicable)

7.3.5 Hydro test as per para 7.5.1 below.

Note: For para 7.1.2, 7.2.1 and 7.3.1 above; in case correlating test certificates are not available, material shall be identified by BHEL and physical tests conducted by the supplier in the presence of BHEL



**STANDARD TECHNICAL SPECIFICATION FOR
CENTRIFUGAL PUMPS**

SPECIFICATION NO. PES-554-05

VOLUME II-B

SECTION D

REV 01

DATE NOV 2012

SHEET 6 OF 8

7.4 In process Inspection and Testing

7.4.1 Dye penetrant testing after machining for impellers including vanes, pump shaft, diffusers as per applicable code; in absence of which, as per ASTM E - 165. No defect shall be permitted on moving parts. On static parts acceptance norms are as per ASME Sec.III NB 2546.

7.4.2 Ultrasonic testing of dynamic duty component, i.e. pump shafts (50mm dia and above) and static duty forgings i.e. Barrel, casting (15mm and above wall thickness) as per applicable code, in absence of which as per ASTM E388 and acceptance norms as stipulated hereunder.

7.4.3 Acceptance norms for UT for dynamic duty components. the following defects are unacceptable :

- a) Cracks, flakes, seams and laps
- b) Defects giving indications longer than that from a 4mm equivalent flaw.
- c) Group of defects with maximum indications less than that from a 4mm equivalent flaw, which cannot be separated at testing sensitivity, if the back echo is reduced to less than 50%.
- d) Defects giving indications of 2 to 4mm dia. equivalent flaw separated by distance less than four times the size of the larger of the adjacent flaw.

7.4.4 For static duty components - as per NB 2542.2 of ASME Sec. III.

7.4.5 Hydro tests of all pressure parts such as casings, column pipes, discharge elbows etc., at two times duty point pressure or 1.5 time shut off pressure, whichever is higher for 30 min., without any leakage.

Note : In case the pump is required to boost certain pressure, the inlet pressure head shall also be taken into consideration to compute test pressures.

7.4.6 Static and dynamic balancing of individual impellers and also assembled rotors as per V.D.I. 2060 Q 6.3 or ISO 1940 G 6.3.

7.5 Performance Test

7.5.1 Pump testing with unit supply motor as per specifications and acceptance norms cited elsewhere, in absence of which as per IS 5120 latest edition. Performance shall be checked for minimum of 7 points (including shut off head and over load) following characteristics shall be checked:

Capacity V/s Head

Capacity V/s Power absorbed by pump

Capacity V/s pump efficiency

Note : For pump of fire protection system, performance test shall be conducted up to 150% of rated capacity

7.5.2 NPSH test in case specifically mentioned elsewhere



**STANDARD TECHNICAL SPECIFICATION FOR
CENTRIFUGAL PUMPS**

SPECIFICATION NO. PES-554-05

VOLUME II-B

SECTION D

REV 01

DATE NOV 2012

SHEET 7 OF 8

7.5.3 Vibration and noise level measurement. Acceptance norms shall be as per manufacturers standards.

7.5.4 Overall dimensions as per GA drawings

7.5.5 Examination after selective opening up after running for pumps operating at speed over 1800 rpm and capacity exceeding 68M³/hr.

7.5.6 Painting and packing as per technical specification.

7.6 Test at site

The pumps will be tested at site by the purchaser to verify their performance. If the pumps fail to operate smoothly or within the required performance all such deficiencies shall be rectified by the manufacturer by making suitable alternatives in the pump set and additional tests required to show the effect of such alterations shall be performed by him.

7.7 Performance Guarantee

The vendor shall guarantee the material and workmanship of all components as well as the operation of the pump as per requirement of this specification.

The vendor shall also guarantee for each pump the total dynamic head at the specified rated capacity and also corresponding efficiency, brake horse power and shut off head.

8.0 CLEANING, PROTECTION & PAINTING

Before shipment of the equipment to be supplied under this specification the necessary cleaning, flushing etc., as per manufacturers standard shall be done to remove all dirt, scales etc. Shop coats of rust inhibiting paints, lacquers etc., shall be applied to various parts as necessary. Flanges, inlet and outlet pipe, etc shall be protected.

9.0 DRAWINGS, TECHNICAL DOCUMENTS AND OTHER INFORMATION REQUIRED WITH THE PROPOSAL

9.1 Fully dimensioned outline GA drawings of the pump motor assembly unit for each type and size offered. This drawing should include:-

- i) Foundation base plate and sole plate details as applicable
- ii) Civil foundation and anchor bolts details and loading data
- iii) Minimum submergence required for the pump (if applicable)

9.2 Cross sectional drawing of the equipment showing the details of assembly of components and their material of construction with standard applicable codes.

9.3 Performance characteristics (Discharge capacity vs head, BHP and efficiency of the pumps.



**STANDARD TECHNICAL SPECIFICATION FOR
CENTRIFUGAL PUMPS**

SPECIFICATION NO. PES-554-05

VOLUME II-B

SECTION D

REV 01

DATE NOV 2012

SHEET 8 OF 8

- 9.4 Motor speed torque curve superimposed on pump speed torque curve. Required NPSH of pump.
- 9.5 Experience list about the supply and successful operation of similar pumps for similar application.
- 9.6 A comprehensive write up or brochure on the details of manufacturing and testing facilities in the shop of the manufacturer.
- 9.7 Quality plan for the equipment being offered, in BHEL format as practiced in the manufacturer's works and Field Quality Plan for receipt, storage erection, commissioning & testing at site.
- 9.8 Data sheet-B with all the particulars filled in.

10.0 DRAWINGS AND DATA AFTER AWARD OF CONTRACT

The vendor shall furnish the drawings and other technical documents as required in Data Sheet-C enclosed with this specification

10.1 MANUFACTURERS NAME AND TAG. PLATES

Each pump shall have a permanently attached brass/metal tag on the body indicating the following information both in Hindi and English.

- a) Manufacturer's name and trade mark
- b) Design Capacity and Head
- c) Design
- d) Purchaser's tag no. as furnished during the contract. The purchaser's tag no. will be indicated by the Purchaser on the drawing submitted for approval by the vendor.

11.0 DRAWINGS/DOCUMENTS TO BE FURNISHED BY VENDOR AFTER THE AWARD OF CONTRACT.

- 11.1 Certified GA drawings of pump motor assembly weights, crane
- 11.2 Detailed cross sectional drawings of the pump and motor assembly and all equipment & accessories supplied under the this specification along with details of material of construction with applicable standard codes
- 11.3 Foundation drawings with details of foundation pocket indicating static as well as dynamic load and other data with dimensions.
- 11.4 Certified characteristics curves (discharge capacity vs. head, BHP and efficiency) of each type of pump and motor.
- 11.5 Material and other test certificates as required by the application clauses of this specification.
- 11.6 Motor speed torque curves super imposed on pump speed torque curves.
- 11.7 Quality plan along with complete details of testing and inspection requirements of centrifugal pumps in BHEL format. Vendor shall also furnish Field Quality Plan.



**STANDARD TECHNICAL SPECIFICATION FOR
CENTRIFUGAL PUMPS**

SPECIFICATION NO. PES-554-05

VOLUME II-B

SECTION D

REV 01

DATE NOV 2012

SHEET 9 OF 8

11.8 Installation , operation and maintenance manual.

11.9 Other drawings and data, if necessary.



**CENTRIFUGAL PUMPS
DATA SHEET - A**

VOLUME II-B

SECTION D

REV 00

DATE NOV 2012

SHEET 1 OF 2

<u>S.No.</u>	<u>DESCRIPTION</u>	<u>DETAILS</u>
1)	Designation	Air washer Pumps.
2)	Type	Horizontal Centrifugal Type.
3)	Quantity	As per section-C
4)	Installation Washer	On floating type foundation inside Air Room
5)	Fluid to be handled	Filtered Water.
6)	Temperature of Fluid	To suit.
7)	Capacity Cum/Hr TDH at	To suit system requirements however head shall Not be less than 35 MWC.
8)	Duty	-----Continuous (24Hr./day)-----
9)	Suction condition	-----Flooded-----
10)	Type of drive	Direct (flexible coupling)
11)	Type of prime mover	LV Ac Motor.
12)	Maximum speed	Not more than 1500 RPM
13)	Type of lubrication	Grease Lubrication

MATERIALS OF CONSTRUCTION

<u>S.No.</u>	<u>DESCRIPTION</u>	<u>DETAILS</u>
a)	Impeller	Bronze
b)	Pump Shaft	Carbon Steel C-45, IS-1570 or class-IV, IS- 1875
c)	Casing	Cast Iron, grade-20, IS- 210
d)	Wearing ring	Bronze
e)	Shaft Sleeve	Bronze
f)	Base Plate/frame	Cast Iron to Grade FG-200 IS-210/fabricated Mild steel



**CENTRIFUGAL PUMPS
DATA SHEET - A**

VOLUME II-B

SECTION D

REV 00

DATE NOV 2012

SHEET 2 OF 2

- | | | |
|-----------|---------------------|--|
| g) | Counter Flanges | Mild Steel |
| h) | Stuffing box bush | Deep Bronze packing to be renewable with Case. |
| i)
not | Stuffing box gland | Flexible graphite or PTFE (Asbestos shall be used) |
| j) | Pump Motor Coupling | Pin & Bush type (Flexible) |
| k) | Bolt and Nuts | MS |

15) **ACCESSORIES REQUIRED**

The following accessories shall be provided by the bidder for each pump.

- | | | |
|----|--|-----|
| a) | Priming funnel | Yes |
| b) | Drain piping upto
Common drain point. | Yes |
| c) | Vent | Yes |
| d) | Suction & Discharge
Pressure gauges | Yes |
| e) | Companion flanges | Yes |
| f) | Common base plate | Yes |
| g) | Suction strainer. | Yes |
| h) | Isolating valve. | Yes |
| i) | NRV at pump outlet at inlet/outlet | Yes |
| j) | Any special requirements | Yes |
| k) | Inspection & Testing | Yes |



**1X800 MW TANGEDCO NORTH CHENNAI
TPP– (FGD SYSTEM)
HVAC SYSTEM
LIST OF MAKES**

**SPECIFICATION NO. PE-TS-485- (571-13000-
A)-A001 (REV-0)**

SECTION : I

SUB-SECTION : E

REV 00

SHEET 1 OF 15

**SECTION-I
SUB SECTION -E**

ANNEXURE-I

LIST OF MAKES OF SUB-VENDOR ITEMS



**1X800 MW TANGEDCO NORTH CHENNAI
TPP– (FGD SYSTEM)
HVAC SYSTEM
LIST OF MAKES**

SPECIFICATION NO. PE-TS-485- (571-13000-A)-A001 (REV-0)

SECTION : I

SUB-SECTION : E

REV 00

SHEET 2 OF 15

SLNo	ITEM	VENDOR
1	SCREW CHILLER	YORK
		TRANE
		CARRIER
		KIRLOSKAR
		DUNHAM BUSH
		MCQUAY (DAIKIN)
		BLUE STAR
		VOLTAS
2	PRECISION PACKAGE UNITS	STULZ
		UNIFLAIR
		EMERSON PROCESS MANAGEMENT (ROSEMOUNT)
		BLUEBOX
		CLIMADENTA
3	PACKAGE UNIT	VOLTAS
		BLUE STAR
		CARRIER
4	SPLIT AIR CONDITIONER	VOLTAS
		BLUE STAR
		CARRIER
		HITACHI-HIREL
		LG
5	AIR HANDLING UNITS	VOLTAS
		BLUE STAR
		ZECO
		CARRYAIRE (FLAKT)
		EDGETECH
		ETHOS
		SYSTEM AIR
		WAVES AIRCON
6	AHU FAN (CENTRIFUGAL FAN)	CB DOCTOR
		FLAKT
		KRUGER
		NICOTRA
		COMEFRI
		MARATHON
		PATEL AIR
		ADVANCE
		DRAFT AIR
		HYDERABAD POLLUTION
		SK SYSTEM



**1X800 MW TANGEDCO NORTH CHENNAI
TPP– (FGD SYSTEM)
HVAC SYSTEM
LIST OF MAKES**

**SPECIFICATION NO. PE-TS-485- (571-13000-
A)-A001 (REV-0)**

SECTION : I

SUB-SECTION : E

REV 00

SHEET 3 OF 15

		SARLA
7	LV MOTORS (NON FLAME PROOF)	SIEMENS
		ABB
		CGL
		MARATHON
		KEC
		BHARAT BIJLEE
		NGEF
		JYOTI
		LHP
		BHARAT ELECTRIC
8	AIR FILTER	PUROLATOR
		FMI
		ANFILCO
		TENACITY
		JOHN FOWLER
		SPECTRUM
		AIR TECH
		PUROMATIC
9	FRESH AIR/ SUPPLY/ EXHAUST/ RE UNIT FANS	FLAKT
		KHAITAN
		PATEL AIR
		NICOTRA
		SARLA (SITAL)
		KRUGER
		MARATHON
		C B DOCTOR
		HYDERABAD POLLUTION
		SK SYSTEM
ADVANCE		
10	INSULTATION MATERIAL	BEARDSHEL
		K-FLEX
		PARAMONT
		ARMAFLEX
		SUPREME
		LLOYDS
		UP TWIGA
		AEROCELL
11	BALANCING VALVE	ADVANCE
12	BUTTERFLY VALVES	ADVANCE
		AUDCO



**1X800 MW TANGEDCO NORTH CHENNAI
TPP– (FGD SYSTEM)
HVAC SYSTEM
LIST OF MAKES**

SPECIFICATION NO. PE-TS-485- (571-13000-A)-A001 (REV-0)

SECTION : I

SUB-SECTION : E

REV 00

SHEET 4 OF 15

		FOURESS ENGG
		INTER VALVE
		BDK
		WEIR BDK
		TYCO
		CRANE PROCESS
		KEystone
		FLUIDLINE
		INSTRUMENTATION LTD
		R AND D MULTIPLES (METAL CAST) PVT LTD
		SURYA VALVES AND INSTRUMENTS MFG CO
		PENTAIR VALVES AND CONTROLS INDIA PRIVATE LIMITED
		UPADHAYA VALVES MANUFACTURERS PRIVATE LIMITED
		VENUS PUMPS AND ENGG. WORKS
13	NON RETURN VALVE	LEADER VALVES
		H SARKAR
		FLUIDLINE
		HI-TECH
		CRESCENT VALVES
		A V VALVES
		BANKIM
		SHIVADURGA
		SURYA VALVES AND INSTRUMENT MANUFACTURING
		ATAM VALVES
		GM DAULI & SONS
		KBL
		VENUS PUMPS AND ENGINEERING WORKS
14	4 WAY MIXING VALVE WITH ACTUATING MOTOR	SIEMENS BUILDING TECHNOLOGY
		JOHNSON
		BELIMO
		HONEYWELL AUTOMATION
		RAPID CONTROL
		ALC
15	BUTTERFLY VALVE (MOTORIZED)	ANERGY
		ADVANCE
		BELIMO
		JOHNSON
		HONEYWELL AUTOMATION
		SIEMENS



**1X800 MW TANGEDCO NORTH CHENNAI
TPP– (FGD SYSTEM)
HVAC SYSTEM
LIST OF MAKES**

SPECIFICATION NO. PE-TS-485- (571-13000-A)-A001 (REV-0)

SECTION : I

SUB-SECTION : E

REV 00

SHEET 5 OF 15

		LEADER
		H.SARKAR
		FLUID LINE
		A V VALVES
		BANKIM & COMPANY
		SURYA VALVES AND INSTRUMENT MANUFACTURING
		ATAM VALVES
		GM DAULI & SONS
		KBL
		VENUS PUMPS AND ENGINEERING WORKS
16	ACTUATOR FOR MOTORIZED BUTTERFLY VALVE	SIEMENS BUILDING TECHNOLOGY
		JOHNSON
		BELIMO
		HONEYWELL
		RAPID CONTROL
		ALC
		AUMA
		LIMITORQUE
17	Y / POT STRAINER	MULTITEX
		GREAVES COTTON
		JAYPEE
		SANT VALVES
		OTOKLIN
		GRAND PRIX
		GUJARAT OTOLIFT
		DS ENGG
		SAROJINI ENTERPRISE
		BHATIA ENGINEERING
		FILTRATION ENGINEERS INDIA PVT LTD
		SUNGOV ENGINEERING
18	Pipes (MS/GI) - ERW	SURYA ROSHNI
19	Pipes (MS/GI) - ERW	TISCO
		DADU PIPES
		INDUS TUBES
		WELSPUN
		TATA
		BST
		JINDAL
		SAIL
		PSL
		LALIT PROFILE



**1X800 MW TANGEDCO NORTH CHENNAI
TPP– (FGD SYSTEM)
HVAC SYSTEM
LIST OF MAKES**

SPECIFICATION NO. PE-TS-485- (571-13000-A)-A001 (REV-0)

SECTION : I

SUB-SECTION : E

REV 00

SHEET 6 OF 15

		SAMSHI PIPE INDUSTRIES
		S MUKUT PIPES
		MANN INDUSTRIES
		SURENDRA ENGINEERING
		PRATIBHA PIPES AND STRUCTURES PVT LTD
		JCO GAS PIPES
		NUKAT TANK AND VESSELS
		GOODLUCK TUBES
		ADVANCE STEEL TUBES
		BIHAR TUBES
		HITECH PIPES
		RATNAMANI
		MAHARASHTRA SEAMLESS
20	PIPING - CS SEAMLESS (ASTM A 106)	ISMT
		MAHARASTRA SEAMLESS
21	GI SHEETS FOR DUCTING	TISCO
		INDIAN IRON & STEEL CO
		RASHTRIYA ISPAT NIGAM LIMITED
		ESSAR
		ISPAT INDUSTRIES
		JSW
		LLOYDS
		BHUSHAN STEELS
		TATA
		SAIL
		JINDAL
22	FIRE DAMPER	TSC
		CARRYAIRE
		RAVISTAR (SYSTEM AIR)
23	GRILL/DIFFUSER/VOLUME CONTROL DAMPER	AIR FLOW
		TSC
		AIR MASTER
		CARRYAIRE
		RAVISTAR (SYSTEM AIR)
24	STRIP HEATER	ESCORTS
		RACOLDS
		DASPASS
		ALCO
		HEATCO
		HOTSET
25	PAN HUMIDIFIER	RAPID COOL



**1X800 MW TANGEDCO NORTH CHENNAI
TPP– (FGD SYSTEM)
HVAC SYSTEM
LIST OF MAKES**

SPECIFICATION NO. PE-TS-485- (571-13000-A)-A001 (REV-0)

SECTION : I

SUB-SECTION : E

REV 00

SHEET 7 OF 15

		HOTSET
		ALCO
26	RELIEF / PURGE VALVE	BRASSOMATIC
27	THERMOSTATS	HONEYWELL AUTOMATION
		RANCO
		PENN
		DANFOSS
		INDFOSS
		JHONSON CONTROL
		RANUTROL
28	HUMID STAT	JHONSON CONTROL
		HONEYWELL AUTOMATION
		PENN
29	ANTI FREEZE THERMOSTAT	RANCO
		HONEYWELL AUTOMATION
		PENN
		DANFOSS
		INDFOSS
30	PRESSURE/ DP/ VACUUM/ TEMPERATURE SWITCH	BELLS CONTROLS LTD
		DANFOSS
		DK INSTRUMENTS
		DRESSER
		SOR INC
		VASU
		SWITZER INSTRUMENT LTD.
		INDFOSS
		TRAFAG
		GIC
		ASHCROFT INDIA PVT LTD.
		KASTURBA UDYOG
		BARKSDALE GMBH
		PRECISION MASS PRODUCTS
		MITTAL REFRIGERATION
31	TEMPERATURE SWITCH	INDFOSS
		SIEMENS
		DANFOSS
		DK INSTRUMENTS
		SOR INC
		VASU
		DRESSER
		TOSHNIWAL



**1X800 MW TANGEDCO NORTH CHENNAI
TPP– (FGD SYSTEM)
HVAC SYSTEM
LIST OF MAKES**

SPECIFICATION NO. PE-TS-485- (571-13000-A)-A001 (REV-0)

SECTION : I

SUB-SECTION : E

REV 00

SHEET 8 OF 15

		SWITZER INSTRUMENT LTD.
32	FLOW SWITCH	SWITZER INSTRUMENT LTD.
		LEVCON
		DK INSTRUMENTS
		SBEM
		V AUTOMAT
		SIEMENS
34	SIGHT FLOW INDICATORS	SIGMA
		LEVCON
		V AUTOMAT
		TELLACE
		EUREKA INDUSTRIAL EQUIPMENTS PVT.LTD.
		TATA HONEYWELL
		BLISS ANAND
		SCIENTIFIC DEVICES
		BK EQUIPMENTS
		INSTRUMENTATION ENGINEERS
35	RH SENSOR/TEMP SENSOR	HONEYWELL AUTOMATION
		JOHNSON
		SIEMENS
		GENERAL INSTRUMENT CONSORTIUM
36	ANNUNCIATOR	ICC
		PECON
		PROCON
37	LT ADAPTER BOX FOR AL TO CU CABLE CONVERTOR	CONTROL DEVICE
		SYSTEM POWER CONTROL
		JACKSON ENGINEERS
		UNILEC
		ELECTRIC ALLIED PRODUCT
38	WATER SOFTENING PLANT	THERMAX
		ION EXCHANGE
		DOSI ION
39	ROTAMETER	CHEMTROLS SAMIL (INDIA) PVT LTD.
		EUREKA INDUSTRIAL EQUIPMENTS PVT.LTD.
		IL
		TRANSDUCERS AND CONTROL



**1X800 MW TANGEDCO NORTH CHENNAI
TPP– (FGD SYSTEM)
HVAC SYSTEM
LIST OF MAKES**

**SPECIFICATION NO. PE-TS-485- (571-13000-
A)-A001 (REV-0)**

SECTION : I

SUB-SECTION : E

REV 00

SHEET 9 OF 15

NOTES:

1. THE SUB VENDOR LIST ABOVE IS INDICATIVE ONLY AND IS SUBJECT TO BHEL AND CUSTOMER APPROVAL DURING DETAILED ENGINEERING STAGE WITHOUT ANY COMMERCIAL & DELIVERY IMPLICATION TO BHEL. BIDDER TO PROPOSE SUB VENDOR WITHIN 4 WEEKS OF PLACEMENT OF LOI. THEREAFTER NO REQUEST FOR ADDITIONAL SUB-VENDOR SHALL BE ENTERTAINED.
2. THE INSPECTION CATEGORY WILL BE INTIMATED AFTER AWARD OF CONTRACT BY BHEL/CUSTOMER. HOWEVER, THE SAME WILL BE ADHERED BY THE BIDDER WITHOUT ANY COMMERCIAL AND DELIVERY IMPLICATION TO BHEL/ CUSTOMER.
3. PLEASE ALSO REFER RESPECTIVE SUB-SECTION C-2, C-3 & C-4 FOR ELECTRICAL, C&I AND HANDLING RELATED EQUIPMENT LIST OF MAKE.



**1X800 MW TANGEDCO NORTH CHENNAI
TPP– (FGD SYSTEM)
HVAC SYSTEM
LIST OF MAKES**

SPECIFICATION NO. PE-TS-485- (571-13000-A)-A001 (REV-0)

SECTION : I

SUB-SECTION : E

REV 00

SHEET 10 OF 15

SL No	ITEM	VENDOR
1	AIR WASHER & UAF*	HYDERABAD POLUTION CONTROL
		SK SYSTEM
		ADVANCE VENTILATION
		DRAFT AIR
		BLUE STAR
		VOLTAS
		STERLING WILSON
		ROOTS COOLING SYSTEM
		C DOCTOR
		TAP
		PACK PLAST
		INDUSTRIAL PROJECTS AND PRODUCTS
2	CENTRIFUGAL FAN	FLAKT
		KRUGER
		DRAFT AIR
		HYDERABAD POLUTION CONTROL
		ADVANCE VENTILATION
		PATEL AIR
		NICOTRA
		SK SYSTEM
		MARATHON
		CB DOCTOR
		SARLA
		COMEFRI
3	FRESH AIR/ SUPPLY/ EXHAUST/ RE UNIT FANS / PROPELLAR	HYDERABAD POLUTION CONTROL
		SK SYSTEM
		ADVANCE VENTILATION
		KRUGER
		NICOTRA
		MARATHON
		FLAKT
		CB DOCTOR
		SARLA (SITAL)
		PATEL AIR
		KHAITAN
		4
JYOTI		
SAM TURBO		
KBL		
KSB		



**1X800 MW TANGEDCO NORTH CHENNAI
TPP– (FGD SYSTEM)
HVAC SYSTEM
LIST OF MAKES**

SPECIFICATION NO. PE-TS-485- (571-13000-A)-A001 (REV-0)

SECTION : I

SUB-SECTION : E

REV 00

SHEET 11 OF 15

		M&P
		VOLTAS
		BEACON-WEIR
		WORTHINGTON
		FLOWMORE
		SULZER PUMPS INDIA LTD.
		BHARAT PUMPS & COMPRESSORS LTD
		FLOWSERVE INDIA CONTROL PVT LTD
		V-FLOW PUMPS & SYSTEMS CO
		KISHORE PUMPS
5	LV MOTORS (FLAME PROOF)	SIEMENS
		ABB
		CGL
		MARATHON
		KEC
		BHARAT BIJLEE
		BHARAT ELECTRIC
		NGEF
		JYOTI
		LHP
6	LV MOTORS (NON FLAME PROOF)	SIEMENS
		ABB
		CGL
		MARATHON
		KEC
		BHARAT BIJLEE
		BHARAT ELECTRIC
		NGEF
		JYOTI
		LHP
7	AIR FILTER	PUROLATOR
		FMI
		ANFILCO
		TENACITY
		JOHN FOWLER
		SPECTRUM
		AIR TECH
		PUROMATIC
8	INSULATION MATERIAL	BEARDSHEL
		K-FLEX
		PARAMONT



**1X800 MW TANGEDCO NORTH CHENNAI
TPP– (FGD SYSTEM)
HVAC SYSTEM
LIST OF MAKES**

SPECIFICATION NO. PE-TS-485- (571-13000-A)-A001 (REV-0)

SECTION : I

SUB-SECTION : E

REV 00

SHEET 12 OF 15

		ARMAFLEX
		SUPREME
		LLOYDS
		UP TWIGA
		AEROCELL
9	FIRE DAMPER	TSC
		CARRYAIRE
		RAVISTAR (SYSTEM AIR)
10	BUTTERFLY VALVES	AUDCO
		FOURESS ENGG
		INTER VALVE
		BDK
		WEIR BDK
		TYCO
		CRANE PROCESS
		KEYSTONE
		FLUIDLINE
		INSTRUMENTATION LTD
		R AND D MULTIPLES (METAL CAST) PVT LTD
		SURYA VALVES AND INSTRUMENTS MFG CO
		PENTAIR VALVES AND CONTROLS INDIA PRIVATE LIMITED
		UPADHAYA VALVES MANUFACTURERS PRIVATE LIMITED
		VENUS PUMPS AND ENGG. WORKS
11	NON RETURN VALVE	LEADER VALVES
		H SARKAR
		FLUIDLINE
		HI-TECH
		CRESCENT VALVES
		A V VALVES
		BANKIM
		SHIVADURGA
		SURYA VALVES AND INSTRUMENT MANUFACTURING
		ATAM VALVES
		GM DAULI & SONS
		KBL
		VENUS PUMPS AND ENGINEERING WORKS
12	STEEL GATE/GLOBE/NR VALVES (WATER SYSTEM)	CRESCENT VALVES
		BDK



**1X800 MW TANGEDCO NORTH CHENNAI
TPP– (FGD SYSTEM)
HVAC SYSTEM
LIST OF MAKES**

SPECIFICATION NO. PE-TS-485- (571-13000-A)-A001 (REV-0)

SECTION : I

SUB-SECTION : E

REV 00

SHEET 13 OF 15

		AUDCO
		FOURESS ENGG
		KIRLOSKAR BROTHERS LTD.
		SANT VALVES
		BOMBAY METAL & ALLOYS
		BANKIM
		LEADER VALVES
		H SARKAR
		AV VALVES
		VENUS PUMPS
		FLUIDLINE
		HI –TECH
		SHIVADURGA
		SURYA VALVES AND INSTRUMENT MANUFACTURING
		ATAM VALVES
		GM DAULI & SONS
		KBL
13	Pipes (MS/GI) - ERW	SURYA ROSHNI
		TISCO
		DADU PIPES
		INDUS TUBES
		WELSPUN
		TATA
		BST
		JINDAL
		SAIL
		PSL
		LALIT PROFILE
		SAMSHI PIPE INDUSTRIES
		S MUKUT PIPES
		MANN INDUSTRIES
		SURENDRA ENGINEERING
		PRATIBHA PIPES AND STRUCTURES PVT LTD
		JCO GAS PIPES
		NUKAT TANK AND VESSELS
		GOODLUCK TUBES
		ADVANCE STEEL TUBES
		BIHAR TUBES
		HITECH PIPES
		RATNAMANI



**1X800 MW TANGEDCO NORTH CHENNAI
TPP– (FGD SYSTEM)
HVAC SYSTEM
LIST OF MAKES**

**SPECIFICATION NO. PE-TS-485- (571-13000-
A)-A001 (REV-0)**

SECTION : I

SUB-SECTION : E

REV 00

SHEET 14 OF 15

14	GI SHEETS FOR DUCTING	MAHARASHTRA SEAMLESS
		TISCO
		INDIAN IRON & STEEL CO
		RASHTRIYA ISPAT NIGAM LIMITED
		ESSAR
		ISPAT INDUSTRIES
		JSW
		LLOYDS
		BHUSHAN STEELS
		TATA
		SAIL
		JINDAL
15	GRILL/DIFFUSER/VOLUME CONTROL DAMPER	AIR FLOW
		TSC
		AIR MASTER
		CARRYAIRE
		RAVISTAR (SYSTEM AIR)
16	HUMID STAT	JHONSON CONTROL
		HONEYWELL AUTOMATION
		PENN
20	PRESSURE/ DP/ VACUUM/ TEMPERATURE SWITCH	BELLS CONTROLS LTD
		DANFOSS
		DK INSTRUMENTS
		DRESSER
		SOR INC
		VASU
		SWITZER INSTRUMENT LTD.
		INDFOSS
		TRAFAG
		GIC
		ASHCROFT INDIA PVT LTD.
		KASTURBA UDYOG
		BARKSDALE GMBH
		PRECISION MASS PRODUCTS
MITTAL REFRIGERATION		
23	Y / POT STRAINER	MULTITEX
		GREAVES COTTON
		JAYPEE
		SANT VALVES
		OTOKLIN
		GRAND PRIX



**1X800 MW TANGEDCO NORTH CHENNAI
TPP– (FGD SYSTEM)
HVAC SYSTEM
LIST OF MAKES**

SPECIFICATION NO. PE-TS-485- (571-13000-A)-A001 (REV-0)

SECTION : I

SUB-SECTION : E

REV 00

SHEET 15 OF 15

		GUJARAT OTOLIFT
		DS ENGG
		SAROJINI ENTERPRISE
		BHATIA ENGINEERING
		FILTRATION ENGINEERS INDIA PVT LTD
		SUNGOV ENGINEERING
24	LOCAL CONTROL PANEL	INDUSTRIAL CONTROL & APPLIANCE
		PYROTECH ELECTRONICS PVT. LTD.
		POSITRONICS PVT. LTD.
		CONTROL & SWITCHGEAR
		SIEMENS
		L&T
		GE POWER
		RITTAL
		HOFFMAN

NOTES:

1. *Designed by Hyderabad Pollution Control / SK SYSTEM/ ADVANCE VENTILATION / DRAFT AIR/BLUE STAR/ VOLTAS/ STERLING WILSON/ROOTS COOLING SYSTEM/ C DOCTOR/ TAP/ Pack Plast/ Industrial projects and products & fabricated by their approved fabricator.

2. THE SUB VENDOR LIST ABOVE IS INDICATIVE ONLY AND IS SUBJECT TO BHEL AND CUSTOMER APPROVAL DURING DETAILED ENGINEERING STAGE WITHOUT ANY COMMERCIAL & DELIVERY IMPLICATION TO BHEL. BIDDER TO PROPOSE SUB VENDOR WITHIN 4 WEEKS OF PLACEMENT OF LOI. THEREAFTER NO REQUEST FOR ADDITIONAL SUB-VENDOR SHALL BE ENTERTAINED.

3. THE INSPECTION CATEGORY WILL BE INTIMATED AFTER AWARD OF CONTRACT BY BHEL/CUSTOMER. HOWEVER, THE SAME WILL BE ADHERED BY THE BIDDER WITHOUT ANY COMMERCIAL AND DELIVERY IMPLICATION TO BHEL/ CUSTOMER.

4. PLEASE ALSO REFER RESPECTIVE SUB-SECTION C-2, C-3 & C-4 FOR ELECTRICAL, C&I AND HANDLING RELATED EQUIPMENT LIST OF MAKE.



**1x800 MW TANGEDCO NORTH CHENNAI
TPP- (FGD SYSTEM)
HVAC SYSTEM
MANDATORY SPARE LIST**

**SPECIFICATION NO. PE-TS-485- (571-13000-
A)-A001 (REV-0)**

SECTION : I

SUB-SECTION : E

REV 00

SHEET 1 OF 3

**SECTION-I
SUB SECTION -E**

**ANNEXURE-II
MANDATORY SPARES LIST**



**1x800 MW TANGEDCO NORTH CHENNAI
TPP– (FGD SYSTEM)
HVAC SYSTEM
MANDATORY SPARE LIST**

SPECIFICATION NO. PE-TS-485- (571-13000-A)-A001 (REV-0)

SECTION : I

SUB-SECTION : E

REV 00

SHEET 2 OF 3

MANDATORY SPARES

NAME OF PROJECT:		1x800 MW TANGEDCO NORTH CHENNAI TPP– (FGD SYSTEM)
NAME OF PACKAGE:		HVAC FOR FGD
TECHNICAL SPECIFICATION No:		PE-TS-485-(571-13000-A)-A001
SL NO	DESCRIPTION	QTY
1.21.0	AIR CONDITIONING AND VENTILATION SYSTEM	
1	Air handling unit (for each model)	
1.1	V-belts for AHU Blower	2 Sets
1.2	AHU Blower bearing	1 Set
1.3	Blower motor bearing	1 Set
1.4	Filters at suction and discharge of all AHUs	25% of installed population
2	Unitary air filtration unit	
2.1	Supply Air fans	
2.1.1	V-belts for supply air fans	2 Sets
2.1.2	Supply air fan bearings	1 Set
2.2	UAF Pump	
2.2.1	Pump bearings	1 Set
2.2.2	Impeller for pump	1 no.
2.2.3	Pump Shaft	1 no.
2.2.4	Shaft sleeves	1 Set
2.2.5	Gland Packings for pumps	1 Set
2.2.6	Nylon Filter	1 Set
2.2.7	Spray nozzles	5% of total population or 50 Numbers whichever is higher.
2.2.8	Water strainer	1 No.
2.2.9	Brass suction screen/strainer for unitary air filtration tank.	1 Set
2.2.10	Motor for Centrifugal fan for UAF	1 No
3	Control & Instrumentation	
i)	Air-Conditioning System	
3.1	Electronic Transmitters	
3.1.1	Transmitters of all types and model no. (for the measurement of Pressure, differential pressure flow, level, temperature etc.)	5% or 1 No. of each type and model whichever is more. (to be divided into various ranges in proportion to main population)



**1x800 MW TANGEDCO NORTH CHENNAI
 TPP– (FGD SYSTEM)
 HVAC SYSTEM
 MANDATORY SPARE LIST**

SPECIFICATION NO. PE-TS-485- (571-13000-A)-A001 (REV-0)

SECTION : I

SUB-SECTION : E

REV 00

SHEET 3 OF 3

3.2	Temperature elements	
	RTD's	5% or 1 No. whichever is more **
	Thermo well	5% or 1 No. whichever is more **
	* (With head assembly, terminal block and nipple)	** (to be divided into various insertion lengths in proportion to main population)
	All types of Local Indicators	5% or 1 No. of each make, model and type whichever is more (to be divided to various ranges in proportion to main population of all make, model and type)
	Process Actuated Switch Devices Includes all types of Pressure, differential pressure, flow, and temperature, and differential temperature, level switch Devices.	5% or 1No. of each type and model whichever is more.
	Relative Humidity Sensors	1 No.
	Geysterstat	1 No.
	Local Humidity/Temperature indicators	2 Nos. each
4	Process Connection Piping (for Impulse Piping / Tubing, Sampling Piping / Tubing and Air Supply Piping as Applicable)	
4.1	Valves	10% or 1 No. of each type, class, size and model whichever is more
4.2	2 way, 3way, 5way valve manifolds	2 way, 3way, 5way valve manifolds
4.3	Fittings	2 way, 3way, 5way valve manifolds
	(II) Ventilation System	
5	Measuring Instruments	
5.1	Pressure gauge	1 No. (for centrifugal pumps of UAF units).
5.2	Level transmitter	1 No. (for UAF units)
5.3	Pressure transmitter	1 No. (for UAF Units)
6	Process Connection Piping (for Impulse Piping / Tubing, Sampling Piping / Tubing and Air Supply Piping as Applicable)	
6.1	Valves	1 no. of each type, class, size and Model
6.2	2 way valve manifold	1 no. of each type, class, size and model
6.3	Fittings	1 no. of each type, class, size and model



**1x800 MW TANGEDCO NORTH CHENNAI
TPP- (FGD SYSTEM)
HVAC SYSTEM
PAINTING & COLOUR SCHEME**

**SPECIFICATION No: PE-TS-485- (571-13000-
A)-A001 (REV-0)**

SECTION : I

SUB-SECTION : E

REV 00

SHEET 1 OF 2

**SECTION-I
SUB SECTION E
ANNEXURE-III
PAINTING & COLOUR SCHEME
(REFER SECTION C2)**



**1x800 MW TANGEDCO NORTH CHENNAI
TPP– (FGD SYSTEM)
HVAC SYSTEM
PAINTING & COLOUR SCHEME**

SPECIFICATION No: PE-TS-485- (571-13000-A)-A001 (REV-0)

SECTION : I

SUB-SECTION : E

REV 00

SHEET 2 OF 2

- For painting please refer the section C2.
- Color shall be as per IS 5.



**1x800 MW TANGEDCO NORTH CHENNAI
TPP– (FGD SYSTEM)
HVAC
LIST OF TOOLS & TACKLES**

**SPECIFICATION No: PE-TS-485- (571-13000-
A)-A001 (REV-0)**

SECTION : I

SUB SECTION : E

REV 00

ANNEXURE-IV

LIST OF TOOLS & TACKLES
REFER SUGGESTIVE PRICE FORMAT



**1X800 MW TANGEDCO NORTH CHENNAI
TPP- (FGD SYSTEM)
HVAC SYSTEM
MASTER DRAWING LIST WITH SCHEDULE
OF SUBMISSION**

**SPECIFICATION No: PE-TS-485- (571-13000-
A)-A001 (REV-0)**

SECTION : I

SUB-SECTION : E

REV 00

SHEET 1 OF 4

SECTION-I

SUB-SECTION-E

ANNEXURE-V

MASTER DRAWING LIST WITH SCHEDULE OF SUBMISSION

MDL (MASTER DRAWING LIST)- 1X800 MW NORTH CHENNAI TPS (FGD PKG)

HVAC SYSTEM FOR FGD

Sr. No.	Drg Title	Submission Schedule Date (in weeks from date of LOI)
1	ITEM CATEGORISATION AND SUB VENDOR LIST FOR HVAC SYSTEM	2
2	MQP OF CONDENSING UNIT FOR HVAC SYSTEM	6
3	MQP OF AHU FOR HVAC SYSTEM	6
4	MQP OF CENTRIFUGAL FAN FOR HVAC SYSTEM	6
5	MQP OF UAF FOR HVAC SYSTEM	6
6	MQP OF FILTERS FOR HVAC SYSTEM	6
7	MQP OF THERMAL / ACOUSTIC INSULATION FOR HVAC SYSTEM	6
8	MQP OF CENTRIFUGAL PUMPS FOR UAF	6
9	MQP OF PIPE FOR HVAC SYSTEM	6
10	MQP OF VALVE FOR HVAC SYSTEM	6
11	MANUFACTURING QUALITY PLAN FOR CPB	6
12*	HEAT LOAD CALCULATION FOR A/C SYSTEM OF FGD CONTROL BUILDING	2
13	P & I DIAGRAM FOR AIR COOLED CONDENSING UNIT (DX- TYPE) FOR FGD CONTROL BUILDING	4
14*	HEAT LOAD CALCULATION FOR EVAPORATIVE COOLING SYSTEM OF FGD BUILDING	2
15	P&ID FOR UAF UNIT FOR FGD BUILDING	4
16	SCHEME OF AIR DISTRIBUTION IN FGD BUILDING	4
17*	TECHNICAL DATA SHEET OF CENTRIFUGAL FANS FOR AIR HANDLING UNITS AND UAF UNITS	5
18*	TECHNICAL DATA SHEET & GA OF AIR HANDLING UNITS	5
19*	TECHNICAL DATA SHEET & GA DRAWING OF UAF UNIT	5
20*	TECHNICAL DATA SHEET & GA DRAWING FOR CENTRIFUGAL PUMP FOR UAF UNIT	5
21	TECHNICAL DATA SHEET FOR STRAINER OF VENTILATION SYSTEM	6
22	TECHNICAL DATA SHEET & G.A. DRWG. FOR CAST IRON VALVES(GATE VALVE,CHECK VALVE, GLOBE VALVE) OF VENTILATION SYSTEM	6
23	TECHNICAL DATA SHEET & G.A.DRWG. FOR BUTTERFLY VALVE	6
24	TECHNICAL DATA SHEET & G.A. DRAWING OF FIRE DAMPER WITH ACTUATOR FOR A/C & VENTILATION SYSTEM	6
25*	TECHNICAL DATA SHEET & G.A DRAWING OF AIR-COOLED CONDENSING UNIT FOR FGD CONTROL BUILDING	5
26	TECHNICAL DATA SHEET & G.A. DRAWING FOR HEATER PACKAGE AND PAN HUMIDIFIER	5
27*	TECHNICAL DATA SHEET & G.A. DRAWING OF AXIAL AIR FANS FOR A/C & VENTILATION SYSTEM ALONGWITH FIXING DETAILS AND GA OF PROPELLER FAN	5
28	GA OF SUPPLY/RETURN AIR DIFFUSER/GRILL FOR A/C & VENTILATION SYSTEM	5
29	TECHNICAL DATA SHEET FOR SPLIT AIR CONDITIONERS	4
30	TECHNICAL DATA SHEET FOR THERMAL & ACCOUSTIC INSULATION FOR A/C & VENTILATION SYSTEM	5
31	TECHNICAL DATA SHEET OF GI SHEET FOR AC AND VENTILATION SYSTEM	5
32	TECHNICAL DATA SHEET AND GA OF FILTERS FOR AC AND VENTILATION SYSTEM	6
33	TECHNICAL DATA SHEET OF PIPE FOR VENTILATION SYSTEM	6
34	TECHNICAL DATA SHEET FOR INSTRUMENTS (PRESSURE GAUGE, TEMPERATURE GAUGE, LEVEL GAUGE ETC) FOR AC AND VENTILATION SYSTEM	8

35	TECHNICAL DATA SHEET AND GA OF MOTOR (PUMP, AHU, UAF, AXIAL FAN)	6
36	GA DRAWING FOR CPB WITH DETAIL BOM WITH PAINTING DETAILS	8
37*	A/C EQUIPMENT LAYOUT (AHU & OUTDOOR UNITS) WITH COMPLETE FOUNDATION DETAIL AND A/C DUCT LAYOUT FOR FGD CONTROL BUILDING	6
38*	EQUIPMENT LAYOUT OF UAF UNIT ALONGWITH FOUNDATION DETAIL AND AND VENTILATION DUCT LAYOUT FOR FGD BUILDING	6
39	VENT. ARRANGEMENT FOR VARIOUS AUXILIARY BUILDING	6
40	STANDARD DRAWING FOR DUCT FABRICATION & SUPPORTING ARRANGEMENT AND ERECTION & APPLICATION DETAIL OF INSULATION	8
41	SPLIT AC SCHEDULE ALONGWITH HEAT LOAD CALCULATION FOR AUXILIARY BUILDING OF AC SYSTEM	6
42	VENTILATION FAN SCHEDULE	5
43	WRITE-UP & CONTROL PHILOSOPHY FOR A/C AND VENTILATION SYSTEM	8
44	PG TEST PROCEDURE FOR A/C & VENTILATION SYSTEM	10
45*	OPERATION & MAINTENANCE MANUAL FOR A/C & VENTILATION SYSTEM	12
46	CABLE SCHEDULE FOR HVAC SYSTEM	12
47	FEEDER LIST WITH INTERCONNECTION DIAGRAM FOR HVAC SYSTEM	10
48	IO & DRIVE LIST FOR HVAC SYSTEM	10
49	CONTROL LOGIC DIAGRAM FOR HVAC SYSTEM	10
50	TDS OF JUNCTION BOX FOR AIR CONDITIONING SYSTEM	10

	1X800 MW TANGEDCO NORTH CHENNAI TPP– (FGD SYSTEM) HVAC SYSTEM MASTER DRAWING LIST WITH SCHEDULE OF SUBMISSION	SPECIFICATION No: PE-TS-485- (571-13000-A)-A001 (REV-0)	
		SECTION : I	
		SUB-SECTION : E	
		REV 00	
		SHEET 2 OF 4	

Notes:

1. The above drawing list is tentative and shall be finalized with the successful bidder after placement of order. While some of the drawings indicated above may not be applicable, some additional drawings may also be required based on scope of work.
2. Drawings shall be prepared in Auto-Cad latest edition. Required no. of hard and soft copies (editable) of the drawings shall be furnished as per requirement specified elsewhere in the specification.
3. Only manual calculation with authentic supporting literature (e.g. extracts of hand Book/ standard/codes) shall be acceptable. All design calculations and drawings shall be in SI system only.
4. All the drawings and documents including general arrangement drawing, data sheet, calculation etc. to be furnished to the customer during detailed engineering stage shall include / indicate the following details for clarity w.r.t. Inspection, construction, erection and maintenance etc.: -
 - a) All drawings and documents shall indicate the list of all reference drawings including general arrangement.
 - b) All drawings shall include / show plan, elevation, side view, cross - section, skin section, blow - up view; all major self-manufactured and bought out items shall be labeled and included in BOQ / BOM in tabular form.
 - c) Painting schedule shall also be made as a part of general arrangement drawing of each equipment / items indicating at least 3 trade names.
 - d) All the drawings required to be furnished to customer during detailed engineering stage shall include technical parameters, details of paints and lubrication, hardness and BOQ / BOM in tabular form indicating all major components including bought out items and their quantity, material of construction indicating its applicable code / standard, weight, make etc.
 - e) Drawings/ documents to be submitted for purchaser's review/ approval shall be under Revision A, B, C... etc. while drawings /documents to be submitted thereafter for customer's approval after purchaser's approval shall be under R-0, 1, 2, 3 etc.
 - f) Drawings and documents not covered above but required to check safety of machines/ system, shall be submitted during detailed engineering stage without any commercial implication.
 - g) All drawings shall include "B.O.M" and indicate quantity, material of construction, make along with IS/BS No., Technical parameters, dimensions, hardness, machining symbol and tolerance, requirement of radiography and hydraulic tests, painting details, elevation, side view, plan, skin section and blow-up view for clarity.
 - h) All drawings shall be prepared as per BHEL's title block and shall bear BHEL's drawing No.
 - i) Schedule of drawings submissions, comment incorporations & approval shall be as stipulated in the specifications. The successful bidder shall depute his design

	1X800 MW TANGEDCO NORTH CHENNAI TPP– (FGD SYSTEM) HVAC SYSTEM MASTER DRAWING LIST WITH SCHEDULE OF SUBMISSION	SPECIFICATION No: PE-TS-485- (571-13000- A)-A001 (REV-0)	
		SECTION : I	
		SUB-SECTION : E	
		REV 00	
		SHEET 3 OF 4	

personnel to BHEL's/ Customer's/ Consultant's office for across the table resolution of issues and to get documents approved in the stipulated time.

- j) Bidder to follow the following the drawing submission schedule:
- k) 1st submission of drawings from date of LOI as per the submission schedule.
- l) Every revised submission incorporating comments – within 7 days.
- m) Bidder to submit revised drawings complete in all respects incorporating all comments. Any incomplete drawing submitted shall be treated as non-submission with delays attributable to bidder's account. For any clarification/ discussion required to complete the drawings, the bidder shall himself depute his personal to BHEL for across the table discussions/ finalizations/ submissions of drawings.
- n) Documents marked with '*' in the above MDL shall be considered as Basic Engineering Documents.



**1x800 MW TANGEDCO NORTH CHENNAI
TPP- (FGD SYSTEM)
HVAC SYSTEM
FORMAT FOR OPERATION AND
MAINTENANCE MANUAL**

**SPECIFICATION No: PE-TS-485- (571-13000-
A)-A001 (REV-0)**

SECTION : I

SUB-SECTION : E

REV 00

SHEET 1 OF 4

**SECTION-I
SUB-SECTION-E
ANNEXURE-VI
FORMAT FOR OPERATION AND MAINTENANCE
MANUAL**



**1x800 MW TANGEDCO NORTH CHENNAI
TPP– (FGD SYSTEM)
HVAC SYSTEM
FORMAT FOR OPERATION AND
MAINTENANCE MANUAL**

SPECIFICATION No: PE-TS-485- (571-13000-A)-A001 (REV-0)

SECTION : I

SUB-SECTION : E

REV 00

SHEET 2 OF 4

Project name :
Project number :
Package Name :
PO reference :
Document number :
Revision number :

Sl.no. & Sections	Description	Tick (√)if included in Manual			Remarks
		Yes	No	Not Applicable	
1.	COVER PAGE				
1.1	Project Name				
1.2	Customer/consultant Name				
1.3	Name of Package				
1.4	Supplier details with phone, FAX ,email address , Emergency Contact number				
1.5	Name and sign of prepared by , checked by & approved by				
1.6	Revision history with approval Details				
2.0	INDEX				
2.1	showing the sections & related page nos All the pages should be numbered section wise				
3.0	DESCRIPTION OF PLANT/SYSTEM				
3.1	Description /write up of operating principle of system equipment/ associated sub-systems & accessories/controls system , operating conditions, performance parameters under normal , start up and special cases				
3.2	Equipment list and basic parameter with Tag numbers				
3.3	Data sheets approved by Customer/for information and catalogues provided by original manufacturer				
3.4	Associated other packages and Interface /terminal points				
3.5	P&ID & Process Diagrams				
3.6	GA Layout drawings, As-built drawings , Actual photograph of items/system (Drawings of A2 & bigger sizes are to be attached in the last)				
3.7	Single line/wiring diagrams				
3.8	Control philosophy /control write-ups				



**1x800 MW TANGEDCO NORTH CHENNAI
TPP– (FGD SYSTEM)
HVAC SYSTEM
FORMAT FOR OPERATION AND
MAINTENANCE MANUAL**

SPECIFICATION No: PE-TS-485- (571-13000-A)-A001 (REV-0)

SECTION : I

SUB-SECTION : E

REV 00

SHEET 3 OF 4

Sl.no. & Sections	Description	Tick (√)if included in Manual			Remarks
		Yes	No	Not Applicable	
4.0	COMMISSIONING ACTIVITIES (IF NOT COVERED IN SEPARATE DOCUMENT I.E. ERECTION MANUAL, COMMISSIONING MANUAL)				
4.1	Pre-Commissioning Checks				
4.2	handling of items at site				
4.3	Storage at site				
4.4	Unpacking & Installation procedure				
5.0	OPERATION GUIDELINES FOR PLANT PERSONAL/USER/OPERATOR				
5.1	Interlock & Protection logic along with the limiting values of protection settings for the equipment along with brief philosophy behind the logic, drawings etc. to be provided.				
5.2	Start up, normal operation and shut down procedure for equipments along with the associated systems in step by step mode. Valve sequence chart, step list, interlocks etc. with Equipment isolating procedures to be mentioned.				
5.3	Do's & Don't of the equipments.				
5.4	Safety precautions to be taken during normal operation. Safety symbols, Emergency instructions on total power failure condition/lubrication failure/any other condition				
5.5	Parameters to be monitored with normal values and limiting values				
5.6	Trouble shooting with causes and remedial measures				
5.7	Routine operational checks, recommended logs & records				
5.8	Changeover schedule if more than one auxiliary for the same purpose is given				
5.9	Painting requirement and schedule				
5.10	Inspection, repair , Testing and calibration procedures				
6.0	MAINTENANCE GUIDELINES FOR PLANT PERSONAL				



**1x800 MW TANGEDCO NORTH CHENNAI
TPP– (FGD SYSTEM)
HVAC SYSTEM
FORMAT FOR OPERATION AND
MAINTENANCE MANUAL**

SPECIFICATION No: PE-TS-485- (571-13000-A)-A001 (REV-0)

SECTION : I

SUB-SECTION : E

REV 00

SHEET 4 OF 4

Sl.no. & Sections	Description	Tick (√)if included in Manual			Remarks
		Yes	No	Not Applicable	
6.1	List of Special Tools and Tackles required for Overhaul/Trouble shooting including special testing equipment required for calibration etc.				
6.2	Stepwise dismantling and re-assembly procedure clearly specifying the tools to be used, checks to be made, records to be maintained, clearances etc. to be mentioned. Tolerances for fitment of various components to be given.				
6.3	Preventive Maintenance & Overhauling schedules linked with running hours/calendar period along with checks to be given				
6.4	Long term maintenance schedules especially for structural, foundations etc.				
6.5	Consumable list along with the estimated quantity required during commissioning, normal running and during maintenance like Preventive Maintenances and Overhaul. Storage/handling requirement of consumables/self-life.				
6.6	List of lubricants with their Indian equivalent, Lubrication Schedule, Quantity required for each equipment for complete replacement is to be given				
6.7	List of vendors & Sub-vendors with their latest addresses, service centres ,Telephone Nos., Fax Nos., Mobile Nos., e-mail IDs etc.				
6.8	List of mandatory and recommended spare parts list				
6.9	Tentative Lead time required for ordering of spares from the equipment supplier				
6.10	Guarantee and warranty clauses				
7.0	Statutory and other specific requirements considerations.				
8.0	List of reference documents				
9.0	Binding as per requirement				



**1x800 MW TANGEDCO NORTH CHENNAI
TPP– (FGD SYSTEM)
HVAC SYSTEM
SITE STORAGE AND PRESERVATION**

**SPECIFICATION No: PE-TS-485- (571-13000-
A)-A001 (REV-0)**

SECTION : I

SUB-SECTION : E

REV 00

**SECTION-I
SUB-SECTION-E
ANNEXURE-VII
SITE STORAGE AND PRESERVATION**

SITE STORAGE AND PRESERVATION GUIDELINES FOR MECHNANICAL BOPs

(Doc No: PE-DC-SSG-A001 REV.00)



PROJECT ENGINEERING MANAGEMENT, POWER SECTOR
BHARAT HEAVY ELECTRICALS LIMITED-NOIDA

CONTENT

- 1 SCOPE OF THE DOCUMENT
- 2 PURPOSE OF STORAGE & PRESERVATION
- 3 MEASURES TO BE TAKEN FOR STORAGE AND PRESERVATION
 - a) GENERAL STORAGE REQUIREMENTS
 - b) GENERAL PRESERVATION REQUIREMENTS
 - c) GENERAL INSPECTION REQUIREMENTS
- 4 TYPE OF STORAGE FOR VARIOUS EQUIPMENT
5. CONCLUSION
6. STACKING ARRANGEMENT FOR PLATES AND STRUCTURAL STEEL

1. SCOPE OF THE DOCUMENT

This guideline is prepared in intent to provide proper site storage and preservation of the Mechanical, Electrical and C & I items / equipment supplied under various bought out packages/items. This storage procedure shall be followed at different power plant sites by concerned agency for storage and preservation from the date of equipment received at site until the same are erected and handed over to the customer.

2. PURPOSE OF STORAGE & PRESERVATION

Many of the items may be required to be kept in stores for long period. It shall therefore be essential that proper methods of storage and preservation be applied so that items do not deteriorate, loose some of their properties and become unusable due to atmospheric conditions and biological elements.

3. MEASURES TO BE TAKEN FOR STORAGE, HANDLING & PRESERVATION

a) GENERAL STORAGE REQUIREMENTS

1. To the extent feasible, materials should be stored near the point of erection. The storage areas should have adequate unloading and handling facilities with adequate passage space for movement of material handling equipment such as cranes, fork lift trucks, etc. The storage of materials shall be properly planned to minimise time loss during retrieval of items required for erection.
2. The outdoor storage areas as well as semi-closed stores shall be provided with adequate drainage facilities to prevent water logging. Adequacy of these facilities shall be checked prior to monsoon.
3. The storage sheds shall be built in conformity with fire safety requirements. The stores shall be provided with adequate lights and fire extinguishers. 'No smoking' signs shall be placed at strategic locations. Safety precautions shall be strictly enforced.
4. Adequate lighting facility shall be provided in storage areas and storage sheds and security personnel positioned to ensure enforcement of security measures to prevent theft and loss of materials.
5. Adequate number of competent stores personnel and security staff shall be deployed to efficiently store and maintain the equipment / material.
7. The equipment shall be stored in an orderly manner, preserving their identification slips, tags and instruction booklets, etc., required during erection. The storage of materials shall be equipment-wise. Loose parts shall be stored in sheds on racks,

preserving the identification marks and tags in good condition. The group codes shall be displayed on the racks

6. At no time shall any materials be stored directly on ground. All materials shall be stored minimum 200 mm above the ground preferably on wooden sleepers

b) GENERAL PRESERVATION REQUIREMENTS

1. All special measures to prevent corrosion shall be taken like keeping material in dry condition, avoiding the equipment coming in contact with corrosive fluid like water, acid etc.
2. Materials which carry protective coating shall not be wrapped in paper, cloth, etc., as these are liable to absorb and retain moisture. The material shall be inspected and in case of signs of wear or damages to protective coating, that portion shall be cleaned with approved solution and coated with an approved protective paint. Complete record of all such observations and protective measures taken shall be maintained.
3. Generally equipment supplied at site are properly greased or rust protective oil is applied on machined/ fabricated components. However periodic inspection shall be carried out to ensure that protection offered is intact.
4. While handling the equipment, no dragging on the ground is permitted. Avoid using wire rope for lifting coated components. Use polyester slings (if possible) otherwise protective material (e.g. clothes, wood block etc.) should be used while handling the components with rope / slings
5. For Equipment supplied with finished paint, touch paint shall be done in case any surface paint gets peeled off during handling. Otherwise such surfaces shall necessarily be wrapped with polythene to avoid any corrosion. Further for equipment wherein finish coat is to be applied at site, site to ensure that equipment is received with primer coat applied.
6. It shall be ensured by periodic inspection that plastic inserts are intact in tapped holes, wherever applicable.
7. Pipes shall be blown with air periodically and it shall be ensured that there is no obstruction.
8. Silica gel or approved equivalent moisture absorbing material in small cotton bags shall be placed and tied at various points on the equipment, wherever necessary.
9. Heavy rotating parts in assembled conditions shall be periodically rotated to prevent corrosion/jamming due to prolonged storage.

10. All the electrical equipment such as motors, generators, etc. shall be tested for insulation resistance at least once in three months and a record of such measured insulation values shall be maintained.
11. Following preservatives/preservation methods can be used depending upon type of equipment
 - a. Rust preventive fluid (RPF)
 - b. Rust protective paints
 - c. Tarpaulin covers, in case of outdoor storage
 - d. De-oxy aluminate for weld-ments

c) GENERAL INSPECTION REQUIREMENTS

1. Period inspection of materials with specific reference to –
 - Ingress of moisture and corrosion damages.
 - Damage to protective coating.
 - Open ends in pipes, vessels and equipment -
 - In case any open ends are noticed, same shall be capped.
2. Any damages to equipment / materials.
 - In case of any damages, these shall be promptly notified and in all cases, the repairs / rectification shall be carried out.
 - Any items found damaged or not suitable as per project requirements shall be removed from site. If required to store temporarily, they shall be clearly marked and stored separately to prevent any inadvertent use.

4. TYPE OF STORAGE FOR VARIOUS EQUIPMENT

The types of storage are broadly classified under the following heads:

i **Closed storage with dry and dust free atmosphere. (C)**

The closed shed can be constructed by using cold-rolled / tubular components for structure and corrugated asbestos sheets / galvanised iron sheets for roofing. Brick walls / asbestos sheets can be used to cover all the sides. The floor of the shed can be finished with plain cement concrete suitably glazed. The shed shall be provided with proper ventilation and illumination.



ii **Semi-closed storage. (S)**

The semi closed shed can be constructed by using cold-rolled / tubular components for structure and corrugated / asbestos sheets for roofing. The floor shall be brick paved. If required a small portion of sides can be covered to protect components from rainwater splashing onto the components.





iii Open storage (O)

The open yard shall be levelled, well consolidated to achieve raised ground with the provision of feeder roads for crane approach along with access roads running all sides. One part of the open yard shall be stone pitched, levelled and consolidated with raised ground suitable for storing / stacking heavier and critical components with due space to handle them by cranes etc . Adequate number of sleepers, concrete block etc. to be provided to make raised platforms to stack critical materials.

A separate yard to be identified as “scrap yard” slightly away from main open yard to store wooden/steel scraps, which are to be disposed off. This is required to avoid mix up with regular components as well as to avoid fire hazard.

Some of the components, which are having both machined & un-machined surfaces and are bulky, shall be stored in open storage area on a raised ground and suitably covered with water proof / fire retardant tarpaulin.



The equipment listed below shall be stored and inspected as per requirement mentioned in the table below.

Sl. No.	Description of the equipment	Type of Storage	Check for	Remarks
Raw material /mechanical items like pipes, plates, structure sections etc.)				
1.	Steel pipes (lined/unlined)	S	Damage , paint, corrosion, rubber lining peeling	Provide end cap
2.	MS Plates	S	Damage, paint, corrosion	
3.	SS Plates	S	Damage	
4.	Non-metallic pipes	S	Damage, cracks	Provide end cap
5.	Stainless steel pipes	S	Damage ,	Provide end cap
6.	MS sections, beams	S	Damage, paint, corrosion	
7.	Cable trays	S	Damage, condition of preservations	
8.	Insulation sheets	S	Damage	
9.	Insulation	C	Damage, packing	
10.	Hangers Rods	S	Damage, paint, packing	
11.	Tubes	S	Damage, paint , packing	Provide end cap
12.	Hume pipes	O	Damage	
13.	Castings	O	Damage, paint, corrosion	
Fabricated mechanical items (pressure vessels, tanks etc.)				
14.	Pressure vessels (unlined)	O	Damage, paint, corrosion,	Covered nozzles
15.	Atmospheric storage tanks (unlined)	O	Damage, paint, corrosion	Covered nozzles

Sl. No.	Description of the equipment	Type of Storage	Check for	Remarks
16.	Pressure vessels (lined)	S	Damage, paint, corrosion, rubber lining	
17.	Atmospheric storage tanks(lined)	S	Damage, paint, corrosion, rubber lining	
18.	Support structures	O	Damage , paint, corrosion	
19.	Flanges	C	Damage , paint, corrosion	
20.	Fabricated pipes	S	Damage , paint, corrosion	Provide end cap
21.	Vessels internals	C	Damage , paint, corrosion ,packing	
22.	Grills	S	Damage , paint, corrosion	
23.	Angles	S	Damage , paint, corrosion	
24.	Bridge mechanism/clarifier mechanism	O	Damage , paint, corrosion	
25.	Cranes, rails	S	Damage , paint, corrosion	
26.	Stair cases	O	Damage , paint, corrosion	
27.	Ladders/handrails	O	Damage , paint, corrosion	
28.	Fabricated ducts	S	Damage , paint, corrosion	
29.	Isolation Gates	O	Damage , paint, corrosion	
30.	Fabricated boxes/panels	S	Damage , paint, corrosion	
Mechanical components like valves, fittings, cables glands, spares etc.)				
31.	Valves	S	Damage , packing	

Sl. No.	Description of the equipment	Type of Storage	Check for	Remarks
32.	Fittings	S	Damage , packing	Provide end cap
33.	Cable glands	C	Damage , packing	
34.	Tools & tackles	C	Damage , packing	
35.	Nut , bolts, washers,	C	Damage , packing	
36.	Gasket & Packings	C	Damage , packing	
37.	Copper tubes	C	Damage , packing, corrosion	Provide end cap
38.	SS tubing	C	Damage , packing	Provide end cap
Rotating assemblies (pumps, blowers, stirrers, fans, compressors etc.)				
39.	Pumps	S	Damage , packing, corrosion	Shaft rotation
40.	Blowers/Compressors	S	Damage , packing, corrosion	Shaft rotation
41.	Agitators/stirrers/radial launders	C	Damage , packing, corrosion	Shaft rotation
42.	Rollers for chlorine tonner mounting	C	Damage , packing, corrosion	
43.	Centrifuge	S	Damage , packing,	
44.	Gear box	C	Damage , packing, corrosion	
45.	Bearings	C	Damage , packing, corrosion	
46.	Fans	S	Damage , packing, corrosion	
47.	Dosing skids	S	Damage , packing, corrosion	
48.	Pump assemblies	S	Damage , packing, corrosion	
49.	Air washers(INTERNALS)	S	Damage , packing	
50.	Air conditioners (split)	C	Damage , packing	

Sl. No.	Description of the equipment	Type of Storage	Check for	Remarks
51.	Elevators(CONTAINERIZED)	O	Damage , packing, corrosion	
52.	Chillers/VA machines	S	Damage , packing	
53.	Air handling Unit/Package unit	S	Damage , packing	
54.	Chlorinators & Evaporators	C	Damage , packing	
55.	Ejectors	C	Damage , packing	
56.	Electrolyser	C	Damage , packing	
Miscellaneous items like chain pulley blocks, hoists etc.				
57.	Chain pulley blocks	S	Damage, Packing	
58.	Electric hoists	S	Damage, Packing	
59.	Fire extinguishers	C	Damage, expiry date	
60.	Fork Lift Truck	S	Damage, Packing	
61.	Hydraulic Mobile Crane	O	Damage, Packing	
62.	Mobile Pick Up & Carry Crane	O	Damage, Packing	
63.	Motor boats	O	Damage, Packing	
64.	Safety showers	S	Damage, Packing	
65.	Diffusers/dampers	S	Damage, Packing	
Chemicals and consumables (acid, alkali, paints, oils, reagents and special chemicals)				
66.	Hydro Chloric Acid (HCl)	Store in canes/ storage tank in dyke area	Date of production/ leakage/fumes	hazardous chemical
67.	Sulphuric acid (H ₂ SO ₄)	Store in canes/ storage tank in dyke area	Date of production/ leakage/fumes	hazardous chemical

Sl. No.	Description of the equipment	Type of Storage	Check for	Remarks
68.	Sodium hydroxide (NaOH)	Store in canes/ storage tank in dyke area	Date of production/ leakage/ fumes/ breather	hazardous chemical ,breather to be checked for air ingress
69.	Sodium hypo chlorite	To be stored under shed	Date of production/ leakage/ fumes	hazardous chemical ,self-life normally 15-30 days after which strength of chemical decays
70.	Ammonia	S	Date of production/ leakage/ fumes	Store in closed storage tanks, hazardous chemical
71.	CW treatment chemicals	S	Date of production , Self-life	Store in closed canes
72.	RO/UF cleaning chemicals	S	Date of production , Self-life	Store in closed canes
73.	Lime	C	Damage to packing , seepage	Prevent moisture, rain
74.	Alum bricks	C	Damage to packing	Prevent moisture, rain
75.	Poly electrolyte	S		Store in closed storage tanks
76.	Laboratory chemicals(powder)	C	Damage, Packing self- life	
77.	Laboratory chemicals(liquid)	C	Damage, Packing self- life	
78.	Lubrication oils	C	Leakage	
79.	Paints	S	Leakage ,air tightness	
80.	Sand	O	Damage of packing	No hooks
81.	Salt (NaCl)	C	Damage of packing, water ingress	Prevent moisture, rain
82.	Anthracite	S	Damage of packing	
83.	Activated carbon	S	Damage of packing	

Sl. No.	Description of the equipment	Type of Storage	Check for	Remarks
84.	Thermal insulation	S	Damage of packing	
85.	Cement	C	Damage of packing	Prevent moisture, rain
86.	Gravels	O	Damage of packing	
87.	ION exchange resins	C	Damage , packing	Refer manufacturer guidelines
88.	RO membranes	C	Damage , packing	Refer manufacturer guidelines
89.	UF membranes	C	Damage , packing	Refer manufacturer guidelines
90.	Cleaning chemicals	C	Damage , packing	Refer manufacturer guidelines
91.	Chemicals for analysers/calibration	C	Damage , packing	Refer manufacturer guidelines
Electrical and C & I items (motors, cables etc.)				
92.	Motors	C	Damage , packing	
93.	Cable drums	O	Damage	
94.	Control Panel /control desk, UPS ,JB	S	Damage, Packing	
95.	Instruments(gauges/analysers)	C	Damage	
Special items		As per Manufacturer's item, like Hydrogen cylinders, Ozonator, Analyser, Chlorine dioxide generators etc.		

5. CONCLUSION

Concerned storage agency at site should make sure that loss in equipment performance and wear & tear are minimised through proper storage and preservation. The above are broad guidelines and cover major equipment / materials. However specific storage practices shall be followed as per manufacturer recommendation. All the necessary measures even in addition to the ones mentioned above, if found necessary, should be taken to achieve the objective.

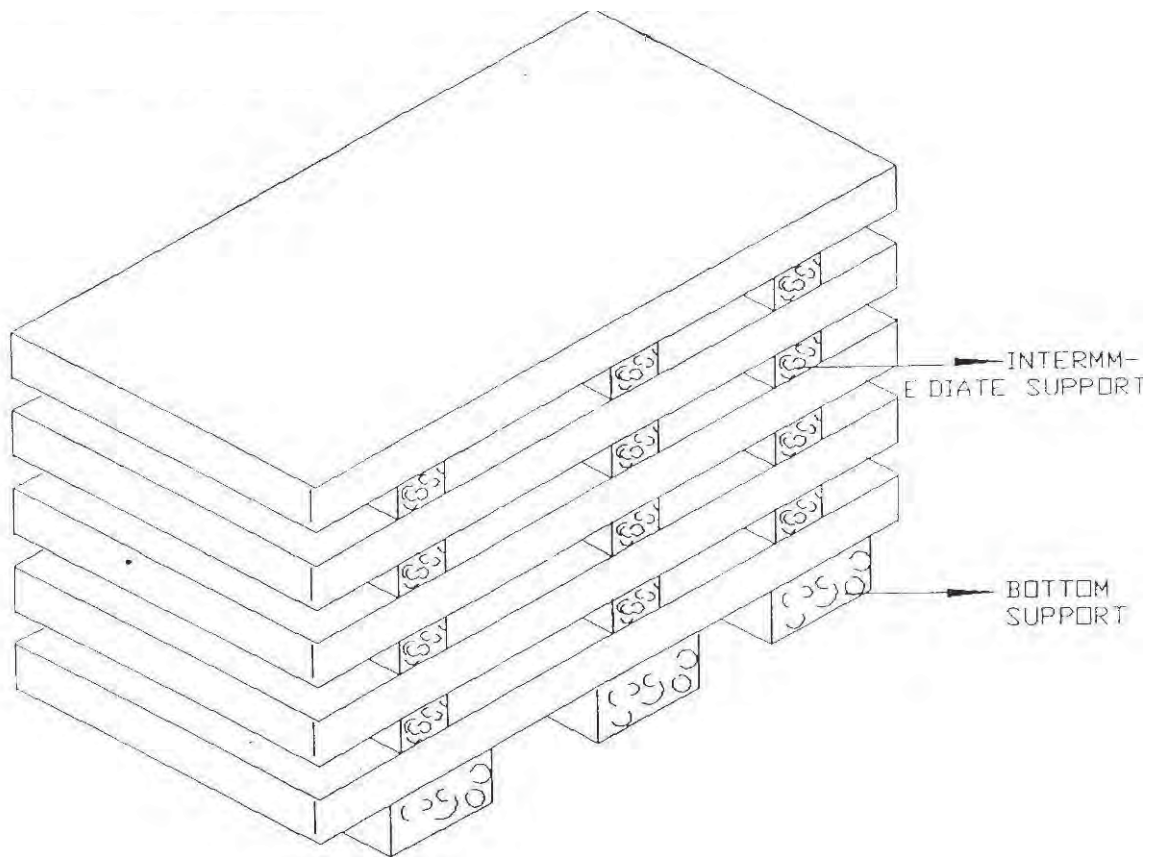

Figure - 1 - PLATE STACKING ARRANGEMENT

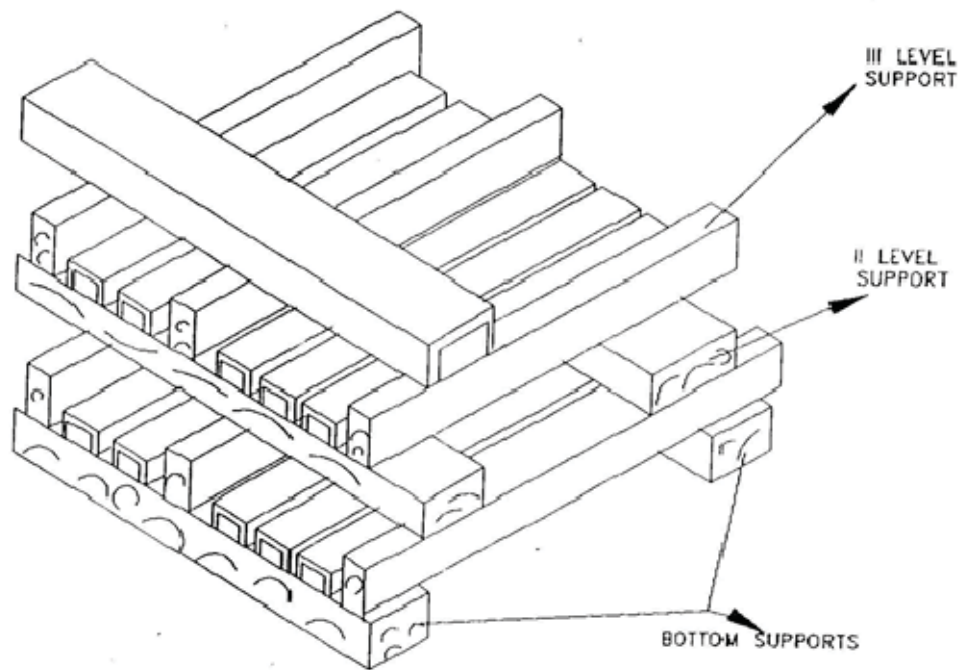

Figure - 2 - STRUCTURAL STEEL STACKING ARRANGEMENT



**1x800 MW TANGEDCO NORTH CHENNAI
TPP– (FGD SYSTEM)
HVAC SYSTEM**

**SPECIFICATION No: PE-TS-485- (571-13000-
A)-A001 (REV-0)**

SECTION: II

REV. 00

SECTION II



**1x800 MW TANGEDCO NORTH CHENNAI
TPP– (FGD SYSTEM)**

INSPECTION AND TESTING

**SPECIFICATION No: PE-TS-485- (571-13000-
A)-A001 (REV-0)**

SECTION : II

SUB-SECTION : 1

REV 00

SHEET 1 OF 4

SECTION-II

SUB-SECTION-1

INSPECTION AND TESTING

	<p align="center">1x800 MW TANGEDCO NORTH CHENNAI TPP– (FGD SYSTEM)</p> <p align="center">INSPECTION AND TESTING</p>	SPECIFICATION No: PE-TS-485- (571-13000-A)-A001 (REV-0)	
		SECTION : II	
		SUB-SECTION : 1	
		REV 00	
		SHEET 2 OF 4	
1.01.00	Inspection and Tests during Manufacture.		
1.01.01	The method and techniques to be used by the Bidder for the control of quality during manufacture of all plant and equipment shall be agreed with the Owner.		
1.01.02	The Owner’s general requirements with respect to quality control and the required shop tests are set out elsewhere in this specification.		
1.01.03	Before any item of plant or equipment leaves its place of manufacture the Owner shall be given the option of witnessing inspections and tests for compliance with the specification and related standards.		
1.01.04	Advance notice shall be given to the Owner as agreed in the Contract, prior to the stage of manufacture being reached, and the piece of plant must be held at this stage until the Owner has inspected the piece, or has advised in writing that inspection is waived. If having consulted the Owner and given reasonable notice in writing of the date on which the piece of plant will be available for inspection, the Owner does not attend the Bidder may proceed with manufacture having forwarded to the Owner duly certified copies of his own inspection and test results.		
	The owner’s representative shall have at all reasonable times access to bidder’s or his sub-vendor’s premises and shall have power to inspect/ examine materials and workmanship or equipment under manufacture.		
	The Bidder shall forthwith forward to the engineer duly certified copies of the Test Certificates in six copies (one to the Purchaser and five to the Consulting Engineer) for approval. Further nine (9) copies of Shop Test Certificates shall be bound with Instruction Manuals referred to elsewhere.		
	For electrical equipment, routine tests as per relevant IS spec are to be carried out on all equipment. Type tests are also to be carried out on selected equipment as detailed in the specs of concerned electrical equipment.		
1.01.05	Under no circumstances any repair or welding of castings be carried out without the consent of the Engineer. Proof of the effectiveness of each repair by radiographic and/or other non-destructive testing technique, shall be provided to the Engineer.		
1.01.06	All the individual and assembled rotating parts shall be statically and dynamically balanced in the works. Where accurate alignment is necessary for component parts of machinery normally assembled on site, the Bidder shall allow for trial assembly prior to despatch from place of manufacture.		
1.01.07	All materials used for the manufacture of equipment covered under this specification shall be of tested quality. Relevant test certificates shall be made available to the Purchaser. The certificates shall include tests for mechanical properties and chemical		



**1x800 MW TANGEDCO NORTH CHENNAI
TPP– (FGD SYSTEM)**

**SPECIFICATION No: PE-TS-485- (571-13000-
A)-A001 (REV-0)**

SECTION : II

SUB-SECTION : 1

REV 00

SHEET 3 OF 4

INSPECTION AND TESTING

analysis of representative material. Equipment or parts coming under any statutory Regulations shall be certified by a Competent Authority under the regulations in the specified format.

1.01.08 All pressure parts connected to pumping main shall be subjected to hydraulic testing at a pressure of 150% of shut-off head for a period not less than one hour. Other parts shall be tested for one and half times the maximum operating pressure, for a period not less than one hour.

1.01.09 All necessary non-destructive examinations shall be performed to meet the applicable code requirements.

1.01.10 All welding procedures adopted for performing welding work shall be qualified in accordance with the requirements of Section-IX of ASME code or IBR as applicable. All welded joints for pressure parts shall be tested by liquid penetrant examination according to the method outlined in ASME Boiler and Pressure Vessel code. Radiography, magnetic particle examination magnuflux and ultrasonic testing shall be employed wherever necessary/ recommended by the applicable code. At least 10% of all major but welding joints shall be radiographed unless otherwise stipulated.

Statutory payments in respect of IBR approvals including inspection shall be made by the bidder. Bidder's scope shall include to preparation of all necessary documents, co-ordination and follow-up for above approval. Owner shall only forward assistance/endorsement of documents /design /drawings /reports/records to be submitted for approval as stipulated/ required by Statutory Authorities till registration of the unit and clearance for commercial operation.

1.02.00 Performance Tests at Site

1.02.01 The full requirements for testing the system shall be agreed between the Owner and the Bidder prior to Award of Contract. The completely erected System shall be tested by the Bidder on site under normal operating conditions. The Bidder shall also ensure the correct performance of the System under abnormal conditions, i.e. the correct working of the various emergency and safety devices, interlocks, etc.

1.02.02 The Bidder shall provide complete details of his normal procedures for testing, for the quality of erection and for the performance of the erected plant. These tests shall include site pressure test on all erected pipe work to demonstrate the quality of the piping and the adequacy of joints made at site.

1.02.03 The Bidder shall furnish the quality procedures to be adopted for assuring quality from the receipt of material at site, during storage, erection, pre-commissioning to tests on completion and commissioning of the complete system/equipment.

1.03.00 For details of specific tests required on individual equipment refer to respective section of this specification.

	1x800 MW TANGEDCO NORTH CHENNAI TPP– (FGD SYSTEM) HVAC SYSTEM LIST OF DOCUMENTS TO BE SUBMITTED WITH BID	SPECIFICATION No: PE-TS-439- (571-13000-A)-A001 (REV-0)	
		SECTION : II	
		SUB-SECTION : 2	
		REV: 00	
		SHEET 1 OF 1	

BIDDER SHOULD SUBMIT THE SIGNED AND STAMPED COPY OF THE FOLLOWING DOCUMENTS:

1. Compliance cum confirmation certificate
2. Guaranteed power consumption (In the format attached in the spec mentioning KW rating).
3. Un priced format for Main package, Mandatory Spares, Tools and Tackles, Commissioning Spares (mentioning quoted/not quoted against each item)
4. Deviation schedule /No deviation certificate in attached format 'Deviation sheet (Cost of withdrawal)'.



**1x800 MW TANGEDCO NORTH CHENNAI
TPP– (FGD SYSTEM)
HVAC SYSTEM
COMPLIANCE CUM CONFIRMATION
CERTIFICATE**

**SPECIFICATION No: PE-TS-485- (571-13000-
A)-A001 (REV-0)**

SECTION : II

SUB-SECTION : 3

REV. NO. 00

SHEET: 1 OF 2

COMPLIANCE CUM CONFIRMATION CERTIFICATE

The bidder shall confirm compliance with following by signing / stamping this compliance certificate (every sheet) and furnish same with the offer.

- a) The scope of supply, technical details, construction features, design parameters etc. shall be as per technical specification & there are no exclusions, other than those mentioned under “exclusion and those resolved as per ‘Schedule of Deviations’, with regard to same.
- b) There are no other deviations w.r.t. specifications other than those furnished in the ‘Schedule of Deviations’. Any other deviation, stated or implied, taken elsewhere in the offer stands withdrawn unless specifically brought out in the ‘Schedule of Deviations’
- c) Bidder shall submit QP in the event of order based on the guidelines given in the specification & QP enclosed therein. QP will be subject to BHEL / CUSTOMER approval & customer hold points for inspection / testing shall be marked in the QP at the contract stage. Inspection / testing shall be witnessed as per same apart from review of various test certificates/ Inspection records etc. This is within the contracted price without any extra implications to BHEL after award of the contract.
- d) All drawings/ data-sheets / calculations etc. submitted along with the offer shall not be taken cognizance off.
- e) The offered materials shall be either equivalent or superior to those specified in the specification & shall meet the specified / intended duty requirements. In case the material specified in the specifications is not compatible for intended duty requirements then same shall be resolved by the bidder with BHEL during the pre-bid discussions, otherwise BHEL / Customer’s decision shall be binding on the bidder whenever the deficiency is pointed out.

For components where materials are not specified, same shall be suitable for intended duty, all materials shall be subject to approval in the event of order.

- f) The commissioning spares shall be supplied on ‘As Required Basis’ & prices for same included in the base price itself.
- g) All sub vendors shall be subject to BHEL / CUSTOMER approval in the event of order.
- h) Guarantee for plant/equipment shall be as per relevant clause of GCC / SCC / Other Commercial Terms & Conditions
- i) In the event of order, all the material required for completing the job at site shall be supplied by the bidder within the ordered price even if the same are additional to approved billing break up, approved drawing or approved Bill of quantities within the scope of work as tender specification. This clause will apply in case during site



**1x800 MW TANGEDCO NORTH CHENNAI
TPP– (FGD SYSTEM)
HVAC SYSTEM
COMPLIANCE CUM CONFIRMATION
CERTIFICATE**

SPECIFICATION No: PE-TS-485- (571-13000-A)-A001 (REV-0)

SECTION : II

SUB-SECTION : 3

REV. NO. 00

SHEET: 2 OF 2

commissioning, additional requirements emerges due to customer and / or consultant's comments. No extra claims shall be put on this account

- j) Schedule of drawings submissions, comment incorporations & approval shall be as stipulated in the specifications. The successful bidder shall depute his design personnel to BHEL's / Customer's / Consultant's office for across the table resolution of issues and to get documents approved in the stipulated time.
- k) As built drawings shall be submitted as and when required during the project execution.
- l) The bidder has not tempered with this compliance cum confirmation certificate and if at any stage any tempering in the signed copy of this document is noticed then same shall be treated as breach of contract and suitable actions shall be taken against the bidder.
- m) Successful bidder shall furnish detailed erection manual for each of the equipment supplied under this contract at least 3 months before the scheduled erection of the concerned equipment / component or along with supply of concerned equipment / component whichever is earlier.
- n) Document approval by customer under Approval category or information category shall not absolve the vendor of their contractual obligations of completing the work as per specification requirement. Any deviation from specified requirement shall be reported by the vendor in writing and require written approval. Unless any change in specified requirement has been brought out by the vendor during detail engineering in writing while submitting the document to customer for approval, approved document (with implicit deviation) will not be cited as a reason for not following the specification requirement.
- o) In case vendor submits revised drawing after approval of the corresponding drawing, any delay in approval of revised drawing shall be to vendor's account and shall not be used as a reason for extension in contract completion.



**1x800 MW TANGEDCO NORTH CHENNAI
 TPP– (FGD SYSTEM)
 HVAC SYSTEM
 PRE-BID CLARIFICATION SCHEDULE**

SPECIFICATION No: PE-TS-485- (571-13000-A)-A001 (REV-0)

SECTION : II

SUB-SECTION : 4

REV. NO. 00

SHEET: 1 OF 1

PRE-BID CLARIFICATION SCHEDULE

S. NO.	SECTION/CLAUSE/PAGE NO.	STATEMENT OF THE REFERRED CLAUSE	CLARIFICATION REQUIRED

The bidder hereby clarifies that above mentioned are the only clarifications required on the technical specification for the subject package.

Signature: _____

Name: _____

Designation: _____

Company: _____

Date: _____

Company Seal



**1x800 MW TANGEDCO NORTH CHENNAI
TPP– (FGD SYSTEM)
HVAC SYSTEM
NO DEVIATION CERTIFICATE**

SPECIFICATION No: PE-TS-485- (571-13000-A)-A001 (REV-0)

SECTION : II

SUB-SECTION : 5

REV: 00

DEVIATION SHEET (COST OF WITHDRAWAL)

		ANNEXURE-II: DEVIATION SHEET (COST OF WITHDRAWAL)							
		PROJECT:-		1x800 MW TANGEDCO NORTH CHENNAI TPP - (FGD SYSTEM)					
		PACKAGE:-		HVAC System					
TENDER ENQUIRY REFERENCE:-									
NAME OF VENDOR:-									
SL NO	VOLUME/SECTION	PAGE NO.	CLAUSE NO.	TECHNICAL SPECIFICATION/TENDER DOCUMENT	COMPLETE DESCRIPTION OF DEVIATION	COST OF WITHDRAWAL OF DEVIATION	REFERENCE OF PRICE SCHEDULE ON WHICH COST OF WITHDRAWAL OF DEVIATION IS APPLICABLE	NATURE OF COST OF WITHDRAWAL OF DEVIATION (POSITIVE/NEGATIVE)	REASON FOR QUOTING DEVIATION
TECHNICAL DEVIATIONS									
COMMERCIAL DEVIATIONS									
PARTICULARS OF BIDDERS' AUTHORISED REPRESENTATIVE									
NAME				DESIGNATIONS			SIGN & DATE		
NOTES:									
1. Cost of withdrawal of deviation will be applicable on the basic price (i.e. excluding taxes, duties & freight) only.									
2. All the bidders have to list out all their Technical & Commercial Deviations (if any) in detail in the above format.									
3. Any deviation not mentioned above and shown separately or found hidden in offer, will not be taken cognizance of.									
4. Bidder shall submit duly filled unpriced copy of above format indicating "quoted" in "cost of withdrawal of deviation" column of the schedule above along with their Techno-commercial offer, wherever applicable. In the absence of same, such deviation(s) shall not be considered and offer shall be considered in total compliance to NIT.									
5. Bidder shall furnish price copy of above format along with price bid.									
6. The final decision of acceptance/rejection of the deviations quoted by the bidder shall be at discretion of the Purchaser.									
7. Bidders to note that any deviation (technical/commercial) not listed in above and asked after Part-I opening shall not be considered.									
8. For deviations w.r.t. Credit Period, Liquidated damages, Firm prices if a bidder chooses not to give any cost of withdrawal of deviation loading as per Annexure-VII, will apply. For any other deviation mentioned in un-priced copy of this format submitted with Part-I bid but not mentioned in priced copy of this format submitted with Priced bid, the cost of withdrawal of deviation shall be taken as NIL.									
9. Any deviation mentioned in priced copy of this format, but not mentioned in the un-priced copy, shall not be considered.									
10. All techno-commercial terms and conditions of NIT shall be deemed to have been accepted by the bidder, other than those listed in unpriced copy of this format.									
11. Cost of withdrawal is to be given separately for each deviation. In no event bidder should club cost of withdrawal of more than one deviation else cost of withdrawal of such deviations which have been clubbed together shall be considered as NIL.									
12. In case nature of cost of withdrawal (positive/negative) is not specified it shall be assumed as positive.									
13. In case of discrepancy in the nature of impact (positive/negative), positive will be considered for evaluation and negative for ordering.									



**1x800 MW TANGEDCO NORTH CHENNAI
TPP– (FGD SYSTEM
HVAC SYSTEM
NO DEVIATION CERTIFICATE**

**SPECIFICATION No: PE-TS-485- (571-13000-
A)-A001 (REV-0)**

SECTION : II

SUB-SECTION : 6

REV: 00

SHEET 1 OF 1

SECTION-II

SUB-SECTION-5

GUARANTEE POWER CONSUMPTION

**1x800 MW TANGEDCO NORTH CHENNAI TPP– (FGD SYSTEM)
HVAC SYSTEM**

GUARANTEED POWER CONSUMPTION

SL NO	DESCRIPTION	Capacity	QUANTITY (WORKING)		POWER CONSUMPTION AS GUARANTEED (KW) AT MOTOR INPUT TERMINAL	DUTY FACTOR	TOTAL POWER CONSUMPTION AS GUARANTEED (KW)
			(WORKING)	(STANDBY)			
(1)	(2)		(3A)	(3B)	(4)	(5)	(6)=(3A)x(4)X(5)
A	Air Conditioning System						
1	Air Cooled Conditioning Units (DX Type)	60 TR	1	1		1	
2	AHUs		1	1		1	
3	Fresh air fan for AHU Room		1	0		1	
4	Split AC (Cassette Type)	4 TR	6	6		1	
5	Hi wall Split AC	2 TR	4	4		1	
6	Hi wall Split AC	1.5 TR	12	12		1	
B	Ventilation System for						
1	UAF Unit	90000 CMH 65mm Static	1	0		1	
2	UAF Pump		1	1		1	
3	Axial flow exhaust fans (Bifurcated type)	10000 CMH, 15mm Static	2			1	
4	Axial Flow Supply Fans	10000 CMH 20 Static	61			1	
5	Axial flow exhaust fans	15000 CMH, 10mm Static	12			1	
6	Axial flow exhaust fans	10000 CMH, 10mm Static	8			1	
7	Axial flow exhaust fans	7500 CMH, 10mm Static	9			1	
8	Axial flow exhaust fans	6000 CMH 10mm Static	10			1	
9	Axial flow exhaust fans	4000 CMH 10mm Static	1			1	
10	Axial flow exhaust fans	2000 CMH 10mm Static	2			1	
					TOTAL CONSUMPTION (KW)		
	Estimated power consumption (EPC) figure for the system (for working drives only) has been considered as 342 KW . So long bidder's quoted guaranteed power consumption (GPC) above remains within this EPC, there will be no technical loading of bid on power consumption for evaluation. However, if bidder's quoted GPC exceeds EPC, there shall be technical loading of bid for evaluation @ Rs. 2,35,361/- per KW of additional power over EPC.						

Bidder's guaranteed power consumption at motor input terminals (not shaft power) as furnished in relevant schedule shall be demonstrated by the successful bidder during performance testing at works/ site. In case power consumption is noted higher than EPC / bidder's quoted GPC whichever is higher, during inspection/ PG test, penalty @ Rs. **2,35,361/-** per KW shall be levied on vendor.

In case of change in building size during detail engg leading to increase/decrease in no. of equipment, GPC of HVAC system for such building shall be adjusted suitably based on GPC value deduced from figure quoted by the bidder in this format

LEGEND	
GATE VALVE	
GATE VALVE (NORMALLY CLOSED)	
CHECK VALVE	
POT-STRAINER	
GLOBE VALVE	
DRAIN	
PRESSURE INDICATOR	
TEMPERATURE INDICATOR	
LEVEL TRANSMITTER	
SUCTION SCREEN	
REDUCER/ EXPANDER	
DIFFERENTIAL PRESSURE SWITCH	
PRESSURE TRANSMITTER	

NOTE:- One Humidistat shall be envisaged in MCC Area to interlock with pumps.

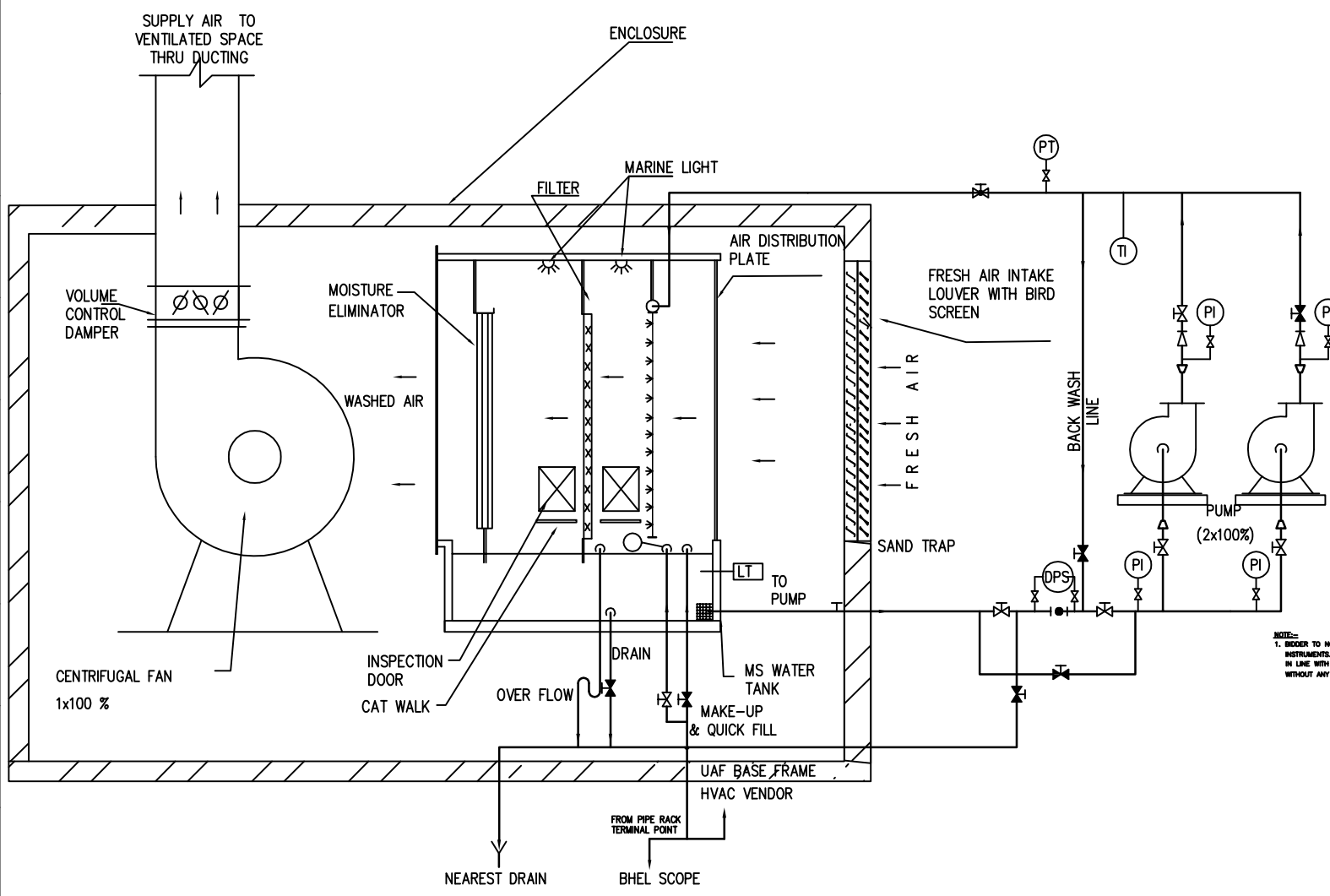

NOTE:-
1. BIDDER TO NOTE THAT THE P&ID SHOWS ONLY THE BARE MINIMUM REQUIREMENT OF VALVES AND INSTRUMENTS. ANY INSTRUMENTATION & VALVES AS REQUIRED FOR THE COMPLETION OF THE SYSTEM IN LINE WITH TECHNICAL SPECIFICATION SHALL BE PROVIDED BY BIDDER DURING DETAILED ENGINEERING WITHOUT ANY COMMERCIAL IMPLICATION.

CONTROLLER:	TANGEDCO
PROJECT:	13000MW NORTH CHERNAVI STAGESH - PGD
DESIGNER:	BEARAT HEAVY ELECTRICALS LTD POWER SECTOR PROJECT ENGINEERING MANAGEMENT NOKIA
DATE:	01/08/2011
SCALE:	AS SHOWN
TITLE:	P&ID FOR UAF (MODULAR TYPE)
DRAWING NO.:	360

COPYRIGHT RESERVED BY BEARAT HEAVY ELECTRICALS LTD. THE INFORMATION CONTAINED HEREIN IS UNCLASSIFIED AND NOT FOR DISTRIBUTION OUTSIDE THE ORGANIZATION.

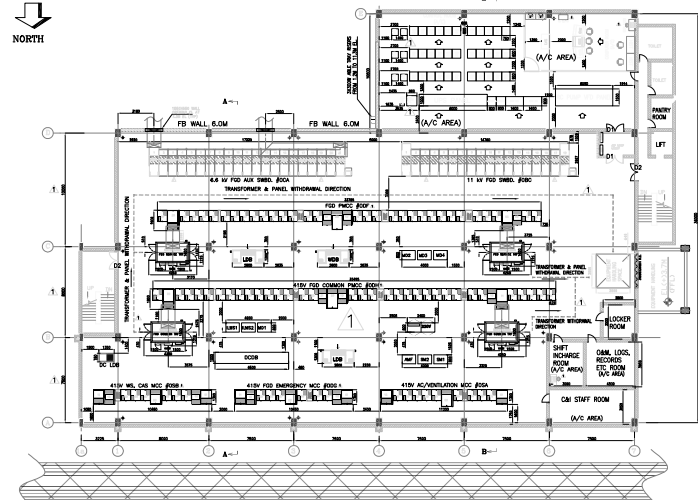

PLAN AT EL. 3.7M

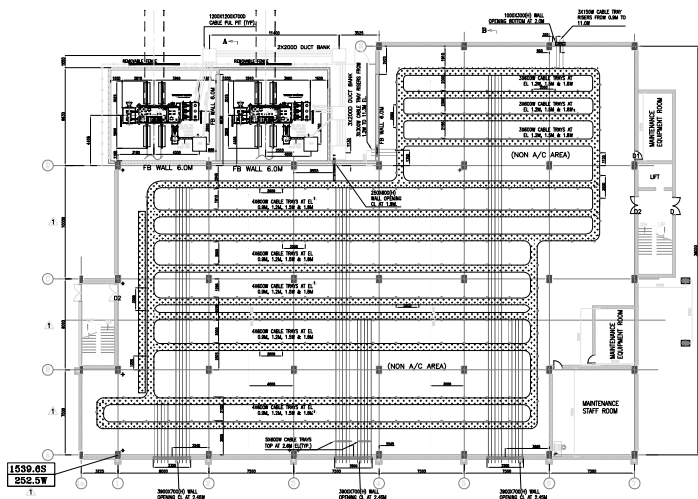

PLAN AT EL. 0.0M

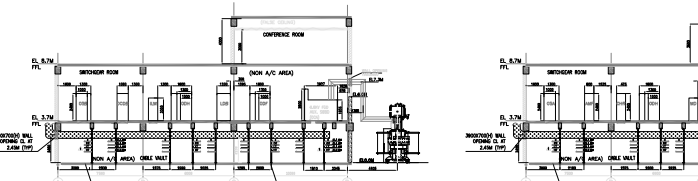

SECTION A-A

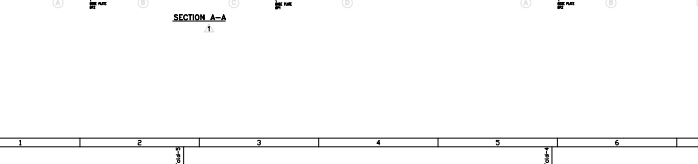

SECTION B-B

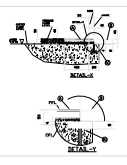
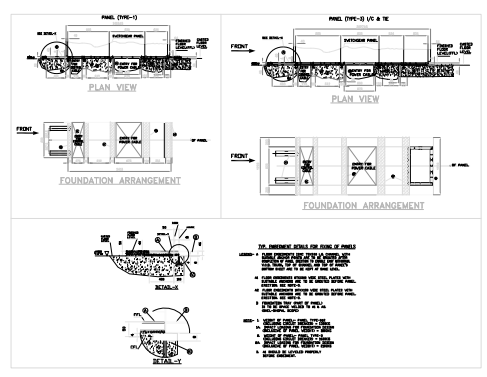

1. TO BE CONCRETE GRADE FOR FOUNDATION DETAIL
 2. TO BE CONCRETE GRADE FOR FOUNDATION DETAIL
 3. TO BE CONCRETE GRADE FOR FOUNDATION DETAIL
 4. TO BE CONCRETE GRADE FOR FOUNDATION DETAIL
 5. TO BE CONCRETE GRADE FOR FOUNDATION DETAIL
 6. TO BE CONCRETE GRADE FOR FOUNDATION DETAIL
 7. TO BE CONCRETE GRADE FOR FOUNDATION DETAIL
 8. TO BE CONCRETE GRADE FOR FOUNDATION DETAIL
 9. TO BE CONCRETE GRADE FOR FOUNDATION DETAIL
 10. TO BE CONCRETE GRADE FOR FOUNDATION DETAIL
 11. TO BE CONCRETE GRADE FOR FOUNDATION DETAIL
 12. TO BE CONCRETE GRADE FOR FOUNDATION DETAIL
 13. TO BE CONCRETE GRADE FOR FOUNDATION DETAIL
 14. TO BE CONCRETE GRADE FOR FOUNDATION DETAIL
 15. TO BE CONCRETE GRADE FOR FOUNDATION DETAIL
 16. TO BE CONCRETE GRADE FOR FOUNDATION DETAIL
 17. TO BE CONCRETE GRADE FOR FOUNDATION DETAIL
 18. TO BE CONCRETE GRADE FOR FOUNDATION DETAIL
 19. TO BE CONCRETE GRADE FOR FOUNDATION DETAIL
 20. TO BE CONCRETE GRADE FOR FOUNDATION DETAIL

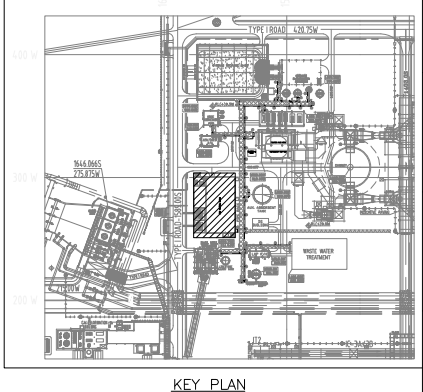
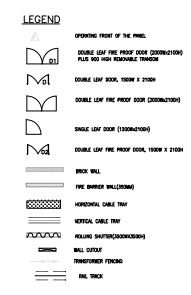

KEY PLAN

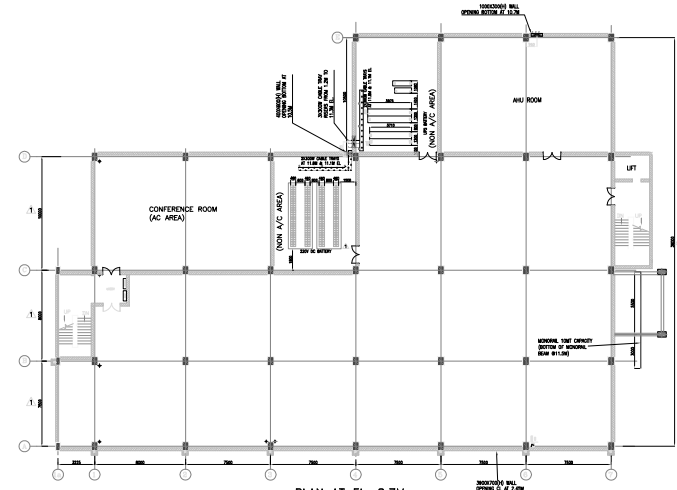

PLAN AT EL. 8.7M

REFERENCE SYMBOLS:

SYMBOL	ITEM	REFERENCE NO.	SOURCE REFERENCE
1.	ROOF PLAN - FOR AREA	PC-08-08-100-001	REL/ PWB-04
2.	ELECTRICAL SYMBOLS AND NOTATION	PC-08-08-100-001	REL/ PWB-04
3.	CABLE TRAY PROFILES	PC-08-08-100-004	REL/ PWB-04
4.	TYPICAL DETAILS OF CABLE TRAYS AND ACCESSORIES	PC-08-08-001-000	REL/ PWB-04
5.	INSTALLATION DETAILS OF CABLE TRAYS SUPPORT SYSTEM	PC-08-08-001-000	REL/ PWB-04
6.	GENERAL PROVISIONS FOR ELECTRICAL EQUIPMENT LAYOUT	PC-08-08-100-001	REL/ PWB-04
7.	IS 8000, 114/15/04 OF THE TRANSFORMER	PC-08-08-100-001	REL/ PWB-04
8.	IS 8000, 114/15/04 OF THE TRANSFORMER	PC-08-08-100-001	REL/ PWB-04
9.	IS 8000, 114/15/04 OF THE TRANSFORMER	PC-08-08-100-001	REL/ PWB-04
10.	IS 8000, 114/15/04 OF THE TRANSFORMER	PC-08-08-100-001	REL/ PWB-04
11.	IS 8000, 114/15/04 OF THE TRANSFORMER	PC-08-08-100-001	REL/ PWB-04
12.	IS 8000, 114/15/04 OF THE TRANSFORMER	PC-08-08-100-001	REL/ PWB-04
13.	IS 8000, 114/15/04 OF THE TRANSFORMER	PC-08-08-100-001	REL/ PWB-04
14.	IS 8000, 114/15/04 OF THE TRANSFORMER	PC-08-08-100-001	REL/ PWB-04
15.	IS 8000, 114/15/04 OF THE TRANSFORMER	PC-08-08-100-001	REL/ PWB-04
16.	IS 8000, 114/15/04 OF THE TRANSFORMER	PC-08-08-100-001	REL/ PWB-04
17.	IS 8000, 114/15/04 OF THE TRANSFORMER	PC-08-08-100-001	REL/ PWB-04
18.	IS 8000, 114/15/04 OF THE TRANSFORMER	PC-08-08-100-001	REL/ PWB-04
19.	IS 8000, 114/15/04 OF THE TRANSFORMER	PC-08-08-100-001	REL/ PWB-04
20.	IS 8000, 114/15/04 OF THE TRANSFORMER	PC-08-08-100-001	REL/ PWB-04

- NOTES:**
1. ALL DIMENSIONS ARE IN MM UNLESS SPECIFIED OTHERWISE.
 2. ALL DIMENSIONS SHOWN ARE TO FACE UNLESS SPECIFIED OTHERWISE.
 3. FOR FINISHES & MATERIALS REFER TO THE ARCHITECTURAL DRAWINGS.
 4. DIMENSIONS INDICATED FOR EQUIPMENT ARE PROVISIONAL. FINAL DIMENSIONS SHALL BE PROVIDED BY THE EQUIPMENT MANUFACTURER.
 5. THE SYSTEM IS TO BE INSTALLED IN ACCORDANCE WITH THE IS 8000, 114/15/04 OF THE TRANSFORMER.
 6. ALL WORK SHALL BE IN ACCORDANCE WITH THE IS 8000, 114/15/04 OF THE TRANSFORMER.
 7. CABLE TRAY SHALL BE PERFORMED IN ACCORDANCE WITH THE IS 8000, 114/15/04 OF THE TRANSFORMER.
 8. CABLE TRAY SUPPORTS SHALL BE PERFORMED IN ACCORDANCE WITH THE IS 8000, 114/15/04 OF THE TRANSFORMER.
 9. CABLE TRAY SUPPORTS SHALL BE PERFORMED IN ACCORDANCE WITH THE IS 8000, 114/15/04 OF THE TRANSFORMER.
 10. CABLE TRAY SUPPORTS SHALL BE PERFORMED IN ACCORDANCE WITH THE IS 8000, 114/15/04 OF THE TRANSFORMER.
 11. CABLE TRAY SUPPORTS SHALL BE PERFORMED IN ACCORDANCE WITH THE IS 8000, 114/15/04 OF THE TRANSFORMER.
 12. CABLE TRAY SUPPORTS SHALL BE PERFORMED IN ACCORDANCE WITH THE IS 8000, 114/15/04 OF THE TRANSFORMER.
 13. CABLE TRAY SUPPORTS SHALL BE PERFORMED IN ACCORDANCE WITH THE IS 8000, 114/15/04 OF THE TRANSFORMER.
 14. CABLE TRAY SUPPORTS SHALL BE PERFORMED IN ACCORDANCE WITH THE IS 8000, 114/15/04 OF THE TRANSFORMER.
 15. CABLE TRAY SUPPORTS SHALL BE PERFORMED IN ACCORDANCE WITH THE IS 8000, 114/15/04 OF THE TRANSFORMER.
 16. CABLE TRAY SUPPORTS SHALL BE PERFORMED IN ACCORDANCE WITH THE IS 8000, 114/15/04 OF THE TRANSFORMER.
 17. CABLE TRAY SUPPORTS SHALL BE PERFORMED IN ACCORDANCE WITH THE IS 8000, 114/15/04 OF THE TRANSFORMER.
 18. CABLE TRAY SUPPORTS SHALL BE PERFORMED IN ACCORDANCE WITH THE IS 8000, 114/15/04 OF THE TRANSFORMER.
 19. CABLE TRAY SUPPORTS SHALL BE PERFORMED IN ACCORDANCE WITH THE IS 8000, 114/15/04 OF THE TRANSFORMER.
 20. CABLE TRAY SUPPORTS SHALL BE PERFORMED IN ACCORDANCE WITH THE IS 8000, 114/15/04 OF THE TRANSFORMER.

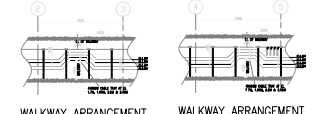

BILL OF QUANTITY FOR TRAYS, TRAY SUPPORT & ACCESS

S.NO.	MATERIAL DESCRIPTION	UNIT	QUANTITY
01	CABLE TRAY 600MM WIDE (LADDER TYPE)	METRES	2095
02	CABLE TRAY 600MM WIDE (PERFORATED TYPE)	METRES	925
03	CABLE TRAY 300MM WIDE (LADDER TYPE)	METRES	50
04	CABLE TRAY 100MM WIDE (LADDER TYPE)	METRES	50
05	SINGLE CHANNEL (SC1)	METRES	500
06	DOUBLE CHANNEL (DC1)	METRES	120
07	CANTILEVER ARM (600MM WIDE) FOR 600MM WIDE CABLE TRAYS (CA1)	NOS.	1500
08	CANTILEVER ARM (300MM WIDE) FOR 300MM WIDE CABLE TRAYS (CA2)	NOS.	25
09	BASE PLATE FOR DOUBLE CHANNEL (BP2)	NOS.	45
10	90° HORIZONTAL BEND FOR ROW TRAY (LADDER TYPE)	NOS.	28
11	90° HORIZONTAL BEND FOR ROW TRAY (PERFORATED TYPE)	NOS.	12
12	TEE FOR ROW TRAY (LADDER TYPE)	NOS.	60
13	TEE FOR ROW TRAY (PERFORATED TYPE)	NOS.	28
14	CLAMP FOR SINGLE CHANNEL (CC1)	NOS.	220
15	ANGLE FITTING (A1)	NOS.	290
16	ANGLE FITTING (A2)	NOS.	240
17	BASE PLATE FOR SINGLE CHANNEL (BP1)	NOS.	180

CUSTOMER: TAMILNADU GENERATION & DISTRIBUTION CORPORATION LIMITED
 8th Floor, Western Wing, NPKRR Main Gate,
 144, Anna Salai, Chennai-600002

SUBMITTANT: Fichtner Consulting Engineers (India) Pvt Ltd.
 Menon Srinivasan, 8th Floor, No.165, St. Mary's Road,
 Alwarpet, Chennai-600018

PROJECT: 13800 MW TANGEDCO NORTH CHENNAI TYP
 STAGE III-BTG

CLIENT: BHARAT HEAVY ELECTRICALS LTD
 POWER SECTOR
 PROJECT ENGINEERING MANAGEMENT
 DISTRIBUTION
 INDIA

JOB NO.: A85
STATUS: CONTRACT
REVISION: 01

DATE: 15/08/2018
BY: [Signature]
CHECKED: [Signature]
APPROVED: [Signature]

TITLE: ELECTRICAL EQUIPMENT & CABLING LAYOUT IN
 FGD CONTROL ROOM BUILDING

SCALE: 1:1
DRAWING NO.: PE-100-485-100-0008
SHEET: 1 OF 1
REV.: 1