

TELANGANA STATE POWER GENERATION CO. LTD.

4 X 270 MW BHADRADRI TPS – FGD SYSTEM

VOLUME – II

**TECHNICAL SPECIFICATION FOR
LIGHTING FIXTURES, LAMPS AND MISCELLANEOUS ITEMS**

SPECIFICATION NO : PE-TS-440-558-E006, REV 02



**BHARAT HEAVY ELECTRICALS LIMITED
POWER SECTOR
PROJECT ENGINEERING MANAGEMENT
NOIDA, UTTAR PRADESH, INDIA – 201301**

884639/2022/PS-PEM-EL



TECHNICAL SPECIFICATION FOR STATION LIGHTING SYSTEM	SPECIFICATION NO. PE-TS-440-558-E006	
	VOLUME II	
4 X 270 MW TSGENCO BHADRADRI TPS - FGD SYSTEM	REV. 02	DATE: 02.05.2022
	SHEET 1 OF 1	

CONTENTS

<u>S NO.</u>	<u>DESCRIPTION</u>	<u>NO. OF SHEETS</u>
01	SECTION - I	
	COVER SHEET	1
	CONTENT	1
	COMPLIANCE CERTIFICATE	1
	SPECIFIC TECHNICAL REQUIREMENT	18
	DATA SHEET-A	7
	DATA SHEET-B	1
	ANNEXURE-E PACKING SPECIFICATION	1
	ANNEXURE-F	1
02	SECTION - II	
	COVER SHEET	1
	STANDARD SPECIFICATION	38
	STANDARD QUALITY PLAN	10
	ANNEXURE-1 TO AMENDMENT TYPICAL ARRANGEMENT	10
TOTAL NUMBER OF SHEETS (INCLUDING COVER & SEPARATOR SHEETS) : 90		

884639/2022/PS-PEM-EL



**TECHNICAL SPECIFICATION FOR
LIGHTING FIXTURES, LAMPS AND
MISCELLANEOUS ITEMS**

SPECIFICATION NO. PE-TS-440-558-E006

VOLUME II

SECTION - I

**4 X 270 MW TSGENCO BHADRADRI TPS -
FGD SYSTEM**

REV. 02

DATE: 02.05.2022

SHEET 1 OF 1

COMPLIANCE CERTIFICATE

The bidder shall confirm compliance to the following by signing/ stamping this compliance certificate and furnishing same with the offer.

1. The scope of supply, technical details, construction features, design parameters etc. shall be as per technical specification & there are no exclusion/ deviation with regard to same.
2. There is no deviation with respect to specification other than those furnished in the 'schedule of deviations'.
3. Only those technical submittals which are specifically asked for in NIT to be submitted at tender stage shall be considered as part of offer. Any other submission, even if made, shall not be considered as part of offer.
4. Any comments/ clarifications on technical/ inspection requirements furnished as part of bidder's covering letter shall not be considered by BHEL, and bidder's offer shall be construed to be in conformance with the specification.
5. Any changes made by the bidder in the price schedule with respect to the description/ quantities from those given in BOQ-Cum-Price schedule of the specification shall not be considered (i.e. technical description & quantities as per specification shall prevail).

BIDDER'S STAMP & SIGNATURE

884639/2022/PS-PEM-EL



**TECHNICAL SPECIFICATION FOR
LIGHTING FIXTURES, LAMPS AND
MISCELLANEOUS ITEMS**

SPECIFICATION NO. PE-TS-440-558-E006

VOLUME II

SECTION – I

**4X270 MW TSGENCO BHADRADRI TPS -
FGD SYSTEM**

REV. 02

DATE: 02.05.2022

SHEET 1 OF 18

SECTION – I

SPECIFIC TECHNICAL REQUIREMENTS



**TECHNICAL SPECIFICATION FOR
LIGHTING FIXTURES, LAMPS AND
MISCELLANEOUS ITEMS**

**4X270 MW TSGENCO BHADRADRI TPS -
FGD SYSTEM**

SPECIFICATION NO. PE-TS-440-558-E006

VOLUME II

SECTION – I

REV. 02

DATE: 02.05.2022

SHEET 2 OF 18

1.0 SCOPE OF SUPPLY AND SERVICES

- 1.1 **SUPPLY:** Design, manufacture, assembly, inspection & testing at vendor's/ sub-vendor's works, proper packing and delivery to site of LIGHTING FIXTURES, LAMPS & MISCELLANEOUS ITEMS as mentioned in different sections of this specification, complete with all accessories for efficient and trouble-free operation.
- 1.2 **SYSTEM ENGINEERING:** System Engineering is included in vendor's scope, which includes design of complete lighting system for indoor and outdoor areas. Tentative areas as mentioned in Annexure-A to be covered by lighting system & other drawings to be submitted by vendor. The aspect of engineering covers preparation of electrical distribution and control schemes, quantity estimation, luminaire layout drawings, conduit layout drawings, wiring schemes up to luminaires, cable schedules and all associated design work not specifically mentioned in the specification. The quantity estimation to include all items required for the complete lighting system viz. lighting fixtures, Lighting DBs, Welding DBs, LPs, Conduits, Wires & other misc. items including consumables & erection hardwares.
- 1.3 Supervision of Erection & Commissioning (as required by site) of lighting system is included in vendor's scope.
- 1.4 Although Erection and Commissioning is not included in vendor's scope, the vendor shall still not be absolved of his responsibility of establishing the correctness of engineering and equipment at site.
- 1.5 Standard technical requirements of the lighting fixtures, lamps & miscellaneous items and lighting system design requirements are indicated in Section-II. Project specific requirements/changes are listed in Section-I.
- 1.6 The stipulations of Section-I, followed by those of Data Sheet-A shall prevail and govern in case of conflict between the corresponding requirements of Section-I and Section-II.
- 1.7 Review of sub-vendor's documents by the vendor shall not relieve the vendor from the responsibility of design & supply.
- 1.8 The documents shall be in English language and MKS system of units.
- 1.9 Make of all equipment and components shall be as per attached Sub-Vendor List enclosed as per Annexure-C to section- I.

2.0 BILL OF QUANTITIES:

- 2.1 Quantity requirements shall be as per BOQ-cum-price schedule as part of NIT.

3.0 BILL OF QUANTITIES:

- 3.1 Statutory and regulatory regulation shall be applicable as per Indian Electricity Rule, 1956 with amendment-3 Rule no. 35, 48, 49, 50, 61 & 64 for illumination & low voltage power services.

	TECHNICAL SPECIFICATION FOR LIGHTING FIXTURES, LAMPS AND MISCELLANEOUS ITEMS	SPECIFICATION NO. PE-TS-440-558-E006	
		VOLUME II	
	4X270 MW TSGENCO BHADRADRI TPS - FGD SYSTEM	REV. 02	DATE: 02.05.2022
		SHEET 3 OF 18	

4.0 DOCUMENTATION

4.1 Documents required along with the technical offer: -

- Signed & Stamped copy of Compliance certificate.
- Dully filled in signed & stamped copy of scope matrix for board activities (Annexure-F of Section-I).
- Signed & stamped copy of unpriced price schedule with “quoted” word indicated against all items.
- Duly filled in signed & stamped copy of Datasheet-B.

4.2 Documents required after award of LOI/PO shall be as per NIT (to be submitted by successful bidder).

5.0 SPECIFIC TECHNICAL REQUIREMENTS

Sl. No.	Reference Clause No. of Section- II	Specific Requirement/ Change
1.0	5.2.1(n), 15 : Page-17 of 38	Following protection to be added under clause 15: <ul style="list-style-type: none"> Surge Protection
2.0	Additional requirement in Clause no. 12.4, Page 20 of 38	Junction boxes shall be of 16 SWG sheet steel hot-dip galvanised, dust and damp proof, generally conforming to IP-55. Junction boxes shall be complete with gasketed inspection cover, conduit knock out/threaded hub and terminal blocks. Junction boxes for outdoor use shall be weatherproof IPW-55 and those for hazardous location shall be flame-proof type. Junction boxes shall have following indelible markings: Circuit nos. on top Circuit nos. with ferrules (inside) as per drawing DANGER sign in case of 415V circuit
3.0	Clause no. 5.12 g), Page 22-23 of 38 I) i II) i III) i & iv	Referred clause shall be read as: I) i: RA: 20A, 240V, 2 pole, 3 pin with third pin earthed, wall/ column mounted, metal clad gasketed construction, 20mm conduit entry, screwed metal cover tied to it by a metal chain, weatherproof suitable for indoor/outdoor installation. II) i: RB: 5A & 15A to be replaced with 6A & 16A respectively in standard specification. III) i & iv: RC: 63A, 415 V, 3 phase, 4 pin interlocked plug and switch with earthing contact, wall/column mounted, metal clad gasketed construction, weatherproof, suitable for entry and exit of upto 3.5C-95 Sq.mm XLPE cable and loop-in loop-out terminals for the same shall be provided such that not more than one core is terminated at one terminal. Removable, undrilled cable gland plate shall be provided. Tinned copper lugs and double compression cable glands shall also be supplied by the bidder.
4.0	5.14(a) : Page-24 of 38	Referred clause shall be read as: All switch boards/boxes shall be of bent steel construction, fabricated of 14 SWG M.S. sheet with 6 mm thick bakelite cover with brass fixing screws.
5.0	5.14(f) : Page-25 of 38	Referred clause shall be read as: The size of switch-boxes shall be adequately chosen to accommodate the no. of switches and fan regulator boxes specified below. Fan regulators shall be supplied separately. Flush type

	TECHNICAL SPECIFICATION FOR LIGHTING FIXTURES, LAMPS AND MISCELLANEOUS ITEMS	SPECIFICATION NO. PE-TS-440-558-E006		
		VOLUME II		
	4X270 MW TSGENCO BHADRADRI TPS - FGD SYSTEM	REV. 02	DATE: 02.05.2022	
		SHEET 4 OF 18		

		<p>receptacles where provided shall be so located that only the plug projects outside.</p> <ol style="list-style-type: none"> Type SWB1 - Switch board with 1 no. 6A switch, JB type SW1. Type SWB2 - 3 nos. 6A switches and 1 no. 6A Socket, JB type SW2. Type SWB2a - 3 nos. 6A switches and 2 no. fan regulator, JB type SW2. Type SWB3 - 6 nos. 6A switches and 1 no. 6A Socket, JB type SW3. Type SWB3a - 5 nos. 6A switches and 2 no. fan regulator, JB type SW3. <p>JB details for lighting control switch boxes are as below: JB-SW1 Provided with four (4) way stud type terminals, each terminal suitable for terminating upto two nos. of 10 mm² stranded aluminium/copper conductor. JB-SW2 Similar to the JB-SW1 but provided with ten (10) way terminals. JB-SW3 Similar to the JB-SW1 but provided with eighteen (18) way terminals.</p>
6.0	Add new clause 7.2.1 after clause 7.2 in Section-II : Page 27 of 38	<p>New Clause 7.2.1: Materials like Concrete Blocks of Paved surface required for installation and placing of container shall be made available by BHEL. Other supporting material like Rails etc. shall be part of Container only. Packing factor & container type/material shall be decided by vendor based on industrial practice and to meet requirement of clause 7.2.</p>
7.0	Clause 12.4, Page 30 of 38	<p>Referred clause shall be read as: Preparation of as-built drawings shall be in BHEL Scope. However, vendor shall be furnishing the Final Auto Cad drawings to BHEL.</p>
8.0	Additional clause	<p>Portable Emergency Lighting Unit The portable emergency lighting unit shall be complete with 6 volt storage battery (rechargeable), inverter, automatic charger, twin 6 watts LED lamp and test switch. Vendor shall furnish make, type and catalogue out sub vendor list.</p>
9.0	Additional clause	<p>24 V Supply Module Each 24V A.C. supply module shall have one (1) no dry type two winding transformer and necessary terminals for incoming and outgoing connections. The 240V terminals of 24V AC supply module shall be fed from AC emergency lighting panels (ACELP). Details of 24V A.C. supply modules shall be as given below: Module type: Portable type/ Fixed type with receptacle distribution panel Transformer rating: 500 VA Transformer voltage ratio: 240/26.5 Volt Primary side isolation: DP MCB with HRC fuse Isolation rating: 16A HRC fuse rating: 6A</p>

884639/2022/PS-PEM-EL



**TECHNICAL SPECIFICATION FOR
LIGHTING FIXTURES, LAMPS AND
MISCELLANEOUS ITEMS**

**4X270 MW TSGENCO BHADRADRI TPS -
FGD SYSTEM**

SPECIFICATION NO. PE-TS-440-558-E006

VOLUME II

SECTION – I

REV. 02

DATE: 02.05.2022

SHEET 5 OF 18

		Secondary side isolation: SPN MCB with HRC fuse Isolation rating: 6A HRC fuse rating: 16A
10.0	Additional clause	Although supply of lighting erection hardware & consumable are not in contractor's scope (refer BOQ for list & quantity). However, contractor shall furnish list of all erection materials, hardware and consumables required for the complete installation. The list materials shall include but shall not be limited to the following: a) Hardware: Bolts, nuts, washers, screws, brackets, supports, clamps, hangers, saddles, cleats, sills, shims etc. b) Materials: Junction boxes, terminal blocks, connectors, ferrules, lugs, brass glands, rigid/flexible conduits, cables, ground wires etc.
11.0	Additional clause	1. Voltage drop at the fixture from the MLDB bus will not exceed 3%. 2. Sub circuit loading of each lighting panel will be restricted to 2000 Watts. 3. Circuit loading of each lighting Panel will be done in such a way that almost balanced loading in all the phases is achieved.
12.0	Additional clause	Suitable numbers of 24V portable halogen lamp unit along with flexible copper cable shall be supplied as per details below: Lamp wattage: 40 W Cable size: 2.5 sq. mm Stranded copper Cable length: 20 meter
13.0	Additional clause	Free standing shall be aluminium ladder, adjustable from 5M to 10M.
14.0	Additional clause	Following items are excluded from the supply of this package: Poles, Mast, LDB, WDB, Lighting panels, Rigid conduit, and PVC Wires.
15.0	Additional clause	Pedestal Fan will have 400mm Sweep (50-65 Wattage).
16.0	Additional clause	Packing specification as per Annexure-E to be followed by vendor.
17.0	Additional clause	Lighting system will be designed to ensure adequate uniform visual performance, safety & reliability and will be free from excessive glare and flicker from discharge lamp. In main control room, particular attention will be given to ensure that illumination is proper and aesthetic. Control room lighting will be such as to prevent any glare/ luminous patch on control board /panel/ VDUs when viewed from an angle. Customer approved Design memorandum of Illumination System shall be provided to successful vendor.
18.0	Additional clause	Additional Clause No. 6 to be added under Annexure-I of section-II as below.
19.0	Additional clause	All high bay fixtures will have vibration damper.

	TECHNICAL SPECIFICATION FOR LIGHTING FIXTURES, LAMPS AND MISCELLANEOUS ITEMS		SPECIFICATION NO. PE-TS-440-558-E006	
			VOLUME II	
			SECTION – I	
	4X270 MW TSGENCO BHADRADRI TPS - FGD SYSTEM		REV. 02	DATE: 02.05.2022
		SHEET 6 OF 18		

6.0 SPECIFIC TECHNICAL REQUIREMENTS

S. No.	Type of Luminaire	Description	Total Luminous Flux (Lumen) of Luminaire – Min. Value	Measured Electrical Input Power (Watt) of Luminaire – Max. Value
01	FC06 (LED)	Industrial type LED fixture suitable for conduit/ surface/ suspended mounting with integral driver aesthetically designed for Switchgear/ Equipment room/ stair case/ corridors.	3780	42
02	FC07 (LED)	Industrial type LED fixture suitable for conduit/ surface/ suspended/ column mounting with integral driver. Fixture shall operate at 220 V DC supply. Necessary accessories like DC to AC convertor etc. to be included in fixture, if required.	1260	14
03	FC26 (LED)	Panel (approx. 1200mm x300mm) decorative LED fixture suitable for recess mounting in false ceiling with integral driver aesthetically designed for Control Room/ Office.	3780	42
04	FC30 (LED)	Panel 600mm x600mm decorative LED fixture suitable for recess mounting in false ceiling with integral driver aesthetically designed for Control Room/ Office.	3780	42
05	FC32 (LED)	Decorative, surface mounted LED fixture having integral driver	3780	42
06	FC33 (LED)	Decorative, recessed type LED fixture (down lighter) with integral driver. Fixture shall operate at 220 V DC supply. Necessary accessories like DC to AC convertor etc. to be included in fixture, if required.	1260	14
07	FC34 (LED)	Well glass, dust proof type LED fixture having integral driver. Fixture shall operate on 220V DC input supply. Necessary accessories like DC to AC convertor etc. to be included accordingly, if required.	1260	14
08	FC81 (LED)	Corrosion proof, totally enclosed type LED fixture with integral driver.	3780	42
09	SF63 (LED)	Flood light, Heavy duty type LED fixture with integral driver.	16920	188
10	SF64 (LED)	Flood light, Heavy duty type LED fixture with integral driver.	27000	300
11	SF66 (LED)	Flood light, Heavy duty type LED fixture with integral driver.	45000	500
12	SB11 (LED)	Medium Bay, Industrial type LED fixture with integral driver.	10080	112
13	SB02 (LED)	High Bay, Industrial type LED fixture with integral driver.	16920	188

	TECHNICAL SPECIFICATION FOR LIGHTING FIXTURES, LAMPS AND MISCELLANEOUS ITEMS	SPECIFICATION NO. PE-TS-440-558-E006	
		VOLUME II	
	4X270 MW TSGENCO BHADRADRI TPS - FGD SYSTEM	REV. 02	DATE: 02.05.2022
		SHEET 7 OF 18	

14	SB03 (LED)	High Bay, Industrial type LED fixture with integral driver suitable for mounting height > 10m.	24750	275
15	SS61 (LED)	Street light, LED fixture with integral driver.	6300	70
16	SS62 (LED)	Street light, LED fixture with integral driver.	13500	150
17	SS63 (LED)	Street light, LED fixture with integral driver.	22500	250
18	SW41 (LED)	Well glass type, vapour proof LED fixture suitable for Boiler / ESP platforms	4680	52
19	SW42 (LED)	Well glass type, vapour proof LED fixture suitable for Boiler / ESP platforms	7380	82
20	MW96 (LED)	Well glass, flame proof increased safety LED fixture with integral driver suitable for division-2, Group IIA/IIB of hazardous areas.	6000	94
21	Downlighter* (LED)	Recessed Mounted Downlighter with Integral driver aesthetically designed for Control Room/ Office	1500	18

* For Downlighter* (LED), nomenclature FC35 (LED) to be used in drawing.

Note:

- Lens, if required shall be part of LED luminaire.
- The marking of luminaires and safety requirements of luminaires shall be as per IS standards.
- LED must comply all the parameters of IS 16105 or IESNA LM-80-08.
- The Luminaire must comply all the parameters of IS 16106 or IESNA LM-79-08.
- The LED driver should comply to IEC 61347-2-13, IS 15885: Part 2: Sec 13, IEC 62384, IS 16104 and CISPR 15.
- The luminaire complete with all accessories shall comply to relevant specified standards.
- The values of minimum luminous flux & maximum measured electrical input power are specified above for the luminaire (including any accessories like driver module etc). These values shall be measured as per IS 16106 & shall not be subject to any further tolerance.
- All parameters mentioned in Section-II, Clause 5.2.1 are to be complied in totality.

Type test of LED luminaires: -:

- All equipments to be supplied shall be of type tested design. The test(s) should have been either conducted at independent laboratory or should have been witnessed by a TSGenco/Government body/PSU.
 - All acceptance and routine tests as per the specification and relevant standards shall be carried out.
 - LED fixtures type test report to be submitted for one rating each.
- In case of non-acceptance of type test during contract, same shall be done without any commercial implication.



**TECHNICAL SPECIFICATION FOR
LIGHTING FIXTURES, LAMPS AND
MISCELLANEOUS ITEMS**

**4X270 MW TSGENCO BHADRADRI TPS -
FGD SYSTEM**

SPECIFICATION NO. PE-TS-440-558-E006

VOLUME II

SECTION - I

REV. 02

DATE: 02.05.2022

SHEET 8 OF 18

ANNEXURE - A

AVERAGE LUX LEVEL & TYPE OF FIXTURES

AVERAGE LUX LEVEL & TYPE OF FIXTURES

S. No.	LOCATION	AVERAGE LUX LEVEL	TYPE OF LIGHTING FIXTURES
01	Switchgear, Charger, rectifier rooms	200	Industrial type LED.
02	FGD Central control room	300	LED, Decorative recessed, anti-glare type.
03	Office areas, Conference rooms	300	Industrial type LED.
04	Battery rooms	200	Corrosion proof LED, industrial type.
05	Transformer Area	20 (general) 50 (on equipment)	LED flood light, industrial type.
06	DG room	200	LED, medium bay, industrial type.
07	Compressor/ Pump houses	150	LED, medium/ high bay, industrial type.
08	Cable Vault	100	Industrial type LED.
09	Transfer Points	100	LED, dust proof/ dust tight well glass.
10	Corridors walk ways, staircase, toilets, wash rooms etc	100	Industrial type LED.
11	Street lighting	20	LED, street light fixture.
12	Corridors walk ways, staircase, toilets, wash rooms etc	100	Industrial type LED.
13	Unloading and maintenance bay	200	LED, medium/ high bay, industrial type.
14	Outdoor storage handling/ unloading area	20	LED flood light, industrial type.

Decorative type fixtures will be provided for false ceiling areas.



**TECHNICAL SPECIFICATION FOR
LIGHTING FIXTURES, LAMPS AND
MISCELLANEOUS ITEMS**

SPECIFICATION NO. PE-TS-440-558-E006

VOLUME II

SECTION – I

**4X270 MW TSGENCO BHADRADRI TPS -
FGD SYSTEM**

REV. 02

DATE: 02.05.2022

SHEET 9 OF 18

ANNEXURE – B

LIGHTING & LV POWER SERVICES IN DIFFERENT AREAS

S. No.	AREA	ACN	ACE	DCE	6/16A Socket	20A Socket	63/125A Socket	ELU \$
01	FGD control room	Y	Y	Y	Y*	-	-	Y
02	Switchgear room	Y	Y	Y	-	Y	Y	Y
03	Cable Vault	Y	Y	Y	-	Y	Y	-
04	Ball Mill Building (BMB) Lime Stone Handling Building	Y	-	-	-	Y	Y	Y
05	RC Pump + Oxidation Blower House (RCPH)	Y	-	-	-	Y	Y	Y
06	Gypsum Dewatering Building (GDWB)	Y	-	-	-	Y	Y	Y
07	SO2 Analyser room	Y	-	-	-	Y	Y	Y
08	ACW/DMCW pump house	Y	-	-	-	Y	Y	Y
09	Street Lighting	Y	-	-	-	-	-	-
10	Area Lighting	Y	-	-	-	-	-	-

LEGEND

ACN	AC Normal Lighting
ACE	AC Emergency
DCE	DC Emergency Lighting
Y	Yes
Y*	Yes, only in control room, offices & toilets
\$	Emergency lighting unit (ELU)

884639/2022/PS-PEM-EL



**TECHNICAL SPECIFICATION FOR
LIGHTING FIXTURES, LAMPS AND
MISCELLANEOUS ITEMS**

SPECIFICATION NO. PE-TS-440-558-E006

VOLUME II

SECTION – I

**4X270 MW TSGENCO BHADRADRI TPS -
FGD SYSTEM**

REV. 02

DATE: 02.05.2022

SHEET 10 OF 18

ANNEXURE – C

SUB-VENDOR LIST

ITEM DESCRIPTION	VENDOR NAME
LED LIGHTING FIXTURE	BAJAJ ELECTRICALS LTD.
	CROMPTON GREAVES LTD
	HAVELLS
	MIKA ENGINEERS
	SIGNIFY INNOVATIONS INDIA LTD.
	HPL ELECTRIC & POWER PVT. LTD., HARYANA
	SURYA ROSHNI LTD., UTTARAKHAND
	HALONIX TECHNOLOGIES LTD., NOIDA
	SYSKA, PUNE
	WIPRO ENTERPRISES PVT., LTD. PUNE
	FORUS ELECTRIC PVT. LTD..
LIGHTING DESIGNER	AVAIDS TECHNOVATORS PVT. LTD.
	BAJAJ ELECTRICALS LTD.
	KELSATEK SOLUTIONS PVT. LTD.
	M/s SUMANAM ENGINEERING SERVICES CONSULTANT
	M/s SURYA ROSHNI LTD
	M/s HPL ELECTRIC & POWER PVT. LTD.
	M/s MIKA ENGINEERS.
	M/s SPAN MANUFACTURING COMPANY LTD.
	M/s CITELUM INDIA PVT. LTD.
AC CONTACTORS	SIEMENS
	GE-POWER
	TELEMECHANIQUE/ SCHNEIDER ELECTRIC INDIA PVT. LTD.
	L&T
	BCH
MCCB/ELCB/MCB/RCCB/RCB	C&S Electric, U.P.
	Schneider Electric, Hyderabad (Schneider make Easypact models are not acceptable. Indian make TeSys models are acceptable)
	L&T, Maharashtra
	EATON, PONDICHERY
AUXILIARY RELAYS	ABB
	ALSTOM LTD
	JYOTI LTD.
	OEN INDIA LTD
	SIEMENS
BIMETAL RELAYS	L&T
	GE-POWER

884639/2022/PS-PEM-EL



**TECHNICAL SPECIFICATION FOR
LIGHTING FIXTURES, LAMPS AND
MISCELLANEOUS ITEMS**

SPECIFICATION NO. PE-TS-440-558-E006

VOLUME II

SECTION - I

**4X270 MW TSGENCO BHADRADRI TPS -
FGD SYSTEM**

REV. 02

DATE: 02.05.2022

SHEET 11 OF 18

	SIEMENS
	TELEMECHANIQUE/ SCHNEIDER ELECTRIC INDIA PVT. LTD.
CABLE GLANDS	ALLIED TRADERS & EXPORTERS
	ARUP ENGG & FOUNDRY WORKS
	BALIGA LIGHTING EQPT.PVT.LTD.
	COMMET BRASS PRODUCTS
	DOWELLS
	ELECTROMAC INDUSTRIES
	INCAB
CABLE LUGS	DOWELLS
	UNIVERSAL MACHINES LTD.
D.C. MCCB	CROMPTON GREAVES
	L&T
	GE-POWER
	SIEMENS
FLEXIBLE CONDUIT (PVC COATED)	REPUTED MAKE
DC CONTACTORS	SCHNEIDER ELECTRIC INDIA PVT. LTD.
	BHEL (BHOPAL)
	ELECTROMAC INDUSTRIES
	L&T
	SIEMENS
	TELEMECHANIQUE/ SCHNEIDER ELECTRIC INDIA PVT. LTD.
	GE-POWER
CONTROL SWITCHES/ SELECTOR SWITCH	KAYCEE
	GE-POWER
	ALSTOM LTD
	SCHNEIDER ELECTRIC INDIA PVT. LTD.
	M/s Shrenik & Co.
	RECOM PVT. LTD.
LT- CURRENT TRANSFORMER	SIEMENS
	AUTOMATIC ELECTRIC LTD.
	INDCOIL
	KAPPA ELECTRICALS
	PRAGATI ELECTRICALS
	PRECISE ELECTRICALS
	SILKAANS ELECT.MFG.CO.PVT.LTD
	PRAYOG ELECTRICALS PVT. LTD.
	C&S ELECTRIC LTD.
	Newtek Electricals
LT- POTENTIAL TRANSFORMER	SIEMENS
	AUTOMATIC ELECTRIC LTD.
	INDCOIL

884639/2022/PS-PEM-EL



**TECHNICAL SPECIFICATION FOR
LIGHTING FIXTURES, LAMPS AND
MISCELLANEOUS ITEMS**

SPECIFICATION NO. PE-TS-440-558-E006

VOLUME II

SECTION – I

**4X270 MW TSGENCO BHADRADRI TPS -
FGD SYSTEM**

REV. 02

DATE: 02.05.2022

SHEET 12 OF 18

	KAPPA ELECTRICALS
	PRAGATI ELECTRICALS
	PRECISE ELECTRICALS
	SILKAANS ELECT.MFG.CO.PVT.LTD
	PRAYOG ELECTRICALS PVT. LTD.
	Newtek Electricals
DC SWITCH	GE-POWER
	KAYCEE
	SIEMENS
DISTRIBUTION BOX	SHRENIK & CO.
EMER. PORTABLE LTG. SET	BAJAJ ELECTRICALS
	BAJAJ ELECTRICALS
FUSE BASE	INDO ASIAN
	GE-POWER
	L&T
	C&S ELECTRIC LTD.
	SIEMENS
	ABB
	SPACEAGE SWITCHGEARS LTD.
	SCHNEIDER ELECTRIC INDIA PVT. LTD.
	ALSTOM LTD
	ESSEN DEINKI
SFU & FUSES	C&S, UP
	SCHNEIDER ELECTRIC, HYDERABAD (SCHNEIDER MAKE EASYPACT MODELS ARE NOT ACCEPTABLE. INDIAN MAKE TESYS MODELS ARE ACCEPTABLE)
	L&T, MAHARASHTRA
GALVANISING	Jenco Industrial Corporation
	National Galvanizing Company
	Sigma Galvanising Pvt. Ltd.
	B.P. Projects PVT LTD
	Standard Galvanisers
	Steel Products
	Unitech Fabricators & Engineers Pvt. Ltd.
	Shivam Engineers & Fabricators
	B.G. Shirke Construction Technology Pvt. Ltd
	Galbro Ispat Galvanizers Pvt. Ltd.
	Eros Metals
	Industrial Perforation (India) Pvt. Ltd.
	Indmark Formtech Pvt. Ltd.

884639/2022/PS-PEM-EL



**TECHNICAL SPECIFICATION FOR
LIGHTING FIXTURES, LAMPS AND
MISCELLANEOUS ITEMS**

SPECIFICATION NO. PE-TS-440-558-E006

VOLUME II

SECTION – I

**4X270 MW TSGENCO BHADRADRI TPS -
FGD SYSTEM**

REV. 02

DATE: 02.05.2022

SHEET 13 OF 18

	Namdhari Industrial Traders Pvt. Ltd.
	Neha Galvaniser
	Patny Systems (P) Ltd.
	Parmar Metal Company
	Rukmani Electrical & Fabricators Pvt, Ltd.
	DMP Projects Pvt.Ltd.
	Vinfab Engineers India Private Limited
	Saral Projects & Processors
	Brahampuri Steels Limited
	Indiana Gratings PVT. LTD
	AVAIDS TECHNOVATORS PVT. LTD.
IND.POWER & WLDG SOCKETS	CROMPTON GREAVES
	CYCLO ELECTRIC DEVICE & SERV.CO.
	BCH
	BEST & CROMPTON
	AJMERA INDUSTRIES & ENGG. WORKS
INTERPOSING RELAY	ABB
	ALSTOM LTD
	JYOTI LTD.
	OEN INDIA LTD
	SIEMENS
INDICATING LAMPS	BCH
	C&S ELECTRIC LTD.
	ESSEN DEINKI
	VAISHNO(HOTLINE SWGR.& CONTROL)
	GE-POWER
	SIEMENS
	SCHNEIDER ELECTRIC INDIA PVT. LTD.
JUNCTION BOXES (NON FLAME PROOF)	JASPER ENGINEERS PVT. LTD.
	Electro Controls & Devices
	M/s Shrenik & Co.
	M/s PHOENIX MECANO LTD.,
	Adroit Control Engineers Pvt.Ltd.
	M/s PHOENIX MECANO LTD.,
	MIKA ENGINEERS
	M/s PHOENIX MECANO LTD.,
	BAJAJ ELECTRICALS
	AJMERA INDUSTRIES & ENGG. WORKS
	S.B. ELECTRICAL ENGINEERING CORPORATION
	RITTAL INDIA PVT. LTD.
	HPL ELECTRIC AND POWER LTD.

884639/2022/PS-PEM-EL



**TECHNICAL SPECIFICATION FOR
LIGHTING FIXTURES, LAMPS AND
MISCELLANEOUS ITEMS**

SPECIFICATION NO. PE-TS-440-558-E006

VOLUME II

SECTION – I

**4X270 MW TSGENCO BHADRADRI TPS -
FGD SYSTEM**

REV. 02

DATE: 02.05.2022

SHEET 14 OF 18

JUNCTION BOXES (FLAME PROOF)	SUDHIR SWITCHGEAR
LIGHTING DISTRIBUTION BOARDS	ADVANCE ENGG. COMPANY
	Sterling Generators Pvt. Ltd.
	MIKA ENGINEERS
	ELEXPLO ELECTRICALS PVT/ LTD.
	KMG ATOZ SYSTEMS
	UNILEC ENGINEERS PVT. LTD.
	AVAIODS TECHNOVATORS LTD.
	Adroit Control Engineers Pvt.Ltd.
	JACKSON ENGINEERS
	Adlec Systems Private Limited
	Popular Switchgears Pvt Ltd
	CANDS
	Pyrotech Electronics Pvt. Ltd.
	Positronics Pvt. Ltd.
	Industrial Switchgears & Control Pvt Ltd
M/s Vidhyut Control (I) Pvt.Ltd.	
MILESTONE SWITCHGEARS PVT. LTD.	
LIGHTING LAMP (NON LED)	WIPRO LTD.
	ESSEN DEINKI
	BAJAJ ELECTRICALS
	INSTA POWER
	PHILIPS
	HAVELLS INDIA LIMITED
	HPL
	SURYA ROSHNI LIMITED
M/s Halonix Technologies Limited	
LIGHTING LAMP (LED)	Neev Luminaries
	HAVELLS INDIA LIMITED
	BAJAJ ELECTRICALS
	SURYA ROSHNI LIMITED
	PHILIPS
	M/S HPL ELECTRIC & POWER PVT. LTD
	INSTA POWER
	Pyrotech Electronics Pvt. Ltd.
M/s Halonix Technologies Limited	
LIGHTING SWITCH , SOCKET & S/F UNIT	ELEXPLO ELECTRICALS PVT/ LTD.
	ANCHOR
	KAYCEE
	L&T
	SIEMENS
INDO ASIAN	

884639/2022/PS-PEM-EL



**TECHNICAL SPECIFICATION FOR
LIGHTING FIXTURES, LAMPS AND
MISCELLANEOUS ITEMS**

SPECIFICATION NO. PE-TS-440-558-E006

VOLUME II

SECTION – I

**4X270 MW TSGENCO BHADRADRI TPS -
FGD SYSTEM**

REV. 02

DATE: 02.05.2022

SHEET 15 OF 18

LIGHTING TRANSFORMER	AUTOMATIC ELECTRIC LTD.
	INDCOIL
	POWER PACK ENTERPRISES
	VIJAY ELECTRICALS LTD.
	GILBERT & MAXWELL
	KAPPA ELECTRICALS
Ames Impex Electricals Pvt. Ltd	
LOCAL PUSH BUTTON STATION (NON FLAME PROOF)	GE-POWER
	ASIATIC
	C&S ELECTRIC LTD.
	EVERGREEN ENGG. CO.
	TECKNIC CONTROLS
	EX-PROTECTA LIGHTING EQUIPMENT
	BALIGA ELECTRICALS
	ENPRO ENGG.
	STERLING SWGR CONTROL PVT.LTD.
	ELEXPRO ELECTRICALS PVT/ LTD.
	VAISHNO(HOTLINE SWGR & CONTROL)
	JASPER ENGINEERS PVT. LTD.
	KMG ATOZ SYSTEMS
	UNILEC ENGINEERS PVT. LTD.
	BCH
	CANDS
	SIEMENS
	SCHNEIDER ELECTRIC INDIA PVT. LTD.
TECKNIC CONTROLS	
UNITED ELECTRIC	
M/s Shrenik & Co.	
LIGHTING PANEL (NON FLAME PROOF)	MIKA ENGINEERS
	ELEXPRO ELECTRICALS PVT/ LTD.
	Vidhyut Controls (India) Pvt. Ltd.
	KMG ATOZ SYSTEMS
	UNILEC ENGINEERS PVT. LTD.
	AVAIODS TECHNOVATORS LTD.
	Adroit Control Engineers Pvt.Ltd.
	JACKSON ENGINEERS
	MILESTONE SWITCHGEARS PVT. LTD.
	Positronics Pvt. Ltd.
Pyrotech Electronics Pvt. Ltd.	
MCB	MDS SWITCHGEAR LTD
	INDO ASIAN
	SCHNEIDER ELECTRIC INDIA PVT. LTD.

884639/2022/PS-PEM-EL

**TECHNICAL SPECIFICATION FOR
LIGHTING FIXTURES, LAMPS AND
MISCELLANEOUS ITEMS**

SPECIFICATION NO. PE-TS-440-558-E006

VOLUME II

SECTION - I

**4X270 MW TSGENCO BHADRADRI TPS -
FGD SYSTEM**

REV. 02

DATE: 02.05.2022

SHEET 16 OF 18

	S&S POWER SWITCHGEAR LTD,
MODULAR SWITCH BOARD	ANCHOR
	ELEXPRO ELECTRICALS PVT/ LTD.
	HAVELLS INDIA LIMITED
RECEPTACLES - DECORATIVE	ANCHOR
	ELEXPRO ELECTRICALS PVT/ LTD.
	BAJAJ ELECTRICALS
	AJMERA INDUSTRIES & ENGG. WORKS
SWITCH BOX	ANCHOR
	ELEXPRO ELECTRICALS PVT/ LTD.
	BAJAJ ELECTRICALS
	AJMERA INDUSTRIES & ENGG. WORKS
	S.B. ELECTRICAL ENGINEERING CORPORATION
TERMINAL BLOCKS	WAGO-CONTROLS
	CONNECT WELL
	ELMEX CONTROLS PVT. LTD.
	ESSEN DEINKI
	TECHNOPLAST
	M/s PHOENIX MECANO LTD.,
	ESSEN DEINKI
TIMERS - PNEUMATIC	BCH
	ALSTOM LTD
	L&T
	TELEMECHANIQUE/ SCHNEIDER ELECTRIC INDIA PVT. LTD.
	SCHNEIDER ELECTRIC INDIA PVT. LTD.
	ELECTRONIC AUTOMATION PVT. LTD.
TIMERS - ELECTRONIC	ESSEN DEINKI
TRANSDUCERS	AUTOMATIC ELECTRIC LTD.
	SOUTHERN TRANSDUCERS
RECEPTACLE (FLAME PROOF)	BALIGA ELECTRICALS
	SUDHIR SWITCHGEAR
	FCG FLAME PROOF CONTROL GEAR
RECEPTACLE (NON FLAME PROOF)	AJMERA INDUSTRIES & ENGG. WORKS
	CROMPTON GREAVES
	CYCLO ELECTRIC DEVICE & SERV.CO.
	BCH
	BEST & CROMPTON
EMERGENCY LIGHTING UNIT (FIXED & PORTABLE TYPE)- NON FLAME PROOF	BAJAJ ELECTRICALS
	PROLITE AUTOGLO LIMITED,
	POWER PACK ENTERPRISES
	INDCOIL
	Ames Impex Electricals Pvt. Ltd

884639/2022/PS-PEM-EL



**TECHNICAL SPECIFICATION FOR
LIGHTING FIXTURES, LAMPS AND
MISCELLANEOUS ITEMS**

**4X270 MW TSGENCO BHADRADRI TPS -
FGD SYSTEM**

SPECIFICATION NO. PE-TS-440-558-E006

VOLUME II

SECTION - I

REV. 02

DATE: 02.05.2022

SHEET 17 OF 18

24V SUPPLY MODULE WITH COMPLETE ACCESSORIES	POWER PACK ENTERPRISES
	INDCOIL
	Ames Impex Electricals Pvt. Ltd
AMMETER	AUTOMATIC ELECTRIC LTD.
	RISHABH INST.PVT LTD
VOLTMETER	AUTOMATIC ELECTRIC LTD.
	RISHABH INST.PVT LTD
RCCB	C&S ELECTRIC LTD.
	SCHNEIDER ELECTRIC INDIA PVT. LTD.
	SIEMENS
	GE-POWER
	L&T
	CROMPTON GREAVES
EXIT SIGN (NON FLAME PROOF)	REPUTED MAKE
LADDER	REPUTED MAKE
PEDESTAL FAN & CEILING FAN	REPUTED MAKE
ERECTION CONSUMABLE & HARDWARES	REPUTED MAKE

Note:

The makes of all equipment/ instrument under this specification shall be subject to customer's approval in the event of order. BHEL reserves the right to accept/ reject any make or sub-vendor and to add new sub-vendors for the project after award of contract. Approval, rejection or addition of makes shall not have any price implication to the owner after award of contract.

884639/2022/PS-PEM-EL

	TECHNICAL SPECIFICATION FOR LIGHTING FIXTURES, LAMPS AND MISCELLANEOUS ITEMS	SPECIFICATION NO. PE-TS-440-558-E006	
		VOLUME II	
		SECTION – I	
	4X270 MW TSGENCO BHADRADRI TPS - FGD SYSTEM	REV. 02	DATE: 02.05.2022
SHEET 18 OF 18			

ANNEXURE – D

DOCUMENTS REQUIRED AFTER AWARD OF LOI/PO

- Schedule of drawing/ document to be submitted is part of NIT -

NOTES: -

1. Final Drawing/document list & No. shall be provided to successful bidder.
2. Vendor shall submit the dates for drawing/document submission/BHEL comments/resubmission after approval of documents.
3. In BOM each of the item to be uniquely identified with item code no. or item Sl. No. Supplier to ensure that all the items which will find separate mention in the packing list are covered in detailed BOM. Supplier to give following undertaking in BOM: " The BOM provided here completes the scope (in content and intent) of material supply under PO no. ---- dtd ----- Any additional material which may become necessary for the intended application of supplied item/package will be supplied free of cost in most reasonable time."



TECHNICAL SPECIFICATION FOR
LIGHTING FIXTURES, LAMPS AND
MISCELLANEOUS ITEMS

4X270 MW TSGENCO BHADRADRI
TPS - FGD SYSTEM

SPECIFICATION NO. PE-TS-440-558-E006

VOLUME II

SECTION - I

REVISION 02

DATE: 02.05.2022

SHEET 1 OF 7

DATA SHEET -A / C

S. No.	Description	Unit	Value
1.0	SYSTEM DESIGN DATA		
1.1	Design ambient	^o C	50
1.2	AC Supply		
a)	Rated voltage	V	415
b)	Rated frequency	Hz	50
c)	Voltage variation (permissible)	%	+10% to -10%
d)	Frequency variation (permissible)	%	+3% to -5%
e)	Combined voltage & frequency variation (sum of absolutes permissible)	%	10%
f)	System fault level & duration	kA, sec.	50kA for 1 sec.
1.3	DC Supply		
a)	Rated voltage	V	220
b)	Voltage variation (permissible)	%	+10% to -15%
c)	System fault level & duration	kA, sec.	50 kA for 1 sec.
2.0	SCOPE OF SYSTEM DESIGN ENGINEERING		Included in vendor's scope
3.0	Lighting Concept		
3.1	Types of supplies considered (other than AC Normal)		
a)	AC emergency		<input checked="" type="checkbox"/> Yes [] No
b)	DC emergency		<input checked="" type="checkbox"/> Yes [] No
c)	DC Normal		[] Yes <input checked="" type="checkbox"/> No
3.2	Diversity Factor for Sockets	%	25%
4.0	LUMINAIRES, LAMPS & ACCESSORIES		
4.1	Type of false ceiling for recessed LED luminaire		Grid False ceiling (600mm X 600mm) /Aluminium false ceiling (for Control Room).
4.2	Degree of protection for drip proof luminaires		IPW-55



TECHNICAL SPECIFICATION FOR
LIGHTING FIXTURES, LAMPS AND
MISCELLANEOUS ITEMS

4X270 MW TSGENCO BHADRADRI
TPS - FGD SYSTEM

SPECIFICATION NO. PE-TS-440-558-E006

VOLUME II

SECTION - I

REVISION 02

DATE: 02.05.2022

SHEET 2 OF 7

4.3	Flame proof luminaires		
a)	Hazardous area classification		IS 2184 Zone II Group IIA & IIB
b)	Degree of protection		IP55
c)	Mounting type for well glass		<input checked="" type="checkbox"/> Eye-bolt <input type="checkbox"/> MS Galvanised Strap <input type="checkbox"/> Screw neck
4.4	Non-integral control gear box for HPMV/HPSV lamps		Not-applicable
a)	Material		<input checked="" type="checkbox"/> CRCA sheet steel <input type="checkbox"/> Cast Aluminium LM6
b)	Sheet thickness	mm	<input checked="" type="checkbox"/> 2 for CRCA sheet <input type="checkbox"/> 3 for Cast Aluminium LM6
c)	Degree of protection		IP-55 for indoor & IPW-55 for outdoor
d)	Surface treatment		<input checked="" type="checkbox"/> Painted <input type="checkbox"/> Galvanized
e)	If galvanized		
	Process		Hot dip
	Weight of zinc (Thickness)	g/m ²	460 (65 micron)
f)	If painted		
	Paint shade as per IS 5		
	Minimum paint thickness	micron	80
4.5	Lamps		
a)	Type of LED Lamps		<input checked="" type="checkbox"/> Cool Daylight <input checked="" type="checkbox"/> White Light
4.6	Emergency Lighting Unit		
a)	Lamp type		<input type="checkbox"/> FLT <input type="checkbox"/> CFL <input checked="" type="checkbox"/> LED
b)	Nos. of Lamp		2
c)	Lamp wattage	W	6
d)	Lumen output of lamp at rated voltage	Lumen	To be furnished by vendor
e)	Type of battery		Ni-Cd/ Lead-Acid
f)	AH capacity of battery	AH	To be furnished by vendor
g)	Battery voltage	V	6
h)	Battery backup time	Hr	4
i)	In-built charger		Yes



TECHNICAL SPECIFICATION FOR
LIGHTING FIXTURES, LAMPS AND
MISCELLANEOUS ITEMS

4X270 MW TSGENCO BHADRADRI
TPS - FGD SYSTEM

SPECIFICATION NO. PE-TS-440-558-E006

VOLUME II

SECTION - I

REVISION 02

DATE: 02.05.2022

SHEET 3 OF 7

4.7	Exit Sign		
a)	Lamp type		<input type="checkbox"/> FLT <input type="checkbox"/> CFL <input checked="" type="checkbox"/> LED
b)	Nos. of Lamp		1
c)	Lamp wattage	W	12
d)	Lumen output of lamp at rated voltage	Lumen	To be furnished by vendor
e)	Type of battery		Lead-Acid
f)	AH capacity of battery	AH	To be furnished by vendor
g)	Battery voltage	V	To be furnished by vendor
h)	Battery backup time	Hr	4
4.8	24V Supply Module		
a)	Enclosure		
	Enclosure material		<input type="checkbox"/> Cast aluminium alloy <input checked="" type="checkbox"/> CRCA sheet steel
	Enclosure thickness	mm	<input type="checkbox"/> 3 for Cast aluminium alloy <input checked="" type="checkbox"/> 2 for CRCA sheet steel
	Louvers provided		<input checked="" type="checkbox"/> Yes <input type="checkbox"/> No
b)	Surface treatment		<input type="checkbox"/> Painted <input checked="" type="checkbox"/> Galvanized
c)	If galvanized		
	Process		Hot dip
	Weight of zinc (Thickness)	g/m ²	460 (65 micron)
d)	If painted		
	Paint shade as per IS 5		631
	Minimum paint thickness	micron	50
e)	Transformer		
	Rating	VA	500
	Voltage ratio	V	240 V/26.5 V
	Class of insulation		Class F, temperature rise limited to Class-B
f)	24V Hand lamp unit		
	Lamp type		<input checked="" type="checkbox"/> Halogen <input type="checkbox"/> LED
	Lamp wattage	W	40
g)	No. of outgoing sockets		4
h)	Whether cord coiling arrangement provided		<input checked="" type="checkbox"/> Yes air cooled <input type="checkbox"/> No



TECHNICAL SPECIFICATION FOR
LIGHTING FIXTURES, LAMPS AND
MISCELLANEOUS ITEMS

4X270 MW TSGENCO BHADRADRI
TPS - FGD SYSTEM

SPECIFICATION NO. PE-TS-440-558-E006

VOLUME II

SECTION - I

REVISION 02

DATE: 02.05.2022

SHEET 4 OF 7

5.0	Junction Box		
a)	Enclosure material		[] FRP [√] CRCA Sheet.
b)	Enclosure thickness	SWG	16 SWG
c)	Galvanized (applicable for CRCA sheet)		[√] Yes [] No
d)	Degree of protection		IP-55 for indoor & IPW-55 for outdoor
6.0	Industrial/ Welding Receptacle		
a)	Enclosure material		[] Heavy duty cast aluminium alloy [√] CRCA sheet steel
b)	Enclosure thickness	mm	[] 3 for cast aluminium alloy [√] 2 for CRCA sheet steel
c)	Surface treatment		[] Painted [√] Galvanized
d)	If galvanized		
	Process		Hot dip
	Weight of zinc (Thickness)	g/m ²	460 (65 micron)
e)	If painted		Not applicable
	Paint shade as per IS 5		631
	Minimum paint thickness	micron	50
f)	Degree of protection		IP-55
7.0	Decorative Receptacle		
a)	Enclosure material		[] Cast aluminium alloy [√] CRCA sheet steel
b)	Enclosure thickness	mm	[] 3 for cast aluminium alloy [√] 2 for CRCA sheet
c)	Surface treatment		[] Painted [√] Galvanized
d)	If galvanized		
	Process		Hot dip
	Weight of zinc (Thickness)	g/m ²	460 (65 micron)
e)	If painted		Not applicable
	Paint shade as per IS 5		631
	Minimum paint thickness	micron	50
f)	Degree of protection		IP-55
8.0	Switch Box		

	TECHNICAL SPECIFICATION FOR LIGHTING FIXTURES, LAMPS AND MISCELLANEOUS ITEMS	SPECIFICATION NO. PE-TS-440-558-E006	
		VOLUME II	
	4X270 MW TSGENCO BHADRADRI TPS - FGD SYSTEM	REVISION 02	DATE: 02.05.2022
		SHEET 5 OF 7	

a)	Enclosure material		<input type="checkbox"/> FRP <input checked="" type="checkbox"/> CRCA Sheet.
b)	Enclosure thickness	SWG	14 SWG
c)	Galvanized		<input checked="" type="checkbox"/> Yes <input type="checkbox"/> No
d)	Degree of protection		IP-55
9.0	Conduit (Flexible)		
a)	Type		<input checked="" type="checkbox"/> Electrogalvanized <input type="checkbox"/> Lead coated
b)	Size	mm	20
c)	Standard length	m	25 to 50
d)	Thickness of Galvanization	microns	25 microns
10.0	Cable Glands		By vendor for all incoming and outgoing cables
a)	Type		<input checked="" type="checkbox"/> Double compression <input type="checkbox"/> Single compression
b)	Material		Brass
c)	Nickel Plating provided		<input checked="" type="checkbox"/> Yes <input type="checkbox"/> No
d)	Flameproof glands with flameproof equipment		<input checked="" type="checkbox"/> Yes <input type="checkbox"/> No
11.0	Cable Lugs		By vendor for all incoming and outgoing cables
a)	Type		Crimping type/ ring type
b)	Material		Tinned copper
12.0	LADDERS		
a)	Type		<input type="checkbox"/> Free standing <input type="checkbox"/> wheel mounted <input checked="" type="checkbox"/> both
b)	Material		<input type="checkbox"/> Steel <input checked="" type="checkbox"/> Aluminium
c)	Duty		<input type="checkbox"/> Heavy <input checked="" type="checkbox"/> Medium
d)	Surface treatment		<input checked="" type="checkbox"/> Galvanised <input type="checkbox"/> Painted

Notes:

- Detailed luminaire and lamp data shall be placed by vendor after award of contract.
- Galvanization wherever applicable shall be hot dip galvanized with the weight of zinc as 460g/m² (65 micron).

	TECHNICAL SPECIFICATION FOR LIGHTING FIXTURES, LAMPS AND MISCELLANEOUS ITEMS	SPECIFICATION NO. PE-TS-440-558-E006	
		VOLUME II	
	4X270 MW TSGENCO BHADRADRI TPS - FGD SYSTEM	REVISION 02	DATE: 02.05.2022
		SHEET 6 OF 7	

LIST OF APPLICABLE STANDARDS

Lighting Fixtures and Accessories:

General and safety requirements for luminaries	IS: 1913
Flame proof enclosures of electrical apparatus	IS: 2148
Luminaires	IS: 10322
Decorative lighting outfits	IS: 5077
Flexible steel conduits for electrical wiring	IS: 3480

Lighting Panels, Switch-boxes, Receptacles and Junction Boxes:

Degree of protection provided by enclosures for low-voltage switchgear and control gear	IS: 2147
Plugs & socket outlets of rated voltage up to and including 250volts & rated current up to and including 16 Amps.	IS: 1293
Danger notice plates	IS: 2551
Low voltage switchgear and control gear	IS: 13947
Switches for domestic and similar purposes	IS: 3854
Low voltage fuses for voltages not exceeding 1000V AC or 1500 V DC	IS: 13703

Conduits, Pipes and Accessories:

Fittings for rigid steel conduit for electrical wiring	IS: 2667
Accessories for rigid steel conduits for electrical wiring	IS: 3837
Conduits for electrical installations	IS: 9537

Lighting Wires/Cables:

PVC insulated cables for working voltages up to and including 1100 V	IS: 694
XLPE insulated cables for working voltages up to and including 1100 V	IS: 7098-1
Recommended current ratings for cables. (PVC Insulated and PVC sheathed heavy duty cables and light duty cables)	IS: 3961
Conductors for insulated electric cables and flexible cords	IS: 8130
Methods of tests for cables	IS: 10810

LED Luminaries:

General Lighting. LEDs and LED modules Terms and definitions	IS: 16101:2012
Self Ballasted LED Lamps for General Lighting Services. Part-1 Safety Requirements	IS: 16102(Part 1):2012
Self Ballasted LED Lamps for General Lighting Services. Part-2 Performance Requirements	IS: 16102(Part 2):2012
LED modules for General Lighting Safety Requirements	IS: 16103(Part I):2012
Lamp control gear Part 2 particular Requirements Section 13 d.c. or a.c. Supplied Electronic control gear for LED modules	IS: 15885 (Part 2/Sec. 13):2012
d.c. or a.c. Supplied Electronic control gear for LED modules –	IS: 16104:2012

	TECHNICAL SPECIFICATION FOR LIGHTING FIXTURES, LAMPS AND MISCELLANEOUS ITEMS	SPECIFICATION NO. PE-TS-440-558-E006	
		VOLUME II	
	4X270 MW TSGENCO BHADRADRI TPS - FGD SYSTEM	REVISION 02	DATE: 02.05.2022
		SHEET 7 OF 7	

Performance Requirements	
Method of Measurement of Lumen maintenance of Solid-state Light (LED) Sources	IS: 16105:2012
Method of Electrical and photometric Measurements of Solid State Lighting (LED) Products	IS: 16106:2012
Luminaires Performance	IS: 16107:2012
Photo biological safety of Lamps and Lamp Systems	IS: 16108:2012
Cold rolled low carbon steel sheets and strips	IS: 513
Classification of degree of protection provided by enclosures	IS: 12063
Electromagnetic compatibility (EMC) – Limits (Part 3/Sec. 2) for Harmonic current emission – THD < 15% (equipment, input current < 16 Amps. per phase	IS: 14700
Environment testing: Test Z – AD: composite temperature/humidity cyclic test	IS: 9000 (Part 6)
Lamp control gear: particular requirements for (Part 2/Sec. 13) DC or AC supplied electronic control gear IS 16004 – 1 and 2) for LED modules	IS: 15885
Method for random sampling	IS: 4905

Electrical Installation Practices & Miscellaneous:

Code of practice for lighting of public thorough fare	IS: 1944
Code of practice for interior illumination.	IS: 3646
Classification of Hazardous areas (other than Mines) having flammable gases and Vapours for electrical installation	IS: 5572
Code of practice for industrial lighting	
National Electrical Code	
Indian Electricity Rules	IS: 6665
Indian Electricity Act	
Colour for ready mixed paints & enamels	IS: 5
Mild steel wires for general engineering purposes	IS: 280
Electric ceiling type fans & regulators	IS: 374
Code of practice for electrical wiring installations	IS: 732
Code of practice for installation and maintenance of power cables Up to and including 33KV rating	IS: 1255
Steel for general structural purposes	IS: 2062
Recommended practice for hot-dip galvanizing of iron and steel	IS: 2629
Methods for testing uniformity of coating of zinc coated articles	IS: 2633
Tubular steel poles for overhead power lines	IS: 2713
Code of practice for earthing	IS: 3043
Guide for safety procedures and practices in electrical work	IS: 5216
Guide for selection of electrical equipment for hazardous areas	IS: 5571
Mechanical cable glands	BS: 6121



TECHNICAL SPECIFICATION FOR
LIGHTING FIXTURES, LAMPS AND
MISCELLANEOUS ITEMS

4X270 MW TSGENCO BHADRADRI
TPS - FGD SYSTEM

SPECIFICATION NO. PE-TS-440-558-E006

VOLUME II

SECTION - I

REVISION 02

DATE: 02.05.2022

SHEET 1 OF 1

DATA SHEET -B

(Bidder to fill details of luminaires as per parameters mentioned below and furnish Data Sheet - B along with technical offer)

S. No.	DESCRIPTION	LUMINAIRE MAKE AND MODEL	MEASURED ELECTRICAL INPUT POWER (W) MAX. VALUE	TOTAL LUMINOUS FLUX (LUMEN) OF LUMINAIRE - MIN. VALUE
	MAIN SUPPLY ITEMS			
1.0	Lighting Luminaires (complete with all accessories)			
1.1	Luminaire Type FC06 (LED)			
1.2	Luminaire Type FC26 (LED)			
1.3	Luminaire Type FC30 (LED)			
1.4	Luminaire Type FC07 (LED)			
1.5	Luminaire Type FC33 (LED)			
1.6	Luminaire Type FC34 (LED)			
1.7	Luminaire Type FC32 (LED)			
1.8	Luminaire Type FC81 (LED)			
1.9	Luminaire Type SF63 (LED)			
1.10	Luminaire Type SF64 (LED)			
1.11	Luminaire Type SF66 (LED)			
1.12	Luminaire Type SB11 (LED)			
1.13	Luminaire Type SB02 (LED)			
1.14	Luminaire Type SB03 (LED)			
1.15	Luminaire Type SS61 (LED)			
1.16	Luminaire Type SS62 (LED)			
1.17	Luminaire Type SS63 (LED)			
1.18	Luminaire Type SW41 (LED)			
1.19	Luminaire Type SW42 (LED)			
1.20	Luminaire Type MW96			
1.21	LUMINAIRES TYPE FC35 DOWNLIGHTER 15-18W(LED)			

ANNEXURE – E**PACKING SPECIFICATIONS- LIGHTING FIXTURES, LAMPS & MISC. ITEMS****PACKING**

1. The material shall be packed to ensure protection against damage during transit, storage for prolonged periods and handling.
2. Lighting Fixtures, Lamps, Receptacles, Switchboards, 24V Supply modules, 24V sockets, Junction Boxes, Exit signs shall be clean and dry prior to packaging.
3. All items specified at sl. No.2 above shall be supplied in packed cartons. The tapes used for packing shall not bleed, leave residue, or damage the item when removed.
4. Fixtures & other lighting material shall be wrapped in weather proof material such as polythene sheets, air bubble sheets/ thermocol etc. The lighting fixtures shall be placed in a corrugated paperboard/ fibreboard container/ mono carton.
5. The mono cartons shall be wrapped or bagged or tied in place in master cartons. The master carton shall be taped and then wrapped with cushioning material.
6. The dimensions of cartons shall be as per manufacturer's recommendations.
7. For items like step ladder, wheel mounted ladder and flexible conduits, packing shall be as per manufacturer standard.

Note: In case Manufacturer has a different packing standard which is equivalent or better same to be submitted for approval during contract stage.

884639/2022/PS-PEM-EL

	TECHNICAL SPECIFICATION FOR LIGHTING FIXTURES, LAMPS AND MISCELLANEOUS ITEMS	SPECIFICATION NO. PE-TS-440-558-E006	
		VOLUME II	
	4X270 MW TSGENCO BHADRADRI TPS - FGD SYSTEM	REVISION 01	DATE: 02.05.2022
		SHEET 1 OF 1	

ANNEXURE-F

SCOPE MATRIX FOR BROAD ACTIVITIES

BROAD ACTIVITIES:- SCOPE MATRIX			
S. No.	Activities	Name	Remark (if any)
1	System Designer		
2	LED Fixtures' manufacturer		
	Other Items (as required for System completion) supply		
3	Supervision of Erection & commissioning - scope		
4	Design review & changes based on comments/site feedback etc. - scope		

Notes: -

1. Bidder to indicate Division of work (DOW)/ scope matrix between manufacturer & designer against each activity in the appropriate column, same to be furnished duly signed & stamped along with technical offer.

884639/2022/PS-PEM-EL



**TECHNICAL SPECIFICATION FOR
LIGHTING FIXTURES, LAMPS AND
MISCELLANEOUS ITEMS**

SPECIFICATION NO. PE-SS-999-558-E006

VOLUME II

SECTION II

REVISION: 0

DATE: 08.09.2016

SHEET 1 OF 1

SECTION – II

STANDARD TECHNICAL REQUIREMENTS

884639/2022/PS-PEM-EL



**TECHNICAL SPECIFICATION FOR
LIGHTING FIXTURES, LAMPS &
MISCELLANEOUS ITEMS**

SPECIFICATION NO. PE-SS-999-558-E006

VOLUME II

SECTION II

REVISION: 0

DATE: 8.09.2016

SHEET 1 OF 38

**TECHNICAL SPECIFICATION FOR
LIGHTING FIXTURES, LAMPS & MISCELLANEOUS ITEMS**



**TECHNICAL SPECIFICATION FOR
LIGHTING FIXTURES, LAMPS &
MISCELLANEOUS ITEMS**

SPECIFICATION NO. PE-SS-999-558-E006

VOLUME II

SECTION II

REVISION: 0

DATE: 8.09.2016

SHEET 2 OF 38

CONTENTS

<u>CLAUSE</u>	<u>DESCRIPTION</u>
1.0	INTENT OF SPECIFICATION
2.0	CODES & STANDARDS
3.0	LIGHTING SYSTEM DESCRIPTION (CONCEPTUAL VIEW)
4.0	SYSTEM DESIGN ENGINEERING
4.1	ENGINEERING INPUTS
4.2	DESIGN CRITERIA
4.3	ENGINEERING OUTPUTS
5.0	LUMINAIRES, ACCESSORIES AND LAMPS
5.1	GENERAL REQUIREMENTS OF LUMINAIRES
5.2	LUMINAIRE & OTHER ITEMS
5.3	CONTROLGEAR BOX (NON-INTEGRAL TYPE)
5.4	REFLECTORS
5.5	LAMP HOLDERS
5.6	STARTER HOLDERS
5.7	BALLASTS
5.8	STARTERS
5.9	CAPACITORS
5.10	LAMPS
5.11	JUNCTION BOXES
5.12	RECEPTACLES
5.13	CEILING FANS & REGULATORS
5.14	LIGHTING CONTROL SWITCHBOXES
5.15	CABLE GLANDS
5.16	CABLE LUGS
5.17	FLEXIBLE METALLIC CONDUITS AND FITTINGS
5.18	PVC CONDUITS
6.0	SURFACE TREATMENT
7.0	PACKING
8.0	GUARANTEED PERFORMANCE REQUIREMENTS
9.0	INSPECTION & TESTING
10.0	SPARES
11.0	TOOLS & TACKLES
12.0	DOCUMENTATION
	ANNEXURE-I: LUMINAIRE DETAILS



**TECHNICAL SPECIFICATION FOR
LIGHTING FIXTURES, LAMPS &
MISCELLANEOUS ITEMS**

SPECIFICATION NO. PE-SS-999-558-E006

VOLUME II

SECTION II

REVISION: 0

DATE: 8.09.2016

SHEET 3 OF 38

1.0 INTENT OF SPECIFICATION

- 1.1 The requirements given in specification for supply of equipment and system design engineering shall be fully complied with.
- 1.2 For the equipment of supply in vendor's scope, the "design" shall broadly cover the selection of components, materials, sizes etc. and complete responsibility of establishing the correctness of equipment design rests with the vendor.
- 1.3 It is not the intent to specify herein all the details of design and manufacture. However, the equipment shall conform in all respects to high standards of design, engineering and workmanship, and shall be capable of performing required function in a manner acceptable to Purchaser, who will interpret the meaning of drawings and specifications and shall be entitled to reject any work or material, which in his judgement is not in full accordance herewith.
- 1.4 Make of all equipment and components shall be to the approval of Purchaser. Bidder to comply to Sub-vendor list enclosed as Annexure to Section I, however same shall be subjected to end client approval without any commercial implication.

2.0 CODES & STANDARDS

- 2.1 The material shall comply with all currently applicable safety codes and statutory regulations of India as well as of the locality where the material is to be installed.
- 2.2 The material, construction, manufacture, inspection and testing shall conform to the latest revisions of standards as specified in Data Sheet-A.
- 2.3 In case of conflict between the applicable reference standard and this specification, stringent requirement shall govern.

3.0 LIGHTING SYSTEM DESCRIPTION (CONCEPTUAL VIEW)

- 3.1 All areas of plant (indoor and outdoor) shall be provided with suitable lighting arrangement to meet the functional requirements by use of various types of luminaires so as to achieve the desired quality and level of illumination.
- 3.2 Lighting system shall also cover the low voltage power services such as power receptacles and single phase feeders.
- 3.3 Lighting system shall be fed through various power sources such as AC Normal, AC Emergency and DC Emergency supply to achieve the desired reliability.
- 3.4 Power tapped from various sources shall be distributed through lighting distribution boards and lighting panels upto the various luminaires and power outlet sockets / feeders.

4.0 SYSTEM DESIGN ENGINEERING



**TECHNICAL SPECIFICATION FOR
LIGHTING FIXTURES, LAMPS &
MISCELLANEOUS ITEMS**

SPECIFICATION NO. PE-SS-999-558-E006

VOLUME II

SECTION II

REVISION: 0

DATE: 8.09.2016

SHEET 4 OF 38

Engineering shall be done by the vendor only during the contract engineering stage as the same is covered in his scope. During tender stage, bidder shall make his quotation on the basis of BOQ furnished by the purchaser with the tender document.

4.1 ENGINEERING INPUTS : Complete engineering shall be done by the vendor on the basis of documents listed below. The engineering inputs shall be furnished by purchaser. However, furnishing of these inputs shall not absolve the vendor of responsibility to visit site and get acquainted with actual site conditions.

4.1.1 Indoor Areas

- a) Room dimensions (details as covered in various layout drawings)
- b) Lighting System Design Data (LSDD) covering typical values for various types of indoor areas, indicating :
 - i. Required average illumination level
 - ii. Reflection factors for walls, ceiling and floor
 - iii. Maintenance factor
 - iv. Type of luminaire
 - v. Mounting height of luminaire
 - vi. Height of working plane
- c) AC Emergency lighting requirements
- d) DC lighting requirements
- e) Requirement of sockets
- f) Requirement of exhaust fans and fan points

4.1.2 Outdoor Areas

- a) Area geometry (details as covered in various layout drawings)
- b) Lighting System Design Data (LSDD) covering typical values for various types of outdoor areas, indicating:
 - i. Average illumination level
 - ii. Type of luminaire
 - iii. Pole heights / mounting height
 - iv. AC Emergency lighting requirement
 - v. DC lighting requirements



**TECHNICAL SPECIFICATION FOR
LIGHTING FIXTURES, LAMPS &
MISCELLANEOUS ITEMS**

SPECIFICATION NO. PE-SS-999-558-E006

VOLUME II

SECTION II

REVISION: 0

DATE: 8.09.2016

SHEET 5 OF 38

vi. Maintenance factor

c) Requirement of sockets

4.1.3 Other inputs

- a) Plot plan, Main equipment plan and TG hall floor plans (to assess quantum of area lighting drawings)
- b) Suggestive location of LDBs
- c) Suggestive power distribution scheme (SLDs)
- d) Control schemes
- e) Single phase feeder details
- f) No. of sockets / criteria for computation of no. of sockets / location of sockets etc.
- g) LDB/WDB details
- h) LP details
- i) Poles & Masts details
- j) Conduit sizes
- k) Wire sizes
- l) Earthing material sizes

4.2 DESIGN CRITERIA:

4.2.1 General Requirements of Design

- a) Lighting system shall be provided to ensure adequate visual performance, safety and reliability and shall be free from excessive glare and flicker from discharge lamps. Particular attention shall be paid to ensure that level of illumination is satisfactory in all respects including viewing of all instruments, alarms, annunciators and indicating lamps.
- b) Complete system design shall be done on the basis of inputs provided by the purchaser and in line with the laid down criteria.
- c) Requirements of sockets shall be as per the criteria / number of sockets given by the purchaser during detailed engineering stage.
- d) Complete power distribution system shall be designed keeping following criteria in view :
 - Simplicity



**TECHNICAL SPECIFICATION FOR
LIGHTING FIXTURES, LAMPS &
MISCELLANEOUS ITEMS**

SPECIFICATION NO. PE-SS-999-558-E006

VOLUME II

SECTION II

REVISION: 0

DATE: 8.09.2016

SHEET 6 OF 38

- Controlled voltage drop
- Cost effectiveness

4.2.2 Sources of Power Supply

- a) The illumination of various indoor and outdoor areas in the main plant and off site areas shall comprise of one or more of the following systems:
 - Normal AC Lighting System
 - Emergency AC Lighting System
 - DC Lighting System
- b) Arrangement and distribution of power shall depend upon the functional requirements of areas and therefore supply from all types of power sources shall not be made available to all areas. Lighting & LV power services in different areas shall be provided as per Annexure-B enclosed.
- c) 24V AC lighting for maintenance purposes (for hand lamps and/or hand operated tools) shall be supplied from 240/24V fixed/ portable lighting module.

4.2.3 Lighting philosophy

a) Normal AC Lighting System

Normal AC lighting system 415V, 3 phase, 4 wire, will be fed from lighting panels (LPs) which in turn will be fed from the lighting distribution boards (LDBs). Street lights/ flood lights shall be fed from Street Lighting Panel (SLP), Welding receptacles shall be fed from Welding DB/ MCC in offsite areas.

b) Emergency AC Lighting System

This system shall be provided for certain important areas in the main plant. The lighting fixtures connected to this system shall be normally "ON" along with the normal AC system. These will be fed from emergency lighting panels (ELPs) which in turn will be fed from 3-phase, 4-wire supply from the emergency lighting distribution boards (ELDB'S). These lights will go off for a few seconds in case of AC supply failure at Emergency Switchgear, but shall be automatically restored when Emergency Switchgear is energised by Diesel generator set.

c) DC Lighting System

At strategic locations in the main plant, a few lighting fixtures fed from 220V DC supply, shall be provided to enable safe movement of operating personnel and access to important control points during an emergency, when both the normal AC and Emergency Lighting system fail. These lighting fixtures will be fed from 220V DC LPs which in turn will be fed from DC LDBs.

The supply to the DC lighting panels shall be automatically switched ON in case of loss of AC supply at station service switchgear as well as Emergency switchgear. The DC supply will be automatically switched OFF after about 3 minutes



**TECHNICAL SPECIFICATION FOR
LIGHTING FIXTURES, LAMPS &
MISCELLANEOUS ITEMS**

SPECIFICATION NO. PE-SS-999-558-E006

VOLUME II

SECTION II

REVISION: 0

DATE: 8.09.2016

SHEET 7 OF 38

following the restoration of supply to normal AC or emergency AC lighting system.

In auxiliary /off site buildings, emergency DC lighting is to be provided through self contained DC emergency fixture at strategic locations. The fixtures shall be switched 'ON' automatically in case of failure of AC supply.

d) Street Lighting/ Flood Lighting

Street lights / flood lights will be fed from Street Lighting Panel (SLP). The number of street lights / flood lights shall be grouped in such a way that they will be fed from the nearest SLP available. Street lights shall have provision of automatic switching ON and OFF in any one of the following modes and as per the purchaser's scheme:

- i. Manual
- ii. Automatic through 00 - 24 hrs time switch
- iii. Automatic through combination of 00 - 24 hrs time switch and a remote sensing device for monitoring external illumination level. Each SLP shall be provided with a time switch and a remote light sensing device.

4.2.4 Number of Luminaires

- a) All calculations shall be done as per the input data covered under "Engineering Inputs".
- b) Total AC luminaires

Total number of AC luminaires for indoor and outdoor areas shall be calculated on the basis of point to point method by an established computer program. Optimisation criteria shall form part of street lighting calculations.

For AC emergency lighting, a specified percentage of total AC luminaires shall be considered as AC emergency luminaires. The percentage shall be informed during detail engineering.

4.2.5 Layout Considerations

a) General Layout Considerations

- i. Layout of equipment such as LDBs and LPs shall be on the basis of following criteria :
 - Ease of operation
 - Maintainability
 - Aesthetics
- ii. Luminaires shall be located to meet the functional requirements of the area. Aesthetics shall form part of layout considerations.
- iii. Due considerations shall be given to the mounting arrangement depending upon location and type of area.



**TECHNICAL SPECIFICATION FOR
LIGHTING FIXTURES, LAMPS &
MISCELLANEOUS ITEMS**

SPECIFICATION NO. PE-SS-999-558-E006

VOLUME II

SECTION II

REVISION: 0

DATE: 8.09.2016

SHEET 8 OF 38

- iv. While preparing lighting system layout drawings for air conditioned control rooms/areas having false ceilings, the vendor shall be required to interface with the Air Conditioning / Ventilation Duct layout and false ceiling layout drawings to avoid fouling / interference.
- v. The poles shall be located 1.5m away from the road edge. The buried cable shall run in hume pipe / duct bank wherever it is crossing the roads.
- vi. 240V AC, 5/15A universal socket (at least two number) shall be provided in office, store, cabin etc. The receptacles shall be provided at interval of 20m or part thereof for hand tools etc. One no. 20A, 240V AC industrial type receptacle shall be provided at suitable location in all other area as required. The receptacles shall be controlled through switch/MCBs. In hazardous area, receptacles shall be flame proof.
- vii. Suitable nos. of 63A/125A, 3 phase, 415V industrial receptacle with switch shall be provided at specific points in power plant area for welding purposes. At least one 63A/125A receptacle shall be provided in each off-site building.
- viii. 1200mm/ 1400mm sweep ceiling fans with stepped electronic regulator shall be provided for office room, store rooms and social buildings which are not covered by air-conditioned and ventilation system.

b) Conduit System

- i. Unless indicated otherwise, conduits shall originate from respective lighting panels and shall continue upto the luminaires for all indoor areas.
- ii. Conduits shall run in straight runs, parallel to building columns, walls etc. as far as practicable.
- iii. Unnecessary bends and crossings shall be avoided.
- iv. In the corrosive environment, conduit installations shall be made with corrosion proof conduits. Such requirements shall be clearly indicated while preparing BOQ.
- v. Conduits in control room and other air-conditioned areas shall be surface mounted on the roof above false ceiling. However vertical drops of conduits shall be through column flanges or grooved to the wall, finally covered for better aesthetics.

c) Wiring

- i. Each circuit from LP shall be taken in a separate conduit.
- ii. Wiring of AC normal, AC emergency & DC emergency lighting system shall be carried out in separate conduits.



**TECHNICAL SPECIFICATION FOR
LIGHTING FIXTURES, LAMPS &
MISCELLANEOUS ITEMS**

SPECIFICATION NO. PE-SS-999-558-E006

VOLUME II

SECTION II

REVISION: 0

DATE: 8.09.2016

SHEET 9 OF 38

- iii. Receptacle wiring shall be distinct from lighting conduits. No two phase circuits shall be run in the same conduit. However different circuits of same phase may be laid in the same conduit.
- iv. Maximum three nos. of receptacles shall be loop-in & loop-out in a circuit.
- v. Filling area of wires in conduit shall not exceed 40% of the conduit area.
- vi. Wiring shall be done with following conductor sizes :
 - Luminaires – 2.5 sq. mm
 - 5A plug & socket – 2.5 sq. mm
 - 5/15A and 20A plug & socket – 4 sq.mm
- vii. Wiring shall be designed for the uniformly distributed spread of luminaires on each phase i.e. R, Y,B. Distribution of luminaires on these phases shall be such so that there is generally uniform light intensity in the event of failure of one or two phases.
- viii. Luminaires located in offices, stores, laboratories, toilets etc. shall be individually or group controlled.

d) Cabling

- i. Cables shall be considered wherever it is not desirable to run the insulated wires due to long runs or for any other valid reason.
- ii. Cable Schedule shall be prepared for all cable connections.

4.3 ENGINEERING OUTPUTS:

Vendor shall prepare and submit following documents and drawings for purchaser's approval :

- a) Lighting calculations for indoor areas covering details such as room dimensions (length, width, height), illumination level, reflection factors (walls, ceiling, floor), maintenance factor, type of luminaire, mounting height of luminaire, room index, coefficient of utilisation, no. of luminaires (AC Normal & AC Emergency), lumen output of each luminaire, reference drawings and remarks.
- b) Lighting calculations for outdoor areas covering average illumination level, type of luminaire, chart for illumination level at various points in the area; location (coordinates), number and height of poles; type, number (normal + emergency) and orientation of luminaires etc. Calculated values of average and minimum illumination level as obtained through computer package shall also be furnished. Dot density plots for lux level shall be furnished if available in the computer package.
- c) Single line diagrams of power distribution upto Lighting Panels. Separate drawing for complete lighting distribution shall also be prepared by vendor.



**TECHNICAL SPECIFICATION FOR
LIGHTING FIXTURES, LAMPS &
MISCELLANEOUS ITEMS**

SPECIFICATION NO. PE-SS-999-558-E006

VOLUME II

SECTION II

REVISION: 0

DATE: 8.09.2016

SHEET 10 OF 38

- d) Loads on each phase of LP and LDB with consideration of diversity factor for sockets.
- e) Layout drawings for each indoor area indicating location of luminaires, sockets, fan points, exhaust fans, LDBs and LPs. Details of type of luminaires, source of power supply (AC Normal, AC Emergency, DC Normal and DC Emergency). Bill of Material shall also be covered which shall include unit wise requirements of luminaires and other items.
- f) Layout drawings for each outdoor area indicating location of poles / towers, orientation of luminaires, sockets and LPs. Details of pole height / mounting height, type of luminaires, source of power supply (AC Normal, AC Emergency, DC Emergency). Bill of Material shall also be covered for various types of luminaires.
- g) Conduit layout drawings with wiring and load distribution details as superimposed on the area layout drawings indicated above. Drawings shall include Bill of Material for conduits, wires etc.
- h) Wiring and load distribution details for outdoor areas.
- i) Master Bill of Material (to be submitted at regular intervals of engineering progress) including all items required for the complete lighting system viz. lighting fixtures, lamps, Lighting DBs, Welding DBs, lighting panels, conduits, PVC wires etc.
- j) In case of revised inputs or site feedback, preparation and submission of revised engineering outputs shall also be in the scope of vendor.
- k) Calculation for selection of number and size of containers
- l) Packing procedures drawings.

5.0 LUMINAIRES, ACCESSORIES AND LAMPS

5.1 GENERAL REQUIREMENTS OF LUMINAIRES

- a) All luminaires and accessories shall be designed for continuous operation and shall be suitable for the system design data given in Data Sheet A.
- b) Luminaires shall be complete with accessories mounted inside the luminaire assembly. Lamps shall be supplied separately as per BOQ.
- c) All luminaires and accessories shall be suitable for operation in the atmospheric conditions prevailing at site.
- d) Power factor for fluorescent lamp luminaires shall be 0.9 or more and that for HPMV/ HPSV luminaires shall be 0.85 or more. Power factor correction capacitors shall be provided for this purpose.



**TECHNICAL SPECIFICATION FOR
LIGHTING FIXTURES, LAMPS &
MISCELLANEOUS ITEMS**

SPECIFICATION NO. PE-SS-999-558-E006

VOLUME II

SECTION II

REVISION: 0

DATE: 8.09.2016

SHEET 11 OF 38

- e) Luminaires shall be designed for minimum glare. No bright spots should appear from the lamp or from the reflectors.
- f) All accessories shall be wired upto a terminal block or a separate weather proof metallic terminal box suitable for 2.5 sq. mm. copper wire termination.
- g) All internal wiring shall be of PVC or silicon rubber insulation, capable of withstanding the maximum temperature to which it will be subjected under specified service conditions without deterioration.
- h) All luminaires and accessories including the breathing holes shall be vermin proof.
- i) Surface Treatment:
- All surfaces after manufacture shall be thoroughly cleaned and degreased. Pre-treatment of surfaces shall be as per the applicable standard. Pretreated surfaces shall be free from rust, sharp edges, scales and burrs.
 - Finish of surfaces shall be non-porous, smooth and unfaded.
- j) All metal parts of the luminaires shall be bonded and connected to the earthing terminal. Earthing terminal shall be suitable for connecting 14 SWG GI wire.
- k) Flood lights shall be provided with base frame / base plate for mounting on structural steel members / wall.
- l) All weather proof luminaires shall have the control gear housed in a weather proof enclosure with necessary gaskets, mounting bracket, locking screws etc.

5.2 LUMINAIRE TYPES & OTHER ITEMS

5.2.1 General requirements depending upon type of luminaire are listed below. Specific requirements of each luminaire are indicated in "Luminaire Details" enclosed as Annexure-I.

a) Channel Mounted Luminaires (Fluorescent Luminaires)

- Channel mounted luminaires, except the special purpose luminaires, shall have CRCA sheet steel base plate / rail / channel / box / side panels / housing as per "Luminaire Details". Sheet shall be completely stove enameled unless mentioned vitreous enameled in "Luminaire Details". Colour of enamel shall be grey on all non-reflecting surfaces and white on reflecting surfaces.
- Twin fluorescent luminaires shall be wired in lead-lag circuit to minimise stroboscopic effect.
- Luminaires suitable for surface mounting shall also be suitable for pendant mounting. Knockouts of 20mm ET conduit fixation shall be provided for this purpose.



**TECHNICAL SPECIFICATION FOR
LIGHTING FIXTURES, LAMPS &
MISCELLANEOUS ITEMS**

SPECIFICATION NO. PE-SS-999-558-E006

VOLUME II

SECTION II

REVISION: 0

DATE: 8.09.2016

SHEET 12 OF 38

b) Decorative Fluorescent Luminaires

- Decorative luminaires shall be provided with one of the following as per “Luminaire Details” :
 - i. Perspex acrylic diffuser.
 - ii. High purity, anodised aluminium, mirror optic reflectors with anodised aluminium matt finish transverse fins to control glare.
 - iii. Opal polystyrene louvers and sheet steel side panels.
 - iv. Vertical metallic louvers finished in stove enamelled white and with sheet steel side panels.
- End plates of decorative luminaires shall be of high impact polystyrene or sheet metal finished in black colour.
- Diffusers and louvers for the fluorescent lamps shall be made of high impact polystyrene sheet and shall have no yellowing property over a prolonged period of use.
- Recessed type decorative luminaires shall be suitable for mounting with gypsum boards / luxalon / plaster of Paris/aluminium frame false ceiling of standard size as per Data Sheet A and “Luminaire details”.

c) Industrial Fluorescent Luminaires (General Purpose)

- Additional reflectors, wherever provided, shall be easily removable type.

d) Industrial Fluorescent Luminaires (Special Purpose)

- Luminaires for chemical vapour (acidic / alkaline) laden environment shall be of cast aluminium controlgear box and end boxes. Controlgear housing shall have detachable, one piece neoprene gasket cover to make it weather proof. Design shall be suitable for chemically charged environment.
- Luminaires for corrosive and dust laden environment shall be made of tray type sheet steel housing and transparent acrylic visor supported by a galvanised sheet steel frame, fitted to the housing with gasket all around. Cable entry shall be from the side of luminaire. Luminaire shall be totally dust and vapour proof.
- Luminaires for highly corrosive environment shall have with sheet aluminium/ polycarbonate housing. controlgear housing, CRCA sheet steel controlgear tray with a stove enamelled white reflector. A clear acrylic cover of dish shape, secured to canopy by stainless steel toggle and neoprene gasket lining, shall be provided at the bottom.



**TECHNICAL SPECIFICATION FOR
LIGHTING FIXTURES, LAMPS &
MISCELLANEOUS ITEMS**

SPECIFICATION NO. PE-SS-999-558-E006

VOLUME II

SECTION II

REVISION: 0

DATE: 8.09.2016

SHEET 13 OF 38

- Luminaires for drip proof environment such as street lighting fluorescent luminaire shall have sheet aluminium canopy, a detachable reflector-cum-controlgear housing, clear ribbed acrylic cover held in aluminium frame. Luminaire shall have the degree of protection IP:55 unless mentioned otherwise in Data Sheet A. Luminaire shall be suitable for side entry mounting with the pole bracket arm.

e) Bay Type Luminaires

- Luminaires shall be designed for following indoor applications:
 - i) High bay
 - ii) Medium bay
 - iii) Low bay
- Luminaires shall have top mounted, cast aluminium controlgear housing. Housing shall have cooling fins and canopy for easy access to the components. Canopy shall be hinged at one end and wing screw bolted at the other end.
- Controlgear shall be connected to the detachable lamp housing at the bottom such that heat dissipation is proper and distributed.
- Lamp housing-cum-reflector shall be made from spun aluminium, electrochemically brightened and anodised.
- Lamp housing for the dust laden environment shall be totally enclosed type. A clear toughened glass cover shall be attached to the lamp housing with an aluminium frame and neoprene gasket. Luminaire shall be provided with a safety chain for toughened glass.
- Mounting arrangement shall consist of MS brackets with an anti-vibration eye-bolt.
- Side mounted controlgear box shall be provided for low bay luminaires, if mentioned in "Luminaire Details".

f) Well Glass Luminaires

- Well glass luminaires shall be suitable for dust and vapour laden environment.
- Luminaires shall be provided with a die-cast aluminium canopy and heat resistant well glass, fitted with a ring type gasket.
- All well glass luminaires shall be provided with vitreous enamelled reflector.
- Zinc plated MS wire guard shall be provided for protection of well glass.



**TECHNICAL SPECIFICATION FOR
LIGHTING FIXTURES, LAMPS &
MISCELLANEOUS ITEMS**

SPECIFICATION NO. PE-SS-999-558-E006

VOLUME II

SECTION II

REVISION: 0

DATE: 8.09.2016

SHEET 14 OF 38

- Separate side mounted and top connected controlgear box shall be provided for use with HPMV & HPSV lamps. Separate, non-integral controlgear box is also acceptable.
- Integral controlgear box, where applicable, shall be of die cast aluminium material with one piece neoprene gasket between the box and its cover to make it dust and vapour proof.
- Luminaires shall be conduit mounted type for incandescent lamps and surface mounting type for HPMV & HPSV lamps.

g) Flame Proof Well Glass Luminaires

- Housing material shall be cast aluminium alloy LM6. Housing outer surface shall be provided with cooling fins.
- Flame proof luminaires shall be provided with heavy toughened well glass cemented in a retaining ring.
- Zinc-coated / chrome-plated MS chain connected to the main body and glass retaining ring shall be provided.
- A detachable terminal box at the top shall be provided.
- Neoprene gaskets, where needed, shall be provided for weather proof construction and indoor and outdoor application.
- Two cable entries of 20mm ET conduit shall be provided with one flame proof plug.
- Luminaires shall be suitable for the hazardous areas as classified in Data Sheet A. Design of flame proof luminaire shall be supported by the type test report for flame proofness from a government or government approved independent laboratory.

h) Street Lighting Luminaires (Other than Fluorescent Luminaire)

- These luminaires shall be suitable for street lighting and general purpose outdoor area lighting.
- Luminaire housing shall be one piece cast aluminium alloy to accommodate lamp housing and controlgear for lamp wattage upto 150 watts. For lamp wattage above 150 watts, controlgear housing shall be of cast aluminium alloy whereas lamp housing shall be of deep drawn aluminium.
- Inside finish of the lamp housing shall be stove enamelled white. Optical control shall be provided with two high purity, electro brightened and anodised side reflectors.



**TECHNICAL SPECIFICATION FOR
LIGHTING FIXTURES, LAMPS &
MISCELLANEOUS ITEMS**

SPECIFICATION NO. PE-SS-999-558-E006

VOLUME II

SECTION II

REVISION: 0

DATE: 8.09.2016

SHEET 15 OF 38

- Clear acrylic bowl fitted with a rubber gasket and easily removable type shall be secured to the lamp housing.
- Provision shall be made for adjustment of lamp location for proper focussing.
- Luminaires shall be suitable for mounting with pole bracket arm.

i) Flood Lighting Luminaires

- Flood light lamp housing and reflector shall be separate from controlgear box. Requirements of controlgear box are specified elsewhere.
- Lamp reflectors shall be of high purity spun aluminium attached to the cast aluminium lamp holder housing at the rear. Lamp holder housing shall be provided with cooling fins.
- Reflector shall be closed from the front by heat resistant toughened glass and synthetic "S" type weather proof gasket.
- Luminaire shall be provided with special lamp centering and focussing device ensuring good beam control.
- MS mounting bracket shall allow fixation of the flood light in any position in a horizontal plane and the flood light can be locked in at any set angle in the vertical plane. Cast iron base and / or two protector scales shall also be provided where specified in "Luminaire Details"
- Design shall permit replacement of lamp from the rear without disturbing the previously set aiming angles. Special guide pins shall also be provided for protecting the lamps from damage while replacing.

j) Halogen Flood Lighting Luminaire

- Luminaires shall be compact in design with aluminium alloy housing and three piece highly polished and anodised reflector assembly.
- Toughened glass panel in the front shall be provided with silicon gaskets.
- Lamp replacement from the front is also acceptable.

k) Post Top Lanterns

- Luminaire shall comprise of a spun aluminium canopy, opal acrylic diffuser and a cast aluminium spigot.
- Controlgear shall be integral type and shall be housed in the spigot.
- Luminaire shall be supplied without mounting pole.

l) Bulk Head (Flame Proof)



**TECHNICAL SPECIFICATION FOR
LIGHTING FIXTURES, LAMPS &
MISCELLANEOUS ITEMS**

SPECIFICATION NO. PE-SS-999-558-E006

VOLUME II

SECTION II

REVISION: 0

DATE: 8.09.2016

SHEET 16 OF 38

- Bulk head luminaires shall be used for the locations where explosion or fire hazard exists.
- Luminaire shall be made of cast iron housing with integral terminal box.
- Front of the luminaire shall be covered with flat toughened glass cemented into a retaining ring.
- Lamp replacement shall be from the front.
- Control gear box for HPMV lamps shall be integral to the housing.
- MS fixing straps shall be provided for mounting.
- Luminaire shall be stove enameled grey outside and white inside.
- Terminal box shall be provided with 20 mm ET conduit entry.
- Complete luminaire shall be suitable for the hazardous area as classified in Data Sheet A. Type test certificate for flame proofness test from government or government approved independent laboratory shall be submitted.

m) Bulk Head (Weather Proof)

- Luminaire shall be suitable for indoor / outdoor applications having weather proof features.
- The luminaire shall comprise of die cast aluminium alloy body of dish shape.
- Luminaire shall have a heat resistant prismatic cover held in a weather proof gasket.
- Luminaire shall be stove enamelled grey outside and white inside.
- Glass cover shall have a galvanised wire protection.
- Luminaire shall be provided with locking arrangement with Allen key to prevent pilferage.
- Luminaire shall be suitable for use with incandescent lamp upto 100W.
- Provision for 20 mm ET conduit entry shall be provided at the bottom.

n) LED type Luminaires:

- LED Luminaires shall be used for the lighting if specified in BOQ as part of NIT.
- In false ceiling area LED luminaires shall be recessed mounting type & in non-false ceiling area the LED luminaires shall be surface mounting type.



**TECHNICAL SPECIFICATION FOR
LIGHTING FIXTURES, LAMPS &
MISCELLANEOUS ITEMS**

SPECIFICATION NO. PE-SS-999-558-E006

VOLUME II

SECTION II

REVISION: 0

DATE: 8.09.2016

SHEET 17 OF 38

- The individual lamp wattage for LED shall be upto 3 watt.
- The LED chip efficacy shall be min 120 Lm/W.
- The LED used in the luminaires shall have colour rendering index (CRI) of Min 1. Colour designation of LED shall be “cool day light” (min 5700K) type.
- The LED luminaire shall have minimum life of 25,000 burning hours with 80% of lumen maintenance at the end of the life.
- The beam angle for LED chip shall be 120 degrees.
- The max. junction temperature of LED shall be 85 deg C, further the lumen maintenance at this temperature shall be min 90%.
- The THD of LED Luminaires shall be less than 10%. Further the EMC shall be as per IS 14700. The power factor of the luminaire shall not be less than 0.9.
- The marking on luminaire & safety requirements of luminaire shall be as per IS standards.
- Suitable heat sink with proper thermal management shall be designed & provided in the luminaire.
- The connecting wires used inside the system, shall be low smoke halogen free, fire retardant PTFE cable.
- Fuse protection shall be provided in input side specifically for LED luminaires.
- Care shall be taken in the design that there is no water stagnation anywhere. The entire housing shall be dust and water proof protection as per IS 12063.
- Driver Circuit: LED modules and drivers shall be compatible to each other. The LED module driver's ratings and makes shall be as recommended by corresponding LED manufacturer. LED Drivers may have following control & protections:
 - Suitable precision current control of LED.
 - Open Circuit Protection
 - Short Circuit Protection
 - Over Temperature Protection
 - Overload Protection

o) Emergency Lighting Luminaires



**TECHNICAL SPECIFICATION FOR
LIGHTING FIXTURES, LAMPS &
MISCELLANEOUS ITEMS**

SPECIFICATION NO. PE-SS-999-558-E006

VOLUME II

SECTION II

REVISION: 0

DATE: 8.09.2016

SHEET 18 OF 38

- The luminaire shall be automatic having in-built battery.
- Battery shall have integral charging unit.
- Charger shall be suitable for operation as per system design data.
- The battery enclosure shall be suitably painted and ventilated for the performance with sealed lead acid battery, as applicable.

5.3 CONTROLGEAR BOX (NON-INTEGRAL TYPE)

- a) Boxes shall have weatherproof construction and shall be provided with one piece neoprene gasket.
- b) Boxes shall be provided with HRC fuse mounted on a removable tray. Boxes shall be provided with all necessary components having a neat layout arrangement such that it is possible to test, inspect or replace any component without difficulty.
- c) Boxes shall be suitable for mounting on structures, walls and columns.
- d) Suitable number of terminals shall be provided for looping-in and looping-out of cable connections and also connections to the luminaire(s).
- e) Cable / conduit knock-outs shall be for each loop-in and loop-out connection and also connection to the luminaire(s).

5.4 REFLECTORS

- a) Reflectors shall be made of sheet steel or aluminium as applicable.
- b) The aluminium reflectors shall be made of high purity aluminium sheet. Sheet will be polished, electrochemically brightened and anodised.
- c) Wherever reflectors are separate from housing, they shall be securely attached to the luminaire by means of easily accessible fastening devices such that they are readily removable from the housing for maintenance.

5.5 LAMP HOLDERS

- a) Holders shall be resistant to wear and shall be smooth in operation.
- b) Contacts shall be of durable quality.
- c) Holders shall hold the lamp under condition of shock and vibration.
- d) Lamp holders for fluorescent lamp shall be spring loaded, bi-pin, rotor type with low contact resistance.



**TECHNICAL SPECIFICATION FOR
LIGHTING FIXTURES, LAMPS &
MISCELLANEOUS ITEMS**

SPECIFICATION NO. PE-SS-999-558-E006

VOLUME II

SECTION II

REVISION: 0

DATE: 8.09.2016

SHEET 19 OF 38

- e) Live parts of the holder shall not be exposed when the lamp is inserted or removed in case of fluorescent luminaires.
- f) Lamp holders for HPMV & HPSV lamps shall be of porcelain material.
- g) Holders shall be screw type for HPSV & HPMV lamps. Holders for incandescent lamps shall be screw type, unless mentioned otherwise in Data sheet A.
- h) Lamp holders for incandescent lamps shall be of brass or porcelain.

5.6 STARTER HOLDERS

- a) Starter holders shall be designed and manufactured as per the applicable standard.

5.7 BALLASTS

- a) Fluorescent fixtures shall have electronic ballasts. Ballasts shall be totally enclosed type.
- b) Ballasts shall be easily removable type.
- c) Core shall be made of low loss, electrical grading stampings.
- d) End connections shall be made available in a terminal block, rigidly fixed to the ballast enclosure.
- e) Ballasts shall be free from humming.
- f) Ballast shall be provided separately for each lamp in a multi-lamp luminaire.
- g) Tappings shall be provided to set the voltage within range for HPMV & HPSV luminaires.

5.8 STARTERS

- a) Starters shall be made of aluminium material. Plastic or any other material if used shall be subject to purchaser's approval.
- b) Starters shall have bi-metal electrodes.
- c) Starter shall be replaceable without the use of any tool and without disturbing any accessory or lamp.
- d) Starters shall have high mechanical strength.
- e) Starters shall be provided with radio interference suppressing capacitors.
- f) Starters shall have brass contacts.



**TECHNICAL SPECIFICATION FOR
LIGHTING FIXTURES, LAMPS &
MISCELLANEOUS ITEMS**

SPECIFICATION NO. PE-SS-999-558-E006

VOLUME II

SECTION II

REVISION: 0

DATE: 8.09.2016

SHEET 20 OF 38

5.9 CAPACITORS

- a) Capacitors shall have constant value of capacitance, suitable for operation at supply voltage.
- b) Capacitors shall be hermetically sealed, preferably in a metal enclosure to prevent seepage of impregnant and ingress of moisture.

5.10 LAMPS

- a) Lamps shall be suitable for use in any position.
- b) Lamps shall be capable of withstanding small vibrations without breakage to filaments / electrodes and lead-in wire.

5.10.1 Type of Lamps

- a) Fluorescent Lamp
 - i. Anode rings shall be provided to prevent blackening of the ends.
 - ii. Lamp caps shall be two pin type at each end.
- b) Incandescent (GLS) Lamps
 - i. Incandescent lamps shall be "clear" type.
- c) Mercury Vapour Lamps
 - i. Lamp caps shall be screw type.
- d) Sodium Vapour Lamps
 - i. Lamps shall be ovoid shaped with diffusing powder coating.
 - ii. Lamps shall be provided with external igniters and rapid restart facility.
 - iii. Lamp caps shall be screw type.
- e) Halogen Lamps
 - i. Lamps shall be double ended linear type.
 - ii. Lamps shall be of immediate start type.
 - iii. Design of lamps shall ensure high performance and high efficiency.

5.11 JUNCTION BOXES

- a) Junction boxes with terminals shall be supplied for branching and terminating lighting wires/cables whenever required, as specified.



**TECHNICAL SPECIFICATION FOR
LIGHTING FIXTURES, LAMPS &
MISCELLANEOUS ITEMS**

SPECIFICATION NO. PE-SS-999-558-E006

VOLUME II

SECTION II

REVISION: 0

DATE: 8.09.2016

SHEET 21 OF 38

b) Construction Features

- i. The junction boxes shall be fabricated out of material & thickness as specified in Datasheet-A and shall be of rectangular shape. The cover shall be hinged or bolted with captive nuts and bolts and shall be provided with neoprene gasket lining all over.
- ii. The junction boxes shall be provided with suitable knock outs/ gland plates for conduit/ cable connection. The conduit connection shall be properly sealed. The junction boxes meant for cable connection shall be complete with removable gland plates, glands and cable lugs, as required. The junction boxes shall be provided with two earthing terminals suitable for GI earthing wires.
- iii. The junction boxes shall be weather proof type conforming to IP-55..
- iv. The boxes and cover shall be hot dip galvanised. Junction boxes for corrosive areas like DM Plant, water treatment plant etc. shall have additional epoxy/acrylic coating of thickness not less than 50microns on outer surface.
- v. The junction boxes shall be suitable for mounting on wall, columns, etc. The brackets, bolts, nuts, screws and any other erection accessories required for erection shall be included.

c) Terminals

- i. Multiway terminal blocks of approved type and make complete with galvanised screws, nuts, washers and marking strips shall be furnished for terminating the lighting wires.
- ii. All the terminals blocks shall be of 650V grade one piece construction with insulating barriers. These terminals shall be made of copper alloy and shall be stud type. Each terminal provided on junction box shall be suitable for terminating two numbers of aluminium conductors of the size as specified without any damage to the conductors or looseness.

d) The junction boxes shall be of following types:

Type	Description
JB-F	Provided with four (4) way stud type terminals for terminating upto 2 nos. 10 mm ² stranded aluminium conductors on each terminal, suitable for outdoor installations.
JB-FE	Same as above but with an additional epoxy coating of 50 micron thickness.
JB-S	Provided with four (4) way stud type terminals, each terminal suitable for terminating upto two nos. of 3.5Cx50 mm ² stranded aluminium conductors & with one no.6A HRC fuse and link.



**TECHNICAL SPECIFICATION FOR
LIGHTING FIXTURES, LAMPS &
MISCELLANEOUS ITEMS**

SPECIFICATION NO. PE-SS-999-558-E006

VOLUME II

SECTION II

REVISION: 0

DATE: 8.09.2016

SHEET 22 OF 38

5.12 RECEPTACLES

- a) Receptacle unit shall consist of socket outlet with associated switch and plug. The socket outlet and switch shall be flush mounted on a box which shall be suitable for mounting on wall or steel structures.
- b) Receptacle boxes shall be fabricated from material with thickness mentioned in Data Sheet A.
- c) Steel boxes shall be hot dip galvanised/ painted as specified in Datasheet-A.
- d) The boxes shall have conduit knock-outs and shall be suitable for cable entry of the size to be specified by purchaser during detailed engineering.
- e) The boxes shall be provided with neoprene rubber gaskets to make them moisture and dust proof.
- f) Suitable loop-in and loop-out terminals shall be provided inside the box. Terminals for incoming and outgoing shall be suitable for the size of conductor of cables.
- g) The receptacle units shall be of the following types:
 - I. Type RA: It shall have the following:
 - i. 20A, 240V, 1-phase, 2 pole, 3-pin (third pin scrapping earth) porcelain, metal clad socket with a metallic cover tied to it.
 - ii. Rotary, heavy duty 20A switch conforming to applicable standard.
 - iii. Shrouded, die-cast aluminium plug.
 - iv. It shall be combined interlocked weather proof industrial unit.
 - v. Mechanical interlock shall be provided as follows :
 - Switch can be put ON only when plug is fully engaged.
 - Plug can be withdrawn only when switch is in OFF position.
 - Cover can be opened only when switch is in OFF position.
 - vi. The arrangement should ensure that water does not enter the plug when socket is ON.
 - vii. Loop-in loop-out terminals shall be provided inside the box suitable for 10 mm² Al conductor.
 - II. Type RB: It shall have the following:



**TECHNICAL SPECIFICATION FOR
LIGHTING FIXTURES, LAMPS &
MISCELLANEOUS ITEMS**

SPECIFICATION NO. PE-SS-999-558-E006

VOLUME II

SECTION II

REVISION: 0

DATE: 8.09.2016

SHEET 23 OF 38

- i. Combination of 5A & 15A, 240V, 1-phase, 2 pole, 3-pin, third pin grounded socket with integral piano key type 15A switch, flush mounted on decorative bakelite (6 mm thick)/ perspex (3 mm thick) sheet as cover of the boxes.
- ii. Loop-in loop-out terminals similar to type RA shall be provided. These will be located in office areas.
- III. Type RC: It shall have the following:
- i. 63A, 415V, 3-phase-neutral earth, metal clad socket with cover
- ii. Rotary, heavy duty 63A switch conforming to applicable standard.
- iii. Shrouded, die-cast aluminium plug
- iv. It shall be combined, interlocked weather proof industrial unit.
- v. Mechanical interlock shall be same as that are applicable for RA type receptacles
- vi. The receptacle boxes shall be suitable for entry and exit of 3.5CX70 mm² Al conductor PVC cable and loop-in loop-out terminals for the same shall be provided such that not more than one core is terminated at one terminal. Removable, undrilled cable gland plate shall be provided. Tinned copper lugs and double compression cable glands shall also be supplied by the bidder.
- IV. Type RD: It shall have the following:
- i. 125A, 415V, 3-phase-neutral earth, metal clad socket with cover.
- ii. Rotary, heavy duty 125A switch conforming to applicable standard.
- iii. Shrouded, die-cast aluminium plug
- iv. It shall be combined, interlocked weather proof industrial unit.
- v. Mechanical interlock shall be same as that are applicable for RC type receptacles
- vi. The receptacle boxes shall be suitable for entry and exit of 3.5CX95 mm² Al conductor PVC cable and loop-in loop-out terminals for the same shall be provided such that not more than one core is terminated at one terminal. Removable, undrilled cable gland plate shall be provided. Tinned copper lugs and double compression cable glands shall also be supplied by the bidder.
- V. Type RE: It shall have the following:



**TECHNICAL SPECIFICATION FOR
LIGHTING FIXTURES, LAMPS &
MISCELLANEOUS ITEMS**

SPECIFICATION NO. PE-SS-999-558-E006

VOLUME II

SECTION II

REVISION: 0

DATE: 8.09.2016

SHEET 24 OF 38

- i. 5A, 240V, 1-phase, 2 pole, 3-pin, third pin grounded socket with integral piano key type 5A switch, flush mounted on decorative bakelite (6 mm thick)/ perspex (3 mm thick) sheet as cover of the boxes.
- ii. Loop-in loop-out terminals similar to type RA shall be provided. These will be located in office areas.

5.13 CEILING FAN & REGULATORS

- a) The bidder shall supply the following ceiling fans complete with suspension rod, canopy and accessories and regulators:
 - i. 1200 mm sweep
 - ii. 1400 mm sweep
- b) The fan motor shall be totally enclosed. The motor winding shall be of copper wire provided with double or reinforced class-E insulation.
- c) The fan shall have three (3) well balanced blades. Precaution shall be taken in the manufacture of fan as well as regulators to ensure reasonable degree of silence at all speeds.
- d) The regulator shall be electronic type with stepped/smooth (stepless) control of approved make.

5.14 LIGHTING CONTROL SWITCH-BOXES

- a) The switch-boxes shall be of bent steel construction, fabricated of 1.6 mm thick MS steel with 6 mm thick decorative bakelite or 3 mm thick perspex sheet cover. The boxes shall be hot dip galvanised.
- b) The switch-boxes shall be suitable for surface mounting as well as flush mounting in brick walls. They shall be flush mounted in the walls in the office areas where false ceiling is provided.
- c) Switch-boxes shall have conduit knock-out on two sides. Adequate provision shall be made for ventilation of these boxes. Conduit knock-out sizes shall be as per conduit layout drgs.
- d) Switches shall be of piano-key type having quick-make, quick-break mechanism, provided with position marking, suitable for mounting on insulating plate. The switches shall be suitable for 1-phase, 240V, 50 Hz supply. They shall conform to relevant standards. The switches shall be supplied loose and shall be fixed at site according to requirement.
- e) All components housed in the switch-boxes shall be wired to an outgoing junction box by 1.5 mm² Cu wire. The junction box shall have adequate nos. of terminals.



**TECHNICAL SPECIFICATION FOR
LIGHTING FIXTURES, LAMPS &
MISCELLANEOUS ITEMS**

SPECIFICATION NO. PE-SS-999-558-E006

VOLUME II

SECTION II

REVISION: 0

DATE: 8.09.2016

SHEET 25 OF 38

- f) The size of switch-boxes shall be adequately chosen to accommodate the no. of switches and fan regulator boxes specified below. Fan regulators shall be supplied separately.
- i. Type SWB1 - Switch board with 1 no. 5A switch, JB type SW1.
 - ii. Type SWB2 - 3 nos. 5A switches and 1 no. fan regulator, JB type SW2.
 - iii. Type SWB2a - 4 nos. 5A switches, JB type SW2.
 - iv. Type SWB3 - 7 nos. 5A switches, 3 nos. fan regulator, JB type SW3.
 - v. Type SWB3a - 8 nos. 5A switches, JB type SW3.

JB details for lighting control switch boxes are as below :

JB-SW1 Provided with four (4) way stud type terminals, each terminal suitable for terminating upto two nos. of 10 mm² stranded aluminium conductor.

JB-SW2 Similar to the JB-SW1 but provided with ten (10) way terminals.

JB-SW3 Similar to the JB-SW1 but provided with eighteen (18) way terminals.

5.15 CABLE GLANDS

- a) Whether specifically mentioned or not, cable glands of suitable sizes shall be supplied along with each equipment for power and control cables.
- b) Rubber components used in the gland shall be of neoprene.
- c) Name / trade name of manufacturer, type no. and applicable range of outer diameter of cable shall be engraved / indelibly printed on the cable gland.

5.16 CABLE LUGS

- a) All equipment shall be supplied with the power and control cable lugs of suitable size, whether specifically mentioned or not.
- b) Name / trade name and size of lug shall be engraved/ indelibly printed on each cable lug.

5.17 FLEXIBLE METALLIC CONDUITS AND FITTINGS

- a) Flexible metallic conduits shall generally conform to the requirements of IS:3480.
- b) Flexible conduits shall be made of strip steel, which shall be of cold rolled mild steel. The strip shall be of uniform width and thickness throughout.
- c) The strip for making flexible conduit shall be wound tightly and so overlapped in subsequent helicals that no openings are seen in normal position.



**TECHNICAL SPECIFICATION FOR
LIGHTING FIXTURES, LAMPS &
MISCELLANEOUS ITEMS**

SPECIFICATION NO. PE-SS-999-558-E006

VOLUME II

SECTION II

REVISION: 0

DATE: 8.09.2016

SHEET 26 OF 38

- d) The surface of the strip shall be thoroughly cleaned before application of protective coating. Pre-treatment, before galvanization, shall conform to IS:6005.
- e) The strip shall be electro-galvanized to a minimum thickness of 25 microns as per IS 3480.
- f) Flexible conduits shall be lead coated for application in high temperature zones if specifically mentioned in Data Sheet A.
- g) The conduit shall have uniform diameter throughout its length. The internal surface of all conduits shall be free from burrs and sharp edges and suitable for pulling insulated cables and wires without damage.

5.18 PVC CONDUITS

- a) PVC conduits shall generally conform to the requirements of IS: 9537(Part I & Part III).

6.0 SURFACE TREATMENT

- 6.1 All metal parts and the surfaces (exterior & interior) of equipment, unless stated otherwise in case of reflectors, shall be degreased by dipping in hot alkaline solution and rubbed with wire brush to remove oil & scale from them & then rinsed in water. Alternatively, they may be shot / sand blasted.
- 6.2 Parts shall be pickled by dipping in hydrochloric acid tank to remove the rust from the surfaces formed during storage of sheets & then rinsed to remove traces of the acid. The cleaning and pretreatment of all metal parts shall be as per applicable standard.
- 6.3 The surfaces to be painted shall then be prepared by phosphatizing to protect them from further rusting & to create a good bond with the paint. The pretreatment shall conform to the applicable standard.
- 6.4 All parts shall then be subjected to a coat of red oxide primer paint.
- 6.5 All inside and outside surfaces of panel shall be spray painted with synthetic enamel of the shade as per Data Sheet A.
- 6.6 Electrostatic or powder painting shall be acceptable subject to purchaser's approval.
- 6.7 Wherever possible, finished parts shall be coated with peelable compound by spraying method to protect the finished product from scratches, grease, dirty and oily spots during handling and transportation.

7.0 PACKING



**TECHNICAL SPECIFICATION FOR
LIGHTING FIXTURES, LAMPS &
MISCELLANEOUS ITEMS**

SPECIFICATION NO. PE-SS-999-558-E006

VOLUME II

SECTION II

REVISION: 0

DATE: 8.09.2016

SHEET 27 OF 38

- 7.1 Vendor shall furnish packing procedure along with packing drawing at contract stage for applicable items for purchaser approval.
- 7.2 Containers adequate for storing 70% of P.O. quantity material at site are to supplied. Vendor shall furnish suitable justification to purchaser during detailed engineering for the number and size of containers being supplied.
- 7.3 Specification for the sea worthy packing, if enclosed, for the export jobs shall form part of the specification.

8.0 GUARANTEED PERFORMANCE REQUIREMENTS

- 8.1 The vendor shall guarantee satisfactory performance of the equipment supplied under all conditions and requirement as laid down by this specification.
- 8.2 Vendor shall ensure satisfactory performance for lighting system designed by them at site.

9.0 INSPECTION & TESTING

- 9.1 Bidder shall confirm compliance with the BHEL Standard Quality Plan (PE-QP-999-558-E006) without any deviations. The equipment which are not covered in the Quality Plan shall be tested as per the QP to be submitted by bidder. In case bidder has reference QP agreed with ultimate customer, same can be submitted for specific project after award of contract for BHEL/ ultimate customer's approval. There shall be no commercial implication to BHEL on account of any changes in QP during contract stage.
- 9.2 All the components and completely assembled equipment shall be tested as per the latest edition of standards. Charges for these tests shall be deemed to be included in equipment price.
- 9.3 All the specified type and routine tests shall be carried out to verify the rating and performance of the equipment. Where valid type test certificates in evidence of equipment performance claimed are available & approved by purchaser, the requirements for conducting type tests may be waived. The general arrangement of object under test shall be to purchaser's approval.
- 9.4 All manufacturing processes viz. machining, sheet forming, electroplating, wire routing, cleating & crimping, assembly, surface preparation shall conform to good manufacturing practices.
- 9.5 Inspection for dimensional & visual checks especially of the following, with respect to contract drawings, documents & standards shall be conducted:
 - a) General sturdiness & rigidity of equipment
 - b) Surface finishing
 - c) Gasketting
 - d) Inter-changeability



**TECHNICAL SPECIFICATION FOR
LIGHTING FIXTURES, LAMPS &
MISCELLANEOUS ITEMS**

SPECIFICATION NO. PE-SS-999-558-E006

VOLUME II

SECTION II

REVISION: 0

DATE: 8.09.2016

SHEET 28 OF 38

e) Constructional features viz. location, accessibility & marking of components, segregation, accessibility to live parts (shrouding) etc.

f) Completeness of scope

9.6 Equipment shall be liable for rejection if tolerances on the values of dimensions, power consumption, impedances, temperature rise etc. exceed the specified values by purchaser and / or standards.

10.0 SPARES

10.1 Mandatory spares (if applicable) are indicated in BOQ-cum-price schedule.

10.2 Erection & commissioning spares are included in the bidder's scope of supply. BE&C spares are indicated in BOQ-cum-price schedule.

10.3 A list of recommended O&M spares quantities for a duration of 3 years A shall be filled up in the applicable schedule / format and submitted by bidder along with offer. However, the acceptance of the same shall not be binding on purchaser.

11.0 TOOLS AND TACKLE

11.1 Tools & tackle which are essential to facilitate assembly, adjustments, erection, maintenance & dismantling of equipment shall be provided as part of equipment supplied.

11.2 The above tools shall be supplied along with the initial consignment of equipment so as to be available prior to erection but may not be used for erection purposes.

11.3 Vendor shall also submit a list of recommended tools and tackle. Acceptance of these tools and tackle shall not be a binding on the purchaser.

11.4 Schedule of tools & tackle shall be filled up by bidder.

12.0 DOCUMENTATION

12.1 Documents to be submitted by the vendor immediately after award of contract

a) Bar chart of activities of manufacture, testing, inspection and despatch.

12.2 Documents to be submitted during detailed engineering of contract

12.2.1 Engineering documents (refer clause 4.3) to be generated by the vendor, if applicable.

a) Lighting calculations for indoor areas.

b) Lighting calculations for outdoor areas.

c) SLD of power distribution upto LPs.

d) Power load on each LP & LDB

e) Layout drawings for indoor areas

f) Layout drawings for outdoor areas.



**TECHNICAL SPECIFICATION FOR
LIGHTING FIXTURES, LAMPS &
MISCELLANEOUS ITEMS**

SPECIFICATION NO. PE-SS-999-558-E006

VOLUME II

SECTION II

REVISION: 0

DATE: 8.09.2016

SHEET 29 OF 38

- g) Conduit layout drawings.
- h) Wiring and load distribution details for outdoor areas.
- i) Master Bill of Material.
- j) Packing Procedure & drawing.
- k) Calculation for selection of no. & size of container.

12.2.2 Other documents :

- a) Final Quality Plans
- b) Technical data sheet
- c) Polar curves, zonal flux diagram and CoU charts of luminaires.
- d) Complete design calculations for arriving at number of luminaires.
- e) Fixing / mounting details of luminaires and other items.
- f) General arrangement drawings of following:
 - i. Luminaires
 - ii. Receptacles
 - iii. 24 V Supply module
- g) Field Quality Plan as per General Technical Conditions.
- h) Control Scheme for fluorescent, HPMV and HPSV luminaires.
- i) Schematic drawings for LDBs / LPs.
- j) Type test certificates.
- k) Catalogues / leaflets

12.3 Operation and Maintenance (O&M) manual :

The document shall comprise of installation, operating and maintenance instructions for various items / components. The O&M manual shall include the following :

- a) Write ups / instructions / procedures for
 - i. Storage at site.
 - ii. Unpacking.
 - iii. Handling at site.
 - iv. Erection.
 - v. Pre-commissioning / commissioning tests.
 - vi. Operating procedures.
 - vii. Maintenance procedures.
 - viii. Precautions to be taken during operation and maintenance work.
 - ix. Trouble shooting charts covering problems, cause and solution.
- b) Approved Technical Data Sheets.
- c) Technical leaflet of various items / components.



**TECHNICAL SPECIFICATION FOR
LIGHTING FIXTURES, LAMPS &
MISCELLANEOUS ITEMS**

SPECIFICATION NO. PE-SS-999-558-E006

VOLUME II

SECTION II

REVISION: 0

DATE: 8.09.2016

SHEET 30 OF 38

- d) Copies of the type, acceptance and routine test certificates in bound volume.
- e) Details of all components liable to be replaced during the life of the equipment.
- f) List of maintenance tools required.
- g) List of testing equipment required.

12.4 AS BUILT DRAWINGS

- a) Preparation of as-built drawings shall be in the scope of vendor.
- b) The as-built drawings shall be prepared on the basis of marked up copies received from the erection contractor.
- c) Entire work of as-built drawings shall be to the satisfaction of purchaser.



**TECHNICAL SPECIFICATION FOR
LIGHTING FIXTURES, LAMPS &
MISCELLANEOUS ITEMS**

SPECIFICATION NO. PE-SS-999-558-E006

VOLUME II

SECTION II

REVISION: 0 DATE: 8.09.2016

SHEET 31 OF 38

ANNEXURE-I

LUMINAIRE DETAILS

LUMINAIRE CODING SCHEME

1.0 Code Structure

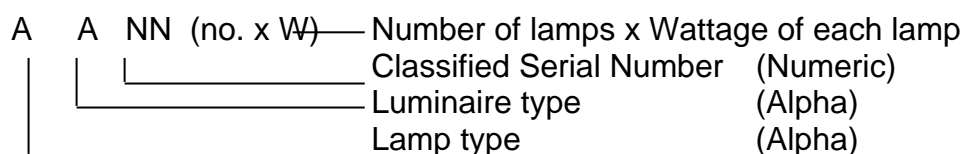

2.0 Lamp types

- | | | | |
|----|---|---|----------------|
| a) | F | - | Fluorescent |
| b) | M | - | Mercury Vapour |
| c) | S | - | Sodium Vapour |
| d) | T | - | Tungsten |
| e) | H | - | Halogen |

3.0 Luminaire types

- | | | | |
|----|---|---|-------------------------------|
| a) | C | - | Channel Mounted (Fluorescent) |
| b) | B | - | Bay Mounted |
| c) | W | - | Well Glass |
| d) | S | - | Street Lighting |
| e) | F | - | Flood Lighting |
| f) | H | - | Bulk Head |
| g) | P | - | Post Top Lantern |
| h) | E | - | Emergency Lighting |
| i) | X | - | Others |

4.0 Serial Numbers

- | | | |
|----|---------|------------------------------|
| a) | 01 - 20 | General Purpose (Industrial) |
| b) | 21 - 40 | Decorative |
| c) | 41 - 50 | Vapour Proof |
| d) | 51 - 60 | Dust Proof |
| e) | 61 - 70 | Drip Proof |
| f) | 81 - 90 | Corrosion Proof |
| g) | 91 - 99 | Flame Proof |

NOTES :

1. Flood lighting luminaires to have non-integral control gearbox.
2. All other luminaires shall have integral control gearbox, unless specifically mentioned otherwise in enclosed sheets.
3. For more details of each luminaire, refer specification.



**TECHNICAL SPECIFICATION FOR
LIGHTING FIXTURES, LAMPS &
MISCELLANEOUS ITEMS**

SPECIFICATION NO. PE-SS-999-558-E006

VOLUME II

SECTION II

REVISION: 0

DATE: 8.09.2016

SHEET 32 OF 38

1.0 Fluorescent Lamp Luminaires

- | | | | |
|------|------|--------|---|
| 1.1 | FC01 | 1 x 28 | Fluorescent, industrial box type base without any cover. |
| 1.2 | FC02 | 2 x 28 | Fluorescent, industrial box type base without any cover. |
| 1.3 | FC03 | 1 x 28 | Fluorescent, industrial box type base and stove enamelled side reflectors. |
| 1.4 | FC04 | 2 x 28 | Fluorescent, industrial box type base and stove enamelled side reflectors. |
| 1.5 | FC05 | 1 x 28 | Fluorescent, industrial box type base and vitreous enamelled side reflectors. |
| 1.6 | FC06 | 2 x 28 | Fluorescent, industrial box type base and vitreous enamelled/ anodized glossy side reflectors. |
| 1.7 | FC07 | 1 x 18 | Fluorescent, industrial box type base and vitreous enamelled side reflectors operating on 220V DC input supply. |
| 1.8 | FC21 | 1 x 28 | Fluorescent, decorative with 3 side perspex acrylic diffuser. |
| 1.9 | FC22 | 2 x 28 | Fluorescent, decorative with 3 side perspex acrylic diffuser. |
| 1.10 | FC23 | 1 x 28 | Fluorescent, decorative, recessed type with perspex acrylic diffuser. |
| 1.11 | FC24 | 2 x 28 | Fluorescent, decorative, recessed type with perspex acrylic diffuser. |
| 1.12 | FC25 | 1 x 28 | Fluorescent, decorative, recessed type with mirror optic reflector. |
| 1.13 | FC26 | 2 x 28 | Fluorescent, decorative, recessed type with mirror optic reflector. |
| 1.14 | FC27 | 2 x 28 | Fluorescent, decorative with opal polystyrene louvers. |
| 1.15 | FC28 | 2 x 28 | Fluorescent, decorative, recessed type with opal polystyrene louvers. |
| 1.16 | FC29 | 2 x 28 | Fluorescent, decorative with vertical metallic louvers. |
| 1.17 | FC30 | 4 x 14 | Fluorescent, decorative, recessed type, 600 x 600 size with perspex acrylic diffuser. |
| 1.18 | FC31 | 4 x 20 | Fluorescent, decorative, recessed type, 600 x 600 size with opal polystyrene louvers. |



**TECHNICAL SPECIFICATION FOR
LIGHTING FIXTURES, LAMPS &
MISCELLANEOUS ITEMS**

SPECIFICATION NO. PE-SS-999-558-E006

VOLUME II

SECTION II

REVISION: 0

DATE: 8.09.2016

SHEET 33 OF 38

- | | | | |
|------|------|--------|---|
| 1.19 | FC32 | 2 x 20 | Fluorescent, decorative, surface mounted with mirror optic reflector. |
| 1.20 | FC33 | 1 x 18 | Fluorescent, decorative, recessed type with mirror optic reflector operating on 220V DC input supply. |
| 1.21 | FC34 | 1 x 18 | Fluorescent, dust proof, totally enclosed type with sheet steel housing operating on 220V DC input supply |
| 1.22 | FC41 | 2 x 28 | Fluorescent, vapour proof with end boxes and controlgear box of cast Al. |
| 1.23 | FC51 | 2 x 28 | Fluorescent, dust proof, totally enclosed type with sheet steel housing. |
| 1.24 | FC61 | 1 x 28 | Fluorescent, street light with sheet aluminium canopy and ribbed acrylic cover. |
| 1.25 | FC62 | 2 x 28 | Fluorescent, street light with sheet aluminium canopy and ribbed acrylic cover. |
| 1.26 | FC81 | 2 x 28 | Fluorescent, corrosion proof, totally enclosed type with sheet aluminium/ polycarbonate housing. |

2.0 High Pressure Mercury Vapour (HPMV) Lamp Luminaire

- | | | | |
|------|------|----------|--|
| 2.1 | MB01 | 1 x 250 | Mercury, high bay, industrial type. |
| 2.2 | MB02 | 1 x 400 | Mercury, high bay, industrial type. |
| 2.3 | MB03 | 1 x 1000 | Mercury, high bay, industrial type. |
| 2.4 | MB04 | 1 x 250 | Mercury, high bay, totally enclosed industrial type. |
| 2.5 | MB05 | 1 x 400 | Mercury, high bay, totally enclosed industrial type. |
| 2.6 | MB06 | 1 x 250 | Mercury, high bay with non-integral controlgear box. |
| 2.7 | MB07 | 1 x 400 | Mercury, high bay with non-integral controlgear box. |
| 2.8 | MB11 | 1 x 250 | Mercury, medium bay, industrial type. |
| 2.9 | MB12 | 1 x 400 | Mercury, medium bay, industrial type. |
| 2.10 | MB13 | 1 x 250 | Mercury, medium bay, totally enclosed industrial type. |
| 2.11 | MB14 | 1 x 400 | Mercury, medium bay, totally enclosed industrial type. |



**TECHNICAL SPECIFICATION FOR
LIGHTING FIXTURES, LAMPS &
MISCELLANEOUS ITEMS**

SPECIFICATION NO. PE-SS-999-558-E006

VOLUME II

SECTION II

REVISION: 0

DATE: 8.09.2016

SHEET 34 OF 38

- | | | | |
|------|------|---------|--|
| 2.12 | MB17 | 1 x 80 | Mercury, low bay, industrial type. |
| 2.13 | MB18 | 1 x 125 | Mercury, low bay, industrial type. |
| 2.14 | MB19 | 1 x 80 | Mercury, low bay, totally enclosed industrial type. |
| 2.15 | MB20 | 1 x 125 | Mercury, low bay, totally enclosed industrial type. |
| 2.16 | MW41 | 1 x 80 | Mercury, well glass, vapour proof with vitreous enamelled reflector. |
| 2.17 | MW42 | 1 x 125 | Mercury, well glass, vapour proof with vitreous enamelled reflector. |
| 2.18 | MW51 | 1 x 80 | Mercury, well glass, dust proof with vitreous enamelled reflector. |
| 2.19 | MW52 | 1 x 125 | Mercury, well glass, dust proof with vitreous enamelled reflector. |
| 2.20 | MW91 | 1 x 80 | Mercury, well glass, flame proof with vitreous enamelled reflector and cast aluminium alloy LM6 housing. |
| 2.21 | MW92 | 1 x 125 | Mercury, well glass, flame proof with vitreous enamelled reflector and cast aluminium alloy LM6 housing. |
| 2.22 | MW93 | 1 x 80 | Mercury, well glass, flame proof with vitreous enamelled reflector and cast aluminium alloy LM6 housing |
| 2.23 | MW94 | 1 x 125 | Mercury, well glass, flame proof with vitreous enamelled reflector and cast aluminium alloy LM6 housing. |
| 2.24 | MW95 | 1 x 80 | Mercury, well glass, flame proof increased safety luminaire with vitreous enamelled reflector and cast aluminium alloy LM6 housing for Div.-2 areas. |
| 2.25 | MW96 | 1 x 125 | Mercury, well glass, flame proof increased safety luminaire with vitreous enamelled reflector and cast aluminium alloy LM6 housing for Div. 2 areas. |
| 2.26 | MW98 | 1 x 125 | Mercury, well glass, flame proof increased safety luminaire with vitreous enamelled reflector and cast aluminium alloy LM6 housing |
| 2.27 | MS61 | 1 x 125 | Mercury, street light with one piece cast aluminium body. |
| 2.28 | MS62 | 1 x 250 | Mercury, street light with two piece cast aluminium body. |
| 2.29 | MS63 | 1 x 400 | Mercury, street light with two piece cast aluminium body. |



**TECHNICAL SPECIFICATION FOR
LIGHTING FIXTURES, LAMPS &
MISCELLANEOUS ITEMS**

SPECIFICATION NO. PE-SS-999-558-E006

VOLUME II

SECTION II

REVISION: 0

DATE: 8.09.2016

SHEET 35 OF 38

- | | | | |
|------------|--|---------|--|
| 2.30 | MF61 | 1 x 250 | Mercury, flood light, general purpose. |
| 2.31 | MF62 | 1 x 400 | Mercury, flood light, heavy duty type. |
| 2.32 | MF63 | 2 x 400 | Mercury, flood light, heavy duty type. |
| 2.33 | MP21 | 1 x 80 | Mercury, post top lantern |
| 2.34 | MP22 | 1 x 125 | Mercury, post top lantern |
| 3.0 | High Pressure Sodium Vapour (HPSV) Lamp Luminaire | | |
| 3.1 | SB01 | 1 x 150 | Sodium, high bay, industrial type. |
| 3.2 | SB02 | 1 x 250 | Sodium, high bay, industrial type. |
| 3.3 | SB03 | 1 x 400 | Sodium, high bay, industrial type. |
| 3.4 | SB04 | 1 x 150 | Sodium, high bay, totally enclosed industrial type. |
| 3.5 | SB05 | 1 x 250 | Sodium, high bay, totally enclosed industrial type. |
| 3.6 | SB06 | 1 x 400 | Sodium, high bay, totally enclosed industrial type. |
| 3.7 | SB07 | 1 x 150 | Sodium, high bay with non-integral controlgear box. |
| 3.8 | SB08 | 1 x 250 | Sodium, high bay with non-integral controlgear box. |
| 3.9 | SB09 | 1 x 400 | Sodium, high bay with non-integral controlgear box. |
| 3.10 | SB11 | 1 x 150 | Sodium, medium bay, industrial type. |
| 3.11 | SB12 | 1 x 250 | Sodium, medium bay, industrial type. |
| 3.12 | SB13 | 1 x 150 | Sodium, medium bay, totally enclosed industrial type. |
| 3.13 | SB14 | 1 x 250 | Sodium, medium bay, totally enclosed industrial type. |
| 3.14 | SB17 | 1 x 70 | Sodium, low bay, industrial type. |
| 3.15 | SB18 | 1 x 150 | Sodium, low bay, industrial type. |
| 3.16 | SB19 | 1 x 70 | Sodium, low bay, totally enclosed industrial type. |
| 3.17 | SB20 | 1 x 150 | Sodium, low bay, totally enclosed industrial type. |
| 3.18 | SW41 | 1 x 70 | Sodium, well glass, vapour proof with vitreous enamelled/
powder coated type reflector. |



**TECHNICAL SPECIFICATION FOR
LIGHTING FIXTURES, LAMPS &
MISCELLANEOUS ITEMS**

SPECIFICATION NO. PE-SS-999-558-E006

VOLUME II

SECTION II

REVISION: 0

DATE: 8.09.2016

SHEET 36 OF 38

3.19	SW42	1 x 150	Sodium, well glass, vapour proof with vitreous enamelled/ powder coated type reflector.
3.20	SW51	1 x 70	Sodium, well glass, dust proof with vitreous enamelled reflector.
3.21	SW52	1 x 150	Sodium, well glass, dust proof with vitreous enamelled reflector.
3.22	SW91	1 x 70	Sodium, well glass, flame proof with vitreous enamelled reflector and cast aluminium alloy LM6 housing.
3.23	SW92	1 x 150	Sodium, well glass, flame proof with vitreous enamelled reflector and cast aluminium alloy LM6 housing.
3.24	SW93	1 x 70	Sodium, well glass, flame proof with vitreous enamelled reflector and cast aluminium alloy LM6 housing.
3.26	SW95	1 x 70	Sodium, well glass, flame proof increased safety luminaire with vitreous enamelled reflector and cast aluminium alloy LM6 housing for Div. 2 areas.
3.27	SW96	1 x 150	Sodium, well glass, flame proof increased safety luminaire with vitreous enamelled reflector and cast aluminium alloy LM6 housing for Div. 2 areas.
3.28	SS61	1 x 70	Sodium, street light with one piece cast aluminium body.
3.29	SS62	1 x 150	Sodium, street light with one piece cast aluminium body.
3.30	SS63	1 x 250	Sodium, street light with two piece cast aluminium body.
3.31	SS64	1 x 400	Sodium, street light with two piece cast aluminium body.
3.32	SF61	1 x 250	Sodium, flood light, general purpose.
3.33	SF62	1 x 400	Sodium, flood light, general purpose.
3.34	SF63	1 x 250	Sodium, flood light, heavy duty type.
3.35	SF64	1 x 400	Sodium, flood light, heavy duty type.
3.36	SF65	2 x 250	Sodium, flood light, heavy duty type.
3.37	SF66	2 x 400	Sodium, flood light, heavy duty type.
3.38	SP21	1 x 70	Sodium, post top lantern.



**TECHNICAL SPECIFICATION FOR
LIGHTING FIXTURES, LAMPS &
MISCELLANEOUS ITEMS**

SPECIFICATION NO. PE-SS-999-558-E006

VOLUME II

SECTION II

REVISION: 0

DATE: 8.09.2016

SHEET 37 OF 38

4.0 Tungsten Lamp Luminaires

- | | | | |
|------|------|---------|--|
| 4.1 | TW41 | 1 x 100 | Tungsten, well glass, vapour proof with vitreous enamelled reflector. |
| 4.2 | TW42 | 1 x 200 | Tungsten, well glass, vapour proof with vitreous enamelled reflector. |
| 4.3 | TW51 | 1 x 100 | Tungsten, well glass, dust proof with vitreous enamelled reflector. |
| 4.4 | TW52 | 1 x 200 | Tungsten, well glass, dust proof with vitreous enamelled reflector. |
| 4.5 | TW91 | 1 x 100 | Tungsten, well glass, flame proof with vitreous enamelled reflector. |
| 4.6 | TW92 | 1 x 200 | Tungsten, well glass, flame proof with vitreous enamelled reflector. |
| 4.7 | TW95 | 1 x 100 | Tungsten, well glass, increased safety (Div. 2) with vitreous enamelled reflector. |
| 4.8 | TW96 | 1 x 200 | Tungsten, well glass, increased safety (Div. 2) with vitreous enamelled reflector. |
| 4.9 | TB21 | 1 x 60 | Tungsten, bulk head, weather proof. |
| 4.10 | TB22 | 1 x 100 | Tungsten, bulk head, weather proof. |
| 4.11 | TB91 | 1 x 100 | Tungsten, bulk head, flame proof. |
| 4.12 | TB92 | 1 x 200 | Tungsten, bulk head, flame proof. |
| 4.13 | TP21 | 1 x 200 | Tungsten, post top lantern. |
| 4.14 | TE02 | 1 x 20 | Tungsten, portable emergency unit with rechargeable battery. |
| 4.15 | TE02 | 1 x 40 | Tungsten, portable emergency unit with rechargeable battery. |
| 4.16 | TX01 | 1 x 60 | Tungsten, dispersive vitreous enamelled reflector. |
| 4.17 | TX02 | 1 x 100 | Tungsten, dispersive vitreous enamelled reflector. |
| 4.18 | TX03 | 1 x 75 | Decorative recessed mounting luminaire suitable for comptalux lamp. |
| 4.19 | TX04 | 1 x 100 | Decorative recessed mounting luminaire suitable for comptalux lamp. |



**TECHNICAL SPECIFICATION FOR
LIGHTING FIXTURES, LAMPS &
MISCELLANEOUS ITEMS**

SPECIFICATION NO. PE-SS-999-558-E006

VOLUME II

SECTION II

REVISION: 0

DATE: 8.09.2016

SHEET 38 OF 38

4.20 TX05 2 x 100 Double obstruction aviation light of cast Al. alloy with red glass.

5.0 Halogen

5.1 HF61 1 x 300 Halogen, flood light, drip proof.

5.2 HF62 1 x 500 Halogen, flood light, drip proof.

5.3 HF63 1 x 750 Halogen, flood light, drip proof.

5.4 HF64 1 x 1000 Halogen, flood light, drip proof.

	MANUFACTURER/ BIDDER/ SUPPLIER NAME & ADDRESS		STANDARD QUALITY PLAN				SPEC. NO :		DATE:				
			CUSTOMER :				QP NO.:PE-QP-999-558-E001, R04		DATE: 23.06.2020				
			PROJECT:				PO NO.:		DATE:				
			ITEM: LIGHTING FIXTURES, LAMPS & MISC. ITEMS		SYSTEM:STATION LIGHTING SYSTEM		SECTION: II		SHEET 1 OF 10				
SL NO.	COMPONENT & OPERATIONS	CHARACTERIST ICS	CLASS	TYPE OF CHECK	QUANTUM OF CHECK		REFERENCE DOCUMENT	ACCEPTAN CE NORMS	FORMAT OF RECORD		AGENCY	REMARKS	
1	2	3	4	5	6		7	8	9	*	**		
					M	C/ N				D	M	C	N

1.0 CONVENTIONAL TYPE LIGHTING FIXTURES

A	Bought out items / in-process checks													
1.1	Lamps	Make rating & type	Major	Visual	1 sample per type	-	Approved Data Sheet for rating & type , Make to be BIS approved with CML number	Approved Data Sheet for rating & type , Make to be BIS approved with CML number			P/ V *	-	-	Refer note No. 1
1.2	Electronic Ballast (if applicable)	Certificate of compliance	Major	Visual	Mnfr std.	-	Approved Data Sheet	Certificate of compliance by ballast manufacturer /lighting fixture that supplier that ballast meets all Approved Data Sheet requirements.	Certificate of compliance		P/ V *	-	-	Refer note No. 1
		THD and pf check	Major	Electrical	Mnfr std.	-	Approved Data Sheet	THD<=10% , pf>=0.9 for FH type and pf>=0.95 for other type of florescent lighting fixtures	Inspection report		P/ V *	-	-	Refer note No. 1

BHEL					
ENGINEERING			QUALITY		
	Sign & Date	Name		Sign & Date	Name
Prepared by:	 09.07.2020	MEET SAGAR SINGH RAJPAL	Checked by:	09.07.20	KUNAL GANDHI
Reviewed by:		PRAVEEN DUTTA	Reviewed by:	Digitally signed by JAISWAL	by RITESH KUMAR

BIDDER/ SUPPLIER	
Sign & Date	
Seal	

FOR CUSTOMER REVIEW & APPROVAL			
Doc No:			
	Sign & Date	Name	Seal
Reviewed by:			
Approved by:			

Date: 2020.07.10 20:27:48 +05'30'

	MANUFACTURER/ BIDDER/ SUPPLIER NAME & ADDRESS		STANDARD QUALITY PLAN				SPEC. NO :		DATE:	
			CUSTOMER :				QP NO.:PE-QP-999-558-E001, R04		DATE: 23.06.2020	
			PROJECT:				PO NO.:		DATE:	
			ITEM: LIGHTING FIXTURES, LAMPS & MISC. ITEMS		SYSTEM:STATION LIGHTING SYSTEM		SECTION: II		SHEET 2 OF 10	

SL NO.	COMPONENT & OPERATIONS	CHARACTERISTICS	CLASS	TYPE OF CHECK	QUANTUM OF CHECK		REFERENCE DOCUMENT	ACCEPTANCE NORMS	FORMAT OF RECORD		AGENCY			REMARKS
					M	C/ N			9	* D	M	C	N	
1.3	Castings	Freedom from defects	Major	Visual	Mnfr std.	-	Approved Data Sheet	Casting shall be free from any defects such as blow holes , surface blisters , cracks and cavities etc.	Inspection report		P/ V *	-	-	Refer note No. 1
1.4	Sheet metal forming and fabrication	Freedom from defects	Major	Visual	Mnfr std.	-	Approved Data Sheet	Sheet metal fabrication / forming etc should be as per manufacturer drgs.	Inspection report		P/ V *	-	-	Refer note No. 1
1.5	Pre-treatment and powder coating	Pre-treatment process checks, Powder Coating finish, thickness , uniformity of coating and adhesion	Major	Visual, chemical & mech	Mnfr std.	-	Mnfr standard , Approved Data Sheet	Nominal coating thickness 50 microns or more	Inspection report		P/ V *	-	-	Refer note No. 1
B. ACCEPTANCE TEST														

BHEL						BIDDER/ SUPPLIER		FOR CUSTOMER REVIEW & APPROVAL			
ENGINEERING			QUALITY			Sign & Date		Doc No:			
Prepared by:	Sign & Date	Name	Checked by:	Sign & Date	Name	Seal		Sign & Date	Name	Seal	
MEET SAGAR SINGH RAJPAL	09.07.2020			09.07.20	KUNAL GANDHI						
PRAVEEN DUTTA			Digitally signed by RITESH KUMAR JAISWAL								

Date: 2020.07.10 20:28:22 +05'30'

	MANUFACTURER/ BIDDER/ SUPPLIER NAME & ADDRESS		STANDARD QUALITY PLAN				SPEC. NO :		DATE:	
			CUSTOMER :				QP NO.:PE-QP-999-558-E001, R04		DATE: 23.06.2020	
			PROJECT:				PO NO.:		DATE:	
			ITEM: LIGHTING FIXTURES, LAMPS & MISC. ITEMS		SYSTEM:STATION LIGHTING SYSTEM		SECTION: II		SHEET 3 OF 10	

SL NO.	COMPONENT & OPERATIONS	CHARACTERISTICS	CLASS	TYPE OF CHECK	QUANTUM OF CHECK		REFERENCE DOCUMENT	ACCEPTANCE NORMS	FORMAT OF RECORD		AGENCY			REMARKS
1	2	3	4	5	6		7	8	9	*	**			
					M	C/ N				D	M	C	N	

CONVENTIONAL TYPE LIGHTING FIXTURES	a) VISUAL	MA	VISUAL	IS 10322 (PART5 SEC1)	IS 10322 (PART 5 SEC1)	IS 10322 / APPD GA	IS 10322 / APPD GA	Inspection report	√	P	W	W		
	b) IR (Dry)	CR	Electrical	IS 10322	IS 10322	IS 10322	IS 10322	Inspection report	√	P	W	W		
	c) HIGH VOLTAGE	CR	Electrical	IS 10322	IS 10322	IS 10322	IS 10322	Inspection report	√	P	W	W		
	d) DUST PROOF	CR	Electrical	IS 10322	IS 10322	IS 10322	IS 10322	Inspection report	√	P	W	W		
	e) PHOTOMETRIC	CR	Electrical	IS-10322	*	IS 10322	IS 10322	Inspection report	√	P	W	W	*: One no.Luminaire of each type to be witnessed by BHEL/ Customer	
	2. ROUTINE TEST													
	a) VISUAL	MA	Visual	IS 10322 (PART5 SEC1)	IS 10322 (PART 5 SEC1)	IS 10322 / APPD GA	IS 10322 / APPD GA	Test cert	√	P	V	-		
	b) IR (Dry)	CR	Electrical	IS 10322	IS 10322	IS 10322	IS 10322	Test cert	√	P	V	-		
	c) HIGH VOLTAGE	CR	Electrical	IS 10322	IS 10322	IS 10322	IS 10322	Test cert	√	P	V	-		

KUNAL
09.07.20 GANDHI

BHEL					BIDDER/ SUPPLIER		FOR CUSTOMER REVIEW & APPROVAL			
ENGINEERING			QUALITY		Sign & Date		Doc No:			
Prepared by:	Sign & Date	Name	Checked by:	Sign & Date	Name	Seal	Sign & Date	Name	Seal	
MEET SAGAR SINGH RAJPAL	09.07.2020			09.07.20	KUNAL GANDHI					
PRAVEEN DUTTA			Digitally signed by:		RITESH KUMAR JAISWAL					

Date: 2020.07.10 20:28:57 +05'30'

	MANUFACTURER/ BIDDER/ SUPPLIER NAME & ADDRESS		STANDARD QUALITY PLAN					SPEC. NO :			DATE:	
	CUSTOMER :		PROJECT:					QP NO.:PE-QP-999-558-E001, R04			DATE: 23.06.2020	
	ITEM: LIGHTING FIXTURES, LAMPS & MISC. ITEMS		SYSTEM:STATION LIGHTING SYSTEM			SECTION: II			SHEET 4 OF 10			
	SL NO.	COMPONENT & OPERATIONS	CHARACTERIST ICS	CLASS	TYPE OF CHECK	QUANTUM OF CHECK	REFERENCE DOCUMENT	ACCEPTAN CE NORMS	FORMAT OF RECORD	AGENCY	REMARKS	
1	2	3	4	5	6	7	8	9	* D	** M C N		
					M C/ N							

2.0 LED TYPE LIGHTING FIXTURES

A	Bought out items / in-process checks													
1.1	LED chip	LED chip efficacy	Major	Visual	Mnfr. Std.	-	LM 80 report	Appd Data Sheet	LM 80 report	√	P/V	V	V	At the time of final Inspection
		LED chip CRI & CCT	Major	Visual	Mnfr. Std.	-	LM 80 report	Appd Data Sheet	LM 80 report	√	P/V	V	V	At the time of final Inspection
		Reported TM21 (L80) lifetime of LED chip	Major	Visual	Mnfr. Std.	-	LM 80 report	Appd Data Sheet	LM 80 report	√	P/V	V	V	At the time of final Inspection
1.2	LED Driver	Compatibility with LED module / chip, controls & protection features	Major	Visual	Mnfr. Std.	-	Appd Data Sheet	Appd Data Sheet	Certificate of Compliance	√	P/V	V	V	Certificate of Compliance by LED driver manufacturer / lighting fixture supplier that driver meets all specifications requirement
		THD & pf check	Major	Electrical	Mnfr. Std.	-	Appd Data Sheet	THD <10% and pf >=0.9	Inspection report	√	P/V*	-	-	Refer note No. 1

BHEL						BIDDER/ SUPPLIER		FOR CUSTOMER REVIEW & APPROVAL			
ENGINEERING			QUALITY			Sign & Date		Doc No:			
Prepared by:	Sign & Date	Name	Checked by:	Sign & Date	Name	Seal		Sign & Date	Name	Seal	
Prepared by:	09.07.2020	MEET SAGAR SINGH RAJPAL	Checked by:	09.07.20	KUNAL GANDHI						
Reviewed by:		PRAVEEN DUTTA	Reviewed by:	Digitally signed by RITESH KUMAR JAISWA							

Date: 2020.07.10 20:29:34 +05'30'

SL NO.		COMPONENT & OPERATIONS	CHARACTERIST ICS	CLASS	TYPE OF CHECK	QUANTUM OF CHECK		REFERENCE DOCUMENT	ACCEPTAN CE NORMS	FORMAT OF RECORD	AGENCY			REMARKS
1		2	3	4	5	6		7	8	9	*	**		
						M	C/ N				D	M	C	N
1.3	Castings	Freedom from defects	Major	Visual	Mnfr. Std.	-	Mnfr. Std.	Mnfr. Std.	Inspection report		P/V*	-	-	Refer note No. 1
1.4	Sheet metal forming and fabrication	Freedom from defects	Major	Visual	Mnfr. Std.	-	Mnfr. Std.	Mnfr. Std.	Inspection report		P/V*	-	-	Refer note No. 1
1.5	Pre-treatment and powder coating	Pre-treatment process checks, Powder Coating finish, thickness, uniformity of coating and adhesion	Major	Visual, chemical & mech	Mnfr. Std.	-	Mnfr. Std.	Nominal coating thickness 50 microns or more	Inspection report	√	P/V*	V	V	Refer note No. 1

BHEL					
ENGINEERING			QUALITY		
Prepared by:	Sign & Date	Name	Checked by:	Sign & Date	Name
	09.07.2020	MEET SAGAR SINGH RAJPAL		09.07.20	KUNAL GANDHI
Reviewed by:		PRAVEEN DUTTA	Reviewed by:	Digitally signed by	RITESH KUMAR JAISWAL

BIDDER/ SUPPLIER	
Sign & Date	Seal

FOR CUSTOMER REVIEW & APPROVAL			
Doc No:	Sign & Date	Name	Seal
Reviewed by:			
Approved by:			

Date: 2020.07.10 20:30:04 +05'30'

	MANUFACTURER/ BIDDER/ SUPPLIER NAME & ADDRESS		STANDARD QUALITY PLAN				SPEC. NO :		DATE:	
			CUSTOMER :				QP NO.:PE-QP-999-558-E001, R04		DATE: 23.06.2020	
			PROJECT:				PO NO.:		DATE:	
			ITEM: LIGHTING FIXTURES, LAMPS & MISC. ITEMS		SYSTEM:STATION LIGHTING SYSTEM		SECTION: II		SHEET 6 OF 10	

SL NO.	COMPONENT & OPERATIONS	CHARACTERIST ICS	CLASS	TYPE OF CHECK	QUANTUM OF CHECK		REFERENCE DOCUMENT	ACCEPTAN CE NORMS	FORMAT OF RECORD		AGENCY			REMARKS
1	2	3	4	5	6		7	8	9	*	**			
					M	C/ N				D	M	C	N	

B Acceptance Tests on LED Lighting fixtures														
1	LED Lighting fixture	Details of lot offered and Certificate of Compliance that lighting fixture supplier has inspected the offered lot as per their own standard.	Major	Visual	-	-	Lighting fixtures supplier to submit the details of lot offered for inspection (Type of lighting fixtures, their batch number, sub-vendor , name, quantity)	-	List	√	P	V	V	The list may be used for sample selection.
2		LED chip make	Major	Visual	-	-	Accepted type test reports (LM80/LM79) report	Certificate of compliance	Certificate of compliance	√	V	V	V	
3		Constructional features including: Internal writing , terminal block, earthing terminal, safety chain (if applicable)	Major	Visual	1 Sample per type	1 Sample per type	Approved data sheet/drg.	Approved data sheet/drg.	Inspection report	√	P	W	W	
4		Resistance to moisture test in	Major	Mechanical	1 Sample	1 Sample	IS 10322 / Approved data	Approved data sheet	Inspection report	√	P	W	W	

BHEL						BIDDER/ SUPPLIER		FOR CUSTOMER REVIEW & APPROVAL			
ENGINEERING			QUALITY			Sign & Date		Doc No:			
Prepared by:	Sign & Date	Name	Checked by:	Sign & Date	Name	Seal		Sign & Date	Name	Seal	
MEET SAGAR SINGH RAJPAL	09.07.2020		KUNAL GANDHI	09.07.20							
PRAVEEN DUTTA			Digitally signed by RITESH KUMAR JAISWAL								

Date: 2020.07.10 20:30:34 +05'30'

	MANUFACTURER/ BIDDER/ SUPPLIER NAME & ADDRESS	STANDARD QUALITY PLAN				SPEC. NO :		DATE:	
		CUSTOMER :				QP NO.:PE-QP-999-558-E001, R04		DATE: 23.06.2020	
		PROJECT:				PO NO.:		DATE:	
		ITEM: LIGHTING FIXTURES, LAMPS & MISC. ITEMS		SYSTEM:STATION LIGHTING SYSTEM		SECTION: II		SHEET 7 OF 10	

SL NO.	COMPONENT & OPERATIONS	CHARACTERIST ICS	CLASS	TYPE OF CHECK	QUANTUM OF CHECK		REFERENCE DOCUMENT	ACCEPTAN CE NORMS	FORMAT OF RECORD		AGENCY			REMARKS
					M	C/ N			9	* D	M	C	N	
		case of lighting fixtures having IP X4 and above rating.			e per type	e per type	sheet/drg							
5		Resistance to dust (applicable if IP5X and above)	Major	Optical	Mnfr. Std.	-	IS 10322 / Approved data sheet/drg.	Approved data sheet/drg	Certificate of compliance	√	P/ V *	V	V	Refer note No. 1
6		Photometry check	Major	Optical	Mnfr. Std.	-	LM79, IS 16106, IS 16107	Certificate of compliance for the batch: that offered lighting fixture LOR and lighting fixtures efficacy is not be less than 90% (refer IS 16107) with reference to type test reports.	Certificate of compliance	√	P/ V *	V	V	Refer note No. 1
7		Dimensions	Major	Visual	1 Sample per type	1 Sample per type	Approved data sheet/drg.	Approved data sheet/drg.	Inspection report	√	P	W	W	
8		LED driver: THD and pf check	Major	Visual	1 Sampl	1 Sampl	Approved data sheet	THD<10% and pf >= 0.9	Certificate of	√	P	W	W	At lighting fixtures supplier test lab.

BHEL					BIDDER/ SUPPLIER		FOR CUSTOMER REVIEW & APPROVAL			
ENGINEERING			QUALITY		Sign & Date		Doc No:			
Prepared by:	Sign & Date	Name	Checked by:	Sign & Date	Name	Seal		Sign & Date	Name	Seal
MEET SAGAR SINGH RAJPAL	09.07.2020			09.07.20	KUNAL GANDHI					
PRAVEEN DUTTA			Digitally signed by		RITESH KUMAR JAISWAL					

Date: 2020.07.10 20:31:04 +05'30'

	MANUFACTURER/ BIDDER/ SUPPLIER NAME & ADDRESS	STANDARD QUALITY PLAN					SPEC. NO :		DATE:	
		CUSTOMER :					QP NO.:PE-QP-999-558-E001, R04		DATE: 23.06.2020	
		PROJECT:					PO NO.:		DATE:	
		ITEM: LIGHTING FIXTURES, LAMPS & MISC. ITEMS			SYSTEM:STATION LIGHTING SYSTEM		SECTION: II		SHEET 8 OF 10	

SL NO.	COMPONENT & OPERATIONS	CHARACTERISTICS	CLASS	TYPE OF CHECK	QUANTUM OF CHECK		REFERENCE DOCUMENT	ACCEPTANCE NORMS	FORMAT OF RECORD	AGENCY			REMARKS
					M	C/ N					*	**	
1	2	3	4	5	6	7	8	9	D	M	C	N	
					e per type	e per type			compliance				
9	LED driver: Precision current control check	Major	Electrical	1 Sample per type	1 Sample per type	Approved data sheet	Approved data sheet	Inspection report	√	P	W	W	
10	LED driver: Open circuit protection simulation check	Major	Electrical	1 Sample per type	1 Sample per type	Approved data sheet	Approved data sheet	Inspection report	√	P	W	W	
11	LED driver: short circuit protection simulation check	Major	Electrical	1 Sample per type	1 Sample per type	Approved data sheet	Approved data sheet	Inspection report	√	P	W	W	
12	LED driver: over temperature protection simulation check	Major	Electrical	1 Sample per type	1 Sample per type	Approved data sheet	Approved data sheet	Inspection report	√	P	W	W	
13	LED driver: overload protection simulation check	Major	Electrical	1 Sample per type	1 Sample per type	Approved data sheet	Approved data sheet	Inspection report	√	P	W	W	
14	LED driver: surge protection compliance check	Major	Electrical	-	-	Approved data sheet	Certificate of compliance that surge protection is provided.	Certificate of compliance	√	V	V	V	

BHEL					BIDDER/ SUPPLIER		FOR CUSTOMER REVIEW & APPROVAL			
ENGINEERING			QUALITY		Sign & Date		Doc No:			
Prepared by:	Sign & Date	Name	Checked by:	Sign & Date	Name	Seal		Sign & Date	Name	Seal
by:	09.07.2020	MEET SAGAR SINGH RAJPAL	by:	09.07.20	KUNAL GANDHI			Reviewed by:		
Reviewed by:		PRAVEEN DUTTA	Reviewed by:	Digitally signed by	RITESH KUMAR JAISWAL			Approved by:		

	MANUFACTURER/ BIDDER/ SUPPLIER NAME & ADDRESS		STANDARD QUALITY PLAN					SPEC. NO :		DATE:			
			CUSTOMER :					QP NO.:PE-QP-999-558-E001, R04		DATE: 23.06.2020			
			PROJECT:					PO NO.:		DATE:			
			ITEM: LIGHTING FIXTURES, LAMPS & MISC. ITEMS			SYSTEM:STATION LIGHTING SYSTEM		SECTION: II		SHEET 9 OF 10			
SL NO.	COMPONENT & OPERATIONS	CHARACTERIST ICS	CLASS	TYPE OF CHECK	QUANTUM OF CHECK		REFERENCE DOCUMENT	ACCEPTAN CE NORMS	FORMAT OF RECORD		AGENCY	REMARKS	
1	2	3	4	5	6		7	8	9	*	**		
					M	C/ N				D	M	C	N

3.0 JUNCTION BOXES & RECEPTACLES

A	Acceptance Tests													
1	Acceptance Tests	Dimensions	Major	MEASURE MENT	100%	-	Appd Drawing	Appd Drawing	Inspection report		P	V	-	Components shall be of approved Make
2		Paint Shade/ Thickness	Major	VISUAL/ME AS.	SAMP LE	-	Appd Drawing	Appd Drawing	Inspection report		P	V	-	At the time of final Inspection
3		HV/ IR	Major	ELECT.TES TS	100%	-	2KV AC FOR 1 MINUTE	2KV AC FOR 1 MINUTE	Inspection report		P	V	-	
4		Degree Of Protection	Major	TEST	1/SIZE	-	IS:2147	IS:2147	TEST CERT.	√	P	V	V	
5		Special tests if any, explosion proof etc.	Major	TEST	1/SIZE	-	IS:2148	IS:2148	TEST CERT.	√	P	V	V	
6		Operation Check	Major	TEST	10%	-	Appd Drawing	Appd Drawing	Inspection report		P	V	-	
7		Mechanical Interlock	Major	TEST	10%	-	Appd Drawing	Appd Drawing	Inspection report		P	V	-	
4.0 PACKING														
	PACKING	Soundness of Packing against transit damage	Major	Visual	100%	100%	BHEL approved document	BHEL approved document	Inspection report	√	P	W	-	

BHEL						BIDDER/ SUPPLIER		FOR CUSTOMER REVIEW & APPROVAL			
ENGINEERING			QUALITY			Sign & Date		Doc No:			
Prepared by:	Sign & Date	Name	Checked by:	Sign & Date	Name	Seal		Sign & Date	Name	Seal	
MEET SAGAR SINGH RAJPAL	09.07.2020			09.07.20	KUNAL GANDHI						
PRAVEEN DUTTA			Digitally signed by RITESH KUMAR JAISWAL								

Date: 2020.07.10 20:32:09 +05'30'

	MANUFACTURER/ BIDDER/ SUPPLIER NAME & ADDRESS		STANDARD QUALITY PLAN					SPEC. NO :		DATE:			
								CUSTOMER :		QP NO.:PE-QP-999-558-E001, R04		DATE: 23.06.2020	
			PROJECT:		PO NO.:		DATE:						
			ITEM: LIGHTING FIXTURES, LAMPS & MISC. ITEMS		SYSTEM:STATION LIGHTING SYSTEM		SECTION: II		SHEET 10 OF 10				
SL NO.	COMPONENT & OPERATIONS	CHARACTERIST ICS	CLASS	TYPE OF CHECK	QUANTUM OF CHECK		REFERENCE DOCUMENT	ACCEPTAN CE NORMS	FORMAT OF RECORD		AGENCY	REMARKS	
1	2	3	4	5	6		7	8	9	* D	**		
					M	C/ N					M	C	

NOTES:

1. P/V*- means test will be performed either by lighting fixture supplier or their sub-vendor and verified by lighting fixture supplier.
2. Project specific QP shall be based on customer requirement. In case, any changes in QP commented by customer at contract stage shall be carried out by bidder without any implication to BHEL/ Customer.
3. For export jobs, BHEL technical specification for seaworthy packing for export jobs is to be followed.
4. Packing shall be suitable for storage at site in tropical climatic conditions.
5. Latest revision/ year of issue of all the standards (IS/ ASME/ IEC etc.) Indicated in QP shall be referred.
6. BHEL reserves the right for conducting repeat test if required.
7. Items like ceiling fans, emergency lighting unit, flexible conduit, 24V supply module, ladders, hume pipe, switchboxes, exit signs etc. Will be cleared based on COC (certificate of compliance).
8. After packing and prior to issue MDCC, photographs of items to be dispatched shall be sent to BHEL purchase group for review.

LEGENDS:

*Records, identified with "Tick"(√) shall be essentially included by supplier in QA Documentation,
 ** **M:** Supplier/ Manufacturer/ Sub-Supplier, **C:** Main supplier/ BHEL/ Third Party Inspection Agency, **N:** Customer,
P: Perform, **W:** Witness, **V:** Verification, as appropriate
MA: Major, **MI:** Minor, **CR:** Critical, **D:** Documentation

BHEL						BIDDER/ SUPPLIER		FOR CUSTOMER REVIEW & APPROVAL			
ENGINEERING			QUALITY			Sign & Date		Doc No:			
Prepared by:	Sign & Date	Name	Checked by:	Sign & Date	Name	Seal		Sign & Date	Name	Seal	
	09.07.2020	MEET SAGAR SINGH RAJPAL		09.07.20	KUNAL GANDHI						
Reviewed by:		PRAVEEN DUTTA	Reviewed by:	Digitally signed by JAISWAL	RITESH KUMAR						

Date: 2020.07.10 20:32:46 +05'30'

ANNEXURE-1A

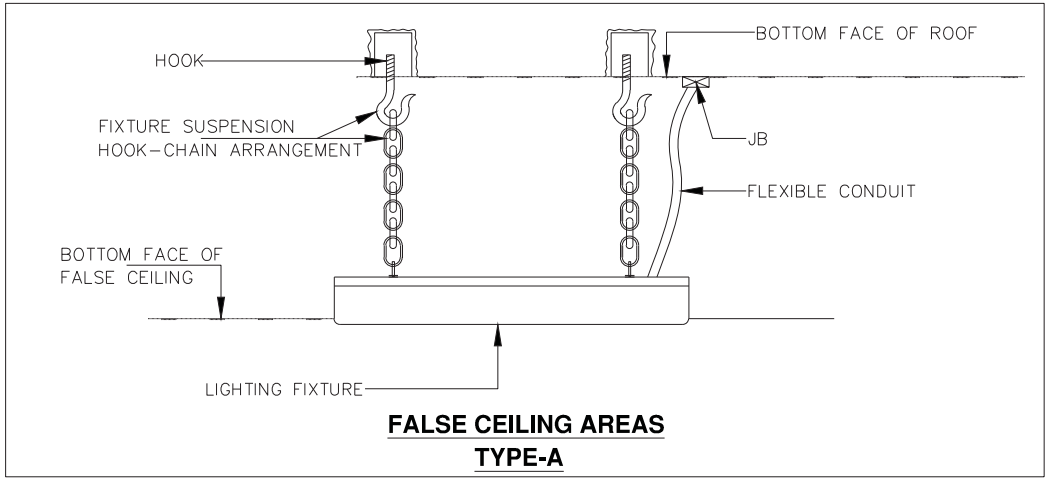

**FALSE CEILING AREAS
TYPE-A**

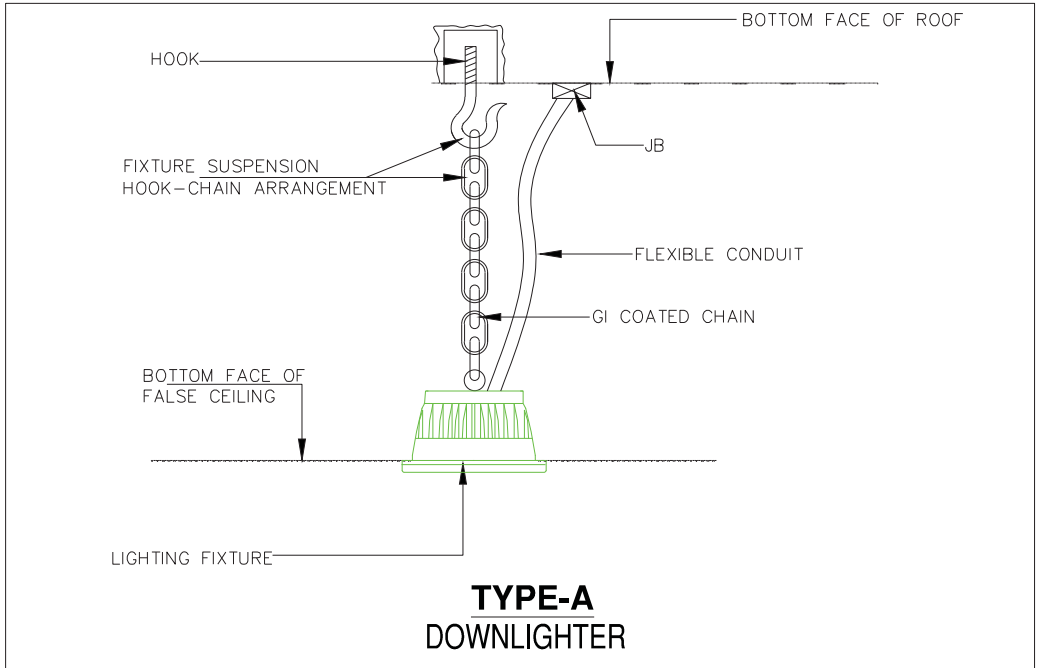

**TYPE-A
DOWNLIGHTER**

This is a typical mounting arrangement dwgs/ details for guidance only. Final Mounting arrangement dwg shall be made by the successful bidder during detailed Engineering. It is to be noted that GI Conduit 20mm Dia and Flexible PVC Coated Conduit, Structural Steel shall be provided by BHEL. Balance all other accessories clamps/ chains/ clips/ steel rope/ pins etc required for mounting as per typical mounting arrangement for their fixtures shall be part of fixtures only and shall be provided by the Bidders.

- In Lighting layout, Mounting arrangement also shown. If any Discrepancy found on both documents than Consult with Design incharge/Site Incharge.
- Quantity and Material shown in drawings are indicative only and may be change or vary as per site requirement.
- If any new type of mounting required at site than we can optimized or change the arrangement with prior inform to BHEL site incharge.
- All structural steel parts/supporting parts shall be hot dip galvanized as per BOQ/TS.

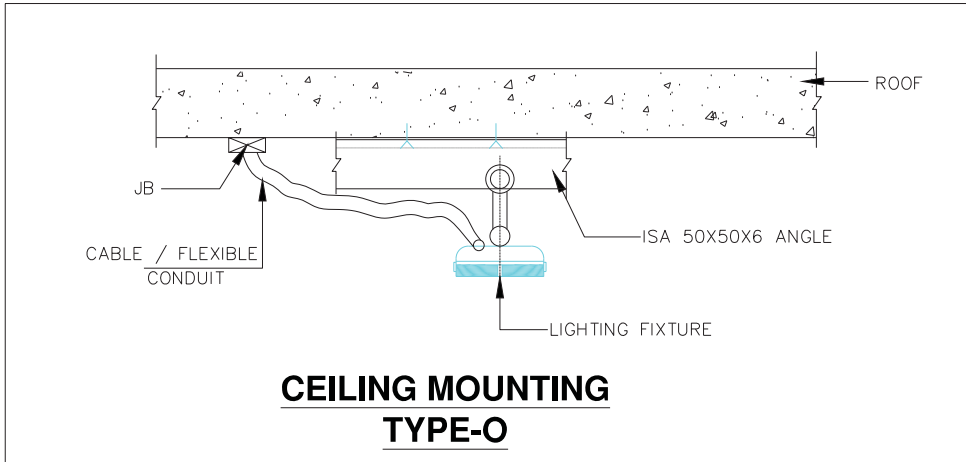

CEILING MOUNTING TYPE-O

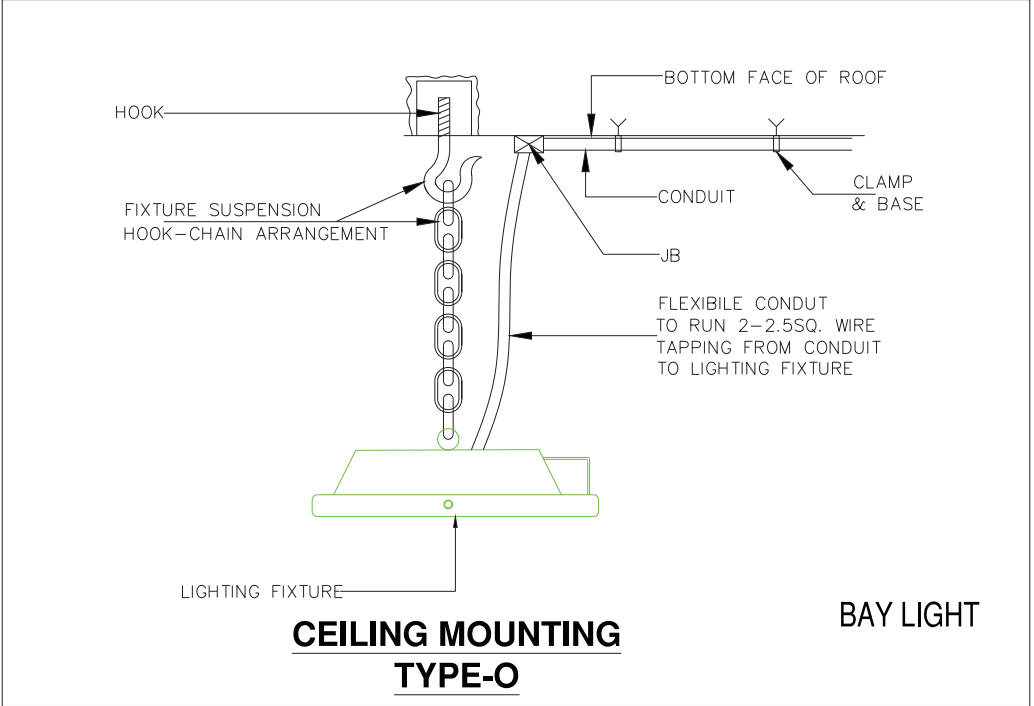

CEILING MOUNTING TYPE-O

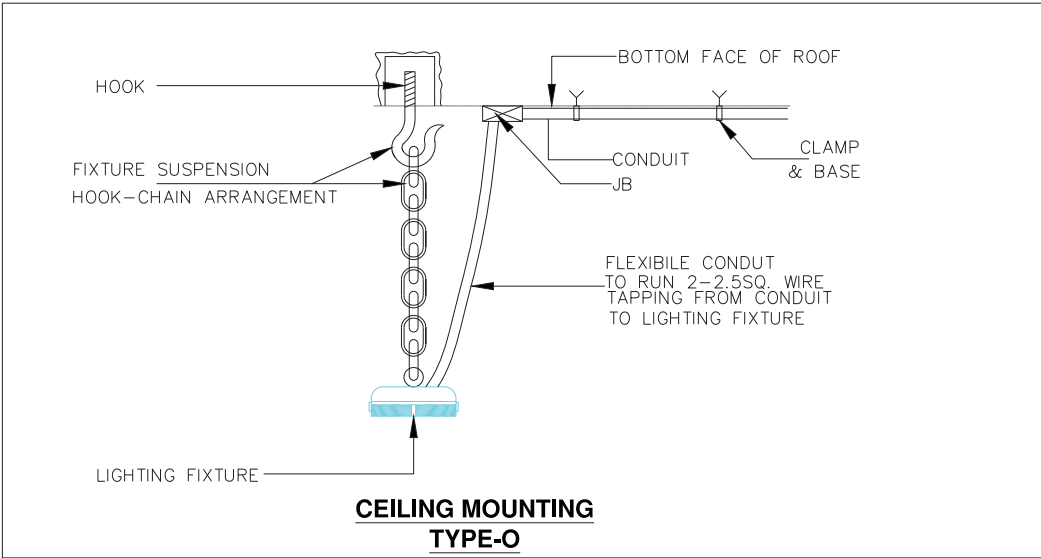

CEILING MOUNTING TYPE-O

- General Notes:
1. Mounting arrangement can be changed/ modified on site as per site requirements.
 2. In Lighting layout, Mounting arrangement also shown. If any Discrepancy found on both documents than Consult with Design incharge/Site Incharge.
 3. Quantity and Material shown in drawings are indicative only and may be change or vary as per site requirement.
 4. If any new type of mounting required at site than we can optimized or change the arrangement with prior inform to BHEL site incharge.
 5. All structural steel parts/supporting parts shall be hot dip galvanized as per BOQ/TS.

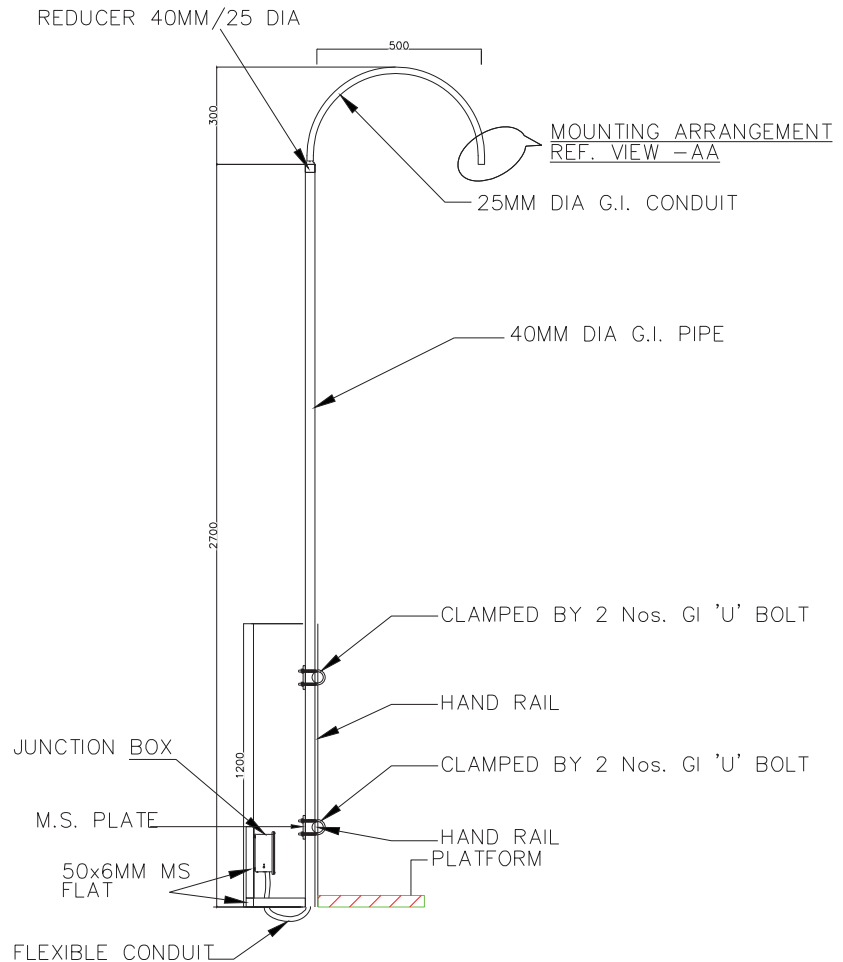

HAND RAIL MOUNTING TYPE-I

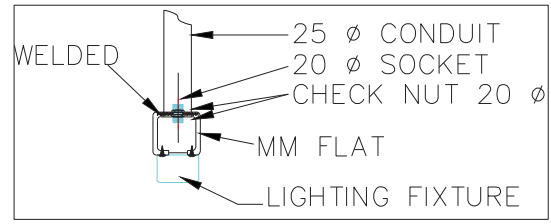
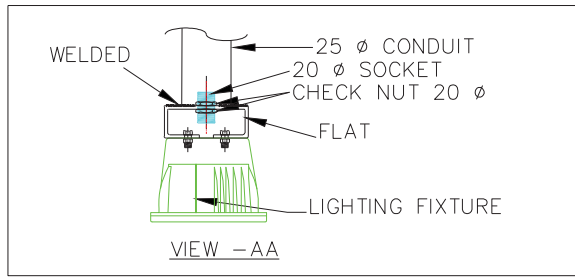
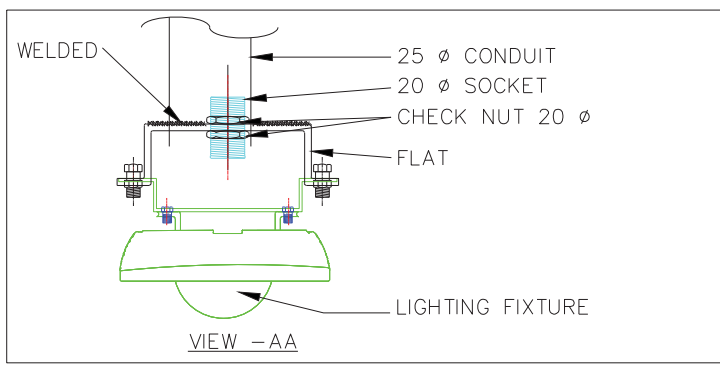

- General Notes:
1. Mounting arrangement can be changed/ modified on site as per site requirements.
 2. In Lighting layout, Mounting arrangement also shown. If any Discrepancy found on both documents than Consult with Design incharge/Site Incharge.
 3. Quantity and Material shown in drawings are indicative only and may be change or vary as per site requirement.
 4. If any new type of mounting required at site than we can optimized or change the arrangement with prior inform to BHEL site incharge.
 5. All structural steel parts/supporting parts shall be hot dip galvanized as per BOQ/TS.

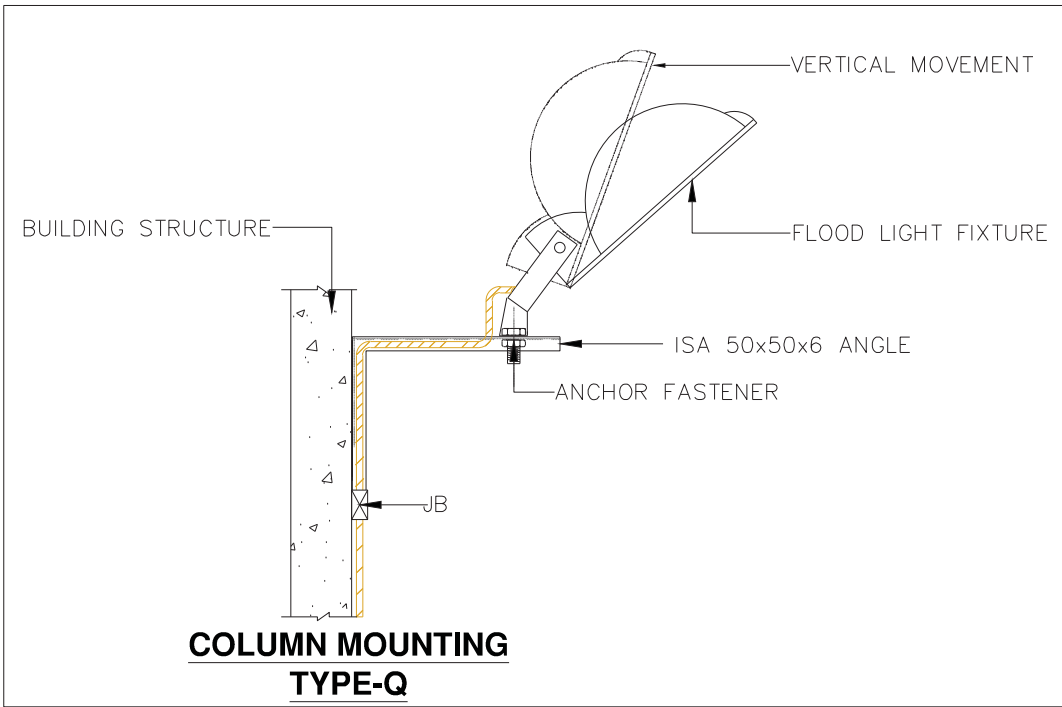
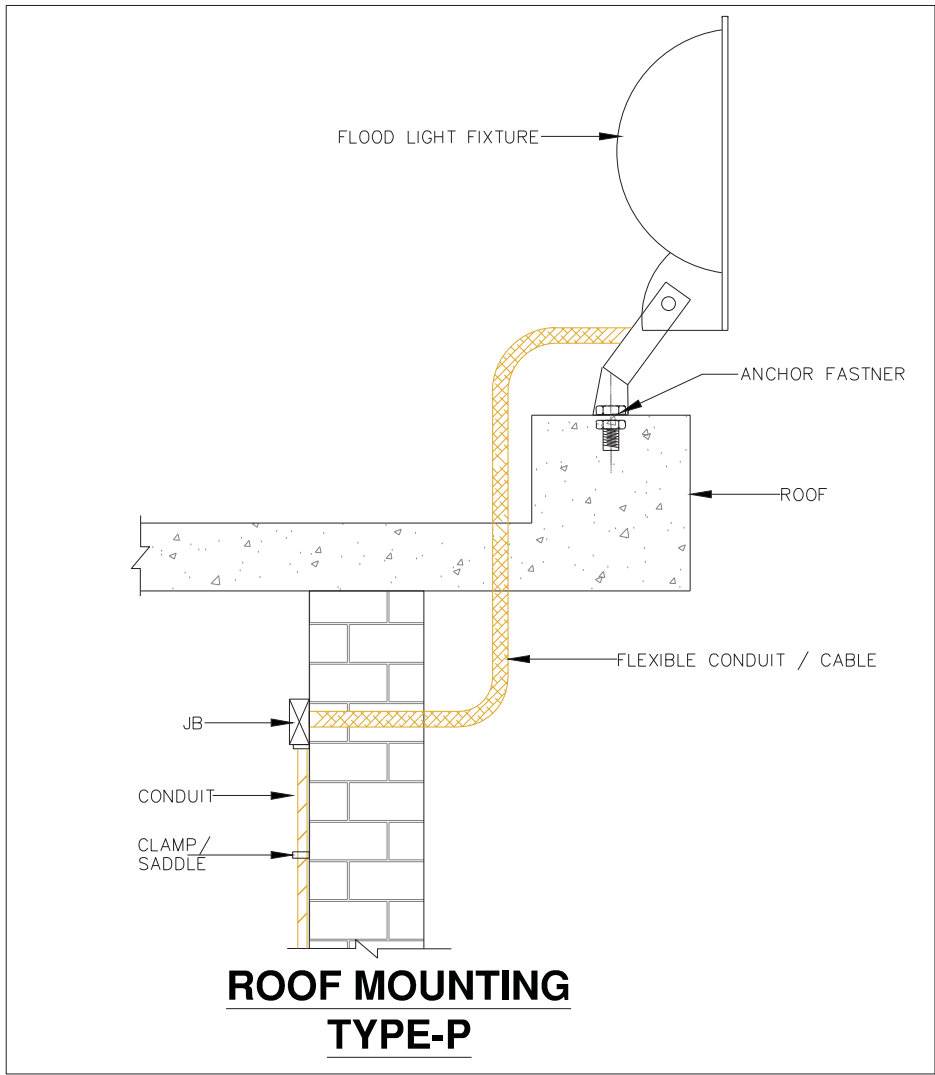

General Notes:

1. Mounting arrangement can be changed/ modified on site as per site requirements.
2. In Lighting layout, Mounting arrangement also shown. If any Discrepancy found on both documents than Consult with Design incharge/Site Incharge.
3. Quantity and Material shown in drawings are indicative only and may be change or vary as per site requirement.
4. If any new type of mounting required at site than we can optimized or change the arrangement with prior inform to BHEL site incharge.
5. All structural steel parts/supporting parts shall be hot dip galvanized as per BOQ/TS.

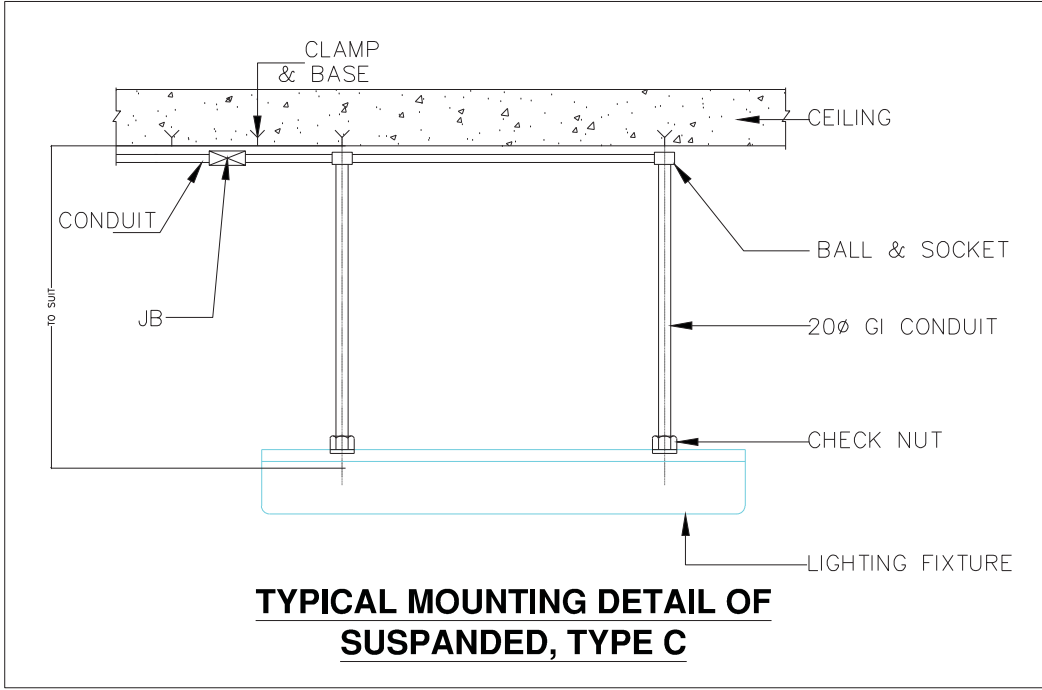
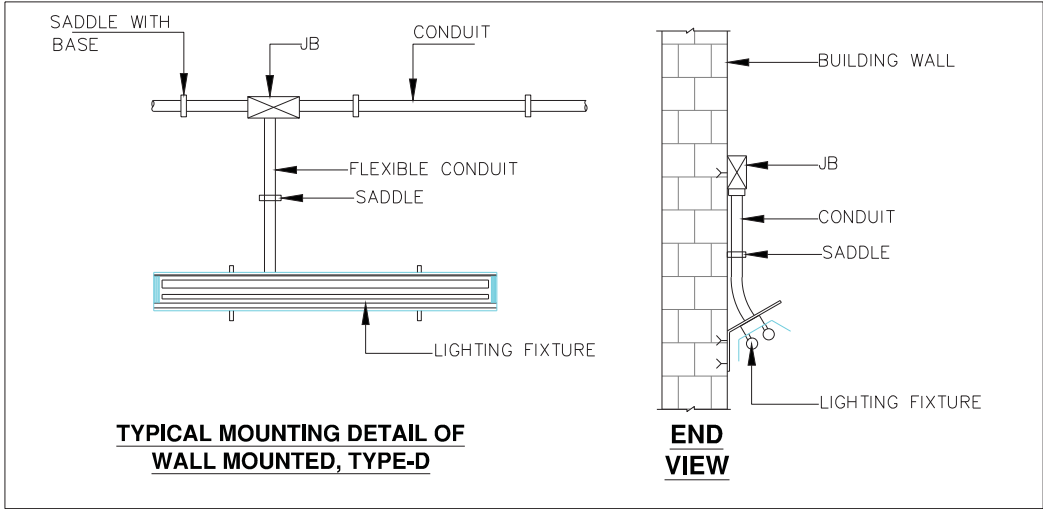

- General Notes:
1. Mounting arrangement can be changed/ modified on site as per site requirements.
 2. In Lighting layout, Mounting arrangement also shown. If any Descrepancy found on both documents than Consult with Design incharge/Site Incharge.
 3. Quantity and Material shown in drawings are indicative only and may be change or vary as per site requirement.
 4. If any new type of mounting required at site than we can optimized or change the arrangement with prior inform to BHEL site incharge.
 5. All structural steel parts/supporting parts shall be hot dip galvanized as per BOQ/TS.

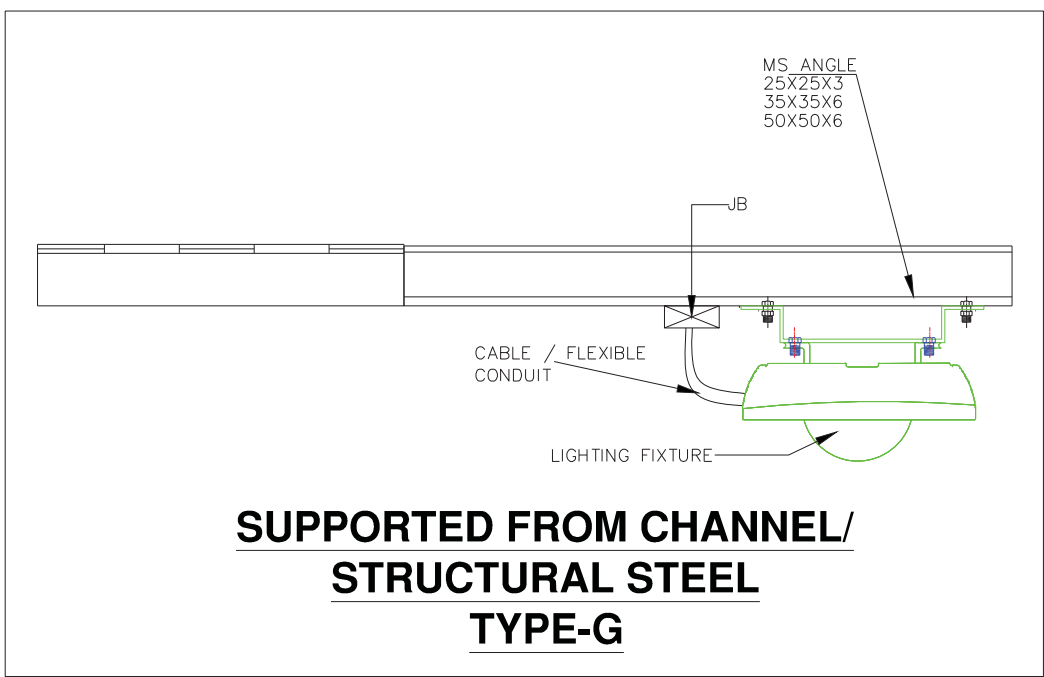
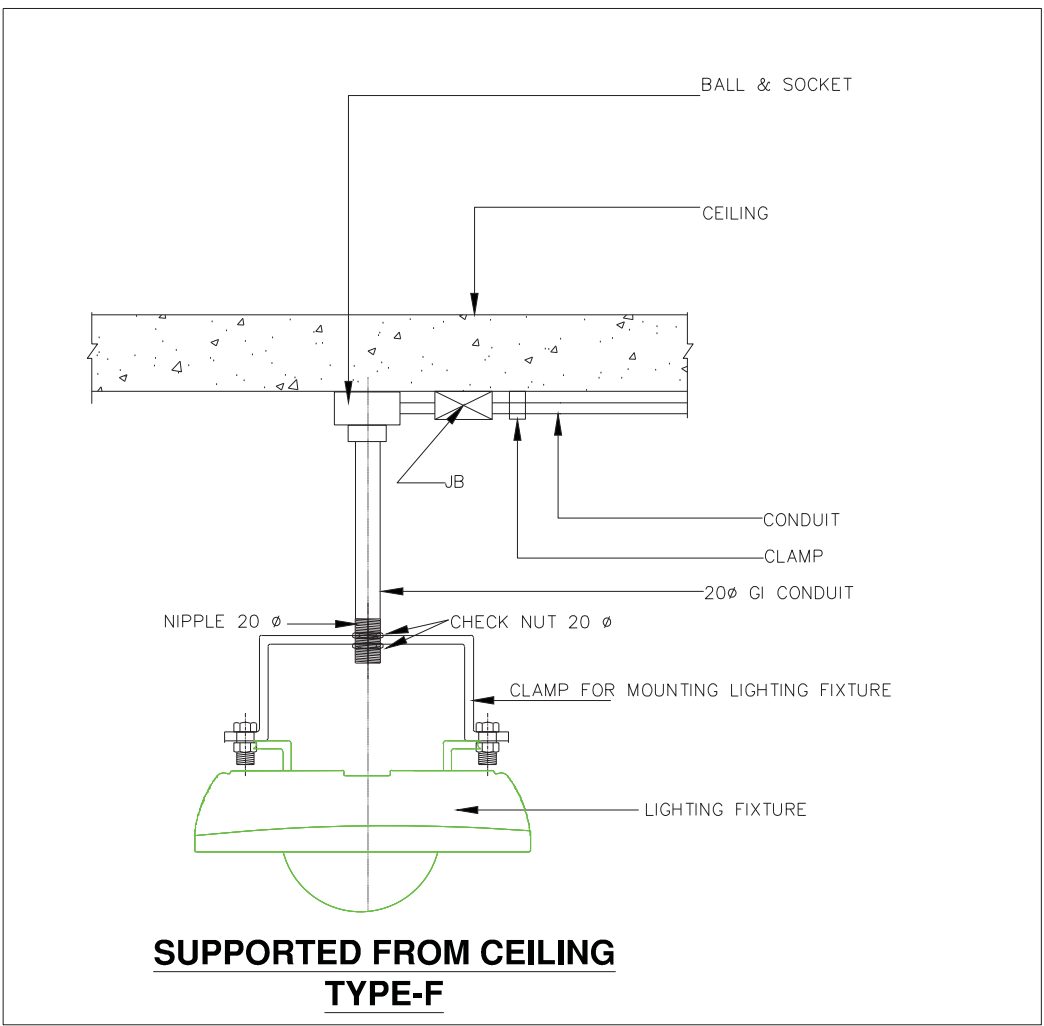

General Notes:

1. Mounting arrangement can be changed/ modified on site as per site requirements.
2. In Lighting layout, Mounting arrangement also shown. If any Discrepancy found on both documents than Consult with Design incharge/Site Incharge.
3. Quantity and Material shown in drawings are indicative only and may be change or vary as per site requirement.
4. If any new type of mounting required at site than we can optimized or change the arrangement with prior inform to BHEL site incharge.
5. All structural steel parts/supporting parts shall be hot dip galvanized as per BOQ/TS.

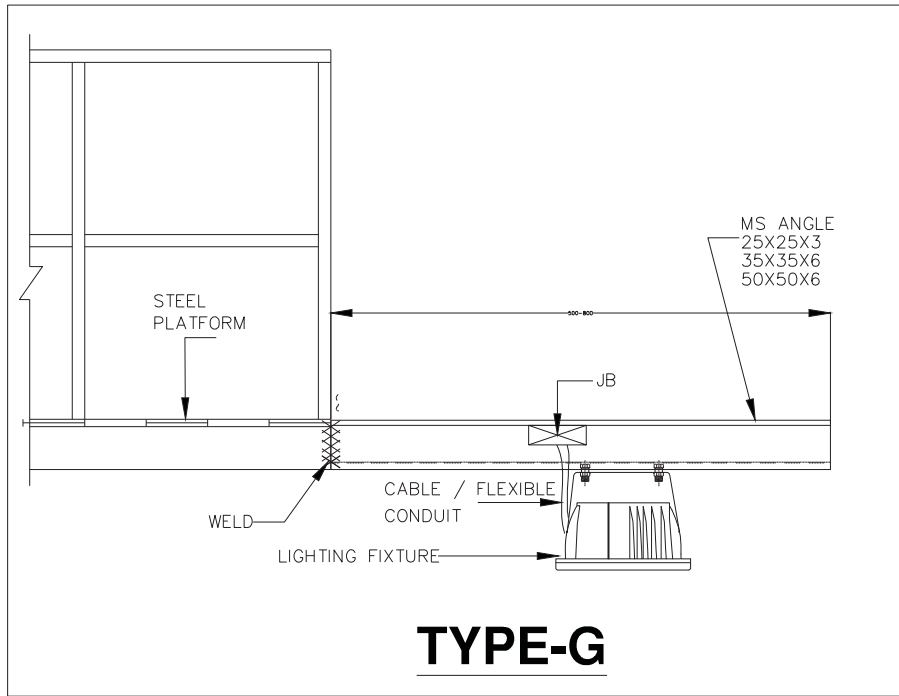

TYPE-G

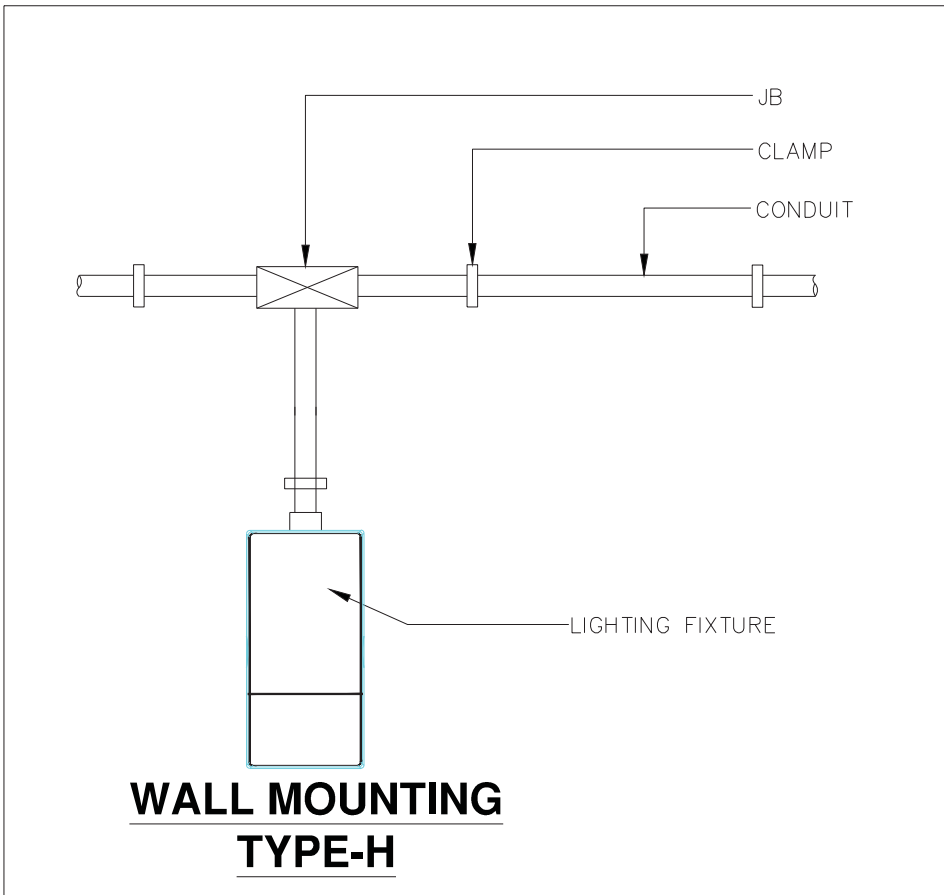

**WALL MOUNTING
TYPE-H**

General Notes:

1. Mounting arrangement can be changed/ modified on site as per site requirements.
2. In Lighting layout, Mounting arrangement also shown. If any Discrepancy found on both documents than Consult with Design incharge/Site Incharge.
3. Quantity and Material shown in drawings are indicative only and may be change or vary as per site requirement.
4. If any new type of mounting required at site than we can optimized or change the arrangement with prior inform to BHEL site incharge.
5. All structural steel parts/supporting parts shall be hot dip galvanized as per BOQ/TS.

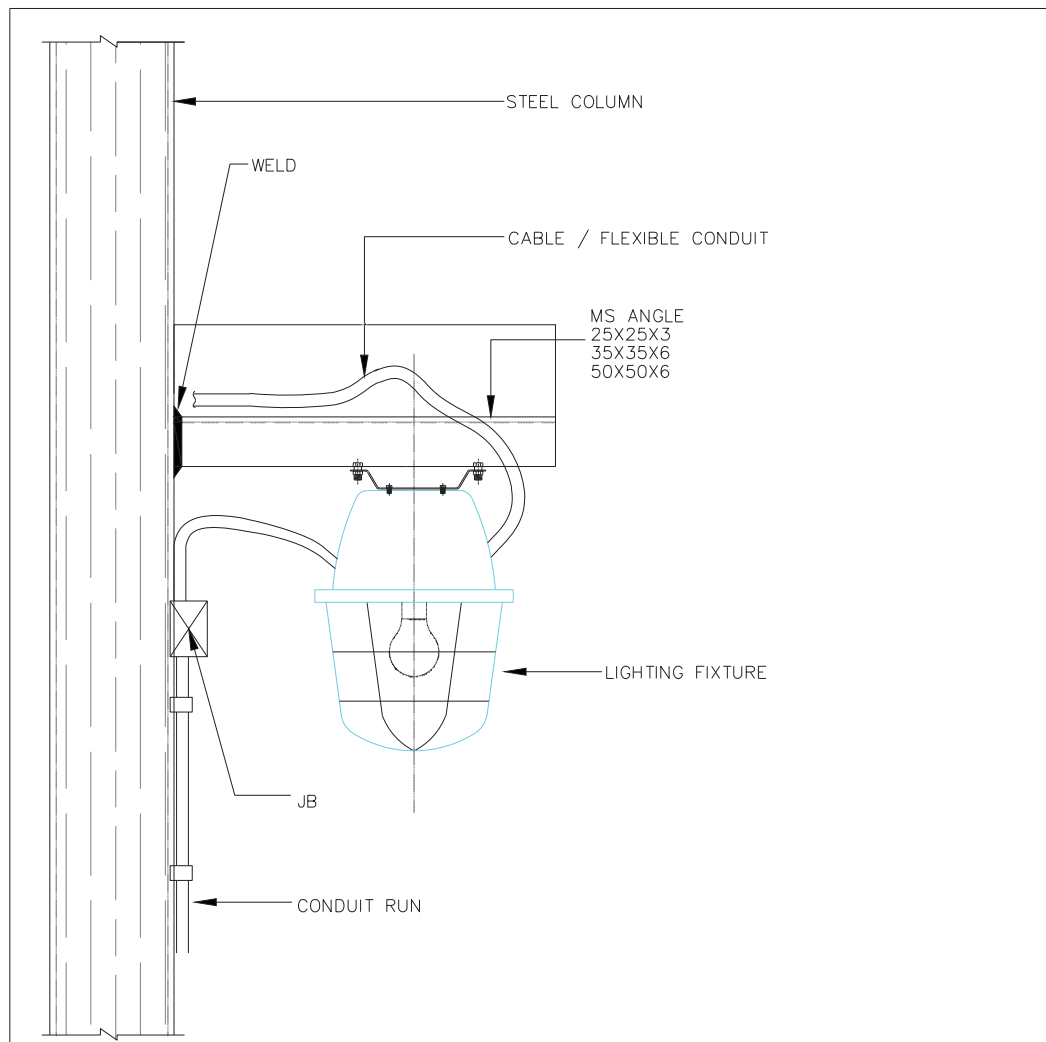

COLUMN MOUNTING
TYPE-M

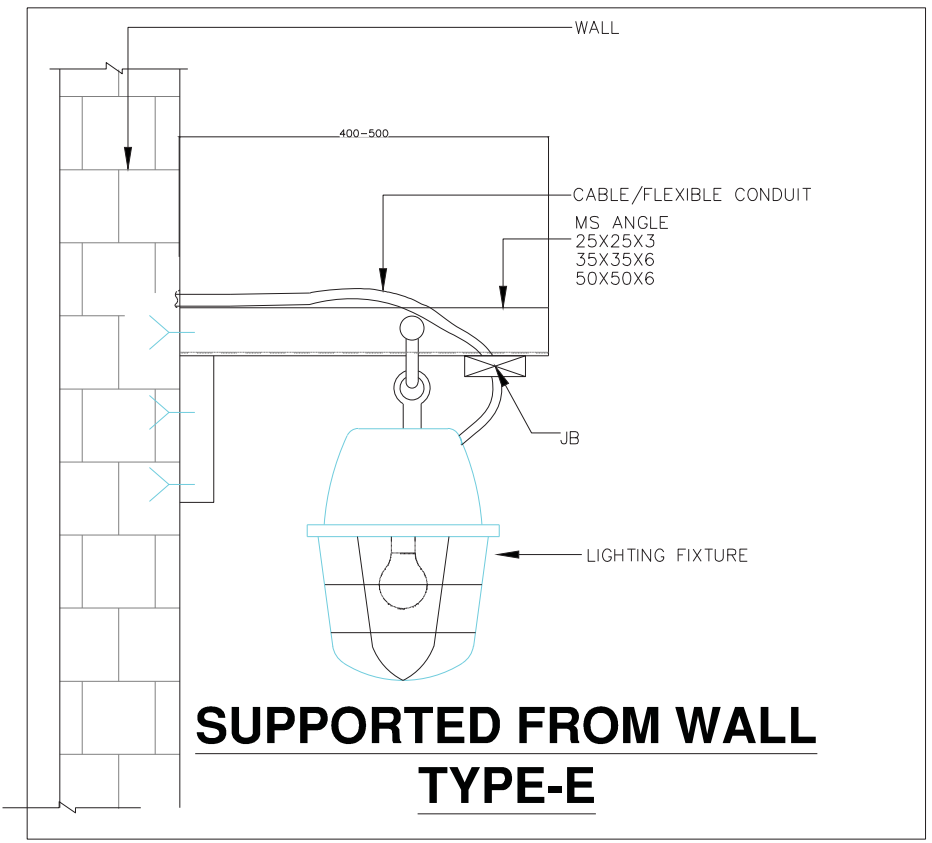

SUPPORTED FROM WALL
TYPE-E

General Notes:

1. Mounting arrangement can be changed/ modified on site as per site requirements.
2. In Lighting layout, Mounting arrangement also shown. If any Discrepancy found on both documents than Consult with Design incharge/Site Incharge.
3. Quantity and Material shown in drawings are indicative only and may be change or vary as per site requirement.
4. If any new type of mounting required at site than we can optimized or change the arrangement with prior inform to BHEL site incharge.
5. All structural steel parts/supporting parts shall be hot dip galvanized as per BOQ/TS.

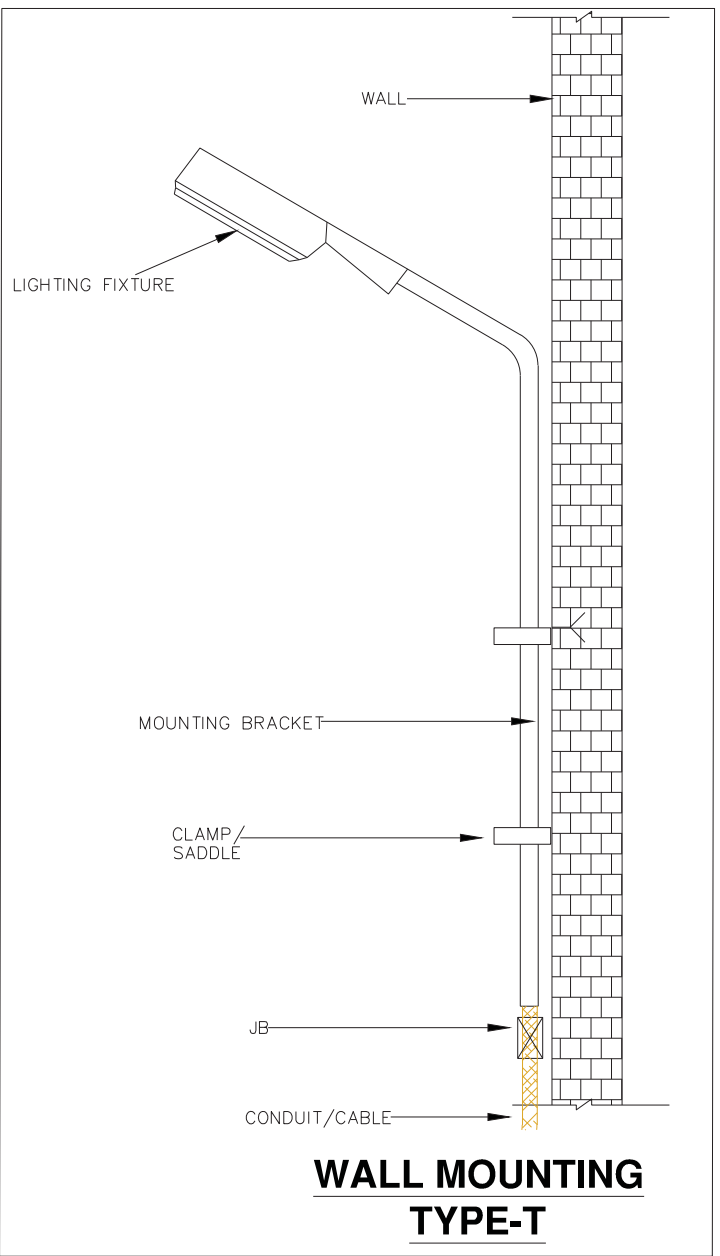

**WALL MOUNTING
TYPE-T**

General Notes:

1. Mounting arrangement can be changed/ modified on site as per site requirements.
2. In Lighting layout, Mounting arrangement also shown. If any Discrepancy found on both documents than Consult with Design incharge/Site Incharge.
3. Quantity and Material shown in drawings are indicative only and may be change or vary as per site requirement.
4. If any new type of mounting required at site than we can optimized or change the arrangement with prior inform to BHEL site incharge.
5. All structural steel parts/supporting parts shall be hot dip galvanized as per BQQ/TS.

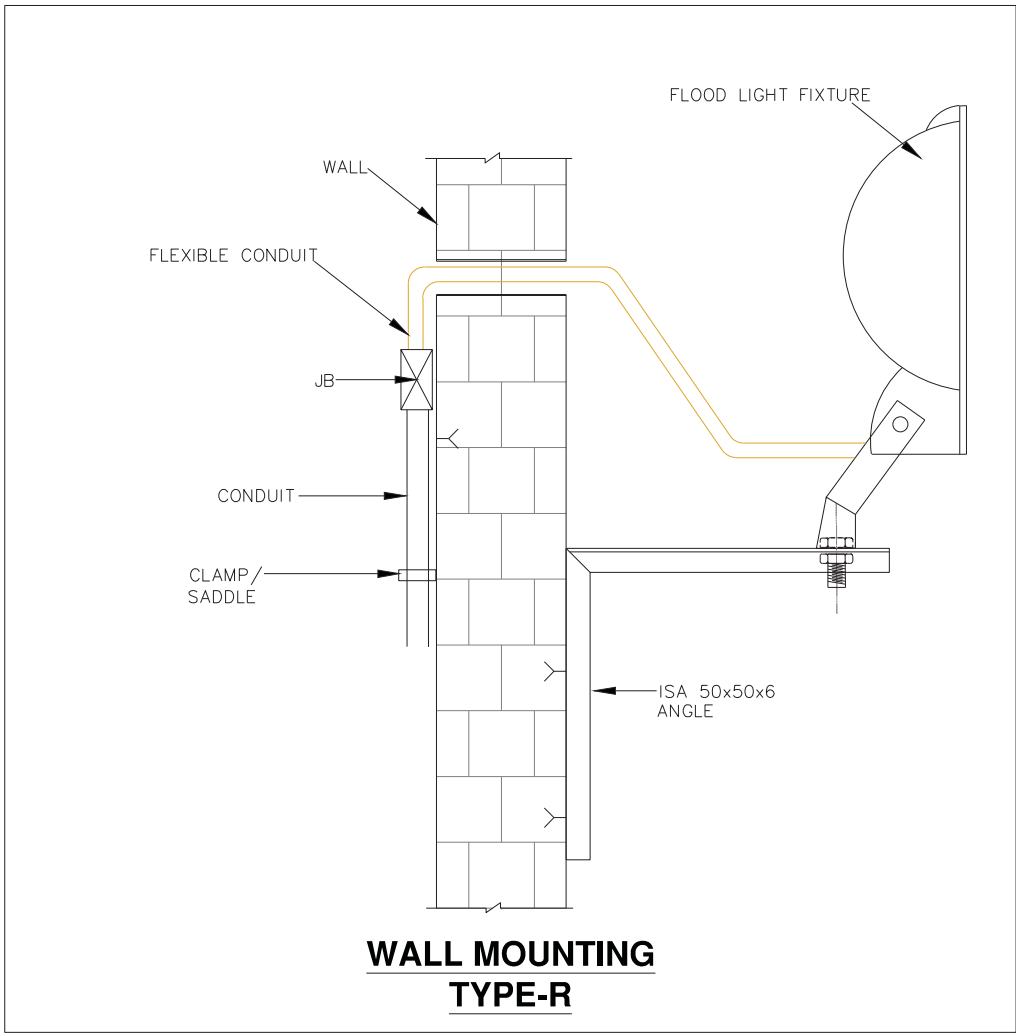

General Notes:

1. Mounting arrangement can be changed/ modified on site as per site requirements.
2. In Lighting layout, Mounting arrangement also shown. If any Discrepancy found on both documents than Consult with Design incharge/Site Incharge.
3. Quantity and Material shown in drawings are indicative only and may be change or vary as per site requirement.
4. If any new type of mounting required at site than we can optimized or change the arrangement with prior inform to BHEL site incharge.
5. All structural steel parts/supporting parts shall be hot dip galvanized as per BQQ/TS.