

PART – 1 CIVIL WORKS FOR EXTENSION OF NEW FABRICATION BAY AND MP SHOP IN  
FACTORY  
PART – 2 CONSTRUCTION OF FASTENER STORES INSIDE FACTORY

This tender document contains 126 pages



Bharat Heavy Electricals Limited  
Boiler Auxiliaries Plant,  
Ranipet –632 406

**NOTICE INVITING TENDERS**

1. Tender Notice Number : BAP:CF:17/2009-10 dated 12.09.2009
2. Name of work : Part 1 Civil works for extension of New Fabrication bay and Existing MP shop in Factory & Part 2 Construction of New Fastener stores inside Factory.
3. Completion Time : As per schedule A
4. Estimated Cost : Rs 105.59 Lakhs
5. Document cost : Rs. 500/-
6. Earnest Money Deposit : 2,00,000/-
7. Last Date & Time for receipt of Completed Tender. : Before 2.30 P.M. on 22.10.2009.
8. Date & Time of tender Opening:
  - Technical bid : At 2.30 P.M. on 22.10.2009.
9. Place of submission of Tender : **Office of Sr. DGM (Civil Projects & Services)  
BHEL, Ranipet Vellore Dist.  
Tamil Nadu. Pin 632 406.**

This tender document contains 126 pages including the following.

**Part I :-** Technical Bid from Page No.1 to 103 including General conditions of Contract, Special conditions of contract, drawings, Annexure A to G, Schedule A to D, etc  
**Part II :-** Commercial Bid from Page No.1 to 23 of Bill of Quantities.

**Tender should be submitted in a sealed cover consisting of two inner sealed covers such as i) Technical bid cover with requisite EMD & and all documentary evidence of meeting the qualifying requirements ii) Price bid cover (consisting of rate schedule only), super scribing the name of work, Tender Notice number , Due date of Opening.**

Tenders without **EMD shall be summarily rejected.**

**Note: The tenderer shall return the duly filled in tender document after affixing signature on all the pages of the Tender Documents.**

Issued to :

CONTRACTOR

ISSUING OFFICER 1



Bharat Heavy Electricals Limited  
Boiler Auxiliaries Plant,  
Ranipet –632 406

**1. Eligibility criteria:**

- i) Average annual financial turnover during the last 3 years ending 31st March 2009, should be at least 30% of the estimated cost.
- ii) Experience of having successfully completed similar works during the last 7 years as on 31.03.2009 for Government Departments, Government Undertakings **reputed private sectors** etc. should be any one of the followings:
  - a) Three similar completed works costing not less than the amount equal to **40%** of estimated cost.
  - b) Two similar completed works costing not less than the amount equal to **50%** of estimated cost.
  - c) One similar completed work costing not less than the amount equal to **80%** of estimated cost.



Bharat Heavy Electricals Limited  
Boiler Auxiliaries Plant,  
Ranipet –632 406

## INSTRUCTIONS TO TENDERERS

2. Sealed Tenders for the above said work is hereby invited from Contractors experienced in works of similar kind and magnitude.
3. Tenders should be addressed to Sr. DGM (Civil Factory), Bharat Heavy Electricals Limited, BAP, Ranipet 632 406, Vellore Dist. T.N. Fax 04172-241102 cell 9443389051 email [ccdurai@bhelrpt.co.in](mailto:ccdurai@bhelrpt.co.in) The full name and address of the tenderer, name of the work, Tender Notice No. and the date of opening should be indicated on the cover.
4. The local address of the Contractor, the name of the person to whom all the correspondence are to be addressed should be indicated with telephone number (both office & residence), FAX / e-mail address, mobile no. etc..
5. All entries in the tender documents should be in same ink. Erasures and over writing are not permitted. All cancellations and insertions should be duly signed by the tenderer concerned with proper indication of the name, designation and address of the person signing.
6. Tenderers shall fill in all the required particulars in the blank spaces provided for this purpose in the tender documents and also sign each and every page of the tender document including the drawings (wherever applicable) attached there to before submitting the tender.
7. Unit rates should be quoted in figures as well as in words in **Indian Currency only** – i.e., Rupees and Paise with reference to each item and for all the items shown in the attached schedule. The rates shall include all taxes and duties payable excluding Service Tax and including expenses towards PF and ESI contributions Amount of each item and the total on each sheet as also the grand total amount of the whole contract shall be filled in by the tenderers.
8. In the case the rate quoted in figures differ from those quoted in words, the lower of the rates will be taken as the tendered rate and shall be binding on the tenderers.
9. In quoting their rates, the tenderers are advised to take into account all factors including any **fluctuations** in market rates. No claim for enhanced rates will be entertained on this account after acceptance of the tender or during the currency of the contract.
10. **The rates to be quoted shall be firm** and shall inclusive of all applicable statutory levies arising from Central/State legislature and rules and regulations framed there under prevailing at the date 7 days prior to the last date of bid submission. Any variation in the existing statute or by introduction of new Tax and duties applicable to the above work will be to the account of BHEL at actuals against the documentary evidence.
11. (a) The rates quoted in the tender shall have the validity for a period of “THREE MONTHS” from the date of opening of tender.  
  
(b) Tenderer shall not increase their quoted rates, once the tender has been opened and during execution of the contract in case his tender is accepted.
12. **Quantities shown in the attached schedule are only tentative and approximate** and are liable for variation. The quantity variation within +20% from the schedule will be

CONTRACTOR

ISSUING OFFICER 3



Bharat Heavy Electricals Limited  
Boiler Auxiliaries Plant,  
Ranipet –632 406

paid at the quoted rates and the variation beyond +20% of the quantity will be paid deriving market rate at the discretion of BHEL.

13. Before quoting, the tenderers are advised to inspect the site of work and its environments and be well acquainted with the actual working and other prevailing conditions, position of materials and labour. They should be well versed with BHEL General Conditions of Contract, Instructions to tenderers, drawings wherever applicable and specifications and all other documents which form part of the agreement to be entered into subsequent to award of work. The tenderers shall specially note that it is the tenderer's responsibility to provide any item which is not specially mentioned in the specification or drawing, but which is necessary to complete the work.
14. Should a tenderer find discrepancies or omissions in the drawings wherever applicable / Specifications / Scope of work / Terms & Conditions attached to the tender documents or should be in doubt as to their meaning, he should at once address to the authority inviting the tender for clarifications.

Every endeavor is made to avoid any error which can materially affect the basis of the tender but the successful tenderer shall take upon himself to provide for the risk of any error which may be subsequently discovered and shall make no subsequent claim on account thereof.

15. In the event of tender being submitted by a firm, the tender must be signed separately and legibly by each partner or member of the firm or in their absence, by the person holding the power of Attorney on behalf of the firm concerned. In the latter case, a copy of the power of attorney duly attested by a Gazetted officer must accompany the tender.
16. Every tender must be accompanied by Demand Draft / deposit receipt for the amount mentioned as Earnest Money. This Earnest money will be refunded to the unsuccessful tenderers after finalization of the award of work. In the case of successful tenderer, the earnest money will be retained as part of the Security Deposit for satisfactory completion of the work.
17. **The Earnest Money Deposit shall be submitted along with Technical bid only and may be furnished in the form of Demand Draft drawn infavour of BHEL, RANIPET payable at Ranipet, Vellore Dist. T.N.**
18. Unless the Contractor whose tender is accepted signs the contract agreement within fifteen days (15 days) of the date of the order directing him to do so, the amount of Earnest Money already deposited by him may be forfeited and acceptance of his tender withdrawn.
19. If after opening of tenders, a tenderer revokes his tender or increases his earlier quoted rates or after acceptance of his tender does not commence the work in accordance with the instructions of Engineer-in-charge, the Earnest Money Deposited by him will be forfeited and acceptance of his tender withdrawn. If only a part of the work included in the tender had been awarded to the tenderer, the amount of Earnest Money to be forfeited will be based on the value of the contract so awarded.
20. BHARAT HEAVY ELECTRICALS LIMITED reserves the right to reject any or all the tenders received or accept any tender or part thereof without assigning any reason thereof. In the case of acceptance of a part of tender, the time for completion may also be reduced to the extent considered appropriate by the accepting authority.



Bharat Heavy Electricals Limited  
Boiler Auxiliaries Plant,  
Ranipet –632 406

21. Conditional and unsigned tenders, **tenders containing absurd rates and amounts**, tenders which are incomplete or otherwise considered defective, tenders which are not in accordance with the tender conditions laid down by the Accepting Officer and tenders not submitted in the prescribed forms are liable to be rejected.

**22. Documents to be submitted :**

The contractors who are not on the approved list of contractors of this organization must submit the following testimonials simultaneously with their tenders. These testimonials shall be signed by the person (s) issuing the same indicating their name, designation and full address.

- i) List of similar works executed by the company since last six months.
- ii) List of movable/immovable assets.
- iii) Name of Banker and copy of latest audited Profit & Loss Accounts and Balance sheet.
- iv) PAN number.
- v) Name of your Banker, address and Account Number.
- vi) Sales Tax & Service Tax Registration Certificates.
- vii) PF & ESI Registration Certificate.

23. The tenders should be accompanied by a list of contracts already held by the Contractor at the time of submitting the tender and giving the following particulars:

- a) Name of work, value and address.
- b) The balance work remaining to be done on the same.

**24. Tenders shall be received up to 14.30 Hours on the said due date and be opened on the same day at 14.30 Hours. Tenders received after 14.30 Hours would not be opened. The times indicated are Indian Standard Time (IST).**

If a Tenderer submits only one envelope / cover containing all the bids or combined bids e.g. techno-commercial bid & price bid together, otherwise the bid is liable for rejection. The decision to accept such bids shall be the sole discretion of BHEL, which may be done by BHEL after segregating the bids so received.

25. The contractor's responsibility under this contract shall commence from the date of receipt of the order or acceptance of Letter of Indent.

26. If a tenderer expires after the submission of the tender or after the acceptance of the tender, BHEL may, at their discretion, cancel such tender.

27. If a partner of the firm expires after the submission of the tender or after the acceptance of the tender, BHEL may cancel such tender at their discretion unless the firm retains its character/s.

28. BHARAT HEAVY ELECTRICALS LIMITED will not be bound by any power of Attorney granted by the tenderer or by changes in the composition of the firm made subsequent



Bharat Heavy Electricals Limited  
Boiler Auxiliaries Plant,  
Ranipet –632 406

to the execution of the contract. They may however, recognize such power of Attorney and changes after obtaining proper legal advice, the cost of which will be chargeable to the contractor concerned.

29. If the tenderer deliberately gives wrong information in his tender, BHEL reserves the right to reject such tender at any stage. Further the tenderer will be liable for any damage caused.
30. Words imparting the singular number shall be deemed to include the plural number and vice-versa where the context so requires.
31. The General and Special Conditions of Contract are complementary to each other and where they are in conflict, the special condition shall prevail.
32. The expenses for completing the stamping of the agreement shall be paid by the contractor.
33. Any covering letter and comments of the Contractor should be submitted in duplicate along with the offer.
34. Should a tenderer or a contractor on the list of approved contractors have a relative or in the case of firm or Company of contractors any of its share holder's relative is employed in a Gazetted Capacity in the Boiler Auxiliaries Plant, Bharat Heavy Electricals Limited, Ranipet 632 406, the authority inviting tenders shall be informed of this fact at the time of submission of the tender, failing which tender may be disqualified or if such a fact subsequently come to light, the relevant provisions of the General Conditions of Contract will apply.
35. These 'INSTRUCTIONS TO TENDERER'S & 'GENERAL CONDITIONS OF CONTRACT OF BHEL' shall be deemed to form an integral part of the contract agreement for the work to be entered into. In cases of variation between the two in any matter, the conditions in the 'THE INSTRUCTIONS TO TENDERERS' shall prevail. Extracts of some of the important clauses of BHEL G.C.C are enclosed (Annexure containing extracts of clauses 22 & 60 of BHEL GCC). The contractor has to obtain, at his cost, a copy of the BHEL GCC, scrutinize the same, and when submitting his tender, indicate his acceptance of BHEL GCC in the proforma enclosed at **Annexure B**.
36. The Contractor shall comply with the provision of Employees Provident Fund and Miscellaneous Provisions Act 1952 and rules, regulations and other orders issued there under. He, as an employer, shall be liable to pay employer's contribution/deductions towards PF under the PF Act in respect of all labour employed by him, for the execution of the contract in accordance with the provisions of the Employees Provident Funds and Miscellaneous Provisions Act, 1952 as amended from time to time. For this purpose he shall indicate the code number obtained from the Regional Provident Fund Commissioner or he should obtain a code number if he has not and produce the Photostat copy of the challan / receipt of monthly remittance of the contribution made by him to the PF Commissioner.
37. The Contractor should get himself registered with the E.S.I. Authorities as an independent Employer, obtain a separate code number and remit the dues in respect of the labour employed by him for the work and produce the Challans / Receipts of remittance of the ESI contributions due under the E.S.I. Act to the Company authorities. He shall also furnish such returns, as are due, under the Act, to be sent to the appropriate authorities through the Principal Employer.



**Bharat Heavy Electricals Limited**  
**Boiler Auxiliaries Plant,**  
**Ranipet –632 406**

If any action is brought in by P.F. Commissioner/ESI authorities on BHEL for the work done by the Contractor for his labourers regarding PF/ESI amount due, short remittances, non remittances etc., the Contractor shall defend the case on behalf of BHEL and/or reimburse BHEL the expenses so incurred.

If applicable, the Contractor shall apply and obtain license under Contract labour (R&A) Act 1970 and comply with the relevant provisions of this Act in respect of the labour employed by him for executing this contract. The Contractor shall furnish necessary returns to the authorities through the Principal Employer.

If applicable, the Contractor shall insure all his labourers and materials. Any claim by his employees for the damages shall be settled by the contractor even action is against BHEL or to reimburse the legal expenses incurred by BHEL.

38. Contractor shall produce necessary records, documents, explanation whenever he is called upon to do, by any Government Agencies like ESI, PF, VIGILANCE etc..

**39. TERMS OF PAYMENT:**

The Terms of payment will be as per the Terms & Conditions enclosed.

**40. EXTRA ITEMS / DEVIATED ITEMS:**

No extra items of work shall be carried out by the contractor other than those authorized to do so in writing by the Engineer. For any such items of work executed as per instructions of Engineer, the rates will be fixed on the basis indicated under clause 52 of BHEL GCC.

**41. SECURITY DEPOSIT:**

**a)** The rate of Security Deposit (SD) will be as below:

- Up to Rs. 10 lakhs: 10%
- Above 10 lakhs up to 50 lakhs: Rs. 1.lakh + 7.5% of amount exceeding Rs. 10 lakhs.
- Above 50 lakhs: Rs. 4 lakhs + 5% of the amount exceeding Rs. 50 lakhs.

The Security Deposit should be collected before start of the work from the Contractor.

**b)** The security deposit may be furnished in any one of the following forms:

- 1) Cash (as permissible under the Income Tax Act)
- 2) Pay order, Demand draft in favour of BHEL,
- 3) Local cheques of scheduled banks, subject to realization.
- 4) Securities available from Post offices such as National Savings Certificates, Kisan Vikas Patras etc. (Certificates should be held in the name of Contractor furnishing the security and duly pledged in favour of BHEL and discharged on the back).
- 5) Bank guarantee from Scheduled Banks / Public Financial Institutions as defined in the Companies Act. The Bank Guarantee format should have the approval of BHEL.



Bharat Heavy Electricals Limited  
Boiler Auxiliaries Plant,  
Ranipet –632 406

- 6) Fixed Deposit Receipt issued by Scheduled Banks / Public Financial Institutions as defined in the Companies Act. The FDR should be in the name of the contractor, A/c BHEL, duly discharged on the back.
- 7) Security Deposit can also be recovered at the rate of 10% from running bills. However in such cases at least 50% of the Security Deposit should be collected before start of the work and the balance 50% may be recovered from the running bills.
- 8) EMD of the successful tenderer can be converted and adjusted against the security deposit.
- 9) The security deposit shall not carry any interest.

(Note: Acceptance of security deposit against Serial No.4 & 6 above will be subject to hypothecation or endorsement on the documents infavour of BHEL. However BHEL will not be liable or responsible in any manner for the collection of Interest or renewal of the documents or in any other matter connected therewith.)

42. For extra items of work and deviated quantities, security deposit will be recovered at 10% of the value of deviated amount. The security deposit will be released as stipulated under clause 16 (IV) of GCC.

**43. Percentage rate contract:**

The tenderer shall quote a percentage above or below or at par, the rates shown in the Bill of Quantities based on CPWD DSR 2007. The percentage quoted shall be clearly written both in words and figures.

The quoted percentage will apply to the individual items uniformly and the item of work other than those mentioned in Bill of Quantities will have to be carried out at the rates to be fixed by the organization. The same offered percentage will be applicable with reference to CPWD DSR 2007.

44. **BHEL reserves the right of splitting the work as its discretion to TWO parties, at the rate of 60% of the order quantity on L1 and balance 40% on L2 at the ordering rate of L1.**
45. **Water will be issued on chargeable basis @ 1% of the contract value subject to availability at the nearest point and the contractor has to make their own arrangement for tapping the same. This will supersede Clause No. 24 of BHEL General Conditions of Contract.**



Bharat Heavy Electricals Limited  
Boiler Auxiliaries Plant,  
Ranipet –632 406

**ANNEXURE: B**

It is hereby agreed by me/us that the BHEL General Conditions of Contract including subsequent amendments/additions/deletions to clauses if any, and conditions pertaining to the settlement of disputes by Arbitration form an integral part of the tender documents and that the tender submitted by me/us is subject to the aforesaid BHEL General Conditions of Contract which has been read and accepted by me/us.

**CONTRACTOR**

**ISSUING OFFICER 9**



Bharat Heavy Electricals Limited  
Boiler Auxiliaries Plant,  
Ranipet –632 406

**ANNEXURE 'C'**

**CLAUSE 22 OF GENERAL CONDITIONS OF CONTRACT**

**LABOUR**

The contractor shall employ labour in sufficient numbers either directly or through sub-contractors to maintain the required date of progress and of quality to ensure workmanship to the degree specified in the contract and to the satisfaction of the Engineer – in – charge. The contractor shall not employ, in connection with the works, any person who has not completed eighteen years of age.

The Contractor shall pay to labour employed by him, either directly or through sub-contractors, wages not less than fair wages, as defined in the Contractor's Labour Regulations.

The Contractor shall in respect of labour employed by him, either directly or through sub-contractors, comply with or cause to be complied with contractor's labour Regulations in regard to all matters provided therein.

The Contractor shall comply with the provisions of the payment of Wages Act, 1936, Minimum Wages Act, 1948, Workmen's Compensation Act 1923, Industrial Disputes Act, 1947, Maternity Benefit Act 1961, or any modifications thereof or any other law relating there to and rules made there under from time to time.

The Contractor shall be liable to pay his contribution and the employee's contribution of the State Insurance Scheme in respect of all labour employed by him for the execution of the contract, in accordance with the provision of "The Employees' State Insurance Act, 1948" as amended from time to time. The Contractor shall apply to the ESI Authorities, get himself registered with them and obtain a code Number. He shall pay the remittances under his Code Number only.

The Contractor shall be liable to his contribution and the employees contribution towards PF as per Provident Fund Rules and Regulations, in respect of all labour employed by him for the execution of the contract. The Contractor shall apply to the PF Authorities, get himself registered and obtain a code number from them. He shall pay the remittances towards PF under his code number only.

The Engineer-in-charge shall, on a report having been made by an Inspecting Officer as defined in the Contractor's Labour Regulations, have the power to deduct from the moneys due to the contractor any sum required or estimated to be required, for making good the loss suffered by a worker or workers by reason of non fulfillment of the conditions of the contract for the benefit of workers, non-payment of wages or of deductions made a from his or their wages which are not justified by the terms of the Contract of non observance of the said Contractor's Labour Regulations.

The Contractor shall indemnify BHEL against any payment to be made under and for observance of the Regulations aforesaid without prejudice to his right to claim indemnity from his sub-contractors.

In the event of the Contractor committing a default or breach of any of the provisions of the aforesaid contractor's Labour Regulations, as amended from time to time or furnishing any information or submitting or filling any form/Register/Slip under the provisions of these Regulations which is materially incorrect, then, on the report of the Inspecting Officers as defined in the Contractors Labour Regulations, the Contractor shall without prejudice to any other liability

CONTRACTOR

ISSUING OFFICER 10



**Bharat Heavy Electricals Limited**  
**Boiler Auxiliaries Plant,**  
**Ranipet –632 406**

pay to BHEL a sum not exceeding Rs. 50/- as liquidated damages for every default, breach, or furnishing, making, submitting, filling materially incorrect statements as may be fixed by the Engineer-in-charge and in the event of the contractor's default continuing in this respect, the liquidated damages may be enhanced to Rs. 50/- per day for each day of default subject to a maximum percent of the estimated cost of works put to tender. The Contractor shall defend the case by himself any action brought in by such Government Agencies for non-compliance of any Labour Regulations and / or reimburse the expenses incurred by BHEL in this regard.

The Engineer-in-charge shall deduct such amount from bills or security deposit of the Contractor and credit the same to the welfare fund constituted under Regulations. The decisions of the Engineer-in-charge in this respect shall be final and binding.

**MODEL RULES FOR LABOUR WELFARE**

The Contractor shall, at his own expense, comply with or cause to be complied with Model Rules for Labour Welfare as appended to these conditions or rules framed by Government from time to time, for the protection of health and for making sanitary arrangements for workers employed directly or indirectly on the works. In case the Contractor fails to make arrangements as aforesaid, the Engineer-in-charge shall be entitled to do so and recover the cost there from the contractor.

**SAFETY CODE**

**RESPONSIBILITIES OF THE CONTRACTOR IN RESPECT OF SAFETY OF MEN,  
EQUIPMENT, MATERIAL AND ENVIRONMENT**

1. Before commencing the work, the contractor is required to submit a "SAFETY PLAN" to the authorized BHEL official. The 'safety plan' shall indicate, in detail, the measure that would be taken by the contractor to ensure safety of men, equipment, material and environment during execution of work. The plan shall take care to satisfy all requirements specified hereunder. The contractor shall submit safety plan along with his offer. During negotiations before placing of work order and during execution of the contract, BHEL shall have right to review and suggest modification in the safety plan. The contractor shall abide by BHEL's decision in this respect.
2. The contractor shall take all necessary safety precautions and arrange for appropriate appliances as per direction of BHEL, or its authorized officials, to prevent loss to human lives, injuries to personnel engaged, and damage to property and environment.
3. The contractor shall provide to its work force and ensure the use of the following personal protective equipment as found necessary and as directed by the authorized BHEL officials:-
  - (i) Safety helmets conforming to IS-2925: 1984.
  - (ii) Safety Belts conforming to IS-3521:1983
  - (iii) Safety Shoes conforming to IS-1989:1978.
  - (iv) Eye and Face protection devices conforming to IS-8520:1977. and IS-8940:1978.
  - (v) Hand and body protection devices conforming to
    - (1) IS-2573:1975 ( 2) IS-6994:1973 (3) IS-8807:1978 (4) IS-8519:1977.



**Bharat Heavy Electricals Limited**  
**Boiler Auxiliaries Plant,**  
**Ranipet –632 406**

All tools, tackles, lifting appliances, material handling equipment, scaffolds, cradles, safety nets, ladders, equipment etc. used by the contractor shall be of safe design and construction. These shall be tested and certificate of fitness obtained, before putting them to use and from time to time as instructed by authorized BHEL official who shall have the right to ban the use of any item.

All the electrical equipment, connections and wiring for constructions, power, its Distribution and use shall conform to the requirement of Indian Electricity Act and Rules. Only electricians licensed by the appropriate statutory authority shall be employed by the contractor to carry out the all types of electrical works. All electrical appliances including portable electric tools used by the contractor shall have safe plugging system to source of power and be appropriately earthed.

The contractor shall not use any hand – lamp energized by electric power with supply voltage of more than 24 Volts. For work in confined spaces, lighting shall be arranged with power source of not more than 24 Volts.

The contractor shall adopt all fire safety measures as laid down in the “Code for Fire Safety at Construction sites” issued by the safety department of BHEL and as per the directions of the authorized BHEL official. A copy of the above referred “Code for Fire Safety at Construction sites” shall be made available by BHEL to the contractor for reference, on demand by the contractor, during tendering stage itself.

Where it becomes necessary to provide and/or store Petroleum Products, explosives, chemicals and liquid or gaseous fuel or any other substance that may cause fire or explosion, the contractor shall be responsible for carrying out such provisions and / or storage in accordance with the rules and regulations laid down in the relevant government acts, such as Petroleum Act, Petroleum and Carbides of Calcium Manual of the Chief Controller of Explosives, Govt. of India etc., Prior approval of the authorized BHEL official at the site shall also be taken by the contractor in all such matters.

The contractor shall arrange at his cost (wherever not specified), appropriate illumination at all work spots for safe working when natural daylight may not be adequate for clear visibility.

The contractor shall be held responsible for any violation of statutory regulations local, state or central and BHEL instructions, that may endanger safety of men, equipment, material and environment in his scope of work or another contractor's or agency's. cost of damages if any, to life and property arising out of such violation of statutory regulations and BHEL instructions, shall be borne by the contractor.

In case of fatal or disabling injury/accident to any person at construction sites due to lapses by the contractor, the victim and/or his/her dependents shall be compensated by the contractor as per statutory requirements. However, if considered necessary, BHEL have the right to impose appropriate financial penalty on the contractor and recover the same from payments due to the contractor for suitably compensating the victim and/or his/her dependents. Before imposing any such penalty, appropriate enquiry shall be held by BHEL giving opportunity to the contractor to present his case.

In case of any damage to property due to lapses by the contractor, BHEL shall have the right to recover cost of such damages from payments due to the contractor after holding an appropriate enquiry.

In case of any delay in the completion of a job due to mishaps attributable to lapses by the contractor, BHEL shall have the right to recover cost of such delay from payments due to the contractor, after notifying the contractor suitably and giving him opportunity to present his case.

CONTRACTOR

ISSUING OFFICER 12



Bharat Heavy Electricals Limited  
Boiler Auxiliaries Plant,  
Ranipet –632 406

If the contractor fails to improve the standards of safety in its operation, to the satisfaction of BHEL, after being given a reasonable opportunity to do so and / or / if the contractor fails to take appropriate safety precautions or to provide necessary safety devices and equipment or to carry out instructions regarding safety issued by the authorized BHEL official, BHEL shall have the right to take corrective steps at the risk and cost of the contractor, after giving a notice of not less than seven days, indicating the steps that would be taken by BHEL.

The contractor shall submit report of all accidents, fires and property damage, dangerous occurrence to the authorized BHEL official immediately after such occurrence, but in any case not later than twelve hours of the occurrence. Such reports shall be furnished in the manner prescribed by the contractor to the authorized BHEL official from time to time as prescribed.

Before commencing the work, the contractor shall appoint/nominate a responsible office to supervise implementation of all safety measures and liaison with his counterpart of BHEL.

If the Safety record of the contractor is to the satisfaction of Safety Department of BHEL, issue of an appropriate certificate to recognize the safety performance of the contractor may be considered by BHEL after completion of the job.



Bharat Heavy Electricals Limited  
Boiler Auxiliaries Plant,  
Ranipet –632 406

**ANNEXURE: 'D'**

**Terms & Conditions**

01. The contract is for a period of 6 months.

02. The offer shall be submitted in two parts

- a) Technical and Commercial Bid
- b) Price Bid

The technical bid shall cover all the technical details like

- (i) The Experience of the contractor i.e., the eligibility criteria of the tenderer shall be as specified in the tender notice.
- (ii) The list of technical personnel in their organization with their qualification & experience in the field.
- (iii) The infrastructure available with them
- (iv) The certificates received from the Government/reputed organizations for having taken up similar work of equivalent value.
- (v) The list of clients with their addresses, contact persons.
- (vi) The list of works being done at present with the details of Contact persons and addresses.
- (vii) The EMD in the form of DD shall be drawn in favour of "Bharat Heavy Electricals Limited, Ranipet 632 406 payable at Ranipet, Vellore Dist. T.N.
- (viii) EMD shall be enclosed along with Technical Bid only.
- (ix) The details of the tenderer's office with full address, Phone No. FAX No., Mobile No. shall be specified on the Tender document cover. If the tenderer gives wrong information, then the EMD submitted by the tenderer will be forfeited.

Prices shall be quoted in the price schedule as per the **Bill Of Quantities**.

03. The contractor shall comply with all statutory regulations like ESI, PF Contract Labour License (if applicable), Minimum Wages Act etc.,

04. The rate quoted shall include the wages payable to the employees, Statutory charges like ESI, PF, Bonus, Holiday & EL wages, safety appliances etc., While quoting the rate, the contractor shall take into account, the implication of probable revision in the minimum wages also.

05. The contractor shall issue necessary safety appliances like Safety Shoes, Gum Boots, Acid & Alkali Proof Hand Gloves, Masks etc., to their workers for safe operation.

CONTRACTOR

ISSUING OFFICER 14



Bharat Heavy Electricals Limited  
Boiler Auxiliaries Plant,  
Ranipet –632 406

06. The contractor shall maintain all the records w.r.t. ESI, PF, Wages & Attendance.
07. The tenderer shall fill up the questionnaire as per **Annexure – 1** and enclose along with Technical bid.
08. The minimum wages from **01.04.2009** will be as follows:

**USW -149.00**

**SSW -156.00**

**HSW -162.00**

Please note that the minimum wages are normally revised by the authorities from every year April month.

**If any employee / labourer working in the contract is found involved in corruption activities, the contract will be terminated and the contractor will be banned for applying for any future contract for 3 years.**

09. Normally, no advance payment shall be paid to the contractor.
10. However, advance payment in exceptional circumstances, if specifically provided shall be interest bearing and secured through an equivalent bank guarantee and shall be limited to a maximum of 5% of the contract value.  
  
Recovery of advances will be made from the running bills progressively such that the amount paid along with the interest is fully recovered by the time the contractor reaches 90% billing of total value of works to be executed. (Interest rate shall be the prime lending rate of SBI plus 2%).
11. During the progress of the work progressive payment will be made to the contractor on production of invoice with necessary statutory clearance and the bill will be processed within 15 days from the date of submission all the relevant documents.
12. All Payments will be made only through e-Mode, necessary authorization as to be submitted along with the tender as per the format enclosed.



Bharat Heavy Electricals Limited  
Boiler Auxiliaries Plant,  
Ranipet –632 406

**SCHEDULE – A**  
**LIST OF WORKS AND PRICES**

Details and quantities of each item shown in the bill of quantities here to are only approximate. They are given as a guide for the purpose of tendering only and are liable to variation and alteration at the discretion of the competent authority. The work under each item as executed shall be measured and priced at the corresponding rate quoted by the contractor in the bill of quantities attached hereto.

SI.No.	Description of work/supply	Total amount of work/supply (in figures and words)	Period of Completion
1	<b>Part 1 Civil works for extension of New Fabrication bay and Existing MP shop in Factory &amp; Part 2 Construction of New Fastener stores inside Factory.</b>	<b>As per BOQ</b>	6 months.

CONTRACTOR

ISSUING OFFICER 16



Bharat Heavy Electricals Limited  
Boiler Auxilaries Plant,  
Ranipet –632 406

**BILL OF QUANTITIES  
ANNEXURE TO SCHEDULE – A**

**NAME OF WORK: Part 1 Civil works for extension of New Fabrication bay and Existing MP shop in Factory & Part 2 Construction of New Fastener stores inside Factory.**

SL.NO.	APPROXIMATE QUANTITY	DESCRIPTION OF WORK/SUPPLY	SPECIFICATION	RATE (both in figures and words)	UNIT	AMOUNT
--------	-------------------------	-------------------------------	---------------	-------------------------------------	------	--------

As per separate sheets attached

CONTRACTOR

ISSUING OFFICER 17



Bharat Heavy Electricals Limited  
Boiler Auxiliaries Plant,  
Ranipet –632 406

SCHEDULE – B

ISSUE OF STORES TO THE CONTRACTOR

1. The following materials will be issued to the contractor at BHEL stores/stock yard.

SL.NO.	DESCRIPTION	PLACE OF	ISSUE RATE
1	Cement	BHEL Stores or Stock Yard	Free issue
2	MS Reinforcement rods cold twisted deformed rods	BHEL Stores or Stock Yard	Free issue
3	Structural Steel	BHEL stores or stock yard	Free issue

2. It will be the responsibility of the contractor to submit his indents for the above stores in writing at least SEVEN days in advance of the actual requirements

3. Issue of stores is subject to their availability at the place of issue noted above. Items of stores to be issued by BHEL, which are not available at the time of indenting by the contractor, may be supplied by BHEL after necessary procurement. The contractor shall not be entitled to any claim or compensation for delay in the supply of stores by BHEL under any circumstances.

4. The material will be issued only during the working hours of the BHEL stores department.

5. The contractor shall from time to time, render proper account of all materials issued to him by BHEL. If he fails to do, no further issue of materials will be made to him and he will be responsible for any delay in the execution of the work, which may occur on this account.

6. All surplus materials in good condition, which are not returned to the BHEL Stores and quantities of materials consumed in excess of max. Permissible limit as fixed by BHEL shall be charged for at punitive rates, which will be 100% higher than the recovery rates.

7. The steel materials if issued will be in random lengths and sizes as stocked by the BHEL and the cost of all cutting, conversion, substitution and fabrication as well as wastage shall have to be borne by the contractor.

8. The Structural and reinforcement steel will be issued at free of cost at BHEL stores, Recovery for the excess consumption up to 5% over and above theoretical consumption will be recovered as stated in the special condition. Beyond 5% punitive rate shall be charged, which will be 100% higher than the recovery rate specified above.

9. The decision of the accepting officer/Engineer-in-charge as the case may be as to the extent to which materials have been rendered surplus or consumed in excess of the actual requirements shall be final, conclusive and binding on the contractor.

10. The present recovery rate for the excess consumption of free issue materials up to 5% will be as follows:

- Cement = Rs. 6325.00 / M.T.
- Reinforcement Steel = Rs. 41,975.00 / M.T.
- Structural Steel = Rs. 46500.00 / M.T.

And will vary depending on the issue during the construction.

CONTRACTOR

ISSUING OFFICER 18



Bharat Heavy Electricals Limited  
Boiler Auxiliaries Plant,  
Ranipet -632 406

**SCHEDULE – C**  
**LIST OF TOOLS AND PLANTS TO BE ISSUED ON HIRE TO CONTRACTOR**

SL.NO.	QUANTITY	PARTICULARS	HIRE CHARGES PER UNIT PER DAY OF 8 HOURS	PLACE OF ISSUE	REMARKS
--------	----------	-------------	------------------------------------------------	----------------	---------

-NIL -

- Machinery shall not be worked overtime without the written permission of the Engineer-in-charge and cost of liability of the same will be contractor's.
- All coolies, waterman, etc., required in addition to BHEL crew mentioned in Column 4 above shall be arranged for by the contractor at his own expense.

CONTRACTOR

ISSUING OFFICER 19



Bharat Heavy Electricals Limited  
Boiler Auxilaries Plant,  
Ranipet –632 406

## SCHEDULE – D

NOTE: All drawings are to be signed by the contractor as well as the officer entering in to contract.

NAME OF WORK: **Part 1** Civil works for Extension of New Fabrication Bay and MP shop in Factory & **Part 2** Construction of New Fastener Stores inside Factory.

SL.NO.	DRAWING NUMBER	DESCRIPTION
01	BHE-BAP-C-10-1706	GA for Welding Technology Centre.
02	BHE-BAP-C-10-1707	GA for Fabrication Bay Extension.
03	BHE-BAP-C-10-1711	Layout of Building.

CONTRACTOR

ISSUING OFFICER 20



Bharat Heavy Electricals Limited  
Boiler Auxiliaries Plant,  
Ranipet –632 406

**ANNEXURE - 1**

**Questionnaire should be answered by the tenderer by ticking the suitable boxes. Non filling up and signing liable for rejection at the discretion of the BHEL**

Sl.No.	Description	Reference	Yes	No
01	Whether the tenderer <b>has understood</b> the scope of work and agrees to deploy manpower as indicated in the tender. (If there is any clarification required, the same may be got cleared from the Executive-in-charge, before submitting the offer.)	12 of Instructions to tenderers & Annexure-C		
02	Whether the tenderer <b>has agreed to all Terms &amp; Conditions given in the tender.</b> (If there is any deviation, the same may be mentioned in separate sheet.)	(Annexure D)		
03	Whether the tenderer has their <b>own code for ESI &amp; PF.</b> A copy of the certificate enclosed	36 of Instructions to tenderers		
04	Whether the tenderer has enclosed <b>copy of the present Service/Sales/Works contract sales Tax registration certificates.</b> If a vendor is exempted from the registration under Service/Sales Tax, the reason there of be stated.	21(i) of Instructions to tenderers		
05	Whether the <b>vendor/Contractor is availing service Tax credit/VAT Credit for their inputs.</b>			
06	Whether the vendor will submit <b>VAT/Service Tax invoice</b> as per the existing ACT and the rules their under.			
07	Whether the tenderer <b>agrees to Pay Wages as per Minimum wages Act, EL Wages, Holiday Wages</b> as per Tamilnadu Factory rules. (Necessary proof should be submitted while claiming running bill and final bill.)	(Annexure D)		
08	Whether the <b>PAN Number of the vendor</b> is furnished. If exempted from IT, the exemption certificate shall be enclosed.	21(iv) of Instructions to tenderers		
09	Whether the tenderer agrees to keep the validity of their offer for <b>three months</b> from the date of opening of bid.	10 (a) of Instructions to tenderers		
10	Whether the tenderer <b>agrees for the payment terms BHEL..</b>	Clause 56 of GCC		
11	Whether the tenderer has agreed to submit <b>EMD of Rs.2,00,000/-</b> and has submitted the same <b>along with technical bid.</b> (If not enclosed the tender will not be considered.)	Page 1 of Instructions to tenderers		
12	Whether the tenderer has agreed to <b>submit Security Deposit before start of the work</b>	40 of Instructions to tenderers		
13	Whether the tenderer has <b>enclosed the list of their clients with addresses &amp; contact persons.</b>	21(i) of Instructions to tender		
14	Whether the tenderer has enclosed <b>the certificates/evidence of Government/Reputed organization</b> for the similar work done			

CONTRACTOR

ISSUING OFFICER 21



Bharat Heavy Electricals Limited  
Boiler Auxiliaries Plant,  
Ranipet –632 406

15	Whether the tenderer has enclosed the <b>list of similar works Carried out</b> with supporting documents	21(i) of Instructions to tenderers		
16	Whether the <b>includibility/excludability of the taxes and duties</b> in the rates offered has been clearly indicated. If the same is not done, BHEL WILL CHOOSE TO ASSUME THE RATES ARE INCLUSIVE ONLY.			
17	All payments will be made through <b>e-payment</b> only for which required certificate to be submitted along with tender as per the enclosed format.	<b>(Annexure D)</b>		
18	Whether the tenderer has enclosed the <b>list of technical personnel</b> , their qualification & experience who will be deployed for this work.			
19	Whether the tenderer has indicated the address of their local office in Ranipet along with phone no. & fax no.			
20	Whether the tenderer has enclosed <b>the solvency certificate</b> obtained from a bank for a value of <b>Rs.-----</b> <b>----- minimum.</b>			
21	Whether the tenderer has enclosed the certificate to establish that the tenderer is an <b>independent contractor</b> working on his own.			
22	Whether the tenderer agreed for the period of completion mentioned in schedule A			
23	Whether the tenderer agreed for the advance as specified in the terms & conditions given in Annexure D			
24	Whether the tenderer agreed for the compensation for delay as specified in clause 43 of General Conditions of Contract.	Clause 43 of GCC		

Note: If any of the question is not applicable, please mention as "N. A."



Bharat Heavy Electricals Limited  
Boiler Auxiliaries Plant,  
Ranipet –632 406

**AUTHORITY TO TENDER**

Tender Notice No. : BAP:CF:17/2009-10dt 12.09.09 Office of the Sr. Deputy General  
Manager, Bharat Heavy Electricals  
Limited, Ranipet

Tender Schedule No. :

Percentage rate tender for works required in BHEL – Ranipet. Messers / Mr.

.....of.....

are / is hereby authorized to tender for the above work. The tender is to be delivered at the Office of the Sr.Dy.General Manager / Civil Projects & Services by 14.30 hours on 10.10.2009 addressed to the Office of the Sr.Dy.General Manager (Civil Projects & Services) Bharat Heavy Electricals Limited, Ranipet – 632 406 subscribed “tender” for the work of **Part 1 Civil works for Extension of New Fabrication Bay and MP shop in Factory & Part 2 Construction of New Fastener Stores inside Factory.**

Any correspondence concerning this Tender should be addressed as indicated above quoting the Tender Notice and Schedule Nos. and other relevant particulars.

Bharat Heavy Electricals Limited do not Bind Themselves to Accept the Lowest or any tender. Further Bharat Heavy Electricals Limited reserve the right to reject any or all the Tender Received or Accept any Tender or Part Thereof without Assigning any Reason therefor.

Signature of the Officer,

Issuing the documents

CONTRACTOR

ISSUING OFFICER 23



Bharat Heavy Electricals Limited  
Boiler Auxiliaries Plant,  
Ranipet –632 406

## TENDER

To.

The Bharat Heavy Electricals Limited,

Boiler Auxiliaries Plant,

Ranipet 632 406.

I/We hereby offer to carry out the work of **Part 1 Civil works for extension of New Fabrication bay and Existing MP shop in Factory & Part 2 Construction of New Fastener stores inside Factory.**

I/We have carefully perused the following documents connected with the above noted work and agree to abide by the same.

1. Specifications (General & particular)
2. Drawings.
3. Schedule 'A','B','C','D','E' and Bill of Quantities attached hereto.
4. BHEL General & Special conditions of contract. Tender Notice, **Annexures** and Instruction to Tenderers attached hereto,.

I/We forward herewith the sum of Rs. 2,00,000/- as Earnest Money which shall be refunded **if this tender is unsuccessful.** I/We further agree to deposit such sum which along with the sum of Rs. 2,00,000/- mentioned above shall make up the full Security Deposit for this work as provided for under condition 18 of the Bharat Heavy Electricals Limited, General Conditions of Contract.

I/We further agree to execute all the work referred to in the said documents upon the terms and conditions contained or referred to therein and as detailed in schedule 'A' and Bill of Quantities annexed thereto and to carry out such deviations as may be ordered vide condition 6 of the BHEL General Conditions of Contract up to a **maximum of 20%** of tendered amount.

I/We further agree to refer all disputes, as required by condition 60 of the said General Conditions of Contract, to the Sole Arbitration of an Officer, to be appointed by the General Manager, BHEL, in his sole discretion, whose decision shall be final and binding on both the parties.

Witness:

1.

2.

Signature of the Tenderer,

Date:

Accepting officer

CONTRACTOR

ISSUING OFFICER 24



Bharat Heavy Electricals Limited  
Boiler Auxiliaries Plant,  
Ranipet –632 406

S.No.	PARTICULARS	YES	NO
<b>01</b>	<b>SERVICE TAX</b>		
<b>a.</b>	Service Tax Registration No. of Tenderer (copy to be enclosed)		
<b>b.</b>	Issue of Service Tax Invoice as per Rule 9 of Cenvat Credit rules 2004		
<b>c.</b>	Whether Tenderer is taking Service Tax Credit for their Inputs		
<b>d.</b>	Under which Service Head is Service provided		
<b>e.</b>	If Service Tax is Exempted , furnish reasons		
<b>f.</b>	BHEL Service Tax Registration No. ( To indicate in your Invoice) : <b>AAACB/4146/PST/008</b>		
<b>02</b>	<b>INCOME TAX</b>		
<b>a.</b>	PAN No. of Tenderer		
<b>b.</b>	If Exempted , furnish exemption Certificate		
<b>c.</b>	PAN No. of BHEL : <b>AAACB/4146/P</b>		
<b>03</b>	<b>WC ST</b>		
<b>a.</b>	CST Registration No.		
<b>b.</b>	VAT Registration No.		
<b>c.</b>	Whether Tenderer is availing VAT Credit		
<b>d.</b>	If Exempted , furnish Reasons		
	<b>NOTE :</b>		
	1. Rates Quoted shall be clearly indicated whether they are <b>INCLUSIVE</b> or <b>EXCLUSIVE</b> of specific Taxes & Duties. Otherwise generally it is presumed that the rate are inclusive and the Contractor has to issue invoice accordingly.		
	2. Payment will be made only through e-payment to your account. No Cheque payment is entertained.		
<b>04.</b>		<b>Tenderer</b>	<b>BHEL</b>
<b>a.</b>	Name & Address		BHEL, BAP, Ranipet-406
<b>05.</b>	<b>Details of Bank Account :</b>		
<b>a.</b>	Centre		RANIPET
<b>b.</b>	Name of the Bank		S.B.I
<b>c.</b>	Branch Code & Name		7013, Mukundarayapuram
<b>d.</b>	Account Number		10664849171
<b>e.</b>	Type of Account		Cashcredit
<b>f.</b>	Beneficiary's Name		BHEL , Ranipet
<b>g.</b>	IFSC Code of the Branch		SBIN0007013
<b>Tenderer has to submit Banker's Certificate as per the following format specified by BHEL along with the tender.</b>			
<b>Agreed to the Above Conditions</b>			
<b>Signature of the Tenderer :</b>			

CONTRACTOR

ISSUING OFFICER 25



Bharat Heavy Electricals Limited  
Boiler Auxiliaries Plant,  
Ranipet –632 406

**ACCEPTANCE FOR ELECTRONIC FUND TRANSFER / RTGS TRANSFER**

01	NAME & ADDRESS OF THE SUPPLIER / VENDOR	
02	VENDOR CODE (as in Purchase Order)	
03	<b>Details of Bank Account:</b>	
A)	NAME & ADDRESS OF THE BANK (WITH PIN CODE)	
B)	BANK TELEPHONE NUMBER (WITH STD CODE)	
C)	BANK BRANCH CODE	
D)	MICR CODE	<input type="text"/>
E)		<input type="text"/>
F)	TYPE OF ACCOUNT	CURRENT A/C / OD / CASH CREDIT
G)	VENDOR NAME AS PER BANK RECORDS	
H)	BANK BRANCH RTGS IFSC CODE	<input type="text"/>
I)	BANK BRANCH NEFT IFSC CODE	<input type="text"/>
J)	YOUR EMAIL ID (give two ids)	
K)	NAME OF AUTHORISED SIGNATORY	

**CERTIFICATE**

I / We hereby agree to receive the payments due from BHARAT HEAVY ELECTRICALS LIMITED, RANIPET by the National Electronic Funds Transfer and/or RTGS Transfer mode by credit to my / our above mentioned Bank Account. I / We also agree that payments made to the above mentioned Account is a valid discharge of the liability of Bharat Heavy Electricals Limited, Ranipet. I / We also agree to bear the applicable Bank Charges for the above mode of transfer.

AUTHORISED SIGNATORY OF VENDOR WITH SEAL

**Banker's Certification**

We confirm that we are enabled for receiving RTGS and NEFT credits and we further confirm that the \_\_\_\_\_ account \_\_\_\_\_ number of \_\_\_\_\_ (name of account holder), the signature of the authorized signatory and the MICR and IFSC codes of our Branch mentioned above are correct.

PLACE:

\_\_\_\_\_

DATE:

(Manager / Officer's  
signature Under Bank stamp)

CONTRACTOR

ISSUING OFFICER 26

GENERAL CONDITIONS OF CONTRACT  
FOR  
LUMP SUM, ITEM RATE AND  
PERCENTAGE CONTRACT

SPECIMEN

civ 02

GCC



**Bharat Heavy Electricals Limited**  
BOILER AUXILIARIES PLANT  
RANIPET - 632406

**GENERAL CONDITIONS OF CONTRACT  
FOR  
LUMP SUM, ITEM RATE AND  
PERCENTAGE CONTRACT**



**Bharat Heavy Electricals Limited**

**BOILER AUXILIARIES PLANT  
RANIPET - 632 406.**

# CONTENTS

Condition No.	Description	Page No.
<b>CHAPTER - I</b>		
1.	DEFINITIONS	1
<b>CHAPTER - II</b>		
<b>SCOPE OF CONTRACT</b>		
2.	HEADING TO THE CONTRACT .....	4
3.	CONTRACT DOCUMENTS .....	4
3A.	SECRECY .....	4
4.	WORKS TO BE CARRIED OUT .....	4
5.	PROVISIONAL ITEMS .....	5
6.	DEVIATIONS .....	5
7.	TIME .....	6
8.	STORES & MATERIALS .....	7
9.	DELAY & EXTENSION OF TIME .....	9
10.	PATENT RIGHTS .....	10
11.	OCTROI & OTHER DUTIES .....	10
12.	ROYALTIES .....	10
13.	PLANT & EQUIPMENT .....	10
14.	ASSIGNMENT OR TRANSFER OF CONTRACT .....	11
	a) SUB - CONTRACT .....	11
15.	COMPLIANCE TO REGULATIONS AND BYE-LAWS .....	11
16.	DELETED .....	11
17.	DELETED .....	11

## CHAPTER - III

### SCOPE OF CONTRACT

18.	SECURITY DEPOSIT .....	12
19.	ORDERS UNDER THE CONTRACT .....	13
20.	ADMISSION TO SITE .....	13
21.	CONTRACTOR'S SUPERVISION .....	14
22.	LABOUR LAWS .....	15
23.	SAFETY RULES .....	15
24.	WATER .....	15
25.	TEMPORARY WORKSHOPS, STORES ETC. ....	15
26.	TOOLS & PLANT ON SITE .....	16
27.	STATEMENT OF HIRE CHARGES .....	16
28.	PRECAUTIONS AGAINST RISKS .....	16
29.	NOTICE & FEES .....	16
30.	SETTING OUT OF THE WORKS & PROTECTING & MAINTAINING SIGNALS AND WORKS .....	16
31.	SITE DRAINAGE .....	17
32.	EXCAVATIONS, RELICS ETC., .....	17
33.	FOUNDATIONS .....	17
34.	COVERING IN WORK .....	17
35.	APPROVAL OF WORKS BY STAGES .....	18
36.	EXECUTION OF WORKS .....	18
37.	DAY WORK .....	18
38.	INSPECTION OF THE WORK .....	18
39.	RESPONSIBILITY FOR BUILDING .....	19
40.	INSURANCE OF WORKS .....	19

41.	DAMAGE AND LOSS TO PRIVATE PROPERTY & INJURY TO WORKMEN .....	20
42.	COMPLETION .....	20
43.	COMPENSATION FOR DELAY .....	21
44.	LAWS GOVERNING THE CONTRACT .....	21
45.	CANCELLATION OF CONTRACT FOR CORRUPT ACT .....	22
46.	CANCELLATION OF CONTRACT FOR INSOLVENCY .....	22
	ASSIGNMENT OF SUB-LETTING OF CONTRACT	
47.	CANCELLATION OF CONTRACT FOR DEFAULT .....	23
48.	TERMINATION OF CONTRACT FOR DEATH .....	24
49.	SPECIAL POWERS OF DETERMINATION .....	24
50.	DELETED .....	24

## CHAPTER - IV

### VALUATION AND PAYMENT

51.	RECORDS & MEASUREMENTS .....	25
52.	VALUATION OF DEVIATIONS .....	26
53.	REIMBURSEMENT / REFUND ON VARIATION IN PRICE .....	27
54.	ADVANCES ON ACCOUNT .....	28
55.	FINAL BILL .....	29
56.	PAYMENT OF BILLS .....	29
57.	RECOVERY FROM CONTRACTORS .....	30
58.	POST-TECHNICAL AUDIT OF WORK AND BILLS .....	30
59.	REFUND OF SECURITY DEPOSIT .....	30
60.	ARBITRATION .....	30
61.	JURISDICTION OF COURT .....	31
62.	PAYMENT OF TAXES, DUTIES & LEVIES .....	31

## ANNEXURE

LABOUR LAWS	ANNEXURE - I .....	32
SAFETY RULES	ANNEXURE - II .....	50

## CHAPTER - I

### DEFINITIONS IN THE CONTRACT AS HEREINAFTER DEFINED

The following terms shall have the meanings hereby assigned to them, except here the context otherwise requires :-

- a. **'CONTRACT'** means and includes the conditions of contract, the documents forming the tender and acceptance, thereof, specifications, drawings, bill of quantities, schedule of rates and prices if any, general and special conditions of contract, schedules A,B,C,D and or general summary attached to the form of tender and contract agreements. All these terms and conditions and documents as applicable taken together shall be deemed to form one contract and thereby complementary to one another.
- b. **'TENDER DOCUMENTS'** means and includes the form of tender, the applicable schedules A, B, C, D and / or general summary, general and special conditions of contract and specifications and drawings as given to the contractors on payment.
- c. **'THE CONTRACTOR'** means the person or persons, firm or company whether incorporated or not, whose tender is being accepted and includes the contractor's legal / personal representatives, successors and permitted assignees.
- d. **'THE WORK'** means the work described in the tender documents and / or individual work orders, drawings and specifications as may be issued from time to time to the contractor by the Engineer - In - Charge within the powers conferred upon them including modified or additional works and obligations to be carried out either at the site or at any factory, workshop or any other place as required for the performance of the contract.
- e. **'THE SITE'** means the lands and other places on, under, in or through which the work has to be executed under the contract and any other lands and places provided by the company for the purpose of carrying out the contract.
- f. **'THE COMPANY'** referred to as BHEL in this contract shall mean M/s. Bharat Heavy Electricals Limited including its Board of Directors, Director, Executive Director, Group General Manager, General manager, Dy. General Manager and / or the Officers of the company including Sr. Manager, Manager, Dy. Manager, Sr. Engineer and Engineer authorised on behalf of Bharat Heavy Electricals Limited, Boiler Auxiliaries Plant, Ranipet.
- g. **'THE ACCEPTING OFFICER'** means the official who signs the contract agreement on behalf of Bharat Heavy Electricals Limited and includes his successors.
- h. **'ENGINEER-IN-CHARGE'** means the Officer / Engineer of BHEL who is in charge of works under the contract and includes such other Officer / Engineer as may be notified by BHEL from time to time.
- i. **'APPROVED AND DIRECTED'** means approval and / or directions of the Officers / Engineers of BHEL issued from time to time with regard to the contract.

- j. In the case of Lump-sum Contracts '**CONTRACTOR'S PERCENTAGE**' means the percentage offered by the Contractor as addition to our deduction from the cost of building, or other works listed in Schedule "A" to provide a Lump-sum quotation for performance of the contract inclusive of all extra costs, profit, establishment charges, carriage, insurance etc., complete.
- In the case of percentage Rate "Contracts Contractor's Percentage" shall, if the context so permits mean the uniform percentage tendered by the Contractor and accepted by the Accepting Officer; and the expression '**CONTRACT RATE**' shall likewise mean the rates in the BHEL Schedule of Rate applicable as on date as adjusted by the said Contractor's percentage, if any.
- k. '**THE CONTRACT SUM**' means the sum accepted or the sum calculated in accordance with the prices accepted in the tender and / or the contract rates as payable to the contractor for the execution and full completion of the work.
- l. The '**FINAL SUM**' means the actual amount payable under the Contract by BHEL, to the Contractor for the entire Execution and full completion of the work.
- m. The '**DATE OF COMPLETION**' is the date or dates for completion of the whole or any part of the work as the case may be set out in or ascertained in accordance with the individual work orders of the tender documents, or any subsequent agreed amendments thereto.
- n. A '**WEEK**' means seven days without regard to the number of hours worked or not in any day in that week.
- o. A '**DAY**' means a day of 24 (Twenty Four) hours irrespective of the number of hours worked or not in that day.
- p. A '**WORKING DAY**' means any day other than the holidays declared by BHEL, Ranipet.
- q. '**DEVIATION ORDER**' means an order given by the Engineer-in-Charge to effect an alternation addition or deduction which does not radically affect the scope or nature of the contract.
- r. '**EMERGENCY WORKS**' means any urgent measures which in the opinion of the Engineer-In-Charge, become necessary during the progress of the work to obviate any risk of accident or failure which become necessary for security.
- s. '**PROVISIONAL SUM**' or "Provisional Lump-sum" means a Lump-sum included by the BHEL in the tender documents and represents the estimated value of work for which details are not available at the time of inviting the tender.
- t. '**PROVISIONAL ITEMS**' means items for which approximate quantities have been included in the tender documents.
- u. '**DAY WORK**' means an item of work requiring the employment of labour with or without materials as the case may be which in the opinion of the Engineer-in-charge, is not capable of being evaluated by the accepted methods of measurement or assessment and is paid for on the basis of the actual labour and materials utilised on the particular item of work referred to.

- v. Heading of these terms and conditions shall not affect the interpretation or construction thereof.
- w. The '**DATE OF CONTRACT**' shall mean the date / dates on which the parties to the contract have signed the contract agreement.
- x. **MAINTENANCE PERIOD / GUARANTEE PERIOD** shall mean the period during which the contractor shall remain liable for satisfactory performance of the work under the contract, repair or replacement of any part of the work performed under the contract.
- y. '**COST**' shall mean and include any liability, expenditure, overhead costs whether on the site or off the site incurred by BHEL.

The contractor shall be deemed to have carefully examined all the documents to his satisfaction. If he shall have no doubt as to the manner of the contract document, he shall obtain the details/clarification from BHEL before signing the contract.

#### **MANNER OF EXECUTION OF CONTRACT**

The contract shall be deemed to have come into force from the date of Letter of Intent unless otherwise provide in the Letter of Intent. Unless and until the contract agreement is executed, the Letter of Intent read in conjunction with the tender documents will constitute a binding contract.

**CONTRACTOR / TENDER**

**ACCEPTING OFFICER**

## CHAPTER - II

### SCOPE OF CONTRACT

#### 2. Heading to the Contract

The heading to these conditions shall not affect the interpretation thereof.

#### 3. Contract Documents

The Accepting Officer shall furnish to the Contractor on demand "FREE OF COST" three copies of signed Drawings and one copy of the signed agreement comprising of preamble to agreement, General and Special Specification, Schedule A,B,C & D etc., (but excluding General Conditions of Contract and Drawings) and three copies of all further drawing issued the progress of work.

However, for any additional copies of the agreement of drawings required by the Contractor, the same will be supplied on payment of the Specified cost.

The Contractor shall keep one copy of all the Drawings and of the Specifications on the site and the Engineer-in-Charge or his representative shall be at all reasonable times have access to them.

None of these documents shall be used by the contractor for any purpose other than that of this contract.

#### 3a. Secrecy

The Contractor shall take necessary steps to ensure that all persons employed on any work in connection with this contract have noted that the Indian Officials Secrets Act 1923 (XIX of 1923) applies to them and shall continue so to apply even after the execution of such work under the contract.

All classified documents furnished to the contractor shall be returned to the Engineer-in-charge on the completion of works or the earlier determination of the Contract.

#### 4. Works to be Carried Out

The Contract shall, except as provided under Schedules "B" and "C" included all labour materials, tools, plant, equipment, and transport which may be required in preparation for and in the entire execution and full completion of the work. Schedule "A" shall be deemed to have been prepared in accordance with good practice and recognised principles and unless otherwise stated, the descriptions given therein shall be held to include waste on materials carriage and cartage, lead, hoisting, setting, fitting in position and all other labour necessary in and for the entire execution and full completion aforesaid. Any error in description or quantity in Schedule "A" or any omission therefrom shall not vitiate the Contract or release the Contractor from the execution of the whole or any part of the work comprised therein according to the Drawings and Specifications, or from any of his obligations under the Contract.

The insertion of the name of any firm of suppliers in the Tender Documents is for the purpose of obtaining a particular class or quality of materials or workmanship but the articles or materials specified may be obtained from any other firm subject to prior written approval of the Engineer-in-Charge.

In the case of a discrepancy between Schedule "A" the specification and / or the Drawings, the Accepting Officer shall be the sole deciding authority as to which shall prevail and his decision shall be final and conclusive. If neither Drawings nor specifications contain any mention of minor details of construction, which is in the opinion of the Accepting Officer, whose decision shall be final and conclusive, are reasonable and obviously and fairly intended for the satisfactory completion of the work, such details shall be provided by the Contractor without any extra cost as if they were specially mentioned and shall be deemed to be included in the contract.

The Contractor will be deemed to have satisfied himself as to the nature of the site, local facilities of access and all matters affecting the execution and completion of the work. No extra charges consequent on any mis-understanding in these respects or otherwise will be allowed.

#### **5. Provisional Items**

The full amount of provisional Lump-sums and the value annexed to each provisional item inserted in the Tender Documents shall be deducted from the contract sum and the value of work ordered and executed there under shall be ascertained by measurement or valuation as for deviations.

No work under these items is to be begun without instructions in writing from the Engineer-in-charge.

The extent of quantities or items described as "Provisional" shall not be held to guarantee or limit the amount and description of the work to be executed by the Contractor either in respect of the items concerned or the work as a whole.

No addition or deduction shall be made by the Contractor to the amount of the provisional Lump-sum as included in the tender documents.

#### **6. Deviations**

The contractor shall not make any alteration in addition to or omission from the work as described in the tender documents except in pursuance of the written instructions of the Engineer-in-charge. No such deviation from the work described in the tender documents shall be valid unless the same has been specifically confirmed and accepted by the Accepting Officer in writing and incorporated in the contract.

The Accepting Officer may deviate either by way of addition or deduction, from the work so described, provided that the contract sum be not thereby varied on the whole by more than percentage set out in the tender documents. The value of all additions and deductions will be added to or, deducted from the contract sum, when ever the Accepting Officer intends to exercise such a right, his intentions shall specify the deviations which are to be made, the Lump-sum assessment or the proposed basis of payment, the extra time allowed, if any, and the date for completion of the entire contract.

Any objection by the Contractor to any matter concerning the order shall be notified by him in writing to the Engineer-in-charge within seven days from the date of such order, but under no circumstances shall the work be stopped (unless so ordered by the Engineer-in-charge) owing to differences or controversy that may arise from such an objection. In the absence such notification of objection by the contractor, he will be deemed to have accepted the order and the conditions stated therein. In the event of the contractor failing to agree with the Engineer-in-charge regarding the terms of the proposed deviation, the objection shall be referred to the Head of Civil Engineering Department whose decision shall be final, conclusive and binding on the contractor.

## **7. Time**

Time is the essence of the contract and is specified in the tender documents or in each individual Work Order.

As soon as possible after the contract is let or any substantial Work Order is placed and before work order is to begin, the Engineer-in-charge and the Contractor shall agree to a Time and progress Chart. The Chart shall be prepared in direct relation to the time stated in the tender documents or the Work Order for the completion of the individual items there of and the contract or order as a whole. It shall indicate the fore cast of the dates for the commencement of the various trade processes or sequence of the work, and shall be amended as may be required by agreement between the Engineer-in-charge and the Contractor within the limitation of the time imposed in the tender, document or order.

In the absence of any specific Time and Progress chart to be agreed to between the Contractor and Engineer-in-charge the contractor shall ensure and maintain uninterrupted progress of the work such that the entire work shall be completed within the time imposed in the Tender documents or Order and that the proportion of the work completed upto any time in relation to the entire work to be under the Contract or Order shall not be less than the proportion that the time elapsed bears to the total time of completion provided in the Tender documents or Order.

The Contractor shall suspend the execution of the work, or any part or parts thereof whenever call upon in writing by the Engineer-in-charge to do so, and shall not resume work there on until so directed in writing by the Engineer-in-charge. The Contractor will be allowed an extension of time for completion not less than the period of suspension. However, no other claim in this respect for compensation or otherwise however will be amitted. Provided the cause for suspension is not attributable to any default of the contractor's part to proceed with or fulfil the contractual obligations. This may also be extended to allow for alteration of work made by the deviation order.

## **8. Stores and Materials**

### **8.1 Materials to be supplied by the Contractor**

The Contractor shall at his own cost and expense provide all materials required for the work other than those listed in Schedule-B which are to be supplied by Bharat Heavy Electricals Ltd.

All materials to be provided by the Contractor shall be brand new and in conformity with the specifications laid down in the contract and the Contractor shall if requested by the Engineer-in-charge furnish proof, to the satisfaction of the Engineer-in-charge, that the materials so comply.

The Contractor shall at his own cost and expense and without delay, supply to the Engineer-in-charge samples of materials proposed to be used in the works. The Engineer-in-charge shall within seven days of supply of samples or within such further period as he may require and intimate to the Contractor in writing, inform the Contractor whether samples are approved by him or not. If samples are not approved, the Contractor shall forthwith arrange to supply to the Engineer-in-charge for his approval fresh samples complying with the specification laid down in the contract.

The Engineer-in-charge shall have full powers to require removal of any or all of the materials brought to site by the Contractor which are not brand new and not in accordance with the contract specifications or do not conform in character or quality to samples approved by him. In case of default on the part of the Contractor in removing rejected materials, the Engineer-in-charge shall be at liberty to have them removed by other means at the Contractor's expense and risk. The Engineer-in-charge shall have full power to require other proper materials to be substituted for rejected materials and in the event of the contractor refusing to comply, he may cause the same to be procured by other means. All costs charges and expenses which may attend such substitution shall be borne by the contractor. All charges on account of Octroi, terminal or sales tax and other duties on material obtained for the works from any source (excluding materials supplied by BHEL) shall be borne by the Contractor.

The Engineer-in-charge shall be entitled to have tests carried out as specified in the Contract for any materials supplied by the Contractor other than those for which, as stated above, satisfactory proof has already been furnished, at the cost of the Contractor and the Contractor shall provide at his expense all facilities which the Engineer-in-charge may require for the purpose.

## **8.2 Materials to be supplied by BHEL**

Materials which BHEL are prepared to supply are shown in Schedule-B which also stipulates place of issue and rate(s) to be charged in respect thereof soon after acceptance of the tender the Contractor shall agree in writing with the Engineer-in-charge on a phased programme of his requirements with regard to deliver of materials.

In the event of delay in supply of any Stores and materials mention in Schedule-B the contractor shall be entitled to reasonable extension of time as provided for under condition-9 but no claim for compensation or damage on any ground whatsoever shall be entertained by BHEL.

For the materials listed in Schedule-B the contractor shall give a reasonable notice in writing of his requirement to the Engineer-in-charge in accordance with the phased programme.

All materials issued to the Contractor by BHEL for incorporation or fixing in the works shall on completion or on fore-closure of the works and before submission of bills, be returned by the Contractor at his expense, at the place of issue, after making due allowance for actual consumption reasonable wear and tear and for waste. In the Contractor is required to deliver such materials at a place other than the place less the transportation charges which would have been incurred by the Contractor had such materials been delivered at the place of issue, shall be borne by BHEL.

The Contractor shall bear the cost of loading, transporting to site, unloading storing under covered area as necessary, assembling and joining the several parts together as necessary and incorporating or fixing materials in the work including all preparatory work of whatever description as may be required, and of closing preparing, loading and returning empty cases or containers to the place of issue.

If, in the opinion of the Engineer-in-charge (which shall be final and conclusive) any stores supplied by BHEL have either during currency of the work or after completion of the work whilst under custody, of the contractor, become damaged to such an extent that they cannot be usefully utilised, either in the same work or in other works, the Engineer-in-charge shall not accept the stores and in the rates specified in the contract. The contractor shall not be entitled to any claim whatsoever on this account.

The Engineer-in-charge shall have access to the stores where materials issued by BHEL as per schedule -B of the contract is stored to ensure the balance stock of material on hand after taking into consideration the materials used on the work is as per the issue and usage. If there be any discrepancy, the cost towards the same will be recovered at the double recovery rate indicated for the material concerned. This is without prejudice to and in addition to the overall reconciliation of materials to be made at the completion of work.

If on completion of works, the Contractor fails to return surplus materials out of those supplies by BHEL then, in addition to any other liability which the Contractor would incur, the Engineer-in-charge may, be written notice to the Contractor, require him to pay within a fortnight of receipt of the notice for such un-returned surplus materials given in sub para-4.

The Contractor shall have to build a weather-proof shed <sup>for</sup> or the storage of Cement (required for 15 days consumption of the work).

### 8.3 General

Materials required for the works, whether brought by the Contractor or supplied by BHEL shall be stored by the Contractor only at places approved by the Engineer-in-charge. Storage and safe custody of materials shall be at the risk and the responsibility of the Contractor.

Officials concerned with contract shall be entitled at any time to inspect and examine any materials intended to be used in or in the works either on the site or at factory or workshop or other places where such materials are assembled, fabricated or manufactured or at any place(s) where these are lying or from which these are being obtained and the Contractor shall give such facilities as may be required for such inspection and examination.

All materials brought to the site shall not be removed off the site without the prior written approval of the Engineer-in-charge. But whenever the works are finally completed and advance if any, in respect of any such materials is fully recovered the Contractor shall at his own expense forthwith remove from the site all surplus materials originally supplied by him and upon such removal the same shall revert in and become the property of the Contractor.

Should the Engineer-in-charge consider at any time during the construction or re-construction prior to the expiry of the MAINTENANCE PERIOD that the stores or materials provided by the Contractor are unsound or of a quality inferior to that contracted for or otherwise not in accordance with Contract (in respect where of the decision of the Engineer-in-charge shall be final and conclusive) the Contractor shall on demand in writing from the Engineer-in-charge specifying the Stores or materials complained of notwithstanding that the same may have been inadvertently passed, certified and paid for, forthwith remove the Stores or materials so specified and provide other proper and suitable stores or materials at his own expense, to the entire satisfaction of the Engineer-in-charge and in the event of his failing to do so within a period to be specified by the Engineer-in-charge in his demand aforesaid the Engineer-in-charge may replace with others the Stores or materials complained of at the risk and expense in all respects of the Contractor. The liability of the Contractor under this condition shall not extend beyond the maintenance period aforesaid except as regards Stores or materials which the Engineer-in-charge shall have previously given notice of to be Contractor to replace.

#### **9. Delay and Extension of Time**

If, in the opinion of Engineer-in-charge the work is delayed :

- i) by reason of abnormally bad weather, OR
- ii) by reason of serious loss or damage by fire OR
- iii) by reason of Civil commotion local combination of workmen, strike or lockout, affecting any of the trades employed on the work, OR
- iv) by delay on the part of the agency or tradesman engaged by BHEL in executing work not forming part of this Contract OR
- v) by reason of any other cause which in the absolute discretion of the Engineer-in-charge is (when he is the Accepting Officer of the Contract), beyond the Contractor's reasonable control, then in such cases the Accepting Officer, on the recommendation of the Engineer-in-charge or higher authority may make fair and reasonable extension in the completion dates of the individual items of work of the Contract as a whole. Such extension which will be communicated to the Contractor by the Engineer-in-charge in writing shall be final and binding on the Contractor. No other claim in this respect for compensation or otherwise howsoever is admissible. Upon the happening of any such event causing delay, the Contractor shall immediately give notice thereof in writing to the Engineer-in-charge but shall nevertheless use constantly his best endeavour to prevent or make good the delay and shall do all that may reasonably be required to the satisfaction of the Engineer-in-charge to proceed with the work.

#### **10. Patent Rights**

The Contractor shall fully indemnify BHEL or the agent, servant, employee of BHEL against any action, claim or proceeding relating to infringement or the use of any patent or design or any alleged patent or design rights, and shall pay any royalties which may be payable in respect of any article / or part thereof included in the Contractor. In the event of any claim, being made or action brought against BHEL or any agent, or servant or employee of BHEL in respect of the matters aforesaid, the Contractor shall immediately be notified thereof for taking necessary action provided that payment of indemnity shall not apply when such infringement has taken place in complying with the specific directions issued by the BHEL but the Contractors shall pay any royalties payable in respect of any such use.

#### **11. Octroi and Other Duties**

All changes on account of Octroi, Terminal or Sales Tax and / or other duties on materials obtained for the Work (excluding materials provided by BHEL on payment) shall be borne by the Contractor.

#### **12. Royalties**

Royalties fixed from time to time as per prevalent local rules will be recovered for materials, which the Contractor may be allowed to remove from quarries situated on land which is in charge of the BHEL authorities.

#### **13. Plant and Equipment**

The Contractor, shall at his own expense, supply all tools, plant and equipment (here-in-after referred to as T & P) required for the execution of the contract other than those listed in Schedule - C which subject to their availability may be hired by BHEL to the Contractor or issued free for use in the execution of the work, as specified in Tender documents.

#### **14. Assignments or Transfer of Contract**

The Contractor shall not without the prior written approval of the Accepting Officer assign or transfer the Contract or any part thereof, or any share, or interest there in to any other person. No sum of money which may become payable under the Contract shall be payable to any person other than the Contractor unless the prior written approval of the Accepting Officer to the assignment or transfer of such money is given.

#### **14 (a) Sub - Contract**

The Contractor shall not sub-let any portion of the Contract without the prior written approval of the Accepting Officer.

**15. Compliance to the Regulations and Bye - Laws**

The Contractor shall conform to the provision of any statute relating to the work and regulations and bye-laws of any local authority and of any water and lighting Companies or Undertakings with whose system the work is proposed to be connected. He shall, before making any variation from the drawings or the specifications that may be necessitated for such connections give the Engineer-in-charge notice, specifying the variation proposed to be made and the reasons there for and shall not carryout any such variation until he has received instructions from the Engineer-in-charge in respect thereof. The Contractor shall be bound to give all notice required by Statute Regulations of Bye-laws as aforesaid and to pay all fees and taxes payable to any authority in respect thereof.

**16. BLANK**

**17. BLANK**

## CHAPTER – III

### PERFORMANCE OF THE CONTRACT

#### 18. Security Deposit

18.1.1 Security Deposit should be collected from the successful tenderer. The rate of Security Deposit will be as below:

Upto Rs. 10 lakhs	10%
Above Rs. 10 lakhs up to Rs.50 lakhs	1 lakh+7.5% of the amount Exceeding Rs. 10 lakhs.
Above Rs. 50 lakhs	Rs.4 lakhs + 5% of the amount Exceeding Rs. 50 lakhs.

The security Deposit should be collected before start of the work by the contractor.

18.1.2 Security Deposit may be furnished in any one of the following:

- i) Pay Order, Demand Draft in favour of BHEL.
- ii) Local cheques of scheduled banks, subject to realization.
- iii) Securities available from Post Offices such as National Savings Certificates, Kisan Vikas Patras etc.  
(Certificates should be held in the name of Contractor furnishing the security and duly pledged in favour of BHEL and discharged on the back).
- iv) Bank Guarantee from Scheduled Banks / Public Financial Institutions as defined in the Companies Act subject to a maximum of 50% of the total security deposit value. The balance 50% has to be remitted either by cash or in the other form of security. The Bank Guarantee format should have the approval of BHEL.
- v) Fixed Deposit Receipt issued by Scheduled Banks / Public Financial Institutions as defined in the Companies Act. The FDR should be in the name of the contractor, A/C BHEL, duly discharged on the back.
- vi) Security deposit can also be recovered at the rate of 10% from the running bills. However in such cases at least 50% of the Security Deposit should be collected before start of the work and the balance 50% may be recovered from the running bills.
- vii) EMD of the successful tenderer shall be converted and adjusted against the security deposit.
- viii) The security deposit shall not carry any interest.

**NOTE:** Acceptance of Security Deposit against Sl. No. (iv) and (vi) above will be subject to hypothecation or endorsement on the documents in favour of BHEL. However, BHEL will not be liable or responsible in any manner for the collection of interest or renewal of the documents or in any other matter connected therewith.

**CONTRACTOR**

- 18.1.3** Security deposit shall not be refunded to the contractor except in accordance with the terms of the contract.
- 18.1.4** All compensation or other sums of money payable by the contractor to BHEL, under the terms of this contract or under any other contract with BHEL, may be deducted from the security deposit or realized by the sale of the securities or from the interest arising there from or from any sums which may be due or may become due to the contractor payable by BHEL on any account whatsoever against this contract or any other contract with BHEL, and in the event of his security deposit being reduced by reason of such deduction or sale as aforesaid, the contractor shall within seven days thereafter make good in cash or in securities endorsed as aforesaid, any sum or sums by which the security deposit has been so reduced.
- 18.1.5** 50% of the security deposit may be refunded on completion of the work after payment of the final bill and the balance 50% of the security deposit is refundable only after the expiry of the maintenance period of six (6) months from date of completion of work as stipulated in the contract concerned.

## **19. Orders under the Contract**

All orders, notices, etc., to be given under the contract shall be in writing, typescript or printed and if sent by registered post to the address given in the tender of the Contractor, shall be deemed to have been served on the date when in the ordinary course they would have been delivered to him.

The Contractor shall carry out without delay all orders given to him.

## **20. Admission to Site**

The contractor shall not enter on (other than for inspection purposes) or take possession of the site unless permitted to do so by the Engineer-in-charge. The portions of the site to be occupied by the Contractor will be clearly defined and marked on the site plan, and the contractor will on account be allowed to extend his operations beyond these areas. The Contractor shall provide if necessary or required at the site, temporary access there to and shall alter, modify and maintain the same as required from time to time. He shall out and clear away the access route when no longer required restoring the area to its original condition.

The Engineer-in-charge shall have power to execute other works (whether or not connected with the work, in the contract agreement) on the site contemporaneously with the execution of the original work and contractor shall give reasonable facilities for this purpose.

BHEL reserves the right of taking over, at any time, any portion of the site which they may require and the contractor shall at his own expense clear such portion forthwith. No photographs of the site or of the work or any part here of shall be taken published or otherwise circulated without the prior approval of the Engineer-in-charge.

No such approval shall ~~however~~ <sup>however</sup> exempt the Contractor from complying with any statutory provision in regard to the taking and publication of such photographs.

BHEL Officials connected with the Contract shall have the right of entry to the site at all times.

Engineer-in-charge shall have the power to exclude from the site any person whose admission there to may, in his opinion be undesirable for any reason whatsoever

The Contract shall be governed by the security regulations of BHEL including the entry exit timings, use of roads as may be in force from time to time. The Contractor should follow these regulations strictly and no claims for any additional payment whatsoever will be entertained under by circumstances.

## 21. Contractors Supervision

The Contractors shall either himself supervise the execution of the Contractor or shall appoint a competent Agent approved by the Engineer-in-charge to act in his stead. The Contractor shall employ an Engineer/Agent having atleast a Degree of Bachelor of Civil Engineer from a recognised University/on any work with a Contract value exceeding rupees two lakhs, and having atleast a Diploma in civil Engineering from a recognised college, on work with a contract value exceeding Rs. 50,000/- but not exceeding rupees two lakhs.

The Employment of an Engineer/Agent as aforesaid shall not be necessary if the Contractor himself is in possession of a recognised technical qualification and is, in opinion of the Engineer-in-charge, capable of the receiving instructions of the Engineer-in-charge and of the executing the work to the satisfaction of the Engineer-in-charge. If the Contractor fails to appoint a suitable Engineer/Agent as aforesaid, the Engineer-in-charge shall have full powers to suspend the execution of work and stop payment of any advances that may have become due until such date as a suitable Engineer/Agent is appointed and the Contractor shall be held responsible for the delay caused to the work and no extension of time on this account shall be given to him as stipulated in condition (9) above.

Orders given to the Contractor's Agent Engineer shall be considered to have the same force as if they had been given contractor himself.

The Contractor or his Agent shall be in attendance at the site during all working hours and shall superintend the executing of work with such additional assistance in each trade as the Engineer-in-charge may consider necessary.

The Contractor or his accredited agent shall attend when required and without making any claim for doing so, either the Office of the Engineer-in-charge or the work site to receive instructions.

The Engineer-in-charge shall have full powers, and without assigning any reason to require the Contractor immediately to cease to employ in connection with the

Contract any Agent, servant or employee whose continued employment is, in his opinion undesirable

The contractor shall not be allowed any compensation on this account.

## **22. Labour**

The contractor shall employ labour in sufficient number either directly or through sub-contractors to maintain the required rate of progress and of quality ensure workmanship of the degree specified in the contract and to the satisfaction of the Engineer-in-charge. The contractor shall comply with all labour laws in force from time to time.

## **23. Safety Rules**

The Contractor shall comply with all safety rules of BHEL.

## **24. Water**

The Contractor shall allow in his Tender and provide at his cost all water required for the work or his employees on the work, together with all pipes and fittings or other means that may be necessary or required to ensure a proper and ample supply of water for all purposes connected with the work.

In the event of a provision existing in the Tender documents for supply of water on payment by Bharat Heavy Electricals Limited, water will be supplied from the BHEL supply system or other sources at any points fixed by the Engineer-in-charge on the site of work. The contractor shall make necessary arrangement for lifting pumping carrying or conveying the water as required at his own cost. The levy of water charges to be borne by the contractor in such case shall be specifically mentioned in the Tender documents.

## **25. Temporary workshops, store Etc,**

The Contractor shall, during the progress of the work provide, erect and maintain at his own expense all necessary temporary workshops, offices etc., required for the proper and efficient execution of the work. The planning, siting, and erection of these buildings shall have the approval of the Engineer-in-charge and the Contractor shall all at times keep them tidy and in a clean and sanitary condition to the entire satisfaction of the Engineer-in-charge.

On completion of the work all such temporary building shall be cleared away and the site restored and left in a clean and tidy condition to the entire satisfaction of the Engineer-in-charge.

## **26. Tool and Plant on site**

All tools, plant and equipment brought to the site shall not be removed from the site without the prior written approval of the Engineer-in-charge when the work is finally completed or the contract is determined for reasons other than the default of the contractor he shall forthwith remove from the site all tool, plant, equipment etc., (other than those as may have been provided by BHEL)

## **27. Statments of Hire Charges**

A monthly detailed statement of the hire charge incurred in respect of BHEL tools, plant, equipments etc., shall be given to the Contractor by the Engineer-in-charge.

## **28. Precaution Against risks**

The Contractor shall be responsible for providing at his own expense, for all precaution to prevent loss or damage and for the necessary steps to be taken for the said purpose until the works have been handed over complete, in all respects to the Engineer-in-charge.

The Contractor shall provide all watchman necessary for the protection of the site, the work, the materials, tools, plant, equipment and anything else lying on the site during the progress of the work. He shall solely be responsible for and shall take all reasonable and proper steps for protecting, securing, lighting and watching all places on or about the work and the site which may be dangerous to any person whomsoever.

## **29. Notices and fees**

The Contractor shall give all notices required by any Statutory provision or by the regulations and/or bye-laws of any local / or of any same are or will be connected. The contractor shall pay and indemnify BHEL against any statutory fees and charges payable under such Acts. Regulation and / or bye-laws in respect of the work and shall make and supply all drawings and plans required in connection with any such notice.

## **30. Setting out of the works and Protective and Maintaining signals and works**

The Engineer-in-charge shall supply dimensioned drawings, levels and other information necessary to enable the contractor to set out the work. the contractor shall at his own expense set accurately according to the drawings and figured dimension thereon, all the work comprised in the contract and any extras or additions there to and shall be solely responsible for their being so set out and executed.

All bench marks, pegs, signals on the surface alignment stones, milestones and all similar marks whether put in by BHEL Authorities for the purpose of checking the Contractor's work or in the nature of permanent survey marks will during the tenure of the contract, be under the care of the Contractor who shall at his own expense take all proper and reasonable precautions and care to preserve and maintain them in their true position. In the event of these marks being disturbed or obliterated by accident or due to any other cause whatsoever, the same may, if deemed necessary be replaced by the Engineer-in-charge at the Contractor's expense and the cost thereof deducted from any money then or thereafter becoming due to the Contractor.

Where requested by the Contractor, the level marks, centre line and chainage pegs corresponding to those shown on the Drawing will be pointed out to the Contractor on the ground but all bench marks or chainage pegs additional to those shown on the Drawing will be set out by BHEL authorities.

### **31. Site Drainage**

All water that may accumulate on the site during the progress of the work, or in trenches and excavations shall be removed to the entire satisfaction of the Engineer-in-charge and at Contractor's expense.

### **32. Excavation, Relics, etc.**

Materials of any kind obtained from excavation on the site shall remain the property of BHEL and shall be disposed off as Engineer-in-charge directs.

All gold, silver, oil and other minerals of any description and all precious stones coins treasures, relics, antiquities and other similar items which may be found in or upon the site shall be the property of Bharat Heavy Electricals Limited and the contractors shall duly preserve the same to the satisfaction of the BHEL and shall from time to time deliver the same to such person or persons as the BHEL may appoint to receive the same.

### **33. Foundations**

The Contractor shall not lay any foundations until the excavations for the same have been examined and approved in writing by the Engineer-in-charge.

### **34. Covering - in work**

The Contractor shall give reasonable notice in writing to the Engineer-in-charge whenever any work is to be permanently covered up or concealed, whether by earth or other means so that it can finally be inspected or measured, if necessary. In default of so doing, the Contractor shall if required by the Engineer-in-charge uncover such work at his own expense.

### **35. Approval of Works by Stages**

All work embracing more than one process shall be subject to examination and approval at each stage thereof and the Contractor shall give due notice in writing to the Engineer-in-charge when each stage is ready. In default of such notice being received, the Engineer-in-charge shall be entitled to approve the quality and extent thereof at any time he may choose and in the event of any dispute, the decision of the Engineer-in-charge thereon shall be final conclusive.

### **36. Execution of the work**

The work shall be executed in a workman like manner and to the satisfaction in all respects of the Engineer-in-charge.

The Engineer-in-charge will communicate or confirm his instructions to the Contractor in respect of the execution of the works in a "Work Site Order Book" maintained at his office and the Contractor shall visit this office daily and shall confirm receipt of such instruction by signing the relevant entries in this book. Such entries will rank as order to notices in writing the intent and meaning of these conditions.

### **37. Day Work**

No day - work shall be performed without the prior written instructions of the Accepting Officer.

The Contractor shall give to the Engineer-in-charge reasonable notice of the start of any work ordered to be executed by day-work and shall deliver to the Engineer-in-charge within two days of the end of each pay week a return in duplicate giving full detailed accounts of labour and materials for the payweek. One copy of each of these returns, if found correct will be certified by the Engineer-in-charge and returned to the Contractor and must be produced at the time of adjustment of accounts.

An Invoice in duplicate signed by the Contractor or his agent shall be sent with each delivery of materials for day-work and the Contractor will be furnished with receipt signed by the Engineer-in-charge specifying the description, quantities, weight or measurement (as the case may be) of the articles approved, reference will be made in this receipt in the return aforesaid and the Contractor's Bill.

In the case of Lumpsum Contracts, the rates to be charged and the percentage addition for profit and establishment charges etc. will be agreed upon between the Accepting Officer and the Contractor prior to the execution of the work.

### **38. Inspection of the Work**

BHEL Officers concerned with the contract shall have power at any time to inspect and examine any part of the work and the Contractor shall give such facilities as may be required to be given for such inspection and examination.

Should Engineer-in-charge consider, at any time during the expiry of the maintenance period, that any work has been executed with unsound, imperfect or unskilled workmanship or of a quality inferior to that contracted for or not otherwise in accordance with the contract (in respect). Whereof the decision of the Engineer-in-charge shall be final and conclusive the contractor shall, on demand in writing from the Engineer-in-charge specifying the fault notwithstanding that the same may have been inadvertently passed, certified and paid for, forthwith rectify or removed and reconstruct the work so specified in whole or in part as the case may require at his own expense to the entire satisfaction of the Engineer-in-charge and in the event of his failing to do so within a period to be specified by the Engineer-in-charge in his demand as aforesaid, the Engineer-in-charge whose decision shall be final and binding may carry out the work by other means at the risk and expense in all respects of the Contractor. However, the liability of the Contractor under this condition shall not extend beyond the maintenance period except as regards workmanship which the Engineer-in-charge shall have previously given notice of to the Contractor to rectify.

### **39. Responsibility for Building**

In the event of any building or part of any building being handed over to the Contractor for the execution of work there to under the provisions of the Contract he shall give a written receipt for all fixtures, glass etc., and he shall be required to make good at his own expense all damages resulting from the cause whatsoever while in his charge and on completion of the work to deliver the said building or part

thereof in a clean state complete in every particular to the entire satisfaction of the Engineer-in-charge.

#### **40. Insurance**

The Contractor shall within one month after the date of acceptance of the Contract, insure the work against loss or damages to the contract works, temporary work and materials erected in performance of the contract "all risks" basis from the time of arrival on site until taken over by BHEL on completion of the Contract.

The cover shall also include whenever necessary the risks of testing including breakdown or explosion of plant and machinery undergoing testing, trial and commissioning operations. The insurance shall also specifically cover removal of debris cost. The sum insured shall represent the estimated full value of the contract work inclusive of value of free supply materials by BHEL, transport charges, customs dues, express freight, overtime charges, cost of erection, value of constructional plants and machinery; removal of the debris and excavation of costs. Where the contract includes a maintenance period, the insurance cover shall specifically include the Contractor's liabilities during the maintenance period. The insurance shall also be extended to cover third party personal injury and property damage for a sum to be specified by BHEL. The insurance shall be effected in the name of BHEL and the Contractor shall submit to BHEL a draft of the insurance policy for approval. The policy when issued will be lodged with BHEL together with receipts of premium for such insurance and the contractor shall maintain such policies in force until the obligations of the Contractor are fully discharged.

If the Contractor fails to comply with the terms of this condition the Accepting Officer may insure the work and may deduct the amount of premiums from any money that may become payable to the Contractor or may at his discretion refuse payment of any advances to the Contractor until the Contractor shall have complied with the terms of this condition. This provision does not, however, absolve the Contractor of his responsibility for taking up the insurance. The Contractor is, therefore, primarily responsible for the insurance in time.

#### **41. Damage and Loss to Private Property and Injury to Workmen**

The Contractor shall at his own expense reinstate and make good to the satisfaction of the Engineer-in-charge and pay compensation for any injury, loss or damage occasioned to any property or rights whatever including property and rights of BHEL (or agents, servants or employees of BHEL) the injury loss or damage arising out of or in any way in connection with the execution of the contract and further the Contractor shall indemnify BHEL against all claims enforceable against BHEL or any agent, servant, or employee of BHEL a private person, in respect of any such injury (including injury resulting in death loss or damage to any person) who so ever or property, including all claims which may arise under the Workmen's Compensation Act or otherwise, or which would be enforceable against BHEL.

#### **42. Completion**

The works shall be completed to the entire satisfaction of the Engineer-in-charge and in accordance with the Contractor's forecast of Time and progress where operative, and all unused stores and materials, tools, plants equipment, temporary Building and things shall be removed from the site and work cleared of rubbish and all

waste materials and levelled up clean and tidy to the satisfaction of the Engineer-in-charge at the Contractor's expense and/or before the Schedule date of completion.

The BHEL shall have power to take over from the Contractor from time to time such sections of the Work as have been completed to the satisfaction of the Engineer-in-charge. In such an event, the contractor is not entitled for any extension of time or any other compensation for executing the balance work.

In case the Contractor fails to remove any of his properties, assets or fails to clear the rubbish and waste materials within 30 days of the completion of the contract, it is lawful for the contractee, that is BHEL to take such action as it deems fit to clear, dispose of such properties, assets or such waste materials and charge the Contractor any expenses incurred thereon.

The Engineer-in-charge shall certify to the Contractor the date on which the work is completed and the state thereof.

The Engineer-in-charge shall also certify to the Contractor the state of the work at the end of maintenance period, where applicable.

#### 43. Compensation for delay

If the Contractor fails to maintain the required progress in terms of condition 7 or to complete the work and clear the site on or before the contracted or extended period of completion, he shall, without prejudice to any other right or remedy of the BHEL on account of such breach pay as agreed compensation an amount calculated as stipulated below or such smaller amount as may be fixed by the BHEL on the contract value of the work for every week that the progress remains below that specified in condition 7 or that the work remains incomplete.

This will also to items or groups of items for which separate period of completion has been specified.

For the purpose the term "Contract Value" shall be the value at contract rates of the work or ordered.

- |                                                                                              |                        |
|----------------------------------------------------------------------------------------------|------------------------|
| a) Completion period (as originally stipulated) not exceeding 6 months                       | at 1 per cent per week |
| b) Completion period (as originally stipulated) exceeding 6 months and not exceeding 2 Years | at ½ per cent per week |
| c) Completion period (as originally stipulated) exceeding 2 years                            | at ¼ per cent per week |

Provided always that the total amount of compensation for delay to be paid under this condition shall not exceed the under noted percentage of the contract value or of the item or group of items of work for which a separate period of completion is given :

- |                                                                                                       |             |
|-------------------------------------------------------------------------------------------------------|-------------|
| a) <sup>Completion</sup> <del>Complete</del> period (as originally stipulated) not exceeding 6 months | 10 per cent |
|-------------------------------------------------------------------------------------------------------|-------------|

- |                                                                                              |             |
|----------------------------------------------------------------------------------------------|-------------|
| b) Completion period (as originally stipulated) exceeding 6 months and not exceeding 2 Years | 7½ per cent |
| c) Completion period (as originally stipulated) exceeding 2 years                            | 5 per cent  |

The amount of compensation may be adjusted or set-off against any sum payable to the contractor under this or any other contract with the BHEL.

#### 44. Laws Governing the Contract

This Contract shall be governed by the Indian Laws for the time being in force.

#### 45. Cancellation of Contract for Corrupt Acts

The Accepting Officer, whose decision shall be final and conclusive, shall without prejudice to any other right or remedy which shall have accrued or shall accrue thereafter to Bharat Heavy Electricals Limited, cancel the Contract in any of the following cases and the contractor shall be liable to make payment to BHEL for any loss or damage resulting from any such cancellation for default. If the Contractor shall :

- a) Offer or give or agree to give to any person in BHEL service any gift or consideration of any kind as an inducement or reward for doing or for bearing to do or for having done or forborne to do a day act in relation to the obtaining or execution of this or any other contract for BHEL service OR
- b) Enter into a contract with BHEL in connection with which commission has been paid or agreed to be paid by him or with his knowledge, unless the particulars of any such commission and the terms of payment thereof have previously been disclosed in writing to the Accepting Officer, OR
- c) Obtain a contract with BHEL as a result of ring tendering or by non-bonafide methods of competitive tendering without first disclosing the fact in writing to the Accepting Officer.

#### 46. Cancellation of Contract for Insolvency, Assignment or Transfer or Sub-Letting of Contract

The Accepting Officer, without prejudice to any other or remedy which shall accrue thereafter to BHEL shall cancel the contract in any of the following cases :

If the Contractor

- a) being an individual, or if a firm any partner thereof shall at any time be adjudged bankrupt or have a receiving order or orders for administration, of his Estate made against him or shall take and proceedings, for liquidation or composition under any Bankruptcy Act for the time being in force or make any conveyance of assignment of his effects composition or arrangement for the benefit of his credit or purport to do so, or if any application be made under any Bankruptcy Act for the time being in force for sequestration of his Estate or if a trust deed be granted by him on behalf of his creditors, OR

- b) being a company shall pass a resolution or the court shall make an order for the liquidation of its affairs, or a Receiver or Manager on behalf of the debentures holders shall be appointed or circumstances shall arise which entitle the court or debentures holders to appoint a Receiver or Manager OR
- c) assigns, transfer, sub-lets or attempts to assign, transfer or sub-let any portion of the work without the prior written approval of the Accepting Officer OR
- d) Shall suffer an execution being levied on his goods and allow it to be continued for a period of 21 days.

Whenever the Accepting Officer, exercises his authority to cancel the contract under this condition, he may complete the work by any means at the Contractor's risk and expense provided always to that in the event of the cost of completion (as certified by Engineer-in-charge which is final and conclusive) being less than the contract cost, the advantage shall accrue to the BHEL and that if the cost of completion exceeds the moneys due to the Contractor under the contract, the contractor shall either pay the excess amount ordered by the Engineer-in-charge or the same shall be recovered from the Contractor by other means.

Engineer-in-charge will have powers to take possession of the site and any materials constructional plant, implements, stores, etc. thereon and carry out the work by any means at the risk and cost of the Contractor.

In case the BHEL completes the work under the provisions of this condition the cost of such completion to be taken into account in determining the excess cost to be charged to the contractor under this condition shall consist of the cost of materials purchased and or labour provided by the BHEL with an addition of such percentage or cover superintendence and establishment charges as may be decided by the General Manager whose decision shall be final and conclusive.

In the Contractor fails to pay the excess sum within a period of 30 days, the Engineer-in-charge shall have the right to sell any or all of the Contractor's unused materials, constructional plant implements, temporary buildings etc. and apply the proceeds of sale thereof towards the satisfaction of any sum due from the Contractor under the contract and if thereafter be any balance outstanding from the Contractor, it shall be recovered in accordance with the provisions of the Contract.

#### **47. Cancellation of contract in part or Full for Contractor's Default**

If the contractor :

- a) makes default in commencing the within a reasonable time from the date of handing over of the site and continue in that state a reasonable notice from Engineer-in-charge OR
- b) in the opinion of the Engineer-in-charge at any time, whether before or after the date extended date for completion, make default in proceeding with the work, with due diligence and continue in the state after a notice of seven days from Engineer-in-charge OR
- c) fails to comply with any of the terms and conditions of the contract or after 7 days notice in writing with orders properly issued thereunder. OR

- d) fails to complete the work order and items of work individual dates for completion and clear the site on or before the date of completion or fails to achieve the progress at set out under clause 7 of these General conditions of contract.

The Accepting Officer may, prejudice to any other right or remedy which shall have accrued or shall accrue after B H E L, Cancel the contract as a whole or in part there or only such work order items of work in default from the contract. Whenever the Accepting officer exercises his authority to cancel the contract as a whole or in part under this condition he may complete the work at the contractor's risk and cost provided always that in the event of the cost of completion (as certified by Engineer-in-charge which is final and conclusive) being less than the contract cost the advantage shall accrue to the BHEL if the cost of completion exceeds, the money due to the contractor under this contract the contractor shall either pay the excess amount ordered by General Manager or the same shall be recovered from the contractor by other means. Engineer-in-charge will have power to take possession of site and materials, constructional plant, implements, stores etc there on.

In case the BHEL completes the work or any part there of under the provisions of the condition the of such completion to be taken in to account in determining the excess cost to be charged to the contract under this condition shall consist of the cost of materials purchased and / or labour provided by the BHEL. with an addition of such percentage to cover superintendance and establishment charges as may be decided by the General Manager whose decision shall be final and conclusive.

If the contract fails to pay the excess sum within a period of 30 days the Engineer-in-charge shall have the right to sell any or of the contractor's unused materials, construction plant, implements, temporary buildings etc and apply the proceeds of sale there of towards the satisfaction of any sum due from the contractor under the contract and if <sup>there</sup> ~~not~~ after be any balance out-standing from the contract, it shall be recovered in accordance with the provisions of the contract.

#### 48. Termination of Contract for death

Without prejudice to any of the rights or remedies under this contract. if the contractor dies, the Accepting officer shall have the option of terminating the contract without compensation to the contractor.

#### 49. Special Powers of Determination

If at any time after the acceptance of the tender BHEL shall for any reason whatsoever not require the whole or any part of the work to be <sup>carried out</sup> ~~done~~ General Manager shall give notice in writing of the fact to the contractor who shall have no claim to any payment of compensation or otherwise howsoever on account of any profit or advantage which he might have derived from the execution of the work in full but which he <sup>did</sup> ~~did~~ not derive in consequence of the foreclosing of the work.

He shall be paid at contract rates for the full amount of the executed including such additional works, e, g. clearing of site, etc., as may be rendered necessary by the said foreclosing. He shall also be allowed a reasonable payment (as decided by the Accepting office) for any expenses sustained on account of labour and materials collected but which could not be utilised on the work, as verified by the Engineer-in-charge. Neither shall the contractor have any claim for compensation on account of any alterations have been made in the original specifications drawings, designs and instructions, involving any curtailment of the work as original contemplated.

**50. BLANK**

## CHAPTER - IV

### VALUATION AND PAYMENT

#### 5). Records and Measurements :

All items having a financial value shall be entered in the BHEL Measurement Book so that a complete record is obtained of all works performed under the contract.

Buildings, etc., priced in schedule 'A' as a unit Lump-sum will be entered by number at the unit Lump-sum.

Work carried out for agreed Lump-sum will be described and similarly recorded.

Lump-sum omissions will be entered for deduction. Measurement shall be restricted to that required to ascertain the financial liability of BHEL under the contract.

Work which fails to be measured in detail shall be measured physically, without reference to any local custom that may obtain excepting where it may otherwise be directed in the tender documents. The measurements shall be taken jointly by any person duly authorised on the part of the BHEL and by the contractor.

The engineer-in-charge shall give reasonable notice in writing to the contractor of appointment of measurement.

The contractor shall without extra charge, provide assistance with appliance and other things necessary for measurement.

The contractor shall bear all the cost of measurements of his work.

measurements shall be entered in the BHEL measurement book and signed and dated by both parties each day at the site on completion of measurement. If the contractor objects to any of the measurements recorded on behalf of the BHEL. A note to that effect to be made in the BHEL measurement book or against the item or items objected to; and such note shall be signed and dated by both the parties engaged in taking the measurement.

If as a result of such objection, it becomes necessary to re-measure the work wholly or in part, the expense of such measurement shall be borne by the party requiring the measurement.

Measurement to be re-taken provided that a net error is found by this re-measurement to amount to less than 5% (Five percent) of the value as recorded by the first measurement. But where the net errors amount to 5% and over of the said value, then the cost is to be borne by the other party. In any case if the net value of errors found exceeded to Rs 500 the expense or re-measurement is said to be borne by the other party. If the contractor's representative fails to attend when required, the engineering-in-charge shall have power to proceed by himself to take measurement and in that case those measurements shall be considered as accepted by the contractor as final. The contractor shall, once in every month, submit to the engineer-in-charge with a copy to the accepting officer details of his claims for the work done by him up to and including the previous month which are not covered by his contract agreement in any of the following respects.

- a) Deviation from the items and specifications provided in the contract documents.
- b) Extra Items / Items of work.
- c) Quantities in excess of those provided in the contract schedule.
- d) Items in respect of which rates have not been settled. He should, in addition furnish a clear certificate to the effect that the claims submitted by him as aforesaid cover all his claims and that no further claims shall be raised by him in respect of work done up to and including the period under report.

Except where any general to detailed description of the work in quantities expressly shows to contrary, schedule of quantities shall be deemed to have been prepared and measurements shall be taken in accordance with the procedure set forth in the schedule of rates specification not withstanding any provision in the relevant standard method of measurement or any general or local custom. In the case of items which are not covered by the schedule of rates / specification, measurement shall be taken in accordance with relevant standard method of measurement issued by the Indian Standard Institution or as per Standard engineering practice.

## **52 Valuation of Deviations**

Rates for deviated items of work will be fixed as follows :

- 1) For any item of work required to be carried out after the contract has been awarded and which is not covered by Contractor's Schedule but is covered by B.H.E.L. schedule of Rates the payable for such a fresh item will be derived from B.H.E.L. Schedule by the method of proportion as follows:
  - a) In the same proportion to the BHEL Schedule of rates as the tendered rate for the nearest analogous item of work in contractor's schedule bears to rate for the particular analogous item of work in BHEL schedule of rates. However in case of nearest analogous item of work in contract schedule forms part of individual chapter of the BHEL schedule of rates the above proportion will be worked out only for such items which are found both in contract schedule and BHEL Schedule of rates as group of items under the chapter.
  - b) If a single appropriate analogous item of work is not available in both schedule (contractor's and BHEL schedule) then the method of proportion will be applied to the nearest analogous group items available in both the schedule referred to i.e. in the same proportion as the total tendered cost of that particular group of item (the sum of the products of the tendered rates and the quantities for which orders are placed ) bears to the total cost of the same items and quantities and BHEL Schedule of Rates.
  - c) If even an appropriate analogous group of items is not available in contractor's schedule and BHEL Schedule, then the methods of proportion will be applied to all those items of the whole work, which are available in both the schedule and for which orders have been placed on the contractor i. e., in the same proportion as the total cost of all

these items of work (the work of the products of the tendered rates and the quantities for which order are placed) bears to the total cost of the same items and quantities at the BHEL schedule of rates.

The selection of analogous items or analogous group of items referred to above shall be done by the Engineer-in-charge. Where the rates for deviated items or new items of work can be derived by the selection of different analogous items or analogous group of items, the lowest of all such derived rates shall be taken as the correct rate.

In the case of the contracts for which the Engineer-in-charge is the Accepting officer all disputes regarding the settlement of rates of deviated or new items or work shall be referred to the Head of Civil Engineering Department whose decision shall be final and conclusive as the case may be.

II. If any work not covered by any of the foregoing is ordered of the contractor, the basis of payment shall be decided by the Accepting Officer whose decision shall be final and conclusive and binding on the parties.

### **53. Reimbursement / Refund on variation in Price, Materials**

If after submission of the tender and / or during the progress of the works, the price of any material (not being a material supplied from the BHEL store in accordance with the conditions of the contract) is increased or decreased by an Act of Legislature (central or state) and / or any notification thereunder or on account of new duties or levies such as octroi or on account of increase or decrease in such duties affecting the price of materials required for incorporation in the works and made from materials of which the price has increased or decreased as aforesaid and the contractor has thereupon to pay in respect of such material or item a price which is higher or lower than the price of that material or item as prevailing immediately before the passing of such act or levying, increasing / decreasing of such duty, the BHEL shall increase in price or the duty reimbursed to the contractor the increase in price or additional or increased duty paid by the contractor and in case of decrease in price the BHEL shall be entitled to a refund of the reduction in the price or the reduction in duty. This will be applicable only for material which are directly incorporated on the work. The contractor shall however indicate the assumption he has made while submitting the tender. However no reimbursement or refund shall be made if the increase / decrease is not more than + 10% of the said price, and if so the reimbursement or refund shall be made only / on the excess over  $\pm$  10% provide always that any such increase shall not be payable if, in the opinion of the Accepting officer (whose decision shall be final and conclusive) the increase is attributable to the delay in the execution of the contract with the control of the contractor or that any such increase has become operative after the contracted/ or extended date of completion of the works or items of work in question.

The Contractor shall, for the purpose of this condition, keep such books of account and other documents as are necessary to show the amount of any increase or any reduction available and shall allow inspection of the same by any duly authorised representative of the BHEL and further shall at the request of the Engineer-in-charge furnish for verification such other information as the Engineer-in-charge may require.

The Contractor shall within a reasonable time of his becoming, aware of any alteration in the prices of any such materials give notice thereof in writing to the Engineer-in-charge stating that the rate is submitted in pursuance to this condition together with all information relating thereto which he may be in a position to supply.

#### **Advance on account**

No payment shall be made for work estimated to cost less than Rupees ONE THOUSAND till after the whole of the work shall have been completed and a certificate of completion given by the Competent authority.

In the case of work estimated to cost more than Rupees FIVE THOUSAND the contractor may at intervals of less than one month or as otherwise provided for in the Contract documents, counting from the date on which order to commence work is given by Engineer-in-charge submit claims on BHEL forms for payment of advances on account of work done and of materials delivered in connection with the Contract.

The Contractor shall be paid in respect of such claims to the extent approved and passed by the Engineer-in-charge subject to a maximum of 90% of the value of the work actually executed to the satisfaction of the Engineer-in-charge. The certificate of the Engineer-in-charge regarding such approval and passing of the sums so payable shall be final and conclusive against the contractor.

#### **Notes :**

"After the full amount of Security Deposit is made up through the 10% deduction from On account bills, 100% payment of all subsequent bills may be made to the contractor.

The Contractor may also be paid during the progress of the work 75% of the value of any materials which are in the opinion of the Engineer-in-charge in accordance with the Contract, and are actually required for incorporation in the work and which have reasonably been brought to the site in connection there with and are adequately stored and / or protected against damage by weather or other, causes, but which have not at the time of payment of the advance been incorporated the work on furnishing a formal hypothecation deed. Payment of such advances, however shall be purely at the discretion of the Accepting Officer provided always that payment shall not be made under these periodical certificate in respect of materials like lime, cement, timer, sand, kankar, etc.

Any sums, due from the Contractor on account of Tools and Plant, stores or any other items provided by BHEL shall be deducted from the respective advances. The Engineer-in-charge shall from time to time certify the sums payable to the Contractor after retaining the reserves.

Any certificate relating to work done or materials delivered may be modified or corrected by any subsequent interim certificate or by the final certificate of the Engineer-in-charge supporting an advance payment shall itself be conclusive evidence that any any work or materials it relates are in accordance with the contract. All such intermediate payments shall be regarded as advance against the final payment only and shall not be considered an admission of the performance of the contract or any part thereof in any respect or the accruing of any claim whatsoever.

Such intermediate payment shall not conclude determine or affect in any way the powers of the Engineer-in-charge as to the final settlement and adjustment or the account or otherwise or in any way vary or affect the contract.

#### **55. Final Bill**

As soon as possible after the completion of the work to the satisfaction of the Engineer-in-charge, the contract shall forward a certified final account on BHEL forms, in duplicate.

It shall be accompanied by all abstracts, vouchers, etc., in support thereof and shall be prepared in the manner prescribed by the Engineer-in-charge.

No claims will be entertained after the receipt of the final bill.

The Contractor shall be entitled to be paid the final sum less the value of payments already made on account, subject to certification of the final bill by the Engineer-in-charge. Any sums due from the Contractor on account of Tools and Plant, Stores or any other items provided by BHEL not yet recovered from the contractor shall be deducted from the final sum aforesaid.

No charge shall be allowed to the Contractor on account of the preparation of the final bill.

#### **56. Payment of Bills**

All payment to be made to the Contractor under this contract shall be by "Crossed Cheque" marked "A/c payee only" (within a reasonable time after the certification by the Engineer-in-charge) at the Nationalised Banks/Scheduled banks or their subsidiaries located in the station where either the work is executed or service rendered or at their branch nearest to the station where the Office of the Engineer-in-charge is located.

#### **57. Recovery from Contractor**

Whenever under the contract any sum of money shall be recovered from or payable by the Contractor the same may be deducted any sum then due or which at any time thereafter may become due to the Contractor under the contract or under any other contract with BHEL or from his Security Deposit or he shall pay the claim on demand.

#### **58. Post Technical Audit of work and Bills**

BHEL reserve the right to carry out a post-payment audit and technical examination of the work and final bill including all supporting vouchers, abstracts etc., and to enforce recovery of any sums becoming due as a result thereof in the manner provided in the preceding sub-paragraphs provided. However, no such recovery shall be enforced after three years of passing the final bill.

#### **59. Refund of Security Deposit**

50% of the Security deposit mentioned in condition 18 above, may be refunded to the Contractor in respect of all contract on completion of work and after payment of final bill and the balance 50% on expiry of the maintenance period, provided the

Contractor shall have rendered a "No - Demand" Certificate. In case of work where maintenance period is not involved 100% of the Security Deposit may be refunded after payment or final bill provided that the Contractor shall have rendered a "No Demand" Certificate.

## **60. Arbitration**

Except where otherwise provided for in the contract all questions and disputes relating to the meaning of the specifications, designs, drawings and Instructions herein before mentioned and as to the quality of workmanship or materials used on the work or as to any other question, claim matter or thing whatsoever in any way arising out of or relating to the contract, designs, drawings, specifications, estimates, instructions, orders or there conditions or otherwise concerning the work or failure to execute the same whether arising during the progress of the work or after the completion or abandonment thereof shall be referred to the sole arbitration of the General Manager of BHEL and if General Manager is unable or unwilling to act, to the sole arbitration of same other persons appointed by the General Manager, willing to act as such arbitrator.

The cases referred to arbitration shall be other than those for which the decision of the Accepting Officer, or Engineer-in-charge as the case may be, is expressed in the contract to be final and conclusive. There will be no objection if the arbitration, so appointed is an employee of BHEL and that he had to deal with the matters to which the contract relates and that in the course of his duties as such he had expressed views on all or any of the matters in dispute or difference.

The arbitrator to whom the matter is originally referred being transferred or vacating his office or being unable to act for any reason, such General Manager as aforesaid at the time of such transfer, vacation of office or inability to act, shall appoint another person to act as arbitrator in accordance with the terms of the contract. Such person shall be entitled to proceed with the reference from the stage at which it was left by his predecessor.

Subject as aforesaid the provision of the Arbitration Act, 1940 or any statutory modification or re-enactment thereof and the rules made thereunder and for the time being in force shall apply to the arbitration proceeding under this clause.

It is a term of the contract that the party involving arbitration shall specify the dispute or disputes to be referred to arbitration under this clause together with the amount or amount claimed in respect of each dispute.

The arbitrator(s) may from time to time with consent of the parties enlarge the time, for making and publishing the award.

The work under the Contractor shall if reasonably possible continue, during the arbitration proceedings and no payment due or payable to the Contractor shall be withheld on account of such proceedings.

The Arbitrator shall be deemed to have entered on the reference on the date he issues notices to both the parties fixing the date of first hearing.

The Arbitration shall give a separate award in respect of each dispute or difference referred to him.

The venue of arbitration shall be such place as may be fixed by the Arbitrator in his sole discretion.

The award of the Arbitration shall be final, conclusive and binding on all parties to this contract.

In the event of disputes or differences arising between one public sector enterprise and a Govt. Department or between two public sector enterprises the above stipulations shall not apply, the provisions of BPF Office memorandum No. BPF/CL001/76MAN/2(1.10) 75 - BPE (GM - 1) dated 1st January 1976 or its amendments for arbitration shall be applicable.

**61. Jurisdiction of Court**

For the purpose of Court proceeding if any, same shall be in the Court having jurisdiction over Ranipet - 632 406. (Vellore District, Tamilnadu).

**62. Taxes etc. -**

All taxes, duties, levies that are payable to the Government or to any other authorities in respect of the works under the contractor at the time of contract or becomes payable in future shall be exclusively borne by the contractor and the BHEL is not liable for any reimbursement / Payment thereof.

## ANNEXURE - I

### TERMS AND CONDITIONS REGARDING COMPLIANCE WITH VARIOUS LABOUR LAWS BY THE CONTRACTORS FOR BHEL

{Please See Condition - 22}

1. The Contractor shall not employ in connection with the work any person who has not completed 18 years of age.
2. The Contractor shall in respect of labour employed by him either directly or through sub-contractor's comply with or cause to be complied with the following statutory provisions and rules and in regard to all matters provided therein.
  - a) The Contract Labour (Regulation & Abolition) Act 1970 and the related Tamilnadu rules.
  - b) The Minimum wages Act 1948 and the related Tamilnadu Rules.
  - c) The payment of wages Act 1936 and the related Tamilnadu Rules.
  - d) The factories Act 1948 and teh related Tamilnadu Rules.
  - e) The Employees' Provident Fund & Miscellaneous Provisions Act 1952.
  - f) The Employees State Insurance Act 1948.
  - g) The workman's Compensation Act 1923.
  - h) The Industrial Disputes Act 1947 and any other Law or modifications to the above or to the rules made there under from time to time.
  - i) Paymet of Bonus Act 1985.

#### REGISTRATION AND LICENSING

3. Every Contractor shall register his name with the Welfare Section of BHEL before taking up the work awared to him by giving the following information and getting a code Number :-
  - a) The Name of the Contractor.
  - b) Nature of Contract Work.
  - c) Period of Work.
  - d) Number of maximum labour employed by him on anyone day.
  - e) Licence No. & Date (applicable in case of Contractors employing 20 or moreworkers)
  - f) Whether enrolled for PF, ESI, etc., and enrolment No.

This information is called for the purpose of informing the Inspectorate of Factories whenever they call for information regarding Contracts.

4. The Contractor employing 20 or more workmen is required to obtain licence from the authorities (The Deputy Chief Inspector of Factories / Assistant Commissioner of Labour as the case may be). This licence shall be amended and /or renewed wherever there is an increase in the workmen employed by him or in the event of contract being extended or renewed. The Contractor shall inform the licence number to the BHEL Management before taking up the work.
5. The Contractor (licensed or unlicensed) shall promptly furnish every information and document required by BHEL authorities for the purpose of fulfilling their obligations as principal Employer and / or occupier of the factory and shall render all necessary assistance for the same.

#### **WAGES**

6. The Contractor shall pay wages to the workmen employed by him at the rate which shall not be less than the minimum wages applicable under Law from time to time.
7. The Contractor shall fix wage periods in respect of which wages shall be payable. No wage period shall exceed one month.
8. The Contractor shall ensure payment of wages to the Contract labour employed by him within three days from the end of wage period in case the wage period, is one week or a fortnight and in all other cases before 10th day of the following month.
9. All payment of wages shall be made on working days at the work site and during the working time and on dates notified in advance. In case the work is completed before the expiry of the wage period, final payment shall be made within 48 hours of the last working day.
10. Where the employment of any works is terminated by or on behalf of the Contractor, the wages earned by him shall be paid before the expiry of the second working day from the day on which his employment is terminated.
11. Wages due to every worker shall be paid to him direct or to the person authorities by him in this behalf. All wages shall be paid in current coin or currency or in both.
12. The Contractor shall ensure the disbursement of wages in the presence of such authorised representatives of BHEL Management.
13. The above payment shall be verified by the authorised Officers/ representative of BHEL with the following certificates on the payment sheet  
 Certified that the amount shown in Column No..... has been paid to the workmen concerned in my presence on..... at .....
14. A certificate of payment shall be furnished in duplicate by the Contractor to the Engineer-in-charge each month in Form "A" enclosed.

15. A Notice of showing the wage period and the place and time of disbursement of wages shall be displayed at the place of work and a copy to be sent to the welfare department by the Contractor under acknowledgement.
16. Notices showing the rates of wages, weekly rest days, wage period, hours of work, date of payment of wages, and addressed of the Inspectors having jurisdiction the date of unpaid wages shall be displayed in Tamil and English in conspicuous places at the establishment and at worksite the contractor. The contractor shall inform the BHEL Management every month the details of contract labour engaged for each contract in the following form :-
  - a) Serial Number
  - b) Location
  - c) Period of Work
  - d) No. of Contract labour engaged during the work
  - e) No. of days worked
  - f) No. of Mandays worked
  - g) Wages paid to his workers

The above statement shall be furnished to BHEL Management at the end of every month.

#### **REGISTERS AND RECORDS AND COLLECTION OF STATISTICS**

17. The following documents/formats under contract labour (Regulation and Abolition) Act 1970 and Tamil Nadu Rules there under shall be maintained by each Contractor.
  - a) Register of Persons employed by the Contractor.
  - b) Employment Card
  - c) Service Certificate
  - d) Muster Roll, Wage Register, Deduction Register, Wage Slip, Over Time Register, Register of Fines, Register of Advances etc.
18. The Contractor shall display the abstract of the contract labour (Regulation and Abolition) Act and the Rules there under both in English and in Tamil.
19. Half Yearly Return shall be sent by the Contractor in duplicate to the Licensing Officer.
20. The Contractor shall submit the returns required under the Contract Labour (Regulation and Abolition) Act 1970 periodically to BHEL Management.
21. The Contractor shall without fail give upto date information in writing of the attendance of the workers employed by him.

22. The Contractor shall ensure that his workers keep and produce their Employment Card when coming to duty and take them back when leaving duty.
23. All the above registers and records shall be preserved in original for a period of Three years. All the Registers, Records and notice maintained under the Act and rules shall be produced on demand by Inspector or any authority under the Act.

#### **WORKING HOURS AND WORKING CONDITIONS**

24. NO WORKER SHALL BE REQUIRED OR ALLOWED TO WORK ON SUNDAY UNLESS HE HAS OR WILL HAVE A HOLIDAY ON ANYONE OF THE THREE DAYS BEFORE OR AFTER THE SAID DAY.
25. The contractor shall inform BHEL Management in the prescribed form details of the contract workers scheduled to work on Sunday, the day of rest and also indicate the substituted holiday in lieu thereof. This shall be intimated two days in advance before his workmen are booked for work on Sunday.
26. The contract labour working for more than nine hours in any day or for more than 48 hours in any week shall be paid wages at the rate of twice the ordinary rates of wages in accordance with the provisions of section 59 of the factories Act 1948
27. The contractor shall provide all safety devices and personal protective equipment to his workmen at his own cost and shall ensure that his workmen wear/use such devices or equipment provided to them while doing the work and there should not be any relaxation on this.
28. The contractor shall give four paid National Holidays to his workers, viz. 26th January, 1st May, 15th August and 2nd October.
29. The contractor shall ensure that his workmen vacate the premises after the shift is over.
30. No woman worker shall be required or allowed to work in the factory except between the hours of 6.00 a.m and 7.00 p.m
31. The contractor shall comply with the provisions relating to welfare and Health facilities as provided in the contract labour ( Regulation and Abolition ) Act 1970 read with the Tamilnadu contract labour Rules 1975.

#### **NOTICES OF ACCIDENTS**

32. Notwithstanding any thing contrary to this , in the event of accident the contractor shall be required to fill injury report and submit the Engineer-in-charge immediately and ensure the compliance of ESI/Workmen's Compensation Act, Factories Act and Rules made there under. He shall also maintain a register of accident as per Act.
33. The contractor shall get the contract labour engaged by him insured under workmen's Compensation Policy from General Insurance Corporation of India before actually starting the work of contract. The Insurance coverage should

be for the entire period of contract. The contractor shall comply with the provision of the Workmen's Compensation Act 1923 [This should be read in conjunction with the provision of ESI Act]

34. The contractor shall ensure that all his workmen are covered under the Employees State Insurance Act and produce to BHEL such Registration Number/ Enrolment Number before executing the contract work.
35. The contractor shall regularly pay the amount of contribution i.e. employers contribution as well as employees contribution in pursuance of the above scheme as fixed from time to time. The contribution payable presently is 1.75% of wages to be recovered from the workmen and 4.75% of wages to be contributed by the contractor. Contribution recovered from employee and contribution made by the contractor may be rounded to the next higher multiples of five paise.
36. The contractor shall take note of any amendment that may be brought forth in the above contribution rate and accordingly.
37. The contractor shall ensure that his workmen are covered under the EPF & miscellaneous Provision Act 1952 and accordingly produce to the BHEL Management the registration / enrolment number before awarding of contract work. As per the existing provision every worker who has completed three months continuous service or has actually worked for not less than 60 days within a period of three months or less shall be entitled and required to become a member of the fund. The employees' contribution payable at present is 12% of wage which will be recovered by the contractor from the wages of his workmen and the contractor should pay equal contribution. The contractor is also liable to pay any administrative charges in this behalf that may be decided from time to time, it will be the responsibility of the contractor to ensure such contribution payable in respect of workmen employed through sub-contractors also.
38. The contractor shall take note of any amendment in the rate of contribution payable under the scheme from time to time.
39. The contractor shall within seven days of the close of every month submit to BHEL a statement showing the amount of contribution payable/paid for employees engaged by him or through him and shall also furnish to BHEL such information as Principal Employer is required to furnish under the provision of the ESI Act and PF as well as the schemes made thereunder to the authorities concerned.
40. Whenever any sum of money is found to be recoverable from or payable by the contractor under the above Acts the same shall be deducted from any sum that may be due or which at any time thereafter may become due to the contractor under this contract or under any other contract or from his security deposit in case the recoveries are not sufficient to satisfy the claims, the contractor shall pay the balance thereof on demand. In case any recoveries are made this clause shall as may be required to replace the shortage caused by such recoveries in the amount of Security Deposit.

41. The contractor shall abide by all the labour and other laws applicable to contract:labour/worken under this contract and shall at all times keep BHEL Indemnified against all losses, claims, prosecutions under any law.
42. in case of non compliance of any of the provisions of the Acts and in case BHEL Haveing complied with the same BHEL will be entitled to recover the same from the contractor / sub contractor.
43. Non exercise of any of the power of or rights available to BHEL here under or under any law, shall not any way operate as waiver thereof.

ACCEPTING OFFICER

**FORM - IV**

**(See Rule 21(1) of Tamil Nadu Contract Labour Rules)**

**Application for Licence**

01. Name and Address of the Contractor  
(including his Father's Name in case of  
Individuals) :
02. Date of Birth and age (in case of  
Individuals) :
03. Particulars of Establishment where  
Contract Labour is to be employed :
- a) Name and Address of the  
Establishment :
- b) Type of business, trade industry  
manufacture :
- c) Number and date of certificate of  
Registration of occupation, which is  
carried on the Establishment under  
the Act. :
- d) Name and address of the Principal  
Employer :
04. Particulars of contract labour :
- a) Nature of work in which contract  
labour is employed or is to be  
employed in the establishment :
- b) Duration of the proposed contract  
work (give particulars of proposed  
date of commencing and ending) :
- c) Name and address of the agent or  
Manager of contractor at the worksite :
- d) Maximum No. of contract labour  
proposed to be employed in the  
establishment on any date :

- 05. Whether the contractor was convicted of any offence within the preceeding five years, if so give details :
- 06. Whether there was any order against the contractor revoking or suspending licence or forfeiting security deposit in respect of an earlier contract if so the date of such order :
- 07. Whether the contractor has worked in any other establishment within the past five years, if so, give details of the principal employer Establishment and nature of work :
- 08. whether a certificate by the principal Employer in form V is enclosed :
- 09. Amount of licence fee paid No of Treasury challan and Date :
- 10. Particulars of security deposit if any, requested to be adjusted, including Treasury Receipt number :
- 11. The amount of security deposit or balance if any after adjustment of amount to be refunded under rule 31 deposited with treasury Receipt Number and date :

**DECLARATION**

I hereby declare that the details above are correct to the best of my knowledge and belief.

**PLACE :**  
**DATED :**

**SIGNATURE OF THE APPLICANT**  
**[CONTRACTOR]**

**NOTE :** The application should be accompanied by a treasury Receipt for the appropriate amount and a certificate in Form V From the principal employer.

(To be filled in the office of the Licensing officer)

Date of receipt of the application with challan for fees / security Deposit.

**SIGNATURE OF THE LICENSING OFFICER**

**CONTRACTOR**

**FORM - XIII**

**(See Rule 75 of Tamil Nadu Contract Labour Rules 1975)**

**Register of workman employed by contractor**

Name and Address of the Contractor :

Name and location of work :

Name and address of establishment in /under  
which contract is carried on :

Name and address of Principal Employer :

01. Serial Number :

02. Name and surname of workman :

03. Age and sex :

04. Father's / Husband's Name :

05. Nature of Employment /Designation :

06. Permanent Home address of workman  
( village Taluk and District ) :

07. Local Addresss :

08. Date of commencement of Employment :

09. Signature or Thump Impression of workman :

10. Date of termination of Employment :

**CONTRACTOR**

**FORM - XIV**

**(See Rule 76 of Tamil Nadu Contract Labour Rules)**

**EMPLOYMENT CARD**

Name and Address of contractor : Name and address of  
Establishment in/under which  
contract is  
carried on \_\_\_\_\_  
\_\_\_\_\_

Nature of work and location of work : Name and address of  
Principal Employer  
\_\_\_\_\_

01. Name of the workmen :

02. Sl. No. of register of workmen employed :

03. Name of Employment/Designation :

04. Wage rate (with particulars of unit in case of  
Piece work) :

05. Wage period :

06. Tenure of Employment :

07. Remarks :

**SIGNATURE OF CONTRACTOR**

**CONTRACTOR**

FORM - XV

{See Rule 77 of Tamil Nadu Contract Labour Rules}

**SERVICE CERTIFICATE**

Name and Address of the contractor : Name and address of  
Establishment in/under which  
contract is  
carried on \_\_\_\_\_  
\_\_\_\_\_

Name and location of the work :

Name and address of the workman : Name and address of Principal  
Employer  
\_\_\_\_\_

Age or Date of Birth :

Identification marks :

Father's / Husband's Name :

Sl.No	Total period for which employed		Nature of work done		Rate of wage (with particulars units in case of piece of work	Remarks
	From	To	(4)	(5)		
(1)	(2)	(3)	(4)	(5)	(6)	(7)

**SIGNATURE**

CONTRACTOR

**FORM - XVI**

(See Rule 78 [1] [a] [i] of Tamil Nadu Contract Labour Rules)

**MUSTER ROLL**

Name and Address of contractor : Name and address of Establishment in/under which contract is carried on \_\_\_\_\_

Nature of location of the work : Name and address of Principal Employer \_\_\_\_\_

For the Month of \_\_\_\_\_

Sl. No	Name of workmen	Father's/Husbands Name	Sex	Dates					Remarks	
				1	2	3	4	5		
(01)	(02)	(03)	(04)	(05)	(06)					

**SIGNATURE OF CONTRACTOR**

**CONTRACTOR**

**FORM - XVII**

**(See Rule 78(1) (a) (i) of Tamil Nadu Contract Labour Rules)**

**Register of wages**

Name and Address of the Contractor :

Nature and location of work :

Name and address of establishment in/under  
which contractor is carried on :

Name and address of Principal Employer :

Wage Period : MONTHLY

01. Serial Number :

02. Name of workman :

03. Sl. No. in Register of workman :

04. Designation / Nature of work done :

05. No. of days worked :

06. Units work done :

07. Daily rate of wages / Piece rate :

08. Basic wages :

09. Dearness allowance :

10. Overtime :

11. Other cash Payment  
(Nature of payment to be indicated ) :

12. Total :

13. Deductions, If any [indicate nature ] :

14. Net amount paid :

15. Signature / Thumb impresion of workman :

16. Initials of contractor or his representative :

**CONTRACTOR**

**FORM - XIX**

(See Rule 78(1) (b) of Tamil Nadu Contract Labour Rules)

**Wage Slip**

Name and Address of the Contractor : Name and Father's /  
Husband Name of the  
workman \_\_\_\_\_

Name and location of work : For the week / Fortnight /  
Month ending .....

01. No. of days worked :

02. No. of units worked in  
case of piece rate workers :

03. Rate of daily wages /piece rate :

04. Amount of over time wages :

05. Gross wages Payable :

06. Deductions, if any :

07. Net amount of wages paid :

**INITIALS OF THE CONTRACTOR OR  
HIS REPRESENTATIVE**

**CONTRACTOR**

FORM - XX

(See Rule 78(1) (a) (ii) of Tamil Nadu Contract Labour Rules)

Register of deductions for damage or loss

Name and Address of the Contractor :

Nature and location of work :

Name and address of establishment in/under  
which contractor is carried on :

Name and address of Principal Employer :

01. Serial Number :

02. Name of workman :

03. Father's / Husband's Name :

04. Designation / Nature of employment :

05. Particular of damage or loss :

06. Date of damage or loss :

07. Whether workman showed cause  
against deduction :

08. Name of person in which presence  
employee's explanation was heard :

09. Amount of deduction imposed :

10. No. of instalments imposed : Date of Recovery

11. First Instalments :

12. Final Instalments :

13. Remarks :

CONTRACTOR

**FORM - XXI.**

**(See Rule 78(1) (a) (ii) of Tamil Nadu Contract Labour Rules)**

**Register of Fines**

Name and Address of the Contractor :

Nature and location of work :

Name and address of establishment in/under  
which contractor is carried on :

Name and address of Principal Employer :

01. Serial Number :

02. Name of workman :

03. Father's / Husband's Name :

04. Designation / Nature of employment :

05. Act / Omission for which fine imposed :

06. Date of offence :

07. Whether workman showed cause against  
fine :

08. Name of the person in whose presence  
employee's explanation was heard :

09. Wage period & Wage payable :

10. Amount of fine imposed :

11. Date on which fine realised :

12. Remarks :

**FORM - XXII**

**(See Rule 78 (1) (a) (ii) of Tamil Nadu Contract Labour Rules)**

**Register of Advance**

- Name and Address of the Contractor :
- Nature and location of work :
- Name and address of establishment in/under which contractor is carried on :
- Name and address of Principal Employer :
01. Serial Number :
02. Name of workman :
03. Father's / Husband's Name :
04. Designation / Nature of employment :
05. Wage period and wages payable :
06. Date and amount of advance given :
07. Purposes (s) for which advance made :
08. No. of instalments by which advance to be repaid :
09. Date and amount of each instalment repaid :
10. Date on which instalment was repaid :
11. Remarks :

**CONTRACTOR**

**FORM - XXIII**

**(See Rule 78(1) (a) (iii) of Tamil Nadu Contract Labour Rules)**

**Register of Overtime**

Name and Address of the Contractor :

Nature and location of work :

Name and address of establishment in/under  
which contractor is carried on :

Name and address of Principal Employer :

01. Serial Number :

02. Name of workman :

03. Father's / Husband's Name :

04. Sex :

05. Designation / Nature of employment :

06. Dates on which overtime worked :

07. Total overtime worked or production  
in case of piece -rated :

08. Normal rate of wages :

09. Overtime rate of wages :

10. Overtime earning :

11. Date on which Overtime wages paid :

12. Remarks :

**CONTRACTOR**

# PAYMENT CERTIFICATE

## FORM "A"

Certified that :

1. I as contractor of .....  
have made payment to all contract Labourers in full in respect of contract  
No. .... as per terms of my contract  
and in no case less than the rates applicable upto the period ending.
2. The above payment have been made by me in the presence of the au-  
thorised representative of .....  
of ..... for .....  
Employees amounting to Rs .....
3. The necessary payment registers attendance register / Form 12 . Leave  
register / book under Laboure and industrial Law and other relevant records  
have been maintained by me and available with me for production as and  
when required .
4. No payment is due / outstanding to any contract Labourers engaged by  
me in respect of the aforesaid contract upto the period ending  
.....

### CONTRACTOR

NAME :  
DATE :

### SUPERVISOR

NAME :  
DESIGN :  
DATE :

COUNTERSIGNED  
OFFICER INCHARGE

NAME :  
DESIGN :  
DEPT. :

CONTRACTOR

**ANNEXUR II**  
**SAFETY RULES**  
**(See Condition 2)**

**A BHEL SAFETY CODE**

**A**

1. Suitable scaffolds shall be provided for workmen for all work that cannot safely be done from the ground, or from solid construction except such short period of work as can be done safely from ladder. When a ladder is used an extra mazdoor shall be engaged for holding the ladder and if the ladder is used for carrying materials as well suitable footholds and handholds shall be provided on the ladder and the ladder shall be give an inclination not steeper than  $\frac{1}{4}$  to 1 ( $\frac{1}{2}$  horizontal and 1 vertical)
2. Scaffolding or staging more than 3.25 metres above the ground or floor, swing or suspended from an overhead support or erected with stationary support, shall have a guard rail properly attached, bolted braced and otherwise secured atleast 1 metre high above the floor or platform of such scaffolding or staging and extending along the entire length of the outside and ends thereof with only such opening as may be necessary for the delivery of materials. Such scaffolding or staging shall be so fastened as to prevent it from swaying from the building or structure.
3. Working platform, gangways and stairways shall be so constructed that they do not sag unduly or unequally, and if height of a platform or gangway or stairway is more than 3.25 metres above ground level or floor level it shall be closely boarded, have adequate width and be suitably fenced, as described in 2 above.
4. Every opening in floor of a building or in a working platform shall be provided with suitable means to prevent fall of persons or materials by providing suitable fencing or railing with a minimum height of 1 metre.
5. Safe means of access shall be provided to all working platform and other working places. Every ladder shall be securely fixed, no portable single ladder shall be over 9 metres in length. Width between side rails in a rung ladder shall in no case be less than 30 cm for ladders upto and including 3 metres in length, For longer ladder this width shall be increased by atleast 6mm for each additional 30cm of length. Uniform step spacing shall not exceed 30cm.

Adequate precautions shall be taken to prevent danger from electrical equipment. No materials on any of the sites shall be so stacked or placed as to cause danger or inconvenience to any person or the public. The contractor shall provide all necessary fencing and light to protect public from the accident and shall be bound to bear expenses of defence of every suit-action or other proceeding at law that may be brought by any person for injury sustained owing to neglect of the above precautions, and pay any damages and cost which may be awarded in any such suit, action or proceeding to any such person or which may with the consent of the contractor be paid to compromise any claim by such person.

## 6. Excavation and Trenching

All trenches 1.5 metres or more in depth, shall at all time be supplied with atleast one ladder for each 30m length or fraction there of ladder shall be extended from bottom of trench to atleast 1 metre above surface of the ground . Sides of the trench 1.5 metres or more in depth shall be stepped back to give suitable slope or securely held by timber bracing,so as to avoid the danger of sides collapsing . Excavated materials shall not be placed within 1.5 metres of the edge of trench or half the depth of trench, whichever is more. Cutting shall be from top to bottom under no circumstances shall under mining or under - cutting be done.

## 7. Demolition :

Before any demolition work is commenced and also during the progress of work.

- a) All roads and open areas adjacent to the work site shall be closed or suitably protected .
  - b) No electric cable or apparatus which is liable to be a source of danger over a cable or apparatus used by the operator shall remain electrically charged.
  - c) All practical steps shall be taken to prevent danger to person employed from the risk of fire or explosion ,or flooding no floor , or roof or other part of building shall be so overloaded with debris or materials as to render it unsafe.
8. All necessary personal safety equipment as considered adequate by the Engineer-in-charge shall be available for use of person employed on the site and maintained in a condition suitable for immediate use and the contractor shall take adequate steps to ensure proper use of equipment by those concerned.
- a) Workers employed on mixing asphaltic materials cement and lime mortars concrete shall be provided with protective footwear and protective gloves.
  - b) Those engaged in handling any material which is injurious to the eye shall be provided with protective goggles.
  - c) Those engaged in welding work shall be provided with welder's protective eye shells
  - d) Stone breaker shall be protective goggles and protective clothing and seated at sufficiently safe intervals.
  - e) When workers are employed in sewers and manholes which are in use , the contractor shall ensure that manhole covers are opened and manholes are ventiled atleast for an hour before the workers are allowed to get into them manholes so opened shall be cordoned off with suitable railing and provided with warning signals or boards to prevent accident to public.
    - i) No paint containing lead or lead products shall be except in the form of paste or ready-made paint.
    - ii) Suitable face masks shall be supplied for use by workers when paint applied in the form of spray or surface having lead paint is dry rubbed and scrapped .

f) The contractor shall not employ men below the age of 18 and women on the work of painting with products containing lead in any form. Whenever men above the age of 18 are employed on the work of lead painting the following precaution shall be taken :

A f i) No paint containing lead or lead products shall be used except in the form of paste or ready-made paint.

ii) Suitable face masks shall be supplied for use by workers when paint is applied in the form of spray or surface having lead paint is dry rubbed and scrapped

iii) Overalls shall be supplied by the contractor to workmen and adequate facilities shall be provided to enable working painters to wash during or cessation of work.

9. When work is done near any place where is risk of drowning ,all necessary equipment shall be provided and kept ready for use and all necessary steps taken for prompt rescue of any person in danger and adequate provision made for prompt first aid treatment of all injuries likely to be sustained during the during the course of the work.

10. Use of hoisting machine and tackles including their attachments,anchorage and support shall conform to the following

a)

i) These shall be of good mechanical construction, sound materials and adequate strength and free from defects and shall be kept in good working order.

ii) Every rope used in hoisting or lowering materials or as a means of suspension shall be of durable quality and adequate strength and free from defects.

b) Every crane driver or hoisting appliance operator shall be properly qualified and no person under the age of 21 yrs shall be incharged of any hoisting machine including any scaffolding winch or give signals to operator.

c) In case of every hoisting machine and or every chain ,ring , hook, shackle swivel and pull block used in hoisting or lowering as means of suspension safe working load shall be ascertained by adequate means. Every hoisting machine and all gear referred to above shall have the safe working load plainly marked there on. In case of a hoisting machine having a variable safe working load,each safe working load at the condition under which it is applicable shall be clearly indicated. No part of any machine or gear referred to above in this paragraph shall be loaded be yond the safe working load except for the purpose of testing.

d) In case of department machine ,safe working load shall be notified by the Engineer-in-charge. As regards contractor's machine the contractor shall notify safe working load of each machine to the Engineer-in-charge when ever he brings it to site of work and get it verified by the Engineer-in-charge.

11. Motors , gearing , transmission electric wiring and other dangerous parts of hoisting appliances shall be provided with efficient safeguards. Hoisting appliances shall be provided with such means as will reduce to the minimum risk of accident descent of load . Adequate precaution shall be taken to reduce to the minimum risk of any part of a suspended load becoming accidentally displaced. When workers are employed on electrical installations which are already energised insulating mats, working apparel such as gloves, sleeves and boots as may be necessary shall be provided. Workers shall not wear any rings watches , carry keys or other materials which are good conductors of electricity.
12. All scaffolds , ladders and other safety devices mentioned or described here in shall be maintained in a safe condition and no scaffold , ladder or equipment shall be altered or removed while it is use. Adequate washing facilities shall be provided at or near the places of work.
13. These safety provision shall be brought to the notice of all concerned by display on a notice board at a prominent place at the workspot persons responsible for ensuring compliance with the safety code shall be named thereon by the contractor.
14. To ensure effective enforcement of the rules and regulations relating to safety precaution , arrangement made by the contractor shall be open to inspection by the Engineer-in-charge or his representation and the inspecting officers as defined in the contractor's Labour Regulations.
15. Notwithstanding to the above conditions 1 to 14, the contractor is not exempted from the operation of any other Act or Rule in force.

## **B. GENERAL SAFETY PRECAUTIONS TO BE FOLLOWED AT WORK SITES DURING EXECUTION**

The following safety measures should be strictly adhered to during execution of works at sites.

1. Providing the working platform with toe-board and handrail for continuous working at heights.
2. Providing safety belt and lifeline at all times for men working at heights.
3. Providing dust or fume respirator in places where dust and fume concentration exists
4. Providing goggles and welding screens.
5. Providing acid and alkali proof rubber gloves for handling acids, alkali and chemicals, which are corrosive.
6. Providing rubber gloves for working on electrical works.
7. Ensuring proper lashing of the components while being transported in vehicles.
8. The vehicles must have side supports or have body to support the materials conveyed.
9. The materials should not be allowed to extend or overflow the sides of vehicles.
10. Materials should not be allowed to overhang from the rear edge of the body of the vehicle.
11. Driver of the vehicle must possess license.
12. Vehicle must not be overloaded prescribed limits.
13. Red flags and lights for parts projecting from the body of the vehicle must be provided.
14. The speed restrictions within the factory must be strictly adhered to.
15. The gas cylinders must always be handled on trolleys or kept tied down not in use. They should never be rolled as Roller for conveying.
16. Cylinders should not be used without regulators.
17. All excavations may be barricaded and red belts/ lamps must be provided .
18. All electrical connections must be properly earthed.
19. No work should be taken up for execution inside shop floor, without obtaining necessary work permit.
20. Providing helmet for high level work.
21. The contractor should maintain a register regarding the driver license particulars.
22. All Personnel Protective Equipments (PPE) conform to standard specification as per the details given in the code of conduct.
  - (i) Safety helmets confirming to IS-2925: 1984
  - (ii) Safety Belts confirming to IS-3521: 1983
  - (iii) Safety Shoes confirming to IS-1989: 1978
  - (iv) Eye and face protection devices confirming to IS – 8520:1977 & IS – 8940:1978
  - (v) Hand and body protective devices confirming to: IS – 2573: 1975  
IS – 6994: 1973  
IS – 8807: 1978  
IS – 8519: 1977

Contractor including the subcontractors, agents and labours engaged on work are required to scrupulously adhere to the safety regulations, safety precautions and measures. Any violation thereof will invite punitive action being taken against them. Also contractors with frequent violations of safety regulations will not be entrusted with further work in this organization.

### **General:**

All tools, tackles, lifting appliances, material handling equipment, scaffolds, cradles, safety nets, ladders, equipment etc., used by the contractor shall be of safe design and construction. These shall be tested and certificate of fitness obtained, before putting them to use and from time to time as instructed by authorized BHEL official who shall have the right to ban the use of any item.

### **C. SAFETY PRECAUTION TO BE OBSERVED WHILE TRANSPORTING MATERIALS**

#### **I. Vehicle**

1. Vehicle carrying materials should have proper registration documents and must be produced on demand by our Security staff.
2. The light on right side i.e. over the driver's cabin shall be in working condition
3. Both the head light as well as park lamps must be in working condition.

#### **II. Movement of Vehicle**

1. The vehicle should not travel at more than 20KMPH in our premises.
2. The driver of the vehicle must possess heavy duty licence and produce on demand by the Security Staff.
3. Vehicles carrying inflammable liquids in the tanks containers should have grounding chain or the tank container should be coated with insulating materials to avoid static electricity.
4. In road junction , speed breaker and Railway crossing the speed should be lowered and vehicles should proceed cautiously.
5. The driving should be ' keep to the left ' at all places.
6. The vehicles should not parked on the road which could obstruct the vehicular traffic.
7. No person other than driver should be allowed to sit or stand on the prime mover or trailer.
8. The vehicle should pass only through the approved routes. Short cuts should be forbidden.
9. There must be a safe distance behind another moving truck.
10. The driver should avoid making quick starts, jerk stop or quick turns at excessive speed .

### III Shipping

1. Strong side supports should be provided on both sides of the trailer. The side supports should be fixed in such a way that it cannot be removed even temporarily.
2. Adequate packing must be given for easy slinging operations. The packing materials should be good enough to withstand the load.
3. The stacking of loads on the truck should be evenly placed. The load should not be heaped together or dumped over the chassis.
4. The load on the truck should not be beyond its standard capacity. The carrying capacity must be clearly marked on the trailers also.
5. The loaded materials should be fastened tightly with "WIRE ROPE". Manila rope or coir rope should not at all be used. There must be side packing such as gunny or rubber tyre between the sharp edges of the job and wire rope in order to avoid cut in the wire rope.
6. There must be minimum two fastening and it should be more in case of lengthier loads.
7. The wire rope should be in sound condition i.e there should not be links, knots or bristles etc.
8. The wire rope ends should be clamped with 'U' clamps.
9. The loose pieces should be bundled before loading on the truck.
10. There must be red flags or red lamps for the lengthly loads which extend beyond chassis.
11. The materials should not be stacked too high to avoid hitting against live electric lines.
12. The load should not be overhanging more than 0.9 metres from the end of body.
13. While transporting the scraps, there must be wire net cover to prevent falling of scrap.

### IV General

1. The vehicles should not be moved directly inside the production building in case the materials are to be unloaded there. But the vehicles should be parked outside the building and the driver should ascertain the passage as well as the unloading points, with the help of the shop officials. This will avoid the congestion or blocking of traffic in the gangway.

## **GENERAL AND SPECIAL SPECIFICATIONS**

### **1. Site Clearance**

All the area upon which the construction is to be carried out and areas which are required by the Contractor for his construction facilities are to be cleared off all rubbish and objectionable matter at Contractor's own cost. Trees, if any, shall not be uprooted or cut without the prior approval of the Engineer-in-charge. All spoils, unserviceable materials and rubbish shall be burnt or removed from site. Usable materials, saleable timber, fire-wood etc., shall be stocked properly at work site in the manner as directed by the Engineer-in-charge. The cost of clearing the areas shall be deemed to have been included by the tenderer in his general rate.

### **2. Earthwork for Foundations**

Earthwork excavation for foundations and filling in foundations shall conform to TNBP 23 and 24. The area to be excavated or filled in with excavated materials shall be clearly demarcated in the field by the Contractor. Excavation shall be done to lines and levels defined. Excavation shall be carried out to such widths, lengths, depths, profiles and grades as shown in the drawing or as may be specified by the Engineer – in – charge. Rough Excavation may be carried out up to a depth 15 cm less than the final level but the balance shall be excavated to precise level with special care. All soft pockets of soil met with even below the final level shall be removed and the excavation filled up as directed by Engineer-in-charge. The methods of excavation shall in every case be subject to the approval of the Engineer-in-charge and the contractor shall ensure the safety and stability of the excavations, being executed by him as well adjacent buildings, structures, services and other works in the vicinity of the site of work. Wherever necessary Engineer-in-charge may direct that the sides of the excavation should be timbered and shored at the contractor's own cost, adopting a proper method approved by the Engineer-in-charge. Notwithstanding the above, should any slip occur, the contractor shall remove all the slipped materials from the excavated pit, at his own cost. He shall also make good at his own all damages caused to the work as well as adjacent buildings, structures etc., as a result of the slip, referred to.

All excavation work shall be subject to inspection and approved by the Engineer-in-charge before any further works in the excavated areas allowed to commence. Should any excavation be carried out beyond the specified depth, the contractor should fill it up at his own cost with the same type and class of material as it is proposed to be laid over the excavated portion. No payment will however be made to the contractor on his account.

The contractor shall ensure that the excavations and the structures under construction are kept free from water logging at all stages of construction. He shall take all necessary precautions and implement measure so that ground water and water from other sources such as under ground streams, aquifers, springs, surface flows etc., are excluded effectively so as to ensure that the works are carried out in a reasonable dry conditions in accordance with the construction schedule. The contractor's quoted rate for excavation shall include charges for such dewatering also.

Back filling around the foundations, trenches, plinth and under the floor shall be done in accordance with TNBP 24 and 25. The finished level of the plinth filling shall be trimmed to the slope required to be given to the finished floor. No separate payment will be made for back filling in foundation with excavated earth as the rate quoted for excavation shall include charges for back filling, watering and consolidation of excavated earth in layers complete as per specifications unless otherwise stipulated in the tender schedule.

**CONTRACTOR**

**ACCEPTING OFFICER**

### **Removal of Hard rock by Blasting**

This shall include all rock occurring in large masses which cannot be removed except by blasting. Blasting shall be done in conformity with TNBP 19 & 23 and as instructed by the Engineer-in-charge. When rock blasting has to be done adjacent to structures, the following precautions shall be observed.

- (1) All blasting should be completely muffled to prevent damage by flying pieces.
- (2) Blasting within 3 meters of the structures shall be avoided
- (3) No blasting should be done within 1.5 meters of concrete / masonry structures.
- (4) An isolated boulder extending under the existing structure but projecting within the area of blasting should be blasted.
- (5) The contractor shall be responsible for all damages caused by blasting and shall replace or repair the damaged structures at his own cost.

### **3. Plain and Reinforced Cement Concrete Works :**

All design and construction shall be performed in accordance with the Indian standard code of Practice for plain and reinforced concrete – IS 456 and TNBP 30. Any Special requirements noted on the drawings or bill of quantities shall govern over the provisions of this specifications. Controlled concrete shall be used wherever specified in the schedule of items complying with all requirements of IS : 456 and as per special specifications appended herewith.

The coarse aggregate to be used shall be of hard broken granite stone jelly of various sizes as specified under respective items in the Bill of Quantities, conforming to IS 383 latest edition. The Engineer-in-charge may require the contractor to carryout moisture content tests in both fine and coarse aggregates. For determination of moisture content IS – 2386 shall be referred to. The amount of water to be added shall be then adjusted to compensate for any observed variation in the moisture contents. Proper control of mixing water is deemed of paramount importance. Mixtures with automatic water measuring drums shall be used or else. Water should be measured by volume in calibrated buckets. All measuring equipments shall be maintained in a clean serviceable condition and the accuracy periodically checked and got certified by the Engineer-in-charge. The contractor shall carryout slump tests apart from taking test cubes at regular intervals. All such methods of sampling and analysis of concrete shall be in accordance with IS – 1199.

Mixing of concrete shall be strictly carried out in an approved type mechanical mixer. The mixing equipment shall be capable of combining the aggregates, cement and water within the specified time ( not less than 2 Minutes) into a thoroughly mixed and uniform mass and of discharging the mixture without segregation. Mixing shall be continued until there is a uniform colour and consistency. Concrete shall be handled from the place of mixing to the place of final deposit as rapidly as practicable by methods which will prevent segregation or loss of any of the ingredients. Before depositing the concrete, all debris and dirt shall be removed from the space to be occupied by concrete. Concreting shall not be done unless the form work conform to the shapes, lines and dimension as shown in the drawings.

**CONTRACTOR**

**ACCEPTING OFFICER**

Unless otherwise approved, concrete shall be placed on single operation to the full thickness of slabs and beams and similar members and not exceeding 1 metre deep in walls, columns and similar members. Concrete shall be placed continuously until completion of the part of the work between construction joints or as directed by the Engineer-in-charge. The concrete after being laid shall be compacted by means of vibrators of approved type under proper supervision as directed by the Engineer-in-charge. Care should be taken to avoid segregation and formation of air bubbles. The whole process starting from the mixing of concrete to the placing and compaction shall not take more than 20 minute and the process shall be completed before the initial setting takes place. Curing shall be accomplished in accordance with IS-456 by keeping the concrete covered with a layer of sacking, canvas or similar absorbent materials and kept constantly wet for the period as directed by the Engineer-in-charge.

### **Reinforcement**

All reinforcement shall be clean and free from pitting, loose mill-scales, dust, loose rust and coats of paint, oil or other coatings which may destroy or reduce bond. General construction details and workmanship relative to reinforcement including bar bends, lap splices and installation shall be in accordance with the IS-2502 as well as IS-456. All bars be bent as per the bar bending schedules indicated in the drawings or supplied separately relevant to particular drawing. The contractor shall in all cases verify himself the correctness of schedules, giving the number, length and the bending details of the bars. The numbers, sizes, shape and position of all the reinforcement shall, unless otherwise, directed or authorized by the Engineer-in-charge be strictly in accordance with the drawing. The reinforcement shall be adequately held in position by 18 / 20 SWG soft black annealed binding wire. The contractor must obtain the approval of Engineer-in-charge for the reinforcement placed, before any concrete is placed in the form. All reinforcing bars shall be so tied as to form a rigid cage to prevent displacement before or during concreting. Rate quoted for reinforcement should include cost of transporting M.S. Rods / CTD bars from BHEL Store to site of work, cleaning, cutting, bending, placing, binding with contractor's own binding wire and providing necessary cover blocks of concrete but excluding cost of steel which shall be supplied free of cost at BHEL Stores.

### **Form Work**

Form work shall conform to the shape, lines and dimensions of concrete and RCC structures as shown in the drawings and shall be well within the permissible tolerance. Form work for concrete shall be of plywood, steel, good seasoned timber or other approved materials, properly designed easy for removal and cleaning. They shall be of sufficient strength and rigidity to maintain their position and shape under loads incidental to placing concrete. The number of props, their sizes and dispositions shall be such as to able safely carry the full dead load area constructional loads. The arrangement and alignment of formwork shall be got approved by the Engineer-in-charge prior to concreting. However this shall not relieve the contractor from his responsibility for proper work and safety. Form work shall be sufficiently tight to prevent loss of cement slurry from the concrete. All joints and holes in the form work shall be caulked with putty jute cloth or other approved materials to the satisfaction of the Engineer-in-charge. The stripping time for the shuttering and the formwork shall in general conform to the provisions in the relevant clauses of IS 456. Unless otherwise specified rates for reinforced cement concrete shall include cost of centering, shuttering charges also.

**CONTRACTOR**

**ACCEPTING OFFICER**

## **Expansion and Other Joints**

Expansion Joints in concrete structures shall be provided at specified places as indicated in the drawings. The material shall be as specified by the Engineer-in-charge, expansion joints, with or without metal strip shall be as shown on drawings the filler shall be "EXPANDEX JOINT FILLER" premoulded non – extrudent type fibrous joint filler impregnated with bitumen conforming to IS : 1838 – 1961. The filler shall be durable, water proof, compressible and shall have a high degree recovery after compression is released, ensuring thereby that no free space develops in the expansion joints. The top 25 mm, or as specified in the drawings, shall be sealed with "SHALITEX SEALING COMPOUND" or equivalent after application of approved primer.

## **4. Stone Masonry**

General : Stone masonry shall conform to TNBP 35. Stone shall be obtained from the approved quarry and shall be free from decay and weathering.

All stones shall be thoroughly wetted before use. The mortar used for jointing shall be as specified under the respective items of the ' Bill of Quantities'.

The walls shall be carried up truly plumb. Every stone shall be carefully fitted to the adjacent stones so as to form neat and closed joints.

To give sufficient lateral bond, vertical joints shall be avoided. Prescribed number of headers as required shall be provided to give sufficient transverse bond. At junctions of wall the stones each alternate course shall be so carried into each of the respective walls as to unite the work thoroughly. Where breaks are unavoidable in carrying up the work continuously in horizontal course sufficiently long steps shall be left to joint the old and new work building of two thin faces and filling up the middle with small stuff or dry packing shall be strictly avoided. When plastering or raised pointing is not required to be done joints shall be struck flush and finished simultaneously.

### **Coursed Rubble Masonry**

Coursed rubble masonry shall conform to TNBP 35-H, I and J. Faces shall be accurately squared and all face joints shall be dressed at right angles. This bushing on the facing stones shall not project more than 38mm.

Face stones shall be laid alternate headers and stretchers. Depth of each course shall not be less than 150 mm. No course shall be greater than any course below. The height shall not exceed the breadth of stones of face. No stone shall tail into the wall less than its height. No pinning shall be allowed on the face. The stones shall be solidly bedded set full in mortar with joints not exceeding 12 mm in thickness.

### **Random rubble masonry**

Random rubble masonry work shall conform to TNBP 35-L and J. Stones shall be hammer dressed at faces and joints to enable them to come into close proximity with each other. The face stone shall be laid headers and stretchers alternately, so as to break joint by at least 75mm. Thickness of joint shall not exceed 12mm. No pinning shall be used on the face and face stone shall extend well back into the headers. Stones less than 130 mm. in height shall not be used on the face.

Bond stones running through the wall shall be provided at 1.8M intervals in walls up to 0.60 M. thickness and if the wall is more than 0.60 M. thick a line of headers shall be laid from face to back each header overlapping the other by at least 150 mm.

**CONTRACTOR**

**ACCEPTING OFFICER**

## **5. Brick Masonry :**

First class Bricks : Brick shall be sound, hard, tough, rectangular in shape and size, well burnt of uniform deep red or copper colour and conform to IS – 1077.

Brick shall be free from cracks, chips, flaws, stone or humps of any kind. Bricks shall be homogeneous in texture and emit a clear ringing sound on being struck and shall have a minimum compressive strength of 70KG / sq.cm. and shall not absorb water more than 20% of its weight, when soaked cold water for 24 Hrs. All bricks shall be table moulded.

Second Class Bricks : These shall be ground moulded but should otherwise conform to the specifications of first class bricks except for some surface cracks are allowable. These shall have minimum compressive strength of 70 Kg./sq.cm.

Samples of each type of brick, shall be got approved by the Engineer-in-charge before being used. All subsequent deliveries shall be up to the standards of the approved samples.

Brick work shall conform to TNBP31 and IS –2212.

Brick works shall be classified as first or second class according to the classification of bricks used and the method of laying. The thickness of joints shall not exceed 6 mm. In first class brick work and 10 mm in second class brick work.

Unless otherwise specified in the Bill of quantities standard metric bricks of size 19cm X 9 cm X 6 cm. shall be used.

Bricks shall be well soaked before use on works for at least 6 hrs. The soaked bricks shall be kept on wooden planks or platform. Brick required for masonry with clay or lime mortars shall not be soaked.

Brick work shall be laid with specified mortar to be prepared in accordance with IS –2250. Brick works shall be laid in English Bond unless otherwise specified. Half or cut bricks shall not be used except when needed to complete the bond. Each course shall be taken up truly plumb, if battered, the batter is to be truly maintained. The level of brick work shall be checked up at every one metre interval. Bricks shall be laid with frogs upward, while laying bricks shall be thoroughly bedded and flushed in mortar and taped into position with a wooden mallet and the superfluous mortar removed. Walls of all structures shall be carried up regularly in all cases, leaving no part, one metre lower than the other. Where the masonry of one part has to be delayed, the work shall be raked back according to bond ( and not toothed ) an angle not exceeding 45 Deg. But the raking back should not start within 60cm. of a corner vertical joints in alternate courses shall come directly over one another. The brick work shall not be raised more than 14 courses per day. All iron fixtures, pipes, conduits, drains, sleeves, bolts, holdfasts of doors and windows etc. which are required to be built in walls shall be embedded in cement mortar or cement concrete as specified, in their correct position as the work proceeds.

### **Joints**

Joints shall be restricted to 6 mm in first class brick work and 10mm in second class brick work. All bed joints shall be normal to the pressure upon them, radial in arches and at right angles to the face in battered retaining walls. Care shall be taken that all joints are fully mortared ( proportion as specified in the schedule items ) well flushed up and in case where no pointing to be done, neatly struck at the work proceeds. The joints in faces which are to be plastered or pointed shall be squarely raked out to a depth of 12 mm while the mortar is still green. The raked joints shall be well brushed to remove loose particles. After the work the faces of work shall be cleared well by brush so as to remove any splashed mortar during the course of raising the brick work.

**CONTRACTOR**

**ACCEPTING OFFICER**

## **Curing**

Green work shall be protected from rain by suitable covering. Masonry work shall be kept thoroughly well watered on all faces for atleast 10 days after completion. In case of fat lime mortar curing shall commence two days after laying of masonry and shall continue for seven days.

## **6. Scaffolding**

Scaffolding will generally be single but may be double if warranted for the particular work as approved by the Engineer-in-charge. The contractor shall take all measure to ensure safety of work and the working people.

Payment for brickwork shall be made on cubic metre basis on the volume of actual work done. Half brick wall and brick on edge wall shall be paid on square metre basis. The rate of brick work shall include scaffolding and all items mentioned above and no extra payment will be made for cutting bricks if required either for openings or for rounding or insertions or for recesses at the time of brick wall construction.

## **7. Damp Proof Course**

Damp proof course shall either be with cement concrete or with cement mortar of specified thickness as mentioned in the relevant item of schedule. Damp proof course shall not be carried across doorways. It shall be laid for all walls except verandah retaining wall or for particular wall only directed by the Engineer-in-charge. It shall be laid flush with floor level or as instructed by the Engineer-in-charge.

Damp proof course with cement concrete shall be of 25 or 38 mm thick in cement concrete M-150/M-200 as specified using 12mm. and down size aggregate well rammed and smoothed with trowel. It will be kept wet for 40 hours and after it has dried, two coats of hot bitumen shall be applied over it and allowed it to dry after which sand shall be sprinkled over it.

Damp proof course with cement mortar shall be 12 or 20 mm thick in cement mortar 1:3 well mixed with crude oil at 5% by weight of cement used.

## **8. Cement Plastering :**

Cement plastering shall be in accordance with IS – 1661 and TNBP –56 & 57, Cement mortar shall conform to IS – 269. The mortar of specified mix and thickness shall be used.

The surface to be plastered shall be thoroughly cleaned so that it is free from dust, oil, salts etc., The joints of masonry shall be raked out to a depth of atleast 12 mm. On cement concrete surfaces the surface shall be cleaned with wire brush and scarified by lines with trowel or hacking done. The surfaces in both cases shall be washed properly and kept wet for 4 hours before plastering is commenced.

Plastering shall be started from top and gradually worked down towards the floor. It shall not at any place be thinner than specified. To ensure even thickness plaster of about 15 cm X 15 cm shall be first applied horizontally and vertically at not more than 2 metres intervals over the entire surface to serve as gauges. The surface of these gauges shall be truly in the plane of finished surface. The mortar shall then be laid in the wall or other surfaces between the gauges and finished even. All corners shall be rounded to a radius of 24 mm unless otherwise directed. The contractor shall not be paid for any extra thickness of plaster done than as specified.

**CONTRACTOR**

**ACCEPTING OFFICER**

Plaster, when more than 15 mm thick shall be applied in two coats, a base coat followed by the finishing coat. Thickness of the base coat shall be just sufficient to fill up unevenness in the surface, no single coat, however, shall exceed 12mm in thickness. The under coat shall be roughened or scratched before it is fully hardened.

Curing shall start 24 hours after the plaster is laid. It shall be kept wet for 14 days. During this period it shall be suitably protected from all damages at the contractor's cost by such means as approved by the Engineer-in-charge.

Any cracks which appear in the surface shall be cut out in rectangular shape and redone as directed by the Engineer-in-charge. Wherever specified standard waterproofing compound as approved by the Engineer-in-charge shall be added to the mortar at the rate of 2% or as specified by the manufacturer by the weight of cement for which the rate shall be paid separately. The rate for plastering shall include cost of scaffolding, swing etc., needed for the work with labour and material all complete.

#### **9. Steel Door, Windows and Ventilators :**

All steel doors, windows and ventilators shall conform to IS – 1038, IS – 1361 and IS 1081 or equivalent as mentioned in the bill of quantities and as approved by the Engineer-in-charge.

Rolled steel sections shall conform to Is – 226. The sections shall be cold straightened and finished goods shall be free from bends and other defects. Materials used in the fabrication shall be the best procurable and conforming to relevant IS specification. Thickness and specification of the glass to be provided shall be as indicated in the relevant item of the bill of quantities. Glass shall be free from flaws, specks, bubbles, etc., Bolts, nuts, screws, peg stays and other mild steel fittings shall be treated for corrosion as per relevant Indian Standards. Putty for glazing shall conform to IS – 420.

Doors, windows and ventilators, etc., shall be truly square and free from twist and warp. They shall be constructed of sections which have been cut to the required lengths and welded or rivetted at the corners as per standard specifications.

All steel surfaces shall first be thoroughly cleaned free of rust scale or dirt and mill scale by approved means and shall be painted with one coat of approved primer conforming IS – 102 before despatch. Alternatively if specified they may be galvanised by the "Hot dip" zinc spray or electro galvanising process described IS – 1361. Doors, windows and ventilators shall be fixed in positions, as specified under IS 1081.

Whenever contractor is required to supply the doors, windows and ventilators etc., he shall first submit to the Engineer-in-charge, the details about source of supply, detailed drawing and specifications etc., for prior approval.

#### **10. M.S Rolling Shutters :**

It shall be of approved quality, made out of 18 gauge 75 mm black laths mechanically operated by reduction gear type mechanism. It shall be fitted with two self-aligning ball bearing with locking arrangements (both inside and outside) including M.S pressed side guides bottom rails brackets and top rolling spring pressed etc., complete provided with locking arrangements for padlocks, pulling hooks, handles, top cover etc., It shall be painted with one coat of approved primer conforming to IS – 102 before despatch.

**CONTRACTOR**

**ACCEPTING OFFICER**

## **11. Wooden Doors, Windows and Ventilators :**

All wood work for doors, windows, ventilators cup board, shelves, etc., conform to relevant IS specification and TNBP 82 and shall be well seasoned teak wood or well seasoned country wood (pillamarudu or karumarudu) as the case may be. Timber shall be best quality and shall be free from knots, injurious open shales, bore holes, decay, soft or spongy spots, hollow pockets and all other defects and blemishes. Timber shall conform to IS 1003 (Part 1) 1966. Size of doors, windows and ventilators shall as specified in the relevant item of schedule and detailed drawings and generally in conformity with IS – 1003, part I and part II of 1966. The rates for doors, windows and ventilators etc., shall be for the finished work inclusive of fixing them in position with necessary iron hold fasts and furniture fitting of oxidized iron or aluminium or oxidized brass as stated in the description of the relevant items of the bill of quantities and as directed by the Engineer-in-charge. Fittings and furniture shall be of best quality and machine made and robust type. Wherever glazed shutters are to be provided, the cost of glass panes of specified thickness and fixing them in position should be included in the quoted rate. All glass shall be of superior quality from approved manufacturer. In case of solid core flush doors, they should conform to IS:2202 Part I and Part II. The flush door shutters should have a finished thickness as specified in the scheduled item. Flush door shutters shall be obtained from firms of repute as approved by the Engineer-in-charge.

## **12. ROOFING : (A) R.C.C Slabs :**

Roof slab shall be of RCC of specified mix conforming to IS : 456, with adequate main tensile, transverse and adhesive reinforcement of ribbed steel bars of mild steel rounds. Unless otherwise mentioned the rates for RCC slab shall include cost of concrete, centering and shuttering charges, vibration charges, rounding of corners, curing and finishing etc., complete. Expansion joints in reinforced cement slabs shall be as per TNBP 30.

The ceiling should be finished as per Clause 30 of TNBP. No extra payment shall be made towards cost of ceiling plaster necessitated on account of defective centering materials used or poor workmanship.

The top of roof slab shall be finished with weathering course treatment if so specified. The weathering course work shall conform to TNBP 44-HJ and consist of concrete with broken brick in neat slacked lime of specified thickness finished with one course of pressed split tiles / pressed tiles of specified thickness and size as described in the bill of quantities.

## **(B) Roofing and Side Cladding with A.C. sheets :**

The A.C. sheets shall be of specified and approved quality and shall conform to IS 459- 1962 in all respects. The sheet shall be laid with the smooth side upwards and with a minimum end lap of 15cm. and for every flatter slopes this should be 20cm. The laying operation shall include scaffolding works involved. Sheets shall be secured to the purlins by means of 8mm galvanized iron J or L hook bolts and nuts. The grip of the hook bolt on the side of the purlin shall be not less than 25mm. Each bolt shall have a bitumen washer and galvanized iron washer placed over the sheet before the nuts are screwed down from above. Hole for hook bolts etc., shall be drilled and not punched in the ridges of the corrugations in the exact positions. The diameter of these holes shall 1.5 mm more than the diameter of the fixing bolts. The payment will be square metre basis of the laid area.

## **13. A.C. Rain Water Pipes**

The pipes shall be of standard quality conforming to IS 1628 – 1960. These shall be straight, true smooth and regular in thickness. They shall be free from cracks and other flaws. The supply shall include all necessary pipe fittings and accessories.

**CONTRACTOR**

**ACCEPTING OFFICER**

All pipes shall be fixed to wall or columns by standard M.S butt holder clamps of approved make. The spigot of the upper pipe shall be properly fitted into the socket of the lower pipe, such that there is uniform annular space for filling with the jointing materials. One third depth of this annular space is to be filled with spun yarn soaked in bitumen of approved quality and properly pressed with caulking tool. The remaining two, third depth of the joint is to be filled with Cement Mortar 1:2 ( 1Cement : 2 coarse sand) and shall be pressed with caulking tool and finished smooth at the top at an angle of 45 Deg. sloping up.

The rate shall include supplying and fixing pipes with specials and accessories, including sizing as required, jointing, testing, cutting of walls and making good necessary scaffolding etc., complete.

#### **14. Flooring :**

Flooring shall consist of a base course of cement concrete of specified thickness and proportion laid over the compacted earth or sand filling as specified and a finishing layer of concrete, mosaic, glazed tiles or any other material as specified to be laid. Flooring work for Factory shop floors as well as mosaic flooring shall be done as per the special specifications.

The bed flooring shall be prepared either level or sloped as per relevant drawing or as instructed by the Engineer-in-charge. Filling in basement with earth or sand shall be in accordance with TNBP 25. On the prepared bed, cement concrete of specified mix and thickness shall be laid and well consolidated.

#### **A. Ellispattern, 1<sup>st</sup> Sort Flooring**

On the clean wet surface of the concrete base before it has set, will be laid a layer of cement concrete to give a finished depth of 20/25 mm over the base concrete. The cement concrete will be of 1:3 proportion (one cement and 3 hard broken stone chippings 3 to 10 mm Size). To make a coloured floor red oxide iron powder or other approved materials should be mixed with cement at the rate 10% of the weight of cement or as directed by the Engineer-in-charge. Ellis pattern flooring shall be done as described under clause 41-G of TNBP.

#### **B. Glazed Tile Flooring**

The tiles shall be of ceramic white or coloured and of specified dimensions as described in the schedule item. The top surface of tiles shall be glazed with a neat finish of uniform colour and texture and free from flaws, cracks, craze, specks or other imperfections. Tiles shall be true and shape with straight edges, non-absorbing and non – fading. Samples of tiles together with manufacturer's literature shall be submitted to the Engineer-in-charge for approval. Tiles shall conform to IS 177 latest.

Over the prepared surface of the floor a bedding layer of Cement Mortar (1:3) of specified thickness shall be laid-in-proper level and slope using screed patterns. The bedding layer shall be deeply scratched while it is set. A mortar set bed of 6mm thickness in cement lime mortar 1:1:3 ( one cement one lime putty and three sand ), shall be laid over the bedding layer. After mortar setting, bed has been leveled, a skin of neat cement shall be trowelled to the mortar setting bed immediately before the tiles are set. As soon as the mortar setting bed has sufficiently hardened, all tiles shall be finally secured in place and gently beaten in and finished surface brought to desired level. When grouting the glazed tiles, special care shall be taken to prevent scratching of the glazed surface. Joints shall be pointed with white or coloured cement to match the tile surface and cured. No joint shall be more than 1.5 mm thick.

**CONTRACTOR**

**ACCEPTING OFFICER**

## **15. White Washing and Colour Washing**

White washing and colour washing shall be done as per clauses 63 and 64 of TNBP. The surface shall be thoroughly cleaned off mortar drops and foreign matter. All patchings must be scraped properly. The white washing shall be done from pure shell lime. Samples of lime shall be got approved by the Engineer-in-charge. The wash shall be applied with a brush, the coats being laid on vertically and horizontally alternatively, each coat being allowed to dry before next coat is applied. For colour washing the desired shade shall be obtained by mixing approved quantity of colouring matter or distemper with shell lime solution and applied as per white. The contractor shall take every precaution to prevent white wash being splashed on wall, floor and other places and articles not to be white washed. No colour wash shall be done unless a sample pattern of the mixed colour has been approved by the Engineer-in-charge. The rates shall be inclusive of scaffolding charges, cost of ladder etc.,

## **16. Painting**

All painting work shall be done in accordance with TNBP-66 and the relevant Indian Standard Specifications. Paints, varnishes, cement paints etc., shall be the highest grade products of well known approved manufacturer and shall be delivered to site in original sealed containers. It is desired that materials of one manufacturer only shall be used as far as possible. Colours shall be uniform and nonfading. Samples of all colours selected shall be submitted to the Engineer in charge for approval before bulk purchase is made. All finished work shall match corresponding samples kept with the Engineer.

### **Preparation of Surface :**

Before painting wooden surfaces, protruding timber fibres shall be removed and nail marks shall be covered with putty. The surface shall be thoroughly cleaned and sand prepared. In case of steel work it shall be scraped, well brushed and cleaned free of rust, scale dirt. Base preparation for painting concrete, masonry and plastered surfaces shall be carried out as per IS 2395 – Part I of 1966. Before actually proceeding with the work of painting the concrete, masonry and plastered surfaces, it shall be verified that the surfaces shall be completely dry, free from efflorescence and alkaline effect.

### **Application**

The primer shall be applied with brushes and spread as evenly and as smooth as possible. For steel work a priming coat of anti corrosive paint shall be applied. Painting shall be done by skilled labourers in a work-man like manner. All coats shall be of proper consistency and shall be well brushed out, so that no brush marks are visible. The under coating should be nearest to the specified colour of the finishing coat. Unless otherwise specified ready mixed synthetic enamel paints shall be used for painting, wood and steel work. Under coats should be completely dry before finishing coat is taken up. Priming coat and under coat shall be rubbed with sand paper and dusted clean. The finished coat of approved paint shall then be applied.

## **17. Cement Painting**

Cement Paint solution shall be applied to the surface with hair brushes in a number of coats to get uniform finish. After the first coat of paints has hardened, it shall be cured with water atleast for 24 hours. The surface shall be wetted again before the application of the second coat. Atleast 24 hours should lapse between the two coats, number of coats shall be as specified in the schedule of quantities. It shall be kept damp atleast for seven days.

**CONTRACTOR**

**ACCEPTING OFFICER**

## 18. French Polish

French polish to be used shall comply with IS 348. Polishing shall be obtained by dissolving 1 lbs. of shellac in one gallon of methylated spirit without applying any source of heat. After the shellac has dissolved  $\frac{1}{4}$  lbs of cobalt,  $\frac{1}{4}$  lbs of lobano and 0.4 oz of crystals of desired pigment shall be added. The solution shall be applied with a pad of fine muslin cloth tied as per general practice. The pad shall be dipped into the solution and wrung with fingers and be rubbed hard on the surface in this way, the first coat is to be given after this gets dried up, the successive coats shall be given in the same fashion till the mirror like surface is obtained. The wood to be polished shall be first applied with a filler composed of 1.25 Kg. of whiting mixed with one litre of methylated spirit and then sand papered when dry. The finished surface shall have uniform texture and gloss. Approved transparent sealer shall only be used in base preparation.

CONTRACTOR

ACCEPTING OFFICER

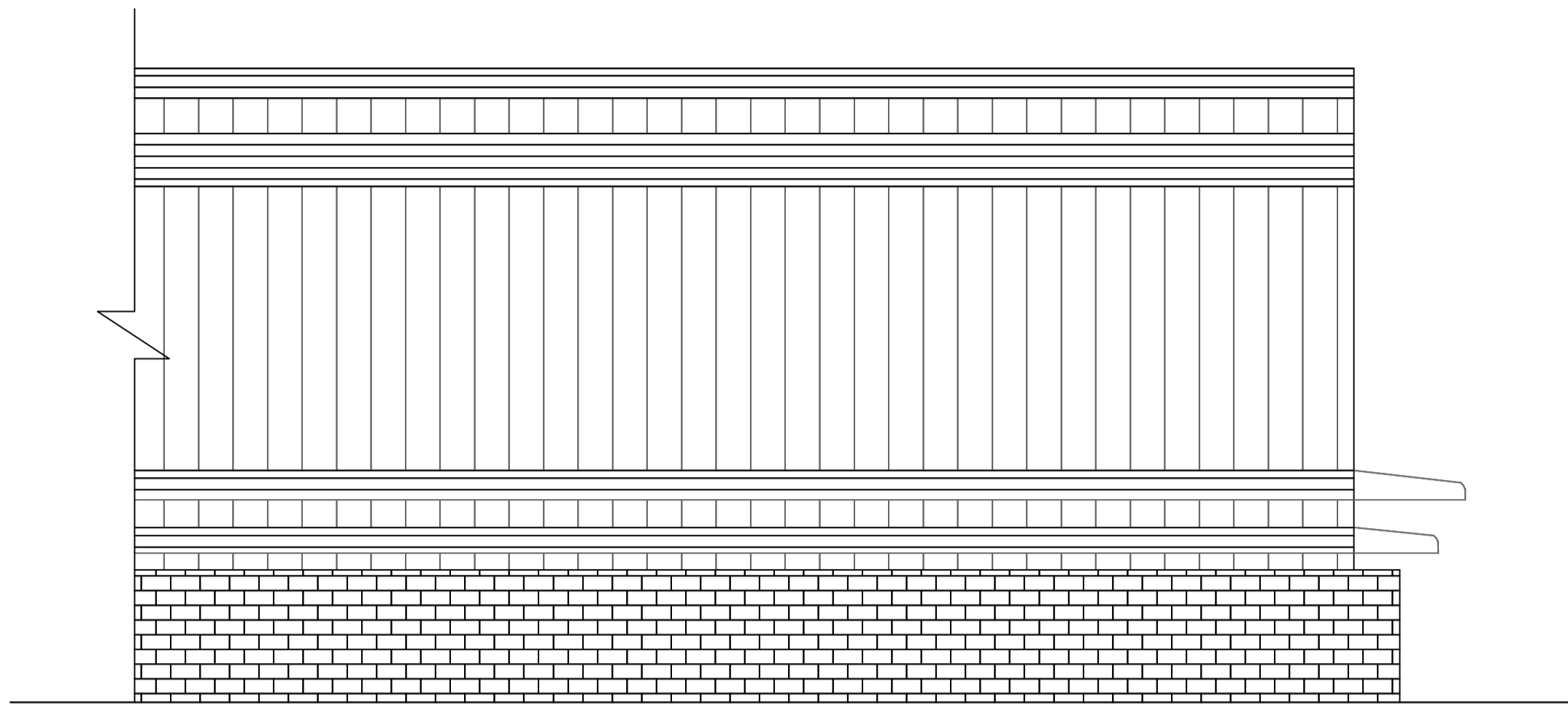

SIDE ELEVATION

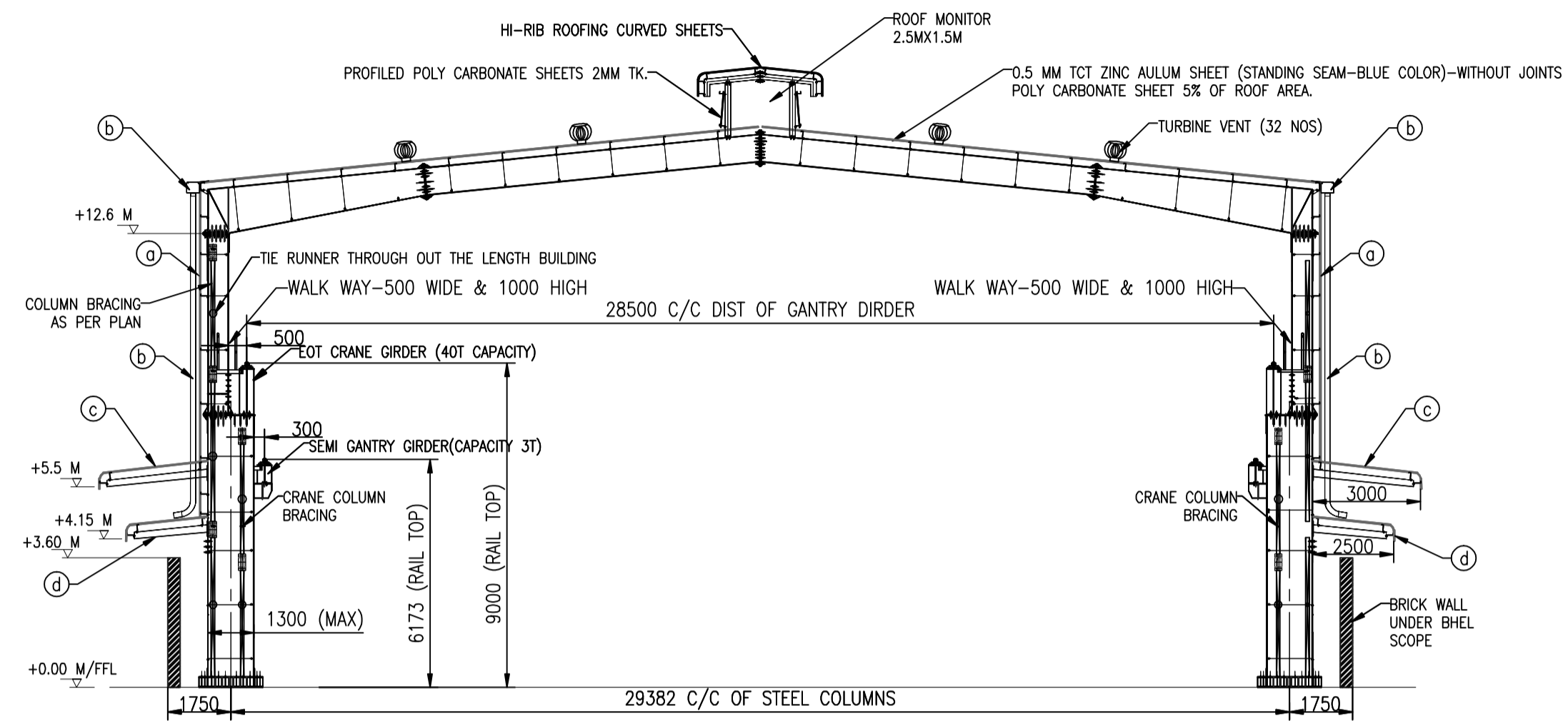

SECTION AA

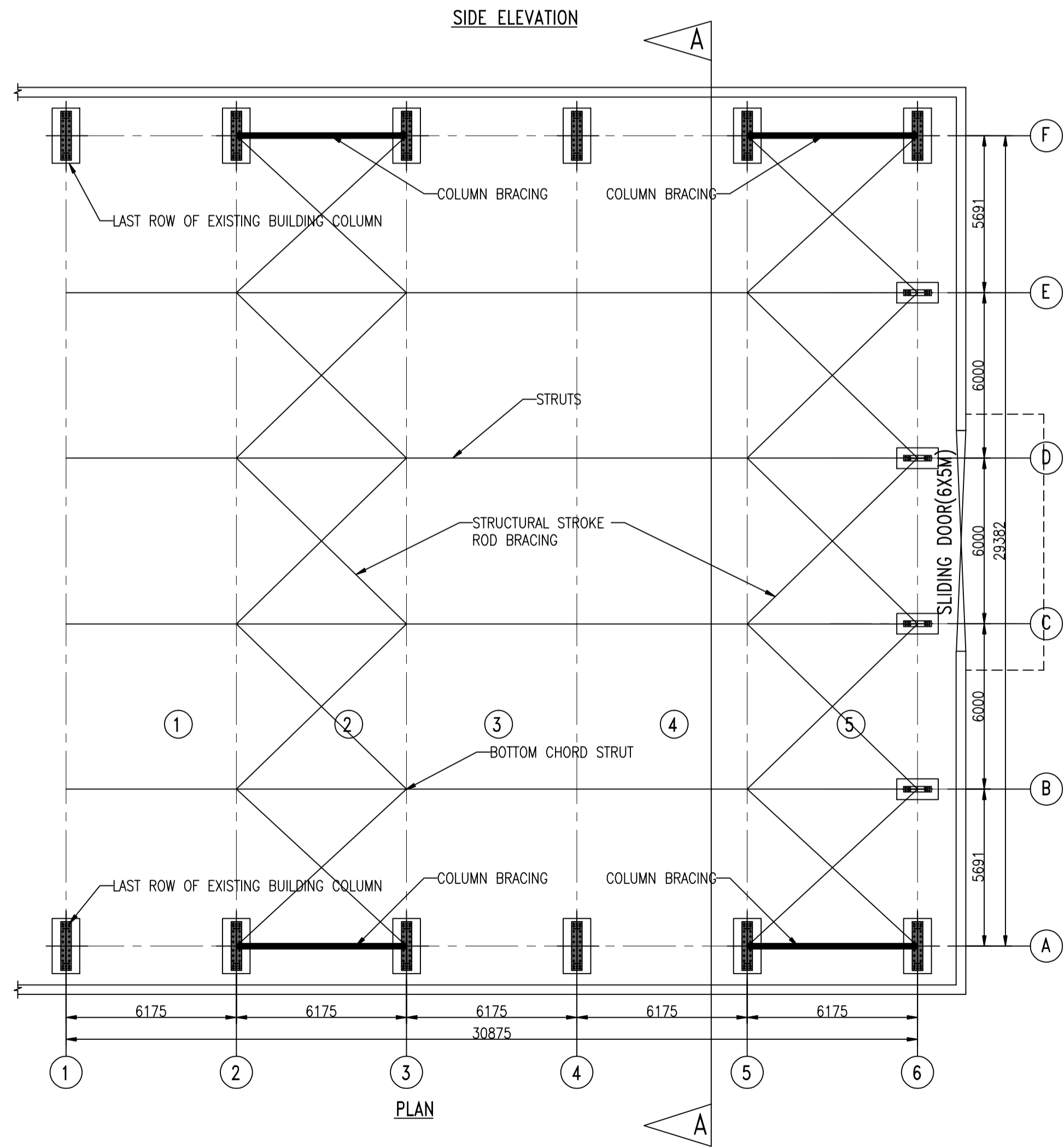

PLAN

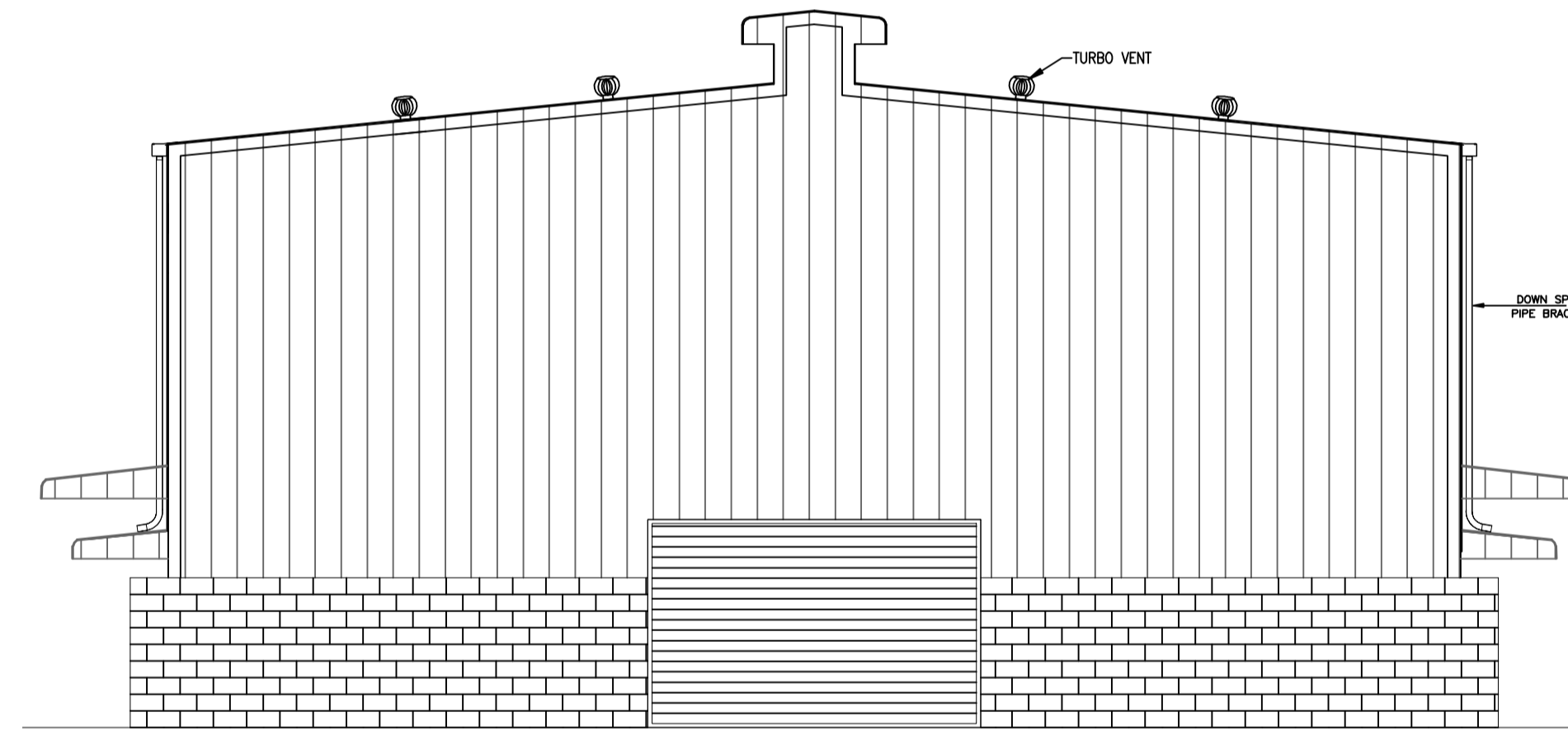

FRONT ELEVATION

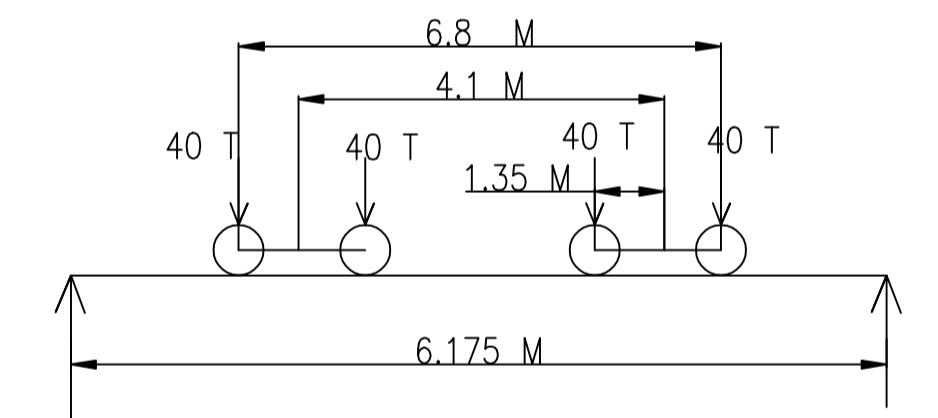

100 TONNE CRANE WHEEL LOAD DATA

SPECIFICATION

- a. 0.5MM TCT COLOR COATED GALVALUME SHEET (TRAPEZOIDAL PROFILE)
- b. EAVES GUTTER & DOWN TAKE PIPES: IN COLOR ZINC-AULUM SHEETS
- c. 1 NOS-CANOPY 7.5MX3M PROJECTION OVER OPENING WITH CURVED EAVE AND END CLOSING
- d. CONTINUOUS LOUVER 2.5M PROJECTION WITH CURVED EAVE AND END CLOSING

NOTES:

1. DESIGN AS PER IS-800:2000
2. E.O.T- 100 TONNE CAPACITY
3. SEMI GANTRY-3 TONNE CAPACITY
4. TURBO VENT -20 NOS
5. POLYCARBONATE SHEET 5% OF ROOF AREA
6. POLYCARBONATE SHEET FOR ROOF MONITOR
7. ALL MAIN MEMBERS 345 Mpa YIELD STRENGTH & CRANE GIRDERS
8. SLIDING DOOR- 1 NOS (7MX6M)
9. GALVANIZED PURLIN
10. EPOXY PAINTING

FOR TENDER PURPOSE ONLY

REV	DATE	ALTERED/CHECKED	CUSTOMER: FACTORY	DWG NO:	SIZE:	SCALE:
			BHARAT HEAVY ELECTRICALS LTD. UNIT: BOILER AUXILIARIES PLANT. RAJAPET - 632 406.	SHEET 1 OF 1	A1-L	1:150
				NAME	SIGN	DATE
				DRN S.R.BRITTO		31.08.09
				CHD S.RAMESH		31.08.09
				APD C.C.DURAI		31.08.09
TITLE: GA OF FABRICATION BAY EXTN.				DWG NO:	REV	
				BHE-BAP-C10-1707	00	

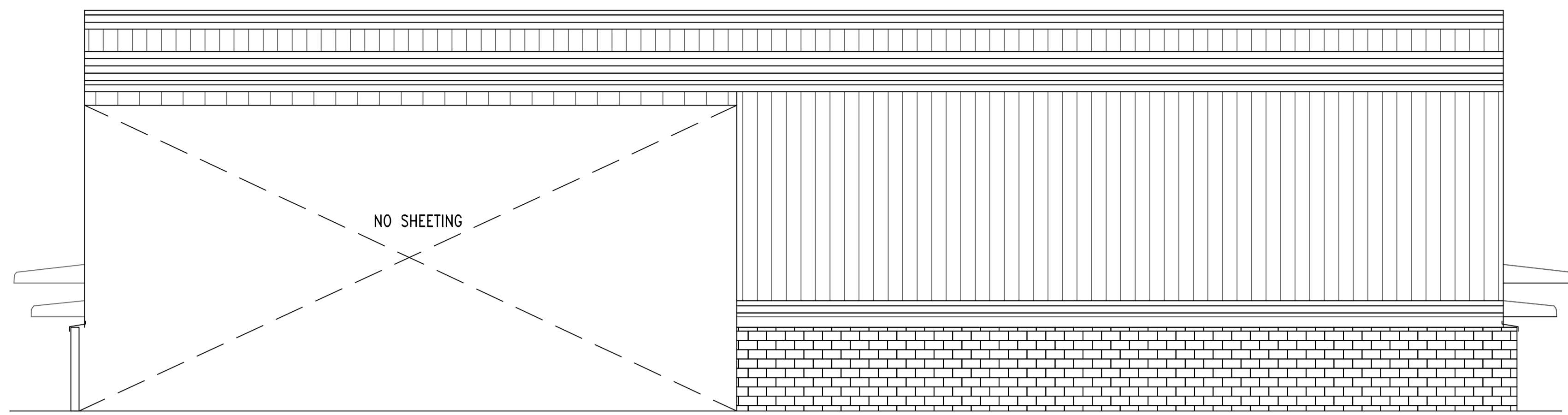

VIEW-B

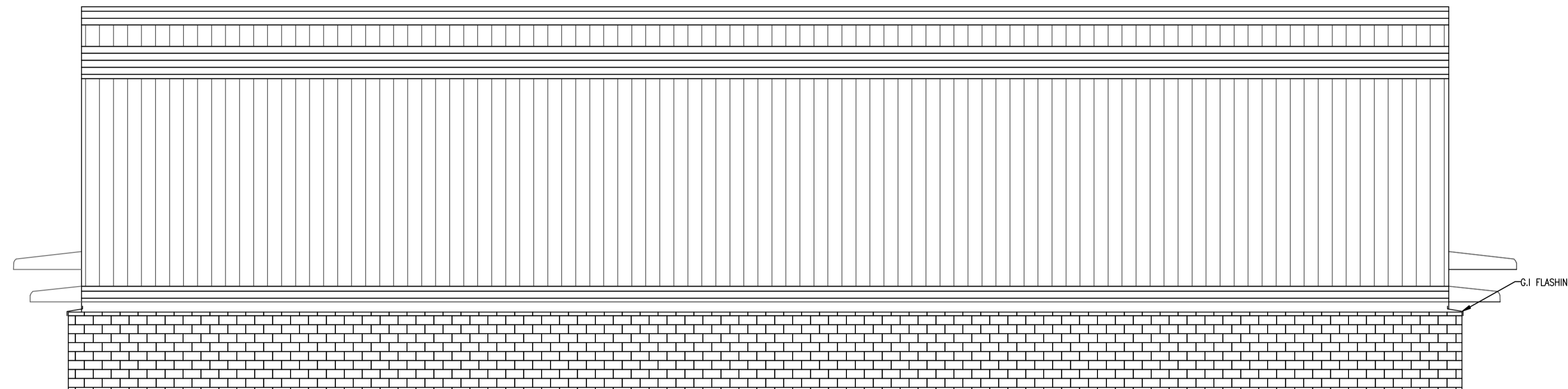

VIEW-A

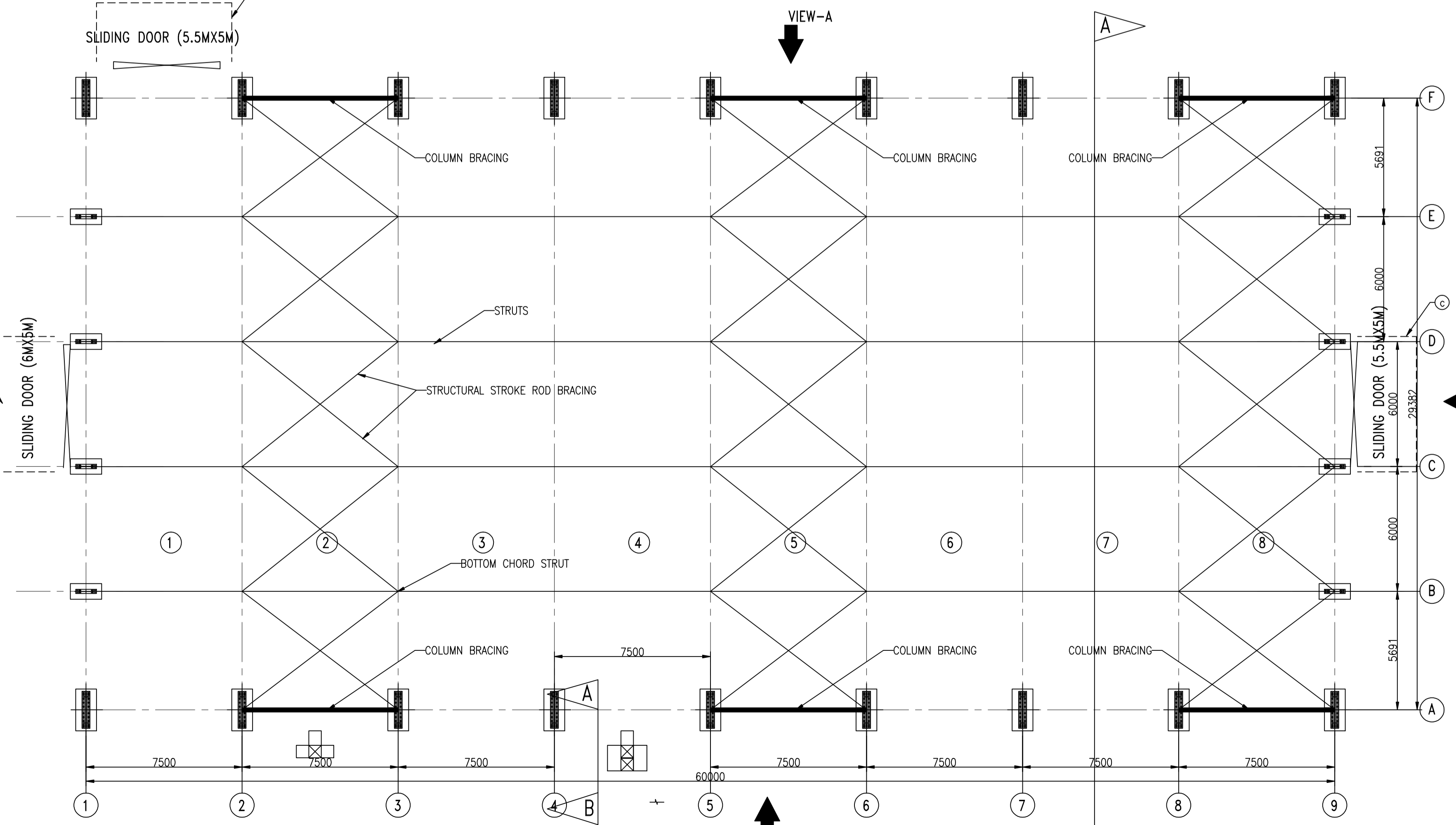

PLAN

VIEW-B

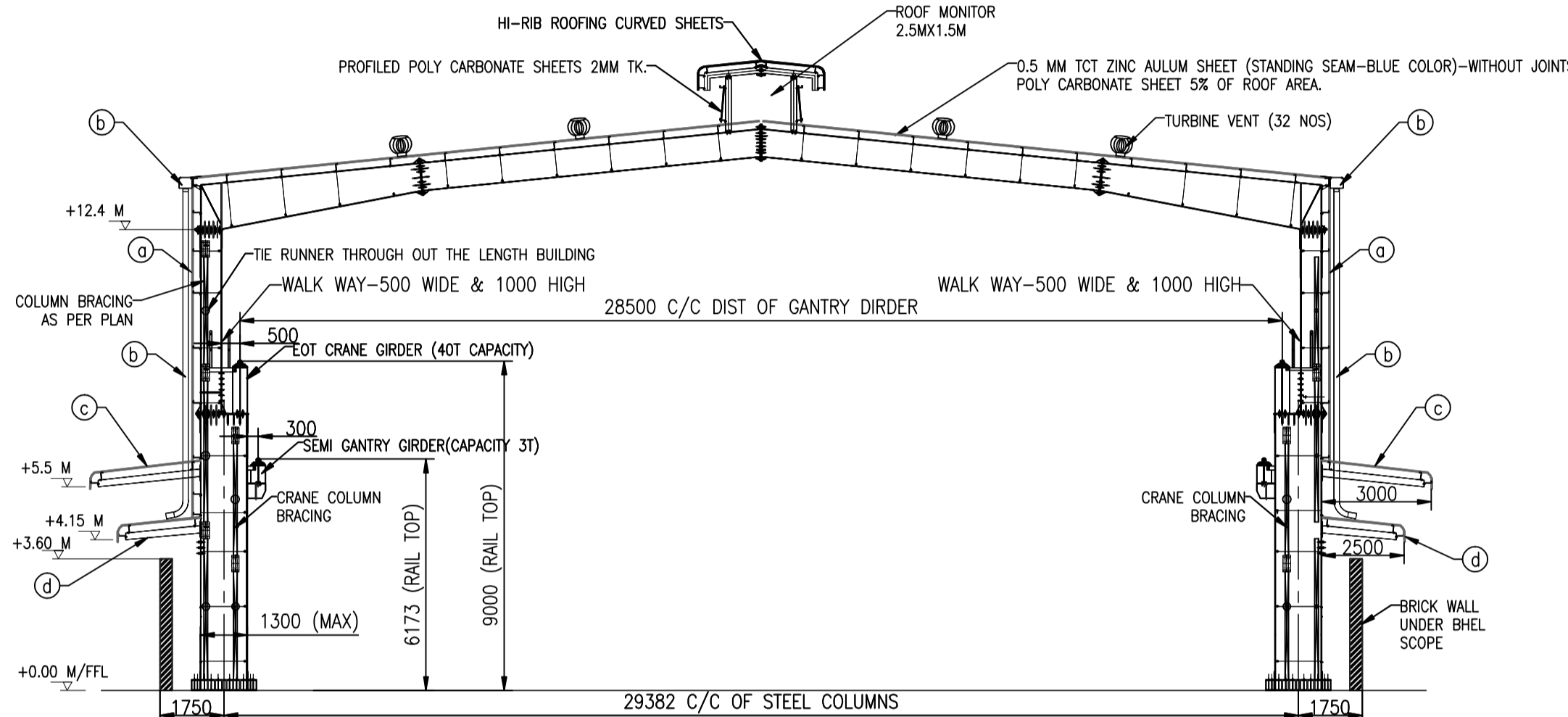
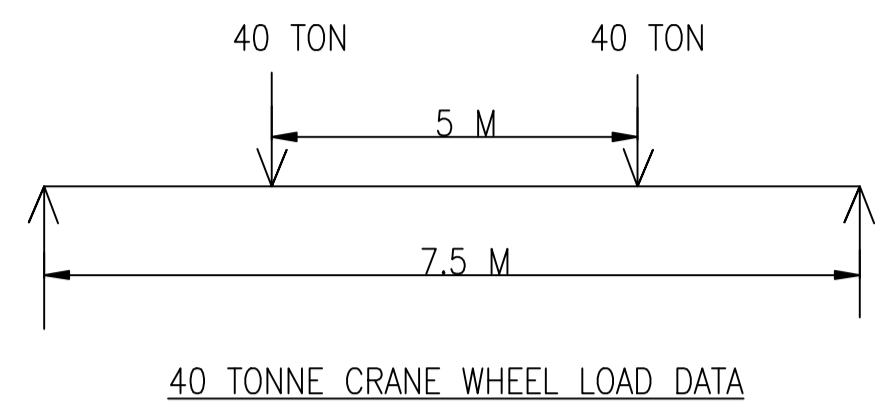
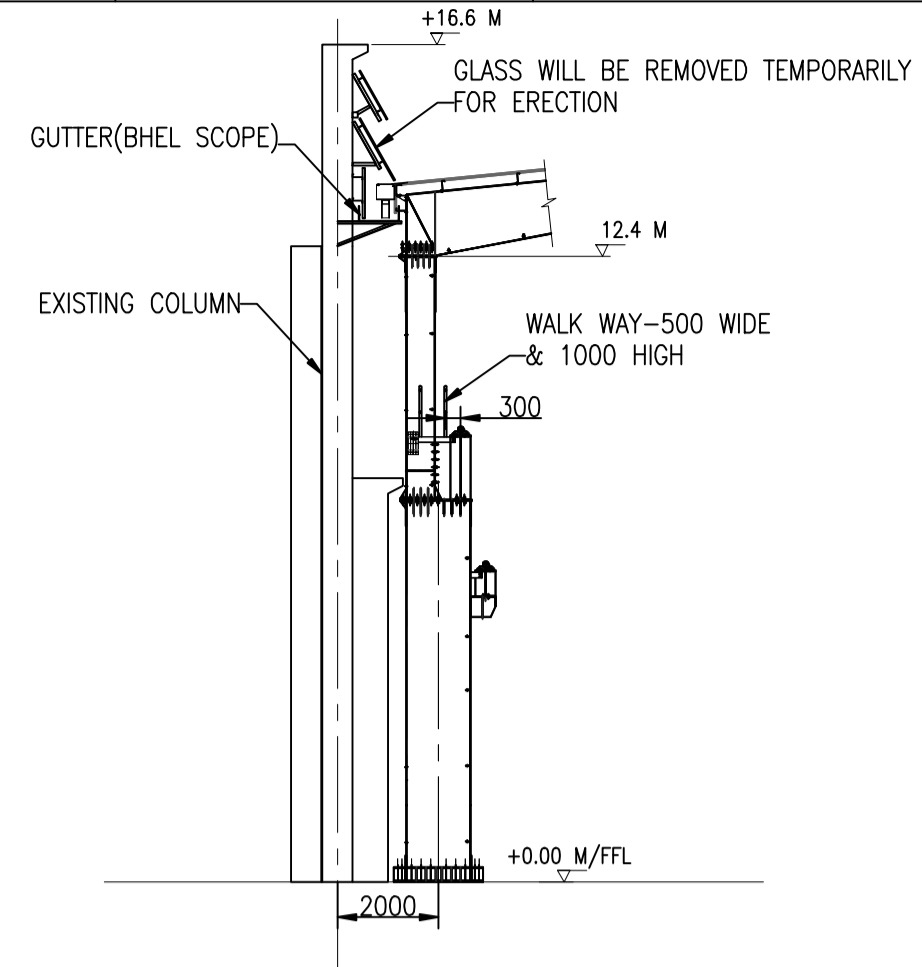

SECTION AA

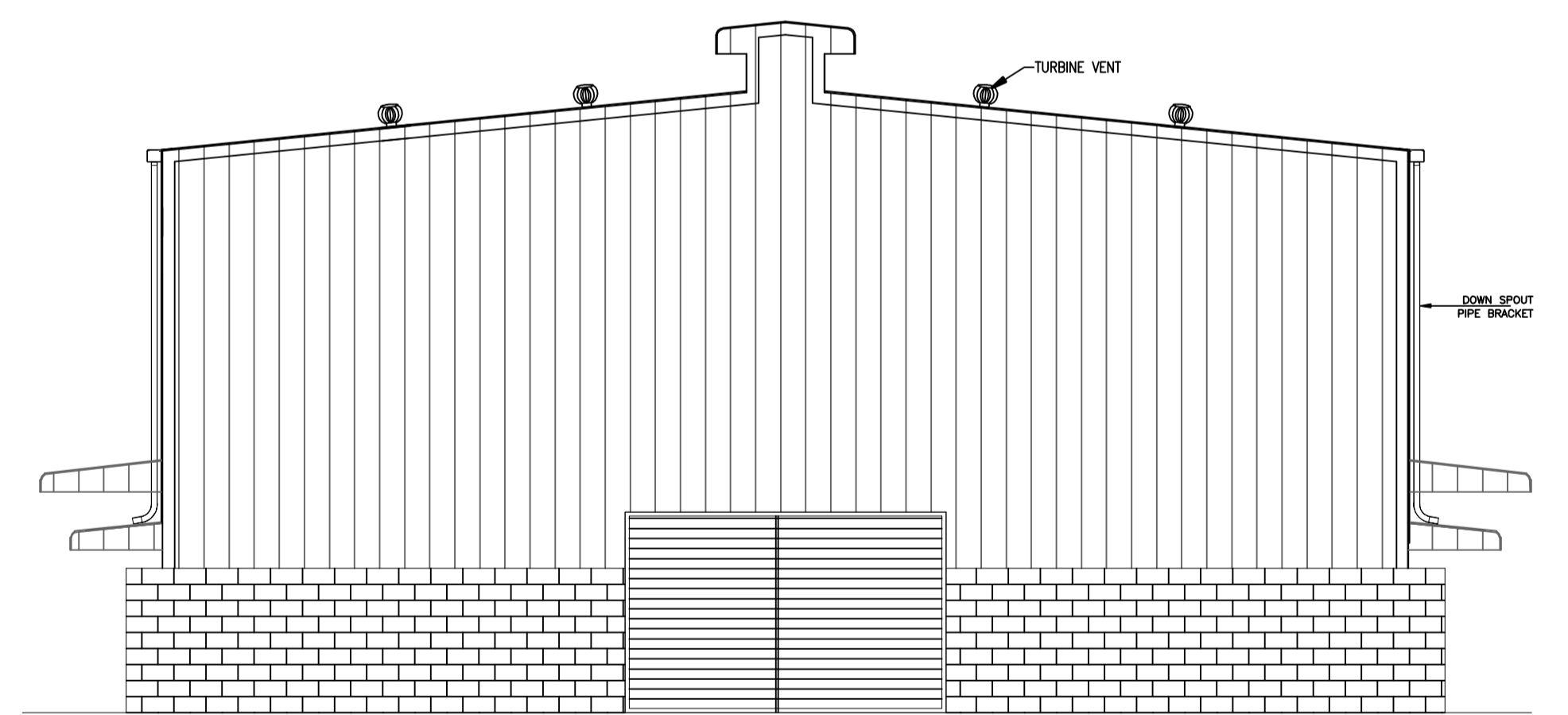

VIEW-C

SPECIFICATION

- a. 0.5MM TCT COLOR COATED GALVALUME SHEET (TRAPEZOIDAL PROFILE)
- b. EAVES GUTTER & DOWN TAKE PIPES: IN COLOR ZINC-AIUM SHEETS
- c. 3 NOS-CANOPY 6MX3M PROJECTION OVER OPENING WITH CURVED EAVE AND END CLOSING
- d. CONTINUOUS LOUVER 2.5M PROJECTION WITH CURVED EAVE AND END CLOSING

NOTES:

1. DESIGN AS PER IS-800:2007
2. E.O.T- 40 TONNE - 1 NO
3. SEMI GANTRY-3 TONNE - 1 NO
4. TURBINE VENTILATORS - 32 NOS
5. POLYCARBONATE SHEET 5% OF ROOF AREA
6. POLYCARBONATE SHEET FOR ROOF MONITOR
7. ALL MAIN MEMBERS 345 Mpa YIELD STRENGTH & CRANE GIRDERS
8. SLIDING DOOR- 3 NOS
9. GALVANIZED PURLIN
10. EPOXY PAINTING

FOR TENDER PURPOSE ONLY

REV	DATE	ALTERED/CHECKED	CUSTOMER: FACTORY	DWG NO:	SIZE:	SCALE:
			BHARAT HEAVY ELECTRICALS LTD. UNIT: BOILER AUXILIARIES PLANT. RAJNLET - 632 406.	SHEET 1 OF 1	A1-L	1:150
			<small>CAUTION: The information on this document is the property of BHARAT HEAVY ELECTRICALS LTD. It must not be used directly or indirectly in any way detrimental to the interest of the company.</small>	NAME	SIGN	DATE
				DRN S.R.BRITTO		31.08.09
				CHD S.RAMESH		31.08.09
			APD C.C.DURAI		31.08.09	
TITLE: GA OF WELDING TECHNOLOGY CENTRE				DWG NO:	REV	
				BHE-BAP-C10-1706	00	

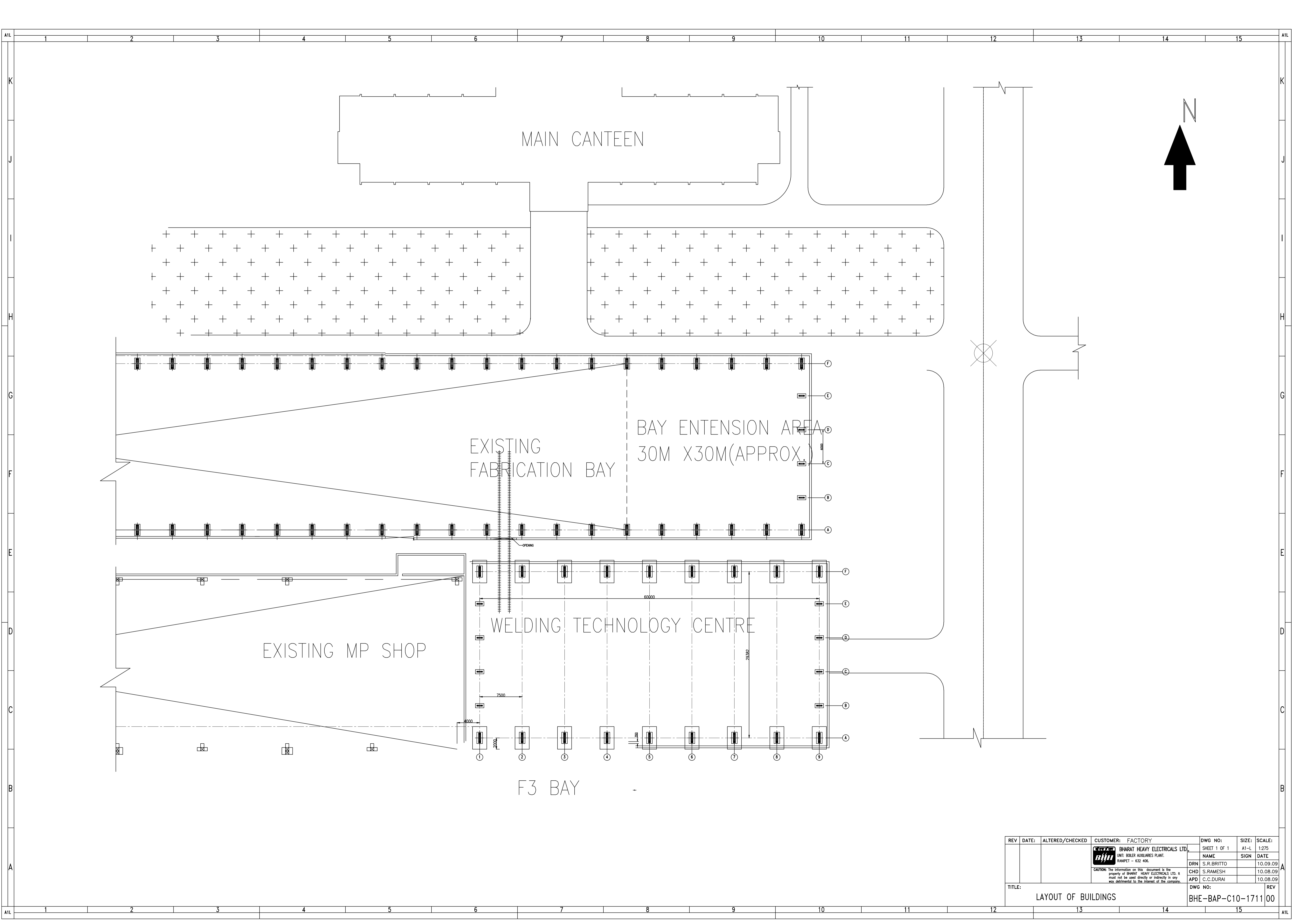

MAIN CANTEEN

EXISTING FABRICATION BAY

BAY EXTENSION AREA  
30M X 30M (APPROX.)

EXISTING MP SHOP

WELDING TECHNOLOGY CENTRE

F3 BAY

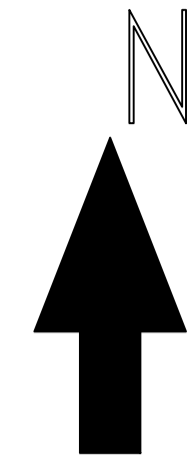

REV	DATE	ALTERED/CHECKED	CUSTOMER: FACTORY	DWG NO:	SIZE:	SCALE:
			BHARAT HEAVY ELECTRICALS LTD. UNIT: BOILER AUXILIARIES PLANT. RAJAPET - 632 406.	SHEET 1 OF 1	A1-L	1:275
			 <b>BHEL</b>	NAME	SIGN	DATE
			<small>CAUTION: The information on this document is the property of BHARAT HEAVY ELECTRICALS LTD. It must not be used directly or indirectly in any way detrimental to the interest of the company.</small>	DRN S.R.BRITTO		10.09.09
				CHD S.RAMESH		10.08.09
				APD C.C.DURAI		10.08.09
TITLE: LAYOUT OF BUILDINGS				DWG NO:	REV	
				BHE-BAP-C10-1711	00	