

LIST OF BUILDING/EQUIPMENT SHOWN

S.No.	ZONE	DESCRIPTION
1	D-8	ACC
2	C-8, D-8 & E-8	ACC CONDENSATE STORAGE TANK
3	C-8, D-8 & D-8	ACC MCC ROOM
4	C-8, D-8 & D-8	ACC VACUUM HOGGING PUMP HOUSE
5	D-4	ACV CARTRIDGE DISSOLVE DOSING SYSTEM
6	D-5	ACV COOLING TOWER
7	D-9	ACV PUMP HOUSE
8	D-4	ACV TREATMENT SYSTEM
9	D-5	AUX BOILER
10	C-7, D-7 & E-7	BOILER
11	D-4	CHEMICAL LAB
12	D-6, D-6 & E-6	CHIMNEY
13	CHP	CHP
14	E-7	CONDENSATE STORAGE TANKS
15	E-7	CONDENSATE TRANSFER PUMP HOUSE
16	D-4	CPU REGEN. BUILDING
17	C-7, D-7 & E-7	ESP
18	C-6, D-6 & D-6	ESP CONTROL ROOM
19	E-4	ETP
20	F-5	FD - FARM AREA CHFD, LDD, DOT)
21	D-7	FD - FUEL OIL PUMP HOUSE
22	D-5	FD - OIL TANKER UNLOADING
23	E-10	H2 GEN. PLANT
24	E-8	MAIN PLANT & MRS COMPRESSOR HOUSE
25	C-7, D-7 & D-7	MRS
26	D-4	RAW WATER PUMP HOUSE
27	E-3	STP
28	D-9	SWITCHYARD
29	D-7, D-7 & E-7	TG BUILDING
30	D-8, D-8 & E-8	TRANSFORMER YARD
31	E-3	WEIGH BRIDGE
32	H-6	AHP BA & FA SILO MCC
33	D-7, D-7 & E-7	AHP BOTTOM ASH CONVEYER
34	D-7, D-7 & E-7	AHP BOTTOM ASH SILO
35	D-6	AHP COMPRESSOR HOUSE-1
36	C-6	AHP COMPRESSOR HOUSE-2
37	D-6	AHP FLY ASH INTERMEDIATE SILO
38	H-6	AHP FLY ASH SILO
39	E-9	MISC. SWITCH GEAR BLDG.
40	F-11	CHP- LDCO SHED
41	H-5	SILO UTILITY BLDG.
42	E-5	CHP-COAL CONVEYER
43	F-4, F-4	CHP-COAL STOCK PILE A,B,C,D
44	G-4	CHP-CRUSHER HOUSE
45	-	-
46	-	-
47	G-5	CHP-PUMP HOUSE-A CON GROUND FLR OF LS CRD
48	E-5	CHP HOUSE-B
49	E-5	CSSP
50	F-3	DOZER SHED
51	D-6	LHP - GYPSUM DEWATERING BUILDING
52	E-6	LHP - LIMESTONE CRUSHER HOUSE
53	E-5	LHP - TEMPORARY GYPSUM STORAGE SHED
54	D-4	DM PLANT
55	D-5	DM PLANT - ACID ALKALIE STORAGE
56	D-5	DM PLANT N-PIT & BACKWASH
57	D-6, D-6 & E-6	FDG - ABSORBER
58	-	-
59	D-6, D-6	COMMON FCB C. ROOM & ESP CONTROL ROOM UNIT-2
60	D-4	PT CHEMICAL HOUSE
61	D-4	PT CLARIFIER
62	D-4	PT PLANT
63	D-4	DM TANKS
64	C-5	ADMN BUILDING
65	F-5	AMMONIA STORAGE
66	C-5	AUDITORIUM
67	C-6	CANTEN
68	D-8	DG SETS
69	D-8 & D-8	FIRE FIGHTING - DRILL TOWER
70	D-5	FIRE FIGHTING - FIRE STATION
71	D-7	FIRE FIGHTING - FIRE WATER BOOSTER PUMP HOUSE
72	D-5	FIRE FIGHTING - FIREWATER PUMP HOUSE
73	D-5	FIRE FIGHTING - FIREWATER TANKS
74	D-5	FIRE FIGHTING - FOWMING PUMP HOUSE
75	E-4	FGA BUILDING
76	D-5	IT BUILDING
77	C-5	GATE COMPLEX
78	D-4	OPEN STORAGE YARD
79	D-5	OWNERS OFFICE
80	C-5	SAFETY PARK
81	E-5	OWNERS STORES (CONSTRUCTION)
82	E-4	STORES (CMP)
83	C-5	TIME OFFICE
84	E-3	WORKSHOP
85	-	-
86	E-7	AHP MCC-1 (SWITCHEAR CUM DCS ROOM)
87	D-7	AHP MCC-2 (SWITCHEAR CUM DCS ROOM)
88	D-7	AHP MCC-3 (SWITCHEAR CUM DCS ROOM)
89	D-6	AHP MCC-4 (SWITCHEAR CUM CONTROL ROOM)
90	H-5	AHP MCC-5 (SWITCHEAR CUM DCS ROOM)
91	H-6	CHP MCC-1 (SWITCHEAR CUM DCS ROOM)
92	G-7	CHP MCC-2 (SWITCHEAR CUM DCS ROOM)
93	-	-
94	G-4	CHP MCC-4 (SWITCHEAR CUM CONTROL ROOM)
95	E-4	CHP MCC-5 (SWITCHEAR CUM DCS ROOM)
96	E-6	CHP MCC-6 (SWITCHEAR CUM DCS ROOM)

SPECIAL NOTE:
 PLANT GRIDS ARE ROTATED AT AN ANGLE OF 44° COUNTER CLOCKWISE AND COMMON POINT OF ROTATION IS 1000E,1000N AS PER NEW GRID SYSTEM AND 325640E,2615460N AS PER OLD GRID SYSTEM (SURVEY GRID) AS SHOWN IN THE DRAWING.

LEGEND:

1.	ROADS (DOUBLE LINE)	---
2.	ROADS (SINGLE LINE)	---
3.	EXISTING FACILITIES/BUILDING	---
4.	OWNER'S LAND BOUNDARY LINE	---
5.	SLOPE LINE	---
6.	BOUNDARY WALL (2.1M HIGH BRICK WORK) FOR ISOLATION OF EXISTING STATION	---
7.	PIPE CUM CABLE TRESTLE (PEM)	---
8.	CABLE TRESTLE (PEM)	---
9.	CONSTRUCTION LIGHTNING MAST	○

REFERENCE DRGS:

SL No.	TITLE	DRG. NUMBER	SCOPE
1	REFERENCE PLOT PLAN	9585-999-POC-F-001	NTPC

NOTES:-
 1. ALL DIMENSIONS ARE IN MM & ELEVATIONS IN METERS UNLESS STATED OTHERWISE.
 2. FINISH FLOOR LEVEL = RL (+)375.50 M,CORRESPONDS TO PLANT EL. 0.0M (GROUND FLOOR OF STG BUILDING) FINISHED GROUND LEVEL OF BOP AREAS AS MARKED.
 3. LOCATION/SIZE OF BOP FACILITIES IS TENTATIVE ONLY

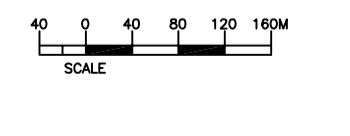

JOB NO. 434
 STATUS CONTRACT
 DISTRIBUTION

NTPC DRG NO.: 9585-001-999-POC-F-001

CUSTOMER
NTPC LIMITED

3x800MW PATRATU SUPER THERMAL POWER PROJECT

BHARAT HEAVY ELECTRICALS LTD
 POWER SECTOR
 PROJECT ENGINEERING MANAGEMENT
 NOIDA

REV. DATE ALT D CHD APPD
 1 27.09.2018 BC BSA JJ
 2 16.07.2018 BC BSA JJ

DEPT. NAME SIGN DATE
 H CHD BSA 26.03.2018
 H CHD BSA 26.03.2018
 H APPD JJ 26.03.2018

TITLE
PLOT PLAN

DEPT. SCALE 1:425 DRAWING NO. PB-DG-434-100-M001
 SIGN SHEET 1 OF 1 REV. 1 SIZE-A0

COPY RIGHT AND CONFIDENTIAL. BHARAT HEAVY ELECTRICALS LIMITED. The information on this document is the property of BHARAT HEAVY ELECTRICALS LIMITED. It must not be used directly or indirectly in any way detrimental to the interest of the company.

COMPUTER FILE NAME: ALI.MWI

	3x800 MW PATRATU TPS GYPSUM DEWATERING EQUIPMENT TECHNICAL SPECIFICATION MASTER DRAWING LIST WITH SCHEDULE OF SUBMISSION	SPECIFICATION No: PE-TS-434-571-A901	
		SECTION : I	
		SUB-SECTION : D	
		REV. 00	
		SHEET 1 OF 6	

SECTION-I

SUB-SECTION-D

ANNEXURE-V

MASTER DRAWING LIST WITH SCHEDULE OF SUBMISSION

	3x800 MW PATRATU TPS	SPECIFICATION No: PE-TS-434-571-A901	
	GYPSUM DEWATERING EQUIPMENT	SECTION : I	
	TECHNICAL SPECIFICATION	SUB-SECTION : D	
	MASTER DRAWING LIST WITH SCHEDULE OF SUBMISSION	REV. 00	
		SHEET 2 OF 6	

Drawings/Drawings to be submitted by the bidder

SN	Doc / Drawing No.	Drawing Title	Remarks		No. of weeks from LOI
			Type*		
1	PE-V0-468-571-A901	Sub-Vendor List of Components for GDE.	Primary	Basic Engineering drawings/ Documents (Primary drawings/ documents)	4
2	PE-V0-468-571-A902	Manufacturing Quality plan of GDE	Primary		4
3	PE-V0-468-571-A903	P & I Diagram with Bill of quantity (BOQ) of GDE.	Primary		3
4	PE-V0-468-571-A904	Control Philosophy of GDE.	Primary		6
5	PE-V0-468-571-A905	Design Philosophy of complete GDE.	Primary		3
6	PE-V0-468-571-A906	General Arrangement Drawing of Gypsum Dewatering Equipment (Showing layout of all the equipments of GDE in the building)	Primary		6
7	PE-V0-468-571-A907	Sizing calculations of (a) VBF, (b) Vacuum Receiver, (c) Vacuum Pump, (d) Belt Wash Pump, (e) Cake wash Pumps, (f) Drives and (g) other Accessories for GDE.	Primary		3
8	PE-V0-468-571-A908	General Arrangement Drawings of VBF including cross-sectional details, foundation plan and load details.	Primary		6
9	PE-V0-468-571-A909	Datasheet of Vacuum Belt Filter & all accessories of GDE.	Primary		8
10	PE-V0-468-571-A910	Piping Layout (Integral-Vendor Scope) with supports & fixing arrangement with BOQ for GDE.	Primary		10
11	PE-V0-468-571-A911	Piping Layout (Non Integral - BHEL Scope) with supports & fixing arrangement with BOQ for GDE.	Primary		10
12	PE-V0-468-571-A912	Instrument schedule along with GA & Data sheet for GDE.	Secondary		
13	PE-V0-468-571-A913	Data Sheet of Instruments of GDE	Secondary		
14	PE-V0-468-571-A914	Valve schedule for GDE.	Secondary		
15	PE-V0-468-571-A915	GA & Data sheet of Valves for GDE.	Secondary		

		3x800 MW PATRATU TPS GYPSUM DEWATERING EQUIPMENT TECHNICAL SPECIFICATION MASTER DRAWING LIST WITH SCHEDULE OF SUBMISSION		SPECIFICATION No: PE-TS-434-571-A901	
				SECTION : I	
				SUB-SECTION : D	
				REV. 00	
		SHEET 3 OF 6			
16	PE-V0-468-571-A916	Piping Isometric (Integral-Vendor Scope) with supports & fixing arrangement with BOQ for GDE.	Secondary		
17	PE-V0-468-571-A917	Piping Isometric (Non Integral - BHEL Scope) with supports & fixing arrangement with BOQ for GDE.	Secondary		
18	PE-V0-468-571-A918	Block logic diagram & Inter-Connection drawing of GDE.	Secondary		
19	PE-V0-468-571-A919	General Arrangement Drawings of (a) Vacuum Pump, (b) Vacuum Receiver, (c) Hydrocyclones (Primary & Secondary), (d) Belt Wash Pump, (e) Cake Wash Pump & (f) Vent Fan, along with cross sectional details, foundation plan and loading details.	Secondary		
20	PE-V0-468-571-A920	Cable Schedule of GDE.	Secondary		
21	PE-V0-468-571-A921	Electrical load List for GDE.	Secondary		
22	PE-V0-468-571-A922	Local Panel Control Circuit Diagram of GDE.	Secondary		
23	PE-V0-468-571-A923	General Arrangement Drawing & Data sheet of Motors for GDE.	Secondary		
24	PE-V0-468-571-A924	T-S & Performance curves of Vacuum Pump for GDE.	Secondary		
25	PE-V0-468-571-A925	I/O List (Drives & Instruments) of GDE.	Secondary		
26	PE-V0-468-571-A926	Utility Consumption of GDE.	Secondary		
27	PE-V0-468-571-A927	Schedule for Lubrication and other Consumables.	Secondary		
28	PE-V0-468-571-A928	Painting Schedule of GDE	Secondary		
29	PE-V0-468-571-A929	Bill of Material (BOM) of complete GDE for Main Supply	Secondary		
30	PE-V0-468-571-A929	Mandatory Spare List & BBU of GDE	Secondary		
31	PE-V0-468-571-A930	Platform Drawing of GDE with detailed BOQ	Secondary		
32	PE-V0-468-571-A931	Overall space and headroom requirement with details of handling during Erection, operation & maintenance of the equipments of GDE	Secondary		

	3x800 MW PATRATU TPS	SPECIFICATION No: PE-TS-434-571-A901	
	GYPSUM DEWATERING EQUIPMENT	SECTION : I	
	TECHNICAL SPECIFICATION	SUB-SECTION : D	
	MASTER DRAWING LIST WITH SCHEDULE OF	REV. 00	
	SUBMISSION	SHEET 4 OF 6	

33	PE-V0-468-571-A933	Erection & Commissioning Manual of GDE including- i. Installation and assembly procedure of complete GDE ii. Pre-Commissioning Check List of GDE	Secondary		
34	PE-V0-468-571-A934	Operation & Maintenance (O&M) Manual of GDE including Transportation and Storage Specification for GDE Components	Secondary		
35	PE-V0-468-571-A935	Schedule of Start-up & Commissioning Spares for GDE	Secondary		
36	PE-V0-468-571-A936	List of Special tools & Tackles for GDE	Secondary		
37	PE-V0-468-571-A938	Monthly Progress Report for GDE	Secondary		
38	PE-V0-468-571-A939	Packing List for complete GDE	Secondary		
39	PE-V0-468-571-A941	Performance Test Procedure of GDE	Secondary		

*Manufacturing Clearance to be given to the Vendor based on approval of 'Primary' Drawings.

*Secondary drawings are to be submitted within 2-3 weeks after approval of relevant primary drawings.

Notes:

1. The above drawing list is tentative and shall be finalized with the successful bidder after placement of order. While some of the drawings indicated above may not be applicable, some additional drawings may also be required based on scope of work.
2. Drawings shall be prepared in Auto-Cad/3D Modelling software latest edition, as applicable. Required no. of hard and soft copies (editable) of the drawings shall be furnished as per requirement specified elsewhere in the specification.
3. Only manual calculation with authentic supporting literature (e.g. extracts of hand Book/ standard/codes) shall be acceptable. All design calculations and drawings shall be in SI system only.
4. All the drawings and documents including general arrangement drawing, data sheet, calculation etc. to be furnished to the customer during detailed engineering stage shall include / indicate the following details for clarity w.r.t. Inspection, construction, erection and maintenance etc.:

	3x800 MW PATRATU TPS	SPECIFICATION No: PE-TS-434-571-A901	
	GYPSUM DEWATERING EQUIPMENT	SECTION : I	
	TECHNICAL SPECIFICATION	SUB-SECTION : D	
	MASTER DRAWING LIST WITH SCHEDULE OF	REV. 00	
	SUBMISSION	SHEET 5 OF 6	

- a) All drawings and documents shall indicate the list of all reference drawings including General Arrangement.
- b) All drawings shall include / show plan, elevation, side view, cross-section, skin section, blow-up view; all major self-manufactured and bought out items shall be labeled and included in BOQ / BOM in tabular form.
- c) Painting schedule shall also be made as a part of general arrangement drawing of each equipment / items indicating at least 3 trade names.
- d) All the drawings required to be furnished to customer during detailed engineering stage shall include technical parameters, details of paints and lubrication, hardness and BOQ / BOM in tabular form indicating all major components including bought out items and their quantity, material of construction indicating its applicable code / standard, weight, make etc.
- e) Drawings/ documents to be submitted for purchaser's review/ approval shall be under Revision A, B, C... etc. while drawings /documents to be submitted thereafter for customer's approval after purchaser's approval shall be under R-0, 1, 2, 3 etc.
- f) Drawings and documents not covered above but required to check safety of machines/ equipment/ system, shall be submitted during detailed engineering stage without any commercial implication.
- g) All drawings shall include "B.O.M" and indicate quantity, material of construction, make along with IS/BS No., Technical parameters, dimensions, hardness, machining symbol and tolerance, requirement of radiography and hydraulic tests, painting details, elevation, side view, plan, skin section and blow-up view for clarity.
- h) All drawings shall be prepared as per BHEL's title block and shall bear BHEL's drawing No. Documents marked for submission to BHEL's Customer shall also bear BHEL's Customer's drawing No.
- i) Schedule of drawings submissions, comment incorporations & approval shall be as stipulated in the specifications. The successful bidder shall depute his design personnel to BHEL's/ Customer's/ Consultant's office for across the table resolution of issues and to get documents approved in the stipulated time.
- j) Bidder to follow the following the drawing submission schedule:

	3x800 MW PATRATU TPS	SPECIFICATION No: PE-TS-434-571-A901	
	GYPSUM DEWATERING EQUIPMENT	SECTION : I	
	TECHNICAL SPECIFICATION	SUB-SECTION : D	
	MASTER DRAWING LIST WITH SCHEDULE OF SUBMISSION	REV. 00	SHEET 6 OF 6

- k) 1st submission of drawings from date of LOI as per the submission schedule.
- l) Every revised submission incorporating comments – within 7 days.
- m) Bidder to submit revised drawings complete in all respects incorporating all comments. Any incomplete drawing submitted shall be treated as non-submission with delays attributable to bidder's account. For any clarification/ discussion required to complete the drawings, the bidder shall depute his personal to BHEL for across the table discussions/ finalizations/ submissions of drawings.

	3x800 MW PATRATU TPS	SPECIFICATION No: PE-TS-434-571-A901	
	GYPSUM DEWATERING EQUIPMENT TECHNICAL SPECIFICATION	SECTION : I	
		SUB-SECTION : D	
		REV. 00	
PACKING PROCEDURE	SHEET 1 OF 4		

SECTION-I
SUB-SECTION-D
ANNEXURE-VI
PACKING PROCEDURE

	3x800 MW PATRATU TPS	SPECIFICATION No: PE-TS-434-571-A901	
	GYPSUM DEWATERING EQUIPMENT TECHNICAL SPECIFICATION	SECTION : I	
		SUB-SECTION : D	
		REV. 00	
		SHEET 2 OF 4	
PACKING PROCEDURE			

1.0	PACKING AND FORWARDING
1.	<p>Proper packing to be ensured.</p> <p>Indigenous Supply: Gypsum Dewatering Equipment & its components shall be wrapped in polythene bags & packed in a strong rigid wooden crate. Rain water should not enter into the pump internals during storage in the outer yard of power plant.</p> <p>Imported Supply: All imported supply should be packed as per Sea worthy packing standards Annexure-VII of this sub-section. All imported items should have Sea worthy packing. Liberal packing materials and struts shall be provided to arrest rolling and to protect from transit damages.</p>
2.	<p>Equipment and process materials shall be packed and semi-knocked down, to the extent possible, to facilitate handling and storage and to protect bearings and other machine surfaces from oxidation. Each container, box, crate or bundle shall be reinforced with steel strapping in such a manner that breaking of one strap will not cause complete failure of packaging. The packing shall be of best standard to withstand rough handling and to provide suitable protection from tropical weather while in transit and while awaiting erection at the site.</p>
3.	<p>Equipment and materials in wooden cases or crates shall be properly cushioned to withstand the abuse of handling, transportation and storage. Packing shall include preservatives suitable to tropical conditions. All machine surfaces and bearings shall be coated with oxidation preventive compounds. All parts subject to damage when in contact with water shall be coated with suitable grease and wrapped in heavy asphalt or tar impregnated paper.</p>
4.	<p>The entire equipment / system has to be supplied in containers and it should be suitable for storing in the outer yard of the plant for a minimum period of 12 months. Crates and packing material used for shipping will become the property of owner.</p>
5.	<p>Packaging or shipping units shall be designed within the limitations of the unloading facilities of the receiving ports and the ship will be used. It shall be the bidder's responsibility to investigate these limitations and to provide suitable packaging and shipping to permit transportation to site.</p>
6.	<p>Packing (tare) shall be part of the equipment cost and shall not be subject to return. The packing should ensure integrity and cohesiveness of each delivery batch of equipment during transportation. In case of equipment assemblies and unit's delivery in the packing of glass, plastics or paper the specification of packing with the material and weight characteristics are to be indicated.</p>
7.	<p>Each package should have the following inscriptions and signs stenciled with an indelible ink legibly and clearly:</p> <ol style="list-style-type: none"> a. Destination b. Package Number c. Gross and Net Weight d. Dimensions e. Lifting places f. Handling marks and the following delivery marking

	3x800 MW PATRATU TPS	SPECIFICATION No: PE-TS-434-571-A901	
	GYPSUM DEWATERING EQUIPMENT TECHNICAL SPECIFICATION	SECTION : I	
		SUB-SECTION : D	
		REV. 00	
		SHEET 3 OF 4	
PACKING PROCEDURE			

8.	Each package or shipping units shall be clearly marked or stenciled on at least two sides with the DETAILED SHIPPING ADDRESS –TO BE PROVIDED LATER. In addition, each package or shipping unit shall have the symbol painted in red on at least two sides of the package, covering one fourth of the area of the side.
9.	Each part of the equipment which is to be shipped as a separate piece or smaller parts packed within the same case shall be legibly marked to show the unit of which it is part, and match marked to show its relative position in the unit, to facilitate assembly in the field. Unit marks and match marks shall be made with steel stamps and with paint.
10.	Each case shall contain a packing list showing the detailed contents of the package. When any technical documents are supplied together with the shipment of materials no single package shall contain more than one set of such documents. Shipping papers shall clearly indicate in which packages the technical documents are contained.
11.	The case number shall be written in the form of a fraction, the numerator of which is the serial number of the case and the denominator the total number of case in which a complete unit of equipment is packed.
12.	Wherever necessary besides usual inscriptions the cases shall bear special indication such as "Top", "Do not turn over", "Care", "Keep Dry" etc. as well as indication of the center of gravity (with red vertical lines) and places for attaching slings (with chain marks).
13.	Marking for Safe handling: To ensure safe handling, packing case shall be marked to show the following: <ul style="list-style-type: none"> a. Upright position b. Sling position and center of Gravity position c. Storage category d. Fragile components (to be marked properly with a clear warning for safe handling)
14.	Each crate or package is to contain a packing list in a waterproof envelope. All items are to be clearly marked for easy identification against the packing List. All cases, packages etc. are to be clearly marked on the outside to indicate the total weight where the weight is bearing and the correct position of the slings are to bear an identification mark relating them to the appropriate shipping documents. All stencil marks on the outside of cases are either to be made in waterproof material or protected by shellac or varnish to prevent obliteration in transit.
15.	The packing slip shall contain the following information: - Customer name, Name of the equipment, Purchase Order number with Date, Address of the delivery site, Name and Address of the Sender, Serial Number of pump & accessories, BHEL item Code, Gross Weight and Net weight of Supplied items.
16.	Prior to transport from manufacturer's work to destination, components of the unit shall be completely cleaned to remove any foreign particles. Flange faces and other machined surfaces shall be protected by an easily removable rust preventive coating followed by suitable wrapping.
17.	All necessary painting, corrosion protection & preservation measures shall be taken as specified in painting schedule. Supplier shall consider the coastal environment zone which is defined as "very severe" during final finishing/shipping.
18.	Successful bidder shall furnish the detail packing /shipment box details with information like packing box size, type of packing, weight of each consignment, sequence no. of dispatch, no. of consignment for each deliverable item against each billing break up units/

	3x800 MW PATRATU TPS	SPECIFICATION No: PE-TS-434-571-A901	
	GYPSUM DEWATERING EQUIPMENT TECHNICAL SPECIFICATION	SECTION : I	
		SUB-SECTION : D	
		REV. 00	
PACKING PROCEDURE	SHEET 4 OF 4		

	<p>billable blocks. Without these details the BBU shall not be approved during detail engineering.</p> <p>Also, complete billing break-up with above mentioned details shall be submitted to Purchaser within 10 days of placement of the LOI.</p>
19.	All items/equipment shall be dispatched in properly packed condition (i.e. no item shall be dispatched in loose condition such that it becomes difficult to store/identify its location at site at a later stage).
20.	Cases which cannot be marked as above shall have metal tags with the necessary markings on them. The metal tags shall be securely attached to the packages with strong steel binding wire. Each piece, Skid, Case or package shipped separately shall be labelled or tagged properly.

BIDDER TO REFER SUB-SECTION C2-A FOR CUSTOMER SPECIFICATION IN THIS REGARD.

SPECIFICATION No: PE-TS-434-571-A901

SECTION : I

SUB-SECTION : D

REV. 00

Annexure VII- Seaworthy Packing Specification (1+52 Pages)

VOLUME IIB

TECHNICAL SPECIFICATION FOR SEAWORTHY PACKING FOR EXPORT JOBS

SPECIFICATION NO. PE-TS-888-100-A001



**BHARAT HEAVY ELECTRICALS LIMITED
POWER SECTOR
PROJECT ENGINEERING MANAGEMENT
NEW DELHI, INDIA**

	TITLE	SPECIFICATION NO. PE-TS-888-100-A001	
	TECHNICAL SPECIFICATION FOR SEAWORTHY PACKING FOR EXPORT JOBS	VOLUME II B	
		SECTION D	
		REV. NO. 0	DATE 10/08/2010
		SHEET 1 OF 52	

1.0 Purpose

The purpose of this specification is to describe minimum packing requirements for the different items/equipment for all export Project and also to define marking and shipping requirements during transportation by ship, road and air for all export jobs.

2.0 SCOPE

For export jobs, sea worthy packing capable of performing all necessary functions like prevention of damage to the contents, sufficient to support frequent handling and lengthy period of outdoor storage in adverse weather conditions are required. Workmanship and materials used shall be of high standard meeting the technical requirements and in accordance with best commercial export packing practices. Vendor shall be responsible for sea worthy export packing, however it shall meet the minimum requirements specified herein. Equivalent or better packing methods may be deployed subject to approval of the BHEL/Purchaser. Vendor shall submit the packing procedure for its equivalent for purchaser's approval during detailed engineering.

The scope this specification is to define VENDOR's responsibilities in terms of:

- Preservation of the GOODS/items/equipments before packing.
- Packing of the GOODS for road, rail, sea and/or air transportation to desired destination i.e. project site
- Making cases/crates
- Chemical Treatment/Fumigation before packing to prevent fungus, damage due to termite, borer, rats, etc.
- Marking of cases/crates.
- Other Services required.

3.0 Application

This specification is applicable to all the goods to be transported to project site and requires to be in transit for longer duration. *However, for "Misc cable erection items", "Fire sealing system" & "Exothermic welding material", the packing requirements shall be as per the procurement specification.*

4.0 Definitions

- "BHEL" : Main EPC vendor
- "OWNER" : Customer for a particular export project.
- "VENDOR" : Company(ies)/VENDOR(s) to whom the BHEL has placed Purchase Order for GOODS/ items/system/package.
- "GOODS": means all or part of the articles, material, equipment supplies including technical documentation, as described in the Purchase Order, to be supplied by VENDOR.
- "PACKER": Packaging Company to whom VENDOR intends to sub-contract the packing in case they do not have own packing capability/facilities .
- "FREIGHT FORWARDER" : Means the Company responsible for performing freight forwarding activities.

5. General Information

	TITLE	SPECIFICATION NO. PE-TS-888-100-A001	
	TECHNICAL SPECIFICATION FOR SEAWORTHY PACKING FOR EXPORT JOBS	VOLUME II B	
		SECTION D	
		REV. NO. 0	DATE 10/08/2010
		SHEET 2	OF 52

The following requirements are intended as minimum requirements, and compliance to these requirements in no way absolves or relieves VENDOR of any responsibility or obligation outlined in the Purchase Order. In all circumstances, the packing will be designed and constructed in order to support GOODS during transportation as well as to prevent the Goods from damage due to impact, extreme climatic conditions, sun and rain. It must be ensured that the delivery of the GOODS to the jobsite by sea, road or air, in good condition.

GOODS shall be export packed in compliance with the best-established practices for international projects, in accordance with the following instructions. In the event of any conflict between these specified requirement and the established practices, specification requirement shall govern.

Due to climatic conditions and the complex transport operation(s), it is essential that protection and packing is of the highest standard. Packing means to efficiently protect the GOODS during the total transport operation; from the moment they leave the factory until they are delivered to the jobsite, including handling operations (loading/unloading) and storage.

When VENDOR do not have packing capabilities/facilities of their own and therefore intends to sub-contract, VENDOR have to inform BHEL/Purchaser of the name and address of proposed PACKER(s) for approval.

6.0 Criteria for Selection of Packaging

Packages are to be made according to categories, described in articles 8.1 to 8.5, depending on the type of materials, their fragility and size.

These categories have been established for the protection of equipment and material during multi-mode transports, i.e.: combination of overland and sea transport; containerization, air transportation.

In a general manner, the GOODS have to be packed in such a way that crates, bundles, pallets can be stored into General Purpose containers, wherever possible.

If VENDOR has any doubt about the correct method of protection or packing, he should contact BHEL/Purchaser in order to mutually agree on the adequate type of packing to be used.

Materials can be classified in following categories

- Hazardous Material
- Non-Hazardous Material
-

Further to above categorisation, non-hazardous materials can be sub- categorised for selection of packing.

6.1 Hazardous Materials

Though handling of hazardous material may is not applicable in the scope of this specification. All hazardous material must be packed in adherence to the detailed requirement relating to packing, marking and labelling set out in the most recent report of the Board's Standard Advisory Committee on the Carriage of Dangerous Goods in Ships for sea freight, and the Restricted Articles Regulations, laid down by the International Air Transport Association for airfreight.

6.2 Non-Hazardous GOODS

The scope of this specification is to provide necessary guidelines for packing for power plant equipment, components, Pipings & Valves, Fittings, other structural items, electrical items, spare parts and erection materials. The procedure is defined in subsequent paragraphs in details in clause no. 8.0.

	TITLE	SPECIFICATION NO. PE-TS-888-100-A001	
	TECHNICAL SPECIFICATION FOR SEAWORTHY PACKING FOR EXPORT JOBS	VOLUME II B	
		SECTION D	
		REV. NO. 0	DATE 10/08/2010
		SHEET 3	OF 52

7.0 Marking Instructions & Despatch details, Storage Code

7.1 Marking Instructions & despatch details

Packages and crates will be marked with indelible black paint, resistant to seawater. Marking must be perfectly legible.

The shipping marks, which will be as per fig-13, shall be stencilled on two sides and one end in clear characters at least 5 centimetres high (where crate size permits, otherwise use optimum size for each package dimension).

When the GOODS are to be shipped in containers then marking may be stencilled on one end only. However, packages must be stowed in a manner that shows these marks.

Crates containing fragile articles must be packed with special precaution against risk of breakage and must be stencilled on all sides "FRAGILE - HANDLE WITH CARE". Where crates are not to be overturned, VENDOR must show on the crates, clear and readily visible identification as per fig-12, to ensure they are kept in the correct position.

Packages/equipment of 2,000 kg or more must be marked with slinging points on all sides, in addition to the centre of gravity marks.

Number packages consecutively i.e. 1 of 10, 2 of 10, etc. Do not duplicate package numbers. VENDOR is responsible for any loss or damage caused by incorrect marking.

All cases/crates shall also be marked with the appropriate international standard graphic symbols for handling as shown in Fig 12.

As a minimum, all cases/crates are to be marked clearly on all four sides with:

- "HANDLE WITH CARE"
- "RIGHT SIDE UP"
- "KEEP DRY"

In the case of packages with a single gross weight totalling 2,000 kg and/or a height of more than 1m, the centre of gravity shall be clearly marked with the symbol on two adjoining sides. For all items of equipment with an eccentric centre of gravity this symbol shall be marked at the bottom, side and top of the package.

The slinging and lashing points shall be marked with a chain symbol.

When packing in cases/crates, these packages shall also have metal corners at the slinging points. (Fig-11)

External front and rear sides of the boxes to be planed for writing instructions.

Dispatch details such as consigner/consignee address, contract and case details, country of origin, port of delivery, stacking instructions shall be written on one side of the boxes. An anodized aluminum plate as per details and specifications given in fig-13 shall be provided on one side of the boxes.

One copy of packing slip wrapped in polyethylene bag covered with aluminum packing slip holder to be nailed on the external surface of the box. One more copy of the packing slip wrapped in polyethylene bag is to be kept inside the box at the pertinent place.

	TITLE	SPECIFICATION NO. PE-TS-888-100-A001	
	TECHNICAL SPECIFICATION FOR SEAWORTHY PACKING FOR EXPORT JOBS	VOLUME II B	
		SECTION D	
		REV. NO. 0	DATE 10/08/2010
		SHEET 4	OF 52

7.2 Storage Code

The type of storage required is required to be specified, it will be shown on each packaging in **RED colour**.

- X Crates or packages to be stored outdoor without covers
- XX Crates or packages to be stored under tarpaulin
- XXX Crates or packages to be stored in covered or enclosed premises
- XXXX Crates or packages which must be stored in air-conditioned premises

8.0 GUIDELINES FOR PACKING GOODS

8.1 In the subsequent paragraphs details of different types of packings for different types of GOODS are defined. Vendor shall make packing details/procedure based on the guidelines and submit for approval.

8.1.1 Packing for Pipe, Fittings, Flanges and Valves, Structural Steel

Particular attention should be brought to pipe, fittings, flanges, valves and structural steel. Packing categories for piping and fittings will differ according to the diameter and wall thickness of these products. VENDOR shall comply with the following established practice.

IMPORTANT NOTE:

Depending on the project schedule and availability of ocean vessels, the piping and structural steel may be shipped in containers. In this event, VENDOR has to arrange the packages in such a way it allows the stuffing into Open Top in gauge containers.

8.1.2 Pipe

Where practicable, pipe lengths shall be limited to 11.8 meters.

All pipes 2" included and below shall be packed in crates. All pipes to be capped and ends sealed with waterproof tape.

Pipes over 2" up to 6", shall be bundled and banded in bundles of uniform length. Bundling is carried out with U-IRON or traversal planks, joined with threaded connecting rods with locknuts. Quantities and strapping positions depend on the lengths, with a 120 cm spacing to prevent distortion. Bundle weight shall not exceed 2,000 kg. All pipes are to be capped and ends sealed with waterproof tape (tape is not necessary if end caps are of the pre-shrunk or self-sealing type).

Pipes larger than 6" shall be shipped as single lengths with the ends capped. End caps are to be of the recessed type to enable the use of soft faced hooks, but still completely sealing the end and also protecting the weld.

All stainless steel piping must be packed separately in wooden crates. Any banding of bundles is to be with the same material.

8.1.3 Pipe Fittings, Flanges and Valves

All pipe fittings, flanges and valves up to 6", are to be packed in cases/crates. For items over 6", these may be fixed securely to a pallet base and enclosed in a crate, for protection. Where valves have actuators attached, rigidity must be ensured for the valve and actuator. The vulnerable parts of the actuator are to be completely protected within a wooden crate.

All stainless steel fittings, flanges and valves of all sizes, must be packed separately in wooden crates. Any strapping is to be with the same material.

8.1.4 Structural Steel

	TITLE	SPECIFICATION NO. PE-TS-888-100-A001	
	TECHNICAL SPECIFICATION FOR SEAWORTHY PACKING FOR EXPORT JOBS	VOLUME II B	
		SECTION D	
		REV. NO. 0	DATE 10/08/2010
		SHEET 5 OF 52	

Structural Steel, reinforcing rods, bars, etc., should be packed in bundles of uniform length. Refer to articles 8.1.2, for strapping requirements. Bundle weight not normally to exceed 2,000 kg. Fabricated structures and structural steelwork, etc, should be bundled and packed using wooden beams and long bolting to secure the load.

8.2 Bundling – Packing Category I

8.2.1 Type of Equipment

Equipment which is not subject to damage by corrosion or mechanical effect, i.e. pipes, piping, structural steel.

Packing category I

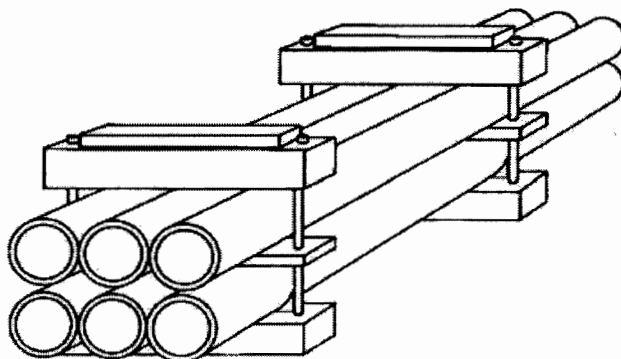

Bundling by U-shaped iron – packing category I A

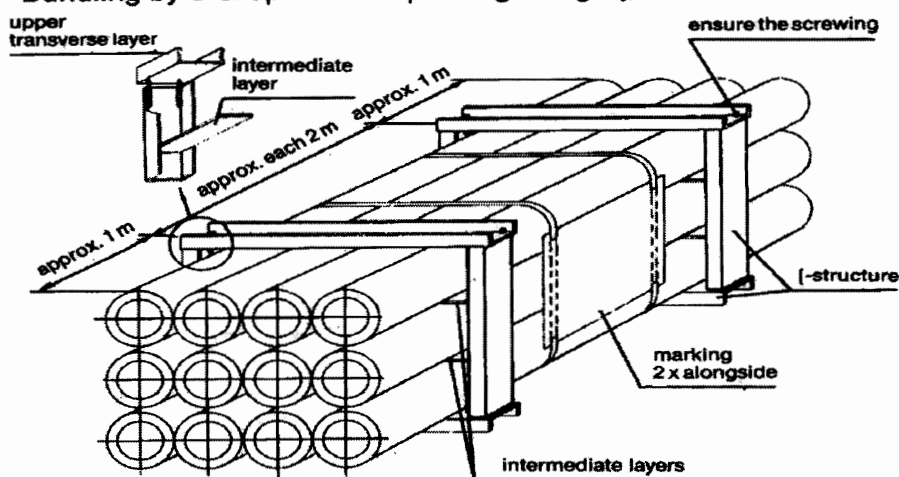

8.2.2 Type of Construction

	TITLE	SPECIFICATION NO. PE-TS-888-100-A001	
	TECHNICAL SPECIFICATION FOR SEAWORTHY PACKING FOR EXPORT JOBS	VOLUME II B	
		SECTION D	
		REV. NO. 0	DATE 10/08/2010
		SHEET 6	OF 52

- Bundling has to be effected
- By squared timber and threaded rods.
- With an intermediate layer (threaded on tightening bolts) according to the weight of the package.
- Wedge-shaped timbers must be added at the outer points of lower layer.
- Between the bolts a spacer must be nailed.
- The bolts must be secured (e.g. by locking nut).
- If single parts could protrude, an appropriate protection must be installed (flat iron or plates).
- Bundling with steel straps or PVC straps is not accepted.

8.3 Skids, Square Timber Constructions, Casings – Packing (Category II)

8.3.1 Type of Equipment

Voluminous apparatus, tanks and/or heavy pieces those are not vulnerable to mechanical or corrosive effects.

8.3.2 Type of Construction

- The construction skid can be made of wood or of metal.
- The fastening of the packages on the skid will be made by steel straps (flat iron) which have to be elastically lined, non-slip and securely bolted onto the skids.
- Flange openings have to be closed with gaskets and blind flanges or, if necessary, provided with cover.
- Skid constructions may not be less than the dimensions of the package in length or in width.
- Tanks and apparatus with their own support cradles must be supplied with an anti-slip lining.

PACKING CATEGORY-II

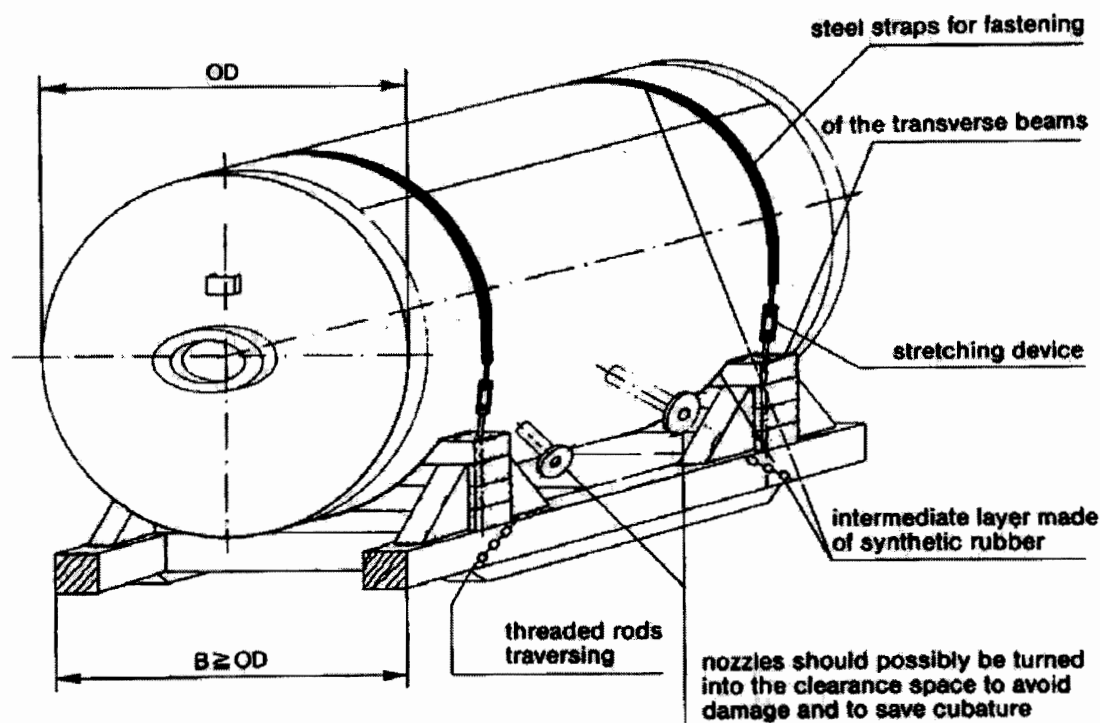

	TITLE	SPECIFICATION NO. PE-TS-888-100-A001	
	TECHNICAL SPECIFICATION FOR SEAWORTHY PACKING FOR EXPORT JOBS	VOLUME II B	
		SECTION D	
		REV. NO. 0	DATE 10/08/2010
		SHEET 7 OF 52	

8.4 Packing of GOODS in Wooden Crates/Cases/Boxes

The construction of wooden crate/cases/boxes shall be as per the details indicated in clause 9.0 & Fig 1 to 11. Details indicated in the sketches for different categories Packing crates/boxes are only for a typical equipment considered for illustration.

8.4.1 Packing Category III

8.4.1.1 Type of Equipment

Fabricated equipment, which cannot be transported on cradles; frame-works, prefabricated piping and fittings, mechanical and electrical assemblies. *This type of packing is recommended where many parts of the equipment/component/assembly are not protruding out.*

8.4.1.2 Type of Construction

The equipment must be safely fastened to the bottom with bolts, possibly by the runners or to be spread in such a manner that no protruding parts are possible. For parts, sensitive to rainwater and/or debris, a protection has to be made by a foil cap.

If it is possible that single part could protrude through the front/back side wall, they shall be closed completely. The marking of the package shall be done on plywood plates at the prescribed sides.

Packing Category III

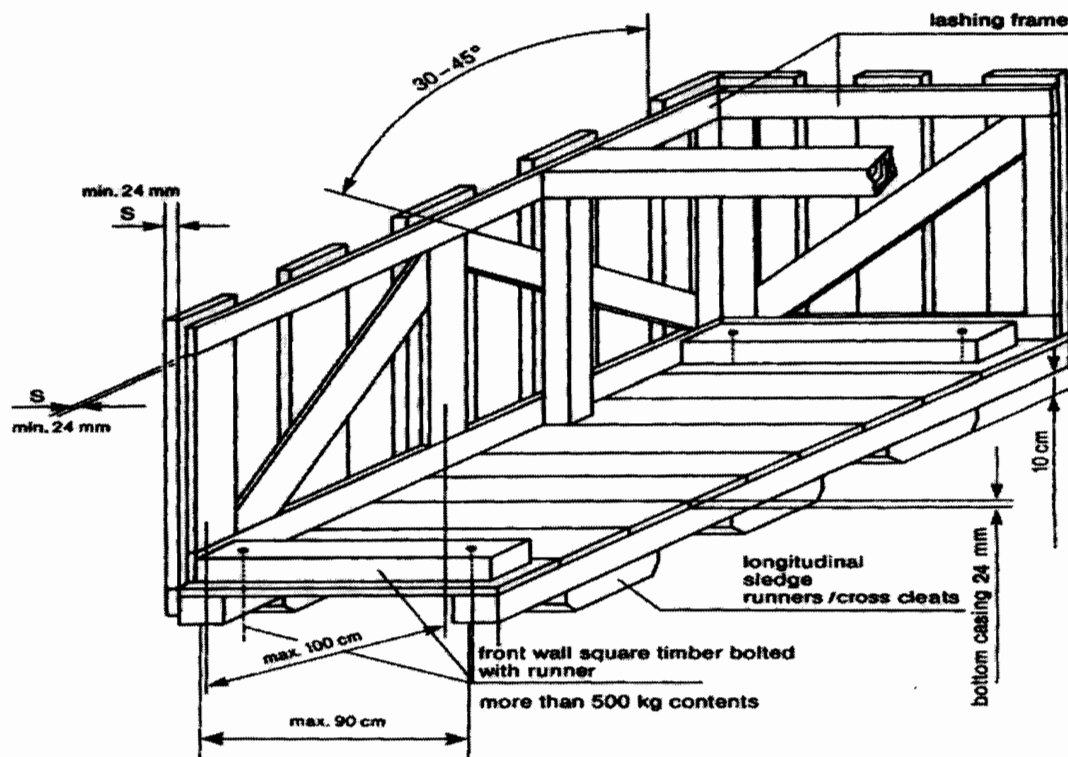

	TITLE	SPECIFICATION NO. PE-TS-888-100-A001	
	TECHNICAL SPECIFICATION FOR SEAWORTHY PACKING FOR EXPORT JOBS	VOLUME II B	
		SECTION D	
		REV. NO. 0	DATE 10/08/2010
		SHEET 8	OF 52

8.4.2 Cases with Lining – Packing Category IV

8.4.2.1 Type of Equipment

Recommended for equipment and mechanical parts Equipment sensitive to mechanical damage or parts and components that are particularly at risk of theft or loss; pumps, elbows, flanges, fittings, tools, erection materials, etc.

8.4.2.2 Type of Construction

The same type of construction as article 8.4.1.2, but with all sides completely boarded without space between the boards. Sides to be provided with waterproof lining; fabric-reinforced waterproof tar paper or polyethylene-foils resistant to ultraviolet rays can be used. Polyethylene-foil shall be fixed under the lid cover to avoid penetration of water. At weights of more than 500 kg the longitudinal runner must be bolted to the front all square timber. For ventilation inside the case, an opening in the waterproof lining must be placed between the diagonal battens and diagonal joists.

Packing Category IV

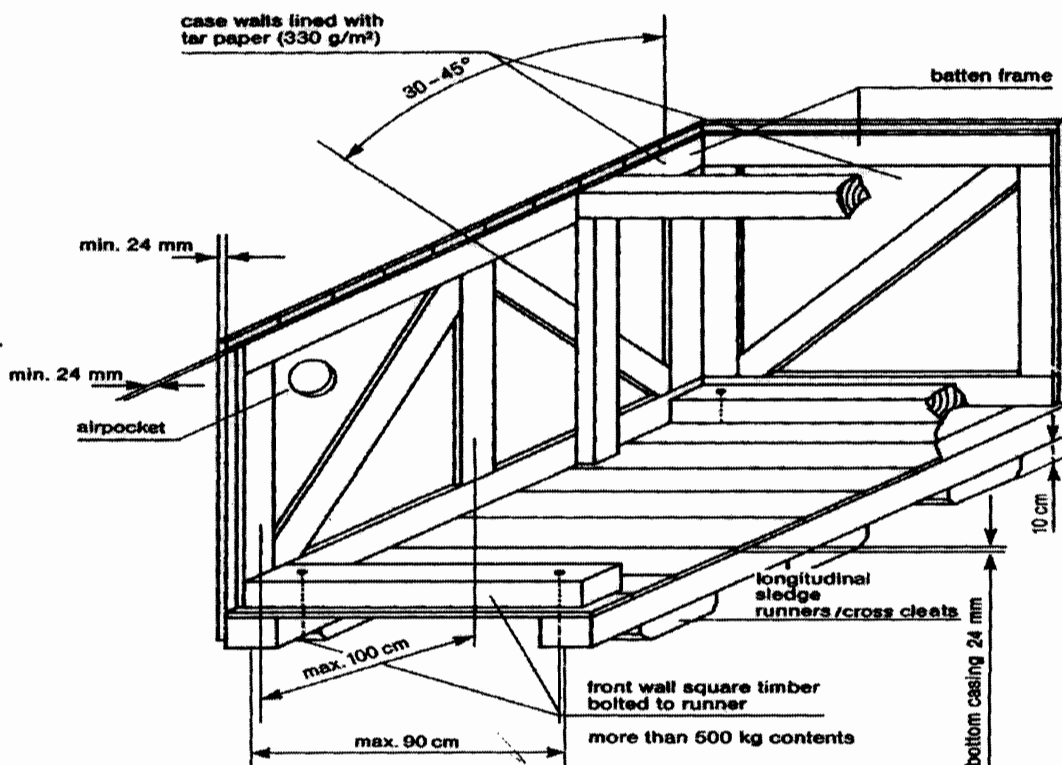

8.4.3 Cases with Alternative Surface Materials

8.4.3.1 Plywood Box – Packing Category IV A

	TITLE	SPECIFICATION NO. PE-TS-888-100-A001
	TECHNICAL SPECIFICATION FOR SEAWORTHY PACKING FOR EXPORT JOBS	VOLUME II B
		SECTION D
		REV. NO. 0 DATE 10/08/2010
		SHEET 9 OF 52

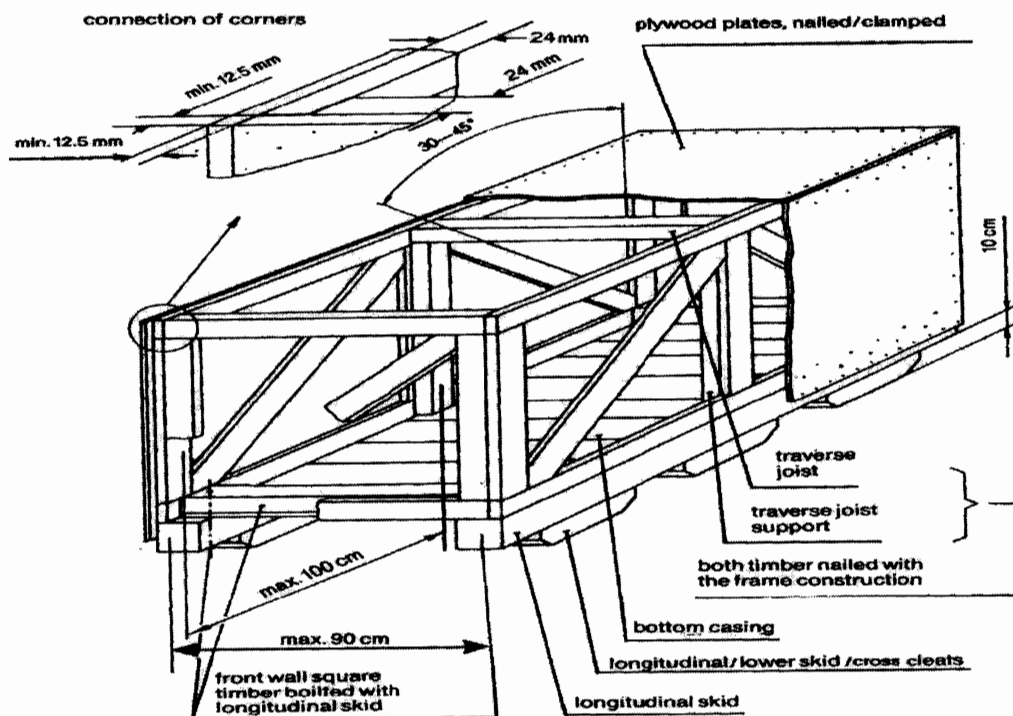

Case constructed of 5 layers of watertight, glued plywood with a total thickness of 12.5 mm. The frame must be constructed from minimum 24 mm timber or as per guide lines given above against clause 8.0, Fig 1 to 11 and must be suitable for the weight and nature of the parts to be packed. Planed square timber must be bolted with longitudinal skid and covered with diagonal joists. If applicable, construction of the cover and sides is to include diagonal bracing. Covers consisting of several layers of plywood are to be sealed with durable elastic putty or additional water-resistant sheets to be fixed.

8.4.4 Case with Barrier Material – Polyethylene Foil – Packing Category V

8.4.4.1 Type of Equipment

Sensitive equipment, simple electrical equipment, insulation materials, fire-resistant materials, with non-corrosion- guarantee for a period up to twelve (12) months.

8.4.4.2 Type of Construction

Preservation by welding in polyethylene-foil with addition of desiccants and if necessary, application of non-corrosive contact agents, otherwise, type of construction as indicated in article 8.4.2.2.

Additional marking:

- Case with desiccants.

8.4.5 Case with Barrier Material – Aluminium Compound Foil – Packing Category VI

8.4.5.1 Type of Equipment

	TITLE	SPECIFICATION NO. PE-TS-888-100-A001	
	TECHNICAL SPECIFICATION FOR SEAWORTHY PACKING FOR EXPORT JOBS	VOLUME II B	
		SECTION D	
		REV. NO. 0	DATE 10/08/2010
		SHEET 10	OF 52

Electrical equipment such as, switchboards, electric motors, sensitive equipment, with non-corrosion guarantee, for a period up to twelve (12) months.

8.4.5.2 Type of Construction

Type of construction as indicated in article 8.4.2.2. Preservation by sealing an aluminium compound foil, with the addition of desiccants. Humidity indicators, if required and installed in the barrier wrapping, shall allow easy control from the outside.

Additional marking:

- Case with desiccants.

Packing Category V/VI

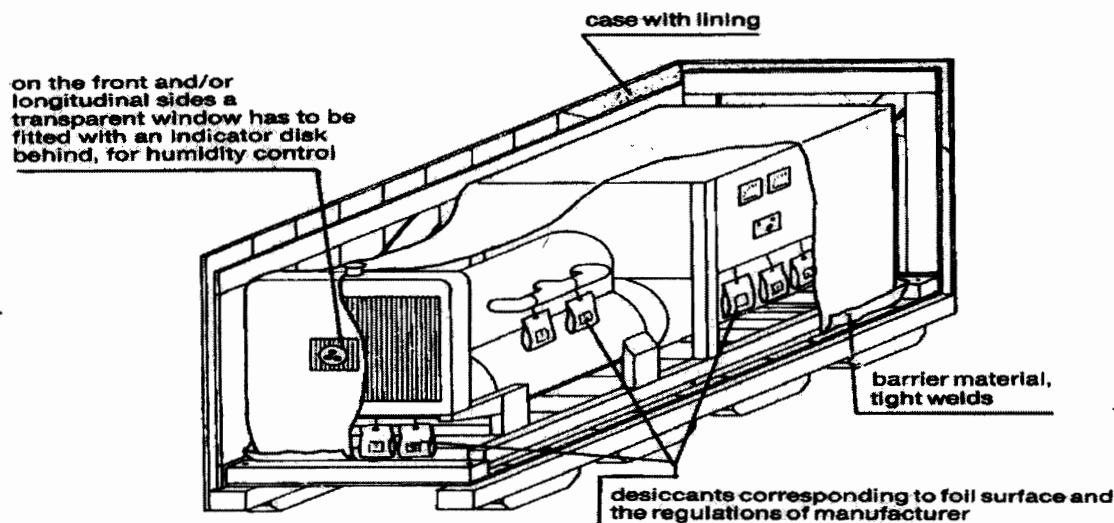

8.4.6 Double Case – Packing Category VII

8.4.6.1 Type of Equipment

GOODS which are of high sensitivity to shock, impact and vibration, for instance, special electrical equipment like computers, switchboards, laboratory instruments

8.4.6.2 Type of Construction

Case construction as indicated in article 8.4.2.2, with additional floating inner packing (case-in-case principle), padding corresponding to weight and sensitiveness. Preservation by sealing in aluminium compound foil with the addition of desiccants. The inner case has to be made of plywood or equivalent material with a thickness of 8-12 mm, depending on the weight of the GOODS to be packed. The inner buckles and/or frame borders have to be dimensioned so that the full stability of the inside case will be reached and no twisting is possible. The inner sides of the inside case will be lined with bituminous kraft paper on all sides (except bottom).

	TITLE	SPECIFICATION NO. PE-TS-888-100-A001	
	TECHNICAL SPECIFICATION FOR SEAWORTHY PACKING FOR EXPORT JOBS	VOLUME II B	
		SECTION D	
		REV. NO. 0	DATE 10/08/2010
		SHEET 11	OF 52

8.4.7 Cable Drum – Packing Category VIII

8.4.7.1 Type of Equipment

All type of cables, wires, ropes, hoses.

8.4.7.2 Type of Construction

For all type of cables refer clause no. 11.1. For other items (wires, ropes, hoses) new or practically new drums are to be used. Planking of the e drums by use of boards, thickness minimum 20 mm, with additional double steel strapping, nailed, and carefully preserved/protected cable ends prior to packing.

8.4.8 Hazardous Materials – Packing Category IX

8.4.8.1 Type of Equipment

Hazardous materials according to the law are explosives, compressed gases, liquefied gases dissolved under pressure or deeply refrigerated, flammable liquids, flammable solids: substances liable to spontaneous combustion; substances which, on contact with water, emit flammable gases, oxidizing substances, organic peroxides, poisonous (toxic) and infectious substances; radioactive materials, corrosives, miscellaneous dangerous goods.

8.4.8.2 Type of Construction

Hazardous materials shall always be packed and documented separately from any other material. Selection of packaging materials, execution of packing and marking as well as documentation shall always be in compliance with the applicable laws and regulations. Any certificates required for transportation or for authorities to be supplied before shipment of the GOODS.

8.4.9 Wooden Floor as a Transport Support – Packing Category X

8.4.9.1 Type of Equipment

Any materials to be stuffed in containers or on flat racks and that are not stowed on standard pallets or otherwise suitably packed

8.4.9.2 Type of Construction

- Longitudinal internal square timbers bolted to the front wall runners, longitudinal skid.
- Maximum distance between longitudinal runners 90 cm (middle to middle of the runner).
- Full boarding of the floor.
- Attaching of lifting lugs and/or iron ropes for lifting/pulling the units off the transport equipment.
- If applicable, preservation of the equipment by sealing in polyethylene-foil or aluminium compound foil and the addition of desiccants.

8.5 Air Transport Packing

8.5.1 General

Certain types of material may have to be shipped by air from their country of origin. This means of transport will be exceptional, and will be used only:

- For GOODS, which are highly sensitive to shock or vibrations, such as computers, electronic instruments, or those of small dimensions and weight.
- For GOODS urgently required at the module yard(s) and/or jobsite.

	TITLE	SPECIFICATION NO. PE-TS-888-100-A001		
	TECHNICAL SPECIFICATION FOR SEAWORTHY PACKING FOR EXPORT JOBS	VOLUME II B		
		SECTION D		
		REV. NO. 0	DATE 10/08/2010	
		SHEET 12	OF	52

8.5.2 Type of Packing

Depending on the goods to be packed, VENDOR may use one of the following types:

- A triple-corrugated cardboard container made with waterproofed glue and a barrier layer of polyethylene on the outsides to keep out humidity.
- Wooden/cardboard packing cases: the wood being used for the framework and base of the cases, waterproofed triple-corrugated cardboard being used for the sides and top. These cases are of the "Bell" type, and used for material of small or medium dimensions.
- For larger dimensions, plywood cases are acceptable. The timber characteristics, cross-sections and thickness will be systematically determined by the nature of the loads to be packed.

8.5.3 Dimensions

In order to optimize the existing transport facilities (passenger or cargo aircraft), the dimensions of:

- Triple-corrugated containers.
 - Wooden/cardboard packing cases.
 - Plywood cases.
- Are to be adapted to pallets used for air transportation.

9.0 Detailed specification for Wooden Crates/Boxes/Cases and other packing materials

9.1 Technical specification for wood

The wood shall be Fir, Chir, Silver Oak (Gravillea Robusta), chemically treated mango and Pinewood with moisture content not exceeding 50%. The wood shall have flexural and compressive strength, stiffness, shock absorption and nail retention properties. The wood shall be free from common defects such as warp, bone, twist, knot, cracks, splits, end splits, bend, visible sign of infection and any kind of decay caused by insects or fungus, etc. Surface cracks with maximum depth of 3mm are permissible. A continuous crack of any depth all along the length is not allowed.

9.2 Chemical Treatment of Wood:

The wood shall be chemically treated to provide protection against deterioration due to fungi and attack by termites, borers, marine organism and any other kind of infection. It shall be treated only after final processing like cutting, planning, joint grooving, etc.

9.3 TYPE, DESIGN & DIMENSION OF WOODEN PACKING CASES:

9.3.1 PACKING OF EQUIPMENTS

Various mechanical, electrical and C&I equipment e.g. Pumps, motors, equipment skids, heat exchangers, control panels, switch gears, transformers, etc. shall be wrapped in weather proof packing and then secured in wooden packing cases. The construction of wooden packing cases/crates shall be as per details given below and also given in figure 1 to 11.

9.3.1.1 Bottom Frame

	TITLE	SPECIFICATION NO. PE-TS-888-100-A001	
	TECHNICAL SPECIFICATION FOR SEAWORTHY PACKING FOR EXPORT JOBS	VOLUME II B	
		SECTION D	
		REV. NO. 0	DATE 10/08/2010
		SHEET 13	OF 52

The construction of bottom frame shall be as per Fig-2. The No. of slides/runners for bottom frames shall be selected depending upon the weight and overall dimensions of the load to be carried. The equipment shall be secured by fixing their base frame/plate with the help of bolt and nuts etc. to bottom frame of the wooden packing cases/crates. The equipment not provided with base frame/plate like cylindrical vessels, etc to be secured to the bottom frame of the wooden cases with "C" clamps fabricated from steel channels/ angle iron.

9.3.1.2 TOP FRAME

The construction of top frame shall be as per fig-3.

9.3.1.3 END PANELS

The dimension of the end and lateral panels shall be calculated according to overall dimensions of the items to be packed. Diagonal braces shall be used for packing cases having height exceeding 500mm. Details of bracings shall be as per fig 5 to 9.

9.3.1.4 Sling Plate

To facilitate lifting of cases, longitudinal under slide boards shall be fixed. To avoid damage to the box while lifting sling plates shall be provided. Refer fig-11.

9.3.1.5 Angle Iron Cleats

Angle iron cleats shall be used for strengthening the joints as indicated in fig-10

9.3.1.6 Other Requirements

- The thickness of planks for top, bottom, side and end panels shall be at least 25mm. Planks used for this purpose shall be joined with each other by tongue and groove joint. The groove dimension shall be such that tongue fits tightly into groove to make the joint.
- Runners/slides, traverse bars, etc shall be of single length i.e. without any joint. Planks for sheathing, diagonal bracing etc shall also be of single length up to 2400mm, proper jointing is permitted for planks for sheathing and diagonal bracings.
- Each equipment to be individually covered with double polyethylene petticoat. Sheet thickness of polythene sheet shall not be less than 0.175 mm (175 microns). The sealing shall be such so as not to allow moisture inside.
- The inner surface of 4 sides of shooks shall be nailed with bituminized water proof craft paper. Wherever 2 pieces of kraft paper are used, joint shall have an overlap of minimum 20 mm.
- All the inner sides of the box shall be nailed with bitumen coated HESSIAN POLYTHYLENE KRAFT PAPER. For top frame it shall project on all sides by 100mm and shall be nailed on sides. Wherever 2 pieces of kraft paper are used, joint shall have an overlap of minimum 20 mm.
- For delicate equipment like control panels and switchgears, lighting panels and lighting transformers, suitable cushioning material like rubberised coir (min. 50 mm thick and 100 mm wide) shall be provided on their bottom support and the gap between the panel and casing

	TITLE	SPECIFICATION NO. PE-TS-888-100-A001	
	TECHNICAL SPECIFICATION FOR SEAWORTHY PACKING FOR EXPORT JOBS	VOLUME II B	
		SECTION D	
		REV. NO. 0	DATE 10/08/2010
		SHEET 14	OF 52

shall be filled with rubberized coir with distance between consecutive supports less than 500 mm (ref fig15). For other equipment suitable support from sides of the casing shall be provided.

- Switchgear cubicles, control panels and control desks shall be packed and shipped in separate convenient sections. The components e.g. circuit breakers relays and instruments etc. which are removed from panels for shipping purpose and shall be separately packed and shipped as per packing instructions in clause 10.4.
- Packing case for control panels and switchgear panels shall be finally covered with GI sheet of minimum thickness of 0.4mm.
- Packing cases shall be bound at edges by nailing MS clamps/brackets at sufficient intervals. Further heavier boxes shall be strapped with C clamps (ref fig-4) fabricated from steel channels/angles and lighter boxes shall be strapped with hoop iron strips.
- Silica gel is used for this purpose to protect contents over sufficiently long time from corrosion. Silica gel shall be indicating type confirming to IS-304 (1979) packed in cotton bags placed at different positions inside the packing for absorbing moisture and shall not come into directly contact with equipment/material inside the package. The quantity of silica gel shall be adequate for storage period of one year, however it shall not be less than 4 gm. per ltr. Volume of case subject to minimum 400 gm. Per case.

	TITLE	SPECIFICATION NO. PE-TS-888-100-A001	
	TECHNICAL SPECIFICATION FOR SEAWORTHY PACKING FOR EXPORT JOBS	VOLUME II B	
		SECTION D	
		REV. NO. 0	DATE 10/08/2010
		SHEET 15	OF 52

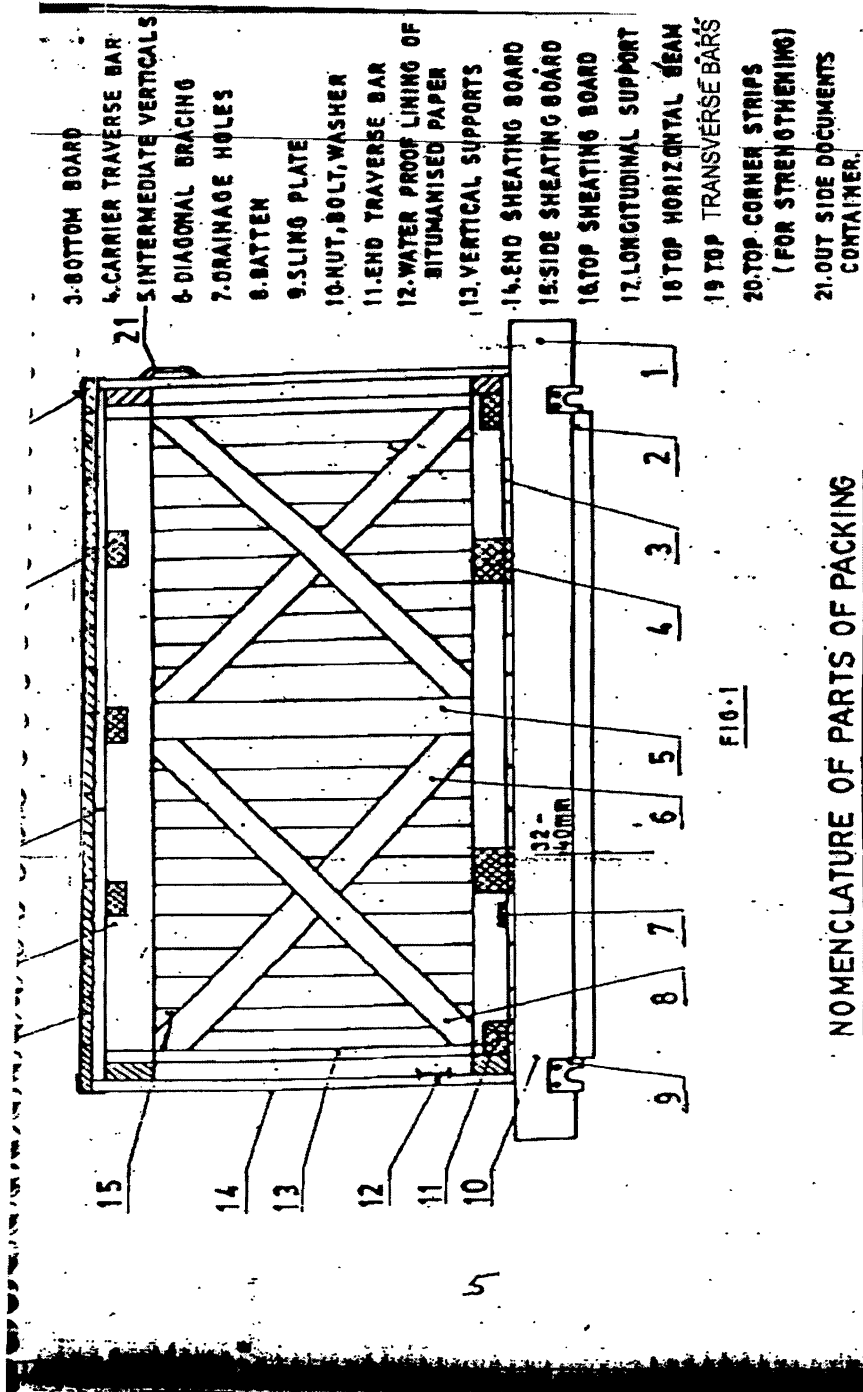

	TITLE	SPECIFICATION NO. PE-TS-888-100-A001	
	TECHNICAL SPECIFICATION FOR SEAWORTHY PACKING FOR EXPORT JOBS	VOLUME II B	
		SECTION D	
		REV. NO. 0	DATE 10/08/2010
		SHEET 16	OF 52

BOTTOM FRAME ARRANGEMENTS

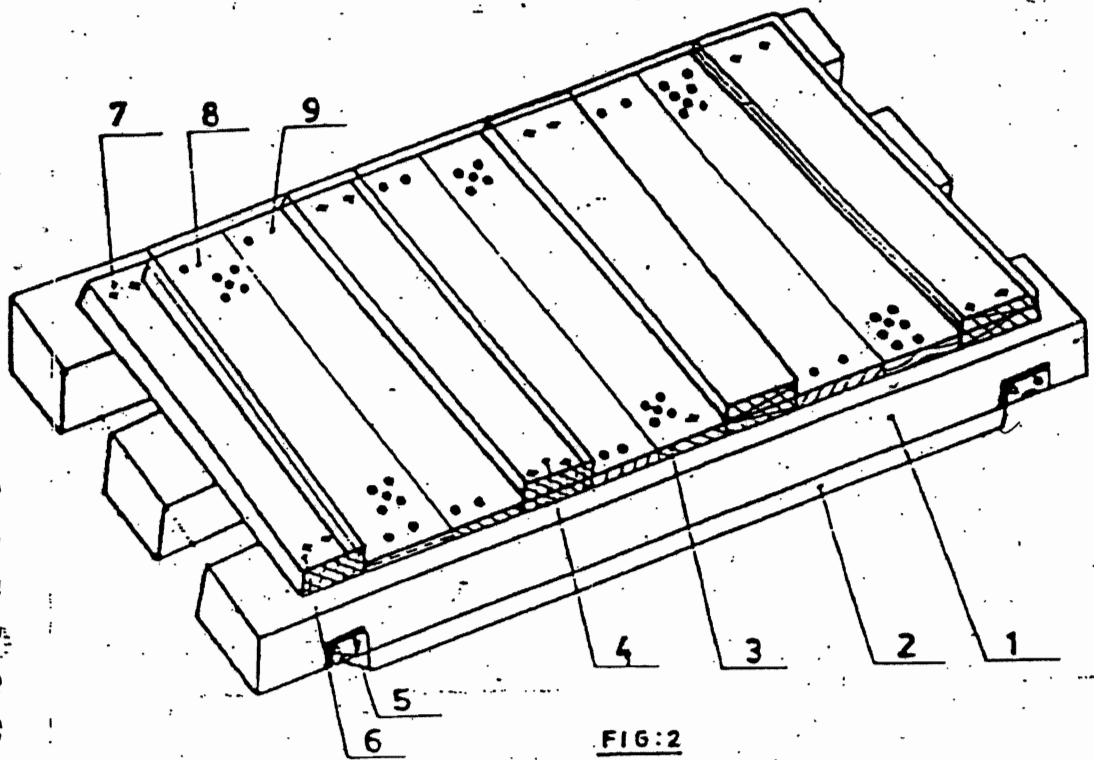

Nos. of slides: Minimum 2 Nos.
 For length more than 1800 mm or
 load more than 1000kg, nos. of
 slides shall be minimum 3 Nos.
 For dimensions of slides, refer Table 1
 Cross section of end traverse bar; 100 x 100 mm.
 (minimum)

- 1. SLIDE
- 2. UNDER SLIDE BOARD
- 3. BOTTOM BOARD
- 4. CARRIER TRAVERSE BAR
- 5. SLING PLATE
- 6. TRAVERSE BAR
- 7. BOLT, NUT & WASHER
- 8. DRAINAGE HOLES
- 9. NAILS

027

	TITLE	SPECIFICATION NO. PE-TS-888-100-A001
	TECHNICAL SPECIFICATION FOR SEAWORTHY PACKING FOR EXPORT JOBS	VOLUME II B
		SECTION D
		REV. NO. 0 DATE 10/08/2010
	SHEET 17 OF 52	

TOP FRAME ARRANGEMENT

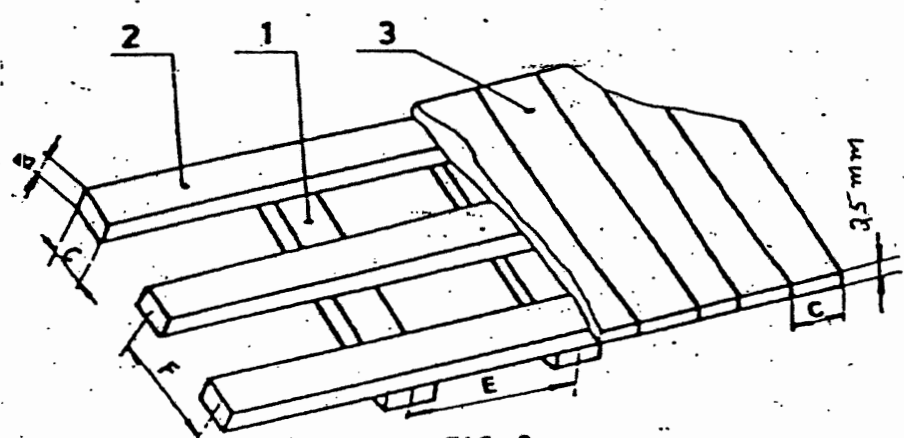
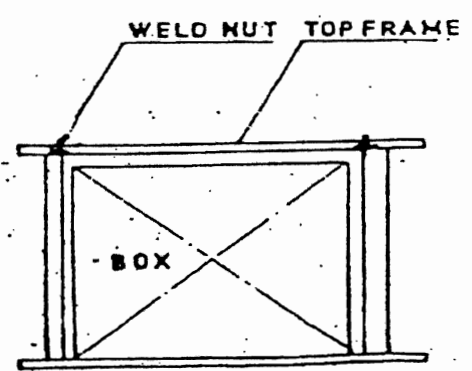
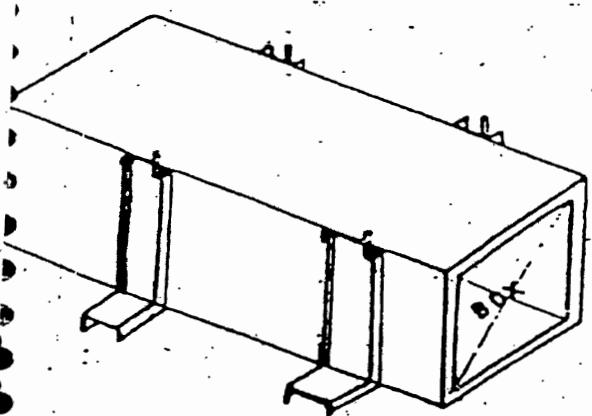



FIG-3

F : 700 to 1000 mm
 E : 500 to 900 mm
 C : 30x100 mm.

- 1 - Traverse Bars
- 2 - Horizontal Soans
- 3 - Top Board

ARRANGEMENT OF C-CLAMPS AROUND CASES



	TITLE	SPECIFICATION NO. PE-TS-888-100-A001
	TECHNICAL SPECIFICATION FOR SEAWORTHY PACKING FOR EXPORT JOBS	VOLUME II B
		SECTION D
		REV. NO. 0 DATE 10/08/2010
		SHEET 18 OF 52

ARRANGEMENT OF DIAGONAL BRACING AND HORIZONTAL SUPPORT

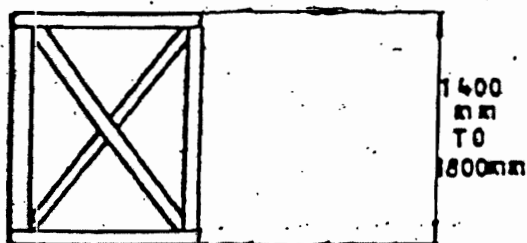

FIG: 6

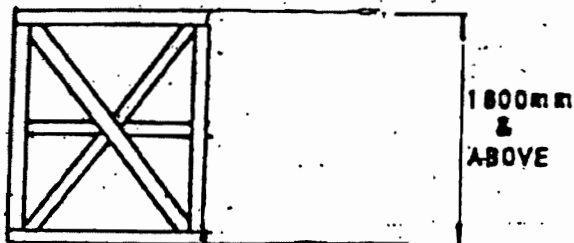

FIG: 8

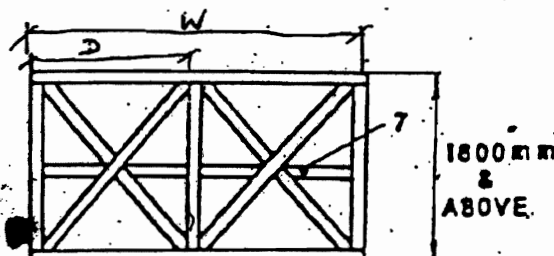

FIG: 7

7- Middle Horizontal Support

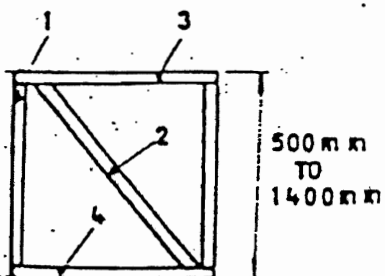

FIG: 5

1- Vertical Support

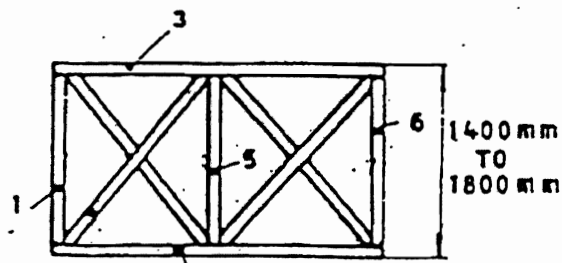

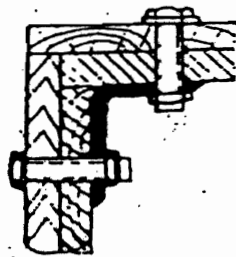
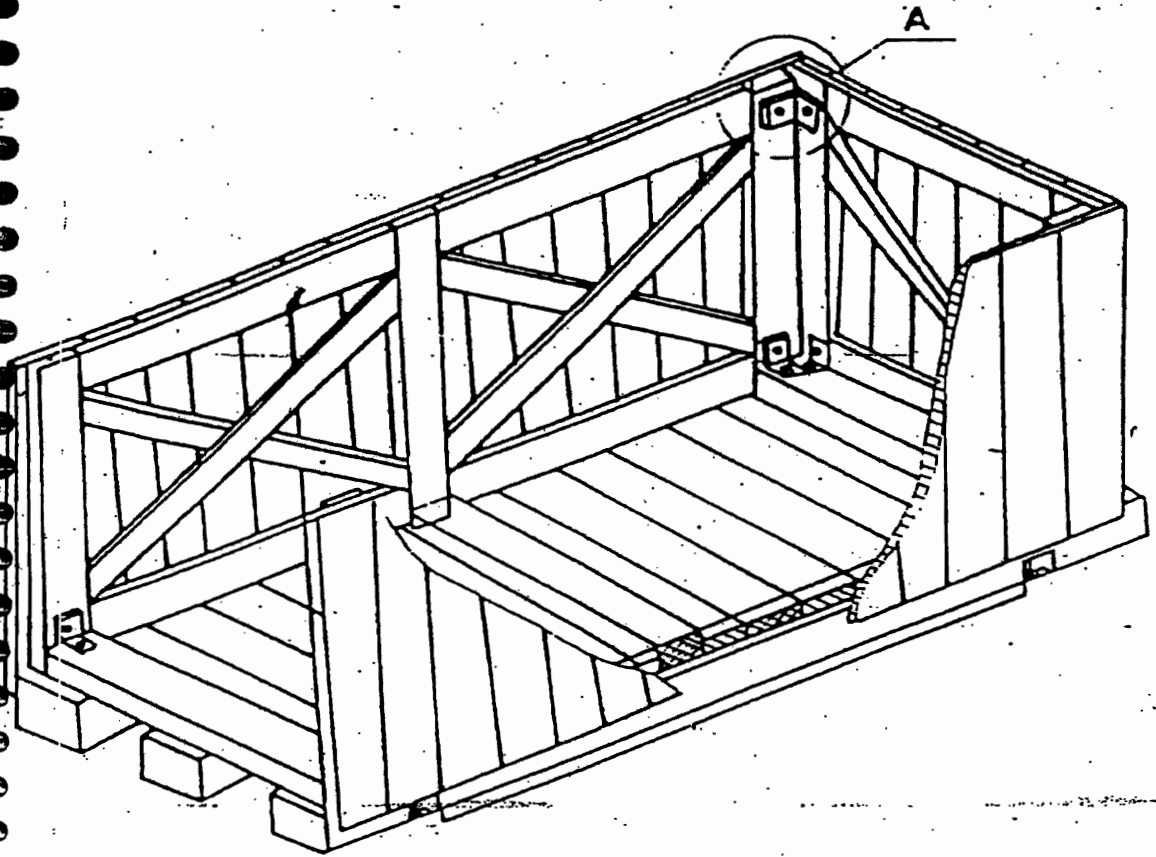

FIG: 7

1, 5, 6 - Vertical Support

	TITLE	SPECIFICATION NO. PE-TS-888-100-A001
	TECHNICAL SPECIFICATION FOR SEAWORTHY PACKING FOR EXPORT JOBS	VOLUME II B
		SECTION D
		REV. NO. 0 DATE 10/08/2010
		SHEET 19 OF 52

ARRANGEMENT OF PACKING CASE



DETAIL-A

HOLE DIAMETER
MUST CONFORM
TO BOLT DIA

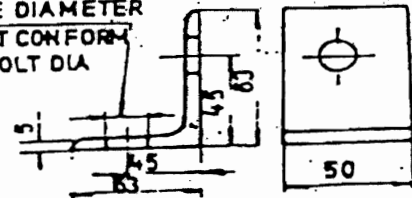

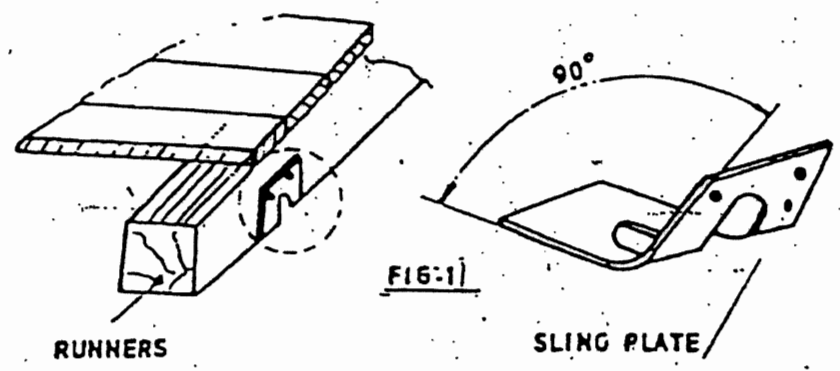

FIG:10

	TITLE	SPECIFICATION NO. PE-TS-888-100-A001
	TECHNICAL SPECIFICATION FOR SEAWORTHY PACKING FOR EXPORT JOBS	VOLUME II B
		SECTION D
		REV. NO. 0 DATE 10/08/2010
		SHEET 20 OF 52

ARRANGEMENT OF SLING & PLATE ON

CASES











	TITLE	SPECIFICATION NO. PE-TS-888-100-A001					
	TECHNICAL SPECIFICATION FOR SEAWORTHY PACKING FOR EXPORT JOBS	VOLUME II B					
		SECTION D					
		REV. NO. 0	DATE 10/08/2010				
		SHEET 22 OF 52					

Table-2

End and side panels	Width of the panel "W"	Distance between longitudinal support (Dimension "D")						
		600	800	1000	1200	1400	1600	1800
		Cross section b x c				Item 1 to 7		
Fig- 5 to Fig-9	600 to 1200	30	30	30	30	30	30	30
		X	X	X	X	X	X	X
	1201 to 1600	100	100	100	130	130	130	130
		X	X	X	X	X	X	X
	1601 to 2000	30	30	30	30	30	30	30
		X	X	X	X	X	X	X
	2001 to 3000	130	130	130	130	130	130	130
		X	X	X	X	X	X	X
	3001 to 4000	30	30	30	30	30	30	40
		X	X	X	X	X	X	X
	130	130	130	130	130	130	150	
	X	X	X	X	X	X	X	
	40	40	40	40	40	40	40	
	X	X	X	X	X	X	X	
	150	150	150	150	150	150	150	
	X	X	X	X	X	X	X	

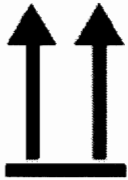
	TITLE	SPECIFICATION NO. PE-TS-888-100-A001	
	TECHNICAL SPECIFICATION FOR SEAWORTHY PACKING FOR EXPORT JOBS	VOLUME II B	
		SECTION D	
		REV. NO. 0	DATE 10/08/2010
		SHEET 23	OF 52

INDICATION MARKS ON CASES/BOXES/CRATES

Designation	Symbol	Explanation
Fragile, Handle with care		The symbol should be applied to easily broken cargoes. Cargoes marked with this symbol should be handled carefully and should never be tipped over or slung.
Use no hooks		Any other kind of point load should also be avoided with cargoes marked with this symbol. The symbol does not automatically prohibit the use of the plate hooks used for handling bagged cargo.
Top		The package must always be transported, handled and stored in such a way that the arrows always point upwards. Rolling, swinging, severe tipping or tumbling or other such handling must be avoided.
Keep away from heat (solar radiation)		Compliance with the symbol is best achieved if the cargo is kept under the coolest possible conditions. In any event, it must be kept away from additional sources of heat. It may be appropriate to enquire whether prevailing or anticipated temperatures may be harmful.
Protect from heat and radioactive sources		Stowage as for the preceding symbol. The cargo must additionally be protected from radioactivity.
Sling here		The symbol indicates merely where the cargo should be slung, but not the method of lifting. If the symbols are applied equidistant from the middle or center of gravity, the package will hang level if the slings are of identical length. If this is not the case, the slinging equipment must be shortened on one side.
Keep dry		Cargo bearing this symbol must be protected from excessive humidity and must accordingly be stored under cover. If particularly large or bulky packages cannot be stored in warehouses or sheds, they must be carefully covered with tarpaulins.

	TITLE	SPECIFICATION NO. PE-TS-888-100-A001	
	TECHNICAL SPECIFICATION FOR SEAWORTHY PACKING FOR EXPORT JOBS	VOLUME II B	
		SECTION D	
		REV. NO. 0	DATE 10/08/2010
		SHEET 24	OF 52

Center of gravity		This symbol is intended to provide a clear indication of the position of the center of gravity. To be meaningful, this symbol should only be used where the center of gravity is not central. The meaning is unambiguous if the symbol is applied onto two upright surfaces at right angles to each other.
No hand truck here		The absence of this symbol on packages amounts to permission to use a hand truck on them.
Stacking limitation		The maximum stacking load must be stated as "... kg max.". Since such marking is sensible only on packages with little loading capacity, cargo bearing this symbol should be stowed in the uppermost layer.
Clamp here		Stating that the package may be clamped at the indicated point is logically equivalent to a prohibition of clamping anywhere else.
Temperature limitations		According to regulations, the symbol should either be provided with the suffix "...°C" for a specific temperature or, in the case of a temperature range, with an upper ("...°C max.") and lower ("...°C min.") temperature limit. The corresponding temperatures or temperature limits should also be noted on the consignment note.
Do not use forklift truck here		This symbol should only be applied to the sides where the forklift truck cannot be used. Absence of the symbol on other sides of the package amounts to permission to use forklift trucks on these sides.
Electrostatic sensitive device		Contact with packages bearing this symbol should be avoided at low levels of relative humidity, especially if insulating footwear is being worn or the ground/floor is nonconductive. Low levels of relative humidity must in particular be expected on hot, dry summer days and very cold winter days.

	TITLE TECHNICAL SPECIFICATION FOR SEAWORTHY PACKING FOR EXPORT JOBS	SPECIFICATION NO. PE-TS-888-100-A001	
		VOLUME II B	
		SECTION D	
		REV. NO. 0	DATE 10/08/2010
SHEET 25 OF 52			

Do not destroy barrier		A barrier layer which is (virtually) impermeable to water vapor and contains desiccants for corrosion protection is located beneath the outer packaging. This protection will be ineffective if the barrier layer is damaged. Since the symbol has not yet been approved by the ISO, puncturing of the outer shell must in particular be avoided for any packages bearing the words "Packed with desiccants".
Tear off here		This symbol is intended only for the receiver.

FIG-12

	TITLE	SPECIFICATION NO. PE-TS-888-100-A001	
	TECHNICAL SPECIFICATION FOR SEAWORTHY PACKING FOR EXPORT JOBS	VOLUME II B	
		SECTION D	
		REV. NO. 0	DATE 10/08/2010
SHEET 26 OF 52			



		BHEL-PEM-DELHI-INDIA			
CONSIGNEE					
MATERIAL					
CUSTOMER REF.			MD. NO.		
DESPATCH ADVICE NOTE NO.			CASE NO.		
DIMENSIONS(MM) LXBXH			NET WT -KGS	GROSS WT -KGS	
SPECIAL INSTRUCTIONS	HANDLE WITH CARE -- KEEP DRY DO NOT DROP -- DO NOT TILT				

FIG-13: MARKING PLATE

	TITLE TECHNICAL SPECIFICATION FOR SEAWORTHY PACKING FOR EXPORT JOBS	SPECIFICATION NO. PE-TS-888-100-A001	
		VOLUME II B	
		SECTION D	
		REV. NO. 0	DATE 10/08/2010
SHEET 27 OF 52			

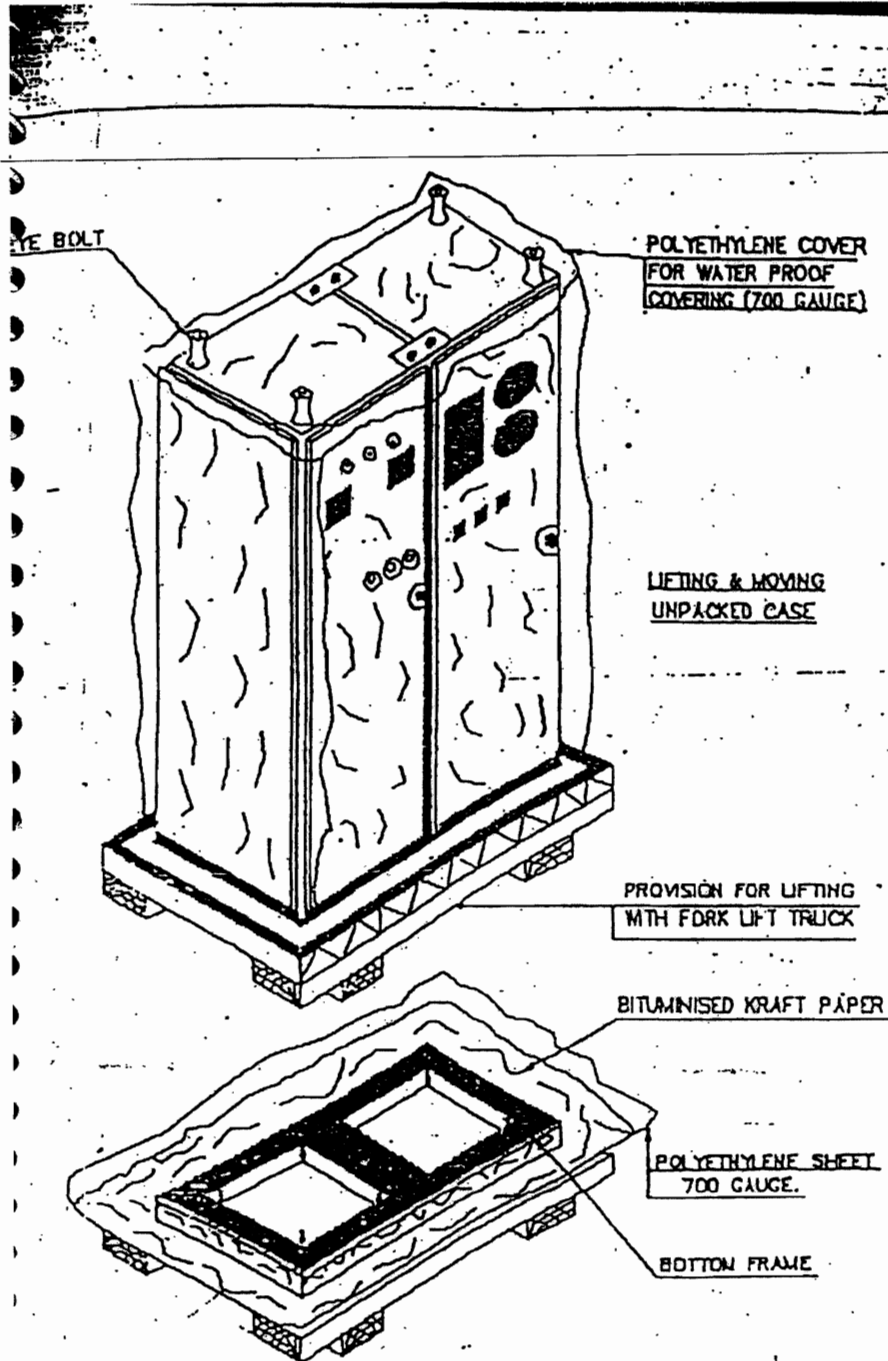



FIGURE-14

	TITLE	SPECIFICATION NO. PE-TS-888-100-A001		
	TECHNICAL SPECIFICATION FOR SEAWORTHY PACKING FOR EXPORT JOBS	VOLUME II B		
		SECTION D		
		REV. NO. 0	DATE 10/08/2010	
		SHEET 28	OF	52

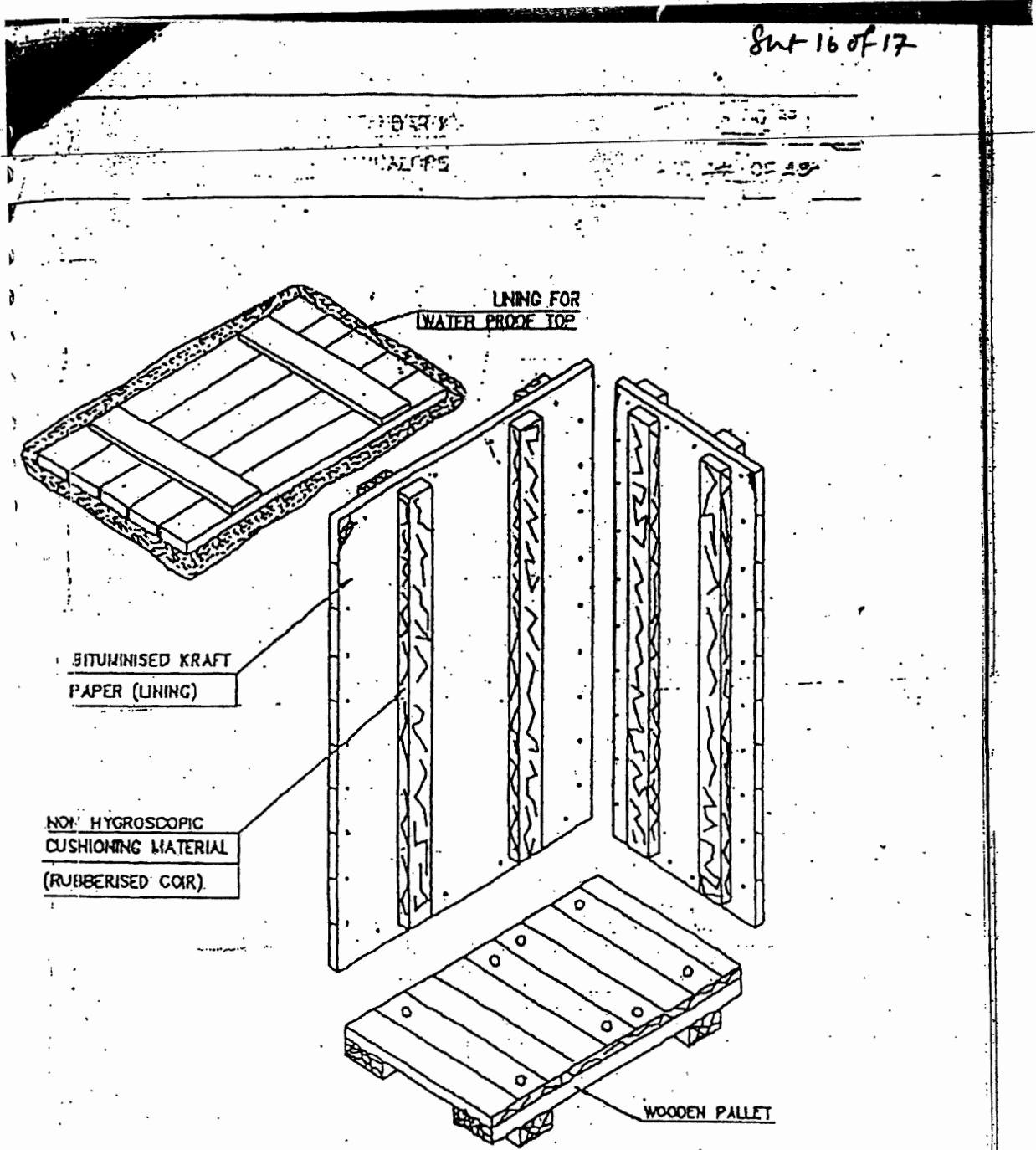



FIGURE-15

	TITLE	SPECIFICATION NO. PE-TS-888-100-A001	
	TECHNICAL SPECIFICATION FOR SEAWORTHY PACKING FOR EXPORT JOBS	VOLUME II B	
		SECTION D	
		REV. NO. 0	DATE 10/08/2010
		SHEET 29	OF 52

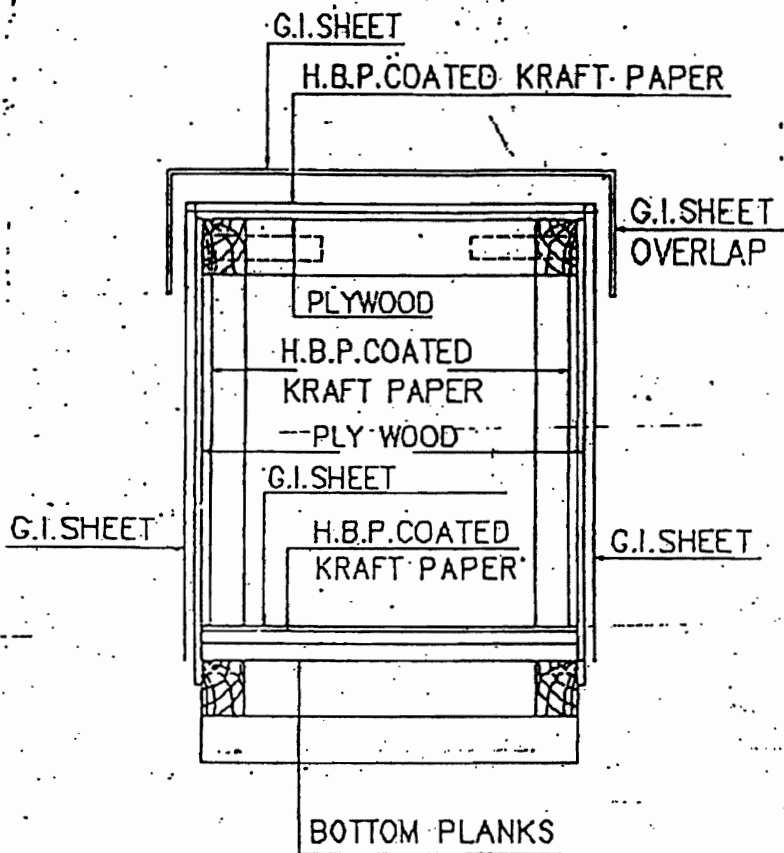



FIG-16 : CLOSED PACKING CASE WITH G.I.SHEET
SHOWING LAYERS OF PACKING MATERIALS.

	TITLE	SPECIFICATION NO. PE-TS-888-100-A001	
	TECHNICAL SPECIFICATION FOR SEAWORTHY PACKING FOR EXPORT JOBS	VOLUME II B	
		SECTION D	
		REV. NO. 0	DATE 10/08/2010
		SHEET 30	OF 52

10.0 TYPICAL PACKING DETAILS/PROCEDURE FOR MECHANICAL ITEMS

10.1 INSULATION MATERIAL (MINERAL WOOL MATTRESSES)

This specification covers the requirements of seaworthy packing and marking for bonded mineral (rock) wool mattresses having metallic hexagonal wire netting as facing on one or both sides.

10.1.1 TYPE OF CONSTRUCTION

Mattress shall be packed in Polythene (of 0.2 mm thickness) all around and sealed to prevent moisture absorption during transit and storage. Further it shall be wrapped with Bitumen coated Polythene bonded/lined Hessian and stitched and then packed in 5 ply DFC carton box.

Silica gel is used for this purpose to protect contents over sufficiently long time from corrosion. Silica gel shall be of indicating type conforming to IS:304-1979 packed in cotton bags placed at different positions inside the packing for absorbing moisture and shall not come into direct contact with the material inside the package. The quantity of silica gel shall be enough for storage period of one year. However, it shall not be less than 4 gms per litre volume of case subject to minimum of 400 gms per case.

Each mattress as well as the packages shall be serial numbered. Also, printed sheets indicating the nominal thickness, density and wire netting details (i.e. material and size) shall be placed below the wire netting.

Following details shall be legibly written on the packages. The details shall also be typed on a sheet of paper & kept in a sealed Polythene cover, inside the packages

- a) Project Name
- b) Purchase Order No.
- c) Sl. No. of package
- d) Size of mattress (Thickness x Length x Width)
- e) Density
- f) Wire netting material and size
- g) Weight of the package

10.2 INSULATION MATERIAL (ALUMINIUM COIL)

Heavy Gauge Aluminium Coil Packaging are done by Eye-to-Sky packaging or by Eye to eye packaging as per the proven practice being followed by manufacturer of Aluminium sheets.

10.2.1 Type of construction for Eye to Sky packaging

- a. Strapping of coil with polyester strap around circumference at one place.
- b. Putting paper I. D. Edge protector.
- c. Wrapping the coil with VCI stretch film after putting silica gel bags (4 nos.) Inside the coil.
- d. Wrapping the coil with HDPE film.
- e. Covering the coil including its build up & bore with masonite / particle board.
- f. Putting metallic I. D on coil.
- g. Putting O.D edge protector (paper) on coil.

	TITLE	SPECIFICATION NO. PE-TS-888-100-A001	
	TECHNICAL SPECIFICATION FOR SEAWORTHY PACKING FOR EXPORT JOBS	VOLUME II B	
		SECTION D	
		REV. NO. 0	DATE 10/08/2010
		SHEET 31	OF 52

- h. Putting circumferential polyester strap (3 nos.) & eye polyester strap (4 nos.).
- i. After placing the coil on coil tilter ply wood (10mm thick) of suitable size along with wooden pallet is to be put at the bottom side of the coil.
- j. Coil is to be tilted to eye-to-sky position.
- k. Final strapping with metallic strap to unit coil and skid at 2 places with top cover of plywood.
- l. Fixing the coil with wooden blocks at 4 corners.
- m. Labeling 2 nos.(one metallic & one adhesivetype) For specification, net wt. & gross wt.

10.2.2 Type of construction for Eye to Eye packaging

- a. Strapping of coil with polyester strap around circumference at one place.
 - b. Putting paper I. D. Edge protector.
 - c. Wrapping the coil with VCI stretch film after putting silica gel bags (4 nos.) Inside the coil.
 - d. Wrapping the coil with HDPE film.
 - e. Covering the coil including its build up & bore with masonite / particle board.
 - f. Putting metallic I. D on coil.
 - g. Putting O.D edge protector (paper) on coil.
 - h. Putting circumferential polyester strap (3 nos.) & eye polyester strap (4 nos.).
 - i. Placing of coil on wooden skid Coil is to be tilted to eye-to-sky position.
 - j. Final strapping of coil and skid at 2 places with steel strap. Fixing the coil with wooden blocks at 4 corners.
- Labeling 2 nos.(one metallic & one adhesive type) For specification net wt. & gross wt.

10.3 Packing Procedure for Online Tube Cleaning System and accessories

This procedure is applicable for the shipment of Onload Tube Cleaning System and accessories by sea.

10.3.1 Packing details:

- The Packing case shall be made of treated rubber wood. The design of the case shall be as per Annexure IIIA & IIIB.
- The Equipments shall be placed on the wooden base of the Packing case and fastened if required to arrest the movement of the same.
- Equipment shall be covered by Polythene sheet and inside wall surfaces of the wooden cases also shall be covered by polythene sheet.
- All Nozzles shall be closed with plywood dummies.
- All electrical components assembled or loose shall be covered with polythene sheets along with silica gel pack.
- Silica gel desiccants shall be kept inside each case in sufficient quantities in order to absorb the moisture.

	TITLE TECHNICAL SPECIFICATION FOR SEAWORTHY PACKING FOR EXPORT JOBS	SPECIFICATION NO. PE-TS-888-100-A001	
		VOLUME II B	
		SECTION D	
		REV. NO. 0	DATE 10/08/2010
		SHEET 32	OF 52

- Thermocol packing shall be made for glass items like Ball vessel sight glass, Vpiece sight glass & pressure gauge.
- Silica gel desiccants shall be kept inside of each case to absorb the moisture.
- A Packing list covered in a polythene envelope shall be fixed inside and outside of each packing case.
- Shipping marks and consignee address shall be painted on the outer surface of the case.
- All handling instruction required for the case like top, sling, rain, handle with care etc, shall be marked on the case as per the symbol attached.
- Machined surface will be applied with Anti rust oil and covered by polyurethane sheet to protect from external oxidation.
- All valves will be closed with dummies to protect the internals and placed in the wooden case which will covered by polyurethane sheet.

	TITLE	SPECIFICATION NO. PE-TS-888-100-A001	
	TECHNICAL SPECIFICATION FOR SEAWORTHY PACKING FOR EXPORT JOBS	VOLUME II B	
		SECTION D	
		REV. NO. 0	DATE 10/08/2010
		SHEET 33	OF 52

MODEL: FASTNERS TYPE (BASE, SIDE & TOP ATTACHED WITH BOLT, NUT & WASHER)

This Type of case to be used for following items:

1. BALL SEPERATOR
2. BALL COLECTOR SKID

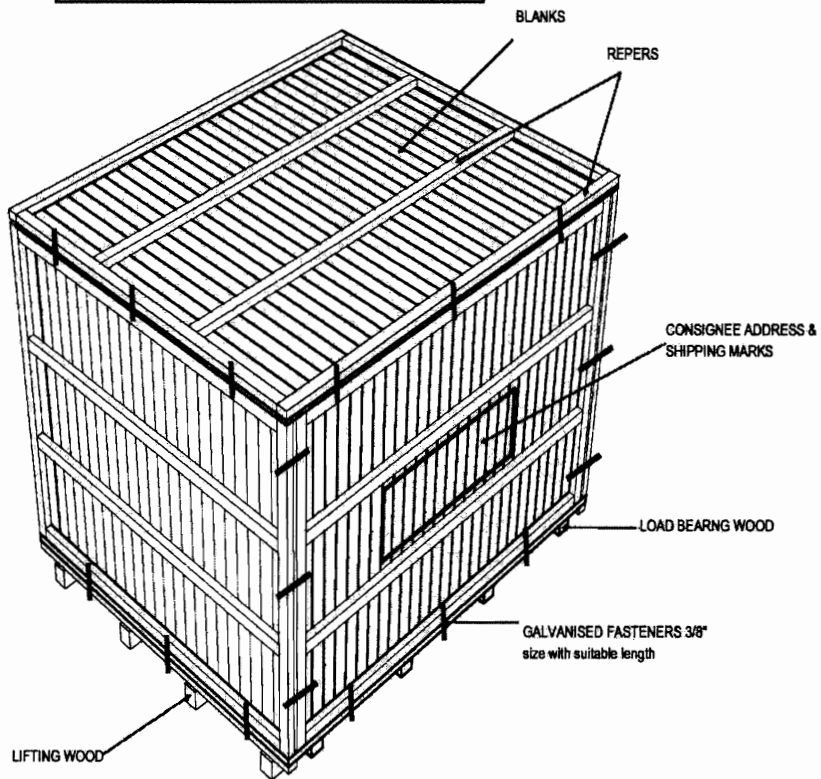

	TITLE TECHNICAL SPECIFICATION FOR SEAWORTHY PACKING FOR EXPORT JOBS	SPECIFICATION NO. PE-TS-888-100-A001	
		VOLUME II B	
		SECTION D	
		REV. NO. 0	DATE 10/08/2010
		SHEET 34	OF 52

BASE FRAME

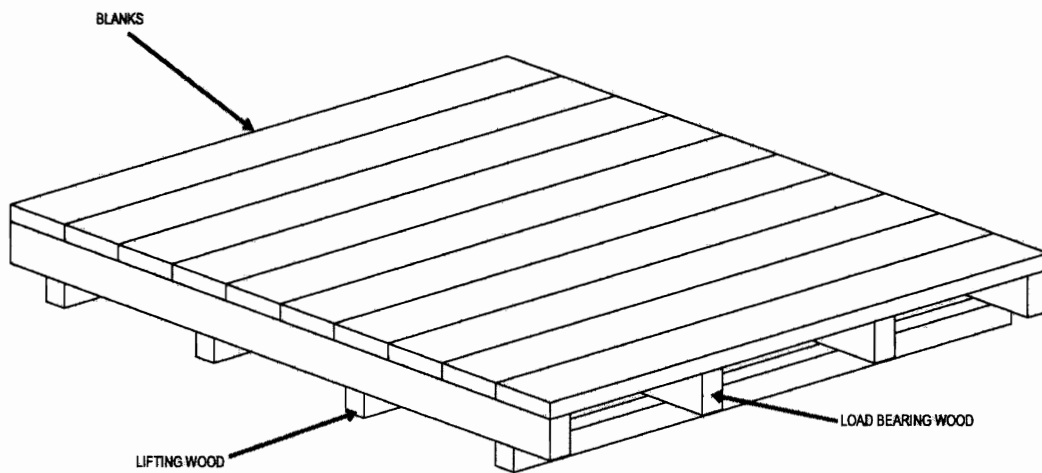

	TITLE	SPECIFICATION NO. PE-TS-888-100-A001	
	TECHNICAL SPECIFICATION FOR SEAWORTHY PACKING FOR EXPORT JOBS	VOLUME II B	
		SECTION D	
		REV. NO. 0	DATE 10/08/2010
		SHEET 35	OF 52

MODEL: FASTNERS TYPE - WITHOUT TOP

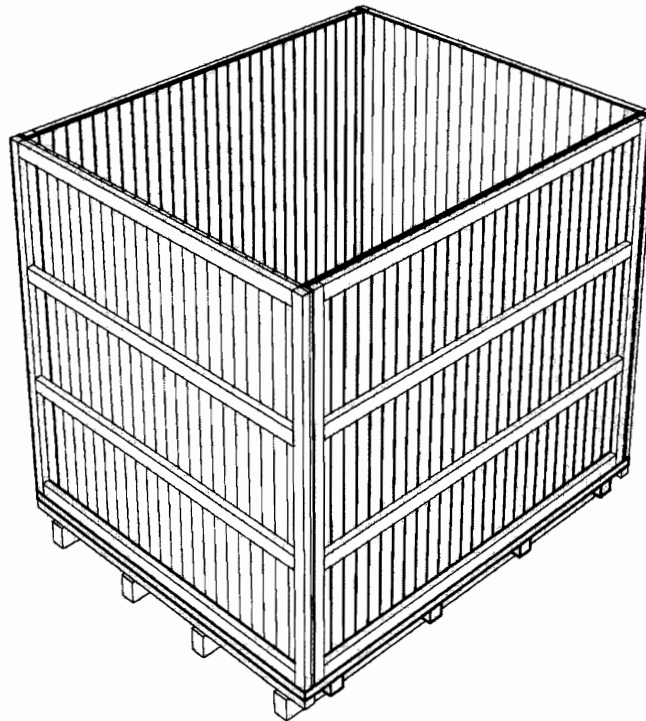

	TITLE	SPECIFICATION NO. PE-TS-888-100-A001	
	TECHNICAL SPECIFICATION FOR SEAWORTHY PACKING FOR EXPORT JOBS	VOLUME II B	
		SECTION D	
		REV. NO. 0	DATE 10/08/2010
		SHEET 36	OF 52

MODEL: NAILING TYPE
(FRAME & INSIDE REEPER NAILED)

- THIS TYPE OF CASE TO BE USED FOR THE FOLLOWING ITEMS:
- 1. PUMP SKID
 - 2. CONTROL PANEL
 - 3. LOOSE ITEMS, TOOLS & TACKLES
 - 4. DPMS, BRM
 - 5. SPARES
 - 6. CLEANING BALLS
 - 7. CABLES & ACCESSORIES

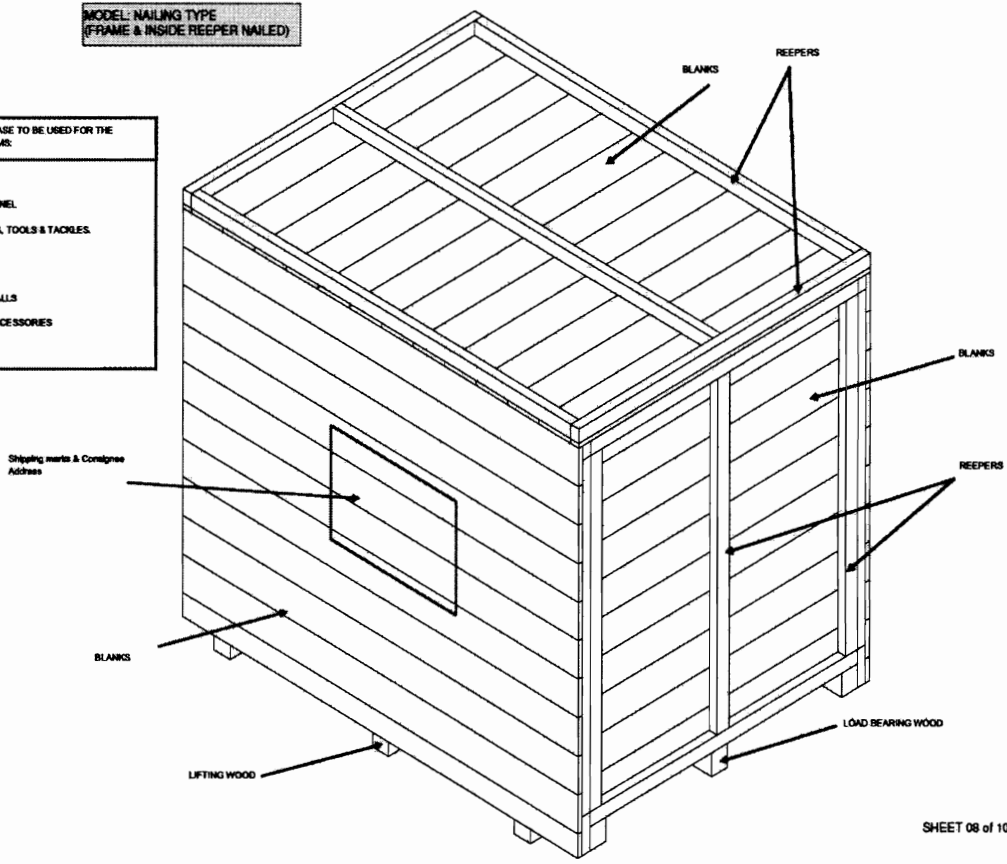

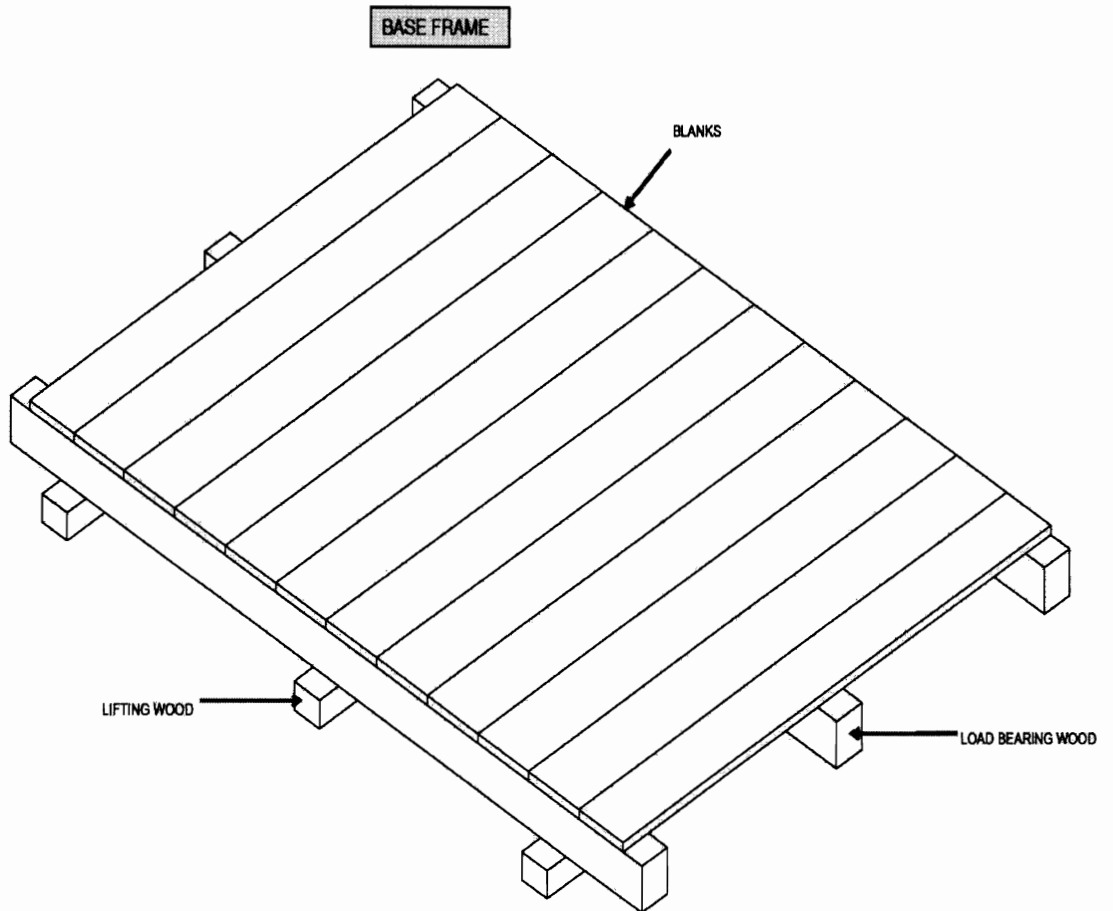

	TITLE	SPECIFICATION NO. PE-TS-888-100-A001	
	TECHNICAL SPECIFICATION FOR SEAWORTHY PACKING FOR EXPORT JOBS	VOLUME II B	
		SECTION D	
		REV. NO. 0	DATE 10/08/2010
		SHEET 37	OF 52

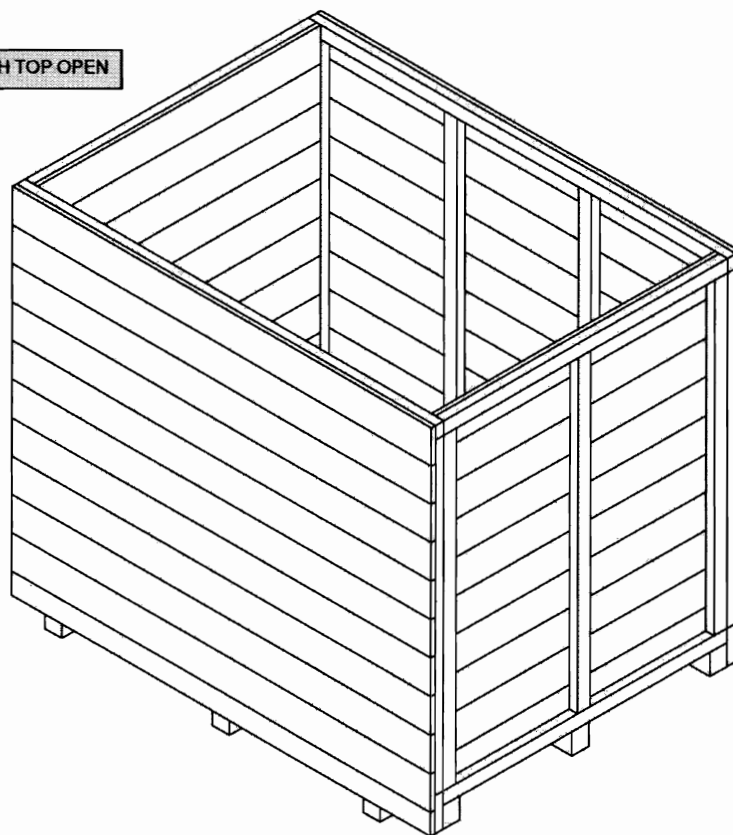

	TITLE TECHNICAL SPECIFICATION FOR SEAWORTHY PACKING FOR EXPORT JOBS	SPECIFICATION NO. PE-TS-888-100-A001	
		VOLUME II B	
		SECTION D	
		REV. NO. 0	DATE 10/08/2010
		SHEET 38	OF 52

NAILING TYPE MODEL WITH TOP OPEN



	TITLE	SPECIFICATION NO. PE-TS-888-100-A001	
	TECHNICAL SPECIFICATION FOR SEAWORTHY PACKING FOR EXPORT JOBS	VOLUME II B	
		SECTION D	
		REV. NO. 0	DATE 10/08/2010
		SHEET 39	OF 52

10.4 PACKING OF LOOSE ITEMS

Loose mechanical, electrical and C&I items e.g. valves, fittings, pressure/temperature gauges/switches, circuit breakers, relays etc shall be individually wrapped using polyethylene sheets/U foam/ thermocol sheets/air bubble sheets depending upon the items and then packed in wooden boxes. The left out spaces and top of the boxes shall be filled with rubberized coir to get proper cushioning effect, Special attention shall be paid to relays, instruments etc for arresting the movements of their operating mechanism during transportation.

The construction of wooden packing cases shall be as per clause 9.3.1 retaining its all features concerning strength of the box. The construction of wooden packing case for electrical and C&I items shall be as per fig-16.

Inner surface of 6 sides of the box shall be lined with bitumen coated hessian polyethylene kraft paper. Rubberized coir of min. 25mm thickness and 100 mm width shall be nailed to inner surfaces of bottom and 4 sides of the boxes.

11.0 PACKING OF ELECTRICAL ITEMS

11.1 CABLES

11.1.1 **Type of Equipment**
All type of cables..

11.1.2 **Type of Construction**

New or practically new cable drums made of steel and painted with epoxy resin paint are to be used. Cable ends are carefully protected before packing. Over the cables polyethylene sheet shall be wrapped and then sealed properly. Cable drum can be put in wooden crates for ease in transportation and handling. (Wooden cable drum is also acceptable, however vendor to furnish constructional details for approval).

	TITLE	SPECIFICATION NO. PE-TS-888-100-A001		
	TECHNICAL SPECIFICATION FOR SEAWORTHY PACKING FOR EXPORT JOBS	VOLUME II B		
		SECTION D		
		REV. NO. 0	DATE 10/08/2010	
		SHEET 40	OF	52

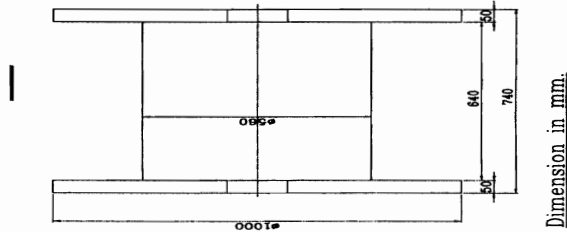
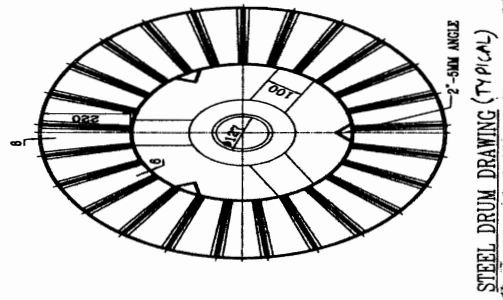

	TITLE	SPECIFICATION NO. PE-TS-888-100-A001	
	TECHNICAL SPECIFICATION FOR SEAWORTHY PACKING FOR EXPORT JOBS	VOLUME II B	
		SECTION D	
		REV. NO. 0	DATE 10/08/2010
		SHEET 41	OF 52

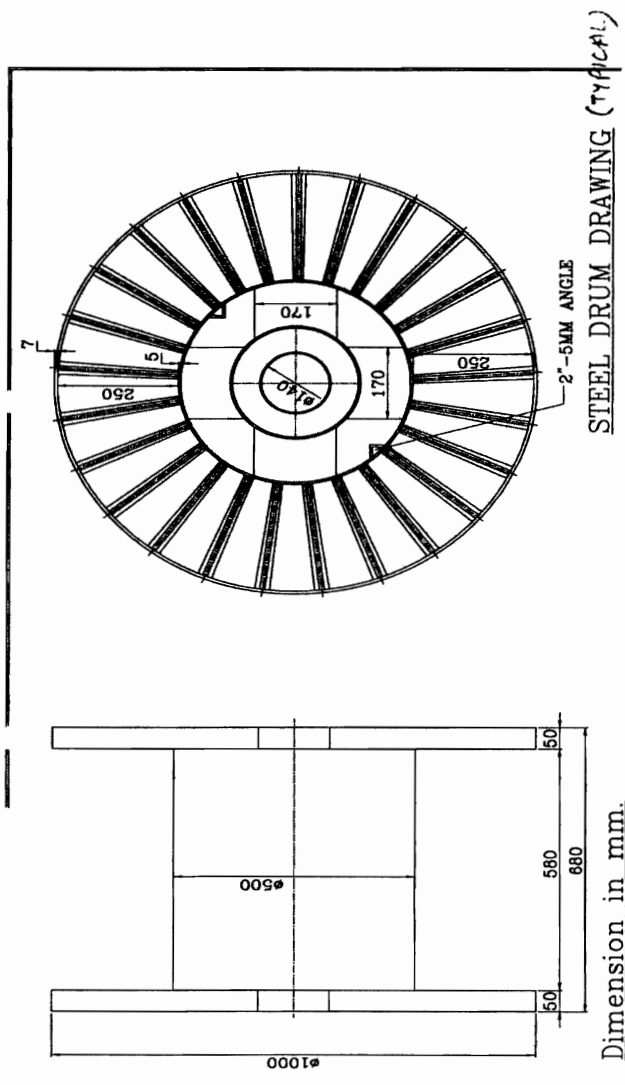

11.2 PACKING OF CABLE TRAYS & ACCESSORIES AND CABLE TRAY SUPPORT MATERIAL

11.2.1 Cable trays can be packed in wooden boxes as per fig 1 to 11 or in steel boxes. Details of steel box construction is as indicated below.

- 1) All Dimensions are in "mm" unless otherwise stated.
- 2) Packing Box shall be fabricated using 50x50x6mm MS Angle, 50x3mm Flat, 2.5 mm thick C Channel, 1mm & 1.6mm Thick sheet.
- 3) Finish of Packing Box Shall be Galvanized.
- 4) Angle & Channel Section forming part of the Main frame shall be welded thoroughly with each other to give a rigid structure.
- 5) Sheet Section and Flat section shall be bolted/ Riveted/ Welded suitably to the Main frame stated in '4' above.

	TITLE	SPECIFICATION NO. PE-TS-888-100-A001	
	TECHNICAL SPECIFICATION FOR SEAWORTHY PACKING FOR EXPORT JOBS	VOLUME II B	
		SECTION D	
		REV. NO. 0	DATE 10/08/2010
		SHEET 42	OF 52

- 6) Welding Portion on galvanized surfaces shall be painted with Zinc Rich Paint.
- 7) Dispatch details such as consignor/consignee address, contract and case details, 'country of origin, port of delivery, stacking instructions shall be written on one of the side of boxes. An anodized aluminium plate as per details and specifications given in page 3 of 5 shall be provided on the boxes
- 8) One copy of packing slip wrapped in polythylene bag covered with suitable aluminium .packing slip holder to be nailed on the external surface of the box. One more copy 9f the packing Slip wrapped in polythylene bag to be kept inside the box at the prominent place.
- 9) **INDICATION MARKS ON THE BOXES:** Markings shall be provided on the boxes indicating position of Boxes for handling, storage and nature of consignment. For guidelines referred page 4 of 5. The ink issued for this purpose as well as for marking dispatch instruction shall be indelible/non-washable marking ink.
- 10) Each item as mentioned in BOQ shall be packed & supplied as a set comprising of required numbers of associated fasteners & hardware etc

	TITLE	SPECIFICATION NO. PE-TS-888-100-A001	
	TECHNICAL SPECIFICATION FOR SEAWORTHY PACKING FOR EXPORT JOBS	VOLUME II B	
		SECTION D	
		REV. NO. 0	DATE 10/08/2010
		SHEET 43	OF 52

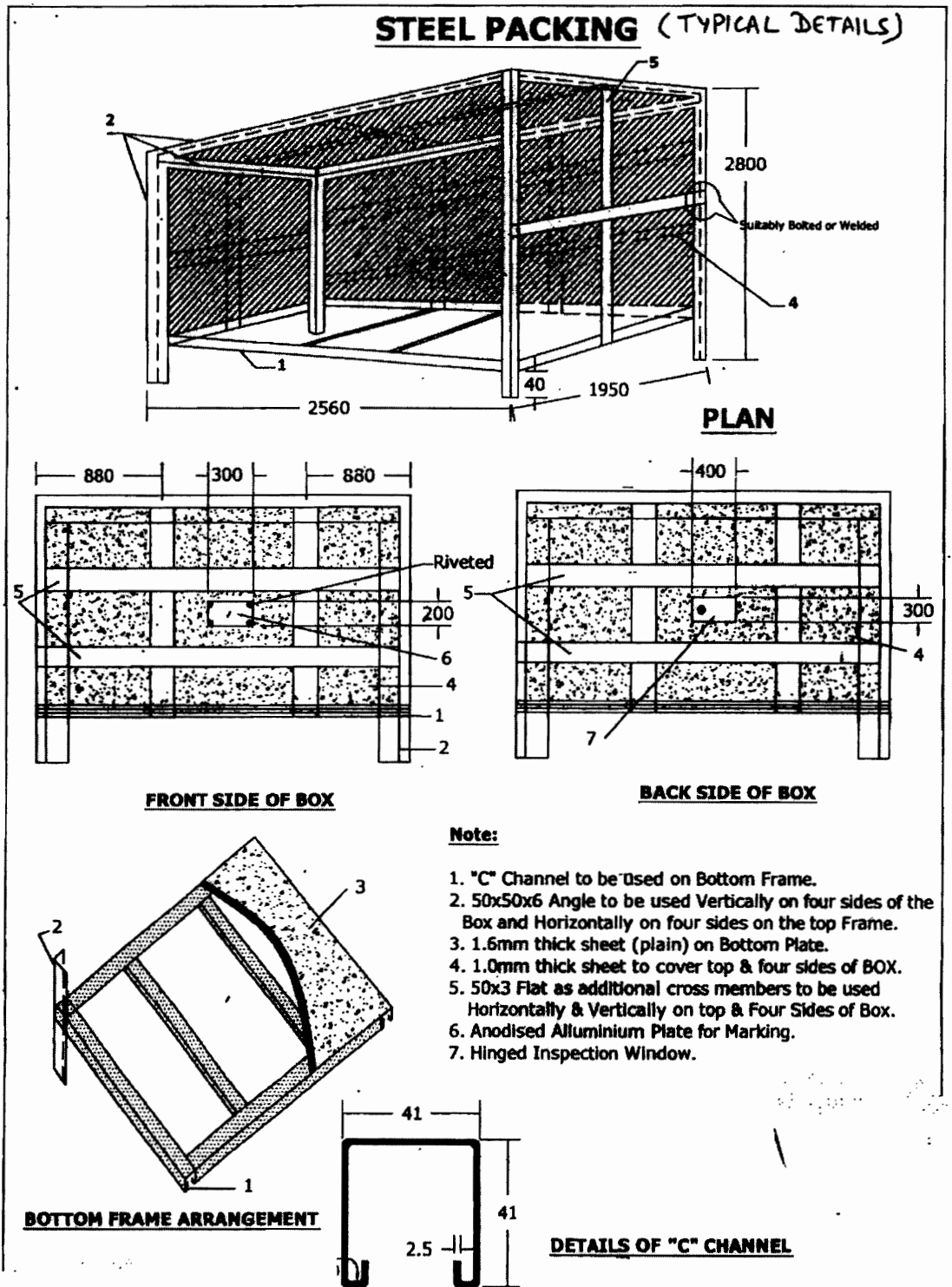

	TITLE	SPECIFICATION NO. PE-TS-888-100-A001	
	TECHNICAL SPECIFICATION FOR SEAWORTHY PACKING FOR EXPORT JOBS	VOLUME II B	
		SECTION D	
		REV. NO. 0	DATE 10/08/2010
		SHEET 44	OF 52

11.3 PACKING FOR STATION LIGHTING SYSTEM

Aspects of packing specific to equipments / items of station lighting system are given here. All other instructions / aspects as per the main specification of export packing which are not covered here shall also be applicable.

11.3.1 For LIGHTING TRANSFORMER, DISTRIBUTION BOARDS, LIGHTING PANELS,

- a) Construction of packing case for LIGHTING DISTRIBUTION BOARDS, LIGHTING PANELS, TRANSFORMER . shall be EITHER as per FIGURE 1,2,3,5,6,7,8,9,10,11 OR FIGURE 14,15,16.
- b) Each Panel/Transformer shall be individually covered with double polythene sheet of thickness 175 microns minimum.
- c) All the 6 inner surfaces of packing shall be nailed with bitumen coated hessian polythene craft paper. Wherever 2 pieces of craft paper are used, the joint shall have minimum overlap of 20mm.

For the top frame it shall be project on all sides by 100mm and shall be nailed on sides .

- d) The gap between the panels and packing case shall be filled with rubberized coir of thickness 50mm minimum and width 100mm. The distance between two consecutive supports of rubberized coir shall be less than 500mm.
- e) Silica get packed in cotton bags shall be placed at different positions inside the packing.
- f) Packing case shall be finally covered with GI sheet of thickness 0.4mm minimum.

11.3.2 For LUMINARIES, RECEPTACLES. EMERGENCY LIGHT, 240/24V TRANSFORMER, CEILING FAN, SWITCH BOARDS, FLEXIBLE CONDUIT, WIRES, EARTH WIRE. JUNCTION BOXES, ERECTION COMMISSIONING SPARES, RECOMMENDED SPARES , ERECTION MATERIAL AND CONSUMABLES

- a) Construction of packing case for THE ABOVE MATERIAL shall be as per FIGURE 1to11.
- b) Items placed inside the case shall be covered with double polythene sheet of thickness 175 microns minimum.
- c) All the 6 inner surfaces of packing shall be nailed with bitumen coated hessian craft paper. wherever 2 pieces of craft paper are used, the joint shall have minimum overlap of 20mm. For the top frame it shall be project on all sides by 100mm and shall be nailed on sides.
- d) Silica get packed in cotton bags shall be placed at different positions inside the packing.

11.3.3 For CONDUIT PIPE

As per international practice pipes are shipped in open bundles with metal strapping. Packing as per attached figure A shall be provided which is described as following:

- a) Each bundle shall be wrapped with 2 layers of 175 microns thick polythene sheet.
- b) Then bundle will be wrapped with bitumen coated hessian craft paper.
- c) Bundle shall be strapped with steel straps.
- d) An anodized aluminium packing description plate as per Figure No. 13 shall be provided.

11.3.4 For POLES

Poles will be wrapped with 2 layers of minimum 175 microns thick polythene sheet and then with bitumen coated hessian craft paper, packed as per Figure – C i.e. bundling.

11.3.5 For STRUCTURAL STEEL

	TITLE TECHNICAL SPECIFICATION FOR SEAWORTHY PACKING FOR EXPORT JOBS	SPECIFICATION NO. PE-TS-888-100-A001	
		VOLUME II B	
		SECTION D	
		REV. NO. 0	DATE 10/08/2010
		SHEET 45	OF 52

Structural steel will be different sizes and shapes. Hence it will be packed as per Figure No. B and described as following :

- a) Each bundle shall be wrapped with 2 layers of 175 microns thick polythene sheet.
- b) Then bundle will be wrapped with bitumen coated hessian craft paper.
- c) Bundle shall be strapped with steel straps.
- d) An anodized aluminium packing description plate as per Figure No. 13 shall be provided.

	TITLE	SPECIFICATION NO. PE-TS-888-100-A001	
	TECHNICAL SPECIFICATION FOR SEAWORTHY PACKING FOR EXPORT JOBS	VOLUME II B	
		SECTION D	
		REV. NO. 0	DATE 10/08/2010
		SHEET 46	OF 52

PACKING PROCEDURE FOR CONDUIT PIPE

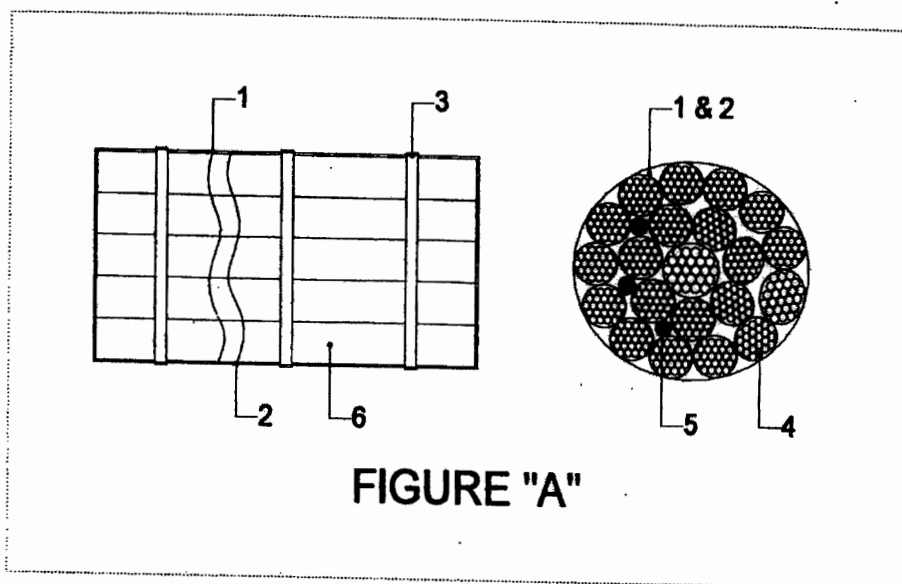

- 1) LAYER OF BITUMEN COATED HESSIAN KRAFT PAPER.
- 2) LAYER OF POLYTHENE SHEET.
- 3) METAL STRAPPING.
- 4) CONDUIT PIPES.
- 5) SILICA GEL POUCHES.
- 6) BUNDLES OF CONDUIT PIPES.

	TITLE	SPECIFICATION NO. PE-TS-888-100-A001	
	TECHNICAL SPECIFICATION FOR SEAWORTHY PACKING FOR EXPORT JOBS	VOLUME II B	
		SECTION D	
		REV. NO. 0	DATE 10/08/2010
		SHEET 47	OF 52

PACKING PROCEDURE FOR STRUCTURAL STEEL

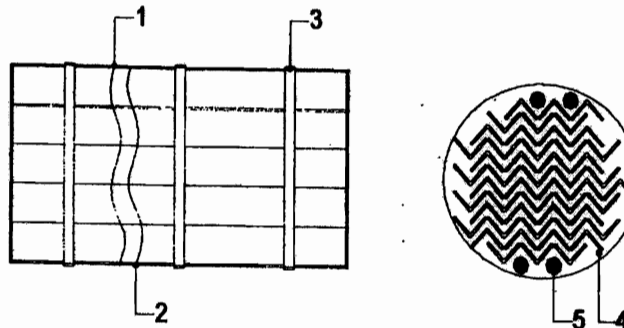

FIGURE "B"

- 1) LAYER OF BITUMEN COATED HESSIAN KRAFT PAPER.
- 2) LAYER OF POLYTHENE SHEET.
- 3) METAL STRAPPING.
- 4) STRUCTURAL STEEL.
- 5) SILICA GEL POUCHES.



TITLE

**TECHNICAL SPECIFICATION
FOR SEAWORTHY PACKING
FOR EXPORT JOBS**

SPECIFICATION NO. PE-TS-888-100-A001		
VOLUME II B		
SECTION D		
REV. NO. 0	DATE 10/08/2010	
SHEET 48	OF	52

packing procedure for poles

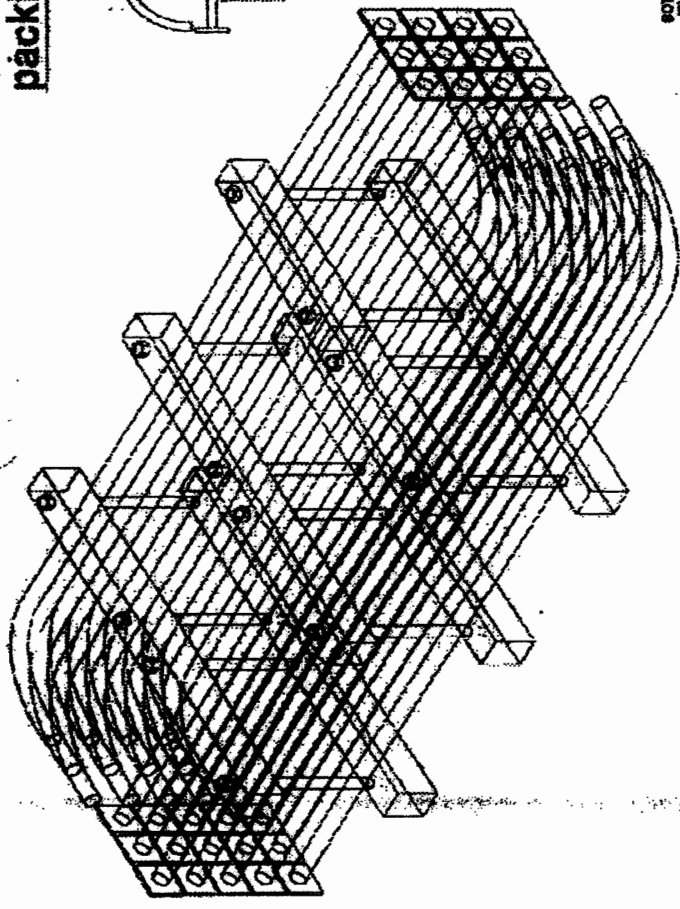
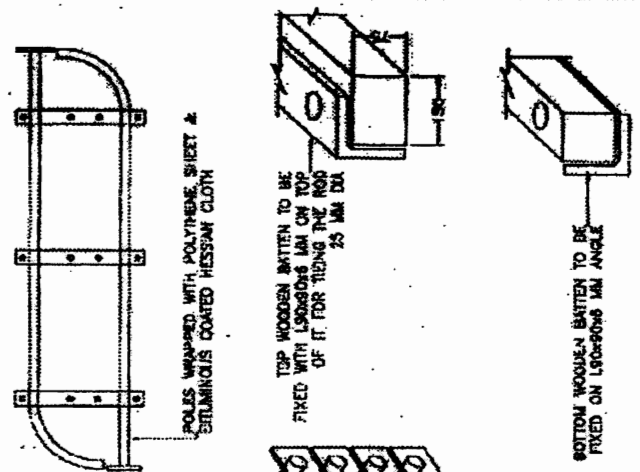



FIGURE "C"

	TITLE	SPECIFICATION NO. PE-TS-888-100-A001	
	TECHNICAL SPECIFICATION FOR SEAWORTHY PACKING FOR EXPORT JOBS	VOLUME II B	
		SECTION D	
		REV. NO. 0	DATE 10/08/2010
		SHEET 49	OF 52

11.4 PACKING FOR DC BATTERY

The packing procedure for seaworthy packing of DC Battery is defined below, which is capable of withstanding impacts, compression, vibration, toppling, sea water spray, prevention against rust, temperature and extreme atmospheric conditions. Aspects of packing specific to equipments / items of DC Battery are given here. All other instructions / aspects as per the main specification of export packing which are not covered here shall also be applicable.

The packing procedure consists of various stages namely primary packing, cushioning, securing, desiccant, outside packing box, Runners/ sliders/ transverse bars of plywood, etc., provided for each movement.

- a) The packing boxes shall be made up of plywood boxes (thickness 9mm min.) with blocks at the bottom of the box for provision for handling the boxes using the forklift. The packing boxes sizes are generally standardized to half-euro size (capable of handling equipment's weight).
- b) Rubberized coir of 25mm thickness shall be provided as cushioning material at the bottom and thermocole of 20mm shall be provided inside on all four sides. Other than this polyethylene film wrap or cover also will be provided. Left out spaces to be filled with rubberized coir/ thermocol to get cushioning effect.
- c) Silica gel in dust free air permeable cotton/paper bag shall be placed in the packing boxes for storage period of 1 year as per IS 304 (1979)
- d) While packing the cells, transit caps (polypropylene) of red and blue shall be used for big size cells for ensuring that cells does not get damaged during the transport due to vibrations etc.
- e) The battery accessories shall be packed with suitable precautions as follows:
 - i) Copper connectors shall be packed after making bunches with lead wire seals to avoid misplacement.
 - ii) Hardware items shall be packed in polyethylene bags (Thickness ≥ 0.175 mm) with item slip
 - iii) Battery rack shall be packed in dismantled condition, wrapped with polyethylene sheet
 - iv) For Ni-Cd type battery, electrolyte in solid form for dry cells shall be packed in cans with KOH, LiOH being packed separately.
 - f) Galvanized Steel straps are provided for binding the packing box sides.
 - g) The handling instructions shall be marked in indelible/ non-washable ink, indicating the upright position.

11.5 PACKING OF SERVICE TRANSFORMERS(OIL FILLED) & ACCESSORIES

This instruction is applicable for packing of transformers (oil filled), its accessories and components so as to ensure safe delivery to end user. Aspects of packing specific to equipments / items of transformers(oil filled) are given here. All other instructions / aspects as per the main specification of export packing which are not covered here shall also be applicable.

11.5.01 PACKING DETAILS :

- a) Items shall be packed in case / crates as per the shipping list.
- b) All fragile items and small items shall be packed in cases and to be marked as "Fragile, handle with care Fragile items".
- c) Fragile accessories are to be first packed in their original boxes (VENDOR's packing). Very

	TITLE	SPECIFICATION NO. PE-TS-888-100-A001	
	TECHNICAL SPECIFICATION FOR SEAWORTHY PACKING FOR EXPORT JOBS	VOLUME II B	
		SECTION D	
		REV. NO. 0	DATE 10/08/2010
		SHEET 50	OF 52

- d small / delicate items such as glass thermometer, door keys shall be packed in separate box.
In case original box is found damaged, suitable alternate box or packing method using felt or foam sheet and polythene wrap to be used.
- e These boxes are then placed in identified wooden boxes. Inside of such boxes are lined with a layer of polythene sheet, packing wool / grass and another layer of polythene sheet before placing the boxes. All boxes are then wrapped with this polythene sheet before closing the box. Fragile items shall not be placed loose, one above the other inside the case.
- f All wiring cables, connection flats of non-ferrous materials, CTs, valves bellows shall also be packed.
- g Items like CTs, Oil communicating bushings, insulators, wired equipments and housings such as RTCC Panel, M. Box, Drive Mechanism, thermometers, gauges shall be wrapped in polythene from all around.
- h Buchholz relay and OSR relay openings will be blanked using covers, before putting them in the box
- i Items shall be carefully lowered and arranged inside the crate / case and each item shall be locked from all sides in such a way to avoid its movement in any way. Wooden stoppers and separators shall be provided for this and nailed to the crate / case wood.
- j Wooden planks and batons in contact with fragile items shall be provided with kit foam at the locations of contact.
- k Oil communication bushings shall be packed in separate case on V or U shape wooden felted supports, as in case of condenser bushings.
- l While placing and arranging the items inside the crates / cases, these shall be verified for correctness and then the packing note shall be signed. The cover top of the crate / case shall then be closed.
- m The main equipment like transformer tank shall be packed suitably to prevent any damage during transit / storage. Support structures like frame, header supports etc. shall be crated. Conservator headers shall also be crated. Radiators pipe work and other instruments & components shall be packed in cases. All the cases shall be lined with polythene from inside.

11.6 ALTERNATIVE PACKING CASES FOR CONTROL PANELS AND SWITCH GEARS

For Control and switch gear panels, construction of wooden packing cases may be provided as per fig 14 & 15 and as detailed below.

Thickness of planks for all sides, binding and jointing battens shall be at least 25 mm. Width of the plank shall be at least 125mm and that of binding and jointing planks shall be at least 100mm.

Top frame shall be suitable so that it does not collapse due to sandwiching between slings while lifting. Longitudinal and traverse bars for the bottom wooden pallet to be suitably selected.

Diagonal bracings shall be as per cl 9.3.1.3 and all other requirements shall be as per clauses 9.3.1.4 to 9.3.1.6.

12.0 Containerization

As required by BHEL, the VENDOR shall stuff the GOODS into 20 or 40 foot containers (dry, open top, flat racks, etc.).

The maximum inside dimensions of containers are to be considered:

	TITLE	SPECIFICATION NO. PE-TS-888-100-A001	
	TECHNICAL SPECIFICATION FOR SEAWORTHY PACKING FOR EXPORT JOBS	VOLUME II B	
		SECTION D	
		REV. NO. 0	DATE 10/08/2010
		SHEET 51	OF 52

- 40 foot containers: 11.80 m x 2.20 m x 2.05 m
- 20 foot containers: 5.80 m x 2.20 m x 2.05m
-

The present definition of containerization is valid for sea containers only. Vendor to check the size of containers before start of packing of equipment.

12.1 Protection of Cases/Crates

Since shipping containers are in general not water tight, packing in contact with the floor of the container shall be raised in order to prevent it from being damaged by the accumulation of water.

12.2 Mechanical Constraints

The mechanical constraints for "general use" closed containers are of a different nature (height of "stacking" being limited inside the containers), the packing for the GOODS may be of a lighter structure. However, it is necessary that the packing be appropriate so as to protect the GOODS on site during the storage period, as required after discharging of the GOOD'S from the containers.

Note:

It is the responsibility of the VENDOR to ensure that the cases/crates are stowed, secured and fastened inside the container. The VENDOR will take all necessary precautions to conform to the maximum weight allowed and the centre of gravity of the container. The securing and fastening of the cases/ crates can be carried out by nailing timbers on the bottom or on the vertical sides of the container.

13.0 Other Services to be provided by Vendor

In addition to the packing and shipping documents, VENDOR must also carry out the following services, which shall be included in his quotation:

Carriage of VENDOR's sub-contracted equipment and material, which must be re-grouped in VENDOR's or PACKER's workshops, whilst waiting for packaging.

BHEL reserves the right to postpone the shipping of the GOODS. In this event, any storage and insurance costs during the first ninety (90) days shall be borne by the VENDOR.

Loading, including lifting, securing, lashing, and stowing, of all cases, crates, or packages onto means of transportation such as, but not limited to, trailers, containers, etc.

14.0 Responsibilities and Guarantees

VENDOR is responsible for the choice of category for packing according to the transport facilities used, and on the basis of the present document. In case of doubt or disagreement regarding the choice, VENDOR must inform BHEL prior to packing and await BHEL's approval. All phases of packaging, marking, loading, etc. will be subject to BHEL inspection.

BHEL reserves the right to reject the packing when the packing does not conform to these instructions and/or when the packing does not ensure perfect protection of the GOODS. VENDOR is responsible for the weights and dimensions declared, and the marking of the packages.

The documents must be in strict conformity with the packing contents.

The packing specified in these "Packing, Marking and Shipping Instructions" is guaranteed for a twelve (12) months storage period after delivery on site.

VENDOR is responsible for providing storage recommendation adapted to the GOODS. According to this guarantee, VENDOR is held responsible in the event of goods becoming

	TITLE	SPECIFICATION NO. PE-TS-888-100-A001	
	TECHNICAL SPECIFICATION FOR SEAWORTHY PACKING FOR EXPORT JOBS	VOLUME II B	
		SECTION D	
		REV. NO. 0	DATE 10/08/2010
		SHEET 52	OF 52

useless, damaged or broken, as a result of poor packing and/or stowing, or due to corrosion, subsequent to insufficient or inadequate protection. All direct or indirect costs resulting thereof, will be back-charged to VENDOR.

2) Class No. and Fluid Designation

CLASS NO.	FLUID NAME	SYMBOL	
AA60	Gypsum Slurry	GS	
	Filtrate Slurry	FS	
	Waste Water	WW	
	Duct Drain	DD	
	Beltfilter Vent Gas	VBG	
BA01	Instrument Air	AI	
	Lube Oil (Low Pressure)	LOL	
CC01	Process Water	WP	Note 1
	Raw Water	WR	
	Cooling Water Supply	WCS	
	Cooling Water Return	WCR	
	Vacuum Pump Vent	VG	
	Antifoam Agent	AA	

Note I

Class AA60 shall be applied for process water service line in contact with corrosive and abrasive media.

3) Abbreviations

Abbreviations used throughout this specification are as follows:

BB	:	Bolted Bonnet
BC	:	Bolted Cover
BE	:	Bevel End
BW	:	Butt Weld
CAL	:	Calculation
CR	:	Chloroprene Rubber
E	:	Electric Resistance Weld
EPDM	:	Ethylene Propylene Diene Methylene Rubber
Eq	:	Equal
FE	:	Flange End
FF	:	Flat Face
G. OP	:	Gear Operation
Gal.	:	Galvanized
HEX.	:	Hexagon
IIR	:	Isobutylene Isoprene Rubber

ISRS	:	Inside Screw Rising Stem
La	:	Larger
L.OP	:	Lever Operation
NB	:	Nominal Bore
NW	:	Nozzle Weld
OS&Y	:	Outside Screw & York
PE	:	Plane End
PP	:	Poly Propylene
PTFE	:	Poly Tetra Fluoro Ethylene
RF	:	Raised Face
R/L	:	Rubber lined or rubber seated
S	:	Seamless
SB	:	Screw Bonnet
SC	:	Screw Cover
SCH	:	Schedule No.
SCR'D	:	Screwed
Sm	:	Smaller
SO	:	Slip On
St.	:	Stellite
SW	:	Socket Weld
W	:	Weld
WN	:	Welding Neck
W/LINING	:	With Lining
V#	:	Valve No.
13 CR	:	13% CHROMIUM

CLASS	Max. Press. (MPaG)		1.1		C. A. mm	CLASS
AA60 (1/1)	Max. Temp. (degC)		65			AA60 (1/1)
FLUID	GYPSUM SLURRY					
ITEM	Size	Thickness	Specification			ITEM No.
PIPING	DN25 – DN50	SCH40	A53-B SML PE (I:R/L) ASME			
	DN65 – DN150	SCH40	A53-B E. R. W BE (I:R/L) ASME			
	DN200 – DN300	SCH20	A53-B E. R. W BE (I:R/L) ASME			
	DN350 – DN400	SCH10	A53-B E. R. W BE (I:R/L) ASME			
	DN450 – DN500	SCH10	A53-B E. R. W BE (I:R/L) ASME			
	DN550 – DN1000	7.9T	A134 (A283-C) EFW BE (I:R/L) ASME			
	DN1100– DN1200	9.5T	A134 (A283-C) EFW BE (I:R/L) ASME			
FITTING	DN25 – DN50	Suit to PIPE	BW A234-WPB (I:R/L) ASME-B16.9			
	DN65 – DN150	Suit to PIPE	BW A234-WPBW (I:R/L) ASME-B16.9			
	DN200 – DN300	Suit to PIPE	BW A234-WPBW (I:R/L) ASME-B16.9			
	DN350 – DN500	Suit to PIPE	BW A234-WPBW (I:R/L) ASME-B16.9			
	DN550 – DN1000	Suit to PIPE	BW A134 (A283-C) EFW (I:R/L) ASME-B16.9			
	DN1100– DN1200	Suit to PIPE	BW A134 (A283-C) EFW (I:R/L) ASME-B16.9			
SMOOTH BEND	DN25 – DN80	Suit to PIPE	BW A53-B (I:R/L)			
FLANGE	DN25 – DN600		SO A105 ASME150 SO FF (I:R/L) ASME-B16.5			
	DN650 – DN1800		SO A105 AWWA CL. B SO FF (I:R/L) AWWA-C207			
PINCH VALVE	DN25 – DN150		PN 16 A126-B TRIM-13CR SLEEVE-CR LINING-IIR FF HAND WHEEL			
GASKET	DN25 – DN600		V-2000 RUBBER RUBBER OR EQ. ASME150 2.0T FLAT RING			
	DN650 – DN1800		V-2000 RUBBER RUBBER OR EQ. AWWA CL. B 2.0T FLAT RING			
BOLT & NUT	ALL SIZE		STUD U HEAVY NUT A307-GR. B/A563-GR. A FINISHED			
Note: I: R/L - Replaceable Wear Resistant Natural Rubber Lining of minimum 6mm thickness. Additional thickness of 2 mm rubber lining shall be provided in bends.						

CLASS	Max. Press. (MPaG)	1		C. A. mm
BA01 (1/1)	Max. Temp. (degC)	45		
FLUID	INSTRUMENT AIR, LUBE OIL			
ITEM	Size	Thicknes s	Specification	
PIPING	DN6- DN50	SCH40S	A312-TP304 SML PE ASME	
	DN65-DN250	SCH20S	A312-TP304 E. R. W BE ASME	
FITTING	DN6 - DN50	Suit to PIPE	3000LB SW A182-F304 ASME-B16.11	
	DN65 - DN250		BW A403-WP304 ASME-B16.9	
FLANGE	DN6 - DN50	Suit to PIPE	SW GR. 304 GR. 304 ASME150 SW RF ASME-B16.5	
	DN65 - DN250		LOOSE A105 ASME150 LOOSE ASME-B16.5	
GATE VALVE	DN6 - DN50		API-602 PN 16 A182-F304 AISI304 SW BB, OS&Y HAND WHEEL	
	DN65 - DN250		ASME-B16.34 PN 16 A351-CF8 AISI304 RF BB, OS&Y HAND WHEEL	
GASKET	DN6 - DN150		V-6500 NON-ASBESTOS OR EQ. ASME150 1.5T FLAT RING	
	DN200- DN250		V-6500 NON-ASBESTOS OR EQ. ASME150 3.0T FLAT RING	
BOLT & NUT	ALL SIZE		STUD U HEAVY NUT A307-GR. B/A563-GR. A FINISHED	

CLASS	Max. Press. (MPaG)	0.11	0.85		C. A. mm
CC01 (1/1)	Max. Temp. (degC)	155	45		
FLUID	WATER, VENT GAS				
ITEM	Size	Thickness	Specification		
PIPING	DN6 - DN50	SCH80	A53-B SML PE ASME		
	DN65 - DN150	SCH40	A53-B E. R. W BE ASME		
	DN200 - DN300	SCH20	A53-B E. R. W BE ASME		
FITTING	DN6 - DN50		3000LB SW A105 ASME-B16.11		
	DN65 - DN150	Suit to PIPE	BW A234-WPB ASME-B16.9		
	DN200 - DN300		BW A234-WPB ASME-B16.9		
FLANGE	DN6 - DN150	Suit to PIPE	SO A105 ASME150 SO RF ASME-B16.5		
	DN200 - DN300		SO A105 ASME150 SO RF ASME-B16.5		
GATE VALVE	DN6 - DN50		API-602 PN16 A105 13CR SEAT STL SW BB, OS&Y HAND WHEEL		
	DN65 - DN300		ASME-B16.34 PN16 A395 13CR RF BB, OS&Y HAND WHEEL		
GLOBE VALVE	DN6 - DN50		API-602 PN16 A105 13CR SEAT STL SW BB, OS&Y HAND WHEEL		
	DN65 - DN300		ASME-B16.34 PN16 A395 13CR RF BB, OS&Y HAND WHEEL		
CHECK VALVE	DN6 - DN50		API-602 PN16 A105 13CR SEAT STL SW BC, LIFT		
	DN65 - DN300		ASME-B16.34 PN16 A395 13CR RF BC, SWING		
BALL VALVE	DN6 - DN100		ASME-B16.34 PN16 A105 AISI304 RF BALL LEVER. FULL BORE		
BUTTERFLY VALVE	DN50 - DN150		ASME-B16.34 PN16 A216-WCB 13CR EPDM RF WAFER WAFER LEVER.		
	DN50 - DN150		ASME-B16.34 PN16 A216-WCB 13CR EPDM RF WAFER WAFER AIR CYLINDER W/L. SWITCH		
	DN50 - DN150		ASME-B16.34 PN16 A216-WCB 13CR EPDM RF WAFER WAFER ELECTRIC MOTOR W/L. SWITCH		
	DN200 - DN300		ASME-B16.34 PN16 A216-WCB 13CR EPDM RF WAFER WAFER WHEEL WITH GEAR		
	DN200 - DN300		ASME-B16.34 PN16 A216-WCB 13CR EPDM RF WAFER WAFER AIR CYLINDER W/L. SWITCH		
	DN200 - DN300		ASME-B16.34 PN16 A216-WCB 13CR EPDM RF WAFER WAFER ELECTRIC MOTOR W/L. SWITCH		
GASKET	DN6 - DN150		V-6500 NON-ASBESTOS OR EQ. ASME150 1.5T FLAT RING		
	DN200 - DN300		V-6500 NON-ASBESTOS OR EQ. ASME150 3.0T FLAT RING		
BOLT & NUT	ALL SIZE		STUD U HEAVY NUT A307-GR. B/A563-GR. A FINISHED		



3x800 MW PATRATU TPS
GYPHUM DEWATERING EQUIPMENT
TECHNICAL SPECIFICATION

SPECIFICATION No: PE-TS-434-571-A901

SECTION: II

REV. 00

Page: 1 of 6

SECTION - II
STANDARD TECHNICAL SPECIFICATION

	3x800 MW PATRATU TPS	SPECIFICATION No: PE-TS-434-571-A901	
	GYPSUM DEWATERING EQUIPMENT	SECTION: II	
	TECHNICAL SPECIFICATION	REV. 00	
		Page: 2 of 6	

1.0	STANDARD TECHNICAL REQUIREMENTS – EQUIPMENTS/ COMPONENTS OF GDE
I	DESIGN CONSTRUCTION –VACUUM BELT FILTERS
1.	The vacuum belt filter shall be proven design in operation for similar capacities. The filter cloth shall be polyester or polypropylene as per the proven design of the supplier and shall be guaranteed for a minimum life of not less than 7000 hrs.
2.	The complete frame of the filter and all parts in contact with gypsum shall be made of corrosion resistant material.
3.	In case, the contractor offers a design with an underlying belt for carrying the filter cloth, the same shall be endless, factory vulcanized rubber belts. The belt shrouds and the sealing belts shall provide a leak tight arrangement to prevent overflow of gypsum slurry. The sealing belt shall have minimum life of not less than 7000 hrs.
4.	The vacuum box shall ensure tight sealing with the belt/cloth and shall be of proven design. The material of construction of the Vacuum Box shall be preferably UHMW-PE (Ultra High Molecular Weight – Poly Ethylene). Bidder may offer alternate material proven for the specified chloride content of the slurry.
5.	The belt filter shall have an automatic cloth tracking mechanism and shall be provided with all required instrumentation as per the supplier's proven practice. The belt filter shall have an automatic cloth tensioning mechanism.
6.	The filter shall be provided with minimum 2 stages of cake washing for removing impurities in the gypsum. One stage of cloth washing arrangement shall also be provided.
7.	The service factor of the gear unit (if any) shall be minimum 1.5.
8.	Piping and wiring within the skid should be in the vendor's scope.
9.	Nozzles and connections The suction and discharge pipes will be flanged and will have the same nominal test procedure as the body of the pump. Threaded connections are not admitted in these pipes.
10	The flanges shall comply with the following standards: <ul style="list-style-type: none"> - Steel flanges as per ANSI B16.5 (raised face type, at least class 150) - Cast iron flanges as per ANSI 16.1 (flat face type, at least class 125) The pipe shall be designed according to API676 with regards to the force.
II	DESIGN AND CONSTRUCTION OF VACUUM PUMPS
1)	The mechanical vacuum pumps and accessories shall be used for continuous duty, to create and maintain vacuum by removing air and other non-condensable gases with associated water vapour, from the vacuum belt during gypsum dewatering operation. Final selection should consider compatible operation of the GDW Equipment & pump over the full range of anticipated operation.
2)	The pumps shall be of single stage or two stage liquid ring type with suitable compression ratio, to meet the all operating condition, ensuring no cavitation's under all operating conditions. Bidder shall indicate the arrangement being offered to avoid cavitation.
3)	The pump shall be of liquid ring design with both the stages (if it is a two-stage pump) mounted on a common shaft. The unit shall require no external lubrication and shall not be damaged by slugs of water and entrained gases.
4)	Each pump unit with the accessories shall be furnished as a package unit mounted on a common steel base plate.

	3x800 MW PATRATU TPS	SPECIFICATION No: PE-TS-434-571-A901	
	GYPSUM DEWATERING EQUIPMENT	SECTION: II	
	TECHNICAL SPECIFICATION	REV. 00	
	Page: 3 of 6		

	<p>5) The pumps shall be connected to its motors by flexible couplings. All couplings shall have suitable rigid steel coupling guards having closed ends and anchored to the base plate.</p> <p>6) The materials of construction of all the parts including all accessories shall be suitable to the fluids being handled/ used.</p> <p>7) Impeller Tip speed to be kept in range of 13-22 m/sec.</p> <p>8) Pipe fittings: not less than Schedule 40</p> <p>Material of Construction of Vacuum Pump: MOC of vacuum pump shall be as below mentioned or better material:</p> <p>1) Casting: ~ 2% Ni Cast Iron (GB 9439, HT 250)/ASTM A48, CLASS35</p> <p>2) Shaft: Carbon Steel, En-8 or better</p> <p>3) Impeller: Nodular Iron (ASTM A536, Gr.65-45-12) or better</p> <p>4) Shaft Sleeve :(If applicable) Stainless Steel</p>
b)	Shaft
	The critical speed shall be well away from the operating speed and in no case less than 130% of the rated speed. The shaft shall be ground and polished to final dimensions and shall be adequately sized to withstand all stresses from rotor weight, hydraulic loads, vibration and torques coming in during operation.
c)	Shaft Sleeves
	Renewable type fine finished shaft sleeves shall be provided at mechanical seals. Shaft sleeves shall be fastened to the shaft to prevent any leakage or loosening. Shaft and shaft sleeve assembly should ensure concentric rotation.
d)	Bearings
	Heavy duty bearings, adequately designed for the type of service specified in the enclosed pump data sheet and for long, trouble free operation shall be furnished. The bearings offered shall be capable of taking both the radial and axial thrust coming into play during operation. In case, sleeve bearings are offered additional thrust bearings shall be provided. Antifriction bearings of standard type, if provided, shall be selected for a minimum life 20,000 hrs. of continuous operation at maximum axial and radial loads and rated speed. Proper lubricating arrangement for the bearings shall be provided. The design shall be such that the bearing lubricating element does not contaminate the liquid pumped. Where there is a possibility of liquid entering the bearings suitable arrangement in the form of deflectors or any other suitable arrangement must be provided ahead of bearings assembly. Bearings shall be easily accessible without disturbing the pump assembly. A drain plug shall be provided at the bottom of each bearings housing.
e)	Mechanical Seals
	Mechanical seals shall be of single type with either sliding gasket or bellows between the axially moving face and shaft sleeves or any other suitable type. The sealing faces should be highly lapped surfaces of materials known for their low frictional coefficient and resistance to corrosion against the liquid being pumped.

	3x800 MW PATRATU TPS	SPECIFICATION No: PE-TS-434-571-A901	
	GYPHUM DEWATERING EQUIPMENT	SECTION: II	
	TECHNICAL SPECIFICATION	REV. 00	
		Page: 4 of 6	

	<p>The pump supplier shall coordinate with the seal maker in establishing the seal chamber of circulation rate for maintaining a stable film at the seal face. The seal piping system shall form an integral part of the pump assembly. For the seals under vacuum service, the seal design must ensure sealing against atmospheric pressure even when the pumps are not operating. Necessary provision for seal water supply along with complete piping fittings and valves as required shall form integral part of pump supply.</p>
f)	Pump Shaft Motor Shaft Coupling
	<p>The pump and motor shafts shall be connected with an adequately sized flexible coupling of proven design with a spacer to facilitate dismantling of the pump without disturbing the motor. Necessary coupling guards shall also be provided.</p>
g)	Base Plate
	<p>A common base plate mounting both for the pump and motor shall be furnished. The base plate shall be fabricated steel and of rigid construction, suitably ribbed and reinforced. Base plate and pump supports shall be so constructed and the piping unit so mounted as to minimize misalignment caused by mechanical forces such as normal piping strain, internal differential thermal expansion and hydraulic piping thrust. Suitable drain troughs and drip lip shall be provided.</p>
h)	Drive Motor (Prime Mover)
	<p>The kW rating of the drive shall be based on continuously driving the connected equipment for the conditions specified.</p>
III	GYPHUM DISCHARGE CHUTE
a)	<p>The minimum valley angle of chutes shall be 60 degrees at the feeding point to guide the material in the direction of belt travel. Transfer chutes shall be adequately sized and sloped to ensure smooth flow of Gypsum without any accumulation anywhere.</p>
b)	<p>Chutes shall be made of minimum 20 mm thick TISCRAI / SAILHARD/ LSLAS07 or equivalent material. All chutes should have one inspection door at every floor and for the ones in between the floors (more than 1.5 meter above the operating floor level) suitable access for trouble free maintenance shall be provided. For sealing of inspection doors labyrinth type arrangement to be provided.</p>
c)	<p>Complete chute work in the region of flap gates (if applicable) shall be fabricated from 20 thk TISCRAI or equivalent. In case of vertical chute (valley angle more than 80 degree) complete chute, work shall be of 20 mm thick TISCRAI or equivalent material. While finalizing the chute work inside the building, arrangement for shifting and replacing chute legs, proper handling arrangement/wall openings, trolleys, hoists shall also be provided. While fabricating the chute, no welds in between shall be allowed.</p>
	<p>One (1) no. chute blockage switch for each belt filter of proven type (subject to approval of the employer) shall be provided. Chute blockage switch shall trip the feeding conveyor in case of Chute blockage and protect the feeding conveyor equipment.</p>
IV	PIPING
a)	<p>The slurry pipes shall be sized to minimize erosion and avoid settling of the gypsum at all load operation. Slurry pipes shall be designed to keep the velocity above the settling velocity under all operating conditions. The bidder may provide a recirculation line with motorized isolation valve for the above purpose. All the pipes handling slurry shall be provided with replaceable rubber lining of proven quality. The slurry pipes shall be lined with replaceable wear resistant natural rubber lining of minimum 6 mm thickness. Additional thickness of 2 mm in rubber lining shall be provided at bends. The bidder can provide slurry pipes of size lower than 300 NB made up of FRP material (silicon carbide coating on slurry exposed surface) if it has previous experience of providing the same. Outer surface of the pipes should be fire retardant. All the rubber-lined pipes shall be of flanged connection.</p>

	3x800 MW PATRATU TPS	SPECIFICATION No: PE-TS-434-571-A901
	GYPSUM DEWATERING EQUIPMENT	SECTION: II
	TECHNICAL SPECIFICATION	REV. 00
		Page: 5 of 6

b)	Valves shall be of proven type and type contractor shall submit details valve schedule for employer's approval. Reference list for previous installations for similar application shall also be furnished to the employer.
c)	The isolation valves provided in all the slurry lines shall be of knife gate type/butterfly type unless specifically mentioned. Motorized actuators shall be provided for valves requiring frequent operation as indicated in the relevant scheme.
d)	Necessary arrangements for purging & flushing of all the process pipelines, equipments etc. shall be required.
e)	Belt filter washing pumps shall have a minimum flow line to tank with a restriction orifice.
f)	All Lube oil , Instrument Air piping shall be made up of Gr.304 Stainless Steel material.
g)	All process water & Cooling water piping shall be made up of Carbon Steel Pressure Piping.
V	PROCESS/CLARIFIED WATER PUMPS
	<p>The cake/cloth wash pumps shall be horizontal centrifugal type designed for continuous operation with semi-open or closed impeller. Casing, Gland and Stuffing Box shall be of 2.5 Ni Cast Iron to IS:210 Grade FG 260 or equivalent. Impeller, wearing rings (as applicable) shall be of Stainless Steel -316 grade and Shaft & Shaft sleeves shall be of SS-410 grade. Pump re-circulation line shall be provided for pumping system. Pumps shall be provided with accessories such as Y-type suction strainers, Coupling guard, drain plugs, vent valves etc.</p> <p>MOC of Filtrate Extraction Pumps as follows:</p> <p>a) Casing: 1. Ductile Iron (65-45-12, ASTM A536) with replaceable rubber liner-14000 hours to be guaranteed.</p> <p style="text-align: center;">OR</p> <p>2. Ductile Iron with Hi Chrome liner – 14000 hours to be guaranteed.</p> <p style="text-align: center;">OR</p> <p>3.</p> <p>a) Hi Chrome (ASTM 532 Grade IIIA) - 24000 hours to be guaranteed. b) Impeller: Hi Chrome or superior material with 14000 hours guarantee. c) Solid Shaft: Duplex 2205 /EN8D /EN9 d) Shaft sleeve at mechanical seal: CD4MCU ASTM A 743/ Duplex 2205 e) Base Plate: Carbon steel with Epoxy Coating</p> <p>Bidder shall provide MOC of proven design to be approved during detailed engineering as per equipment/system/process requirement. The material and thickness of the liners shall ensure a minimum service life of 2 years before replacement.</p>
VI	GENERAL
a)	<p>Cake/Cloth Wash pump shall be 1500/3000 RPM. The Vacuum Pump is a low speed machine and the RPM shall be selected by the bidder meeting the equipment/system requirement.</p> <p>Bidder to note that above shall be subject to BHEL/BHEL's Customer approval during contract stage.</p>
b)	For gypsum, the bulk density shall be taken as 900 kg/m ³ for volumetric computation and 1250 kg/m ³ for torque and drive requirements. Refer respective P&IDs for Slurry details.

	3x800 MW PATRATU TPS	SPECIFICATION No: PE-TS-434-571-A901	
	GYPSUM DEWATERING EQUIPMENT	SECTION: II	
	TECHNICAL SPECIFICATION	REV. 00	
	Page: 6 of 6		

c)	The slurry pumps shall be provided with motorized/ pneumatic suction and discharge valves. In addition, flushing water lines with motorized valves shall be provided for each pump for automatic flushing of the pump after each shut down. The flushing water for the pumps shall be taken from the process water supply.
d)	The slurry pump casing should be radially split to allow easy removal of impeller.
e)	Customer approval shall be a requirement in case of difference of opinion.

	3x800 MW PATRATU TPS	SPECIFICATION No: PE-TS-434-571-A901	
	GYPSUM DEWATERING EQUIPMENT TECHNICAL SPECIFICATION	SECTION : III	
	LIST OF DOCUMENTS TO BE SUBMITTED WITH BID	ANNEXURE : 1	
		REV: 00	
		SHEET 1 OF 1	

ANNEXURE - 1

DRAWINGS / DOCUMENTS TO BE SUBMITTED WITH THE BID

Bidder should submit the filled up (wherever applicable), signed and stamped copy of the following documents along with the offer/ bid for technical evaluation:

Sl. No.	Reference	Description
1.	Annexure-2	COMPLIANCE CUM CONFIRMATION CERTIFICATE
2.	Annexure-3	PRE-BID CLARIFICATION SCHEDULE
3.	Annexure-4	DEVIATION SHEET (COST OF WITHDRAWAL)
4.	Annexure-5	SCHEDULE OF GUARANTEES
5.	Annexure-6	LIST OF MAKES OF SUB VENDOR ITEMS
6.	Annexure-7	LIST OF TOOLS & TACKLES
7.	Annexure-8	EQUIPMENT DATA SHEET/ SCHEDULE (TO BE FILLED BY BIDDER)
8.	Annexure-9	LIST OF COMMISSIONING SPARES
9.		UNPRICED SCHEDULE IN THE PRICE FORMAT ISSUED ALONG WITH TENDER



3x800 MW PATRATU TPS

**GYPSUM DEWATERING EQUIPMENT
TECHNICAL SPECIFICATION**

**COMPLIANCE CUM CONFIRMATION
CERTIFICATE**

SPECIFICATION No: PE-TS-434-571-A901

SECTION : III

ANNEXURE : 2

REV. 00

SHEET: 1 OF 2

COMPLIANCE-CUM-CONFIRMATION CERTIFICATE

The bidder shall confirm compliance with following by signing / stamping this compliance certificate (every sheet) and furnish same with the offer.

- a) The scope of supply, technical details, construction features, design parameters etc. shall be as per technical specification & there are no exclusions, other than those mentioned under "exclusion and those resolved as per 'Schedule of Deviations', with regard to same.
- b) There are no other deviations w.r.t. specifications other than those furnished in the 'Schedule of Deviations'. Any other deviation, stated or implied, taken elsewhere in the offer stands withdrawn unless specifically brought out in the 'Schedule of Deviations'.
- c) Bidder shall submit QP in the event of order based on the guidelines given in the specification & QP enclosed therein. QP will be subject to BHEL / CUSTOMER approval & customer hold points for inspection / testing shall be marked in the QP at the contract stage. Inspection / testing shall be witnessed as per same apart from review of various test certificates/ Inspection records etc. This is within the contracted price without any extra implications to BHEL after award of the contract.
- d) All drawings/ data-sheets / calculations etc. submitted along with the offer, if not sought/required for bid evaluation shall not be taken cognizance off.
- e) The offered materials shall be either equivalent or superior to those specified in the specification & shall meet the specified / intended duty requirements. In case the material specified in the specifications is not compatible for intended duty requirements, the same shall be resolved by the bidder during the pre-bid discussions, otherwise BHEL/Customer's decision shall be binding on the bidder, whenever the deficiency is pointed out.

For components where materials are not specified, the same shall be suitable for intended duty, all materials shall be subject to approval in the event of order.

- f) The commissioning spares shall be supplied on 'As Required Basis' & prices for same are deemed to be included in the base price.
- g) All sub-vendors shall be subject to BHEL / CUSTOMER approval in the event of order.
- h) Guarantee/Warranty for plant/equipment shall be as per relevant clause of GCC / SCC / other Commercial Terms & Conditions.
- i) In the event of order, all the material required for completing the job at site shall be supplied by the bidder within the ordered price even if the same are additional to approved billing break-up, approved drawing or approved Bill of quantities within the scope of work as tender specification. This clause will apply in case during site commissioning, additional



3x800 MW PATRATU TPS

GYP SUM DEWATERING EQUIPMENT TECHNICAL SPECIFICATION

COMPLIANCE CUM CONFIRMATION CERTIFICATE

SPECIFICATION No: PE-TS-434-571-A901

SECTION : III

ANNEXURE : 2

REV. 00

SHEET: 2 OF 2

requirements emerges due to customer and / or consultant's comments. No extra claims shall be put on this account.

- j) Schedule of drawings/documents/quality plans submission, comment incorporation & approval shall be as stipulated elsewhere in the specification. The successful bidder shall depute his design personnel to BHEL's / Customer's / Consultant's office for across the table resolution of issues and to get documents approved in the stipulated time.
- k) As-built drawings shall be submitted as and when required during the project execution.
- l) The bidder has not tampered with this compliance-cum-confirmation certificate and if at any stage any tampering in the signed copy of this document is noticed then same shall be treated as breach of contract and suitable actions shall be taken against the bidder.
- m) Successful bidder shall furnish detailed erection/installation manual for each of the equipment supplied under this contract as per the schedule of submission of documents and well before the scheduled erection of the equipment / component concerned.
- n) Document approval by customer under Approval category or information category shall not absolve the vendor of their contractual obligations of completing the work as per specification requirement. Any deviation from specified requirement shall be reported by the vendor in writing and shall require written approval. Unless any change in specified requirement has been brought out by the vendor during detail engineering in writing while submitting the document to customer for approval, approved document (with implicit deviation) will not be cited as a reason for not following the specification requirement.
- o) In case vendor submits revised drawing after approval of the corresponding drawing, any delay in approval of revised drawing shall be to vendor's account and shall not be used as a reason for extension in contract completion.

748363/2022/PS-PEM-MAX



3x800 MW PATRATU TPS

GYPSUM DEWATERING EQUIPMENT
TECHNICAL SPECIFICATION

PRE-BID CLARIFICATION SCHEDULE

SPECIFICATION No: PE-TS-434-571-A901

SECTION : III

ANNEXURE : 3

REV. 00

SHEET: 1 OF 1

PRE-BID CLARIFICATION SCHEDULE

S. NO.	SECTION/CLAUSE/PAGE NO.	STATEMENT OF THE REFERRED CLAUSE	CLARIFICATION REQUIRED

The bidder hereby clarifies that above mentioned are the only clarifications required on the technical specification for the subject package.

Signature: _____

Name: _____

Designation: _____

Company: _____

Date: _____

Company Seal

	3x800 MW PATRATU TPS GYPSUM DEWATERING EQUIPMENT TECHNICAL SPECIFICATION DEVIATION SCHEDULE	SPECIFICATION No: PE-TS-434-571-A901	
		SECTION : III	
		ANNEXURE : 4	
		REV. 00	
		SHEET 1 OF 1	

DEVIATION SHEET (COST OF WITHDRAWAL)

**(TO BE FILLED UP BY BIDDER IN THE FORMAT ATTACHED AS
ANNEXURE –II OF GENERAL CONDITIONS OF CONTRACT ISSUED
ALONG WITH TENDER. ANY DEVIATION QUOTED ELSEWHERE/ IN
OTHER FORMAT SHALL NOT BE CONSIDERED)**

	3x800 MW PATRATU TPS	SPECIFICATION No: PE-TS-434-571-A901	
	GYPSUM DEWATERING EQUIPMENT TECHNICAL SPECIFICATION	SECTION : III	
		ANNEXURE : 5	
		REV: 00	
SCHEDULE OF GUARANTEES	SHEET 1 OF 2		

SCHEDULE OF GUARANTEES

	3x800 MW PATRATU TPS	SPECIFICATION No: PE-TS-434-571-A901	
	GYPHUM DEWATERING EQUIPMENT TECHNICAL SPECIFICATION	SECTION : III	
		ANNEXURE : 5	
		REV: 00	
		SHEET 2 OF 2	
SCHEDULE OF GUARANTEES			

1.0 PERFORMANCE GUARANTEE

All performance tests for GDS shall be carried out in accordance with the relevant latest international codes/standards.

- 1) Bidder shall furnish Performance guarantee for the design, manufacture, material, safe and trouble-free operation of the complete Gypsum Dewatering Equipment (GDE) and its accessories.
- 2) Bidder shall furnish guaranteed power consumption for the gypsum dewatering equipment. Guaranteed Power Consumption in the applicable format shall be submitted as part of techno commercial offer as per the table provided in Annexure-IV of the price schedule.
- 3) Vendor shall Guarantee and demonstrate each Vacuum Belt Filter capacity of minimum 136 TPH wet gypsum cake with an inlet solid concentration of 45% by weight.
- 4) The contractor shall guarantee and demonstrate that gypsum cake moisture content shall not be more than 10% and chloride content shall not be more than 100 ppm.
- 5) The filter cloth shall be guaranteed for a minimum life of not less than 7000 hours.
- 6) The wear belt shall be guaranteed for a minimum life of not less than 7000 hours.
- 7) The liners in hydro-cyclone shall have a minimum wear life of not less than 7000 hrs.
- 8) Noise level ≤ 85 dB (A) at 1m horizontal distance from equipment/enclosures & 1.5m above operating floor is to be guaranteed.
- 9) Vibration levels measured on the non-rotating parts shall not exceed the zone limit "B" as defined in ISO 10816 at steady conditions and shall not exceed the zone limit "C" as defined in ISO 10816 at transient conditions.
- 10) Acceptance tests to be carried out as per the procedure defined by the bidder which shall be submitted for BHEL/ PVUNL approval.
- 11) In the event that the performance test is unsuccessful, bidder shall take necessary remedial action at his cost and the performance test shall be repeated.

Bidder is required to submit signed & stamped copy of this document.

	3x800 MW PATRATU TPS	SPECIFICATION No: PE-TS-434-571-A901	
	GYPSUM DEWATERING EQUIPMENT TECHNICAL SPECIFICATION	SECTION : III	
	EQUIPMENT DATA SHEET/SCHEDULE	ANNEXURE : 8	
		REV. 00	
		SHEET 1 OF 8	

EQUIPMENT DATA SHEET/SCHEDULE

S.No.	Description	Data
1.0	GENERAL	
	a. Client	: BHEL-PEM, Noida
	b. Project	: PVUNL Patratu 3x800 MW
	c. End Customer	: PVUNL/NTPC
	d. Location	: Ramgarh, Jharkhand
	e. Service	: Continuous
	f. Installation	: Inside the Building
	g. Quantity for all 3 FGD units	: 2 sets (1W+1S)
2.0	MANUFACTURER DETAILS	
	a. Model	: Bidder to Provide
	b. Type	: Bidder to Provide
3.0	OPERATING CONDITION	
	Medium to be handled	: Gypsum Slurry
4.0	Technical Data	
4.1	PRIMARY HYDRO-CYCLONE	
	i. Stage	Bidder to Provide
	ii. Manufacturer	Bidder to Provide
	iii. Number of Hydro cyclone	Bidder to Provide
	iv. Diameter of Hydro cyclone	Bidder to Provide
	v. Diameter of Vortex Finder	Bidder to Provide
	vi. Diameter of Apex Valve	Bidder to Provide
	vii. Diameter of Feed Inlet	Bidder to Provide
	viii. Design Pressure	Bidder to Provide
	ix. Working Pressure	Bidder to Provide
	x. Feed Flow rate	Bidder to Provide
	xi. Overflow Rate	Bidder to Provide
	xii. Underflow Rate	Bidder to Provide
	xiii. Mesh of separation (50% Removed)	Bidder to Provide

	3x800 MW PATRATU TPS	SPECIFICATION No: PE-TS-434-571-A901	
	GYPSUM DEWATERING EQUIPMENT TECHNICAL SPECIFICATION	SECTION : III	
		ANNEXURE : 8	
		REV. 00	
		SHEET 2 OF 8	
EQUIPMENT DATA SHEET/SCHEDULE			

	xiv. Solid content of feed slurry	Bidder to Provide
	xv. Solid content in underflow of Hydrocyclone	Bidder to Provide
	xvi. Solid content in Overflow of Hydrocyclone	Bidder to Provide
	xvii. Type of cyclone	Bidder to Provide
	a) Cyclone Dia/Height (mm)	Bidder to Provide
	b) Required Liquid Feed Pressure	Bidder to Provide
	c) Cyclone Connection Number/Dia. (mm)	Bidder to Provide
	d) Feed	Bidder to Provide
	e) Overflow	Bidder to Provide
	f) Underflow	Bidder to Provide
	g) Rf Value (Underflow Slurry (m ³ /hr/Feed	Bidder to Provide
	h) Material	Bidder to Provide
	i) Shell	Bidder to Provide
	j) Internal Structure Part	Bidder to Provide
	k) Lining	Bidder to Provide
	l) Particle Size Distribution	Bidder to Provide
	m) Weight	Bidder to Provide

4.2 VACUUM BELT FILTERS (VBF)

	a. Manufacturer	:	Bidder to Provide	
	b. Model No.	:	Bidder to Provide	
	c. Dimensions (W x L x H) (m x m x m)	:	Bidder to Provide	
	d. Cloth Width	m	:	Bidder to Provide
	e. Cloth Length	m	:	Bidder to Provide
	f. No. Working / Stand-by	:	Bidder to Provide	
	g. Capacity (Guaranteed) Gypsum (Dry)	Kg/hr	:	Bidder to Provide
	h. Inlet Flow Volume	m ³ /h	:	Bidder to Provide
	i. Gypsum Flow (Dry)	Kg/hr	:	Bidder to Provide

	3x800 MW PATRATU TPS	SPECIFICATION No: PE-TS-434-571-A901		
	GYPSUM DEWATERING EQUIPMENT TECHNICAL SPECIFICATION		SECTION : III	
			ANNEXURE : 8	
	EQUIPMENT DATA SHEET/SCHEDULE		REV. 00	
			SHEET 3 OF 8	

	j. Moisture Removed	%	:	Bidder to Provide
	k. No. of stages of cake washing / water flow	m3/h	:	Bidder to Provide
	l. No. of stages of cloth washing / water flow	m3/h	:	Bidder to Provide
	m. Design Pressure of Vacuum Chamber		:	Bidder to Provide
	n. Operating Pressure of Vacuum Chamber		:	Bidder to Provide
	o. Material / Thickness	mm	:	Bidder to Provide
	i. Casing		:	Bidder to Provide
	ii. Cloth		:	Bidder to Provide
	iii. Gypsum Discharge Hopper		:	Bidder to Provide
	iv. Vacuum Box		:	Bidder to Provide
	p. Life of Cloth	hrs	:	Bidder to Provide
	q. Type /Material of Carrying Belt		:	Bidder to Provide
	r. Type / Material of Sealing Belt		:	Bidder to Provide
	s. Life of Carrying Belt	hrs	:	Bidder to Provide
	t. Life of Sealing Belt	hrs	:	Bidder to Provide
	u. Automatic Cloth Tensioning Mechanism Provided		:	Yes / No - Bidder to confirm
4.3	VACUUM RECEIVER TANK			
	a. No. of Tank for each VBF		:	Bidder to Provide
	b. Capacity (m3)		:	Bidder to Provide
	c. Dimensions (Dia x Height) (mm x mm)		:	Bidder to Provide
	d. Material / Thickness (mm)		:	Bidder to Provide
	e. Lining Material / Thickness mm		:	Bidder to Provide
4.4	Vacuum Pumps			
	a. Manufacturer		:	Bidder to Provide
	b. Make/Model		:	
	c. Type		:	Bidder to Provide
	d. No. of Pumps for each Vacuum Belt Filter		:	Bidder to Provide
	e. Rated Capacity Flow (m ³ /hr)		:	Bidder to Provide

	3x800 MW PATRATU TPS	SPECIFICATION No: PE-TS-434-571-A901	
	GYPSUM DEWATERING EQUIPMENT	SECTION : III	
	TECHNICAL SPECIFICATION	ANNEXURE : 8	
	EQUIPMENT DATA SHEET/SCHEDULE	REV. 00	SHEET 4 OF 8

	Rated Capacity Head (mWCI)	:	Bidder to Provide
	Rated Capacity Power (KW)	:	Bidder to Provide
f.	Power consumption (KW)	:	Bidder to Provide
g.	Pump Speed (rpm)	:	Bidder to Provide
h.	Motor Rating (KW)	:	Bidder to Provide
i.	Motor Speed (rpm)	:	Bidder to Provide
j.	Margins (Flow/Head) (%/%)	:	Bidder to Provide
k.	Operation Pressure	:	Bidder to Provide
l.	Design Pressure	:	Bidder to Provide
m.	Material/Thickness (mm) of	:	Bidder to Provide
	Base/Lining	:	Bidder to Provide
	Casing	:	Bidder to Provide
	Shaft	:	Bidder to Provide
	Impeller	:	Bidder to Provide
n.	Type of seal	:	Bidder to Provide
o.	Sealing Water Flow (m3/hr)	:	Bidder to Provide
p.	Bearing	:	Bidder to Provide
	No. of Bearings	:	Bidder to Provide
	Type Of Bearings	:	Bidder to Provide
q.	Type of coupling	:	Bidder to Provide
r.	Whether silencer provided at outlet	:	Yes/No
4.5	SLURRY PIPES	:	
a.	Pipe size (mm)	:	Bidder to Provide
b.	Type of Joints	:	Bidder to Provide
	Pipe to Pipe/Pipe to Fittings	:	Bidder to Provide
	Fittings	:	Bidder to Provide
c.	Material / Thickness (mm)of Pipe	:	Bidder to Provide
d.	Material Thickness of lining	:	Bidder to Provide
e.	Estimated Life of liners (hrs.)	:	Bidder to Provide
f.	Slurry Solid concentration (w/w %)	:	Bidder to Provide

	3x800 MW PATRATU TPS	SPECIFICATION No: PE-TS-434-571-A901	
	GYPSUM DEWATERING EQUIPMENT TECHNICAL SPECIFICATION	SECTION : III	
	EQUIPMENT DATA SHEET/SCHEDULE	ANNEXURE : 8	
		REV. 00	
		SHEET 5 OF 8	

g.	Slurry Settling Velocity (m/s)		Bidder to Provide
h.	Pipe Velocity (m/s)		Bidder to Provide
4.6	BELT FILTER WASH PUMPS		
a.	No. for each VBF		
b.	No. of stand-by pumps for each VBF		
c.	Make / Model		
d.	Impeller Type		
e.	Material / Thickness (mm) of Impeller and lining		
f.	Casing Type		
g.	Material/Thickness of Casing/Lining		
h.	Rated Flow/Head (m ³ /hr./mWCI)		
4.7	CAKE WASH PUMPS		
i.	No. for each VBF		
j.	No. of stand-by pumps for each VBF		
k.	Make / Model		
l.	Impeller Type		
m.	Material / Thickness (mm) of Impeller and lining		
n.	Casing Type		
o.	Material/Thickness of Casing/Lining		
p.	Rated Flow/Head (m ³ /hr./mWCI)		
4.8	BELT ACCESSORIES		
4.8.	Bearing		
1			
a.	Carrying	:	Bidder to Provide
b.	Return	:	Bidder to Provide
4.8.	Material		
2			
a.	Roller	:	Bidder to Provide
b.	Spindle	:	Bidder to Provide
4.8.	Pulleys		
2			
i)	General (for all types of Pulleys)	:	Bidder to Provide
a.	Pulley Shaft Diameter	:	Bidder to Provide

	3x800 MW PATRATU TPS	SPECIFICATION No: PE-TS-434-571-A901	
	GYPSUM DEWATERING EQUIPMENT	SECTION : III	
	TECHNICAL SPECIFICATION	ANNEXURE : 8	
	EQUIPMENT DATA SHEET/SCHEDULE	REV. 00	
		SHEET 6 OF 8	

ii)	Drive Pulleys		
a.	Lagging	:	Bidder to Provide
b.	Lagging thickness	:	Bidder to Provide
c.	Minimum angle of wrap	:	Bidder to Provide
d.	Maximum out of roundness	:	Bidder to Provide
iii)	Other Pulleys		
a.	Lagging	:	Bidder to Provide
b.	Lagging thickness	:	Bidder to Provide
iv)	Rubber for lagging		
a.	Type	:	Bidder to Provide
b.	Hardness	:	Bidder to Provide
c.	Elongation	:	Bidder to Provide
d.	Strength	:	Bidder to Provide
e.	Abrasion Loss	:	Bidder to Provide
f.	Specific Gravity	:	Bidder to Provide
g.	Adhesion Strength	:	Bidder to Provide
v)	Bearings for Pulleys		
a.	Type	:	Bidder to Provide
b.	Casing	:	Bidder to Provide
c.	Sealing	:	Bidder to Provide
d.	Lubrication	:	Bidder to Provide
e.	Pulley Material	:	Bidder to Provide
f.	Shaft Material	:	Bidder to Provide
4.9	Chutes and Hoppers		
a.	Minimum Valley Angle	:	Bidder to Provide
b.	Material :	:	Bidder to Provide
	i) Chute work	:	Bidder to Provide
	ii) Sliding zones & adjacent sides	:	Bidder to Provide
	iii) No striking/ Non sliding zones	:	Bidder to Provide

	3x800 MW PATRATU TPS	SPECIFICATION No: PE-TS-434-571-A901	
	GYPHUM DEWATERING EQUIPMENT	SECTION : III	
	TECHNICAL SPECIFICATION	ANNEXURE : 8	
	EQUIPMENT DATA SHEET/SCHEDULE	REV. 00	SHEET 7 OF 8

	iv) Chute with valley angle 80 degree and above	:	Bidder to Provide
	v) In the zone of magnetic field	:	Bidder to Provide
	vi) In the zone of flap gates	:	Bidder to Provide
	vii) Discharge Hoods overhead pulleys	:	Bidder to Provide
c.	Inspection Doors	:	Bidder to Provide
d.	Chute Construction	:	Bidder to Provide
	i) Corners	:	Bidder to Provide
	ii) Joints Bolted	:	Bidder to Provide
	iii) Bolt size	:	Bidder to Provide
	iv) Bolts spacing	:	Bidder to Provide
	v) Fixing Arrangement	:	Bidder to Provide
4.9.	Skirt Boards		
a.	Length	:	Bidder to Provide
b.	Height	:	Bidder to Provide
c.	Width	:	Bidder to Provide
	<small>Side plate</small>		
4.9	Secondary (Waste Water) Hydrocyclone	:	Bidder to Provide
	i) Stage	:	Bidder to Provide
	ii) Manufacturer	:	Bidder to Provide
	iii) Number of Hydrocyclone	:	Bidder to Provide
	iv) Diameter of Hydrocyclone	:	Bidder to Provide
	v) Diameter of Vortex Finder	:	Bidder to Provide
	vi) Diameter of Apex Valve	:	Bidder to Provide
	vii) Diameter of Feed Inlet	:	Bidder to Provide
	viii) Design Pressure	:	Bidder to Provide
	ix) Working Pressure	:	Bidder to Provide
	x) Feed Flow rate	:	Bidder to Provide
	xi) Overflow Rate	:	Bidder to Provide
	xii) Underflow Rate	:	Bidder to Provide
	xiii) Mesh of separation (50% Removed)	:	Bidder to Provide
	xiv) Solid content of feed slurry	:	Bidder to Provide

	3x800 MW PATRATU TPS	SPECIFICATION No: PE-TS-434-571-A901	
	GYPSUM DEWATERING EQUIPMENT	SECTION : III	
	TECHNICAL SPECIFICATION	ANNEXURE : 8	
	EQUIPMENT DATA SHEET/SCHEDULE	REV. 00	SHEET 8 OF 8

	xv) Solid content in underflow of Hydro-cyclones	:	Bidder to Provide
	xvi) Solid content in Overflow of Hydro-cyclones	:	Bidder to Provide
	xvii) Type of cyclone	:	Bidder to Provide
	a. Cyclone Dia/Height (mm)	:	Bidder to Provide
	b. Required Liquid Feed Pressure	:	Bidder to Provide
	c. Cyclone Connection Number/Dia. (mm)	:	Bidder to Provide
	d. Feed	:	Bidder to Provide
	e. Overflow	:	Bidder to Provide
	f. Underflow	:	Bidder to Provide
	g. Rf Value (Underflow Slurry (m ³ /hr/Feed Slurry (m ³ /hr)	:	Bidder to Provide
	h. Material	:	Bidder to Provide
	i. Shell	:	Bidder to Provide
	j. Internal Structure Part	:	Bidder to Provide
	k. Lining	:	Bidder to Provide
	l. Particle Size Distribution	:	Bidder to Provide
	m. Weight	:	Bidder to Provide

Note:

The information as above and provided in the drawings/ datasheets shall be kept for information only. Any undeclared deviation therein shall stand null and void. This shall not be used for evaluation, unless specified. The same shall be submitted to BHEL's customer for the approval during the detail engineering/ execution stage. Explanations/ justifications shall be provided by bidder and the drawings/ documents shall be revised meeting contract specifications without any cost/ delivery implication to BHEL.

