



BHARAT HEAVY ELECTRICALS LTD.
 (A GOVT. OF INDIA UNDERTAKING)
 P.O BHEL Jhansi - 284129, INDIA
 Tel.:0510-277001/2412260 Fax: 2412120
 Email : mmx@bheljhs.co.in

PURCHASE ENQUIRY

ENQ NO/DT: E4229001 09/05/22
 REV NO/DT: 0 09/05/22

PAGE 1/6

PLEASE SEND YOUR BEST QUOTATION AS PER TERMS & CONDITIONS AND REMARK MENTIONED UNDERNEATH.

Enq Due on:	23-05-22 MONDAY
Close at:	13:15 Open at:14:00
Matcat:	421005 LAMINATION FOR POWER
Validity:	120 days from Technical bid opening date
IEM:	YES
TOP:	See Special Remarks
RA:	RA not applicable
Est. Value:	Item wise
Bid Type:	TWO BID
Tot Item:	1
Delivery:	FOR Jhansi
E-Proc:	Yes

REQUIRED: TEST CERT

ITEM NO : 1 PSL QTY/UM: 372.00 ST
 MATL CODE : TR171671N101 PO QTY /UM: 2000000.00 KG
 DESTINATION: JS

DESCRIPTION	DELIVERY	QUANTITY (PSL UM)
TRANSFORMER LAMINATIONS	JUL-22	75.00
TO GRADE 27H103 (MOH/27HP100/23HP100	AUG-22	75.00
AS PER CPS-BP10988 REV-04	NOV-22	75.00
AND TO OUR	DEC-22	75.00
TYPICAL CORE SHEET.	FEB-23	72.00

SPECIAL REMARKS:

- TENDER ENQUIRY IS BEING PUBLISHED IN TWO PART BIDDING ON NIC PORTAL (<https://eprocurebhel.co.in/>).
- PART "A" (COVER NAME - ****Pack1) SHOULD CONTAIN YOUR TECHNO - COMMERCIAL OFFER ALONGWITH OTHER COMMERCIAL DOCUMENTS.
- PART "B" (COVER NAME - ****Pack2) SHOULD CONTAIN PRICE BID ONLY.
- PLEASE SEND THE TECHNO-COMMERCIAL BID (PART A) & PRICE BID (PART-B) AS PER FORMATS UPLOADED ON NIC PORTAL ONLY BEFORE DUE DATE AND TIME SPECIFIED IN ENQUIRY.
- ALL THE TERMS AND CONDITIONS OF THE CONTRACT WITH RESPECT TO TAXES AND DUTIES ARE SUBJECT TO THE NEW TAXATION LAWS INTRODUCED FROM TIME TO TIME (E.G. GST). THE TERMS AND CONDITIONS WILL BE MODIFIED IN ACCORDANCE WITH THE PROVISIONS OF NEW LAWS E.G. GST.
- PREFERENCE TO PURCHASE UNDER 'MAKE IN INDIA' (MII) SHALL BE GIVEN AS PER CLAUSE 23 OF BHEL JHANSI GTC REV 03.
- RA SHALL NOT BE CONDUCTED. L-1 BIDDER WILL BE DECIDED BY PRICE BID OPENING OF TECHNICALLY ACCEPTED BIDDERS.
- LAMINATIONS WILL BE REQUIRED GENERALLY AS PER OUR TYPICAL CORE MENTIONED IN TENDER DOCUMENTS SCHEDULE-I.
- DRGS WILL BE SENT THROUGH EMAIL
- DELIVERY MENTION ABOVE IS INDICATIVE ONLY AND IS ONLY FOR OUR SYSTEM REQUIREMENT (YOU MAY IGNORE THE SAME) HOWEVER EXACT DELY WILL BE GIVEN IN THE INDIVIDUAL P.O. WHICH WILL BE RELEASED DURING THE PERIOD THROUGH WHICH THE RATE CONTRACT IS VALID. PLEASE QUOTE YOUR BEST DELIVERY SCHEDULE & MONTHLY CAPACITY IN SL. NO. 1 AND 3 OF THE GENERAL PART OF TECHNO COMMERCIAL BID. (SCHEDULE IV OF THE TENDER DOCUMENT)
- FRAMEWORK AGREEMENT AGAINST THIS ENQUIRY SHALL BE VALID FOR ORDERING FOR ONE YEAR FROM DATE OF AWARD OF CONTRACT (LAST DAY OF 12TH MONTH) AND FOR SUPPLY 3 MONTHS THEREAFTER OR CONTRACTUAL DELIVERY WHICHEVER LATER. THE CONTRACT CAN BE FURTHER EXTENDED FOR ONE MORE YEAR ON MUTUALLY AGREED BASIS.
- RATES CALLED ARE FOR FINISH LAMINATION AND PVC IS APPLICABLE AS PER



BHARAT HEAVY ELECTRICALS LTD.
(A GOVT. OF INDIA UNDERTAKING)
P.O BHEL Jhansi - 284129, INDIA
Tel.:0510-277001/2412260 Fax: 2412120
Email : mmx@bheljhs.co.in

PURCHASE ENQUIRY

ENQ NO/DT: E4229001 09/05/22
REV NO/DT: 0 09/05/22

PAGE 2
6

CLAUSE 9 OF SCHEDULE III OF TENDER DOCUMENT.KINDLY QUOTE YOU PRICES
KEEPING IN CONSIDERATION THE PVC CLAUSE.

11-QUANTITY MAY VARY BY +/-30% FOR EACH ITEM.

13-DUE TO LARGE QUANTITY & SMOOTH FLOW OF SUPPLY, FA MAY BE FINALISED
WITH MORE THAN 1 SOURCE LIMITED TO 3 SUPPLIERS IN LINE WITH
CLAUSE 8 OF SCHEDULE III OF TENDER DOCUMENTS.

THE QUOTATION MUST BE SEALED AND BE SENT IN DOUBLE ENVELOPE.
THE INNER ENVELOPE SHOULD BEAR ENQUIRY NUMBER & DUE DATE AT THE TOP.

In case the bidder has not submitted PAN No, TIN No. and E-mail ID, the bidder has to submit the same
along with the copy of PAN No and TIN No. Else his offer will be liable to be rejected.

If you are not in a position to quote due to any reason, you must send regret letter titled enquiry
no. etc, failing which you may not be considered for sending future enquiries.

ENCLOSERS:



JSC140/M2053

BHARAT HEAVY ELECTRICALS LTD.
(A GOVT. OF INDIA UNDERTAKING)
P.O BHEL Jhansi - 284129, INDIA
Tel.:0510-277001/2412260 Fax: 2412120
Email : mmx@bheljhs.co.in

PURCHASE ENQUIRY

ENQ NO/DT: E4229001 09/05/22
REV NO/DT: 0 09/05/22

PAGE 3
6

FOR AND ON BEHALF OF
BHARAT HEAVY ELECTRICALS LTD

M. Singh
9/5/22
CHOUHRY M S VERMA
MANAGER (CMM)
Email:-mulayam@bhel.in

***** END OF PURCHASE ENQUIRY*****

NOTE :

- * THE BIDDER IS INFORMED THAT THE GENERAL TERMS & CONDITIONS OF ENQUIRY (JHS 2055A Rev 03) WHICH ARE UPLOADED AT <https://www.bheljhs.co.in/apps/sip/index.php> AT (TERMS & CONDITION -> FOR ENQUIRY) LINK, ARE TO BE READ BY THE BIDDER BEFORE SUBMITTING QUOTE IN THE ENQUIRY. BHEL SHALL CONSTRUCT THE PARTICIPATION BY THE BIDDER IN ENQUIRY AS ACCEPTANCE TO THE GENERAL TERMS AND CONDITIONS OF ENQUIRY.
- * SUPPLIERS ARE REQUESTED TO INFORM US WITH VALID CERTIFICATE, IF THEY ARE REGISTERED UNDER MSMED ACT'2006. (APPLICABLE FOR INDIAN SUPPLIERS ONLY).
- * FOR SUPPLIERS SUPPLYING FROM OUTSIDE THE LOCAL AREA OF BHEL JHANSI, ENTRY TAX WILL BE APPLICABLE. SUPPLIERS SHOULD NECESSARILY INDICATE RATE OF ENTRY TAX SEPARATELY WHEREVER APPLICABLE. THEY SHOULD ALSO MENTION THE ENTRY TAX CHARGED SEPARATELY IN THE INVOICE.
- * FOR SUPPLIERS SUPPLYING FROM OUTSIDE UP, IN CASE THE OFFER IS SILENT ON ENTRY TAX, IT SHALL BE LOADED SUITABLY WITH THE APPLICABLE RATES
- * IN CASE IF THERE IS ANY DIFFERENCE BETWEEN THE 'SPECIAL REMARKS/ANNEXURES' OF THE ENQUIRY AND THE PREPRINTED TERMS & CONDITIONS (REF JSC140/M2053), THE REQUIREMENT GIVEN IN REMARKS WILL PREVAIL.
- * Reference Sl. No. 2(B) of General Terms and Conditions regarding option for offer submission through Email addressed to tenderbox.jhs@bhel.in , please note that the maximum mail size including attachments should not exceed 20 MB , otherwise the offer shall not be delivered due to size limitation and bidder sending mail attachments more than 20 MB will have no claim whatsoever on the subject tender . Also due to any technical snag , if offer has not reached tenderbox.jhs@bhel.in , it will be bidder's sole responsibility to ensure offer submission through alternate routes before the due date and time .BHEL will not entertain any such claim for non-receipt of offer on time .



Ref: E4229001

BHARAT HEAVY ELECTRICALS LIMITED

(A Govt. of India Undertaking)

MM (PURCHASE), JHANSI – 284120



Phone : 0510-2412716

Email: mulayam@bhel.in

For One Year Framework Agreement of 27H103 (MOH/27HP100/23HP100 GRADE CRGO Laminations to our typical core sheet

CONTENTS

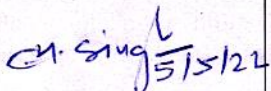
SL NO	Particulars	Schedule	Page Nos
1	Qualification Criteria and Quantities covered in this tender Enquiry	Schedule-I	02-04
2	Instructions for submission of Tender	Schedule-II	05-06
3	Techno-Commercial Terms & Conditions	Schedule-III	07-12
4	Techno-Commercial Bid	Schedule-IV	13-17
5	Blank Price Bid Format	Schedule-V	18
6	Integrity Pact	Schedule-VI	19-24

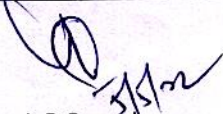
PREPARED BY.	CHECKED BY	APPROVED BY
 Ch. Mulayam Manager(CMM)	 Pawan Kumar DGM (CMM)	 A P Samal AGM (CMM-H)





BHARAT HEAVY ELECTRICALS LIMITED

(A Govt. of India Undertaking)

MM (PURCHASE), JHANSI – 284120

Phone : 0510-2412716

Email: mulayam@bhel.in

Ref: E4229001

3	<p>4. ABB Limited (Switzerland)/ ASTOR TRANSFORMER A.S (Turkey)/ Bemag Transformer, Inc. (Canada)/ Bowers Electricals Ltd. (UK)/ Changzhou XD Transformer Co., Ltd. (China)/ DAIHEN Corporation (Japan)/ EFACEC Group (Portugal)/ GE Grid Solutions (USA)/ Hammond Power Solutions, Inc. (Canada)/ Howard Industries, Inc. (USA)/ Hyosung Heavy Industries (South Korea)/ Hyundai Electric & Energy Systems Co., Ltd. (South Korea)/ Imefy Group (Spain)/ JSHP Transformer (China)/ KONCAR Group (Croatia)/ Mitsubishi Electric Corporation (Japan)/ Olsun Electrics Corporation (USA)/ Schneider Electric SA (France)/ SGB-SMIT Group (Germany)/ SGB-SMIT Power Matla (South Africa)/ Shihlin Electric & Engineering Corporation (Taiwan)/ Siemens AG (Germany)/ SPX Transformer Solutions, Inc. (USA)/ TBEA Co., Ltd. (China)/ Toshiba Energy Systems & Solutions Corporation (Japan)/ Wilson Power Solutions (UK)/ Wilson Transformer Company (Australia)/ Winder Power Ltd. (UK).</p>	<input type="checkbox"/> Yes <input type="checkbox"/> Yes																				
4	<p>Minimum Quantum- Should have supplied</p> <p>(a) for non-MSEs (1) Minimum 200,000Kg (or) (2) Goods of worth Rs 100 Lakhs.</p> <p>(b) For MSEs (1) Minimum 140, 000 Kg (or) (2) Goods of worth Rs 70 Lakhs</p> <p>Vendor to submit details of executed PO.</p> <table border="1" data-bbox="288 1010 1203 1312"> <thead> <tr> <th>Customer Name</th> <th>Order No. & Date</th> <th>Qty. supplied in UM</th> <th>Order, Tax Invoice No., TC No. & Date</th> <th>Remark, if any</th> </tr> </thead> <tbody> <tr><td> </td><td> </td><td> </td><td> </td><td> </td></tr> <tr><td> </td><td> </td><td> </td><td> </td><td> </td></tr> <tr><td> </td><td> </td><td> </td><td> </td><td> </td></tr> </tbody> </table>	Customer Name	Order No. & Date	Qty. supplied in UM	Order, Tax Invoice No., TC No. & Date	Remark, if any																
Customer Name	Order No. & Date	Qty. supplied in UM	Order, Tax Invoice No., TC No. & Date	Remark, if any																		
5	<p>It is better / desired that New vendors who are not registered with BHEL, Jhansi should submit duly filled "Supplier Registration Form (SRF)" along with the requested documents. The SRF is available on line on our website www.bhel.com. However the same is not mandatory.</p>	<input type="checkbox"/> Document Submitted																				

- We agree that our bid is liable to be rejected in case (a) the relevant information is not filled, (b) documentation is incomplete, (c) there are false declarations, and (d) if we do not meet the PQR.
- Supporting documents for the details filled above have been submitted.

33



Ref: E4229001

BHARAT HEAVY ELECTRICALS LIMITED

(A Govt. of India Undertaking)

MM (PURCHASE), JHANSI – 284120

Phone : 0510-2412716

Email: mulayam@bhel.in

Schedule- I

Quantities Covered: Quantity Covered in this tender enquiry are as follows:

Sl. No.	Description	Total Qty.(Approx.)
(A)	TRANSFORMER LAMINATIONS TO GRADE 27H103(MOH/27HP100/23HP100 AS PER CPS-BP10988 REV-04 AND TO OUR TYPICAL CORE SHEET.	372 SET 2000,000 kg (2000MT) +/- 30%

This requirement is tentative and may increase up to +30% depending upon BHEL's order book position and production requirement.

FA ordering shall be valid for One year from the date of entering into Rate Contract (last day of 12th months) and supply 03 months thereafter or contractual delivery whichever is later.



Signature

csingh



Ref: E4229001

BHARAT HEAVY ELECTRICALS LIMITED

(A Govt. of India Undertaking)

MM (PURCHASE), JHANSI – 284120

Phone : 0510-2412716

Email: mulayam@bhel.in

Schedule- II

INSTRUCTIONS FOR SUBMISSION OF TENDER

1. This Tender Enquiry is being published in two part bidding on BHEL NIC Portal (<https://eprocurebhel.co.in/>)
2. The offers against the enquiry shall be uploaded in two parts in corresponding covers as detail under.

Part – A Techno-commercial Bid (Cover Name – 2022_BHEL_***pack1):**

- Should contain Duly filled & signed Enquiry Document Page 2 to 34 along with any other technical/commercial document except 'Price Bid'.

Part – B Price Bid (Cover Name – 2022_BHEL_***pack2):**

- Should contain only Price bid duly filled in prescribed format.

3. Bidder shall submit Part - A & Part - B of their offers on BHEL NIC Portal only. Offers received in any other mode/medium shall be treated as 'UNSOLICITED TENDER'.
4. The bids shall be submitted only in the format given in the tender documents. It may be noted that each page of the tender document has been signed by BHEL. While submitting the bid, copy of these very pages are to be used. The tenderer is also required to sign and stamp each and every page of the tender document clearly bring out deviations, if any.
5. Part - A of the bid alone shall be opened online on BHEL NIC Portal on defined due date. This part of the bid shall be examined in detail. Part - B of the bid shall be opened only for such of the tenderers whose Techno-Commercial offers are found acceptable by BHEL. Such tenderers shall be notified the date and time of opening of Part - B i.e. price part of their bids.
6. Tenders not complying with the above and other requirements of the tender shall be liable for rejection. Tenderers are therefore advised to read all the documents carefully before submission of the bids and ensure the fulfillments of all the technical and commercial parameters. Tenderers must carefully go through all the instructions and conditions before filling in Part - B of the bid. Any type of mistake in submission of the bids will make the tenderer liable for rejection.
7. It must be clearly understood that the orders released against this tender enquiry shall be governed by the General terms & conditions of the contract as preprinted overleaf of the enquiry. No deviation from these conditions is permitted.
8. Corrections in the bid should normally be avoided. However, when these become essential, bidder shall score out the incorrect information and put the correct information duly endorsing each correction with his signatures.





Ref: E4229001

BHARAT HEAVY ELECTRICALS LIMITED

(A Govt. of India Undertaking)

MM (PURCHASE), JHANSI – 284120

Phone : 0510-2412716

Email: mulayam@bhel.in

Schedule- II

9. **Integrity Pact (IP)**

- (a) IP is a tool to ensure that activities and transaction between the company and its Bidders / contractors are handle in a fair, transparent and corruption free manner. Following Independent External Monitors (IEMs) on the present panel have been appointed by BHEL with approval of CVC to oversee implementation of IP in BHEL.

Details of IEM for this tender is furnish below:

	Name	Mail ID
1	Shri Arun Chandra Verma IPS (Retd.)	acverma1@gmail.com
2	Shri Virendra Bahadur Singh IPS (Retd.)	vbsinghips@gmail.com

- (b) The IP as enclosed with the tender is to be submitted (duly signed by authorized signatory who signs in the offer) along with techno- commercial bid. Only those bidders who have entered into such an IP with BHEL would be competent to participate in the bidding. In other word, entering into this pact would be a preliminary qualification.
- (c) Please refer section -8 of the IP for Role and responsibilities of IEMs. In case of any complaint arising out of the tendering process, the matter may be referred to any of the above IEM(s). All correspondence with the IEMs shall be done through email only.

Note:

No routine correspondence shall be addressed to the IEM (phone/ post/ email) regarding the clarifications, time extensions or any other administrative queries, etc on the tender issued. All such clarification/ issues shall be addressed directly to the tender issuing (procurement) department.

Tenders not complying with the above and other requirements of the tender shall be liable for rejection. Tenderers are therefore advised to read all the documents carefully before submission of the bids and ensure the fulfillments of all the technical and commercial parameters. Bidder shall be responsible for completion of the contract in all respects.

For clarification & support in submission of tender, the contact details are as follows:

Name and Contact Details of the Person for Queries in the Tender	Ch. Mulayam Manager/CMM, BHEL Jhansi Phone: - 0510-2412734 Email: - mulayam@bhel.in	Saurabh Kumar Addl. Engineering/CMM, BHEL Jhansi Phone: - 0510-2412716 Email: - saurabh.gupta@bhel.in
---	---	---

We confirm above instructions have been fully understood. We further confirm that price bid has been submitted without addition of any other terms & conditions and if the price bid is found to be conditional (e.g. minimum order quantity, slab rate, discount for quantity, different terms of payment etc. etc.), BHEL has full right not to accept our offer.

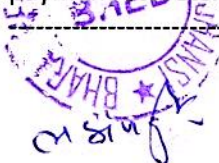



Ref: E4229001

BHARAT HEAVY ELECTRICALS LIMITED

(A Govt. of India Undertaking)

MM (PURCHASE), JHANSI – 284120

Phone : 0510-2412716

Email: mulayam@bhel.in

Schedule- III

TECHNO-COMMERCIAL TERMS & CONDITIONS

1. The Technical requirements for the laminations shall be as detailed at Schedule –I
2. In Price Bid format Part –B the rate should be quoted in Rs. per Kg on finish basis only for 27H103 (MOH/27HP100/23HP100 GRADE.
3. Rates shall be quoted duly considering the ITC credit available on the input material and the corresponding benefit on this account shall be passed on to BHEL. Taxes & Duties shall be extra as applicable on the date of actual delivery.
4. The rates quoted shall be on FOR BHEL Jhansi basis on Rs. per Kg on finish basis. **Packing, Forwarding, Freight & Insurance** from Bidder's works to BHEL Jhansi works shall be in the scope of the bidder.
5. **Packing:** Proper packing is to be done so that stack is not disturbed in transportation. Packing should be Limb wise. PO No/ WO No / Set No / Gross Wt. / Net Wt. should be mentioned in bold letter on each Case/ Box. While packing it should be ensured that there is no rusting on stack during storage and transportation. Application of blue lacquer may be ensured on all edges. **Material to be dispatched in returnable wooden/metal pallets.**

Synthetic QD Lacquer Blue as per specification enclosed must be applied on the edge of lamination (edge which is exposed to atmosphere after core assembly). Lacquer is not to be applied inside the core area due to it lying on the magnetic path

6. **Payment Terms :-**100 % payment within 90 days (45 days for MSE / NSIC registered suppliers as per relevant act in force) from the date of receipt of material and submission of clear and admissible bill, subject to acceptance of material at BHEL , on direct presentation of the documents. In case of despatch of material to site directly, site certification for receipt of materials is required unless otherwise provided for in the PO. Any deviation from the above payment terms, if accepted (by BHEL), shall be loaded @ SBI base rate (as on date of Part I bid opening) + 6%, for the purpose of bid evaluation. All documents as called for in the PO have to be submitted by the Supplier at the time of receipt of material and this should include the Invoice of the Supplier - Original copy of the Buyer and Duplicate for Transporter. On receipt of Invoice, the same shall be acknowledged by BHEL. Any clarifications on the bill submitted by the supplier shall be sought generally within 30 days (15 days for MSE / NSIC registered suppliers as per relevant act in force) of receipt of bill at BHEL. While it would be in the interest of the Supplier to provide the reply immediately to the clarifications sought, the Supplier is to respond at least within 7 days from the date of clarifications sought by BHEL. Wherever clarifications are sought by BHEL, the date of receipt of clarifications from the supplier shall be considered as date of submission of clear and admissible bill.
7. The validity of the quotation shall be for a period of minimum 120 days from the opening date of tender.





Ref: E4229001

BHARAT HEAVY ELECTRICALS LIMITED

(A Govt. of India Undertaking)

MM (PURCHASE), JHANSI – 284120

Phone : 0510-2412716

Email: mulayam@bhel.in

Schedule- III

8. **Manner of Splitting of rate Contract Quantity:** Due to large quantity requirement, we may finalize tendered quantities among more than one bidder (after acceptance of L1 price by the other bidders), but limited to capacity quoted by the bidder. Indicate your committed capacity for the items/ works/ services tendered and confirm that capacity offered by you against our tender shall be available for us during the entire period of Purchase Order/Contract.

Where the number of qualified responses (N) are three or more, the distribution shall be limited to (N-1) response. The manner and proportion of distribution shall be mentioned in the specific enquiry.

While the manner of distribution is mentioned in the enquiry, the absolute values of the unit of measurement shall be rounded off. For eg: If an allocation of 40% quantity results 23.5 units, the quantity allocated shall be 24 units. If an allocation of 40% quantity results in 23.3 units, the quantity allocated shall be 23 units.

The distribution shall be based on the acceptance given by the bidders to the L1 price counter offered to them. In case any or all of the bidders do not accept the counter offer, and a situation arises wherein bidder(s) who have agreed to the counter offer may have to be allotted more quantity than what has been proposed earlier, then the same shall be done, but limited to the capacity quoted by the bidder(s)“

Whenever, the number of techno commercially qualified responses (N) is two, BHEL reserves the right on whether or not to distribute the quantity on more than one bidder.

In this tender the quantities distribution shall be done between **THREE (03) bidders** as below stated ratio (%).

P (No of vendors)	L1	L2	L3	Total
1	100	NA	NA	100
2	70	30	NA	100
3	60	25	NA	100

Note: While the above patterns shall also be followed in long terms framework agreements (FA), performance of suppliers shall be monitored periodically, and loading in FA will also be subject to factors like (a) Customer approval of suppliers in specific projects, (b) quality surveillance at Supplier works, (c) Suppliers delivery and quality performance during execution of FA, (d) Pendency of orders on the supplier and (e) responsiveness in addressing post order completion issue at BHEL.

In view of above factors, the loading during execution of FA may vary with respect to allocated quantity. During execution of FA, if the performance of supplier is not upto the mark in respect of delivery/ quality performance/ quoted capacity of the bidder, BHEL reserve the right to either reduce further loading or stop loading till the execution of overdue orders. In such cases, action shall be taken against defaulting supplier(s) as per guidelines of the Company, and the balance allocated full or part quantity of defaulting supplier(s) may be redistributed amongst other performing and willing vendors of FA.

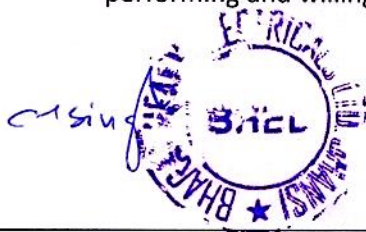



Ref: E4229001

BHARAT HEAVY ELECTRICALS LIMITED

(A Govt. of India Undertaking)

MM (PURCHASE), JHANSI – 284120

Phone : 0510-2412716

Email: mulayam@bhel.in

Schedule- III

9. PVC Clause :

Price variation is allowed on domestic supply offer for exchange rate only as per formula below :

$$P1 = P0 \times \{0.15 + 0.85 \times (ES/ET)\}$$

Where in

P1 is rate payable per kg.

P0 is quoted rate per kg.

ET and ES are Custom notified exchange rate in Rs. / US \$ prevalent on part-I technical bid opening date and one month prior to date of supply (LR date) respectively.

If delivery is made beyond the contractual delivery date, the ES will be Custom notified exchange rate in Rs. / US \$ prevalent one month prior to contractual delivery date or actual delivery date whichever is lower.

For example, if finished and stacked laminations are supplied on 15th March 2022 & PO delivery is 15th Feb 2022, custom notified exchange rate in Rs. / US \$ on 15th Feb 2022 or 15th Jan 2022, whichever is lower shall be taken for PVC Claim.

10. Framework agreement shall be valid for ordering for 01 Year (last day of 12th month) from date of award of contract and for supply 3 months or contractual delivery whichever is later.
11. **Supply conditions:** Laminations are to be cut on CNC cropping line only. CRGO laminations are to be made as per BHEL drawing provided for each purchase order. Number of sheets specified per stack per width should be ensured. Stack height is very important and to be maintained, weight may vary. Clarification should be immediately taken from Transformer Engineering division of BHEL Jhansi, if stack height is not achieved. Tolerance of $\pm 3\%$ per PO will be permissible to achieve required stack height and completeness of laminations. If total weight of laminations required exceeds PO quantity with permissible tolerance, prior approval shall be obtained from Transformer Engineering. All the limbs, center leg, side leg, yoke and fishes shall be supplied duly stacked in ready to build to core condition. Clarification, if any, to be taken from TRM/ TRE, BHEL Jhansi.
12. **Inspection and Test certificates:**
- a. Supplier shall submit Mill TC of raw material CRGO coils along with commercial documents (Bill of lading, Bill of entry, commercial invoice and packing list) in its name evidencing purchase of genuine CRGO coils for BHEL's lamination job for each purchase order within 7 working days of receipt of purchase order. Mill TC shall be submitted before processing job for approval / inspection from BHEL QC to avoid any quality complaints in future.
- b. BHEL Quality/Customer/TPIA will review TC or inspect coil at vendor works and accord clearance for processing laminations within 10 days (considering inspection duration and testing of samples at competent accredited testing lab as per ISO 17025. Certificate shall contain accreditation & ILAC logo) of submission of complete mill TC, clarifications and other documents if required any. Mill TC shall be as per BHEL specifications. No delivery extension request will be considered in case of delay by supplier in submission of complete documents and clarifications. BHEL will not be responsible for LD penalty due to delay in submission of mill TC or clarifications by vendor.

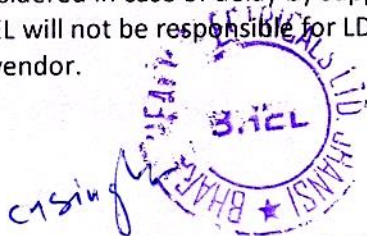

27



Ref: E4229001

BHARAT HEAVY ELECTRICALS LIMITED

(A Govt. of India Undertaking)

MM (PURCHASE), JHANSI – 284120

Phone : 0510-2412716

Email: mulayam@bhel.in

Schedule- III

- c. Test certificates should cover result of tests for mechanical and electrical properties as per specification for each coil No/ Heat No. All testing requirement as called for in the purchase specification specified in Purchase order must be part of the Mill TC to be issued by the Mill along with the supply.
- d. Dimensions and tolerances shall be as per specifications and a clause confirming same shall be mentioned clearly in mill TC submitted. Waviness test results shall also be mentioned in mill TC explicitly.
- e. Mill TC shall state bend test results (number of bends) and type test-ageing loss value. Separate certificate for type test-ageing loss issued by mill may be considered for contract validity period.
- f. BHEL reserves the right to get the material source inspected through its own Engineers / Customer/ Third party inspection agency. Inspection is to be done before (of prime CRGO coils) and after processing (of finished laminations). Supplier shall give inspection call at least 10 days in advance for both.
- g. **Raw material and finished laminations testing are in supplier's scope wherever required as per Quality Plan.**

13. Tests and procedure: Coils used for making laminations shall be tested for following -

- a. Maximum specific total loss and magnetic permeability measurement using Epstein or Single Sheet testing (for domain refined). Samples of raw material CRGO coils shall be provided to BHEL for internal testing. Sample of the Domain Refined Grade of CRGO will be tested on the Single Sheet Tester (SST). Total specific core loss measured by SST should be less than the maximum value specified in the corresponding specification. Results obtained at BHEL lab will be final and binding for acceptance of material.
- b. Electrical tests of surface insulation resistivity as per IS 649 Section-2
- c. Mechanical tests of ductility (bend test) and stacking factor.
- d. Type tests (ageing) to be carried out by supplier when "Type approval" and repeated at least once in every two years' period.

14. Test certificates: Test certificate shall clearly indicate following information:

- a. BHEL Purchase order.
- b. BHEL specification, Supplier's name, Grade, Identification no., Size and weight, Packet/ Bundle no.
- c. Test results of dimensions and tolerances
- d. Details of insulation coating
- e. Type test as required
- f. Properties of Specific total loss of each coil, Mechanical and Electrical properties for one random coil of each lot.

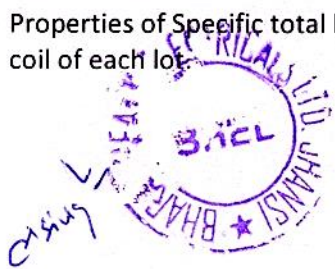



Ref: E4229001

26

BHARAT HEAVY ELECTRICALS LIMITED

(A Govt. of India Undertaking)

MM (PURCHASE), JHANSI – 284120

Phone : 0510-2412716

Email: mulayam@bhel.in

Schedule- III

g. Results of chemical composition (for information only)

1. Supplier shall enclose one copy of test certificate as per above along with dispatch documents to facilitate clearance/ acceptance of finished laminations. After making core with supplied laminations the core losses shall be measured at BHEL Bhopal/Jhansi. It will be reviewed with respect to the Test certificates of raw material / lamination provided by Supplier.
2. Supplier shall be responsible for higher losses if any. In case of higher losses, BHEL reserves the right to reject full lot.

15. Bharat Heavy Electricals Ltd does not bind itself to accept the lowest of any tender, but reserves to itself, the right to accept or reject all or a part of any tender at its discretion following BHEL purchase policy & Government guidelines.
16. In all cases of disputes, the matter shall be referred for arbitration. The arbitrator shall be nominated by the Unit Head, Bharat Heavy Electricals Ltd. Jhansi or any other officer nominated by him. The award of Arbitrator shall be final and binding on both the parties.
17. In case of any suit or other legal proceedings under or relating to this tender, the Courts at Jhansi shall have full jurisdiction.
18. **Penalty Clause:** If the material is not supplied within the stipulated time schedule, BHEL shall be within their right be free to cancel the contract and purchase the material through any other source at the risk and cost of the Bidder. In such an event it shall be obligatory on the defaulting Bidder to make good the loss suffered by BHEL. The above option shall be executed at the discretion of BHEL.
19. **LD Clause:** Failure to supply by the time specified on the purchase order will make the Bidder liable to pay unconditional penalty of ½% of the prices of goods in arrear per week subject to a maximum of 10% of the delayed order value unless mutually agreed otherwise.
20. **Guarantee Clause:** All goods shall be free from any defects due to faulty material and workmanship and it will be guaranteed for a period of 24 months from the date of dispatch & 18 months from the date of acceptance of material at BHEL Jhansi works, whichever is later.
21. The bidder is informed that the General Terms & Conditions of Enquiry which are uploaded at https://jhs.bhel.com/apps/sip/eng_terms/eng_tems_current.pdf are to be read by the bidder before submitting quote in the Enquiry. BHEL shall construe the participation by the bidder in the enquiry as acceptance to the General Terms & Conditions of Enquiry.



25



Ref: E4229001

BHARAT HEAVY ELECTRICALS LIMITED

(A Govt. of India Undertaking)

MM (PURCHASE), JHANSI – 284120

Phone : 0510-2412716

Email: mulayam@bhel.in

Schedule- III

22. Compliance to MAKE IN INDIA circular issued by Gov: "For this procurement, Public Procurement (Preference to Make in India), Order 2017 dated 15.06.2017, 28.05.2018, 29.5.2019 & 04.06.2020 and subsequent Orders issued by the respective Nodal Ministry shall be applicable even if issued after issue of this NIT but before finalization of contract/ PO/ WO against this NIT.

In the event of any Nodal Ministry prescribing higher or lower percentage of purchase preference and/ or local content in respect of this procurement, same shall be applicable "

To avail purchase preference under Make In India guidelines, vendor should be categorized as Class 1/Class 2 supplier. For a vendor to be classified as "Class 1 local supplier"/" Class 2 local supplier", bidder from which support letter has been furnished shall have to submit annexure – MII with seal and sign duly ratified / verified by statutory auditor or cost auditor of the company (in case of companies) or from a practicing chartered accountant (in respect of suppliers other than companies) giving the percentage of local content.





Ref: E4229001

BHARAT HEAVY ELECTRICALS LIMITED

(A Govt. of India Undertaking)

MM (PURCHASE), JHANSI – 284120

Phone : 0510-2412716

Email: mulayam@bhel.in

Schedule- IV

TECHNO COMMERCIAL BID (PART-A)

(Supplier should fill up this bid by putting the tick in accepted / not- accepted column)

SUPPLIER'S NAME & ADDRESS:-

.....

Ref No:

Date:.....

General

Sl.No.	Terms & Conditions	Remarks
1 (A)	Supply rate capacity for this tender MT per month
1 (b)	Quoted Quantity for tender (+/- 30 variation is applicable based on BHEL's requirement)MT (100% qty)
2	GST as applicable %
3	Commencement of Delivery Period from date of purchase order / LOI. (BHEL's desired delivery 2 month week from PO/LOI date) in months

COMMERCIAL PART.

Sl. No.	Terms & Conditions	Remarks
1	The supply of CRGO laminations as per Schedule - I. Packing is to be done "Ready to Built Core Condition".	Accepted / Not accepted
2	Rate is to be quoted on Rs. per Kg basis and fully finish basis.	Accepted / Not accepted
4	Rates quoted in the price bid are on CIP/FOR BHEL Jhansi basis.	Accepted / Not accepted
5	<p>PVC : Price variation is allowed on domestic supply offer for exchange rate only as per formula below :</p> <div style="border: 1px solid black; padding: 5px; display: inline-block; margin: 10px 0;"> $P1 = P0 \times \{0.15 + 0.85 \times (ES/ET)\}$ </div> <p>Where in P1 is rate payable per kg. P0 is quoted rate per kg. ET and ES are Custom notified exchange rate in Rs. / US \$ prevalent on part-I technical bid opening date and one month prior to date of supply (LR date) respectively. If delivery is made beyond the contractual delivery date, the ES will be Custom notified exchange rate in Rs. / US \$ prevalent one month prior to contractual delivery or actual delivery whichever is lower.</p>	Accepted / Not accepted

Handwritten signature

**BHARAT HEAVY ELECTRICALS LIMITED****(A Govt. of India Undertaking)**

MM (PURCHASE), JHANSI – 284120

Phone : 0510-2412716

Email: mulayam@bhel.in

Ref: E4229001

6	Taxes and duties shall be extra as applicable on the date of actual delivery.	Accepted / Not accepted
7	Validity of the rate quoted is 120 days from the date of opening of the tender.	Accepted / Not accepted
8	Penalty Clause :- If the material is not supplied within the stipulated time schedule as per the quoted delivery period as at Sl. No. 5 of General terms & condition, BHEL shall within their right be free to cancel the contract and purchase the material through any other source at the risk and cost of the supplier. In such an event it shall be obligatory on the defaulting supplier to make good the loss suffered by BHEL. The above option shall be executed at the discretion of BHEL.	Accepted / Not accepted
9	LD Clause:- Failure to supply by the time specified as per the quoted delivery period will make the supplier liable to pay unconditional penalty of ½% of the prices of goods in arrear per week or part thereof subject to a maximum of 10% of the delayed order value unless mutually agreed otherwise. Refer Sl. no. 8 of General terms & condition (GTC Rev 03)	Accepted / Not accepted
10	Payment Terms: -100 % payment within 90 days (45 days for MSE / NSIC registered suppliers as per relevant act in force) from the date of receipt of material and submission of clear and admissible bill, subject to acceptance of material at BHEL, on direct presentation of the documents and other terms & condition given in this tender are acceptable to us as per clause 6 of schedule –III.	Accepted / Not Accepted
11	Guarantee Clause :- All goods shall be free from any defects due to faulty material and workmanship and it will be guaranteed for a period of 24 months from the date of dispatch & 18 months from the date of acceptance of material at BHEL Jhansi works, whichever is later.	Accepted / Not Accepted
12	Manner of Splitting of rate Contract Quantity: The rate contract may be finalized with more than one vendor. However, allocation of rate contract quantity will be in decreasing order (max quantity to the lowest bidder L1, then to L2 considering their capacity & delivery / production requirement of BHEL. The rate contract will be established between Three(03) suppliers. The distribution of FA quantity shall be as at Clause 8 of Schedule III.	Accepted / Not Accepted
13	The L1 rate will be counter offered in sequence to L2, L3, & L4,.....(low to high).....for acceptance till a total of required	Accepted / Not Accepted

Original

**BHARAT HEAVY ELECTRICALS LIMITED****(A Govt. of India Undertaking)**

MM (PURCHASE), JHANSI – 284120

Phone : 0510-2412716

Email: mulayam@bhel.in

Ref: E4229001

	vendors are available for finalization of rate contract at L1 negotiated rate.	
14	BHEL specific or customer specific quality plan shall also be followed (if any).	Accepted / Not Accepted
15	<p>CRGO laminations are to be made from CRGO steel (mother coil) grade as per BHEL specifications specified in individual enquiry/ Purchase orders. Raw material – CRGO coils is to be procured from BHEL's Customer Approved Sources as listed below:</p> <ul style="list-style-type: none">a. M/s Nippon Steel & Sumitomo Metal Corp., Japanb. M/s JFE Steel Corporation, Japanc. M/s Posco, Koread. M/s A K Steel, USAe. M/s Viz Steel , Russiaf. M/s TKES, Germanyg. M/s TKES, India, Nashik <p>In addition to above, lamination processors can source CRGO coils from mills (except from the mills located in countries sharing geographical border with India) who have valid BIS license of grade of CRGO and are approved by at least one major customer of BHEL – PGCIL or NTPC or NPCIL.</p>	Accepted / Not Accepted
16	Please confirm material availability of the required Grade from the original manufacturer of the raw material as per clause no.15 as above.	Confirm / Not Confirm
17	One set of ink signed test certificate for laminations as well as CRGO rolls used in the manufacturing must be sent directly to the officials who has issued the Purchase Order along with other shipping documents immediately after shipment of material in case of order.	Accepted / Not Accepted
18	The test certificates for the CRGO raw material provided by the vendor shall not be of a purchase lot / consignment which is older than 12 months as on the date of inspection.	Accepted / Not Accepted
19	Vendor has to confirm that against the Purchase Orders placed by BHEL, the test certificate for the CRGO raw material should have proper correlation and traceability with the cut core laminations of the purchase order. This correlation shall be the vendor's responsibility at the time of inspection at their works.	Accepted / Not Accepted
21	Dimensin,tolerances and Burr level of finish laminations to be maintained as per drg. no.-TR10141C	Accepted / Not Accepted
22	During dispatch the Material to be supplied on sturdy wooden pallets duly stacked in "READY TO BUILT CORE" condition. Packing, covering and banding of the lamination stacks shall be suitable to	Accepted / Not Accepted

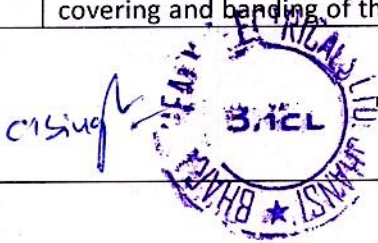

2



BHARAT HEAVY ELECTRICALS LIMITED

(A Govt. of India Undertaking)

MM (PURCHASE), JHANSI – 284120

Phone : 0510-2412716

Email: mulayam@bhel.in

Ref: E4229001

	prevent ingress of dust and moisture as well as to avoid slippage / damage of the core laminations during transit & handling.	
23	In this R/C some of the laminations may be required for PGCIL / NTPC project. In such case orders will be given to the approved vendors of PGCIL / NTPC / Railway etc as the case may be.	Accepted / Not Accepted
24	Material is to be source inspected at the vendor's works by BHEL appointed third party inspection Agency or BHEL representative or customer representative for which one week advance intimation shall be given by the supplier. <u>However, the final inspection for acceptance of quality and quantity shall be done at BHEL Jhansi works and incase of rejection, the material have to be replaced free of cost.</u>	Accepted / Not Accepted
25	Inspection will be carried out as per above remarks no. 24 at supplier's works before, during and after slitting / cropping operations. Verification of purchase documents (INVOICE, BILLING OF LADING) & correlated Test Certificates for CRGO prime rolls will be carried out before the slitting operations	Accepted / Not Accepted
26	While procuring raw material from above mills ' BIS ' certification of CRGO Ministry of Steel (Govt. of India) order of October 2013 regarding mandatory ' BIS ' certification of CRGO may be kept in view.	Accepted / Not Accepted
27	L1 bidder will be decided on FOR JHANSI BASIS.	Accepted / Not Accepted
28	L-1 bidder will be decided after price bid opening only. RA will not done.	Accepted / Not Accepted
29	The bidder is informed that the General Terms & Conditions of Enquiry which are uploaded at https://jhs.bhel.com/apps/sip/eng_terms/eng_tems_current.pdf are to be read by the bidder before submitting quote in the Enquiry. BHEL shall construe the participation by the bidder in the enquiry as acceptance to the General Terms & Conditions of Enquiry	Accepted / Not Accepted
30	Framework agreement against this enquiry shall be valid for ordering for one year from date of award of contract (last days of 12 th month) and supply 3 months thereafter or contractual delivery whichever is later. The contract can be further extended for one more year on mutually agreed basis.	Accepted / Not Accepted
31	All other terms & conditions of the printed document R/C enquiry are also acceptable to the vendors.	Accepted / Not Accepted
32.	Acceptance to MAKE IN INDIA clause no. 11 of schedule III	Accepted / Not Accepted

Handwritten signature: *msingh*

Handwritten initials: *MS*

Stamp: **BHARAT HEAVY ELECTRICALS LIMITED, JHANSI**



Ref: E4229001

BHARAT HEAVY ELECTRICALS LIMITED

(A Govt. of India Undertaking)

MM (PURCHASE), JHANSI - 284120

Phone : 0510-2412716

Email: mulayam@bhel.in

Note: If any of the above conditions are not accepted the offer shall be liable for rejection.

1. Person to be contacted :
2. Telephone No :
3. E mail Id :

Signature of Bidder :

Name :

Designation :

Seal :



19



Ref: E4229001

BHARAT HEAVY ELECTRICALS LIMITED

(A Govt. of India Undertaking)
MM (PURCHASE), JHANSI – 284120

Phone : 0510-2412716
Email: mulayam@bhel.in

Schedule- V

PRICE BID (PART - B)

(For reference only. To be filled format available online @ <https://eprocurebhel.co.in/>)

To,
DGM (MM)
BHEL JHANSI-284120 UP

Subject: - Price Bid against your annual Rate Contract Enquiry no. E4229001 for CRGO Lamination as per Enquiry specification.

Total landed cost exclusive Input tax credit for CRGO laminations as given below:

Sl.No.	Description	Enquiry #01
(A)-	BASIC RATE	
(B)-	GST	
(C)-	Input Tax Credit (same as B)	
(H)-	TOTAL LANDED COST (A + B – C) per Kg. This value to be quoted during reverse auction	In figure
		In words

NOTE :

- Please quote the price taking in consideration the PVC clause mentioned at clause 9 of schedule III
- The price bid submitted in any other fashion or by adding any condition (e.g. minimum order quantity, rates applicable for specified quantity, discount for quantity, rate based on slabs, rate based on terms of payment etc.), offer shall be liable to be REJECTED even if, offer has been found technically & commercial acceptable before opening of price bid.

Signature of Bidder's :

Name :

Designation :

Seal :





Ref: E4229001

BHARAT HEAVY ELECTRICALS LIMITED

(A Govt. of India Undertaking)

MM (PURCHASE), JHANSI – 284120

Phone : 0510-2412716

Email: mulayam@bhel.in

Schedule - VI

BHEL AA:MM:IP:R01 dtd 1.4.2010

INTEGRITY PACT

Between

Bharat Heavy Electricals Ltd. (BHEL), a company registered under the Companies Act 1956 and having its registered office at "BHEL House", Siri Fort, New Delhi - 110049 (India) hereinafter referred to as The Principal", which expression unless repugnant to the context or meaning hereof shall include its successors or assigns of the ONE PART

And

(description of the party along with address)

....., hereinafter referred to as The Bidder/ Contractor" which expression unless repugnant to the context or meaning hereof shall include its successors or assigns of the OTHER PART'

Preamble

The Principal intends to award, under laid-down organizational procedures, contract/s for supply of C.R.G.O. Lamination on finished basis. The Principal values full compliance with all relevant laws of the land, rules and regulations, and the principles of economic use of resources, and of fairness and transparency in its relations with its Bidder(s)/ Contractor(s).

In order to achieve these goals, the Principal will appoint independent External Monitor(s), who will monitor the tender process and the execution of the contract for compliance with the principles mentioned above.

Section 1- Commitments of the Principal

- 1.1 The Principal commits itself to take all measures necessary to prevent corruption and to observe the following principles :-
 - 1.1.1 No employee of the Principal, personally or through family members, will in connection with the tender for, or the execution of a contract, demand, take a promise for or accept, for self or third person, any material or immaterial benefit which the person is not legally entitled to.
 - 1.1.2 The Principal will, during the tender process treat all Bidder(s) with equity and reason. The Principal will in particular, before and during the tender process, provide to all Bidder(s) the same information and will not provide to any Bidder(s) confidential / additional information through which the Bidder(s) could obtain an advantage in relation to the tender process or the contract execution.
 - 1.1.3 The Principal will exclude from the process all known prejudiced persons.
- 1.2 If the Principal obtains information on the conduct of any of its employees which is a penal offence under the Indian Penal Code 1860 and Prevention of Corruption Act 1988 or any other statutory penal enactment, or if there be a substantive suspicion in this regard, the Principal will inform its Vigilance Office and in addition can initiate disciplinary actions.

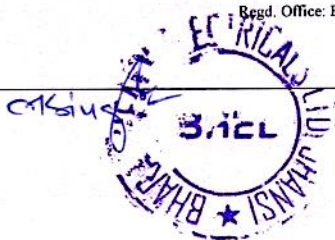



Ref: E4229001

BHARAT HEAVY ELECTRICALS LIMITED

(A Govt. of India Undertaking)

MM (PURCHASE), JHANSI – 284120

Phone : 0510-2412716

Email: mulayam@bhel.in

Schedule - VI

Section 2 - Commitments of the Bidder(s)/ Contractor(s)

- 2.1 The Bidder(s)/ Contractor(s) commit himself to take all measures necessary to prevent corruption. He commits himself to observe the following principles during his participation in the tender process and during the contract execution.
- 2.1.1 The Bidder(s)/ Contractor(s) will not, directly or through any other person or firm, offer, promise or give to the Principal or to any of the Principal's employees involved in the tender process or the execution of the contract or to any third person any material, immaterial or any other benefit which he / she is not legally entitled to, in order to obtain in exchange any advantage of any kind whatsoever during the tender process or during the execution of the contract.
- 2.1.2 The Bidder(s)/ Contractor(s) will not enter with other Bidder(s) into any illegal or undisclosed agreement or understanding, whether formal or informal. This applies in particular to prices, specifications, certifications, subsidiary contracts, submission or non-submission of bids or any other actions to restrict competitiveness or to introduce cartelization in the bidding process.
- 2.1.3 The Bidder(s)/ Contractor(s) will not commit any penal offence under the relevant IPC / PC Act; further the Bidder(s)/ Contractor(s) will not use improperly, for purposes of competition or personal gain, or pass on to others, any information or document provided by the Principal as part of the business relationship, regarding plans, technical proposals and business details, including information contained or transmitted electronically.
- 2.1.4 The Bidder(s)/ Contractor(s) will, when presenting his bid, disclose any and all payments he has made, and is committed to or intends to make to agents, brokers or any other intermediaries in connection with the award of the contract.
- 2.2 The Bidder(s)/ Contractor(s) will not instigate third persons to commit offences outlined above or be an accessory to such offences.

Section 3 - Disqualification from tender process and exclusion from future contracts

If the Bidder(s)/ Contractor(s), before award or during execution has committed a transgression through a violation of Section 2 above, or acts in any other manner such as to put his reliability or credibility in question, the Principal is entitled to disqualify the Bidder(s)/ Contractor(s) from the tender process or take action as per the separate "Guidelines on Banning of Business dealings with Suppliers/ Contractors". framed by the Principal.

Section 4 - Compensation for Damages

- 4.1 If the Principal has disqualified the Bidder from the tender process prior to the award according to Section 3, the Principal is entitled to demand and recover the damages equivalent Earnest Money Deposit/Bid Security.
- 4.2 If the Principal has terminated the contract according to Section 3, or if the Principal is entitled to terminate the contract according to section 3, the Principal shall be entitled to demand and recover from the Contractor liquidated damages equivalent to 5% of the contract value or the amount equivalent to Security Deposit/Performance Bank Guarantee, whichever is higher.

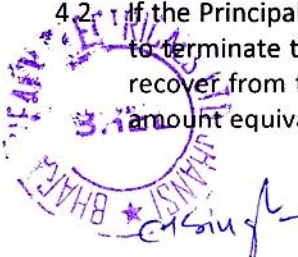



Ref: E4229001

BHARAT HEAVY ELECTRICALS LIMITED

(A Govt. of India Undertaking)

MM (PURCHASE), JHANSI – 284120

Phone : 0510-2412716

Email: mulayam@bhel.in

Schedule - VI

Section 5 - Previous Transgression

- 5.1 The Bidder declares that no previous transgressions occurred in the last 3 years with any other company in any country conforming to the anti-corruption approach or with any other Public Sector Enterprise in India that could justify his exclusion from the tender process.
- 5.2 If the Bidder makes incorrect statement on this subject, he can be disqualified from the tender process or the contract, if already awarded, can be terminated for such reason.

Section 6 - Equal treatment of all Bidders / Contractors / Sub - contractors

- 6.1 The Bidder(s)/ Contractor(s) undertake(s) to obtain from all subcontractors a commitment consistent with this Integrity Pact and report Compliance to the Principal. This commitment shall be taken only from those sub-contractors whose contract value is more than 20 % of Bidder's/ Contractor's contract value with the Principal. The Bidder(s)/ Contractor(s) shall continue to remain responsible for any default by his Sub-contractor(s).
- 6.2 The Principal will enter into agreements with identical conditions as this one with all Bidders and Contractors.
- 6.3 The Principal will disqualify from the tender process all bidders who do not sign this pact or violate its provisions.

Section 7 - Criminal Charges against violating Bidders/ Contractors / Subcontractors

If the Principal obtains knowledge of conduct of a Bidder, Contractor or Subcontractor, or of an employee or a representative or an associate of a Bidder, Contractor or Subcontractor which constitutes corruption, or if the Principal has substantive suspicion in this regard, the Principal will inform the Vigilance Office.

Section 8 -Independent External Monitor(s)

- 8.1 The Principal appoints competent and credible Independent External Monitor for this Pact. The task of the Monitor is to review independently and objectively, whether and to what extent the parties comply with the obligations under this agreement.
- 8.2 The Monitor is not subject to instructions by the representatives of the parties and performs his functions neutrally and independently. He reports to the CMD, BHEL.
- 8.3 The Bidder(s)/ Contractor(s) accepts that the Monitor has the right to access without restriction to all contract documentation of the Principal including that provided by the Bidder(s)/ Contractor(s). The Bidder(s)/ Contractor(s) will grant the monitor, upon his request and demonstration of a valid interest, unrestricted and unconditional access to his contract documentation. The same is applicable to Sub-contractor(s). The Monitor is under contractual obligation to treat the information and documents of the Bidder(s)/ Contractor(s) / Sub-contractor(s) with confidentiality,
- 8.4 The Principal will provide to the Monitor sufficient information about all meetings among the parties related to the contract provided such meetings could have an impact on the contractual relations between the Principal and the Contractor. The parties offer to the Monitor the option to participate in such meetings.

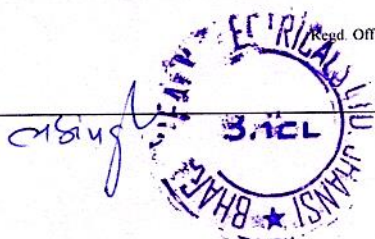



Ref: E4229001

BHARAT HEAVY ELECTRICALS LIMITED

(A Govt. of India Undertaking)

MM (PURCHASE), JHANSI – 284120

Phone : 0510-2412716

Email: mulayam@bhel.in

Schedule - VI

- 8.5 As soon as the Monitor notices, or believes to notice, a violation of this agreement, he will so inform the Management of the Principal and request the Management to discontinue or take corrective action, or heal the situation, or to take other relevant action. The Monitor can in this regard submit non-binding recommendations. Beyond this, the Monitor has no right to demand from the parties that they act in a specific manner, refrain from action or tolerate action.
- 8.6 The Monitor will submit a written report to the CMD, BHEL within 8 to 10 weeks from the date of reference or intimation to him by the Principal and, should the occasion arise, submit proposals for correcting problematic situations.
- 8.7 The CMD, BHEL shall decide the compensation to be paid to the Monitor and its terms and conditions.
- 8.8 If the Monitor has reported to the CMD, BHEL, a substantiated suspicion of an offence under relevant IPC / PC Act and the CMD, BHEL has not, within reasonable time, taken visible action to proceed against such offence or reported it to the Vigilance Office, the Monitor may also transmit this information directly to the Central Vigilance Commissioner, Government of India.
- 8.9 The number of Independent External Monitor(s) shall be decided by the CMD, BHEL.
- 8.10 The word 'Monitor' would include both singular and plural.

Section 9 - Pact Duration

- 9.1 This Pact begins and shall be binding on and from the submission of bid(s) by bidder(s). It expires for the Contractor 12 months after the last payment under the respective contract and for all other Bidders 6 months after the contract has been awarded.
- 9.2 If any claim is made / lodged during this time, the same shall be binding and continue to be valid despite the lapse of this pact as specified as above, unless it is discharged/ determined by the CMD, BHEL.

Section 10 - Other Provisions

- 10.1 This agreement is subject to Indian Laws and jurisdiction shall be registered office of the Principal, i.e. New Delhi.
- 10.2 Changes and supplements as well as termination notices need to be made in writing. Side agreements have not been made.
- 10.3 If the Contractor is a partnership or a consortium, this agreement must be signed by all partners or consortium members.
- 10.4 Should one or several provisions of this agreement turn out to be invalid, the remainder of this agreement remains valid. In this case, the parties will strive to come to an agreement to their original intentions.
- 10.5 Only those bidders / contractors who have entered into this agreement with the Principal would be competent to participate in the bidding. In other words, entering into this agreement would be a preliminary qualification.

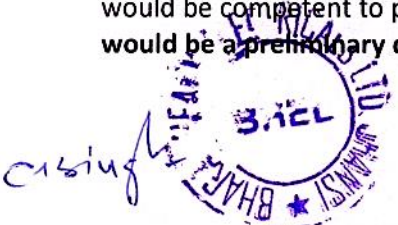



Ref: E4229001

BHARAT HEAVY ELECTRICALS LIMITED

(A Govt. of India Undertaking)

MM (PURCHASE), JHANSI – 284120

Phone : 0510-2412716

Email: mulayam@bhel.in

14

6.0 The detail of IEM for BHEL Jhansi is as under :-

	Name	Mail ID
1	Shri Arun Chandra Verma IPS (Retd.)	<u>acverma1@gmail.com</u>
2	Shri Virendra Bahadur Singh IPS (Retd.)	<u>ybsinghips@gmail.com</u>

Note: Pending nomination of new IEM for the specific tender, prospective suppliers / bidders may address their complaints / representation as envisaged in the IP to the Head (MM) of BHEL Jhansi.

(Ch Mulayam)
Manager / CMM

For and on behalf of
Bharat Heavy Electricals Ltd, Jhansi

For & On behalf of the Principal
(Signature with Office Seal)



For & On behalf of the Bidder / Contractor
(Signature with Office Seal)

Place : Jhansi

Place : _____

Date : 05/05/22

Date: _____

Witness 1: [Signature]

Witness 2: _____

(Name & Address) : SAURABH GUPTA Name & Address) _____
BHEL - Jhansi

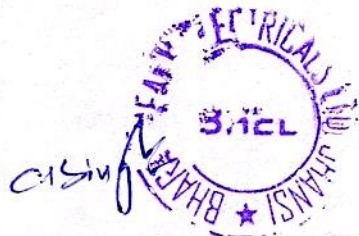

13



Ref: E4229001

BHARAT HEAVY ELECTRICALS LIMITED

(A Govt. of India Undertaking)

MM (PURCHASE), JHANSI – 284120

Phone : 0510-2412716

Email: mulayam@bhel.in

ANNEXURE-MII

**BHARAT HEAVY ELECTRICALS LIMITED, JHANSI
CENTRAL MATERIAL MANAGEMENT – TMM DIVISION**

For this Procurement, Government of India Public Procurement (Preference to Make in India), Order 2017 with its amendments and subsequent Orders issued by the respective nodal ministries shall be applicable even if issued after issue of this NIT but before finalization of contract/PO/WO against this NIT.

As per the Provisions of this order, please submit a self-certification complying with the conditions below on company letterhead duly signed by competent authority.

I, hereby declare on behalf of M/s. that we are participating in the Enquiry No. floated by BHEL, JHANSI (UP), India and shall comply with following:

1. Public Procurement (Preference to Make in India), Order 2017 with its amendments and subsequent Orders issued by the respective nodal ministries shall be applicable even if issued after issue of this NIT but before finalization of contract/PO/WO against this NIT.

2. As per the Provisions of this order, only "Class-I Local Suppliers"/ "Class-II Local Suppliers" are eligible to bid for the tender.

(a) A supplier will be treated as "Class-I Local Suppliers", if the items quoted by bidder have local content equal to or more than 50%.

(b) A supplier will be treated as "Class-II Local Suppliers", if the items quoted by bidder have local content more than 20% but less than 50%.

(c) 'Local Content' means the amount of value added in India, which shall be total value of item quoted (excluding net domestic indirect taxes) minus the value of imported content in the item (including all custom duties) as a proportion of the total value, in percent.

3. I hereby declare that our firm qualifies as "Class-I Local Suppliers" or "Class-II Local Suppliers".

a. The Local Content in the items quoted under this Enquiry is Percent

b. Details of location(s) in India where this value addition shall be done, is/are as follows:

(a)

(b)

(c)

(.....)

For M/s.

(Seal & Sign)

Note: As per GOI order No:P-45021/2/2017-PP (BE-II) dtd 04.06.20, in case of procurement is more than ₹ 10 Crores, the class-I local supplier/class-II local supplier shall be required to provide a certificate from a practicing cost accountant or practicing chartered accountant giving the percentage of local content.

Handwritten signature and circular stamp of BHEL Jhansi.



Form No. 2038

उत्पाद मानक
परिणामित्र
शाप/अभि. निर्देश

PRODUCT STANDARD
TRANSFORMER
SHOP/ENGG INSTRUCITONS

TR 10141C

3पृष्ठों में 1

PAGE 1 OF 3

TITLE: - DIMENSION AND TOLERANCES FOR CORE**General:** This specification governs the dimensions and tolerances on core assembly.**Compliance with standards:** There is no National /International standards covering the above requirements. However following dimensions and tolerances are derived to control the process of core manufacturing. In case of any deviation, it should be referred to Engineering Department for review and clearance.**1.0 CORE DIMENSIONS :-**

- 1.1 **DIAMETER :-** This is to be multiple of 2mm.
- 1.2 **LEG LENGTH :-** This is to be multiple of 2mm.
- 1.3 **LEG CENTER :-** This is to be multiple of 2mm.
- 1.4 **No. OF PACKETS :-** This is to be as given below –

CORE DIA IN mm.	MAIN LEG NO.OF PACKETS	MAIN YOKE & AUX.LEG / YOKE NO. OF PACKETS**
Up to 500	10	4
502 -760	12	4 -5
More than 760	15 Or more as specified	5

** The width and area of main and auxiliary yoke packet after merging should always be more than width and area of the packets before merging .
Refer sheet TR 10137C (pages 1 to 3 for figures.)

1.5 LAMINATION WIDTH :- This is to be multiple of 10mm, however for main yokes and outer legs of 5 limbed cores, the center packed lamination can be multiple of 5 mm.

COPYRIGHT AND CONFIDENTIAL
The Information on this document is the property of BHARAT HEAVY ELECTRICALS LIMITED. It must not be used directly or indirectly in any way detrimental to the interest of the Company.

RFF
COMP. drg

PAGE 1 OF 3

पुनः
Rev.
08
दि. Dt.
14.10.
16

IN CLAUSE 3.6, PERMISSIBLE
BURR LEVEL CHANGED TO 25
MICRON
Conia
NK *AKD*

वितरण
DISTRIBUTION.
TRE/TRM/FTM
TRX/TTG/
QC-TCB/QA-TCB/
JHANSI

सं.

स्वीकृत किया :
APPROVED : sd/- BSB, MKS

तैयार किया PREPD.
Sd/- HKM

जारी किया ISSUED
टीआरई/मानक TRE/STD.

दिनांक
DATE
17.06.91



Form No. 2038

उत्पाद मानक
परिणामित्र
शाप/अभि. निर्देश

PRODUCT STANDARD
TRANSFORMER
SHOP/ENGG INSTRUCITONS

TR 10141C

3पृष्ठो में2

PAGE 2 OF 3

2.0 TOLERANCES ON CORES :-

2.1

Core Dia in mm	ToL. On Dia in mm	ToL. On total built up thickness in mm.
Up to 400	+0	+3
	-3	-0
402 -760	+0	+4
	-4	-0
762 -1100	+0	+5
	-5	-0
Above 1100	+0	+6
	-7	-0

2.2 TOLERANCE BETWEEN CENTER LINE OF TOP & BOTTOM YOKE + 2, - 0 mm.

2.3 TOLERANCE BETWEEN CENTER LINE OF 2 CONSECUTIVE MAIN LEGS. + 1, - 0 mm.

2.4 TOLERANCES ON CORE LEANING

- 2 mm PER METER ON MAIN LEG INCLUDING YOKES.
- 3 mm PER METER ON AUX LEG INCLUDING YOKES.

ABOVE TO BE MEASURED USING PLUMB. LOCAL WAVINESS IN YOKES AT LEG LOCATION SHALL BE CHECKED AND SUITABLY ADDED/SUBTRACTED IN ABOVE VALUES DEPENDING UPON THE CORE BEHAVIOUR.

2.5 TOLERANCE ON TOP INDIVIDUAL CORE PACKET \pm 1.00 MM.

2.6 TOLERANCE ON TOP/ BOTTOM YOKE WAVINESS:

UPTO 750 Tk	: \pm 5 mm.
UPTO 1000 Tk	: \pm 10 mm.
ABOVE 1000 Tk	: \pm 15 mm,

2.7 TOLERANCE ON MAIN/ AUX LEG LAMINATION WAVINESS:

UPTO 750 Tk	: \pm 5 mm.
From 750 to 1000 Tk	: \pm 7 mm.
ABOVE 1000 Tk	: \pm 9 mm,

RFF

COMP. dfg

COPYRIGHT AND CONFIDENTIAL
The Information on this document is the property of BHARAT HEAVY ELECTRICALS LIMITED. It must not be used directly or indirectly in any way detrimental to the interest of the Company.

PAGE 2 OF 3

पुनः
Rev.
08
दि. Dt.
14.10.
16

IN CLAUSE 3.6, PERMISSIBLE
BURR LEVEL CHANGED TO 25
MICRON
Chitra
NK

AKD
AKD

वितरण
DISTRIBUTION.
TRE/TRM/FTM
TRX/TTG/
QC-TCB/QA-TCB/
JHANSI

सं.

स्वीकृत किया :
APPROVED : sd/- BSB, MKS

तैयार किया PREPD.

Sd/- HKM

जारी किया ISSUED
टीआरई/मानक TRE/STD.

दिनांक
DATE
17.06.91



TSD 6206 A

**PLANT PURCHASING SPECIFICATION
BHOPAL**

BP 10988

Rev. No. 04

PAGE 1 OF 7

SUPERSEDES
BP 10988 Rev 03**COLD ROLLED GRAIN ORIENTED SHEET STEEL
GR:27 H 103 M**
-----**1. GENERAL:**

This specification governs the quality requirements of double side insulated, cold rolled, grain oriented magnetic steel sheets of thickness 0.27mm.

2. APPLICATION:

Used in transformer cores.

3. CONDITION OF DELIVERY:

Cold rolled and annealed.

The sheet shall be supplied in side trimmed continuous coils, with insulation coating on both sides, as specified in clause 6.

4. COMPLIANCE WITH NATIONAL STANDARDS:

There is no national standard covering this type of material.

However assistance has been drawn from ASTM A 876-03 Condition F-5, Ductility Class 1.

5. DIMENSIONS AND TOLERANCES:**5.1 Sizes:**

The steel sheet shall be supplied to the dimensions specified on the order.

5.1.1 Thickness:

The thickness of the sheet shall be 0.27 mm.

5.1.2 Width:

The nominal standard width of the coil shall be 790, 840, 915 or 1000 mm.

The order shall clearly specify the width of the coil required.

Revision: Cl. 4, 6, 7, 9, 11. 2, 11.2.3,
11.3 & 13 modified
Brought upto date.

Issued by:

STANDARDS AND MATERIALS GROUP
TECHNICAL SERVICES DEPARTMENT

Rev. No.: 04

Date: 20.09.2005

Date of first issue: April 1989

COPYRIGHT AND CONFIDENTIAL

The information on this document is the property of Bharat Heavy Electricals Limited, Bhopal.
It must not be used directly or indirectly in any way detrimental to the interest of the company.

**5.1.3 Weight:**

The nominal weight of the coil shall be between 1800 and 2500 kg.

5.2 Tolerances:**5.2.1 Thickness:**

Tolerance on thickness when measured with a contact micrometer at any location, not less than 9.5 mm from an edge shall not deviate more than ± 0.025 mm from the average thickness of the test lot or coil. The outer limits of acceptable thickness shall be within the range of 0.241 to 0.305 mm.

5.2.2 Width:

The tolerance of width for side trimmed coil shall be - 0 and + 3 mm.

5.2.3 Edge Camber:

The deviation of a side edge from a straight line over 2440 mm length or fraction thereof shall not exceed 3.2 mm.

5.3 Waviness:

Sharp, short waves and buckles are extremely detrimental to the effective use of grain oriented electrical steel in flat laminations and shall be avoided in the delivered materials.

For material of width greater than 150 mm, the deviation from flatness (Wave Factor) expressed as a percentage, shall not exceed 1.5 %.

6. MANUFACTURE:

The sheet shall be of low carbon, silicon steel having silicon content around 3.15%. High permeability and low core-loss in the direction of rolling is to be achieved by appropriate metallurgical processes.

The thermally flattened material shall be coated with an inorganic surface coating type C2 and an inorganic surface coating, type C5, applied over the inherent C2 coating to provide extra surface insulation resistance on both sides as per ASTM A 876-03 condition F5.

The steel sheets shall be uniformly coated on both sides with an insulation as stated above, as part of its manufacturing process, which will withstand stress relief annealing without deterioration of its adhesion or electrical insulation value at a temperature of 790 to 840 deg.C. There shall be no change in colour of the insulation after annealing.



The insulation, coating shall be uniform throughout the length of the coil. There shall be no line marks, rough spots, shade difference, dots and patches etc.

7. **FREEDOM FROM DEFECTS:**

The material shall be clean, bright, smooth and free from dents, surface defects such as holes, scabs, pits, blisters, slivers, mill marks etc. and also free from oil, grease, dust scale and rust.

The sheet surface shall not exhibit any of these defects even after stress relief annealing at 790 deg.C to 840 deg.C.

8. **TEST SAMPLES:**

Test samples shall be selected from the consignment as follows:

8.1 **Maximum Specific Total Loss:**

One from each coil.

8.2 **Electrical & Mechanical Tests:**

One sample per consignment/lot for Mechanical Tests and Electrical Tests (Surface Insulation Resistivity and Magnetic Permeability Tests).

8.3 The test samples shall be sufficient in size to provide the necessary test pieces.

9. **TEST METHODS:**

Unless otherwise specified, the test shall be conducted in accordance with the relevant method specified in ASTM A 876-03.

10. **MECHANICAL TESTS:**

10.1 **Ductility:**

Material shall possess good shearing and punching properties and shall be sufficiently ductile to permit normal working.

The bend test shall be carried on transversely cut test specimen of 60 mm long and between 10 mm and 30 mm wide.

The test specimen shall be initially bent through 90 degrees, this bend not being counted. The specimen shall then be bent backward and forward through 160 degrees. The specimen shall complete one bend without fracture.

10.2 **Stacking Factor:**

The surface quality of the material when measured in terms of stacking factor (viz. a minimum of 16 samples under a pressure of 0.35 MPa) shall be 94.5% minimum.



11. ELECTRICAL TESTS:

11.1 Surface Insulation Resistivity:

When tested as per ASTM A 717 - Franklin's method, the surface insulation resistivity per lamination (two surfaces) of single strip specimens (5 on each side), shall show the following readings.

Average Value - 10 ohms cm², Minimum.
Individual Value - 5 ohms cm², Minimum.

11.2 Maximum Specific Total Loss:11.2.1 Cutting of Test Specimen:

Epstein test specimens measuring 30 mm wide and not less than 300 mm long, shall be cut from the sample with sharp shears. All the strips shall be cut parallel to the direction of rolling.

11.2.2 Stress - Relief Annealing:

The Epstein test specimens cut as described above, shall be annealed at a temperature of 790 deg.C to 840 deg.C for approximately 1 hour in an atmosphere comprised of a combination of pure Nitrogen and pure Hydrogen (2 to 15%). Provision shall be made for obtaining essentially perfect flatness in the magnetic test specimen in the stress relief anneal.

11.2.3 Testing:

When tested in accordance with ASTM A 343M, the specimens prepared as described in clause 11.2.1 and 11.2.2 shall be tested at a peak magnetic flux density of 1.7 T and a frequency of 50 Hz. The specific total loss shall not be greater than 1.03 watt/kg.

11.3 Magnetic Permeability Test

When tested in accordance with ASTM A 343M, the Magnetic permeability at AC Magnetizing Force of 800 A/m shall not be less than 1880 using 25 cm Epstein Test frame on 50 Hz.

Alternately the induction value at 800 A/m magnetising force shall not be less than 1.88 Tesla.

12. TYPE TEST: - Ageing*

When tested at a peak Magnetic Flux Density of 1.7T and at a frequency of 50 Hz, the specific total loss of the specimen which has been heated at a temperature of 225 deg.C for 24 hours shall not deteriorate by more than 4% of the measured specific total loss (clause 11.2) of the coil concerned.

*Note: Type tests shall be carried out when "Type Approval" to a supplier is given and repeated once in two years for the approved sources.



TSD 6207 A

**PLANT PURCHASING SPECIFICATION
BHOPAL**

BP 10988

Rev. No. 04

PAGE 5 OF 7

13. TEST CERTIFICATES:

Unless otherwise stated, three copies of certificates shall be supplied alongwith each consignment.

In addition, the supplier shall ensure to enclose one copy of the test certificate alongwith their despatch documents to facilitate quick clearance of the material.

The test certificate shall bear the following information.

BP 10988 - Rev. 04, Order No, Supplier's Name/Grade/ Identification No, Size & Weight, Packet/Bundle No, Test Results of Dimensions & Tolerances, Freedom from Defects, Details of Insulation Coating, Type Test, Properties of (a) Specific Total Loss of each coil (b) Mechanical & Electrical properties for one random coil of each lot/consignment, (c) Results of chemical composition for information only.

14. PACKING AND MARKING:

The material shall be supplied preferably in coils of continuous length. However, if it becomes unavoidable, 5% of the coils of the order can be supplied with maximum of two butt weld joints, and 95% of the coils shall be in one continuous length. The supplier shall ensure than the welds are made in such a manner without causing damage to the areas of coil adjacent to the weld. The welds shall be clearly marked by suitable tags projecting outside the coil.

The nominal diameter of the coil shall be 508 mm. Packing shall be sea worthy and shall be protected to prevent damage and rusting during transit.

Sheets shall be packed vertically according to the instructions and drawings given in the Annexure.

A metal label/tag shall be securely attached with each coil or drum or bundle outside its wrapping and shall be legibly marked with the following information.

BP 10988 : Cold Rolled Grain Oriented Sheet Steel
Gr: 27 H 103 M.

BHEL Order No.
Manufacturer's/Supplier's name.
Identification/Coil No.
Size and Quantity supplied.

GENERAL INFORMATION FOR CALCULATION

Density - 7.65 Kg/dm³.



TSD 6207 A

**PLANT PURCHASING SPECIFICATION
BHOPAL**

BP 10988

Rev. No. 04

PAGE 6 OF 7

ANNEXURE
-----**DETAILED INSTRUCTIONS FOR PACKING**

1. An annular protection board should be placed at either end of the coil.
2. The coil should then be wrapped with waterproof anti-rust crepe kraft paper by lapping axially all around the circumference.
3. The coil shall then be covered by polyethelene sheet or waterproof kraft paper and the ends sealed properly.
4. A galvanised sheet should be wrapped on the outside of the coil and the two ends. Care should be taken to ensure that the ends extend sufficiently over the inside diameter of the coil.
5. A galvanised sheet should be wrapped on the inside of the coil care should be taken that it overlaps sufficiently over the ends of the sheet mentioned in (4) above.
6. Steel rings made from thick angle sheets should be placed on the rims of the inner and outer diameters at both ends of the coil. The rings should be held at either ends at four points by steel bands.
7. The coil should then be mounted on woodenskids held together by steel bands.
8. The packing should ensure that there is no seepage of moisture and the sheets reach BHEL in completely rust free condition. It should be strong enough to withstand handling at the docks, at sea and on the road.
9. Coils should be sufficiently tight wound to prevent collapse to an extent that would preclude their being mounted on a mandrel appropriate to the ordered internal diameter.



TSD 6207 A

PLANT PURCHASING SPECIFICATION BHOPAL

BP 10988

Rev. No. 04

PAGE 7 OF 7

Press Board Protector

Galvanized Sheet

Rust-Proof Paper

Steel Band

Polyethylene Film

Shipping Mark

Wooden Platform

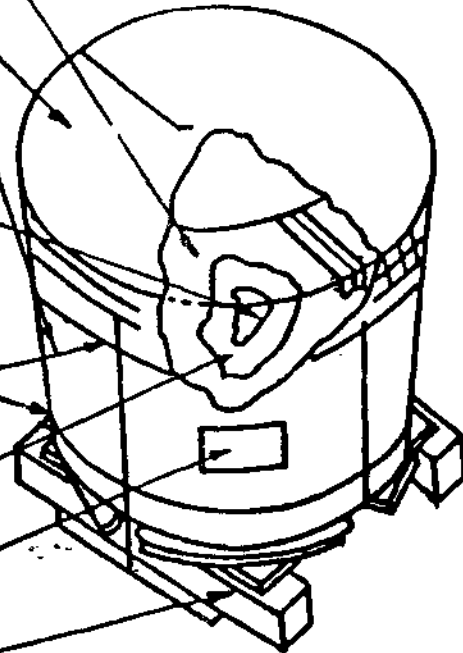

Steel Ring

508 mm

Galvanized Sheet

Press Board Protector

Polyethylene Film

Rust-Proof Paper

Coil

Hard Board

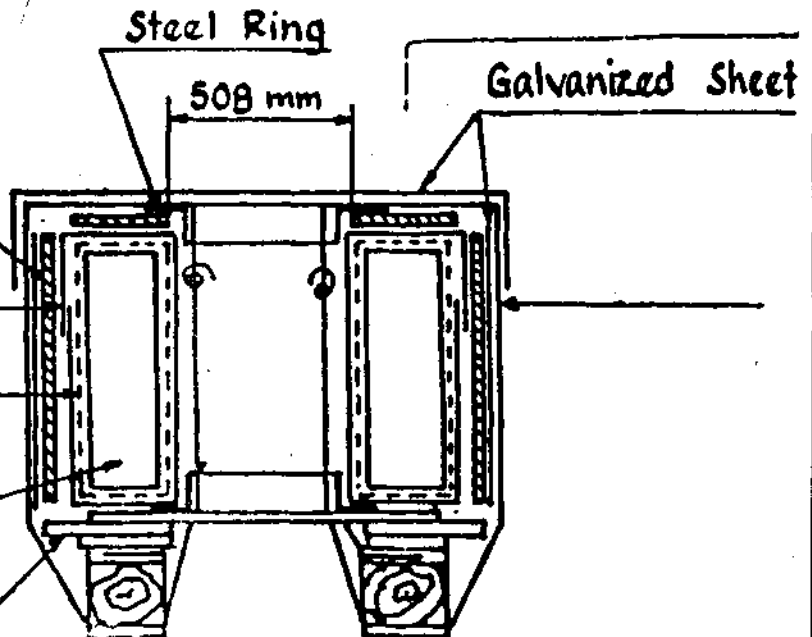

SN	Description
1	General:
A	These general terms & conditions shall apply to all enquiries, notice inviting tenders, request for quotations concerning the supply of goods and / or rendering of services to Bharat Heavy Electricals Ltd., Jhansi (hereinafter referred to as BHEL or the Purchaser) or its Projects / Customers.
B	Special / supplementary enquiry conditions& Mandatory Sheet requirements, if any, covered in the respective enquiry, will override the relevant conditions mentioned in this document.
C	Commercial Conditions quoted by the vendor in any place including as stated in bidder's 'General Terms and Conditions' if any, shall not be binding on the Purchaser. Only the conditions contained in this document, including special conditions, if any, for this enquiry shall prevail.
2	General Instructions - Common for Indigenous & Foreign enquiries
A	Sealed bids are invited for scope of Supply / Services as detailed in the enquiry. The quotation should be neatly typed and free from over writing/ erasures. Any correction or addition must be authenticated.. Relevant enclosures, supporting documents, catalogue, samples, if any, as required as per Notice Inviting Tender (NIT) conditions shall be sent along with technical offer. Rate should be quoted in the units asked for in the enquiry. The rates should be quoted both in figures and words. In case of discrepancy in figures and words, the rates quoted in words shall be considered.
B	<p>Bids shall be submitted in a Sealed cover with Enquiry No., Due date and Bidder's name indicated on the Cover. The Cover should contain both Part-I and Part –II bids, as the case may be.</p> <p><u>Part – I bid</u></p> <p>In case of Two part Bid, Part – I bid i.e. Technical bid containing (i) technical offer, (ii) Mandatory Sheet, (iii) un-priced copy of the Price Bid, (iv) EMD (if called in NIT),and (v) Relevant documents of PQR (if called in NIT), all duly filled-in & signed; should be kept in one envelope. The Part – I bid Cover items should have Enquiry No., Part I Bid, Due date, and Bidder's name indicated on the Cover</p> <p><u>Part –II Bid wherever Reverse Auction is not called for</u></p> <p>Part – II bid i.e. Price Bid containing only the price (as called for in the price format where required), duly filled-in & signed; should be kept in a separate envelope. The Price bid Cover items should have Enquiry No., Part II Bid, and Bidder's name indicated on the Cover</p> <p><u>Part –II Bid wherever Reverse Auction is called for</u></p> <p>Part – II bid i.e. Price Bid containing only the price (as called for in the price format where required), duly filled-in & signed; should be kept in a separate envelope. Wherever, BHEL informs that it proposes to conduct Reverse Auction for many items in the tender and where evaluation of the tender is on individual item basis, separate Part – II bids are to be submitted for each of the item. The Price bid Cover for each of the items should have Enquiry No., Part II Bid, Item no of Enquiry, and Bidder's name indicated on the Cover</p> <p>The envelopes indicating Part –I or Part-II, as the case may be, to be put in a bigger envelope, which should be addressed to In-charge, Tender Room, Bharat Heavy Electricals Ltd., Administration Building, Jhansi 284120. Enquiry No., due date and bidder's name must be mentioned on the bigger envelope. Offer must reach tender room of BHEL Jhansi latest by 13.15 hrs of the enquiry due date.</p> <p>In case, the bids are not submitted in the manner stated above, the offer of the bidder(s) are liable to be rejected.</p> <p>It is preferred that offers are sent in sealed envelope. However, if the bidder choses to send the offer through E-mail, offers received through E-mail shall be considered only when such offers are complete in all respects.. In cases of offers through E-mail, the offers shall be sent to tenderbox.jhs@bhel.in, wherein the Subject of the Email should mention the Enquiry Number. E mail offers sent to any other E mail ID shall not be entertained. BHEL shall not take any responsibility if the offers are incomplete or if the Enquiry number is not mentioned in the subject of the E-mail.</p>
C	Wherever BHEL proposes to issue tender through e –procurement, the same philosophy as mentioned in 2B above is ensured through suitable system locks.
D	Offer received after 13.15 hrs of the due date will be termed as "Late" and shall not be considered

GENERAL TERMS AND CONDITIONS OF ENQUIRY

E	<p>BHEL reserves the right to go for Reverse Auction (RA) (as per Guidelines available on www.bhel.com) instead of opening the sealed envelope price bid, submitted by the bidder. This will be decided after techno-commercial evaluation. Bidders to give their acceptance with the offer for participation in RA. Non-acceptance to participate in RA may result in non consideration of their bids, in case BHEL decides to go for RA. Those bidders who have given their acceptance to participate in Reverse Auction will have to necessarily submit 'Process compliance form' (to the designated service provider) as well as 'Online sealed bid' in the Reverse Auction. Non-submission of 'Process compliance form' or 'Online sealed bid' by the agreed bidder(s) will be considered as tampering of the tender process and will invite action by BHEL as per extant guidelines for suspension of business dealings with suppliers/ contractors (as available on www.bhel.com).</p> <p>The bidders have to necessarily submit online sealed bid less than or equal to their envelope sealed price bid already submitted to BHEL along with the offer. The envelope sealed price bid of successful L1 bidder in RA, if conducted, shall also be opened after RA and the order will be processed on lower of the two bids (RA closing price & envelope sealed price) thus obtained. The bidder having submitted this offer specifically agrees to this condition and undertakes to execute the contract on thus awarded rates.</p> <p>If it is found that L1 bidder has quoted higher in online sealed bid in comparison to envelope sealed bid for any item(s), the bidder will be issued a warning letter to this effect. However, if the same bidder again defaults on this count in any subsequent tender in the unit, it will be considered as fraud and will invite action by BHEL as per extant guidelines for suspension of business dealings with suppliers/ contractors (as available on www.bhel.com)</p>
F	<p>The goods offered shall conform to BHEL specifications / drawings and / or Indian / International standards as mentioned in the Enquiry and the bidder is required to confirm his unconditional acceptance to the same. Vendors, seeking deviations from the specifications and any other conditions, may indicate the same clearly on a separate sheet, with reasons for such deviations. BHEL reserves the right to reject the offer with deviations or load the deviations suitably for evaluation.</p>
G	<p>Offers shall be submitted directly by vendor or his authorized agent/representative only. Offers from any other sources shall be considered as unsolicited and shall be summarily rejected.</p>
H	<p>Bid in single part or techno-commercial bid in two part system (as the case may be) will be opened on the due date. In case of two part bid, price bids of techno-commercially acceptable bidder(s) only shall be opened on the assigned date, for which separate intimation will be sent to the acceptable bidders.</p>
I	<p>The bidder whose bid is technically not accepted will be informed & EMD wherever submitted shall be returned along with his price bid within <u>30 days</u> of contract finalization date. No interest will be payable on EMD amount. EMD shall however be forfeited in the event of bidder backing out after submission of the bid.</p>
J	<ol style="list-style-type: none"> 1. Any discount / revised offer submitted by a bidder on its own shall be considered, provided it is received on or before the due date and time of offer submission (Part-I). Conditional discounts shall not be considered for evaluation of tenders. 2. Unsolicited discounts / revised offers given after Part-I bid opening shall not be accepted. No change in price will be permitted within the validity period asked for in the enquiry. 3. In case of changes in scope and / or technical specification and / or commercial terms & conditions, having price implication, techno-commercially acceptable bidders shall be asked by BHEL to submit the impact of such changes on their price bids. A suitable cut-off date and time shall be given to all the techno-commercially acceptable bidders to submit the impact on their price bids. In case a bidder opts to submit revised price bid instead of impact called for, then their original price (i.e. previous bid) shall be necessarily opened to know the price impact. .
K	<p>The bidders will submit Integrity Pact, duly signed by its authorized signatory, if called for in the enquiry.</p>
L	<p>Wherever the enquiry is issued to unregistered vendor referred by BHEL Customer, the bidder shall submit the Supplier Registration Form (SRF) online at www.bhel.com and submit the signed copy of the duly filled-in SRF along with the bid. Price bids of such vendors, will be opened only on techno-commercial acceptance of bid and if allotted permanent code before the date of price bid opening.</p>
M	<p>BHEL expects that the bidder must respond to the enquiry. Regret letter, with valid reasons for not participating in the tender will be submitted where the bidder is unable to submit offer. Repeated lack of response on the part of vendor may lead to his deletion from BHEL's approved vendor list.</p>
N	<p>Goods shall be properly packed to avoid transit damage. Suitable markings shall be provided to identify the goods with that of the PO No, Item no. and the consignee details.</p>
O	<p>Goods shall be consigned to Manager , Stores (CRX), BHEL, Jhansi - 284120, India, unless otherwise specified in the PO.</p>
P	<p>Offers of the Bidders who are under HOLD or are under Interim Suspension or are on the banned list (as on date of Price bid opening) and / or those bidders who engage services of such suspended / banned firms, shall be rejected. The list of firms banned by BHEL is available on BHEL web site www.bhel.com. The list of firms suspended by BHEL, Jhansi is available on www.bheljhs.co.in. The " Guidelines for suspension of business dealings with Suppliers / Contractors" is uploaded on BHEL website http://www.bhel.com/vendor_registration/vendor.php</p>

Q	In case of press tenders (i.e. those published in newspapers) all corrigenda, addenda, amendments, time extensions, clarifications etc. to the tender will be hosted on BHEL website. (www.bhel.com & www.bheljhs.co.in) only. Bidders responding to press tender should regularly visit website(s) to keep themselves updated.
R	In case the bidder decides to sub-contract part of his activity / work to some of his vendors, details of such intended subcontracting shall be mentioned in the bid. This will however not absolve the bidder from his contractual obligations and responsibilities.
S	In the course of evaluation, if more than one bidder happen to occupy L-1 status and the order is to be placed on a single vendor, effective L-1 will be decided by soliciting discounts from the respective L1 bidders.. In case more than one bidder happen to occupy the L1 status even after soliciting discounts, the L1 bidder shall be decided by, a toss / draw of lots, in the presence of the respective L1 bidder(s). BHEL's decision in such situations shall be final and binding.
T	Wherever the minimum reserved capacity is called for in the tender, the offers of such bidders, who do not quote for the minimum reserved capacity, are liable to be rejected.
U	<p>Due to large qty. requirement, we may finalize the tendered quantities among more than one bidder (after acceptance of L1 price by the other bidders), but limited to the capacity quoted by the bidder. Indicate your committed capacity for the item(s) tendered and confirm that capacity offered by you against our tender shall be available for us during the entire period of the Purchase Order / Contract.</p> <p>Where the number of qualified responses (N) are three or more, the distribution shall be limited to (N-1) responses. The manner and proportion of distribution shall be mentioned in the specific enquiry. Normally, the quantity distribution shall be generally as per quantities allocated to the bidder, but limited to the capacity quoted by the bidder.</p> <p>While the manner of distribution is mentioned in the enquiry, the absolute values of the unit of measurement shall be rounded off. For eg : If an allocation of 40% quantity results in 23.5 units, the quantity allocated shall be 24 units. If an allocation of 40% quantity results in 23.3 units, the quantity allocated shall be 23 units</p> <p>The distribution shall be based on the acceptance given by bidders to the L1 price counter offered to them. In case any or all of the bidders do not accept the counter offer, and a situation arises wherein bidder(s) who have agreed to the counter offer may have to be allotted more quantity than what has been proposed earlier, then the same shall be done, but limited to the capacity quoted by the bidder (s).</p> <p>Wherever, the number of techno commercially qualified responses (N) is two, BHEL reserves the right on whether or not to distribute the quantity on more than one bidder</p> <p>While the above pattern shall also be followed in long term framework agreements (FA), performance of the suppliers shall be monitored periodically, and the loading in FA will also be subject to factors like (a) Customer approval of suppliers in specific projects, (b) quality surveillance at Supplier works, (c) Suppliers delivery and quality performance during execution of FA, (c) Pendency of orders on the supplier and (d) responsiveness in addressing post order completion issues at BHEL. In view of these factors, the loading during execution of FA may vary with respect to allocated quantity. During execution of FA, if the performance of supplier is not upto the mark in respect of delivery / quality performance / quoted capacity of the bidder, BHEL reserves the right to either reduce further loading or stop loading till the execution of overdue orders. In such cases, action shall be taken against the defaulting supplier(s) as per guidelines of the Company, and the balance allocated full or part quantity of the defaulting supplier(s) may be re-distributed amongst other performing and willing vendors of the FA..</p>
V	The bidder shall submit price bid strictly in the price format, wherever provided for, in the enquiry. Any attempt on the part of the bidder to alter the contents of the price bid format in any manner, which in the opinion of BHEL can vitiate the tendering process, will lead to rejection of the bid, <i>besides BHEL taking appropriate punitive action as deemed fit.</i>
3	Vendor's particulars & logistics information
	Bidder to provide contact details and all logistical information as called for in the Mandatory Sheet enclosed to this enquiry
4	Delivery Schedule & Completion date
A	<ul style="list-style-type: none"> • Instead of writing specific date against delivery offered, Bidder shall commit delivery period in number of days / weeks/ months to suit the delivery period indicated in the enquiry. • Commencement of delivery period shall be reckoned from the date of PO / LOI or any other agreed milestone. • Seller shall deliver the goods in the manner and schedule agreed under the Purchase order. • Goods shall be delivered within contractual period or any extension thereof, if any, granted by the Purchaser.

GENERAL TERMS AND CONDITIONS OF ENQUIRY

B.	In case of foreign supplies, bidders are to quote for CIF/CFR delivery terms .For CIF / CFR delivery terms, the date of bill of lading (BL) shall be taken as actual date of delivery.
C.	In case of Indigenous bidders, the date of delivery at named destination in India shall be taken as contractual delivery completion date where delivery terms are FOR destination. In case of 'Ex-works' delivery terms, the date of LR / RR shall be the contractual delivery completion date.
D	In case of unreasonable delivery quoted by the bidders, BHEL reserves the right to reject such offers.
5	Transit Insurance
	Except where delivery terms are agreed on CIF basis for Imports & FOR destination basis for indigenous purchases, transit insurance will be covered by BHEL under its open Marine Insurance Policy. Seller shall inform dispatch particulars with value of consignment to the Purchaser within 07 days of dispatch for BHEL to arrange insurance coverage in its policy. Failure on the part of seller to inform dispatch particulars will make him liable to pay for any transit damages / losses suffered by the Purchaser.
6	Delivery Terms
A	Indigenous Purchase
	Goods shall be delivered on 'FOR Destination' basis (with freight and insurance in bidder scope) to the named destination unless otherwise called for in the enquiry. In case the bidder quotes on Ex-Works, the offer of such bidder(s) is/are liable to be rejected. Wherever the PO terms mentions delivery terms as FOR Destination basis, and In the event of supplier having supplied the material by BHEL Truck / Vehicles as per BHEL transportation rate contract, thus causing BHEL to bear the freight charges, the corresponding amount ,incurred / estimated, shall be deducted from the bills of the Supplier.
B	Foreign Purchase – Imports
	<ol style="list-style-type: none"> 1. Goods shall be dispatched by sea on CIF/CFR basis, unless stated otherwise in the enquiry or purchase order. The destination shall at Navsheva, Mumbai for LCL/Breakbulk Cargo and ICD, Mandideep, Madhya Pradesh for FCL Cargo 2. If air freight is called for in the enquiry, the goods shall be delivered on FCA basis to the named Airport 3. Please visit BHEL Jhansi web site www.bheljhs.co.infor details of named Airports. . Name of the airport so chosen by the Seller shall be indicated by the Bidder in his offer. 4. Goods shall be handled for air freight by BHEL's freight forwarder only, under FCA contracts and HAWB issued by BHEL appointed forwarder or his authorized agent(s) shall only be accepted for negotiation.
C	<ul style="list-style-type: none"> • In the event of bidder offering CFR or CIF delivery terms for delivery in FCL(Full Container Load), the Bidder shall provide 14 days' time free of detention from the date of delivery at delivery port. Wherever the detention free period offered is less than 14 days, the bids shall be loaded for the period short of 14 days period. • <u>Port congestion charges or any additional charges claimed by shipping line till delivery at destination port shall be to the Seller's account.</u> •
7	Force Majeure
	<p>Notwithstanding anything contained in the contract, neither the Seller nor the Purchaser shall be held responsible for total or partial non-execution of any of the contractual obligations, should the obligation become unreasonably onerous or impossible due to occurrence of a 'Force Majeure' which directly affects the obligations to be performed by the Purchaser or the Seller; Such events include war, military operations of any nature, blockages, revolutions, insurrections, riots, civil commotions, insurgency, sabotage, acts of public enemy, fires, explosion, epidemics, quarantine restrictions, floods, earthquake, or acts of God, restrictions by Govt. authorities; over which the Seller or the Purchaser has no control.</p> <p>The party claiming to be affected by force majeure shall notify the other party in writing without delay, within two weeks on the intervention and on the cessation of such circumstance. Extension of time sought by the Seller along with supporting evidence and so granted by the Purchaser for the supply/ work affected, if any, shall not be construed as waiver in respect of remaining deliveries. Rescheduling of deliveries on account of force majeure conditions, if so agreed by the Purchaser, will not entail the Seller to claim any increase in the price on whatsoever account.</p>

	Notwithstanding above provisions, Purchaser shall reserve the right to cancel the order/ Contract, wholly or partly, in order to meet the overall project schedule and make alternative arrangements. If deemed necessary, Purchaser may takeover partly processed material at a mutually agreed price.
8	LD / Penalty for delayed performance.
A	<p>I. Subject to force majeure conditions, LD shall be 0.5% of the total order value per week of delay or part thereof, subject a maximum of 10% of the total order value.</p> <p>II. In case of staggered delivery schedule, LD shall be 0.5% of the undelivered portion per week or part thereof subject to a maximum of 10% of the undelivered portion .</p> <p>III. However in case of Capital Machine / BOP where staggered deliveries may be applicable, the LD cap will be levied on total order value inclusive of E&C charges. (15%)</p> <p>IV. Wherever Erection & Commissioning (E& C) is called for, the vendor is provided a stipulated period from date of site readiness. LD shall be applicable for any delay beyond the stipulated period mentioned in the PO.</p> <p>V. In case of any amendment / revision, the LD shall be linked to the amended / revised PO value.</p> <p>VI. Any loading on LD clause shall be to the extent to which it is not agreed to by the bidder (at offered value)</p> <p>For the sake of clarity – Total order value means purchase order value (exclusive of taxes), Undelivered portion means , the delayed portion for the given lot.</p> <p>In case a supply is rejected and the same is replaced at a later date, the date of replacement of accepted supply shall be reckoned for calculation of LD</p>
B	In case the contractually agreed delivery date falls on a holiday in BHEL Jhansi, the next working day shall be taken as contractual delivery date for compliance and applicability of LD / penalty.
C	<p>In case of Ex works Delivery terms for Indigenous supplies, the date LR shall be reckoned for LD deduction.</p> <p>In case of FOR Delivery terms, the date of entry in BHEL Jhansi (CISF date) shall be reckoned for LD deduction.</p> <p>In case of FCA Delivery terms / Ex Works Delivery terms of Foreign supplies , the date Invoice / Packing List / Test Certificate, whichever date is later, shall be reckoned for LD deduction.</p> <p>In case of FOB / CIF / CFR / CIP Delivery terms, the date of Bill of Lading , shall be reckoned for LD deduction.</p>
	Risk Purchase.
C	If the material is not supplied within the agreed delivery period, BHEL reserves the right to cancel the order and purchase the material(of the undelivered portion) from alternate source(s) at the Risk and Cost of the Seller. In such an event, it shall be obligatory on the part of seller to make good any loss suffered by the purchaser. In such cases, BHEL shall withhold bills, bank guarantees, etc of the Supplier, which are pending either at BHEL, Jhansi or any other Unit of BHEL . Wherever Risk purchase is invoked attracting action as per guidelines of the Company, action shall be initiated to suspend business dealings with the Supplier. To know the implications of suspension, the bidder may see the “ Guidelines for suspension of business dealings with Suppliers / Contractors” which is uploaded on BHEL website http://www.bhel.com/vender registration/vender.php
9	Indian Agents and Agency commission
A	BHEL prefers to deal directly with Foreign vendor, wherever required, for procurement of Goods. However if the Foreign Principal desires to avail services of an Indian Agent, then the Principal should ensure compliance to “regulatory guidelines” which will require submission of an agency agreement. The agency agreement should specify the precise relationship between the foreign OEM / foreign Principal and their Indian Agent. Any payment which the Indian agent receives in India or abroad from the OEM, whether as commission or as a general retainer fee, should be brought on record in the agency agreement.
B	The CIF price quoted will be deemed to be inclusive of Indian Agency commission. Agency commission as disclosed by the bidder in his quoted CIF price will be paid in Indian Rupees on receipt & acceptance of Materials or it's installation at destination, as the case may be. The lower of the TT selling rate prevailing on the date of (a_ technical bid opening, or (b) price bid opening, or (c) date of invoice, shall be considered for computation of Agency commission.
C	Be it a case of a Foreign / Indigenous Principal or OEM, in a tender either the Indian Agent on behalf of Principal / OEM or the Principal / OEM itself can bid, but both cannot bid simultaneously for same item / product in the same Tender. In case both submit a bid in the tender, then the bid of OEM only shall be opened



JHS 2055A R03

GENERAL TERMS AND CONDITIONS OF ENQUIRY

Page 6 of 12

D	Be it a case of a Foreign / Indigenous Principal or OEM, If an agent submits Bid on behalf of the Principal / OEM, the same agent shall not submit bid on behalf of another Principal / OEM in the Tender, for the same Item / Product.									
10	Documentation:									
A	Indigenous Purchase									
	<p>Immediately on despatch of Goods, the following documents shall be necessarily sent by the Seller to the respective address(es) mentioned below</p> <table border="1" data-bbox="245 479 1527 1032"> <tr> <td data-bbox="245 479 309 674">(a).</td> <td data-bbox="309 479 719 674">Addressed to: Addl General Manager (Stores) Main Store Building BHEL Jhansi PIN-284120 Telephone . 0510-2412230</td> <td data-bbox="719 479 1527 674">Documents to be sent: (i) GST compliance Invoice – Duplicate for Transporter (ii) Challan/Despatch Advice note / Packing List etc. + 1 Photo copy (iii) Test Certificate, Guarantee / Warrantee Certificate (iv) LR/RR Duplicate for Transporter copy (v) O&M Manuals, wherever applicable</td> </tr> <tr> <td data-bbox="245 674 309 898">(b)</td> <td data-bbox="309 674 719 898">Addressed to: Dy. General Manager (Finance) Administrative Building BHEL Jhansi PIN-284120</td> <td data-bbox="719 674 1527 898">Documents to be sent: (i) GST compliance Invoice – Original for Buyer (ii) Copy of LR/RR (iii) Copy of Test Certificate (iv) PVC Calculation sheet, if any, with supporting documents. (v) MOM with BHEL Customer (if called for in the PO) in case of installation & commissioning at Customer Site (vi) Capitalization Certificate, if called for in the PO</td> </tr> <tr> <td data-bbox="245 898 309 1032">(c)</td> <td data-bbox="309 898 719 1032">Addressed to: Dy. General Manager (MM) Administrative Building BHEL Jhansi PIN-284120</td> <td data-bbox="719 898 1527 1032">Documents to be sent: (i) GST compliance Invoice – Extra copy / Photo copy (ii) Challan/Despatch Advice note (iii) Test Certificate, Guarantee / Warrantee Certificate (iv) Copy of LR/RR</td> </tr> </table> <p>In case any other documents are required, the distribution of such documents will be specified in the Purchase order.</p> <p>Further, if specified in the Purchase order, all the details and copies of documents have to be uploaded by Supplier on BHEL portal before despatch of Goods</p>	(a).	Addressed to: Addl General Manager (Stores) Main Store Building BHEL Jhansi PIN-284120 Telephone . 0510-2412230	Documents to be sent: (i) GST compliance Invoice – Duplicate for Transporter (ii) Challan/Despatch Advice note / Packing List etc. + 1 Photo copy (iii) Test Certificate, Guarantee / Warrantee Certificate (iv) LR/RR Duplicate for Transporter copy (v) O&M Manuals, wherever applicable	(b)	Addressed to: Dy. General Manager (Finance) Administrative Building BHEL Jhansi PIN-284120	Documents to be sent: (i) GST compliance Invoice – Original for Buyer (ii) Copy of LR/RR (iii) Copy of Test Certificate (iv) PVC Calculation sheet, if any, with supporting documents. (v) MOM with BHEL Customer (if called for in the PO) in case of installation & commissioning at Customer Site (vi) Capitalization Certificate, if called for in the PO	(c)	Addressed to: Dy. General Manager (MM) Administrative Building BHEL Jhansi PIN-284120	Documents to be sent: (i) GST compliance Invoice – Extra copy / Photo copy (ii) Challan/Despatch Advice note (iii) Test Certificate, Guarantee / Warrantee Certificate (iv) Copy of LR/RR
(a).	Addressed to: Addl General Manager (Stores) Main Store Building BHEL Jhansi PIN-284120 Telephone . 0510-2412230	Documents to be sent: (i) GST compliance Invoice – Duplicate for Transporter (ii) Challan/Despatch Advice note / Packing List etc. + 1 Photo copy (iii) Test Certificate, Guarantee / Warrantee Certificate (iv) LR/RR Duplicate for Transporter copy (v) O&M Manuals, wherever applicable								
(b)	Addressed to: Dy. General Manager (Finance) Administrative Building BHEL Jhansi PIN-284120	Documents to be sent: (i) GST compliance Invoice – Original for Buyer (ii) Copy of LR/RR (iii) Copy of Test Certificate (iv) PVC Calculation sheet, if any, with supporting documents. (v) MOM with BHEL Customer (if called for in the PO) in case of installation & commissioning at Customer Site (vi) Capitalization Certificate, if called for in the PO								
(c)	Addressed to: Dy. General Manager (MM) Administrative Building BHEL Jhansi PIN-284120	Documents to be sent: (i) GST compliance Invoice – Extra copy / Photo copy (ii) Challan/Despatch Advice note (iii) Test Certificate, Guarantee / Warrantee Certificate (iv) Copy of LR/RR								
B	Foreign Purchase – Imports									
	<p>Seller shall send 1 set of following documents, in English, within 7 days of BL date by courier to the Purchaser</p> <ol style="list-style-type: none"> 1. Original Clean on board Bill of lading. 2. One set of Commercial Invoice, Packing list indicating container-wise Gross weight, net weight, CBM (cubic metre) volume, No. of packages with Dimensions of each package. 3. Original certificate of Country of Origin issued by Chamber of Commerce 4. One set of Original test certificates and O&M manual where called for. 5. Fumigation certificate wherever cargo is packed in wooden packing or packing of Plant origin material is used. <p>In case the Seller decides to negotiate all 3 originals of BL through negotiating Bank, non-negotiable documents (NND) consisting of copy of BL / HAWB & all originals at sl.no. 10-B2 to B5 will be couriered to Purchaser. Soft Copy of documents at sl. 10-B1 to B5 will also be sent by e-mail to the Purchaser at the e-mail address given in the PO. Other documents, as required, will be separately indicated in the Purchase Order. Additional expenditure, if any, incurred by the Purchaser by way of detention / demurrage, resulting out of delay attributable to the Seller in providing negotiable documents, will be recovered from the Seller.</p>									
C	In case of incomplete documentation, the communication shall be provided to supplier. The delays in submission of documentation by the supplier shall be reckoned while releasing payments to the Supplier									
11	Pricing Terms									
	Prices once quoted shall remain firm within the validity or any extension thereof for placement of order, till complete execution of the order, without any escalation/increase for any reason, whatsoever, unless specifically provided for in the Enquiry & PO. In case of foreign vendors, the quoted price shall be taken as inclusive of Third Party Inspection and testing charges as called for in the NIT.									

12	Price Validity :
	<p>Unless stated otherwise in the enquiry, offer shall be valid for a period of 120 days from the date of Techno- commercial (Part-I) bid opening date.</p> <p>The prices quoted for spare parts of the main equipment shall be kept valid for a period of 180 days from the date of placement of PO for the main equipment.</p>
13	Taxes & Duties - Indigenous Purchase
A	<p>The Taxes and duties as applicable shall be payable extra which may include GST against Gate pass- The Seller shall clearly indicate extent of taxes as applicable in his techno commercial bid. In the event of vendor failing to furnish valid GST invoices with appropriate HSN Code , amount corresponding to GST will be disallowed by BHEL while making payments.</p> <p>Bidders to ensure applicability of IGST / CGST/SGST based on the Inter / Intrastate movement of goods.</p> <p>GST Registration Number (GSTIN) should be clearly mentioned on the vendor's quotation.</p> <p>Please quote our IGST registration number 09AAACB4146P2ZC in all invoices raised for supply of goods and services under GST regime and also ensure filing of timely return and payment of tax and compliance of other applicable provisions on supplier under GST regime.</p> <p>In the event of any disallowance of input credit or applicability of interest or any other financial liability arises on BHEL- Jhansi due to any default of supplier under GST such implication shall be to supplier's account.</p> <p>GST shall be levied on LD and the relevant tax invoice shall be provided to vendors for availing credit.</p> <p>In case of directly despatchable items to Customer's Site, Supplier to bill to BHEL Jhansi at its GST Account number 09AAACB4146P2ZC and ship to the respective Customer</p> <p>Since, input credit of GST will be available to BHEL-Jhansi only after correct filing of return and payment of applicable GST by supplier, reimbursement of GST shall be made by BHEL-Jhansi on matching of vendor inputs at GST portal and after ensuring availability of input credit to BHEL-Jhansi. Payment of tax shall be done only after availing matching ITC, in all cases where bills are submitted directly to BHEL-Jhansi or through bank or under LC or through any other mode.</p> <p>Other statutory declaration forms are also to be submitted in time, as mentioned in the relevant Laws. BHEL reserves the right to withhold the payment due to the vendor equivalent to BHEL's tax and related liability thereon.</p> <p>In case of any changes in statutory laws w.r.t. taxes and duties, the same shall be applicable at the given point of time.</p>
B	<i>Wherever GST is not applicable, the tax and duty structure , as applicable, is to be complied by the seller.</i>
14	Taxes & Duties - Foreign Purchase – Imports
A	The offered prices shall be inclusive of all the Taxes and duties as applicable in the country of bidder / country of dispatch for the quoted FCA / CFR/CIF price.
15	Payment Terms-
A	<p>Indigenous: 100 % payment within 90 days (45 days for MSE / NSIC registered suppliers as per relevant act in force) from the date of receipt of material and submission of clear and admissible bill, subject to acceptance of material at BHEL , on direct presentation of the documents..</p> <p>Payments to vendors who are seeking benefits under MSME act shall not be entertained if the Udyog Aadhar Memorandum (UAM) submitted by them is not valid on the date of Purchase Order and date of supply (SRV Date of BHEL) . It is hence in the interest of the vendor that they validate the status of UAM regularly with BHEL.</p> <p>In case of despatch of material to site directly, site certification for receipt of materials is required unless otherwise provided for in the PO. Any deviation from the above payment terms, if accepted (by BHEL), shall be loaded @ SBI base rate(as on date of Part I bid opening) + 6%, for the purpose of bid evaluation.</p>

GENERAL TERMS AND CONDITIONS OF ENQUIRY

	<p>All documents as called for in the PO have to be submitted by the Supplier at the time of receipt of material and this should include the Invoice of the Supplier - Original copy of the Buyer and Duplicate for Transporter. On receipt of Invoice, the same shall be acknowledged by BHEL. Any clarifications on the bill submitted by the supplier shall be sought generally within 30 days (15 days for MSE / NSIC registered suppliers as per relevant act in force) of receipt of bill at BHEL. While it would be in the interest of the Supplier to provide the reply immediately to the clarifications sought , the Supplier is to respond at least within 7 days from the date of clarifications sought by BHEL. Wherever clarifications are sought by BHEL, the date of receipt of clarifications from the supplier shall be considered as date of submission of clear and admissible bill.</p>						
B	<p>Foreign: 100% against irrevocable, unconfirmed LC, payable within 120 days of the bill of lading (BL) date. In case BHEL considers any deviation in payment terms i.e. early payment based on vendor's request, then bids shall be evaluated with loading of State bank of India Base rate (as on date of Part I bid opening) plus 6%, for the credit period short of 120 days. The LC shall be established 2 month prior to shipment date, valid for period of 120 days, unless agreed otherwise. Payment terms of CAD payable on 120th day of BL / HAWB date shall be preferred.</p>						
C	<p>While there could be exceptional situations wherein the payment may be delayed beyond the stipulated time mentioned above, it is clarified that BHEL shall not pay any interest on such delays</p>						
D	<p>In case of any disagreement between BHEL and the Supplier on any part of the bill, such part shall be severed from the rest and payment against agreed and admissible part shall be processed as per laid down procedure, while the disputed part shall be dealt as per contract provisions viz. conciliation, dispute resolution, arbitration, etc</p>						
16	<p>Inspection of Goods</p>						
A	<p>The Seller shall give adequate notice, of 1 week or as mutually agreed period, in writing to the Purchaser about the date and place at which the goods will be ready for inspection/ testing, as provided for in the contract.</p>						
B	<p>Purchaser or his authorized representative shall be entitled to carry out inspection of material and workmanship at Seller's premises or at his sub-contractor's premises at all reasonable times during execution of contract; Such inspection, examination and testing, if made, shall not absolve the Seller from his obligations under the contract.</p>						
C	<p>All costs related to inspections and re-inspections shall be borne by the Seller. In case of foreign vendors, the cost of third party inspection, where called for, shall be deemed to be included in the quoted price. Seller shall be responsible to provide assistance such as labour, materials, electricity, fuels, stores, apparatus, instruments at his cost, as may be required and as may be reasonably demanded to carry out such tests effectively.</p>						
D	<p><u>Undertaking to be provided by Suppliers before despatch</u> : The suppliers , before despatching the jobs, shall provide an undertaking on their letterhead, that the jobs have been made as per BHEL Specification / Drawings, that the test results meet the specified parameters of the drawing / specification, that the supplies have been inspected as per Quality Plan (if called for in the Purchase Order), that on receipt of supplies at BHEL, Jhansi; BHEL reserves the right to reject any supplies which are non compliant, that in case the material is accepted with deviationst wherever rectifications / rework is observed, that the Supplier shall be given seven days notice to attend to the work and if the Supplier does not attend the rectifications in the said period, BHEL shall reserve the right for suitable deductions.</p> <p>Despatch clearance shall be given when the Supplier provides the above undertaking (as per Annexure I) to BHEL</p>						
E	<p><u>Uploading despatch information on BHEL SIP</u></p> <p>The supplier has to upload despatch information details by logging in at 'Supplier Information Portal' of BHEL Jhansi website using their User name (Vendor Code) and Password. Subsequently, the supplier has to click at the link'Update Consignment details' provided therein.Submitting 'Despatch Intimation' is mandatory. All supplies arriving (reaching BHEL Jhansi) will be allowed inside CISF Material gate of BHEL Jhansi only if the supplier has submitted online Despatch Intimation .</p> <p>The following documents are necessary before entry of material at our Material Gate:</p> <table border="1" style="width: 100%; border-collapse: collapse;"> <tr> <td style="width: 5%; text-align: center;">1</td> <td>GST Invoice OR Delivery Challan (as per rule 55) OR Bill of entry for imports OR Excise Duty Invoice for Petroleum supplies</td> </tr> <tr> <td style="text-align: center;">2</td> <td>Lorry Receipt (LR) OR Railway Receipt (RR) OR Door Delivery (Courier Docket..).</td> </tr> <tr> <td style="text-align: center;">3</td> <td>'Despatch Intimation' (Printout required).</td> </tr> </table>	1	GST Invoice OR Delivery Challan (as per rule 55) OR Bill of entry for imports OR Excise Duty Invoice for Petroleum supplies	2	Lorry Receipt (LR) OR Railway Receipt (RR) OR Door Delivery (Courier Docket..).	3	'Despatch Intimation' (Printout required).
1	GST Invoice OR Delivery Challan (as per rule 55) OR Bill of entry for imports OR Excise Duty Invoice for Petroleum supplies						
2	Lorry Receipt (LR) OR Railway Receipt (RR) OR Door Delivery (Courier Docket..).						
3	'Despatch Intimation' (Printout required).						

The following documents are additionally required for **SRV clearance** if they are called for in the Purchase Order (PO):

4	Complete Test certificates/Inspection reports
5	Guarantee certificates
6	Any other document as called for

Following may be required for **SRV preparation** depending on the nature of material being supplied:

7	Packing lists, wherever applicable.
8	Weighment slip.

A cost of one percent of the transaction value (not more than Rs 5000 per transaction but not less than Rs 500 per transaction) shall be deducted from supplier bills in case supplier has failed to upload the despatch information on Supplier Information Portal

- E** Material despatched one month prior to the date of despatch shall not be permitted inside BHEL, unless there are instructions otherwise from BHEL. In all such cases, material will be allowed inside only if approved by Head MM
- Material despatched 10 weeks after date of despatch shall not be permitted inside BHEL, unless there are instructions otherwise from BHEL. In all such cases, material will be allowed inside only if approved by Head MM

17 Warranty , Corresponding Repairs / Replacement of Goods, and Deductions

Goods shall comply with the specifications for material, workmanship and performance.

The warranty shall be for a period of 24 months from the date of receipt at BHEL, Jhansi

However, **wherever erection & commissioning also is in the scope of the bidder**, the warranty shall be for a period of 24 months from the date of supply or 18 months from the date of commissioning, whichever is later.

In case any other terms are to be specified for warranty, the same shall be specified in the specific enquiry

A Normally deviation shall not be accepted for the criteria of warranty period. The offers of bidders, who offer deviation to the warranty terms mentioned in the NIT, are liable to be rejected.

If the item supplied is found non-compliant during the warranty period, leading to rejection, the Seller shall arrange free replacement / repair of goods, within one month from the date of intimation or any mutually agreed period. The rejected goods shall be taken away by the Seller at his cost and replaced on Delivered Duty Paid (DDP) (FOR - BHEL Stores/ designated destination basis) within such period. In the event of the Seller's failure to comply, Purchaser may take action as appropriate, including Repair / Replenish rejected goods & disposal of rejections, at the risk & cost of the Seller.

In case the defects attributable to Seller are detected during processing of the goods at purchaser's/ his subcontractor's works, the Seller shall be responsible for free replacement/ repair of the goods as required by the purchaser.

18 Evaluation and Loading Criteria:

Evaluation of the tender shall be on the basis of delivered cost, i.e. 'total cost to BHEL' w.r.t the finalized technical scope and commercial conditions (after considering, inter alia, Customs Duty and CENVAT/ VAT/ CST/Service Tax/Entry Tax or any other tax as applicable). Exchange rate (TT selling rate of State Bank of India) applicable on the date of Part-I bid opening shall be considered for evaluation of foreign bids. If the relevant day happens to be a bank holiday in India, then the FOREX rate as on the previous bank working day shall be taken for evaluation.

Foreign suppliers shall ensure that the benefits as applicable under Free Trade Agreement (FTA) with Government of India are disclosed in the bid & relevant documents such as Certificate of Country of Origin, issued by the appropriate authority in the country of Export, is provided by the vendor along with dispatch documents. Bids shall be evaluated with such applicable benefits. In the event of Seller failing to provide appropriate documents for Purchaser to avail disclosed

	<p>concessional duty benefits in India, the cost incurred owing to consequent delays, detention and demurrage thereof, will be to the Seller's account.</p> <p>To arrive at the Delivered Cost, the quoted price shall be suitably loaded, the details of which are mentioned in this annexure / special remarks of the enquiry. In case of any additional techno commercial deviations, for which the loading criterion is required to be framed after opening of techno commercial bid, such criteria shall be communicated to all qualified bidders before price bid opening.</p>
19	Non-Disclosure Agreement
	<p>All Drawing and technical documents relating to the product or its manufacture submitted by one party to the other, prior or subsequent to the formation of contract, shall remain property of the submitting party. Drawing, technical documents or other technical information received by one party, shall not without the consent of the other party, be used for any other purpose than that, for which they were provided. Such technical information shall not without the consent of the submitting party, otherwise be used or copied, reproduced, transmitted or communicated to a third party. Patterns supplied by BHEL will remain BHEL's property which shall be returned by the bidder on demand to BHEL. Bidder shall in no way share or use such intellectual property of BHEL to promote his own business with others. <u>BHEL reserves the right to claim damages from the bidder, or take appropriate penal action as deemed fit against the bidder, for any infringement of the provisions contained herein.</u></p>
20	RIGHT OF REJECTION /NON- PLACEMENT OF PO/ SHORTCLOSURE OF PO: BHEL reserves the right to accept the offers in part or in full, or cancel the Tender enquiry without assigning any reason whatsoever / non placement of PO or contract / short closure of PO or contract.
21	Performance Bank Guarantee (PBG)/ Security Deposit (SD):
A	Bank Guarantee wherever called for, shall be in the BHEL prescribed format. In case the order is to be placed in foreign currency, the BG must normally be in Indian Currency from the Consortium Banks of BHEL / as specified in the specific Enquiry
B	Wherever the contract is for supply of Goods processed on labour basis from BHEL supplied materials, the materials shall be issued against a suitable security, preferably Bank guarantee.
22	Benefits earmarked for Purchase from Micro & Small Enterprises (MSEs) – Indigenous Purchase
A	MSE suppliers who are registered by bodies like MSMED, NSIC & DIC specified by Ministry of Micro, Small and Medium Enterprises (MoMSME) can avail the intended benefits only if they submit along with the offer, relevant documents including valid certificate as mentioned in " Format for Supplier MSME Status' on Supplier Information Portal of BHEL, Jhansi. In case the valid MSE registration of the bidder is already updated in SDC records of BHEL, Jhansi, it may not submit the details again. It is hence in the interest of the supplier that they validate the status of UAM regularly with BHEL, if they would like to avail intended benefits under MSME Act.
B	Tenders to MSE suppliers shall be issued free of cost & no EMD wherever called for will be insisted upon. Such MSE bidders shall submit along with bid, relevant documents including valid certificate. Date to be reckoned for determining the deemed validity will be the date of bid opening (Part I in case of two part bid). Non- submission of such document will lead to consideration of their bid, at par with other bidders. No benefit shall be applicable for this enquiry if any deficiency in the above required documents are not submitted before price bid opening. If the tender is to be submitted through e-procurement portal, then the above required documents are to be uploaded on the portal. Documents should be notarized or attested by a Gazetted Officer.
C	In tender, participating MSEs quoting price within price band of L1 (on total cost to BHEL) +15% shall also be allowed to supply a portion of requirement by bringing down their price to L1 price in a situation where L1 price is from someone other than a MSE and such MSE shall be allowed to supply up to 20% of total tendered quantity. In case of more than one such MSE within price band of L1 (on total cost to BHEL) +15%, the supply shall be shared proportionately (to tendered quantity, as per their tender ranking of the bidders and also their SC/ST status). However if there are more than one MSE vendor at the same price level, then the quantity shall be distributed equally. A quantum of 4% out of 20% quantity, so earmarked, will be reserved for MSE's owned by SC / ST entrepreneurs who submit their bid with relevant documents. However, such distribution shall be subject to the tender requirement in terms of Customer approval of vendors, divisibility of quantity, etc. While all efforts shall be made to ensure compliance to the stated distribution, the decision of BHEL in distribution stated in this clause shall be binding on all bidders.

	The above distribution is not applicable (a) where L1 vendor is MSE vendor and minimum 20% share is assured to the L1 bidder in the tender, or (b) where the MSE bidders qualified for distribution as per 'manner of splitting' clause in NIT already cater to 20% share in the tendered load.
D	In case it comes to notice that the bidder is found responsible for misconducts like, having submitted fake/false/forged documents/ certificates, has misrepresented the facts, has wilfully suppressed the facts, has resorted to unethical/ illegal means, etc., action shall be initiated against such bidders as per the extant guidelines of the Company for suspension of business dealings.
23	Benefits earmarked to suppliers for Purchase under 'MAKE IN INDIA'
	As part of minimizing import content, Government of India, vide order no P-45021/2/2017-B.E.-II dated 15.06.2017, under the subject – Public Procurement (Preference to Make in India) -- has set the initiatives to encourage and promote indigenously manufactured goods within India and services provided by sources within India. . In line with this, bidders who manufacture the goods and provide services within India (otherwise referred as local suppliers) are given purchase preference and are entitled to benefits in the tender
A	Definitions
(i)	Local content means the amount of value added in India which shall, unless otherwise prescribed by the Nodal Ministry, be the total value of item procured (excluding net domestic indirect taxes) minus the value of imported content in the item (including all customs duties) as a proportion of the total value , in percent . Presently, the minimum local content required is 50%. The nodal ministry may prescribe a higher or lower percentage in respect of any particular item and may also prescribe the manner of calculation of local content.
(ii)	Local supplier means a supplier or service provider whose product or service offered for procurement meets the minimum local content as prescribed
(iii)	Margin of Purchase Preference means the maximum extent to which the price quoted by a local supplier may be above the L1 for the purpose of purchase preference. Presently the margin of Purchase preference is 20%.
B	Conditions under which preference is given
(i)	In procurement of goods in respect of which the Nodal ministry has communicated that there is sufficient local capacity and local competition, and where the estimated value of procurement is Rs 50 lakhs or less, only local suppliers shall be eligible. If the estimated value of procurement of such goods is more than Rs 50 lakhs, provisions of 23(B) (ii) and 23(B)(iii) shall apply.
(ii)	If the procurement of goods are not covered by 23(B)(i) and are divisible in nature, the following procedure shall be followed :
a	If L1 is a local supplier, the order for full quantity shall be awarded to local supplier
b	If L1 bid is not from a local supplier, 50% of the order quantity shall be awarded to L1. Thereafter, the lowest bidder among the local suppliers, shall be invited to match the L1 price for the remaining 50% quantity , subject to the local supplier's quoted price falling within the margin of purchase preference, and the order for that quantity shall be awarded to such local supplier subject to matching the L1 price. In case such lowest eligible local supplier fails to match the L1 price or accepts less than offered quantity, the next higher local supplier within the margin of purchase preference shall be invited to match the L1 price for remaining quantity and so on, and the order shall be awarded accordingly. In case some quantity is still left uncovered on local suppliers, then such balance quantity may also be ordered on the L1 bidder.
iii	If the procurement of goods are not covered by 23(B)(ii) and are not divisible in nature, and in procurement of services where the bid is evaluated on the price alone, the following procedure shall be followed :
a	If L1 is a local supplier, the order shall be awarded to local supplier
b	If L1 bid is not from a local supplier, then the lowest bidder among the local suppliers, will be invited to match the L1 price, subject to the local supplier's quoted price falling within the margin of purchase preference, and the order shall be awarded to such local supplier subject to matching the L1 price. In case such lowest eligible local supplier fails to match the L1 price, the local supplier with the next higher bid within the margin of purchase preference shall be invited to match the L1 price and so on, and the order shall be awarded accordingly. In case none of the local suppliers within the margin of preference match the L1 price, then the order may be awarded to the L1 bidder.
C	Exemption of small purchases
	Notwithstanding anything contained at clause 23B above, procurements where the estimated value of procurement is less than Rs 5 lakhs are exempt and purchase preference shall not be accorded in such cases.

D	Verification of local content
(i)	The local supplier, at the time of tender, bidding or solicitation, shall be required to provide self certification that the item offered meets the minimum local content and shall give details of the location(s) at which the local value addition is made.
(ii)	In cases of procurement for a value in excess of Rs 10 crores, the local supplier shall be required to provide a certificate from the statutory auditor or cost auditor of the company (in case of companies) or from a practicing cost accountant or practicing chartered accountant (in respect of suppliers other than companies) giving the percentage of local content.
(iii)	False declarations shall be in breach of code of integrity and shall invite action as per guidelines for Suspension of Business dealings with Suppliers
E	In case of any disputes / clarifications, the extant guidelines of Government of India shall prevail.
24	Fraud Prevention
	The Bidder along with its associate/ collaborators/ sub-contractors/ sub-vendors/ consultants/ service providers shall strictly adhere to BHEL Fraud Prevention Policy displayed on BHEL website http://www.bhel.com and shall immediately bring to the notice of BHEL Management about any fraud or suspected fraud as soon as it comes to their notice
25	Settlement of Disputes & Arbitration
A	All questions/interpretations regarding subject matter of the Contract shall be decided by the Purchaser on the request of the Seller and the decision of the Purchaser shall be final.
B	In case of dispute, steps shall be taken by the parties to the contract to settle the same through negotiations.
C	In case, dispute is not settled in negotiations, it shall be referred to Conciliator appointed by the competent authority of the Purchaser.
D	In case dispute is not settled in conciliation proceedings, the same shall be referred to Arbitration as per Corporate Guidelines of the Purchaser and the arbitration proceeding shall be conducted as per provisions of the Arbitration and Conciliation Act, 1996 read with Corporate guideline as amended from time to time.
E	The Seller shall continue to perform the contract, pending settlement of dispute(s).
26	Applicable Laws and Jurisdiction of Courts
	Indian laws both substantive and procedural, for the time being in force, including modifications thereto, shall govern the Contract including Arbitration proceedings. The competent Courts at Jhansi in the State of Uttar Pradesh, India shall have sole jurisdiction.
27	Conciliation
	BHEL and bidder agree that if at any time (whether before, during or after the arbitral or judicial proceedings), any Disputes (which term shall mean and include any dispute, difference, question or disagreement arising in connection with construction, meaning, operation, effect, interpretation or breach of the terms and conditions of order, which the Parties are unable to settle mutually), arise inter-se the Parties, the same may, be referred by either party to Conciliation to be conducted through Independent Experts Committee to be appointed by competent authority of BHEL from the BHEL Panel of Conciliators. Notes: 1. No serving or a retired employee of BHEL/Administrative Ministry of BHEL shall be included in the BHEL Panel of Conciliators. 2. Any other person(s) can be appointed as Conciliator(s) who is/are mutually agreeable to both the parties from outside the BHEL Panel of Conciliators. The proceedings of Conciliation shall broadly be governed by Part-III of the Arbitration and Conciliation Act 1996 or any statutory modification thereof. The details of Conciliations shall be governed by the BHEL Conciliation scheme 2018.
28	General
	The Bidder shall keep a track of any changes by visiting the Supplier Information Portal of BHEL, Jhansi at https://www.bheljhs.co.in/apps/sip/index.php