



Bharat Heavy Electricals Limited
(A Govt. Of India Undertaking)
PROJECT ENGINEERING MANAGEMENT
NOTICE INVITING TENDER (NIT)

Enquiry No- PE/PG/NTF/E-6902/2021

Date- 5-Mar-22

BHEL invites offers from reputed bidders as per following terms and conditions -

1. Mode of Enquiry	E - PROCUREMENT	
2. Project	2X500 MW NTPLTUTICORIN FGD	
3. End Customer	NLC TAMILNADU POWER LIMITED	
4. Executing Agency	BHEL-PSSR	
5. Package	COMPRESSED AIR SYSTEM	
6. Due Date & Time	15 March 2022	11:00 AM IST
7. Earnest Money Deposit (EMD)	NIL	
8. Security Deposit (SD)	NIL	
9. Tender Cost	NIL	
10. Numbers of Part bid	2-Part bid (Techno-commercial and price bid)	
11. Technical Scope	As per Technical specification No: PE-TS-483-555-A002 REV 00	
12. Last Date for Seeking Clarification	10 March 2022	
13. Schedule of Pre Bid Discussion	Pre-bid conference shall be arranged based on pre-bid queries received. The schedule of pre-bid meeting shall be intimated later.	
14. Prequalification Requirement	Financial PQR- YES	Technical PQR- YES
15. Delivery terms	FOR Site Despatch Station.	
16. Delivery Schedule :-		
For Supply (along with commissioning spares)	Within 10 months from the date of LOA. Drawing/ documents submission shall be as per Technical Specification.	
E&C	Within 04 (Four) months from the date of availability of front. Site front availability will be reckoned as the date when site informs vendor for mobilization of manpower & resources.	
O&M Services	Required personnel for O & M Services shall be deputed within 10 days from the date of intimation.	
17. Prices shall be Firm till completion of contract.	PVC Formula, If applicable :- NA	
18. CIF Content	Not Available	
19. Integrity Pact Applicability -	NO	
20. Tender Evaluation -	The evaluation currency for this tender shall be INR. Evaluation will be done on overall L1 (Total Cost to BHEL excluding GST) basis with necessary loading as applicable. In RA, the loading (technical/commercial), if any, shall be added by bidder while submitting the bid in reverse auction portal. Ordering shall be done after de-loading the commercial/ technical loading from bidder's final price. In the course of evaluation, if more than one bidder happens to occupy L-1 status, effective L-1 will be decided by soliciting discounts from the respective L-1 bidders. In case more than one bidder happens to occupy the L-1 status even after soliciting discounts, the L-1 bidder shall be decided by a toss/draw of lots, in the presence of the respective L-1 bidder (s) or their representative(s). Ranking will be done accordingly. BHEL's decision in such situations shall be final & binding.	
21. Terms & Conditions:-	The terms & conditions shall be as per enclosed special conditions of the contract (copy enclosed), GCC Rev 07 which is available on www.pem.bhel.com and other Terms and Conditions included in this Enquiry Letter.	
22. Bidders who fulfil Technical and Financial Pre-Qualification Requirement Criteria are eligible to participate in this tender. Bids of only those bidders shall be evaluated who meet the Technical & Financial Pre-Qualifying requirements.		
23. "BHEL shall be resorting to Price Bid Opening (PBO) for this tender. Price Bid Opening shall be conducted among all the techno-commercially qualified bidders.		
24. Regarding verification of PQR documents- Bidders to ensure that Third party/customer issued certificates being submitted as proof of PQR qualification should have verifiable details of document/certificate issuing authority such as name & designation of Issuing Authority and its organization contact number and e-mail Id etc. In case the same found not available, Purchaser has right to reject such document from evaluation.		



Bharat Heavy Electricals Limited
(A Govt. Of India Undertaking)
PROJECT ENGINEERING MANAGEMENT
NOTICE INVITING TENDER (NIT)

25. Bidder to note that this is an Open Tender enquiry & Price Bid Opening participation shall be subject to following condition:

- a) Qualifying Technical & Financial Pre-Qualification Requirement.
- b) Techno-commercial acceptance of offer by BHEL-PEM.

The bidders who are not registered with BHEL-PEM may apply for registration in BHEL-PEM through Registration Portal available at www.pem.bhel.com --> vendor section --> online supplier registration. All credentials and/or documents duly signed & stamped related to registration has to be uploaded on the website & submit the application for registration. One set of hard copy filled-up SRF downloaded from Online Registration Portal duly signed & stamped has to be submitted.

26. Scope of Construction water and construction power: - As per Annexure-I.

27. All corrigenda, addenda, amendments, time extensions, clarifications, etc. to the tender will be hosted on BHEL website (www.bhel.com), <https://eprocurebhel.co.in/nicgep/app> & BHEL-PEM website (www.pem.bhel.com). Bidders should regularly visit websites to keep themselves updated.

28. BG should be in favour of BHEL-PSSR in place of PEM. L1 Vendor will be required to submit BG as per GCC Rev-07.

29. Bidder agrees to submit the performance security required for execution of the contract within the time period mentioned. In case of delay in submission of performance security, enhanced performance security which would include interest (SBI rate + 6%) for the delayed period, shall be submitted by the bidder. Further, if performance security is not submitted till such time the first bill becomes due, the amount of performance security due shall be recovered as per terms defined in NIT / contract, from the bills along with due interest.

30. If bidder mentions Not Applicable / Not required / Not Quoted in BHEL price format, the same to be substantiated by the bidder. If such item is required to be supplied for system completion in future, same will be supplied free of cost.

31. All other correspondence thereof shall be addressed to the undersigned by name & designation and sent at the following address:

Sanjeev Kumar / Dy. Engr, Gr-I – BOP
M/s Bharat Heavy Electricals Ltd.,
Project Engineering Management,
Power Project Engineering Institute,
HRD & ESI Complex,
Plot No 25, Sector-16 A, Noida-201301
E-MAIL: sanjeev_k@bhel.in
Ph. No. 0120-4368590

Upendra Chaudhary/Sr. MGR-BOP
M/s Bharat Heavy Electricals Ltd.,
Project Engineering Management,
Power Project Engineering Institute,
HRD & ESI Complex,
Plot No 25, Sector-16 A, Noida-201301
E-MAIL: upendrachaudhary@bhel.in
Ph. No. 0120-4213561

32. Variation in contract value for this package shall be +/-10% applicable in place of +/-30% mentioned in clause no. 6 of General Conditions of Contract of GCC rev-07.

33. Insurance Deductibles - Insurance Deductibles/Excess shall be as follows:

For Marine Cover:

0.25% of consignment value subject to minimum of Rs 20,000/-

For Storage /Erection and Testing Cover:

Normal Excess: 5 % of the claim amount subject to a minimum of Rs. 1.5 Lakh.

Testing Excess: 5% of the claim amount subject to minimum of Rs. 4.0 Lakh.

Act of God Perils: - 10% of the claim amount subject to minimum of testing period excess.

Fire / Explosion Claims: 20% of the claim amount subject to minimum of testing period excess

Third Party Liability:

The policy excesses (normal/testing periods) shall apply for third party liability property damage claims also.

For third party liability claims arising out of acts of GOD perils. The excess applicable to AOG claims shall apply.

Terrorism cover: - 5% of loss amount subject to minimum Rs. 1 Lakhs and Maximum 2 Crores 50 Lakhs EEL

"The above mentioned insurance deductibles/excess are tentative in nature and may change after award of contract which will be applicable within quoted price"

34. The Bidder declares that they will not enter into any illegal or undisclosed agreement or understanding, whether formal or informal with other Bidder(s). This applies in particular to prices, specifications, certifications, subsidiary contracts, submission or non-submission of bids or any other actions to restrict competitiveness or to introduce cartelization in the bidding process. In case, the Bidder is found having indulged in above activities, suitable action shall be taken by BHEL as per extant policies/ guidelines.



Bharat Heavy Electricals Limited
(A Govt. Of India Undertaking)
PROJECT ENGINEERING MANAGEMENT
NOTICE INVITING TENDER (NIT)

35. All Bidders to comply Govt. of India, Ministry of Power, order no-25-111612018-PG dtd 02/07/2020 regarding mandatory testing of all the imported items/equipment's/components.
36. GST shall be payable extra at actual as per the HSN code finalised for the items during detailed BBU.
37. In place of clause no 26 of (ITB) GCC-Rev-07, following clause to be considered:
"For this procurement, the local content to categorise a supplier as Class I local supplier/ Class II local supplier/ Non Local supplier and purchase preference to Class I local supplier is as defined in Public Procurement (Preference to Make India), Order 2017 dated 16.09.2020 issued by DPIIT.
In case of subsequent order issued by nodal ministry changing the definition of local content for item in NIT, the same shall be applicable even if issued after issue of this NIT but before opening of part-II bids against this NIT."
This package is not divisible in nature. The margin of purchase preference shall be as per order dtd. 04.06.2020. For this tender, offer from class-1 local suppliers (meeting minimum 50% local content requirement) shall be considered.
Bidders are required to provide the following along with the part-1 bid:
(i) Provide a self-certificate **(in line with attached draft)** meeting minimum local content requirement for class-1 supplier (50%).
(ii) Provide the details of the location(s) at which the local value addition shall be made.
38. This item/Package falls under the list of items defined in Para 3 of Ministry guideline ref no.F.20/2/214-PPD(Pt.) dated.20-09-2016 (in respect of procurement of items related to public safety, health, critical security operations and equipment's, etc) & hence no relaxation of PQR for start-up/MSME vendors is envisaged for the NIT items/Package"
39. Minimum E&C Charges shall be 10% instead of 20% as mentioned in Clause No 3.0 (Instruction to Bidders) of GCC Rev-07
40. Due to COVID-19 pandemic, BHEL may go for Remote Inspection of Offered items, if required. Vendors are requested to be equipped with the facilities/gadgets as indicated in the guidelines available at : <https://pem.bhel.com/Documents/VendorSection/Vendor/Guidelines.pdf> .
41. Bidders may visit site/ work area and study the job content, facilities available, availability of materials, prevailing site conditions including law & order situation etc. before quoting for this tender. They may also consult this office before submitting their offers, for any clarifications regarding scope of work, facilities available at sites or on terms and conditions. No additional claim shall be entertained by BHEL in future, on account of non-acquaintance of above.
42. Restrictions under Rule 144(xi) of the General Financial Rules (GFRs), 2017
- I. Any bidder from a country which shares a land border with India will be eligible to bid in this tender only if the bidder is registered with the Competent Authority.
- II. "Bidder" (including the term 'tenderer', 'consultant' or 'service provider' in certain contexts) means any person or firm or company, including any member of a consortium or joint venture (that is an association of several persons, or firms or companies), every artificial juridical person not falling in any of the descriptions of bidders stated hereinbefore, including any agency branch or office controlled by such person, participating in a procurement process.
- III. "Bidder from a country which shares a land border with India" for the purpose of this Order means
- a. An entity incorporated, established or registered in such a country; or
- b. A subsidiary of an entity Incorporated. established or registered in such a country; or
- c. An entity substantially controlled through entities incorporated, established or registered in such a country; or
- d. An entity whose beneficial owner is situated in such a country: or
- e. An Indian (or other) agent of such an entity; or
- f. A natural person who is a Citizen of such a country; or
- g. A consortium or joint venture where any member of the consortium or joint venture falls under any of the above.
- IV. The beneficial owner for the purpose of (iii) above will be as under:
1. In case of a company or Limited Liability Partnership, the beneficial owner is the natural person(s), who, whether acting alone or together, or through one or more juridical person, has a controlling ownership Interest or who exercises control through other means,
- Explanation-
- a. "Controlling ownership interest" means ownership of or entitlement to more than twenty-five per cent. of shares or capital or profits of the company;



Bharat Heavy Electricals Limited
(A Govt. Of India Undertaking)
PROJECT ENGINEERING MANAGEMENT
NOTICE INVITING TENDER (NIT)

- b. "Control" shall include the right to appoint majority of the directors or to control the management or policy decisions Including by virtue of their shareholding or management rights or shareholder's agreements or voting agreements;
2. In case of a partnership firm, the beneficial owner is the natural person(s) who, whether acting alone or together. or through one or more juridical person, has ownership of entitlement to more than fifteen percent of capital or profits of the partnership;
3. In case of an unincorporated association or body of individuals, the beneficial owner is the natural person(s), who, whether acting alone or together, or through one or more juridical person, has ownership of or entitlement to more than fifteen percent of the property or capital or profits of such association or body of Individuals;
4. Where no natural person is Identified under (1) or (2) or (3) above, the beneficial owner is the relevant natural person who holds the position of senior managing official;
5. In case of a trust, the identification of beneficial owner(s) shall Include identification of the author of the trust. the trustee, the beneficiaries with fifteen percent or more interest in the trust and any other natural person exercising ultimate effective control over the trust through a chain of control or ownership.
- V. An Agent is a person employed to do any act for another, or to represent another in dealings with third person
- VI. The successful bidder shall not be allowed to sub-contract works to any contractor from a country which shares a land border with India unless such contractor is registered with the Competent Authority.
- Note- The above clause shall not be applicable for the bidders from those countries (even if sharing a land order with India) to which the Government of India (GoI) has extended lines of credit or in which the GoI is engaged in development work.

Bidders to submit the certification (**format enclosed**) as per Order no-F6/18/2019-PPD dated 23.07.2020 issued by Ministry of Finance.

43. All the above terms and conditions, post-bid agreements/MoMs (during Techno- Commercial evaluation) shall automatically become a part of the Order/Contract after its finalisation.

44. Bidders to note that offers shall be submitted strictly in accordance with the requirements of tender documents. Bidders shall upload their complete offer meeting the requirements of the tender documents on e-procurement portal <https://eprocurebhel.co.in/nicgep/app>.

Following documents need to be uploaded:

- Offer forwarding/ Covering letter with Un-price bid, Annexure-II (Cost of Withdrawal of Deviation)
- Documents required for meeting Technical & Financial PQRs
- Local content certificate in line with Make in India Order dated 16.09.2020.
- Certificate as per Order no-F6/18/2019-PPD dated 23.07.2020 issued by Ministry of Finance.
- Price bid along with Annexure-II on e-procurement portal - <https://eprocurebhel.co.in/nicgep/app>

45. It shall be the responsibility of the bidder to ensure that the tender is uploaded on or before the due date and time. Late offers are not accepted. Part-I bids shall be opened at 04:00 PM on due date through e-procurement Portal.

Note - In case you are not making an offer against this enquiry, you are requested to send a regret letter so as to reach us on or before the due date

Thanking You.
For and on behalf of BHEL

Digitally signed by UPENDRA CHAUDHARY
DN: c=IN, o=BHARAT HEAVY ELECTRICALS LIMITED,
ou=PS PEM, postalCode=201301, st=Uttar Pradesh,
2.5.4.20=9ae92814d1167bfa18bea4c9c2ce391b82767
31139d007915dbf62a123dc9f, cn=UPENDRA
CHAUDHARY
Date: 2022.03.05 14:47:15 +05'30'

Upendra Chaudhary
Sr. Manager/BOP

Enclosures: - (1) SCC of the Project (2) Financial PQR (3) Technical Specifications (4) Technical PQR (5) BOQ/Price Format (6) Draft format for Make in India certificate and land border certificate



**PRE-QUALIFICATION REQUIREMENT –
COMPRESSED AIR SYSTEM**

DATE	01/03//2022
REV NO	00

1.0	<p>The bidder is required to meet the provneness criteria and / or qualification requirement for Compressed Air System package as per criteria stipulated below:</p> <p>The bidder should have designed, manufactured, supplied and erection & commissioning of at least One (1) number Oil free screw type air compressor of capacity not less than 9 Nm³/min. at rated discharge pressure of 8.5 kg/cm² (g) which should have been in successful operation for at least One (1) year as on date of bid opening.</p>
2.0	<p>The supplier has to submit following supporting documents meeting above mentioned pre-qualifying requirement</p> <p>Copy of one (1) performance certificate in English from end user along with copy of related Purchase Order (PO) or letter of intent (LOI) or letter of award (LOA) or work order (WO) in support of PQR clause mentioned at S. No. 1.0 above.</p>
3.0	<p>Bidder shall submit other relevant documents to substantiate technical parameters specified in PQR, if the same is not mentioned in performance certificate/purchase order.</p>
4.0	<p>Minimum one (1) no. Purchase order shall be submitted which should not be more than seven (7) years old as on date of bid submission, for establishing continuity in business. This is over and above the requirement of PO mentioned at S. No. 2.0 above.</p>
5.0	<p>Bidder to submit all supporting documents in English. If documents submitted by bidder are in language other than English, a self-attested English translated document should also be submitted.</p>
6.0	<p>Notwithstanding anything stated above, BHEL reserves the right to assess the capabilities and capacity of the bidder/ collaborator to perform the contract, should the circumstances warrant such assessment in the overall interest of BHEL.</p>
7.0	<p>Consideration of offer shall be subject to customer's approval of bidder, if applicable.</p>
8.0	<p>After satisfactory fulfilment of all the above criteria/ requirement, offer shall be considered for further evaluation as per NIT and all other terms of the tender.</p>
9.0	<p>The bidder shall meet PQR based on its own credentials. Bid from joint venture (JV) company / Consortium bid is not acceptable.</p>



PRE - QUALIFYING REQUIREMENTS

ENQUIRY NO:	PE/PG/NTF/E-6902/2021 Dated 05.03.2022
PROJECT:	TUTICORIN-FGD
PACKAGE:	COMPRESSED AIR SYSTEM

CRITERIA FOR EVALUATION - FINANCIAL :

Average annual financial turnover during the last Three Financial Years should not be less than
Rupees Fifty Four Lakh(s) Only

Amount (in Rs.)
Rs.54,00,000.00

Notes:-

a) The bidder has to submit financial accounts (audited, if applicable comprising of Audit report, Balance Sheet, Profit & Loss A/c Statement and Notes/Schedules pertaining to Turnover/Sales/Revenue), for last three years (or from the date of incorporation, whichever is less) as on tender due date to review the above criteria. In case the incorporation of vendor is less than 3 years, average annual financial turnover shall be calculated based on available information as below:-

i) If the accounts are available for ≤ 1 Financial Year, the Average Annual Turnover shall be calculated based on available information divided by 1 (One).

ii) If the accounts are available for >1 but ≤ 2 Financial Years, the Average Annual Turnover shall be calculated based on available information divided by 2 (Two).

iii) If the accounts are available for >2 but ≤ 3 Financial Years, the Average Annual Turnover shall be calculated based on available information divided by 3 (Three).

b) Foreign bidder is to submit a latest report from reputed third party business rating agency like Dun & Bradstreet, Credit reform etc. in addition to the documents mentioned at point (a) above for review of above criteria.

c) Other Income shall not be considered for arriving at Annual Turnover/Sales. For evaluation purpose, Turnover figure excluding taxes shall be considered.

d) For evaluation of foreign bidder, exchange rate (TT selling rate of SBI) as on scheduled date of tender opening (Part-I bid in case of two part bid) shall be considered.

NTPL TUTICORIN - FGD (2 X 500 MW)

OF

NTPL (NLC TAMILNADU POWER LTD)
(Joint venture of TANGEDCO and NLC India Limited. Enterprise)

TECHNICAL SPECIFICATION FOR COMPRESSED AIR SYSTEM

SPECIFICATION NO.: PE-TS-483-555-A002



**BHARAT HEAVY ELECTRICALS LIMITED
POWER SECTOR
PROJECT ENGINEERING MANAGEMENT
NOIDA (INDIA)**



2X500 MW NTPL TUTICORIN FGD

COMPRESSED AIR SYSTEM

SPECIFICATION NO: PE-TS-483-555-A002

VOLUME: II B & III

REV: 00

DATE: FEB 2022

SHEET: 1 OF 1

VOLUME – IIB

SECTIONS	TITLE	Page No
SECTION-A	INTENT OF SPECIFICATION	3
SECTION-B	PROJECT INFORMATION WITH WIND AND SEISMIC DESIGN CRITERIA	6
SECTION-C	TECHNICAL SPECIFICATIONS	
SECTION-C1	SCOPE OF SUPPLY & SERVICES, TERMINAL POINTS, EXCLUSIONS AND OTHER PROJECT SPECIFIC DETAILS	11
SECTION-C2	CUSTOMER SPECIFICATION	
C2 - A	TECHNICAL REQUIREMENT	20
C2 - B	PROJECT SPECIFIC GENERAL REQUIREMENTS	73
C2 - C	PERFORMANCE GUARANTEE TESTS	145
C2 - D	QUALITY ASSURANCE	156
SECTION-C3	TECHNICAL SPECIFICATION (ELECTRICAL PORTION)	173
SECTION-C4	TECHNICAL SPECIFICATION (C&I PORTION)	220

SECTION-E	ANNEXURE-I	LIST OF MAKES OF SUB-VENDOR ITEMS	312
	ANNEXURE-II	PAINTING & COLOUR SCHEME	335
	ANNEXURE-III	MASTER DRAWING LIST WITH SCHEDULE OF SUBMISSION	370
	ANNEXURE-IV	SITE STORAGE AND PRESERVATION	372
	ANNEXURE-V	PACKING PROCEDURE	388
	ANNEXURE-VI	LIST OF OPERATIONAL SPARES	420

VOLUME-III

SECTIONS	TITLE	Page No
1	LIST OF DOCUMENTS TO BE SUBMITTED WITH BID	423
2	COMPLIANCE CUM CONFIRMATION CERTIFICATE	425
3	PRE BID CLARIFICATION SCHEDULE	428
4	ELECTRICAL LOAD DATA	430
5	LIST OF DRAWINGS	
	DRG TITLE	DRG NO
	A SCHEMATIC DRAWING OF COMPRESSED AIR SYSTEM	0011-109-POM-A-006
	B COMPRESSOR HOUSE LAYOUT	PE-DG-483-555-A001
6	GUARANTEED POWER CONSUMPTION FOR COMPRESSED AIR SYSTEM	435
7	ANNUAL MAINTENANCE CONTRACT	437-439.

714945/2022/PS-PEM-MAX



2X500 MW NTPL TUTICORIN FGD

COMPRESSED AIR SYSTEM

SPECIFICATION NO: PE-TS-483-555-A002

VOLUME: II B

SECTION: A

REV: 00

DATE: FEB 2022

Sheet: 1 OF 3

SECTION-A

INTENT OF SPECIFICATION

	2X500 MW NTPL TUTICORIN FGD	SPECIFICATION NO: PE-TS-483-555-A002	
	COMPRESSED AIR SYSTEM	VOLUME: II B	
		SECTION: A	
		REV: 00	DATE: FEB 2022
		Sheet: 2 OF 3	

1.0 INTENT OF SPECIFICATION

- 1.1 The specification is intended to cover design, engineering, manufacture, inspection and testing at vendor's/ sub-vendor's works, painting, forwarding, proper packing and shipment and delivery at site, unloading, handling & transportation at site, Erection & Commissioning, minor civil works as required on FOR site basis, Performance and guarantee testing, handing over of Compressed Air System and AMC for one year as per details in different sections / volumes of this specification for **2X500 MW NTPL TUTICORIN FGD**.
- 1.2 The contractor shall be responsible for providing all material, equipment & services, which are required to fulfil the intent of ensuring operability, maintainability, reliability and complete safety of the complete work covered under this specification, irrespective of whether it has been specifically listed herein or not. Omission of specific reference to any component / accessory necessary for proper performance of the equipment shall not relieve the contractor of the responsibility of providing such facilities to complete the supply of Compressed Air System within quoted price.
- 1.3 It is not the intent to specify herein all the details of design and manufacturing. However, the equipment shall conform in all respects to highest standards of design, engineering and workmanship and shall be capable of performing the required duties in a manner acceptable to purchaser who will interpret the meaning of drawings and specifications and shall be entitled to reject any work or material which in his judgement is not in full accordance herewith.
- 1.4 The extent of supply under the contract includes all items shown in the drawings, notwithstanding the fact that such items may have been omitted from the specification or schedules. Similarly, the extent of supply also includes all items mentioned in the specification and /or schedules, notwithstanding the fact that such items may have been omitted in the drawing. Similarly, the extent of supply also includes all items required for completion of the system and not withstanding that they may have been omitted in drawings / specifications or schedules.
- 1.5 The general term and conditions, instructions to tenderers and other attachment referred to elsewhere are made part of the tender specification. The equipment materials and works covered by this specification is subject to compliance to all attachments referred to in the specification. The bidder shall be responsible for and governed by all requirements stipulated herein.
- 1.6 While all efforts have been made to make the specification requirement complete & unambiguous, it shall be bidders' responsibility to ask for missing information, ensure completeness of specification, to bring out any contradictory / conflicting requirement in different sections of the specification and within a section itself to the notice of BHEL and to seek any clarification on specification requirement in the format enclosed under Vol-III of the specification **within 10 days of receipt of tender documents**. In absence of any such clarifications, in case of any contradictory requirement, the more stringent requirement as per



2X500 MW NTPL TUTICORIN FGD

COMPRESSED AIR SYSTEM

SPECIFICATION NO: PE-TS-483-555-A002

VOLUME: II B

SECTION: A

REV: 00

DATE: FEB 2022

Sheet: 3 OF 3

interpretation of Purchaser / Customer shall prevail and shall be complied by the bidder without any commercial implication on account of the same. Further in case of any missing information in the specification not brought out by the prospective bidders as part of pre-bid clarification, the same shall be furnished by Purchaser/ Customer as and when brought to their notice either by the bidder or by purchaser/ customer themselves. However, such requirements shall be binding on the successful bidder without any commercial & delivery implication.

1.7 The bidder's offer shall not carry any sections like clarification, interpretations and /or assumptions.

1.8 Deviations, if any, should be very clearly brought out clause by clause in the enclosed schedule; otherwise, it will be presumed that the vendor's offer is strictly in line with NIT specification.

1.9 In case all above requirements are not complied with, the offer may be considered as incomplete and would become liable for rejection.

1.10 Unless specified otherwise in GCC, all through the specification, the word contractor shall have same meaning as successful bidder /vendor and Customer/ Purchaser/Employer will mean BHEL and /or NTPL including their consultant as interpreted by BHEL in the relevant context.



**2X500 MW NTPL TUTICORIN FGD
COMPRESSED AIR SYSTEM**

SPECIFICATION No: PE-TS-483-555-A002

VOLUME: II B

SECTION : B

REV. 00

DATE: FFEB 2022

SHEET : 1 OF 1

SECTION: B

**PROJECT INFORMATION WITH WIND AND SEISMIC DESIGN
CRITERIA**



CONTENT

CLAUSE NO.	DESCRIPTION	PAGE NO.
1.00.00	INTRODUCTION	1
2.00.00	APPROACH TO SITE	1
3.00.00	LAND	1
4.00.00	SOURCE OF FUEL	1
5.00.00	SOURCE OF WATER	2
6.00.00	ASH DISPOSAL AREA	2
7.00.00	METEOROLOGICAL DATA	2





VOLUME : II-A

SECTION-II

PROJECT SYNOPSIS AND GENERAL INFORMATION

1.00.00 INTRODUCTION

NLC Tamil Nadu Power Limited (NTPL) is presently operating a thermal power plant having two units of 500 MW capacity each, in Tuticorin, Tamil Nadu.

The Bidder shall acquaint himself with the conditions prevailing at site by a visit to the site, before submission of the bid. The information given here in under is for general guidance and shall not be contractually binding on the Owner. All relevant site data /information as may be necessary shall have to be obtained/ collected by the Bidder.

2.00.00 APPROACH TO SITE

The site is accessed by National Highway No. 7A adjacent to plant. Due South connecting Madurai. The nearest railway station is Port Trust Railway Yard at a distance of 1.0 km. Tuticorin sea port is located adjacent to the plant. Nearest airstrip is located at Pudukottai at a distance of 16.5 km. Nearest town is Tuticorin, which is located 5.5 km away from the plant and nearest city is Pallayamkottai, away from 60 km from the plant.

3.00.00 LAND

The site encompasses about 108 Ha, which is located at Tuticorin Taluk in Tuticorin district in the Southern Part of Tamil Nadu along the Bay of Munnar.
Latitude : 8⁰45'38.09"N
Longitude : 78⁰10'15.85"E

The natural land profile of the site 1.46 m above mean sea level.

4.00.0 SOURCE OF FUEL

The primary fuel for this plant is Coal. The Power plant will use coal from Talabira Mines and imported coal.

The daily coal requirement for 2x500 MW units is about 15360 tonnes (at TMCR). Annual coal requirement for the plant is around 4.48 MTPA.





5.00.00 SOURCE OF WATER

Main source of water of the plant is sea water, which shall be taken from the Bay of Munnar. The existing 2x 500 MW NTPL Tuticorin plant uses sea water based closed cooling system with Natural Draft Cooling Towers (NDCT). The sea water intake system comprises of gravity intake channels of a capacity 15000 m³/hr. Out of this, around 9000 m³/hr is fed as cooling tower makeup water through CT makeup pumps (2W+1S). Around 3000 m³/hr sea water is utilized in the RO plant for utilization as service water, potable water, power cycle makeup and miscellaneous uses. The blow down from the Cooling tower back to sea is around 7000 m³/hr.

6.00.00 ASH DISPOSAL AREA

Fly ash is taken by consumer for further utilization. Balance ash is disposed off by HCSD method to the ash dumping area.

7.00.00 METEOROLOGICAL DATA

7.01.00 For the purpose of equipment design, the following Meteorological data of site (as per IMD Tuticorin) shall be taken into consideration

- | | | | |
|----|-----------------------------|---|--|
| a) | Ambient temperature | : | 36.5 °C maximum
20.8 °C minimum |
| b) | Extreme Ambient temperature | : | 36.4 °C maximum (Annual)
24.1 °C minimum (Annual) |
| d) | Relative humidity | : | |
| | (i) Maximum | | 82% |
| | (ii) Minimum | | 35% |
| | (iii) Average | | 57 to 68% |
| e) | Annual Rainfall | : | 437 mm |
| f) | Wind load | : | In accordance with IS-875, Part-3 |
| g) | Seismic Zone | : | Zone II as per IS: 1893 latest edition. |
| h) | Altitude | : | 1.46 M above MSL |

714945/2022/PS-PEM-MAX

	2X500 MW NTPL TUTICORIN FGD COMPRESSED AIR SYSTEM	SPECIFICATION No: PE-TS-483-555-A002	
		VOLUME: II B	
		SECTION : C	
		REV. 00	DATE: FEB 2022
		Sheet: 1 of 1	

SECTION: C

TECHNICAL SPECIFICATIONS

	2X500 MW NTPL TUTICORIN FGD COMPRESSED AIR SYSTEM	SPECIFICATION No: PE-TS-483-555-A002	
		VOLUME: II B	
		SECTION : C1	
		REV. 00	DATE: FEB 2022
		Sheet: 1 OF 1	

SECTION: C1

SPECIFIC TECHNICAL REQUIREMENT

	2X500 MW NTPL TUTICORIN FGD COMPRESSED AIR SYSTEM	SPECIFICATION No: PE-TS-483-555-A002	
		VOLUME: II B	
		SECTION : C1	
		REV. 00	DATE: FEB 2022
		SHEET 1 OF 1	

VOLUME - II B

SECTION: C1

SCOPE OF SUPPLY & SERVICES, TERMINAL POINTS, EXCLUSIONS AND OTHER PROJECT SPECIFIC DETAILS

	2X500 MW NTPL TUTICORIN FGD COMPRESSED AIR SYSTEM	SPECIFICATION No: PE-TS-483-555-A002	
		VOLUME - IIB	
		SECTION C1	
		REV.00	DATE: FEB 2022
		SHEET: 1 OF 6	

1. SCOPE OF WORK:

The specification covers Supply part and Services part comprising of design (i.e. preparation and submission of drawing /documents including "As Built" drawings and O&M manuals), engineering, manufacture, fabrication, assembly, inspection / testing at vendor's & sub-vendor's works, painting, maintenance tools & tackles, fill of lubricants & consumables, along with spares for erection, start up and commissioning as required, forwarding, proper packing, shipment and delivery at site, unloading, handling, transportation & storage at site, in-site transportation, assembly, erection & commissioning, final painting at site, minor civil work, trial run at site, preparation of layout drawings and carrying out Performance guarantee tests at site, training of customer/client and O&M staff, handover in flawless condition of the package to the end customer complete with all accessories for the total scope defined as per BHEL NIT & tender technical specification, amendment & agreements till placement of order and AMC for one year for 2X500 MW NTPL TUTICORIN FGD

Items not specifically mentioned but deemed necessary by the Tenderer for making the system completely reliable and efficient shall also be considered as if included.

2. SCOPE OF SUPPLY:

Scope of supply by bidder shall include but not limited to the following:

- 2.1 Two (2) Nos. Air Compressors (Oil Free Screw type) each of minimum 9.0 NM³/Min capacity at 8.5 Kg/cm² (g) discharge pressure, along with motor, suction filter with silencer, inter cooler and after cooler with moisture separators, automatic drain traps, instruments, control system and other accessories.

The compressors capacity will be designed for 36.5 deg. C DBT and 82 % RH at atmospheric pressure at site & at MSL of 1.46 M.

- 2.2 Two (2) Nos. Air Drying Plants Heat of Compression (HOC) - Rotary / Twin tower type of matching capacity of air compressor along with all instruments, control panels and other accessories as specified.

- 2.3 Two (2) nos. air receivers, each of capacity, 6.5 cu.m or as derived from the formula given under Cl. No. 4.13.00, SECTION: C2-A, VOLUME: II B, whichever is higher. Air receivers are located near the compressor house building.

- 2.4 Sequential panel (as per OEM standard) for ensuring equal no. of running hours of each compressor – 1 Lot.

- 2.5 Two (2) nos Online Electronic Dew point meter (one after each drying plant).

- 2.6 Pipes & fittings for compressed air line, cooling water & drain line including hanger/supports, auxiliary structural members etc. inclusive of all fittings, flanges & Counter flanges, bolts, nuts, gaskets etc. at all piping terminals.

- 2.7 All airline valves, cooling water valves, drain valves etc.– 1 Lot.

- 2.8 Necessary instruments for control and interlocks, instruments indicated in the P&I Diagram for the compressed air system to be considered as a minimum. Any other instrument(s) required as per section C of Technical specification shall also be provided.

- 2.9 Access platform required for the maintenance of instruments/valves on the towers of HOC type air drier, air receiver, if required, shall be provided by successful bidder's.

	2X500 MW NTPL TUTICORIN FGD COMPRESSED AIR SYSTEM	SPECIFICATION No: PE-TS-483-555-A002	
		VOLUME - IIB	
		SECTION C1	
		REV.00	DATE: FEB 2022
		SHEET: 2 OF 6	

- 2.10 Maintenance tools and tackles, consumables, first fill of lubricants inclusive of packing – 1 Lot.
- 2.11 Commissioning spares with proper packing suitable for long duration storage – 1 Lot (refer Annexure-VI).
- 2.12 Compressor & Dryer mounted local control panel.
- 2.13 Erection, start up and commissioning consumable & spares as required for completing these activities.
- 2.14 All flanges, fasteners and counter flanges at all TPs.
- 2.15 Pipe supporting structure over the insert plate for pedestal supported pipe, wall supported pipe, insert plate and supporting structure for floor supported pipe.
- 2.16 All Equipment base plate, foundation anchor bolts.
- 2.17 Paint required for painting of all items under the package for corrosion protection and to meet color coding required by customer.
- 2.18 Any other item mentioned under NTPL specification and enclosed under Section SECTION-C2 of this Specification
- 2.19 Any other item covered under the price format.
- 2.20 Electrical scope as per details furnished under Section – C3: TECHNICAL SPECIFICATION (ELECTRICAL PORTION).
- 2.21 Instrumentation & control System including instruments, interlocking & protection devices with bare minimum instrumentation as shown in P&I Diagram of Compressed Air System (FLOW DIAGRAM – COMPRESSED AIR SYSTEM (WITHIN COMPRESSOR HOUSE), VOL III, Section V) and any other instruments required for safe, efficient and reliable operation of the system and to be read in conjunction with C&I portion of specification (Refer Section – C4).
- 2.22 Any other item required for making the installation complete in all respect and for satisfactory operation of the system , meet layout and accessibility & operability requirements for the scope within the terminal point , for compliance to GTR (General Technical Requirement), GCC (General Condition of Contract) , SCC (Special Condition of Contract), ECC (Erection condition of contract) as relevant to Compressed Air System as well as to meet any statutory requirement relevant to the package, unless specifically EXCLUDED from scope of supply.

3. SCOPE OF SERVICES:

Scope of services by bidder shall include but not necessarily limited to the following:

- 3.1 Erection & Commissioning of Compressed Air System.
- 3.2 Unloading, Storage, handling and transportation at site (Pl. refer Section-E, Annexure - IV).
- 3.3 Pre- Commissioning work such as flushing, hydraulic testing etc. Necessary consumables and instrumentation as required for inspection and testing at works as well as at site including pre-commissioning activities shall be arranged by the successful bidder at their own cost.
- 3.4 Performance Guarantee test (Refer Section C2-C).
- 3.5 Painting of all items within bidder's scope of supply equipment within the battery limit.

	2X500 MW NTPL TUTICORIN FGD COMPRESSED AIR SYSTEM	SPECIFICATION No: PE-TS-483-555-A002	
		VOLUME - IIB	
		SECTION C1	
		REV.00	DATE: FEB 2022
		SHEET: 3 OF 6	

- 3.6 Electrical scope as per enclosure elsewhere in the specification.
- 3.7 Preparation of drawing showing common facilities, if any, between BHEL & Vendor supplied equipment.
- 3.8 Supply of temporary equipment and services for Erection, commissioning and test etc. as applicable.
- 3.9 Making good/ repairing/ replacement of any damage done by the bidder to adjacent structures, pipes, etc. while erecting and commissioning equipment related to Compressed Air System
- 3.10 Site support during DCS commissioning.
- 3.11 Any other services mentioned under NTPL specification and enclosed under SECTION-C2 of this Specification.
- 3.12 Any other service covered under the price format.
- 3.13 Preparation of civil assignment drawings i.e. pedestals details, insert plates / embedment's plates required for supporting pipes and equipment etc. and review of civil drawing prepared by customer based on civil assignment drawing of bidder. In case any modification is required in the civil work already done based on civil inputs given by vendor, rework shall be done at the cost and risk of the vendor.
- 3.14 Training of plant Owner's personnel, O&M operators' personnel on plant and Equipment operation and maintenance.
- 3.15 Any other services required for making the installation complete in all respect and for satisfactory operation of the system , meet layout and accessibility & operability requirements for the scope within the terminal point , for compliance to GTR (General Technical Requirement), GCC (General Condition of Contract) , SCC (Special Condition of Contract), ECC (Erection condition of contract) as relevant to Compressed Air System as well as to meet any statutory requirement relevant to the package, unless specifically EXCLUDED from scope of supply.
- 3.16 Annual maintenance contract for one year from the date of handover of the complete system to the end customer or as agreed mutually with the construction manager and the successful bidder. AMC scope covers all regular maintenance by certified and trained service engineers. Spares and consumables required during AMC period shall be provided to Bidder's service provider by BHEL on the written request basis. Any specific item not available in BHEL inventory, shall be provided by Bidder on mutual settlement of related commercial issues.

4. EQUIPMENT SELECTION & DESIGN CRITERIA

The minimum design criteria/ technical details to be followed for various equipment shall be as per Data Sheets / Design criteria under Section – C2 including NTPL specification and other details placed elsewhere in the specification. In case of any contradictory requirement for specification of particular equipment, and clarifications not having been sought by the bidders, the most stringent requirement as per interpretation of the BHEL will prevail. Successful bidder will furnish detailed data sheets/ specifications / design calculations for various equipment for customer's/ consultant's approval during detail engineering. For items for which specific technical specification is not enclosed, data sheet / dwgs / design calculations for such items shall be subject to customer/ consultant approval during detail engineering. All comments made by customer/ consultant shall be incorporated by the successful bidder without any commercial and delivery implication.

	2X500 MW NTPL TUTICORIN FGD COMPRESSED AIR SYSTEM	SPECIFICATION No: PE-TS-483-555-A002	
		VOLUME - IIB	
		SECTION C1	
		REV.00	DATE: FEB 2022
		SHEET: 4 OF 6	

5. TERMINAL POINTS:

- 1.1 Bidder shall terminate compressed air piping, common for IA and SA at outlet of air receiver, approx. 5M away from vicinity of Compressor house.
- 1.2 Cooling water supply will be provided by the purchaser outside the compressor house (5m within vicinity of Compressor house). The return hot water shall be terminated by the contractor at the same location. Parameters at T.P. shall be as below:
 INLET TEMP. TO PHE :38 °C
 DESIGN PRESSURE = 10 KG/SQ.CM(G)
 Pipe Size at cooling water T.P. = 80 NB (both for inlet & outlet)
- 1.3 All the drains shall be terminated to plant garland drain outside compressor house by bidder.

6. EXCLUSIONS:

- 6.1 Spares / components required for AMC.
- 6.2 MCC / Switchgear for power supply to Air Compressors and other drives and panels.
- 6.3 Civil works like construction of compressor house, foundation of all compressor, air dryer and air receiver, pipe/cable trenches.
- 6.4 Lighting and ventilation of compressor house.
- 6.5 Fire protection & Detection system of Compressor House.
- 6.6 Monorail with Electric Hoists as necessary for handling of equipment after erection.
- 6.7 DCS control. However, all logic for implementation of control and monitoring from DCS shall be provided by successful bidder during detail engineering.
- 6.8 Relevant exclusion as per GTR, GCC, SCC & ECC.
- 6.9 Exclusions, if any, indicated in Electrical and C&I portion of the technical specification.

7. SERVICES TO BE PROVIDED BY THE CUSTOMER

Relevant services as per GCC, SCC & ECC.

8. PERFORMANCE GUARANTEES

Performance test for CAS shall be carried as per Section – C2-C.

All consumable and instruments required during PG Test will be arranged by the bidder. Instruments will be duly calibrated from customer authorised/ approved laboratory.

9. QUALITY ASSURANCE, QUALITY PLANS, INSPECTION & TESTING PROCEDURE

For Quality assurance, Quality Plans and Inspection & Testing, pl. refer Section – C2-D.

	2X500 MW NTPL TUTICORIN FGD COMPRESSED AIR SYSTEM	SPECIFICATION No: PE-TS-483-555-A002	
		VOLUME - IIB	
		SECTION C1	
		REV.00	DATE: FEB 2022
		SHEET: 5 OF 6	

The quality requirements specified are only indicative, any additional test, as required by NTPL shall be provided by bidder without any commercial and delivery implication to BHEL.

10. SUB-VENDOR ITEMS

The make of Sub-vendor items shall be generally as per enclosed sub vendor list, which is subject to NTPL approval during detail engineering (Refer section E/ Annexure-I).

Make of any unlisted items shall be subject to NTPL approval during detail engineering. For such items, bidder to furnish list of sub-vendors during detail engineering stage for BHEL's review and approval. Bidder shall furnish the following supporting documentation within 1 month of placement of LOI. Thereafter no request for additional sub-vendor shall be entertained.

- a) Documentation to show that the equipment /system has been supplied for a plant of similar or higher capacity.
- b) Documentation in the form of certificate that the equipment/system has been operating satisfactorily for one year.

The successful bidder will get the makes of all items approved from Customer/ Consultant during detail engineering within two months of placement of LOI. The complete list of sub vendors will necessarily be submitted by the successful bidder within one month of placement of LOI.

Bidder to assess the capability of their proposed sub-vendors in terms of preparation of drawings, calculations, documents, quality assurance, supply of material etc. as per project schedule before placing the order on them.

Dealers are not acceptable for any item of the package. Bidder shall procure all items including plates, structural, flanges, counter flanges etc. from approved sub vendor only.

11. DRAWINGS AND DOCUMENTS TO BE SUBMITTED WITH THE BID

The drawings and documents to be submitted with the bid shall strictly be as mentioned under Volume III (section-1). Any documents other than those indicated in Volume III (Section-1) will not be reviewed and will not form part of contract.

12. DRAWINGS/ DOCUMENTS REQUIRED DURING DETAIL ENGINEERING

Tentative list of drawing / document required during detail engineering is attached in Volume-II (Refer Section-E, Annexure-III). Any other drawings and documents as required by BHEL / Customer / Consultant shall be furnished by the successful bidder during detail engineering stage for which no commercial implication shall be entertained by BHEL.

13. DRAWINGS DISTRIBUTION SCHEDULE

Vendor needs to submit drawing/document during detail engineering along with editable soft copy of the same.

	2X500 MW NTPL TUTICORIN FGD COMPRESSED AIR SYSTEM	SPECIFICATION No: PE-TS-483-555-A002	
		VOLUME - IIB	
		SECTION C1	
		REV.00	DATE: FEB 2022
		SHEET: 6 OF 6	

14. ADDITIONAL POINTS TO BE NOTED BY BIDDER

- 14.1 Compressed Air system shall be offered as turnkey basis meeting specification requirements.
- 14.2 Basis of design, all calculations, equipment selection criterion, layout drawings/schemes/G.A. drg. and documents like data sheet/Technical particulars etc. are subject to Customer & BHEL approval during detail engineering stage.
- 14.3 All commissioning spares & consumables for trouble free operation shall be provided, with minimum to what specified elsewhere in the specification.
- 14.4 Performance test for compressors shall be carried out at shops with job motor only.
- 14.5 The outlet air temperature from air dryer in any case shall not be more than 45 deg. C. The Compressors coolers, dryer's coolers & / or after coolers shall be designed to withstand 10 kg/cm².
- 14.6 Minimum corrosion allowance of 2.5 mm shall be provided for air receiver.
- 14.7 Only KKS tagging shall be used in all document/drawings and in the field for all items/equipment/signals etc. No other tagging method is acceptable. The successful bidder shall provide detailed drawing with KKS only. Operational write up of the system should strictly contain KKS code for identification and description.
- 14.8 Packaging of items / equipment (Pl. refer Section-E, Annexure - V).
- 14.9 Inspection & testing (Refer Section C2-D).

15. LAYOUT CONSIDERATIONS

- 15.1 A separate Compressed Air System building, housing compressors with drives, air drying units, headers, piping, supports, valves etc. has been envisaged.
- 15.2 The air receivers will be located outdoors adjacent to the compressor room.

714945/2022/PS-PEM-MAX

**2X500 MW NTPL TUTICORIN FGD****COMPRESSED AIR SYSTEM**

SPECIFICATION No: PE-TS-483-555-A002

VOLUME: II B

SECTION : C2

REV. 00

DATE: FEB 2022

SHEET: 1 OF 1

SECTION: C2**CUSTOMER SPECIFICATIONS**

	2X500 MW NTPL TUTICORIN FGD COMPRESSED AIR SYSTEM	SPECIFICATION No: PE-TS-483-555-A002	
		VOLUME: II B	
		SECTION : C2-A	
		REV. 00	DATE: FEB 2022
		SHEET: 1 OF 1	

SECTION: C2-A

TECHNICAL REQUIREMENT



CONTENT

CLAUSE NO.	DESCRIPTION	PAGE NO.
1.00.00	INTRODUCTION	1
2.00.00	CODES AND STANDARDS	1
3.00.00	SYSTEM DESCRIPTION	3
4.00.00	SPECIFIC DESIGN CRITERIA AND PERFORMANCE REQUIREMENTS	3
5.00.00	SCOPE OF SUPPLY AND WORKS	7
6.00.00	DESIGN AND CONSTRUCTION	8
7.00.00	INSTRUMENTATION AND CONTROLS	16
8.00.00	INSPECTION AND TESTING	19
9.00.00	DRAWINGS/DOCUMENTS, DATA AND INFORMATION TO BE FURNISHED BY THE BIDDER ALONG WITH THE TECHNICAL OFFER	20
10.00.00	DRAWINGS DOCUMENTS, DATA AND MANUALS TO BE FURNISHED AFTER AWARD OF CONTRACT	20

ATTACHMENTS

ANNEXURE-II	DATA SPECIFICATION SHEET OF SCREW TYPE AIR COMPRESSOR AND AUXILIARIES	22
ANNEXURE-II	DATA SPECIFICATION SHEET OF AIR DRYING PLANT AND AUXILIARIES	30





VOLUME : II-H

SECTION-VII

COMPRESSED AIR SYSTEM

1.00.00 INTRODUCTION

This section covers design, constructional features, material requirement, manufacture, performance requirement, testing etc. of Compressed Air System to be used for Flue Gas Desulphurisation Plant Package of existing 2 x 500 MW Tuticorin Thermal Power Station at Tuticorin, Tamil Nadu of NLC Tamil Nadu Power Limited (NTPL).

2.00.00 CODES AND STANDARDS

2.01.00 In addition to the requirements spelt out elsewhere in the specification the equipment to be provided under this section shall specifically conform to the following codes, standards, specifications and regulations as applicable, including all its latest amendments subsequent to the year of publication as mentioned below:

2.01.01	IS-2825	:	Code for unfired pressure vessels.
2.01.02	IS-4503	:	Specification for Shell and Tube Type Heat Exchangers.
2.01.03	CAGI	:	Compressed air and gas institute.
2.01.04	IS-5727	:	Glossary of Terms Relating To Compressors And Exhausters.
2.01.05	IS-1239: Part-I	:	Steel Tubes, Tubulars and Other Wrought Steel Fittings - Specification - Part 1: Steel Tubes.
2.01.06	IS-1239: Part-II	:	Mild steel tubes, tubulars and other wrought steel fittings, Part 2 Mild steel tubulars and other wrought steel pipe fittings.
2.01.07	IS-6206	:	Guide for Selection, Installation and Maintenance of Air Compressor Plants with Operating Pressures up to 10 bars.
2.01.08	ANSI-B16.5	:	Steel Pipes Flanges and Fittings.
2.01.09	IS-7938	:	Specification for Air Receivers for Compressed Air Installation.
2.01.10	BS-5169	:	Specification for fusion welded steel air receivers.





2.01.11	IS-10431	:	Measurement of air flow of compressors and exhausters by nozzles.
2.01.12	IS-4736	:	Specification for Hot-dip Zinc Coatings on Mild Steel Tubes.
2.01.13	IS-11780	:	Code for selection and testing of rotary screw air compressors (oil flooded).
2.01.14	IS-11989	:	Specification for Compressed Air Dryers.
2.01.15	IS-14875	:	Compressed Air Filters – Evaluation Parameters.
2.01.16	IS-11727	:	Measurement and evaluation of vibration severity in situ of large rotating machines with speed range from 10 to 200 rev/s.
2.01.17	IS-5456	:	Code of Practice for Testing of Positive Displacement Type Air Compressors and Exhausters.
2.01.18	ISO 8753.1	:	Compressed air – Contaminants and Purity class.
2.01.19	IS 3401	:	Silica Gel.
2.01.20	ISO 10816	:	Mechanical vibration - Evaluation of machine vibration by measurements on non-rotating parts
2.01.21	ISO 7919	:	Mechanical vibration of non-reciprocating machines - Measurement on rotating shafts and evaluation criteria
2.01.22	IS 3589	:	Steel pipes for water and sewage (168.3 to 2540 mm outside Diameter) - Specification
2.02.00	In case of any contradiction with the aforesaid standards and the stipulations as per this Section and Attachments/Annexures of this section, the stipulations of this Section and its Annexures shall prevail. In case of any contradiction between this Section and Attachments/Annexures, stipulations of Attachments/Annexures shall prevail. The latest amendment to the standards are applicable at the time of finalization of engineering		
3.00.00	SYSTEM DESCRIPTION		
3.01.00	The Compressed Air System for FGD Plant of the existing 2x500 MW units shall meet the requirement of Instrument Air for the control of various pneumatically operated instruments/ valves of FGD Plant and the Service Air		





for general plant services for the FGD Plant area. The air compressors shall be installed in the compressor house, which shall be located adjacent to FGD Plant Area

- 3.02.00 Air drying plants with Heat of Compression (H.O.C) type regeneration system shall be provided to ensure dry, moisture free instrument quality air. The Air Drying Plants will be located inside the same building with air compressor. The schematic arrangement of Compressed Air System (within Compressor House) has been shown in Drawing No.: 17A14-DWG-M-001D.
- 3.03.00 Compressors, after coolers and intercoolers shall be of water cooled type and shall utilise Passivated DM water for cooling purposes from the DMCW system of the FGD Plant.
- 3.04.00 Air receiver shall be provided for each air compressor to meet sudden surge and peak requirements

4.00.00 **SPECIFIC DESIGN CRITERIA AND PERFORMANCE REQUIREMENTS**

- 4.01.00 The Compressed Air System for FGD Plant shall ensure a reliable supply of adequate quantity and quality of oil free air on continuous and intermittent basis for the existing (2x500) MW Units.
- 4.02.00 The normal pressure of instrument quality compressed air supply at the outlet of Air Dryer shall be 7.5 Kg/sq.cm (g) and shall not be lower than 7.0 Kg/sq.cm (g) under any circumstances. Corresponding to the normal pressure at the outlet of dryer, the rated discharge pressure of compressor shall be worked out by the Bidder, allowing for pressure drops in system piping, equipment and all other accessories. The rated discharge pressure of compressor shall be computed as per guidelines specified above or 8.5 kg/sq.cm (g), whichever is higher.

The maximum expected pressure in the system shall be computed by considering 10% overpressure over and above the rated discharge pressure of each air compressor as computed above.

- 4.03.00 The total Compressed Air requirements for FGD Plant of existing 2x500 MW Unit shall be assessed by the following guideline.

$$Z = [A+B] \times [1+ (mw+ml)/100], \text{ where,}$$

A = Total Instrument Air requirement for FGD Plant for both units.

B = Total Service Air requirement for FGD Plant for both units.

mw = Wear & tear margin = 10%

ml = Leakage margin = 10%

Z = Total compressed Air requirement for FGD Plant of the existing 2x500MW unit.





However, bidder shall arrive the sizing of compressor based on the following criteria also:

1. Both units under normal operation
2. One unit under start up and one unit under normal operation

Higher of these values shall be used for calculating the compressor capacity

- 4.04.00 Compressed air system shall comprise of one (1) group of Air compressors and one (1) group of air drying units to meet FGD Plant requirement of existing 2x500 MW units. The capacity of each air compressor shall be as per clause No. 4.03.00.
- 4.05.00 The compressed air system shall consist of 2x100% capacity compressors (i.e. one (1) working and one (1) standby for FGD Plant of existing 2x500 MW units) with necessary intercoolers, after coolers, piping, valves, instruments and other accessories with built-in control panel and supplemented by an Air Drying plant for each air compressor. There shall be one (1) Air Receiver for each air compressor.
- 4.06.00 Equipment operating on compressed air system shall be designed for a pressure range of 5.5 Kg/cm² (g) to 110% of rated discharge pressure of each air compressor, as computed in accordance with clause no. 4.02.00 above.
- 4.07.00 The delivered compressed air shall not contain any trace of oil, grease or any other impurities. Size of particles in the delivered air shall not exceed 3 Microns.
- 4.08.00 Compressed air system equipment requiring DM cooling water shall be capable of operation at design capacity with DM cooling water inlet temperature subject to a maximum of 39°C in DM cooling water (DMCW) system. The above equipment shall also be capable to withstand a pressure not less than the shut off head of each DMCW pump. Accordingly, facilities for DMCW shall be arranged from both the units.
- 4.09.00 The temperature of air at outlet from after cooler shall not exceed 10°C above the cooling water inlet temperature.
- 4.10.00 Air Compressors shall be identical and shall be designed for continuous operation with high efficiency to satisfy the performance requirements as specified in Annexure-I enclosed with this section.
- 4.11.00 The power rating of the driver shall be selected such that a minimum margin of 15% is available over the power required to deliver rated capacity against rated discharge pressure. When the driver is not directly coupled to the compressor, due account should be made for losses in power transmission, in addition to the above margin.
- 4.12.00 As more than one (1) compressor with drive is specified, satisfactory operation in parallel shall be ensured without any uneven load sharing, undue vibration, keeping noise level within permissible limits for a number of





compressors working simultaneously.

- 4.13.00 Each Air Receiver shall be so sized that even in the event of total stoppage of air inflow to the same, the pressure in the Air Receiver shall not fall below 5.5 kg/cm² (g) within two (2) minutes of such stoppage, while maintaining an out flow of air at a rate equal to the rated capacity of a single compressor, during the aforesaid period. In no case, the size of each Air Receiver shall be less than that arrived from IS 7938.

The capacity of each Air Receiver shall be determined in accordance with the following guidelines:

$$V_{AR} = \frac{T \times C \times P_A}{P_{MAX} - P_{MIN}} \times E$$

Where,

V_{AR} = Volume of each Air Receiver in M³.

T = Bleed down time in minutes, shall be taken as 2 minutes (minimum).

P_A = Atmospheric pressure, shall be taken as 1 Kg/Sq.cm (absolute).

P_{MAX} = Maximum system pressure in Kg/Sq.cm absolute, shall be taken as 110 percent of rated compressor delivery pressure.

P_{MIN} = Minimum system pressure in Kg/Sq.cm absolute, shall be taken as 6.5 Kg/Sq.cm absolute.

C = Free air delivery capacity of each Air compressor, M³.

E = 1.15, considering 15 percent minimum margin to account for peak requirements.

The water filled volume of each Air Receiver shall be calculated in accordance with the guidelines specified above or 6.5 M³, whichever is higher.

- 4.14.00 The drying capacity of each Air Drying Plant (ADP) shall be provided to match the corresponding capacity of each Air compressor.
- 4.15.00 The air drying plants receiving compressed air saturated with moisture shall be capable of operating continuously to provide reliable moisture free compressed air. Dew point of the outlet air measured at the stated operating pressure shall be as mentioned in Annexure-II or lower throughout the operation. For calculating moisture load, relative humidity and dry bulb temperature at ADP inlet shall be taken as 100% and 40°C respectively.
- 4.16.00 The drying process shall employ the Heat of compression drying by adsorption method to remove moisture from air.
- 4.17.00 Driers shall be suitable for part load operation while maintaining the outlet air





dew point as specified above. Necessary instruments and controls shall be provided to ensure that the specified dew point is maintained irrespective of input variations.

4.18.00 The Bidder shall assume full responsibility in the operation of the air drying plant as a whole.

4.19.00 For the air drying capacity and all other relevant details pertaining to Air Drying Plant, Annexure-II shall be referred to.

5.00.00 **SCOPE OF SUPPLY AND WORKS**

5.01.00 **Scope of Supply**

The detailed scope of supply under this section shall be as below and as indicated in relevant tender drawings. Items not specifically mentioned but deemed necessary to make the system completely reliable and efficient shall also be included.

5.01.01 2×100% oil free rotary screw type air compressors shall be provided for FGD Plant of existing 2×500 MW unit. There shall be one (1) Air Receiver for each air compressor located outside the compressor house itself.

Each Air Compressor shall be complete with Intake Air filter cum Silencer, Intercooler, after cooler, Moisture Separator, interconnecting piping, valves, drive motors, instruments and all other accessories.

5.01.02 One (1) no. PLC-based control panel in built with each air compressors and one (1) local control panel for each Air Drying Plant shall be provided.

Each built-in control panel for the compressors shall be complete with necessary PLC Hardware and Software, push buttons, annunciators as needed to make the system completely reliable and efficient. Necessary anti-vibration pads for free standing in case of vertical control panels are to be provided.

5.01.03 All Cooling water piping, control air and interconnecting air piping, valves, supports and hangers, instruments as indicated in tender drawings and as required for smooth, reliable and efficient functioning of the system.

5.01.04 One (1) no. air drying plant (HOC type) for each air compressor shall be provided by the Bidder. Each air drying plant shall be complete with the following accessories:

- i) Air Ejector as applicable.
- ii) Filters and coolers, as required.
- iii) Moisture separator with auto drain trap.
- iv) Rotor drum/Tower loaded with desiccant and drive motor, as required.
- v) Dryer container/tower.
- vi) Regeneration line control valve





Tender Specification
for
FGD Package

NLC Tamil Nadu Power Ltd.
2x500 MW Project
Tuticorin, Tamil Nadu

- vi) Regeneration air cooler.
 - vii) All inter-connecting/integral piping, valves, trap stations with by-pass valves at drains, fittings, flanges, gaskets, etc.
 - viii) Instrument and controls.
 - ix) Interconnecting wiring.
 - x) Differential pressure indicator.
 - xi) One (1) dew point indicator.
- 5.01.05 Supporting structures, base plates, support plates, foundation/ anchor bolts, nuts, sleeves, inserts, lifting lugs, eye bolts, etc. as needed for efficient installation and handling of equipment.
- 5.02.00 For general guidelines/details regarding scope of services and works, Volume II-A of this specification shall be referred to.
- 6.00.00 **DESIGN AND CONSTRUCTION**
- 6.01.00 The Compressors shall be designed to deliver the nominal capacity at the required delivery pressure as mentioned in Annexure-I of this section.
- 6.02.00 The design shall be such as to ensure trouble free operation with least vibration and noise. Suitable acoustical treatment will be provided to ensure the noise level within permissible limits as specified in Volume II-A. Different parts of the compressor and accessories shall be arranged neatly in a compact manner. Due consideration shall be given for easy accessibility and maintenance of the compressors.
- 6.03.00 The compressors shall be non-lubricated, oil free, horizontal, multi-stage water cooled, electric motor driven screw type, heavy duty, rugged construction. Their speed shall be so selected as to result in low maintenance and trouble-free operation under specified conditions.
- 6.04.00 Unless inconsistent with this section, equipment from the standard range of manufacture of the Bidder shall be preferred.
- 6.05.00 Compressor components shall be interchangeable as far as possible. Material of construction shall be suitable for the service.
- 6.06.00 Design capacity, outlet pressure and the material of construction for various parts of the compressor and accessories shall be as specified in Annexure-I enclosed with this section.
- 6.07.00 **Compressor casing, rotor and shaft**
- 6.07.01 Compression chamber wall thickness shall be such that to withstand maximum design pressure.
- 6.07.02 During maintenance of compressor suitable arrangement for cleaning of the cooling water jackets shall be provided.





- 6.07.03 Dynamically balanced, one-piece Rotor construction with a symmetric profile to keep leakage loss to a minimum and ensure high efficiency.
- 6.07.04 Rotor shaft mounted, highly precise timing gears shall be designed to counter the axial forces incurred in compression.
- 6.07.05 The rotor and shaft shall be of single piece construction, made of forged steel with suitable corrosion resistant coated material to minimize leakage and wear (AISI C1141 or equivalent). The stator (casing) shall be of Cast-Iron Construction with corrosion resistant material and with integral jacket cooling.
- 6.07.06 The shaft sealing and retainers shall be free for radial self-adjustment on the rotor shafts.
- 6.07.07 The seal rings and retainers shall be of stainless steel construction. The seals shall prevent air and oil leakage along the shaft. Air vented from second stage discharge end seals shall provide buffer air to the other seals to prevent migration of oil towards the compression chamber under all operating conditions.
- 6.07.08 The gaskets shall be of asbestos free material.
- 6.07.09 Use of Oil lubricated anti friction type bearings to be at least 8000 running hours.
- 6.08.00 **Lubrication system**
- 6.08.01 The compressor package shall include a lubricant management system which shall lubricate the bearings and seal. By the design, the compressor chamber (screw rotor housing) is totally separated from bearing / gear chamber.
- 6.08.02 The lubricant pump shall be shaft driven. An auxiliary motor driven pump shall be provided if required by the manufacturer to supply pre-start and shut down system. All lube oil pumps shall be of rotary positive displacement type, having stainless steel rotors and steel casing. The pump discharge system will be protected by a relief valve.
- 6.08.03 The heat exchanger for lube oil cooler shall be water cooled. The heat exchanger shall be located within the enclosed compressor skid.
- 6.08.04 The fouling factor shall be considered as per the recommendation of TEMA.
- 6.08.05 The lube oil cooler shall be designed for a heat duty corresponding to the peak power demand of the compressors.
- 6.08.06 The cooler shall be designed in accordance with the requirement of IS-2825.
- 6.08.07 Due consideration for the differential expansion of shell and tube shall be given in the design of the coolers.
- 6.09.00 **Gear Box**





Tender Specification
for
FGD Package

NLC Tamil Nadu Power Ltd.
2x500 MW Project
Tuticorin, Tamil Nadu

- 6.09.01 Speed increasing gears between the motor and compressor stages shall consist of a common helical gear driving the pinion of each stage. Helical timing gears shall be mounted on the rotor shafts to maintain accurate relative rotor position. Gears shall have a rating of AGMA-12 or equivalent.
- 6.10.00 Inter Cooler, After Cooler and Moisture Separator
- 6.10.01 Inter-cooler shall be located between the low and high-pressure stages, if required, to reduce overall power consumption. Design performance shall be in accordance with Manufacturer's Standard and wall thickness of tubes and expansion joints shall ensure maximum trouble-free service for long period.
- 6.10.02 Design of intercooler and after cooler shall be such as to keep the Cooling Water pressure drop within limits and complete leak tight condition for long period of service time.
- 6.10.03 After-cooler at each compressor discharge shall be water cooled and supplied by the Bidder. It shall be located after compressor discharge to bring the outlet temperature of the compressed air within 10°C, of the cooling water inlet temperature. The moisture separator to be provided on after cooler air outlet shall have suitable internal baffling for removal of moisture and oil. Necessary safety valves shall be provided on inter coolers and after coolers.
- 6.10.04 Inter-cooler, After-cooler and Moisture Separator shall be provided with Auto trap stations including strainer, bypass and double isolating valves for the traps. A level gauge glass with isolating cock shall be provided near the bottom of moisture separator. Automatic traps shall be of reputed make and shall be of float type suitable for intended services. Y-strainer of 20-mesh screen of stainless steel shall be placed before each trap.
- 6.10.05 The after coolers and water cooled intercoolers shall be shell and tube type. The intercooler shall have air in shell side and water in tube side to add surge volume for reducing air pulsation before the second stage.
- 6.10.06 The shell, tubes, tube sheets and expansion joints with tube sheets particularly at flange portion etc. of the heat exchangers shall be designed to withstand the maximum working pressures encountered. Necessary allowance for corrosion shall be provided.
- 6.10.07 The tube nest shall be removable type to facilitate cleaning and maintenance.
- 6.10.08 Intercoolers/After coolers shall be provided with supports, which are designed to avoid undue stress or deflection in support or body of the equipment.
- 6.10.09 Due consideration for the differential expansion of shell and tube shall be given in the design of coolers.
- 6.10.10 Necessary drain and vent nozzles shall be provided for intercooler and after cooler.
- 6.11.00 **Air Receiver**





- 6.11.01 Air receiver(s) shall be in accordance with IS-2825 or ASME Sections-VIII Div.I and IS-7938.
- 6.11.02 The design pressure, capacity and other parameters shall be as specified in Annexure-I of this section.
- 6.11.03 The air receiver shall be vertical self-supporting cylindrical vessel with torispherical dished ends and with supporting stand for resting on the Civil foundation in accordance with Annexure-I enclosed with this section.
- 6.11.04 Receivers shall be of welded construction with minimum number of joints. Longitudinal seams in adjacent sections of shell shall not be in the same line.
- 6.11.05 All welding shall be performed in accordance with relevant codes. Filler material that will deposit weld metal with a composition and structure as near as that of the material being welded shall be used. The electrodes shall be dried in oven immediately before use to ensure freedom from porosity.
- 6.11.06 Receivers shall be provided with required number of nozzles, the orientations of which shall be subject to approval by the Purchaser. At least two gasketed inspection holes shall be provided for receivers up to 600 mm diameter. For larger diameter manhole of minimum 450 mm diameter shall be provided. All openings shall be placed as far as possible from welded seams and in no instance shall pierce the seam.
- 6.11.07 Receivers shall be provided with one or more safety relief valves of proper capacity so that the maximum working pressure of the system is not exceeded under any circumstance. Unless otherwise mentioned, each receiver shall be provided with at least one pressure gauge and one temperature gauge of proper range and required number of pressure switches for compressor control purposes.
- 6.11.08 Each air receiver drain connection shall be provided with automatic drain valve for automatic removal of drain consisting of valve, strainer, double isolation and bypass valves.
- Each Air Receiver should have air release vents at the top to facilitate statutory hydraulic tests.
- 6.11.09 Receiver shall be heat-treated in accordance with BS-5169 or equivalent Indian / international standard .
- 6.12.00 **Intake Air Filter and Silencer**
- 6.12.01 Filters with multiple elements and quick removal type for easy cleaning to be provided at suction of each air compressor and shall also be of heavy-duty dry type. Oil bath type shall not be acceptable for non-lubricated compressors.
- 6.12.02 The filters shall be complete with integral silencers and all other accessories. The filtering elements shall be easily removable for cleaning or for replacement.





- 6.12.03 The filters shall be designed for an efficiency of not less than 99.9% for particles 3 microns and larger.
- 6.12.04 The silencer shall be of very high efficiency type to adequately dampen the operating noise as per the requirements in Volume -IIA, Section-V.
- 6.12.05 Pulsation dampener of approved design shall be provided on the compressor suction and discharge manifold.
- 6.12.06 If filter after receiver is specified in Attachments/Annexures, the same shall be provided to remove the bulk of moisture and other contaminants entrained in the air stream.
- 6.13.00 **Drive Unit**
- 6.13.01 The compressors shall be driven by constant speed squirrel cage induction motor unless otherwise specified in Annexure - I of this section. For determining the output rating of driver, general guidelines as indicated in Cl. no. 4.11.00 of this section and Volume : II-F/1 & II-F/2 of this specification shall be followed.
- 6.13.02 The driver shall be connected to the compressor either directly or through gear box as per Annexure-I of this section.
- 6.13.03 For other types of connection between drive unit and compressor, suitable flexible coupling shall be provided.
- 6.13.04 Necessary guard shall cover all exposed moving parts.
- 6.13.05 Motor speed torque curve shall match with that of the compressor for trouble free start up.
- 6.13.06 Motor shall be suitable for three (3) equally spread starts per hour.
- 6.14.00 **Moisture Separator**
- Moisture separator shall be of high efficiency design and provided with vent nozzle and auto drain trap system.
- 6.15.00 **Air Drying Plant**
- Air-drying plant shall be of heat of compression desiccant type, drying by adsorption method.
- Reactivation shall be by Heat of compression method without any air purge loss. Hot unsaturated compressed air from compressor discharge (before after cooler) shall be used for regeneration of exhausted desiccant in ADP.
- Air dryer shall be Indoor located.
- All pressure vessels shall be designed as per IS: 2825 or equivalent code.





All vessels shall be included with required manholes/hand holes.

All hot vessels & pipelines to be insulated to restrict the outside temperature within 60 deg. C with mineral wool (or equivalent).

Quantity of desiccant to be calculated taking into account residual moisture content at the end of regeneration cycle. Design calculation with curves shall be submitted for approval of Owner/Consultant.

Desiccant filling and removal connections shall be provided.

Complete ADP equipments shall be preferably mounted on a skid.

Required connections in piping shall be provided for sampling of air at desired locations.

6.16.00 **Pressure Vessels**

6.16.01 All pressure vessels shall be designed as per IS : 2825 or equivalent code.

6.16.02 The vessels shall be of self-supporting construction. All welding materials and procedures shall be as per IS: 2825 or approved equal.

6.16.03 Each vessel shall be provided with suitable air-tight manhole and/or hand hole and other connections as required.

6.16.04 Relief valves of adequate capacity shall be provided for each vessel. Relief valves shall be provided with hand lever. The valves shall be of stainless steel construction.

6.16.05 Internal surfaces of all the vessels shall be suitably protected against corrosion and rusting. Corrosion allowance of 2.5 mm shall also be provided on shell and dished end thickness.

6.16.06 Draining trap station complete with Auto drain trap, isolation and by-pass valves and Y-strainer shall be provided for the moisture separator.

6.17.00 **Solenoid Valves and Multiway Valves**

6.17.01 The solenoid valve shall be of approved make. The solenoid valves shall have heavy duty, double impregnated tropicalised coils (Single or double solenoid as required) and shall be suitable for the operating temperature and for operation continuously energised, in a tropical climate.

6.17.02 The solenoid valves shall be of bronze body with stainless steel trim preferably. The coil shall be of continuous duty and of epoxy moulded type (Class-F). The enclosure shall be watertight, dust tight, weather proof and shall conform to NEMA-4X standard. The valves shall be suitable for mounting in any position. Solenoid coils shall be Class-H high temperature construction and shall be suitable for continuous operation. Type of operation and electrical ratings shall be subject to the Purchaser's approval.





6.18.00 **Drives and Mounting**

6.18.01 All relevant details pertaining to drives shall generally comply with the stipulations laid in Volume : II-F/1 & II-F/2.

6.18.02 All the components of the Air Drying plant including the strainers, filter, interconnecting piping, valves, fittings, control panels, etc. shall be mounted on a common fabricated steel base frame to form a self contained unit.

6.19.00 **Interconnecting Piping, Valves and Fittings**

6.19.01 Pipelines shall be selected as per relevant standard. Piping in airlines and cooling water lines up to 50 NB shall be socket welded and 65 NB and above shall be butt-welded / flanged type. All interconnected air piping and cooling water piping etc., as indicated in tender drawings shall be furnished by the Bidder, complete with valves, fittings, pipe supports as necessary. The piping shall be as per the Codes/Standards specified in Annexure-I enclosed with this section.

6.19.02 The air discharge piping shall be full size of compressor outlet or larger, short and direct with minimum number of fittings. Only long radius elbows shall be used where bends are unavoidable. The velocity of compressed air in pipe shall be limited between 20 Meters/Sec. to 30 Meters/Sec.

Any pocket in compressed air and interconnecting air piping shall be provided with drain connection complete with automatic trap station.

Long runs of more than 10 m of vertical piping at compressor discharge shall not be acceptable.

The layout shall be such as to prevent resonance. Provision of thermal expansion of hot pipes shall be made.

All pipe connections with equipment shall be flanged type. All pressure gauges/switches shall be complete with root valves and all temperature elements shall be mounted in a proper thermowell.

All instruments, safety valves etc. as shown in tender drawings shall be furnished on the piping.

6.19.03 For water cooled compressors, cooling water shall normally be piped through the intercooler and after cooler in parallel. From the intercooler, the water shall be taken to cylinder jackets. A solenoid valve shall be provided on the water inlet line for interlocked starting of compressors. Where provision for automatic water flow regulation by thermostatic valve has been made, a suitable bypass arrangement to the valve shall be made so that flow to the cylinder is ensured under all circumstances.

The velocity in water pipes shall be limited to 2.0 Metres/Sec.

Sight flow indicators shall be provided on water discharge from each cylinder,





intercooler and after cooler.

- 6.19.04 Valves to be supplied for compressed air service and DM cooling water service shall be as per Annexure-II & III of Section-II in Volume : II-D.
- 6.19.05 All traps shall be float operated. All traps shall be of auto drain type to drain out moisture at regular intervals. The body and cover shall be of cast iron/solid steel construction and internals shall be of SS. Isolating valves shall be of stainless steel.
- 6.19.06 All strainers shall be Y-type with suitable blow-off plugs. The body material shall be cast iron. The screen shall be of stainless steel with 40 mesh openings.
- 6.19.07 Complete piping system shall be provided with adequate supporting arrangement to avoid undue forces and moments at the equipment terminals and vibration.
- 6.19.08 All other pipes and equipment conveying hot air shall be properly insulated to limit outside surface temperature to 60°C as per application details vide Volume-II-D. The insulating material shall be glass or mineral wool as per IS-3690/IS-3677/with chicken wire net and 22 gauge aluminium cladding.

6.20.00 Dew Point Indicator

Dew point indicator shall be digital type for spot measurement of dew point of air. The specification of the meter shall be as follows:

- a) Range : (-) 40 °C to (+) 20 °C
- b) Accuracy : ± 0.2 °C

Dew point monitoring facility shall also be provided in local Control Panel as well as in unit DCS operator work station.

7.00.00 INSTRUMENTATION AND CONTROL

7.01.00 Instrumentation

- 7.01.01 a) Individual gauge board with anti-vibration mounting shall be provided near each compressor where pressure, temperature gauges are to be mounted. In case of gauges and indicating switches, sufficient length of impulse pipe or capillary shall be supplied so that all the instruments can be mounted on this local gauge board with minimum vibration of the floor and to facilitate operating personnel for viewing. A local Gauge board shall be provided for each compressor for indication of all-important parameters such as pressure, temperature, flow related to the compressor.
- b) The instruments for each Air Drying plant shall be local type. In case of all gauges and switches as represented in the schematic flow diagram, sufficient length of impulse pipe or capillary shall be supplied





so that all the instruments can be mounted on a local gauge board to be provided near each ADP to facilitate operating personnel for viewing. In-line flow gauge & flow switch shall be provided on the cooling water line of the compressed air system.

- c) For temperature indicators, thermowell dimension should be such that the bottom must reach the centre line of the pipe. For lower size lines thermowells should be mounted at bends or to be mounted suitably with the help of expanders. Thermowell dimensions shall be selected as per the guidelines specified in Volume IIE of this specification. For indication of temperature at a remote location such as gauge board or compressor air control panel, temperature detector and digital indicator will be provided.
- d) All other instruments like pressure gauges, temperature indicators, pressure and temperature switches etc. shall be of reputed make and as per relevant specifications/codes. The minimum dial size for dial type instruments shall be 150 mm. The repeat accuracy of indication and contact operation shall be within $\pm 1\%$ of full range. Temperature detector will be provided at each stage of the compressed air system and cooling water system of compressor for monitoring on the local control panel and also in the FGD Plant control room.
- e) Instruments should be provided based on the P&I drawing and requirements mentioned in Volume : IIE of this specification.
- f) For detail hardware specification for instruments and the PLC refer to Volume-IIE of this specification.
- g) Dew point Measurement

Dew point measurement shall be provided for each Heat of Compression (HOC) type Air drying plant of compressed air system. The output of the instrument shall be 4-20 mA DC to be connected to unit DCS.

7.02.00 **Control Concept of Compressors**

7.02.01 Each compressor shall be controlled by dual control method to maintain receiver pressure within narrow limits. Dual control method permits the operation of a compressor in either of the two following ways:

- a) Continuous run load - unload control.
- b) Automatic start/stop control.

One selector switch for each compressor shall be provided in the control panel to achieve any of the above controls. Each selector switch shall have three positions: "base duty" (Load-Unload control), "Standby duty" (Auto-start/stop control) and "Stop". Each compressor shall operate in 50% or 100% load under load/unload mode of control depending on system demand. The compressors shall be primarily





controlled from local control panels and status indication of the same shall be provided on local control panel as well as on the operators' station in FGD Plant control room. Other details of control concepts are elaborated in Volume II-E.

7.03.00 Control System Description

- a) Product specific microprocessor/ microcontroller based control system shall be provided for each compressor for interlock and protection for the compressor and auxiliaries. The operational facility of each compressor shall be provided from independent local control panel dedicated for each compressor.
- b) Instrument air dryer control shall also be based on product specific microprocessor/ microcontroller and will be interfaced with overall compressor control system.
- c) All field instruments/ devices shall be connected to station DDCMIS.
- d) Annunciation windows and hooter will be driven from microprocessor/ microcontroller output card and required annunciation sequence will be programmed in application software of microprocessor/ microcontroller based control system.
- e) All indications on the panel, and illumination of annunciation windows shall be provided with clustered LED of required colours as applicable.
- g) All commands from station DDCMIS to field devices, MCC/SWGR shall be through interposing relays and shall be routed through microcontrollers of individual compressors.

7.04.00 Interfacing With Plant DCS

- a) The compressor control system will be interfaced with DDCMIS through software link. Complete information and alarms related to abnormal conditions of compressors shall be available to FGD Plant control room for monitoring purpose.
- b) Provision shall also be made to hook-up the compressor control system with DDCMIS through hardware interface for remote start/ stop and feedback to/ from DDCMIS and monitoring of critical parameters of compressors and air drying plants.

7.05.00 Annunciation System

7.05.01 Annunciation shall be provided for following conditions for the compressed air system:

- i) Compressor motor tripped
- ii) Lub. oil pressure - low.





Tender Specification
for
FGD Package

NLC Tamil Nadu Power Ltd.
2x500 MW Project
Tuticorin, Tamil Nadu

- iii) Air temperature at inlet of after cooler-high.
- iv) Air temperature at outlet of after cooler-high.
- v) Air temperature at outlet of inter cooler-high.
- vi) Air Pressure in receiver-high and low.
- vii) Cooling water flow to compressor - low
- viii) Cooling water pressure - low.
- ix) Bearing and winding temperature of compressor motor - high and very high.
- x) Air pressure after cooler - high.
- xi) Compressor discharge pressure - high and low.
- xii) Air pressure low (common for a group of compressors).
- xiii) Cylinder jacket cooling water outlet temperature - high.
- xiv) Lub. Oil temperature - high
- xv) Dryer trouble
- xvi) Any other annunciation as may be necessary for safe and trouble free operation of the system.

7.05.02 Suitable provision for duplication of all the annunciations at remote control board shall also be provided.

7.06.00 **Interlock**

7.06.01 The following safety interlocks shall be provided for the compressed air system:

- a) Compressor trip on low lube oil pressure.
- b) Compressor trip on high air temperature at compressor discharge.
- c) Compressor trip on high cylinder jacket water temperature (for water cooled compressors).
- d) Compressor start only after coolant flow is established.
- e) Compressor trip due to low cooling water flow.
- f) Any other interlock as required for safe and reliable operation of the system.





- 7.06.02 All pressure and temperature conditions used for tripping the compressor shall be provided with pre-trip annunciation in the local control panel.
- 8.00.00 **INSPECTION AND TESTING**
- 8.01.00 The Bidder shall carry out the following specific tests and inspections to ensure that the equipment furnished shall conform to the requirements of this section and in accordance with relevant codes and standards.
- 8.02.00 Material identification of compression chambers, rotor, rotor staff, suction and delivery valves constituting the compressors and all parts of intercoolers, after coolers, moisture separators, air receivers, strainers, filters, all interconnecting air and water piping with valves and all other parts and accessories that could not spelt out in this clause.
- 8.03.00 Hydrostatic testing of compressor, intercoolers, aftercoolers, moisture separators, air receivers, strainers, filters, all interconnecting air and water piping with valves and all other applicable pressure parts that could not be spelt out in this clause. Hydrostatic testing shall be carried out at 150% of the design pressure for at least one (1) hour, unless contradicted by the relevant test code.
- 8.04.00 **Specific tests to be carried out for each compressor**
- 8.04.01 Non-destructive testing of rotors, rotor shaft and all other applicable parts.
- 8.04.02 Type test/Routine tests for all the air compressors as per IS-5456. All performance tests for compressors shall be carried out with actual motor being furnished. Routine tests shall include the following tests and measurements:
- a) Capacity (Free Air delivery).
 - b) Speed.
 - c) Specific power consumption.
 - d) Volumetric and overall efficiency of machine.
 - e) Test of loading and unloading mechanism.
 - f) Any other test deemed necessary for the system.
- Note:
- i) Auxiliary Power Consumption shall be measured at the input terminals of actual job motor of compressor and Air drying plant, as applicable, by operating them at rated capacity and head at the test rig of manufacturer's shop floor.
 - ii) For compressor plant and Air drying plant, a duty factor of 0.6 shall be considered.
- 8.04.03 Dynamic balancing of all rotating components and assembly of each air compressor including all drive motors in the compressed air system.





- 8.04.04 Tests for capacity, pressure drop and efficiency of each Intake Air Filter with silencer shall be as Manufacturer's standard. These tests shall be conducted along with performance testing of each compressor.
- 8.05.00 Testing of all drive motors and control panels in the compressed air system shall be as outlined under Volume II-F/1 & II-F/2 of this specification.
- 8.06.00 Dew Point tests to be carried out on each Air Drying Plant.
- 8.07.00 Any other test deemed necessary as per relevant code for compressor testing for the system.
- 9.00.00 **DRAWINGS / DOCUMENTS, DATA AND INFORMATION TO BE FURNISHED BY THE BIDDER ALONG WITH THE TECHNICAL OFFER**
- 9.01.00 The Bidder shall furnish along with his proposal following specific drawings/documents/data as asked for in this section.
- 9.01.01 P&I Diagram. / Flow diagram
- 9.01.02 Preliminary Layout drawing.
- 10.00.00 **DRAWINGS / DOCUMENTS, DATA, AND MANUALS TO BE FURNISHED AFTER AWARD OF CONTRACT**
- 10.01.00 Final version of all drawings/data/information asked for in clause 9.00.00 above.
- 10.01.01 Calculations establishing the rated pressure, FAD capacity of compressors and characteristic curves showing efficiency against capacity, capacity of Air Receivers and ADPs.
- 10.02.00 Certified, dimensioned general arrangement drawing; detailed cross-sectional drawing with parts list and details of material; piping layout drawings for Compressed Air System.
- 10.03.00 Foundation drawings with dead load, operating load and other design data.
- 10.04.00 Functional logic diagram showing operational philosophy, inter lock and protection for the compressed air system.
- 10.05.00 Complete design calculations for heat exchangers, moisture separator, air receiver, etc.
- 10.06.00 Local panel layout and complete electrical schematic drawings for instrumentation and control.
- 10.07.00 Detailed list of Instruments showing make, size, range, tag nos. etc.





- 10.08.00 Bill of material indicating tag nos., type, sizes, working pressure, material of construction, quantity etc. of the following:
- a) Pipe
 - b) Valves and
 - c) Fittings
- 10.09.00 Detailed test reports, certified performance curves as required for all the applicable equipment in Compressed Air System.



**DATA SPECIFICATION SHEET
OF
SCREW TYPE AIR COMPRESSOR AND AUXILIARIES**

A. PERFORMANCE DATA

Free Air Delivery	:	Bidder to compute and indicate as per guidelines specified in this section.
Discharge Pressure	:	- Do -
Noise level near compressors	:	As per Vol.-IIA, Section-V.
Vibration limit (measured at top and bottom of main bearing)	:	40 microns.

B. CONSTRUCTION FEATURES

Location	:	Indoor
No. of compressors for FGD Plant	:	Two (2X100%) Nos. (1W+1S) of Air compressors.
Type	:	Oil-free, dry type, water-cooled, two (2) stage, rotary screw compressors.
Service	:	Compressed air supply for FGD Plant
Duty	:	Continuous.
Type of Drive	:	Electric Motor.
Design ambient for drive	:	50°C.
Number of starts per hour	:	3 (equally spread)
Type of transmission	:	Gear.
Anti - vibration arrangement required	:	Yes.
Maximum temperature for any step during the cycle	:	Bidder to indicate.
Type of control	:	Dual i.e., both load-unload and auto start/stop.
Type of Annunciation	:	Audio-visual.
Flange standard	:	ANSI B-16.5/equivalent.





ANNEXURE-I

C. MATERIALS OF CONSTRUCTION

Compressor chamber	:	Cast iron coated with corrosion resistant material.
Rotors	:	Forged carbon steel coated with corrosion resistant material.
Bearing	:	As per manufacturing standard.
Timing Gear	:	Low alloy steel.
Base Plate	:	MS.
Inlet throttle valve & housing	:	Aluminium.
Shaft seals	:	High Alloy Steel.
Safety valves	:	Brass.
Water separator	:	Cast Iron.
Blow off valve	:	Stainless Steel.
Unloading Cylinder header	:	Aluminium.
Tube of oil cooler	:	SS-304.
Outer casing of coolers	:	Carbon Steel.
Gear Box	:	Cast Iron.
Gears	:	Alloy Steel.

D. SUPPLY OF ACCESSORIES & SERVICES

Intake air filters with silencers	:	Yes
Intercoolers	:	Yes
Aftercoolers with moisture separators	:	Yes
All instruments as specified, as shown in tender drawing and as required for safe and trouble- free operation of the system	:	Yes
Coupling guards	:	Yes
Air receivers	:	Yes





ANNEXURE-I

Base plates : Yes
Earthing pads with foundation bolts, nuts, sleeves, inserts etc. : Yes

All interconnecting air and cooling water piping, complete with valves, fittings as shown in relevant tender drawings and as required for reliable and smooth operation of the system : Yes

Eye bolts, lifting tackle, tools, etc. : Yes

Control panels complete with all accessories : Yes

Instrument gauge panels complete with all accessories : Yes

E. DM COOLING WATER DATA

Quality : Passivated DM water.

Design inlet temperature : 36 °C (normal), 39°C (maximum).

Design pressure : Bidder to indicate. Shall not be less than the shut off head of DMCW pump.

Normal inlet pressure : Bidder to indicate. Shall be equal to the rated discharge head of DMCW pump.

pH value : 8.5 to 9.5.

Maximum pressure drop allowable between inlet and outlet points : 6.0 to 8.0 MWC.

F. TESTING AND INSPECTION

Material Testing and identification : Required.

Dye Penetration test : Yes

Type of performance test to be conducted : Routine test/Type test as per Clause No. 8.04.02 of this section.

Field performance test : Yes

MPI and UT tests : Yes

All other specific tests as specified in Clause No. 8.00.00 of this section : Yes





G. DRIVE MOTOR

Drive motor for compressor shall comply with the requirements of Clause No. 4.11.00 of this section and Volume IIF1 & IIF2 of this Specification.

H. COMPRESSOR ACCESSORIES

a) Intake Air Filter

Numbers required	:	One (1) no. with each compressor.
Location	:	Indoor/At the suction of each air compressor.
Type	:	Dry type.
Silencer	:	Yes
Air flow rate	:	To suit compressor rating.
Particle removing efficiency	:	99.9% up to particle size of 3 Micron.
Maximum allowable pressure drop at stated air flow rate in new condition of filter (viscosity of air at normal ambient temperature)	:	150 mm WG
Test requirement	:	No separate test. Compressor performance testing will include the filters in test set up. Capacity, pressure drop and efficiency shall be measured.

b) Air Receiver

Numbers required	:	One (1) for each Air compressor
Installation	:	Outdoor
Type	:	Vertical cylindrical with torispherical dished ends.
Design pressure	:	10 Kg/Sq.cm(g)
Hydraulic test Pressure	:	15 Kg/Sq cm(g)
Design code	:	IS-2825/IS-7938/ Approved equivalent code.





ANNEXURE-I

Capacity of each air receiver : Bidder to compute in accordance with Clause no. 4.13.00 of this section.

However, the water filled volume shall not be less than 2 M³ under any circumstances.

Material of construction of shell : IS-2002.

Material of construction of dished ends : IS-2002.

Material of construction of flanges : IS-2002.

Supply of Accessories & Services

Flanges with nuts, bolts and gaskets : Yes

Pressure gauge with snubber : Yes

Pressure switch : Yes

Temperature indicator : Yes

Relief valve : Yes, set pressure shall be at least 10% above working pressure.

Trap station : Yes

Level gauge : Yes

Vent valve/plug : Yes

Supporting stand with necessary foundation bolts, nuts, sleeves, etc : Yes

Eye bolts, lifting tackle, earthing lugs or pads etc. : Yes

Painting

i) External : Two coats of red-oxide primer and two finish coats of paints suitable for sea water environment.

ii) Internal : Shop painted as per manufacturer's standard suitable for sea water environment.





Inspection and Testing

Material testing and identification : Yes

Bend test as per BS-5169 : Yes

Spot radiography of circumferential and longitudinal butt welds : Yes

Field performance test : Yes

D.P. test where radiography cannot be done : Yes

Hydraulic Test : Yes

Other specific tests as specified in Clause No. 8.00.00 of this specification : Yes

c) Intercooler, Aftercooler, Moisture Separator, Piping, Valves etc.

i) **Aftercooler**

Installation : Indoor.

Type : Shell and Tube.

Relief Valve : Yes

Moisture Separator : Yes

Trap Station : Yes

Temperature Indicator : Yes

Temperature Switch : Yes

Level Gauge : Yes

ii) **Intercooler**

Installation : Indoor.

Type : Shell and Tube.

Relief Valve : Yes

Trap Station : Yes





Tender Specification
for
FGD Package

NLC Tamil Nadu Power Ltd.
2x500 MW Project
Tuticorin, Tamil Nadu

ANNEXURE-I

Pressure Gauge	:	Yes
Temperature Indicator	:	Yes
Temperature Switch	:	Yes
iii) Supply of Accessories and Services		
Supporting stands with bolts, nuts and gaskets	:	Yes
Eye bolts, lifting tackle etc with tools and tackle	:	Yes
Flanged connections for supply and return of cooling water	:	Yes
iv) Material of Construction		
Tube	:	Stainless steel.
Shell	:	Mild Steel.
Tube Sheet	:	IS 2002 Gr 2A.
Baffles	:	IS 2062
Flanges	:	IS 2062
v) Cooling Water Data		
	:	Same as mentioned earlier.
vi) Piping, Valves and Fittings for Compressed Air System		
Pipes for cooling water line	:	IS-1239 (Heavy grade) upto 150 NB. IS-3589 for sizes above 150 NB with minimum pipe thickness of 6 mm.
Pipes for compressed air line & interconnecting air line	:	Stainless steel as per ASTM-A312 GR.304. Size – as per schedule 40S. ANSI-B36.19 up to 50 mm NB and as per schedule 10S. ANSI – B36.19 for sizes equal to & greater than 65 mm NB.
Fittings		
Fittings for cooling water line	:	ASTM A-234 Gr. WPB for sizing including 65 mm NB and above. ASTM A105 for sizes up to 50 mm NB.
Fittings for compressed air piping	:	Stainless steel as per ASTM A-182 F304





& interconnecting air piping

Valves for air line : Stainless Steel.

Valves for cooling water line : As per Volume II-D

vii) **Testing and inspection** : As per clause No. 7.00.00 of this section.





**DATA SPECIFICATION SHEET
OF
AIR DRYING PLANT AND AUXILIARIES**

A. General Information

Numbers of Air drying Plant (for FGD Plant)	:	Two (2) nos. - one (1) for each Air compressor.
Duty	:	Continuous.
Service	:	Instrument Air
Installation	:	Indoor.
Type of Drying	:	Adsorption.
Type of Reactivation	:	Heat of compression .
Desiccant	:	Silica gel as per IS-3401 / Activated alumina.
Outlet dew point	:	At least (-) 40°C at 1 atm pressure.
Annunciation	:	Local and remote.

B. Performance Specification

Air drying capacity	:	To suit the compressor capacity.
Inlet air pressure	:	To suit compressor rating.
Inlet air temperature	:	To be indicated by Bidder.
Maximum allowable air pressure drop	:	0.5 kg/sq.cm.

C. Material

Absorber vessels and its internal	:	SS-304.
Regeneration air cooler shell & tube sheet	:	SA-285 Gr. C or equivalent.
Relief valves	:	Brass or SS.
Tube of Heat exchanger	:	SS.
Desiccant	:	Silica Gel / Activated Alumina.





D. Supply Of Accessories And Services For Each ADP

Pre-filters and After Filters	:	2 × 100% with automatic drain trap filter arrangement, and ceramic candle type filters.
Dew point indicator	:	Yes
Instruments as per specification, Tender drawing and as required for safe and trouble free operation	:	Yes
Control panel with accessories	:	Yes
Tools and tackle	:	Yes
Spare parts	:	Yes
All interconnecting piping complete with fittings, valves etc	:	Yes
Insulation	:	Yes
Base frame, foundation bolts, nuts, sleeves etc.	:	Yes
Vessel internal point	:	Anti-corrosive.
Shop painting		
i) Internal	:	Anti-corrosive heat resistant paint suitable for sea water environment..
ii) External	:	2 coats of red-oxide primer (120 micron DFT) with finish paint suitable for sea water environment.

E. Inspection and Testing

Non destructive material test	:	Yes
Hydrostatic test	:	Yes
Performance tests at shop	:	Yes
Performance tests at site	:	Yes
Spot Radiography of welds parts to be tested	:	All pressure parts and vessels.
Dye Penetration test	:	Yes





VOLUME : II-D

SECTION - I

PIPING, VALVES AND SPECIALTIES





CONTENT

CLAUSE NO.	DESCRIPTION	PAGE NO.
1.00.00	INTRODUCTION	1
2.00.00	CODES AND STANDARDS	1
3.00.00	SCOPE OF SUPPLY AND SERVICES	3
4.00.00	DESIGN AND CONSTRUCTION	4
5.00.00	INSTALLATION	10
6.00.00	DRAWING, DATA AND INFORMATION REQUIRED	12

ATTACHMENTS

ANNEXURE-I	SPECIFICATION OF PIPES & FITTINGS	13
ANNEXURE-II	SERVICES OF VARIOUS CATEGORIES OF VALVES	16
ANNEXURE-III	SPECIFICATION OF GATE/GLOBE/CHECK/BALL VALVES	17
ANNEXURE-IV	SPECIFICATION OF BUTTERFLY VALVE	19





VOLUME : II-D

SECTION-I

PIPING, VALVES AND SPECIALTIES

1.00.00 INTRODUCTION

This section covers technical requirements of all piping, associated valves and specialties that include but is not limited to the following systems.

1.01.00 Slurry Piping – shall consist of all Slurry piping within the Flue Gas Desulphurisation system such as Limestone slurry, Gypsum slurry, etc

1.02.00 Process Piping – shall consist of various categories of piping as required for operation of the FGD Plant.

1.03.00 Service Air System - shall consist of distribution of Service air for general housekeeping terminated at hose valves at buildings/ facilities of the FGD Plant.

1.04.00 Instrument Air System - shall consist of distribution of instrument quality air to pneumatically operated instruments/ valves/dampers of the FGD Plant.

1.05.00 Service water system (clarified quality) from Terminal Points to Storage tank and subsequent distribution points for process use.

1.06.00 Drinking Water System - from Terminal Point to auxiliary buildings included under FGD package.

1.07.00 Fire water system - from Terminal Points to distribution points for emergency cooling.

1.08.00 Demineralised Closed Cycle Cooling Water System – from Terminal points to and from equipment coolers within FGD Plant.

1.09.00 Waste water – shall consist of waste water generated in the FGD Plant upto Terminal point.

1.10.00 Any other low pressure piping as found necessary during detail engineering stage shall also be included.

2.00.00 CODES AND STANDARDS

2.01.00 In addition to the requirements spelt out in Volume IIA (Lead Specification), Section-V, of this specification, the design, manufacture, inspection and testing of the piping, fittings, valves and specialties covered under this specification shall conform, in general, to the standards and codes (latest edition) mentioned below :

2.01.01 IS-1239 : Mild steel tubes, tubular and other wrought steel fittings.
[Part-I & II]





Tender Specification
for
FGD Package

NLC Tamil Nadu Power Ltd.
2x500 MW Project
Tuticorin, Tamil Nadu

2.01.02	IS-3589	:	Electrically welded steel pipes for water, gas and sewage (150 to 2000 mm nominal diameter).
2.01.03	IS-554	:	Dimensions for pipe threads where pressure tight joints are required on the threads.
2.01.04	IS-1363 [Part-I & II]	:	Hexagonal head bolts, screws and nuts (size range M5 M36)
2.01.05	IS-1364	:	Precision and Semi-precision hexagon bolts, screws, nuts and lock nuts (diameter range 6 to 39 mm).
2.01.06	IS-3138	:	Hexagon bolts & nuts (M42 to M150).
2.01.07	IS-5312	:	Swing check type reflux (non-return) valves.
2.01.08	IS-2379	:	Colour code for the identification of pipelines.
2.01.09	IS-2016	:	Plain washers.
2.01.10	IS-2712	:	Compressed asbestos fibre jointing.
2.01.11	ANSI B-16.5	:	Steel pipe flanges and flanged fittings.
2.01.12	ANSI B-16.9	:	Wrought steel Butt welding flanged.
2.01.13	ANSI B-16.11	:	Forged steel fittings, Socket-welding and Threaded.
2.01.14	ANSI B-16.34	:	Steel Valves - Flanged and Butt Welding Ends
2.01.15	ASME B-36-10	:	Welded & Seamless Wrought steel Pipe
2.01.16	ASME B 36-19	:	Stainless Steel Pipe
2.01.17	ANSI B-36.10	:	Steel pipes thickness.
2.01.18	ANSI B-31.1	:	Code for Pressure Piping - "Power Piping".
2.01.19	IBR	:	Indian Boiler Regulations, with latest amendment.
2.01.20	API-600	:	Steel gate valves.
2.01.21	BS-2633	:	Class I Arc welding of ferrite steel pipe work for carrying fluids.
2.01.22	BS-534	:	Specification for steel pipes and specials for water and sewage.
2.01.23	BS-5351	:	Specification for Ball valves.
2.01.24	AWWA-C-504	:	Specification for Butterfly valves.





- 2.01.25 AWWA-C-208 : Dimension for fabricated steel water pipe fittings.
- 2.02.00 Other international codes and standards may also be offered by bidder. However, same may be subject to acceptance by the Owner/Consultant.
- 3.00.00 **SCOPE OF SUPPLY AND SERVICES**
- 3.01.00 The equipment and materials to be supplied under this section shall include but not be limited to the following:
- a) Supply of all low pressure piping including bends, elbows, tees, branches, laterals, crosses, reducing union, couplings, caps, saddles, shoes, flanges, blank flanges, Y-pieces etc. as required for the piping system under the scope of this section.
 - b) Matching pipes, matching pieces like reducers/expanders etc., counter flanges with bolts, nuts, washers, temporary and permanent gaskets, threaded union etc. for all terminals of other packages as required.
 - c) Supply and machining work of flanges, pipe spools and matching pipes to connect flow measuring orifices/nozzles with the main pipe work.
 - d) All isolating and regulating valves, non-return valves, steam/air traps, relief/safety valves (wherever applicable), strainers, pressure reducing orifices etc. complete with the counter flanges and matching connecting pieces as required within the terminal points of entire low pressure piping system.
 - e) Anchors, hangers and supports, etc. as required. Any platform necessary for maintenance and operation of valve and equipment located 1.5 m above any permanent floor or platform with access ladders, supporting structures etc.
 - f) All secondary structural steel members required for pipe supports from building steel structures and from embedded steel wherever provided including pipe supports in trenches. However, trench piping should be avoided to the extent possible.
 - g) Funnels, tundishes for drips and drains including all miscellaneous drain piping and drain piping from tundish outlet up to drain points. All drain and vent lines shall be conveniently terminated to floor drain points/permanent drain trenches.
 - h) Flanges, counter flanges, blank flanges, bolts, nuts, washers, temporary and permanent gaskets, fasteners caps etc. as required for interconnecting piping, valves & fittings as well as for terminal points.
 - i) Cleaning and Painting of all piping, valves & specialties at manufacturer's shop.
- 3.02.00 Following general requirements shall however be included:





- a) Instrument Connections including instruments, root valves, sensing lines etc.
- b) Pipe stubs and blanking plates etc. required for chemical cleaning and hydro testing.

For conducting acceptance test, the required pressure, temperature, flow measurement points shall be provided.

3.03.00 All miscellaneous instruments as per approved P &ID during detail engineering stage.

3.04.00 For details regarding Scope of Services and works, Lead Specification Volume-IIA of this specification shall be referred.

3.05.00 **Terminal Points**

For terminal points, refer Volume-IIA (Lead Specification), Section-IV, of this specification.

4.00.00 **DESIGN AND CONSTRUCTION**

4.01.00 **General Considerations**

4.01.01 The piping systems included in this section shall be designed to operate continuously without replacement during the plant service life of 30 years.

4.01.02 The piping system shall be complete in every respect and in accordance with the highest standard of workmanship. Any item of the section on which the Bidder is in doubt shall be referred to the Owner for clarification.

4.01.03 All design and fabrication shall be in accordance with Codes / standards as specified.

4.01.04 No pipe work shall be run in trenches carrying electrical cables.

4.01.05 Pipe size above 50 NB shall be shop fabricated and of size 50 NB and below shall be field run.

4.01.06 All piping shall be identified by means of colour strips and by adequate lettering, conveniently spaced and located. Identification colours and lettering shall be as approved.

4.01.07 Air release and drain branches shall be provided wherever necessary depending upon the layout and arrangement so that the drains and air release valves are located for easy operation.

4.01.08 Unless otherwise specified, all pipe work shall be suitable for a minimum pressure of 10.0 kg/sq. cm(g) at 80°C or as required by the design of the different piping system, if higher.





- 4.01.09 **Drain Pipe work**
- a) Low pressure drains shall have an isolating valve at the point of take-off from the pipe or vessel to be drained, or as near as possible for conventional operation.
 - b) Unless otherwise stated, all drain piping shall be of 25 mm NB minimum and all vent pipings shall be of 15 mm NB size minimum. For pipes up to 50mm NB, pipe wall thickness shall be as per schedule 80 of ANSI B36.10.
 - c) Unless otherwise stated, wherever a main or branch of any pipeline is terminated with a valve, such terminal valve shall be provided with a blank flange/blanking cap at the free end.
- 4.01.10 Specification of pipes used in different services included in the L.P piping section has been detailed in Annexure-I of this section.
- 4.02.00 **Material Specification**
- 4.02.01 Materials for pipes and fittings shall be as stipulated in Annexure-I of this section. In case bidder wants to offer alternative piping material, same may be accepted by the Owner/Consultant provided the offered material is superior than the material specified for the intended service.
- 4.02.02 Pipe attachments for supports, anchors and restraints, which are coming in direct contact with pipes shall have similar materials as the piping concerned. All other materials of supports, anchors and restraints shall be of tested quality and as per manufacturer's standards.
- 4.03.00 **Fabrication**
- All pipes above 50 NB shall have butt-welded connections as per ANSI B 16.25 with a minimum of flanged joints necessary for maintenance. Piping of sizes 50 NB and below shall have socket welded connections as per ANSI B 16.11. Where flanges are adjacent to welded fittings, weld neck flanges shall be used.
- Branches shall, in general, be formed by welding. Standard fittings may be used in positions and for sizes where approval has been given in detail drawings. Pipe bends and tees shall be truly cylindrical and of uniform section. all welded branches shall be reinforced where needed as per the applicable codes/regulations.
- 4.03.01 Piping shall be fabricated in the shop in the largest transportable sections to minimise the number of field weld joints. The choice of field weld joints locations shall be based on the traverse of the pipe through walls, floors, sleeves or other restrictive areas. Support attachments for major piping shall be done at shop.
- 4.03.02 All pipe bends shall be made true to angle with no negative tolerance and shall have a smooth surface free of flat spots, crease and corrugations. A cross section through any bent portion of the pipe shall be true in diameter, within





plus or minus 3% of the pipe diameter. Pipe bends shall be made from straight pipe pieces of sufficiently higher thickness so that after thinning, the minimum thickness of bends shall not be less than the minimum thickness required for the straight pipe. Thinning allowance shall be considered as per the relevant Code.

4.03.03 For bends in pipes straight piece of pipes shall be bent by the Bidder to required bend radius. However, forged bends (Bend radius = 1.5 x pipe diameter) wherever required shall be provided at no extra cost.

4.03.04 The ends of Pipe and welded fittings shall be beveled according to details shown in the relevant piping code. All welding shall be made in such a manner that complete fusion and penetration are obtained without an excessive amount of filler metal beyond root area. The reinforcement shall be applied in such a manner that it shall have a smooth contour merging gradually with the surface of adjacent pipe and welded fittings. Backing rings shall not be used on any pipe welds, unless otherwise approved by the Owner.

4.03.05 **Cutting and Beveling**

a) Carbon steel piping - End preparation for butt welding shall be done by machining/flame cutting.

b) Socket welding - Socket weld and preparation shall be done by saw or machine cutting.

4.04.00 **Hangers, Supports, Anchors**

Normally pipe supports and anchors shall be selected at those points in the buildings where provision has been made for the loads imposed. The cutting of floor/roof beams or the reinforcement in slabs will not be permitted. Piping attached to a plant item shall be supported in such a way that the weight of the piping is not taken by the plant item.

4.04.01 Support spacing shall be as per good engineering practice. However in no case it shall be less than support spacing stipulated in ANSI B31.1.

4.04.02 Accurate weight balance calculations shall be made to determine the required supporting force at each hanger location and the pipe weight load at each equipment connection.

4.04.03 All large pipes and all long pipes shall have at least two supports each arranged so that any length of pipe or valve may be removed without any additional supports being required.

4.04.04 Support steel shall be of structural quality. Perforated strap, wire or chain shall not be used. Support components shall be connected to support steel by welding, by bolting or by beam clamps. Bolt holes shall be drilled, not burned. Support components may be bolted to concrete using approved concrete anchors.

4.05.00 **Valves and Accessories**





4.05.01

General Requirements

- a) All valves shall be of approved make and type and shall have cast/forged bodies with covers and glands of approved construction and materials as specified in Annexures-II & III of this section. The valves shall be provided with electric motors/solenoids and actuators as required.
- b) Valves and specialties to be supplied under this section will be used for various air and water services and will be located indoor/outdoor and on horizontal/vertical runs of the pipelines. However, mounting of valves in vertical pipe runs should be avoided as far as possible.
- c) All valves shall, unless otherwise stated, have the internal diameter same as the internal diameter of the pipes to be joined.
- d) Material, design, manufacture, testing etc. for all valves and specialties along with the accessories shall conform to the latest editions of codes
- e) Gate valve and Ball valve have been specified with the intention of achieving isolation and tight shut-off. In full open condition, these valves should offer minimum of resistance to fluid flow.
- f) Globe valves have been specified with the intention of achieving good control of fluid passing. The plug and seat will have therefore suitable profiles for obtaining such controlling action.
- g) Check valves have been specified in order to prevent reverse flow through them.
- h) All valves shall function smoothly without sticking, rubbing or vibration on opening or closing and shall be suitable for most stringent service conditions i.e. flow, temperature and pressure under which they may be required to operate.
- i) By pass valves shall be provided for larger size valves as per standards followed and as felt necessary for smooth and easy operation, even though not specifically mentioned in the specification.
- j) All flanged valves and specialties to be supplied under this section shall be provided with two (2) counter flanges, bolts, nuts, washers, gaskets etc.
- k) All valves shall be of proven design and manufacture. Where valves are of similar size and type they shall be interchangeable with one another. Valves shall have welded or flanged connections subject to the Owner's approval.
- l) All valves shall have outside screwed spindles and screwed thread of spindle shall not pass through or into the stuffing box. Where valves are





exposed to the weather, protective covers shall be provided for the spindles, which shall be subject to approval.

- m) Gate, Globe and Ball valves shall be provided with the following accessories in addition to other standard items:
 - i) Hand wheel with embossed open and shut directions.
 - ii) Local position indicator.
 - iii) Motorised operation as specified by Owner/Consultant.
- n) Gate valves, in addition shall be provided with following extra features :
 - i) Bypass valve for larger valves.
 - ii) Draining arrangement.
 - iii) Gear operators for valves 300 mm size and above for ease in operation.
 - iv) Motorised operation as specified by Owner/Consultant.
- o) All gate and globe valves shall be rising stem type.
- p) All valves shall be provided with hand-wheels, chain, operator, extended spindle and floor stand wherever required so that they can be operated manually by a single operator from the nearest operating floor either at a lower or higher elevation as the case may be. If such a valve is provided with integral bypass then similar arrangement shall be done for the bypass valve also.
- q) All valves and specialties shall be provided with brass Tag Discs indicating Tag numbers and nomenclature of the valve including duty or service intended and the function of the valves specialties.
- r) Stems shall preferably be arranged vertically with gland at the top, however, in no circumstances must the stem be inclined downward from horizontal or gland be at the bottom. Globe valves shall be installed with the pressure under the disc. Valves shall not be fitted in inverted position.
- s) Where necessary, for accessibility, grease nipples shall be fitted at the end of extension piping and where possible these shall be grouped together and mounted on a common panel situated at a convenient position. A separate nipple shall be provided to lubricate each point. The Bidder shall supply the first fill of oil or grease for these parts. The Bidder shall supply a suitable manually operated grease gun for the standard type of nipple provided.
- t) The spindles for all valves for use outside the building shall have weatherproof protection covers of approved construction.
- u) All valves shall be fitted with indicators so that it may be readily seen whether the valves are open or shut. In the case of those valves fitted



with extended spindles, indicators shall be fitted both to the extended spindles and to the valve spindles.

- v) Plastic or bakelite valve hand wheels will not be accepted.
- w) All valves shall be closed by rotating the hand wheel in a clockwise direction when looking at the faces of the hand wheel. The face of each hand wheel shall be clearly marked with the words 'Open' and 'Shut' with arrows adjacent to indicate the direction of rotation to which each refers.
- x) Wherever practicable heavy valves of total weight including actuator, drive motor, integral by-pass etc., equal to or greater than 500 kg. shall be provided with suitable lugs to permit direct suspension by hanger rod or direct resting on bottom support, as applicable.
- y) Special attention shall be given to the operating mechanism for large size valves in order that quick and easy operation is obtained and maintenance is kept to a minimum.
- z) Eyebolts shall be provided where necessary to facilitate handling heavy valves or parts of valves.
- aa) The Bidder shall supply with his bid and in addition during the course of the Contract, comprehensive drawings showing the design of valves, test pressure and working pressure/temperatures. They should include a parts list referring to the various materials used in the valve construction.
- bb) All sampling and root valves shall be of integral body bonnet type.

4.05.02 For Design Requirements for different valves please refer Annexure-II & III of this section.

4.06.00 **Safety/Relief Valves**

Safety/Relief valves shall be of direct spring loaded type and shall have a tight, positive and precision closing.

All safety valves shall be provided with manual lifting lever.

Valves used for air and any other compressive fluid shall be of pop type.

Safety/Relief valves shall be constructed and adjusted to permit the fluid to escape without increasing the pressure beyond 10% above the set blow off pressure. Valve shall reset at a pressure not less than 2.5% and more than 5% of the set pressure.

Releasing capacity of the safety/relief valves shall be as per the applicable codes and standards and shall be subject to the approval of the Owner/Consultant.





The seat and disk of safety valves shall be of suitable material to resist erosion. The seat of valve shall be fastened to the body of the valve in such a way that there is no possibility of the seat lifting.

4.07.00 **Hose pipe and Accessories**

4.07.01 Hose valves for service water system shall be Gate valves and service air system shall be Globe valves.

4.07.02 Hose pipes with fittings for Service Water System:

- a) The water hose shall be as per IS-444 (Type-3).
- b) Length of each hose shall be 15 metres.
- c) For each hose, one end shall be fitted with M.S. female coupling with swiveling nuts and soft seating ring suitable for connection to male end of hose valve and other end shall be made threaded for joining with the swiveling nut of a second hose whereby two hose lengths may be joined.

4.07.03 **Hose pipes with fittings for Compressed air System**

- a) The compressed air hose shall be as per IS-911 (Type 2).
- b) The length and type of each end shall be similar to as specified in above clause no. (b & c) above.

5.00.00 **INSTALLATION**

5.01.00 All fittings like "T" pieces, flanges, reducers etc. shall be suitably matched with pipes for welding. The valves will have to be checked, cleaned or overhauled in full or in part before erection, after chemical cleaning and during commissioning.

5.02.00 Adjustments like removal of oval ties in pipes and opening or closing the fabricated bends of high pressure piping to suit the layout shall be considered part of work and the Erection Bidder is required to carry out such work as per instruction of Bidder/Owner, which shall include specified heat-treatment procedures, etc. also wherever required.

5.03.00 Certain adjustments in length may be necessary while erecting high pressure pipelines and the Contractor should remove the extra lengths to suit the final layout after preparing edges afresh and adopting specified heat treatment procedures.

5.04.00 Suspension for piping, pressure parts, etc., will be supplied in running lengths, which shall be cut to suitable sizes and adjusted as required.

5.05.00 All the valves, lifting equipments, actuators, power cylinders, etc., shall be serviced and lubricated to the satisfaction of Owner before erecting the same and also during pre- commissioning. Even after commissioning, the equipments, if there are problems in the operation, they have to be attended to by the Bidder





during the tenure of the contract. Welding or jointing of extension spindle for valves to suit the site conditions and operational flexibility shall be part of erection work.

- 5.06.00 All tubes and pipes shall be cleaned and blown with compressed air and shown to the Owner before lifting. Bigger size pipes should be cleaned with flexible wire brush, wherever necessary. After cleaning is over the end caps shall be put back in tube openings till such time they are welded to other tubes.
- 5.07.00 Fine fittings, drain piping, oil systems & other small bore piping have to be routed according to site conditions and hence shall be done only in position. As such, layout of small-bore piping shall be done as per site requirement. There is a possibility of slight change in routing the above pipelines even after completion of erection, which shall be carried out by the Bidder without any extra cost to the Owner. Work shall also include fabrication of small bends at site from straight lengths to suit the site conditions.
- 5.08.00 Welding of temporary supports, cleats, etc., on the building columns shall also be avoided. In case of absolute necessity, Erection Bidder shall take prior approval from Bidder/Owner. Further, any cutting or alteration of member of the structure or platform or other equipments shall not be done without specific prior approval of Owner.
- 5.09.00 Wherever piping erected by the Erection Bidder is connected to piping or equipment erected by some other agencies the joint at the connecting point shall be considered under this specification.
- 5.10.00
- a) All piping shall be grouped wherever practicable and shall be routed to present a neat appearance.
 - b) The piping shall be arranged to provide clearance for the removal of equipment for maintenance and for easy access to valves, instruments and other piping accessories required for operational maintenance.
 - c) Piping shall be routed above ground unless otherwise specifically indicated/ approved by the Owner. In such special case, the piping may be arranged in trenches, or buried and properly protected as per AWWA Standards.
 - d) Overhead piping shall have a minimum overhead clearance of 2.5 meters above walkways and working areas and 8 meters above roadways unless otherwise approved by the Owner.
 - e) Drains shall be provided at all low points and vents at high points as per actual layout regardless of whether some have been shown in respective Tenders drawings or not. The pipelines shall be sloped towards the drain points.
- 5.11.00 All drips and drains for piping and equipment whether shown in the Tender drawings or not shall terminate on the ground floor up to station drain unless otherwise specified. Leading such drains up to station drainage is also the responsibility of the Bidder.
- 6.00.00 **DRAWING, DATA AND INFORMATION REQUIRED**





- 6.01.00 Drawings, data, Information to be furnished by the Bidder besides those already mentioned in Volume-IIA (Lead Specification) with the offer.
- 6.01.01 A complete list of all piping and fittings of various sizes with their quantities and details e.g. nominal size, O.D., I.D. (as applicable) thickness, design pressure, design temperature, material of construction/code/standards etc.
- 6.01.02 A complete list of all valves with their type, quantities & ratings.
- 6.01.03 Manufacturer's catalogue indicating complete range of available size and rating of pipes & fittings.
- 6.01.04 Descriptive literature on the manufacturing process and quality control procedures highlighting the manufacturing, fabricating and testing facilities available in the shop.
- 6.02.00 After Award of Contract**
- Detail drawings including fabrication drawings of all shop fabricated piping system indicating design parameters and complete bill of material (Relevant Standards and grades to be indicated) and information/data pertaining to the hydrostatic and non-destructive test requirements to be submitted progressively.
- 6.02.01 Detail dimensioned drawing of each valve, specialties, indicating tag no., pressure rating, manufacturing standard, the bill of materials and hydrostatic test pressures. The drawing shall include the end preparation details and shall indicate the position of the hand wheel/operator. Technical particulars of motor operators wherever applicable shall also be indicated.
- 6.02.02 General arrangement drawing for each hanger/support/anchor etc. indicating identification number, auxiliary supporting structural details, other details & information as required in the specification.
- 6.02.03 Wiring diagram for all limit switches of motor operated valves.
- 6.02.04 The loading data required for design of structures shall be furnished well in advance to suit Owner's project schedule.



Tender Specification
for
FGD Package

NLC Tamil Nadu Power Ltd.
2x500 MW Project
Tuticorin, Tamil Nadu

ANNEXURE-I

SPECIFICATION OF PIPES & FITTINGS

Sl. No.	Services	Slurry Piping	Service Water and Demineralised Cooling Water	Drinking Water (chlorinated)	Service and Instrument Air	Auxiliary Steam
1.0	Material of Pipe					
a)	Above 150 mm NB	IS-3589 with minimum pipe thickness of 6 mm and 5 mm thick rubber lining.	IS-3589 with minimum pipe thickness of 6 mm	IS-3589 with minimum pipe thickness of 6 mm, galvanized as per IS-4736	Stainless steel as per ASTM A-312 Gr. 304 as per schedule 10S, ANSI B-36.19.	Carbon Steel, ASTM A-106, Gr. B or C.
b)	80 to 150 mm NB	IS-1239 Heavy Grade with 5 mm thick rubber lining	IS-1239 Heavy Grade	IS-1239 Heavy Grade, galvanized as per IS-4736		
c)	Below 80 mm NB	FRP			Stainless Steel as per ASTM A-312 Gr. 304 as per schedule 40S ANSI B36.19	
2.0	Construction	ERW / Seamless	ERW / Seamless	ERW / Seamless	Seamless	Seamless
3.0	Joints			Pipe to pipe joint shall be with union as per IS:1239, Part-II.		
a)	65 mm NB and above	Flanged	Slip on Flange / butt weld	Screwed flange	Slip on Flange / butt weld	Slip on Flange / butt weld
b)	size 50 mm NB and below.		Socket weld	Screwed socket	Socket weld	Socket weld
4.0	Fittings					
4.1	Materials					



Development Consultants Pvt. Ltd.

Vol. II-D/Section-I
Piping, Valves & Specialties



**Tender Specification
for
FGD Package**

NLC Tamil Nadu Power Ltd.
2x500 MW Project
Tuticorin, Tamil Nadu

ANNEXURE-I

Sl. No.	Services	Slurry Piping	Service Water and Demineralised Cooling Water	Drinking Water (chlorinated)	Service and Instrument Air	Auxiliary Steam
a)	Pipe Sizes \geq 65 mm NB	ASTM-A-234 Gr. WPB with 5 mm thick rubber lining.	ASTM-A-234 Gr. WPB	ASTM-A-234 Gr. WPB galvanized as per IS-4736	ASTM-A-351-CF8 or ASTM-A-403 WP304	ASTM-A-234 Gr. WPB
b)	Pipe Sizes \leq 50 mm NB	FRP	ASTM-A-105 or as compatible with IS:1239	ASTM-A-105 or as compatible with IS:1239 and galvanised as per IS-4736	ASTM-A-182 F304	ASTM-A-105
4.2	Construction	Welded/ Seamless				
a)	Pipe Sizes \geq 65 mm NB		Welded/ Seamless	Welded/ Seamless	Welded/ Seamless	Welded/ Seamless
b)	Pipe Sizes \leq 50 mm NB		Forged	Forged	Forged	Forged
4.3	Standard					
a)	Above 150 mm NB	ANSI-B-16.9/ For fabricated fitting AWWA-C-208	ANSI-B-16.9 / For fabricated fitting AWWA-C-208	ANSI-B-16.9	MSS-SP-43	ANSI-B-16.9
b)	80 to 150 mm NB	ANSI-B-16.11 or IS:1239, Part-II	ANSI-B-16.11 or IS:1239, Part-II	ANSI-B-16.11 or IS:1239, Part-II		
c)	Below 80 mm NB	As per applicable manufacturer's standard.			ANSI-B-16.11	ANSI-B-16.11
4.4	End details					
a)	Pipe Sizes \geq 65 mm NB	Flanged	Butt welded as per ANSI-B-16.25	Screwed Flanged.	Slip - on flanges as per ANSI B16.5. Butt welded for Pipe fittings	Butt welded as per ANSI-B-16.25



Development Consultants Pvt. Ltd.

Vol. II-D/Section-I
Piping, Valves & Specialties



Tender Specification
for
FGD Package

NLC Tamil Nadu Power Ltd.
2x500 MW Project
Tuticorin, Tamil Nadu

ANNEXURE-I

Sl. No.	Services	Slurry Piping	Service Water and Demineralised Cooling Water	Drinking Water (chlorinated)	Service and Instrument Air	Auxiliary Steam
					and flanged for valves and equipments.	
b)	Pipe Sizes \leq 50 mm NB		Socket welded as per ANSI-B-16.11	Screwed socketed as per ANSI-B-16.11 or IS:1239, Part-II	Socket welded as per ANSE B16.11	Socket welded as per ANSI-B-16.11
5.0	Flanges	Applicable class as per ANSI-B-16.5 complete with nuts, bolts and gaskets	150 lb class as per ANSI-B-16.5 complete with nuts, bolts and gaskets	As per ANSI-B-16.5 pressure class 150lbs - galvanised- complete with nuts, bolts and gaskets.	As per ANSI-B-16.5, 150lb pressure class complete with nuts, bolts and gaskets. Material as per class 4.01.00.	Applicable class as per ANSI-B-16.5 complete with nuts, bolts and gaskets
Pipes shall be hydrostatically tested according to the said code, for other Codes please refer Volume-IIA (Lead Specification), Section-V of this specification.						

Note:

- 1) Piping system not covered in above table shall be as per Vendor's proven practice, subject to approval by Purchaser
- 2) For waste water handling system, all piping and fittings shall be HDPE material.



Development Consultants Pvt. Ltd.

Vol. II-D/Section-I
Piping, Valves & Specialties



ANNEXURE-II

SERVICES OF VARIOUS CATEGORIES OF VALVES

Valve Classification		Service		
A.	Cast iron body Gate/Globe/Check Valve	i)	Service Water (Clarified).	For sizes 65 mm NB to 300 mm NB.
		ii)	Drinking Water.	
B.	Stainless steel body Ball/ Check Valve	i)	Service and Instrument Air.	For all sizes.
C.	Steel Body Gate/ Globe/ Check Valves	i)	Service Water (Clarified).	For sizes less than and equal to 50 mm NB.
		ii)	Drinking Water	
		iii)	Auxiliary Steam	For all sizes
		iv)	Inhibited Demineralised Water for DMCW system	
D.	Cast Iron body butterfly valve		Service Water (Clarified).	For sizes above 300 mm NB
E.	Cast Steel Knife Gate/ Butterfly valves with rubber lining		Limestone/ Gypsum Slurry	For all sizes



Tender Specification
for
FGD Package

NLC Tamil Nadu Power Ltd.
2x500 MW Project
Tuticorin, Tamil Nadu

ANNEXURE-III

SPECIFICATION OF GATE/GLOBE/CHECK/BALL VALVES

Sl. No.	Description	A. Cast Iron Body Gate/ Globe/Check Valve	B. Stainless steel Body Check/Ball Valve	C. Steel Body Gate/ Globe/Check Valve
1.0	Valve Classification Code	CIGC	SSGC	STGC
2.0	Basic Design Code			
2.1	Gate	i) IS 780 for 50 mm - 300 mm NB ii) IS2906 for 350 mm NB and above or as per MSS-SP-70		i) API 600 for 50mm NB and above /ANSI-B-16.34 ii) API 602 for size below 50mm NB/ANSI-B-16.34
2.2	Globe	MSS - SP - 85		BS-1873/ANSI-B-16.34
2.3	Check	IS-5312/MSS - SP -71	ANSI-B-16.34	BS-1868/ANSI B16.34
2.4	Ball		BS-5351	
3.0	Pressure Class	To be suitably chosen considering the pressure requirement. Refer Clause No. 4.01.08 in this regard.		
4.0	Construction	Cast body and bonnet / cover.	Forged body up to 50mm NB and Cast body above that.	
5.0	Material			
5.1	Body & Bonnet/ cover	IS 210 Gr. FG 260 or ASTM A216 Class B.	i) ASTM-A-182 F304 for Ball Valves ii) A351 CF8M for cast body check valves, ball valves iii) A 182 F304 for forged body check valves.	i) ASTM-A-216 Gr. WCB for cast body valves ii) ASTM-A-105 for forged body valves.
5.2	Trim / Disc.	IS-210 Gr. FG 260 or ASTM A216 Class B.	i) ASTM-A-182 F304 for Check valves ii) 351CF 8M for Ball valves.	i) 13% Cr Steel as per ASTM-A-182 Gr. F6 heat treated and hardened (min 250 HB) for cast body ii) ASTM-A-105 Hard faced



Development Consultants Pvt. Ltd.

Vol. II-D/Section-I
Piping, Valves & Specialties



Tender Specification
for
FGD Package

NLC Tamil Nadu Power Ltd.
2x500 MW Project
Tuticorin, Tamil Nadu

ANNEXURE-III

Sl. No.	Description	A. Cast Iron Body Gate/ Globe/Check Valve	B. Stainless steel Body Check/Ball Valve	C. Steel Body Gate/ Globe/Check Valve
				with Stellite (min 350 HB) for forged body.
5.3	Seating surface	13% Cr steel as per IS 1570.	For Ball valves PTFE seats and seals.	13% Cr. Steel as per ASTM- A-182 Gr. F6
6.0	End Preparation	Socket welded for size equal to and below 50 mm NB and flanged with counter flanges for 65 mm NB and above.		
7.0	Testing			
	a) Gate	i) As per IS - 780 for 50 mm - 300 mm NB	As per ANSI B-16.34	API-598
		ii) IS-2906 for sizes equal to and above 350 mm NB		
	b) Globe	Hydrostatic Test as per MSS-SP- 85		BS-1873
	c) Check	IS-5312/MSS-SP-71		BS--1868

Note: For Waste water handling system, all valves shall be duplex stainless material.



Development Consultants Pvt. Ltd.

Vol. II-D/Section-I
Piping, Valves & Specialties



ANNEXURE-IV

SPECIFICATION OF BUTTERFLY VALVE

1.0	Valve classification Code	: CIBF
2.0	Basic Design Code	: AWWA-C-504
3.0	Pressure	: To be suitably chosen by the Bidder according to requirement, but not less than class 75A as per AWWA-C-504.
4.0	Construction	: Cast Body and Disc
5.0	Material	
	a) Body	: 2% Ni Cast Iron as per IS-210 Gr. FG260 with 2% Ni.
	b) Valve Disc	: -Do-
	c) Valve Shaft	: Stainless Steel ASTM-A-479 type 304
	d) Seat ring	: Clamping ring Stainless Steel ASTM-A-479 type 304
	e) Shaft Bearing	: Ferrobestos LA-33
	f) Gland Packing	: Impregnated Teflon
	g) Seal	: Nitrile Rubber
6.0	End preparation	: Flanged, Drilled as per ANSI B16.1. Necessary counter flange nuts, bolts, gaskets are to be provided with each valve.
7.0	Testing	: As per AWWA-C-504. However valve disc strength for both forward reverse flow is to be carried out as per BS 5155. Certificate for proof of design test for similar type of valve is to be furnished.

Note:

- 1) For Slurry lines rubber lining/EPDM/equivalent protection to be provided.
- 2) For Waste water handling system, all valves shall be duplex stainless material.



714945/2022/PS-PEM-MAX



2X500 MW NTPL TUTICORIN FGD

COMPRESSED AIR SYSTEM

SPECIFICATION No: PE-TS-483-555-A002

VOLUME: II B

SECTION : C2-B

REV. 00

DATE: FEB 2022

SHEET: 1 OF 1

SECTION: C2-B

PROJECT SPECIFIC GENERAL REQUIREMENTS



VOLUME : II-A
SECTION - IV
GENERAL TECHNICAL REQUIREMENTS





CONTENTS

CLAUSE NO.	DESCRIPTION	PAGE NO.
1.00.00	CODES AND STANDARDS	1
2.00.00	DESIGN CRITERIA	2
3.00.00	REDUNDANCY	3
4.00.00	NAME PLATES / RATING PLATES / LABELS	3
5.00.00	SAFETY AND SECURITY	5
6.00.00	GUARDS	5
7.00.00	LOCATION AND LAYOUT REQUIREMENTS	6
8.00.00	OPERATION AND MAINTENANCE CONSIDERATIONS	8
9.00.00	MATERIALS	9
10.00.00	LUBRICATION	10
11.00.00	LUBRICANTS, SERVO FLUIDS AND CHEMICALS	10
12.00.00	PLANT LIFE AND MODE OF OPERATION	11
13.00.00	PACKAGING & MARKING	11
14.00.00	PROTECTION	12
15.00.00	PAINTING	13
16.00.00	COLOUR CO-ORDINATION AND FINISH	13
17.00.00	ENVIRONMENT PROTECTION AND NOISE LEVEL REQUIREMENT	13
18.00.00	INSPECTION AND TESTING	15
19.00.00	TRAINING OF OWNER'S PERSONNEL	16
ATTACHMENTS		
ANNEXURE-I	LIST OF STANDARDS FOR REFERENCE	19
ANNEXURE-II	CRITERIA FOR LAYOUT	21





VOLUME : II-A

SECTION - IV

GENERAL TECHNICAL REQUIREMENTS

1.00.00 CODES AND STANDARDS

- 1.01.00 Except where otherwise specified, the design of FGD Plant package shall comply with the appropriate Indian Standard or an agreed internationally accepted Standard Specification as listed in the Annexure-I to this Section and mentioned in detailed specifications, each incorporating the latest revisions at the time of tendering. Where no internationally accepted standard is applicable, the Bidder shall give all particulars and details as necessary; to enable the Owner to identify all of the FGD Plant package in the same detail as would be possible had there been a Standard Specification.
- 1.02.00 The Bidder shall submit along with his bid the list of main codes and standards proposed to be used for the design, construction and testing of the plant. Where the Bidder proposes alternative codes or standards in place of those mentioned in this technical specification, he shall include in his tender one copy (in English) of each Standard Specification to which materials offered shall comply. In such case, the adopted alternative standard shall be equivalent or superior to the standards mentioned in the specification.
- 1.03.00 Wherever specified or required to the FGD Plant package shall conform to all applicable statutory regulations such as Indian Boiler Regulations, Indian Electricity Rules, Indian Explosives Act, Factories Act etc. Wherever required, approval for the FGD Plant package supplied under the specification from statutory authorities shall be the responsibility of the Bidder.
- 1.04.00 In the event of any conflict between the codes and standards referred above, and the requirements of this specification, the requirements, which are more stringent, shall govern. And if they are equally stringent, the Bidder shall follow the hierarchy as follows:
- i) Local regulations
 - ii) Local codes and standards
 - iii) This Technical Specifications
 - iv) Industry codes and standards
- 1.05.00 In case of any change of code, standards and regulations between the date of purchase order and the date the Bidder proceeds with manufacturing the Owner shall have the option to incorporate the changed requirements. It shall be the responsibility of the Bidder to bring such changes to the notice of the Owner and advise Owner of the resulting effect.





**Tender Specification
for
FGD Package**

**NLC Tamil Nadu Power Ltd.
2x500 MW Project
Tuticorin, Tamil Nadu**

1.06.00 Combining or mixing of codes and standards of different institutions with respect to individual engineered components/equipments shall not be permitted without the written approval of the Owner.

2.00.00 DESIGN CRITERIA

2.01.00 Capability

The Flue Gas Desulphurisation (FGD) System shall be designed to comply with the design and guarantee point conditions mentioned below and should achieve Sulphur Dioxide (SO₂) level of not exceeding 150 mg/Nm³ and 150 mg/Nm³ respectively at 6% excess oxygen level at the stack outlet under all plant operating conditions. The SO₂ removal efficiency shall not be less than 95 % under all operating condition. These shall be modified to more conservative values if Contractor experience warrants the same. However, no credit shall be given to the Contractor for this during evaluation of the bids. Utilization of these values in no way relieves the Contractor of his responsibility to meet all the guarantee requirements.

- a) Design Point : BMCR load with worst Coal, 45 deg.C and 60% RH ambient condition
- b) Guarantee Point : TMCR load with worst Coal, 27deg.C and 60% RH ambient condition

2.02.00 Equipment Sizing Margins

The following equipment sizing design margins shall be used, as a minimum, based on normal operation of the plant (2x500MW at TMCR) with Coal having highest Sulphur content unless other margins are specified in this Design Specifications.

Equipment/ System	Mass Flow Margin	Pressure Margin
Absorber (gas and slurry)	10%	NA
Limestone Grinding system	10%	NA
Gypsum Dewatering System	10%	NA
Hydro-cyclone	10%	NA
Pumps	10% min.	15% (friction losses)
Blowers/Compressors/ Vacuum pumps	10% min.	10%
Conveyors	10% min.	NA
Crushers	20% min.	NA
Flue Gas Booster Fans	20%	44%





**Tender Specification
for
FGD Package**

**NLC Tamil Nadu Power Ltd.
2x500 MW Project
Tuticorin, Tamil Nadu**

- 2.03.00 Off-normal operation
- 2.03.01 The FGD system shall also be capable of operating with partial bypass of flue gas.
- 2.03.02 The flue gas temperature at inlet to FGD shall be about 175⁰C. However, in case of APH failure the flue gas temperature may rise to about 375⁰C for a short duration and the FGD system shall be designed to suitably withstand such operation without any damage to the system.
- 2.03.03 The FGD plant shall be capable of following the load imposed by the boiler, including rate of load changes, minimum load and the anticipated daily and annual load schedules. Furthermore, the FGD plant shall be capable to be put in operation, while the boiler is in operation at any load, without any disturbance in the operation of the Units.
- 3.00.00 REDUNDANCY**
- 3.01.00 Redundancy of design shall be such that the performance of primary and auxiliary equipment shall be sufficient to meet the availability requirements of the plant.
- 3.02.00 Each equipment whose failure could result in damages to another equipment, or reduce the availability of the plant shall be backed up by a stand-by equipment.
- 3.03.00 Each equipment whose unavailability due to a failure could result in damages to another equipment or create a health & safety risk for the personnel shall be backed up by a stand-by equipment, one of them being fed by an emergency source in case of external black out.
- 3.04.00 Design of availability of the FGD Plant equipment & auxiliaries will be such that a failure with consequential shutdown of one Absorber & auxiliaries will in no circumstances be at the origin of a shutdown of the other Absorber & auxiliaries.
- 3.05.00 Redundancy criteria applicable for specific systems have been addressed in respective sections of the specification (Volume IIB to II-I) and tender drawings (Volume IIJ).
- 4.00.00 NAME PLATES/ RATING PLATES/ LABELS**
- 4.01.00 Instruction plates, nameplates (rating plates) or labels shall be permanently attached to each main and auxiliary item of FGD Plant equipment & auxiliaries, including instruments, in a conspicuous position. These plates shall be of stainless steel and shall be engraved with the identifying name, type, identification number and manufacturer's serial number, together with the loading conditions under which the item of plant has been designed to operate.





**Tender Specification
for
FGD Package**

**NLC Tamil Nadu Power Ltd.
2x500 MW Project
Tuticorin, Tamil Nadu**

- 4.02.00 Items such as valves, etc. which are subject to hand operation, shall be provided with nameplates so constructed as to remain clearly legible throughout the life of the plant giving due consideration to the difficult climatic conditions to be encountered. Nameplates shall be securely mounted where they will not be obscured in service by insulation, cladding, actuators or other equipment. Bidder shall pay specific attention to the nameplates/labels during painting, so that these are not painted over. Direction of flow is also to be engraved. All actuated valves shall be provided with labels, which shall include the valve and actuator reference number.
- 4.03.00 All nameplates and labels shall be in English language. All measurements shall be in S.I. units.
- 4.04.00 All segregated phases of conductors or bus ducts, indoor or outdoor, shall be provided with coloured phase plates to clearly identify the phase of the system.
- 4.05.00 Nameplates shall be 3 mm thick laminated white, black, white traffolyte for electrical and control panels and stamped stainless steel with lettering of a minimum height 5 mm for other equipment of FGD Plant Equipment & auxiliaries. Warning labels and emergency equipments shall have red lettering in place of black. Danger labels shall have red lettering on a white background. Labels shall be of sufficient size to carry a full description of the FGD Plant item and its complete KKS identifier. The size and location of nameplates shall be subject to Approval of the Owner. Lettering in all cases shall be machine-made and made to be legible after prolonged time in the range of ambient conditions prevailing at the Site.
- 4.06.00 Universal designation system utilizing six level breakdown KKS numbering system shall be followed for equipment identification. Each piece of equipment, motor, pump, valve, instrument, switchgear cabinet, junction box, control panel, panel board and associated apparatus shall be provided with tag plates indicating tag number and description. All major equipment (including the absorber, hydrocyclone, ball mills, belt filters, auxiliary transformers, booster fans, large pumps and blowers and motors) shall be provided with the data plates, indicating the name of the vendor, type, serial number, year of fabrication, main characteristics, and all further information necessary for a complete identification of the equipment.
- 4.07.00 All piping shall be painted and/or marked in accordance with the fluid contained according to a power plant color code to be proposed by Bidder and approved by Owner.
- 4.08.00 Tags shall be fitted by stainless steel self-tapping screws, stainless steel banding such that they are not readily lost or broken during routine operations and maintenance.
- 4.09.00 Surfaces of labels for cubicles and control equipment shall have a matte or satin finish to avoid dazzle. Colors shall be permanent and free from fading. Danger labels shall have red lettering on a white background. Labels shall be





provided on front and rear access doors of all cubicles. Labels shall also be provided inside cubicles to assist the identification of apparatus and terminals.

4.10.00 All lifting beams, cranes, rails, jibs, hoists, slings, straps and other lifting equipment shall be properly tested and permanently marked with their lifting capacity.

5.00.00 SAFETY AND SECURITY

5.01.00 The design shall incorporate every reasonable precaution and provision for the safety of all personnel and for the safety and security of all persons and property. The design shall comply with all appropriate statutory regulations relating to safety. All structures and equipment shall be designed and constructed to withstand every foreseeable static and dynamic loading condition, including loading under earthquake conditions, with an adequate margin of safety.

5.02.00 Ready and safe access with clear head room shall be provided to all parts of the FGD Plant Equipment & auxiliaries for operation, inspection, cleaning and maintenance. All platforms shall be fenced and all stairways shall be provided with handrails.

5.03.00 Escape routes and clear ways shall be provided to allow speedy evacuation of the personals in the event of fire or explosion, and the plant layout shall allow for ease of access to all parts of the Works by rescue and fire fighting teams. The FGD Plant Equipment & auxiliaries layout shall be designed to localise and minimise the effects of any fire or explosion. The recommendations of NFPA, OSHA, etc. as necessary shall be followed in all respects.

5.04.00 The use of corrosive, explosive, toxic or otherwise hazardous materials shall be kept to a minimum during construction and the design of the plant shall minimise the requirement for such materials during operation and maintenance. Where such materials must be used, all necessary precautions shall be taken in the design, manufacture and layout of equipment to minimise the resulting hazard, and all equipment necessary for the protection and first-aid treatment of personnel in the event of accidents shall be provided. Particular attention is drawn to avoid the use of prohibited materials in any form as mentioned elsewhere in this specification.

6.00.00 GUARDS

6.01.00 Effective guards and fences must be provided to prevent injury to operators through accident or malpractice.

6.02.00 Mesh guards which allow visual inspection of equipment with the guard in place are generally preferable. The guards shall be constructed of mesh attached to a rigid framework of mild steel rod, tube, or angle and the whole galvanised to prevent loss of strength by rusting or corrosion. The guards shall be designed to facilitate removal and replacement during maintenance.





- 6.03.00 All drive belts, couplings, gears, sharp metallic edges and chains must be safely guarded. Any lubricating nipple requiring attention during normal running must be positioned where they can be reached without moving the guards.
- 6.04.00 Guards for couplings and rotating shafts shall be in accordance with latest revisions of BS PD 5304-2005/ BS EN 953-1998 or similar approved standard. All rotating shafts and parts of shafts must be covered.
- 6.05.00 Suitable fencing shall be provided to enclose all openings or doorways used for the hoisting and lowering of machinery etc. This fencing must be securely fixed but quickly detachable when required. A secure hand hold must be provided on each side of the opening or doorway.

7.00.00 LOCATION AND LAYOUT REQUIREMENTS

The majority of FGD Plant Equipment & auxiliaries (excluding Absorber and DG sets) shall all be of indoor installation. A broad list of buildings housing such equipment is given elsewhere in this specification. Layout should facilitate access for operation-maintenance and inspection of any one or more equipment/components at a time without disturbing the operation or installation of rest of the FGD Plant Equipment & auxiliaries. Further, Bidder should comply with the criteria given under the various equipment and system specifications as well as those stipulated in Annexure-II attached to this section.

Enclosed General Layout drawings show the location of major facilities. The Bidder shall try to retain these locations as far as practicable. The layout of equipment within the FGD area as shown in the tender drawings is indicative. The Bidder may, subject to Owner's approval alter the same to suit the space requirement of the equipment offered.

Bidder may give alternate layout of their own with different orientation and relocation but all the equipments and facilities as in tender drawing/specification should be covered and the overall BTG area layout as shown in tender drawing is to be maintained.

While preparing the detailed layout and deciding upon the transportation and construction/ erection strategy and functional requirements, the following aspects shall be ensured:

- a) Face of the buildings and facilities shall be located in such a way so as to have an offset of minimum 20 m with respect to center line of double lane road and 15 meter with respect to center line of single lane road.
- b) The spacing between various buildings and facilities shall be suitably decided so as to avoid interference between the foundations.





**Tender Specification
for
FGD Package**

**NLC Tamil Nadu Power Ltd.
2x500 MW Project
Tuticorin, Tamil Nadu**

- c) The area for construction/erection facilities like lay-down, pre-assembly, offices and stores will be accommodated within the areas available in General Layout Plan.
- d) All statutory requirements including safe distances between various facilities as per applicable rules/acts/laws including local by-laws will be complied with.
- e) Minimum clearances/ dimensions
- | | | |
|------|--|--------------------|
| i) | Around the equipment | : 1200mm |
| ii) | Width of all staircases | : 1200mm (Minimum) |
| iii) | Clear Head room within
Plant Buildings for pipes, ducts,
Structures & cable trays etc. | : 2.5m (Minimum) |
| iv) | Clear head room in outdoor Power
Block area for cable trays & piping | : 8m (BOS) |
| v) | Clear head room in other outdoor
Areas for cable trays & piping | : 3m (BOS) |
| vi) | Clear head room for conveyors | : 8m (BOS) |
- f) All piping shall be routed at a clear height of 2500mm (min.) from the nearest access level to clear man movement.
- g) A walkway of 600mm (minimum width) with pipe hand rails & toe guards shall be provided all along length of the trestle for maintenance of cables & pipes. Ladders for approach to these platforms shall be provided near roads, passage ways and turning points.
- h) Head room for man movement shall be minimum 2.5m at ground floor in boiler area and 2.1m over all platforms.
- i) Height of trestles at approach roads to various buildings/facilities shall be 8M. In case building are located in off-site area and are adjacent to each other, then as a good engineering practice, the height of trestle shall be maintained all over as 8.0M.
- j) Each equipment room shall be provided with alternate exits in case of fire/accidents as per requirements of factory act and TAC.
- k) All cranes shall be provided with approach rung ladders at least at two places. Where ever cranes can't be maintained in situ on the carriage, facility to draw them to maintenance platforms as well as provision of suitable platforms with access facility shall be provided.
- l) Each building shall have an identified vacant space for equipment unloading and maintenance and preferably a separate bay altogether in buildings housing heavy equipment. Provision for handling equipment by monorail hoist and/or overhead crane shall be made as





specified.

- m) The plinth level with respect to the existing grade level shall be as indicated elsewhere in this specification.
- n) The minimum clear height available between two consecutive floor slabs shall not be less than five (5) meters. Adequate provision for natural ventilation and illumination shall be made as per good engineering practices.
- o) There shall be at least two (2) nos. main access doors, one on either side of each building, of which one shall be minimum 3 meters wide with rolling shutters for equipment entry. For multistoried buildings, at least two (2) nos. regular staircases diagonally opposite to each other shall be provided connecting all the floors and roof. These minimum requirements shall be augmented as required depending on the floor area, statutory requirements and TAC recommendations.
- p) All buildings shall have provision for toilet and associated effluent discharge system together with facility for drinking water. The criteria for ventilation, fire protection and illumination of building spaces specified elsewhere in this specification shall be complied with.
- q) Top cover over underground pipes/cables shall be minimum one (1) meter.
- r) Cubicle for operating personnel shall be located at safe place near the equipment.
- s) Cable racks / pipe racks shall have hand railings in walkways on both sides at appropriate heights.
- t) All the buildings and facilities will be approachable by the fire tenders.
- u) Utility pipes except fire water pipes will be routed over ground on trestles. No trenches for pipes will be envisaged as far as possible. In the Power block area, Fire water pipes will be routed in RCC trenches.
- v) Wherever steam pipes or pipes conveying hazardous fluids are running over the trestle, fire water pipes shall not be routed on the same trestle.

8.00.00 OPERATION & MAINTENANCE CONSIDERATIONS

- 8.01.00 Space for ease of operation and maintenance including equipment removal, tube bundle/cartridge/rotor pulling etc. shall be provided. All valves, gates, dampers and other devices shall be located and oriented in such a way that





**Tender Specification
for
FGD Package**

**NLC Tamil Nadu Power Ltd.
2x500 MW Project
Tuticorin, Tamil Nadu**

they are accessible from operating floor levels. Where this cannot be adhered to, platforms and walkways with hand railing and access ladders/structural steel staircase shall be provided as per layout availability to facilitate operation and maintenance.

- 8.02.00 Lifting devices i.e. hoists, chain pulleys, etc. shall be provided for handling of any equipment and/or part having weight in excess of 250 Kg during erection and maintenance activities. Suitable monorail beams, hooks etc. for this purpose shall be provided in the buildings. The monorail shall be extended to outside the buildings by minimum 2m. The monorail beam shall extend through suitable opening in the building fitted with an approved double flap steel door [with chain or better opening and closing mechanism], removable handrails, platforms etc to enable removal of equipment to ground level or vice-versa.

Lifting tackles, slings, etc. to be connected to hook of the hoist/crane shall also be provided by the Bidder for lifting the various equipment and accessories covered under this specification.

- 8.03.00 All similar parts of the equipment shall be made to gauge and shall be interchangeable with and shall be made of same material and workmanship as the corresponding parts of the equipment. Wherever feasible common components shall be employed in different pieces of equipment in order to optimize the spares inventory and utilization.

- 8.04.00 Suitable machinery-hatch, removable steel gratings / covers / hand-railing etc. shall be provided in Buildings, etc. as found necessary during detailed engineering.

9.00.00 MATERIALS

- 9.01.00 In selecting materials of construction of equipment, the Bidder shall pay particular attention to the atmospheric conditions existing at the Site and the nature of material/fluid handled. Wherever deviations are taken in respect of materials specified, the reasons shall be spelt out clearly in the proposal.

All materials shall be new and shall be of the quality most suited to the proposed application.

- 9.02.00 As far as possible, materials shall be in accordance with Indian or international standard specifications and shall be used in accordance with Indian or international codes of practice. Where such standards or codes of practice are not available sufficient information shall be provided to allow the Owner/ Consultant to assess the suitability of the material for the particular application.

Materials used for various components shall be those which have already proven operating experience in similar type of applications.

- 9.03.00 All parts which could deteriorate or corrode under the influence of the





atmospheric, meteorological or soil conditions at the Site, or under the influence of the working conditions shall be suitably and effectively protected so that such deterioration or corrosion is a minimum over the life of the plant.

9.04.00 Prohibited Materials

The use of the following materials is prohibited:

- a) High alumina cement in structural elements
- b) Wood wool slabs in permanent framework to concrete
- c) Calcium chloride in mixtures for use in concrete works
- d) Naturally occurring aggregate for use in reinforced concrete that does not comply with the applicable codes and standards
- e) Cast iron for any oil service
- f) Carcinogenic material and suspected carcinogenic materials by World Health Organization.
- g) Asbestos or any other fibrous form of hydrated magnesium silicate
- h) Any other material generally known to be deleterious if used or incorporated in such project like the facility.

10.00.00 LUBRICATION

10.01.00 Suitable efficient lubrication system shall be provided where necessary to ensure smooth operation free from undue wear.

10.02.00 Gear boxes and oil baths shall be provided with filling and drain plugs, both of adequate size. An approved means of oil indication including level switches and temperature indication shall be provided.

10.03.00 All high speed gears shall be oil bath lubricated. Low speed gears shall be lubricated by means of soft grease. Removable and accessible drip pans shall be provided to collect lubricant which may drop from operating parts.

10.04.00 All lubrication points shall be conveniently situated for maintenance purposes. It must be possible to carry out lubrication from a gangway or landing and without the removal of guarding or having to insert the hand into it. Where accessibility to a bearing for oiling purposes would be difficult a method of remote lubrication shall be fitted.

10.05.00 The Bidder shall supply grease gun equipment suitable to service each type of nipple fitted

11.00.00 LUBRICANTS, SERVO FLUIDS AND CHEMICALS





- 11.01.00 The Bidder shall provide a detailed and comprehensive specification for all lubricating oils, greases, control fluids and essential chemicals required for the entire plant. A sufficient supply of these shall be provided by the Bidder for initial commissioning, first fill and one year's topping.
- 11.02.00 The Bidder shall supply a detailed schedule giving the lubricant testing, cleaning and replacement procedures. All equipment and facilities necessary for the testing, cleaning and changing of lubricants, control fluids and chemicals shall be provided. The Bidder shall endeavour to reduce the varieties and grades of required lubricants and control fluids to a minimum, match them to those already in use in the generating station in order to simplify procurement and minimise storage requirements. All lubricants and control fluids shall be of internationally recognised standards and shall be easily obtainable from a large number of Indian suppliers. Bidder shall also indicate the equivalent Indian Standard for the above for easy procurement in future.
- 11.03.00 No lubricant or control fluid shall have toxic or other harmful effects on personnel or on the environment. Safety data sheets for all lubricants, oils, chemicals etc .specifying composition, application, chemical properties and preventive or accidental care that must be taken before and after use shall be papered by the Bidder and submitted to Owner for approval

12.00.00 PLANT LIFE AND MODE OF OPERATION

The complete FGD Plant Equipment & auxiliaries including all the equipment and systems individually and collectively shall be designed for continuous operation for an economic service life of thirty (30) years under the prevailing site conditions and for the type of duty intended.

The critical components of the FGD Plant, the life of which is limited by time and temperature dependent mechanisms such as corrosion, thermal stress, creep and low cycle fatigue, etc. are to be designed considering expected duty conditions and cyclic load variations.

The allowable stresses shall be reduced so that life expectancy to minimum 2,00,000 hours of operation can be achieved.

The plant would be designed for base load operation as well as cyclic load variation. The load variation is expected to be as per schedule depending on power demand. The FGD Plant Equipment & auxiliaries shall be suitable for shutdown on every weekend, if required. Moreover, the FGD Plant Equipment & auxiliaries should be capable to operate frequently down to 40% load.

13.00.00 PACKAGING & MARKING

All the equipment shall be suitably protected, coated, covered or boxed and crated to prevent damage or deterioration during transit, handling and storage at site till the time of erection. While packing all the materials, the limitations





**Tender Specification
for
FGD Package**

**NLC Tamil Nadu Power Ltd.
2x500 MW Project
Tuticorin, Tamil Nadu**

from the point of view of availability of railway wagon sizes in India should be taken account of. The details of various wagons normally available with Indian Railways for transportation of heavy equipment shall be considered by the Bidder. The Bidder shall be responsible for all loss or damage during transportation, handling and storage due to improper packing.

As per the information available, the dimensions of over-dimensioned (OD) consignment for transportation of the equipment by rail (if any equipment to be handled through rail transportation) are as below:

- a) Width of the Package : 3.2 Meters
(from centre-line of rails
- 1.6 metres on both sides)
- b) Height of the package from rail top : 4.47 Metres

The above indicates the dimensions which can be normally transported on the wagons without infringement of the "moving gauge". However, Bidder shall conduct his own route survey and transportation logistics for transportation of the equipments to project site by road/rail/sea and indicate the same in his proposal. In case of sea transportation, Bidder to consider unloading of equipment at Tuticorin port. Transportation to project site from the nearest railway station or sea port shall be considered by road only.

The identification marking indicating the name and address of the consignee shall be clearly marked in indelible ink on two opposite sides and top of each of the packages. In addition the Bidder shall include in the marking gross and net weight, outer dimension and cubic measurement. Each package shall be accompanied by a packing note (in weather proof paper) quoting specifically the name of the Bidder, the number and date of contract and names of the office placing the contract, nomenclature of contents and Bill of Material.

14.00.00 PROTECTION

Equipment having antifriction or sleeve bearings shall be protected by weather-tight enclosures. Coated surfaces shall be protected against impact, abrasion, discoloration and other damages. Surfaces that are damaged shall be repainted.

Electrical equipment, controls and insulations shall be protected against moisture and water damages. All external gasket surfaces and flange faces, couplings, rotating equipment shafts, bearings and like items shall be thoroughly cleaned and coated with rust preventive compound as specified above and protected with suitable wood, metal or other suitable covering to ensure their full protection. All exposed threaded parts shall be greased and protected with metallic or other suitable protectors.

All piping, tubing and conduit connections on equipment and other equipment openings shall be closed with rough usage covers or plugs. Male threaded openings shall be closed with rough usage covers or plugs. Female threaded





openings shall be closed with forged steel plugs. The closures shall be taped to seal the interior of the equipment. Open ends of piping, tubing and conduit shall be sealed and taped.

Returnable containers and special shipping devices shall be returned by the manufacturer's field representative at the Bidder's expense.

15.00.00 PAINTING

15.01.00 Please also refer to Section V of Volume-IIA, for details of painting.

15.02.00 For detail painting on building & structural steel elements refer Section-IIG/1 & IIG/2 of this specification.

16.00.00 COLOUR CO-ORDINATION & FINISH

16.01.00 Exterior surfaces throughout the FGD Plant area shall be finished in colours and textures which will blend harmoniously together and with the surrounding landscape.

16.02.00 Interior surfaces throughout the FGD area shall be finished in colours and textures which will blend harmoniously together and which will be conducive to; the comfort, well-being and high productivity of the operators. Operating equipment and services provided shall be colour coded for ease of identification.

16.03.00 All finishes shall be durable and as far as possible maintenance free. Finishes shall be easily cleaned.

16.04.00 Final colours and finishes shall be to the Approval of the Owner.

17.00.00 ENVIRONMENT PROTECTION AND NOISE LEVEL REQUIREMENT

17.01.00 Environment Protection

17.01.01 The FGD Plant Equipment & auxiliaries area shall be designed for installation and operation in harmony with the surrounding environment and all measures of pollution control shall be ensured by the Bidder to ensure zero discharge from liquid effluents and other effluents within the limits specified in Environment (Protection) Rules 1986 as amended till date.

In case 'The Ministry of Environment, Forest and Climate Change (MOEFCC)' stipulate any other conditions not specified hereunder while clearing the project, the same shall be complied by the Bidder.

17.01.02 Any specific requirement of State Pollution Authorities over and above the above stipulation shall also be complied with by the bidder.

17.02.00 Noise Level Requirement





The plant will be designed, constructed and provided with suitable acoustic measures to ensure the noise level criteria as per the following stipulations.

- a) Maximum noise level shall not exceed 85 dB (A) when measured at 1 meter away from the noise emission source, at a height of 1.5 meters above finished floor level.
- b) Maximum noise level from its source within the premises shall not exceed 70 dB (A) as per Environment (Protection) Rules 1986, Schedule-III, 'Ambient Air Quality Standards' in respect of noise.
- c) Maximum noise level shall not exceed 105 dB(A) for safety valves and associated vent pipes and 90 dB(A) for regulating drain valves. For operating control valves, the noise level shall be within the limit of 85 dBA. For all valves & orifices, the measurement shall be made one (1) metre down stream of the devices and one (1) metre from the surface of the pipe for any combination of pressure drop and flow.
- d) Any statutory changes in stipulations regarding noise limitation that may occur in future according to State Pollution Control Board or Central pollution Control Board or The Ministry of Environment, Forest and Climate Change regulation during tenure of the contract, the Bidder shall comply with the requirement.

17.03.00 Environmental design specifications

17.03.01 Construction materials and system contents prohibited

- a) No equipment or construction materials brought onto or incorporated into the Facility shall contain asbestos at any content level. Only suitable substitutes for asbestos are permitted to be used.
- b) Chemicals that are not accompanied by a material safety data sheet shall not be permitted to be used in any Work Area or incorporated into the Work.
- c) No ozone depleting substances (as defined by the 1987 Montreal Protocol) at any level are allowed to be used in systems provided by Bidder. Only suitable substitutes are permitted.

17.03.02 Ambient noise mitigation

The Facility noise levels shall not exceed the more stringent of Applicable Law or the Noise Compliance Guarantee.

The Bidder shall abate ambient noise to public receptors in accordance with the more stringent of Applicable Law or the Noise Compliance Guarantee. Mitigation measures that shall be considered during project design include, but are not limited to, the following:





- a) Selecting equipment with lower sound power levels;
- b) Installing silencers for fans, blowers, compressors;
- c) Installing suitable mufflers on engine exhausts and compressor components;
- d) Installing acoustic enclosures for equipment causing radiating noise;
- e) Applying sound insulation to improve the acoustic performance of buildings;

18.00.00 INSPECTION AND TESTING

18.01.00 Inspection and Tests during Manufacture

18.01.01 The method and techniques to be used by the Bidder for the control of quality during manufacture of all FGD Plant Equipment & auxiliaries shall be as stipulated elsewhere in the specification.

18.01.02 The Owner's general requirements with respect to quality control and the required shop tests are set out elsewhere in this specification.

18.01.03 Before any item of FGD Plant Equipment & auxiliaries leaves its place of manufacture. the Owner shall be given the option of witnessing inspections and tests for compliance with the specification and related standards.

18.01.04 Advance notice shall be given to the Owner as agreed in the Contract, prior to the stage of manufacture being reached, and the piece of plant must be held at this stage until the Owner has inspected the piece, or has advised in writing that inspection is waived. If having consulted the Owner and given reasonable notice in writing of the date on which the piece of plant will be available for inspection, the Owner does not attend the Bidder may proceed with manufacture having forwarded to the Owner duly certified copies of his own inspection and test results.

18.01.05 Under no circumstances any repair or welding of castings be carried out without the consent of the Owner. Proof of the effectiveness of each repair by radiographic and/or other non-destructive testing technique, shall be provided to the Owner.

18.01.06 All the individual and assembled rotating parts shall be statically and dynamically balanced in the works.

Where accurate alignment is necessary for component parts of machinery normally assembled on site, the Bidder shall allow for trial assembly prior to despatch from place of manufacture.

18.01.07 All materials used for the manufacture of equipment covered under this





**Tender Specification
for
FGD Package**

**NLC Tamil Nadu Power Ltd.
2x500 MW Project
Tuticorin, Tamil Nadu**

specification shall be of tested quality. Relevant test certificates shall be made available to the Owner. The certificates shall include tests for mechanical properties and chemical analysis of representative material.

- 18.01.08 All pressure parts shall be subjected to hydraulic testing as per the requirements of IBR. Other parts shall be tested for one and half times the maximum operating pressure, for a period not less than thirty (30) minutes.
- 18.01.09 All necessary non-destructive examinations shall be performed to meet the code requirements of ASME or IBR as applicable.
- 18.01.10 All welding procedures adopted for performing welding work shall be qualified in accordance with the requirements of Section-IX of ASME code or IBR as applicable. All welded joints for pressure parts shall be tested by liquid penetrant examination according to the method outlined in ASME Boiler and Pressure Vessel code. Radiography, magnetic particle examination and ultrasonic testing shall be employed wherever necessary/ recommended by the applicable code. At least 10% of all major butt welding joints shall be radiographed. Statutory payments in respect of IBR approvals including inspection shall be made by Bidder. Bidder's scope and responsibility shall also include preparation and submission of all necessary documents in the specific formats and manner stipulated by the statutory bodies, coordination and follow up for above approvals.
- 18.02.00 Inspection and Testing at Site
- 18.02.01 The full requirements for testing the system shall be agreed between the Owner and the Bidder prior to Award of Contract. The completely erected System shall be tested under the supervision of the Technical Advisor of the Bidder on site under normal operating conditions. The Bidder shall also ensure the correct performance of the System under abnormal conditions, i.e. the correct working of the various emergency and safety devices, interlocks, etc.
- 18.02.02 The Bidder shall provide complete details of his standard procedure for testing the quality of erection and the performance of erected FGD Plant Equipment & auxiliaries. These tests shall include site pressure test on all erected pipe work to demonstrate the quality of the pipe work and the adequacy of joints made at site.
- 18.03.00 For details of specific tests required on individual equipment refer to respective Technical volumes of this specification.

19.00.00 TRAINING OF OWNER'S PERSONNEL

The Bidder shall extend all possible assistance and co-operation to the Owner regarding the transfer of technology and developing expertise in the area of operation and maintenance of the FGD Plant Equipment & auxiliaries.





**Tender Specification
for
FGD Package**

**NLC Tamil Nadu Power Ltd.
2x500 MW Project
Tuticorin, Tamil Nadu**

The details of the training programme will be discussed and finalised with the successful Bidder.

- 19.01.00 Training at Bidder's Premises
- 19.01.01 The Bidder shall conduct training of engineers and plant operators of the Owner on engineering, operation and maintenance of the Plant at the Bidder's or Associates or Sub-Bidder's premises where adequate training facilities are available during the design and manufacturing stage.
- 19.01.02 The training may also be arranged by the Bidder in any Plant where the equipment manufactured by the Bidder or his Associates is under installation, operation or testing to enable the trainees to become familiar with the equipment being furnished by the Bidder. All expenses inherently related to the training shall be borne by the Bidder and shall include but not be limited to travel expenses (international and inland fares), lodging and per diem charges as well as medical insurance, instructors fee, programme and miscellaneous cost to be incurred during the training.
- 19.01.03 The training programme shall be adequate for the trainees to acquire the necessary expertise and competence in the operation and maintenance of the FGD Plant Equipment & auxiliaries. The Bidder shall be responsible for the development of the Training Module and Programme Schedule which shall be submitted to the Owner for approval.
- 19.01.04 The components of the training modules shall include but not be limited to the training procedures/methodology, instructional materials such as audio visual materials, CDs and slides and manuals for each trainee. Three (3) sets of the materials included in the training modules shall be handed over to the Owner upon completion of the training. An evaluation shall be jointly undertaken by the Bidder and the Purchaser's representative on the adequacy, appropriateness and relevance of the training and the programme effectiveness after the training. The training material shall be in English language only.
- 19.01.05 The content of the training programme shall include but not be limited to:
1. Limestone based Flue Gas Desulphurisation Plant for Coal fired thermal plant principles in management and practice for operators, technicians and maintenance personnel.
 2. Plant operation and systems training for operators including simulator training as applicable.
 3. Maintenance training programme covering electrical, mechanical and instrumentation and control.
- 19.01.06 The timing of the training should be such that the participants will be conversant with sufficient know-how to participate in the pre-commissioning and commissioning tests of the FGD Plant Equipment & auxiliaries. Said training programme shall be submitted to the Owner for approval.





**Tender Specification
for
FGD Package**

**NLC Tamil Nadu Power Ltd.
2x500 MW Project
Tuticorin, Tamil Nadu**

The Bidder shall provide qualified English speaking instructors and training coordinator(s) during the tenure of the training programme.

- 19.02.00 Operation and Maintenance Training at Site
- 19.02.01 The Bidder shall provide a comprehensive training programme related to design application, plant management, operation and maintenance, including trouble shooting, of the Bidder's supplied system and equipment at the Site starting from Start of Commissioning and thereafter up to the Final Acceptance of the first FGD Unit.
- 19.02.02 The following instructors shall be at the Site continuously during the training:
- a) One (1) for Flue Gas Desulphurisation Plant
 - b) One (1) for Limestone Handling system (part time)
 - b) One (1) for Electrical Works
 - c) One (1) for Instrumentation and Control
- 19.03.00 The total man-months for training of engineers shall be maximum thirty (30), having following indicative break-up:

Discipline	No. of Man-months
Operation	12
Mechanical Maintenance	4
Electrical Maintenance	4
Control & Instrumentation	6
Maintenance Planning	4

	30

However, the details of the training programme will be discussed and finalised with the successful Bidder.

- 19.03.01 On-the-Job Training
- 19.03.02 During the period of pre-commissioning, commissioning and trial operation, the Owner shall provide operation and maintenance personnel to assist the Bidder in the operation and maintenance of his supply and work under the direction of the Bidder for the purpose of on-the-job training.
- 19.03.03 The Owner shall have the right to send to the Site his employees later intended to operate and maintain the equipment supplied under this Contract. The Bidder shall, without additional cost, use his site staff to instruct these employees on the operation and maintenance of the equipment. All instructions shall be in the English language.





ANNEXURE-I

LIST OF STANDARDS FOR REFERENCE

- a) International Organisation for Standardisation (ISO).
- b) International Electro-technical Commission (IEC).
- c) American Society of Mechanical Engineers (ASME).
- d) American National Standards Institute (ANSI).
- e) American Society for Testing and Materials (ASTM).
- f) American Institute of Steel Construction (AISC).
- g) American Welding Society (AWS).
- h) Architecture Institute of Japan (AIJ).
- i) National Fire Protection Association (NFPA).
- j) National Electrical Manufacturer's Association (NEMA).
- k) Japanese Electro-technical Committee (JEC).
- l) Institute of Electrical and Electronics Engineers (IEEE).
- m) Federal Occupational Safety and Health Regulations (OSHA).
- n) Instrument Society of America (ISA).
- o) National Electric Code (NEC).
- p) Heat Exchanger Institute (HEI).
- q) Tubular Exchanger Manufacturer's Association (TEMA).
- r) Hydraulic Institute (HIS).
- s) International Electro-Technical Commission Publications.
- t) Performance Test Codes (PTC).
- u) Applicable German Standards (DIN).
- v) Applicable British Standards (BS).
- w) Applicable Japanese Standards (JIS).





Tender Specification
for
FGD Package

NLC Tamil Nadu Power Ltd.
2x500 MW Project
Tuticorin, Tamil Nadu

ANNEXURE-I

- x) Electric Power Research Institute (EPRI).
- y) Standards of Manufacturer's Standardization Society (MSS).
- z) Bureau of Indian Standards Institution (BIS).
- aa) Indian Electricity Rules.
- bb) Indian Boiler Regulations (IBR).
- cc) Indian Explosives Act.
- dd) Indian Factories Act.
- ee) Tariff Advisory Committee (TAC) rules.
- ff) Pollution Control regulations of Ministry of Environment, Forest and Climate Change, Govt. of India .
- gg) Central Board of Irrigation and Power (CBIP) Publications.
- hh) National Building Code (NBC).
- ii) Indian Road Congress (IRC).





ANNEXURE-II

CRITERIA FOR LAYOUT

PLOT PLAN LAYOUT REQUIREMENTS

The guidelines will be applied in general, unless otherwise stated in other technical Volumes. In addition to these guidelines, Bidder shall refer the attached Area Plans, drawing no. 17A14-DWG-M-0002A, 0002B and 0002C for tentative arrangement of the various facilities under this package.

ITEM	SPECIFICATION REQUIREMENT
A. Site conditions to be considered	
1. Prevalent wind direction(s) during dry seasons (for deciding the location of limestone stock pile and unloading areas, minimising the pollution effect due to dust)	West to East. Also see wind-rose in plot plan.
2. Location of:	
a) Plant drainage outfall point(s).	Towards North East
b) Railway entries & exits.	Not Applicable
B. Layout Requirements	
1. Maximum permissible slope in	
a) Rail track	Not applicable
b) Road	1 in 30
c) Sides of unpaved embankment	1 in 2
2. Required road width	
a) Main Plant access road	10.0 Metres with 1.5 m wide shoulders on either side.
b) Primary roads without access for 500 T crane	7.5 Metres with 1.5 m wide shoulders on either side
c) Access ways	4.0 Metres with 1.2m shoulders on either side.





ANNEXURE-II

d)	Road to the absorber area :	Yes.
3.	Required minimum horizontal distance between the nearest points of	
a)	Plant boundary and the boundary of residential area	(Local municipality/factory rule)
b)	Electrical transformer and any other	As per the Tariff Advisory building/facility Committee Rules.
c)	Fire water supply installation and any building/facility subject to fire risk.	As per the Tariff Advisory Committee Rules.
d)	Inflammable liquid (fuel oil, etc.) storage & handling installation and their fencing and other buildings/facilities.	Rules of the Indian Explosive (Indian Explosives Act) and Indian Petroleum Code.
4.	Required minimum vertical clearance	
a)	Under pipes/cable racks at road crossings	8.0 Metres.
b)	Soil coverage over underground pipes for CW/ACW piping	1.0 Metre (minimum) 1.5M
c)	Outdoor Pipe/Cable trench (if required)	150 mm above FGL
d)	Minimum height of equipment (switchgear, cabinet etc.) above floor for HT cable entry	500 mm
e)	Minimum height of equipment (switchgear, cabinet etc.) above floor for LT cable entry	300 mm
5.	Railway Wagon clearance	Not applicable
6.	Minimum Clearance between any road edge and building/structure/ any fixed installation.	3 Metres.

ITEM

SPECIFICATION REQUIREMENT





Tender Specification
for
FGD Package

NLC Tamil Nadu Power Ltd.
2x500 MW Project
Tuticorin, Tamil Nadu

ANNEXURE-II

7. Required level, above the local developed grade level, of
- a) top of all roads 150 mm.
 - b) all outdoor paved areas 150 mm.
 - c) Temporary storage areas, workshops, offices, residence etc. required at the time of erection work. Yes.





ANNEXURE-II

BUILDING/ EQUIPMENT LAYOUT REQUIREMENTS

1.0 BROAD GUIDELINES FOR LAYOUT PLAN

General layout plan indicating the available spaces for the exiting project is as shown in the tender drawing placed in Volume-J of the tender specification. It shall form the basis for further elaboration by the Bidder for the plant facilities, which are in his scope.

While preparing the detailed layout, planning the facilities in the Bidder's scope and deciding upon the transportation and construction/ erection strategy and functional requirements, the Bidder shall ensure the following aspects in addition to those mentioned earlier in this section:

- i) The entire construction activity shall take into account the commissioning of the units.
- ii) The finished floor level at ground level of the TG building shall be designated at EL. 0.0M and shall be 500mm above the finished ground level (FGL) of that area.

The finished floor level for various areas / facilities shall be as follows:-

FFL of Main Plant Building -El.(±) 0.00M

Top of paving for Transformer Yard -El. (-) 0.10M

Top of paving for Boiler/ ESP/ FGD/
Chimney area -El. (-) 0.20M

FFL of buildings 500 mm above FGL of
respective area

- iii) Hazardous chemical storage complex shall be designed in accordance with statutory agencies guideline
- iv) DG Set Exhaust Pipes (Height & Orientation) shall be designed as per Environmental Regulations.

1.1 Common Control Room

Common Control room shall be provided by the Bidder common for both units.

Common Control Rooms / Control Equipment Rooms for each unit/ RIO rooms for each unit shall be provided with air-conditioning by the Bidder.





ANNEXURE-II

2.0 PLANT LAYOUT REQUIREMENT

2.1 The location of main plant block is indicated in the Plot plan drawing enclosed in Volume-J of the tender specification, however Bidder has to develop layout keeping the location/orientation of the existing main power block same as indicated in bid document. Bidder shall develop his own layout for the equipment offered and the same to be clearly brought out in the bid under the scope of Bidder. However, while developing the layout the Bidder must give due considerations for the following requirements:

- i. The FGD control, control equipment's room and the Electrical room shall be common for both units and be located near the Absorber tower.
- ii. The Electrical and control room shall be single-level and shall essentially house but not be limited to the followings:
 1. Electrical Panels
 2. Control panels, operator's consoles etc. for all modules. The control room shall not have any internal column inside the room. Large span roof beams for control room to be adopted and designed.
 3. Computer room with engineering work stations & associated workstations.
 4. A small conference room.
 5. FGD Plant In charge room.
 6. UPS & batteries.
 7. Cabling and all other facilities associated with the above system.

2.2 The Control Room and control equipment rooms, computer room with programmer station, UPS room, shall be provided with Air conditioning. Washroom/Toilet facilities for ladies & gents separately shall be provided. Further, no vertical bracings, pipes, cable shafts etc. shall be routed through control room or control equipment room area. Design of control room interior including lighting, roof, flooring and decoration will also be provided by the Bidder

2.3 The following clearances to be maintained for C&I DCS/ DDCMIS/ PLC cabinets:

i)	Clearance from back	1200mm
ii)	Clearance from front wall	1200mm
iii)	Clearance from side	1000mm

The above clearances are minimum requirement and may increase with increase in door swing of the cabinets.

2.4 Layout of facilities and equipment shall allow removal of transformers without disturbing equipment, piping, cabling, ducts routed in the area.





ANNEXURE-II

Adequate space and provision for handling/removal of booster fans, pumps, motors, heaters, heat-exchanger, compressors, Switchgear Panels, Transformers during maintenance shall be provided.

- 2.5 The Limestone slurry preparation building, Gypsum dewatering building, Gypsum storage building shall be of multi-storied type designed to utilize gravity flow wherever possible.
- 2.6 Equipment requiring monitoring during regular operation shall be approachable from the ground floor through staircase. Staircase with minimum width of 1200 mm shall be provided for approach to elevated structures at 5m height from the nearest platform. Below this height a vertical ladder with minimum clear width of 600 mm may also be acceptable.
- 2.7 Platform with a minimum clear width of 1000 mm shall be provided all around the lowest absorber spray levels and mist eliminators. Similar platforms shall be provided at subsequent elevations if they are more than 3000 mm apart from each other. An adequately sized manhole with platform (min. 2 sq. m) shall be provided above each spray level. Ladders/staircase shall be provided for the access to the platform.
- 2.8 The absorber slurry recirculation pumps, gypsum bleed pumps and limestone feed pumps shall be mounted on the ground level. Suitable approach and platforms shall be provided for all the valves required during regular operation.
- 2.9 A 1500 mm space shall be provided around all pumps, except absorber recirculation pumps, where a 2000 mm space shall be provided.
- 2.10 Platform with a minimum width of 1500 mm shall be provided all around the pulverizers and feeders. Approach along with suitable platforms shall be provided for ball loading hoppers.
- 2.11 A 1000 mm wide platform with suitable approach shall be provided around each hydro-cyclone.
- 2.12 A 2000 mm wide floor/platform shall be provided all around each belt filter.
- 2.13 Independent floor drains with separate down comers shall be provided where fire protection system are provided.
- 2.14 All heavy equipment located in the buildings shall be accessible by the EOT cranes or hoists for their handling during erection and maintenance. Wherever special handling procedures are to be followed, the same shall be described in and attached with the bid.





**Tender Specification
for
FGD Package**

**NLC Tamil Nadu Power Ltd.
2x500 MW Project
Tuticorin, Tamil Nadu**

ANNEXURE-II

- 2.15 Monorail for Magnetic Separators (ILMS & SEM) shall extend outside the building by minimum 2.0m. Tramp iron chute (up to ground level) shall be provided at floor on which above magnetic separators are installed.
- 2.16 The safety guard for the Take-up Carriage / Counterweight box of the Gravity Take-up unit shall be provided with a removable panel for entry of operating personnel for greasing / maintenance of pulleys etc.
- 2.17 Each Floor cleaning chute of Limestone Handling Plant buildings shall terminate at about 1.2 m above ground level. Floor cleaning chute (debris chute) shall be connected to tramp metal chute wherever feasible.
- 2.18 A suitable rail track and associated facilities like, mooring posts etc., shall be provided to facilitate the movement of transformers to the access road/ maintenance area.
- 2.19 Adequate distance shall be maintained between the transformers. As basic guidelines following norms will be adhered to:

- i) Auxiliary transformers shall be separated from the adjacent building/structures and from each other by a minimum distance as defined below or by a fire wall of two hours of fire resisting of height at least 600 mm above bushing / pressure relief vent whichever is higher.

Oil capacity of individual transformer separating distance (in liters)	Clear (in Meters)
5,000 to 10,000	8.0
Above 10,000 to 20,000	10.0
Above 20,000 to 30,000	12.5
Over 30,000 or more	15.0

- ii) In case of auxiliary transformers having an aggregate oil capacity in excess of 2300 liters or more but individual oil capacity of less than 5000 liters, the separating distance between transformers and surrounding building shall be at least 6M unless they are separated by fire separating walls or are protected by high velocity spray system.
- iii) Waste water & oily waste from 220KV / 11 KV Transformer and auxiliary transformer yard areas shall be collected in common oil pits. These common oil pits shall be connected to ETP. Two nos. (1W+1S) vertical screw pumps shall be installed in each common oil pit. These pumps shall transfer oily waste to common oily pit located in ETP area for further treatment through suitable piping system.
- iv) HVWS protection shall be provided as per CEA guidelines if the oil capacity more than 2000 liters or capacity of transformer 10MVA or more.





ANNEXURE-II

3.0 Layout requirements for Electrical MCC/switchgear rooms

For finalizing room size, following points shall be considered: –

- i) Minimum clearance between HV/MV switchgear and LV switchgear shall be maintained as 2500mm.
- ii) Minimum clearance between any obstruction like column, wall and vertical raceway, etc. and rear of LV switchboard shall be maintained as 1000mm respectively.
- iii) Minimum clearance between two LV switchgear facing each other shall be maintained as 2000mm.
- iv) Minimum rear to rear clearance of LV switchgear shall be maintained as 1000mm respectively.
- v) Minimum rear to front clearance for PCC to PCC shall be maintained as 2000mm.
- vi) Clearance between the bottom of ventilation duct and top of electrical panel shall be as per statutory requirement
- vii) Minimum clearance between two non-drawout panels facing each other shall be maintained as 1500mm.
- viii) Minimum clearance between wall and end of switchgear shall be maintained as 1000mm.
- ix) Minimum clearance between the sides of two switchgears shall be 1000mm.
- x) Minimum clearance between LV switchgear to dry type transformer shall be kept as 2000mm.
- xi) Access to rooms, doors, etc. to be provided in various floors shall consider movement of the panels during erection and later during maintenance.
- xii) Switchgear room/MCC room and cable vault shall be pressurized above the atmospheric pressure to prevent ingress of dust.
- xiii) Control room, switchgear room shall be provided with separate entry and exit door. Rating of fire proof door to be provided in cable vault shall be 2 hours.
- xiv) Walkways shall be provided for accessing the cable laid on cable trays in all pipe racks & cable racks.
- xv) Cable vault floors shall have all openings properly ridged to prevent water drainage into the room below. In addition proper facilities shall be provided at cable vault floor to drain the water in case of operation of sprinkler system.
- xvi) Air-conditioned rooms shall be provided with double door.
- xvii) During design stage adequate space shall be provided for expansion of board on either side to accommodate addition of panel to take care of unforeseen factors.
- xviii) All busducts shall enter the 415V PMCC from top.
- xix) Minimum clearance between two HV / MV switchgear facing each other shall be maintained as 3500mm.





ANNEXURE-II

- xx) Bottom to roof beam in HT/ LT switchgear room from finished floor level shall be 4.5m when the room has busducts and shall be 4.0m without busduct.
- xxi) Cable spreader floors shall have all openings properly ridged to prevent water drainage into the room below. In addition proper facilities shall be provided at cable spreader floor to drain the water in case of operation of sprinkler system.
- xxii) Wherever cables are taken out through wall openings, such openings shall be properly sealed with fire sealing compound.
- xxiii) Fire isolation wall shall be provided wherever necessary as per fire safety norms. Opening in the fire separation wall shall be properly sealed with fire sealing compound after laying of cables.
- xxiv) Major routes in BOP area (BOP Package area) shall be on overhead cable trays either supported from available structures, building structure. Only in specific areas as shall be approved by purchaser/consultant where number of cables are too small compared to the route length and in transformer yard, cable shall be routed in cable trenches.
- xxv) The minimum clear height (excluding roof beam) shall be 3.0m.
- xxvi) Bottom of roof beam shall be min. 3m
- xxvii) In cable vaults clear height in walkway or cross over below the cable trays shall be 2.1m

4.0 EQUIPMENT LAYOUT REQUIREMENT

- 4.1 Local Pits/trenches in buildings are to be avoided. However pits/sumps which are unavoidable shall be provided with required dewatering arrangements by means of permanently fixed drainage pumps, further treatment of effluent for reuse purposes and piping up to the ETP for FGD Pump. Bidder shall provide required sump pumps/drainage pumps/submersible pumps, effluent treatment equipment/ system & Piping etc.
- 4.2 Pump shall be permanently fixed in the pits/sumps. If the pit depth is shallow, vertical top mounted sump pumps shall be provided and in deep pits self-priming drainage pumps (horizontal type) at floor level or alternatively submersible type pumps may be provided.
- 4.3 Each pit/sump shall be provided with two numbers (2x100% Capacity) of respective type pumps so that the entire pit is evacuated within 15-20 minutes and the operation of the pumps shall be interlocked through level measurement devices to be installed in the pit/sump so that the pumps shall start automatically and empty the pit.
- 4.4 The general design and construction features of Vertical sump pumps and Submersible pumps are furnished elsewhere.
- 4.5 In addition to the above, suitable drainage arrangement of different floors of plant buildings shall be provided. These drains shall be led to sumps in ground floor as per approved layout. Bidder shall also provide sump pumps of 2x100%





ANNEXURE-II

- capacity in each sump pit and the sump drainage water shall be led to the ETP for FGD plant. Bidder shall also provide piping's, fittings etc. for taking this drain/oily waste water to ETP.
- 4.6 Bidder to furnish the detailed erection strategy along with the bid for major equipment's located in FGD area.
- 4.7 Bidder's shall prepare the detailed layout of FGD plant in the available space in the existing main power block area indicating the location of all major equipment. The layout shall be furnished along with the bids submitted by the Bidder.
- 4.8 Valves in the Bidder's scope shall be located in accessible positions
- 4.9 Provision of monorails with chain pulley blocks/HOT cranes along with hoist, as required shall be kept.
- 4.10 Approach for removal of equipment for maintenance shall be provided.
- 4.11 A/C and ventilation ducts, Bus ducts, and Critical Piping routes to be identified at conceptual stage.
- 4.12 No cable trenches, under-ground cable vaults and pipe trenches are acceptable unless otherwise approved by the Purchaser.
- 4.13 All the pipes and cables within the Plant boundary shall be routed above ground.
- 4.14 All other safety requirements as per the factories act, shall be observed while developing the layout.
- 4.15 Battery rooms should be properly ventilated to release the gases produced. An easily accessible wash basin should be provided in the battery room.
- 4.16 Pipelines shall be routed in such a way to avoid interference with other pipes and their hangers and supports, structure, equipment, electrical conduits, cable trays, ventilation ducts etc. The pipe routing shall also take into account the availability of structural members for providing suitable supports and hangers. Hot and cold premises of the system shall be suitably isolated/ segregated from each other. Also the electrical premises shall be fully segregated from system piping.
- 4.17 Piping layout shall have adequate flexibility to absorb all thermal expansion without causing undue stress in the pipelines.
- 4.18 All piping shall be grouped where practicable and shall be routed to present a neat appearance.
- 4.19 The piping shall be arranged to provide clearance for removal of equipment





ANNEXURE-II

requiring maintenance and for easy access to valves and other piping accessories required for operation and maintenance. Availability of access to valves and specialties shall be properly indicated on the layout drawing.



714945/2022/PS-PEM-MAX



Tender Specification
for
FGD Package

NLC Tamil Nadu Power Ltd.
2x500 MW Project
Tuticorin, Tamil Nadu

VOLUME : II-A
SECTION - VI
ENGINEERING SERVICES



Development Consultants Pvt. Ltd.

Vol. II-A/Section-VI
Engineering Services



CONTENTS

CLAUSE NO.	DESCRIPTION	PAGE NO.
1.00.00	GENERAL	1
2.00.00	DESIGN COORDINATION MEETING	1
3.00.00	CO-OPERATION WITH OTHER SUCCESSFUL BIDDERS AND CONSULTANTS	1
4.00.00	GUIDELINES FOR OWNER'S ENGINEERING SERVICES	2
5.00.00	INSTRUCTION MANUALS	4
6.00.00	PLANT HANDBOOK FOR FGD PLANT EQUIPMENT & AUXILIARIES	5
7.00.00	TENDER STAGE DOCUMENT SUBMISSION	5
8.00.00	CONTRACT STAGE DOCUMENT SUBMISSION AND APPROVAL PROCEDURE	6
ANNEXURE-1	FINALISATION OF SUBVENDOR	9





VOLUME : II-A

SECTION-VI

ENGINEERING SERVICES

1.00.00 GENERAL

1.01.00 As part of the overall project management activity, the Successful Bidder shall be responsible for proper Owner's Engineering and co-ordination of activities during various phases of execution of the contract. The Successful Bidder shall identify a person, designated as Project Manager, with whom the Owner, the Consulting Owner's Engineer or the Review Consultant shall interact on matters related to Owner's Engineering as well as execution of the contract. The Project Manager shall be the single-point contact person on behalf of the Successful Bidder and shall be responsible for all Owner's Engineering co-ordination. The Owner /Consultant /Review Consultant shall interact with the Project Manager only on all matters of co-ordination between the Owner and the Successful Bidder or on matters involving the Successful Bidder, his manufacturing units and sub-vendors. For the purpose of expediting the Owner or his representative may sometimes interact with the manufacturing units or sub-vendors of the Successful Bidders. However such interaction will not, under any circumstance, dilute the responsibility of the Successful Bidder to provide a fully Owner's Engineered and coordinated package under this contract.

1.02.00 On finalization of the contract, a procedure for exchange of Owner's Engineering information will be mutually agreed and finalized between the Owner and the Successful Bidder.

2.00.00 DESIGN COORDINATION MEETING

The Successful Bidder and his sub-vendors will be called upon to attend design co-ordination meetings with the Owner's Engineer, other Successful Bidders and the Consultants of the Owner during the period of execution of contract. The Successful Bidder including his sub-vendors shall attend such meetings at their own cost at Owner's office in Neyveli or Consultant's office in Kolkata/ or at mutually agreed venue as and when required and fully cooperate with such persons and agencies involved during those discussions.

3.00.00 CO-OPERATION WITH OTHER BIDDERS AND CONSULTING OWNER'S ENGINEERS

The Successful Bidder shall agree to cooperate with the Owner's other Bidders and Consulting Owner's Engineers and freely exchange with them such technical information as is necessary to obtain the most efficient and economical design and to avoid unnecessary duplication of efforts. The Owner's Engineer shall be provided with copies of all correspondences addressed by the Successful Bidder to other Sub- Vendors and Consulting





Owner's Engineers in respect of such exchange of technical information.

4.00.00 GUIDELINES FOR OWNER'S ENGINEERING SERVICES

- 4.01.00 Prior to commencement of the Owner's Engineering work as part of design submissions, all aspects of design viz., criteria for selection and sizing of all equipment and systems, design margins etc. including that for structural steel and civil work shall be outlined and these shall form the basis for the detailed Owner's Engineering work.
- 4.02.00 Owner's Engineering work shall be performed on modern and proven concepts and internationally accepted good Owner's Engineering practices but fully compatible with the Indian environments. Owner shall have the right to review and approve the Owner's Engineering work by themselves and/or through consultant and ask for any clarifications and changes/modifications to the work performed by Successful Bidder.
- 4.03.00 At any stage during the performance of assignment, the Successful Bidder may be required to make certain changes/modification/improvements in design/drawing/other documents, which in the opinion of the Owner could result in better improved design, layout, operability, plant availability, maintainability, reliability or economy of the FGD Plant Equipment & auxiliaries and its systems/sub-systems in view of revised and more accurate information/data available at a later date(s) or feedback(s) received during execution/operation of similar units. Such changes/ modifications/improvements required could be identified by Owner and/or consultant and mutually discussed. Owner requires the Bidder to incorporate such action in the subject assignment appropriately without any additional cost liability and time implication to the Owner and same shall be within the responsibilities and Scope of the Successful Bidder.
- 4.04.00 During the course of review of detailed Owner's Engineering stages, it may be essential in the opinion of Owner to obtain certain classified data for review purposes only. In case Owner so desires, the Bidder shall submit such data to Owner.
- 4.05.00 During the course of review of detailed Owner's Engineering, it may be essential in Owner's opinion to obtain data and information on similar equipment and plants Owner's Engineered by the Bidder. In case Owner so desires the Bidder shall submit such data and information to the Owner.
- 4.06.00 It is not the intent to give details of every single task covered in the total Owner's Engineering work to be carried out by Successful Bidder, however, all Owner's Engineering work required for the satisfactory completion of the FGD Plant Equipment & auxiliaries as specified shall be carried out by the Successful Bidder. Broadly, the following are the minimum requirements in respect of scope of major items of work:
- 4.06.01 Preparation, updating and finalisation of scheme drawings, control and interlock diagrams, detailed and fully dimensioned layout drawings (FGD Plant area layout and equipment layout detailed plan, elevation and cross-sectional drawings at different elevations/ floor levels) covering all mechanical, electrical,





**Tender Specification
for
FGD Package**

**NLC Tamil Nadu Power Ltd.
2x500 MW Project
Tuticorin, Tamil Nadu**

C&I, civil and structural items, equipment, systems and facilities.

Drawings and Schedules prepared by the Successful Bidder from time to time, as detailed designs are developed, shall be submitted for Owner's/ Consultant's approval before the work is taken up. Revisions, corrections, additions to drawings and schedules shall not be considered to change the scope of work.

- 4.06.02 Preparation of detailed technical specifications including data sheets, tender drawings and bill of material for all bought out items, as also finalisation of corresponding sub-Vendors.
- 4.06.03 Review of sub-Vendor's data, drawings, design calculations, schedules, bill of materials, instruction manuals etc. for all equipment, before forwarding them to Owner/Consultant for approval.
- 4.06.04 Preparation of civil construction drawings for all equipment showing foundation details and full details regarding equipment loads, floor openings, details of embedments, etc. required for preparation of civil construction drawings and also as referred at relevant sections of Scope & Exclusions. These documents shall be preceded by appropriate design calculations, static and dynamic analysis as necessary.
- 4.06.05 Preparation and finalisation of process piping and instrumentation diagrams and schematics, complete in all respects for all systems/packages of the FGD Plant package.
- 4.06.06 Preparation of consolidated schedules and bills of materials, including line numbers, tag numbers, source of supply, service conditions, specifications, materials, types and connections details, quantities for items of the FGD Plant package including dampers, steam traps, strainers, instrumentations, ducting.
- 4.06.07 Sizing of all piping and equipment as per the stipulated design criteria; carrying out of flexibility analysis/dynamic analysis as necessary; hangers & support Owner's Engineering.
- 4.06.08 Final revision of all documents including preparation and compilation of Instruction Manuals for installation, commissioning, operation and maintenance for all equipment and systems. Refer clause 5.00.00 for the specific requirement in this regard.
- 4.06.09 Certification and submission of final as-built drawings for all areas.
- 4.06.10 Preparation and compilation of all drawings, schedules and instructions which may be required at site, whether separately mentioned or not.
- 4.06.11 All erection and assembly drawings which may be required at site.
- 5.00.00 **INSTRUCTION MANUALS**
- 5.01.00 The Bidder shall provide all necessary instruction manuals for the Owner's





review, comment, and final acceptance as required in the contract. The instruction manual shall contain full details required for erection, commissioning, operation and maintenance of each equipment. The instruction manual shall be submitted in the form of one (1) soft copy in CD and 15 hard copies.

5.02.00 **Erection Manuals**

5.02.01 The erection manuals shall be submitted at least three (3) months prior to commencement of erection activities of particular equipment/system. The manuals shall contain the following as a minimum:

- a) Erection strategy.
- b) Sequence of erection.
- c) List of tools, tackles, heavy equipments like cranes, dozers etc required for erection.
- d) Bill of Materials.
- e) Safety precautions to be followed during erection.
- f) Erection instructions.
- g) Critical checks and permissible deviation/tolerances.
- h) Check-list for pre-commissioning activities
- i) Check-list for commissioning of the system.
- j) Procedure for initial checking, testing and acceptance norms.

5.03.00 **Operation & Maintenance Manuals**

5.03.01 The operating and maintenance instructions together with drawings of the equipment, as completed, shall be in sufficient detail to enable the Owner to operate, maintain, dismantle, reassemble, and adjust all parts of the equipment. They shall outline a step-by-step procedure for all operations likely to be carried out during the life of the FGD Plant Equipment & auxiliaries. Each manual shall include a complete set of drawings together with performance/ rating curves of the equipment and test certificates wherever applicable.

5.03.02 If after commissioning and initial operation of the FGD Plant Equipment & auxiliaries, the manuals require any modification/ additions in the view of the Owner or Bidder, the same shall be incorporated and the updated final manuals shall be submitted to the Owner.

5.03.03 The manuals shall include the following:

- a) List of spare parts along with their drawing and catalogue and Pro-





forma for ordering spares.

- b) Location and identification guide for bearings of various equipments and lubrication schedule including charts showing lubrication checking, testing and replacement procedure.
- c) Wherever applicable, fault location charts shall be included to facilitate fault detection.
- d) Detailed specification for all consumables (including lubricating oils, greases, chemicals etc.) required for each equipment.

6.00.00 PLANT HANDBOOK FOR FGD PLANT EQUIPMENT & AUXILIARIES

The Bidder shall provide the plant handbook for FGD Plant Equipment & auxiliaries to the Owner as per provision of the contract.

The Plant Handbook shall contain the following as a minimum:

- a) Design and performance data
- b) Process & instrumentation diagrams
- c) Single line diagrams
- d) Sequence & Protection interlock schemes
- e) Alarm and trip values
- f) Performance curves
- g) General layout plan and layout of TG building and auxiliary buildings
- h) Important Do's and Don'ts.

7.00.00 TENDER STAGE DOCUMENT SUBMISSION

7.01.00 The Bidder shall submit along with his bid all documents/drawings as specified in specification and respective sections of the Technical Specifications in Vol-II and Vol-III. The documents shall include but not be limited to the following:

- a) All Bid proposal sheets duly filled up.
- b) Detailed experience list and financial resources of the Prime Bidder his collaborators/associates in this bid as well as the sub-vendors proposed.
- c) Scheme drawings indicating scope of supply and service as offered by the Bidder indicating clearly exclusions, if any.
- d) List of terminal points of the package offered together with quality and





quantity of various input (i.e. steam, water, air, electricity etc.) as required from the Owner at such interfaces.

- e) Equipment GA, Layout, Design Calculations, interlock and other write-up, catalogues/literature etc. as required for clear understanding of the bid submitted.
- f) High level project schedule network indicating target dates for intermediate milestones and final commissioning of FGD Plant Equipment & auxiliaries; This network shall be supplemented by a detailed write-up on proposed sequence and method of execution for project implementation, deployment schedule for Key personnel with their bio-data, schedule of construction machinery etc.
- g) Subvendor List for the Equipment, as mentioned in Annexure-1, for approval by Owner/Consultant.

8.00.00 CONTRACT STAGE DOCUMENT SUBMISSION AND APPROVAL PROCEDURE

8.01.00 Owner's Engineering schedule shall be submitted by the Bidder as indicated in the specification. Owner's Engineering schedule shall be developed in format as desired by the Owner/consultant.

The documents shall be divided into two categories: a) for approval and b) for information/further Owner's Engineering and co-ordination by the Consultant.

In preparing this schedule, the Bidder shall allow one (1) week from date of receipt for review and comments by the Consultant for each submission of a document.

This document submission schedule shall require acceptance by the Owner/Consultant.

Bidder shall also develop and submit a Master drawing list to the Owner/consultant.

8.02.00 All contract documents shall be marked with the name of the Owner, the Project, the specification title and number and the unit designation.

All dimensions shall be in metric units.

All notes, markings etc. shall be in English.

8.03.00 Documents/Drawings, submitted during tender stage, shall be revalidated or revised as required and submitted as certified contract document for approval/information of the Owner/Consultant.

8.04.00 Unless specified otherwise, the following categories of documents/drawings would require approval of the Owner/Consultant:





**Tender Specification
for
FGD Package**

**NLC Tamil Nadu Power Ltd.
2x500 MW Project
Tuticorin, Tamil Nadu**

- a) System scheme and Process & instrumentation Diagrams (P & IDs).
- b) Design basis documents / memoranda / calculations justifying sizing and selection of equipment, vessels, tanks, piping, valves & specialities as well as the process parameters.
- c) Equipment data sheets and general arrangement drawings.
- d) Materials of construction.
- e) General Arrangement and Layout drawings.
- f) Typical control schemes, circuit diagrams, drive/ feeder-wise control scheme showing all external interfaces.
- g) Control System Configuration
- h) Shop Inspection and Testing Procedures, Test Set-up & Instrumentation, Acceptance Criteria and Codes / Standards followed, correction curves / charts, etc.
- i) Performance Test Procedures, Instrumentation, Acceptance Criteria and Codes / Standards followed, correction curves / charts, etc.
- j) Schedules covering equipment delivery schedules, erection, testing and commissioning schedules at L1 and L2 levels.

8.05.00

Unless specified otherwise, the following categories of documents / drawings would be treated for information/further Owner's Engineering by the Owner/Consultant. The Bidder shall, however, incorporate all additional information and clarifications in these documents/ drawings as and when desired by the Owner/ Consultant.

- a) Equipment foundation drawings.
- b) Equipment cross-section drawings, product literature etc. which are of proprietary nature.
- c) Predicted performance curves of equipment.
- d) Various bills of quantity, schedules etc.
- e) Piping fabrication drawings, isometrics etc.
- f) Panel wiring diagrams.
- g) Instruction/Operation manuals.
- h) Service manuals and trouble shooting guide for C & I system including field instruments.
- i) Operation logic diagrams.





**Tender Specification
for
FGD Package**

**NLC Tamil Nadu Power Ltd.
2x500 MW Project
Tuticorin, Tamil Nadu**

j) Cable schedule and interconnection chart.

In essence, the Bidder is solely responsible for corrections and adequacy of design & Owner's Engineering for documents under this category.

8.06.00 Upon review, the Consultant shall put his remarks and one of the following action stamps on the drawing / document:

- 1) Approved.
- 2) Approved as noted, resubmission required.
- 3) Commented, resubmission required.
- 4) For information/reference only.

For action stamps in category (2) & (3), documents must be resubmitted for review by the Owner/Consultant.

Except for action stamp under category (3), the Bidder can proceed with manufacturing and other sequential activities for those areas of a drawing/document. .

The Consultant may accord approval in category (2) or (3) in more than one submission of a document till he is satisfied that the intent of the specification has been fully complied with. The Bidder shall be responsible for delay in such cases and no extension of time shall ordinarily be allowed on such grounds.

The Bidder's work shall be in strict accordance with the finally approved drawings and no deviation shall be permitted without written approval of the Consultant.

8.07.00 Except key plan/general yard plan, any layout drawing requiring scrutiny shall not be drawn to a scale less than 1:50.

8.08.00 For review by the Consultant, the Bidder shall furnish three (3) prints of each drawing (only for first submission). There upon all transaction of drawings including reviewed comments and stamping shall be done in soft. All transaction of drawings shall be accompanied by a reference letter mentioning the date, revision no. and document status. Only on receiving the Approval Stamping, bidder shall distribute 6 sets of drawings (2 at NLCIL corporate office and 4 sets at NLCIL site office). The Bidder shall furnish three (3) CDs of all as built/final drawings for Owner/Consultant site.

8.09.00 In case of contradiction between the stipulations above and those stated elsewhere in the specification, the more stringent stipulations shall prevail.





ANNEXURE-1 FINALIZATION OF SUB VENDORS

General

- a. The successful Bidder is responsible for performance/guarantee of the complete package including bought out items and out sourced processes. The Bidder will supply the equipment/component/system from the Purchaser/Consultant approved sub vendors only.
- b. The Bidder has to necessarily indicate in their bid, their proposed sub vendors for the items listed below. Sufficient number of sub vendors may be proposed to meet their need.
- c. The proposed list of sub vendors furnished by the Bidder will be reviewed during Techno Commercial/Pre-award discussions by Purchaser/Consultant and the sub vendors will be categorized as below.
 - i. **Category – I: Sub vendors accepted.** The acceptance will be based on past experience of Purchaser/Consultant.
 - ii. **Category – II: Sub vendors enlisted for future acceptance.** Such acceptance will be based on the various details regarding capacity, capability, experience etc of the sub-vendor proposed by the successful Bidder. It is the responsibility of the successful Bidder to get the details of the sub vendors under category II, compiled and submitted to Purchaser/consultant for scrutiny and acceptance. The acceptance criteria are mentioned below. However, Purchaser reserves the right to accept or reject any of the proposed vendors based on information available with them.
- d. The consolidated list of sub vendors under category I and category II will be made available to all the qualified Bidders before price cover opening.
- e. Purchaser may consider the Bidder's proposal for inclusion of new sub vendors, if any during post award stage for approval, based on merits, in the overall interest of the Package, after establishing that the sub vendors proposed meet the acceptance criteria specified. However, price advantage if any, arising out of inclusion of new sub vendors will be passed on to the Purchaser.
- f. Subsequent to approval of main sub vendor for main system after verifying the acceptance criteria, the main sub vendor will be allowed to choose his sub vendors for the sub system provided they meet the technical stipulation as per the contract requirements.
- g. For all other components/equipments/systems which are not figuring in the following list or in the additional list furnished by the Bidder in their bid, Bidder's standard practice of selection of vendors may be carried out.

Acceptance Criteria for Sub Vendors:

- i) **For all Mechanical, Electrical, Control and Instrumentation
(Except for items mentioned under ii and iii below)**





For Class I Items:

Bidder to furnish documentary evidence to show that similar or higher capacity component/equipment / system has been supplied by the vendor or their associate/collaborator and the same has been operating satisfactorily for two years. The documentary evidence will be in the form of Performance certificates furnished by the end user.

For Class II Items:

Bidder to furnish documentary evidence to show that similar or higher capacity component/equipment / system has been supplied by the vendor. The documentary evidence will be in the form of Material Receipt Certificate or Site Inspection Report, etc from the end user for having received the material by the end user.

The component/equipment / system covered under Class I and Class II are furnished below for Mechanical, Electrical, Control and Instrumentation.

ii) For FGD integral control system

(a) In case the Bidder is the Manufacturer of **control system**

1. The offered control system must have been successfully supplied, erected, tested and commissioned in power plant. The system offered should be same as has been rendered to the unit running successfully as mentioned above with proven performance and/ or improved version of the same
2. Bidder shall furnish all required information to fully satisfy Purchaser / Consultant regarding successful operation and high reliability of products / systems furnished.

(b) In case the Bidder is not a Manufacturer of control system, he shall associate with a Vendor who shall satisfy the Clause (a) above.

iii) For Programmable Logic Controller (PLC) / Control System

(a) In case the Bidder is the Manufacturer of PLC:

1. The offered PLC must have been successfully supplied, erected, tested and commissioned for one such system having minimum capacity of 1000 digital inputs in power plants and which should have been in satisfactory operation for not less than two years as on the original date of tender opening.
2. Bidder shall furnish all required information to fully satisfy Purchaser / Consultant regarding successful operation and





high reliability of products / systems furnished.

- (b) In case the Bidder is not a Manufacturer of PLC, he shall associate with a Vendor who shall satisfy the above Clause (a)

iv) For all civil items

- (a) It should confirm to relevant Indian/international Standards.
- (b) It should be of reputed makes supplied to similar construction / infrastructure projects.
- (c) The Bidder should furnish documentary evidence to prove (a) and (b) above

v) For Cement:

- (a) It should confirm to relevant Indian /International Standards.
- (b) It should be of reputed makes supplied to similar construction/infrastructure projects.
- (c) For Cement, minimum quantity of supply shall be 2500 MT for single project.
- (d) The Bidder should furnish documentary evidence to prove (a), (b) and (c) above.

vi) For structural steel & reinforcement steel:

- (a) The quality shall confirm to Indian Standard/International Standards.
- (b) The Firm should have been in the market for a minimum period of 3 years as on the original date of Tender opening and should have supplied & used the structural steel/reinforced steel in any industrial project.
- (c) For reinforcement steel- minimum quantity of supply & used shall be 1000MT for a single project.
- (d) The Bidder should furnish documentary evidence to prove (a) (b) and (c) above

vii) For Structural steel (for use in civil & structural buildings only):

- (a) The quality shall confirm to relevant Indian Standard/International standards.
- (b) The firm should have been in the market for a minimum period of 3 years as on the original date of tender opening and should have supplied & used the structural steel in any industrial project.





- (c) For Structural steel- minimum quantity of supply & used shall be 1000 MT for a single project.
- (d) The Bidder should furnish documentary evidence to prove (a),(b) and (c) above.

viii) For Welding Electrodes:

- (a) The welding electrodes should be confirming to AWS and related BIS.
- (b) The Firm should have executed orders for the supply of electrodes for an order value not less than Rs. 3 lakhs in a calendar year for any or all sizes of the subject electrode within last three(3) years as on the original scheduled date of tender opening..
- (c) The Bidder should furnish documentary evidence to prove (a) & (b) above

ACCEPTANCE CRITERIA FOR SUB CONTRACTORS

ix) For Mechanical and Electrical works:

Contractor to furnish documentary evidence to prove that similar mechanical / electrical erection and installation work had been carried out by the Sub contractor.

x) For Control and Instrumentation works:

(a) In case the C&I vendor is engaging a sub contractor for C&I works Documentation proof shall be furnished in the form of Bid award copy and performance certificate (End user's certificate) to show that similar C&I erection & installation activities were carried out and the job completed satisfactorily by the C&I sub contractor.

(b) For Control Room Architecture: The sub-contractor shall have already executed at least three (3) FGD plant Control Rooms for super critical units in India or abroad with similar operating parameters. Documentary proof shall be furnished for the same.

xi) For Civil & Structural works:

The main Contractor may engage one or more sub contractor for carrying out Civil & Structural works. However, the Civil sub-contractor shall have the following qualifying requirements.

For Civil Works:

- a) He shall have experience in carrying out civil engineering works for Industrial buildings / equipment foundations / high-rise buildings (3 storeys and more) etc.,
- b) He should have executed not less than 10000 Cu.M of R.C.C work in a single agreement.





**Tender Specification
for
FGD Package**

**NLC Tamil Nadu Power Ltd.
2x500 MW Project
Tuticorin, Tamil Nadu**

- c) The work in Sl. Nos (a) & (b) should have been completed within the past 7 years, as on the original scheduled date of tender opening.
- d) Bidder to furnish necessary documentary evidence to prove the above requirements and get approval from the Purchaser, prior to engaging them for civil works.

For Structural works:

- a) He shall have experience in carrying out structural engineering works for Industrial buildings / Power plant structures / high-rise buildings etc.,
- b) Any structural steel works of quantity not less than 2000 MT in a single agreement.
- c) The work in Sl. Nos (a) to (b) should have been completed within the past 7 years, as on the original scheduled date of tender opening.
- d) Bidder to furnish necessary documentary evidence to prove the above requirements and get approval from the Purchaser, prior to engaging them for structural works.

LIST OF EQUIPMENTS – Mechanical

- i) **Class I items: Items for which Performance certificates shall be furnished for approval of Category II sub vendors during detail engineering**

(a) Technological Items

Sl.No	Item Description	Sub Vendors
1.	Limestone Crusher	
2.	Bucket Elevator	
3.	Wet Ball Mills	
4.	Flue Gas Booster fans	
5.	Absorbers	
6.	Oxidation Air Compressors	
7.	All types of Limestone and Gypsum Slurry Pumps	
8.	Ball charging devices	
9.	All types of Hydrocyclones	
10.	Vacuum Belt filter	
11.	Vacuum Pumps	
12.	All types water, waste water and filtrate pumps	
13.	Limestone and Gypsum conveyor components	
14.	Waste water treatment system components	
15.	Seal Air Fans	





Tender Specification
for
FGD Package

NLC Tamil Nadu Power Ltd.
2x500 MW Project
Tuticorin, Tamil Nadu

16.	All types of Vacuum/Pressure vessels	
17.	Mist Eliminator	
18.	Vibration Isolation System	

(b) Air Conditioning & Ventilation System

Sl. No	Item Description	Sub Vendors
1.	Air Conditioning System	
2.	Ventilation System	

(c) Handling & Hoisting

Sl. No	Item Description	Sub Vendors
1.	Elevators	
2.	Double Girder EOT Cranes	
3.	Single Girder Underslung Crane/EOT crane	

(d) DG Set

Sl. No	Item Description	Sub Vendors
1.	DG Set Assemblers.	

- ii) **Class II items: The documentary evidence for approval of Category II sub vendors shall be in the form of Material Receipt Certificate or Site Inspection Report, etc from the end user for having received the material by the end user.**

(a) Technological Items

Sl. No	Item Description	Sub Vendors
1.	Flue Gas Dampers / Gates	
2.	Air and Flue Gas Ducting	
3.	Vibrating Feeders	
4.	Suspended Magnets	
5.	Belt Weighers	
6.	Weigh Belt feeders	
7.	Dry Fog Dust Suppression system	
8.	Dust Extraction system	
9.	Dust Suppression with Plain Water	
10.	Diesel engine	
11.	Slurry Tanks	
12.	Misc. Tanks	





**Tender Specification
for
FGD Package**

NLC Tamil Nadu Power Ltd.
2x500 MW Project
Tuticorin, Tamil Nadu

13.	Ball Valves	
14.	Butterfly Valves	
15.	Steam Trap	
16.	Gate/Globe/ Non Return Valves	
17.	Rubber Expansion Joints	
18.	Safety Valve	
19.	Piping	
20.	Agitators	
21.	Strainers	
22.	Submersible Pumps	
23.	Sump Pumps	
24.	Air Release Valves	
25.	Aluminium sheet	
26.	Thermal Insulation	
27.	Welding electrodes	

(b) HANDLING & HOISTING

Sl. No	Item Description	Sub Vendors
1	Electric Hoists	
2.	Manual Hoists	

(c) Ventilation and Air conditioning

Sl. No	Item Description	Sub Vendors
1.	Split Air Conditioner/Package air conditioner.	

LIST OF EQUIPMENTS –Electrical

Class I items:

Sl. No	Item Description	Sub Vendors
1.	63MVA, 220/11KV FGD Transformer	
2.	Auxiliary Transformers (Oil Filled)	
3.	415 V Switchgear (PCC/PMCC/ MCC)	
4.	ACB	
5.	Auxiliary Relays	
6.	Battery Charger (FC/FCBC)	
7.	Electrical Actuators	
8.	Electro Mechanical Relays	
9.	H.T. Motors	
10.	H.T. Power Cables (XLPE)	
11.	HT Busduct (Segregated Phase)	
12.	HT Switchboard 11KV, 3.3KV	





**Tender Specification
for
FGD Package**

NLC Tamil Nadu Power Ltd.
2x500 MW Project
Tuticorin, Tamil Nadu

13.	L.T. Motors (AC & DC)	
14.	Lighting Transformer	
15.	LT Busduct (Non-Segregated Phase)	
16.	LT Control Cables	
17.	LT Power Cables(XLPE)	
18.	LT Trailing Cables	
19.	LT Transformer (Dry Type)	
20.	MLDB/PDB/ACDB/WDB/ELDB / DCDB / LCP / LPBS / DCLDB	
21.	Neutral Grounding Resistors (NGR)	
22.	Numerical Protection Relays	
23.	Plante Battery	
24.	UPS	
25.	Variable Frequency Drive (VFD)	
26.	VCB	

II) Class II items:

Sl. No	Item Description	Sub Vendors
1.	AC/DC Control Contactors	
2.	AC/DC Power Contactors	
3.	Cable Glands	
4.	Cable Lugs	
5.	Cable Termination & Jointing Kits	
6.	Cable Trays	
7.	Control Transformers	
8.	Current Measuring Modules	
9.	Energy Meters/Multi Function Meters	
10.	High Mast	
11.	Intelligent Controllers	
12.	LED Lighting	
13.	Lighting Fixtures (Flame Proof)	
14.	Lighting Fixtures (General)	
15.	MCCB/MPCB/MCB	
16.	Meters (Analog/Digital)	
17.	Street Light Poles	
18.	Transducer	
19.	CT/PT	

LIST OF EQUIPMENTS – CONTROL & INSTRUMENTATION

Class – I items:

Sl. No	Item Description	Sub Vendors
1.	DDCMIS/PLC System	
2.	Vibration Monitoring System	
3.	Operating stations/Work Stations	
4.	Printers	
5.	Industrial Grade Ethernet Switches	
6.	Smart Transmitter (P, L, F, DP)	





**Tender Specification
for
FGD Package**

NLC Tamil Nadu Power Ltd.
2x500 MW Project
Tuticorin, Tamil Nadu

Sl. No	Item Description	Sub Vendors
7.	Temperature Transmitter	
8.	Thermocouples/ RTDs	
9.	Level Transmitters (Displacer Type)	
10.	Level Transmitters (Ultrasonic, Radar type)	
11.	Flow Elements	
12.	pH Analyser	
13.	Sulphur Dioxide (SO ₂) Analyzer	
14.	Instrument Cables	
15.	Thermocouple cable	
16.	Fibre optic cable	
17.	Control Valves with Smart Positioner	

Class II items:

Sl. No	Item Description	Sub Vendors
1.	Junction Boxes	
2.	LIE / LIR	
3.	Panels/ cabinets	
4.	Control desk, workstation tables, printer tables and chairs, file racks, document storages	
5.	Terminal Blocks	
6.	AC to DC Converter (for Control cabinets)	
7.	Interposing Relays	
8.	Proximity sensor/switch	
9.	Pressure Gauges/DP Gauge	
10.	Temperature Gauges	
11.	Pressure & Differential Pressure Switches, Temperature Switches	
12.	Level Switches (Float , Displacer Type, Capacitance) & Level Gauges	
13.	Level Switches (RF type)	
14.	Level Switches (Conductivity type)	
15.	Flow Switch	
16.	Flow Meters (All type)	
17.	Sight Flow Indicator/Rota Meter	
18.	I/P Converters	
19.	Air Filter Regulator	
20.	Solenoid Valves	
21.	Power Cylinders	
22.	Industrial grade Firewall	
23.	Bulk Material Handling Switches like Pull cord, Zero speed, Belt sway, Chute block, etc.	





LIST OF EQUIPMENTS – Civil & Structural Supply Portion

a. Building Materials

Sl. No	Item Description	Sub Vendors
1.	Flush doors	
2.	Plywood products, particle boards	
3.	Steel doors, windows and ventilators / Pressed door, including accessories	
4.	Aluminium doors, windows, partitions	
5.	FRP Doors including all accessories	
6.	Water proofing compounds/construction chemicals	
7.	Paints and distempers	
8.	Hardware Fittings & Fixtures	
9.	Metallic Floor Hardener	
10.	Water Stops – (PVC/Rubber)	
11.	Expansion Joints	
12.	Water proof cement paints and exterior emulsion paints	
13.	Metal cladding system & Metal deck plate for supporting RCC roof	
14.	Glazing glass / Wired glass	
15.	Tiles	
16.	Hardeners	
17.	PU Coating	
18.	Plasticizer	
19.	SS Pipes	
20.	Door Closer	

b. Sanitary and Water Supply Work

Sl. No	Item Description	Sub Vendors
1.	PVC Pipes & UPVC Pipes and Specials	
2.	G.I. Pipes & Specials	



Sl. No	Item Description	Sub Vendors
3.	W.C. Pan Wash Basin, Urinals Sink Low down flushing Cistern & EWC	
4.	Colour/White Glazed Tiles, Heavy Duty Ceramic tiles and Vitrified Tiles.	

c. RCC Items

Sl. No	Item Description	Sub Vendors
1.	Cement	
2.	Reinforcement Steel	

d. Structural Steel

Sl. No	Item Description	Sub Vendors
1.	Structural Steel	



VOLUME : II-A
SECTION-VII
QUALITY ASSURANCE REQUIREMENTS





CONTENTS

CLAUSE NO.	DESCRIPTION	PAGE NO.
1.00.00	QUALITY ASSURANCE PROGRAMME	1
2.00.00	GENERAL REQUIREMENTS QUALITY ASSURANCE	2
3.00.00	QUALITY ASSURANCE DOCUMENTS	5
4.00.00	INSPECTION, TESTING & INSPECTION CERTIFICATES	6

ATTACHMENT

ANNEXURE-I	FORMAT OF QUALITY ASSURANCE PROGRAMME	8
ANNEXURE-II	FORMAT OF MANUFACTURING QUALITY PLAN	9
ANNEXURE-III	FORMAT OF FIELD QUALITY PLAN	10
ANNEXURE-IV	FORMAT OF FIELD WELDING SCHEDULE	11





VOLUME : II-A

SECTION - VIII

REQUIREMENTS OF SPARES, TOOLS & TACKLES





CONTENTS

CLAUSE NO.	DESCRIPTION	PAGE NO.
1.0	SCOPE	1
2.0	MANDATORY SPARES	1
3.0	TOOLS & TACKLE	1
4.0	GUIDELINES FOR MANDATORY SPARES AND TOOLS AND TACKLE	1
5.0	RECOMMENDED SPARES	2
6.0	START UP AND COMMISSIONING SPARES	3
7.0	GENERAL REQUIREMENTS OF SPARES	3

ATTACHMENTS

ANNEXURE-I	LIST OF MANDATORY SPARES	5
-----------------------	-------------------------------------	--------------





REQUIREMENTS OF SPARES, TOOLS & TACKLES

1.0 Scope

This section covers the general requirements regarding the spares and tools & tackle for all the equipment and systems in the Flue Gas Desulphurisation Plant.

2.0 ~~Mandatory Spares~~

~~The Bidder shall supply in his scope mandatory spares as listed in Annexure I of this Section.~~

~~The supply of mandatory spares shall be started with the consignments of the first unit and completed before the provisional takeover of the first unit and common facilities. However, the spares shall not be dispatched before the dispatch of the main equipment.~~

3.0 Tools and Tackle

1. The Contractor shall supply with the equipment one complete set of all special tools and tackles and other instruments required for the erection, assembly, disassembly and proper maintenance of the plant and equipment and systems (including software). These special tools will also include special material handling equipment, jigs and fixtures for maintenance and calibration / readjustment, checking and measurement aids etc. A list of such tools and tackles shall be submitted by the Bidder along with the offer. The price of each tool / tackle shall be furnished in Price schedule, Volume I.
2. These tools and tackles shall be separately packed and sent to site. The Contractor shall also ensure that these tools and tackles are new and not used by him during erection, commissioning and initial operation. For this period the Contractor should bring his own tools and tackles. All the tools and tackles shall be of reputed make acceptable to the Purchaser.
3. The supply of special tools and tackles shall be started with the consignment of first unit and completed before the provisional takeover of the first unit. However, the tools and tackles shall not be dispatched before the dispatch of the main equipment.

4.0 Guidelines for Mandatory Spares and Tools and Tackle

1. The bidder shall supply the mandatory spares and tools and tackles as listed in Annexure I below.
2. The bidder shall give itemized unit price for the spare parts, tools and tackles while submitting the bid. The Purchaser reserves the right to modify or delete the items/quantity of the spares/tools & tackles. The quoted price for taxes & duties, transport, insurance etc. shall get reduced proportionately to the extent of the value of ordered spares/tools and





**Tender Specification
for
FGD Package**

**NLC Tamil Nadu Power Ltd.
2x500 MW Project
Tuticorin, Tamil Nadu**

tackles. The list of such spares/tools and tackles to be ordered by the Purchaser shall be finalized by the Purchaser before signing of the Contract.

3. In case the description / nomenclature of any of the items of spares/tools and tackles is differing from the description / nomenclature indicated in the list of mandatory spares/tools and tackles, the bidder shall offer functionally equivalent part in lieu of the listed item.
4. In case if such items of spares/tools & tackles indicated as “not applicable”, are found applicable at a later date during execution of the project, such items of spares/tools & tackles are to be supplied within the ordered cost of the mandatory spares.
5. If any of the items of spares/tools & tackles ordered is found to be not applicable during detailed engineering stage/execution stage, the bidder shall have to supply alternative items of spares/tools & tackles. The alternative items of spares/tools & tackles are to be mutually agreed between the PURCHASER and BIDDER.
6. In respect of quantity mentioned as ‘Set’ means the total quantity of all the components/items used in particular equipment unless otherwise specified.

Example-1

One set of spare part which is having four different items of which first item is having 2 similar parts, second one is having 3 similar parts and other two are having one part each, then one set means, combination of 2 similar parts of first item and 3 similar parts of second and one each of 3rd & 4th items.

Example-2

If the quantity of particular spare part is more than one, set means the total no. of similar parts.

7. Wherever % is indicated for the mandatory spares, the quantity shall be calculated for % of supply for total quantity for 2 units of 2 x 500 MW, unless otherwise specified
8. All relevant drawings to identify of spares/tools & tackles are to be furnished when called for by the PURCHASER

5.0 Recommended Spares

1. In addition to the spare parts mentioned above, the Contractor shall also provide a list of recommended spares for three (3) years of normal operation of the plant and indicate the list and total prices in relevant schedule. The list shall take into consideration the mandatory spares specified and should be independent of the list of the mandatory spares. The purchaser reserves the right to buy any or all of the recommended spares. The recommended spares shall be delivered at project site at least





two months before the scheduled date of initial operation of first unit. However, the spares shall not be dispatched before the dispatch of the main equipment.

2. Prices of recommended spares will not be used for evaluation of the bids. The price of these spares will remain valid up to execution of the contract. However, the Contractor shall be liable to provide necessary justification for the quoted prices for these spares if desired by the purchaser.

6.0 Start up and Commissioning Spares

Start up and commissioning spares are those spares which may be required during the start-up and commissioning of the equipment/system till the commercial operation of the Plant. The Contractor shall provide all such start up and commissioning spares and keep an adequate stock of the same to be brought by him to the site for the plant erection and commissioning. These must be available at site before the equipment are energized. The unused spares, if any, should be removed from there only after commercial operation of the plant. All start up spares which remain unused at the time shall remain the property of the Contractor.

7.0 General Requirements of Spares

1. The Contractor shall indicate the service expectancy period for the spares parts (both mandatory and recommended) under normal operating conditions before replacement is necessary.
2. All spares supplied under this contract shall be strictly inter-changeable with the parts for which they are intended for replacements. The spares shall be treated and packed for long storage under the climatic conditions prevailing at the site e.g. small items shall be packed in sealed transparent plastic with desiccator packs as necessary.
3. All the spares (both recommended and mandatory) shall be manufactured along with the main equipment components as a continuous operation as per same specification and quality plan.
4. The contractor will provide purchaser with cross-sectional drawings, catalogues, assembly drawings and other relevant documents so as to enable the purchaser to identify and finalise order for recommended spares.
5. Each spare part shall be clearly marked or labelled on the outside of the packing with its description. When more than one spare part is packed in a single case, a general description of the content shall be shown on the outside of such case and a detailed list enclosed. All cases, containers and other packages must be suitably marked and numbered for the purposes of identification.
6. All cases, containers or other packages are to be opened for such examination as may be considered necessary by the purchaser.
7. The Contractor will provide the purchaser with all the addresses and particulars of his sub-suppliers while placing the order on vendors for items/ components/





**Tender Specification
for
FGD Package**

**NLC Tamil Nadu Power Ltd.
2x500 MW Project
Tuticorin, Tamil Nadu**

equipment covered under Contract and will further ensure with his vendors that the purchaser, if so desires, will have the right to place order for spares directly on them on mutually agreed terms based on offers of such vendors.

8. The Contractor shall warrant that all spares supplied will be new and in accordance with the Contract documents and will be free from defects in design, material and workmanship.
9. In addition to the recommended spares listed by the Contractor, if the purchaser further identifies certain particular items of spares, the Contractor shall submit the prices and delivery quotation for such spares within 30 days of receipt of such request for consideration by the purchaser and placement of order for additional spares if the purchaser so desires.
10. The Contractor shall guarantee the long term availability of spares to the purchaser for the full life of the equipment covered in the Contract. The Contractor shall guarantee that before going out of production of spare parts of the equipment covered under the Contract, he shall give the purchaser at least 2 years advance notice so that the latter may order his bulk requirement of spares, if he so desires. The same provision will also be applicable to Sub-contractors. Further, in case of discontinuance of manufacture of any spares by the Contractor and/or his sub-contractors, Contractor will provide the purchaser, two years in advance, with full manufacturing drawings, material specifications and technical information including information on alternative equipment makes required by the purchaser for the purpose of manufacture/procurement of such items.





VOLUME : II-A
SECTION-IX
SALIENT DESIGN DATA
[TABLE I TO TABLE-VII]





CONTENT

TABLES	DESCRIPTION	PAGE NO.
TABLE-I	DESIGN SEA WATER ANALYSIS	1
TABLE-II	TREATED WATER/ FGD PROCESS WATER ANALYSIS	2
TABLE-III	DESIGN DM WATER ANALYSIS	3
TABLE-IV	COAL AND ASH ANALYSIS	4
TABLE-V	PROPERTIES OF LIGHT DIESEL OIL	5
TABLE-VI	PROPERTIES OF HEAVY FUEL OIL	6
TABLE-VII	PROPERTIES OF LIMESTONE	7





TABLE-I

DESIGN SEA WATER ANALYSIS

Sl. No.	Parameter	Unit	Design Quality
1.	Alkalinity	ppm	122
2.	TH	ppm	6800
3.	Ca Hardness	ppm	1000
4.	Mg hardness	ppm	5800
5.	Cl ⁻	ppm	20226
6.	PO ₄ ³⁻	ppm	0.15
7.	Fe	ppm	0.22
8.	SiO ₂	ppm	2.21
9.	Totals Dissolved Solid(TDS)	ppm	41275
10.	Temperature(⁰ C)	--	26
11.	pH	--	7.47
12.	Conductivity	μs/cm	63500
13.	Turbidity	NTU	500
14.	Total suspended Solids	ppm	500
15.	Total residual Chlorine	ppm	21593 down to 0.1 to 0.5 by Hypo chlorination.*
16.	BOD	ppm	Nil
17.	COD	ppm	Nil
18.	Oil & Grease	ppm	Nil

NOTE- The above water analysis shall be adjusted based on design injection level of chemicals limit of removal of suspended solid in Sea water Pretreatment system to arrive at feed water analysis for Desalination system.

*Further de-chlorination shall be done by the process vendor (if felt necessary) for the RO membrane sustainability.





TABLE-II

TREATED WATER/ FGD PROCESS WATER QUALITY

Sr. Number	Item	Unit	Value
1.	<u>TDS of permeate from Desalination RO System</u>	ppm	<500
2.	Total Suspended solids	ppm	Nil
3.	Iron as Fe	ppm as Fe	<0.1
4.	Reactive Silica as SiO ₂	ppm as SiO ₂	<1.0
5.	Chloride as Cl	ppm as Cl	<200
6.	Sodium	ppm as Na	<150
7.	pH at 25 deg C	---	6.0-7.0



TABLE-III

DESIGN DM WATER ANALYSIS

Sl. No.	Description	Max. Limit
1.00	Total Electrolyte	0.1 ppm, max.
2.00	Total SiO ₂	0.01 ppm, max.
3.00	Iron as Fe	Nil
4.00	Free CO ₂ ppm as CO ₂	Nil
5.00	Total Hardness	Nil
6.00	pH value at 25 Deg.C	6.8 – 7.2
7.00	Conductivity, micro mho/cm	Less than 0.1 at 25 Deg. C



TABLE-IV
COAL AND ASH ANALYSIS

A) COAL ANALYSIS

Sl.No	Description	Unit	Talabira coal-RT-III @0.6 Sulphur
Proximate Analysis (As received basis)			
1	Total moisture	%	4.4
2	Ash	%	44
3	Volatile matter	%	21.1
4	Fixed carbon	%	30.5
Ultimate Analysis (As received basis)			
1	Carbon	C%	44.21
2	Hydrogen	H2%	2.5
3	Nitrogen	N2%	0.94
4	Oxygen (By difference)	O2%	3.35
5	Sulphur	S%	0.6
6	Total Moisture	H2O%	4.4
7	Ash	%	44
8	Gross Calorific Value	kcal/kg	3774

B) ASH ANALYSIS (Provisional)*

Sl. No.	Parameters	Value
a)	LOI	9.84
b)	SiO ₂	42.94
c)	Fe ₂ O ₃	6.97
d)	Al ₂ O ₃	28.65
e)	CaO	5.58
f)	MgO	2.98
g)	SO ₄	3.04

* Ash Analysis is provisional. Final Ash Analysis shall be provided during Detailed Engineering.





TABLE V

PROPERTIES OF LIGHT DIESEL OIL

SL. NO.	PARAMETERS	VALUE
1.	Specification	IS-15770
2.	Acidity (Inorganic)	Nil
3.	Ash content by mass	0.02% (max.)
4.	Copper strip corrosion for 3 hr at 100°C	Not worse than no.2
5.	Flash Point (Pensky-Martens)	66 °C(minimum)
6.	Pour Point (Winter)	12 °C(maximum)
7.	Pour Point (Summer)	18 °C(maximum)
8.	Kinematic Viscosity at 40°C	2.5 to 15.0 Centistokes
9.	Sediment by mass	0.10% (maximum)
10.	Water content by volume	0.25% (maximum)
11.	Total Sulphur by mass	1.5% (maximum)
12.	Carbon Residue (Ramsbottom) by mass	1.5% (maximum)
13.	Gross Calorific Value	10,300 Kcal/kg.
14.	Density at 15 °C	0.85 kg/m ³

Note : Values indicated against Sl. 13 and 14 are typical and are not covered under IS-15770.



TABLE-VI

PROPERTIES OF HEAVY FUEL OIL (HFO)

SL. NO.	PARAMETERS	VALUE
1.	Specification	IS-1593 1971 Heavy Grade
2.	Viscosity at 50°C max.	370 CS
3.	Density at 15°C (approx.)	0.02% (max.)
4.	Flash Point (Pensky-Martens)	66°C(minimum)
5.	Pour Point	50°C(maximum)
6.	Water content by volume	1.0% (maximum)
8.	Sediment by weight	0.25% (maximum)
9.	Sulphur content by weight	4.5% (maximum)
10.	Ash content by weight	0.1% (maximum)
11.	Total Sulphur by weight	1.5% (maximum)
12.	Carbon Residue (Ramsbottom) by weight	-
13.	Gross Calorific Value	10,000 Kcal/kg
14.	Acidity (inorganic)	Nil

Note : For calculation, in case of HFO, 30% wax content with latent heat of fusion 54 Kcal/kg has been assumed.



TABLE-VII

PROPERTIES OF LIMESTONE

Limestone is proposed to be brought by Trucks to the plant. The limestone size is expected to be (-) 250 mm.

1.	CaO	%	47.5-51.0
2.	MgO	%	0.9-2.0
3.	Fe ₂ O ₃	%	0.45-1.0
4.	Al ₂ O ₃	%	1.19-2.1
5.	Si ₂ O ₃	%	2.1-4.5
6.	Mn ₂ O ₃	%	<0.12
7.	P ₂ O ₅	%	Traces
8.	Cl ₂	%	<0.015
9.	Na ₂ O	%	<0.16
10.	K ₂ O	%	<0.01
11.	TiO ₂	%	<0.02
12.	Total Sulphur	%	<0.1
13.	LOI	%	39.0-41.3

Physical Properties:

1.	Bond Index	kWh/t	13
2.	Granule size		Medium



	2X500 MW NTPL TUTICORIN FGD COMPRESSED AIR SYSTEM	SPECIFICATION No: PE-TS-483-555-A002	
		VOLUME: II B	
		SECTION : C2-C	
		REV. 00	DATE: FEB 2022
		SHEET: 1 OF 1	

SECTION: C2-C
PERFROMANCE GUARANTEE TESTS



SECTION-9

PERFORMANCE GUARANTEES

9.0 PERFORMANCE GUARANTEES

9.1 General

The term "Performance Guarantees" wherever appears in the Technical Specifications shall have the same meaning and shall be synonymous to "Functional Guarantees". Similarly the term "Performance Tests" wherever appears in the Technical Specifications shall have the same meaning and shall be synonymous to "Guarantee Test(s)".

9.01 General Requirements

- i) The Bidder shall guarantee that the equipment offered shall meet the ratings and performance requirements stipulated for various equipment covered in these specifications.
- ii) The performance tests shall be carried out in accordance with ASME PTC 40 latest standard. The details of the test shall, however be mutually agreed upon between the Owner and the Bidder.
- iii) The SO₂ emission (mg/Nm³) measurement shall be at a level higher than clean gas entry point and measured individually for each unit with the analyzer mounted on stack.
- iv) The bidder shall ensure sealing efficiency of 100% for FGD bypass damper to minimize the possibility of bypassing untreated gas.
- v) The recirculation pump topmost spare level shall be kept out of service (as standby) during performance guarantee test.
- vi) Bidder shall not use oxalic acid or any other additives during performance Guarantee Test.
- vii) The guaranteed performance parameters furnished by the Bidder in his offer, shall be without any tolerance values whatsoever. All margins required for instrument inaccuracies and other uncertainties shall be deemed to have been included in the guaranteed figures.
- viii) The Bidder shall conduct performance test and demonstrate all the guarantees covered herein under Category I & II. The various tests which are to be carried out during performance guarantee tests are listed in this section. The guarantee tests shall be conducted by the Bidder at site in presence of Owner on each unit individually unless otherwise specified.
- ix) All costs associated with the tests including cost associated with the supply, calibration, installation and removal of the test instrumentation shall be included in the contract price.





- x) It is the responsibility of the Bidder to perform the Performance Guarantee / Acceptance test as specified in this section. The performance tests shall be performed using only the normal number of Owner supplied operating staff. Bidder, vendor or other sub-Bidder personnel shall be used only for instructional purposes or data collection. At all times during the Performance Tests the emissions and effluents from the Plant shall not exceed the Guaranteed Emission and Effluent Limits.
- xi) It shall be responsibility of the Bidder to make the system ready for the performance guarantee tests. The water injection pumps (associated to wet booster fan) will be on during the test.

xii) **Test Instrumentation, Flow Measurement and their Calibration**

All instruments required for performance testing shall be of the type and accuracy required by the code and prior to the test, the Bidder shall get these instruments calibrated in an independent test Institute approved by the Owner. All test instrumentation required for performance tests shall be supplied by the Bidder and shall be retained by him upon satisfactory completion of all such tests at site. All calibration procedures and standards shall be subject to the approval of the Owner. The protecting tubes, pressure connections and other test connections required for conducting guarantee test shall conform to the relevant codes.

Tools and tackles, thermos wells (both screwed and welded) instruments/devices including flow devices, matching flanges, impulse piping & valves etc. and any special equipment, required for the successful completion of the tests, shall be provided by the Bidder free of cost.

- xiii) The Performance test shall be carried out as per the agreed procedure. The PG test procedure including demonstration tests shall be submitted for approval. After the conductance of Performance test, the Bidder shall submit the test evaluation report of Performance test results to Owner promptly but not later than one month from the date of conductance of Performance test. However, preliminary test reports shall be submitted to the Owner after completing each test run.
- xiv) The P&G test procedures shall be submitted for equipment's/ system & subsystem under Bidder's scope for all Guarantees under category I & II as mentioned below, as per latest International codes / standard including correction curves, meeting the specification requirements along with sample calculations & detailed activity plan of preparation (including test instrumentation), conductance and evaluation of Guarantees.
- xv) The Bidder shall submit for Owner's approval the detailed Performance Test procedure containing the following:
- (a) Object of the test
 - (b) Various guaranteed parameters & tests as per contract.
 - (c) Method of conductance of test and test code.
 - (d) Duration of test, frequency of readings & number of test runs.
 - (e) Method of calculation.
 - (f) Correction calculations & curves.





- (g) Instrument list consisting of range, accuracy, least count, and location of instruments.
- (h) Scheme showing measuring points.
- (i) Sample calculation
- (j) Acceptance criteria.
- (k) Any other information required for conducting the test.

xvi) **Test Reports**

After the conductance of Performance test, the Bidder shall submit the test evaluation report of Performance test results to Owner promptly but not later than one month from the date of conductance of Performance test. Preliminary test reports shall be submitted to the Owner after completing each test run. Four (4) hard copies and two (2) soft copies on CD-ROM of each test report of final conducted test on each equipment/plant/system shall be submitted to Owner for approval.

- xvii) In case during performance guarantee test(s) it is found that the equipment/system has failed to meet the guarantees, the Bidder shall carry out all necessary modifications and/or replacements to make the equipment/system comply with the guaranteed requirements at no extra cost to the Owner and re-conduct the performance guarantee test(s) with Owner's consent. In case the specified performance guarantee(s) are still not met by the Bidder even after modification and/or replacement but are achieved within the Acceptable Shortfall Limit Owner will accept the equipment/system/plant after levying the liquidated damages.
- xviii) However, if, the demonstrated guarantee(s) continue to be beyond the stipulated Acceptable Shortfall Limit, even after the above modifications/replacements within ninety (90) days or a reasonable period allowed by the Owner, after the tests have been completed, the Owner will have the right to either of the following:-

a) **For Category-I Guarantees**

Reject the equipment / system / plant and recover from the Bidder the payments already made

OR

Accept the equipment /system/ plant after levying Liquidated Damages. The performance guarantees coming under this category shall be called 'Category-I' Guarantees.

b) **For Category-II Guarantees**

Reject the equipment / system / plant and recover from the Bidder the payments already made

OR

Accept the equipment/system after assessing the deficiency in respect of the various ratings, performance parameters and capabilities and recover from the contract price an amount equivalent to the damages as determined by the Owner. Such damages shall, however be limited to the cost of replacement of the equipment(s)/system(s), replacement of which shall remove the



deficiency so as to achieve the guaranteed performance. These parameters/capacities shall be termed as "Category-II" Guarantees.

9.2 GUARANTEES PARAMETERS

9.2.1 Guarantees under Category-I

The Performance Guarantees which attract Liquidated Damages (LD) are as follows & shall be performed for each unit individually.

i) SO₂ Emission

The bidder shall guarantee their best SO₂ removal efficiency with inlet SO₂ concentration corresponding to performance/design coal firing and 500 MW unit load. However, SO₂ removal efficiency shall not be less than 91.34% (continuous) under guarantee point condition.

ii) Limestone consumption of FGD system

The Bidder shall guarantee the Limestone consumption of FGD system in kg/hr under conditions as specified in Clause 9.2.1(i) above.

iii) Auxiliary Power Consumption

The Bidder shall guarantee the total auxiliary power consumption for the FGD plant in normal operating condition at conditions, as specified in Clause 9.2.1(i) above. The list of equipment's to be considered for auxiliary power consumption guarantee are specified.

AUXILIARY POWER CONSUMPTION (PA)

The unit auxiliary power consumption shall be calculated using the following relationship.

$$P_a = P_u + T_L$$

P_a = Guaranteed Auxiliary Power Consumption.

P_u = Power consumed by the auxiliaries of the unit under test.

T_L = Losses of the transformers supplied by bidder based on works test reports.

While guaranteeing the auxiliary power consumption the bidder shall necessarily include all continuously operating auxiliaries under this package. The auxiliaries to be considered shall include the following:

- i) Absorber Recirculation Pump(s)
- ii) Absorber Oxidation Air Blower(s)/Compressor(s)
- iii) Absorber Oxidation Tank Agitators
- iv) Gypsum Bleed Pumps





- v) Limestone Gravimetric feeder, Wet ball mill and their integral Auxiliaries.
- vi) Mill Recycle pumps.
- vii) Limestone Slurry Pump(s)
- viii) Vacuum Belt Filter, Vacuum Pump
- ix) Process water pump(s)
- x) Mist Eliminator Wash Water pump(s)
- xi) Booster Fans.
- xii) 50% of the power consumption of Limestone Slurry Tank Agitators.
- xiii) 50% of the power consumption of Reclaim water Pump(s)
- xiv) Gypsum cake Wash Water Pump.
- xv) Secondary Hydro-cyclone feed Pump.
- xvi) Lime stone working crusher – 20% of the total power consumption of crusher while crushing lime combined for three units together.
- xvii) Gypsum transfer conveyer.
- xviii) Limestone belt conveyor- 20% of the total power consumption of all the three units combined together
- xix) DMCCW Pumps(actual figure; (for the three unit) will be divided by three for each unit)
- xx) 50 % of the power consumption of the waste water sump pump & Waste Water Pumps.
- xxi) 50% of the power consumption of all other continuous running agitators.
- xxii) Any other continuous running equipments.

**Note:**

- 1) The Category-I Guarantees which attracts liquidated damage shall be performed together individually for each unit at 500 MW TMCR condition.
- 2) Bidder shall consider the power consumption of common auxiliaries for Lime & gypsum handling & preparation system as per duty factor indicated for the guarantee of auxiliary power consumption of each unit.
- 3) The Bidder shall not consider the following equipment's/system in the list of Auxiliary Power Consumption Guarantee.
 - a) Elevators
 - b) Air Conditioning System
 - c) Lighting load.

9.3 AMOUNT OF LIQUIDATED DAMAGES (LD) APPLICABLE FOR GUARANTEES (UNITFGD WISE)

The rate of liquidated damages and acceptable shortfall limits for different guarantees as specified in category-I are mentioned as under.

S.No.	GAURANTEE	RATE OF LIQUIDATION DAMAGE (LD)
i)	For shortfall in guaranteed SO ₂ removal efficiency in percentage	INR 3,350,000/-(Indian Rupees Thirty Three Lakh fifty thousand only) For every 0.1% point shortfall in SO ₂ removal efficiency from the Guaranteed value for each unit.
ii)	For increase in the limestone consumption of FGD system in Kg/hr	INR 13,012,500/-(Indian Rupees One crore, thirty lakh twelve thousand five hundred only) For every 100 kg/hr increase in Limestone consumption from guaranteed value
iii)	Auxiliary Power Consumption For increase in the auxiliary power consumption in KW guaranteed	INR 4,06,500/-(Indian Rupees Four Lakh Six Thousand Five Hundred only) For every KW increase in Auxiliary power consumption from the guaranteed value.

NOTE:

- i) Each of the liquidated damages specified above shall be independent and these liquidated damages shall be levied concurrently as applicable.
- ii) All these liquidated damages for short fall in performance shall be deducted from the contract price as detailed in the Contract.

9.4 List of Correction Curves

The following correction curve shall be applicable for performance test of FGD system:-





- a) Lime Stone purity vs Lime stone Consumption.
- b) Inlet Gas flow rate vs Water Consumption
- c) Gypsum purity vs Limestone Quality.
- d) SO₂ emission level vs Inlet Gas Flow rate.
- e) SO₂ emission level vs Inlet SO₂ concentration.
- f) Water Consumption vs Inlet Gas Temperature.
- g) Pressure drop across terminal point Vs inlet Gas flow rate
- h) Inlet dust level vs collection efficiency

9.5 Guarantees Under Category-II

i) Wet ball Mill

The followings Guarantees are to be covered for wet ball mill individually for each unit.

a) Capacity at rated fineness

The Bidder shall demonstrate the guaranteed capacity of each limestone pulverizer under the following conditions:

1. Limestone fineness: 90% or higher (as per the requirement of the absorber) through 325 mesh (for spray tower process) OR 90% or higher (as per the requirement of the absorber) through 200 mesh (for jet bubbling process).
2. Limestone Quality: All available quality from the specified range.

The Lime stone quality shall be as per the availability & within the specified range as mentioned elsewhere in the specification. Bidder shall demonstrate the above capacity with the originally installed grinding elements in nearly worn-out condition.

3. Individual Wet ball mill capacity as specified elsewhere in the specification shall be demonstrated with corresponding reduction in adjacent mill loading & its auxiliaries feeding to three absorbers.

b) Wet ball Mill ball consumption

Bidder shall guarantee ball consumption per ton of limestone throughput in line with requirements stipulated in elsewhere in tender specification.

Bidder shall furnish the minimum ball diameter below which the balls shall be replaced.

c) Wet Ball wear parts

Bidder shall demonstrate the life of wet ball mill wear parts in line with requirement stipulated in Design Basis.





ii) Booster Fan & pressure drop across FGD system

a) Performance characteristics of Booster fans

The performance characteristics (capacity, head developed) of two booster fans running together shall be demonstrated with performance/design coal firing & 500 MW Unit Load.

b) Margin on Booster fans

The margin (flow & head) (as specified) on any one booster fan as per Owner choice shall be demonstrated with corresponding reduction in other fan.

c) Pressure Drop across FGD

The Bidder shall demonstrate that the total pressure drop in the gas path across the FGD system within the terminal points (as specified) for each unit shall not exceed the guaranteed figure at 500 MW unit load with design/performance coal firing & range of limestone analysis specified.

iii) Vacuum Belt Filter Capacity

Bidder shall demonstrate the capacity of the any one Vacuum Belt Filters as per Owners choice to dewater the quantity of gypsum with the specified purity and moisture content as specified in elsewhere in tender specification.

iv) Gypsum Purity & Moisture Content

The Bidder shall demonstrate that the purity of the gypsum produced for each unit shall not be less than 84%, chloride content shall not be more than 100ppm for the limestone analysis as specified for the guarantee point and the moisture content shall not be more than 10% for the range of specified coal(s) and limestone.

v) Stack inlet temperature

Bidder shall demonstrate that the stack inlet temperature for each unit with FGD system in operation, is more than or equal to guaranteed figure at 500 MW unit load & design/performance coal firing.

vi) Moisture in flue gas

Increase in Moisture (water content) in flue gas

vii) Outlet dust burden at FGD Outlet.

Bidder shall demonstrate the outlet dust level (mg/Nm^3) for each unit corresponding to inlet dust content of $100 \text{ mg}/\text{Nm}^3$ at FGD inlet with performance/design coal firing & 500 MW Unit load.



viii) Outlet SO₂ Emission with inlet dust level

The outlet SO₂ emission (mg/Nm³) shall not exceed corresponding to the SO₂ removal efficiency as specified in Vol-II B, Sec-I at 500 MW & performance/design coal firing.

No correction factor is applicable upto inlet dust level of 50 mg/Nm³ at FGD system inlet. The correction curve will only be applicable for inlet dust level exceeding 50 mg/Nm³ to demonstrate the above mentioned guarantee.

ix) Make-up Water

The total make-up water required individually for each unit at 500 MW unit load & design/performance coal firing shall be demonstrated by the bidder.

x) Waste Water

The bidder shall guarantee that the maximum purge flow rate to waste water treatment system for the complete plant over a 24 hours period.

xi) Mist outlet droplet count

The mist eliminator droplet content shall be guaranteed to be ≤ 20 mg/Nm³ at absorber outlet measured over period of 24 hrs. Continuous operation. Mist outlet droplet content shall be measured as per VDI norm 3679 and the contractor shall carry out the tests as per the test procedure approved by the employer.

xii) Capabilities of all major Electric drives

The capabilities of the following drives for one set of each type shall be demonstrated as per Owners choice.

- a) Booster fan
- b) Recirculation Pump
- c) Limestone slurry pumps
- d) Gypsum bleed pumps
- e) Oxidation air Blower

xiii) Passenger cum Goods Elevator for FGD absorber: Over load tests, travel and hoist speed checks.

xiv) Noise

All the plant, equipment and systems covered under this specification shall perform continuously without exceeding the noise level over the entire range of output and operating frequency as specified in elsewhere in tender specification.

Noise level measurement shall be carried out using applicable and internationally acceptable standards. The measurement shall be carried out with a calibrated integrating sound level meter meeting the requirement of IEC 651 or BS 5969 or is 9779.





Sound pressure shall be measured all around the equipment at a distance of 1.0 m horizontally from the nearest surface of any equipment/ machine and at a height of 1.5 m above the floor level in elevation.

xv) Capacity of Lime & Gypsum Handling Equipment:

The Bidder shall demonstrate the capacity of bucket elevators, Belt Conveyor and Lime Crusher capacity of any one set as per Owners Choice and as specified elsewhere in the specification

9.6 Liquidated Damages for Non Performance

1. Should the results of the formal test show that the FGD system has failed to meet its guarantee, the Contractor shall carry out the modification at its own cost, if considered necessary, to meet the guaranteed values. In such a case the performance and guarantee tests shall be repeated by the Contractor within one (1) month from the date the equipment is ready for retest. If the specified guarantees are not established within 90 days of notification by the Purchaser, the Purchaser may at his discretion reject the equipment and recover the payments already made or accept the equipment after assessing the liquidated damages payable at the rates specified in Cl 9.3 of this Schedule for each FGD system. The recovery of such amount shall be from the amounts due to the Contractor. These liquidated damages shall be prorated for fractional parts of the deficiencies.
2. Specific performance guarantees which attract liquidated damages are detailed in Cl.9.3 of this schedule.
3. Other performance parameters as detailed in Clause 9.5 of this schedule, which do not attract liquidated damages, shall be termed as demonstration parameters. Demonstration parameters / capabilities shall be demonstrated during the trial operation period/guarantee tests of the respective system/equipment as per the detailed test procedure to be approved by the Purchaser/Consultant.



2X500 MW NTPL TUTICORIN FGD

COMPRESSED AIR SYSTEM

SPECIFICATION No: PE-TS-483-555-A002

VOLUME: II B

SECTION : C2-D

REV. 00

DATE: FEB 2022

SHEET: 1 OF 1

SECTION: C2-D
QUALITY ASSURANCE



VOLUME : II-A

SECTION-VII

QUALITY ASSURANCE REQUIREMENTS

1.00.00 QUALITY ASSURANCE PROGRAMME

1.01.00 To ensure that the equipment and services under the scope of Contract whether manufactured or performed within the Successful Bidder's works or at his Sub-Vendor's premises or at the Owner's site or at any other place or work are in accordance with the specifications, the Successful Bidder shall adopt suitable quality assurance programme to control such activities at all points, as necessary. Such programmes shall be outlined by the Successful Bidder and shall be finally accepted by the Owner/ Authorised representative after discussions before the award of contract. A quality assurance programme of the Successful Bidder shall generally cover the following:

- a) His organisation structure for the management and implementation of the proposed quality assurance programme.
- b) Documentation control system.
- c) Qualification data for Bidder's key personnel.
- d) The procedure for purchase of materials, parts, components and selection of Sub-Vendor's services including vendor analysis, source inspection, incoming raw-material inspection, verification of materials purchased etc.
- e) System for shop manufacturing and site erection control including process controls and fabrication and assembly controls.
- f) Control of non-conforming items and system for corrective actions.
- g) Inspection and test procedure both for manufacture and all site related works.
- h) Control of calibration and testing of measuring and testing equipments.
- i) System for quality audit.
- j) System for indication and appraisal of inspection status.
- k) System for authorising release of manufactured product to the Owner.





- l) System for handling storage and delivery.
- m) System for maintenance of records.
- n) Furnishing of quality plans for manufacturing and field activities detailing out the specific quality control procedure adopted for controlling the quality characteristics relevant to each item of equipment/component as per format enclosed at Annexure-I to this section.

2.00.00 GENERAL REQUIREMENTS - QUALITY ASSURANCE

2.01.00 All materials, components and equipment covered under this specification shall be procured, manufactured and tested at all the stages, as well as Services provided for erection, commissioning and testing shall be as per a comprehensive Quality Assurance Programme. An indicative programme of inspection/tests to be carried out by the Bidder for some of the major items is given in the respective technical specification. This is however, not intended to form a comprehensive programme as it is the Bidder's responsibility to draw up and implement such programme and reviewed by by the Owner/Consultant. The detailed Quality Plans for manufacturing and field activities should be drawn up by the Bidder, separately in the format attached at Annexure-I and will be submitted to Owner/Owner's representative for review. Schedule of finalisation of such quality plans will be finalised before award.

2.02.00 Manufacturing Quality Plan will detail out for all the components and equipment, various tests/inspection, to be carried out as per the requirements of this specification and standards mentioned therein and quality practices and procedures followed by Bidder's Quality Control organisation, the relevant reference documents and standards, acceptance norms, inspection documents raised etc., during all stages of materials procurement, manufacture, assembly and final testing/performance testing.

2.03.00 Field Quality Plans will detail out for all the equipment, the quality practices and procedures etc. to be followed by the Bidder's site Quality Control organisation, during various stages of site activities from receipt of materials/equipment at site.

After pipe lines have been laid and joined, the same shall be tested hydrostatically as specified in this section. Additionally, random inspection of UT shall be carried out by a certified third party agency for 10% of welded joints in addition to 10% Radiography test (RT) , 100% Ultrasonic Test (UT) on all welded joints.

All the longitudinal and circumferential welded seams shall be subjected to chalk and kerosene test prior to hydraulic testing. This shall be done at the presence of the Owner. In addition to this, test coupons shall have to be provided for each longitudinal seams for mechanical tests (tensile and bend), if considered necessary by the Owner. The test coupons are to be broken in presence of the Owner. Bidder shall satisfy the Owner that work is being carried out in accordance with the specification drawings and other conditions. Owner shall have full access to the Bidder's working area.





**Tender Specification
for
FGD Package**

**NLC Tamil Nadu Power Ltd.
2x500 MW Project
Tuticorin, Tamil Nadu**

Bidder's scope of supply for fabrication, erection, cleaning, testing and commissioning of the piping systems installed by him shall include the following:-

All welding consumables like welding electrodes, filler rods and wires; gases like oxygen, acetylenes, argon, carbon-dioxide, propane, backing rings etc.

Films for radiographic examination of welds.

X-ray and Gamma -ray equipment including isotopes, dye penetrants, and other required non-destructive testing materials and equipment (all to be taken back by the Bidder after completion of work).

All heating and stress relieving equipment, thermocouples asbestos blankets, cables, temperature recorders, charts heat sensitive chalks and crayons etc. (All to be taken back by bidder after completion of work).

All machinery, equipment tools and tackles as required for transportation handling, fabrication and erection (All to be taken back by Bidder after completion of work).

All equipment/ materials as required for cleaning, flushing, blowing out and hydro testing of the piping systems; these shall include but not be limited to pumps and compressors with prime movers, instruments, pipe work with supports, valves, strainers and other specialties, blanks, plugs, spool pieces, dummy plates, electrical accessories, etc. (All to be taken back by Bidder after completion of work).

All scaffolding materials and false work (To be taken back by Bidder after completion of work).

2.04.00 The Bidder shall also furnish copies of the reference documents/plant standards/acceptance norms/tests and inspection procedure etc., as referred in Quality Plans along with Quality Plans. These Quality plans and reference documents/standards etc. will be subject to Consultant's approval without which manufacture shall not proceed. In these approved quality plans, Owner/Authorised representative/Consultant shall identify Customer Hold Points (CHP), test/checks which shall be carried out in presence of the Owner/Consultant/Owners Owner's Engineer or his Authorised Representative and beyond which the work will not proceed without consent of Owner/Authorised representative/Consultant in writing.

All deviations to this specification, approved quality plans and applicable standards must be documented and referred to Owner/Authorised Representative/Consultant for acceptance and dispositioning.

2.05.00 The Bidder shall provide adequate notice to the Owner for inspection before the material is dispatched as per the provisions of the Contract. No material shall be despatched from the manufacturer's works before the same is accepted subsequent to pre-despatch final inspection including verification of records of all previous tests/inspections by Owner's Owner's Engineer/Authorised





**Tender Specification
for
FGD Package**

**NLC Tamil Nadu Power Ltd.
2x500 MW Project
Tuticorin, Tamil Nadu**

representative, and duly authorised for despatch issuance of Material Despatch Clearance Certificate (MDCC).

2.06.00 All materials used or supplied shall be accompanied by valid and approved materials certificates and tests and inspection report. These certificates and reports shall indicate the sheet numbers or other such acceptable identification numbers of the material. The material certified shall also have the identification details stamped on it.

2.07.00 All the individual and assembled rotating parts shall be statically and dynamically balanced in the works.

Where accurate alignment is necessary for component parts of machinery normally assembled on site, the Bidder shall allow for trial assembly prior to despatch from place of manufacture.

2.08.00 Castings and forgings used for construction shall be of tested quality. Details of results of chemical analysis, heat treatment record, mechanical property test results shall be furnished.

2.09.00 All welding and brazing shall be carried out as per procedure drawn and qualified in accordance with requirements of ASME Section-IX/BS-4870 or other International equivalent standard acceptable to the Owner.

All brazers, welders etc. employed on any part of the contract at Bidder's/Sub-Vendor's works or at site shall be qualified as per ASME Section-IX or BS-4871 or equivalent international standard approved by the Owner. Such qualification tests shall be conducted in presence of Owner/his authorised representative.

For welding of pressure parts and high pressure piping the requirements of IBR shall also be complied with.

Under no circumstances any repair or welding of castings be carried out without the consent of the Owner. Proof of the effectiveness of each repair by radiographic and/or other non-destructive testing technique, shall be provided to the Owner.

All pressure parts shall be subjected to hydraulic testing as per the requirements of IBR. Other parts shall be tested for one and half times the maximum operating pressure, for a period not less than thirty (30) minutes.

2.10.00 All non-destructive examination (NDT) shall be carried out in accordance with approved international standard. The NDT operator shall be qualified as per SNT-TC-1A (of American Society of non- destructive examination). Results of NDT shall be properly recorded and submitted for acceptance.

All welding procedures adopted for performing welding work shall be qualified in accordance with the requirements of Section-IX of ASME code or IBR as applicable. All welded joints for pressure parts shall be tested by liquid penetrant examination according to the method outlined in ASME Boiler and Pressure Vessel code. Radiography, magnetic particle examination and ultrasonic testing shall be employed wherever necessary/ recommended by the





**Tender Specification
for
FGD Package**

**NLC Tamil Nadu Power Ltd.
2x500 MW Project
Tuticorin, Tamil Nadu**

applicable code. At least 10% of all major butt welding joints shall be radiographed. Statutory payments in respect of IBR approvals including inspection shall be made by Bidder. Bidder's scope and responsibility shall also include preparation and submission of all necessary documents in the specific formats and manner stipulated by the statutory bodies, coordination and follow up for above approvals.

2.11.00 All the Sub-Vendors proposed by the Bidder for procurement of major bought out items including castings, forgings, semi-finished and finished components/equipment list of which shall be drawn up by the Bidder and finalised with the Owner shall be subject to Owner's review. Quality Plans of the successful Sub-Vendors shall be discussed, finalised and accepted by the Owner/Authorised representative and form part of the Purchase Order between the Bidder and the Sub-Vendor.

2.12.00 All the purchase specifications for the major bought-out items, list of which shall be drawn up by the Bidder and finalised with the Owner shall be furnished to the Owner for comments and subsequent acceptance before orders are placed.

Owner reserves the right to carry out quality audit and quality surveillance of the systems and procedures of the Bidder's or their Sub-Vendor's quality management and control activities. The Bidder shall provide all necessary assistance to enable the Owner carry out such audit and surveillance.

Quality audit/acceptance of the results of tests and inspection will not prejudice the right of the Owner to reject equipment not giving the desired performance after erection and shall not in no way limit the liabilities and responsibilities of the Bidder in earning satisfactory performance of equipment as per specification.

2.13.00 Quality requirements for main equipment shall equally apply for spares and replacement items.

2.14.00 Repair/rectification procedures to be adopted to make any job acceptable shall be subject to the acceptance of the Owner.

2.15.00 For quality assurance of all civil works refer to the specifications for civil works.

3.00.00 QUALITY ASSURANCE DOCUMENTS

3.01.00 The Bidder shall be required to submit two (2) copies and two (2) sets of microfilms of the following Quality Assurance documents within three (3) weeks after despatch of the equipment:

- a) Material mill test reports on components as specified by the specification.
- b) The inspection plan with verification, inspection plan check points, verification sketches, if used and methods used to verify that the inspection and testing points in the inspection plan were performed satisfactorily.





**Tender Specification
for
FGD Package**

**NLC Tamil Nadu Power Ltd.
2x500 MW Project
Tuticorin, Tamil Nadu**

- c) Non-destructive examination results /reports including radiography interpretation reports.
- d) Factory tests results for testing required as per applicable codes and standards referred in the specification.
- e) Welder identification list listing welder's and welding operator's qualification procedure and welding identification symbols.
- f) Sketches and drawings used for indicating the method of traceability of the radiographs to the location on the equipment.
- g) Stress relief time temperature charts.
- h) Inspection reports duly signed by QA personnel of the Owner and Bidder for the agreed inspection hold points. During the course of inspection, the following will also be recorded :
 - i) When some important repair work is involved to make the job acceptable.
 - ii) The repair work remains part of the accepted product quality.
- i) Letter of conformity certifying that the requirement is in compliance with finalised specification requirements.

4.00.00 INSPECTION, TESTING AND INSPECTION CERTIFICATES

4.01.00 The Successful Bidder shall give the Owner's Engineer/Inspector fifteen (15) days written notice of any material being ready for testing. Such tests shall be to the Successful Bidder's account except for the expenses of the Inspector. The Owner's Engineer/Inspector, unless the witnessing of the tests is virtually waived, will attend such tests within fifteen (15) days of the date on which the equipment is notified as being ready for test/inspection failing which the Successful Bidder may proceed with test which shall be deemed to have been made in the Inspector's presence and he shall forthwith forward to the Inspector duly certified copies of test reports in six (6) copies.

4.02.00 The Owner's Engineer or Inspector shall within fifteen (15) days from the date of Inspection as defined herein give notice in writing to the Successful Bidder, or any objection to any drawings and all or any equipment and workmanship which is in his opinion not in accordance with the contract. The Successful Bidder shall give due consideration to such objections and shall either make modifications that may be necessary to meet the said objections or shall confirm in writing to the Owner's Engineer/Inspector giving reasons therein, that no modifications are necessary to comply with the contract.

4.03.00 When the factory tests have been completed at the Bidder's or sub-Vendor's works, the Owner/Inspector shall issue a certificate to this effect fifteen (15) days after completion of tests but if the tests are not witnessed by the Owner/Inspectors, the certificate shall be issued within fifteen (15) days of the receipt of the Bidder's test certificate by the Owner/Inspector. Failure of the





Tender Specification
for
FGD Package

NLC Tamil Nadu Power Ltd.
2x500 MW Project
Tuticorin, Tamil Nadu

Owner/Inspector to issue such a certificate shall not prevent the Bidder from proceeding with the works. The completion of these tests, or the issue of the certificates shall not bind the Owner to accept the equipment should it, on further tests after erection be found not to comply with the contract.

4.04.00

The Bidder shall furnish quarterly inspection programme indicating schedule dates of inspection at customer hold point and final inspection stages. Updated quarterly inspection plans will be made for each three consecutive months and shall be furnished before beginning of each calendar month.





**Tender Specification
for
FGD Package**

**NLC Tamil Nadu Power Ltd.
2x500 MW Project
Tuticorin, Tamil Nadu**

ANNEXURE-I : FORMAT OF QUALITY ASSURANCE PROGRAMME

Name of Company/ Successful Bidder	NAME OF CONTRACT PACKAGE	QUALITY PLAN FOR								
	Package No. : _____ Bidderr : _____	QP No. : _____ Date _____ Rev.No.: _____ Date _____								
Sl. No.	Component & Operation	Characteristics	Class	Type of Check	Quantum of Check	Reference Document	Acceptance Norm	Format of Record	Agency	Remarks



Development Consultants Pvt. Ltd.

**Vol. II-A/Section-VII
Quality Assurance Requirements**



Tender Specification
for
FGD Package

NLC Tamil Nadu Power Ltd.
2x500 MW Project
Tuticorin, Tamil Nadu

ANNEXURE-II: MANUFACTURING QUALITY PLAN

MFGR.'s LOGO		MANUFACTURER'S NAME AND ADDRESS		MANUFACTURING QUALITY PLAN				PROJECT :			REMARKS		
								ITEM :				PACKAGE :	
				SUB-SYSTEM:			CONTRACT NO. :						
							MAIN-SUPPLIER :						
SL. NO	COMPONENT & OPERATIONS	CHARACTERISTICS	CLASS	TYPE OF CHECK	QUANTUM OF CHECK	REFERENCE DOCUMENT	ACCEPTANCE NORMS	FORMAT OF RECORD	AGENCY			REMARKS	
1.	2.	3.	4.	5.	6.	7.	8.	9.	D*	M	C		L
				LEGEND: * RECORDS, IDENTIFIED WITH "TICK" (✓) WILL BE ESSENTIALLY INCLUDED BY SUPPLIER IN QA DOCUMENTATION. ** M: MANUFACTURER/SUB-SUPPLIER C: SUPPLIER/NOMINATED INSPECTION AGENCY, L: PURCHASER P: PERFORM W: WITNESS AND V: VERIFICATION. AS APPROPRIATE, CHP: PURCHASER WILL IDENTIFIED IN COLUM "N"				DOC. NO.:		REV.....			
								CAT.....					
MANUFACTURER/ SUB-SUPPLIER		MAIN-SUPPLIER						FOR PURCHASE R USE					
SIGNATURE								REVIEWED BY		APPROVED BY		APPROVAL SEAL	



Development Consultants Pvt. Ltd.

Vol. II-A/Section-VII
Quality Assurance Requirements



Tender Specification
for
FGD Package

NLC Tamil Nadu Power Ltd.
2x500 MW Project
Tuticorin, Tamil Nadu

MFGR.'s LOGO		SUPPLIER'S NAME AND ADDRESS		ANNEXURE – III: FIELD QUALITY PLAN				PROJECT :					
SL. NO		ACTIVITY AND OPERATION		CHARACTERISTICS / INSTRUMENTS		CLASS# OF CHECK	TYPE OF CHECK	QUANTUM OF CHECK	REFERENCE DOCUMENT	ACCEPTANCE NORMS	FORMAT OF RECORD		REMARKS
1.		2.		3.		4.	5.	6.	7.	8.	9.	D*	10.
				LEGEND: * RECORDS, IDENTIFIED WITH "TICK" (√) WILL BE ESSENTIALLY INCLUDED BY SUPPLIER IN QA DOCUMENTATION. LEGEND TO BE USED: CLASS # : A = CRITICAL, B=MAJOR, C=MINOR; 'A' WILL BE WITNESSED BY PURCHASER FQA, 'B' WILL BE WITNESSED BY PURCHASER ERECTION / CONSTRUCTION DEPTT. AND 'C' WILL BE WITNESSED BY CONTRACTOR (A & B CHECK WILL BE PURCHASER CHP STAGE)					DOC. NO.: REV.....				
MANUFACTURER/ SUB-SUPPLIER		MAIN-SUPPLIER						FOR PURCHASE R USE	REVIEWED BY	APPROVED BY	APPROVAL SEAL		
SIGNATURE													
FORMAT NO.:				1/1				Engg. Div. / QA&I					



Development Consultants Pvt. Ltd.

Vol. II-A/Section-VII
Quality Assurance Requirements



**Tender Specification
for
FGD Package**

**NLC Tamil Nadu Power Ltd.
2x500 MW Project
Tuticorin, Tamil Nadu**

ANNEXURE-IV : FIELD WELDING SCHEDULE

PROJECT : FWS NO :

BIDDER : REV NO. :

PACKAGE : FIELD WELDING CODE :

SYSTEM : PAGE NO. :

Sl No.	Drawing No. for Weld Locations & Identification mark	Description of parts to be welded	Material specification	Dimensions	Process of Welding	Type of Weld	Electrode Filler Specification	WPS No.	Minimum Preheat Temperature	Heat Treatment Temperature [Holding Time in secs]	NDT Method Quantum	NDT Specification Number	Acceptance Norm Ref.	Remarks

The Field Welding Schedule should be submitted for :

- Pressure Parts
- Tanks/Vessels
- Piping
- Heavy/Important Structural Steel
- Heat Exchangers
- Bus Ducts



Development Consultants Pvt. Ltd.

**Vol. II-A/Section-VII
Quality Assurance Requirements**

Introduction to the Quality Assurance Specification:

For fulfilment of the relevant clauses (regarding Testing,Inspection etc.) of the General Conditions of Contract and General Technical Requirements of Contract, the Quality Assurance Specification acts as a part of the Technical Specification and is included in the Contract.

This part of the Technical Specification shall be read in conjunction with other parts of the technical specifications, General Technical Requirements and Erection Conditions of the Contract.

This document specifies the quality requirements, to be detailed in terms of Tests/Checks/Procedures to be followed at the times of manufacturing,Testing, Inspection and also during installation of various Equipment / Components at the place of manufacturer and / or on the site.

Various standards referred in this document shall be the latest revisions.

The quality requirements are spelt out in the following ways;

- 1) Through description
- 2) In tabular form

In either of the above two formats the tests /checks / procedures that are required to be performed are mentioned against particular item/ equipment/ component/ system etc.

This specification also contains the Indicative vendor list (with disclaimer) mentioned against particular item/ equipment/ component/ system etc.

The quality requirements specified in this document and also the vendor list are only indicative and not exhaustive.



SECTION-11

QUALITY ASSURANCE

11 QUALITY ASSURANCE

Quality System for Inspection & Testing of Plant & Equipment at Manufacturer's Premises

11.1 General

- i) Inspection & testing of plant & equipment shall be carried out by NLCIL/NTPL at the works of successful bidder (Contractor/Sub-contractor) during manufacturing and on final product to ensure conformity of the same with acceptable criteria of technical specifications, approved drawings, authenticated manufacturing drawings and reference national / international standards.
- ii) This specification is in addition to provisions laid-down elsewhere in Purchaser's Draft Contract and special instructions to tenderers, if any.
- iii) Contractor must recognise the importance of quality and follow defined quality programme in all manufacturing and quality control activities of the product. Contractor must define and implement the tasks and controls that shall provide needed assurance in case manufacturing of product is sub contracted either partly or fully and/or for the procured components of the product.
- iv) Purchaser/ Consultant reserve the right to verify the quality programme and entire product characteristics to assure the intended and specified quality of the product.
- v) The inspection, examination or testing carried out by the purchaser shall not relieve the contractor from any of his obligation under this contract. The inspection procedure shall be discussed and finalised.

11.2 Quality Assurance Plan (QAP)

- i) Inspection and test requirements shall be decided with due consideration of factors like safety, duty cycle, operating conditions, equipment life, environmental conditions, place of installation and statutory regulations, as applicable, for a particular equipment.
- ii) Detailed QAP shall be prepared by Contractor in consultation with Sub-contractors / Manufacturers to avoid any complication later.
- iii) QAP shall clearly indicate the followings:
 - (a) Range of inspection & tests to be done by Manufacturers and cross checked by Contractor during manufacture of equipment from raw materials to finishing stage.
 - (b) Suggestive check/ hold points for Purchaser's Inspection and witnessing of tests during the manufacturing and final product inspection.



- (c) Inspection documents to be furnished by Contractor/ Manufacturers to Purchaser for reference during inspection.

11.3 Internal Inspection by Contractor / Manufacturer

- i) Inspection and tests shall be carried out by Contractor/ Manufacturer in accordance with approved drawings, Tender Specification, Purchase Order, and approved QAP. Contractor/ Manufacturer shall maintain record of each inspection and test carried out and signed documents shall be submitted to purchaser for verification.
- ii) Contractor shall carry out their internal inspection & obtain clearance from statutory bodies e.g. IBR, CCE, TAC, Weights & Measures, safety, IE rules etc. However, Purchaser shall carry out inspection as agreed in approved QAP prior to Contractor offering the equipment for statutory clearance.
- iii) All the measuring & test instruments shall be calibrated by manufacturers and record of the same shall be maintained for purchaser's scrutiny. Contractor shall ensure use of appropriate calibrated measuring & test instruments during their internal inspection, as well as, make available the same for purchaser's inspection and tests. Calibration standard shall be national standard, if existing. Otherwise, manufacturers' own standard & calibration procedure shall be accepted. Valid calibration certificates traceable to national/ international standards shall be submitted to purchaser during / prior to inspection.
- iv) Contractor / Manufacturers shall identify all the inspected equipment/component/raw materials & shall maintain the record of status of inspection viz. inspected & found acceptable, require rectification/rework, rejected etc.
- v) The Contractor shall establish and maintain procedures to ensure that product that does not conform to specified requirements, is prevented from inadvertent use or installation. The description of non-conformity that has been accepted subsequently by Designer / Purchaser by concession and/or of repairs, shall be recorded and forms part of the subsequent drawings / schedules relevant to the products.
- vi) Repaired and reworked product shall be offered for re- inspection to purchaser along with records of corrective action taken.
- vii) Contractor / Manufacturer shall not despatch any equipment till receipt of despatch clearance from purchaser.

11.4 Method of Undertaking Inspection & Testing By Purchaser

11.4.1 Agency Responsible

Inspection/Waiver of equipment shall be undertaken by purchaser.

11.4.2 Method of Issuing Inspection Call to Purchaser

Inspection call shall be given only on readiness of the equipment/ assembly/ sub-assembly and approval of all relevant drawings and QAP. In case, equipment/





assembly/ sub-assembly offered for inspection are found not ready, all the cost of visit of purchaser's engineer shall have to be borne by the Contractor.

11.4.3 Obligations of Contractor

- i) Contractor shall provide all facilities and ensure full and free access of the Inspection Engineer of purchaser to the Contractor's or their Sub-Contractor's premises at any time during contract period, to facilitate him to carry out inspection & testing of the product during or after manufacture of the same.
- ii) The Contractor shall delegate a Representative / Co-ordinator to deal with purchaser on all inspection matters. Also, Contractor's Representative shall be present during all inspection at Sub-Contractor's works.
- iii) The Contractor shall comply with instructions of the Inspection Engineer fully and promptly.
- iv) The Contractor / Sub-Contractor shall provide all instruments, tools, necessary testing & other inspection facilities to Inspection Engineer free of cost for carrying out inspection.
- v) The cost of testing welds by ultrasonic, radiographic and dye penetration tests etc. in the fabrication workshop shall be borne by the Contractor.
- vi) The Contractor shall ensure that the equipment / assembly /component of the plant and equipment required to be inspected, are not dismantled or despatched before inspection.
- vii) The Contractor shall not offer equipment for inspection in painted condition unless otherwise agreed in writing by purchaser.
- viii) The Contractor shall ensure that the equipment and materials once rejected by the Inspection Engineer, are not re-used in the manufacture of the plant and equipment. Where parts rejected by the Inspection Engineer have been rectified as per agreed procedures laid down in advance, such parts shall be segregated for separate inspection and approval, before being used in the work.

11.4.4 Stamping and issue of inspection documents

i) Inspection Memo

For stage inspection and for rejected items/items which do not conform to Technical specification in one or more quality characteristics requiring rectification/rework, Inspection memo shall be issued in standard form indicating therein the details of observation and remarks. All the non-conformities with respect to specification of the product shall be indicated in the inspection memo for further control by manufacturer.

ii) Inspection Certificate

On satisfactory completion of final inspection and testing, an inspection Certificate in standard form shall be issued by the Inspection engineer for the accepted items.



iii) Inspection Waiver Certificate

For the inspection waiver category of items identified in the approved QAP, Purchaser shall issue Inspection Waiver Certificate.

11.5 General Clauses

- i) Inspection & tests carried out by purchaser shall not absolve the responsibility of the Contractor/ Manufacturer to provide acceptable product nor shall it preclude subsequent rejection.
- ii) Purchaser reserve the right to inspect any product at any stage of manufacturing without prior notice to Contractor/Manufacturer beyond pre-identified stages & hold points of approved QAP. The inspection mentioned in this clause is meant for Purchaser getting apprised of status of manufacturing and not to obstruct the manufacturing program of the Contractor.



**2X500 MW NTPL TUTICORIN FGD
COMPRESSED AIR SYSTEM**

SPECIFICATION No: PE-TS-483-555-A002

VOLUME: II B

SECTION : C-3

REV. 00

DATE: FEB 2022

SHEET: 1 OF 1

**SECTION: C-3
TECHNICAL SPECIFICATION (ELECTRICAL PORTION)**

714945/2022/PS-PEM-MAX

	TITLE: ELECTRICAL EQUIPMENT SPECIFICATION FOR COMPRESSED AIR SYSTEM 2X500 MW NTPL TUTICORIN FGD	SPECIFICATION NO.
		VOLUME NO. : II-B
		SECTION: I
		REV NO. : 00 DATE: 20.02.2021
		SHEET: 1 OF 1

CONTENTS

SECTION	TITLE	NO OF SHEETS
I	SPECIFIC TECHNICAL REQUIREMENTS	3
I	ELECTRICAL SCOPE BETWEEN BHEL & VENDOR (ANNEURE-I)	2
I	ELECTRICAL LOAD DATA FORMAT (ANNEXURE-II)	1
I	CABLE SCHEDULE FORMAT (ANNEXURE-III)	1
I	TECHNICAL SPECIFICATION FOR MOTORS	13
I	MOTOR DATASHEET-A	1
I	MOTOR DATASHEET-C	2
II	STANDARD SPECIFICATION FOR LV MOTORS	5
II	REFERENCE QUALITY PLAN	11
II	TECHNICAL SPECIFICATION FOR CABLE TRAYS & ACCESSORIES	5
II	TYPICAL DETAILS OF CABLE TRAYS AND ACCESSORIES	2

The requirements mentioned in Section-I shall prevail and govern in case of conflict between the same and the corresponding requirements mentioned in the descriptive portion in Section-II.

	ELECTRICAL EQUIPMENT SPECIFICATION FOR COMPRESSED AIR SYSTEM 2X500 MW NTPL TUTICORIN FGD	SPECIFICATION NO.
		VOLUME NO. : II-B
		SECTION : I
		REV NO. : 00 DATE : 20.02.2021
		SHEET : 2 OF 3

1.0 EQUIPMENT & SERVICES TO BE PROVIDED BY BIDDER:

- a) Services and equipment as per “Electrical Scope between BHEL and Vendor”.
- b) Any item/work either supply of equipment or erection material which have not been specifically mentioned but are necessary to complete the work for trouble free and efficient operation of the plant shall be deemed to be included within the scope of this specification. The same shall be provided by the bidder without any extra charge.
- ~~c) Supply of mandatory spares as specified in the specifications of mechanical equipments.~~
- d) Electrical load requirement for COMPRESSED AIR SYSTEM (all AC & DC loads at different voltage levels like 415V AC, 240 V AC, 220 V DC etc).
- e) All equipment shall be suitable for the power supply fault levels and other climatic conditions mentioned in the enclosed project information.
- f) Bidder to furnish list of makes for each equipment at contract stage, which shall be subject to customer/BHEL approval without any commercial and delivery implications to BHEL
- g) Various drawings, data sheets as per required format, Quality plans, calculations, test reports, test certificates, operation and maintenance manuals etc shall be furnished as specified at contract stage. All documents shall be subject to customer/BHEL approval without any commercial implication to BHEL.
- h) Motor shall meet minimum requirement of motor specification.
- i) Vendor to clearly indicate equipment locations and local routing lengths in their cable listing furnished to BHEL.
- j) Cable BOQ worked out based on routing of cable listing provided by the vendor for “ both end equipment in vendor’s scope”shall be binding to the vendor with +10 % margin to take care of slight variation in routing length & wastages.

2.0 EQUIPMENT & SERVICES TO BE PROVIDED BY PURCHASER FOR ELECTRICAL & TERMINAL POINTS:

Refer “Electrical Scope between BHEL and Vendor”.

3.0 DOCUMENTS TO BE SUBMITTED ALONG WITH BID

3.1 The electrical specification without any deviation from the technical/quality assurance requirements stipulated shall be deemed to be complied by the bidder in case bidder furnishes the overall compliance of package technical specification in the form of compliance certificate/No deviation certificate.

3.2 No technical submittal such as copies of data sheets, drawings, write-up, quality plans, type test certificates, technical literature, etc, is required during tender stage. Any such submission even if made, shall not be considered as part of offer.

714945/2022/PS-PEM-MAX:



**ELECTRICAL EQUIPMENT SPECIFICATION
FOR
COMPRESSED AIR SYSTEM**

2X500 MW NTPL TUTICORIN FGD

SPECIFICATION NO.

VOLUME NO. : **II-B**

SECTION : **I**

REV NO. : **00** DATE : **20.02.2021**

SHEET : 3 OF 3

4.0 List of enclosures :

- a) Electrical scope between BHEL & vendor (Annexure –I)
- b) Technical specification for motors.
- c) Datasheets & quality plan for motors.
- d) Electrical Load data format (Annexure –II)
- e) BHEL cable listing format (Annexure –III)

ELECTRICAL SCOPE BETWEEN BHEL AND VENDOR

PACKAGES : COMPRESSED AIR SYSTEM

SCOPE OF VENDOR: SUPPLY, ERECTION & COMMISSIONING OF VENDOR'S EQUIPMENT

PROJECT: 2X500 MW NTPL TUTICORIN FGD

<u>S.NO</u>	<u>DETAILS</u>	<u>SCOPE SUPPLY</u>	<u>SCOPE E&C</u>	<u>REMARKS</u>
1	11 kV/ 6.6 KV / 3.3 KV / 415 V Switchgear	BHEL	BHEL	240 V AC (supply feeder)/415 V AC (3 PHASE 4 WIRE) supply shall be provided by BHEL based on load data provided by vendor at contract stage for all equipment supplied by vendor as part of contract. Any other voltage level (AC/DC) required will be derived by the vendor.
2	Local Push Button Station (for motors)	BHEL	BHEL	Located near the motors.
3	Power cables, control cables and screened control cables for a) both end equipment in BHEL's scope b) both end equipment in vendor's scope c) one end equipment in vendor's scope	BHEL BHEL BHEL	BHEL Vendor BHEL	1. For 3.b) & c): Sizes of cables required shall be informed by vendor at contract stage (based on inputs provided by BHEL) in the form of cable listing. Finalisation of cable sizes shall be done by BHEL. Vendor shall provide lugs & glands accordingly. 2. Termination at BHEL equipment terminals by BHEL. 3. Termination at Vendor equipment terminals by Vendor.
4	Junction box for control & instrumentation cable	Vendor	Vendor	Number of Junction Boxes shall be sufficient and positioned in the field to minimize local cabling (max 10-12 mtrs) and trunk cable.
5	Any special type of cable like compensating, co-axial, prefab, MICC, etc.	Vendor	Vendor	Refer C&I portion of specification for scope of fibre Optical cables if used between PLC/ microprocessor & DCS.
6	Cable trays, accessories & cable trays supporting system. 100/50 mm cable trays/Conduits/Galvanised steel cable troughs for local cabling	BHEL Vendor	BHEL Vendor	Local cabling from nearby main route cable tray (BHEL scope) to equipment terminal (vendor's scope) shall be through 100/ 50 mm. cable trays/ conduits/ Galvanised steel cable troughs as per approved layout drawing during contract stage.
7	Cable glands, lugs & bimetallic strip for equipments supplied by Vendor	Vendor	Vendor	1. Double compression Ni-Cr plated brass cable glands 2. Solder less crimping type heavy duty tinned copper lugs for power & control cables.
8	Conduit and conduit accessories for cabling between equipments supplied by vendor.	Vendor	Vendor	Conduits shall be medium duty, hot dip galvanised cold rolled mild steel rigid conduit as per IS: 9537.
9	Lighting	BHEL	BHEL	--
10	Equipment grounding (including electronic earthing) & lightning protection	BHEL	BHEL	Refer note no. 4 for electronic earthing
11	Below grade grounding	BHEL	BHEL	--
12	Motors with base plate and foundation hardware	Vendor	Vendor	Makes shall be subject to customer/ BHEL approval at contract stage.
13	Mandatory spares	Vendor		Vendor to quote as per specification.

ELECTRICAL SCOPE BETWEEN BHEL AND VENDOR**PACKAGES : COMPRESSED AIR SYSTEM****SCOPE OF VENDOR: SUPPLY, ERECTION & COMMISSIONING OF VENDOR'S EQUIPMENT****PROJECT: 2X500 MW NTPL TUTICORIN FGD**

14	Recommended O & M spares	Vendor	-	As specified elsewhere in specification
15	Any other equipment/material/service required for completeness of system based on the system offered by vendor (to ensure trouble free and efficient operation of the system).	Vendor	Vendor	--
16	a. Input cable schedules (C & I) b. Cable interconnection detail for the above c. Cable block diagram	Vendor Vendor Vendor	- - -	Cable listing for Control and Instrumentation Cable and electronic earthing cable in enclosed excel format shall be submitted by vendor during detailed engineering stage.
17	Cabling layout drawings	BHEL/ Vendor	-	a. In case of Compressor are HT motors, cable tray/trench layout inside compressed air building shall be prepared by BHEL. Vendor to furnish drawing (both in print form as well as in AUTOCAD) of compressor room layout clearly indicating all motors, panels, JB's etc. which require cabling along with their terminal box/location/ Foundation etc. b. In case of Compressor are LT motors, for ensuring cabling requirements are met, vendor shall prepare & submit cable tray/trench & equipment layout (both in print form as well as in AUTOCAD) of the complete plant (including electrical area) indicating location and identification of all equipment requiring cabling for BHEL review & approval.
18	Electrical equipment GA drawing	Vendor	-	For necessary interface review.

NOTES:

1. Make of all electrical equipments/items supplied shall be reputed make & shall be subject to approval of BHEL/customer after award of contract.
2. All QPs shall be subject to approval of BHEL/customer after award of contract without any commercial implication.
3. In case the requirement of junction box arises on account of power cable size mismatch due to vendor engineering at later stage, vendor shall supply the junction box for suitable termination.
4. Vendor shall indicate location of Electronic Earth pit in their Civil assignment drawing.

LOAD TITLE	RATING (KW / A)		UNIT (U)/STN (S)	Nos.		VOLTAGE CODE*	FEEDER CODE**	EMER. LOAD (Y)	CONT.(C)/INTT.(I)	STARTING TIME >5 SEC (Y)	LOCATION	BOARD NO.	CABLE		BLOCK CABLE DRG. No.	CONT ROL CODE	REMA RKS	LOAD No.	VERIFICATI ON FROM MOTOR DATASHEE T (Y/N)	KKS NO
	NAME PLATE	MAX. CONT. DEMAND (MCR)		RUNNING	STANDBY								SIZE CODE	NOs						
1	2	3	4	5	6	7	8	9	10	11	12	13	14	15	16	17	18	19	20	21

ANNEXURE-II

NOTES: 1. COLUMN 1 TO 12 & 18 SHALL BE FILLED BY THE REQUISITIONER (ORIGINATING AGENCY); REMAINING COLUMNS ARE TO BE FILLED UP BY PEM (ELECTRICAL)/ CUSTOMER
 2. ABBREVIATIONS : * VOLTAGE CODE (7):- (ac) A=11 KV, B=6.6 KV, C=3.3 KV, D=415 V, E=240 V (1 PH), F=110 V (cc): G=220 V, H=110 V, J=48 V, K=+24V, L=-24 V
 : ** FEEDER CODE (8):- U=UNIDIRECTIONAL STARTER, B=BI-DIRECTIONAL STARTER, S=SUPPLY FEEDER, D=SUPPLY FEEDER (CONTACTER CONTROLLED)

		PROJECT TITLE	2X500 MW NTPL TUTICORIN FGD	NAME		DATA FILLED UP ON	
		SYSTEM	COMPRESSED AIR SYSTEM	SIGN.		DATA ENTERED ON	
		DEPTT. / SECTION	MAX	SHEET 1 OF 1	REV. 00	DE'S SIGN. & DATE	179 of 439

714945/2022/PS-PEM-MAX



Tender Specification
for
FGD Package

NLC Tamil Nadu Power Ltd.
2x500 MW Project
Tuticorin, Tamil Nadu

VOLUME: II-F/SECTION-II

A.C. & D.C. MOTORS



Development Consultants Pvt. Ltd.

Vol. II-F/Section-II
A.C. & D.C. Motors



CONTENTS

CLAUSE NO.	DESCRIPTION	PAGE NO.
1.00.00	Scope	1
2.00.00	Codes & Standards	1
3.00.00	Service Conditions	1
4.00.00	Type and Rating	1
5.00.00	Performance	3
6.00.00	Specific Requirements	5
7.00.00	Accessories	7
8.00.00	Tests	9
9.00.00	Drawings, Data & Manuals	9
ATTACHMENT		
ANNEXURE-A	Design Data	11





VOLUME: II-F

A.C. & D.C. MOTORS

1.00.00SCOPE

- 1.01.0 This specification covers the general requirements of the electric motors for Limestone based flue gas de-sulphurisation system.
- 1.02.00Motors shall be furnished in accordance with both this general specification and the accompanying driven equipment specification.
- 1.03.00 In case of any discrepancy, the driven equipment specification shall govern.
- 1.04.00 Recommended spare parts for three (3) years operation in addition to mandatory spares

2.00.00CODES & STANDARDS

- 2.01.00All motors shall conform to the latest applicable IS, IEC and CBIP Standards/Publications except when otherwise stated herein or in the driven equipment specification.
- 2.02.00 Equipment and materials conforming to any other standard, which ensures equal or better quality may be accepted. In such case, copies of the English version of the standard adopted shall be submitted along with the bid.

3.00.00SERVICE CONDITIONS

- 3.01.00The motors shall be installed in hot, humid and tropical atmosphere, highly polluted area.
- 3.02.00 Unless otherwise noted, electrical equipment/system design shall be based on the service conditions and auxiliary power supply given in the annexure to this specification.
- 3.03.00 For motor installed outdoor and exposed to direct sunrays, the effect of solar heat shall be considered in the determination of the design ambient temperature.

4.00.00 TYPE AND RATING

4.01.00A.C. Motors

- 4.01.01 Motors shall be general purpose, constant speed, squirrel cage, three/single phase, induction type.
- 4.01.02All motors shall be either totally enclosed fan cooled (TEFC) or totally enclosed tube ventilated (TETV) or closed air circuit air cooled (CACA) or closed air water





cooled (CACW) type. Temperature rise shall be limited to 70 deg C by resistance method for class F insulation.

4.01.03 All motors shall be rated for continuous duty (S1). They shall also be suitable for long period of inactivity.

4.01.04 All LT motor shall conform to minimum efficiency performance standards (MEPS) of IE3 mentioned in IS: 12615. All HT motors shall have efficiency and power factor higher than 90% and 0.83 power factor respectively.

4.01.05 The motor name plate rating at 50^oC shall have at least 15% margin for LT system and 10% margin for HT system, over the input power requirement of the driven equipment at rated duty point and also covering the maximum load demand of the driven equipment under entire operating range, including voltage and frequency variations, unless stated otherwise in driven equipment specification or in general electrical specification.

4.01.06 The motor characteristics shall match the requirements of the driven equipment so that adequate starting, accelerating, pull up, break down and full load torques are available for the intended service. The direction of rotation of motor and its cooling fan should be properly matched with the driven equipment.

4.02.00 AC motor for VFD application

4.02.01 Inverter duty motors are designed according to the requirements of IEC/TS- 60034 part 17 & part 25 or NEMA MG-1, Part-30, Part 31 and have performance characteristics match with the driven equipment and variable speed requirement.

4.02.02 Induction motors to be operated in adjustable-speed drive applications should be de-rated as per NEMA/IEC standard due to the reduction in cooling resulting from any reduction in operating speed and the effect of additional losses introduced by harmonics generated by the control.

4.02.03 Inverter duty motors shall have VPI/improved insulation systems that do not degrade readily due to transient voltage spikes and have an adequate thermal margin.

4.02.04 Inverter duty motors shall be self-ventilated without any auxiliary blower. Force ventilation shall be subject to purchaser approval.

4.02.05 Inverter motor shall be suitable for scalar (open loop) control, without any speed feedback signal, where fast response is not required. Vector (closed loop) control will be used with encoder if specified.

4.02.06 The breakdown torque at any frequency within the defined frequency range shall be not less than 150% of the rated torque at that frequency when rated voltage for that frequency is applied.

4.02.07 The motor should be capable of producing a breakaway torque of at least 140% of rated torque requiring not more than 150% rated current when the voltage





boost is adjusted to develop rated flux in the motor and when the inverter is able to produce the required minimum fundamental frequencies.

4.02.08 The motor shall be provided with insulated bearing on one side.

4.02.09 Normally the maximum safe speed shall be as per IEC/NEMA, however it should be co-ordinated with VSD requirement.

4.02.10 In case of a conflict, the requirement mentioned under clause no. 4.02.00 for motors for VFD application shall supersede the corresponding requirement for standard motors.

4.03.00 D.C. Motors (If applicable)

4.03.01 D.C. motor provided for emergency service shall be shunt wound type. It can also be of compound-wound type with the series field shorted.

4.03.02 Motor shall be sized for operation with fixed resistance starter for maximum reliability. Starter panel complete with all accessories shall be included in the scope of supply.

5.00.00 PERFORMANCE

5.01.00 Running Requirements

5.01.01 Motor shall run continuously at rated output over the entire range of voltage and frequency variations as given in the annexure.

5.01.02 The motor shall be capable of operating satisfactorily at full load for 5 minutes without injurious heating with 75% rated voltage at motor terminals. The mill motors shall be suitable for operating at 75% of rated voltage for one (1) minute

5.02.00 Starting Requirements

5.02.01 Motor shall be designed for direct on line starting at full voltage. Starting current shall not exceed 600% of full load current (subject to IS tolerance of 20%) for HT motors rated upto 1000kW. For HT motors above 1000kW upto 3000kW starting current shall not exceed 600% of full load current without any positive tolerance. For HT motors above 3000kW starting current shall not exceed 450% of full load current without any positive tolerance.

For LT motors the starting current shall be as per the limit mentioned in the relevant standard with IE-3 efficiency class. For D.C. Motors the starting current shall be limited to 2 times full load current.

5.02.02 The motor shall be capable of withstanding the stresses imposed if started at 110% rated voltage.

5.02.03 All motors (except mill motors) shall start with rated load and accelerate to full speed with 80% rated voltage at motor terminals. Mill motors shall start with rated load and accelerate to full speed with 85% of rated voltage.





5.02.04 Motor shall be capable of three equally spread starts per hour, two starts in quick succession from cold condition and one restart from hot condition.

Cold Motor Starting

Under specified voltage variations two (2) starts in quick succession and third start five (5) minutes thereafter, all with full load (including loaded equipment) of driven equipment. No additional start shall be made till lapse of further thirty (30) minutes.

(b) Hot Motor Starting

Under specified voltage variations, one (1) immediate and two (2) fifteen (15) minutes interval starts all with full load (including loaded equipment) of driven equipment. No additional start shall be made till lapse of further thirty (30) minutes.

(c) Motor shall also be suitable for three (3) equally spread starts per hour when the motor is under normal service condition.

5.02.05 Pump motor subject to reverse rotation shall be designed to withstand the stresses encountered when starting with non-energized shaft rotating at 125% rated speed in reverse direction.

5.03.00 Stress During Bus Transfer

5.03.01 Motors subjected to bus transfer shall be suitable for sudden application of 150% rated voltage during bus transfer, due to the phase difference between the incoming voltage and motor residual voltage.

5.03.02 The motor shall be designed to withstand any torsional and/or high current stresses, which may result, without experiencing any deterioration in the normal life and performance characteristics.

5.04.00 Locked Rotor Withstand Time

5.04.01 For motors with starting time up to 20 secs, starting time at minimum permissible voltage should be less than the locked rotor withstand time under hot condition at highest voltage limit by at least 2.5 secs.

For motors with starting time more than 20 secs. and upto 45 secs, starting time at minimum permissible voltage should be less than the locked rotor withstand time under hot condition at highest voltage limit by at least 5 secs.

For motors with starting time more than 45 secs, starting time at minimum permissible voltage should be less than the locked rotor withstand time under hot condition at highest voltage limit by at least 10% of the starting time.

5.04.02 To prevent unwanted tripping of a high inertia load at start-up, there may be need to shunt out the motor's overload trip device. Speed switches mounted





on the motor shaft may be provided in such case. Heating experienced during start-up must still be considered when sizing the motor.

5.04.03 Hot thermal withstand curve shall have a margin of at least 10% over the full load current of the motor to permit relay setting utilising motor rated capacity.

5.05.00 Torque Requirements

5.05.01 Accelerating torque at any speed with the lowest permissible starting voltage shall be at least 10% motor full load torque.

5.05.02 Pull out torque at rated voltage shall not be less than 205% of full load torque.

6.00.00 SPECIFIC REQUIREMENTS

6.01.00 Enclosure

6.01.01 All motor enclosures and terminal boxes shall conform to the degree of protection IP-55 unless otherwise specified. Motor for outdoor or semi-outdoor service shall be of weather-proof construction.

Motors, located inside a building and not directly exposed to coal dust or fly ash, could have screen protected drip proof enclosure conforming to IP-23.

6.01.02 Motor located in hazardous area shall have flameproof enclosure conforming to IS: 2148 /Equiv.

6.03.00 Cooling

6.03.01 The motor shall be self ventilated type, either totally enclosed fan cooled (TEFC) or closed air circuit air- cooled (CACA).

6.03.02 For large capacity motors, totally enclosed tube ventilated (TETV) may be considered for acceptance. In case of motors rated 3000kW and above, closed air circuit water cooled (CACW) motors may be offered for consideration before proceeding with design and manufacturing.

6.04.00 Winding and Insulation

6.04.01 All insulated winding shall be of copper.

6.04.02 HT and LT motors shall have Class F insulation with winding temperature limited to 120°C. Windings shall be impregnated to make them non-hygroscopic and oil resistant. The lightning impulse and coil inter-turn insulation surge withstand level shall be as per IEC-60034 – Part 15.

6.05.00 Tropical Protection

6.05.01 All motors shall have fungus protection involving special treatment of insulation and metal against fungus, insects and corrosion.





6.05.02 All fittings and hardwares shall be corrosion resistant.

6.06.00 Bearings

6.06.01 Motor rated above 1000kW shall have insulated bearings to prevent flow of shaft currents.

6.06.02 Vertical shaft motors shall be provided with thrust and guide bearings.

6.07.00 Noise & Vibration

6.07.01 The noise level shall not exceed 85 db (A) at 1.0 meters from the motor.

6.07.02 Peak amplitude of vibration shall be limited within the values prescribed in IS: 12075 / IEC 60034-14.

6.08.00 Motor Terminal Box

6.08.01 Motor terminal box shall be detachable type, made of cast iron or pressed steel and located in accordance with Indian Standards clearing the motor base-plate / foundation.

6.08.02 Terminal box shall be capable of being turned 360 Deg. in steps of 90 Deg., unless otherwise approved.

6.08.03 The terminal box shall be split type with removable cover with access to connections and shall have the same degree of protection as motor. Terminal box for all LT motors shall be diagonally split type.

6.08.04 The terminal box shall have sufficient space inside for termination / connection of XLPE (11000V/3300V) or XLPE (415V) insulated armoured aluminium cables. Where the specified main cable size demands, adopter / extension box of suitable size shall be provided as a part integral to the motor, for easy termination of the cable.

6.08.05 Terminals shall be stud or lead wire type, substantially constructed and thoroughly insulated from the frame.

6.08.06 The terminals shall be clearly identified by phase markings, with corresponding direction of rotation marked on the non-driving end of the motor.

6.08.07 The terminal box shall be capable of withstanding maximum system fault current for a duration of 0.25 sec.

6.08.08 For 11000V and 3300V motor, the terminal box shall be phase-segregated type. The neutral leads shall be brought out in a separate terminal box (not necessarily phase segregated type) with shorting links for star connection.

6.08.09 Motor terminal box shall be furnished with suitable cable lugs and double compression brass glands to match with cable used.





6.08.10 The gland plate for single core cable shall be non-magnetic type.

6.08.11 Motors rated 1000kW and above shall be provided with neutral current transformers of PS class on each phase in a separate neutral terminal box for differential protection.

6.09.00 Grounding

6.09.01 The frame of each motor shall be provided with two separate and distinct grounding pads complete with tapped hole, GI bolts and washer.

6.09.02 The grounding connection shall be suitable for accommodation of ground conductors as follows:

Motor above 90KW	:	50 x 6 mm GS Flat
Motor above 30KW up to 90KW	:	25 x 6 mm GS Flat
Motor above 5KW up to 30KW	:	25 x 3 mm GS Flat
Motor up to 5KW	:	8 SWG GI Wire

6.09.03 The cable terminal box shall have a separate grounding pad.

6.10.00 Rating Plate

In addition to the minimum information required by IS, the following information shall be shown on motor rating plate:

- a) Temperature rise in Deg.C under rated condition and method of measurement.
- b) Degree of protection (IP No.).
- c) Bearing identification no. and recommended lubricant.
- d) Location of insulated bearings.

7.00.00 ACCESSORIES

7.01.00 General

Accessories shall be furnished, as listed below, or if otherwise required by driven equipment specification or application.

7.02.00 Space Heater

7.02.01 Motor of rating 30KW and above shall be provided with space heaters, suitably located for easy removal or replacement.





7.02.02 The space heater shall be rated 240V, 1 phase 50Hz and sized to maintain the motor internal temperature above dew point when the motor is idle.

7.03.00 Temperature Detectors

7.03.01 All 11000V and 3300V motors shall be provided with minimum four (4) numbers simplex or two (2) numbers duplex platinum resistance type winding temperature detectors per phase.

7.03.02 11000V and 3300V motor bearing shall be provided with one (1) duplex or two (2) simplex type temperature detectors.

7.03.03 The temperature detector mentioned above shall be resistance type, 3 wire, platinum wound, 100 Ohms at 0 deg.C.

Leads of all duplex or simplex type motor winding RTDs and motor bearing RTDs shall be wired up to respective switchgear metering & protection compartment. From which one set of RTDs shall be connected to numerical protection relay and another set shall be kept free for DDCMIS connectivity.

7.04.00 Indicator/Switch

7.04.01 Dial type local indicator with alarm contacts shall be provided for the following:

- a) 11000V and 3300V motor bearing temperature.
- b) Hot and cold air temperature of the closed air circuit for CACA and CACW motor.

7.04.02 Flow switches shall be provided for monitoring cooling water flow of CACW motor and oil flow of forced lubrication bearing, if used.

7.04.03 Alarm switch contact rating shall be minimum 0.5A at 220V D.C. and 5A at 240V A.C.

7.05.00 Current Transformer for Differential Protection

7.05.01 Motor above and including 1000KW shall be provided with three differential current transformers (PS class) mounted over the neutral leads within the enclosure. Loose three (3) numbers matching PS class CT shall be supplied for mounting on switchgear.

7.05.02 The arrangement shall be such as to permit easy access for C.T. testing and replacement. Current transformer characteristics shall match with the requirements of differential protection relay.

7.06.00 Accessory Terminal Box

7.06.01 All accessory equipment such as space heater, temperature detector, current transformers etc., shall be wired to and terminated in terminal boxes, separate from and independent of motor (power) terminal box.





7.06.02 Accessory terminal box shall be complete with double compression brass glands and pressure type terminals to suit required cable connections.

7.07.00 **Drain Plug**

Motor shall have drain plugs so located that they shall drain the water, resulting from the condensation or other causes from all pockets of the motor casing.

7.08.00 **Lifting Provisions**

Motor weighing 25 Kg. or more shall be provided with eyebolt or other adequate provision of lifting.

7.09.00 **Dowel Pins**

The motor shall be designed to permit easy access for drilling holes through motor feet or mounting flange for installation of dowel pins after assembling the motor and driven equipment.

7.10.00 **Painting**

Motor including fan shall be painted with corrosion proof paints.

8.00.00 TESTS

8.01.00 Upon completion, each motor shall be subject to standard routine tests as per IS. In addition, any special test called for in the driven equipment specification shall be performed.

8.02.00 Unless and otherwise stated, Six (6) copies of routine test certificates shall be submitted for approval prior to the dispatch of the motors from works.

8.03.00 The following type test reports shall be submitted for each type and rating of 11 kV & 3.3 kV motor:

- a) Degree of protection test for the enclosure followed by IR, HV and no load run test.
- b) Fault level withstand test for each type of terminal box.
- c) Lightning impulse withstand test on the sample coil as per IEC 60034, part-15.
- d) Surge withstand test on inter-turn insulation as per clause no. 5.1.2 of IEC 60034, part-15.

SPARES

Recommended spares for three (3) years operation shall be quoted along with the bid clearly identifying the part numbers with recommended quantities.





09.00.00 DRAWINGS, DATA & MANUALS

Drawings, data & manuals for the motors shall be submitted as indicated below:

09.01.00 Along with the bid

- a) List of the motors
- b) Individual motor data sheet as per format of the proposal data sheets.
- c) Scheme & write up on forced lubrication system, if any
- d) Type test report

09.02.00 After Award of the Contract

- a) Dimensional General Arrangement drawing
- b) Foundation Plan & Loading
- c) Cable end box details
- d) Space requirement for rotor removal
- e) Thermal withstand curves hot & cold
- f) Starting and speed torque characteristics at 80% & 100% voltage
- g) Complete motor data
- h) Erection & Maintenance Manual
- i) Efficiency curves.
- j) List of motors.
- k) Test reports





ANNEXURE – A

DESIGN DATA

1.0 SERVICE CONDITIONS

Refer Vol-IIA of Specification for FGD package.

2.0 AUXILIARY POWER SUPPLY

Supply	Description	Consumer
H.T. Supply	11000V, 3Ø, 3W, 50 Hz, non-effectively earthed. Fault level 40kA symm. for 3sec	Motors above 750kW
	3.3kV, 3Ø, 3W, 50 Hz, non-effectively earthed. Fault level 40kA symm for 3sec	Motors above 160kW up to & including 750kW
L.T. Supply	415V, 3Ø, 3W, 50 Hz, effectively earthed. Fault level 50kA symm for 1sec	Motors above 200W upto 160 kW
	240V, 1Ø, 2W, 50 Hz, effectively earthed.	Motors less than 200W, Lighting, space heating, A.C. control & protective devices
D.C. Supply	220V, 2W, unearthed. Fault level 25*kA for 1sec	D.C. alarm, control & protective devices

* Indicative only; actual value shall be decided by the Bidder, after substantiating the same by calculation.

3.0 RANGE OF VARIATION

A.C. Supply

Voltage: $\pm 10\%$ Frequency: $\pm 5\%$

Combined Volt & frequency: 10%(absolute sum)

D.C. Supply

Voltage: (+10% to -15%)





LV MOTORS

DATA SHEET-A

2X500 MW NTPL TUTICORIN FGD

SPECIFICATION NO.

VOLUME

II B

SECTION

D

REV. NO.

DATE: 20.02.2021

SHEET 1

OF 2

- 1.0 Design ambient temperature : 50 °C
- 2.0 Maximum acceptable kW rating of LV motor : 160KW *
- 3.0 Installation (Indoors/ Outdoors) : As required
- 4.0 Details of supply system
- a) Rated voltage (with variation) : 415V ± 10%
- b) Rated frequency (with variation) : 50 Hz + 5 % to - 5%
- c) Combined voltage & freq. variation : 10% (sum of absolute values)
- d) System fault level at rated voltage : 50 kA for 1 sec
- e) Short time rating for terminal boxes
- o Above 90 kW (Breaker Controlled) : 50 KA for 0.25 sec.
- o 90 kW & below (Contactor Controlled) : 50 KA protected by HRC fuse
- f) LV System grounding : Solidly
- 5.0 Winding & Insulation : Class F with temp rise limited to class B
- 6.0 Minimum voltage for starting : 80%
- 7.0 Power cables data : Shall be given during detailed engg.
- 8.0 Earth Conductor Size & Material : Shall be given during detailed engg.
- 9.0 Space heater supply (for motors >=30kw) : 240 V, 1φ, 50 Hz
- 10.0 Rating up to which Single phase motor : Acceptable below 0.2 kW
- 11.0 Locked rotor current
- a) Limit as percentage of FLC : As per IS 12615
- 12.0 Makes : BHEL/ Customer approval (Package owner to take care)
- 13.0 Paint shade : Blue (RAL 5012) – Corrosion proof
- 14.0 Degree Of protection for motor/ terminal box : Degree of protection for various enclosures as per IEC60034-05 shall be as follows:-
- i) Indoor motors - IP 23
- ii) Outdoor motors - IP 55
- iii) Cable box-indoor area - IP 23
- iv) Cable Box-Outdoor area - IP 55

*** LT motors of continuous duty shall be energy efficient IE3 class conforming to IS-12615**

15.0 TESTING REQUIREMENTS: IN LINE WITH SPECIFICATION

714945/2022/PS-PEM-MAX

	MOTORS	SPECIFICATION NO.
	DATA SHEET – C	VOLUME II B
	2X500 MW NTPL TUTICORIN FGD	SECTION D
		REV NO. 00 DATE 20.02.2021
		SHEET 1 OF 2

S. No.	Description	Data to be filled by successful bidder
A.	General	
1	Manufacturer & country of origin	
2	Motor type	
3	Type of starting	
4	Name of the equipment driven by motor & Quantity	
5	Maximum Power requirement of driven equipment	
6	Rated speed of Driven Equipment	
7	Design ambient temperature	
B.	Design and Performance Data	
1	Frame size & type designation	
2	Type of duty	
3	Rated Voltage	
4	Permissible variation for	
5	a) Voltage	
6	b) Frequency	
7	c) Combined voltage & frequency	
8	Rated output at design ambient temp (by resistance method)	
9	Synchronous speed & Rated slip	
10	Minimum permissible starting voltage	
11	Starting time in sec with mechanism coupled	
12	a) At rated voltage	
13	b) At min starting voltage	
14	Locked rotor current as percentage of FLC (including IS tolerance)	
15	Torque	
	a) Starting	
	b) Maximum	
16	Permissible temp rise at rated output over ambient temp & method	
17	Noise level at 1.0 m (dB)	
18	Amplitude of vibration	
19	Efficiency & P.F. at rated voltage & frequency	
	a) At 100% load	
	c) At 75% load	
	c) At starting	

NAME OF VENDOR			SEAL	REV.
NAME	SIGNATURE	DATE		

714945/2022/PS-PEM-MAX

	MOTORS	SPECIFICATION NO.
	DATA SHEET – C	VOLUME II B
	2X500 MW NTPL TUTICORIN FGD	SECTION D
		REV NO. 00 DATE 20.02.2021
		SHEET 2 OF 2

S. No.	Description	Data to be filled by successful bidder
C.	Constructional Features	
1	Method of connection of motor driven equipment	
2	Applicable Standard	
3	DOP of Enclosure	
4	Method of cooling	
5	Class of insulation	
6	Main terminal box	
	a) Type	
	b) Power Cable details (Conductor, size, armour/unarmour)	
	c) Cable Gland & lugs details (Size, type & material)	
	d) Permissible Fault level (kArms & duration in sec)	
7	Space heater details (Voltage & watts)	
8	Flame proof motor details (if applicable)	
	a) Enclosure	
	b) suitability for hazardous area	
	i Zone	O / I / II
	ii Group	IIA / IIB / IIC
9	No. of Stator winding	
10	Winding connection	
11	Kind of rotor winding	
12	Kind of bearings	
13	Direction of rotation when viewed from NDE	
14	Paint Shade & type	
15	Net weight of motor	
16	Outline mounting drawing No (To be enclosed as annexure)	
D.	Characteristic curves/ drawings (To be enclosed for motors of rating \geq 55KW)	
	a) Torque speed characteristic	
	b) Thermal withstand characteristic	
	c) Current vs time	
	d) Speed vs time	

NAME OF VENDOR			SEAL	REV.	
NAME	SIGNATURE	DATE			

714945/2022/PS-PEM-MAX:



GENERAL TECHNICAL REQUIREMENTS

FOR

LV MOTORS

SPECIFICATION NO.
PE-SS-999-506-E101

VOLUME NO. : II-B

SECTION : D

REV NO. : 00 DATE : 29/08/2005

SHEET : 1 OF 1

GENERAL TECHNICAL REQUIREMENTS

FOR

LV MOTORS

SPECIFICATION NO.: PE-SS-999-506-E101 Rev 00

	GENERAL TECHNICAL REQUIREMENTS FOR LV MOTORS	SPECIFICATION NO. PE-SS-999-506-E101
		VOLUME NO. : II-B
		SECTION : D
		REV NO. : 00 DATE : 29/08/2005
		SHEET : 1 OF 4

1.0 INTENT OF SPECIFICATION

The specification covers the design, materials, constructional features, manufacture, inspection and testing at manufacturer's work, and packing of Low voltage (LV) squirrel cage induction motors along with all accessories for driving auxiliaries in thermal power station.

Motors having a voltage rating of below 1000V are referred to as low voltage (LV) motors.

2.0 CODES AND STANDARDS

Motors shall fully comply with latest edition, including all amendments and revision, of following codes and standards:

IS:325	Three phase Induction motors
IS : 900	Code of practice for installation and maintenance of induction motors
IS: 996	Single phase small AC and universal motors
IS: 4722	Rotating Electrical machines
IS: 4691	Degree of Protection provided by enclosures for rotating electrical machines
IS: 4728	Terminal marking and direction of rotation rotating electrical machines
IS: 1231	Dimensions of three phase foot mounted induction motors
IS: 8789	Values of performance characteristics for three phase induction motors
IS: 13555	Guide for selection and application of 3-phase A.C. induction motors for different types of driven equipment
IS: 2148	Flame proof enclosures for electrical appliance
IS: 5571	Guide for selection of electrical equipment for hazardous areas
IS: 12824	Type of duty and classes of rating assigned
IS: 12802	Temperature rise measurement for rotating electrical machines
IS: 12065	Permissible limits of noise level for rotating electrical machines
IS: 12075	Mechanical vibration of rotating electrical machines

In case of imported motors, motors as per IEC-34 shall also be acceptable.

3.0 DESIGN REQUIREMENTS

3.1 Motors and accessories shall be designed to operate satisfactorily under conditions specified in data sheet-A and Project Information, including voltage & frequency variation of supply system as defined in Data sheet-A

3.2 Motors shall be continuously rated at the design ambient temperature specified in Data Sheet-A and other site conditions specified under Project Information
Motor ratings shall have at least a 15% margin over the continuous maximum demand of the driven equipment, under entire operating range including voltage & frequency variation specified above.

3.3 Starting Requirements

3.3.1 Motor characteristics such as speed, starting torque, break away torque and starting time shall be properly co-ordinated with the requirements of driven equipment. The accelerating torque at any speed with the minimum starting voltage shall be at least 10% higher than that of the driven equipment.

3.3.2 Motors shall be capable of starting and accelerating the load with direct on line starting without exceeding acceptable winding temperature.

	GENERAL TECHNICAL REQUIREMENTS FOR LV MOTORS	SPECIFICATION NO. PE-SS-999-506-E101
		VOLUME NO. : II-B
		SECTION : D
		REV NO. : 00 DATE : 29/08/2005
		SHEET : 2 OF 4

The limiting value of voltage at rated frequency under which a motor will successfully start and accelerate to rated speed with load shall be taken to be a constant value as per Data Sheet - A during the starting period of motors.

3.3.3 The following frequency of starts shall apply

- i) Two starts in succession with the motor being initially at a temperature not exceeding the rated load temperature.
- ii) Three equally spread starts in an hour the motor being initially at a temperature not exceeding the rated load operating temperature. (not to be repeated in the second successive hour)
- iii) Motors for coal conveyor and coal crusher application shall be suitable for three consecutive hot starts followed by one hour interval with maximum twenty starts per day and shall be suitable for minimum 20,000 starts during the life time of the motor

3.4 Running Requirements

3.4.1 Motors shall run satisfactorily at a supply voltage of 75% of rated voltage for 5 minutes with full load without injurious heating to the motor.

3.4.2 Motor shall not stall due to voltage dip in the system causing momentary drop in voltage upto 70% of the rated voltage for duration of 2 secs.

3.5 Stress During bus Transfer

3.5.1 Motors shall withstand the voltage, heavy inrush transient current, mechanical and torque stress developed due to the application of 150% of the rated voltage for at least 1 sec. caused due to vector difference between the motor residual voltage and the incoming supply voltage during occasional auto bus transfer.

3.5.2 Motor and driven equipment shafts shall be adequately sized to satisfactorily withstand transient torque under above condition.

3.6 Maximum noise level measured at distance of 1.0 metres from the outline of motor shall not exceed the values specified in IS 12065.

3.7 The max. vibration velocity or double amplitude of motors vibration as measured at motor bearings shall be within the limits specified in IS: 12075.

4.0 CONSTRUCTIONAL FEATURES

4.1 Indoor motors shall conform to degree of protection IP: 54 as per IS: 4691. Outdoor or semi-indoor motors shall conform to degree of protection IP: 55 as per IS: 4691 and shall be of weather-proof construction. Outdoor motors shall be installed under a suitable canopy

4.2 Motors upto 160KW shall have Totally Enclosed Fan Cooled (TEFC) enclosures, the method of cooling conforming to IC-0141 or IC-0151 of IS: 6362.

Motors rated above 160 KW shall be Closed Air Circuit Air (CACA) cooled

4.3 Motors shall be designed with cooling fans suitable for both directions of rotation.

	GENERAL TECHNICAL REQUIREMENTS FOR LV MOTORS	SPECIFICATION NO. PE-SS-999-506-E101
		VOLUME NO. : II-B
		SECTION : D
		REV NO. : 00 DATE : 29/08/2005
		SHEET : 3 OF 4
4.4.	Motors shall not be provided with any electric or pneumatic operated external fan for cooling the motors.	
4.5	Frames shall be designed to avoid collection of moisture and all enclosures shall be provided with facility for drainage at the lowest point.	
4.6	In case Class 'F' insulation is provided for LV motors, temperature rise shall be limited to the limits applicable to Class 'B' insulation. In case of continuous operation at extreme voltage limits the temperature limits specified in table-1 of IS:325 shall not exceed by more than 10°C.	
4.7	Terminals and Terminal Boxes	
4.7.1	Terminals, terminal leads, terminal boxes, windings tails and associated equipment shall be suitable for connection to a supply system having a short circuit level, specified in the Data Sheet-A. Unless otherwise stated in Data Sheet-A, motors of rating 110 kW and above will be controlled by circuit breaker and below 110 kW by switch fuse-contactor. The terminal box of motors shall be designed for the fault current mentioned in data sheet "A".	
4.7.2	unless otherwise specified or approved, phase terminal boxes of horizontal motors shall be positioned on the left hand side of the motor when viewed from the non-driving end.	
4.7.3	Connections shall be such that when the supply leads R, Y & B are connected to motor terminals A B & C or U, V & W respectively, motor shall rotate in an anticlockwise direction when viewed from the non-driving end. Where such motors require clockwise rotation, the supply leads R, Y, B will be connected to motor terminals A, C, B or U W & V respectively.	
4.7.4	Permanently attached diagram and instruction plate made preferably of stainless steel shall be mounted inside terminal box cover giving the connection diagram for the desired direction of rotation and reverse rotation.	
4.7.5	Motor terminals and terminal leads shall be fully insulated with no bar live parts. Adequate space shall be available inside the terminal box so that no difficulty is encountered for terminating the cable specified in Data Sheet-A.	
4.7.6	Degree of protection for terminal boxes shall be IP 55 as per IS 4691.	
4.7.7	Separate terminal boxes shall be provided for space heaters.. If this is not possible in case of LV motors, the space heater terminals shall be adequately segregated from the main terminals in the main terminal box. Detachable gland plates with double compression brass glands shall be provided in terminal boxes.	
4.7.8.	Phase terminal boxes shall be suitable for 360 degree of rotation in steps of 90 degree for LV motors.	
4.7.9	Cable glands and cable lugs as per cable sizes specified in Data Sheet-A shall be included. Cable lugs shall be of tinned Copper, crimping type.	
4.8	Two separate earthing terminals suitable for connecting G.I. or MS strip grounding conductor of size given in Data Sheet-A shall be provided on opposite sides of motor frame. Each terminal box shall have a grounding terminal.	
4.9	General	

714945/2022/PS-PEM-MAX:

	GENERAL TECHNICAL REQUIREMENTS FOR LV MOTORS	SPECIFICATION NO. PE-SS-999-506-E101
		VOLUME NO. : II-B
		SECTION : D
		REV NO. : 00 DATE : 29/08/2005
		SHEET : 4 OF 4
<p>4.9.1 Motors provided for similar drives shall be interchangeable.</p> <p>4.9.2 Suitable foundation bolts are to be supplied alongwith the motors.</p> <p>4.9.3 Motors shall be provided with eye bolts, or other means to facilitate safe lifting if the weight is 20Kgs. and above.</p> <p>4.9.4 Necessary fitments and accessories shall be provided on motors in accordance with the latest Indian Electricity rules 1956.</p> <p>4.9.5 All motors rated above 30 kW shall be provided with space heaters to maintain the motor internal air temperature above the dew point. Unless otherwise specified, space heaters shall be suitable for a supply of 240V AC, single phase, 50 Hz.</p> <p>4.9.6 Name plate with all particulars as per IS: 325 shall be provided</p> <p>4.9.7 Unless otherwise specified, the colour of finish shall be grey to Shade No. 631 and 632 as per IS:5 for motors installed indoor and outdoor respectively. The paint shall be epoxy based and shall be suitable for withstanding specified site conditions.</p> <p>5.0 INSPECTION AND TESTING</p> <p>5.1 All materials, components and equipments covered under this specification shall be procured, manufactured, as per the BHEL standard quality plan No. PED-506-00-Q-006/0 and PED-506-00-Q-007/2 enclosed with this specification and which shall be complied.</p> <p>5.2 LV motors of type-tested design shall be provided. Valid type test reports not more than 5 year shall be furnished. In the absence of these, type tests shall have to be conducted by manufacturer without any commercial implication to purchaser.</p> <p>5.3 All motors shall be subjected to routine tests as per IS: 325 and as per BHEL standard quality plan.</p> <p>5.4 Motors shall also be subjected to additional tests, if any, as mentioned in Data Sheet A.</p> <p>6.0 DRAWINGS TO BE SUBMITTED AFTER AWARD OF CONTRACT</p> <p>a) OGA drawing showing the position of terminal boxes, earthing connections etc.</p> <p>b) Arrangement drawing of terminal boxes.</p> <p>c) Characteristic curves: (To be given for motor above 55 kW unless otherwise specified in Data Sheet).</p> <p>i) Current vs. time at rated voltage and minimum starting voltage.</p> <p>ii) Speed vs. time at rated voltage and minimum starting voltage.</p> <p>iii) Torque vs. speed at rated voltage and minimum voltage. For the motors with solid coupling the above curves i), ii), iii) to be furnished for the motors coupled with driven equipment. In case motor is coupled with mechanical equipment by fluid coupling, the above curves shall be furnished with and without coupling.</p> <p>iv) Thermal withstand curve under hot and cold conditions at rated voltage and max. permissible voltage.</p>		

	MANUFACTURER/ BIDDER/ SUPPLIER NAME & ADDRESS	STANDARD QUALITY PLAN		SPEC. NO :	DATE:
		CUSTOMER :	QP NO.: PE-QP-999-Q-006, REV-02	DATE: 17.04.2020	
		PROJECT:	PO NO.:	DATE:	
		ITEM: AC ELECT. MOTORS UPTO 55KW (LV (415V))	SYSTEM:	SECTION: II	SHEET 1 of 2

S. NO.	COMPONENT & OPERATIONS	CHARACTERISTICS	CLASS	TYPE OF CHECK	QUANTUM OF CHECK		REFERENCE DOCUMENT	ACCEPTANCE NORMS	FORMAT OF RECORD	AGENCY				REMARKS
					M	C/ N				D	M	C	N	
1	2	3	4	5	6		7	8	9	*	**			
1.0	ASSEMBLY	1.WORKMANSHIP	MA	VISUAL	100%	-	MFG. SPEC.	MFG. SPEC.	LOG BOOK		P	-	-	
		2.DIMENSIONS	MA	VISUAL	100%	-	MFG. DRG./ MFG. SPEC.	MFG. DRG./ MFG. SPEC.	LOG BOOK		P	-	-	
		3.CORRECTNESS COMPLETENESS TERMINATIONS/ MARKING/ COLOUR CODE	MA	VISUAL	100%	-	MFG.SPEC./	MFG.SPEC.	LOG BOOK		P	-	-	
2.0	PAINTING	1.SHADE	MA	VISUAL	SAMPLE	-	MFG. SPEC/ APPROVED DATASHEET	MFG. SPEC/ APPROVED DATASHEET	LOG BOOK	✓	P	V	-	
3.0	TESTS	1.ROUTINE TEST INCLUDING SPECIAL TEST	MA	VISUAL	100%	-	IS-325 / IS-12615/ APPROVED DATA SHEET	IS-325 / IS-12615/ APPROVED DATA SHEET	TEST/ INSPN. REPORT	✓	P	V*	-	* NOTE -1
		2.OVERALL DIMENSIONS & ORIENTATION	MA	MEASUREME NT & VISUAL	100%	-	APPROVED DRG/ DATA SHEET	APPROVED DRG/ DATA SHEET	TEST/ INSPN. REPORT	✓	P	V*	-	* NOTE -1 & NOTE-2

BHEL					
ENGINEERING			QUALITY		
	Sign & Date	Name		Sign & Date	Name
Prepared by:	HEMA KUSHWAHA	HEMA KUSHWAHA	Checked by:		KUNAL GANDHI
Reviewed by:	PRAVEEN DUTTA	PRAVEEN DUTTA	Reviewed by:	RITESH KUMAR JAISWAL	RITESH KUMAR JAISWAL

BIDDER/ SUPPLIER	
Sign & Date	Seal

FOR CUSTOMER REVIEW & APPROVAL			
Doc No:	Sign & Date	Name	Seal
Reviewed by:			
Approved by:			

	MANUFACTURER/ SUPPLIER NAME & ADDRESS	BIDDER/	STANDARD QUALITY PLAN				SPEC. NO :				DATE:			
			CUSTOMER :				QP NO.: PE-QP-999-Q-006, REV-02				DATE: 17.04.2020			
			PROJECT:				PO NO.:				DATE:			
			ITEM: AC ELECT. MOTORS UPTO 55KW (LV (415V))		SYSTEM:		SECTION: II				SHEET 2 of 2			

		3.NAMEPLATE DETAILS	MA	VISUAL	100%	-	IS-325 / IS-12615 / APPROVED DATA SHEET	SAME AS COL. 7	TEST/ INSPN. REPORT	✓	P	V	-	
4.0	PACKING	SURFACE FINISH & COMPLETENESS	MA	VISUAL	100%	100%	AS PER MFG. STANDARD / (#)	AS PER MFG. STANDARD / (#).	INSPC. REPORT	✓	P	W	-	(#) REFER NOTE-8

NOTES:

1. Routine tests on 100% motors shall be done by the vendor. However, BHEL/ Customer shall witness routine tests on random samples. The sampling plan shall be mutually agreed upon.
2. For exhaust/ventilation fan motors of rating up to 1.5 KW, only routine test certificates shall be furnished for scrutiny.
3. In case test certificates for these tests on similar type, size and design of motor from independent laboratory are available, the same is valid for 5 years.
4. BHEL reserves the right to perform repeat test, if required.
5. After packing and prior to issue MDCC, photographs of items to be despatched shall be sent to BHEL for review.
6. In case of any changes in QP commented by customer at contract stage, same shall be carried out by bidder without any implication to BHEL/ Customer.
7. Project specific QP to be developed based on customer requirement.
8. For export job, BHEL technical specification for seaworthy packing to be followed.
9. Packing shall be suitable for storage at site in tropical climate conditions.
10. Latest revision/ year of issue of all the standards (IS/ ASME/ IEC etc.) indicated in QP shall be referred.

LEGENDS:

*RECORDS, IDENTIFIED WITH "TICK"(✓) SHALL BE ESSENTIALLY INCLUDED BY SUPPLIER IN QA DOCUMENTATION,

** **M:** SUPPLIER/ MANUFACTURER/ SUB-SUPPLIER, **B:** MAIN SUPPLIER/ BHEL/ THIRD PARTY INSPECTION AGENCY, **C:** CUSTOMER,

P: PERFORM, **W:** WITNESS, **V:** VERIFICATION, AS APPROPRIATE



MA: MAJOR, **MI:** MINOR, **CR:** CRITICAL

D: DOCUMENTATION

BHEL				BIDDER/ SUPPLIER		FOR CUSTOMER REVIEW & APPROVAL			
ENGINEERING		QUALITY		Sign & Date		Doc No:			
Sign & Date	Name	Sign & Date	Name	Seal		Sign & Date	Name	Seal	
Prepared by:	HEMA KUSHWAHA	Checked by:	KUNAL GANDHI			Reviewed by:			
Reviewed by:	PRAVEEN DUTTA	Reviewed by:	RITESH KUMAR JAISWAL			Approved by:			

	MANUFACTURER/ BIDDER/ SUPPLIER NAME & ADDRESS	STANDARD QUALITY PLAN		SPEC. NO. :	
		CUSTOMER :		QP NO.: PE-QP-999-Q-007, REV-04	
		PROJECT:		PO NO.:	
		ITEM: AC ELECT. MOTORS 55 KW & ABOVE (LV (415V))		SYSTEM:	
		SECTION: II		DATE:17.04.2020	
				SHEET 1 OF 9	

Sl No.	Component & Operations	Characteristics	Class	Type of Check	Quantum Of check		Reference Document	Acceptance NORMS	FORMAT OF RECORD	AGENCY		
					M	C/N				D	M	C
1.0	RAW MATERIAL & BOUGHT OUT CONTROL											
1.1	SHEET STEEL, PLATES, SECTION, EYEBOLTS	1.SURFACE CONDITION	MA	VISUAL	100%	-	-	FREE FROM BLINKS, CRACKS, WAVINESS ETC	LOG BOOK	P	-	-
		2.DIMENSIONS	MA	MEASUREMENT	SAMPLE	-	MANUFACTURER'S DRG./SPEC	MANUFACTURER'S DRG./SPEC	LOG BOOK	P	-	-
		3.PROOF LOAD TEST (EYE BOLT)	MA	MECH. TEST	SAMPLE	-	MANUFACTURER'S DRG./SPEC	MANUFACTURER'S DRG./SPEC	TEST REPORT	P/V	-	-
1.2	HARDWARES	1.SURFACE CONDITION	MA	VISUAL	100%	-	-	FREE FROM CRACKS, UN-EVENNESS ETC.	TEST REPORT	P	-	-
		2.PROPERTY CLASS	MA	VISUAL	SAMPLES	-	MANUFACTURER'S DRG./SPEC	MANUFACTURER'S DRG./SPEC	TC	P/V	-	-
1.3	CASTING	1.SURFACE CONDITION	MA	VISUAL	100%	-	MANUFACTURER'S DRG./SPEC	FREE FROM CRACKS, BLOW HOLES ETC.	LOG BOOK	P/V	-	-
		2.CHEM. & PHY. PROP.	MA	CHEM & MECH TEST	1/HEAT NO.	-	MANUFACTURER'S DRG./SPEC	MANUFACTURER'S DRG./SPEC	TC	P/V	-	-
		3.DIMENSIONS	MA	MEASUREMENT	100%	-	MANUFACTURER'S DRG.	MANUFACTURER'S DRG.	LOG BOOK	P/V	-	-
1.4	PAINT & VARNISH	1.MAKE, SHADE, SHELF LIFE & TYPE	MA	VISUAL	100%	CONTINUOUS	MANUFACTURER'S DRG./SPEC	MANUFACTURER'S DRG./SPEC	LOG BOOK	P/V	-	-

BHEL					
ENGINEERING			QUALITY		
Sign & Date	Name		Sign & Date	Name	
Prepared by: HEMA KUSHWAHA	HEMA KHUSHWAHA	Checked by: 		KUNAL GANDHI	
Reviewed by: PRAVEEN DUTTA	PRAVEEN DUTTA	Reviewed by: RITESH KUMAR		R K JAISWAL	

BIDDER/ SUPPLIER	
Sign & Date	
Seal	

FOR CUSTOMER REVIEW & APPROVAL			
Doc No:			
	Sign & Date	Name	Seal
Reviewed by:			
Approved by:			

	MANUFACTURER/ BIDDER/ SUPPLIER NAME & ADDRESS	STANDARD QUALITY PLAN		SPEC. NO :		DATE:17.04.2020 SHEET 2 OF 9
		CUSTOMER :		QP NO.: PE-QP-999-Q-007, REV-04		
		PROJECT:		PO NO.:		
		ITEM: AC ELECT. MOTORS 55 KW & ABOVE (LV (415V))		SYSTEM:		

SI No.	Component & Operations	Characteristics	Class	Type of Check	Quantum Of check		Reference Document	Acceptance NORMS	FORMAT OF RECORD	AGENCY				
					M	C/N				D	M	C	N	
1.5	SHAFT (FORGED OR ROLLED)	1. SURFACE COND.	MA	VISUAL	100%	-	-	FREE FROM VISUAL DEFECTS	LOG BOOK		P	-	-	VENDOR'S APPROVAL IDENTIFICATION SHALL BE MAINTAINED
		2. CHEM. & PHYSICAL PROPERTIES	MA	CHEM. & PHYSICAL TESTS	1/HEAT NO. OR HEAT TREATMENT BATCH NO	-	MANUFACTURER'S DRG./ SPEC.	MANUFACTURER'S DRG./ STD.	TC		P/W	-	-	
		3. DIMENSIONS	MA	MEASUREMENT	100%	-	MANUFACTURER'S DRG./ SPEC.	MANUFACTURER'S DRG.	LOG BOOK		P/W	-	-	
		4. INTERNAL FLAWS	CR	ULTRASONIC TEST	100%	-	ASTM-A388	MANUFACTURER'S STD.	INSPECTION REPORT	✓	P/W	V	-	FOR DIA OF 55 MM & ABOVE
1.6	SPACE HEATERS, CONNECTORS, TERMINAL BLOCKS, CABLES, CABLE LUGS, CARBON BRUSH TEMP. DETECTORS, RTD, BTD'S	1. MAKE & RATING	MA	VISUAL	100%	-	MANUFACTURER'S DRG./STD.	MANUFACTURER'S DRG./STD.	INSPECTION REPORT		P/W	-	-	
		2. PHYSICAL COND.	MA	VISUAL	100%	-	MANUFACTURER'S DRG./STD.	NO PHYS. DAMAGE, NO ELECTRICAL DISCONTINUITY	INSPECTION REPORT		P/W	-	-	
		3. DIMENSIONS (WHEREVER APPLICABLE)	MA	MEASUREMENT	SAMPLE	-	MANUFACTURER'S DRG./ STD	MANUFACTURER'S DRG. / STD.	INSPECTION REPORT		P/W	-	-	
		4. PERFORMANCE/ CALIBRATION	MA	TEST	100%	-	MANUFACTURER'S DRG./ STD	MANUFACTURER'S DRG. / STD.	TEST REPORT		P/W	-	-	

BHEL					
ENGINEERING			QUALITY		
	Sign & Date	Name		Sign & Date	Name
Prepared by:	HEMA KUSHWAHA	HEMA KHUSHWAHA	Checked by:		KUNAL GANDHI
Reviewed by:	PRAVEEN DUTTA	PRAVEEN DUTTA	Reviewed by:	RITESH KUMAR JAISWAL	R K JAISWAL

BIDDER/ SUPPLIER	
Sign & Date	
Seal	

FOR CUSTOMER REVIEW & APPROVAL			
Doc No:			
	Sign & Date	Name	Seal
Reviewed by:			
Approved by:			

	MANUFACTURER/ BIDDER/ SUPPLIER NAME & ADDRESS	STANDARD QUALITY PLAN		SPEC. NO :		
		CUSTOMER :		QP NO.: PE-QP-999-Q-007, REV-04		DATE:17.04.2020
		PROJECT:		PO NO.:		
		ITEM: AC ELECT. MOTORS 55 KW & ABOVE (LV (415V))		SYSTEM:		SECTION: II

Sl No.	Component & Operations	Characteristics	Class	Type of Check	Quantum Of check		Reference Document	Acceptance NORMS	FORMAT OF RECORD	AGENCY					
					6	7				8	9	10	11	12	13
1.7	OTHER INSULATING MATERIALS LIKE SLEEVES, BINDINGS CORDS, PAPERS, PRESS BOARDS ETC.	1. SURFACE COND. ETC.	MA	VISUAL	100%	-	-	NO VISUAL DEFECTS	TEST REPORT		P/V	-	-		
		2.DIMENSION(BORE DIA, WALL THICKNESS, BDV AS RECEIVED, BDV AFTER FOLDING AT 180°	MA	TEST	SAMPLE	-	MANUFACTURER'S STD.	MANUFACTURER'S STD.	LOG BOOK AND OR SUPPLIER'S TC		P/V	-	-		
1.8	SHEET STAMPING (PUNCHED)	1. SURFACE COND.	MA	VISUAL	100%	-	-	NO VISUAL DEFECTS (FREE FROM BURS)	LOG BOOK		P	-	-		
		2.DIMENSIONS INCLUDING BURS HEIGHT	MA	MEASUREMENT	SAMPLE	-	MANUFACTURER'S DRG.	MANUFACTURER'S DRG.	LOG BOOK		P/V	-	-		
		3. ACCEPTANCE TESTS	MA	ELECT. & MECH TESTS	SAMPLE	-	MANUFACTURER'S DRG./ STD.	MANUFACTURER'S DRG./ STD.	TC		P/V	-	-		
1.9	CONDUCTORS	1. SURFACE FINISH	MA	VISUAL	100%	-	-	FREE FROM VISUAL DEFECTS	LOG BOOK		*P/V	-	-	* MOTOR MANUFACTURER TO CONDUCT VISUAL CHECK FOR SURFACE FINISH ON RANDOM BASIS (10% SAMPLE) AT HIS WORKS AND MAINTAIN RECORD FOR VERIFICATION BY	
		2.ELECT. PROP. & MECH. PROP	MA	ELECT. & MECH.TEST	SAMPLES	-	MANUFACTURER'S DRG./ SPEC.	MANUFACTURER'S / SPEC.	TC & VENDOR'S TEST REPORTS		P/V	-	-		





BHEL					
ENGINEERING			QUALITY		
	Sign & Date	Name		Sign & Date	Name
Prepared by:	HEMA KUSHWAHA	HEMA KHUSHWAHA	Checked by:		KUNAL GANDHI
Reviewed by:	PRAVEEN DUTTA	PRAVEEN DUTTA	Reviewed by:	RITESH JAIN	R K JAISWAL

BIDDER/ SUPPLIER	
Sign & Date	
Seal	

FOR CUSTOMER REVIEW & APPROVAL			
Doc No:			
	Sign & Date	Name	Seal
Reviewed by:			
Approved by:			

	MANUFACTURER/ BIDDER/ SUPPLIER NAME & ADDRESS	STANDARD QUALITY PLAN		SPEC. NO :		DATE:17.04.2020 SHEET 4 OF 9
		CUSTOMER :		QP NO.: PE-QP-999-Q-007, REV-04		
		PROJECT:		PO NO.:		
		ITEM: AC ELECT. MOTORS 55 KW & ABOVE (LV (415V))	SYSTEM:	SECTION: II		

SI No.	Component & Operations	Characteristics	Class	Type of Check	Quantum Of check		Reference Document	Acceptance NORMS	FORMAT OF RECORD	AGENCY					
					6	C/N				8	9	D	M	C	N
1.10	BEARINGS	3.DIMENSIONS 1.MAKE & TYPE 2.DIMENSIONS	MA MA MA	MEASUREMENT VISUAL MEASUREMENT	SAMPLES 100% SAMPLE	- - -	MANUFACTURER'S DRG/ SPEC. MANUFACTURER'S DRG/ APPROVED DATASHEET APPROVED DATASHEET	MANUFACTURER'S / SPEC. MANUFACTURER'S DRG./ APPROVED DATASHEET APPROVED DATASHEET/ BEARING MANUF'S CATALOGUES	LOG BOOK LOG BOOK LOG BOOK	P/V P/V P/V	- - -	- - -			
1.11	SLIP RING (WHEREVER APPLICABLE)	1.SURFACE COND. 2.DIMENSIONS 3.TEMP.WITH- STAND CAPACITY	MA MA MA	VISUAL MEASUREMENT ELECT.TEST	100% SAMPLE SAMPLE	- - -	- MANUFACTURER'S DRG MANUFACTURER'S STD./ APPROVED DATASHEET	FREE FROM VISUAL DEFECTS MANUFACTURER'S DRG MANUFACTURER'S STD./ APPROVED DATASHEET	LOG BOOK LOG BOOK LOG BOOK	P P P/V	- - -	- - -			
1.12	OIL SEALS & GASKETS	1.MATERIAL OF GASKET 2.SURFACE COND. 3.DIMENSIONS	MA MA MA	VISUAL VISUAL MEASUREMENT	100% 100% SAMPLE	- - -	MANUFACTURER'S DRG/SPECS - MANUFACTURER'S DRG	MANUFACTURER'S DRG./ SPECS, FREE FROM VISUAL DEFECTS MANUFACTURER'S DRG	LOG BOOK LOG BOOK LOG BOOK	P P P	- - -	- - -			



BHEL					
ENGINEERING			QUALITY		
	Sign & Date	Name		Sign & Date	Name
Prepared by:	 HEMA KUSHWAHA	HEMA KHUSHWAHA	Checked by:	 KUNAL GANDHI	KUNAL GANDHI
Reviewed by:	 PRAVEEN DUTTA	PRAVEEN DUTTA	Reviewed by:	 R K JAISWAL	R K JAISWAL

BIDDER/ SUPPLIER	
Sign & Date	
Seal	

FOR CUSTOMER REVIEW & APPROVAL			
Doc No:			
	Sign & Date	Name	Seal
Reviewed by:			
Approved by:			

	MANUFACTURER/ BIDDER/ SUPPLIER NAME & ADDRESS	STANDARD QUALITY PLAN		SPEC. NO.:		
		CUSTOMER :		QP NO.: PE-QP-999-Q-007, REV-04		DATE: 17.04.2020
		PROJECT:		PO NO.:		
		ITEM: AC ELECT. MOTORS 55 KW & ABOVE (LV (415V))		SYSTEM:	SECTION: II	SHEET 5 OF 9

Sl No.	Component & Operations	Characteristics	Class	Type of Check	Quantum Of check		Reference Document	Acceptance NORMS	FORMAT OF RECORD		AGENCY							
					M	C/N			9	*	**	D	M	C	N			
2.0	IN PROCESS																	
2.1	STATOR FRAME WELDING (IN CASE OF FABRICATED STATOR)	1.WORKMANSHIP & CLEANNESS	MA	VISUAL	100%	-	MANUFACTURER'S DRG	GOOD FINISH	LOG BOOK			PW	-	-				
		2.DIMENSIONS	MA	MEASUREMENT	100%	-	MANUFACTURER'S DRG	MANUFACTURER'S DRG	LOG BOOK			P	-	-				
2.2	MACHINING	1.FINISH	MA	VISUAL	100%	-	-DC-	GOOD FINISH	LOG BOOK			P	-	-				
		2.DIMENSIONS	MA	MEASUREMENT	100%	-	MANUFACTURER'S DRG	MANUFACTURER'S DRG	LOG BOOK			P	-	-				
		3.SHAFT SURFACE FLOWS	MA	PT	100%	-	MANUFACTURER'S STD./ASTM-E165	MANUFACTURER'S STD./APPROVED DATASHEET.	LOG BOOK	✓		P	V	-				
2.3	PAINING	1.SURFACE PREPARATION	MA	VISUAL	100%	-	MANUFACTURER'S STD./APPROVED DATASHEET	MANUFACTURER'S STD./APPROVED DATASHEET	LOG BOOK			P	-	-				
		2.PAINT THICKNESS (BOTH PRIMER & FINISH COAT)	MA	MEASUREMENT BY ELCOMETER	SAMPLE	-	MANUFACTURER'S STD./APPROVED DATASHEET	MANUFACTURER'S STD./APPROVED DATASHEET	LOG BOOK			P	-	-				
		3.SHADE	MA	VISUAL	SAMPLE	-	MANUFACTURER'S STD./APPROVED DATASHEET	MANUFACTURER'S STD./APPROVED DATASHEET	LOG BOOK			P	-	-				
		4.ADHESION	MA	CROSS CUTTING & TAPE TEST	SAMPLE	-	MANUFACTURER'S STD./APPROVED DATASHEET	MANUFACTURER'S STD./APPROVED DATASHEET	LOG BOOK			P	-	-				



BHEL					
ENGINEERING			QUALITY		
	Sign & Date	Name		Sign & Date	Name
Prepared by:	HEMA KUSHWAHA	HEMA KHUSHWAHA	Checked by:		KUNAL GANDHI
Reviewed by:		PRAVEEN DUTTA	Reviewed by:		R K JAISWAL

BIDDER/ SUPPLIER	
Sign & Date	
Seal	

FOR CUSTOMER REVIEW & APPROVAL			
Doc No:			
	Sign & Date	Name	Seal
Reviewed by:			
Approved by:			

	MANUFACTURER/ BIDDER/ SUPPLIER NAME & ADDRESS	STANDARD QUALITY PLAN		SPEC. NO.:		
		CUSTOMER :		QP NO.: PE-QP-999-Q-007, REV-04		DATE: 17.04.2020
		PROJECT:		PO NO.:		
		ITEM: AC ELECT. MOTORS 55 KW & ABOVE (LV (415V))		SYSTEM:	SECTION: II	SHEET 6 OF 9

Sl No.	Component & Operations	Characteristics	Class	Type of Check	Quantum Of check		Reference Document	Acceptance NORMS	FORMAT OF RECORD		AGENCY			
					M	C/N			9	.	**	D	M	C
2.4	SHEET STACKING	1.COMPLETENESS	MA	MEASUREMENT	SAMPLE	-	MANUFACTURER'S STD.	MANUFACTURER'S STD.	LOG BOOK		P	-	-	
		2.COMPRESSION & TIGHTENING	MA	MEASUREMENT	100%	-	MANUFACTURER'S STD.	MANUFACTURER'S STD.	LOG BOOK		P	-	-	
2.5	WINDING	1.COMPLETENESS	CR	VISUAL	100%	-	MANUFACTURER'S STD./APPROVED DATASHEET	MANUFACTURER'S STD./APPROVED DATASHEET	LOG BOOK		P	-	-	
		2.CLEANLINESS	CR	VISUAL	100%	-	MANUFACTURER'S STD./APPROVED DATASHEET	MANUFACTURER'S STD./APPROVED DATASHEET	LOG BOOK		P	-	-	
		3.IR-HV-IR	CR	ELECT. TEST	100%	-	IS-325/IS-12615/IEC-60034 PART-1	IS-325/IS-12615/IEC-60034 PART-1	TEST/INSPC. REPORT	✓	P	V	-	
		4.RESISTANCE	CR	ELECT. TEST	100%	-	IS-325/IS-12615/IEC-60034 PART-1	IS-325/IS-12615/IEC-60034 PART-1	TEST/INSPC. REPORT	✓	P	V	-	
		5.INTERTURN INSULATION	CR	ELECT. TEST	100%	-	IS-325/IS-12615/IEC-60034 PART-1	IS-325/IS-12615/IEC-60034 PART-1	TEST/INSPC. REPORT		P	-	-	
2.6	IMPREGNATION	1.VISCOSITY	MA	PHY. TEST	AT STARTING	-	MANUFACTURER'S STANDARD	MANUFACTURER'S STANDARD	LOG BOOK		P	-	-	
		2.TEMP. PRESSURE VACCUM	MA	PROCESS CHECK	CONTINUOUS	-	MANUFACTURER'S STANDARD	MANUFACTURER'S STANDARD	LOG BOOK		P	-	-	
		3.NO. OF DIPS	MA	PROCESS CHECK	CONTINUOUS	-	MANUFACTURER'S STANDARD	MANUFACTURER'S STANDARD	LOG BOOK	✓	P	V	-	THREE DIPS TO BE GIVEN



BHEL					
ENGINEERING			QUALITY		
Sign & Date	Name		Sign & Date	Name	
Prepared by: HEMA KUSHWAHA	HEMA KHUSHWAHA	Checked by: 		KUNAL GANDHI	
Reviewed by: PRAVEEN DUTTA	PRAVEEN DUTTA	Reviewed by: 		R K JAISWAL	

BIDDER/ SUPPLIER	
Sign & Date	
Seal	

FOR CUSTOMER REVIEW & APPROVAL			
Doc No:			
	Sign & Date	Name	Seal
Reviewed by:			
Approved by:			

	MANUFACTURER/ BIDDER/ SUPPLIER NAME & ADDRESS	STANDARD QUALITY PLAN		SPEC. NO. :		DATE:17.04.2020
		CUSTOMER :		QP NO.: PE-QP-899-Q-007, REV-04		
		PROJECT:		PO NO.:		
		ITEM: AC ELECT, MOTORS 55 KW & ABOVE (LV (415V))	SYSTEM:	SECTION: II	SHEET 7 OF 9	

Sl No.	Component & Operations	Characteristics	Class	Type of Check	Quantum Of check		Reference Document	Acceptance NORMS	FORMAT OF RECORD	AGENCY			
					M	C/N					*	**	D
2.7	COMPLETE STATOR ASSEMBLY	4.DURATION 1.COMPACTNESS & CLEANLINESS	MA MA	PROCESS CHECK VISUAL	CONTINUOUS 100%	- -	MANUFACTURER'S STANDARD MANUFACTURER'S STANDARD	MANUFACTURER'S STANDARD MANUFACTURER'S STANDARD	LOG BOOK LOG BOOK	✓ -	P P	V -	- -
2.8	BRAZING/COMPRESSION JOINT	1.COMPLETENESS 2.SOUNDNESS	CR CR	VISUAL MALLETT TEST & UT	100% 100%	- -	MANUFACTURER'S STANDARD MANUFACTURER'S STANDARD	MANUFACTURER'S STANDARD MANUFACTURER'S STANDARD	LOG BOOK TEST/INSPC. REPORT	- ✓	P P	- V	- -
2.9	COMPLETE ROTOR ASSEMBLY	3.HV 1.RESIDUAL UNBALANCE	MA CR	ELECT. TEST DYN. BALANCE	100% 100%	- -	MANUFACTURER'S STANDARD MANUFACTURER'S SPEC./ ISO 1940	MANUFACTURER'S STANDARD MANUFACTURER'S DWG.	TEST/INSPC. REPORT LOG BOOK	✓ -	P P	V -	- -
2.10	ASSEMBLY	2.SOUNDNESS OF DIE CASTING	CR	ELECT. (GROWLER TEST)	100%	-	MANUFACTURER'S SPEC.	MANUFACTURER'S SPEC.	TEST/INSPC. REPORT	✓	P	V	-
		1.ALIGNMENT	MA	MEAS.	100%	-	MANUFACTURER'S SPEC.	MANUFACTURER'S SPEC.	LOG BOOK	-	P	-	-
		2.WORKMANSHIP	MA	VISUAL	100%	-	MANUFACTURER'S SPEC.	MANUFACTURER'S SPEC.	LOG BOOK	-	P	-	-
		3.AXIAL PLAY	MA	MEAS.	100%	-	MANUFACTURER'S SPEC.	MANUFACTURER'S SPEC.	LOG BOOK	✓	P	V	-
		4.DIMENSIONS	MA	MEAS.	100%	-	MANUFACTURER'S DRG./ MANUFACTURER'S SPEC.	MANUFACTURER'S DRG./ MANUFACTURER'S SPEC.	LOG BOOK	-	P	-	-
		5.CORRECTNESS, COMPLETENESS TERMINATIONS/ MARKING/ COLOUR CODE	MA	VISUAL	100%	-	MANUFACTURER'S SPEC.	MANUFACTURER'S SPEC.	LOG BOOK	-	P	-	-
		6. RTD, BTD & SPACE HEATER MOUNTING.	MA	VISUAL	100%	-	MANUFACTURER'S SPEC.	MANUFACTURER'S SPEC.	LOG BOOK	✓	P	V	-



BHEL					
ENGINEERING			QUALITY		
	Sign & Date	Name		Sign & Date	Name
Prepared by:	HEMA KUSHWAHA	HEMA KHUSHWAHA	Checked by:		KUNAL GANDHI
Reviewed by:		PRAVEEN DUTTA	Reviewed by:		R K JAISWAL

BIDDER/ SUPPLIER	
Sign & Date	
Seal	

FOR CUSTOMER REVIEW & APPROVAL			
Doc No:			
	Sign & Date	Name	Seal
Reviewed by:			
Approved by:			

	MANUFACTURER/ BIDDER/ SUPPLIER NAME & ADDRESS	STANDARD QUALITY PLAN		SPEC. NO :		
		CUSTOMER :		QP NO.: PE-QP-999-Q-007, REV-04		DATE:17,04,2020
		PROJECT:		PO NO.:		
		ITEM: AC ELECT. MOTORS 55 KW & ABOVE (LV (415V))		SYSTEM:	SECTION: II	SHEET 8 OF 9

SI No.	Component & Operations	Characteristics	Class	Type of Check	Quantum Of check		Reference Document	Acceptance NORMS	FORMAT OF RECORD	AGENCY				
					M	C/N				D	M	C	N	
3.0	TESTS	1.TYPE TESTS INCLUDING SPECIAL TESTS	MA	ELECT.TEST	1/TYPE/SIZE	1/TYPE/SIZE	IS-325/IS-12615/APPROVED DATASHEET	IS-325/IS-12615/APPROVED DATASHEET	TEST REPORT	✓	P	W*	-	* NOTE - 1
		2.ROUTINE TESTS INCLUDING SPECIAL TEST	MA	ELECT.TEST	100%	-	IS-325/IS-12615/APPROVED DATASHEET	IS-325/IS-12615/APPROVED DATASHEET	TEST REPORT	✓	P	√ [§]	-	§ NOTE - 2
		3.VIBRATION & NOISE LEVEL	MA	ELECT.TEST	100%	-	IS: 12075 / IEC 60034-14 & IS-12065	IS: 12075 / IEC 60034-14 & IS-12065	TEST REPORT	✓	P	√ [§]	-	§ NOTE - 2
		4.OVERALL DIMENSIONS AND ORIENTATION	MA	MEASUREMENT & VISUAL	100%	100%	APPROVED DRG/DATA SHEET	APPROVED DRG/DATA SHEET &	TEST/INSPC. REPORT	✓	P	W	-	
		5.DEGREE OF PROTECTION	MA	ELECT. & MECH. TEST	1/TYPE/ SIZE	-	IEC 60034-5/IS-12615	APPROVED DATASHEET	TC	✓	P	V	-	TC FROM AN INDEPENDENT LABORATORY, REFER NOTE-3
		6. MEASUREMENT OF RESISTANCE OF RTD & BTD	MA	ELECT. & MECH. TEST	100%	-	IS-325/IS-12615/IEC-60034 PART-1/IS: 12802	IS-325/IS-12615/IEC-60034 PART-1/IS: 12802	TC	✓	P	√ [§]	-	§ NOTE - 2
		7. MEASUREMENT OF RESISTANCE, IR OF SPACE HEATER	MA	ELECT. & MECH. TEST	100%	-	IS-325/IS-12615/IEC-60034 PART-1	IS-325/IS-12615/IEC-60034 PART-1	TC	✓	P	√ [§]	-	§ NOTE - 2
		8. NAME PLATE DETAILS	MA	VISUAL	100%	-	IS-325/IS-12615& DATA SHEET	IS-325/IS-12615 & DATA SHEET	TEST/INSPC. REPORT	✓	P	√ [§]	-	§ NOTE - 2
		9.EXPLOSION FLAME PROOF NESS (IF SPECIFIED)	MA	EXPLOSION FLAME PROOF TEST	1/TYPE	-	IS 2148 / IEC 60079-1	IS 2148 / IEC 60079-1	TC	✓	P	V	-	TC FROM AN INDEPENDENT LABORATORY, REFER NOTE-3
		10. PAINT SHADE, THICKNESS & FINISH	MA	VISUAL & MEASUREMENT BY ELKOMETER	SAMPLE	SAMPLE	APPROVED DATASHEET	APPROVED DATASHEET	TC	✓	P	W [§]	-	SAMPLING PLAN TO BE DECIDED BY INSPECTION AGENCY § NOTE - 2

BHEL					
ENGINEERING			QUALITY		
	Sign & Date	Name		Sign & Date	Name
Prepared by:	HEMA KUSHWAHA	HEMA KHUSHWAHA	Checked by:		KUNAL GANDHI
Reviewed by:		PRAVEEN DUTTA	Reviewed by:		R K JAISWAL

BIDDER/ SUPPLIER	
Sign & Date	
Seal	

FOR CUSTOMER REVIEW & APPROVAL			
Doc No:			
	Sign & Date	Name	Seal
Reviewed by:			
Approved by:			

	MANUFACTURER/ BIDDER/ SUPPLIER NAME & ADDRESS	STANDARD QUALITY PLAN		SPEC. NO :		DATE:17.04.2020 SHEET 9 OF 9
		CUSTOMER :		QP NO.: PE-QP-999-Q-007, REV-04		
		PROJECT:		PO NO.:		
		ITEM: AC ELECT. MOTORS 55 KW & ABOVE (LV (415V))	SYSTEM:	SECTION: II		

Sl No.	Component & Operations	Characteristics	Class	Type of Check	Quantum Of check		Reference Document	Acceptance NORMS	FORMAT OF RECORD	AGENCY				
1	2	3	4	5	6		7	8	9	**				
					M	C/N				D	M	C	N	
4.0	PACKING	SURFACE FINISH & COMPLETENESS	MA	VISUAL	100%	100%	AS PER MANUFACT. STANDARD / (#)	AS PER MANUFACT. STANDARD / (#)	INSPC. REPORT	✓	P	W	-	(#): REFER NOTE-8

NOTES:

- 1 DEPENDING UPON THE SIZE AND CRITICALLY, WITNESSING BY BHEL SHALL BE DECIDED.
- 2 ROUTINE TESTS ON 100% MOTORS SHALL BE DONE BY THE VENDOR, HOWEVER, BHEL/CUSTOMER SHALL WITNESS ROUTINE TESTS ON RANDOM SAMPLES, THE SAMPLING PLAN SHALL BE MUTUALLY AGREED UPON.
- 3 IN CASE TEST CERTIFICATES FOR THESE TESTS ON SIMILAR TYPE, SIZE AND DESIGN OF MOTOR FROM INDEPENDENT LABORATORY ARE AVAILABLE, THE SAME IS VALID FOR 5 YEARS.
- 4 BHEL RESERVES THE RIGHT TO PERFORM REPEAT TEST, IF REQUIRED.
- 5 AFTER PACKING AND PRIOR TO ISSUE MDCC, PHOTOGRAPHS OF ITEMS TO BE DESPATCHED SHALL BE SENT TO BHEL PURCHASE GROUP FOR REVIEW.
- 6 IN CASE , ANY CHANGES IN QP COMMENTED BY CUSTOMER AT CONTRACT STAGE SHALL BE CARRIED OUT BY BIDDER WITHOUT ANY IMPLICATION TO BHEL/ CUSTOMER.
- 7 PROJECT SPECIFIC QP TO BE DEVELOPED BASED ON CUSTOMER REQUIREMENT.
- 8 FOR EXPORT JOB, BHEL TECHNICAL SPECIFICATION FOR SEAWORTHY PACKING TO BE FOLLOWED.
- 9 PACKING SHALL BE SUITABLE FOR STORAGE AT SITE IN TROPICAL CLIMATE CONDITIONS.
- 10 LATEST REVISION/ YEAR OF ISSUE OF ALL THE STANDARDS (IS/ ASME/ IEC ETC.) INDICATED IN QP SHALL BE REFERRED.

LEGENDS:

*RECORDS, IDENTIFIED WITH "TICK"(✓) SHALL BE ESSENTIALLY INCLUDED BY SUPPLIER IN QA DOCUMENTATION.
 ** M: SUPPLIER/ MANUFACTURER/ SUB-SUPPLIER, B: MAIN SUPPLIER/ BHEL/ THIRD PARTY INSPECTION AGENCY, C: CUSTOMER,
 P: PERFORM, W: WITNESS, V: VERIFICATION, AS APPROPRIATE
 MA: MAJOR, MI: MINOR, CR: CRITICAL
 D: DOCUMENT

BHEL					
ENGINEERING			QUALITY		
	Sign & Date	Name		Sign & Date	Name
Prepared by:	HEMA KUSHWAHA	HEMA KHUSHWAHA	Checked by:		KUNAL GANDHI
Reviewed by:	PRAVEEN DUTTA	PRAVEEN DUTTA	Reviewed by:	RITESH KUMAR JAISWAL	R K JAISWAL

BIDDER/ SUPPLIER	
Sign & Date	
Seal	

FOR CUSTOMER REVIEW & APPROVAL			
Doc No:			
	Sign & Date	Name	Seal
Reviewed by:			
Approved by:			



ANNEXURE - A

NOTES AND DETAILS FOR CABLING SYSTEM

1.00.00 GENERAL

1.01.00 These notes and details shall be read and construed in conjunction with Specification and the drawings meant for cable tray details and supporting arrangements in Trench, Racks etc., enclosed elsewhere. In case of conflict between these notes and drawings, the latter shall prevail.

1.02.00 The Cabling System installation work shall conform to the requirements of the latest revisions of the following standards/codes

- a) Indian Electricity Rules, 1956, with up to date amendment.
- b) I.S. Code of Practice

2.00.00 CABLE ROUTING/LAYING

2.01.01 Cables shall generally be laid on ladder type cable trays either in trenches or overhead supported from building steel/structures except in some cases cables may have to be laid underground and for short runs in conduits for protection or crossing.

2.01.02 For interplant connections, the cables may be routed through an overhead cable bridge or cable trenches/tunnels selection being dependent on site constraints. Directly buried cable shall be avoided as far as possible. Owner's prior approval shall be taken for exceptional cases, where buried cables cannot be avoided.

2.01.03 For underground crossing of railways, roads etc. hume pipes shall be used and shall be laid at a depth of minimum 1000 mm such that cables shall not be damaged.

2.01.04 The cable racks in dust prone areas shall be supported from available structure in vertical configuration with suitable cover to avoid deposition of lignite dust as far as practicable.

2.01.05 Different voltage grade cables shall be laid in separate trays when trays are arranged in tiers. Power cables shall be on top trays and Control/Instrumentation cables on bottom trays, and it is recommended that trays for cables of different voltage levels be stacked in descending order with higher voltage level above.

2.01.06 Cables for redundant equipment/system shall be run in separate trays in separate route.





- 2.01.07 Cables from two different services viz. supply from station board and supply from unit board shall be fully segregated to prevent simultaneous damage due to fire in one of the services.
- 2.01.08 Low level signal cables and other special Instrumentation and Control cables shall run in separate trays. In general, a minimum of 1500 mm clearance shall be maintained between these cables and noise generating equipment (large motors, generators, transformers etc.).
- 2.01.09 The cable spreaders of each unit shall be compartmentalized by provision of fire proof partition wall.
- 2.01.10 The floor of the cable spreader rooms shall have to be made water proof so that water does not percolate to lower levels in the event of fire fighting operations. Adequate arrangement for efficient drainage of water shall be provided. The cable raceways should also be suitably curved to avoid water entry through this place.
- 2.02.00 **Cable Trays/Supports**
- 2.02.01 Cable trays and covers shall be pre-fabricated type, constructed from minimum 14 SWG sheet steel for trays and 16 SWG for covers and hot-dip galvanized after fabrication.
- 2.02.02 Cable tray supports shall be cantilever type for each installation. All supports and hardware shall be hot-dip galvanized. Support shall be fixed with bolts and no welding shall be done on the galvanized parts.
- 2.02.03 Standard cable tray width shall be 600 mm. However, trays with 450, and 300, 150 mm width may be used in some places considering the requirement and space restrictions. For instrumentation and control purpose, some perforated type cable trays of width 150 and/or 100mm may be used particularly in low space area and 600, 450, 300 mm perforated trays may be used depending on site requirement.
- 2.02.04 Cable trays shall be ladder type with 250 mm rung spacing, 100 mm depth and rung width not less than 50 mm.
- 2.02.05 All weld for cable tray supports shall have a minimum throat thickness of 6 mm.
- 2.02.06 Cable trays in areas subjected to excessive lignite dust, or mechanical damage shall have hot-dip galvanised sheet metal tray cover installed on front tray in vertical run and inverted 'V' type on upper tray in horizontal run.
- Where covers are used on trays containing power cables, consideration should be given to ventilation requirements. Areas where corrosive chemicals are likely to be handled, cable tray and covers shall be epoxy painted.
- 2.03.00 **Conduits**





- 2.03.01 Conduits shall be rigid steel coated type; minimum size of conduit shall be limited to 19mm.
- 2.03.02 Steel conduits with interior coating of silicon epoxy ester for ease of wire pulling shall be seamed by welding and flo-coat metal conduit/hot-dip galvanized. These shall be supplied in standard length of 5M with minimum wall thickness as specified in IS: 9537 Part-II. In chemical handling areas, Battery room etc., the exterior surface shall be further coated with chromate and polymer for better resistance to corrosion.
- 2.03.03 Conduit runs shall be supported at an interval of 750 mm for vertical run and 1000 mm for horizontal run.
- 2.03.04 Conduits shall be sized so that conduit fill (ratio of total cable area to conduit area) shall not exceed the following:
- | | | |
|-------------------|---|-----|
| One Cable | : | 53% |
| Two Cable | : | 31% |
| Three Cables & Up | : | 40% |
- 2.03.05 Conduit runs shall be provided with necessary bends as required.
- 2.04.00 **Installation**
- 2.04.01 The Bidder shall install, terminate and connect up all cables and conduits with supporting arrangements as per drawings, cable schedules and interconnection chart/drawings.
- 2.04.02 The HV power cables of 11 KV/3.3 KV shall be laid in trays or racks as follows:
- In single layer only.
 - 3 core cables to be laid giving one diameter gap of the largest diameter adjacent cable.
 - Single core cables to be laid in trefoil formation with a spacing equal to diameter of the trefoils.
- 2.04.03 1100V grade power cables shall be laid in single layer in trays.
- 2.04.04 1100V grade power cable shall be laid giving one diameter gap of the largest diameter adjacent cable.
- 2.04.05 Control and Instrumentation cables can be laid up to a maximum of three layers in each tray.
- 2.04.06 The trays shall be run with a vertical spacing of 300 mm for overhead cable trays as well as inside cable trenches. A minimum of 225 mm clearance shall be provided between the top of tray and beams, cold piping, 500 mm clearance for hot piping/object to facilitate installation of cables in tray.





5.05.02 Components shall be pre-moulded type, taped type or heat-shrinkable type. 11kV, 6.6kV and 3.3kV grade joints and terminations shall be type tested as per IS: 13573.

5.05.03 Kits shall be complete with the aluminium solderless crimping type cable lugs and ferrule as per DIN standard.

5.06.00 **Cable Glands**

Cable shall be terminated using double compression type cable glands. Cable glands shall conform to BS 6121 or to EN 50262. Ingress Protection rating for cable glands with seal, when offered conforming to EN 50262, shall be minimum IP 66 in line with BS. Cable glands shall be made of tinned brass gland, double compression type complete with necessary armour clamp and tapered washer, etc. Rubber components shall be of neoprene or better synthetic material and of tested quality. Cable glands shall match with the sizes of different H.V./L.V./Control cables supplied/erected.

5.07.00 **Cable Lugs**

All cable lugs shall be Cd plated copper. Cable lugs shall be suitable for termination of different cross-sections of H.V./L.V./Control/Instrumentation cables and shall be of following types :

- i) Aluminium tubular terminal end for solderless crimping to aluminium conductors.
- ii) Copper tubular terminal end for solderless crimping to copper conductors.
Solderless crimping of terminals shall be done by using corrosion inhibiting compound. The cable lugs shall suit the type of terminals provided on the equipment. Lugs for control/instrumentation cables shall be PVC insulated/sleeved type.
- iii) Cable lugs for control cable termination shall be insulated. These lugs shall be pin type/flat type/ring type/U type to suit the terminals provided in the panels.

5.08.00 **Cable Clamps and Straps**

5.08.01 Trefoil clamps for single core cables shall be pressure die-cast aluminium or fibre glass or nylon with necessary G I fasteners. Trefoil clamps shall have adequate mechanical strength to forces generated by peak value of maximum system short circuit current.

5.08.02 Cable clamps required for multicore cables on vertical run shall be made up of 25x3mm size aluminium strip. For clamping the multicore cables, self-





- ii) Heat Shrinkable sleeve type for HV & MV cables and LV power cables. However terminating kits for HV & MV cables shall be of heat shrinkable type of make with specific approval of Purchaser.
- e) For outdoor installations, weather shields/sealing ends and any other accessories required shall also form part of the kit.
- f) The straight through jointing kits shall be suitable for underground installation with uncontrolled backfill and possibility of flooding by water. Straight through joints shall be used for LV power cable sizes of 70sqmm and above. The jointing kit shall be one of the following types: -
 - i) 'TAPEX' of M-seal make or equivalent for LV power cables
 - ii) Heat Shrinkable sleeve type for HV & MV cables and LV power cables. However straight through joints for HV & MV cables and LV power cables shall be of heat shrinkable type of make with specific approval of Purchaser.

5.29.02 Raceway & Conduit

The design and specifications for the raceway and conduit systems used in supporting and protecting electrical cable shall be in accordance with the provisions of the appropriate codes and standards.

5.30.00 **Conduit**

5.30.01 Conduit shall be used to protect unarmoured conductors routed to individual devices and where the quantity of cable does not economically justify the use of cable tray.

5.30.02 Rigid conduit shall be used for hazardous and outdoor areas.

5.30.03 Galvanized rigid steel conduit shall be used for all conduit encased in concrete and all exposed conduit.

5.30.04 All conduits cast in concrete shall be routed in exposed runs parallel or perpendicular to dominant surfaces with right-angle turns made of symmetrical bends or fittings. Conduit shall be routed at least 150mm from the insulated surfaces of hot water, steam pipes, and other hot surfaces. Where conduit must be routed parallel to hot surfaces, special high temperature cables shall be used.

5.31.00 **Duct Banks & Manholes**

5.31.01 All underground duct banks shall consist of plastic conduit encased in reinforced concrete. The minimum nominal diameter/hume pipes of the plastic ducts shall be 125mm. A 75mm galvanized steel conduit shall also be installed where required for digital and analog low-level circuits requiring noise immunity from adjacent power circuits.



714945/2022/PS-PEM-MAX

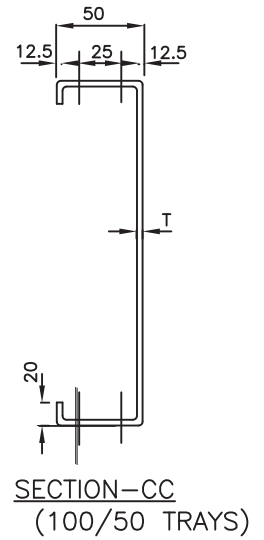
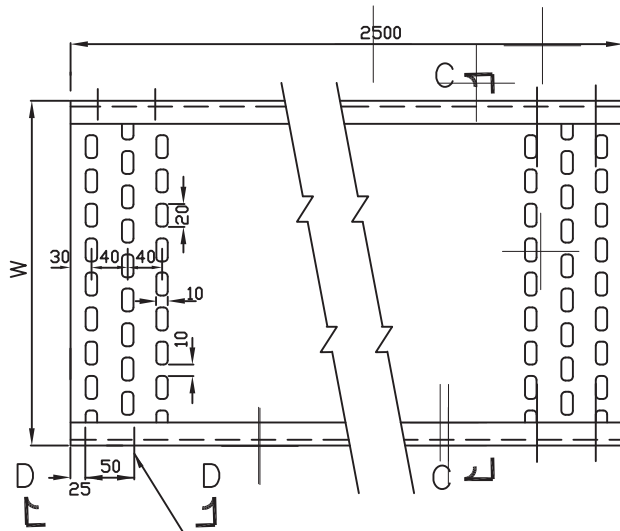

4 HOLES 10mm DIA.

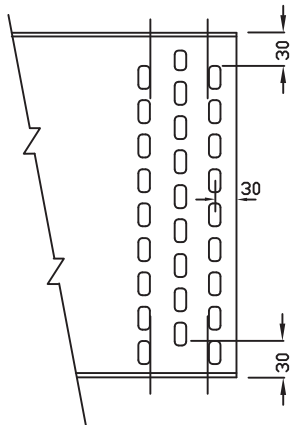

ARRANGEMENT OF PERFORATIONS

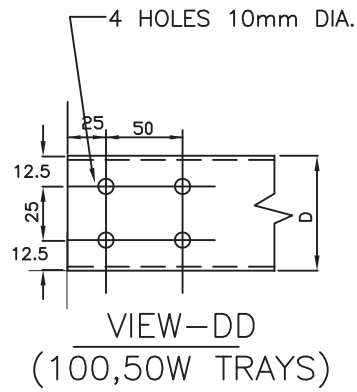

TRAY WIDTH W (mm)	100	50
TRAY DEPTH D (mm)	50	50
T (mm)	2	2

PERFORATED TYPE TRAY



TYPICAL DETAILS OF CABLE TRAYS AND ACCESSORIES

DWG. NO.

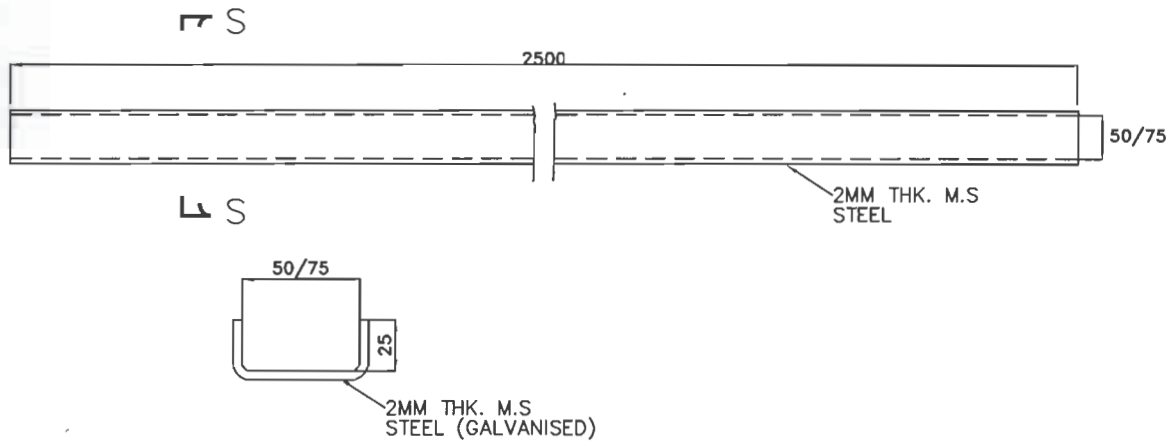

SECTION S-S

CABLE TROUGHS

SEE GENERAL NOTES IN SHEET 11.

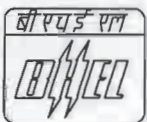

TYPICAL DETAILS OF
CABLE TRAY AND ACCESSORIES

BHEL DRAWING NO.
PE-DG-427-507-E005

SH 10 OF 11

REV 00

714945/2022/PS-PEM-MAX

	2X500 MW NTPL TUTICORIN FGD COMPRESSED AIR SYSTEM	SPECIFICATION No: PE-TS-483-555-A002	
		VOLUME: II B	
		SECTION : C-4	
		REV. 00	DATE: FEB 2022
		SHEET: 1 OF 1	

SECTION: C-4
TECHNICAL SPECIFICATION (C&I PORTION)

INDEX

S. No.	DESCRIPTION	Page No.
1	TITLE SHEET	1
2	INDEX SHEET	2
3	C&I SPECIFIC TECHNICAL REQUIREMENTS	3
4	C&I GENERAL TECHNICAL REQUIREMENT	7
5	INSTRUMENT DATASHEET	22
6	CONTROL DESK/PANEL SPECIFICATION	41
7	INSTRUMENT & CONTROL CABLING & TYPE TEST	58
8	ELECTRIC MOTOR ACTUATOR SPEC	65
9	DRIVE CONTROL PHILOSOPHY	70
10	INTRUMENT INSTALLATION DIAGRAM	77
11	FORMAT OF SOFT SIGNAL EXCHANGE	85
12	STANDARD SIGNAL EXCHANGE B/W COMPRESSOR, DCS AND SWGR	87
13	KKS PHILOSOPHY	89

SCOPE OF C&I FOR COMPRESSED AIR SYSTEM

1. COMPRESSED AIR SYSTEM for FGD plant is **Microprocessor based system** with operator interface and is **common for two** units.
2. The operational facility of each compressor shall also be provided from independent local control panel dedicated for each compressor and one (1) local control panel for Air Drying Plant shall be provided.
3. Annunciation windows and hooter will be driven from microprocessor/microcontroller output card and required annunciation sequence will be programmed in application software of microprocessor/ microcontroller based control system.
4. All indications on the panel, and illumination of annunciation windows shall be provided with clustered LED of required colours as applicable.
5. All commands from station DDCMIS to field devices, MCC/SWGR shall be through interposing relays and shall be routed through microcontrollers of individual compressors.
6. Provision shall also be made to hook-up the compressor control system with DDCMIS through hardware interface for remote start/stop and feedback to/from DDCMIS and monitoring of critical parameters of compressors and air drying plants.
7. In addition to it, Soft signal exchange between the microprocessor to FGD DCS shall be interfaced through Modbus on RS-485 via twisted pair cable (in bidder's scope) for monitoring all the parameters and status feedback of drives of compressed air system. The Dew point measurement from FGD DCS to all the compressors & their status feedbacks to FGD DCS shall also be provided.
8. Integrated microprocessor based control system along with suitable operator interface shall be provided for each Instrument Air Compressor, Service Air Compressor & their Dryers. All transmitter such as PT, DPT, TE and other instruments inside and outside the compressor skid shall also be hooked up to this system. Compressors connectivity to FGD DCS (FGD DCS in BHEL scope) shall be provided for information and overall control.
9. Bidder to furnish the configuration diagram of Microprocessor Based Control System showing communication with the DCS along with the bid. Bidder to furnish write-up & recommended logics for overall control of Air compressors. Bidder to furnish signal exchange list between compressed air system and DCS in BHEL format attached further.
10. Time synchronization of compressor microprocessor system with the DCS has to be done. Bidder to provide necessary hardware/software at their end.
11. The requirements given below are to be read in conjunction with detailed Technical Specification Enclosed in the specification. Further in case of any discrepancy in the requirement with in the same Section noted by the bidder in the specification, the same will be brought to the notice of BHEL in the Form of pre bid clarification. In absence of any pre bid clarification, the more stringent requirement as per interpretation of customer/BHEL shall prevail without any commercial implication.
12. The make/model of various instruments/items/systems shall be as per NTPL approved vendor list. No commercial and delivery implication in this regard shall be acceptable. In case of any conflict and repetition of clauses in the specification, the more stringent requirements among them are to be complied with, the more stringent requirement as per interpretation of customer/BHEL shall prevail without any commercial implication.

13. All instruments shall be terminated on JB/LCP in field and both instruments and JB/LCP are in bidder scope.
14. For cable scope refer to electrical scope between BHEL and vendor defined in electrical specification.
- ~~15. Bidder to provide mandatory spares as per mandatory spares list mentioned elsewhere in the specification.~~
16. Electrical Actuators with integral starter shall be provided for all on/off and inching type valves along with necessary interface units for linking to corresponding Control System as applicable, typical Hook-up diagram of drives is included for reference.
17. The specifications for instruments are included here as minimum requirements. The detail specifications shall be finalized during detail engineering.
18. The bidders shall specifically mention any deviation they would like to take on the C&I specification. In absence of any deviation a No deviation certificate is to be furnished.
19. The quantity of instruments for the system shall be as per tender P & ID wherever provided of the respective system as a minimum, for bidding purpose. However, Bidder shall also include in his proposal all the instruments and devices that are needed for the completeness of the plant auxiliary system/ equipment supplied by the bidder, even if the same is not specifically appearing in the P & ID. During detail engineering if any additional instruments are required for safe & reliable operation of plant, bidder shall supply the same without any price implication. The Contractor shall provide complete Instrumentation for control, monitoring and operation of entire CAS.
20. Bidder to terminate all instrumentation and control elements in junction boxes. bidder to provide input/output list, drives list, junction box schedule and termination details, recommended control logics / write-up etc. the list of documents to be submitted after award of contract is to be referred by bidder.
21. All the transmitters supplied by Bidder shall be rack mounted. The transmitter racks shall be in Bidder's scope of supply. All transmitters shall be HART compatible.
22. Bidder to perform tests of C&I items/instruments/systems as per Quality plans/type test attached in the specification. However, if any test not specified in the quality plan but specified in specification Tests for I&C equipment included elsewhere in specification will have to perform by Bidder without any cost implication.
23. Instrument installation and accessories required for the same shall be in Bidder's scope and shall be submitted after award of contract. However, any instrument/ analyzer installation not covered in the same shall be subject to customer and BHEL approval during detailed engineering.
24. Temperature transmitters shall be provided for all control applications. Transmitter shall be two wire type and current output of 4-20 mA DC with superimposed digital signal in HART protocol. For temperature monitoring functions, temperature elements (TC / RTD) shall be connected to their respective input module of PLC through instrumentation signal / Triad cable in case of RTD type element. extension / compensating cable for K type TC,

NLC Tamil Nadu Power Limited (NTPL)

25. All Temperature sensors shall be Duplex ungrounded type and both the elements shall be terminated at junction box. Extension / Compensating cable for TC and Triad cable for RTD shall be used for interfacing with PLC. Temperature elements shall be supplied with thermowell.
26. Pressure gauges, pressure switches and pressure / differential pressure transmitters shall be provided with diaphragm seal in case of dirty, corrosive & viscous fluid application. Diaphragm material shall be suitable for process fluid. Similarly, the wetted part material for level transmitter / switches / gauges / analysers in corrosive application shall have suitable grade material compatible with the corrosive fluid in contact. In all other cases material grade of the wetted part shall in no case be lower than stainless steel unless the process fluid calls for some other material.
27. Bidder to furnish electrical load/UPS load data during detailed engineering.
28. Bidder to provide temperature transmitter along with compensating cable, JB/Rack & other erection hardware.
29. 230 V AC UPS supply shall be provided by BHEL at a single point, further distribution to various instruments/Equipment's of the system shall be in bidder scope. Bidder to include necessary power distribution board in his scope. Any power supply other than the above, if required by any instrument/equipment has to be derived by the bidder from the above supply & all necessary hardware for the same shall be in bidder scope. Bidder to submit the UPS power requirement along with the bid. Static Switch based Changeover scheme for redundant UPS Feeders shall be used. It shall be ensured that changeover time between feeders shall be such that that compressor Controller Failure shall not take place during changeover.
30. Contractor shall furnish Instrument Schedule, I/O list, Drive list, Cable Schedule, Cable interconnection, JB grouping, Annunciation list, SOE list, List of Instruments/devices for HART in BHEL approved format. The reusable database format like MS Excel, MS Access etc. of these documents shall also be provided by Contractor in BHEL approved format. Soft copy of the formats shall be provided to the successful bidder.
31. Interface of MCC, HT SWGR, field instruments, Actuators etc. with DDCMIS based control system shall be as per Drive Control Philosophy/wiring diagram enclosed in specification.
32. The solenoid operated valves/Dampers/Gate shall have a limit switch for open/close feedback. Solenoid valve shall be rated for 24 V DC only.
33. Redundancy of sensors shall be provided (except skid mounted as per OEM practice)
 - A) Triple redundancy for all analog and binary inputs required for protection of systems/drives.
 - B) For all control functions dual redundancy of the sensors shall be provided by the bidder.
34. Double root valves shall be provided for all pressure tapings where the pressure exceeds 40kg/cm²

35. Use of process actuated switches shall be avoided unless it is proprietary requirement.

36. Number of pair to be selected for screen control cable

(Size :0.5 mm²) F-type: 2P/4P/8P/12P

G-type: 2P/4P/8P/12P

Core Cable: 3CX2.5sqmm²/ 5CX2.5sqmm²/ 12CX1.5sqmm²



VOLUME: II-E

SECTION-I

GENERAL TECHNICAL REQUIREMENTS

- 1.00.00 **INTENT OF SPECIFICATION**
- 1.01.00 This part of the specification is intended to provide the technical guidelines for the Control & Instrumentation system with auxiliaries and accessories for Flue Gas De-sulphurization (FGD) package for 2 x 500 MW of M/s NLC Tamilnadu Power Limited (NTPL) at Tuticorin, in Tamil Nadu.
- 1.02.00 Bidder shall provide all material, equipment and deliverables so as to make a totally integrated Instrumentation and Control System together with all accessories, auxiliaries and associated equipment ensuring operability, maintainability and reliability. The Instrumentation and Control System shall be consistent with modern power plant practices and shall be in compliance with all applicable codes, standards, guides, statutory regulations and safety requirements in force.
- 1.03.00 Bidder shall also include in his proposal and shall furnish all equipment, devices and deliverables which may not be specifically stated in the specification but are needed for completeness of the equipment / systems furnished by the Bidder and for meeting the intent and requirements of the specification.
- 1.04.00 Wherever quantity is indicated, the same refers to only one set per generating unit to be furnished by the Bidder, unless specifically indicated otherwise.
- 1.05.00 It is not the intent to completely specify all details of design and construction features herein. Nevertheless, the instruments / equipment and their installation shall conform to high standards of engineering design and workmanship in all respects.
- 1.06.00 In the event of conflict between requirements of any two clauses of this specification / documents or requirements of different codes / standards specified, the more stringent requirements as per the interpretation of the Owner / Consultant shall apply.





3.00.00 **GENERAL PERFORMANCE REQUIREMENT**

3.01.00 All instruments and control equipment shall be guaranteed to meet the performance, functional and accuracy requirements enumerated in different sections of the specification.

3.02.00 Control & Instrumentation system shall be proven design and from the latest state of the art technology. Any predictable or planned deterioration and / or obsolescence of equipment shall be clearly brought out in the bid.

3.03.00 All instruments / equipment shall be capable of performing satisfactorily in continuous commercial operation conforming to all relevant codes and regulatory requirement under the specified environmental conditions and operating conditions described or implied in this specification without undue heating, vibration, wear, corrosion or other such operating troubles.





- 3.04.00 Instrumentation & Control system shall not impose any limitation or constraint on the operation of the main equipment. It shall be possible to utilize any in-built over capacity in design of any equipment with complete controllability and observability.
- 3.05.00 Mean Time Between Failure (MTBF) of the instruments shall be considerably higher than the equipment they shall cater to in order to avoid shutdown on account of instrumentation failure.
- 4.00.00 **PROVEN PRODUCT**
- 4.01.00 All equipment, systems and accessories furnished under this specification shall be from the latest proven product range of a reputed experienced manufacturer whose successful performance has been established by a considerable record of satisfactory operation in similar plants. Bidder shall furnish satisfactory evidence regarding successful operation and high reliability of the proposed equipment / systems in similar applications for meeting this requirement as specified elsewhere.
- 5.00.00 **WARRANTY**
- Refer Vol IIA of specification.
- 6.00.00 **DESIGN CRITERIA**
- This section lays down the general design criteria to be adapted in designing the instrumentation and control system of the FGD plant.
- 6.01.00 **General**
- 6.01.01 Instrumentation, control and automation shall be designed manufactured and installed taking into consideration the philosophy to satisfy the following requirements:
- a) State-of-the-art proven technology.
 - b) Maximum safety for plant personnel & equipment.
 - c) Reliable and efficient operation under all operating condition.
 - d) High system availability by introduction of adequate redundancies at various levels and low down time.
 - e) Diagnostics capability to pinpoint failure areas.
 - f) Use of public domain software and hardware for easy up gradation.
 - g) System flexibility and modular expansion capability. Modular System design shall be adopted to facilitate easy system expansion. The system shall have the capability and facility for hardware expansion through the





addition of controller modules, I/O cards, peripherals etc., while the existing system is fully operational.

- 6.01.02 Instrumentation, control and automation devices and accessories shall be designed with the following considerations:
- a) Stable in spite of temperature fluctuations.
 - b) Able to withstand high humidity.
 - c) Weather proof.
 - d) Dust proof.
 - e) Corrosion resistant.
 - f) Erosion resistant.
 - g) Able to withstand high vibration.
 - h) Easily accessible for operation & maintenance.
- 6.01.03 Latest version of hardware and software available at the time of system designing shall be provided. In case of future up-gradation of software, Bidder shall remain committed to upgrade the supplied system with the new version within the warranty period, without any additional cost.
- 6.01.04 Bidder shall ensure that supplied controls & instruments should be supported by the supplier such that spare parts are guaranteed to be available for purchase for a period of 15 (fifteen) years. Similarly the service shall also be guaranteed for a period of 15 (fifteen) years.
- 6.01.05 For the sake of completeness of the system for each application and in order to ensure desired performance & safety measures, any hardware or software item as required, shall be in the scope of Bidder irrespective of their explicit or implicit inclusion in the accompanying document. Bidder shall be responsible for proper functioning of the system as a whole or any part thereof and shall render guarantee for all addition/deletion.
- 6.01.06 Control systems shall have their independent redundant Electronic Earth pits for system grounding. These earth pits shall be separate from the Electrical earth pits and located away from the HT equipment. FGD control system (PLC based) shall have independent redundant Electronic & Electrical Earth pits.
- 6.02.00 **Standardization and Uniformity of Hardware**
- To ensure smooth and optimal maintenance, easy interchangeability and efficient spare parts management of various I&C instruments / equipment, the Bidder shall make reasonable efforts that all instruments / devices are of the same make, series and family of hardware. For example, all 4-20mA





electronic transmitters / transducers, control hardware, control valves, actuators and other instruments / local devices etc. being furnished by the Bidder for entire FGD Systems shall be of the same make and series for similar applications, except for the instrument integral to equipment such as Compressor etc. which may be manufacturer specific.

6.03.00 **Reliability & Availability**

6.03.01 All components and systems offered shall be of established reliability. The minimum target reliability of each component / module shall be established by taking into consideration its Mean time between failure (MTBF) and Mean time to repair (MTTR), such that the availability of the complete system is assured for 99.7%.

6.03.02 In order to establish the target reliability, Bidder shall perform necessary availability tests for major systems. Burn-in / Elevated Temperature test reports, not older than 5 (five) years shall be furnished for Owner / Consultant review. Surge protection for solid state systems, selection of proper materials, manufacturing processes, quality controlled components and parts, adequate derating of electronic components and parts shall be ensured to meet the reliability and life expectancy goals.

6.03.03 Redundancy and continuous self-checking features shall be incorporated in system design with automatic transfer to healthy redundant circuits to enhance the reliability of the complete system.

6.03.04 To ensure availability, adequate redundancy in system design shall be provided at hardware, software and sensor level to satisfy the availability criteria of 99.7%. For the protection system, independent sensing device shall be provided to ensure adequate safety of plant equipment.

6.04.00 **Operability & Maintainability**

6.04.01 The system shall be designed such that any 'single-failure' should not lead to loss of availability of the plant, modification in operating routine or degradation of performance. This shall be achieved by judicious introduction of redundancy at all critical levels like providing redundant power supply, hot-standby multi loop controllers, redundant IO modules (for all critical application), redundant IO network and data highways, redundant communication modules, duplicating console functions and servers and redundant field instruments. The plant operator remains totally transparent to 'single-failures'.

6.04.02 Control system shall be designed in a fail safe mode so that loss of signal, loss of excitation, loss of motive power or failure of any component shall not cause a hazardous condition for the plant & personnel and at the same time prevent occurrence of false trips. All modulating control valves shall be in stay put condition during any of the above failures.

6.04.03 Control consoles shall be designed for operation of the FGD system with





minimum operational manpower deployment. Bidder shall ensure proper operability and also take into account protections to minimize accidental mal-operations.

6.04.04 On-line testing, self-checking & diagnostic facility of control system shall be provided with indication for easy identification of the faulty module, while the unit is in operation. The system shall continuously check health of its modules including its redundant part and shall permit carrying out of the on-line dynamic test and self-diagnostic checks while maintaining safe condition without endangering the safety of equipment and without having any influence on the process being controlled.

6.04.05 Intercommunications in between sub-racks and system termination cabinets and in between sub racks and other panels shall be made by prefabricated connectors and cables with mechanical latch.

6.05.00 **Security and Failure Philosophy**

6.05.01 **General**

Control & instrumentation system shall meet the following requirements:

- a) No single failure shall cause the complete failure of the control.
- b) No single fault shall cause the protection system to spuriously operate or cause the protection system to become inoperative or / cause a trip or derate the unit.
- c) Due to control system failure if a final control element or plant item does not respond then that item or control element shall go into a fail-safe condition or in stay put condition as per the process requirement.
- d) Measure shall be taken on the action of IO due to loss and restoration of power. For example dual outputs such as separate start and stop outputs for motor starters / breakers etc. shall be provided.
- e) Fault on a cable does not cause loss of more than a minimum tolerable functionality of the system.

To meet the above requirement, control system shall incorporate redundancy with continuous self checking so that any internal fault can be detected prior to resulting any disturbance in the process. Protection and safety systems shall incorporate both channel redundancy and measurement redundancy with self checking and adequate test facilities.

Redundancy of components and systems shall be dictated by availability criteria to ensure the system availability target as well as safety considerations are fully met.

6.05.02 **Measurement & Channel Redundancy**

To meet the failure and self-checking criteria for the control system, measurement redundancy shall be provided for all the critical parameters.





Throughout the control system the security and validity of signals are to be ensured adhering to the following design principles.

- a) Where a plant measurement is to be duplicated or triplicated such signals shall be separately fed to the different input modules.
- b) Signals after the security and validity checking by means of voting, averaging, median, difference monitoring or similar technique shall be transmitted to the control functions of sequencing, modulating and protection.
- c) Where double measurements are used, provision shall be made for the selection of either measurement as the duty signal and continuous monitoring of difference between the signals.
- d) For binary and analog inputs, which are required for protection of more than one equipment as well as protection signals for HT drives, triple sensing devices / signals shall be provided.
- e) For binary and analog inputs required for other modulating control, protection and interlock conditions purpose of their equipment and other critical monitoring applications etc. minimum dual instruments/sensors shall be provided.
- f) Dual instruments / sensors shall be provided for instruments required for auto-starting of pumps or pump tripping due to discharge pressure very low.
- g) Measurement system, CLCS and OLCS shall all be configured with redundancy at processor modules, communication modules, data bus and power supply modules. All servers shall be dual redundant.
- h) Redundancy in input / output modules
 - i) Wherever redundant sensors are employed each sensor shall be wired to a separate input module so that even if one input module fails, the parameter shall be available from the other input module.
 - ii) Redundancy in input / output module shall be provided for all HT (11KV & 3.3 KV) drives, critical LT drives and critical modulating control drives so that any single failure of the input / output module shall not lead to the failure / disturbance of process. Critical LT drives/ modulating control drives shall be finalized by the Owner / Consultant at the time of Detail engineering.

i) Data Highway Redundancy

There shall be Redundancy in the system for high reliability of communication. The redundant buses shall work continuously. All communication modules, bus couplers, bus interfaces etc. shall also be hot redundant.

Communication between the operator station and the PLC control processors shall be by means of hot redundant data highways. Redundancy failure shall also be indicated in operating station.

All soft links amongst various PLC / proprietary control systems / Station DCS shall be redundant.





- j) Redundancy for Power supply unit
All power supply feeders from UPS (in parallel mode having 50% load sharing) shall be redundant with auto changeover in each ACDB / DCDB panel. Any kind of bulk power supplies if used shall be redundant.
- k) Redundancy in Operator Console
Operators' Consoles shall have fall back feature so that in case of failure of any console, its functions can be taken up in an adjacent console.

6.05.03 Each C&I cables shall have at least 20% or one no., whichever is maximum, spare wire capacity above the used cores for future maintenance.

6.06.00 **Instrument Accuracy, Standard Scales and Ranges**

6.06.01 **Instrument Accuracy**

- a) Accuracy of linear instruments shall meet the specified accuracy over its span.
- b) Flow meter shall meet the specified accuracy criteria when operating between 25 and 100 percent of full-scale flow value. The accuracy guarantee shall include the effect of errors in the differential head measuring device, square root converter and signal generator.
- c) Level measurement shall be linear with respect to the measured level based on a specific gravity of 1.00.
- d) Wherever the measured parameter like flow is influenced by process pressure & temperature, required correction against pressure and temperature shall be introduced for such measurement.
- e) Temperature compensation shall produce corrections over a flow range from 10 percent to 100 percent of maximum flow subject to a plus or minus tolerance of one-half of one percent of the maximum flow.

6.06.02 **Instrument Scale Displays**

- a) All displays shall be in engineering units. Instrument scales displayed on screen shall have graduations with scale divisions based on multiples of 10. The smallest division shall preferably be a whole number approximately 1% of the scale range if not otherwise impracticable.
- b) Pressure instrument shall have the unit suffixed with 'a' or 'g' to indicate absolute or gauge pressure, respectively.





- c) Scales and charts of all instruments shall have linear graduations

6.06.03 **Instrument Ranges**

Unless otherwise impractical, Instrument range shall be selected in such a way so that the normal reading lies within 50% to 70% of full scale for linear parameters and within 70% to 90% of full scale for flow measurements. Deviation indicators shall have the null position at mid-scale. The normal operating parameter shall be identified with a clear green mark.

6.07.00 **Environmental Conditions**

- 6.07.01 Control & Instrumentation system shall be suitable for continuous operation in the environmental condition as per the project metrological data provided elsewhere in the specification and shall meet the minimum design requirement of 50°C and 95% RH.

Equipment which cannot meet the stipulated environmental condition shall be installed in air conditioned environment..

- 6.07.02 Particulate contamination from fly ash and coal dust and gaseous contaminants such as SO₂ and other flue gas constituents in the plant can have deleterious effect on printed circuit board, connectors and components. This hazard shall be taken into design considerations.

- 6.07.03 Instruments, devices and equipment for location in outdoors/ indoor/ air-conditioned areas shall be designed to suit the environmental conditions indicated below and shall be suitable for continuous operation in the operating environment and also during periods of air conditioning failure without any loss of function, or departure from the specification.

SL. NO.	LOCATION	ENCLOSURE TYPE
1.	Indoor type non- ventilated enclosure in non-hazardous area	IP-54
2.	Indoor type ventilated enclosure in non-hazardous area	IP -42
3.	Enclosure in Air conditioned area	IP-32 with suitable canopy at top to prevent ingress of dripping water.
4.	Outdoor type in non-hazardous areas	IP-65 with anticorrosion coating.
5.	Outdoor in hazardous areas	As per requirements of the NEC Code for the location





6.08.00 **Name plate**

6.08.01 Each instrument / item of plant shall have nameplate, permanently attached to it in a prominent position, made of non-hygroscopic & non-corrosive material (generally stainless steel) upon which is to be engraved as per the existing philosophy.

6.08.02 Stainless steel tag plate shall be wired to the instrument. Inscription on equipment (labels) shall be in English.

6.08.03 Caution / Danger & Hazardous name plates shall be in English, Tamil & Hindi.

7.00.00 **CODES AND STANDARDS**

7.01.00 The design, construction and testing of all equipment, facilities, components and systems shall be in accordance with standards/ codes issued by Bureau of Indian Standards (BIS) and/or equivalent international standards/ codes. A non-exhaustive list of reputed international standards is given below:

- a) American National Standards Institute (ANSI)
- b) American Petroleum Institute (API)
- c) American Society of Mechanical Engineers (ASME)
- d) American Society of Testing and Materials (ASTM)
- e) American Water Works Association (AWWA)
- f) American Welding Society (AWS)
- g) British Standards (BS)
- h) Deutsches Institut fur Normung (DIN), Germany
- i) Heat Exchange Institute (HEI), USA
- j) Hydraulic Institute Standards (HIS), USA
- k) International Electro-technical Commission (IEC)
- l) Institute of Electrical and Electronics Engineers (IEEE)
- m) International Organisation for Standardization (ISO)
- n) National Electric Code (NEC), USA
- o) National Electrical Manufacturers Association (NEMA), USA
- p) National Fire Protection Association (NFPA), USA
- q) Tubular Exchanger Manufacturers Association (TEMA), USA
- r) VDE association for Electrical, Electronic and Information Technologies (VDE), Germany





Other International Standards, equivalent or superior to the above Standards can also be adopted. However, in the event of any conflict between the requirements of the International standards / codes and the requirements of the BIS standards / codes, the latter shall prevail.

7.02.00 The following latest edition of codes and standards prevailing at the time of award of contract shall generally be applicable.

1) **Temperature Measurement**

- a) Instrument and apparatus for temperature measurement - ASME PTC 19.3 (1974).
- b) Temperature Measurement - Thermocouples - ANSI - MC 96.1 - 1982.
- c) Temperature Measurement by electrical resistance thermometers - IS: 2806
- d) Thermometer-element-Platinum resistance - IS: 2848 / DIN 43760.

2) **Pressure Measurement**

- a) Instrument and apparatus for pressure measurement - ASME PTC 19.2 (1964).
- b) Bourdon tube pressure and vacuum gauges - IS: 3624/1996.

3) **Flow Measurement**

- a) Instruments and apparatus for flow measurement - ASME PTC 19.5 (1972) Interim supplement, Part-II.
- b) Measurements of fluid flow in closed conduit - BS 1042.

4) **Electronic Measuring Instruments and Control Hardware**

- a) Automatic null balancing electrical measuring instruments -ANSI C 39.4 (Rev. 1973), IS 9319
- b) Safety requirements for electrical and electronic measuring and controlling instrumentation - ANSI C 39.5 / 1974.
- c) Compatibility of analog signals for electronic industrial process instruments - ISA-S 50.1: ANSI MC 12.1 / 1975.
- d) Dynamic response testing of process control instrumentation - ANSI MC 4.1 (1975) - ISA -S26 (1968).
- e) Surge withstand capability (SWC) tests - ANSI C 37.90A (1989), IEC / EN 61000-4-4 & IEC / EN 61000-4-5.





- f) Printed circuit boards – IPC-TM-650, IEC 326-2 & IEC 326-4.
 - g) General requirements and method of tests for printed wiring boards - IS-7405 (Part-I) /1994, IEC 326-2.
 - h) Edge socket connectors - IEC 130-11.
 - i) Requirements and methods of testing of wire wrap terminations-- DIN 41611 Part-2.
 - j) Dimensions of attachment plugs and receptacles- ANSI C73-1973.(Supplement ANSI C73a – 1980)
- 5) **Instrument Switches and Contacts**
- a) Contact Rating - AC services NEMA ICS Part-2 125, A-600
 - b) Contact Rating - DC services NEMA ICS Part-2 125, N-600
- 6) **Enclosures**
- a) Enclosures for Industrial Controls and Systems–NEMA ICS-6-110.15 through 110.22
 - b) Racks, panels and associated equipment -EIA: RS-310-B-1983 (ANSI C83.9 - 1972)
- 7) **Apparatus, Enclosures and Installation Practices in Hazardous Area**
- a) Classification of hazardous area - NEMA Article 500, Volume-6, 1978.
 - b) Electrical Instruments in hazardous dust locations - ISA-RP 12.11.
 - c) Intrinsically safe apparatus - NFPA Article 493 Volume-4 1978.
 - d) Purged and pressurized enclosure for electrical equipment in hazardous location - NFPA Article 496 Volume-4, 1978.
- 8) **Annunciators**
- a) Specifications and guides for the use of general-purpose annunciators - ISA 18.1- (1979) (R2004).
 - b) Surge withstands capability tests - ANSI C37.90 -1989 / IEC /EN 61000-4-4 & IEC /EN 61000-4-5.
- 9) **Interlocks, Protections**





- a) Relays and relay system associated with electric power apparatus - IEEE Standards 3.13.
- b) Surge withstands capability tests - ANSI C37.90 a - 1971 and IEEE Standard 472-1974.
- c) General requirements and tests for switching devices for control and auxiliary circuits including contactor relays - IS-6875 (Part-I)/1973.

10) **UPS System**

- a) Practice and requirements for semi-conductor power rectifiers - ANSI C34.2.
- b) Relays and relay systems associated with electrical power apparatus IEEE Standard - 3.13.
- c) Surge withstands capability tests - ANSI C 70.90 A/1971, IEC-255.4.
- d) Recommended practice for sizing large lead storage batteries for generating stations and sub-stations -IEEE-485.

11) **Control Valves**

- a) Control valve sizing (Incompressible fluids) - ISA-S39.1 / 1972.
- b) Control valve capacity test (Incompressible fluids) -ISA-S39.2 / 1972.
- c) Control valve sizing (Compressible fluids) - ISA-S39.3 / 1972.
- d) Control valve capacity test (Incompressible fluids) -ISA-S39.4 / 1972.
- e) Control Valve seat leakage – ANSI / FCI 70.2
- f) Face to face dimensions of Control Valves - ANSI B16.10
- g) Control Valve Capacity Test Procedure – ISA – 575.02

12) **Instrument Tubing**

- i) Seamless Carbon Steel Pipe - ASTM-A-106.
- ii) Forged carbon steel fittings - ASTM-A-105.
- iii) Dimensions of fittings - ANSI-B16.11.





- iv) Code for pressure piping, welding, hydrostatic testing - ANSI-B 31.1.
 - v) Nomenclature for instrument tube fittings - ISA-RP 42.1 / 1982.
 - vi) Seamless Stainless Steel Tube ASTM A-213 TP 316 / ASTM A-269 TP 316
 - vii) Seamless Alloy Steel Pipe ASTM A 335 P22
 - viii) Seamless Stainless Steel Pipe ASTM A-312 TP 316
- 13) **Cables**
- a) Thermocouple extension wires / cables - ANSI MC96.1.
 - b) Insulated Wire and Cable for the Transmission and Distribution of Electrical Energy-IPCEA S-61-402
 - c) Guide for design and installation of cable system in power generating station (insulation, jacket materials)-IEEE Standard 422.
 - d) Requirements of vertical tray flame test - IEEE 383
 - e) Standard specification for tinned soft or annealed copper wire for electrical purpose - ASTM B33.
 - f) Specification for PVC insulated (heavy duty) electric cables or (Latest revision) equivalent - IS-1554 Part-1
 - g) Conductors for insulated electric cables and flexible cords or equivalent - IS-8130, 1984
 - h) PVC insulation and sheath of electric cables or equivalent - IS-5831
 - i) PVC insulated cables for working voltage upto and including 1100 volts or equivalent - IS-694 (Latest)
 - j) Mild steel wires, formed wires and tapes for armoring of cable or equivalent - IS-3975
 - k) Test on single vertical insulated wire or cable - IEC 332 (Part-1)
 - l) Swedish Chimney Flame Test - SS 424-1475
 - m) Test methods for insulations and sheaths of electric cables and cords - IEC 540



- n) Colour coding of instrumentation cables - VDE 0815
 - o) Minimum oxygen concentration to support candle-like combustion of plastics - ASTM D2863
 - p) Density of smoke from the burning of decomposition of plastics - ASTM D2843
 - q) Test on gases evolved during combustion of materials from cables - IEC 754
 - r) Determination of the amount of halogen acid gas - IEC 754 (Part-1)
 - s) Methods of test for cables - IS 10810
 - t) Drums for electric cables - IS: 10418
- 14) **Electronic Cards, Subassemblies and Components**
- a) **Unpackaged**
 - i) Vibration : IEC-68.2.6
 - ii) Shock : IEC-68.2.27
 - iii) Drop & Topple : IEC-68.2.31
 - b) **Packaged**
Vibration, Drop & Static Compression - NSTA.
 - c) **Electromagnetic Compatibility / Immunity**
 - i) Electrical Fast Transient immunity : IEC / EN 61000-4-4
 - ii) Surge Immunity : IEC /EN 61000-4-5
 - iii) Radiated Electromagnetic Field : EN 61000-4-3
 - iv) Electrostatic Discharge immunity : EN 61000-4-2
 - v) Electromagnetic Emissions : VDE 0871, Class-B
- 15) **Cable Trays, Conduits**
- a) Guide for the design and installation of cable system in power generating station (cable trays, support systems, conduits)- IEEE Standard 422, NEMA VE-1, NEC-1981. Test Standards NEMA VE-1-1979.
 - b) Galvanizing of carbon steel cable trays - ASTM A-386.





Tender Specification
for
FGD Package

NLC Tamil Nadu Power Ltd.
2x500 MW Project
Tuticorin, Tamil Nadu

VOLUME : II-E

SECTION-III

INSTRUMENTATION AND CONTROL SYSTEM

1.00.00 FIELD INSTRUMENTS

This section provides general guidelines for field instruments, systems and equipment to be supplied under this specification, **as applicable for the Bidder's Scope of Work** for completeness of C&I system. All measuring instruments / equipment and systems / sub-systems offered by Bidder shall be from reputed experienced manufacturer of specified type and range of equipment, whose guaranteed and trouble free operation has been established. All instruments / equipment shall be of proven reliability, accuracy, repeatability requiring a minimum of maintenance and comply with the acceptable international standards. All instruments / equipment and accessories shall be supplied as per technical specifications, ranges, make as approved by Owner / Consultant.

All local gauges as well as transmitters, sensors, and switches for parameters like pressure, temperature, level, flow etc. and vibration transmitters as required shall be provided. In general, transmitters shall be provided for remote monitoring, alarm, interlock and control. Use of process actuated switches shall be avoided as far as possible unless the same is required as per manufacturer's standard & proven practice.

All field instruments shall be weatherproof, drip tight, dust tight and splash proof suitable for use under outdoor ambient conditions prevalent in the subject plant. All field-mounted instruments shall be mounted in suitable locations where maximum accessibility for maintenance is achieved. The enclosures of all electronic instruments shall conform to IP-65 unless otherwise specified.

For all instruments envisaged for corrosive liquid applications, they shall be provided with wetted parts made of Monel / Hastelloy C or any other material (if provenness experience of the proposed material for such applications is established by Contractor).

All instruments shall be provided with durable epoxy coating for housings and all exposed surfaces of the instruments. Anti-corrosive paint shall be applied to the field mounted enclosures / instruments.





**Tender Specification
for
FGD Package**

**NLC Tamil Nadu Power Ltd.
2x500 MW Project
Tuticorin, Tamil Nadu**

1.01.00 Pressure, Differential Pressure, Flow and Level Transmitter

- | | | | | |
|-----|------------------------|---------------|--|--------------------------------|
| 01. | Working Principle | : | Smart | |
| 02. | Type | : | 2-Wire | |
| 03. | Output signal | : | Simultaneous transmission of digital and 4-20 mA DC signal. HART protocol. | |
| 04. | Signal Processing Unit | : | Silicon solid-state electronic circuitry | |
| 05. | Measuring element | : | Capsule/Diaphragm | |
| 06. | Element material | : | AISI-316 (Stainless Steel) or better | |
| 07. | Over Pressure | : | 150% of maximum pressure | |
| 08. | Turn-down ratio | : | 10:1 for vacuum / very low pressure application.

30:1 for other application | |
| 09. | Span and Zero | : | Continuous non-interacting tamper proof, remote as well as manual adjustable from instrument with zero suppression and elevation facility. | |
| 10. | Enclosure | : | Epoxy coated Die cast aluminium. IP-65 (Explosion proof for NEC Class-1, Division 1 area) with ½" NPT (F) cable entry. | |
| 11. | Output Indicator | : | LCD type | |
| 12. | Body | : | Forged Carbon Steel (SS for DM Water) | |
| 13. | Operating Voltage | : | 24 V DC \pm 10% | |
| 14. | Load | : | 600 Ohms (min.) at 24 Volts DC | |
| 15. | Performance :- | | | |
| | a) | Accuracy | : | \pm 0.1 % of span or better |
| | b) | Repeatability | : | \pm 0.05 % of span or better |
| | c) | Response time | : | 250 msec or better |





**Tender Specification
for
FGD Package**

**NLC Tamil Nadu Power Ltd.
2x500 MW Project
Tuticorin, Tamil Nadu**

- d) Zero & Span drift : 0.015% per Deg.C at max span
0.11% per Deg.C at min span
- e) Stability : 0.1% of calibrated span for six months for ranges upto and including 70 Kg/ sq.cm.
0.25% of calibrated span for six months for ranges more than 70 Kg/ sq.cm (g).
16. Process connection : ½" NPT (F)
17. Sealing / Isolation : Extended diaphragm with 5 meters SS armoured capillary for corrosive, viscous and dirty fluid applications. Material for separator diaphragm, depending on application.
18. Nameplate : Tag number and Service engraved in stainless steel tag plate
19. Accessories : a) Installation accessories such as mounting bracket, high tensile carbon steel U-bolts suitable for pipe mounting.
b) ½" NPT 2-valve stainless steel manifold, constructed from SS316 bar stock for pressure transmitter.
c) ½" NPT 5-valve stainless steel manifold, constructed from SS316 bar stock for DP transmitter. 3 valve manifold for DP application in flue gas and air.
d) Companion flange with nuts, bolts and gaskets.
e) ½" NPT cable gland

1.02.00 Ultrasonic Level Transmitter

01. Principle of operation : Detection of reflected ultrasonic pulse





**Tender Specification
for
FGD Package**

**NLC Tamil Nadu Power Ltd.
2x500 MW Project
Tuticorin, Tamil Nadu**

- | | | | |
|-----|----------------------------|---|---|
| 01. | Type | : | Radar based on Time Domain Reflectometry / Pulse / FMCW as per application |
| 02. | Antenna | : | Co axial / single rod type guided wave or Horn type as required for the application |
| 03. | Communication | : | Two wire 4-20mA DC, HART protocol |
| 04. | Enclosure | : | Explosion proof /IP 65 as per application |
| 05. | Cable Entry | : | ½" NPT |
| 06. | Calibration | : | a) Self calibration with internal reference
b) Zero & Span calibration |
| 07. | Programming | : | Handheld programmer & Local keypad |
| 08. | Process Connection | : | Flanged /screwed |
| 09. | Electronic Housing | : | Epoxy painted Die-Cast aluminium alloy |
| 10. | Antenna / Flange assembly: | | 316 SS or Hestallo (as required) |
| 11. | Output Indicator | : | Digital Integral Display |
| 12. | Accuracy | : | 5 mm or 0.1% of probe length |
| 13. | Accessories | : | a) Programming tool kit, if required
b) Gasket |

1.04.00 Pressure Gauge and Differential Pressure Gauge

- | | | | |
|-----|----------------------|---|--|
| 01. | Type | : | Bourdon/Bellows/Diaphragm |
| 02. | MOC Sensing & Socket | : | AISI-316 SS |
| 03. | Movement Material | : | AISI-304 SS |
| 04. | Case Material | : | Stainless steel. Enclosure IP-65. |
| 05. | Dial Size | : | Generally 150 mm (100 mm for SWAS gauges) |
| 06. | Scale | : | Black lettering on white background in 270 Deg. arc. |





**Tender Specification
for
FGD Package**

**NLC Tamil Nadu Power Ltd.
2x500 MW Project
Tuticorin, Tamil Nadu**

- | | | | |
|-----|---------------------------|---|--|
| 07. | Window | : | Shatterproof glass |
| 08. | Range Selection | : | Normal process pressure – 50 ~ 70% of range (approximately). |
| 09. | Over-range Protection | : | 125% of maximum range by internal stop. External stop at zero. |
| 10. | Adjustment | : | Micrometer screw for zero adjustment. |
| 11. | Element Connection | : | Argon welding |
| 12. | Process Connection | : | 1/2" NPT (M) Bottom connection for local mounting, back connection for panel mounting. |
| 13. | Performance | : | Accuracy of $\pm 1.0\%$ of span or better. |
| 14. | Safety Feature | : | Blow out disc /diaphragm at the back |
| 15. | Accessories | : | <ul style="list-style-type: none"> a) Snubbers and Glycerin filled for pulsating fluid applications. b) Stainless steel Diaphragm seals for corrosive, viscous and solid-bearing or slurry type process fluids. c) Gauge saver wherever required d) 3-Way stainless steel Gauge valve for pressure gauges. Process connection 1/2" NPT. e) 5-valve SS316 manifold constructed from barstock for differential pressure gauge. Process connection 1/2" NPT. f) Union, nut & tail piece and other Installation accessories as required. |
| 16. | Applicable standard | : | IS-3624 / 1996 |
| 17. | Electrical Contact rating | : | Not applicable |
| 18. | Nameplate | : | Tag number, service engraved in stainless steel tag plate |





**Tender Specification
for
FGD Package**

**NLC Tamil Nadu Power Ltd.
2x500 MW Project
Tuticorin, Tamil Nadu**

1.05.00

Pressure Switch and Differential Pressure Switch

- | | | | |
|-----|----------------------------|---|---|
| 01. | Type | : | a) Piston for high pressure application
b) Bellow / Diaphragm for low pressure application |
| 02. | Sensing element material : | | AISI SS-316. All other wetted part SS316. |
| 03. | Case Material | : | Epoxy coated Die-cast aluminum alloy with neoprene gasket. |
| 04. | Setter Scale | : | Required. |
| 05. | Over range | : | 150% of maximum pressure |
| 06. | Adjustments | : | Internal Set Point adjustable over span |
| 07. | Process Connection | : | 1/2" NPT (M) bottom connected |
| 08. | Switch configuration | : | One DPDT (Two SPDT) |
| 09. | Switch Rating | : | 240V, 5A AC/220V, 0.5A DC |
| 10. | Switch Type | : | Snap acting, shock & vibration proof |
| 11. | Terminal Block | : | Suitable for full ring lugs for cable connection. |
| 12. | Cable connection | : | 1/2" NPT conduit connection or compression gland. |
| 13. | Enclosure Class | : | IP-65 (Explosion proof for NEC Class-1, Division 1 area). |
| 14. | Performance | : | Repeat accuracy $\pm 1.0\%$ |
| 15. | Nameplate | : | Tag number, service engraved in stainless steel tag plate |
| 16. | Accessories | : | a) Remote diaphragm seal with SS-316 capillary for viscous & corrosive application. MOC of seal material shall be as per process fluid requirement.
b) Retention ring and screws for surface mounting. |





**Tender Specification
for
FGD Package**

**NLC Tamil Nadu Power Ltd.
2x500 MW Project
Tuticorin, Tamil Nadu**

- r) Accessories : Cable gland, mounting accessories.
- s) Application : Sludge pits and overhead tanks containing slurry, viscous and dirty fluid like slaked lime, lime preparation tank etc.

1.07.00 Gauge Glass

01. Type : Reflex or transparent. Resistant to mechanical shocks by steel armour.
02. Glass : Toughened borosilicate
03. Body material : forged Carbon steel / stainless steel as per process requirements
04. End connection : As per ASME PTC and drain /vent valve 15NB
05. Accuracy : $\pm 2\%$
06. Pressure rating : Twice the maximum working pressure
07. Scale : Linear vertical
08. Range selection : Covers 125% of max. of scale
09. Test Pressure : 1.5 times to the max. design pressure at 38°C
10. Housing : CS /304SS
11. Accessories : SS Ball check valves, gaskets, companion flange, SS drain and vent valve, nuts & bolts etc.

1.08.00 Sight Glass

01. Type : Flap-type
02. End connection : Screwed / Flanged
03. Material :
 - a) Body : SS-304
 - b) Cover Plate : SS-304
 - c) Indicator : SS-316
04. Sight Glass : Toughened Borosilicate





**Tender Specification
for
FGD Package**

**NLC Tamil Nadu Power Ltd.
2x500 MW Project
Tuticorin, Tamil Nadu**

- | | | | |
|-----|-------------------------|---|------------------------------------|
| 05. | Gasket | : | Neoprene |
| 06. | Bolts & Nuts | : | High tensile steel |
| 07. | Hydraulic Test Pressure | : | 1.5 times maximum working pressure |
| 08. | Accessories | : | As required |

1.09.00 Temperature Gauge

- | | | | |
|-----|--------------------------------|---|---|
| 01. | Type | : | Bimetallic & all angle tiltable |
| 02. | Sensing Element Material: | : | Bimetal strip helix |
| 03. | Stem Diameter | : | 1/4" |
| 04. | Stem Material | : | AISI 304 |
| 05. | Thermometer connection to well | : | 1/2" NPT / SS 304 |
| 06. | Case Material | : | Sturdy, corrosion resistant series 304 stainless steel case and bezel. |
| 07. | Dial Size | : | 5" in general |
| 08. | Scale | : | Anti parallax heavy gauge aluminum with white matte finish glare free. Black lettering on white background. |
| 09. | Pointer | : | Balanced, lightweight aluminum with matte black finish. |
| 10. | Dampener | : | Dampening pointer oscillation |
| 11. | Mounting | : | Surface with adjustable angle. |
| 12. | Over range Protection | : | 150% of range or more |
| 13. | Dial connection | : | Back connection with stem |
| 14. | Range | : | Normal temperature – 50 ~ 70% of range approximately. |
| 15. | Zero adjuster | : | Adjustable screw at back. |
| 16. | Window | : | Shatterproof glass. |
| 17. | Accuracy | : | ±1 % or better (Grade A / ASME B40.3) |





**Tender Specification
for
FGD Package**

**NLC Tamil Nadu Power Ltd.
2x500 MW Project
Tuticorin, Tamil Nadu**

18. Enclosure Class : IP-65
19. Accessories : a) Forged/bar stock thermowell screwed as per ASME PTC code. Process connection M 33X2 (M).
- Material of construction of Thermowell:
- SS 316: In general
 - Inconel: For flue gas application
 - Tungsten carbide: For lignite mill application.
- Bidder shall provide Wake frequency calculation for thermowell as per ASME PTC 19.3 (latest edition).
- b) Installation accessories as required.
20. Nameplate : Tag number, service engraved in stainless steel tag plate

1.10.00 Thermocouples

01. Type : a) Type-K (Chromel-Alumel)
b) Duplex
c) Ungrounded
02. Wire gauge : 16 AWG for Type-K
03. Standard : ANSI-MC 96.1 for thermocouple
04. Protecting Tube :-
- a) O.D. : 8 mm
 - b) Material : 316-SS Seamless
 - c) Filling : Magnesium Oxide (Purity above 99.4%)





**Tender Specification
for
FGD Package**

**NLC Tamil Nadu Power Ltd.
2x500 MW Project
Tuticorin, Tamil Nadu**

05. Characteristics : Linear with respect to temperature within $\pm 1/2\%$ of top range value
06. Accuracy : As per IEC 751 / ANSI MC 96.1 (special class)
07. Head :
- a) Type : IP-65 universal screwed type. (Explosion proof for NEC Class-1, Division 1 area)
- b) Material : Epoxy coated Die cast aluminum or better
- c) Terminal blocks : Nickel plated Brass - screw type/ silver plated
- d) Instrument connection to well : $1/2$ " NPT
- e) Cable connection : $1/2$ " NPT gland and grommet.
- f) Others : Terminal head cover with SS chain and suitable gasket
08. Accessories :
- a) Adjustable nipple-union-nipple [$1/2$ " Sch 80 X $1/2$ " NPT (M)] with thermowell connection
- b) Compression fittings/unions
- c) Flanges etc. (for flanged connections only)
- d) Forged/bar stock thermowell as per ASME PTC 19.3 code. Process connection M 33X2 (M) in general or $1/2$ " Flanged for Flue gas/ /Air etc. application.
- e) Material of construction of Thermowell:
- SS 316: In general
 - Inconel: For flue gas application
- Bidder shall provide Wake frequency calculation for thermowell as per ASME PTC 19.3 (latest edition).





**Tender Specification
for
FGD Package**

**NLC Tamil Nadu Power Ltd.
2x500 MW Project
Tuticorin, Tamil Nadu**

09. Nameplate : Tag number, service engraved in stainless steel tag plate

Notes:

1. Extension cable exposed to atmosphere in the conventional method melts away due to high temperature, at the top of mill or due to lignite burning. Hence the terminals of temperature sensors shall not be at the top of mills itself. The temperature sensors wires are to be laid up to JB through SS tube of required diameter and the head shall be placed nearer to the JB.
2. Thermocouples provided for steam services like MS temp, HRH, CRH, Turbine metal temp, super heater / de super heater area, where the process pipe is inside the insulation of boiler penthouse, Thermowells are inaccessible and terminal head and connecting cable cannot withstand high temperature, for such services thermocouples shall be provided with flexible extension SS316 Sheath of 10-15 meters.

1.11.00 Resistance Temperature Detector

- | | | |
|---------------------|---|--|
| 01. Type | : | Platinum (Duplex), Ungrounded |
| 02. Resistance | : | 100 ohm at 0 degC |
| 03. Base | : | Wound on ceramic (anti-inductive) |
| 04. Wiring | : | 3 /4 Wire |
| 05. Protecting Tube | : | |
| a) O.D. | : | 8 mm |
| b) Material | : | SS-316, Seamless |
| c) Filling | : | Magnesium oxide (Purity above 99.4%). |
| 06. Calibration | : | DIN 43760 Class A |
| 07. Characteristics | : | Linear with respect to temperature within $\pm 1/2\%$ of top range value |
| 08. Head : | | |
| a) Type | : | IP-65 universal screwed type. (Explosion proof for NEC Class-1, Division 1 area) |
| b) Material | : | Epoxy coated Die cast aluminum or better |
| c) Terminal blocks | : | Nickel plated Brass-screw type / silver plated |





**Tender Specification
for
FGD Package**

**NLC Tamil Nadu Power Ltd.
2x500 MW Project
Tuticorin, Tamil Nadu**

- d) Cable connection : ½” NPT gland and grommet.
- e) Instrument connection to well : ½” NPT
- f) Others : Terminal head cover with SS chain and suitable gasket
09. Accessories : a) Adjustable nipple-union-nipple [1/2” Sch 80 X ½” NPT (M)] with thermowell connection
- b) Compression fittings/unions
- c) Flanges etc. (for flanged connections only)
- d) Forged/bar stock thermowell as per ASME PTC 19.3 code. Process connection M33X2 (M).
- e) Material of construction of Thermowell:
SS 316: In general
10. Nameplate : Tag number, service engraved in stainless steel tag plate

Notes: The specifications for RTDs of winding/ bearings of motor/ pump can be as per their manufacturer standards. The manufacturer shall submit the adequate supporting documents for establishing their standard practice. However, the type of RTD shall be PT100.

1.12.00 Field Mounted Temperature Transmitters

01. Working Principle : Smart
02. Type : Two wire
03. Input : Thermocouple K and RTD (Pt 100)-3/4 wire
04. Isolation : 500V AC
05. Output Signal : Simultaneous transmission of digital and 4-20 mA DC signal. HART protocol.
06. Signal Processing Circuitry : Microprocessor based Solid State Electronic





**Tender Specification
for
FGD Package**

**NLC Tamil Nadu Power Ltd.
2x500 MW Project
Tuticorin, Tamil Nadu**

- | | | |
|-------------------------------|---|--|
| 07. Span and Zero | : | Adjustable in field, Non-interacting facility for elevation and suppression of zero. |
| 08. Enclosure Class | : | IP-65 (Explosion proof for NEC Class-1, Division 1 area) |
| 09. Output Indicator | : | LCD type |
| 10. Span Adjustability | : | Yes |
| 11. Nameplate | : | Tag number to be engraved on metallic tag plate rigidly fixed to the body. |
| 12. Body | : | Die Cast aluminum |
| 13. Operating Voltage | : | 16-48 V dc |
| 14. Load | : | 600 Ohms at 24V DC (Min.) |
| 15. Performance | : | |
| a) Accuracy | : | 0.4% of span |
| b) Repeatability | : | ±0.05% of span |
| c) Cold Junction Compensation | : | Built-in |
| d) Calibration | : | As per N.I.S.T Monograph 125 for T/C and European Curve Alpha = 0.00385 for RTD |
| 16. Accessories | : | a) Universal mounting bracket suitable for pipe and surface mounting. |
| | | b) Hi-tensile Carbon Steel U-bolts. |
| | | c) ½" NPT cable gland |

1.13.00 Temperature Switch

- | | | |
|-------------------------|---|--------------------------------|
| 01. Type | : | Bimetallic / gas filled-in |
| 02. Stem /Bulb Material | : | AISI SS-316 |
| 03. Capillary | : | SS Capillary & Flexible armour |





**Tender Specification
for
FGD Package**

**NLC Tamil Nadu Power Ltd.
2x500 MW Project
Tuticorin, Tamil Nadu**

- | | | | |
|-----|-----------------------|---|--|
| 04. | Case material | : | Epoxy coated die-cast aluminum alloy with neoprene gasket conforming to IP-65. (Explosion proof for NEC Class-1, Division 1 area). |
| 05. | Over range Protection | : | 120% |
| 06. | Instrument connection | : | Bottom |
| 07. | Setter Scale | : | Black graduation on white linear scale. Graduation 0-100% with red pointer for set points. |
| 08. | Switch configuration | : | One DPDT (Two SPDT) |
| 09. | Switch rating | : | 240V, 5A AC/220V, 0.5A DC |
| 10. | Switch type | : | Snap acting, shock and vibration-proof. |
| 11. | Adjustability | : | Internal Set point adjustable over span |
| 12. | Cable connection | : | ½" NPT conduit connection or compression gland. |
| 13. | Compensation | : | a) Capillary compensation with invar wire throughout the capillary length.
b) Case compensation |
| 14. | Performance : | | |
| | a) Repeatability | : | < 1 % of full range |
| 15. | Capillary length | : | 3 meters (minimum) |
| 16. | Nameplate | : | Tag number, service engraved in stainless steel tag plate |
| 17. | Accessories | : | a) Forged thermowell, Mounting accessories,
b) ½" NPT cable gland.
c) Material of construction of Thermowell:
SS 316 : In general
Standard : ASME PTC 19.3 |

1.14.00 Not used.



Development Consultants Pvt. Ltd

**Vol. II-E/Section-III
Instrumentation & Control
For FGD Plant**



**Tender Specification
for
FGD Package**

**NLC Tamil Nadu Power Ltd.
2x500 MW Project
Tuticorin, Tamil Nadu**

- Double acting 7.2 SCFM at 2.1 bar supply
06. Housing : IP 65
07. Repeatability : +/- 0.3% of span or better
08. Accuracy : +/- 0.1% of span or better
09. Communication : Hart protocol
10. Power-up with position control : < 150 ms or better
11. Power interruption without Reset : <100ms or better
12. Body Material : Aluminium
13. Response Time : Less than 10 sec
14. Features :
- i) Noncontact position feedback sensor
 - ii) Integral Electro-Pneumatic convertor
 - iii) Self calibration with tunable response time
 - iv) Online diagnostics
 - v) Pressure gauges to be provided on positioner (I/P & O/P pressure)

1.15.05 Solenoid Valve

01. Operating Principle : Electromagnetic (noiseless)
02. Coil voltage rating : 24V DC (in general) other 220V DC /240V AC /110V AC as per manufacturer recommendation.
03. Ways : 3 ways in general other depending on requirement
04. Port size : 1/4" NPT all ports
05. Body : SS Bar Stock
06. Trim : AISI SS-316





**Tender Specification
for
FGD Package**

**NLC Tamil Nadu Power Ltd.
2x500 MW Project
Tuticorin, Tamil Nadu**

- | | | | |
|-----|-------------------|---|--|
| 07. | Manual Operator | : | In built |
| 08. | Duty | : | Suitable for continuous energization |
| 09. | Sealing | : | Airtight and leak proof |
| 10. | Fluid Temperature | : | 0-150 O C (approx.) |
| 11. | Coil Enclosure | : | Stainless Steel |
| 12. | Insulation | : | Class-H |
| 13. | Coil Casing | : | IP-65 (Explosion proof for NEC Class-1, Division-1 area) |
| 14. | Mounting | : | On pipe or on panel |
| 15. | Cable Connection | : | ½" NPT cable gland |
| 16. | Accessories | : | Mounting brackets, nuts and bolts as required. |
| 17. | Special feature | : | a) LED indication
b) Double coil type. |

1.15.06 Air Lock Relay

- | | | | |
|-----|----------------------|---|--|
| 01. | Type | : | Single acting with actuator (spring return) and double acting with double acting piston cylinder |
| 02. | Max. supply Pressure | : | 7 kg/cm ² |
| 03. | Set Pressure | : | 1.4 ~ 7 kg/cm ² |
| 04. | Ambient Temperature | : | -5 to 60°C |
| 05. | Port Size | : | ¼" NPT(F) |

1.15.07 Position Limit Switch

- | | | | |
|-----|-------------------|---|----------------|
| 01. | Type | : | Proximity type |
| 02. | Temperature Range | : | -25 to 85°C |
| 03. | Protection Class | : | IP-65 |





2.00.00 **CONTROL PANEL / DESK MOUNTED INSTRUMENTS AND ELECTRICAL SYSTEM ACCESSORIES (As applicable)**

2.01.00 **Push Button**

01. Type : Shrouded square format
02. Face Dimension : 32 x 32 mm (maximum)
03. Contact Configuration : 2 NO + 2 NC
04. Contact Addition : Add-on block up to 4 each with 2 pairs of contacts
05. Contact Material : Hard Silver Alloy
06. Contact Rating : 500V / 10 A
07. Utilization Category : AC11 / DC11
08. Insulation Voltage : 2 KV for 1 minute between terminals and earth
09. Mechanical Life : 1 million operations
10. Construction : Aluminum shrouding with plastic lens
11. Colors : Red, Green, Yellow, Black, etc.
12. Connection : Screw terminals
13. Enclosure Class : IP-52
14. Legend : Engraving

2.02.00 **Illuminated Push Button**

01. Type : Square format
02. Face Dimension : 32 x 32 mm (maximum)
03. Contact Configuration : 2 NO + 2 NC (minimum)
04. Contact Addition : Add-on-Block up to 4 each with 2 pairs of contacts
05. Contact Material : Hard Silver Alloy
06. Contact Rating : 500 V/ 10A





**Tender Specification
for
FGD Package**

**NLC Tamil Nadu Power Ltd.
2x500 MW Project
Tuticorin, Tamil Nadu**

- | | | | |
|-----|----------------------|---|---|
| 07. | Utilization Category | : | A C11 / DC11 |
| 08. | Insulation Voltage | : | 2 KV for 1 minute between terminals and earth |
| 09. | Mechanical Life | : | 1 Million Operations |
| 10. | Lamp | : | LED with built-in resistors as required |
| 11. | Lamp Rating :- | | |
| | a) Voltage | : | 240 V AC /24V DC |
| | b) Watt | : | 0.5 Watt (approx) |
| 12. | Lamp and Lens | | |
| | Replacement | : | From front |
| 13. | Construction | : | Transparent Plastic Lens |
| 14. | Color | : | Red, Green, Amber, Yellow etc. |
| 15. | Connection | : | Screw terminals |
| 16. | Enclosure Class | : | IP-52 |
| 17. | Legend | : | Engraving |
| 18. | MTBF lamp | : | 100000 hours |

2.03.00 Selector Switch

- | | | | |
|-----|-----------------------|---|--|
| 01. | Type | : | 2/3/4 position stay put type with rotary lever actuator. |
| 02. | Face Dimension | : | 32 x 32 mm (maximum) |
| 03. | Contact Configuration | : | 4 pair of contacts |
| 04. | Contact Addition | : | Add-on-Block up to 4 each with 2 pairs of contact |
| 05. | Contact Material | : | Hard silver Alloy |
| 06. | Contact Rating | : | 500 V/10 A |
| 07. | Utilization Category | : | AC11 / DC11 |
| 08. | Insulation Voltage | : | 2 KV for 1 minute between terminals and earth |





**Tender Specification
for
FGD Package**

**NLC Tamil Nadu Power Ltd.
2x500 MW Project
Tuticorin, Tamil Nadu**

- 09. Mechanical Life : 1 million operations
- 10. Construction : Aluminum shrouding
- 11. Connection : Screw terminals
- 12. Enclosure Class : IP-52

2.04.00 Indicating Lamp

- 01. Type : LED with built-in resistor
- 02. Face Dimension : 32 x 32 mm (maximum)
- 03. Voltage : 240 V AC / 24V DC
- 04. Watt : 0.5 Watt (approximate)
- 05. Lamp and Lens Replacement : From front
- 06. Construction : Transparent Plastic lens
- 07. Color : Red, Green, Amber, Yellow etc.
- 08. Connection : Screw terminals
- 09. Legend : Engraving
- 10. MTBF : 100000 hours

3.00.00 CONTROL VALVES, ACTUATORS & ACCESSORIES

3.01.00 General Requirements

3.01.01 Control Valves and accessories furnished by the Bidder shall be designed and tested in accordance with the latest applicable requirements of code for pressure piping ANSI B 31.1, ASME Boiler and pressure vessel code, Indian Boiler Regulation (IBR), ISA and other standards as specified elsewhere as well as in accordance with the applicable requirements of the "Federal Occupational Safety and Health Standards, USA" or acceptable equal standards.

All the control valves, their actuators and accessories to be furnished under this section shall be fully suitable and compatible with the services covered under the specification.

3.02.00 Control Valve Sizing and Construction



Development Consultants Pvt. Ltd.

**Vol. II-E/Section-III
Instrumentation & Control
For FGD Plant**



**Tender Specification
for
FGD Package**

**NLC Tamil Nadu Power Ltd.
2x500 MW Project
Tuticorin, Tamil Nadu**

CONTROL DESK/PANEL

- a) All control desks, panels, system cabinets, local panels and local instrument enclosures, racks shall be furnished fully wired with necessary provision for convenience outlets, internal lighting, grounding, ventilation, space heating, anti-vibration pads, internal piping, detachable lifting hook and accessories as per IS:5039-1969 as required for completeness of the system.
- b) Convenient and logical approach to operational interfaces and to enhance aesthetics in the overall view of the panel / desk shall be considered.
- c) All panels, desks, cabinets shall be free standing type and have bottom entry for cables unless otherwise specified. The bottom of desks, panels, cabinets, enclosures shall be sealed with bottom plate, compression cable glands and fire proof sealing material to prevent ingress of dust and propagation of fire. Thickness of gland plate shall not be less than 3 mm.
- d) Panels and cabinets shall be constructed from steel sheet reinforced as required to provide true surface and adequate support for devices mounted thereon. Thickness of the steel plate shall conform to the requirements of UL 50 or equivalent standard. Panels and cabinets shall be of adequate strength to support mounted components and to support a concentrated load of 100 Kilograms on their top after erection.
- e) For items susceptible to vibration, suitable rubber gaskets or padding shall be provided to prevent damage or malfunction.
- f) All electronic system cabinets shall be designed for 50°C operating under maximum ambient temperature without air conditioning system in service. Further cabinets, panels shall be so designed that temperature rise due to heat load does not exceed 10°C above ambient temperature under all operating conditions. Necessary louvers, fans, limited packing density, adequate spacing between instruments, devices etc. shall be provided to maintain temperature rise within permissible limits.
- g) Desk, panels, cabinets enclosures wiring and piping shall be arranged to enable the removal of instruments and devices without unduly disturbing them.
- h) All panels, desks, enclosures interiors shall be illuminated with rapid start fluorescent strip fixtures with door actuated switches. Door switch terminals shall be shrouded. All illuminated lights shall be provided with individual switch in parallel with door switch.
- i) Sufficient number of power receptacles with disconnect switches shall be installed within panels, desks, enclosure and racks.





**Tender Specification
for
FGD Package**

**NLC Tamil Nadu Power Ltd.
2x500 MW Project
Tuticorin, Tamil Nadu**

- j) The local instrument enclosures / racks shall be provided locally for mounting of electronic transmitters and switches, etc.
- k) All panels, desks, cabinets shall be properly grounded. The grounding scheme shall be as approved by the Owner / Consultant.
- l) Exterior steel surface shall be sand blasted, ground smooth, filled, primed, sanded and smooth enamel painted to give a good finish subject to minimum paint thickness of 65-75 microns for sheet thickness of 3 mm and 50 microns for sheet thickness of 2mm. Minimum 2 coats of primer and two sprays of final finish colour shall be applied to all surfaces.
- m) The colour of the panels shall be glossy white with fire resistant paint in the panel interior. External colour of the panels shall be as light grey RAL 7032 for other system cabinets, etc.
- n) Panel / cabinet shall have detachable type eyebolt on top for lifting.
- o) Panel shall be provided with three point latch and lock.
- p) Pocket shall be provided on the inner side of panel doors for keeping drawings & documents.
- q) Nameplates on the panel and terminal blocks shall be provided.
- r) All items like MCB, Terminals, instruments, lamps etc. inside the panels / cabinets shall be neatly arranged with easy access/ maintenance approach to avoid undue disturbing the wiring.
- s) Power supply feeders shall be double so that a single failure shall not affect the operation of the system. Required isolation & protection through MCB shall be provided in all cases. Alarm shall be provided against failure of a single power supply.
- t) Crating of the panels and desks shall be suitable for protection against shock, vibration, inappropriate handling and inclement weather conditions during transportation and warehousing. All panel mounted equipment shall have adequate protection against damage during handling, transit and storage. Suitable desiccant shall be used inside the packing case.

4.02.00 **Surface Preparation and Painting**

All sheet metal panel/ desk exterior steel surfaces shall be sand blasted, ground smooth and painted as specified below:





**Tender Specification
for
FGD Package**

**NLC Tamil Nadu Power Ltd.
2x500 MW Project
Tuticorin, Tamil Nadu**

- a) Suitable filler shall be applied to all pits, blemishes and voids in the surface. The filler shall be sanded so that surfaces are level and flat; corners are smooth and even. Exposed raw metal edges shall be ground burr-free. The entire surface shall be blast clean to remove rust and scale and all other residue due to the fabrication operation. Oil, grease and salts etc. shall be removed from the panels by one or more solvent cleaning methods prior to blasting.

Two spray coats of epoxy primer shall be applied to all exterior and interior surfaces, each coat of primer shall be of dry film thickness of 1.5 mil. A minimum of two spray coats of final finish color (Catalyzed epoxy or polyurethane) shall be applied to all surface of dry film thickness 2.0 Mil.

- b) Paint films, which show sags, cheeks, blisters, teardrops, fat edges or other painting imperfections, shall not be acceptable.
- c) Colour shade for the control desk shall be finalized during detailed engineering.

4.03.00

Wiring

All control and instrument wiring used within the panels shall conform to NEC standards and shall be factory installed and tested at the works. All interior wiring shall be installed neatly. Features shall not be limited to the following:

- a) All spare contacts of relays, switches and push buttons shall be wired up to the terminal blocks. All interconnections between sections of panels / desks shall be furnished.
- b) Each wire shall be identified at both ends with wire designation as per approved wiring diagram. Heat shrinkable type ferrules with indelible computerized print shall be used with cross- identification.
- c) All wire termination shall be made with insulated sleeve and crimping type lugs. All external connections shall be made with one wire per terminal. Wire shall not be spliced or tapped between terminals. Wires shall not be looped around the terminal screws or studs.
- d) Internal wiring should be terminated uniformly on one side of the terminal block leaving the other side available for termination of outgoing cables.
- e) Thermocouple lead wires, analyzer measuring lead wires, or any other lead wires carrying measuring signal of the order of low milli volt or micro volt or mA shall be electrically and physically isolated from other high voltage AC and DC wiring.





**Tender Specification
for
FGD Package**

**NLC Tamil Nadu Power Ltd.
2x500 MW Project
Tuticorin, Tamil Nadu**

- f) Wires shall be dressed and run in trays or troughs with clamp-on type covers. Wirings may be neatly bunched in groups by non-metallic cleats or bands. Each group shall be adequately supported along its run to prevent sagging or strain on termination.
- g) Where pre-fabricated cables are used for direct connection to electronic cubicles plug-in type connectors shall be used.
- h) Shield wires of field signal cables shall be terminated on separate earthed terminals at panel end.
- i) Wiring to door mounted devices shall be provided with multi-strand wires of (49 strands minimum) adequate loop lengths of hinge-wire so that multiple door openings shall not cause fatigue failure of the conductor.
- j) Wiring shall be arranged to enable instruments or devices to be removed and/or serviced without unduly disturbing the wiring. No wire shall be routed across the face or rear of any device in a manner, which shall impede the opening of covers or obstruct access to leads, terminals or devices.
- k) Panel internal wiring shall follow distinct color-coding to segregate different voltage levels viz. 24V DC, 110V AC, 240V AC, 220V DC etc.
- l) Wire shall be multi-stranded annealed flexible high purity copper conductor with heat resistant FRLS PVC insulation and shall pass vertical flame test per IPCEAS-1981.
- m) Conductor sizes used for internal wiring shall not be lower than the followings:
 - i) Power supply / receptacle : 2.5 sq. mm or higher as per load.
/ illumination wiring
 - ii) 4-20mA DC current : 0.5 Sq. mm
and low voltage signal
upto 48V DC
- n) Identification of conductors shall be done by insulation color-coding identified on drawings or by printed wiring lists.
- o) 20% spare conductor shall be provided in the field cable for future use.

4.04.00

Grounding

Development Consultants Pvt. Ltd.

**Vol. II-E/Section-III
Instrumentation & Control
For FGD Plant**



**Tender Specification
for
FGD Package**

**NLC Tamil Nadu Power Ltd.
2x500 MW Project
Tuticorin, Tamil Nadu**

- a) System cabinet AC and DC ground shall be electrically isolated from each other and also electrically isolated from the Instrumentation signal ground. All the above ground shall be individually connected to the single point on the ground pit. Dedicated redundant earth pit shall be provided which shall be away from the HV equipment. This earth pit shall not be shared with other electrical equipment ground and shall also be insulated from other electrical system ground to ensure single point grounding of the system. Grounding resistance shall be better than 1.0 ohm. IEEE guideline shall be followed while designing the grounding system.
- b) All panels and cabinets shall be provided with a continuous tinned copper ground bus bar of minimum 25 mm x 6 mm cross section, extending along the entire length of the panel / desk / cabinet assembly. This signal ground bus shall be bolted to the panel structure on the insulated post. All shield wires shall be connected to this bus for onward connection to the earth pit. System DC power ground shall also be connected to the earth pit in similar way.
- c) The panel /desk /enclosure /JB ground shall have two (2) bolt drilling with GI bolts and nuts at each end to connect to GI / copper flat ground riser or by means of insulated copper ground cable of required cross section with lug for protection ground.
- d) Each circuit requiring grounding shall be individually and directly connected to the panel ground bus.
- e) Signal cable shields shall be grounded at the panel end only and shall never be left open. The ground in between panels of a shipping section shall be firmly looped.
- f) Manufacturer recommendation and scheme shall be followed for all system panel grounding.
- g) Electrical transmitters and switching devices, operating at a voltage less than 50V shall be grounded through the steel structure.

4.05.00 Miniature Circuit Breakers (MCB)

MCB shall be used for protection and isolation of logic circuit and power distribution circuit.

4.06.00 Fuse Blocks

Where fuse blocks are required by the specifications or the manufacturer's design, they shall be modular type with bakelite frame and reinforced retaining clips. Blocks shall be class H.2 pole, screw terminal fuse blocks. Blocks for other current and voltage ratings shall be similar in construction.

4.07.00 Fuses



Development Consultants Pvt. Ltd.

**Vol. II-E/Section-III
Instrumentation & Control
For FGD Plant**



**Tender Specification
for
FGD Package**

**NLC Tamil Nadu Power Ltd.
2x500 MW Project
Tuticorin, Tamil Nadu**

Where slow blow fuses are required for protection of instruments /devices they shall have ampere ratings of 1/4, 1/2, 1 or 2. Where fast acting fuses are required for protection of equipment they shall have ampere ratings of 1, 3, 6, 10, 15, 20 or 30. Indicating fuses or blocks to quickly identify a failed fuse shall be provided to the extent possible.

4.08.00

Terminal Blocks

- a) Terminals shall be chromated galvanized DIN rail mounted screw less cage clamp type. Terminals shall have screwed connection for conductor cross-section above 2.5 mm². Terminal blocks shall conform to IEC 947-7-1.
- b) The characteristics of the terminal blocks shall be as follows.
 - i) High contact force, independent of conductor cross-section and large contact surface area.
 - ii) Integrated self-loosening protection to avoid shifting of contact surface that may allow contamination of connection point.
 - iii) Inspection and maintenance free (resistant to thermal aging and vibration)
 - iv) Low and constant voltage drop
- c) Material of the clamping yoke of screwed terminals shall be electroplated, chromated, case hardened steel with high strength clamping screw. For screw less terminals, the tension spring shall be made of high quality, non-rusting, acid-resistant steel. The current bar shall be of tin-lead plated copper or brass.
- d) Terminals shall be of non-flammable suitable thermoplastic material such as polyamide.
- e) Terminal blocks shall be mounted vertically in panels and cubicles with clearance for at least 100 mm between two sets and between wall and terminal block. Bottom of the terminal block shall be at least 200 mm above the cable gland plate for bottom entry type panels.
- f) Terminal blocks shall be provided with white marking strips / self-adhesive marker cards. Power terminals shall have protection covers.
- g) At least 20 percent spare unwired terminals shall be provided for all panels /cabinets /desks /junction box etc. This shall be in addition to spare wired terminals of spare IO channels and wired spare modules.
- h) For extending 24 V DC supply to panels, the size of the terminals shall be decided based on voltage drop and not based on current.





**Tender Specification
for
FGD Package**

**NLC Tamil Nadu Power Ltd.
2x500 MW Project
Tuticorin, Tamil Nadu**

- i) The last terminal in a rail-mounted assembly shall be closed with an end plate and end bracket.
- j) For visual and electrical separation of terminal groups, partition plates shall be provided, which can be push fitted after forming an assembly.
- k) The terminals for DCS / PLC input /output connections to SWGR / MCC, actuator starter, solenoid valves etc. shall be provided with built in test and disconnect facilities to permit testing of incoming and outgoing signals by using suitable test plug and socket without disconnecting the cable connections. Technical detail for the same shall be finalized during detailed engineering.
- l) It shall also be possible to use jumper plugs through the above test plug socket to connect adjacent terminals. Adequate number of short circuit jumper plugs shall be provided for the purpose.
- m) Where more than one connection to a terminal block is required, two tier terminals shall be used.
- n) Terminal blocks shall preferably be assigned different colors depending upon voltage and current levels.

4.09.00 Nameplates and Labels

- a) Nameplate shall be furnished for each instrument or device mounted on the panel / desk.
- b) The material shall be laminated phenolic, 3 mm thick with white letters on black background.
- c) The nameplates for panels / consoles shall be provided both on the front and the rear.
- d) Nameplates for all devices shall be located adjacent to the respective devices.
- e) All such nameplates, instruction plates, lubrication charts etc. shall be with English inscriptions.

4.10.00 Wiring Diagram

Each panel & enclosure shall have drawing pockets to store the relevant drawings of the respective panels. For the junction box printed wiring schedule engraved in black on white bakelite sheet shall be suitably affixed inside the junction box.

4.11.00 Control Desks





**Tender Specification
for
FGD Package**

**NLC Tamil Nadu Power Ltd.
2x500 MW Project
Tuticorin, Tamil Nadu**

- 4.11.01 All devices mounted on the panel / desks shall be flush type. Instruments / devices shall be so mounted that the removal and replacement can be accomplished individually without interruption of services to others.
- 4.11.02 Desk shall be ergonomically designed to suit the user / operators needs on a 24 x 7 basis. Aesthetic, ergonomics and lighting shall be considered while positioning of the desk, large video screen and panels in control room.
- 4.11.03 Control desk shall be free standing floor mounting type tabletop design with compartments for locating the computers and other hardware. Desk shall be of latest technology aesthetic design and constructed from aluminium extrusion with high pressure laminate 25 mm thick MDF board for work surface as per Owner / Consultant's approved colour. Aluminium structure shall be anodized or powder coated paint finish.
- 4.11.04 Desk should have concealed cable trays and wire management system, which shall be easily accessible for maintenance. The cable management should be designed to support vertical and horizontal cables with proper hardware and accessibility. Cable tray shall be designed from steel with powder coated paint finish.
- 4.11.05 Design shall include earthing bolts on left side end and right side end of the Desk.
- 4.11.06 Crating of the desks shall be suitable for protection against shock, vibration, inappropriate handling and inclement weather conditions during transportation and warehousing and all panel mounted equipment shall have adequate protection against damage during handling, transit and storage. Suitable desiccant shall be used inside the packing case.
- 4.11.07 OWS and other application terminals mounted on the control desk shall be powered from UPS feeders and each feeders shall be provided with MCB at the upstream of the permanent Power receptacles. A minimum of two set of Alarm Accept/Reset Push Button shall be provided on each Control Desk.
- 4.11.08 The desks shall be complete with vibration dampener and foot leveler.
- 4.11.09 **Technical Specification of Control Desk**
- i) The frame / structure should be minimum 2mm thick Powder Coated Extruded Aluminum profile.
 - ii) The Table Top / Work Surface shall be 36mm thick, Medium Density Fiber (MDF) board with high pressure laminate or Acrylic Plastic Solid Surface (APSS). Top surface shall be finished with anti-scratch material.
 - iii) Foot extension shall be of Cast Aluminum & painted.





**Tender Specification
for
FGD Package**

**NLC Tamil Nadu Power Ltd.
2x500 MW Project
Tuticorin, Tamil Nadu**

- iv) Foot Leveler shall be injection molded glass filled nylon foot with steel insert.
- v) END Caps & Extruded PVC Caps shall be provided where required.
- vi) Front edge shall be extruded PVC or rounded post-formed laminate.
- vii) Concealed cable tray shall be powder coated steel.
- viii) Provision shall be made for keeping Multi-media speakers.
- ix) Design shall include Earthing bolts on left side end and right side end of the Workstation Desk / Rack.
- x) Design should include cutouts for Push buttons, Public Address System and Function Keyboard mounting on the Furniture.
- xi) Retractable keyboard tray in the control desk shall be provided.
- xii) Retractable tray with telescopic slide for CPU/PC block shall be provided.
- xiii) Front and Rear door shall be considered.

4.12.00 Not used.

4.13.00 **System Cabinets / Panels**

- 01. Material of construction : Cold rolled steel sheet
- 02. Thickness of Sheet : 2 mm thickness for load bearing and 1.6mm for non-load bearing.
- 03. Construction : Welded throughout as per (metallic parts) approved National Standards.
- 04. Panel height : 2300 mm (approx.)
- 05. Doors : Full height front & rear door, recessed, turned back edges. Double door for panel width more than 800 mm.
 - a) Thickness of Sheet : 2 mm
 - b) Hinges : Concealed stainless steel type





**Tender Specification
for
FGD Package**

**NLC Tamil Nadu Power Ltd.
2x500 MW Project
Tuticorin, Tamil Nadu**

- | | | | |
|-----|----------------------|---|--|
| c) | Door latches | : | Three point type |
| d) | Door gaskets | : | Neoprene rubber on fixed frame to result dust proof / weather proof enclosure. |
| e) | Opening of the doors | : | Outward |
| f) | Louvers | : | With removable wire mesh to ensure dust and vermin proof. |
| 06. | Colour of interior | : | Glossy white |
| 07. | Colour external | : | Light grey RAL 7032 |
| 08. | Painting | : | Epoxy powder coated or better |
| 09. | Gland plates | : | Removable 3 mm thick (bottom) |
| 10. | Cable entry | : | Bottom |
| 11. | Hardware | : | <ul style="list-style-type: none"> a) Anti vibration pad- 15 mm b) Predrilled base channel ISMC - 100 or equivalent for all sides. c) Stainless steel buff- finished 2 mm thick kick plate for all sides. d) Stainless steel scratch strips along desk edges fixed with pan-head recessed screws. e) Rubber strips to ensure air tightness between kick plate and finished floor. f) Detachable lifting hook / Eye bolt g) Drawing pocket at front & rear door h) Door switch, lamps, thermostat, heaters and fans i) Door lock with master key |

4.14.00

Furniture

Bidder shall provide following industrial grade furniture items as a minimum from reputed manufacturers/suppliers meeting International Standards. The furniture shall be modular and latest with ease of operational features. The furniture shall be modern, aesthetically designed, modular, flexible, space saving and future safe.





**Tender Specification
for
FGD Package**

**NLC Tamil Nadu Power Ltd.
2x500 MW Project
Tuticorin, Tamil Nadu**

4.14.01 Workstation Furniture

Modular work station furniture, suitable for mounting servers & historians, programmer stations, PC based systems, printers (A4/A3 color laserjet) etc. shall be provided.

4.14.02 PC Rack

PC Racks shall be provided to mount CPUs of workstations/ PCs of OWS/LVS etc. in control room. For each PC / workstation / monitor at least one chair shall be included.

4.14.03 Chairs

Industry standard revolving chairs with wheels and with provision for adjustment of height (hydraulically/gas lift) shall be provided for the operators, unit-in-charge & other personnel in control room area. These shall be designed for sitting for long duration such that these are comfortable for the back.

4.15.00 Local Instrument Enclosure (Closed type enclosure shall be provided in all areas)

4.15.01 Transmitters, switches and devices located in the field shall be grouped together and shall be installed in the Enclosure in case of outdoor area such as Boiler area etc. and in Open Type Rack in case of covered area. Racks and enclosure shall be factory prefabricated & painted and complete with internal piping, tubing, manifold valve, isolation valves, blow down valves, integral junction box, wiring, illumination etc. with outside access doors, Racks used for furnace, flue gas and air application shall be provided with intermittent & continuous air purging. No more than six instruments shall be grouped in a single rack /enclosure

4.15.02 The local instrument enclosures shall be constructed from 2.0 mm thick sheet plate and shall be of modular construction with one or more modules and two end assemblies bolted together to form an enclosure. Gaskets shall be used in between all mating sections to achieve protection class of IP-55. Enclosure doors shall have three point lock.

4.15.03 The local instrument racks shall be free standing type constructed from suitable 3 mm thick channel frame of steel and shall be provided with a canopy at top to protect the equipment mounted in racks from falling objects, water etc. The canopy shall not be less than 3 mm thick steel and extended beyond the ends of the rack.





**Tender Specification
for
FGD Package**

**NLC Tamil Nadu Power Ltd.
2x500 MW Project
Tuticorin, Tamil Nadu**

- 4.15.04 Bulk heads, especially designed to provide isolation from process line vibration shall be provided. Bulkhead plates shall be removable type and thickness of not less than 6 mm shall be employed.
- 4.15.05 2" NB galvanized pipes shall be laid horizontally and supported at two end channels to mount transmitters/ switches at accessible height. Adequate support for manifold, impulse pipe and cable tray shall be provided and the same shall be adjustable.
- 4.15.06 All internal wirings and / or data bus connections, if any, between the transmitters and terminal junction box shall run through flexible dust tight conduits connected to the terminal box hub. No exposed wirings within transmitter racks, both open and closed type, is admissible.
- 4.15.07 All racks shall have a common closed drain trough to connect transmitter drain points to a common header after suitable pressure breaking. Covered funnels shall be used for saturated liquid and steam service, whereas, open funnels may be used for cold liquid services. The trough shall be suitably sloped and shall have one end flanged and extending beyond the rack for connection to plant drain header. Individual Instrument blow down line shall be connected to the common blow down drain header through regulating globe type blow down valves. The common blow down drain header shall be 2" NB ASTM A106, Sch-80 Gr. C installed at a slope of 1:25.
- 4.15.08 The junction box for enclosure and racks shall conform to IP 65 protection class. Junction box shall be provided as an integral compartment at one side of the enclosure / rack with front opening type door. Junction box shall be complete with DIN rail mounted terminals, MCB, receptacles and earth bar. All wiring shall be laid in PVC cable tray. Cable gland plate shall be provided for cable entry from bottom. Earth bar shall be made of tinned copper continuous and of 25 X 6 MM size.
- 4.15.09 Each rack shall be provided with receptacle, light fixture with wire guard and lighting switch. Light fixtures shall be installed on the ceilings of rack / enclosure.
- 4.15.10 Type, size and material grade of the impulse pipes, fittings and valves are listed elsewhere in this specification
- 4.15.11 Bidder shall furnish the drawing and documents showing detail arrangement of racks and enclosure and hook up along with instrument grouping at detailing stage for Owner / Consultant's approval.
- 5.00.00 **FGD CONTROL SYSTEM & CEMS**
- 5.01.00 **General Requirements**
- 5.01.01 FGD system automation shall be realized in a dedicated hot redundant Programmable Logic Control (PLC) based control system.



PH Analyser

1. Type	Cell - flow through
2. Accuracy	< ± 1% of span
3. Range	0 - 14 pH, programmable
4. No. of streams	Single
5. Stability	< 0.001 pH / week
6. Temp. Coefficient / Temp. error	0.001 pH / Deg. C
7. Type of electronics	Microprocessor based with self-diagnostic Facility.
8. Indication	Digital
9. Enclosure	Weather dust proof (IP55) Die cast aluminum.

Dew point meter

Sensor

Type	:	Capacitance type with change in output proportional to moisture present.
Service	:	Dry Air
Range	:	-50 to 0 Degree Centigrade Dew-Point
Sensor Accuracy	:	Better than +/-0.5^
Operating Temperature	:	0 to 50 degree C.
Operating Pressure	:	0-10 Kg./Cm2, suitable for process application.

Analyser

Input	:	Change in capacitance from dew point sensor.
Display	:	Combined enclosure with two three-digit seven segments LED display with decimal point after two digits. LED height shall be 4 inches, clearly legible from a distance of atleast 10 meters.
Range	:	-50 to 0 Degree Centigrade Dew-Point
Display Accuracy	:	Better than +/-2 Degree C.
Mounting	:	Table top/Flush mounting, to be finalised during

- Power supply : 240V AC, 50 Hz to be arranged by the contractor.
- Output : 5-20 mA DC capable of driving a load impedance of 500 ohms minimum.

4-20 mA DC Output signal is to be connected to control system in Contractor's Scope (Interconnection cables are to be provided by the Contractor).

In case the system is not suitable for Direct online mounting, then all the required sampling system is to be provided by the contractor.

All required accessories including cables, sensor holder, desiccant chambers, mounting fixtures etc. are to be supplied by the Contractor within his quoted lumpsum price.

Conductivity Monitors

Specific conductance cell	
Specific conductance cell shall be provided with suitable electrode material and cell body material taking into account the various factors of actual service conditions, corrosion resistance etc. Cell constant shall be subject to Owner's approval, the cell shall be provided with automatic temperature compensation. The specific conductance cell shall be suitable for use in the plant discharge water.	
Conductivity cells are shall be compatible with the conductivity monitors.	
The monitor shall have the following design features :	
a)	Power supply : 240V AC 50, Hz single phase/ 24 V DC
b)	Range : 0-1, 0-10, 0-100, 0- 1000, 0- 10,000 micro mho/cm programmable. 0-2500 ppm for dissolved solids.
c)	Signal accuracy excluding meter accuracy : Approximately 1% of full scale
d)	Temperature compensation : Automatic
e)	Response time : <=1 sec.
f)	Identification : Phenolic nameplate stating monitor number, sample and conductivity cell number.
g)	Output : 4-20 mA DC buffered output capable of driving a minimum load impedance of 500 Ohms.
Analysers, monitors shall be microprocessor based.	
The monitor shall be of multi-range type, single range monitor shall not be acceptable.	



**Tender Specification
for
FGD Package**

**NLC Tamil Nadu Power Ltd.
2x500 MW Project
Tuticorin, Tamil Nadu**

- ii) Double locknuts shall be provided on all conduit terminations not provided with threaded lugs and couplings. Locknuts shall be designed to securely bond the conduit to the enclosure when tightened. Locknuts shall not loosen due to vibration.
- iii) Conduit supports shall be furnished and installed in accordance with the specifications.

9.01.02

Junction Box

- | | | | |
|-----|--------------------|---|--|
| 01. | Type of Enclosure | : | Dust tight & weatherproof conforming to IP 65 |
| 02. | Material | : | 3 mm sheet steel/ fiberglass reinforced polyester (UV stabilized) |
| 03. | Type of Cover | : | Solid unhinged with retention chain/ screwed at all four corners |
| 04. | Paint | : | RAL 7032 – Siemens Grey |
| 05. | Mounting | : | Surface/ 2" pipe stanchion
(At a dry compartment at one side of the enclosure/ rack with front opening type door) |
| 06. | Cable Entry | : | 3 mm (min) Bottom / side Gland plate |
| 07. | Gasket | : | Neoprene |
| 08. | Grounding | : | Brass earth lug with green screw head
External-two (2) nos., Internal – one (1) no. |
| 09. | No. of Drain holes | : | Two at bottom capped |
| 10. | Identification | : | Label for JB & tags for cable |
| 11. | Accessories | : | a) Rail mounted cage clamp type screw less terminals (suitable for conductor size up to 2.5 sq. mm of suitable voltage grade) with markers and 20% spare terminals.
b) Cable gland (Brass) & raceways |

9.01.03

Cable Gland

- | | | | |
|-----|------|---|--------------------|
| 01. | Type | : | Double compression |
|-----|------|---|--------------------|





**Tender Specification
for
FGD Package**

**NLC Tamil Nadu Power Ltd.
2x500 MW Project
Tuticorin, Tamil Nadu**

02. Entry Thread : NPT
03. Material : Brass
04. Finish : Cadmium Plated.
05. Protection : IP 54 or better
06. Accessories : Neoprene gasket, locknuts, reducers etc.

9.01.04 Cable Tray

01. Material : Mild steel
02. Thickness : not less than 2.0 mm
03. Finish : Hot dip galvanized
04. Perforation : As per MFR standard.
05. Cover : Suitable for tray

9.02.00 Process Hook Up Accessories & Specification (as applicable)

Material and rating of the hook up items shall generally suit the piping and fluid condition. Bidder shall furnish hook up drawings and the drawings for open racks & closed racks for Owner / Consultant's approval. For the design guide line Bidder shall refer to Section-I of this Volume.

9.02.01 Specification for Process Hook Up Materials

Sr. No	System	Piping class	Impulse Pipe Material	Schedule	Materials for Valve / Fittings	Stem Material	Rating of Fitting	Pr. Class of valve
1.	Auxiliary steam	G	ASTM-A106 Gr. B	80 (1/2 inch)	ASTM-A 105	ASTM -A182 Gr. F-6a	3000 lb	800
2.	Air / Flue Gas Outside Furnace	K	ASTM-A106 Gr. B/C	80 (3/4 inch)	ASTM-A 105	ASTM -A182 Gr. F-6a	3000 lb	800
3.	Air / Flue Gas Inside Furnace	L	ASTM-A335 Gr. P-22	80 (3/4 inch)	ASTM-A 182 Gr. F-22	ASTM -A182 Gr. F-6a	3000 lb	800





**Tender Specification
for
FGD Package**

**NLC Tamil Nadu Power Ltd.
2x500 MW Project
Tuticorin, Tamil Nadu**

Sr. No	System	Piping class	Impulse Pipe Material	Schedule	Materials for Valve / Fittings	Stem Material	Rating of Fitting	Pr. Class of valve
4.	DM Cooling Water	M	ASTM A312 TP 316	40 (1/2 inch)	ASTM A182 F316	SS or better	3000 lb	800
5.	Cooling Water	N	ASTM-A106Gr . C	80 (1/2 inch)	ASTM-A 105	SS or better	3000 lb	800

Note:

- 1) Above requirements to be complied by Bidder as applicable for the FGD system. Rating of piping/ fittings / valves etc. is subjected to be approved by Owner as per the final design pressure & temperature finalized during the detail engineering as per ANSI B31.1.
- 2) Material shall be compatible with that of the impulse pipe material and design parameter.
- 3) For DM water services, complete erection hardware material shall be SS316 only.

9.02.02

Seamless Stainless Steel Pipe

01. Reference : ASTM A-312 TP 316
02. Material Grade : TP 316
03. Type : Seamless /Plain end
04. Size : 1/2" NB
05. Schedule : 40
06. Standard Length : 5 meter

9.02.03

Stainless Steel Pipe Fittings

01. Reference : ASTM A-182 F 316 / ANSI B16.11
02. Type : Forged
03. Rating : 3000 lbs / 6000 lbs / 9000 lbs
04. Size : 1/2" NB





in Electrical Volume)

8.25.00 **Instrumentation & Control Cabling**

8.25.01 Instrumentation cables shall be copper, overall screened for binary signals and individual & overall screened for analog signals. All cables shall be FRLS type (inner & outer sheath) and armoured. Inter panel cables inside Control Rooms may be unarmoured. All the unarmoured cables shall run through conduits.

8.25.02 Fiber Optic cables in the field shall be laid through HDPE conduits for buried section and through dedicated encased perforated GI trays for over-ground section.

8.25.03 Bidder to follow the the following philosophy

- 1) DI & DO signal cannot be routed through the same cable.
- 2) Single pair or single triad cable is not acceptable. Minimum of 2 pairs or 2 triad cable shall be used.
- 3) Each multi-pair or multi-triad cable shall have 20% or minimum 1 pair / 1 triad cable whichever is maximum as spare.

8.25.04 Cable size & type shall be as below for different type of signals and control system shall be followed in general.

- 1) Cables for analog signals will be instrumentation paired cable of 0.5 sq. mm copper conductor size, with individual pair shielding & overall shielding.
- 2) Cables for binary signals will be instrumentation paired cable of 0.5 sq. mm copper conductor size with overall shielding only.
- 3) Conductor cross section for triad signal cables will not have individual conductor cross section below 1.5 sq. mm.
- 4) For interposing relay drive connection individual conductor cross section will not be below 1.5 sq. mm.
- 5) Cables for power supply to each solenoid valves will be control cable of 3C x 2.5 sq. mm copper conductor size for all voltage level.

9.00.00 **TYPE TEST**

9.01.00 **General Requirements**

- a) The Bidder shall furnish the type test reports of all type tests as per relevant standards and codes as well as other specific tests indicated in this specification. List of major tests are furnished below for solid state equipment. For the balance systems & instruments, which are not indicated here, type tests may be conducted as per manufactures





standard or if required by relevant standard.

- b) The Bidder / sub-vendor / manufacturer is required to conduct certain type tests specifically for this project as specified in respective sections and to be witnessed by Owner / Consultant or their authorized representative, even if the same had been conducted earlier. In case Owner / Consultant decides to waive any of the Type tests for any item based on tests conducted by Bidder in the last five years, Test certificates for same shall be provided for review / acceptance and the final decision rests with Owner / Consultant.
- c) Submission of type test results and certificate shall be acceptable provided:
 - i) The same has been carried out by the Bidder / sub-vendor on exactly the same model / rating of equipment.
 - ii) There has been no change in the components of offered equipment from tested equipment.
 - iii) The test has been carried out as per the latest standards along with amendments.
- d) In case the approved equipment is different from the one on which the type test had been conducted earlier or any of the above grounds, then the tests have to be repeated and the cost of such tests shall be borne by the Bidder within the quoted price and no extra cost shall be payable by the Owner on this account.
- e) The schedule of conduction of type tests / submission of reports indicating the test standard shall be submitted and finalized during pre-award discussion for Owner / Consultant's review & approval.
- f) For the type tests to be conducted, Bidder shall submit detailed test procedure for approval by Owner / Consultant. This shall clearly specify test setup, instruments to be used, procedure, acceptance norms (wherever applicable), recording of different parameters, interval of recording, precautions to be taken etc. for the tests to be carried out.

9.02.00 **Special requirements for Solid State Equipments & Systems**

The type tests reports, as a minimum, over and above the requirements of above clause which are to be submitted for each of the major C&I system shall be as indicated below:

9.02.01 **Electromagnetic Immunity as per EN 61000-6-22**

- a) Equipment furnished by Bidder shall incorporate necessary techniques to eliminate measurement and control problems caused by electromagnetic interferences especially encountered in power plant





environment. Equipment, which is vulnerable to such interference, shall be suitably immunized to eliminate possible problems.

- b) Required shielding, input balancing, ripple amplitude and grounding for field signals and for the control systems to achieve an installation with minimum noise coupling from all sources.
- c) Any additional equipment, deliverables required for effectively eliminating the noise problems shall be identified and included.
- d) Electromagnetic emission as per EN 61000-6-43

9.02.02 Surge-Protection For Solid State Equipment

All solid state systems / equipment shall be immunized and able to withstand the electrical noise and surges as encountered in actual service conditions inherent in a power plant. All the solid state systems/ equipments shall be provided with all required protections that needs the surge withstand capability as defined in ANSI 37.90a-1989. Hence, all front end cards which receive external signals like analog input & output modules, binary input & output modules etc. including power supply, data highway, data links shall be provided with protections that meet the surge withstand capability as defined in ANSI 37.90a. Complete details of the features incorporated in electronics systems to meet this requirement, the relevant tests carried out, the test certificates etc. shall be submitted along with the proposal. As an alternative to above, IEC / EN 61000-4-4 & IEC / EN 61000-4-5 for Electrical fast transient / burst and Surge immunity may also be adopted for SWC test.

9.02.03 Type Test Requirement for C&I Systems

Sl. No.	Item	Test Requirement	Standard	Test to be specifically conducted	Approval required on Test Certificate	Remarks
1.	Transducers	As per Standard	IEC-688, IS-12784	NO	YES	
2.	Thermocouples	Degree of Protection Test	IS-2147	NO	NO	
3.	RTD	As per Standard	IEC-751	NO	NO	
4.	C.J.C. Box	Degree of Protection Test Ambient Temp. effect	IS-2147 Approved Procedure	NO NO	YES YES	
5.	Electronic Transmitter	As per Standard	BS-6447 / IEC-770	NO	YES	





**Tender Specification
for
FGD Package**

**NLC Tamil Nadu Power Ltd.
2x500 MW Project
Tuticorin, Tamil Nadu**

Sl. No.	Item	Test Requirement	Standard	Test to be specifically conducted	Approval required on Test Certificate	Remarks
6.	E/P Converter	As per Standard	Mfr. Standard	NO	YES	
7.	Dust Emission Monitor	Degree of Protection Test	IS-2147	NO	YES	
8.	Instrumentation Cables Twisted & Shielded			YES	YES	
	a) Conductor	<ul style="list-style-type: none"> • Resistance Test • Diameter Test • Tin Coating Test (drain wire) 	<ul style="list-style-type: none"> VDE-0815 IS-10810 			
	b) Insulation	<ul style="list-style-type: none"> • Loss of mass • Aging in air ovens • Tensile Strength and Elongation • Heat Shock • Hot Deformation • Shrinkage • Bleeding & Blooming 	<ul style="list-style-type: none"> VDE-0472 0472 ** VDE 0472 ** VDE 0472 ** VDE 0472 VDE 0472 IS-5831 			** As per VDE 0207 for Teflon insulated cables
	c) Inner Sheath	<ul style="list-style-type: none"> • Loss of mass • Heat Shock • Cold Bend / Cold Impact Test • Hot Deformation • Shrinkage 	<ul style="list-style-type: none"> VDE-0472 VDE 0472 ** IS-5831 VDE 0472 VDE 0472 			





**Tender Specification
for
FGD Package**

**NLC Tamil Nadu Power Ltd.
2x500 MW Project
Tuticorin, Tamil Nadu**

Sl. No.	Item	Test Requirement	Standard	Test to be specifically conducted	Approval required on Test Certificate	Remarks
	d) Outer Sheath	<ul style="list-style-type: none"> • Loss of mass • Aging in air ovens • Tensile Strength and Elongation Test before and after ageing • Heat Shock • Hot Deformation • Shrinkage • Bleeding & Blooming • Colour Fastness to Water • Cold Bend / Cold Impact Test • Oxygen Index Test • Smoke Density Test • Acid Gas Generation Test 	VDE-0472 VDE 0472 ** VDE 0472 ** VDE 0472 ** VDE 0472 VDE 0472 IS-5831 IS-5831 IS-5831			
	e) Fillers	<ul style="list-style-type: none"> • Oxygen Index Test • Smoke Density Test • Acid Gas Generation Test 	ASTMD-2863 ASTMD-2843 IEC-754-I			
	f) AL-MYLAR Shield	<ul style="list-style-type: none"> • Continuity Test • Shield Thickness • Overlap Test 				
		<ul style="list-style-type: none"> • Noise 	IEEE			





Tender Specification
for
FGD Package

NLC Tamil Nadu Power Ltd.
2x500 MW Project
Tuticorin, Tamil Nadu

Sl. No.	Item	Test Requirement	Standard	Test to be specifically conducted	Approval required on Test Certificate	Remarks
	g) Overall Cable	<ul style="list-style-type: none"> Interference • Flammability • Noise Interference • Dimensional Checks • Cross talk • Mutual Capacitance • HV Test • Drain Wire Continuity 	Transactions IEEE 383 IS 10810 VDE 0472 VDE 0472			
9.	Pressure Gauge	<ul style="list-style-type: none"> • Degree of Protection Test • Temperature Interference Test 	IS-2147 IS-3624	NO NO	NO NO	
10	Temperature Gauge	Degree of Protection Test	IS-2147	NO	NO	
11	Pressure & Differential Pressure Switch	<ul style="list-style-type: none"> • Degree of Protection Test • As per Standard 	IS-2147 BS 6134	NO NO	NO NO	
12	Level Switch	Degree of Protection Test	IS-2147	NO	NO	
13	Conductivity Level Switch	Degree of Protection Test	IS-2147	NO	YES	
14	Control Valves	CV Test	ISA 75.02	YES	NO	
15	Flow Nozzles & Orifice Plate	Calibration	ASME PTC, BS-1042	YES	NO	
16	PLCs	All tests as per IEC-1131	IEC-1131			
17	LIE / LIR / Junction Box	Degree of Protection Test	IS-2147	YES	YES	
18	Flue Gas O ₂	Degree of	IS-2147	NO	YES	



Sl. No.	Item	Test Requirement	Standard	Test to be specifically conducted	Approval required on Test Certificate	Remarks
	Analyzer	Protection Test				
19	Flue Gas SO ₂ Analyzer	Degree of Protection Test	IS-2147	NO	YES	

10.00.00 **TRAINING**

10.01.00 Bidder's experienced personnel / engineers shall provide training courses on offered PLC, VMS or any other special instrument, to Owner's engineers in the following areas:

- a) Operator training
- b) Hardware maintenance training
- c) Software training
- d) Any other specialized training as required for system operation and maintenance

10.02.00 The maintenance training shall include lectures and hands on experience on a similar type of equipment / system at manufacturer's works and / or training simulator. The details of hardware and software training shall be finalized during detailed engineering and shall be subject to Owner's acceptance.



VOLUME: II-F

SECTION III

ELECTRIC MOTOR ACTUATORS

1.00.00 SCOPE

- 1.01.00 This Section covers the general requirements of Electric Motor Actuators for valves, dampers and gates.
- 1.02.00 All electric motor actuators shall be furnished in accordance with this general specification and the accompanying driven equipment specification.

2.00.00 CODES & STANDARDS

- 2.01.00 All equipment and materials shall be designed, manufactured and tested in accordance with the latest applicable Indian Standards (IS), IEC, ANSI & NEMA Standards except when otherwise stated herein or in the driven equipment specification.
- 2.02.00 Equipment and material conforming to any other standards, which ensure equal or better quality, may be accepted. In such case, copies of the English version of the standard adopted shall be submitted along with the bid.
- 2.03.00 The electrical installation shall meet the requirements of Indian Electricity Rules as amended up-to-date and relevant IS Code of Practice. In addition, other rules and regulations applicable to the work shall be followed.

3.00.00 SERVICE CONDITIONS

- 3.01.00 The actuator shall be suitable for operation in hot, humid and tropical atmosphere, highly polluted at places with dust and/or fly ash.
- 3.02.00 Unless otherwise noted, electrical equipment / system design shall be based on the service conditions and auxiliary power supply given in the annexure to this specification.

4.00.00 RATING

- 4.01.00 For isolating service, the actuator shall be rated for three successive open-close operation of the valve / damper or minimum S2-15 minutes.
- 4.02.00 For regulating service, the actuator shall be suitably time-rated for the duty cycle involved with necessary number of starts per hour, but in no case less than 150 starts per hour.





4.03.00 A safety factor of 300% shall be used for sizing of operators for valves and dampers and all drive system components. Operators shall be capable of transmitting design torque (including safety factor) within the torque range specified by the actuator manufacturer. The strength of the operator mounting, based on the required operator torque, shall not exceed 30% of the yield strength in any mode of stress.

5.00.00 PERFORMANCE

The actuator shall meet the following performance requirements:

5.01.00 Open and close the valve completely and make leak-tight valve closure without jamming.

5.02.00 Attain full speed operation before valve load is encountered and impart an unseating blow to start the valve in motion (hammer blow effect).

5.03.00 Operate the valve stem at standard stem speed and shall function against design differential pressure across the valve seat.

5.04.00 The motor reduction gearing shall be sufficient to lock the shaft when the motor is de-energised and prevent drift from torque switch spring pressure.

5.05.00 The entire mechanism shall withstand shock resulting from closing with improper setting of limit switches or from lodging of foreign matter under the valve seat.

6.00.00 SPECIFIC REQUIREMENT

6.01.00 Construction

6.01.01 The actuator shall essentially comprise the drive motor, torque / limit switches, gear train, clutch, hand wheel, position indicator / transmitter, in-built thermostat for over load protection, single phase preventer protection, space heater and internal wiring. Actuator shall be integral type. Two sets of torque and limit switches shall be provided to use in PLC logic and electrical logic/ interlock independently.

6.01.02 The actuator enclosure shall be totally enclosed IPW-67, dust tight, weather-proof suitable for outdoor use without necessity of any canopy.

6.01.03 All electrical equipment, accessories and wiring shall be provided with tropical finish to prevent fungus growth.

6.01.04 The actuator shall be designed for mounting in any position without any lubricant leakage or operating difficulty.

6.02.00 Motor





- 6.02.01 The drive motor shall be three phase, 415V, 50Hz squirrel cage, induction machine with minimum Class F insulated with three thermoswitches embedded, one in each winding of the motor for protection against burnout and IPW-67 enclosure, designed for high torque and reversing service.
- 6.02.02 The motor shall be designed for full voltage direct on-line start, with starting current limited to 6 times full-load current.
- 6.02.03 The motor shall be capable of starting at 85 percent of rated voltage and running at 80 percent of rated voltage at rated torque and 85 percent rated voltage at 33 percent excess rated torque for a period of 5 minutes each.
- 6.02.04 Earthing terminals shall be provided on either side of the motor.
- 6.03.00 **Limit Switches**
- Each actuator shall be provided with following limit switches: -
- 6.03.01 2 torque limit switches, one for each direction of travel, self-locking, adjustable torque type.
- 6.03.02 4 end-of-travel limit switches, two for each direction of travel.
- 6.03.03 2 position limit switches, one for each direction of travel, each adjustable at any position from fully open to fully closed positions of the valve/damper.
- 6.03.04 Each limit switch shall have 2 NO + 2 NC potential free contacts. Contact rating shall be 5A at 240V A.C. or 0.5A at 220V D.C.
- 6.03.05 Limit switches shall be drum type and adjustable to open, close and intermediate position.
- 6.03.06 The motor actuators shall have 2 nos. potentiometric type transmitters.
- 6.04.00 **Hand Wheel**
- Each actuator shall be provided with a hand wheel for emergency manual operation. The hand wheel shall declutch automatically when the motor is energized.
- 6.05.00 **Position Indicator/Transmitter**
- The actuator shall have:
- 6.05.01 One (1) built-in local position indicator for 0-100% travel
- 6.05.02 One (1) position transmitter, potentiometer type, for remote indicator
- 6.06.00 **Space Heater**





A space heater shall be included in the limit switch compartment suitable for 240V, 1 phase, 50 Hz supply.

6.07.00 **Wiring**

All electrical devices shall be wired up to and terminated in a terminal box. The internal wiring shall be of sufficient size for the power rating involved but in no case less than 1.5 Sq.mm copper. All wiring shall be identified at both ends with ferrules.

6.08.00 **Terminal Box**

The terminal box shall be weather proof, with removable front cover and cable glands for cable connection. The terminal shall be suitable for connection of 2x2.5 Sq.mm copper conductor.

6.09.00 **Interfaces:**

- i) Open/Close command termination logic with position & torque Limit Switches, positioner circuit shall be suitably built in the PCB inside the actuator.
- ii) For Binary Drive (both ON-OFF and Inching type) :- Open/Close command & status thereof and disturbance monitoring signal (common contact for Overload, Thermostat, control supply failure, L/R selector switch at local & other protections operated) shall be provided.
- iii) Interface with the control system shall be through hardwired signal only. Inter posing relays provided in the actuator shall be energized to initiate opening and closing, by 24V DC signal from the external control system.
- iv) For Modulating drive: - the command to actuator shall be in form of 4-20mA signal. The necessary positioning circuit and motor protection shall be provided.
- v) Open/close command termination logic shall be suitably built inside actuator.

7.00.00 **ACCESSORIES**

As required for the driven equipment, the actuator shall be furnished with starting equipment mounted on the actuator. This shall include:

7.01.00 One (1) triple pole breaker

7.02.00 One (1) reversing starter, with mechanically interlocked contactors, 3 thermal overload relays, 2 N.O. + 2 N.C. auxiliary contacts for each contactor.

7.03.00 One (1) remote-local selector switch

7.04.00 CLOSE-STOP-OPEN oil tight push buttons with indication lights





7.05.00 415/110V control transformer with primary & secondary fuses.

8.00.00 TEST

8.01.00 The actuator and all components thereof shall be subject to tests as per relevant standards. In addition, if any special test is called for in equipment specification, the same shall be performed.

8.02.00 Following routine test for integral starters shall be conducted as per IEC/IC standard. (a) Meggar Test, (b) Continuity test, (c) Operational test. Test certificates duly signed by inspecting agency shall be furnished.

8.03.00 The actuator shall be type tested as per IEC/National Standard, by international/national recognized test house. The test certificates issued by this house shall be furnished. Otherwise, the equipment shall have to be type tested, free of charge, to prove the design.

9.00.00 DRAWINGS, DATA & MANUALS

9.01.00 To be Submitted with Bid

Data sheet for each type of actuator shall be furnished along with internal wiring diagram, suggested control schematic and torque limit switch contact development and manufacturer's catalogues.

9.02.00 To be Submitted after Award of Contract

- a) Actuator Data Sheet
- b) Internal wiring diagram and suggested control schematic
- c) Torque switch and limit switch contact development
- d) Manufacturer's Catalogue
- e) Instruction manual indicating clearly the installation methods, check ups and tests to be carried out before commissioning of the equipment.





9.03.00 The Bidder may note that the drawings, data and manuals listed herein are minimum requirements only. The Bidder shall ensure that all other necessary write-ups, curves and information required to fully describe the equipment are submitted with his bid.



TYPICAL DRIVE INTERFACE

FOR TENDER PURPOSE ONLY



FILE LOCATION:
PLOT DATE:

								OWNER: NLC TAMILNADU POWER LIMITED			DEVELOPMENT CONSULTANTS PVT LTD. CONSULTING ENGINEERS KOLKATA • MUMBAI • CHENNAI • NEW DELHI
								PROJECT: 2x500 MW THERMAL POWER PLANT AT TUTICORIN	PREPARED AAM	JOB NO. 17A14	
	0	09.08.2018	AAM	AKP	AT	FIRST ISSUE			CHECKED AKP	SCALE NIL	
REV	DATE	PREPD	CHKD	APPVD	NATURE OF REVISION & DESCRIPTION		TITLE: TYPICAL DRIVE INTERFACE	APPROVED AT	DATE 09.08.2018	REV 0	1 SHEET OF 8
REVISION STATUS								DWG. NO. 17A14-DWG-I-0021			

S/N	DESCRIPTION	SHEET NO.
1.	COVER SHEET	1 OF 8
2.	INDEX SHEET	2 OF 8
3.	PLC INTERFACE FOR BIDIRECTIONAL DRIVE (WITH INTEGRAL STARTER)	3 OF 8
4.	PLC INTERFACE FOR UNIDIRECTIONAL LT DRIVE (CONTACTOR OPERATED)	4 OF 8
5.	PLC INTERFACE FOR UNIDIRECTIONAL HT/LT DRIVE (BREAKER OPERATED)	5 OF 8
6.	PLC INTERFACE FOR BIDIRECTIONAL DRIVE (WITH NON INTEGRAL STARTER)	6 OF 8
7.	PLC INTERFACE FOR ON/OFF SOLENOID ACTUATED DRIVE	7 OF 8
8.	PLC INTERFACE FOR CONTROL VALVE	8 OF 8

FOR TENDER PURPOSE ONLY

FILE LOCATION:
PLOT DATE:

					 OWNER: NLC TAMILNADU POWER LIMITED		 DEVELOPMENT CONSULTANTS PVT LTD. CONSULTING ENGINEERS KOLKATA • MUMBAI • CHENNAI • NEW DELHI			
					PROJECT: 2x500 MW THERMAL POWER PLANT AT TUTICORIN		PREPARED AAM	JOB NO. 17A14		
FIRST ISSUE							CHECKED AKP	SCALE NIL		
REV	DATE	PREPD	CHKD	APPVD	NATURE OF REVISION & DESCRIPTION	TITLE: TYPICAL DRIVE INTERFACE		APPROVED AT	DATE 09.08.2018	REV 0
REVISION STATUS								DWG. NO. 17A14-DWG-I-0021	2 OF 8 SHEETS	

FILE LOCATION: C:\Users\Administrator\Desktop\AYAN\21-08-2018\17A14-DWG-I-0021-R-0-SHT-3-8.dwg
PLOT DATE: 21 August 2018, 12:08 PM

PLC INTERFACE FOR BIDIRECTIONAL DRIVE (WITH INTEGRAL STARTER)

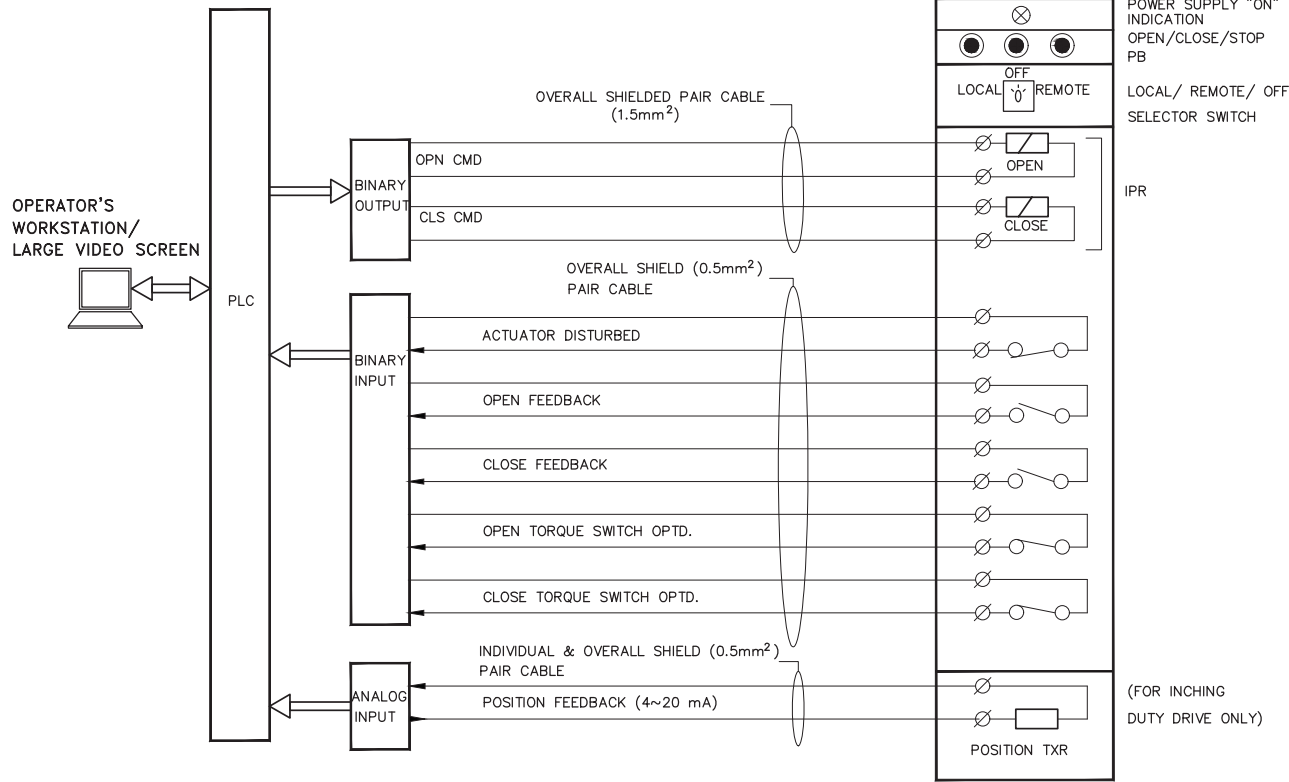

NOTE:

1. ACTUATOR DISTURBED CONSIST OF FOLLOWING SIGNALS: -
 - a) LOSS OF POWER SUPPLY,
 - b) LOSS OF CONTROL SUPPLY, MOTOR THERMOSTAT TRIP,
 - c) THERMAL OVER LOAD RELAY TRIP,
 - d) TORQUE OPEN/CLOSE CUT OFF,
 - e) LOCAL/OFF/REMOTE SEL. SWITCH IN LOCAL OR OFF MODE.
 - f) VALVE JAMMED.
 - g) EMERGENCY STOP PB PRESSED.
2. PLC VENDOR SHALL FURNISH DETAILED INTERFACE SCHEMES BASED ON THIS BASIC DIAGRAM AND SPECIFICATION.
3. IPR - INTERPOSING RELAY (TO BE LOCATED INSIDE THE INTEGRAL STARTER)
4. RELEVANT PARTS OF THE SPECIFICATION SHALL BE REFERRED FOR OTHER SPECIFIC REQUIREMENTS (FOR EXAMPLE REDUNDANCY)

FOR TENDER PURPOSE ONLY

0	09.08.2018	AAM	AKP	AT	FIRST ISSUE
REV	DATE	PREPD	CHKD	APPVD	NATURE OF REVISION & DESCRIPTION
REVISION STATUS					

	OWNER: NLC TAMILNADU POWER LIMITED
PROJECT:	2x500 MW THERMAL POWER PLANT AT TUTICORIN
TITLE:	TYPICAL DRIVE INTERFACE

	DEVELOPMENT CONSULTANTS PVT LTD. CONSULTING ENGINEERS KOLKATA • MUMBAI • CHENNAI • NEW DELHI			
PREPARED	AAM	JOB NO.	17A14	
CHECKED	AKP	SCALE	NIL	
APPROVED	AT	DATE	09.08.2018	
DWG. NO.	17A14-DWG-I-0021			REV 0
				3 SHEETS OF 8

PLC INTERFACE FOR UNIDIRECTIONAL LT DRIVE (CONTACTOR OPERATED)

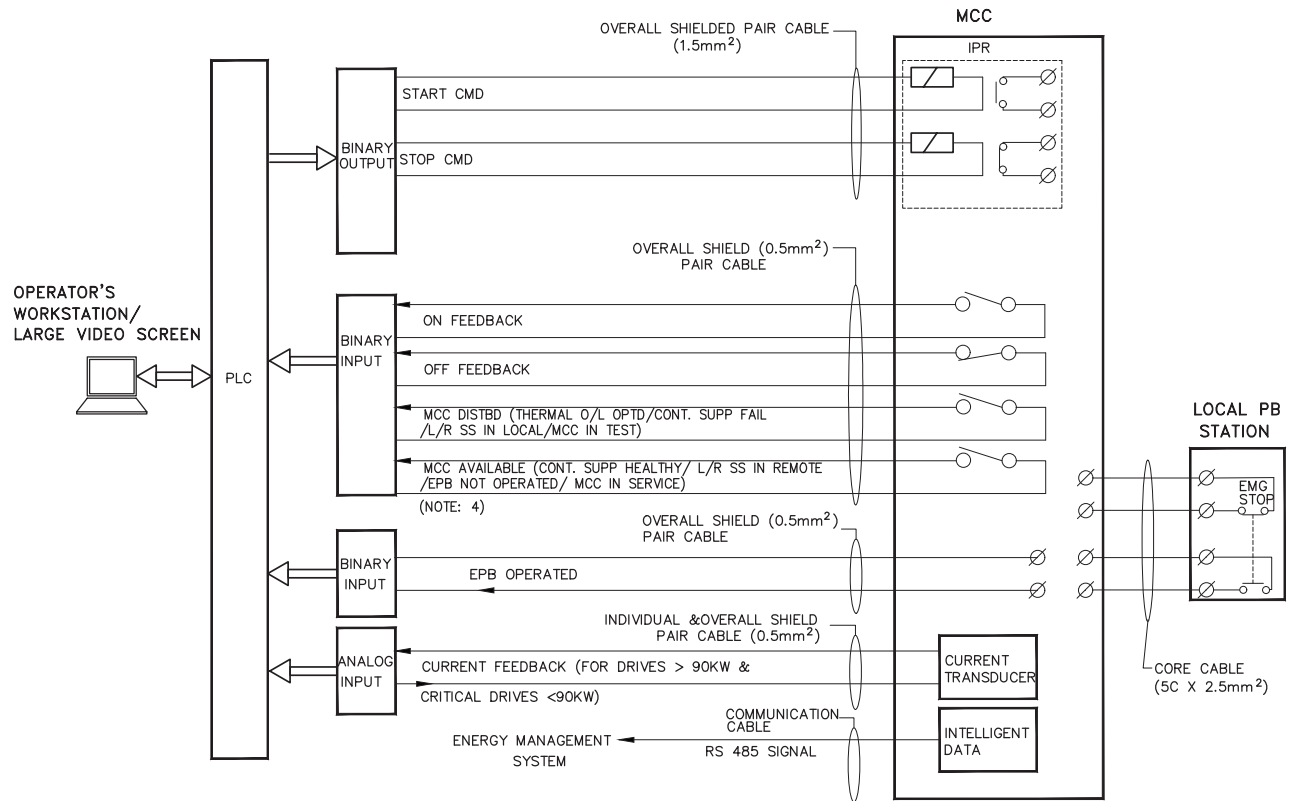

NOTE:

1. IPR – INTERPOSING RELAY
2. PLC VENDOR SHALL FURNISH DETAILED INTERFACE SCHEMES BASED ON THIS BASIC DIAGRAM AND SPECIFICATION.
3. RELEVANT PARTS OF THE SPECIFICATION SHALL BE REFERRED FOR OTHER SPECIFIC REQUIREMENTS (FOR EXAMPLE REDUNDANCY).

FOR TENDER PURPOSE ONLY

FILE LOCATION: C:\Users\Administrator\Desktop\AYAN\21-08-2018\17A14-DWG-I-0021-R-0-SHT-4-8.dwg
PLOT DATE: 21 August 2018, 12:07 PM

					OWNER: NLC TAMILNADU POWER LIMITED		DEVELOPMENT CONSULTANTS PVT LTD. CONSULTING ENGINEERS KOLKATA • MUMBAI • CHENNAI • NEW DELHI				
0	09.08.2018	AAM	AKP	AT	PROJECT: 2x500 MW THERMAL POWER PLANT AT TUTICORIN		PREPARED	AAM	JOB NO.	17A14	
FIRST ISSUE					TITLE: TYPICAL DRIVE INTERFACE		CHECKED	AKP	SCALE	NIL	
REV	DATE	PREPD	CHKD	APPVD	NATURE OF REVISION & DESCRIPTION		APPROVED	AT	DATE	09.08.2018	REV 0
REVISION STATUS							DWG. NO.	17A14-DWG-I-0021			4 SHEETS OF 8

FILE LOCATION: C:\Users\Administrator\Desktop\AYAN\21-08-2018\17A14-DWG-I-0021-R-0-SHT-5-8.dwg
PLOT DATE: 21 August 2018, 12:09 PM

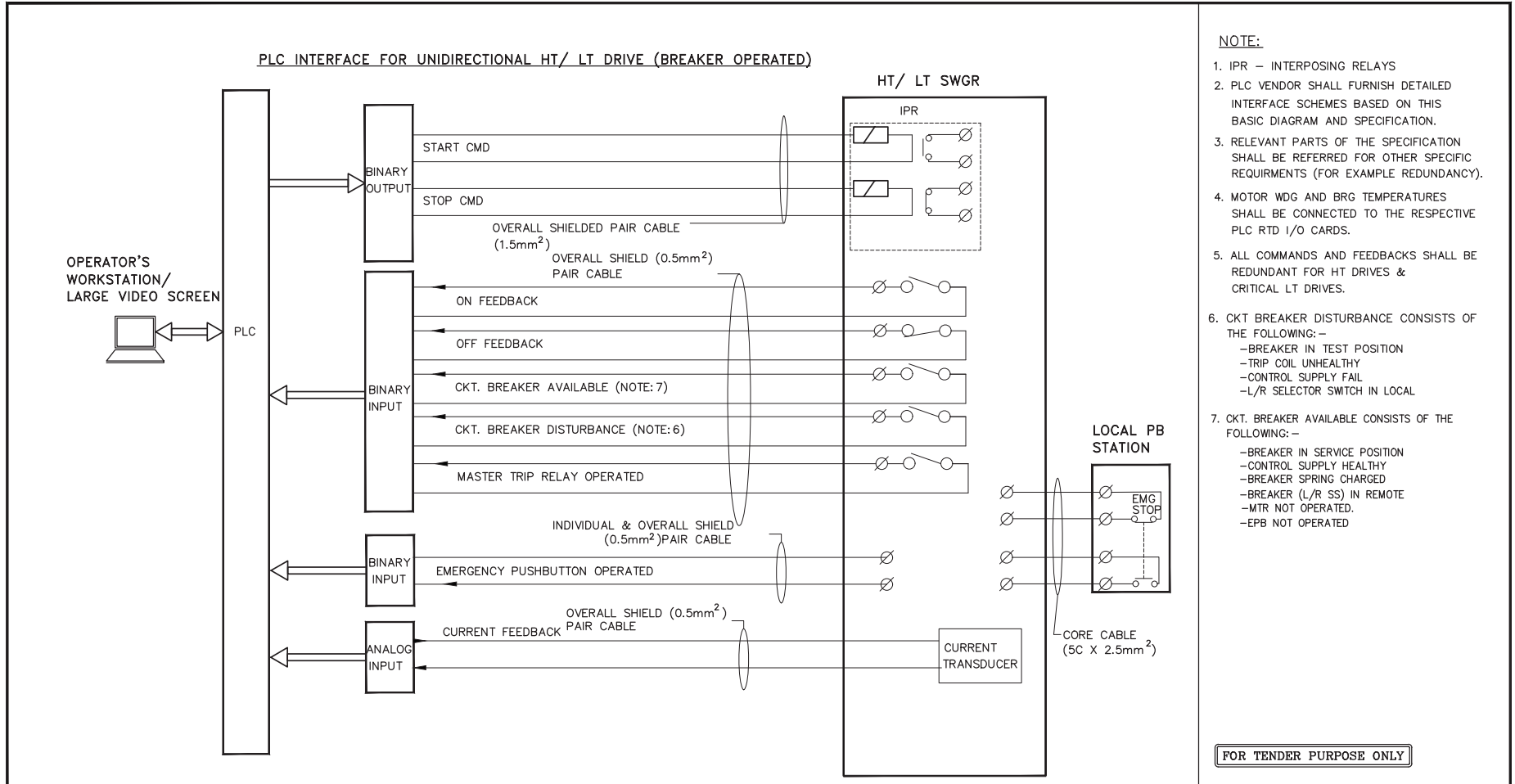

					OWNER: NLC TAMILNADU POWER LIMITED		DEVELOPMENT CONSULTANTS PVT LTD. CONSULTING ENGINEERS KOLKATA • MUMBAI • CHENNAI • NEW DELHI												
					PROJECT: 2x500 MW THERMAL POWER PLANT AT TUTICORIN		PREPARED AAM	JOB NO. 17A14											
					TITLE: TYPICAL DRIVE INTERFACE		CHECKED AKP	SCALE NIL											
<table border="1"> <thead> <tr> <th>REV</th> <th>DATE</th> <th>PREPD</th> <th>CHKD</th> <th>APPVD</th> <th>NATURE OF REVISION & DESCRIPTION</th> </tr> </thead> <tbody> <tr> <td>0</td> <td>09.08.2018</td> <td>AAM</td> <td>AKP</td> <td>AT</td> <td>FIRST ISSUE</td> </tr> </tbody> </table>					REV	DATE	PREPD	CHKD	APPVD	NATURE OF REVISION & DESCRIPTION	0	09.08.2018	AAM	AKP	AT	FIRST ISSUE	APPROVED AT	DATE 09.08.2018	REV 0
REV	DATE	PREPD	CHKD	APPVD	NATURE OF REVISION & DESCRIPTION														
0	09.08.2018	AAM	AKP	AT	FIRST ISSUE														
<table border="1"> <thead> <tr> <th colspan="5">REVISION STATUS</th> </tr> </thead> <tbody> <tr> <td> </td> <td> </td> <td> </td> <td> </td> <td> </td> </tr> </tbody> </table>					REVISION STATUS										DWG. NO. 17A14-DWG-I-0021	5 SHEETS OF 8			
REVISION STATUS																			

FILE LOCATION: C:\Users\Administrator\Desktop\AYAN\21-08-2018\17A14-DWG-I-0021-R-0-SHT-6-8.dwg
PLOT DATE: 21 August 2018, 12:10 PM

PLC INTERFACE FOR BIDIRECTIONAL DRIVE (WITH NON INTEGRAL STARTER)

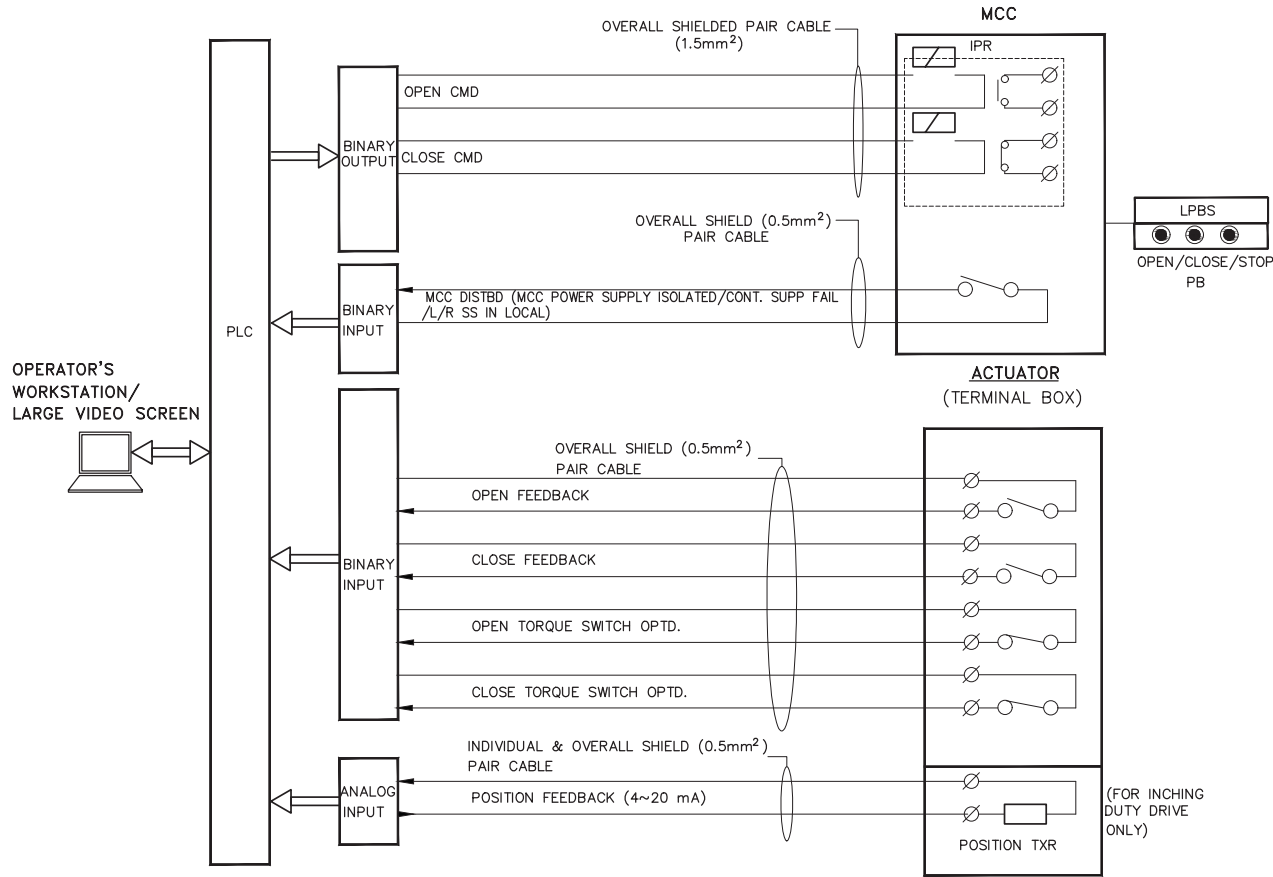

NOTE:

1. IPR - INTERPOSING RELAY
2. PLC VENDOR SHALL FURNISH DETAILED INTERFACE SCHEMES BASED ON THIS BASIC DIAGRAM AND SPECIFICATION.
3. RELEVANT PARTS OF THE SPECIFICATION SHALL BE REFERRED FOR OTHER SPECIFIC REQUIREMENTS (FOR EXAMPLE REDUNDANCY).

FOR TENDER PURPOSE ONLY

REV	DATE	PREPD	CHKD	APPVD	NATURE OF REVISION & DESCRIPTION
0	09.08.2018	AAM	AKP	AT	FIRST ISSUE
REVISION STATUS					

	OWNER: NLC TAMILNADU POWER LIMITED
PROJECT:	2x500 MW THERMAL POWER PLANT AT TUTICORIN
TITLE:	TYPICAL DRIVE INTERFACE

	DEVELOPMENT CONSULTANTS PVT LTD. CONSULTING ENGINEERS KOLKATA • MUMBAI • CHENNAI • NEW DELHI			
PREPARED	AAM	JOB NO.	17A14	
CHECKED	AKP	SCALE	NIL	
APPROVED	AT	DATE	09.08.2018	
DWG. NO.	17A14-DWG-I-0021			REV 0 6 SHEETS OF 8

FILE LOCATION: C:\Users\Administrator\Desktop\AYAN\21-08-2018\17A14-DWG-I-0021-R-0-SHT-7-8.dwg
PLOT DATE: 21 August 2018, 12:11 PM

PLC INTERFACE FOR ON/OFF SOLENOID ACTUATED DRIVE

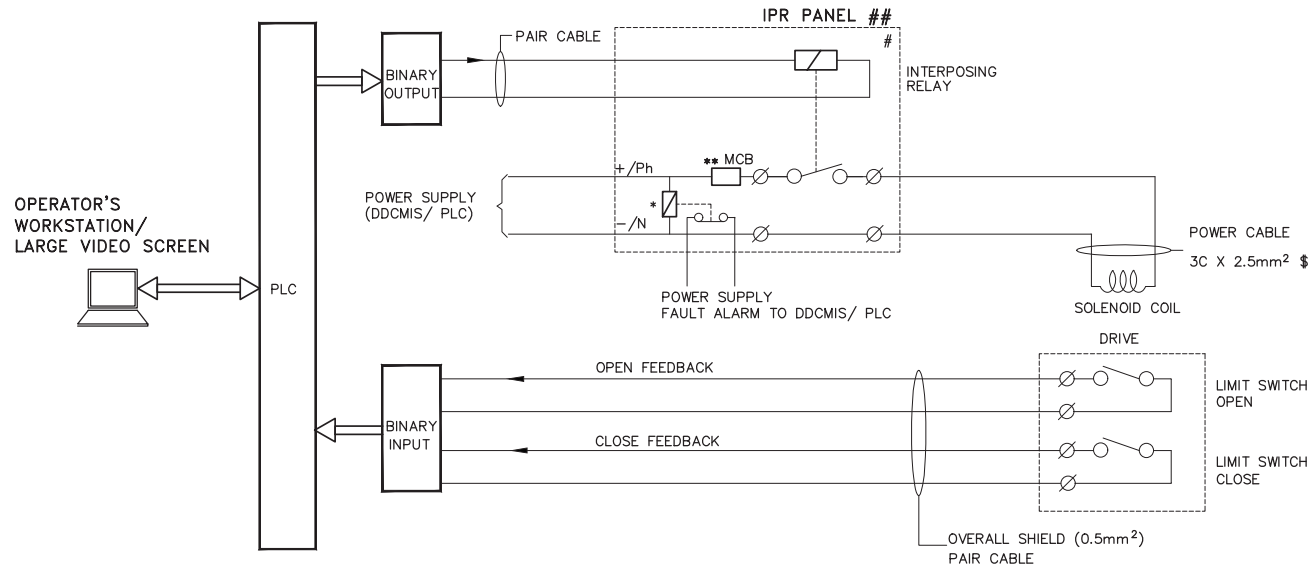

NOTE:





1. ** MCB SHALL BE PROVIDED FOR EACH SOLENOID.
2. * COMMON FOR ALL SOLENOIDS OF SIMILAR COIL VOLTAGE RATING.
3. PLC VENDOR SHALL FURNISH DETAILED INTERFACE SCHEMES BASED ON THIS BASIC DIAGRAM AND SPECIFICATION.
4. TWO INDEPENDENT OUTPUTS FROM PLC SHALL BE PROVIDED TO PUSH - PULL TYPE VALVES WITH DUAL COIL SOLENOIDS. RELEVANT PARTS OF THE SPECIFICATION SHALL BE REFERRED FOR OTHER SPECIFIC REQUIREMENTS.
5. \$ POWER CABLE CROSS SECTION SHALL BE AS PER CABLE SIZING CALCULATION.
6. # FOR DOUBLE SOLENOID VALVES, SAME ARRANGEMENT SHALL BE APPLICABLE FOR SECOND SOLENOID.
7. ## IPR PANEL SHALL BE INTEGRAL FOR THE PLC BASED SYSTEMS.

FOR TENDER PURPOSE ONLY

					OWNER: NLC TAMILNADU POWER LIMITED		DEVELOPMENT CONSULTANTS PVT LTD. CONSULTING ENGINEERS KOLKATA • MUMBAI • CHENNAI • NEW DELHI		
					PROJECT: 2x500 MW THERMAL POWER PLANT AT TUTICORIN		PREPARED AAM	JOB NO. 17A14	
					TITLE: TYPICAL DRIVE INTERFACE		CHECKED AKP	SCALE NIL	
0 09.08.2018 AAM AKP AT FIRST ISSUE							APPROVED AT	DATE 09.08.2018	REV 0
REVISION STATUS NATURE OF REVISION & DESCRIPTION							DWG. NO. 17A14-DWG-I-0021	7 SHEETS OF 8	

TYPICAL INSTRUMENT INSTALLATION DIAGRAM

FOR TENDER PURPOSE ONLY





								OWNER: NLC TAMILNADU POWER LIMITED			DEVELOPMENT CONSULTANTS PVT LTD. CONSULTING ENGINEERS KOLKATA • MUMBAI • CHENNAI • NEW DELHI
								PROJECT: 2x500 MW THERMAL POWER PLANT AT TUTICORIN	<i>PREPARED</i> AAM	<i>JOB NO.</i> 17A14	
									<i>CHECKED</i> AKP	<i>SCALE</i> NIL	
<i>REV</i>	<i>DATE</i>	<i>PREPD</i>	<i>CHKD</i>	<i>APPVD</i>				TITLE: TYPICAL INSTRUMENT INSTALLATION DIAGRAM	<i>APPROVED</i> AT	<i>DATE</i> 10.08.2018	REV 0
REVISION STATUS					NATURE OF REVISION & DESCRIPTION				DWG. NO. 17A14-DWG-I-0022		1 SHEET OF 16
0	10.08.2018	AAM	AKP	AT	FIRST ISSUE						

FILE LOCATION:
PLOT DATE:

NOTES :

- 1..PROVISION OF SINGLE OR DOUBLE ROOT VALVE AND DRAIN VALVE SHALL BE IN ACCORDANCE WITH THE PRESSURE/TEMPERATURE REQUIREMENT. FOR LINE PRESSURE EQUAL TO OR GREATER THAN 40 KG/SQ.CM 2 NOS ROOT VALVE AND 2 NOS DRAIN VALVE SHALL BE REQUIRED.
- 2..MATERIAL, SIZE AND RATING OF THE PROCESS HOOK UP ITEMS SHOWN IN THE DRAWING ARE INDICATIVE ONLY. ACTUAL REQUIREMENT SHALL BE AS PER PROCESS CONDITION & SPECIFICATION V.IIE/S-III
- 3..DRAIN PIPE IN RACK AND ENCLOSURE SHALL BE 2" NB ASTM A 106 SCH 80 Gr.C. DRAIN HEADER SHALL BE TO THE NEAREST DRAIN PIT AS PER SITE CONDITION.
- 4..ALL FITTINGS SHALL BE WITH DOUBLE COMPRESSION FERRULE & NUTS.
- 5..UNION SHALL BE USED AT EVERY 6M INTERVAL OF IMPULSE LINE OR AS REQUIRED.
- 6..IMPULSE LINE SHALL BE SUPPORTED WITH U-CLAMPING AT EVERY 2.5M SPAN.

FOR TENDER PURPOSE ONLY

							 NTPL	OWNER: NLC TAMILNADU POWER LIMITED			DEVELOPMENT CONSULTANTS PVT LTD. CONSULTING ENGINEERS KOLKATA • MUMBAI • CHENNAI • NEW DELHI
								PROJECT: 2x500 MW THERMAL POWER PLANT AT TUTICORIN	PREPARED AAM	JOB NO. 17A14	
0	10.08.2018	AAM	AKP	AT		FIRST ISSUE			CHECKED AKP	SCALE NIL	
REV	DATE	PREPD	CHKD	APPVD		NATURE OF REVISION & DESCRIPTION		TITLE: TYPICAL INSTRUMENT INSTALLATION DIAGRAM	APPROVED AT	DATE 10.08.2018	REV 0
REVISION STATUS									DWG. NO. 17A14-DWG-I-0022		3 SHEETS OF 16

**PRESSURE TRANSMITTER/PRESSURE SWITCH
MOUNTED BELOW SOURCE POINT**

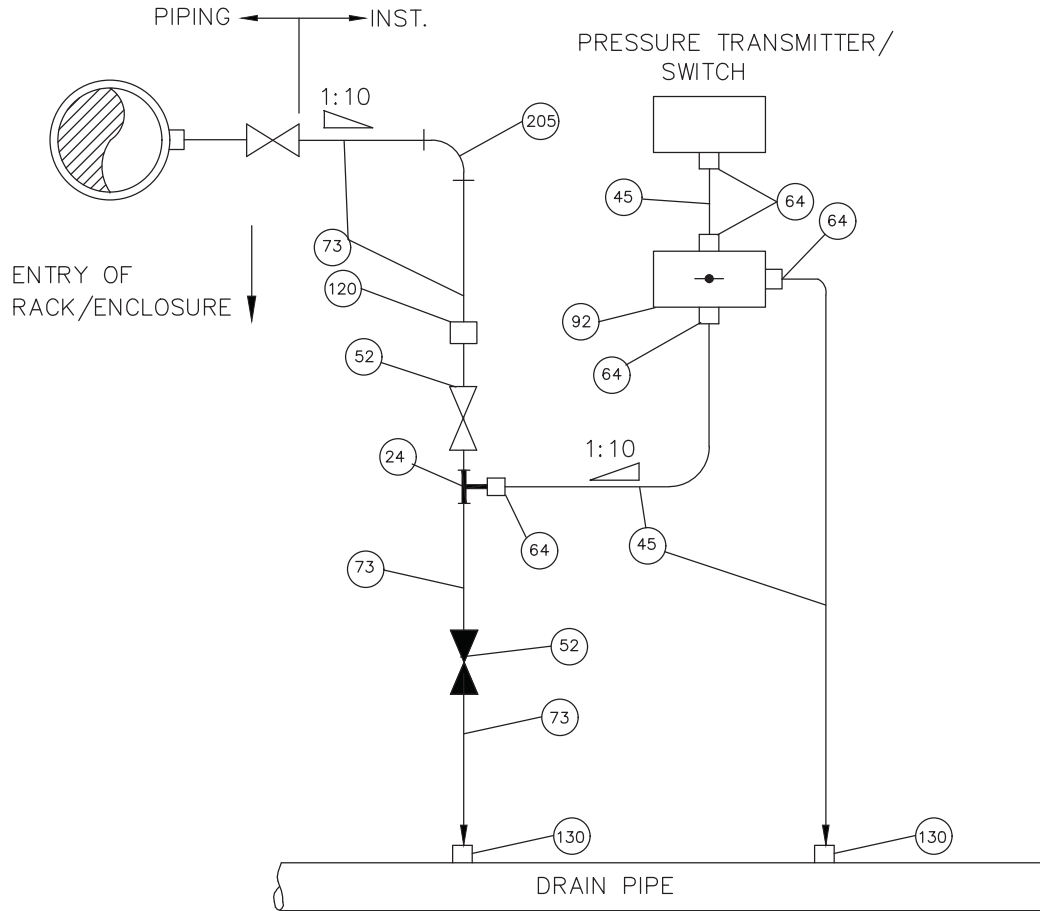

BILL OF MATERIAL		
ITEM NO.	QTY./INST	DESCRIPTION
24	1	UNEQUAL TEE, 1/2" SW X 1/2" NPT (F)
45	3 M	TUBE, 1/2" OD
52	2	GLOBE VALVES, 1/2" SW
64	8	MALE CONNECTOR, 1/2" NPT (M) X 1/2" OD
73	15 M	IMPULSE PIPE, 15 NB
92	1	2 VALVE MANIFOLD, 1/2" NPT (F)
120	1	BULK-HEAD UNION, 1/2" SW
130	2	HALF COUPLING, 1/2" SW
205	1	90° ELBOW, 1/2" SW

SERVICE : WATER.

FOR TENDER PURPOSE ONLY

FILE LOCATION: C:\Users\Administrator\Desktop\AYAN\INST\17A14-DWG-I-0022-R-0-SHT-5-20 (PT).dwg
PLOT DATE: 16 August 2018, 12:15 PM

					OWNER: NLC TAMILNADU POWER LIMITED		DEVELOPMENT CONSULTANTS PVT LTD. CONSULTING ENGINEERS KOLKATA • MUMBAI • CHENNAI • NEW DELHI																		
					PROJECT: 2x500 MW THERMAL POWER PLANT AT TUTICORIN		PREPARED AAM	JOB NO. 17A14																	
					TITLE: TYPICAL INSTRUMENT INSTALLATION DIAGRAM		CHECKED AKP	SCALE NIL																	
<table border="1"> <thead> <tr> <th>REV</th> <th>DATE</th> <th>PREPD</th> <th>CHKD</th> <th>APPVD</th> <th>NATURE OF REVISION & DESCRIPTION</th> </tr> </thead> <tbody> <tr> <td>0</td> <td>10.08.2018</td> <td>AAM</td> <td>AKP</td> <td>AT</td> <td>FIRST ISSUE</td> </tr> <tr> <td colspan="5">REVISION STATUS</td> <td></td> </tr> </tbody> </table>					REV	DATE	PREPD	CHKD		APPVD	NATURE OF REVISION & DESCRIPTION	0	10.08.2018	AAM	AKP	AT	FIRST ISSUE	REVISION STATUS						APPROVED AT	DATE 10.08.2018
REV	DATE	PREPD	CHKD	APPVD	NATURE OF REVISION & DESCRIPTION																				
0	10.08.2018	AAM	AKP	AT	FIRST ISSUE																				
REVISION STATUS																									
					DWG. NO. 17A14-DWG-I-0022		4 SHEETS OF 16																		

PRESSURE TRANSMITTER/PRESSURE SWITCH
MOUNTED ABOVE SOURCE POINT

BILL OF MATERIAL		
ITEM NO.	QTY./INST	DESCRIPTION
24	1	UNEQUAL TEE, 1/2" SW X 1/2" NPT (F)
45	3 M	TUBE, 1/2" OD
52	1	GLOBE VALVE, 1/2" SW
64	4	MALE CONNECTOR 1/2" NPT(M) X 1/2" OD
73	15 M	IMPULSE PIPE, 15 NB
73a	1	NIPPLE, 1/2" SW X 1/2" NPT (F), 150 MM
92	1	2-VALVE MANIFOLD, 1/2" NPT (F)
92a	2	VENT PLUG, 1/2" NPT (M)
120	1	BULK HEAD UNION/COUPLING, 1/2" SW
205	1	90° ELBOW, 1/2" SW

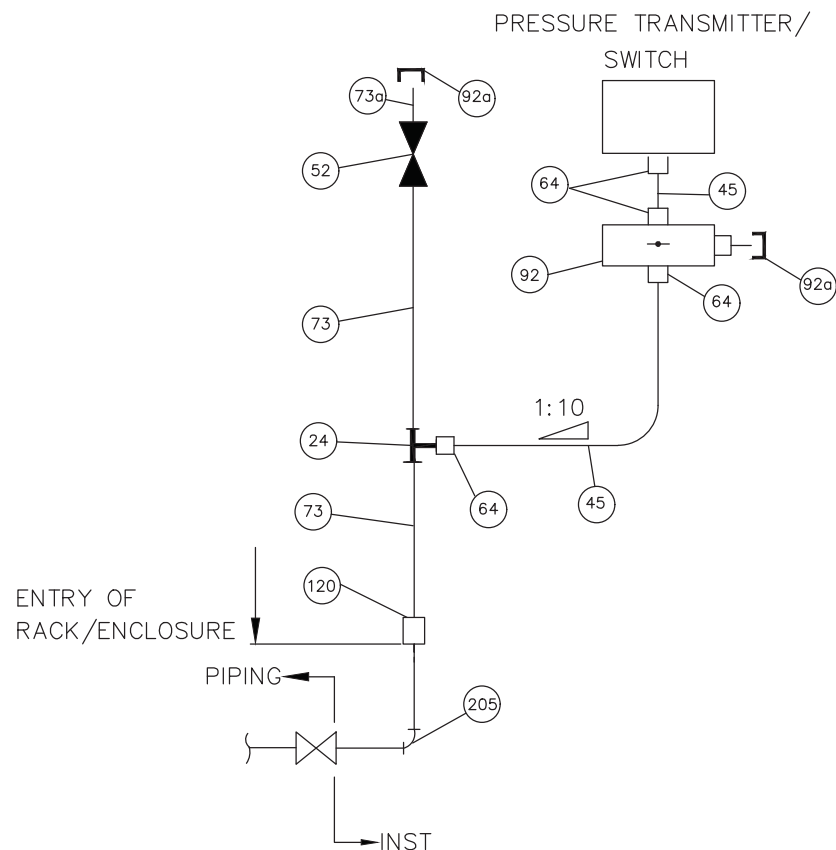

SERVICE : AIR

FOR TENDER PURPOSE ONLY

FILE LOCATION: C:\Users\Administrator\Desktop\AYAN\INST\17A14-DWG-I-0022-R-0-SHT-7-20 (PT).dwg
PLOT DATE: 16 August 2018, 12:16 PM

						OWNER: NLC TAMILNADU POWER LIMITED		DEVELOPMENT CONSULTANTS PVT LTD. CONSULTING ENGINEERS KOLKATA • MUMBAI • CHENNAI • NEW DELHI			
					PROJECT: 2x500 MW THERMAL POWER PLANT AT TUTICORIN		PREPARED	AAM	JOB NO.	17A14	
					TITLE: TYPICAL INSTRUMENT INSTALLATION DIAGRAM		CHECKED	AKP	SCALE	NIL	REV 0
REV	DATE	PREPD	CHKD	APPVD	NATURE OF REVISION & DESCRIPTION		APPROVED	AT	DATE	10.08.2018	
REVISION STATUS							DWG. NO.	17A14-DWG-I-0022		5 SHEETS OF 16	
0	10.08.2018	AAM	AKP	AT	FIRST ISSUE						

PRESSURE GAUGE

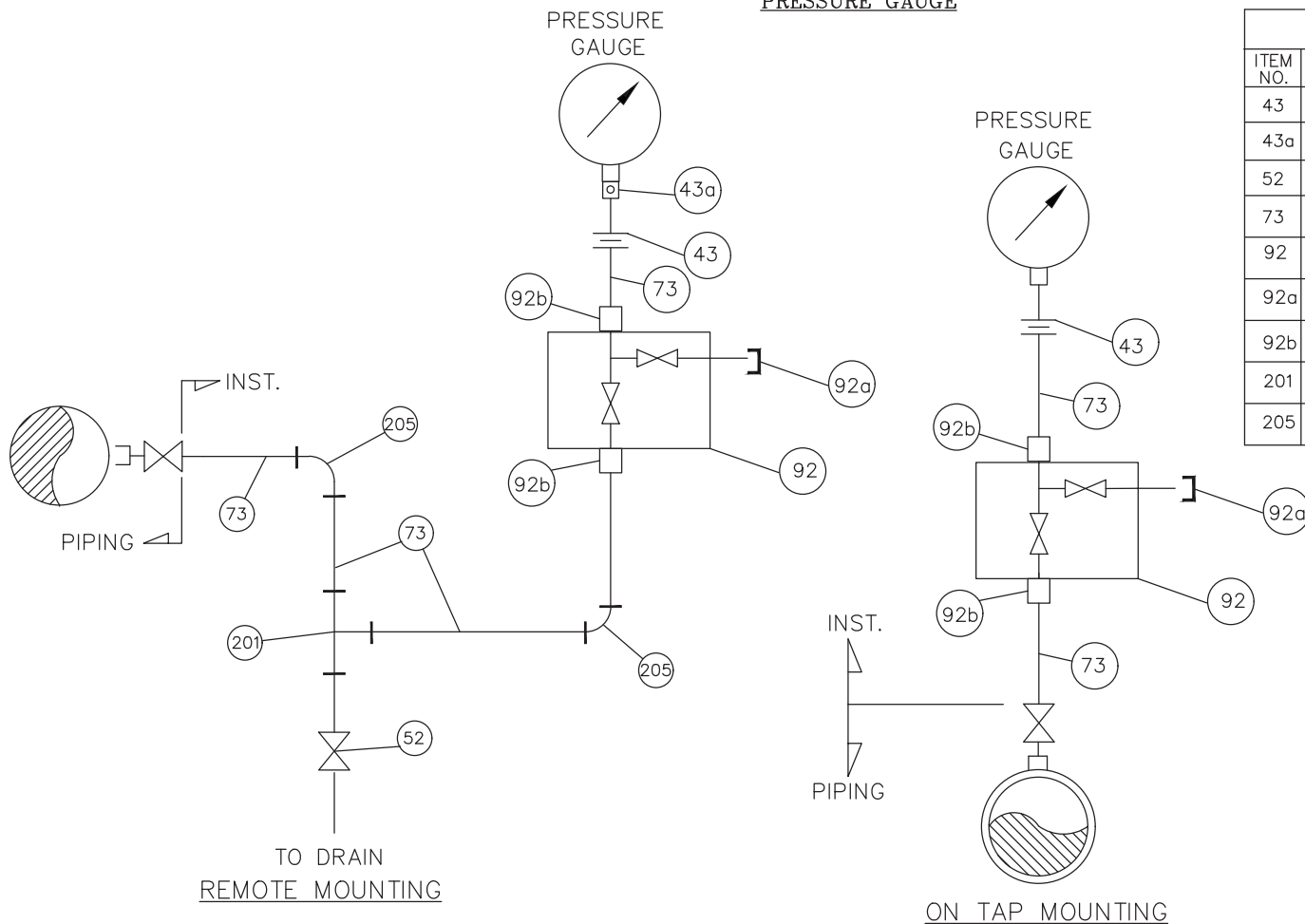

BILL OF MATERIAL		
ITEM NO.	QTY./INST.	DESCRIPTION
43	1	THREE PIECE UNION, 1/2" SW X 1/2" NPT (F)
43a	1	SNUBBER, 1/2" NPT (M) X 1/2" NPT (F) (AT PUMP DISCHARGE)
52	1	GLOBE VALVE, 1/2" SW
73	15Mtrs	IMPULSE PIPE 15 NB
92	1	2 VALVE MANIFOLD, 1/2" NPT (F)
92a	1	VENT PLUG, 1/2" NPT (M)
92b	1	ADAPTOR, 1/2" SW X 1/2" NPT (M)
201	1	EQUAL TEE 1/2" SW
205	2	90° ELBOW 1/2" SW

SERVICE : WATER

FOR TENDER PURPOSE ONLY

FILE LOCATION: C:\Users\Administrator\Desktop\AYAN\INST\17A14-DWG-I-0022-R-0-SHT-13-20 (PG).dwg
PLOT DATE: 16 August 2018, 12:21 PM

REV	DATE	PREPD	CHKD	APPVD	NATURE OF REVISION & DESCRIPTION
0	10.08.2018	AAM	AKP	AT	FIRST ISSUE
REVISION STATUS					

	OWNER: NLC TAMILNADU POWER LIMITED
PROJECT:	2x500 MW THERMAL POWER PLANT AT TUTICORIN
TITLE:	TYPICAL INSTRUMENT INSTALLATION DIAGRAM

	DEVELOPMENT CONSULTANTS PVT LTD. CONSULTING ENGINEERS KOLKATA • MUMBAI • CHENNAI • NEW DELHI		
PREPARED	AAM	JOB NO.	17A14
CHECKED	AKP	SCALE	NIL
APPROVED	AT	DATE	10.08.2018
DWG. NO.	17A14-DWG-I-0022		REV 0
			10 SHEETS OF 16

**PRESSURE TRANSMITTER/PRESSURE SWITCH
WITH REMOTE DIAPHRAGM SEAL**

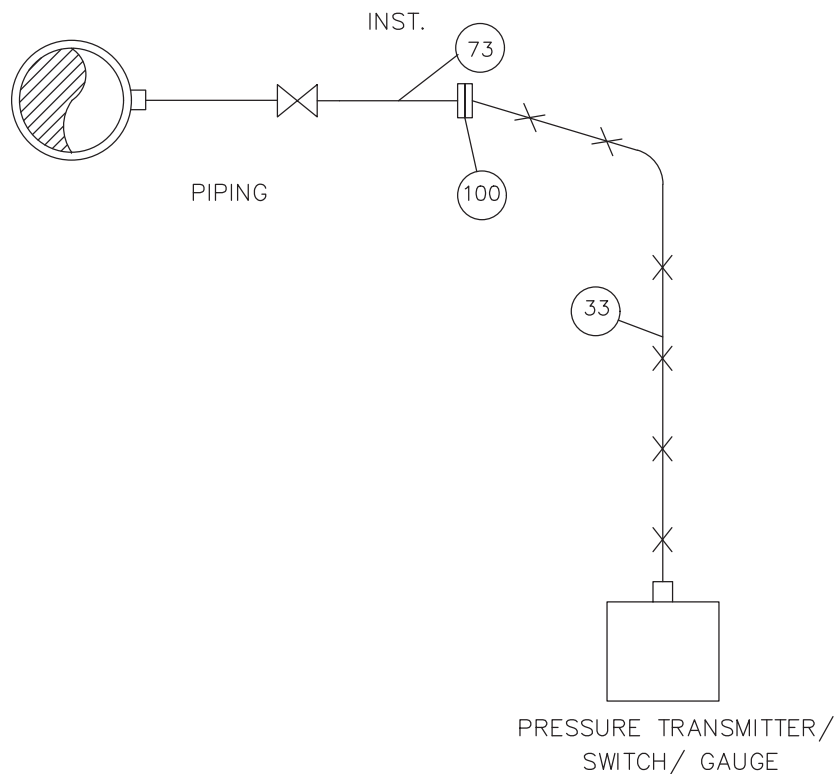

BILL OF MATERIAL		
ITEM NO.	QTY./ INST.	DESCRIPTION
33	A/R	SS ARMoured CAPILLARY TUBE
73	1 M	IMPULSE PIPE, 15 NB
100	1	FLANGE ASSEMBLY TO SUIT 1/2" PIPE

SERVICE: CORROSIVE/ VISCOUS/SOLID BEARING OR SLURRY SERVICE

FOR TENDER PURPOSE ONLY

FILE LOCATION: C:\Users\Administrator\Desktop\AYAN\INST INSL\17A14-DWG-I-0022-R-0-SHT-15-20 (DIA SEAL).dwg
PLOT DATE: 16 August 2018, 12:23 PM

						OWNER: NLC TAMILNADU POWER LIMITED		DEVELOPMENT CONSULTANTS PVT LTD. CONSULTING ENGINEERS KOLKATA • MUMBAI • CHENNAI • NEW DELHI		
						PROJECT: 2x500 MW THERMAL POWER PLANT AT TUTICORIN	PREPARED AAM	JOB NO. 17A14		
						TITLE: TYPICAL INSTRUMENT INSTALLATION DIAGRAM	CHECKED AKP	SCALE NIL		
						APPROVED AT	DATE 10.08.2018	REV 0		
REV	DATE	PREPD	CHKD	APPVD	NATURE OF REVISION & DESCRIPTION	DWG. NO. 17A14-DWG-I-0022				11 SHEET OF 16

**PRESSURE TRANSMITTER
MOUNTED ABOVE SOURCE POINT**

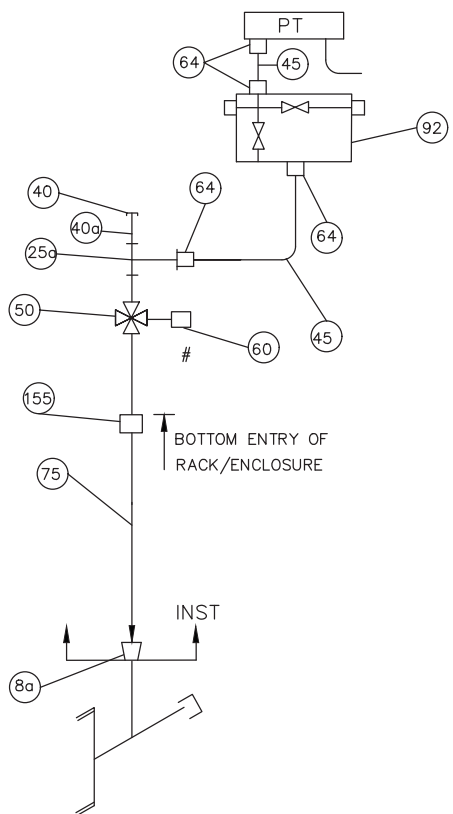

BILL OF MATERIAL		
ITEM NO.	QTY./INST	DESCRIPTION
8a	1	REDUCER 1" NB X 3/4" NB-SW
25	1	EQUAL TEE, 3/4" SW
25a	1	UNEQUAL TEE, 3/4" SW (2) X 1/2" NPT (F)
40	1	PLUG, 3/4" NPT (M)
40a	1	NIPPLE, 3/4" SW X 3/4" NPT (F), 150 MM
45	3 M	TUBE, 1/2" OD
50	1	FOUR WAY VALVE SIZE : (2 X 3/4" NB-SW) X (2 X 1/2" NPTF)
60	1	QUICK DISCONNECTING FITTING SIZE: 1/2" NPT(M)
64	4	MALE CONNECTOR, 1/2" NPT (M) X 1/2" OD
75	A/R	IMPULSE PIPE, 15 NB
93	1	3 VALVE MANIFOLD, 1/2" NPT(F)
155	1	BULK HEAD UNION, 3/4" SW

SERVICE : FLUE GAS.

FOR TENDER PURPOSE ONLY

FILE LOCATION: C:\Users\Administrator\Desktop\AYAN\INST INSL\17A14-DWG-I-0022-R-0-SHT-18-20 (PT-FLUE).dwg
PLOT DATE: 16 August 2018, 12:27 PM

REV	DATE	PREPD	CHKD	APPVD	NATURE OF REVISION & DESCRIPTION
0	10.08.2018	AAM	AKP	AT	FIRST ISSUE
REVISION STATUS					

	OWNER: NLC TAMILNADU POWER LIMITED
PROJECT: 2x500 MW THERMAL POWER PLANT AT TUTICORIN	
TITLE: TYPICAL INSTRUMENT INSTALLATION DIAGRAM	

	DEVELOPMENT CONSULTANTS PVT LTD. CONSULTING ENGINEERS KOLKATA • MUMBAI • CHENNAI • NEW DELHI		
PREPARED	AAM	JOB NO.	17A14
CHECKED	AKP	SCALE	NIL
APPROVED	AT	DATE	10.08.2018
DWG. NO.	17A14-DWG-I-0022		REV 0
			14 SHEETS OF 16

FILE LOCATION: C:\Users\Administrator\Desktop\AYAN\INST\17A14-DWG-I-0022-R-0-SHT-20-20 (SOV).dwg
 PLOT DATE: 16 August 2018, 12:29 PM

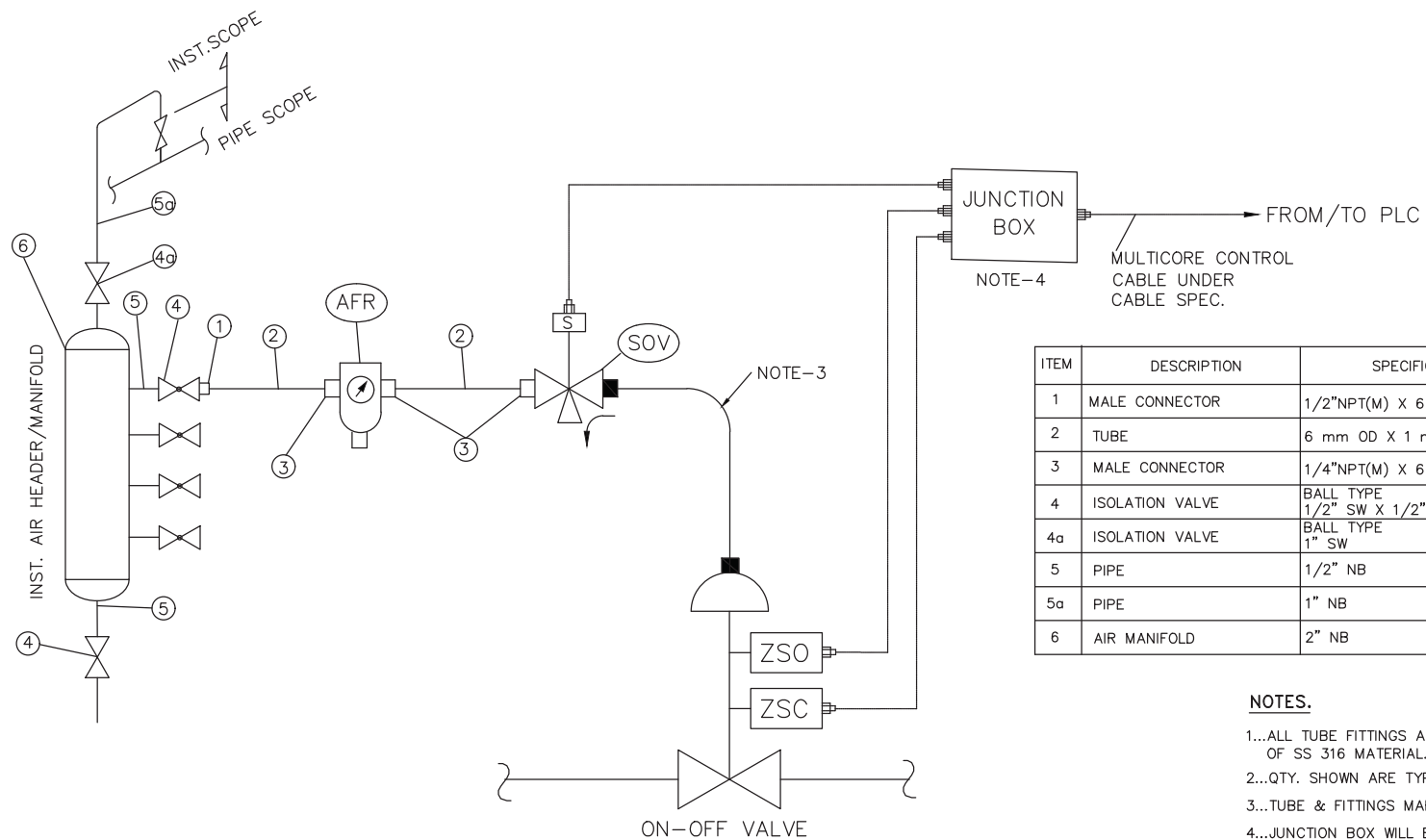

ITEM	DESCRIPTION	SPECIFICATION	QTY.	REMARKS
1	MALE CONNECTOR	1/2"NPT(M) X 6 mm OD	1	
2	TUBE	6 mm OD X 1 mm THK.	10 MTRS.	
3	MALE CONNECTOR	1/4"NPT(M) X 6 mm OD	3	
4	ISOLATION VALVE	BALL TYPE 1/2" SW X 1/2" NPT(F)	2	
4a	ISOLATION VALVE	BALL TYPE 1" SW	1	
5	PIPE	1/2" NB	A/R	
5a	PIPE	1" NB	A/R	
6	AIR MANIFOLD	2" NB	1	

NOTES.

- 1...ALL TUBE FITTINGS ARE OF DOUBLE COMPRESSION TYPE AND OF SS 316 MATERIAL.
- 2...QTY. SHOWN ARE TYPICAL FOR ONE INSTALLATION ONLY.
- 3...TUBE & FITTINGS MARKED ■ ARE INTEGRAL TO THE VALVE.
- 4...JUNCTION BOX WILL BE INTEGRAL TO ACTUATOR.
- 5...ISOLATION VALVE SHALL BE INSTALLED CLOSE TO THE VALVE ASSEMBLY.

PNEUMATIC SOV HOOK UP SCHEME

FOR TENDER PURPOSE ONLY

REV	DATE	PREPD	CHKD	APPVD	NATURE OF REVISION & DESCRIPTION
0	10.08.2018	AAM	AKP	AT	FIRST ISSUE
REVISION STATUS					

	OWNER: NLC TAMILNADU POWER LIMITED
PROJECT:	2x500 MW THERMAL POWER PLANT AT TUTICORIN
TITLE:	TYPICAL INSTRUMENT INSTALLATION DIAGRAM

	DEVELOPMENT CONSULTANTS PVT LTD. CONSULTING ENGINEERS KOLKATA • MUMBAI • CHENNAI • NEW DELHI		
PREPARED	AAM	JOB NO.	17A14
CHECKED	AKP	SCALE	NIL
APPROVED	AT	DATE	10.08.2018
DWG. NO.	17A14-DWG-I-0022		REV 0
			16 SHEETS OF 16

714945/2022/PS-PEM-MAX

Checklist for Serial Communication between maxDNA Systems and Foreign Device :BHEL

A Device Specific :

SN	Parameters	Options available	Remarks if any
1	Modle No.& Make of Device		
2	Communications Link Options	<input type="checkbox"/> Multidrop <input type="checkbox"/> Peer to Peer <input type="checkbox"/> N/w topology attached	
3	Protocol Mode (Device is a)	<input type="checkbox"/> Master <input type="checkbox"/> Slave <input type="checkbox"/> Master/Slave	
4	Protocol	<input type="checkbox"/> RTU <input type="checkbox"/> ASCII <input type="checkbox"/> Other -----	
5	Master	<input type="checkbox"/> System maxDNA <input type="checkbox"/> Other -----	
6	Redundancy Requirements	Yes / No	
7	Dist.bet.maxDNA System & Device*	<input type="checkbox"/> ----- Feet <input type="checkbox"/> ----- Meters	

B Electrical Specific :

1	Interface Type	<input type="checkbox"/> RS232 <input type="checkbox"/> RS422 <input type="checkbox"/> RS485	
2	Wiring at Device end	<input type="checkbox"/> 2 Wire <input type="checkbox"/> 4 Wire	
3	Transmission Channel	<input type="checkbox"/> Half Duplex <input type="checkbox"/> Full Duplex	
4	Baud Rates (bps)	<input type="checkbox"/> 1200 <input type="checkbox"/> 2400 <input type="checkbox"/> 4800 <input type="checkbox"/> 9600 <input type="checkbox"/> 19200	
5	Databits	<input type="checkbox"/> 8 <input type="checkbox"/> 7	
6	Stopbits	<input type="checkbox"/> 1 <input type="checkbox"/> 2	
7	Parity	<input type="checkbox"/> None <input type="checkbox"/> Odd <input type="checkbox"/> Even	
8	H/w & Software Handshake	<input type="checkbox"/> Yes <input type="checkbox"/> No	
9	Response Timeout time (Sec)	<input type="checkbox"/> ----- <input type="checkbox"/> Configurable timeout	
10	Data Formats Supported	<input type="checkbox"/> Boolean <input type="checkbox"/> Real <input type="checkbox"/> Char <input type="checkbox"/> Sn.Int <input type="checkbox"/> UnSn.Int	
11	Transmission mode	<input type="checkbox"/> Asynchronous <input type="checkbox"/> Synchronous	

C Application Specific : *

1	Primary Function*	<input type="checkbox"/> Data Acquisition <input type="checkbox"/> Data Acquisition & Control	
		<input type="checkbox"/> Download parameter sets	
2	Analog Points to read	-----Nos. <input type="checkbox"/> Details attached <input type="checkbox"/> Details not attached	
3	Analog Points to write	-----Nos. <input type="checkbox"/> Details attached <input type="checkbox"/> Details not attached	
4	Digital Points to read	-----Nos. <input type="checkbox"/> Details attached <input type="checkbox"/> Details not attached	
5	Digital Points to write	-----Nos. <input type="checkbox"/> Details attached <input type="checkbox"/> Details not attached	
6	Memory / Flag Points to read	-----Nos. <input type="checkbox"/> Details attached <input type="checkbox"/> Details not attached	
7	Memory / Flag Points to write	-----Nos. <input type="checkbox"/> Details attached <input type="checkbox"/> Details not attached	

D Hardware Specific :

1	Cable type	<input type="checkbox"/> Boolean cable <input type="checkbox"/> Twisted pair cable	
2	Cable Details Enclosed	<input type="checkbox"/> Yes <input type="checkbox"/> No	
3	Any specific Converter required	<input type="checkbox"/> Yes <input type="checkbox"/> No <input type="checkbox"/> Details enclosed	

E Device Documents :

1	Manufacturer's Documents*	<input type="checkbox"/> Tech., Spec. <input type="checkbox"/> Operating Manual	
---	---------------------------	---	--

***Notes:**

A6 To identify converter requirement and cable length.

C The sr.no.1 to 7 are reqd.to be furnished for interface impl. :such as Tagname,Description,point type, modbus(Register) address,EU,range & device (dlave) address

C1 What is the primary purpose of the communications link?

E1 Reqd. Contents : This document must provide an overview of the device including its intended use(a general technical,communication & electrical details)

STANDARD HARDWIRED INTERFACE BETWEEN COMPRESSOR CONTROL SYSTEM, DCS AND SWGR

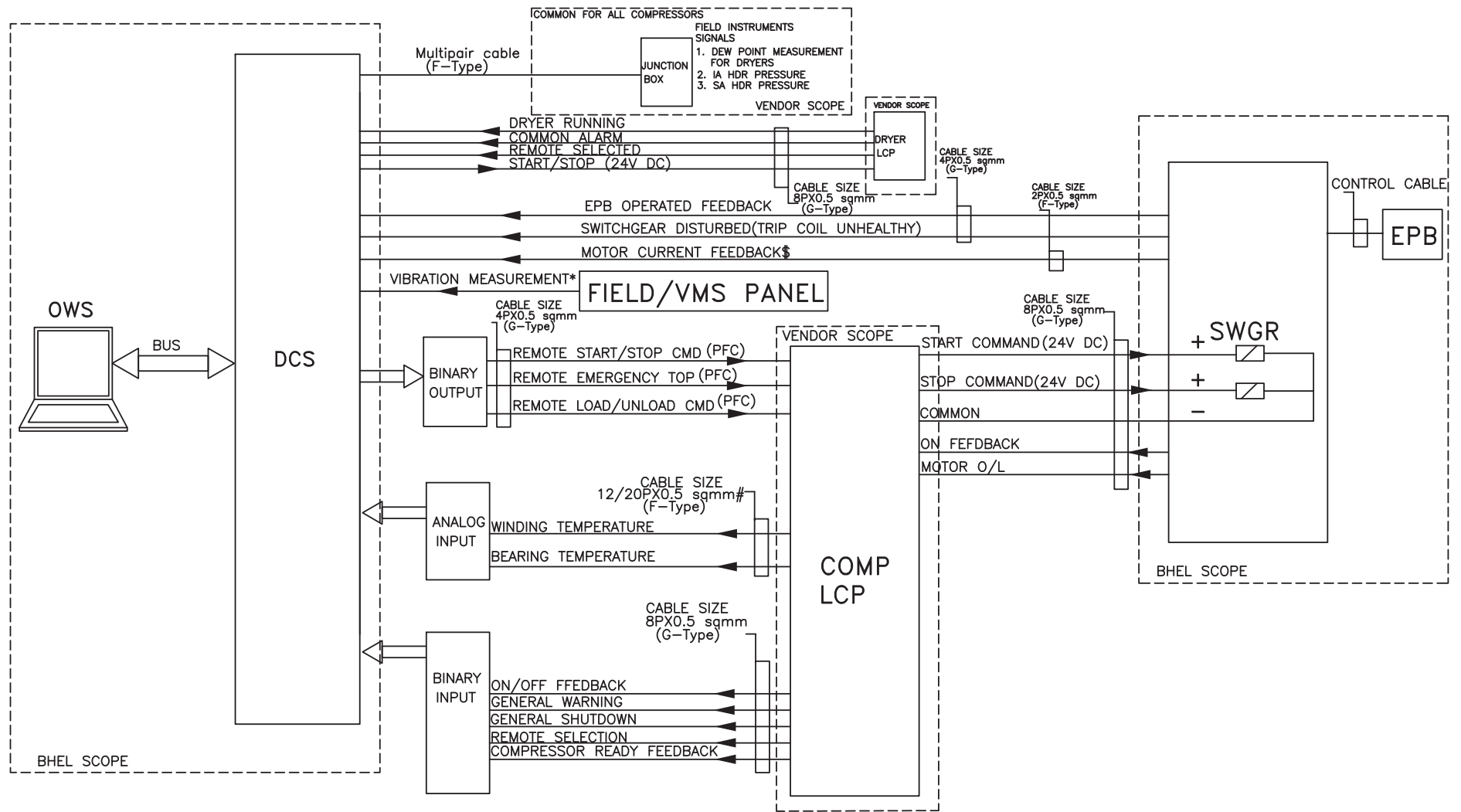

- NOTE:
- *APPLICABLE FOR HT MOTORS (PROJECT SPECIFIC)
 - #12P APPLICABLE IF 'TT' IS ENVISAGED. 20P APPLICABLE IF 'RTD' IS ENVISAGED.
 - \$FOR NTPC PROJECTS MIN 4P(F-TYPE) TO BE USED.
 - CABLE SCOPE SHALL BE AS PER ELECTRICAL SCOPE MATRIX OF PARTICULAR PROJECT



TITLE DDCMIS/LCP/SWGR INTERFACE FOR INDIVIDUAL COMPRESSOR/DRYER

C&I TECHNICAL SPECIFICATION FOR COMPRESSED AIR SYSTEM								
HARDWIRED SIGNALS BETWEEN COMPRESSOR CONTROL SYSTEM, DCS AND SWGR								
S. NO.	KKS TAG NO.	SOURCE	DESTINATION	DESCRIPTION	STATUS	I/O TYPE	SIGNAL TYPE	REMARKS
1	QEB10AN001	COMPRESSOR-1 LCP	DCS PANEL	COMPRESSOR-1 REMOTE SELECTION FEEDBACK	TRUE	DI	NO	
2	QEB10AN001			COMPRESSOR-1 GENERAL WARNING FEDABCK	TRUE	DI	NO	
3	QEB10AN001			COMPRESSOR-1 GENERAL SHUTDOWN FEDABCK	TRUE	DI	NO	
4	QEB10AN001			COMPRESSOR-1 ON/OFF (RUN) FEDABCK	TRUE	DI	NO	
5	QEB10AN001			COMPRESSOR-1 READY FEEDBACK	TRUE	DI	NO	
6	QEB10CT001-6*			COMPRESSOR-1 MOTOR WINDING TEMPERATURE (3/6nos.)*	--	AI	RTD/4-20mA***	
7	QEB10CT007-10			COMPRESSOR-1 MOTOR BEARING TEMPERATURE(4nos.)	--	AI	RTD/4-20mA***	
8	QEB10VT001-8**	FIELD/VMS PANEL	DCS PANEL	COMPRESSOR-1 MOTOR VIBRATIONS(8nos.)**	--	AI	4-20mA	As applicable
9	QEB10AN001	DCS PANEL	COMPRESSOR-1 LCP	COMPRESSOR-1 REMOTE LOAD/UNLOAD COMMAND	CMD	DO	NO	Maintained Type PFC
10	QEB10AN001			COMPRESSOR-1 REMOTE START/STOP COMMAND	START/STOP	DO	NO	Maintained Type PFC
11	QEB10AN001			COMPRESSOR-1 REMOTE EMERGENCY STOP	EMERG STOP	DO	NO	
12	QEB10AN001	COMPRESSOR-1 LCP	COMPRESSOR-1 SWGR	COMPRESSOR-1 START COMMAND	START	DO	NO	
13	QEB10AN001			COMPRESSOR-1 STOP COMMAND	STOP	DO	NO	
14	QEB10AN001	COMPRESSOR-1 SWGR	COMPRESSOR-1 LCP	COMPRESSOR-1 ON FEEDBACK	ON FB	DI	NO	
15	QEB10AN001			COMPRESSOR-1 MOTOR O/L	MTR O/L	DI	NO	
16	QEB10AN001	COMPRESSOR-1 SWGR	DCS PANEL	COMPRESSOR-1 EPB OPERATED	EPB OPTD	DI	NO	
17	QEB10AN001	COMPRESSOR-1 SWGR	DCS PANEL	COMPRESSOR-1 SWGR DISTURBED FEEDBACK	SWGR DIST	DI	NO	
18	QEB10CE001	COMPRESSOR-1 SWGR	DCS PANEL	COMPRESSOR-1 MOTOR CURRENT	--	AI	4-20mA	
19	QEB20AT001	DRYER-1 LCP	DCS PANEL	DRYER-1 REMOTE SELECTED	REMOTE	DI	NO	
20	QEB20AT001			DRYER-1 RUNNING	ON	DI	NO	
21	QEB20AT001			DRYER-1 COMMON ALARM	ALARM	DI	NO	
22	QEB20AT001	DCS PANEL	DRYER-1 LCP	DRYER-1 START/STOP COMMAND	START/STOP	DO	24V DC	
23	QED20DM001	JB	DCS PANEL	DEW POINT MEASUREMENTS FOR DRYERS	--	AI	4-20mA	
24	QED25CP001			IA HEADER PRESSURE	--	AI	4-20mA	
25	QED35CP001			SA HEADER PRESSURE	--	AI	4-20mA	
NOTE:					LEGENDS:			
1. *3nos. Of winding temperature applicable for NTPC projects.					DI-DIGITAL INPUT			
2. **Vibration signals are project specific & quantity/type depends upon VMS panel/Field outputs.					DO-DIGITAL OUTPUT			
3. ***If temp transmitter envisaged then 4-20mA applicable for winding/bearing temperature.					NO-NORMALLY OPEN			
4. This signal list is for one compressor & one dryer. Simillar signal list shall be applicable for other compressors/dryers also.					NC-NORMALLY CLOSED			

	DOCUMENT TITLE
	KKS NUMBERING PHILOSOPHY

KKS NUMBERING PHILOSOPHY

For identifying (tagging) an instrument / equipment in Power plant KKS numbering scheme is used. The purpose is to assign a unique number to every equipment in the power plant. For C&I equipment unique number are to be provided up to the signal level so that a unique number Input / Output exist in DCS for every signal.

Normally KKS number is a 10 digit alpha-numeric code and is typically split into the following:

X	X	X	A	A	Y	Y	B	B	B
---	---	---	---	---	---	---	---	---	---

First three digits indicate the Sub-System. The Code for the major system are given as per **Annexure-1**.

Fourth and Fifth digits are the **Numerical Keys at System Code Level** and used to distinguish between main systems having same Alpha Codes.

Sixth and Seventh digits are the **Equipment / Apparatus / Measuring Circuit Code**. The code of various Equipment / Apparatus / Measuring Circuit is shown in **Annexure-2**

Eight, Nine and tenth digits are the **Numerical Keys at Equipment / Apparatus / Measuring Circuit Code** and used to distinguish between various instruments in the same sub-group. Numerical keys at System / Equipment / Apparatus / Measuring Circuit is shown in **Annexure-3**.

DOCUMENT TITLE																						
	KKS NUMBERING PHILOSOPHY																					
CM	Humidity																					
CQ	Analysis (SWAS)																					
CS	Speed, Velocity, Frequency																					
CT	Temperature																					
CY	Vibration, Expansion																					
ANNEXURE-3																						
Numerical Keys																						
A) Numerical Keys at System Code Level																						
i) Use 10, 20, 30... To distinguish between main systems having same Alpha Codes. Examples:																						
a) Main Steam (Left) and Main Steam (Right)																						
b) BFP – A/B/C																						
c) ID Fan – A/B, FD Fan A/B, AH – A/B																						
ii) For branch off from main system path having code say 10, keep the same alpha code and use 11, 12, 13 etc. Similarly for other branch off from main system path having code say 20, keep the same alpha code and use 21, 22, 23 etc and shall carry on further in the same way.																						
iii) If the branch off from main system / sub system path is used for some other system, where different alpha codes can be applied, then in that case the said branch line will be designated by the alpha codes of the system to which it is providing the input.																						
B) Numerical keys at Equipment Code level:																						
There are three numerical keys available for each type of equipment code. Following has been agreed upon considering present practice, better flexibility and ease in sorting.																						
i) Valves and Dampers --- <i>Equipment Code – AA</i>																						
	<table border="0"> <thead> <tr> <th></th> <th style="text-align: center;"><u>N1</u></th> <th style="text-align: center;"><u>N2 N3</u></th> </tr> </thead> <tbody> <tr> <td>Motorised (<i>on/off duty</i>)</td> <td style="text-align: center;">0</td> <td style="text-align: center;">01 to 50</td> </tr> <tr> <td>Motorised (<i>inching duty</i>)</td> <td style="text-align: center;">0</td> <td style="text-align: center;">51 to 99</td> </tr> <tr> <td>Pneumatic (Control)</td> <td style="text-align: center;">1</td> <td style="text-align: center;">01 to 50</td> </tr> <tr> <td>Motorised (<i>thyrestor Control</i>)</td> <td style="text-align: center;">1</td> <td style="text-align: center;">51 to 99</td> </tr> <tr> <td>Sol. Operated (Open / Close duty (Valves, NRVs, Gate)</td> <td style="text-align: center;">2</td> <td style="text-align: center;">01 to 99</td> </tr> <tr> <td>Hydraulic</td> <td style="text-align: center;">3</td> <td style="text-align: center;">01 to 99</td> </tr> </tbody> </table>		<u>N1</u>	<u>N2 N3</u>	Motorised (<i>on/off duty</i>)	0	01 to 50	Motorised (<i>inching duty</i>)	0	51 to 99	Pneumatic (Control)	1	01 to 50	Motorised (<i>thyrestor Control</i>)	1	51 to 99	Sol. Operated (Open / Close duty (Valves, NRVs, Gate)	2	01 to 99	Hydraulic	3	01 to 99
	<u>N1</u>	<u>N2 N3</u>																				
Motorised (<i>on/off duty</i>)	0	01 to 50																				
Motorised (<i>inching duty</i>)	0	51 to 99																				
Pneumatic (Control)	1	01 to 50																				
Motorised (<i>thyrestor Control</i>)	1	51 to 99																				
Sol. Operated (Open / Close duty (Valves, NRVs, Gate)	2	01 to 99																				
Hydraulic	3	01 to 99																				

DOCUMENT TITLE																																																									
	KKS NUMBERING PHILOSOPHY																																																								

<table style="width: 100%; border-collapse: collapse;"> <tbody> <tr> <td style="width: 70%;">NRV (Without actuation)</td> <td style="width: 5%; text-align: center;">-</td> <td style="width: 10%; text-align: center;">4</td> <td style="width: 15%; text-align: center;">01 to 99</td> </tr> <tr> <td>Manual</td> <td style="text-align: center;">-</td> <td style="text-align: center;">5</td> <td style="text-align: center;">01 to 99</td> </tr> <tr> <td>Manual</td> <td style="text-align: center;">-</td> <td style="text-align: center;">6</td> <td style="text-align: center;">01 to 99</td> </tr> <tr> <td>Relief & Safety Valves</td> <td style="text-align: center;">-</td> <td style="text-align: center;">7</td> <td style="text-align: center;">01 to 99</td> </tr> <tr> <td>Reserve</td> <td style="text-align: center;">-</td> <td style="text-align: center;">8</td> <td style="text-align: center;">01 to 99</td> </tr> <tr> <td>Reserve</td> <td style="text-align: center;">-</td> <td style="text-align: center;">9</td> <td style="text-align: center;">01 to 99</td> </tr> <tr> <td colspan="4"> </td> </tr> <tr> <td colspan="4">ii) Field Instruments</td> </tr> <tr> <td>Field Transmitters & Analog Signals</td> <td style="text-align: center;">-</td> <td style="text-align: center;">0</td> <td style="text-align: center;">01 to 99</td> </tr> <tr> <td>Field Switches & Binary Signals</td> <td style="text-align: center;">-</td> <td style="text-align: center;">1</td> <td style="text-align: center;">00 to 99</td> </tr> <tr> <td>PG Test Point</td> <td style="text-align: center;">-</td> <td style="text-align: center;">4</td> <td style="text-align: center;">00 to 99</td> </tr> <tr> <td>Gauges</td> <td style="text-align: center;">-</td> <td style="text-align: center;">5</td> <td style="text-align: center;">00 to 99</td> </tr> <tr> <td>Automatic Turbine Tester (ATT)-HWR</td> <td style="text-align: center;">-</td> <td style="text-align: center;">2</td> <td style="text-align: center;">00 to 99</td> </tr> <tr> <td colspan="4">(Reserved for protection Signals used by Hardwar)</td> </tr> </tbody> </table>	NRV (Without actuation)	-	4	01 to 99	Manual	-	5	01 to 99	Manual	-	6	01 to 99	Relief & Safety Valves	-	7	01 to 99	Reserve	-	8	01 to 99	Reserve	-	9	01 to 99	 				ii) Field Instruments				Field Transmitters & Analog Signals	-	0	01 to 99	Field Switches & Binary Signals	-	1	00 to 99	PG Test Point	-	4	00 to 99	Gauges	-	5	00 to 99	Automatic Turbine Tester (ATT)-HWR	-	2	00 to 99	(Reserved for protection Signals used by Hardwar)				
NRV (Without actuation)	-	4	01 to 99																																																						
Manual	-	5	01 to 99																																																						
Manual	-	6	01 to 99																																																						
Relief & Safety Valves	-	7	01 to 99																																																						
Reserve	-	8	01 to 99																																																						
Reserve	-	9	01 to 99																																																						
ii) Field Instruments																																																									
Field Transmitters & Analog Signals	-	0	01 to 99																																																						
Field Switches & Binary Signals	-	1	00 to 99																																																						
PG Test Point	-	4	00 to 99																																																						
Gauges	-	5	00 to 99																																																						
Automatic Turbine Tester (ATT)-HWR	-	2	00 to 99																																																						
(Reserved for protection Signals used by Hardwar)																																																									
Example of Numerical Key Usage:																																																									
<p>In line with the philosophy adopted for Valves / Dampers /instruments etc. pumps and fans in the main systems (having different system code) can be numbered as AP/N100 and as AP/N101, 102, Where system code is same.</p>																																																									

	2X500 MW NTPL TUTICORIN FGD COMPRESSED AIR SYSTEM	SPECIFICATION NO. PE-TS-483-555-A002	
		VOLUME : II B	
		SECTION : E / ANNEXURE-I	
		REV 00	DATE: FEB 2022
		SHEET: 1 OF 1	

ANNEXURE-I

LIST OF MAKES OF SUB-VENDOR ITEMS

CAS SUB-VENDOR LIST.xls

		SUB VENDOR LIST & INSPECTION CATEGORISATION (ANNEXURE- II)				
COMPRESSED AIR SYSTEM						
SL No	Item	QP / Insp.Cat	Proposed Subvender	Place of Manufacturer	Technical Limit	Remarks
1	AIR DRYING PLANT (HOC TYPE)	I	ACIL	BELGIUM	ROTARY DRUM	Testing at Atlas Copco Works Pune
			MELLCON	Delhi	Twin Tower type	
			DELAIR	Gurgaon	Twin Tower type	
			SUMMITS	Coimbtore	Twin Tower type	
			Shakot	Noida	Twin Tower type	
2	AIR DRYING PLANT (REFRIGERANT TYPE)	I	ACIL	BELGIUM		
			MELLCON	Delhi		
			DELAIR	Gurgaon		
			SUMMITS	Coimbtore		
			Shakot	Noida		
			Savroe	Germany		
			MTA	Italy		
			Dominic Hunter	U.K		
3	MS/GI Pipes —ERW IS 1239 / IS 3589	III	SAIL	Rourkela		1) Quantity < 200 meters Assorted sizes) 2) Material will be accepted on the basis of Main contractor COC supported by manufacturer TC as per relevant Code. In addition to above main contractor will certify availability of correlated identification marks on pipe wrt Manf TC and will also certify that pipes are free from rust
			Jindal	Ghaziabad/Hissar	upto 350NB	
			Surya Roshni	Bahadurgarh	upto 400 NB	
			Tata IS 1239 Pipes	Jamshedpur	upto 150NB	
			Maharshtra seamless IS 3589	Raigad	200 to 500 NB	
			PSL	Chennai/Vizag/Kutch/Daman	Spiral Weld SAW as per IS 3589	
			Lalit Profile	Thane	Spiral Weld SAW as per IS 3589	
			Samshi Pipes Industries	Vadodara	Spiral Weld SAW as per IS 3589	
			Mukut Pipes	Rajpura	Longitudinal SAW (Single side weld) as per IS 3589	
			Indus Tubes	G B Nagar	Upto 300 NB ERW Pipes as per IS 1239/3589	
			Mann Ind	Indore	Spiral Weld SAW as per IS 3589	
			Surendra Engg	Rajpura	Spiral Weld SAW as per IS 3589	

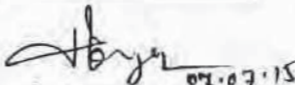
 07.07.15
 (Harish Kumar)

CAS SUB-VENDOR LIST.xls

SL No	Item	QP / Insp.Cat	Proposed Subvendor	Place of Manufacturer	Technical Limit	Remarks
			Pratibha Pipes & Structure Pvt Ltd	Thane	Spiral Weld SAW as per IS 3589	
			JCO Gas Pipe	Chindwara	Spiral Weld SAW as per IS 3589	
			Nukat Tanks and Vessels	Tarapur	Longitudinal SAW (Single side weld) as per IS 3589	
			DADU Pipes	Sikandrabad	Upto 300 NB ERW Pipes as per IS 1239/3589	
			Good Luck Tubes	Sikandrabad	Upto 300 NB	
			Advance Steel Tubes	Sahibabad	Upto 300 NB	
			APL APPOLO Tubes	Sikandrabad	Upto 300 NB	
			Hi Tech Pipes	Sikandrabad	Upto 300 NB	
			Ratnamani	Kutch/Ahmedabad/Chhatral	Upto 400 NB ERW Pipes as per IS 3589 and SAW as per IS 3589	
			Welspun	Anjar/Bharuch	Upto 400 NB ERW Pipes as per IS 1239/3589 and SAW as per IS 3589	
4	Forged/formed fittings	III	EBY	Taloja		
			Siddarth & Gautam	Faridabad		
			Pipefit	Baroda		
			MS Fittings	Kolkata		
			Tube Products	Baroda		
			Bharat Forge	Pune		
			NL Hazra	Kolkata		
5	Ball Valve	I	Precision Engg	Nasik	upto 400NB 150 class	
			Microfinish Valves Ltd	Hubli		
			Weir BDK engg Industries	NEW DELHI		
			Flow chem. Industries	Ahermdabad	upto 50 NB 800 Class; 350NB 150 class	
			Audco	Chennai		
			Akay India	Hubli	upto 50NB 800 class	
			A V Valves	Agra		
			Asian Industrial valves & Instruments Ltd	Chennai		
			ATAM Valves	Jalandhar	(1) BALL VALVES: FCS/FSS - 1/2" to 2" #800 & CCS/CSS - 2, 1/2" to 4" # 150 (2) BALL VALVES: CUN METAL VALVES: SIZE 15 NB TO 80 NB - UPTO PN16.0	
			GM ENGINEERING	Rajkot		
			Hawa Valves (India) Pvt. Ltd.	Navi Mumbai	Size up to 2" & #800 with MOC as FCS & FSS and for size from 65 NB to 150 NB & #150 with MOC as CCS and CSS.	

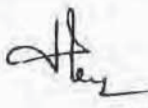
 07.07.15
 (Harish Kumar)

CAS SUB-VENDOR LIST.xls

SL No	Item	QP / Insp.Cat	Proposed Subvendor	Place of Manufacturer	Technical Limit	Remarks
			INTERVALVE (INDIA) LTD.	Pune	Steel ball Valves upto 50NB, #800 and 65NB to 150NB #150	
			NILON VALVES PRIVATE LIMITED	Ahmedabad		
			LEADER VALVES LTD.	Jalandhar	CAST STEEL UPTO 200 MM, CLASS 150/300.	
			DEMBLA VALVES LTD.	Thane		
			SURYA VALVES AND INSTRUMENTS MFG CO.	Chennai	FOR CARBON STEEL/STAINLESS STEEL UPTO SIZE 200NB.	
			UNIFLOW	Chennai		
			VALTECH INDUSTRIES	Mumbai	FORGED CARBON & ALLOY STEEL BALL VALVES ,SCREWED TYPE BALL VALVES RATING 800 , SIZES UPTO 50 & CC& ALLOY STEEL BALL VALVES RATING 150 , SIZES 65 TO 200 FLANGED TYPE.	
			VAAS AUTOMATION	NEW DELHI		
			Belgaum Aqua Valve	Belgaum		
6	CS/FS Gate/Globe/Check valves	III	Fouress	Mumbai/ Aurangabad		
			Weir BDK	NEW DELHI		
			L & T Valves	Coimbatore/ Kancheepuram		
			Leader	Jalandhar		
			KSB	Coimbatore		
			A V Valves	Agra		
			ATAM Valves	Jalandhar	(1) Carbon Steel Gate Valves & non return valves: 15 NB to 50 NB (#800) & 65 NB to 300 NB (#150) (2) Carbon Steel Globe Valves: 15 NB to 50 NB (#800) & 65 NB to 200 NB (#150)	
			Fluidline valves	Ghaziabad		
			GM ENGINEERING	Rajkot		
			INTERVALVE (INDIA) LTD.	Pune	a) Steel Gate Valves: upto 50NB, #800 and 65NB to 150NB, #150 b) Steel Globe Valves: upto 50NB, #800 and 65NB to 100NB, #150 c)Supplier not registered for NR Valves	
			Niton Valves	Mumbai		
			NSSL Ltd.	Nagpur		
			Steel Strong valves Ltd.	Navi Mumbai		

Harish Kumar
07.07.15
(Harish Kumar)

GAS SUB-VENDOR LIST.xls

SL No	Item	QP / Insp.Cat	Proposed Subvendor	Place of Manufacturer	Technical Limit	Remarks
			VENUS PUMPS AND ENGG. WORKS	Kolkata	CC/CSS-GATE-BBT-UPTO600NB CL UPTO300,GATE-PSBT UPTO250NB CL 1500,GLV-BBT-UPTO300NB CL UPTO600,SCNRV-BBT-UPTO600NB CL UPTO150,SCNRV-BBT-UPTO300NB CL 300,SCNRV-PSBT-UPTO150NB CL UPTO900	
			VALTECH INDUSTRIES	Mumbai	CAST CARBON & ALLOY STEEL - VALVE/RATING/SIZE- GV/150/900,GV/300/400, GV/600/300, GV/GLV/NRV/900/250, GLV/300/300,GLV/150/350, SCNRV/150/700, SCNRV/300/350, SCNRV/600/250.	
			V K Valves Ltd.	Jalandhar		
			KBL	Kondhapuri		
7	Butterfly Valve	II	KBL	Kondhapuri		
			Fouress	Bangalore		
			Audco	Chennai		
			Weir BDK	NEW DELHI		
			Tyco	Halol		
			Inter Valve	Pune		
			Advance Valves	Noida		
			Fluidline valves	Ghaziabad		
			Instrumentation Ltd.	Palakkad		
			R and D Multiples (Metal Cast) Pvt. Ltd.	Mumbai		
			SURYA VALVES AND INSTRUMENTS MFG CO.	Chennai	FOR CI , CCS & CSS UPTO SIZE 750 NB	
			PENTAIR VALVES AND CONTROLS INDIA PRIVATE LIMITED	Navi Mumbai		
			UPADHAYA VALVES MANUFACTURERS PRIVATE LIMITED,	Kolkata	MOC-Cast Iron, size from 65 NB to 350 NB having rating of PN10 as per BS EN 593.	
			VENUS PUMPS AND ENGG. WORKS	Kolkata		

Handwritten signature
07-07-15
(Harish Kumar)

CAS SUB-VENDOR LIST.xls

SL No	Item	QP / Insp.Cat	Proposed Subvendor	Place of Manufacturer	Technical Limit	Remarks
8	Air Receiver	I	Integrated Engineers	Mumbai		
			Diamond Fabricators	Pune		
			Parkaire	Delhi		
			Temasme Vesselex	Noida		
			United Engineering Works	Nasik		
9	Safety Relief Valve	III	LEADER	JALANDHAR		
			SPIRAX MARSHALL	PUNE		
			FISCHER SANMAR	CHENNAI		
10	Pr./Vacuum/Dp Gauges	III	Auxitrol	U.K		
			Switzer (for DP gauge)	Chennai		
			Budenburg	U.K		
			A.N.Instruments	Kolkata		
			Bells Control	Kolkata		
			Manometer India	Mumbai		
			H Guru Industries	Kolkata		
			Ashcroft India	Kalol		
			General Inst.	Mumbai/Goa		
			Gluck India	Mumbai		
			BOSE PANDA INSTRUMENTS PVT.LTD.	Kolkata		
			Forbs Marshall	Hyderabad		
			Gauge Bourdon	Mumbai		
			H Guru Instruments	Bangalore		
Baumer Technologies	Mumbai					
11	Pr./Vacuum/DP.switch	III	Barton Inst.system	USA		* If the total Quantity is <= 10, then inspection category III. However, manufacturer TC to be submitted
			Indfoss	Ghaziabad		
			SOR	USA		
			Dressor	USA		
			Delta control	UK		
			Trafag	Ranipet		
			GiC(Gauges Bourdon)	Parvel		
			ASHCROFT INDIA PVT LTD.	USA/GERMANY		
			Switzer	Chennai		
12	Temperature Gauge	III	Budenburg	U.K		
			A.N.Instruments	Kolkata		
			Bells Control	Kolkata		
			H Guru Industries	Kolkata		
			General Inst.	Mumbai/Goa		
			H Guru Instruments	Bangalore		
			Forbs Marshall	Hyderabad		
			Goa Instruments	Goa		
			Goa Thermostatics Instruments Pvt. Ltd.	Goa		
			Gauge Bourdon	Mumbai		
			Baumer Technologies	Mumbai		

Harish
07.07.22
(Harish Kumar)

CAS SUB-VENDOR LIST.xls

SL No	Item	QP / Insp.Cat	Proposed Subvendor	Place of Manufacturer	Technical Limit	Remarks
			Ashcroft India	Kalol		
13	Transmitters (PT, TT, DPT, LT)	II	ABB	Fandabad	PRESSURE TRANSMITTER, DP TRANSMITTER and TEMP TRANSMITTER	* if the total Quantity is <= 10, then inspection category III. However, manufacturer TC to be submitted
			Yokogawa	Bangalore		
			Emerson	Mumbai		
			(ABB) -2600T series	Fandabad/Italy		
			Pune Techrol Pvt. Ltd.	Pune	Only for capacitance Type Level Transmitter	
			SIEMENS LIMITED	Mumbai		
			SMART INSTRUMENTS LTD, BRAZIL	Mumbai	LD-301 & T-301 TRANSMITTER FROM M/S SMART EQUIPMENTS BRAZIL.	
			SBEM PVT. LTD.	Pune	Only for capacitance Type Level Transmitter	
			TOSHNIWAL INDUSTRIES PVT. LTD.,	Ajmer		
			V. AUTOMAT & INSTRUMENTS (P) LTD.	NEW DELHI	a)DISPLACEMENT TYPE TRANSMITTERS. b)PRESSURE AND DP TRANSMITTERS	
			Honeywell Automation	NEW DELHI		
			Fuji	Japan		
			NIVO CONTROLS PVT. LTD.	Indore	For Capacitance type only	
			Moore Industries International Inc.	CALIFORNIA, USA	Indian Associate - Chemtrol	
			Endress + Hauser (India) Pvt. Ltd.,	NEW DELHI	TEMP TRANSMITTER ONLY	
14	HT Motor for Air compressor	I	CGL	Mandideep	Upto 1600 KW, 6.6 KV; Upto 1310 KW, 11 KV	
			Marathon Electric	Kolkata	Upto 6.6 KV, 750 KW	
			BHEL	Bhopal		
			SIEMENS	Germany		
			Hyosung	Korea		
			Hyundai	Korea		
15	Flow Switch	III	Switzer	Chennai		
			Levecon	Kolkata		
			DK Instruments	Kolkata		
			Delta	UK		
			ITT Barton	USA		
16	Temp Sensor	III	Pyro Electric	Mumbai		
			Detrv	Mumbai		
17	Flow Indicator	III	Sigma	Mumbai		
			Eureca	Pune		
18	Auto Drain Trap	III	Pennant	Pune		
			Forbes Marshall	Pune		
19	Dew point meter	III	GE Sensing	Ireland		

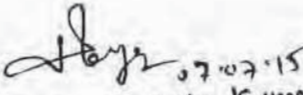
 07.07.15
 (Haish Kumar)

CAS SUB-VENDOR LIST.xls

SL No	Item	QP / Insp.Cat	Proposed Subvendor	Place of Manufacturer	Technical Limit	Remarks
			Michell Instruments	UK		
			XENTAUR	USA		
			Shaw	UK		
20	Flow Meter / Rota Meter	III	Trac	Hyderabad		
			Eureca	Pune	Rota Meter only	
			Flow Star Engg.	Fardabad	Rota Meter only	
			Flow Tech instruments	Vadodara	Rota Meter only	
			Instruments Engineers Pvt. Ltd.	Hyderabad	Rota Meter only	
			Scientific Devices (Bombay) Pvt. Ltd.	Mumbai	Rota Meter only	
			Emerson Process Management	singapore	Vortex Type	
			ABB Ltd.	India	Vortex Type	
			Krohne Marshall Pvt. Ltd.	India	Vortex Type	
			Endress + Hauser (I) Pvt. Ltd.	India	Vortex Type	
			Yokogawa Electric Corporation (other than high temp & h2 services)	japan	Vortex Type	
			Krohne Messtechnik GmbH & Co. Kg	Germany	Vortex Type	
21	Level Indicator/ Gauge	III	Flow Star	Fardabad		
			Scientific Devices	Mumbai		
			Gauges Bourden	Parvel		
			SBEM	Pune		
			Pune Techtrol	Pune		
			Levcon	Kolkata		
			Sigma	Mumbai		
			V-Automat	New Delhi		
			DK Instruments	Kolkata		
22	Solenoid Valve	III	HERION	GERMANY/ ITALY		
			ROTEX AUTOMATION LTD.	V V NAGAR/ BARODA		
			ASCO	CHENNAI		
			JEFFERSON	ARGENTINA		
			AVCON	MUMBAI		
23	Cable trays (max 300 meters)	III	INAR PROFILE	ANNAKAPALLI		
			ANAND UDYOG	THANE		
			MJ ENGG.	DELHI		
			INDIANA	MUMBAI		Galvanizing. At Karnataka
			TECHNO ENGG	CHANDIGARH		
			JAMUNA METAL	DELHI		

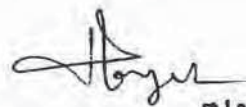
 7/7/15
 Harish Kumar

CAS SUB-VENDOR LIST.xls

SL No	Item	QP / Insp.Cat	Proposed Subvendor	Place of Manufacturer	Technical Limit	Remarks
			INDUSTRIAL PERFORATION	KOLKATA		Galvanizing at Unistar
			VATCO	MUMBAI		Galvanizing At Sigma Mumbai
24	Cable Glands	III	SUNIL & COMPANY	KOLKATA		
			ARUP ENGG	KOLKATA		
			COMMET	MUMBAI		
			QUALITY PRECISION	KOLKATA		
25	Cable Lugs	III	DOWELLS	MUMBAI		
			CHETNA ENGG	NASIK		
			3D	VALSAD		
26	DC LEAD ACID/NI-CD BATTERY	III	AMCO SAFT INDIA LTD	BANGALORE	Ni-Cd batteries only	
			EXIDE INDUSTRIES LTD	NEW DELHI	Lead Acid batteries only.	
			HBL POWER SYSTEMS LTD	Hyderabad	Ni/Cd and TUBULAR TYPE for Lead acid	
			HOPPECKE BATTERIEN GMBH & CO.KG.	Germany		
27	DC Battery Charger (for PLC Panel)	III	AMARA RAJA POWER SYSTEMS LIMITED	Tirupati		
			CHHABI ELECTRICALS PVT.LTD.	Jalgaon		
			CHLORIDE POWER SYSTEMS & SOLUTIONS LIMITED	Kolkata		
			DUBAS ENGG PVT LTD	BANGALORE		
			HBL POWER SYSTEMS	Hyderabad		
			JEMA ENERGY	Spain	For Static SCR Type Full Wave fully Control type	
			MASS-TECH CONTROLS PVT.LTD.	Mumbai		
			STATCON POWER CONTROLS LTD	Noida		
28	INSTRUMENT FITTINGS	III	AURA INCORPORATED	NEW DELHI		
			Astec Valves & Fittings Pvt. Ltd.,	Mumbai		
			Arya Crafts & Engineering Pvt. Ltd.	Mumbai		
			Comfit & Valve Pvt. Ltd.	Nandasan-Gujarat		
			FLUIDFIT ENGINEERS PVT. LTD.	Mumbai		
			Fluid Controls Pvt. Ltd.	Mumbai		
			HP VALVES & FITTINGS INDIA PVT. LTD.	Chennai		
			PRECISION ENGINEERING INDUSTRIES	Mumbai		
			Panam Engineers,	Mumbai		
			Perfect Instrumentation Control (India) Pvt. Ltd.	Mumbai		
			VIKAS INDUSTRIAL PRODUCTS	Noida		
29	SS Pipes	III	REMI	Mumbai		
			Ratmani	Ahmedabad		
			Apex Tubes	Behror		
			Choksi	Ahmedabad		
30	UPS	III	HITACHI-HIREL	Gandhinagar		
			APC	Bangalore		
			Delta	Gurgaon		
			Emerson	Mumbai		
			DB Power	Pune		
			Aplab	Mumbai		

Handwritten signature and date:
 21/11/22
 Harish Kumar

CAS SUB-VENDOR LIST.xls

SL No	Item	QP / Insp.Cat	Proposed Subvendor	Place of Manufacturer	Technical Limit	Remarks
31	OWS/PC	III	HP/Compaq /Dell/HCL/IBM/lenovo			
32	Printer	III	HP/Cannon/Epson/Xerox/IBM /Lexmark			
33	PLC Based Panels	I	SIEMENS	Nasik		
			SCHNEIDER	Nasik		
			ROCKWELL	Sahibabad		
			GE Intelligent Platform	BANGALORE		
			Honeywell Automation India Limited ,	Pune		
	ABB	Bangalore				
34	Fibre Optic Cable	III	Birta Ericsson	Rewa		
			Finolex	Pune/Goa		
			Aksh Fibre	Bhiwadi		
35	Junction Box	III	AJMERA INDUSTRIAL &	Mumbai	For galvanised & FRP Junction	
			FLEXPRO ELECTRICALS	Navsan, Gujarat	Metal type Junction boxes only	
			K.S. INSTRUMENTS	Bangalore		
			SUCHITRA INDUSTRIES	Bangalore		
			Shrenik & Company,	Ahemdabad		
36	PAINTS	III	Asian Paints (I) Ltd.	Mumbai		
			Berger Paints India Ltd	Delhi		
			Goodlass Nerolac	Mumbai		
			Jenson & Nicholson (I) Ltd	Gurgaon		
			CDC carboline (I) Ltd.	Delhi		
			Shalimar Paints Ltd.	Gurgaon		
			Addison Paints Ltd	Chennai		
			Grand Polycoat	Mumbai		
			Bombay Paints	Mumbai		
			Jotun Paints	Pune		
			Hemple Paints	Singapore		

NOTES:

1) INSP CAT I : FOR THOSE ITEMS THE QUALITY PLANS ARE APPROVED BY CUSTOMER AND FINAL ACCEPTANCE WILL BE ON PHYSICAL INSPECTION WITNESS BY BHEL & CUSTOMER.

2) INSP CAT II : FOR THOSE ITEMS THE QUALITY PLANS ARE APPROVED BY CUSTOMER, HOWEVER NO PHYSICAL INSPECTION WILL BE DONE BY BHEL / CUSTOMER. THE FINAL ACCEPTANCE BY BHEL / CUSTOMER SHALL BE ON THE BASIS OF REVIEW OF DOCUMENTS AS PER QP.

3) INSP CAT III : FOR THOSE ITEMS FINAL ACCEPTANCE BY BHEL / CUSTOMER BASED ON BIDDER'S COC.

4) THE ABOVE SUB VENDOR LIST IS INDICATIVE ONLY AND IS SUBJECT TO APPROVAL/ACCEPTANCE BY CUSTOMER/BHEL. BIDDER TO PROPOSE HIS SUB VENDOR LIST WITH BACK UP DOCUMENTS (EXPERIENCE LIST, END USER CERTIFICATE AS APPLICABLE) WHICH WILL SUBJECT TO BHEL AND CUSTOMER APPROVAL DURING DETAILED ENGINEERING STAGE WITHOUT ANY TECHNICAL , COMMERCIAL AND DELIVERY IMPLICATION TO BHEL/CUSTOMER.

Harish Kumar
7/7/15
(Harish Kumar)

APPENDIX... P.....
PAGE... 9... OF... 26.

SR NO	ITEM	QP /INS -PN CAT *	QP NO.	QP SUB-MISSION SCHEDULE	QP APPL SCHEDULE	PROPOSED SUB SUPPLIER	PLACE	SS APPL STATUS / CAT	SS DETAIL SUB-SCHEDULE	SC APPL SCHEDULE	REMARKS
13	SCREENED CABLES	1				DELTON	FARIDABA D	A			
		1				THERMO CABLES	HYDERABA D	A			
		1				CORDS	BHIWADI /KAHARANI	A			
		1				POLYCAB	DAMAN	A			
		1				INCAB	PUNE	A			
		1				ELKAY TELELINKS	FARIDABA D	A			
		1				KEI	BHIWADI	A			
		1				CMI	FARIDABA D	DR			
		1				RELIANCE ENGRS LTD	BANGALOR E	DR*			
14	AUXILIARY CONTROL PANEL					REFER SEPARATE LIST					
15	LT MOTORS (Refer Note 1)	1				KEC	BANGALOR E/HUBLI	A			(HUBLI UPTO 90 KW ,RQP)For Flame Proof also
		1				NGEF	HUBLI	A			UP TO 15 KW ONLY.
		1				CGL	AHMEDNAGAR	A			RQP,For Flame Proof also
		1				MARATHON ELEC. INDIA LTD	KOLKATA	A			RQP,For Flame Proof also
		1				JYOTI	VADODARA	A			
		1				BBL	MUMBAI	A			RQP,upto 160 KW only,For Flame Proof also
		1				LAXMI HYDRAULIC PVT. LTD	SHOLAPUR	A			upto 120 KW
		1				ABB	FARIDABA D/BANGALORE	A			RQP. Faridabnd upto 55 KW Bangalore above 55

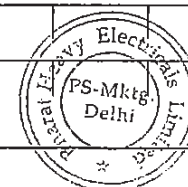

Signature

ENGINEERING DIV / QAI

APPENDIX B
PAGE 06 OF 20

SR NO	ITEM	QP /INS- -PN CAT *	QP NO.	QP SUB- MISSION SCHEDU -LE	QP APPL SCHED ULE	PROPOSED SUB SUPPLIER	PLACE	SS APPL STATUS / CAT	SS DETAIL SUB- SCHED ULE	SC APPL SCHED ULE	REMARKS
15	LT MOTORS (Refer Note 1)	I				SIEMENS	MUMBAI	A			RQP
16	ELECTRICAL ACTUATOR(WITH GEAR BOX ALSO)	II	QVI-Q-078			HAROLD BECK	GERMANY	A			
		II				DREHMO	GERMANY	A			
		II				AUMA	GERMANY	A			
		II				ROTORK	CHENNAI/B ANGALORE	A			
		II				ROTORK	UK	A			
		II				NIPPON GEAR	JAPAN	A			
		II				LIMITORQUE	USA	A			
		II				LIMITORQUE	FARIDABA D	A			
		II				AUMA INDIA	BANGLORE	A			
17	CABLE TRAY & ACCESSORIES					REFER SEPARATE LIST					
18	FLEXIBLE CABLE TRAY SUPPORT					REFER SEPARATE LIST					
19	CABLE GLANDS					REFER SEPARATE LIST					
20	CABLE LUGS					REFER SEPARATE LIST					
21	GEARED MOTOR	III				KIRLOSKAR ELEC LTD	HUBLI/BAN GALORE	A			
		III				NEW ALLENBERRY WORKS	KOLKATTA	A			
		III				SHANTI GEARS LTD	COIMBATO RE	A			
		III				POWER BUILD	VV NAGAR	A			
		III				LAXMI HYDRAULIC PVT. LTD	SHOLAPUR	A			

APPROVED
02/08/2011

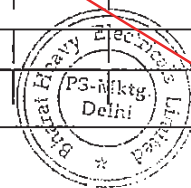

Signature

ENGINEERING DIV / QAI

A

122

MS

SW

A

(S)

h

Signature

SR NO	ITEM	QP /INS- -PN CAT *	QP NO.	QP SUB- MISSION SCHEDU -LE	QP APPL SCHED ULE	PROPOSED SUB SUPPLIER	PLACE	SS APPL STATUS / CAT	SS DETAIL SUB- SCHED ULE	SC APPL SCHED ULE	REMARKS
-------	------	-----------------------------	--------	-------------------------------------	----------------------------	--------------------------	-------	-------------------------------	--------------------------------------	----------------------------	---------

APPENDIX B
PAGE 102 OF 291

.Note1 : a) Acceptance of Motor less than 30 KW is based on COC of the manufacturer and the contractor confirming as follows: It is hereby confirmed that the above mentioned motor /motors was/ were manufactured taking care of NTPC specific requirements regarding ambient temp. voltage and frequency variation, hot starts, pull out torque, starting KVA/KW, temp. rise, distance between centre of stud and gland plate and tested in accordance with approved drawing /data sheets b) 30 KW and above Acceptance of Motor rating between 30 KW 50 KW is based on NTPC review of Routine Test inspection report as per IS 325 witnessed by main contractor along with COC of the manufacturer and the contractor confirming as follows: It is hereby confirmed that the above mentioned motor /motors was/ were manufactured taking care of NTPC specific requirements regarding ambient temp., voltage and frequency variation, hot starts, pull out torque, starting KVA/KW, temp. rise, distance between centre of stud and gland plate, space heater and tested in accordance with approved drawing /data sheets. Above 50 KW up to 200 KW NTPC inspection as per approved QP Note 2: Misc Items like name plate, wire marker, clamps and pads for thermocouple adaptor, unlon, cross, socket and plug, pneumatic fittings tubes shall be as per BHEL system

124

(S.N. T. J. S.)

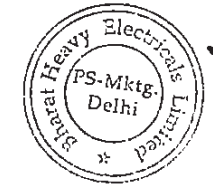

Signature

ENGINEERING DIV / QAI

ANNEXURE-I

SR. NO.	ITEM	QAP / INSP. CAT	QAP NO.	PROPOSED SUB SUPPLIER	PLACE OF MANUFACTURING	NTPC DOC NO	REMARKS
						REV. NO.	
PROJECT: NORTH KARANPURA STPP (3X660 MW)		LIST OF ITEMS REQUIRING QUALITY PLAN AND SUB- SUPPLIER APPROVAL				NTPC DOC NO	
PACKAGE: EPC PACKAGE						REV. NO.	0
MAIN SUPPLIER: BHEL		SUB SYSTEM: CIVIL WORKS				DATE	16.12.2013
CONTRACT NO.: CS-4410-001-2							
	PREPAINTED COIL COATED STEEL SYSTEM			INTERARCH	NOIDA	N	
				LLOYD INSULATION	-	N	
				MG INDUSTRIES	FARIDABAD	N	
				ARM STRONG	NEW DELHI	N	
9.	PAINT AND PAINTING SYSTEM	III	-	BERGER	-	N	
				SHALIMAR PAINTS	-	N	
				JENSON AND NICHOLSON	-	N	
				KANSAI NEROLAC	-	N	
				AKZO NOBEL	-	N	
				ASIAN PAINTS	-	N	
10.	COLOUR COATED SHEET (FOR COIL)	I	-	UNION STEEL	KOREA	A	
				DONGBU STEEL	KOREA	A	
				BHUSHAN STEEL AND STRIPS LTD.	RAIGAD	A	
				ESSAR STEEL LTD	PUNE	A	
				NATIONAL STEEL AND AGRO	DHAR	A	
				JSW STEEL COATED PRODUCTS LTD	KAMLESHWAR	A	Formerly JSW ISPAT Steel Ltd
				BHUSHAN STEEL LTD.	SAHIBABAD	A	
				JSW LTD	THANE	A	
				TATA BLUESCOPE STEEL LTD	JAMSHEDPUR	A	*AL-ZN COIL FOR CLADDING
	PROFILERS FOR DECKING SHEETS	I		UNIMET PROFILES LIMITED	DHARUHERA	A	
				MULTICOLOUR STEEL INDIA LIMITED	GURGAON	A	
				ISOLLOYD	SOLAN	A	
				NATIONAL STEEL AND	DHAR	A	

041

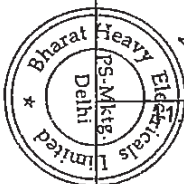

mandatory

⑦

APPENDIX B
PAGE 19 OF 31

SUB-VENDOR LIST FOR C&I ITEMS

SI No	Package Code	Package Name	Supplier Name	Supplier Communication Address	Supplier Works Address	Tech Limit	Fin Limit
1	145-04000-A	CONTROL VALVE	SAMSON CONTROLS PVT. LTD.	Mr. Atul raje-MD D 281, MIDC Ranjangaon Ta Shirur Pune Phone- 02067246600 Pincode : 412220 Email : sales@samsoncontrols.net	Works-1-> Others D 281, MIDC Ranjangaon -Pune- MAHARASHTRA India Phone- 02067246600,8554997963 FAX : Pincode : 412220 Email : sales@samsoncontrols.net		
2	145-04000-A	CONTROL VALVE	FORBES MARSHALL ARCA PVT.LTD.	A-34/35 , MIDC ESTATE, H-BLOCK, PIMPRI, PUNE, Phone- 020-27442020, Pincode : 411018 Email : mnadgaundi@forbesmarshall.com	Works-1->Mr. Sanjeev Shinde A-34/35 MIDC Estate,H Block, Pimpri, -Pune-MAHARASHTRA India Phone- 9323176406 FAX : 020-27442040 Pincode : 411018 Email : sshinde@forbesmarshall.com	No technical limit exists except for feed control valve. For feed control valves, approved up to sub-critical power plants of 600 MW rating	
3	145-04000-A	CONTROL VALVE	INSTRUMENTATION LTD.	KANJIKODE WEST, PALALKKAD, PALAKKAD Phone- 2566127-130,2567128 Pincode : 678623 Email : icvldil@gmail.com:fa2@ilngt.com	Works-1->D.SASIDHARAN, AGM(Works&PPC) KANJIKODE WEST, -PALAKKAD-KERALA INDIA Phone- 0491-2566536 FAX : 0491-2566135 Pincode : 678623 Email : sasidharan@ilngt.com		
4	145-04000-A	CONTROL VALVE	Koso India Private Limited,	H 33 & 34, MIDC, Ambad, Nashik, Phone- 09650233433 Pincode : 422010, Email : jetmal.gour@koso.co.in	Works-1->P.J.ASHOK KUMAR/SEEMA ANAND Control Valve Division, H-33&34, MIDC, Ambad, -Nashik-MAHARASHTRA India Phone- 91 944 744 3198 FAX : 0491 - 5269914 Pincode : 422010 Email : pja@koso.co.in Works-2->+P.J.ASHOK KUMAR/SEEMA ANAND J-1,MIDC,Ambad - Nashik-MAHARASHTRA India Phone- 91 944 744 3198 FAX : 0491 - 5269914 Pincode : 422010 Email : pja@koso.co.in		
5	145-04000-A	CONTROL VALVE	KSB MIL CONTROLS LTD.	Mr.Jacob Cherian/Mr.Geo Jolly Meladoor, Annamanada P.O. MALA, Thrissur Phone- 0480-2695700 Pincode : 680741 Email : hiiu.simon@ksb.com	Works-1->Mr.Biju Simon/Mr.Jose Paul Meladoor, Annamanada, -Thrissur-KERALA INDIA Phone- 9447555500 FAX : 91 480 2890952 Pincode : 680741 Email : jose.paul@ksb.com		
6	145-04000-A	CONTROL VALVE	SUZHOU DELAN ENERGY SCIENCE & TECHNOLOGY CO., LTD.	No 566 Fangqiao Road Caohu Industrial Park, Xiangcheng Economic Development Zone, Suzhou Phone- 008618012776062 Pincode : 215143 Email : jeanielei@delan-valve.com	Works-1->Mr. Zong Xin CEO No 566 Fangqiao Road Caohu Industrial Park,Xiangcheng E. Z. -Suzhou-Foreign Country CHINA Phone- 008618012776062 FAX : Pincode : 215143 Email : jeanielei@delan-valve.com		
7	145-04000-A	CONTROL VALVE	R.K.CONTROL INSTRUMENTS PVT. LTD.	PLOT NO.A-250, OPP.POLICE STATION, WAGLE INDUSTRIAL ESTATE, THANE Phone- 25820943/2331 Pincode : 400604 Email : rkcipl@vsnl.com ; rkcinvt@bol.net.in	Works-1->SAVITH KUMAR PLOT NO. A-250, OPP.POLICE STATION,WAGLE INDUSTRIAL ESTATE, THANE -THANE- MAHARASHTRA INDIA Phone- 022-'66060942 FAX : 022-25820801 Pincode : 400 604 Email : rkadmin@rkcipl.co.in	For subcritical power plant up to 150MW	
8	145-04000-A	CONTROL VALVE	Mascot Valves Pvt. Ltd.	166-167 GIDC Naroda Ahmedabad Phone- 0792282 1619 Pincode : 382330 Email : dom.sales@mascotvalves.com	Works-1->Varun Patel Dir 166-167 ,GIDC Naroda - Ahmedabad-GUJARAT India Phone- 0792282 1619 / 3369 FAX : Pincode : 382330 Email : dom.sales@mascotvalves.com		
9	145-04000-A	CONTROL VALVE	Valvitalia S.P.A. ,	Mr. Salvatore Ruggeri Via Tortona 69, Rivanazzano (Pavia) Phone- +39-03839459875 Pincode : 27055 Email : dario.toruluccio@valvitalia.com	Works-1->Mr. Salvatore Ruggeri Via Tortona 69,Rivanazzano (Pavia) -- Italy Phone- +39-03839459875 FAX : Pincode : 27055 Email : dario.toruluccio@valvitalia.com; diego.noletti@valvitalia.com: sales@bhoassociates.com		

SUB-VENDOR LIST FOR C&I ITEMS

SI No	Package Code	Package Name	Supplier Name	Supplier Communication Address	Supplier Works Address	Tech Limit	Fin Limit
10	145-04000-A	CONTROL VALVE	BOMAFA SPECIAL VALVE SOLUTIONS PVT LTD	Mr. K.M. Anklesaria/ R. M. Anklesaria Plot No: 285/2, Panchratna Estate, Near Ramol Bridge, Vatva Ahmedabad Phone- 079-40083825 Pincode : 382445 Email : info@bomafa- india.com	Works-1->Mr. K.M. Anklesaria/ Mr. R.M. Anklesaria Dir Plot No: 285/2, Panchratna Estate, Near Ramol Bridge, Vatva, - Ahmedabad-GUJARAT INDIA Phone- 079-40083825 FAX : Pincode : 382445 Email : info@bomafa-india.com		
11	145-04000-A	CONTROL VALVE	DRESSER VALVE INDIA PVT. LTD	Mr. Raj Raman/Mr. Rajkumar Moria S.F. No: 608,Chettipalayam Road, Echanari Post, Coimbatore Phone- +91-98451 19085 Pincode : 641021 Email : Anoop.Ramachandran@ge.com	Works-1->Mr. Anoop Ramchandran S.F. No: 608,Chettipalayam Road, Echanari Post, -Coimbatore-TAMIL NADU INDIA Phone- +919500978296 FAX : +91 4223011200 Pincode : 641021 Email : Anoop.Ramachandran@ge.com		
12	145-04000-A	CONTROL VALVE	Severn Glocon India Pvt. Ltd.	F96 & F97, Sipcot Industrial Park, Irungattukottai, Chennai, Phone- 044-47104200, Pincode : 602117, Email : info@severnlocon.co.in.	Works-1->Mr. K.Kaushik, F96 & F97, Sipcot Industrial Park,Irungattukottai, -Chennai-TAMIL NADU India Phone- 044-47104200, FAX : 044-47100073, Pincode : 602117, Email : info@severnlocon.co.in		
13	145-04000-A	CONTROL VALVE	EMERSON PROCESS MANAGEMENT CHENNAI LIMITED	147, KARAPAKKAM VILLAGE, CHENNAI Phone- 23722184, 23716242 Pincode : 600096 Email : jatinder.singh@emerson.com	Works-1->Mr. Rangarajan (Head - Lean and Manufact 147,Karapakkam Village, -Chennai-TAMIL NADU India Phone- 0444903 4395 FAX : Pincode : 600097 Email : Rangaraian.M@emerson.com		
14	145-04000-A	CONTROL VALVE	WALDEMAR PRUSS ARMATURENFABRIK GMBH	Mr. Winfried Dremhel Schulenburglandstrasse 261, Hannover Phone- +49-511279260 Pincode : 30419 Email : dremhel@pruss.de; vogel@pruss.de	Works-1->Mr. Winfried Dremhel CEO Schulenburglandstrasse 261, -Hannover- GERMANY Phone- +49-511279260 FAX : Pincode : 30419 Email : dremhel@pruss.de		
15	145-06000-A	PRESSURE SWITCH/DIFF. PRESSURE SWITCH	SWITZER PROCESS INSTRUMENTS PVT. LTD.	Mr. V S Jayaprakash, 128, SIDCO North Phase, Ambattur Estates CHENNAI Phone- 044-26252017/2018 Pincode : 600050 Email : sales@switzernprocess.co.in	Works-1->C S Shankar 127, Sidco North Phase, Ambattur Estates, -CHENNAI-TAMIL NADU INDIA Phone- 8754491904 FAX : 044-26248849 Pincode : 600050 Email : cservice@switzerinstrument.com		
16	145-06000-A	PRESSURE SWITCH/DIFF. PRESSURE SWITCH	DRESSER INDUSTRIES INC.	Mr. Nishit Patel/Mr. Anuj Verma Plot No.2306, Phase II, GIDC Chhatral Kalol Phone- 02764-233682 Pincode : 382729 Email : Nishit.patel@ashcroftindia.com			
17	145-06000-A	PRESSURE SWITCH/DIFF. PRESSURE SWITCH	Barksdale GmbH, Germany	Michael Weileder Dorn Assenheimer, Strasse 27 Reichelsheim Phone- +91- 9999107840 Pincode : D-61203 Email : msingh@barksdale.de			
18	145-06000-A	PRESSURE SWITCH/DIFF. PRESSURE SWITCH	GENERAL INSTRUMENTS CONSORTIUM	Mr. Amarendra Kulkarni 194/195, Gopi Tank Road, Off. Pandurang Naik Marg, Mahim Mumbai Phone- 9323195251 Pincode : 400016 Email : amarendra@general-gauges.com			
19	145-06000-A	PRESSURE SWITCH/DIFF. PRESSURE SWITCH	PRECISION MASS PRODUCTS PVT. LTD.	Mr. Nishit Patel/Mr. Anuj Verma Plot No.2306, Phase II, GIDC Chhatral Kalol Phone- 9999464663 Pincode : 382729 Email : sales@precisionmass.com	Works-1->Mr. Hitesh Parmar/Mr. Hitesh Parmar Plot No.2306, Phase II, GIDC Chhatral, -Kalol-GUJARAT INDIA Phone- 9327359227 FAX : 02764-233440 Pincode : 382729 Email : hitesh.parmar@ashcroftindia.com		

SUB-VENDOR LIST FOR C&I ITEMS

SI No	Package Code	Package Name	Supplier Name	Supplier Communication Address	Supplier Works Address	Tech Limit	Fin Limit
20	145-06000-A	PRESSURE SWITCH/DIFF. PRESSURE SWITCH	INDFOS INDUSTRIES LIMITED	B-20-21, INDUSTRIAL AREA, MEERUT ROAD, GHAZIABAD Phone- 0120-2712016 Pincode : Email : mkt@indfos.com			
21	145-06000-A	PRESSURE SWITCH/DIFF. PRESSURE SWITCH	INDFOS (INDIA) LIMITED	MR.L.C.VENKATRANGAN/MR.B.KANNAN New No.17, II Floor, Adwave Towers, Dr.Sevalia Shivaji Salai, T.Nagar Chennai Phone- +91 44 24353407 Pincode : 600017 Email : delhi@indfos.com			
22	145-06000-A	PRESSURE SWITCH/DIFF. PRESSURE SWITCH	SOR INC.	LARRY DEGARMO/Avdhesh Chandra, 14685 W. 105TH STREET LENEXA Phone- 09810905139, Pincode : 66215 Email : Ldegarmo@sorinc.com, avdhesh@sherman-india.com	Works-1->LARRY DEGARMO/ ROY STUMBOUGH 14685 W. 105TH STREET, LENEXA -KANSAS- USA Phone- 913-888-0767 FAX : 913-888-0767 Pincode : 66215 Email : rstumbough@sorinc.com		
23	145-06000-A	PRESSURE SWITCH/DIFF. PRESSURE SWITCH	Kaustubha Udyog,	S.No. 36/1/1, Sinhgad Road, Vadgaon Khurd, Near Lokmat Press, Pune, Phone- 020-24393577, Pincode : Email : pressure@vsnl.com,			
24	145-08000-A	PRESSURE GAUGE/ DIFF.PRESSURE GAUGE	H.GURU INDUSTRIES	Mr. G. D. Hazra/Mr. P. K. Mitra 10 B, HO-CHI-MINH SARANI, KOLKATA Phone- 033 2282 2463 / 1637 Pincode : 700071 Email : mguru@vsnl.net	Works-1->NA NA -- Phone- FAX : Pincode : Email :		OVERALL PENDING ORDER VALUE (EXCLUDING VALUE OF ORDERS ALREADY EXECUTED) FOR ALL PACKAGES FOR WHICH VENDOR IS REGISTERED SHALL NOT EXCEED RS. 1.0 CRORE
25	145-08000-A	PRESSURE GAUGE/ DIFF.PRESSURE GAUGE	A.N. INSTRUMENTS PVT. LTD.	MARKETING DIVISION, 5th FLOOR, 59-B, CHOWRINGHEE ROAD, KOLKATA Phone- 24757784,22472509 Pincode : 700020 Email : anidel@bol.net.in	Works-1->Mr. Gautam Mukherjee Kusumba,Sonarapur Station Road,P.O. -Narendrapur, -Kolkata-WEST BENGAL INDIA Phone- 9836878855 FAX : 033-24342748 Pincode : 700103 Email : gkm_ani@hotmail.com		
26	145-08000-A	PRESSURE GAUGE/ DIFF.PRESSURE GAUGE	BOSE PANDA INSTRUMENTS PVT.LTD.	Mr. Partha Bose 44, Saheed Hemanta Kumar Bose, Sarani, Kolkata Phone- +91 33 2548 7220 Pincode : 700074 Email : parthabosebpi@gmail.com; bosepanda@vsnl.net	Works-1->Mr. Partha Bose 44, Saheed Hemanta Kumar Bose,Sarani, -Kolkata-WEST BENGAL India Phone- +91 33 2548 7220 FAX : +91 33 2548 0429, Pincode : 700074 Email : parthabosebpi@gmail.com bosepanda@vsnl.net		

SUB-VENDOR LIST FOR C&I ITEMS

SI No	Package Code	Package Name	Supplier Name	Supplier Communication Address	Supplier Works Address	Tech Limit	Fin Limit
27	145-08000-A	PRESSURE GAUGE/ DIFF.PRESSURE GAUGE	PRECISION MASS PRODUCTS PVT. LTD.	Mr. Nishit Patel/Mr. Anuj Verma Plot No.2306, Phase II, GIDC Chhatral Kalol Phone- 9999464663 Pincode : 382729 Email : sales@nprecisionmass.com	Works-1->Mr. Hitesh Parmar/Mr. Hitesh Parmar Plot No.2306, Phase II, GIDC Chhatral, -Kalol-GUJARAT INDIA Phone- 9327359227 FAX : 02764-233440 Pincode : 382729 Email : hitesh.parmar@ashcroftindia.com		
28	145-08000-A	PRESSURE GAUGE/ DIFF.PRESSURE GAUGE	H.GURU INSTRUMENTS (SOUTH INDIA) P. LTD	32,INDUSTRIAL SUBURB YESWANTHAPUR BANGALORE Phone- 080-23370300, Pincode : 560022 Email : info@hgurusouth.com	Works-1->Shikha Hazra/ Shyamal Hazra 32, Industrial Suburb,Yeshwanthpur -BANGALORE-KARNATAKA INDIA Phone- 080-23370300 FAX : 080-23379890 Pincode : 560022 Email : shikhahazra@hgurusouth.com		
29	145-08000-A	PRESSURE GAUGE/ DIFF.PRESSURE GAUGE	Baumer Technologies India Pvt. Ltd.	Mr. Shyam Warilani/Mr. V Suresh Babu 36, DAMJI SHAMJI INDUSTRIAL COMPLEX, OFF.-MAHAKALI CAVES ROAD, ANDHERI(E) MUMBAI Phone- +91 99589 25151 Pincode : 400093 Email : sales.in@baumer.com	Works-1->Mr. Shyam Warilani/Mr. V Suresh Babu Plot No 34 À GIDC À Phase 1, -VAPI-GUJARAT INDIA Phone- +91 11 4161 7111 FAX : 022 2687 3613 Pincode : 396 195 Email : pbajaj@baumer.com		
30	145-08000-A	PRESSURE GAUGE/ DIFF.PRESSURE GAUGE	FORBES MARSHALL (HYD) LTD.	MR SAILESH PATALAY/MR. M K SRINIVASAN PLOT NO.A-19/2, & T- 4/2, IDA, NACHARAM, HYDERABAD Phone- 9849913704 Pincode : 500 076 Email : mksrinivasan@forbesmarshall.com	Works-1->MR G.SRINIVASAN/MR ANUJ MALPANI PLOT NO:A-19/2 & T-4/2,I.DA. NACHARAM , -HYDERABAD- TELANGANA INDIA Phone- 09866550762 FAX : 040 27152193 Pincode : 560076 Email : gshrinivasan@forbesmarshall.com		
31	145-08000-A	PRESSURE GAUGE/ DIFF.PRESSURE GAUGE	GAUGE BOURDON INDIA PVT. LTD.	194/195, Gopi Tank Road, Off Pandurang Naik Marg, Mahim Mumbai, Phone- 011-41607463, Pincode : 400016, Email : aicdelhi@general-gauges.com	Works-1->Gauge Bourdon India Pvt. Ltd., Plot No-4, 5, 6,Jawahar Co-operative Industrial Estate, -Kalamboli Taluka Panvel-MAHARASHTRA India Phone- 022-27421095, FAX : 022-27421901, Pincode : 410209, Email : info@general- gauges.com		
32	145-08000-A	PRESSURE GAUGE/ DIFF.PRESSURE GAUGE	Nesstech Instruments Private Limited	26/2, G Type, Global Industrial Park Near Nahuli Railway Crossing, Valvada Vapi Phone- 9920576002 Pincode : 396105 Email : sales@nesstech.co.in	Works-1-> Others 26/2, G Type, Global Ind. Park Near Nahuli Railway Crossing, -Vapi-GUJARAT INDIA Phone- 9920576002 FAX : Pincode : 396105 Email : sales@nesstech.co.in, bkapadia@nesstech.co.in		
33	145-08000-A	PRESSURE GAUGE/ DIFF.PRESSURE GAUGE	SCIENTIFIC DEVICES (BOMBAY) PVT LTD,	Office no. 53, Shree Manoshi Complex, Plot No. 5 & 6, Sec-3, Ghansoli (East), Navi Mumbai, Phone- 9892230623, Pincode : 400 701, Email : sdbnl@vsnl.com	Works-1->Scientific Center, Others By-Pass Junction,Near Kalsekar College kausa, mumbra,Thane -Mumbai- MAHARASHTRA INDIA Phone- 022-25491409,9892230623 FAX : Pincode : 400612 Email : sdbpl@vsnl.com		
34	145-14000-A	TRANSMITTERS	YOKOGAWA INDIA LIMITED,	PLOT NO.96, ELECTRONICS CITY COMPLEX, HOSUR ROAD, BANGALORE, Phone- 080-41586000, Pincode : Email : udav.shankar@in.yokogawa.com	Works-1-> PLOT NO.96, ELECTRONICS CITY COMPLEX, HOSUR ROAD, -BANGALORE-KARNATAKA INDIA Phone- 080- 41586000, FAX : 080-28521442, Pincode : Email : udav.shankar@in.yokogawa.com		
35	145-14000-A	TRANSMITTERS	ABB INDIA LIMITED	MR. RAJIV GOVIL 14, MATHURA ROAD, FARIDABAD Phone- 09971085678 Pincode : 121003 Email : vipin.swami@in.abb.com		PRESSURE TRANSMITTER, DP TRANSMITTER and TEMP TRANSMITTER	

SUB-VENDOR LIST FOR C&I ITEMS

SI No	Package Code	Package Name	Supplier Name	Supplier Communication Address	Supplier Works Address	Tech Limit	Fin Limit
36	145-14000-A	TRANSMITTERS	V. AUTOMAT & INSTRUMENTS (P) LTD.	Mr. R. K. BASSI/Mr. PRAVEEN KUMAR F-61, OKHLA INDL.AREA, PH-1 NEW DELHI Phone- 9810005826 Pincode : 110 020 Email : sales@vautomat.com	Works-1->Mr. BHAGWAN SINGH/ Mr. NANDAN SINGH F-61, OKHLA INDL.AREA,PHASE-I -NEW DELHI-DELHI INDIA Phone- 011-47627200 Extn. 3 FAX : 011- 26819440 Pincode : 110 020 Email : production@vautomat.com	a)DISPLACEMENT TYPE TRANSMITTERS. b)PRESSURE AND DP TRANSMITTERS	
37	145-14000-A	TRANSMITTERS	Pune Techtrol Pvt. Ltd.	N.P.Khatan/Sudhakar Badiger S-18, MIDC Bhosari, Pune Phone- 9850560042 Pincode : 411 026 Email : ho@punetechtrol.com		Only for capacitance Type Level Transmitter	
38	145-14000-A	TRANSMITTERS	TOSHNIWAL INDUSTRIES PVT. LTD.,	Industrial Estate, Makhupura, Ajmer, Phone- 9352009000, Pincode : 305002, Email : info@tipl.com,	Works-1-> Khasra No.: 218-230& 235, Industrial Estate,Makhupura, -Ajmer-RAJASTHAN India Phone- 9887865856, FAX : 0145-2695174, Pincode : 305002, Email : raieev.quota@tipl.com		
39	145-14000-A	TRANSMITTERS	SBEM PVT. LTD.	MR.N.K. BEDARKAR/MR. VISHWANATH KARANDIK 39, ELECTRONIC CO.OP. ESTATE, PUNE SATARA ROAD PUNE, Phone- 912041030100 Pincode : 411009 Email : newdelhi@sbem.co.in	Works-1->MR. MOHAN PADWAL 691/A/2,BIBWEWADI INDL ESTATE -PUNE-MAHARASHTRA INDIA Phone- 918600042374 FAX : 912024215670 Pincode : 411037 Email : wm@sbem.co.in	FOR CAPACITANCE TYPE.	
40	145-14000-A	TRANSMITTERS	Endress + Hauser (India) Pvt. Ltd.,	Mr. Prakash Vaghela 215-216, DLF Tower 'A', Jasola District Centre, New Delhi, Phone- 9717593001, Pincode : 110025, Email : prakash.vaghela@in.endress.com	Works-1-> M-171 to 173, MIDC, Waluj, -Aurangabad-MAHARASHTRA India Phone- 9881000474, FAX : 0240-2555179, Pincode : 431136, Email : Narendra.Kulkarni@wetzler.endress.com	"Except Displacement Type Level Transmitters"	
41	145-14000-A	TRANSMITTERS	Moore Industries International Inc.	Leonard.W. Moore/ Matt Moren 16650 Schoenborn St. North Hills Phone- +1 818 830 5548 Pincode : 91343 Email : mmoren@miinet.com	Works-1->Matt Moren/Gina Cruz 16650 Schoenborn St., North Hills -CALIFORNIA- USA Phone- +1 818 894 7111, ext FAX : +1 818 830 5588 Pincode : 91343 Email : gcruz@miinet.com		
42	145-14000-A	TRANSMITTERS	PANAM ENGINEERS	Mr. Santosh Shukla 203, Jaisingh Business,Parsiwada, Sahar road,Andheri(East), Mumbai, Phone- 9892179529, Pincode : 400099, Email : santosh@panamengineers.com	Works-1->Mr. Santosh Shukla Others R-628,TTC Industrial Area, MIDC Rabale, -Navi Mumbai-MAHARASHTRA India Phone- 9821350761, FAX : 022-27695559, Pincode : 400701, Email : sales@panamengineers.com	For Pressure and Diff. Pressure transmitter	
43	145-14000-A	TRANSMITTERS	Honeywell Automation India Limited	Mr. Ritwij Kulkarni 917, INTERNATIONAL TRADE TOWER, NEHRU PLACE, NEW DELHI Phone- 9890200584 Pincode : 110019 Email : rajesh.chaudhary@honeywell.com	Works-1->Mr.Kedar Tillu 53, 54, 56 & 57,Hadapsar Industrial Estate -PUNE-MAHARASHTRA INDIA Phone- 9665034625 FAX : 020 66039905 Pincode : 411013 Email : kedar.tillu@honeywell.com		
44	145-14000-A	TRANSMITTERS	EMERSON PROCESS MANAGEMENT (INDIA) PVT.LTD.	Mr. Amit Paithankar/Vikram Raj Singh 206-210,BALARAMA BUILDING 2ND FLR. BANDRA EAST MUMBAI Phone- 9619121500 Pincode : 400051 Email : vikramraj.singh@emerson.com	Works-1->Kalpesh Chandan/Hrishikesh Aghor Plot No. A 145/4 TTC IND AREA,MIDC, PAWANE, -NAVI MUMBAI-MAHARASHTRA INDIA Phone- 9619688001 FAX : 022-66736000 Pincode : 400 705 Email : Kalpesh.chandan@emerson.com		

SUB-VENDOR LIST FOR C&I ITEMS

SI No	Package Code	Package Name	Supplier Name	Supplier Communication Address	Supplier Works Address	Tech Limit	Fin Limit
45	145-14000-A	TRANSMITTERS	SMART INSTRUMENTS LTD, BRAZIL	Agents: Digital Electronic Ltd. 74/11 'C' Cross Road MIDC Andheri (East) MUMBAI Phone- 28208477 Pincode : 400093 Email : corp@delbby.rpgms.ems.vsnl.net.in		LD-301 & T-301 TRANSMITTER FROM M/S SMART EQUIPMENTS BRAZIL.	
46	145-14000-A	TRANSMITTERS	SIEMENS LIMITED	Dr. Armin Bruck/Sandeep Mathur 130, Pandurang Budhkar Marg Worli Mumbai Phone- 0124 383 7377 Pincode : 400018 Email : ankit.varshnev@siemens.com	Works-1->Ankit Varshney Kalwa Works, Thane-Belapur Road, Thane, -MUMBAI-MAHARASHTRA INDIA Phone- FAX : Pincode : 400708 Email :		
47	145-14000-A	TRANSMITTERS	NIVO CONTROLS PVT. LTD.	Mr. Praveen Toshniwal 104-115, Electronic Complex, Indore Phone- 0731-4081305 Pincode : 452010 Email : sales@nivocontrols.com	Works-1->Mr. Praveen Toshniwal 104-115, Electronic Complex, -Indore-MADHYA PRADESH India Phone- 0731-4081305 FAX : 0731-255075 Pincode : 452010 Email : sales@nivocontrols.com	For Capacitance type only	
48	145-21000-A	DIFFERENTIAL PRESSURE SWITCH	SOR INC.	LARRY DEGARMO/Avdhesh Chandra, 14685 W. 105TH STREET LENEXA Phone- 09810905139, Pincode : 66215 Email : Ldegarmo@sorinc.com, avdhesh@sherman-india.com			
49	145-25000-A	JUNCTION BOX	K.S.INSTRUMENTS PVT.LTD.	S Raghavan No. 72, 3rd Main, 1st Stage Industrial Suburb, Yeshwanthpur Bangalore Phone- 9880385770 Pincode : 560022 Email : sales1@ksinstruments.net			
50	145-25000-A	JUNCTION BOX	SUCHITRA INDUSTRIES	NO-2,OPP-27 AECS LAYOUT 2ND STG REJAMAHALVILAS EXTN 2ND STG BANGALORE Phone- Pincode : Email : suchitra_industriesblr@gmail.com	Works-1->B. Srinivas Suchitra Industries, Opp No 53, Muneshwara Black Devinagar, Lottagal hal -BANGALORE-KARNATAKA INDIA Phone- 080-23511247 FAX : Pincode : 560094 Email : suchitra_industries@yahoo.com		
51	145-25000-A	JUNCTION BOX	Shrenik & Company,	Mr. Mitesh Shah/Mr. Pulin Shah 39 A/3 ,Panchratna Industrial Estate, Sarkhej-Bavla Road Ahmedabad Phone- 9825024921 Pincode : 382213 Email : sales@pustron.com, pulin@sumip.com	Works-1->Mr.Pulin Shah/ Mr. Kaloesh Parmar 39 A/3 ,Panchratna Industrial Est,Sarkhej-Bavla Road, Changodhar - Ahmedabad-GUJARAT INDIA Phone- 98250 80339 1 FAX : 079-26932424 Pincode : 382213 Email : sales@sumip.com		
52	145-25000-A	JUNCTION BOX	FLEXPRO ELECTRICALS PVT. LTD.	Mr. Dineshbhai Zaveri C-1/ 27&37, GIDC, Kabilpore, Navsari Phone- 02637-265140,265003 Pincode : 396424 Email : flexpro@flexproltd.com	Works-1->Mr. Dineshbhai Zaveri CEO C-1/ 27&37, GIDC, Kabilpore, -Navsari-GUJARAT INDIA Phone- 02637-265140,265003 FAX : 02637-265308 Pincode : 396424 Email : flexpro@flexproltd.com	Metal type junction box only	
53	145-25000-A	JUNCTION BOX	AJMERA INDUSTRIAL & ENGINEERING WORKS	JIGNESH MAHENDRA AJMERA DENA BANK BLDG.,SHREE NAGESH INDL. ESTATE,STATION ROAD, MUMBAI Phone- 022 67973578 Pincode : 400 088 Email : ajmera@ajmera.net, jmajmera@yahoo.com	Works-1->JIGNESH MAHENDRA AJMERA DENA BANK BLDG., SHREE NAGESHINDL. ESTATE,STATION ROAD, - MUMBAI-MAHARASHTRA INDIA Phone- 022 67973578 FAX : Pincode : 400 088 Email : ajmera@ajmera.net		

SUB-VENDOR LIST FOR C&I ITEMS

SI No	Package Code	Package Name	Supplier Name	Supplier Communication Address	Supplier Works Address	Tech Limit	Fin Limit
54	145-32000-A	INSTRUMENTS TUBE FITTINGS	VIKAS INDUSTRIAL PRODUCTS	S.R.SINGH/NAVEEN SINGH B - 2, SECTOR - 6, NOIDA Phone- +91-9810122070 Pincode : 201301 Email : naveensingh@vsnl.com	Works-1->S.R.SINGH/ NAVEEN SINGH B - 2, SECTOR - 6, - NOIDA-UTTAR PRADESH INDIA Phone- 0120-4352940 FAX : 0120-4352940 Pincode : 201301 Email : naveensingh@vsnl.com		Over all financial limit for ordering as Rs.30 lacs (Rs.Thirty Lacs). The registration category & the financial limit may be reviewed after survey in March 2009 and approval thereof. Registered w.e.f. 22.01.2009.
55	145-32000-A	INSTRUMENTS TUBE FITTINGS	Fluid Controls Pvt. Ltd.	Sophie Y. Moochhala/Mayur Rajput J.V.PATEL, I.T.I CMPD, B.MADHUKAR MARG, ELPHINSTONE ROADSTN.(WR), MUMBAI Phone-(022) 43338000 Pincode : 400013 Email : sales@fluidcontrols.com	Works-1->Mr. Tansen Choudhari/Mr. Mahesh Darekar Shed No.8, Lonavla Indl.Co-op.Estate Ltd,Nagargaon, - Lonavla-MAHARASHTRA INDIA Phone- 9823951347 FAX : (02114) 271132 Pincode : 410 401 Email : factory@hyd-air.com		
56	145-32000-A	INSTRUMENTS TUBE FITTINGS	PRECISION ENGINEERING INDUSTRIES	K. SITARAM/ K. SRINIVAS 7,SIDHAPURA INDUSTRIAL ESTATE S.V. ROAD,GOREGAON(W) MUMBAI Phone- 022 42631700 Pincode : 400 062 Email : neiks@vsnl.com	Works-1->ALEX BAPTIST/ K. SRINIVAS 7. SIDHAPURA INDUSTRIAL ESTATE,SV ROAD, GOREGAON(WEST) - MUMBAI-MAHARASHTRA INDIA Phone- 022-42631700 FAX : 022-40035259 Pincode : 400 062 Email : srinivas@precision-engg.com		
57	145-32000-A	INSTRUMENTS TUBE FITTINGS	AURA INCORPORATED	NIRAJ SHARAN/SUJIT KUMAR W-167A, GREATER KAILASH-II NEW DELHI Phone- 9810182430 Pincode : 110048 Email : niraj@aurainc.com			
58	145-38000-A	INSTRUMENTS PIPE FITTINGS	VIKAS INDUSTRIAL PRODUCTS	S.R.SINGH/NAVEEN SINGH B - 2, SECTOR - 6, NOIDA Phone- +91-9810122070 Pincode : 201301 Email : naveensingh@vsnl.com	Works-1->S.R.SINGH/ NAVEEN SINGH B - 2, SECTOR - 6, - NOIDA-UTTAR PRADESH INDIA Phone- 0120-4352940 FAX : 0120-4352940 Pincode : 201301 Email : naveensingh@vsnl.com		Over all financial limit for ordering as Rs.30 lacs (Rs.Thirty Lacs).
59	145-38000-A	INSTRUMENTS PIPE FITTINGS	Fluid Controls Pvt. Ltd.	Sophie Y. Moochhala/Mayur Rajput J.V.PATEL, I.T.I CMPD, B.MADHUKAR MARG, ELPHINSTONE ROADSTN.(WR), MUMBAI Phone-(022) 43338000 Pincode : 400013 Email : sales@fluidcontrols.com	Works-1->Mr. Tansen Choudhari/Mr. Mahesh Darekar Shed No.8, Lonavla Indl.Co-op.Estate Ltd,Nagargaon, - Lonavla-MAHARASHTRA INDIA Phone- 9823951347 FAX : (02114) 271132 Pincode : 410 401 Email : factory@hyd-air.com		
60	145-38000-A	INSTRUMENTS PIPE FITTINGS	AURA INCORPORATED	NIRAJ SHARAN/SUJIT KUMAR W-167A, GREATER KAILASH-II NEW DELHI Phone- 9810182430 Pincode : 110048 Email : niraj@aurainc.com			
61	145-38000-A	INSTRUMENTS PIPE FITTINGS	PRECISION ENGINEERING INDUSTRIES	K. SITARAM/ K. SRINIVAS 7,SIDHAPURA INDUSTRIAL ESTATE S.V. ROAD,GOREGAON(W) MUMBAI Phone- 022 42631700 Pincode : 400 062 Email : neiks@vsnl.com	Works-1->ALEX BAPTIST/ K. SRINIVAS 7. SIDHAPURA INDUSTRIAL ESTATE,SV ROAD, GOREGAON(WEST) - MUMBAI-MAHARASHTRA INDIA Phone- 022-42631700 FAX : 022-40035259 Pincode : 400 062 Email : srinivas@precision-engg.com		
62	145-45000-A	INSTRUMENT FITTINGS	HP VALVES & FITTINGS INDIA PVT. LTD.	S. Harichandran/P.S. Pandi B-11, Mugappair Industrial Estate, CHENNAI Phone- 044 26252537 Pincode : 600037 Email : sales@hpvalvesindia.com	Works-1->S. Harichandran/ P.S. Pandi B-11, Mugappair Industrial Estate, -CHENNAI-TAMIL NADU INDIA Phone- 044-25252537 FAX : 044-26252538 Pincode : 600037 Email : sales@hpvalvesindia.com		

SUB-VENDOR LIST FOR C&I ITEMS

SI No	Package Code	Package Name	Supplier Name	Supplier Communication Address	Supplier Works Address	Tech Limit	Fin Limit
63	145-45000-A	INSTRUMENT FITTINGS	Perfect Instrumentation Control (India) Pvt. Ltd.	MD Hussain Shaikh/Shahanawaz Khan Gala No. 168, Loheki Chwal,216/ 218, Maulana Azad Rd. Nagpada Junction Mumbai Phone- 91-9324383121 Pincode : 400008 Email : shahanawaz.khan@perfectinstrumentation.com	Works-1->Shahanawaz Khan Vishweshwar Ind. Premises Co-op Soc. Ltd,F-18/19, Pradhikaran,Bhosadi MIDC -PUNE- MAHARASHTRA INDIA Phone- 020-30694134 FAX : 022- 23013010 Pincode : 411026 Email : shahanawaz.khan@perfectinstrumentation.com		
64	145-45000-A	INSTRUMENT FITTINGS	Arya Crafts & Engineering Pvt. Ltd.	Mr.Sanjay Brahman/Mr.Shyam Vazirani 102, Vora Industrial Estate No.4 Navghar, Vasai Road (E) Dist.Thane, Mumbai Phone- +91-250-2392246 Pincode : 401210 Email : arya@aryaengg.com			
65	145-45000-A	INSTRUMENT FITTINGS	PRECISION ENGINEERING INDUSTRIES	K. SITARAM/ K. SRINIVAS 7,SIDHAPURA INDUSTRIAL ESTATE S.V. ROAD,GOREGAON(W) MUMBAI Phone- 022 42631700 Pincode : 400 062 Email : peiks@vsnl.com	Works-1->ALEX BAPTIST/ K. SRINIVAS 7. SIDHAPURA INDUSTRIAL ESTATE,SV ROAD, GOREGAON(WEST) - MUMBAI-MAHARASHTRA INDIA Phone- 022-42631700 FAX : 022-40035259 Pincode : 400 062 Email : srinivas@precision-engg.com		
66	145-45000-A	INSTRUMENT FITTINGS	AURA INCORPORATED	NIRAJ SHARAN/SUJIT KUMAR W- 167A, GREATER KAILASH-II NEW DELHI Phone- 9810182430 Pincode : 110048 Email : niraj@aurainc.com			
67	145-45000-A	INSTRUMENT FITTINGS	Comfit & Valve Pvt. Ltd.	Mr. Jeetu Jain/Mr. Vinay Sosa Survey No. 23/1, Part 2, Ahmedabad- Mehsana Highway Laxmipura, Nandasan Phone- 02764-267036/37 Pincode : 382705 Email : marketing@com-fit.com	Works-1->Miss Sonal Pithadia/Miss Pavan Chavda Survey No. 23/1, Part 2, Ahmedabad-Mehsana Highway, Laxmipura - Nandasan-GUJARAT INDIA Phone- 8460848087 FAX : 2764- 267036/37 Pincode : 382705 Email : domestic@com- fit.com		
68	145-45000-A	INSTRUMENT FITTINGS	FLUIDFIT ENGINEERS PVT. LTD.	Mr. Abbas Bhola Potia Building No. 2, Office No. 3,292, Bellasis Road,Mumbai Central (East) Mumbai Phone- 9920044113 Pincode : 400008 Email : ab@fluidfitengg.com	Works-1->Mr. Abbas Bhola Unit No. 16, Supreme Industrial Estate,Kaman Bhiwandi Road,Devdal, -Vasai East- MAHARASHTRA India Phone- 9920044113 FAX : 07303178243 Pincode : 401208 Email : ab@fluidfitengg.com		
69	145-45000-A	INSTRUMENT FITTINGS	VIKAS INDUSTRIAL PRODUCTS	S.R.SINGH/NAVEEN SINGH B - 2, SECTOR - 6, NOIDA Phone- +91- 9810122070 Pincode : 201301 Email : naveensingh@vsnl.com	Works-1->S.R.SINGH/ NAVEEN SINGH B - 2, SECTOR - 6, - NOIDA-UTTAR PRADESH INDIA Phone- 0120-4352940 FAX : 0120-4352940 Pincode : 201301 Email : naveensingh@vsnl.com		Over all financial limit for ordering as Rs.30 lacs (Rs.Thirty Lacs).
70	145-45000-A	INSTRUMENT FITTINGS	Fluid Controls Pvt. Ltd.	Sophie Y. Moochhala/Mayur Rajput J.V.PATEL, I.T.I CMPD, B.MADHUKAR MARG, ELPHINSTONE ROADSTN.(WR), MUMBAI Phone- (022) 43338000 Pincode : 400013 Email : sales@fluidcontrols.com	Works-1->Mr. Tansen Choudhari/Mr. Mahesh Darekar Shed No.8, Lonavla Indl.Co-op.Estate Ltd,Nagargaon, - Lonavla-MAHARASHTRA INDIA Phone- 9823951347 FAX : (02114) 271132 Pincode : 410 401 Email : factory@hyd- air.com		

SUB-VENDOR LIST FOR C&I ITEMS

SI No	Package Code	Package Name	Supplier Name	Supplier Communication Address	Supplier Works Address	Tech Limit	Fin Limit
71	145-45000-A	INSTRUMENT FITTINGS	PANAM ENGINEERS	Mr. Santosh Shukla 203, Jaisingh Business, Parsiwada, Sahar road, Andheri(East), Mumbai, Phone- 9892179529, Pincode : 400099, Email : santosh@panamengineers.com	Works-1->Mr. Santosh Shukla Others R-628, TTC Industrial Area, MIDC Rabale, -Navi Mumbai-MAHARASHTRA India Phone- 9821350761, FAX : 022-27695559, Pincode : 400701, Email : sales@panamengineers.com		

Notes :-

- i) The above sub-vendor list is tentative & for reference only. However Sub-Vendor List is subject to BHEL/ end user approval without any commercial/ delivery implication.
- ii) New Sub-Vendor if proposed by Vendor during contract stage shall be subject to BHEL/ end user approval without any commercial/ delivery implication.



**2X500 MW NTPL TUTICORIN FGD
COMPRESSED AIR SYSTEM**

SPECIFICATION NO. PE-TS-483-555-A002

VOLUME : II B

SECTION : E / ANNEXURE-II

REV 00

DATE: FEB 2022

SHEET: 1 OF 1

**ANNEXURE-II
PAINTING & COLOUR SCHEME**



VOLUME : II-A
SECTION - V
PROTECTIVE COATING AND PAINTING





G. DRIVE MOTOR

Drive motor for compressor shall comply with the requirements of Clause No. 4.11.00 of this section and Volume IIF1 & IIF2 of this Specification.

H. COMPRESSOR ACCESSORIES

a) Intake Air Filter

Numbers required	:	One (1) no. with each compressor.
Location	:	Indoor/At the suction of each air compressor.
Type	:	Dry type.
Silencer	:	Yes
Air flow rate	:	To suit compressor rating.
Particle removing efficiency	:	99.9% up to particle size of 3 Micron.
Maximum allowable pressure drop at stated air flow rate in new condition of filter (viscosity of air at normal ambient temperature)	:	150 mm WG
Test requirement	:	No separate test. Compressor performance testing will include the filters in test set up. Capacity, pressure drop and efficiency shall be measured.

b) Air Receiver

Numbers required	:	One (1) for each Air compressor
Installation	:	Outdoor
Type	:	Vertical cylindrical with torispherical dished ends.
Design pressure	:	10 Kg/Sq.cm(g)
Hydraulic test Pressure	:	15 Kg/Sq cm(g)
Design code	:	IS-2825/IS-7938/ Approved equivalent code.





ANNEXURE-I

Capacity of each air receiver : Bidder to compute in accordance with Clause no. 4.13.00 of this section.

However, the water filled volume shall not be less than 2 M³ under any circumstances.

Material of construction of shell : IS-2002.

Material of construction of dished ends : IS-2002.

Material of construction of flanges : IS-2002.

Supply of Accessories & Services

Flanges with nuts, bolts and gaskets : Yes

Pressure gauge with snubber : Yes

Pressure switch : Yes

Temperature indicator : Yes

Relief valve : Yes, set pressure shall be at least 10% above working pressure.

Trap station : Yes

Level gauge : Yes

Vent valve/plug : Yes

Supporting stand with necessary foundation bolts, nuts, sleeves, etc : Yes

Eye bolts, lifting tackle, earthing lugs or pads etc. : Yes

Painting

i) External : Two coats of red-oxide primer and two finish coats of paints suitable for sea water environment.

ii) Internal : Shop painted as per manufacturer's standard suitable for sea water environment.





**DATA SPECIFICATION SHEET
OF
AIR DRYING PLANT AND AUXILIARIES**

A. General Information

Numbers of Air drying Plant (for FGD Plant)	:	Two (2) nos. - one (1) for each Air compressor.
Duty	:	Continuous.
Service	:	Instrument Air
Installation	:	Indoor.
Type of Drying	:	Adsorption.
Type of Reactivation	:	Heat of compression .
Desiccant	:	Silica gel as per IS-3401 / Activated alumina.
Outlet dew point	:	At least (-) 40°C at 1 atm pressure.
Annunciation	:	Local and remote.

B. Performance Specification

Air drying capacity	:	To suit the compressor capacity.
Inlet air pressure	:	To suit compressor rating.
Inlet air temperature	:	To be indicated by Bidder.
Maximum allowable air pressure drop	:	0.5 kg/sq.cm.

C. Material

Absorber vessels and its internal	:	SS-304.
Regeneration air cooler shell & tube sheet	:	SA-285 Gr. C or equivalent.
Relief valves	:	Brass or SS.
Tube of Heat exchanger	:	SS.
Desiccant	:	Silica Gel / Activated Alumina.





D. Supply Of Accessories And Services For Each ADP

Pre-filters and After Filters	:	2 × 100% with automatic drain trap filter arrangement, and ceramic candle type filters.
Dew point indicator	:	Yes
Instruments as per specification, Tender drawing and as required for safe and trouble free operation	:	Yes
Control panel with accessories	:	Yes
Tools and tackle	:	Yes
Spare parts	:	Yes
All interconnecting piping complete with fittings, valves etc	:	Yes
Insulation	:	Yes
Base frame, foundation bolts, nuts, sleeves etc.	:	Yes
Vessel internal point	:	Anti-corrosive.
Shop painting		
i) Internal	:	Anti-corrosive heat resistant paint suitable for sea water environment..
ii) External	:	2 coats of red-oxide primer (120 micron DFT) with finish paint suitable for sea water environment.

E. Inspection and Testing

Non destructive material test	:	Yes
Hydrostatic test	:	Yes
Performance tests at shop	:	Yes
Performance tests at site	:	Yes
Spot Radiography of welds parts to be tested	:	All pressure parts and vessels.
Dye Penetration test	:	Yes





CONTENTS

CLAUSE NO.	DESCRIPTION	PAGE NO.
1.00.00	INTENT OF SPECIFICATION	1
2.00.00	CODES & STANDARDS	1
3.00.00	GENERAL REQUIREMENTS	2
4.00.00	SURFACE PREPARATION	3
5.00.00	PAINT APPLICATION	7
6.00.00	INSPECTION	11
7.00.00	SPECIFICATION OF COATING SYSTEMS	15
8.00.00	TESTING REQUIREMENTS	23
9.00.00	INFORMATION / DATA REQUIRED	26
ANNEXURE-1	MARKET AVAILABLE COATING SYSTEMS AS PER SPECIFICATION	27





VOLUME : II-A

SECTION-V

PROTECTIVE COATING AND PAINTING

1.00.00 INTENT OF SPECIFICATION

1.01.00 This specification addresses the requirements of all labour, material, and appliances necessary with reference to preparations for lining / painting, application as well as finishing of all lining / painting for all mechanical and electrical equipment, piping and valves, structures etc. included under the scope of this Flue Gas Desulphurisation Plant package.

1.02.00 The bidder shall furnish and apply all lining, primers including wash primers if required, under-coats, finish coats and colour bands as described hereinafter or necessary to complete the work in all respects.

2.00.00 CODES & STANDARDS

2.01.00 The bidder shall follow relevant Indian and international standards wherever applicable in cleaning of surface, selection of lining material / paints and their application. The entire work shall conform to the following standards / specifications (latest revision or as specified).

- | | | | |
|----|--------------------------------|---|--|
| a) | SSPC SP 10 / NACE 2 /
SA 2½ | : | Near white blast cleaning |
| B) | SSPC PA 2 | : | Measurement of dry film coating thickness with magnetic gauges. |
| c) | ASTM D 45 | : | Method for pull off strength using portable adhesion tester. |
| d) | NACE RP 0274 – 2004 | : | High-voltage electrical inspection of pipeline coatings. |
| e) | NACE SP 0188 – 2006 | : | Discontinuity (holiday) testing of new protective coatings on conductive substrates. |
| f) | NACE RP 0169 – 2002 | : | Control of external corrosion of underground or submerged metallic piping systems. |





**Tender Specification
for
FGD Package**

**NLC Tamil Nadu Power Ltd.
2x500 MW Project
Tuticorin, Tamil Nadu**

- g) AWWA C 210 – 2007 : Liquid-epoxy coating systems for the interior and exterior of steel water pipelines.
- h) IS 3589:2001 Annexure-b : Steel pipes for water and sewage specification.
- i) AWWA C 222-2000 : Polyurethane coating for the interior and exterior of steel water pipe and fittings.
- j) IS 13213 : 2000 : Polyurethane full gloss enamel (two pack)
- k) ISC HD 20 (11902) : Polyurethane coating for interior and exterior of steel pipe and fittings.
- l) ISC HD 20 (11055) : Solvent less liquid epoxy system by application of interior and exterior surface of steel pipeline.
- m) IS 10221 : Coating and wrapping for buried piping

3.00.00 GENERAL REQUIREMENTS

3.01.00 The bidder shall submit a detailed written description in the form of a manual covering coating equipment, procedures, materials inspection test, and repair etc. to owner/consultant for approval.

3.02.00 The bidder shall also provide certificates from paint/primer manufacturer mentioning the batch numbers, date of manufacture and shelf life etc. of the materials to be used. In addition to that manufacturing quality plan (MQP) and field quality plan (FQP) shall also be submitted prior to commencement of supply of material and field application.

3.03.00 Paint/coating application work at site shall be done either by paint manufacturer or by their authorized applicator. The authorized applicator shall have proper training & certification from manufacturer. Applicator shall possess all the necessary specialized equipment and manpower experienced in similar job.

3.04.00 If necessary, the material may be heated and applied by airless spray / plural component spray system.



Development Consultants Pvt. Ltd.

**Vol. II-A/Section-V
Protective Coating & Painting**



- 3.05.00 Manufacturer's specific recommendation, if any, shall be followed during application of lining / paints.
- 3.06.00 In areas where there is danger of spotting automobiles or other finally finished equipment or building by wind borne particles from paint spraying, a purchaser approved method shall be adopted.
- 3.07.00 The colour scheme of the entire FGD Plant equipment and auxiliaries area, covered under this specification shall be approved by the purchaser in advance before application.
- 3.08.00 All indoor and outdoor piping, insulated as well as uninsulated will have approved colour bands painted on the pipes at conspicuous places throughout the system, as approved by purchaser.
- 3.09.00 Inside surfaces of vessels / tanks shall be protected by anticorrosive paints or rubber lining as required / specified elsewhere in the specification. External surfaces of all vessels / tanks shall be protected by anti-corrosive painting.
- 3.10.00 For vessels / tanks requiring lining and anti-corrosive painting all inside surface shall be blast cleaned using non-siliceous abrasive after usual wire brushing.
- 3.11.00 Natural rubber lining shall be provided on the inside of vessels / tanks as required / specified elsewhere in the specification, in three layers resulting in a total thickness not less than 4.5 mm.
- 3.12.00 Surface hardness of rubber lining shall be 65 +/- 5 deg. A (shore).
- 3.13.00 After the lining is completed, the vessels / tanks shall not be subjected to any prolonged exposure to direct sunlight in course of its transportation, erection etc. They shall not be stored in direct sunlight. No further lining or burning shall be carried out on the vessel, after application of the lining.
- 3.14.00 All lining projecting outside of the vessel shall be protected adequately from mechanical damages during shipment, handling storage etc.
- 3.15.00 Suitable warnings, indicating the special care that must be taken with respect to these lined vessels shall be stenciled on their outside surface with the letters at least 12 mm high.
- 3.16.00 All insulated piping shall have aluminium sheet jacketing.
- 4.00.00 SURFACE PREPARATION**
- 4.01.00 Most metallic articles that are usually given protective coatings are heavily contaminated and require, at least, some cleaning treatment before the coating is applied. The importance of surface preparation cannot be over emphasized as many investigations have shown convincingly that the performance and durability of any protective coatings are, to a large extent governed by the thoroughness of surface preparation. Often they concluded





that careful cleaning and preparation of the surface were more important than the quality of the protective coating.

4.02.00 Surface contamination in the form of rust, scale, oil grease and dirt is often obvious. Invisible contamination may also be present and represents, on the whole, a greater hazard. Examples of the latter are soldering fluxes, perspiration in the form of hand marks, chlorides from marine atmosphere and sulfite from industrial atmosphere.

4.03.00 The following table gives a surface preparation specification in the descending order of Effectiveness:

Sl. No.	Methods of cleaning	Specifications NACE/SSPC
1.	White metal blast	NACE # 1, SSPC SP 5-63
2.	Near –white metal blast	NACE # 2, SSPC SP 10-63
4.	Acid Pickling	SSPC SP 8-63
5.	Brush Blast	NACE # 4, SSPC SP 7-63
6.	Flame Clean and Power Sanding	SSPC SP 4-63
7.	Power Tool Cleaning	SSPC SP 3-63
8.	Chip and Hand Wire Brush	SSPC SP 2-63
9.	Solvent Wipe	SSPC SP 1-63

4.04.00 The following table gives the Specifications for sand / shot / grit blasting

Sl. No.	Methods of Cleaning	Specification
1.	NACE # 1	White sand blast
2.	NACE # 2	Near-white sand blast
3.	NACE # 3	Commercial blast
4.	Pickle, phosphate treated	
5.	NACE # 1	Grit
6.	NACE # 1	Shot
7.	NACE # 4	Brush blast
8.	No surface preparation	

4.05.00 Inspection of blasted steel surface

For the purpose of inspecting the blasted steel surface with sand abrasive, the respective “Visual standards” shall be utilized.

The standards used in industry to describe surface preparation are:

- i. National association of Corrosion Engineers (NACE)
- ii. Steel Structural Painting Council (SSPC)
- iii. Swedish Pictorial Standards

White metal blast (SSPC 5-63, NACE No.1, and SA-3)

This is defined as removing all rust, scale, paint etc. to a clean white metal which has a uniform Grey white appearance. Streaks and stains of rust or





other contaminants are not allowed.

Near white metal (SSPC 10-63, NACE No.2, SA – 2.5)

This provides a surface of about 95% as clean as white metal. Light shades and streaks are not allowed.

Commercial blast (SSPC 6-63, NACE No.3, SA –2)

This type of blast is more difficult to describe. It essentially amounts to about 2/3 of a white metal blast, which allows for very slight residues of rust and paint in the form of staining.

Brush of blast (SSPC 7-63, NACE No.4 SA-1)

This preparation calls for removal of loose rust, paint, scales, etc. Tightly adherent paint, rust and scale is permitted to remain.

4.06.00 Pictorial Standards of different surface preparation to be adopted

During surface preparation operations, the surface condition obtained shall be compared with pictorial standards available for getting the specified condition. These pictorial standards are available in steel structural painting Manual (Vol. 1), "Good painting practice ", visual standards of surface cleaning sp 7,6,10 and 5 are described in page No.185 and 186 viz. Fig 9,11,12 and 13.Surface profile gauge and surface compactor could be used to check surface conditions according to NACE standard TM 01 70 of NACE.

4.07.00 PRESSURIZED WATER CLEANING METHODS

These standards provides requirements for the use of high and ultra-high pressure water jetting to achieve various degrees of surface cleanliness. This standard is limited in scope to the use of water only without the addition of solid particles in the stream. These standards define four levels of working pressure:

SSPC-SP WJ-1/NACE WJ-1:	Water-jet cleaning of metals. Clean to bare substrate.
SSPC-SP WJ-2/NACE WJ-2:	Water-jet cleaning of metals. Very thorough cleaning.
SSPC-SPWJ-3/NACEWJ-3:	Water-jet cleaning of metals. Thorough cleaning.
SSPC-SP WJ-4/NACE WJ-4:	Water-jet cleaning of metals. Light cleaning.





This cleaning standard defines 4 levels of cleanliness for visible contamination by water jetting and 3 levels for non-visible contamination, such as chlorides and other soluble salts. See the full standard for complete definitions on the level of cleanliness.

4.08.00 SPECIFICATIONS FOR COPPER SLAG BLASTING:

1. The surface shall be cleaned of all dust and heavier layers of rust by copper slag blasting the entire internal surface to photographic standard SIS: 055900- 1967.
2. The consumption rate of copper slag is 1.6 Kg/Sqm of the blasted area. This has to be ensured strictly.
3. All tools, equipment, base material, hand and power tools for cleaning, including scaffolding material, copper slag blasting equipment, air compressor, etc. shall be arranged by the contractor at site in sufficient quantity.
4. The compressor used shall be of size enough to produce displacement of 5.6 to 7.0 Cum/Min of air at a pressure of 7 Kg/sq.cm. Standard blasting equipment, hoppers, hoses nozzles and attachments shall be used to obtain best test results and to maintain safety standards. The rate of cleaning shall be about 15 sq.mt. per hour at a pressure of 7 kg/sq.cm.
5. The abrasive used shall be of the physical properties as mentioned below and shall be free from oil, loan and mud etc.
6. The blast cleaned surface shall be blasted with dry compressed air before applying primer. This should be done even if the surface appears very clean and white in colour. The white colour may be due to deposition of silicon and reflection of light on the surface.
7. Proper earthing and bonding arrangements shall be made to prevent any damage by sparks produced by static electricity. Bonding shall be done between tank and blast nozzles and hopper and air compressor also. The bonding conductor should not be less than 16 SWG single strand copper cable.
8. The time gap between blast cleaning and application of primer shall not be more than THREE hours. Blast cleaning work shall, commence from top to bottom.
9. The blast cleaning operation shall be carried out keeping the nozzle at an angle of 30 degree to the vertical in order to prevent rebounding abrasive from showing down the abrasives emerging from nozzle and from under cutting the material to be removed.
10. A blast cleaning, the percentage of bare metal obtained shall be between 95% to standards of SA 2 ½ of the Swedish standard referred above. (Pictora) surface preparation standards for painting steel surfaces).





11. Arrangements for inspection of various stages of the job shall be made available by the Contractor so that the entire sand blasted area is available for inspection. Any defective work noticed shall be immediately rectified and even reblasting shall be done if necessary.

5.00.00 PAINT APPLICATION

The coating is a unique product. It is only after application on the substrate a coating becomes valuable and useful. The manufacturer shall produce high performance liquid coatings, yet the product usefulness lies in the hands of the applicator. That is the reason why stress is given for proper and careful application as a key to the success of any coating. Protection by coating mainly depends upon three factors

- a) The material
- b) The surface preparation
- c) The application

If any one of the three is weak, protection value is affected to that extent.

High performance coatings are especially sensitive to misapplication and may fail drastically. Therefore, it is imperative that the instruction for application be followed explicitly, particularly when applying sensitive and expensive high performance coating systems.

The purpose of coating application is to develop a continuous highly adherent film with an even thickness over the substrate. To achieve this, various factors have to be considered such as type of coatings and weather conditions, application methods etc. It is advisable to avoid painting below 10⁰C and above 40⁰C, if the relative humidity is above 80%, during the rainy weather and wind velocity is above 24km/hr or else freezing will occur before the paint dries.

5.01.00 Application methods

There are a number of methods by which coatings can be applied. The two principal methods are by brush and spray. The other methods are paint pad applications, electrostatic spray, electro-coating, dipping and fluidized bed technique. The latter methods are primarily for in-plant application.

The choice of application methods depends on a number of factors. The first is the type of coating. Most of the oil-based coatings can be easily applied by brush but it is the slowest process. Spray application is the fastest for large flat surfaces. The type of surface is also a factor. For small and intricate areas, brushing is probably the best method. If the surface is used and pitted, application of the first coat by brushing is probably the best method.

Brushing can be done in almost all areas, since the liquid coating is transferred from the brush to the surface. Spraying however, causes problem with toxic solvents as well as a possible fire hazard due to fume build up.





Spraying in small, enclosed areas are usually not suggested. Clean up is also a factor. Cleaning a brush is the least difficult procedure and cleanup of spray equipment is the most time consuming and most complicated procedure.

5.02.00 Storing and handling of paints

Coating materials (paint) as they are packed at the manufacturing plant are thoroughly dispersed, with the pigments fully suspended and of a uniform consistency in terms of both texture and colour. Unfortunately, very few coatings are applied within a short time after manufacture. They may be placed in inventory at the manufacturing plant or sent to a distribution point where they will be held for a period of time. Also, the coating material may be purchased several months before its actual use and again under different conditions. Thus, coatings generally must be remixed and properly re-dispersed prior to actual application.

A pigment, which is usually heavier than the vehicle, tends to settle and may even cake at the bottom of the container. Coatings vary to a wide degree in this particular characteristic. Some may stay suspended for many years; others settle out hard at the bottom of the container. This is a defect. Paints, which gelled in the container or in which the pigment liveried (i.e. become thick and rubbery) are not satisfactory for use and cannot be practically re-dispersed. The formulation has to contain proper antissettling additive to avoid this defect.

The purpose of remixing and re-dispersion is to make the coating completely homogeneous, so that upon application the pigment and vehicle can produce the film that was intended by the manufacturer. In certain cases, particularly in oil-type vehicles, there may be skin on the surface of the liquid. These should be removed before re-dispersion, since they will not get re-dispersed into the vehicle.

5.03.00 Mixing

The mixing process is not practically easy, even if the system has not settled hard. This is often neglected by applicators, particularly in coatings, which have settled rather solidly. There have been examples of coatings that were applied with at least half of the pigment remaining at the bottom of the container un-dispersed and later thrown away with the container. This procedure does not allow for the maximum performance of coating properties and normally leads to rapid coating failure.

Mechanical mixing

It is always better to use a mechanical mixer of some type, since mechanical mixing always produces a more uniform coating and does so much more rapidly than manual mixing. Manual mixing should only be done under unavoidable circumstances and only in containers with the maximum of a 20-liter capacity.





Even when the coating has settled rather hard, the propeller-type agitator can break it up and re-disperse it to a point, which is closely equivalent to its original form. Nevertheless, care should be taken in the mixing operation, particularly to ensure that the material at the bottom and lower sides of the container has been well separated from the container and re-dispersed. Some materials form soft sediment, which clings to both the sides of the container and the bottom, making it necessary to scrape these off before they can be properly dispersed. This is usually done by manual operation. The mixing should be done in such a manner that splashing is avoided.

The speed of a mechanical mixer should be as low as possible in order to obtain the re-dispersion of the pigment in the vehicle. The coating should have a slight vortex at the surface. A large vortex tends to mix air into the coating, which can cause pinholes and air bubbles during application.

Manual mixing

If the manual mixing is necessary, the liquid portion of the coating should be separated into a clean container. The lower, thicker part of the coating can then be more readily mixed into a heavy paste, including the material, which is clinging to the sides of the container. Once the heavier material is mixed into a smooth paste, the remainder of the liquid from the second container can be remixed into the original container with the heavy material, making sure that the two are thoroughly mixed into a uniform coating. One way to do this is to pour the material back and forth between the two containers. This is called boxing. The materials should be poured back and forth several times to assure complete uniform mixing.

5.04.00 Two component coatings

In the case of two component coatings, there are two materials that must be checked to determine whether or not they are properly dispersed prior to being mixed together. Two component coatings are extremely common at the present time. They include numerous kinds of epoxy coatings, coal tar epoxy coatings, polyurethane coatings, and inorganic zinc coatings. With two component coatings, it is essential that the two components be separately and thoroughly mixed. Two component materials are designed to react chemically, so that if they are not thoroughly mixed, the chemical reaction may not take place properly. Mechanical blending of the two components is recommended to obtain a thoroughly mixed product. The two component materials often are in different colours so that a satisfactory mixing can be readily identified. The fully mixed coating should have a uniform colour and consistency.

5.05.00 Mixing dry powder and liquid

The primary example of mixing dry powder and liquid components is in the use of inorganic zinc coatings. In-organic zinc coatings are made from liquid component and dry powdered zinc. The first step is to determine whether or not the liquid component is thoroughly mixed and dispersed to a completely





homogeneous liquid. This usually is not difficult since most liquid components are lightly pigmented.

Second, stir the total contents of the powder slowly into the total content of the liquid until it becomes a well dispersed, free flowing material. In the case of inorganic zinc coatings, the manufacturers supply the liquid and the powder in two different containers in the exact amount that should be mixed. It is essential that the total powder and total liquid be used in order to obtain the desired final coating. Mixing small portions of zinc and liquid is not recommended, since correct proportions are seldom measured under field conditions.

5.06.00 Straining

Most coatings are thoroughly strained prior to being placed in their container. When the container is opened, if the contents have not settled to a hard deposit in the bottom, straining in the field may not be necessary. On the other hand, if the pigment has settled hard, if the coating has a skin on the surface, or if the product is a material such as inorganic zinc, straining is recommended. Straining prior to spraying often eliminates considerable downtime due to gun clogging by small particles those blocks the orifice in the gun.

Straining can be done with a fine fly screen with a mesh size 150µm or through nylon stocking. Nylon stocking does not contain any lint and is a very fine mesh that most coating materials can readily pass through. Mosquito netting or similar materials also are used, although they often contain some lint, which can cause problems.

5.07.00 Compatibility of different paints

While applying multicoated system of paint it is always desirable to have a first-hand knowledge of compatibility of different coating systems with one another. A general view of such information is given in the following table. This is only a general view.

Primer	Oleo resinous	Alkyd	Silicone alkyd	Vinyl	Chlorinated rubber	Epoxy (2 pack)	Urethane
Oleoresins	C	C	C	NR	NR	NR	NR
Alkyd	C	C	C	NR	NR	NR	NR
Silicone alkyd	C	C	C	NR	NR	NR	NR
Phenol resin	C	C	C	NR	NR	NR	NR
Vinyl	C	C	NR	C	C	C	NR
Chlorinated rubber	C	C	C	C	C	NR	NR
Epoxy	NR	NR	NR	C	C	C	C
Coal tar epoxy	NR	NR	NR	NR	NR	C	NR





Zinc-rich epoxy	NR	NR	NR	NR	C	C	NR
Inorganic zinc	NR	NR	NR	C	C	C	NR
Urethane	NR	NR	NR	NR	NR	NR	C

TE: C-Normally

NOTE: C-Normally compatible; NR- Not recommended due to known or suspected problems. Certain combinations marked "NR" may be used provided a suitable tie coat is applied.

6.00.00 INSPECTION

Inspection techniques shall be applied at various stages i.e. from purchase of coating materials to paint application and evaluation of performance during service. Inspection procedures at various stages before and after the application of coating systems over the oil installations have been described below:

6.01.00 Paint composition

The type of paint system shall be selected depending upon the environmental conditions. Generally primer, undercoat and finish coats are used in protective coating system. The purchased paint materials are used in protective coating system. The purchased paint materials shall be tested for the following properties to ascertain whether the supplied paint conforms to the specifications.

- i. Type of film formers present
- ii. Type of pigments present
- iii. Thickness per coat
- iv. Volume solids
- v. Pigment volume concentration
- vi. Area coverage per liter of the paint
- vii. Specific gravity
- viii. Drying time and
- ix. Main pigment content in total pigmentation

It is the duty of the inspection engineer to get the paint system tested for the above factors. The painting operation shall be started only after the values obtained coincide with the required specification of the paint system.

It is essential to see that the surface is not wet during the application of the paint. Moreover paints should not be applied when the humidity of the environment is above 80%. The atmospheric temperature should not be below 10°C during the painting operation.





6.02.00 Procedure for testing paint samples

The following laboratory test procedures shall be adopted for the characterization of the film-formers, pigments and studying the properties of the paint.

a) Type of film-formers present

The film former shall be separated out of the paint by means of centrifuging. It is then to be analyzed using infrared spectroscopy for identifying the functional group. i.e. the type of film formers.

b) Type of pigments present

After separating the pigment from the paint and proper drying, it shall be subjected x-ray diffraction for identifying the pigment.

c) Thickness per coat

Magnetic thickness gauges are used to measure the thickness of the paint film applied over the iron-substrate. The thickness is measured in micrometer (μm). Some of the thickness gauges operating under magnetic principle are elecometer, posi test and micro test. Thickness gauges operating on eddy current principle are used to measure coating thickness over metals other than steel/magnetic substrates.

d) Volume solids

Paint is a mixture of three major components such as pigment, binder and thinner.

The pigment and film-former will remain in the paint film after the evaporation of the solvent. The pigment and film former together are called as solids. The volume of these together in the liquid paint is called as volume solids. This is determined as follows:

A known volume of the paint is taken. Let it be V1. Distilling the solvent and collecting it in a measuring cylinder determine the volume of the solvent present of the paint. Let it be V2. By subtracting V2 from V1, we can determine the volume solids.

e) Pigment volume concentration (PVC)

Pigment volume concentration is defined as

$$\text{PVC} = \frac{\text{Volume of pigment}}{\text{Volume of pigment} + \text{Volume of binder}} \times 100$$

By separating out the pigment and binder from the paint and knowing their specific gravity, we can calculate PVC.

f) Area coverage per liter of the paint





This is determined by taking a known volume of the paint and applying it over a surface. The area covered by the known volume of the paint is determined. From this value, area covered by one liter of the paint is calculated.

g) Specific gravity

For determining specific gravity, a cup of known volume is taken. The difference in weight of the cup filled with paint and the empty cup gives the weight of paint of known volume. From this, we can calculate specific gravity.

h) Drying time

i) Touch Dry

In this case, if the coated surface is touched with finger, no finger mark should be found on the coating.

ii) Hard Dry

It is the condition of coating drying very hard. Unless the coating itself is damaged with force, no pressure could mar the coating in this condition. This condition is attained usually after seven days.

i) Flow properties (viscosity) of the paint (Ford cup method)

Ford cup is the mostly used instrument for studying the flow properties of the paint. Ford cups having different orifice sizes are available in the market. The varying orifice sizes are meant for measuring the flow time of different viscosities. Generally, the most viscous liquids require bigger orifice. The results are reported simply as seconds per cup. Number

6.03.00 Spot testing procedures

The following spot tests will be useful to identify the binders (film-formers) qualitatively before application at the site.

a) EPOXY RESIN

i) Filter paper test

This test can be carried out even with paint itself. 0.5 gms of paint part (binder part) / binder is taken in a 100 ml beaker and treated with 1ml concentrated sulfuric acid. The beaker is slightly heated at 60°C for a few minutes. It is again mixed with 5ml of conc. H₂SO₄ until the colour intensity is similar to that of very dilute potassium-di-chromate solution. A drop of the solution is taken in a glass rod and is spread over a filter paper. If Bis-phenol-A-type of epoxy resin is present, a purple colour develops in 1 minute, the colour eventually turns blue.





**Tender Specification
for
FGD Package**

**NLC Tamil Nadu Power Ltd.
2x500 MW Project
Tuticorin, Tamil Nadu**

ii) Formaldehyde Test

Few drops of the sample is dissolved in 1 to 2 ml of concentrated sulphuric acid if necessary by heating to 40°C to 50°C. One to two drops of formaldehyde solution is added in to it. An orange colour, which on dilution with water turns violet to blue indicates the presence of epoxy resins.

b) Chlorinated rubber resin

Few milligrams of the sample is allowed to stand in pyridine at room temperature for few minutes. Few drops of methanolic potassium hydroxide solution is added in to it. If chlorinated rubber resin is present in the solution, a yellow precipitate is formed which gradually darkness to a yellow-brown colour.

c) Isocyanate hardener

The aliphatic nature of isocyanate is confirmed by the following spot test. A small sample of isocyanate hardener is heated in a test tube until white fumes are evolved and these fumes are absorbed on a filter paper. One drop of a solution of 4-nitrobenzene-di-azofluoroborate in methanol (1%) on the filter paper should give any coloration, confirms the presence of aliphatic isocyanate. If any coloration is seen on the filter paper, this will confirm the presence of aromatic isocyanate

The infrared spectra of the aliphatic isocyanate will show peaks at 1370 cm⁻¹ and 2250-2350 cm⁻¹.

Physical, Chemical and Instrumental methods of paint analysis with their relevant standards are given in the following tables.

i) Physical Tests

Paint property	IS Standard	ASTM
Preparation of panels	IS 101 PART1 – SEC3	D 609
Preparation of Tin panels	IS 101 PART1 – SEC3	D 609
Viscosity (KU)	IS 101 PART1 – SEC5	D 562
Weight per Gallon	IS 101 PART1 – SEC 7	D 1475
Fineness of Grind	IS 101 PART3 – SEC 5	D 1210
Water content	IS 101 PART2 –SEC 1	D 95
Coarse particles and skins		D 185
Drying times Set to touch Dry for recoating Dry hard	IS 101 PART3 – SEC 1 & 2	D 1640
Pigment content	IS 101 PART8 – SEC 2	D 2371
Vehicle content		D 2371
Non – volatile content	IS 101 PART2 – SEC2 & PART8 – SEC –2	D 2369
Adhesion	IS 101 PART5 – SEC2	D 3359
Brushing properties	IS 101 PART1 – SEC4	





Exposure tests of paints on metals		D 1014
Salt spray resistance	IS 101 PART6 – SEC1	B 117
Accelerated weathering	IS 101 PART6 – SEC5	D 822
Leafling		D 480
Flexibility	IS 101 PART5 –SEC	D 522

ii) Chemical Tests

PAINT PROPERTY	TEST METHOD (ASTM)
Chemical resistance	D 1308
Liquid dryers	D 564
Aluminum	D 480
Aluminum silicate	D 718
Calcium carbonate	D 34
Extenders in colors	D 126
Iron oxide	D 768, D 50
Leaded zinc oxide	D 34
Red lead	D 49
Water soluble salts	D 2448, D 2455
Zinc oxide	D 34
Zinc powder	D 521
Zinc sulfide	D 34

iii

) Instrumental Tests

Paint property	Test method (ASTM)	Instrument
Dry Opacity	A 2805	Reflectometer
Gloss	D 523	Gloss meter
Color	D 2244	Colorimeter
Vehicle Identification	D 3168 D 3271	Infrared spectrophotometer Gas chromatograph
Solvent solids Identification	D 3271	Gas chromatograph
Vehicle solids Identification	D 2621	Infrared spectrophotometer

7.00.00 SPECIFICATION OF COATING SYSTEM

7.01.00 Protective coating for steel structures

Most commonly used coating system for atmospheric zone of blast cleaned steel structures are given below:

7.01.01 System-1





Tender Specification
for
FGD Package

NLC Tamil Nadu Power Ltd.
2x500 MW Project
Tuticorin, Tamil Nadu

Coating system used for atmospheric open exposure zone is one coat of inorganic zinc-rich primer, one coat of epoxy-Glass flake filled intermediate coating and one coat of aliphatic polyurethane provides better performance in more aggressive services. The coating system for closed atmosphere is also the same system with the replacement of aliphatic urethane with aromatic polyurethane top coat. The surface preparation of this Zinc rich primer requires sand blasted surface or grid blasted surface to the Swedish Specification of Sa 2.5. The coating systems are to be applied by spray method. The specification of the system is as given below:

i. Specification of Inorganic zinc rich primer

Colour	Green Grey
Gloss Level	Matt
Volume Solids	63%
Typical Thickness (DFT)	70-80 microns
Theoretical Coverage	8.40 m ² /litre
Method of Application	Airless Spray, Air Spray
Drying Time	One Hour
Volatile Organic Compound	216 g/ Litre
Mix Ratio	Liquid Binder Base part(A) 3: Powder Zinc component part (B)1
Working Pot Life	2-2.5 hours
Shelf Life	1 year

ii. Specification for glass flake filled epoxy coating

Colour	As desired
Finish	Semi-Glossy
Type	Two packs
Application	By brush or spray
Dry film thickness/coat	100– 110 μm
Volume solids	Approx. 90 ± 2 %
Area coverage (theoretical)	8 to 9 sq.m/ litre
Surface dry	4 hrs.
Hard dry	24 hrs.
Over coating	24 hrs.
Recoatibility	24 hours.
Full cure	1 week.
Shelf life	12 months

iii. Specification for Aliphatic Polyurethane top coat for open zone

Colour	Required colour
Gloss Level	Glossy
Volume Solids	63±2%
Typical Thickness (DFT)	50-60 microns
Theoretical Coverage	8 - 9 m ² /litre
Method of Application	Airless Spray, Air Spray
Guiding data for airless spray:	
Nozzle tip (inch/1000)	15-21





**Tender Specification
for
FGD Package**

**NLC Tamil Nadu Power Ltd.
2x500 MW Project
Tuticorin, Tamil Nadu**

Pressure at nozzle (minimum)	150 bar/2100 psi
Drying Time	One Hour
Volatile Organic Compound	340 g/ Litre
Mix Ratio	Acrylic Polyol Base part 5: Aliphatic Isocyanate Hardener part 1
Working Pot Life	3 hours
Shelf Life	2 years

iv. Specification for Aromatic Polyurethane top coat for closed zone

Colour	Required colour
Gloss Level	Glossy
Volume Solids	63±2%
Typical Thickness (DFT)	50-60 microns
Theoretical Coverage	8-9 m ² /litre
Method of Application	Airless Spray, Air Spray

Guiding data for airless spray:

Nozzle tip (inch/1000):	15-21
Pressure at nozzle (minimum):	150 bar/2100 psi
Drying Time	One Hour
Volatile Organic Compound	340 g/ Litre
Mix Ratio	Acrylic Polyol Base part 5: Aliphatic Isocyanate Hardener part 1
Working Pot Life	3 hours
Shelf Life	2 years

7.01.01 System-2

The surface preparation is not possible through blast cleaning, then the surface is cleaned with wire brushing or power tool cleaning and coated with two coats of non aluminium epoxy mastic followed by an aliphatic polyurethane coating is recommended.

i. Specification for non aluminium Epoxy mastic paint (High build)

Colour	As desired
Finish	Semi-Glossy
Type	Two pack
Application	By brush or Airless spray
Dry film thickness/coat	100-110 microns
Volume solids	Approx. 80 ±2 %
Area coverage (theoretical)	6 to10 sq.m/litre
Surface dry	4 hrs.
Hard dry	12 hrs.
Recoatibility	24 hours.
Full cure	7 days.
Shelf life	months (or as recommended by manufacturer)

ii. Specification for Aliphatic Polyurethane top coat for open zone





**Tender Specification
for
FGD Package**

**NLC Tamil Nadu Power Ltd.
2x500 MW Project
Tuticorin, Tamil Nadu**

Colour	Required colour
Gloss Level	Glossy
Volume Solids	63±2%
Typical Thickness (DFT)	50-60 microns
Theoretical Coverage	8-9 m ² /litre
Method of Application	Airless Spray, Air Spray

Guiding data for airless spray

Nozzle tip (inch/1000):	15-21
Pressure at nozzle (minimum):	150 bar/2100 psi
Drying Time	One Hour
Volatile Organic Compound	340 g/ Litre
Mix Ratio	Acrylic Polyol Base part 5: Aliphatic Isocyanate Hardener part 1
Working Pot Life	3 hours
Shelf Life	2 years

7.02.00 Protective coating system for Pipelines without Cathodic Protection

There are a number of factors to be considered for the selection of an external pipeline coating including physical and chemical stability of the coating in the pipeline environment, adhesion, and resistance to impact. The pipeline should be cleaned and prepare the surface for painting as follows:

The pipeline surface shall be cleaned. The main objective of surface preparation is to ensure that all contamination (rust, mill scale, etc.) is removed to reduce the possibility of initiating corrosion so that a surface profile is created that allows satisfactory adhesion of the paint to be applied. The surface of the pipe is cleaned with a wire brush or power tool cleaning to get the surface of Sa 2/St 3. Thus prepared surface to be cleaned with lint free cloth, which also includes cleaning & dewatering (in case of valve chamber) and drying the surface. After preparing the surface of the pipe for painting, the primer coat, undercoat and finish coat shall be applied. The coating system recommended for the pipeline is high build epoxy mastic coating as primer followed by an epoxy glass flake filled coating with the top coat of aliphatic polyurethane. The specifications of the systems are given below:

i. Specification for Epoxy mastic paint (High build)

Colour	As desired
Finish	Semi-Glossy
Type	Two pack
Application	By brush or Airless spray
Dry film thickness/coat	100-110 microns
Volume solids	Approx. 80 ±2 %
Area coverage (theoretical)	6 to10 sq.m/litre
Surface dry	4 hrs.
Hard dry	12 hrs.
Recoatibility	24 hours.





**Tender Specification
for
FGD Package**

**NLC Tamil Nadu Power Ltd.
2x500 MW Project
Tuticorin, Tamil Nadu**

Full cure	7 days.
Shelf life	12 months (or as recommended by manufacturer)
ii. Specification for glass flake filled epoxy coating	
Colour	As desired
Finish	Semi-Glossy
Type	Two packs
Application	By brush or spray
Dry film thickness/coat	100– 110 µm
Volume solids	Approx. 90 ± 2 %
Area coverage (theoretical)	8 to 9 sq.m/ litre
Surface dry	4 hrs.
Hard dry	24 hrs.
Over coating	24 hrs.
Recoatibility	24 hours.
Full cure	1 week.
Shelf life	12 months
iii. Specification for Aliphatic Polyurethane top coat for open zone	
Colour	Required colour
Gloss Level	Glossy
Volume Solids	63±2%
Typical Thickness (DFT)	50-60 microns
Theoretical Coverage	8-9 m ² /litre
Method of Application	Airless Spray, Air Spray
Guiding data for airless spray:	
Nozzle tip (inch/1000):	15-21
Pressure at nozzle (minimum):	150 bar/2100 psi
Drying Time	One Hour
Volatile Organic Compound	340 g/ Litre
Mix Ratio	Acrylic Polyol Base part 5: Aliphatic Isocyanate Hardener part-1
Working Pot Life	3 hours
Shelf Life	2 years

7.03.00 Protective coating for all other surfaces

The surface shall be cleaned with wire brushing or by power tools (St3). These structures will be protected by three layer system of Epoxy zinc rich primer followed by Glass Flake filled epoxy and aliphatic polyurethane finish coat. The specifications of the coating system are given below:

i. Specification for Epoxy Zinc rich primer

Colour	Grey
Finish	Matt
Type	Two pack
Application	By brush or spray





**Tender Specification
for
FGD Package**

**NLC Tamil Nadu Power Ltd.
2x500 MW Project
Tuticorin, Tamil Nadu**

Pigment (Main)	Zinc dust (30-40% by wt. of the total pigments.)
Type of epoxy	Condensation product of bisphenol-A and Epoxide equivalent Epichlorohydrin with terminal Epoxide groups 450-500
Curing agent	Polyamide (amine value 210-230)
Dry film thickness/coat	50-60 μ m
Volume solids	55 \pm 2% (volume)
Area coverage (theoretical)	11 to 14 sq.m/litre
Surface dry	2-3 hrs.
Hard dry	24 hrs.
Re-coatability	24 hours.
Full cure	5 days.
Shelf life	6 months under sealed conditions

ii. Specification for Epoxy glass flake paint

Colour	As desired
Finish	Semi-Glossy
Type	Two packs
Application	By brush or spray
Dry film thickness/coat	100–110 μ m
Volume solids	Approx. 90 \pm 2 %
Area coverage (theoretical)	8 to 9 sq.m/ litre
Surface dry	4 hrs.
Hard dry	24 hrs.
Over coating	24 hrs.
Re-coatability	24 hours.
Full cure	1 week.
Shelf life	12 months

iii. Specification for aliphatic Polyurethane top coat

Colour	Required colour
Gloss Level	Glossy
Volume Solids	63 \pm 2%
Typical Thickness (DFT)	50-60 microns
Theoretical Coverage	8-9 m ² /litre
Method of Application	Airless Spray, Air Spray

Guiding data for airless spray:

Nozzle tip (inch/1000):	15-21
Pressure at nozzle (minimum):	150 bar/2100 psi
Drying Time	One Hour
Volatile Organic Compound	340 g/ Litre
Mix Ratio	Acrylic Polyol Base part 5: Aliphatic Isocyanate Hardener part-1
Working Pot Life	3 hours
Shelf Life	2 years





7.04.00 Summary of Specification of Coating System

The summary of the coating system shall be as mentioned below:

Area	Surface preparation	Recommended coating scheme
Directly exposed to Sunlight- Steel structures	Copper shot blasting to Sa2.5	Scheme I
	Power tool cleaning to St3	Scheme II
Indoor –Steel Structures	Copper shot blasting to Sa2.5	Scheme III
	Power tool cleaning to St3	Scheme IV
Pipelines (over ground)	Power tool cleaning to St3	Scheme V
All other surfaces	Wire brushing / Power tool cleaning to St3	Scheme VI

7.04.01 Scheme-I: For blast cleaned structures and exposed to sunlight

For new steel structures/Existing steel structures	Exposed to sun light Outdoor)	
Surface preparation	Copper slag blasting to Sa2.5	
Primer	Zinc ethyl silicate	50 – 60µm
Undercoat	Epoxy Glass flake (high build)	100 – 110 µm
Top Coat	Aliphatic polyurethane (TiO ₂) rutile	50 – 60µm
Total dry film thickness (DFT)		200 –230µm

7.04.02 Scheme-II: For under prepared structures and exposed to sunlight

For new steel structures/Existing steel structures	Exposed to sun light (Outdoor)	
Surface preparation	Power tool cleaning St-3/Paint strippers	
Primer	Epoxy mastic(non aluminium)	100 – 110µm
Undercoat	Epoxy mastic(non aluminium)	100 – 110 µm
Top Coat	Aliphatic polyurethane (TiO ₂) rutile	50 – 60µm
Total dry film thickness (DFT)		250 –280µm

7.04.03 Scheme- III: For blast cleaned structures and not exposed to sunlight





For new steel structures/Existing steel structures	Not exposed to sunlight (Indoor)	
Surface preparation	Blast Cleaning to Sa2.5	
Primer	Zinc Ethyl Silicate	50 – 60µm
Undercoat	Epoxy Glass flake (high build)	100 – 110 µm
Top Coat	Aromatic polyurethane TiO ₂ (rutile)	50 – 60µm
Total dry film thickness (DFT)		200 –230µm

7.04.04 Scheme-IV: For under prepared structures and not exposed to sunlight

Surface preparation	Mechanical chipping / Power tool cleaning St-3/Wire brushing St-2	
Primer	Self-priming epoxy mastic	100 – 150µm
Under coat	Self-priming epoxy mastic	100-110 µm
Top Coat	Aromatic polyurethane TiO ₂ (rutile)	50 – 60µm
Total dry film thickness (DFT)		250 –320µm

7.04.05 Scheme- V: For pipelines (above ground)

Surface preparation	Mechanical chipping / Power tool cleaning St-3/Wire brushing St-2	
Primer	Self-priming epoxy	100 – 150µm
Under coat	Epoxy Glass flake (high build)	100-110 µm
Top Coat	Aliphatic polyurethane TiO ₂ (rutile)	50 – 60µm
Total dry film thickness (DFT)		250 –320µm

7.04.06 Scheme-VI: Coating specifications for all other surfaces

Surface preparation	Power tool cleaning St-3/ Paint strippers	
Primer	Epoxy Zinc rich	50 – 60µm
Under coat	Epoxy glass flake	100-110µm
Top Coat	Aliphatic polyurethane TiO ₂ (rutile)	50 – 60µm
Total dry film thickness (DFT)		200–230µm

8.00.00 TESTING REQUIREMENTS





- 8.01.00 Measurement of dry film thickness
- Measurement of dry film thickness of coating: coating thickness shall be in the range of $\pm 20\%$ and as per SSPC PA 2.
- 8.01.01 Apparatus / instrument
- The instrument used for dry film thickness may be type 1 pull of gauges or type 2 electronic gauges.
- 8.01.02 Procedures
- a) Number of measurements

For 100 square feet (9.29 square meters), five (5) spots per test area (each spot is 3.8 cm) in diameter. Three gauge readings per spot (average becomes the spot measurement).
 - b) If the structure is less than 300 square feet, each 100 square feet should be measured.
 - c) If the structure is between 300 and 1000 sq ft, select 3 random 100 square feet test areas and measure.
 - d) For structure exceeding 1000 square feet, select 3 random 100 square feet testing areas for the first 1000 sq ft and select 1 random 100 square feet testing area for each additional 1000 square feet
 - e) Coating thickness tolerance: individual reading taken to get a representative measurement for the spot are unrestricted (usually low or high readings are discarded). Spot measurements (the average of 3 gauge readings) must be within 80% of the minimum thickness and 120% of the maximum thickness.
- Area measurement must be within specified range.
- 8.02.00 Electrical inspection (holiday) test
- 8.02.01 All the coated / lined pipes shall be tested with an approved high voltage holiday detector preferably equipped with an audio visual signaling device to indicate any faults, holes, breaks or conductive particles in the protective coating.
- 8.02.02 The applied output voltage of holiday detector shall have a spark discharge of thickness equal to at least twice the thickness of the coating to assure adequate inspection voltage and compensate for any variation in coating thickness. The electrode shall be passed over the coated surface at approximately half the spark discharge distance from the coated surface only one time at the rate of approximately 10 to 20m/min. The edge effect shall be ignored. Excessive voltage shall be avoided as it tends to induce holiday in the coated surface thereby giving erroneous readings.





**Tender Specification
for
FGD Package**

**NLC Tamil Nadu Power Ltd.
2x500 MW Project
Tuticorin, Tamil Nadu**

8.02.03 While selecting test voltages, consideration should be given to the tolerance on coating thickness and voltage should be selected on the basis of maximum coating thickness likely to be encountered during testing of a particular pipe.

The testing voltage shall be calculated by using following formula. (as per NACE 0274 : 2004)

Testing voltage $v=7900\sqrt{t\pm 10\%}$ where t=the average coating thickness, mm.

8.02.04 Any audio visual sound or spark leads to indicate pinhole, break or conductive particle.

8.03.00 Adhesion pull off test

After holiday the coated surface is subjected to adhesion pull off test as per ASTM D 4541.

8.03.01 Apparatus / instrument: adhesion tester consists of three basic components:

A hand wheel, a black column containing a dragging indicator pin and scale in the middle and a base containing three legs and a pulling "jaw" at the bottom and also dollies.

8.03.02 Prepare the test surface

Once test area is selected, test area shall be free of grease, oil, dirt, water. The area should be flat surfaces and large enough to accommodate the specified number of replicate test.

8.03.03 Prepare dolly (test pull stub)

The dolly is a round, two sided aluminium fixture. Both sides of the dolly looks same, however, one side sloped on top surface while flat on bottom surface. As the surface of the dolly is polished aluminium, roughen the same using a coarse sand paper.

8.03.04 Select an adhesive

Use araldite, a 100% solid epoxy adhesive. This adhesive requires at least 24 hours at room temperature to cure.

8.03.05 Attach the dolly to the surface

a) Using a wooden stick, apply an even layer of adhesive to the entire contact surface area of the dolly.

b) Carefully remove the excessive adhesive by using a cotton swab. Allow the adhesive to fully cure before performing the adhesion test.

c) Attach the dolly to the coated surface and gently push downward to





displace any excessive adhesive.

- d) Push the dolly inward against the surface, and then apply tape across the head of the dolly.

8.03.06 Adhesion test procedure

- a) Attach the adhesion tester to the dolly by rotating the hand wheel counter clockwise to lower the jaw of the device.
- b) Slide the jaw completely under the head of the dolly. Position the three legs of the instruments so that they are sitting flat on the coated surface.
- c) Slide the dragging indicator pin on the black column to zero by pushing it downward.
- d) Firmly hold the base of the instrument in one hand and rotate the hand wheel clockwise to raise the jaw of the device that is attached to the head of the dolly. The dragging indicator pin will move upward on the black column as the force is increased and will hold the reading. Apply the tension using a moderate speed. Continue to increase the tension on the head of the dolly until (a) the minimum psi/mpa/kg/cm² required by project specification is exceeded and the test is discontinued, (b) the maximum psi/mpa/kg/cm² of adhesion tester has been achieved and dolly is still attached, (c) the force applied by the adhesion tester causes the dolly to dislodge.
- e) Read the scale and record the adhesion value.

8.04.00 Coating repair

Defective coating shall be repaired in accordance with the following subsections.

8.04.01 Surface preparation

Accessible areas of pipe requiring coating repairs shall be cleaned to remove debris and damaged coating using surface grinders or other means. The adjacent coating shall be feathered by sanding, grinding or other method. Accumulated debris shall be removed by blowing with contaminant free air or wiping with clean rags.

8.04.02 Areas not accessible for coating repair such as interior surfaces of small diameter pipe shall be reprocessed and recoated.

8.04.03 Coating application

The coating system shall be applied to the prepared areas in accordance with procedure.

8.04.04 Repair inspection:





Repaired portion shall be electrically inspected using a holiday detector.

8.05.00 Welded field joints

8.05.01 Preparation

The weld joints shall be cleaned so as to be free from mud, oil, grease, welding flux, weld spatter and other foreign contaminants. The cleaned metal surfaces of the weld joint shall then be blasted or abraded using rotary abrading pads. The adjacent liquid epoxy / pu coating shall be feathered by abrading the coating surface for a distance of 25 mm.

8.05.02 Electrical inspection

After curing the coating system applied to the welding joints shall be holiday tested. Any holidays indicated by the detector shall be marked with chalk to identify the area of repair.

9.00.00 INFORMATION / DATA REQUIRED

The bidder shall submit complete list of paints and primers proposed, giving detail information, such as, chemical composition, drying time etc. And also unit rates for application of each type of paint along with supply shall be furnished.





Tender Specification
for
FGD Package

NLC Tamil Nadu Power Ltd.
2x500 MW Project
Tuticorin, Tamil Nadu

ANNEXURE-I
MARKET AVAILABLE COATING SYSTEMS AS PER SPECIFICATION

SI.No.	Specification	ASIAN PAINTS	BOMBAY PAINTS GRAUER & WEIL Paints	BERGER PAINTS	GRAND POLYCOTS	International Protective Coatings	KRISHNA CONCHEM
1.	Zinc Ethyl Silicate Primer	Apcosil 605 ZS	Zinc-o-sil 75	Zinc Anode 304	GP Prime 402	InterZinc 22	-
2.	Epoxy Zinc rich Primer	Apcodur CP 686			GP Prime 205	Inter Zinc 42	
3.	Self Priming Epoxy Mastic Paints	Rust-O-Cap	Penthdur Mastic 5527	Berger protecto Mastic	GP Prime guard 235	Interplus 256	-
4.	Epoxy Glass Flake Paint	Apcodur EP glass Flake	Pentadur Glass Flake 3580	Epilux Super Build ST Glass Flake Coating	GP SUPERGUA RD GLASS- FLAKE	Interzone 505	Karaiakote 100 S
5.	Aliphatic Polyurethane Paint	Apcothane CP 674	Pentathane 4512 (M)	Polyuretha ne Coating	GP Bond 141	Interthane990	-
6..	Aromatic Polyurethane Paint	---	--	--	GP COAT 131	---	



Development Consultants Pvt. Ltd.

Vol. II-A/Section-V
Protective Coating & Painting



**Tender Specification
for
FGD Package**

**NLC Tamil Nadu Power Ltd.
2x500 MW Project
Tuticorin, Tamil Nadu**

7.	Moisture Compatible anti Corrosion system			Epilux Durebild WSE Coating			Karaikote-6545
8.	Epoxy red oxide primer	AP CODUR Epoxy polyamide primer					
9.	Epoxy MIO Under coat	AP CODUR Epoxy MIO Under coat					
10.	Epoxy TiO2 Under coat	AP CODUR Epoxy 420HS					



Development Consultants Pvt. Ltd.

Vol. II-A/Section-V
Protective Coating & Painting

**2X500 MW NTPL TUTICORIN FGD****COMPRESSED AIR SYSTEM**

SPECIFICATION NO. PE-TS-483-555-A002

VOLUME : II B

SECTION : E / ANNEXURE-III

REV 00

DATE: FEB 2022

SHEET: 1 OF 1

ANNEXURE-III**MASTER DRAWING LIST WITH SCHEDULE OF
SUBMISSION**

MDL FOR CAS PACKAGE FOR TUTICORIN TPS – FGD

PROJECT	KAHALGAON TPS	PACKAGE-COMPRESSED AIR SYSTEM	NOA DATE		
"A" S NO	"B" VENDOR_DRG_NO.	"D" DRAWING TITLE	"E" PURPOSE	"G" NAME OF BOI	"H" SCHEDULED SUBMISSION (NO. OF WEEKS FROM LOA DATE/SCH PO DATE)(*)
1	PE-V0-483-555-A001	QUALITY PLAN OF AIR COMPRESSOR FOR FGD COMPRESSED AIR SYSTEM	A-CUST	CAS	2
2	PE-V0-483-555-A002	QUALITY PLAN OF AIR DRYING PLANT FOR FGD COMPRESSED AIR SYSTEM	A-CUST	CAS	2
3	PE-V0-483-555-A003	QUALITY PLAN OF AIR RECEIVER FOR FGD COMPRESSED AIR SYSTEM	A-CUST	CAS	3
4	PE-V0-483-555-A004	QUALITY PLAN OF MOTOR FOR FGD COMPRESSED AIR SYSTEM	A-CUST	CAS	3
5	PE-V0-483-555-A005	TDS OF AIR COMPRESSOR FOR FGD COMPRESSED AIR SYSTEM	A-CUST	CAS	2
6	PE-V0-483-555-A006	TDS OF AIR DRYING PLANT FOR FGD COMPRESSED AIR SYSTEM	A-CUST	CAS	2
7	PE-V0-483-555-A007	TDS & CHARACTERISTIC CURVES OF MOTOR FOR FGD COMPRESSED AIR SYSTEM	A-CUST	CAS	3
8	PE-V0-483-555-A008	TDS & GA OF VALVES FOR FGD COMPRESSED AIR SYSTEM	I-CUST	CAS	5
9	PE-V0-483-555-A010	TDS OF INSTRUMENTS FOR FGD COMPRESSED AIR SYSTEM	I-CUST	CAS	5
10	PE-V0-483-555-A011	GA DRAWING OF AIR COMPRESSOR FOR FGD COMPRESSED AIR SYSTEM	I-CUST	CAS	3
11	PE-V0-483-555-A012	GA DRAWING OF AIR DRYER FOR FGD COMPRESSED AIR SYSTEM	I-CUST	CAS	3
12	PE-V0-483-555-A013	GA DRAWING OF MOTOR FOR FGD COMPRESSED AIR SYSTEM	I-CUST	CAS	3
13	PE-V0-483-555-A014	GA DRAWING OF AIR RECEIVER FOR FGD COMPRESSED AIR SYSTEM	I-CUST	CAS	3
14	PE-V0-483-555-A015	COMPRESSOR HOUSE LAYOUT	A-CUST	CAS	4
15	PE-V0-483-555-A016	P & I DIAGRAM OF AIR COMPRESSOR FOR FGD COMPRESSED AIR SYSTEM	I-CUST	CAS	2
16	PE-V0-483-555-A017	P&I DIAGRAM OF AIR DRYER FOR FGD COMPRESSED AIR SYSTEM	I-CUST	CAS	2
17	PE-V0-483-555-A018	P&I DIAGRAM OF FGD COMPRESSED AIR SYSTEM WITHIN COMPRESSOR HOUSE	A-CUST	CAS	3
18	PE-V0-483-555-A019	OPERATION & CONTROL PHILOSOPHY OF FGD COMPRESSED AIR SYSTEM	A-CUST	CAS	3
19	PE-V0-483-555-A020	ELECTRICAL & INTERNAL WIRING DIAGRAM FOR COMPRESSOR PANEL FOR FGD COMPRESSED AIR SYSTEM.	I-CUST	CAS	2
20	PE-V0-483-555-A021	ELECTRICAL FEEDER LIST FOR FGD COMPRESSED AIR SYSTEM	I-G-P	CAS	3
21	PE-V0-483-555-A022	CONTROL CABLE SCHEDULE FOR FGD COMPRESSED AIR SYSTEM	I-G-P	CAS	5
22	PE-V0-483-555-A023	PG TEST PROCEDURE FOR FGD COMPRESSED AIR SYSTEM	I-CUST	CAS	7
23	PE-V0-483-555-A024	O&M MANUAL-FGD COMP AIR SYSTEM	I-CUST	CAS	12
24	PE-V0-483-555-A029	SUB-VENDOR LIST WITH INSPECTION CATEGORISATION PLAN FOR FGD COMPRESSED AIR SYSTEM	A-CUST	CAS	1

**2X500 MW NTPL TUTICORIN FGD****COMPRESSED AIR SYSTEM**

SPECIFICATION NO. PE-TS-483-555-A002

VOLUME : II B

SECTION : E / ANNEXURE-IV

REV 00

DATE: FEB 2022

SHEET: 1 OF 1

ANNEXURE-IV

SITE STORAGE AND PRESERVATION

SITE STORAGE AND PRESERVATION GUIDELINES FOR MECHNANICAL BOPs

(Doc No: PE-DC-SSG-A001 REV.00)



PROJECT ENGINEERING MANAGEMENT, POWER SECTOR
BHARAT HEAVY ELECTRICALS LIMITED-NOIDA

CONTENT

- 1 SCOPE OF THE DOCUMENT
- 2 PURPOSE OF STORAGE & PRESERVATION
- 3 MEASURES TO BE TAKEN FOR STORAGE AND PRESERVATION
 - a) GENERAL STORAGE REQUIREMENTS
 - b) GENERAL PRESERVATION REQUIREMENTS
 - c) GENERAL INSPECTION REQUIREMENTS
- 4 TYPE OF STORAGE FOR VARIOUS EQUIPMENT
5. CONCLUSION
6. STACKING ARRANGEMENT FOR PLATES AND STRUCTURAL STEEL

1. SCOPE OF THE DOCUMENT

This guideline is prepared in intent to provide proper site storage and preservation of the Mechanical, Electrical and C & I items / equipment supplied under various bought out packages/items. This storage procedure shall be followed at different power plant sites by concerned agency for storage and preservation from the date of equipment received at site until the same are erected and handed over to the customer.

2. PURPOSE OF STORAGE & PRESERVATION

Many of the items may be required to be kept in stores for long period. It shall therefore be essential that proper methods of storage and preservation be applied so that items do not deteriorate, loose some of their properties and become unusable due to atmospheric conditions and biological elements.

3. MEASURES TO BE TAKEN FOR STORAGE, HANDLING & PRESERVATION

a) GENERAL STORAGE REQUIREMENTS

1. To the extent feasible, materials should be stored near the point of erection. The storage areas should have adequate unloading and handling facilities with adequate passage space for movement of material handling equipment such as cranes, fork lift trucks, etc. The storage of materials shall be properly planned to minimise time loss during retrieval of items required for erection.
2. The outdoor storage areas as well as semi-closed stores shall be provided with adequate drainage facilities to prevent water logging. Adequacy of these facilities shall be checked prior to monsoon.
3. The storage sheds shall be built in conformity with fire safety requirements. The stores shall be provided with adequate lights and fire extinguishers. 'No smoking' signs shall be placed at strategic locations. Safety precautions shall be strictly enforced.
4. Adequate lighting facility shall be provided in storage areas and storage sheds and security personnel positioned to ensure enforcement of security measures to prevent theft and loss of materials.
5. Adequate number of competent stores personnel and security staff shall be deployed to efficiently store and maintain the equipment / material.
7. The equipment shall be stored in an orderly manner, preserving their identification slips, tags and instruction booklets, etc., required during erection. The storage of materials shall be equipment-wise. Loose parts shall be stored in sheds on racks,

preserving the identification marks and tags in good condition. The group codes shall be displayed on the racks

6. At no time shall any materials be stored directly on ground. All materials shall be stored minimum 200 mm above the ground preferably on wooden sleepers

b) GENERAL PRESERVATION REQUIREMENTS

1. All special measures to prevent corrosion shall be taken like keeping material in dry condition, avoiding the equipment coming in contact with corrosive fluid like water, acid etc.
2. Materials which carry protective coating shall not be wrapped in paper, cloth, etc., as these are liable to absorb and retain moisture. The material shall be inspected and in case of signs of wear or damages to protective coating, that portion shall be cleaned with approved solution and coated with an approved protective paint. Complete record of all such observations and protective measures taken shall be maintained.
3. Generally equipment supplied at site are properly greased or rust protective oil is applied on machined/ fabricated components. However periodic inspection shall be carried out to ensure that protection offered is intact.
4. While handling the equipment, no dragging on the ground is permitted. Avoid using wire rope for lifting coated components. Use polyester slings (if possible) otherwise protective material (e.g. clothes, wood block etc.) should be used while handling the components with rope / slings
5. For Equipment supplied with finished paint, touch paint shall be done in case any surface paint gets peeled off during handling. Otherwise such surfaces shall necessarily be wrapped with polythene to avoid any corrosion. Further for equipment wherein finish coat is to be applied at site, site to ensure that equipment is received with primer coat applied.
6. It shall be ensured by periodic inspection that plastic inserts are intact in tapped holes, wherever applicable.
7. Pipes shall be blown with air periodically and it shall be ensured that there is no obstruction.
8. Silica gel or approved equivalent moisture absorbing material in small cotton bags shall be placed and tied at various points on the equipment, wherever necessary.
9. Heavy rotating parts in assembled conditions shall be periodically rotated to prevent corrosion/jamming due to prolonged storage.

10. All the electrical equipment such as motors, generators, etc. shall be tested for insulation resistance at least once in three months and a record of such measured insulation values shall be maintained.
11. Following preservatives/preservation methods can be used depending upon type of equipment
 - a. Rust preventive fluid (RPF)
 - b. Rust protective paints
 - c. Tarpaulin covers, in case of outdoor storage
 - d. De-oxy aluminate for weld-ments

c) GENERAL INSPECTION REQUIREMENTS

1. Period inspection of materials with specific reference to –
 - Ingress of moisture and corrosion damages.
 - Damage to protective coating.
 - Open ends in pipes, vessels and equipment -
 - In case any open ends are noticed, same shall be capped.
2. Any damages to equipment / materials.
 - In case of any damages, these shall be promptly notified and in all cases, the repairs / rectification shall be carried out.
 - Any items found damaged or not suitable as per project requirements shall be removed from site. If required to store temporarily, they shall be clearly marked and stored separately to prevent any inadvertent use.

4. TYPE OF STORAGE FOR VARIOUS EQUIPMENT

The types of storage are broadly classified under the following heads:

i **Closed storage with dry and dust free atmosphere. (C)**

The closed shed can be constructed by using cold-rolled / tubular components for structure and corrugated asbestos sheets / galvanised iron sheets for roofing. Brick walls / asbestos sheets can be used to cover all the sides. The floor of the shed can be finished with plain cement concrete suitably glazed. The shed shall be provided with proper ventilation and illumination.



ii **Semi-closed storage. (S)**

The semi closed shed can be constructed by using cold-rolled / tubular components for structure and corrugated / asbestos sheets for roofing. The floor shall be brick paved. If required a small portion of sides can be covered to protect components from rainwater splashing onto the components.





iii Open storage (O)

The open yard shall be levelled, well consolidated to achieve raised ground with the provision of feeder roads for crane approach along with access roads running all sides. One part of the open yard shall be stone pitched, levelled and consolidated with raised ground suitable for storing / stacking heavier and critical components with due space to handle them by cranes etc . Adequate number of sleepers, concrete block etc. to be provided to make raised platforms to stack critical materials.

A separate yard to be identified as “scrap yard” slightly away from main open yard to store wooden/steel scraps, which are to be disposed off. This is required to avoid mix up with regular components as well as to avoid fire hazard.

Some of the components, which are having both machined & un-machined surfaces and are bulky, shall be stored in open storage area on a raised ground and suitably covered with water proof / fire retardant tarpaulin.



714945/2022/PS-PEM-MAX

The equipment listed below shall be stored and inspected as per requirement mentioned in the table below.

Sl. No.	Description of the equipment	Type of Storage	Check for	Remarks
Raw material /mechanical items like pipes, plates, structure sections etc.)				
1.	Steel pipes (lined/unlined)	S	Damage , paint, corrosion, rubber lining peeling	Provide end cap
2.	MS Plates	S	Damage, paint, corrosion	
3.	SS Plates	S	Damage	
4.	Non-metallic pipes	S	Damage, cracks	Provide end cap
5.	Stainless steel pipes	S	Damage ,	Provide end cap
6.	MS sections, beams	S	Damage, paint, corrosion	
7.	Cable trays	S	Damage, condition of preservations	
8.	Insulation sheets	S	Damage	
9.	Insulation	C	Damage, packing	
10.	Hangers Rods	S	Damage, paint, packing	
11.	Tubes	S	Damage, paint , packing	Provide end cap
12.	Hume pipes	O	Damage	
13.	Castings	O	Damage, paint, corrosion	
Fabricated mechanical items (pressure vessels, tanks etc.)				
14.	Pressure vessels (unlined)	O	Damage, paint, corrosion,	Covered nozzles
15.	Atmospheric storage tanks (unlined)	O	Damage, paint, corrosion	Covered nozzles

Sl. No.	Description of the equipment	Type of Storage	Check for	Remarks
16.	Pressure vessels (lined)	S	Damage, paint, corrosion, rubber lining	
17.	Atmospheric storage tanks(lined)	S	Damage, paint, corrosion, rubber lining	
18.	Support structures	O	Damage , paint, corrosion	
19.	Flanges	C	Damage , paint, corrosion	
20.	Fabricated pipes	S	Damage , paint, corrosion	Provide end cap
21.	Vessels internals	C	Damage , paint, corrosion ,packing	
22.	Grills	S	Damage , paint, corrosion	
23.	Angles	S	Damage , paint, corrosion	
24.	Bridge mechanism/clarifier mechanism	O	Damage , paint, corrosion	
25.	Cranes, rails	S	Damage , paint, corrosion	
26.	Stair cases	O	Damage , paint, corrosion	
27.	Ladders/handrails	O	Damage , paint, corrosion	
28.	Fabricated ducts	S	Damage , paint, corrosion	
29.	Isolation Gates	O	Damage , paint, corrosion	
30.	Fabricated boxes/panels	S	Damage , paint, corrosion	
Mechanical components like valves, fittings, cables glands, spares etc.)				
31.	Valves	S	Damage , packing	

Sl. No.	Description of the equipment	Type of Storage	Check for	Remarks
32.	Fittings	S	Damage , packing	Provide end cap
33.	Cable glands	C	Damage , packing	
34.	Tools & tackles	C	Damage , packing	
35.	Nut , bolts, washers,	C	Damage , packing	
36.	Gasket & Packings	C	Damage , packing	
37.	Copper tubes	C	Damage , packing, corrosion	Provide end cap
38.	SS tubing	C	Damage , packing	Provide end cap
Rotating assemblies (pumps, blowers, stirrers, fans, compressors etc.)				
39.	Pumps	S	Damage , packing, corrosion	Shaft rotation
40.	Blowers/Compressors	S	Damage , packing, corrosion	Shaft rotation
41.	Agitators/stirrers/radial launders	C	Damage , packing, corrosion	Shaft rotation
42.	Rollers for chlorine tonner mounting	C	Damage , packing, corrosion	
43.	Centrifuge	S	Damage , packing,	
44.	Gear box	C	Damage , packing, corrosion	
45.	Bearings	C	Damage , packing, corrosion	
46.	Fans	S	Damage , packing, corrosion	
47.	Dosing skids	S	Damage , packing, corrosion	
48.	Pump assemblies	S	Damage , packing, corrosion	
49.	Air washers(INTERNALS)	S	Damage , packing	
50.	Air conditioners (split)	C	Damage , packing	

Sl. No.	Description of the equipment	Type of Storage	Check for	Remarks
51.	Elevators(CONTAINERIZED)	O	Damage , packing, corrosion	
52.	Chillers/VA machines	S	Damage , packing	
53.	Air handling Unit/Package unit	S	Damage , packing	
54.	Chlorinators & Evaporators	C	Damage , packing	
55.	Ejectors	C	Damage , packing	
56.	Electrolyser	C	Damage , packing	
Miscellaneous items like chain pulley blocks, hoists etc.				
57.	Chain pulley blocks	S	Damage, Packing	
58.	Electric hoists	S	Damage, Packing	
59.	Fire extinguishers	C	Damage, expiry date	
60.	Fork Lift Truck	S	Damage, Packing	
61.	Hydraulic Mobile Crane	O	Damage, Packing	
62.	Mobile Pick Up & Carry Crane	O	Damage, Packing	
63.	Motor boats	O	Damage, Packing	
64.	Safety showers	S	Damage, Packing	
65.	Diffusers/dampers	S	Damage, Packing	
Chemicals and consumables (acid, alkali, paints, oils, reagents and special chemicals)				
66.	Hydro Chloric Acid (HCl)	Store in canes/ storage tank in dyke area	Date of production/ leakage/fumes	hazardous chemical
67.	Sulphuric acid (H ₂ SO ₄)	Store in canes/ storage tank in dyke area	Date of production/ leakage/fumes	hazardous chemical

Sl. No.	Description of the equipment	Type of Storage	Check for	Remarks
68.	Sodium hydroxide (NaOH)	Store in canes/ storage tank in dyke area	Date of production/ leakage/ fumes/ breather	hazardous chemical ,breather to be checked for air ingress
69.	Sodium hypo chlorite	To be stored under shed	Date of production/ leakage/ fumes	hazardous chemical ,self-life normally 15-30 days after which strength of chemical decays
70.	Ammonia	S	Date of production/ leakage/ fumes	Store in closed storage tanks, hazardous chemical
71.	CW treatment chemicals	S	Date of production , Self-life	Store in closed canes
72.	RO/UF cleaning chemicals	S	Date of production , Self-life	Store in closed canes
73.	Lime	C	Damage to packing , seepage	Prevent moisture, rain
74.	Alum bricks	C	Damage to packing	Prevent moisture, rain
75.	Poly electrolyte	S		Store in closed storage tanks
76.	Laboratory chemicals(powder)	C	Damage, Packing self- life	
77.	Laboratory chemicals(liquid)	C	Damage, Packing self- life	
78.	Lubrication oils	C	Leakage	
79.	Paints	S	Leakage ,air tightness	
80.	Sand	O	Damage of packing	No hooks
81.	Salt (NaCl)	C	Damage of packing, water ingress	Prevent moisture, rain
82.	Anthracite	S	Damage of packing	
83.	Activated carbon	S	Damage of packing	

Sl. No.	Description of the equipment	Type of Storage	Check for	Remarks
84.	Thermal insulation	S	Damage of packing	
85.	Cement	C	Damage of packing	Prevent moisture, rain
86.	Gravels	O	Damage of packing	
87.	ION exchange resins	C	Damage , packing	Refer manufacturer guidelines
88.	RO membranes	C	Damage , packing	Refer manufacturer guidelines
89.	UF membranes	C	Damage , packing	Refer manufacturer guidelines
90.	Cleaning chemicals	C	Damage , packing	Refer manufacturer guidelines
91.	Chemicals for analysers/calibration	C	Damage , packing	Refer manufacturer guidelines
Electrical and C & I items (motors, cables etc.)				
92.	Motors	C	Damage , packing	
93.	Cable drums	O	Damage	
94.	Control Panel /control desk, UPS ,JB	S	Damage, Packing	
95.	Instruments(gauges/analysers)	C	Damage	
Special items		As per Manufacturer's item, like Hydrogen cylinders, Ozonator, Analyser, Chlorine dioxide generators etc.		

5. CONCLUSION

Concerned storage agency at site should make sure that loss in equipment performance and wear & tear are minimised through proper storage and preservation. The above are broad guidelines and cover major equipment / materials. However specific storage practices shall be followed as per manufacturer recommendation. All the necessary measures even in addition to the ones mentioned above, if found necessary, should be taken to achieve the objective.

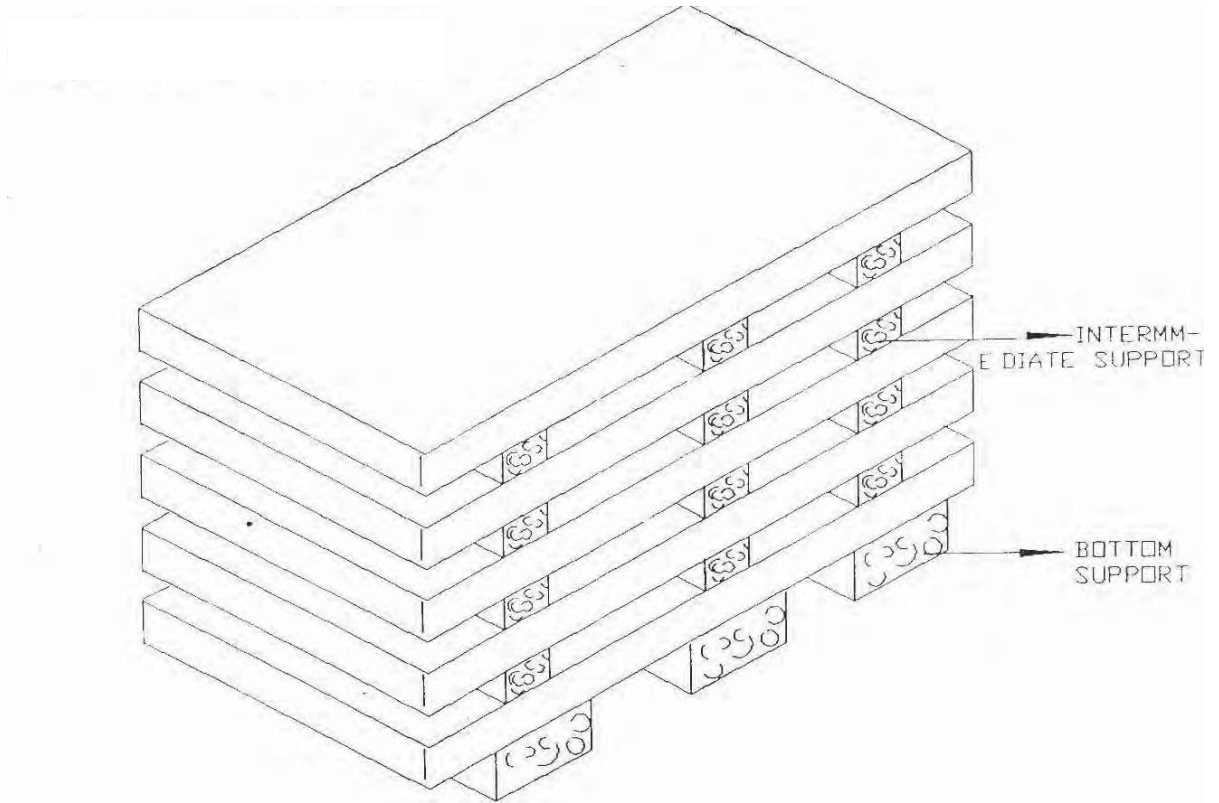

Figure – 1 – PLATE STACKING ARRANGEMENT

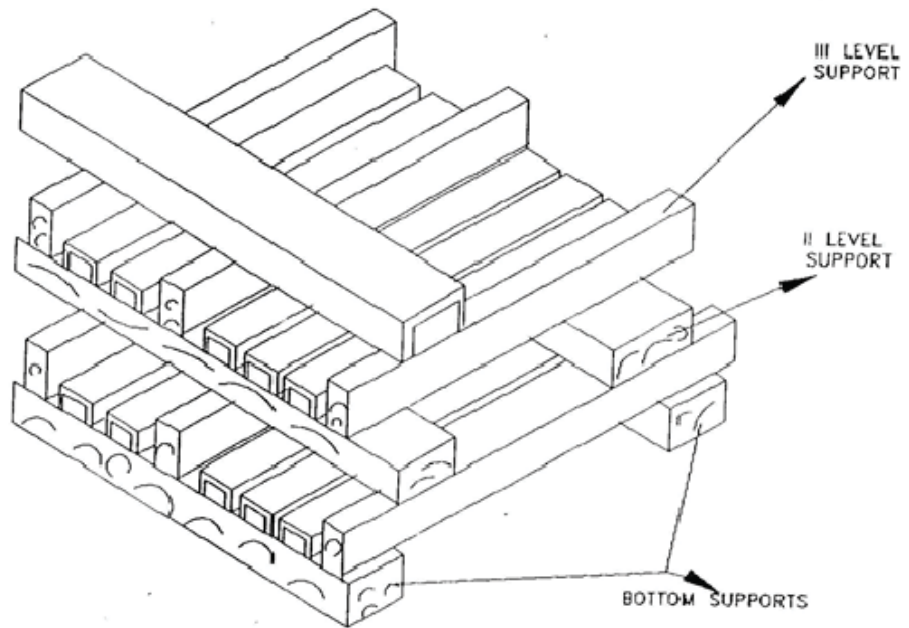



Figure – 2 – STRUCTURAL STEEL STACKING ARRANGEMENT

	2X500 MW NTPL TUTICORIN FGD COMPRESSED AIR SYSTEM	SPECIFICATION No: PE-TS-483-555-A002	
		VOLUME : II B	
		SECTION : E / ANNEXURE-V	
		REV 00	DATE: FEB 2022
		SHEET: 1 OF 1	

**ANNEXURE-V
PACKING PROCEDURE**



CORPORATE STANDARD

AA0490010

Rev. No. 02

PAGE 1 of 24

DOMESTIC PACKING

COMMON GUIDELINES

1 GENERAL:

This standard lays down packing instructions for domestic packing of Components/ Assemblies/ Equipment to be despatched against Customer's contracts, for which there are no special instructions issued by the Engineering Departments. For Seaworthy Packing refer standard AA0490004 wherever applicable.

The Components/Assemblies need to be packed suitably to avoid physical damage & corrosion during transit & storage. For specific applications the concerned engineering department shall issue a product standard. Reference of this product standard, must appear in the Shipping list/Packing List.

2 SCOPE:

This procedure gives minimum guidelines to be complied with for domestic packing of Components /Assemblies/ Equipment. This domestic packing shall be suitable for different handling operations and for the adverse conditions during transportation and during indoor / outdoor storage of materials.

3 WOOD SPECIFICATION

Based on availability, the wood shall conform to specification AA51401 or AA51402.

4 TYPES OF PACKING:

The following 5 types of packing have been standardized for packing of General Components/ Assemblies.

- 1) 'OP' - Open Type.
- 2) 'PP' - Partially Packed.
- 3) 'CP' – Crate/Box Packing - Components/Equipment requiring physical protection.
- 4) 'CQ' - Case Packing – Machined components-Small & Medium Components/ Assemblies/ Equipment which require corrosion & physical protection.
- 5) 'CR' - Case Packing – Electrical/Electronic Components/ Assemblies, which require special packing viz. Water Proof, Shock Proof etc...

5 DESCRIPTION OF TYPES OF PACKING:

The various types of packing, as standardized above, are described below.

5.1 'OP' - Open Type

In case, of components which are not affected by water & dust and do not require special protection, are generally not machined, shall be sent as open packages. However, these components may be sent in crates, wherever necessary.

5.2 'PP' - Partially Packed

Components which need special protection at selected portions only shall be despatched partially packed. Machined surfaces should not be allowed to come directly in contact with the wood. Such surfaces should be protected with 100GSM(Colourless) Multi Layered Cross Laminated Polyethylene

Revisions:

APPROVED:

PROCEDURAL GUIDELINES COMMITTEE –
PGC (Packing)

Rev. No. 02

Amd. No.

Reaffirmed

Prepared

Issued

Dt. of 1st Issue

Dt: 28-08-2018

Dt:

Year:

HPBP, Trichy

Corp. R&D

31-05-2018

AA0490010

Rev. No. 02

PAGE 2 of 24

CORPORATE STANDARD

Film to Specification No. AA51420. All sharp corners and edges shall be protected by rubber mats to prevent damage to the polyethylene film

5.3 'CP' - Crate Packing

Assemblies/Components which need only physical protection from the point of view of handling shall be despatched duly packed in crates.

5.4 'CQ' - Case Packing - Machined Components/Assemblies/Equipment

Small and medium sized components/assemblies/equipment due to size/weight and to avoid handling and pilferage problems shall be packed in Case/Containers. Wherever required adequate quantity of silica gel to AA55619 or VCI Powder/Tablets, packed in thin muslin cloth cotton bags shall be suitably placed. Small machines/components of less weight shall be provided with suitable cushioning by Rubberised coir. The components inside the case shall be entirely covered with 100GSM(Colourless) Multi Layered Cross Laminated Polyethylene Film Specification No. AA51420, wherever required. This may be prescribed for electronic parts/critical machined components/surfaces.

For mechanical product like valves where motors are separately securely wrapped in polyethylene, the requirement of individual component wrapping shall be exempted.

5.5 'CR' - Case Packing - Electrical & Electronic Components/Assemblies

Delicate components likely to be damaged e.g. Gauges, Instruments etc. are to be wrapped in waxed paper or polyethylene air bubble film and packed in cartons. Adequate quantity of Silica gel to AA55619 packed in cotton bags of 100grams each are to be suitably placed in the cartons. The cartons shall be entirely covered with 100GSM(Colourless) Multi Layered Cross Laminated Polyethylene Film Specification No. AA51420 before being packed in the cases. VCI Powder/Tablets can be used as an alternative to Silica Gel to AA55619.

Empty space in the cartons shall be filled with rubberized coir to get proper cushioning effect. The cartons shall be manufactured from corrugated Fiber Board, meeting requirements of AA51414.

6 PREPARATION OF PACKING CASES**6.1 DIMENSIONS:**

- a) Thickness of planks for Front, rear, top and bottom sides and binding, jointing battens shall be 25/20mm +2/-3 mm as per applicable drawings of the respective units.
- b) Width of all planks including the tongue shall be more than 125mm and after planing it shall be minimum 100mm.
- c) Minimum number of planks shall be used for a shook.
- d) Horizontal, vertical, diagonal planks shall be given for binding (number of such planks depend on the dimension of panel).
- e) Width of binding planks shall be minimum 100mm.
- f) Distance between any 2 binding planks shall be less than 750mm.
- g) diagonal planks shall be used in between vertical binding planks when distance between inner to inner of vertical planks is more than 750mm
- h) Distance of the outer edges of these planks from the edge of case shall be less than 250mm.
- i) Diagonal planks are not required for top planks and width side, if the width of pallet is less than 750mm.

6.2 JOINTING OF PLANKS

Single length planks shall be used for cubicles whose overall length is less than 2400mm. For cubicles of length more than 2400mm, jointing is permitted. The jointing shall be done with one single or maximum of 2 planks of wood same as other planks of width 250 mm (minimum) with two rows of nails on either side of the joint in zigzag manner. From the joint along height side, it shall be of lap joint with overlap of at least the width of plank.

	CORPORATE STANDARD	AA0490010
		Rev. No. 02
		PAGE 3 of 24

6.3 TONGUE AND GROOVE JOINTS

Two consecutive planks shall be joined by tongue and groove joint. Depth of tongue shall be 12+1 mm, thickness of tongue shall be 8 +1 mm. The groove dimensions shall be such that the tongue fits tightly into the groove to make a good joint. This type of joint can be done based on the product requirement wherever required.

6.4 PERMISSIBLE DEFECTS

Wood shall be free from knots, bows, visible sign of infection and any kind of decay caused by insects, fungus, etc.

End splits: Longest end splits at each end shall be measured and lengths added together. The added length shall not exceed 60mm per meter run of shooks. Wood pins shall be used to prevent further development of split.

Surface cracks: Surface cracks with a maximum depth of 3mm are permissible. A continuous crack of any depth all along the length is not allowed.

6.5 OTHER MATERIALS

6.5.1 NAILS

The dia. of the nails shall be 3.15mm. The length of the nails shall be 65mm wherever two planks of 25mm thickness are joined and 75mm wherever a 25mm planks is joined to a 50mm plank.

6.5.2 BLUE NAILS

These are used for nailing bituminized Kraft paper/hessian cloth to the planks. The length of the nails shall be 16mm.

6.5.3 HOOP IRON STRIPS

These are used for strapping the boxes. The width of the strips shall be 19+1mm and thickness 0.6+0.01mm. The material shall be free from rust. If sufficient nailing is done for bigger boxes, strapping need not be done.

6.5.4 CLIPS

These shall be used for strapping the hoop iron strips on the boxes.

6.5.5 BRACKETS

These brackets are used for nailing to the corners of cubicle boxes. The brackets shall be of mild steel of thickness min 2mm and width 25+1mm. The brackets shall be of "L" shape, the length of each side being 100+2mm. Two holes shall be provided towards the end of each side for screwing /nailing.

6.5.6 FASTENERS

Bolts, double nuts, spring washers will have to be used for packing of some special items like transformers, reactors, breakers, etc., to hold the job to the bottom plank of the box. The bolts, nuts, washers will be provided by the vendor. Drilling of holes will have to be done using contractor's tools.

6.5.7 MULTI LAYERED CROSS LAMINATED POLYTHELENE FILM

100GSM (Colourless) Multi Layered Cross Laminated Polythelene Film Specification No: AA51420 are used to make covers to the jobs individually. The cross lamination gives qualities of extra toughness, together with flexibility and lightness coupled with good weather resistance to ultra violet rays.

6.5.8 RUBBERISED COIR:

The rubberized coir is used as cushioning material. For the packing of loose items, items are to be arrested by using rubberized coir. For the packing of cubicles rubberized coir of thickness 25mm and width 75mm shall be used.

6.5.9 FOAM RUBBER / 'U' FOAM:

This is used for covering the delicate items. This material is provided by the vendor.

AA0490010

Rev. No. 02

PAGE 4 of 24

CORPORATE STANDARD**6.5.10 MARKING PLATE:**

This shall be of anodized aluminium sheet. Size of the marking plate shall be maintained minimum of size as per the details specified in the Figure 4.

6.5.11 PACKING SLIP HOLDER:

This shall be of galvanized iron tinned sheet /Aluminium sheet

6.5.12 SILICA GEL:

This shall be of indicating type to conform to IS: 3401/AA55619. Silical gel shall be used for such products only where moisture needs to be avoided.

6.5.13 COTTON BAGS:

These are used for holding silica gel. The bags shall have the following matter indicated on them:

BHEL-UNIT NAME	PLACE-PINCODE
SILICA GEL	INDICATING TYPE
BLUE :	ACTIVE
ROSE :	REDUCED ACTIVITY
WHITE :	NO ACTIVITY. TO BE REPLACED WITH FRESH SILICA GEL

6.5.14 COTTON/ PLASTIC TAPE:

This is used for tying small items. And also to prevent vibrations of moving parts within the cubicles.

6.5.15 MARKING INK:

The ink used normally is black in color. In some special cases other color also will have to be used. The ink shall be non-fading/indelible and non-washable by water.

6.5.16 POLYETHYLENE BAGS:

These are to be used for keeping the Packing slips. The bag shall be of size 70mm X 100mm (minimum).

6.5.17 Hessian cloth, twine thread, paint will have to be used in packing certain items.**6.5.18 Mechanical Latching clamps:**

For CLW Railway panels and similar Panels self-locking clamps can also be used on need basis in conjunction with or apart from regular bolt and nut fixing arrangement. For reusable boxes, these clamps provide easy locking and unlocking arrangement. These clamps will be made available from BHEL in some cases.

6.5.19 STICKERS

The following stickers to be put by the vendor on cubicles/Boxes after packing.

- 1) Case No sticker: 2 nos. Size 25.Cm x 0.45Cm
- 2) BHEL Monogram sticker: 1 no. Size 1.75Cm x 2.3Cm
- 3) Address sticker: 2 nos. Size 3.8Cm x 3.0Cm
- 4) Direction sticker "Front" & "Back" - 4 nos. Size 2.0Cm x 0.75Cm
- 5) Chain Mark Sticker: 4 Nos. Size – 3.0Cm x 0.75Cm
- 6) "Fragile" sticker: 2 Nos. Size. 2.1Cm x 1.5Cm
- 7) "DO NOT STACK" sticker - 2 Nos. Size 3.0Cm x 2.2Cm

	<h2 style="margin: 0;">CORPORATE STANDARD</h2>	AA0490010
		Rev. No. 02
		PAGE 5 of 24

In place of stickers, writing all the details legibly with paint shall be allowed & respective units may take decision accordingly.

7 PACKING OF CUBICLES:

- 7.1 The packing is to be done as per clause 5 in all respects.
- 7.2 The cubicles are already fixed on wooden pallets. Hence the contractor need not arrange the bottom pallets normally.
- 7.3 The cubicles will be of different sizes both width wise and lengthwise. The cubicles may be made up of single suite, 2 Suite, 3 Suite, 4 Suite, etc., The width of the cubicles generally varies from 400 mm to 1650mm. The length of the cubicle, generally varies from 1500 mm to 4800 mm. The height is normally 2430 mm. In some cases, the height may be less/more.

7.4 MULTI LAYER CROSS LAMINATED POLY FILM

The inner surface of 4 sides of shoo's shall be nailed with Multi-layer cross laminated poly film (as per 6.5.7) using blue nails (as per 6.5.2) wherever 2 pieces of Cross laminated poly film are used, the joint shall have an overlap of minimum 20mm.

The inner surface of top cover shall be nailed with Multi-layer cross laminated poly film (as per 6.5.7). This sheet shall project outside on 4 sides by at least 100mm and shall be nailed properly on sides. Joining of sheets should have overlap of minimum 20mm.

The cubicles shall be covered with Multi-layer cross laminated poly film (as per 6.5.7).

7.5 SILICA GEL:

Silica gel (as per 6.5.12) packed in cotton bags shall be kept at different places inside the cubicle as per BHEL-Unit directions. Each suit of cubicle shall be provided with 1 kg of Silica gel (for a 4 suit cubicle 4 kgs of Silica Gel to be used. The bag containing silica gel to be as per 6.5.13).

7.6 LOOSE PARTS:

Any loose parts in the cubicles shall be tied using cotton/ plastic tape. Wooden battens shall be provided wherever necessary.

7.7 WOODEN BATTENS:

In case of cubicle which are not rectangular in shape like control desks, sufficient number of wooden rafters/battens of proper size shall be provided to give strength to the package.

7.8 RUBBERISED COIR:

Gap between the cubicle and the case shall be filled with rubberized coir (as per 6.5.8) with distance between consecutive layers less than 500mm.

7.9 CLAMPING:

Packing shall be bound at edges by nailing M.S. Clamps / Brackets (as per 6.5.5). Each vertical edge shall have minimum 3 clamps. Top horizontal edges will have one clamp for every meter length of package. However, minimum 4 clamps shall be nailed at the top for any cubicle.

7.10 PACKING SLIP:

Packing slip kept in the polyethylene bag (As per 6.5.16) shall be placed in the box at appropriate place. In addition, one more packing slip covered in polyethylene cover and packing slip holder (as per 6.5.11) shall be nailed to front / rear of case.

7.11 MARKING PLATE:

One no. (As per 6.5.10) shall be nailed to the front side of the case.

7.12 CASE MOUNTING:

After complete packing, stencil marking of various details and marking of symbols shall be done as per BHEL instructions using indelible / non washable marking ink.

AA0490010

Rev. No. 02

PAGE 6 of 24

CORPORATE STANDARD**7.13 Different types (Typical) of Cubicles with sizes for Packing**

1. Single suite cubicle - 900 x 950 x2500
2. Two suite cubicle - 1650 x 950 x 2500
3. Three suite cubicle - 2400 x 950 x2500
4. Four suite cubicle - 3150 x 950 x 2500
5. Regulation cub - 1300 x 1350 x 2500
6. Thy cub - 2870 x 1350 x 2500
7. VFD Cub - 3800 x 1550 x 2500

7.14 PACKING OF CUBICLES FOR EXPORT

Refer Corporate Standard AA0490009.

8 PACKING OF LOOSE ITEMS/SPARES

- 1) Shape of cases shall be square, rectangular with single gabled roof or with double gabled roof depending on the nature of the job to be packed. Construction shall be as per drawings enclosed. Only gable will be additional as required.
- 2) Wood shall conform to specification AA51401 or AA51402 with Tongue and Groove joint as per clause 6.3.
- 3) Width of planks shall be at least 100 mm. Width of binding planks (battens) shall be at least 75mm.
- 4) External surface of planks on front and rear shall be plane 100% (except bottom plank).
- 5) Inner surfaces of all 6 sides shall be lined with Multi Layered Cross Laminated Polythelene Film (as per clause 6.5.7) using blue nails.
- 6) Rubberized coir of minimum 25mm thickness and 100 mm width shall be nailed to inner surfaces of bottom and 4 sides of box.
- 7) Internal packing: Items that go into the box shall be packed using 100GSM, (Colourless) Multi Layered Cross Laminated Polyethylene Film Specification No: AA51420. Any space left between the job and the sides and the top of the box shall be filled with rubberized coir to get proper cushioning effect.
- 8) Certain items like transformers, reactors, breakers, etc., shall be bolted to the bottom of the box using bolts, nuts and washers.
- 9) Silica gel as per clause 6.5.12 held in cotton bags as per clause 6.5.13 shall be kept at proper places in the box.
- 10) Packing slip kept in polyethylene bag (clause 6.5.16) shall be placed in the box.
- 11) Marking plate as per clause 6.5.10 shall be nailed to side of the box.
- 12) Two numbers of hoop iron strips as per clause 6.5.3 shall be strapped tightly on the case using clips.
- 13) Stencil marking of various details and marking of various symbols shall be done as per BHEL instructions using indelible/non-washable marking ink.
- 14) Loose items to be kept inside the cubicle
 - The components which are removed from cubicle for shipping purpose only, such as meters shall be kept inside the cubicle individually, kept in wooden box and tied firmly in bottom of Cubicle.
 - Other items which are given loose in addition to cubicle shall be packed in separate boxes.

9 BOX SIZES**9.1 BOX SIZES**



CORPORATE STANDARD

AA0490010

Rev. No. 02

PAGE 7 of 24

Table 1 – SPARES WOODEN BOX DETAILS

SNO	BOX TYPE	BOX SIZE (in mm)	BOX Wt (in KG)	Carrying Capacity
1	A	800 X 200 X 200	15	
2	B	1500 X 200 X 200	22	
3	C	2000 X 200 X 200	27	
4	D	1100 X 200 X 200	15	
5	E	200 X 200 X 200	5	
6	F	320 X 250 X 260	13	
7	G	320 X 250 X 430	16	
8	H	430 X 370 X 430	23	
9	I	1100 X 400 X 400	45	
10	J	1500 X 500 X 400	65	
11	K	2000 X 500 X 400	93	
12	L	2500 X 500 X 400	88	
13	M	900 X 600 X 600	100	
14	N	3000 X 400 X 400	60	
15	P	600 X 500 X 400	35	
16	Q	710 X 630 X 600	90	
17	R	850 X 630 X 670	102	
18	S	1000 X 770 X 670	140	
19	T	2500 X 850 X 800	180	
20	U	1500 X 700 X 700	120	
21	W	1200X900X600	120	
22	Y	450 X 200 X 200	10	

Table 2 – WOODEN BOX DETAILS

BOX TYPE	BOX SIZE (in MM)	BOX Wt (in KG)	Carrying Capacity
1	320X250X260	10	
2	320X250X430	15	
3	430X370X430	25	
4	670X670X470	65	
5	720X630X600	75	
6	1000X770X660	100	
7	1100X430X670	80	
8	1200X1200X900	80	
9	1300X770X1050	155	
10	2500X850X800	225	
11	2000X1500X1200	305	
12	1850X1050X1250	260	
13	2000X800X800	180	
14	2600X1500X1600	470	
15	250X250X600	20	
16	250X250X880	30	
17	300X300X700	25	
18	380X380X880	45	
19	510X510X1400	60	
20	570X570X1400	80	
21	575X575X1875	105	
22	3600X1100X1100	390	
23	900X500X800	110	
24	2000X950X740	225	
25	1600X1120X700	220	
26	2500X2000X1200	490	
27	2900X1900X1400	525	
28	3000X1000X900	370	
29	3200X2200X950	450	
30	2150X1100X750	325	
31	2000X2000X700	130	
32	700X1200X1325	130	

CORPORATE STANDARD



Table 3 – STEEL BOXES

SL NO	TYPE	DIMENSION IN MM			WEIGHT	CARRYING CAPACITY (KGS)
		LENGTH	BREADTH	HEIGHT		
1	I	2480	1680	1500	339	4500
2	II	1200	900	600	061	2000
3	IIB	1800	850	950	115	2500
4	III	900	600	600	029	1000
5	IV	600	450	500	019	750
6	V	400	350	300	011	500

TYPICAL PATTERN OF WOODEN BOX

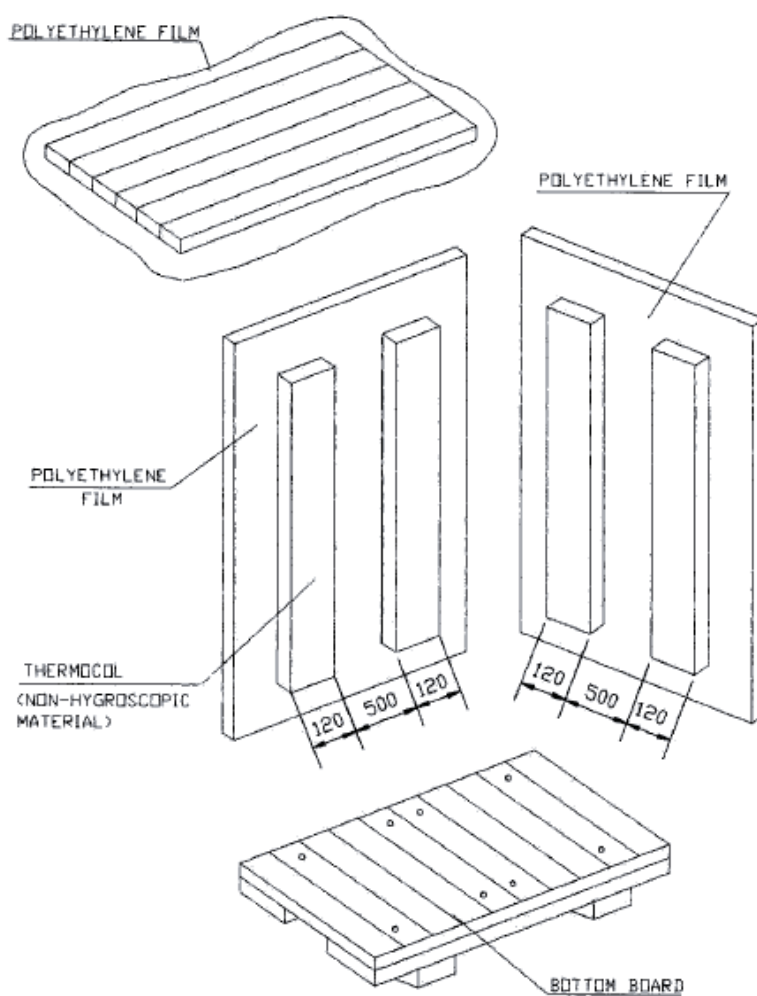

Figure 1



CORPORATE STANDARD

AA0490010

Rev. No. 02

PAGE 9 of 24

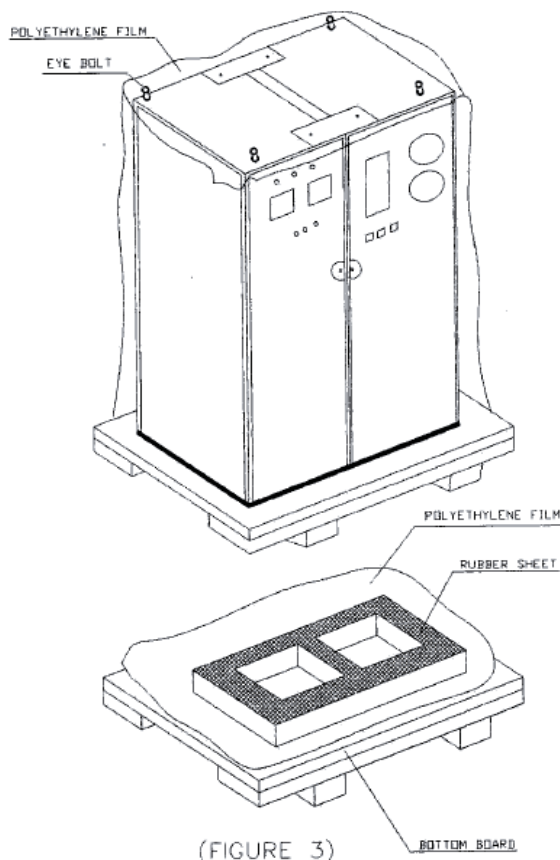

(FIGURE 3)

Figure 2

9.2 STEEL CONTAINERS:

Steel containers for packing can be used in case of repeated supplies of the same equipment. Empty steel containers are to be returned back from customer's end and to be reused for the next supplies. The containers are to be made of structural steel as per AA10108 with proper reinforcement with I, C and T Sections. Depends on the availability of resources & requirements units may be allowed to use standard cargo containers also instead of fabricated steel boxes.

- Following precautions are to be taken during packing: -
- Put the machine in the steel container properly,
- Cover the machine with polythene.
- To arrest the movement in the steel container necessary wooden Blocks/Battons may be put.
- Put cover on steel, container and Bolt Properly

9.3 SEALED PACKING:

Components sub-assemblies and assemblies sensitive to climatic conditions shall be packed seal tight. All the openings of the sensitive components, sub-assemblies and assemblies shall be blanketed to prevent the ingress of dust and moisture. The components sub-assemblies and assemblies are completely covered with 2 layers of polyethylene sheet. All sharp corners and edges are to be protected by rubber mats to prevent the polyethylene sheet from damage. Top surface of the case shall be free from dents to prevent rain water pockets.



10 MARKINGS/STENCILINGS

MARKINGS ON PACKING CASES

1. THIS PLANT STANDARD PRESCRIBES THE VARIOUS CAUTION SIGNS AND OTHER MARKINGS ON PACKING CASES.
2. DIMENSIONS IN THE TABLE 1 SHALL BE USED FOR MAKING STENCILS ONLY.

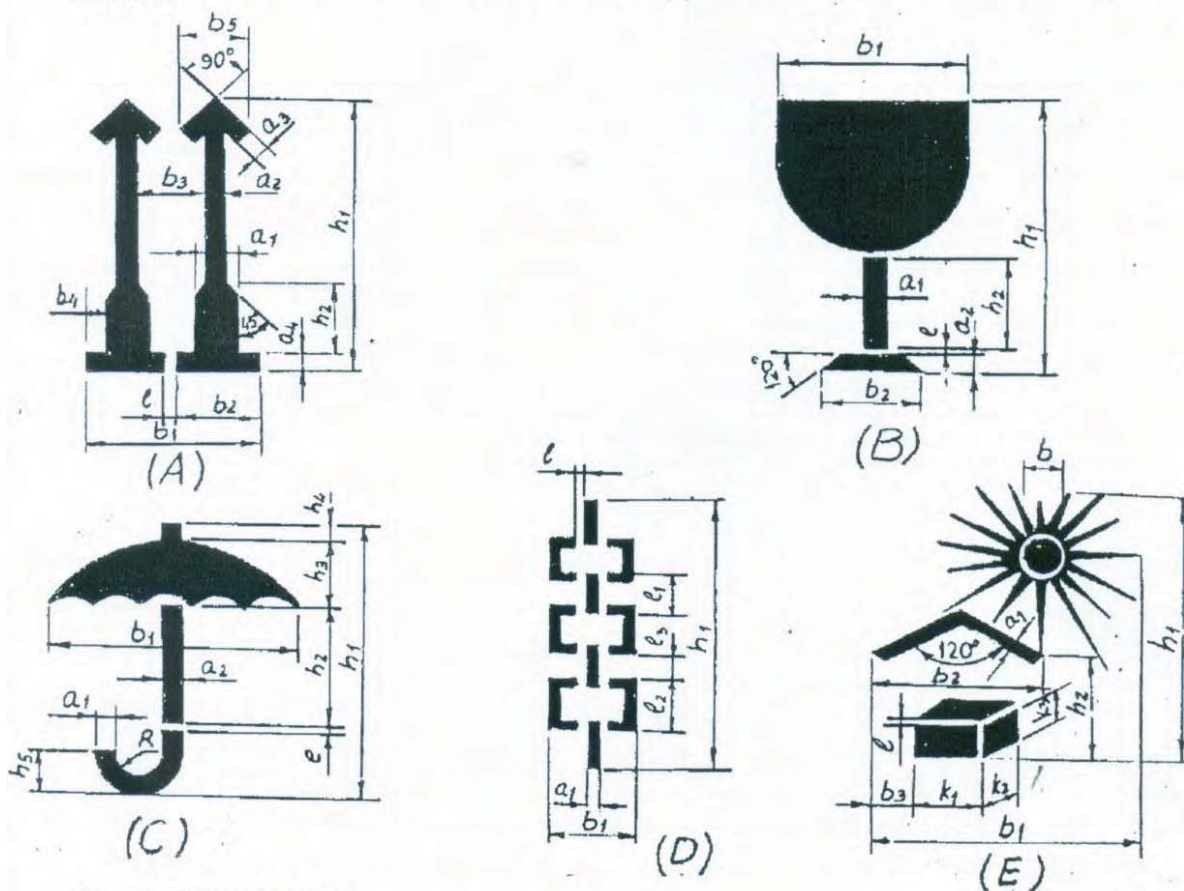

- A. UPRIGHT
- B. FRAGILE
- C. PROTECTION FROM FALLING OR CONDENSING MOISTURE.
- D. SLINGING POSITION
- E. PROTECTION FROM DIRECT RADIATIONS.



Figure 3

	CORPORATE STANDARD	AA0490010
		Rev. No. 02
		PAGE 11 of 24

DESIGN- ATION	DIMENSION IN MM																							
	a1	a2	a3	a4	b1	b2	b3	b4	b5	b	l	h1	h2	h3	h4	h5	k1	k2	k3	l1	l2	l3	R	
A	1	12	5	5	4	52	25	19	8	21		2	84	23										
	2	17	7	7	6	75	36	29	11	30		3	119	33										
	3	24	10	10	8	104	50	38	16	42		4	168	46										
	4	34	14	14	11	147	71	59	23	60		5	239	65										
B	1	5	5			50	33					2	84	25										
	2	7	7			71	47					3	119	36										
	3	10	10			100	66					4	168	50										
	4	14	14			142	94					5	239	71										
C	1	4	3			66						2	80	39	19	5	11							6
	2	6	4			85						3	114	55	27	7	16							9
	3	8	6			120						4	160	78	38	10	22							12
	4	11	9			170						5	227	110	54	14	31							17
D	1	6				30						4	148									30	30	10
	2	9				42						5	209									42	42	14
E	1	3				69	47	10			16	2	91	26					17	8	11			
	2	4				98	67	15			23	3	128	33					24	11	16			
	3	6				138	94	20			32	4	182	62					34	16	22			

Table 4

Black and Red Marking Ink to IS:1234 "Ink, Stencil, Oil Base, For Marking Porous Surfaces" or duplicating ink stencilling, oil base for marking porous surfaces.

All cases containing fragile items are to be stencilled with red marking and stencilling paint/ink

"HANDLE WITH CARE", "FRAGILE DO NOT TURN OVER".

Besides the caution signs the product information's shall be stencilled of letters with 13mm to 50mm height.

In case of consignment consists of more than one package, each package shall carry its package no as given in shipping list. All caution signs shall be stencilled in high quality full glossy out door finishing paint red in colour (AA56126). All other markings shall be carried out in black enamel(AA56126).

Caution signs & other markings shall be stencilled on both the end shooks & the side shooks.

Caution sign (for slinging) shall be stencilled only on side shooks at the appropriate place.

Note: In case the size of package is small for using the stencils, then hand written letters/figures shall be allowed.

AA0490010

Rev. No. 02

PAGE 12 of 24

CORPORATE STANDARD

 BHEL – <unit> - <location> - <pin>	
CONSIGNEE	
MATERIAL	
CUSTOMER REF.	MO. NO.
DESPATCH ADVICE NOTE NO	CASE NO
DIMENSIONS(MM) L x B x H	NET WT -KGS
	GROSS WT -KGS
SPECIAL INSTRUCTIONS	HANDLE WITH CARE - KEEP DRY DO NOT DROP - DO NOT TILT

Figure 4 – TYPICAL MARKING PLATE (225 X 170)

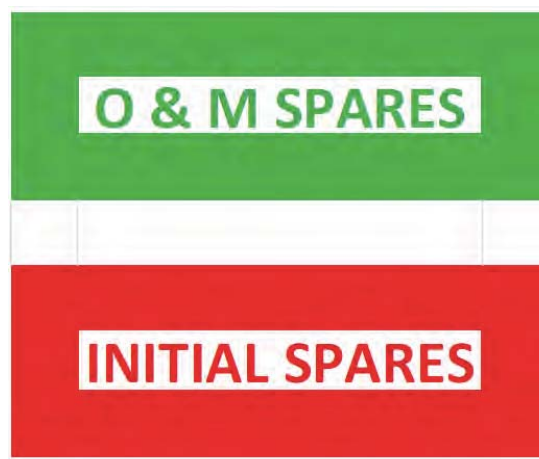

Figure 5

Easy spares [Initial and O&M] Traceability and Identification at units and as well as at sites:

11 RECYCLING OF INCOMING WOODEN PACKING CASES**OBJECTIVES**

- To utilize useable wood of incoming packing cases, for manufacturing of new packing boxes.
- To recycle incoming wooden packing cases, as such, wherever possible.

	<h2>CORPORATE STANDARD</h2>	AA0490010
		Rev. No. 02
		PAGE 13 of 24

- 1) All incoming wooden packing cases received from suppliers /customers will be opened carefully, with the intention of reusing them, by Shop.
- 2) After carefully taking out the contents, the empty wooden packing cases will be shifted by Shop to the specified locations i.e. bin / nearly spaces, already earmarked in stores.
- 3) Material shifting contractor engaged by store, will collect all such wooden packing cases and scrap wood from specified points, on a regular basis.
- 4) After collecting / loading the empty packing cases/ scrap wood, contractor will take the carrier first to Weighment Bridge for weighment, thereafter; he will go to Carpentry, where Carpentry representative will identify the packing cases which can be used by Carpentry for manufacturing of New Packing Boxes. All such identified packing boxes will be unloaded and handed over to Carpentry by contractor.
- 5) These packing boxes will be made re-useable after necessary rectification and additional work.
- 6) Contractor will again take the carrier for weighment and this second reading will also be recorded on the same "Weighment Slip".
- 7) Weight of empty packing cases / scrap wood taken will be calculated on the basis of 1st and 2nd weighment readings recorded on the "Weighment Slip". A copy of "Weighment Slip" (where both the weighment readings are recorded) will be given by the contractor to the carpentry representative. Based on this "Weighment Slip", carpentry will maintain a register in which details of quantity received will be recorded.
- 8) All "Weighment Slips" will invariably be signed by carpentry representative (even when no boxes have been unloaded by carpentry). Store will accept the scrap wood only if "Weighment Slips" are signed by carpentry representative.
- 9) Balance empty packing cases / scrap wood will be handed over by contractor to Store, for storing in scrap yard.
- 10) A separate area in Scrap yard will be provided, for executing the work of denailing of wooden packing cases, under supervision of carpentry.
- 11) Carpentry contractor will identify packing cases / scrap wood for denailing, which will be handed over to him by Store, at Scrap yard, for denailing and further operation.
- 12) Quality and Carpentry will jointly inspect the wood generated by de-nailing process and will prepare "INSPECTION CUM RECEIPT REPORT OF USEABLE WOOD RECEIVED FROM TPS – STORE BY CARPENTRY".
- 13) After acceptance of the wood by Quality and Carpentry, the same will be shifted to carpentry for receipt and its record will be maintained by carpentry.
- 14) This will be a Permanent Productivity Project executed by carpentry. "Productivity Savings" duly verified at the current Purchase Order rate of wood, will be sent every month to Resource Management Department, for highlighting it in their monthly progress report.

12 STANDARD METHOD OF PACKING

Table 5 - Standard Method of Packing

DESCRIPTION	CASE	CRATE	SKID	BUNDLE	BARE	DRUM	METAL DRUM	FIBRE DRUM
PRESSURE VESSELS								
TOWERS					O			
TANKS					O			
VESSELS					O			
GASKETS	O							
FASTENERS	O							
COVERS		O						
EXCHANGERS								

714945/2022/PS-PEM-MAX

DESCRIPTION	CASE	CRATE	SKID	BUNDLE	BARE	DRUM	METAL DRUM	FIBRE DRUM
AA0490010								
Rev. No. 02								
PAGE 14 of 24								
CORPORATE STANDARD								
								
HEAT EXCHANGERS					○			
TUBE BUNDLE	○							
SHELL					○			
AIR FIN COOLERS					○			
COLOUMNS, MOTOR SUSPENSIONS, PLENUM CHAMBERS, SCREEN GUARDS, ETC					○			
BEARING BLOCKS	○							
FANS	○	○						
MOTORS	○							
GASKETS	○							
FASTENERS	○							
TEST FLANGES			○					
TEST RINGS			○					
COVERS			○					
CRYOGENIC VESSELS								
COLD CONVERTERS					○			
HORIZONTAL STORAGE TANKS					○			
TRANSPORTATION TANK					○			
COLD BOX					○			
DRYING UNIT					○			
DRYING BOTTLES					○			
MOISTURE SEPARATORS					○			
SILENCERS					○			
ONGC SKIDS					○			
VAPORISER		○						
SPECIAL PRODUCTS								
SI/VI PIPING		○						
CRO BIO CONTAINERS	○							
AIR BOTTLES	○							
TITANIUM BOTTLE	○							
WAR HEAD CONTAINER	○							
MISSILE CONTAINER	○							
FUEL CONTAINER	○							
AIR LOCK ASSEMBLY	○							
BOILER DRUMS					○			
BOILER ITEMS								
COILS			○					
PANELS					○			
HEADERS			○		○			
FEEDERS								
MACHINED ITEMS								
SHELL SEGMENTS					○			

	CORPORATE STANDARD							AA0490010	
								Rev. No. 02	
								PAGE 15 of 24	
DESCRIPTION	CASE	CRATE	SKID	BUNDLE	BARE	DRUM	METAL DRUM	FIBRE DRUM	
SHELL SEGMENTS IN STACKS					0				
SPHERE PETALS									
COLOUMNS, BASE PLATES, TIERCOS, PIPES, NOZZLE E1, F1, INTERNAL PIPES, PADS ETC.					0				
ROLLERS	0								
VALVE TRAYS									
VALVE TRAY COMPONENTS	0								
LATTICE GIRDERS		0							
FASTENERS	0								
GASKETS	0								
SUB CONTRACTS									
FAB STRUCTURALS					0				
SUPPORTING STRUCTURALS					0				
STRUCTURE SUB ASSEMBLY					0				
FAB PIPES					0				
GRATINGS					0				
STAIR CASES					0				
HANDRAILS/ PLATFORMS					0				
BOUGHT OUT COMPONENTS									
IRON & STEEL (LIKE PLATES, BEAMS, ANGLES, CHANNELS ETC.)					0				
PIPE FITTINGS									
CS PIPES, TUBES					0				
SS PIPES, TUBES					0				
FIN TUBES	0								
ELBOWS		0			0				
FLANGES	0	0							
VALVES	0								
GAUGES	0								
DEMISTERS		0							
ABSCRBANTS (LIKE MOLECULAR SIEVES, ACTIVATED ALUMINA, MOBILE SORBID)						0			
PAINT TINS		0							
PAINT DRUMS						0			
IGNITORS	0								
SPRAY NOZZLES	0								
ELECTRICAL INSTRUMENTATION									
MOTORS, PUMPS, COMPRESSORS, TURBINES	0								
SWITCH BOARDS, DISTRIBUTION BOARDS, STARTERS, JUNCTION BOXES		0							
INDICATORS, VIBRATOR SWITCHES	0								

AA0490010

Rev. No. 02

PAGE 16 of 24

CORPORATE STANDARD

DESCRIPTION	CASE	CRATE	SKID	BUNDLE	BARE	DRUM	METAL DRUM	FIBRE DRUM
CABLE BUNDLES, CABLE DRUMS					○			
CABLE TRAYS, CABLE RACKS, EARTHING MATERIAL		○						
OPERATIONAL SPARES	○							

13 PROCEDURE FOR HANDLING OF COMPONENTS

The purpose of this procedure is to protect the quality of the components/equipment while handling in various stages of manufacturing packing & despatching.

- 13.1** Adequate care shall be taken in handling the material, and components to avoid damage during receipts, storage issue manufacture & despatch operations.
- 13.2** Appropriate material handling equipment like fork lifters, cranes etc. shall be used where needed.
- 13.3** Lifting by crane and transportation by trolley of critical items and large components like rotors castings etc. shall be done carefully.
- 13.4** For critical items, where specified, special handling fixtures shall be used for lifting.
- 13.5** Slings and shackles used for lifting the components/equipment shall be checked for fitness and suitability before use.
- 13.6** Slings used on machined surfaces shall be suitably padded. No slings shall be used on journal surfaces.
- 13.7** Precision machined components like blades, catches, rollers etc. shall be lifted using suitable wooden pallets.

13.8 HANDLING OF COMPONENTS ON RECEIPT/DESPATCH

Before loading/unloading a packing case from the carrier look for the following shipping instructions painted on the packing case.

- a) The markings showing the upright position.
 - b) The markings showing the sling position
 - c) Markings showing the fragile contents.
 - d) Other required markings as per clause no.10
- 13.8.1** Appropriate cranes and slings should be used for different components/ cases. Slings should normally make an angle as minimum as possible (width wise) but in no case more than 15°.
- 13.8.2** Handling and lifting should be done without jerks or impacts.
- 13.8.3** Immediately after receipt of the goods, the packing should be examined all-round for any sign of damage. If necessary, lift the cover or a number of boards of the case so as to make the contents visible. In the event of sealed packing being used the plastic sheeting should not be damaged. It is imperative that the packing material is restored in original condition after the inspection.
- 13.8.4** On receipt of the equipment it should be checked with the shipping list and missing or damage if any should be reported immediately. It is important to arrange for immediate examination to determine the extent of the damage, the cause of the damage and where applicable the person or persons responsible for the damage. According to general practice when transporting by railway or by road vehicle the carrier concerned should be immediately called upon (within specified periods) for jointly establishing a statement of the damage. This is essential as a basis for a subsequent claim and possible damage report to the insurance company.
- 13.8.5** Protective coating applied on machined surfaces should not be disturbed. The plastic covering should be put back carefully so that it prevents ingress of dust and moisture. Some packing may have vapour phase inhibitor (VPI) paper enclosed inside the packing cases. This should be restored to its original place as far as possible.

	CORPORATE STANDARD	AA0490010
		Rev. No. 02
		PAGE 17 of 24

13.8.6 Silica gel and such other chemicals kept in the box as desiccants and indicators should also be left in the box itself.

14 GENERAL GUIDELINES FOR ODC TRANSPORTATION/DESPATCH

Based on the Dimensions/Weight indicated in the Transportation Sketch, the type of Trailer is decided and indicated in the Tender Enquiry.

14.1 TRANSPORTATION:

1. LOW BED TRAILERS (LB 8):

Well Bed Length	: 10000mm
Over Gooseneck	: 13000mm
Width	: 3000mm
Carrying Capacity	: 40MT

2. LOW BED TRAILERS (LB 16):

Well Bed Length	: 12000mm
Over Gooseneck	: 16000mm
Width	: 3000mm
Carrying Capacity	: 75MT

3. TOW TYPE TRAILERS (WITH FRONT DOLLEY 16 TYRES): 12000MM length (for Exceptional equipment length: 30000mm and above)

Bigger Dia equipment are loaded in the Well with overhanging.

Smaller Dia equipment with excess length are loaded over Gooseneck with rear hanging.
The Vehicle Dimensions are defined above are only guidelines for selection based on actual Dimensions/ Weight of the Consignment

14.2 PACKING:

For all ODCs, Wooden Saddles are cut to the diameter of equipment as per the Transportation Sketch .

Wooden Saddles	For Diameter up to 4000mm	For Diameter above 4000mm
Length:	1836/2743mm (6'0"/9'0")	3353mm (11'0")
Width:	300mm (1'0")	300mm (1'0")
Height:	Saddle + one/two wedges a top	Saddle + three/four wedges a top

Number of Saddles:	
Minimum	3 in case of Loading inside Well +1 when loaded on Gooseneck
Maximum:	4 in case of Loading inside Well +2 when loaded on Gooseneck

For Securing the equipment firmly on the Trailer, 19mm (3/4"), wire rope with 25mm (1") Heavy Duty Turn Buckles / BD Clamps are used as Lashing for the equipment.

14.3 NUMBER OF LASHINGS:

CORPORATE STANDARD



	CONSIGNMENT LOADED INSIDE WELL BED	CONSIGNMENT LOADED OVER GOOSENECK
a) up to 40MT	4 (2 Single Line lashing 2 Double Line Lashing)	5 (3 Single Line Lashing 2 Double Line Lashing)
b) 40MT to 60MT	5 (3 Single Line Lashing 2 Double Line Lashing)	5 (Single Line Lashing 3 Double Line Lashing)
c) 60MT and above	5 (2 Single Line Lashing 3 Double Line Lashing)	6 (3 Single Line Lashing 3 Double Line Lashing)

15 GUIDELINES FOR HANDLING/LOADING/LASHING

15.1 HANDLING



Figure 6

Before unloading the jobs Completely painted and neatly stencilled will be checked.

Pipes with split type end cover will be checked



CORPORATE STANDARD

AA0490010

Rev. No. 02

PAGE 19 of 24



Figure 7

All Coil Tubes to be provided with End Caps.



Figure 8

Neatly stacked Coil Assemblies.

CORPORATE STANDARD**Figure 9**

Columns to be lifted with Nylon belts. This protect painting, edges and attachments.

**Figure 10****15.2 LOADING**

All the components to be transported by putting inside the properly fabricated Crating



CORPORATE STANDARD

AA0490010

Rev. No. 02

PAGE 21 of 24



Figure 11

Small components may fall down while transporting without closed crating and there are chances of missing of small parts. Hence, it is always better to transport small components in closed containers/crating. Loose to be being shipped in a closed crating.



Figure 12

AA0490010

Rev. No. 02

PAGE 22 of 24

CORPORATE STANDARD

No component loaded over the crating.

**Figure 13**

Headers supported with wooden V blocks at 3 meters interval.

**Figure 14**

Spacers in between each coil assembly.



CORPORATE STANDARD

AA0490010

Rev. No. 02

PAGE 23 of 24



Figure 15

Goose pipe to be provided with rubber pad protects removal of painting and damage to the job.



Figure 16

15.3 LASHING

Use Nylon belts only for lashing of all components. It prevents removal off painting and cut in the materials.



Figure 17

Nylon Belts used for lashing the beams.



Figure 18

16 PRODUCT WISE SPECIAL INSTRUCTION

Additional instructions of packing not included in this standard shall be covered by individual product standard.

17 REFERRED STANDARDS (Latest publications including amendments):

- | | | | | |
|------------|------------|------------|------------|------------|
| 1) AA51420 | 2) AA55619 | 3) AA51414 | 4) IS:3401 | 5) AA10108 |
| 6) AA56126 | 7) AA51402 | 8) AA51401 | 9) IS:1234 | |



CORPORATE STANDARD

AA0490006

Rev. No. 01

PAGE 1 of 3

VACUUM PACKING FOR ELECTRONIC COMPONENTS

1 GENERAL

This standard lays down the packing instructions for packing of components / Electronic module / Assemblies to be dispatched against Customer contracts.

2 SCOPE

This procedure covers method of packing electronic components using vacuum packing in a wooden packing boxes.

3 OBJECTIVE

To establish a rust proof safe packing procedure and where the components required to protect against temperature and humidity. In general minimum temperature +5 deg C and maximum temperature 45 deg C, and relative humidity between 10% to 40%.

4 PACKING BOX

Wooden Box shall be made as per BHEL Standard AA0490010 for Domestic/ AA0490009 for Export/ AA0490004 for Seaworthy packing. Size of the box as per the contract requirement which has to be checked by QC.

5 PACKING PROCEDURE

- a) Cleaning parts shall be thoroughly cleaned just before VCI (Volatile Corrosion Inhibitor) Vacuum packing. Finger prints on cleaned items are to be avoided as the same are very corrosive.
- b) VCI Rust preventive oil (Ferrous grade oil base) shall be applied to all the components to withstand any corrosion.

6 VCI VACUUM PACKING

- a) Bubble wrapping the items VCI vacuum packing.
- b) Appropriate vapour corrosive packets one pouch (1 gm. /pouch) of VCI Anticorrosive Powder and one pouch (10gm./ pouch) of VCI Desiccant per 1000 cub. meter packing space shall be placed inside the VCI vacuum packing.
- c) All the components shall be separately packed using VCI laminated Aluminium foils from which air/moisture are removed by the air vacuum device and sealed thoroughly using heat sealing machine. At the time of the evacuation the vacuum inside the pack should be less than 0.5 ata.
- d) One identification slip containing component information such as description of item, Material No. Customer PO, Item No. Quantity etc. shall be put inside the VCI vacuum packing.
- e) Top cover of the wooden box shall be sealed only after final clearance from QC for confirmation of above.
- f) All boxes should be covered by water proof tarpaulin over top and on all sides.
- g) The packing boxes shall be covered with GI sheets (0.25 -0.4mm thick) on all the sides for Export / Seaworthy packing.
- h) Vacuum packing room temperature and Relative Humidity should be maintained as mentioned below:

Min. +5 deg. C and Max. 45 deg. C, Relative humidity between 10% to 40%.

Revisions:

APPROVED:

PROCEDURAL GUIDELINES COMMITTEE –
PGC (Packing)

Rev. No. 01

Amd. No.

Reaffirmed

Prepared

Issued

Dt. of 1st Issue

Dt: 12-06-2018

Dt:

Year:

EDN, Bangalore

Corp. R&D

31-05-2018

AA0490006

Rev. No. 01

PAGE 2 of 3

CORPORATE STANDARD**7 COMPONENTS REQUIRED****7.1 VCI laminated Aluminium foil**

Volatile Corrosion Inhibitor (VCI) safe foil shall be with aluminium barrier laminated which is flexible, heat sealable, water vapour and anticorrosion resistant barrier laminate of polyester, Aluminium foil and VCI Polyethylene. It is used as a primary packaging material for packing metal components and sealed with the help of a heat sealer after vacuuming with vacuum machine maintaining the humidity level below 40 RH inside the package.

7.2 Composition construction of VCI laminated Aluminium foil

- a) PET Film : 12 Microns
- b) Bonding layer : 2 Microns
- c) Aluminium Foil : 9 Microns
- d) Bonding layer : 2 Microns
- e) VCI Poly film : 100 Microns
- f) Total thickness : 125 Microns + or – 5%

7.3 Properties of VC Laminated Aluminium foil

- a) Basic Weight : 138 gsm +/- 8%
- b) Sealing condition : 180 C/ 2 sec
- c) Tensile strength
 - MD: 20 kgf
 - CD: 18 kgf
- d) Tear Strength
 - MD 4.8 kg
 - CD:3.4 kg
- e) Heat Seal Strength : 30.380 N/cm
- f) WVTR Value : 0.05gms/m /24 hrs.
- g) OTR Value : 0.1 cc/m/24 hrs

8 MARKING OF PACKING BOX

Mark the following information on the two adjacent sides of the each package

- a) Material No.
- b) Customer PO
- c) Item No.
- d) Quantity
- e) Storage Requirement : Indoor
- f) Content Description : Electronic Module
- g) Net weight (in kg)
- h) Dimension (L x W x H in centimetres)
- i) Project Name
- j) Consignee
- k) Water proofing (Umbrella Stencilling)
- l) Upside direction



CORPORATE STANDARD

AA0490006

Rev. No. 01

PAGE 3 of 3

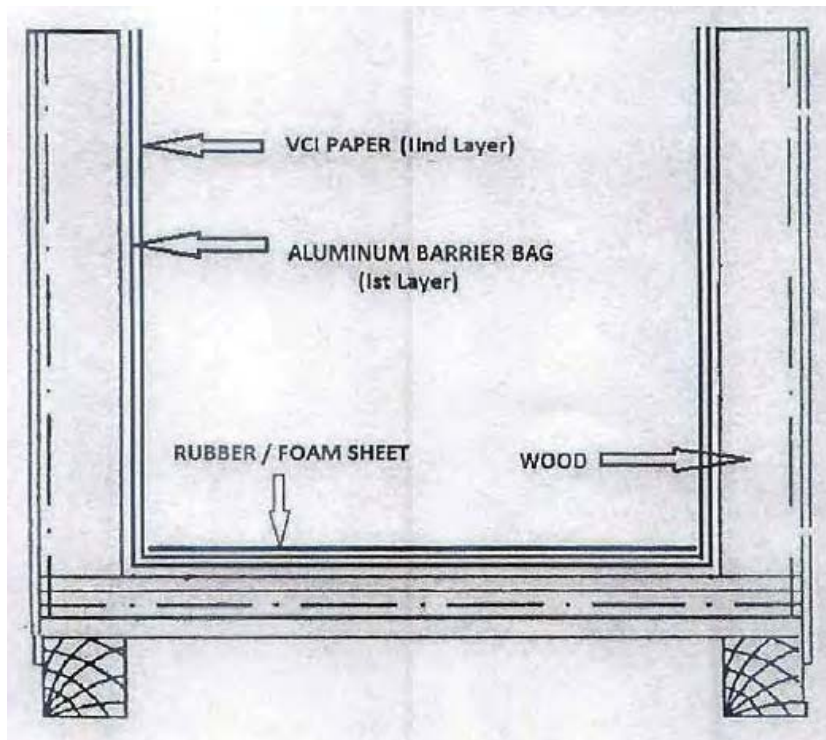

Figure 1



CORPORATE STANDARD

AA0490008

Rev. No. 01

PAGE 1 of 4

VACUUM PACKING FOR ELECTRICAL COMPONENT

1 GENERAL

This standard lays down the packing instructions for packing of components / Electrical components Stator/ Rim punching, Wound Pole/ Field Coils and Stator coils / bars to be dispatched against Customer contracts.

2 SCOPE

This procedure covers method of packing component in a wooden packing boxes.

3 OBJECTIVE

To establish a rust proof safe packing procedure and where the components required to protect against temperature and humidity. In general minimum temperature +5 deg C and maximum temperature 45 deg C, and relative humidity between 10% to 40%.

4 PACKING BOX

Wooden Box shall be made as per BHEL Standard AA0490010 for Domestic/AA0490009 for Export/ AA0490004 for Seaworthy packing. Size of the box as per the contract requirement, which has to be checked by QC.

5 PACKING PROCEDURE

- a) All items packed are to be marked by QC with "OK" stickers. Varnished stator punchings are to be brought down to room temperature before labelling them "OK" for packing. Do not pack hot/warm stator punchings that have is just received from the varnishing.
- b) Packing of stator punchings, wound pole/ field coils and stator coils / bars should be done in a covered shed.
- c) Packed materials are to be stacked in proper alignment and to be kept in wooden packing.

6 Additional Packing Methodology for Stator / Rim Punchings (Double stacking) only

In order to eliminate the use of studs avoid double stack packaging per box. Where double stacked packing boxes are unavoidable, the stator /rim punchings are to be securely tightened using GI studs, nuts and soft material washers (rubber/plastic). GI studs, nuts and soft material only to be used in case of double stacking of rim / stator punchings (with holes). Use soft rubber washers to seal the punctured opening at the bottom from where the studs pass in each layer of VCI (Volatile Corrosion Inhibitor) paper, polythene and tarpaulin sheet in case of rim /stator punchings (with holes).

- a) GI studs with rubber washer to be placed initially inside the wooden packing box.
- b) Over the wooden base, place water proof tarpaulin sheet.
- c) Rubber washer shall be placed after the layer of tarpaulin sheet.
- d) Then place a layer of porous plastic sheet with total thickness of at least 5mm (for cushioning and reduces the chances of damage to punchings).
- e) Place the Aluminium Barrier laminated Bags over this porous sheet, place the rubber washer over it.
- f) Place VCI papers on the Aluminium barrier bag and fix with rubber washer.

Revisions:

APPROVED:
PROCEDURAL GUIDELINES COMMITTEE –
PGC (Packing)

Rev. No. 01

Amd. No.

Reaffirmed

Prepared
EDN, BangaloreIssued
Corp. R&DDt. of 1st Issue
31-05-2018

Dt: 12-06-2018

Dt:

Year:

AA0490008

Rev. No. 01

PAGE 2 of 4

CORPORATE STANDARD

- g) PVC Pipes shall be inserted over the GI studs. These pipes are to be used to cover each stud, to protect its direct contact and hence rubbing with punchings.
- h) Now place the stack of punchings over the VCI paper and securely tighten the punchings using nuts and soft material, washers.
- i) Each layer should be secured in position. Wrap the punchings with VCI paper and properly sealed separately using an adhesive tape.
- j) Silica Gel packets are to be placed over the VCI paper and uniformly distributed inside the boxes on the VCI paper to remove/prevent moisture.
- k) Aluminium barrier laminated bag has secured in position and properly sealed by using heat sealing machine and air to be drained out by using vacuum pump. At the time of the evacuation the vacuum inside the pack should be less than 0.5ata.

Use two separate VCI papers for doubled stacked boxes independently covering each stack. Similarly two Aluminium barrier laminated bag are to be used to wrap the two stacks independently, as explained above.

7 Additional Packing Methodology for Wound Pole/ Field Coils and Stator Coils/Bars only

- a) Over the wooden base, place the waterproof tarpaulin sheet.
- b) Then place a layer of porous plastic sheet with total thickness of at least 5mm (for cushioning and reduces the chances of damage to Wound pole/field coils and stator coils/ bars.
- c) Place the Aluminium barrier laminated bag over this porous sheet.
- d) Place the VCI paper (Volatile Corrosion Inhibitor as per BHEL Standard AA51406) on the Aluminium barrier laminated bag along with rubber washer.
- e) Bare copper portion of field coils and stator coils / bars to be covered by VCI paper pouch and fasten with VCI tape.
- f) Now place the wound pole, stack of field coil and stator coil / bars over the VCI paper.
- g) Each layer should be secured in position. Wrap wound pole / field coils and stator coils / bars with VCI paper and properly sealed separately using an adhesive tape.
- h) Silica Gel packets are to be placed and uniformly distributed inside the boxes on the VCI paper to remove/prevent moisture.
- i) Then Aluminium barrier laminated bag has secured in position and properly sealed by using heat sealing machine and air to be drained out by using vacuum pump. At the time of evacuation the vacuum inside the pack should be less than 0.5ata.
- j) The VCI paper must contact the stator / rim punchings, wound pole / field coils and stator coils/bars. It has to ensure that the VCI paper, Aluminium barrier bag should not get damage / puncture during the packing process.
- k) Top cover of the wooden box shall be sealed only after final clearance from QC for confirmation of above.
- l) All boxes should be covered by water proof tarpaulin over top and on all sides.
- m) The packing boxes shall be covered with GI sheets (0.25 -0.4mm thick) on all the sides for Export / Seaworthy packing.
- n) Vacuum packing room temperature and Relative Humidity should be maintained as mentioned below:
Min. +5 deg. C and Max. 45 deg. C, Relative humidity between 10% to 40%.

	<h2>CORPORATE STANDARD</h2>	AA0490008
		Rev. No. 01
		PAGE 3 of 4

8 COMPONENT REQUIRED

8.1 VCI laminated Aluminium foil

Volatile Corrosion Inhibitor (VCI) safe foil shall be with aluminium barrier laminated which is flexible, heat sealable, water vapour and anticorrosion resistant barrier laminate of polyester, Aluminium foil & VCI Polyethylene. It is used as a primary packaging material for packing metal components and sealed with the help of a heat sealer after vacuuming with vacuum machine maintaining the humidity level below 40 RH inside the package.

8.2 Composition construction of VCI laminated Aluminium foil

- a) PET Film : 12 Microns
- b) Bonding layer : 2 Microns
- c) Aluminium Foil : 9 Microns
- d) Bonding layer : 2 Microns
- e) VCI Poly film : 100 Microns
- f) Total thickness : 125 Microns + or – 5%

8.3 Properties of Aluminium Barrier laminated Bag

- a) Basic Weight : Unit: g/sq. m 150 +/- 5
- b) Tensile strength : Unit: N/sq. mm MD: 40 (min.)
Unit: N/sq. mm TD: 41 (min.)
- c) Water Vapour Transmission : Unit: g/m² 0.01 in 24 hrs. at 38 deg C & 90% RH(max)
- d) Oxygen Transmission : Unit: cm³/m² 0.02 in 24 hrs. at 38 deg C & 90% RH (max)
- e) Sealing Temp. : Unit : Degree C 180-220 deg C

9 MARKING ON PACKING BOX

Mark the following information on the two adjacent sides of the each package.

- a) Box No.
- b) Customer PO
- c) Product Name.
- d) Project Name
- e) Quantity
- f) Storage Requirement : Indoor
- g) Net weight (in kg)
- h) Dimension (L x W x H in centimetres)
- i) Consignee
- j) Water proofing (Umbrella Stencilling)
- k) Upside direction
- l) Sling position indicator

CORPORATE STANDARD

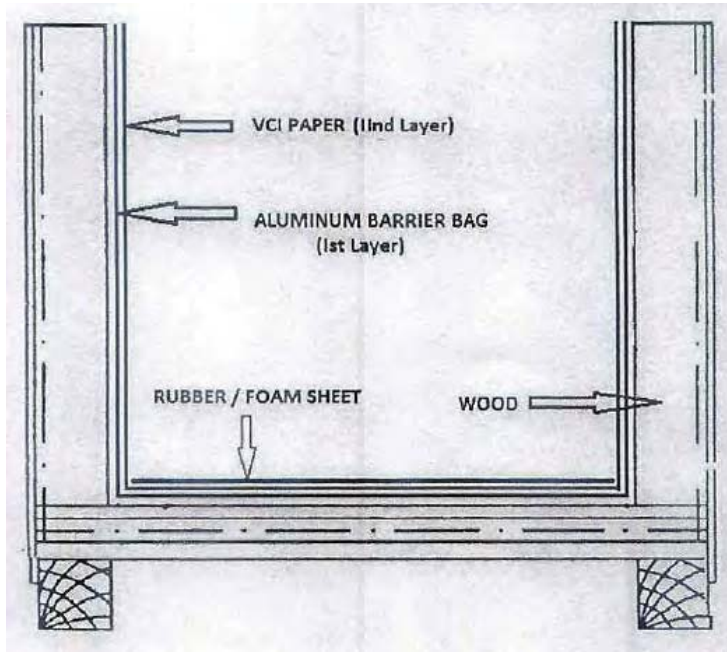

Figure 1



Figure 2



Figure 3



Figure 4



Figure 5

**2X500 MW NTPL TUTICORIN FGD****COMPRESSED AIR SYSTEM**

SPECIFICATION No: PE-TS-483-555-A002

VOLUME : II B

SECTION : E / ANNEXURE-VI

REV 00

DATE: FEB 2022

SHEET: 1 OF 2

ANNEXURE-VI

LIST OF OPERATIONAL SPARES

	2X500 MW NTPL TUTICORIN FGD		SPECIFICATION No: PE-TS-483-555-A002	
	COMPRESSED AIR SYSTEM		VOLUME : II B	
			SECTION : E / ANNEXURE-VI	
	REV 00	DATE: FEB 2022		
	SHEET: 2 OF 2			

LIST OF OPERATIONAL SPARES

Sl.no	Description	Qty. (Each compressor)			Unit	Qty. for 2 nos. Compress ors
		Initial fill (at vendor works)	Intervening Period	During PG Test		
1	Lube oil	Included	NA	1	Lot / Compressor	2
2	Lube oil filters with seals	Included	1	1	Sets / Compressor	4
3	Air filters with gaskets (as applicable)	Included	1	1	Sets / Compressor / Dryer	4
4	Service kit including seals, washers and rings for intercooler (as applicable)	NA	NA	1	Sets / Compressor / Dryer	2
5	Service kit including seals, washers and rings for after cooler (as applicable)	NA	NA	1	Sets / Compressor / Dryer	2

2 X 500 MW NTPL TUTICORIN – FGD

TECHNICAL SPECIFICATION

FOR

COMPRESSED AIR SYSTEM

VOLUME-III

(TECHNICAL SCHEDULES)



BHARAT HEAVY ELECTRICALS LTD
POWER SECTOR PROJECT ENGINEERING MANAGEMENT
PPEI, NOIDA-INDIA



2X500 MW NTPL TUTICORIN FGD

COMPRESSED AIR SYSTEM

SPECIFICATION NO. PE-TS-483-555-A002

VOLUME : III

SECTION : 1

REV: 00

DATE: FEB 2022

SHEET 1 OF 1

VOLUME: III
SECTION: 1

LIST OF DOCUMENTS TO BE SUBMITTED
WITH BID

714945/2022/PS-PEM-MAX



2 X 500 MW NTPL TUTICORIN – FGD

COMPRESSED AIR SYSTEM

SPEC. NO.: PE-TS-483-555-A002

VOLUME: III

SECTION: 1

REV. NO. 0 DATE: FEB 2022

SHEET 1 OF 1

**CHECK LIST FOR LIST OF DOCUMENTS TO BE SUBMITTED BY BIDDER ALONG WITH
THE BID**

SI No.	Item Description	Yes/No
1	Schedules to be submitted dully filled up with bidder's signature and stamp. 1) Technical Deviation Schedule, if any. 2) Filled, Signed & Stamped copy of Guaranteed Power Consumption for Compressed Air System. 3) Compliance cum Confirmation certificate.	
2	Resolution to pre-bid clarifications, if any, duly stamped and signed by the bidder enclosed with the bid	
3	Un-priced bid- clearly indicating 'QUOTED' and 'NOT-QUOTED' against each item.	
4	Signed & stamped copy of Electrical feeder list attached with specification.	
5	Supporting Documents meeting PQR requirements	

Name: _____

Signature: _____

Designation: _____

Company: _____

Date: _____

Bidder Stamp

	2X500 MW NTPL TUTICORIN FGD COMPRESSED AIR SYSTEM	SPECIFICATION NO. PE-TS-483-555-A002	
		VOLUME : III	
		SECTION : 2	
		REV: 00	DATE: FEB 2022
		SHEET 1 OF 1	

**VOLUME-III
SECTION 2
COMPLIANCE CUM CONFIRMATION CERTIFICATE**



2 X 500 MW NTPL TUTICORIN – FGD

COMPRESSED AIR SYSTEM

SPEC. NO.: PE-TS-483-555-A002

VOLUME: III

SECTION: 2

REV. NO. 0 DATE: FEB 2022

SHEET 1 OF 2

COMPLIANCE CUM CONFIRMATION CERTIFICATE

The bidder shall confirm compliance with following by signing/ stamping this compliance certificate (every sheet) and furnish same with the offer.

- a) The scope of supply, technical details, construction features, design parameters etc. shall be as per technical specification & there are no exclusions other than those mentioned under “exclusion” and those resolved as per ‘Schedule of Deviations’, if applicable, with regard to same.
- b) There are no other deviations w.r.t. specifications other than those furnished in the ‘Schedule of Deviations’. Any other deviation, stated or implied, taken elsewhere in the offer stands withdrawn unless specifically brought out in the ‘Schedule of Deviations’.
- c) Bidder shall submit QP in the event of order based on the guidelines given in the specification & QP enclosed therein. QP will be subject to BHEL/ NTPL approval & customer hold points for inspection/ testing shall be marked in the QP at the contract stage. Inspection/ testing shall be witnessed as per same apart from review of various test certificates/ Inspection records etc. This shall be within the contracted price with no extra implications to BHEL after award of the contract.
- d) All drawings/ data-sheets/ calculations etc. submitted along with the offer shall be considered for reference only, same shall be subject to BHEL/ NTPL approval in the event of order.
- e) The offered materials shall be either equivalent or superior to those specified in the specification & shall meet the specified/ intended duty requirements. In case the material specified in the specifications is not compatible for intended duty requirements then same shall be resolved by the bidder with BHEL during the pre - bid discussions, otherwise BHEL/ NTPL decision shall be binding on the bidder whenever the deficiency is pointed out.

For components where materials are not specified, same shall be suitable for intended duty, all materials shall be subject to approval in the event of order.

- f) The commissioning spares shall be supplied on ‘As Required Basis’ & prices for same included in the base price itself.
- g) All sub vendors shall be subject to BHEL/ NTPL approval in the event of order.
- h) Guarantee for plant/equipment as applicable, shall be as per relevant clause of GCC /SCC /Other Commercial Terms & Conditions.
- i) In the event of order, all the material required for completing the job at site shall be supplied by the bidder within the ordered price even if the same are additional to approved billing break up, approved drawing or approved Bill of quantities. This clause will apply in case during site commissioning additional requirements emerges due to NTPL comments. No extra claims shall be put on this account.
- j) Schedule of drawings submissions, comment incorporations & approval shall be as stipulated in the specifications. The successful bidder shall depute his design personnel to BHEL / NTPL office for across the table resolution of issues and to get documents approved in the stipulated time.

714945/2022/PS-PEM-MAX

**2 X 500 MW NTPL TUTICORIN – FGD****COMPRESSED AIR SYSTEM**

SPEC. NO.: PE-TS-483-555-A002

VOLUME: III

SECTION: 2

REV. NO. 0 DATE: FEB 2022

SHEET 2 OF 2

- k) As built drawings shall be submitted as and when required during the project execution.
- l) The bidder has not tempered with this compliance cum confirmation certificate and if at any stage any tempering in the signed copy of this document is noticed then same shall be treated as breach of contract and suitable actions shall be taken against the bidder.

SIGNATURE: _____

NAME : _____

DESIGNATION: _____

COMPANY: _____

DATE: _____

COMPANY SEAL

714945/2022/PS-PEM-MAX



2X500 MW NTPL TUTICORIN FGD

COMPRESSED AIR SYSTEM

SPECIFICATION No: PE-TS-483-555-A002

VOLUME: III

SECTION : 3

REV. 00

DATE: FEB 2022

SHEET 1 OF 1

VOLUME: III
SECTION: 3
PRE-BID CLARIFICATION SCHEDULE



**2X500 MW NTPL TUTICORIN FGD
COMPRESSED AIR SYSTEM**

SPECIFICATION NO. PE-TS-483-555-A002

VOLUME : III

SECTION : 4

REV: 00

DATE: FEB 2022

SHEET 1 OF 1

**VOLUME-III
SECTION 4
ELECTRICAL LOAD DATA**

RANGE BOUND ELECTRICAL LOAD LIST FOR COMPRESSED AIR SYSTEM

LOAD TITLE	RATING (KW)		UNIT (U)/STN (S)	Nos.		VOLTAGE CODE*	FEEDER CODE**	EMER. LOAD (Y)	CONT.(C)/INTT.(I)	STARTING TIME >5 SEC (Y)	LOCATION	BOARD NO.	CABLE		BLOCK CABLE DRG. No.	CONTROL CODE	REMARKS	LOAD No.
	NAME PLATE (KW)	MAX. CONT. DEMAND (MCR)		RUNNING	STANDBY								SIZE CODE	NOs				
1	2	3	4	5	6	7	8	9	10	11	12	13	14	15	16	17	18	19

Common Compressor (Instrument Air & Service Air) Motor	110		S	1	1	D	U		C		Compressor House							
Common Compressor (Instrument Air & Service Air) Oil pump / cubicle fan (if applicable)	2 – 3.5		S	1	1	D	S		C		Compressor House							
Common Compressor (Instrument Air & Service Air) Control Panel	0.5-1.5		S	1	1	E	S		C		Compressor House						UPS grade supply by C&I	
Sequential Panel	1		S	1	0	E	S		C		Compressor House						UPS grade supply by C&I	
Air Dryer Panel	0.12 - 0.5		S	1	1	E	S		C		Compressor House							
Auto Drain Trap	0.3		S	2	0	E	S		I		2 nos. feeder for air receivers outside compressor house.							

NOTES: 1. COLUMN 1 TO 12 & 18 SHALL BE FILLED BY THE REQUISITIONER (ORIGINATING AGENCY); REMAINING COLUMNS ARE TO BE FILLED UP BY PEM (ELECTRICAL)
 2. ABBREVIATIONS : * VOLTAGE CODE (7):- (ac) A=11 KV, B=6.6 KV, C=3.3 KV, D=415 V, E=240 V (1 PH), F=110 V (cc): G=220 V, H=110 V, J=48 V, K=+24V, L=-24 V
 **: FEEDER CODE (8):- U=UNIDIRECTIONAL STARTER, B=BI-DIRECTIONAL STARTER, S=SUPPLY FEEDER, D=SUPPLY FEEDER (CONTACTER CONTROLLED)



LOAD DATA (ELECTRICAL)

JOB NO.	483	ORIGINATING AGENCY		PEM (ELECTRICAL)	
PROJECT TITLE	TUTICORIN TPS – FGD	NAME	DATA FILLED UP ON		
SYSTEM	COMPRESSED AIR SYSTEM	SIGN.	DATA ENTERED ON		
DEPTT. / SECTION	MAUX / PF	SHEET 1 OF 1	REV. 00	DE'S SIGN. & DATE	
				431 of 439	

**2X500 MW NTPL TUTICORIN FGD****COMPRESSED AIR SYSTEM**

SPECIFICATION No: PE-TS-483-555-A002

VOLUME: III

SECTION: 5

REV. 00

DATE: FEB 2022

SHEET 1 OF 1

SECTION: 5
LIST OF DRAWINGS

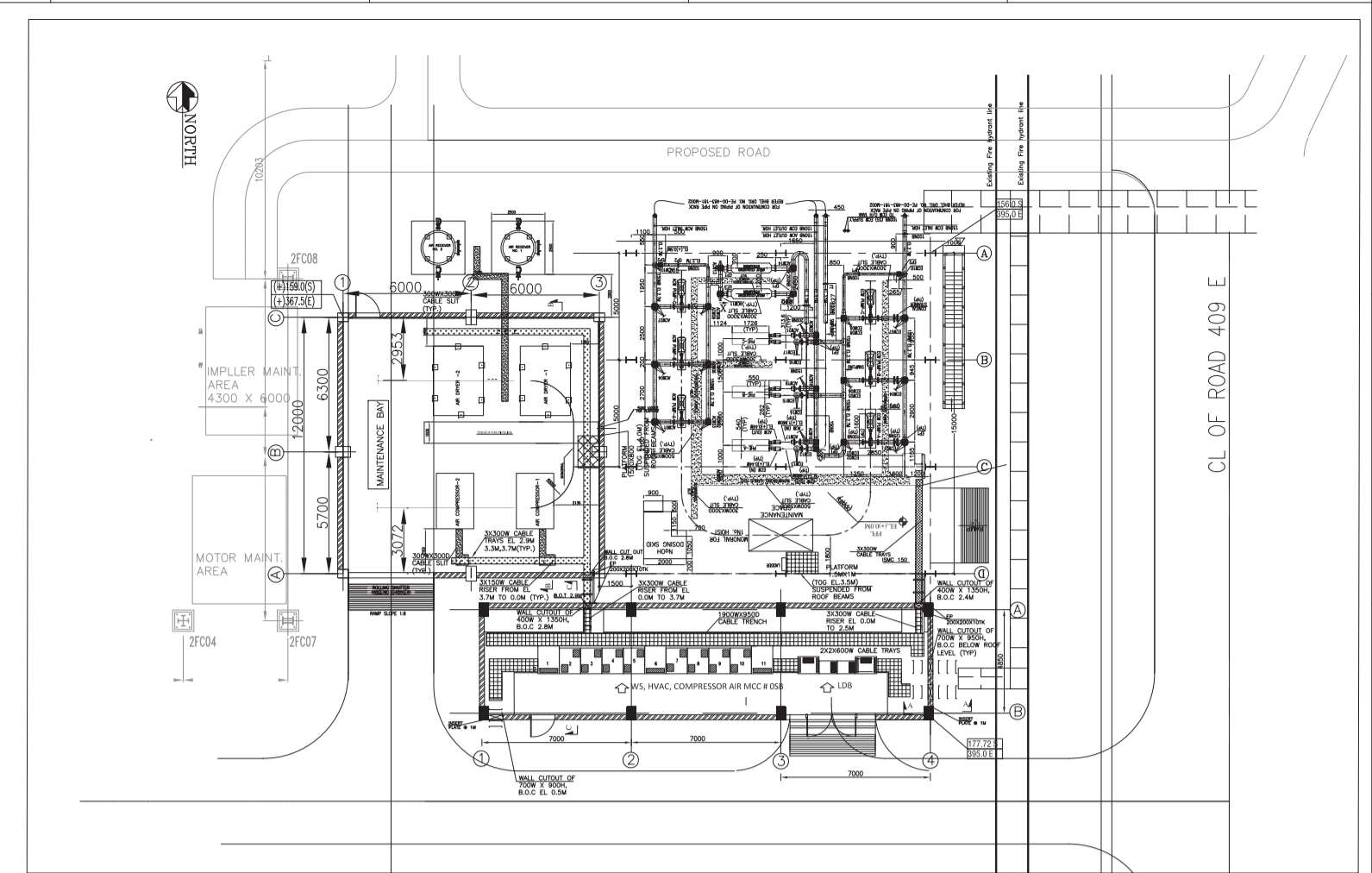
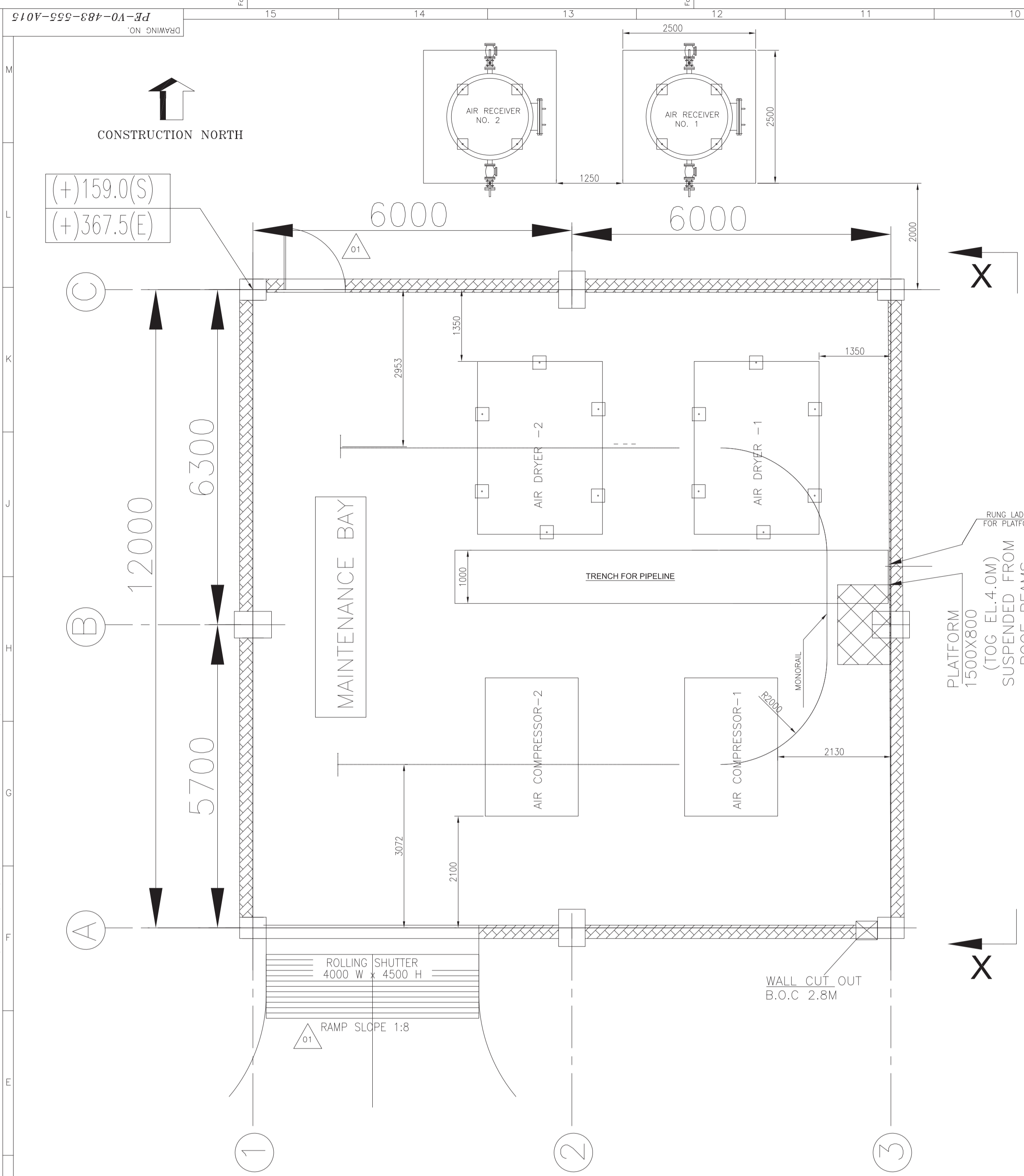

KEY PLAN

FOUNDATION DETAIL

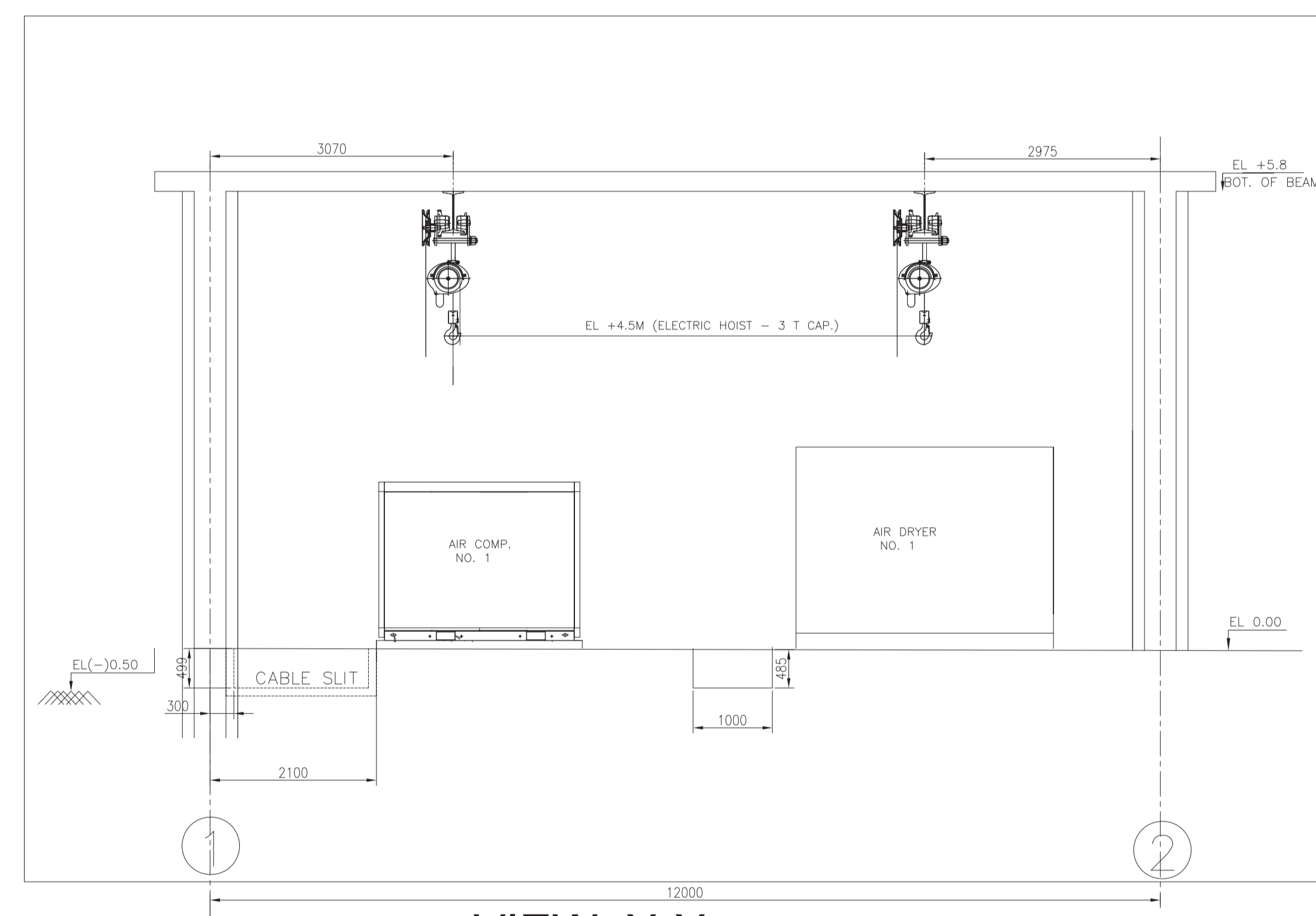

VIEW X-X

NOTES :-

- 1) ALL DIMENSIONS ARE IN MM & LEVELS ARE IN METERS. EL 0.00 M CORRESPONDS TO FFL OF PLANT WHICH IS 2.90M FROM CHART DATUM AND CHART DATUM IS -0.64M FROM MEAN SEA LEVEL(MSL)
- 2) THE EQUIPMENT SIZES SHOWN IN THE DRAWING IS INDICATIVE ONLY AND WILL BE CONFIRMED AFTER VENDOR DATA. THE MAXIMUM ANTICIPATED SIZE HAS BEEN SHOWN IN THE DRG.
- 3) PIPING, VALVES, OPENINGS AND CABLE SLIT DETAILS SHALL BE CONFIRMED AFTER FINALIZATION OF EQUIPMENT SUPPLIER.

REFERENCE DRAWING :-

1) PLANT LAYOUT OF FGD SYSTEM	PY-DG-0-M162-1252-01
2) VENT. ARRANGEMENT FOR VARIOUS AUXILIARY BUILDING	PE-V0-483-571-A305
3) ELECTRICAL EQUIPMENT AND CABLING LAYOUT IN COMPRESSOR HOUSE	PE-DG-483-100-E010
4) COMPRESSOR BUILDING - ARCHITECTURAL PLAN	PE-DG-483-667-C035

DEVELOPMENT CONSULTANTS PVT. LIMITED.

Reviewed only for general conformance with contract drawings and specifications. Contractor to be responsible for any errors and for fulfillment of detailed requirements of contract documents.

ACTION 2 DATE 10 2021

DISTRIBUTED BY: R

1 Approved	3 Returned with Comments. Please Resubmit.
2 Approved except as noted. Forward final drawing	4 For information only

SEE COVERING LETTER

LETTER REF NO. DATE.

CUSTOMER:	एनएलसी तमिलनाडु पावर लिमिटेड NLC TAMILNADU POWER LIMITED
CONSULTANT:	M/s DEVELOPMENT CONSULTANTS PVT LTD
PACKAGE:	FLUE GAS DESULPHURIZATION SYSTEM (FGD) PACKAGE
PROJECT:	NLC TAMILNADU POWER LIMITED (NTPL) 2x500 MW COAL FIRED UNITS AT TUTICORIN
JOB NO. 483	STATUS CONTRACT
DRG./REF. NO. (INTERNAL)	PRINT SCALE IN METRE
DEPT. NAME	DRG. CODE
BHARAT HEAVY ELECTRICALS LTD	DRN MK -SD- 14.06.21
POWER SECTOR	DESN MK -SD- 14.06.21
PROJECT ENGINEERING MANAGEMENT	CHD SK -SD- 15.08.21
NEW DELHI	APPD SKB -SD- 15.06.21
TITLE :	COMPRESSOR HOUSE LAYOUT
DRAWING NO.	PE-V0-483-555-A015
SHEET 1 OF 1	REV. 01

COPY RIGHT AND CONFIDENTIALITY OF THE DRAWING IS RESERVED BY DEVELOPMENT CONSULTANTS PVT. LIMITED. ALL DIMENSIONS ARE IN MM. ALL DIMENSIONS ARE IN MM. ALL DIMENSIONS ARE IN MM.



2 X 500 MW NTPL TUTICORIN – FGD

COMPRESSED AIR SYSTEM

SPECIFICATION NO. PE-TS-483-555-A002

VOLUME : III

SECTION : 6

REV: 00

DATE: FEB 2022

SHEET 1 OF 1

VOLUME-III
SECTION 6
Guaranteed Power Consumption for Compressed Air
System

(To be filled by bidder & be submitted along with offer)

SECTION-6				Doc No: PE-TS-483-555-A002		
Guaranteed Power Consumption For Compressed Air System				Rev No: 0		
				Date of issue: Feb-22		
NAME OF PROJECT:		TUTICORIN TPS – FGD				
NAME OF PACKAGE:		COMPRESSED AIR SYSTEM				
TECHNICAL SPECIFICATION:		PE-TS-483-555-A002				
S.No. (1)	Description of Equipments (2)	Nos. of Equipments (3)		Total Guaranteed Power Consumption for Each Equipment at Motor Input Terminals & control Panel (4)	Duty Factor (5)	Total (KW) (6) = (3A)*(4)*(5)
		Working A	Standby B			
1	Air Compressors (Oil free Screw type) of capacity 9 NM3/min.	1	1	to be filled by bidder	0.5	to be filled by bidder
2	HOC Air Dyrer of matching capacity.	1	1	to be filled by bidder	0.5	to be filled by bidder
					TOTAL	to be filled by bidder
Note :						
1	Estimated Power Consumption Figure for the compressed air system (For Working Drives Only) considered is 47 KW .					
2	Bidders Guaranteed power consumption at motor input terminal at rated duty of Air Compressor considering motor efficiency as confirmed by motor OEM including Air Drying Plant (Heater and Blowers, as applicable) as furnished in guaranteed schedule shall be demonstrated by the successful bidder during performance testing at works/site.					
3	The price quoted by the bidder shall be loaded @ INR 2,71,000 /- for every additional KW increase in consumption from the base figure indicated at Note no. 1.0 above.					
4	In case the successful bidder fails to establish / prove the guaranteed values of power consumption (base figure of auxiliary power consumption or the GPC quoted by bidder, whichever is higher) on actual performance testing at the manufacturing works / site, penalty INR 4,06,500 /- per KW increase in power consumption figure shall be levied.					
Particulars of bidder / authorised representative						
Name	Designation	Signature	Date	Date	Company Seal	

	2 X 500 MW NTPL TUTICORIN – FGD	SPECIFICATION No: PE-TS-483-555-A002	
	COMPRESSED AIR SYSTEM	VOLUME: III	
		SECTION-7	
		REV. 00	DATE: FEB 2022

**VOLUME-III
SECTION - 7
ANNUAL MAINTENANCE CONTRACT SERVICES**

	2 X 500 MW NTPL TUTICORIN – FGD	SPECIFICATION No: PE-TS-483-555-A002	
	COMPRESSED AIR SYSTEM	VOLUME: III	
		SECTION-7	
		REV. 00	DATE: FEB 2022

ANNUAL MAINTENANCE CONTRACT SERVICES

The bidder scope covers the Annual maintenance contract (AMC) for Preventive / Breakdown maintenance for a period of One (1) year from the date of successful handover of Compressed air system to end customer or the date as agreed mutually between the construction manager and the successful bidder.

AMC scope also covers all regular maintenance by certified and trained service engineers. Total Six visits (06) (Including 2 Breakdown visit) shall be provided in a year. And each visit consists 1 to 2 days, depending upon the nature of work.

1.0 Scope of Work:

The scope of work includes:

1. To carry out Preventive Maintenance checks as per mentioned schedule provided by bidder ensuring min. one routine visit per quarter, to attend Air compressors, its motor, Air dryer and all its accessories.
2. In case of breakdown, bidder shall depute qualified Service manpower and rectify the same with in strict time frame, not exceeding 48 hours.
3. Spares, consumables, maintenance kits etc. required for preventive AMC / breakdown shall be provided to successful bidder's service provider by BHEL on the written request basis. Any specific item not available in BHEL inventory, shall be provided by bidder on mutual settlement of related commercial issues.

2.0 Detail description of major equipment: -

SL. NO.	EQUIPMENT	MAKE & MODEL	Qty.
1	AIR COMPRESSOR WITH MOTOR (9 Nm ³ /min. @ 8.5 kg/cm ² (g))	As per Bidder	2 nos. (1W+ 1S)
2	AIR DRYER (9 Nm ³ /min. @ 8.5 kg/cm ² (g))	As per Bidder	2 nos. (1W+ 1S)

3.0 General Checklist for Air compressor: -

The checklists are intended for general description of work to be carried out. They are not intended to cover all minute details. The work shall be executed in accordance with Manufacturer's O&M Manuals and modern techniques. Preventive Maintenance checks includes but not limited to as specified below:

MAINTENANCE OF SCREW COMPRESSOR

- Carry out external cleaning of equipment.
- Check the oil level in the tank if low top-up with oil.
- Change the lube oil & lube oil filter element.
- Check the tightness of foundation bolt & take corrective action, if applicable.
- Check the coupling gear installed between compressor and motor.
- Check & clean the air breather in oil tank.
- Setting and checking of safety valves
- Pressure switch setting, Trips condition checking.

	2 X 500 MW NTPL TUTICORIN – FGD	SPECIFICATION No: PE-TS-483-555-A002	
	COMPRESSED AIR SYSTEM	VOLUME: III	
		SECTION-7	
		REV. 00	DATE: FEB 2022

- Blow down valve functioning and repairing if necessary
- Clean the inlet air filter / oil filter element.
- Checking / cleaning of all heat exchangers.
- Checks the leakage in oil line, water line and airline if found then rectify the same.
- Cleaning of cooling water inlet line strainer, back flushing of air and oil cooler, air purging oil scavenging & connecting tube, Cleaning & servicing of moisture separator installed at compressor outlet, cleaning of all moisture & dust separating filter elements as prescribed by manufacturer.
- Check for Electrical connections intact.
- Check for compressor control panel as per manufacturer recommendation.
- Any other maintenance as recommended by manufacturer.

MAINTENANCE OF AIR DRIER

- Carry out external cleaning of equipment.
- Clean the suction filter/ moisture strainer.
- Check the tightness of foundation bolts & take corrective action if required.
- Assisting for inspection / repair / servicing during expert visit as per instructions.
- Check change over valve.
- Check for any leakages in pipeline.
- Check for Electrical connections intact.
- Equipment external and internal cleaning.
- Any other maintenance as recommended by manufacturer.

4.0 Tools and tackles

Tools and tackles required for handling the component will be provided to the Bidder (successful bidder) on the written request basis. Bidder shall not claim any delay or compensation due to unavailability of these items, if any. In such cases bidder need to arrange the required tools and tackles at his own cost.

5.0 Bidder is to arrange all the safety gears like helmets, air plugs, safety shoes etc. during the maintenance.

6.0 | breakdown, Bidder is to depute service manpower within 48 hrs. without fail.

7.0 For Breakdown Maintenance, Bidder is to service and operate the compressor with satisfactory operating parameters within a week (6 working days) of reporting.

8.0 Bidder is to submit the Servicing Report (SR) of completed Breakdown Maintenance.

9.0 If any damage to the equipment and its accessories due to improper maintenance by bidder shall be recovered from the bidder.

PRICE SCHEDULE

NAME OF PROJECT:		2 X 500 MW NTPL TUTICORIN FGD TPS		Vendor Name						
NAME OF PACKAGE:		COMPRESSED AIR SYSTEM		Enquiry No		PE/PG/NTF/E-6902/2021 Dated 05.03.2022				
TECHNICAL SPECIFICATION:		PE-TS-483-555-A002		Supply			Services		Total Scope	
S. No.	DESCRIPTION	UNIT	QTY	Total Ex-Works Price (INR)	Freight %	Freight in INR	Total FOR Site Price excluding GST (INR)	Unit Price (INR)	Total Price (INR)	Grand Total (Supply +E&C+ O&M) (INR)
1.0	Total lump sum firm price for Supply part, Services part comprising of design (i.e. preparation and submission of drawing /documents including "As Built" drawings and O&M manuals), engineering, manufacture, fabrication, assembly, inspection / testing at vendor's & sub-vendor's works, painting, maintenance tools & tackles, fill of lubricants & consumables along with spares for erection, start up and commissioning as required, forwarding, proper packing, shipment and delivery at site, unloading, handling, transportation & storage at site, in-site transportation, assembly, erection & commissioning, final painting at site, minor civil work, trial run at site, preparation of layout drawings and carrying out Performance guarantee tests at site, training of customer/client and O&M staff , handover in flawless condition of the package to the end customer complete with all accessories and AMC for one year for the total scope defined as per BHEL NIT & tender technical specification, amendment & agreements till placement of order.	Lot	1							-
2.0	MAJOR BREAK-UP OF PRICES GIVEN IN 1.0 ABOVE.									
2.1	Total lump sum firm price for Supply part comprising of design (i.e.preparation and submission of drawing /documents including "As Built" drawings and O&M manuals), engineering, manufacture, fabrication, assembly, inspection / testing at vendor's & sub-vendor's works, painting, maintenance tools & tackles, fill of lubricants & consumables alongwith spares for erection as required, startup and commissioning spares, forwarding, proper packing, shipment and delivery at site, preperation of layout drawings for the total scope defined as per BHEL NIT & tender technical specification as specified above, amendment & agreements till placement of order. (Break-up as per Annexure-I)	Lot	1	-		-	-			-
2.2	Total lumpsum firm prices for Services part comprising of unloading, handling, transportation & storage at site, in-site transportation, assembly, erection & commissioning, final painting at site, minor civil work, trial run at site and carrying out Performance guarantee / Functional / Demonstration tests at site (As applicable), , training of customer/client O&M staff and handover in flawless condition of the package to the end customer complete with all accessories for the total scope defined as per BHEL NIT & tender technical specification as specified above, amendment & agreements till placement of order.	Lot	1						-	-
2.3	Total lumpsum firm price for AMC (Annual Maintenance Contract) for one (1) years from the date of handover of the complete system to the end customer or as agreed mutually with the construction manager and the successful bidder. (as per section VII, vol III of technical specification)	Lot	1						-	-
Particulars of bidder / authorised representative										
Name	Designation	Signature	Date	Company Seal						

ANNEXURE-I

NAME OF PROJECT:		2 X 500 MW NTPL TUTICORIN FGD TPS		PE/PG/NTF/E-6902/2021 Dated 05.03.2022	
NAME OF PACKAGE:		COMPRESSED AIR SYSTEM			
TECHNICAL SPECIFICATION:		PE-TS-483-555-A002			
S. No.	DESCRIPTION	UNIT	QTY	Unit Ex-Works Price (INR)	Total Ex-Works Price (INR)
BREAK-UP OF SUPPLY PRICES GIVEN IN 2.1 OF MAIN SHEET.					
2.1	Total lump sum firm price for Supply part comprising of design (i.e.preparation and submission of drawing /documents including "As Built" drawings and O&M manuals), engineering, manufacture, fabrication, assembly, inspection / testing at vendor's & sub-vendor's works, painting, maintenance tools & tackles, fill of lubricants & consumables alongwith spares for erection as required, startup and commissioning spares, forwarding, proper packing, shipment and delivery at site, preperation of layout drawings for the total scope defined as per BHEL NIT & tender technical specification as specified above, amendment & agreements till placement of order. (Break-up as per Annexure-I)	Lot	1		-
Break up prices for items covered in clause 2.1 above.					
2.1.1	Air Compressors (Oil Free Screw type) each of minimum 9 NM3/Min capacity @ 8.5 kg/cm2 (min.) discharge pressure with suction filter with silencer, inter cooler and after cooler with moisture separators, automatic drain traps, instruments, control system, cable lugs, glands and other accessories including electric motor drive.	Nos.	2		-
2.1.2	Air Drying Plants Heat of compression (HOC) Rotary type/ Twin Tower Type of capacity matching with compressor (minimum 9NM3/Min) with all instruments, control panels and other accessories as specified.	Nos.	2		-
2.1.3	Air Receivers with instruments, relief valve, isolation valve, drain connection with automatic trap stations (zero purge air loss type) and other accessories as specified.	Nos.	2		-
2.1.4	Inter connecting cooling water, drain piping and compressed air piping as specified including fittings and valves etc. for complete Compressed air system.	Lot	1		-
2.1.5	Field instruments, junction box, Tools & Tackles etc. for complete Compressed air system.	Lot	1		-
2.1.6	Sequential Panel for equal no. of running hours	No.	1		-
2.1.7	Operational spares for complete Compressed air system.				
a	Lube oil (Qty. for 1 Lot in Ltr. shall be as per oil tank capacity for One Compressor)	Lot	2		-
b	Lube oil filters with seals	Nos.	4		-
c	Air filters with gaskets	Nos.	4		-
d	Service kit including seals, washers and rings for intercooler	Nos.	2		-
e	Service kit including seals, washers and rings for after cooler	Nos.	2		-

ANNEXURE-II
Guaranteed Power Consumption For Compressed Air System

NAME OF PROJECT:		2 X 500 MW NTPL TUTICORIN FGD TPS				
NAME OF PACKAGE:		COMPRESSED AIR SYSTEM				
TECHNICAL SPECIFICATION:		PE-TS-483-555-A002				
S.No. (1)	Description of Equipments (2)	Nos. of Equipments (3)		Total Guaranteed Power Consumption for Each Equipment at Motor Input Terminals & control Panel (4)	Duty Factor (5)	Total (KW) (6) = (3A)*(4)*(5)
		Working	Standby			
		A	B			
1	Air Compressors (Oil free Screw type) of capacity 9 NM3/min.	1	1	to be filled by bidder	0.5	to be filled by bidder
2	HOC Air Dyrer of capacity matching with air compressor (minimum 9NM3/Min).	1	1	to be filled by bidder	0.5	to be filled by bidder
					TOTAL	to be filled by bidder
Note :						
1	Estimated Power Consumption Figure for the compressed air system (For Working Drives Only) considered is 47 KW.					
2	Bidders Guaranteed power consumption at motor input terminal at rated duty of Air Compressor considering motor efficiency as confirmed by motor OEM including Air Drying Plant (Heater and Blowers, as applicable) as furnished in guaranteed schedule shall be demonstrated by the successful bidder during performance testing at works/site.					
3	The price quoted by the bidder shall be loaded @ INR 2,71,000 /- for every additional KW increase in consumption from the base figure indicated at Note no. 1.0 above.					
4	In case the successful bidder fails to establish / prove the guaranteed values of power consumption (base figure of auxiliary power consumption or the GPC quoted by bidder, whichever is higher) on actual performance testing at the manufacturing works / site, penalty INR 4,06,500 /- per KW increase in power consumption figure shall be levied.					
Particulars of bidder / authorised representative						
Name	Designation	Signature	Date	Date	Company Seal	

ANNEXURE-II DEVIATION SHEET (COST OF WITHDRAWAL)									
PROJECT:-						2 X 500 MW NTPL TUTICORIN FGD TPS			
PACKAGE :-						COMPRESSED AIR SYSTEM			
TENDER ENQUIRY :-						PE/PG/NTF/E-6902/2021 Dated 05.03.2022			
NAME OF THE BIDDER						0			
Sl. No.	Volume/Section	Page No.	Clause No.	Technical Specification/Tender Document No	Complete Description of Deviation	Cost of withdrawal of deviation to be entered by the bidder in	Reference of price Schedule of which Cost of Withdrawal of Deviation is applicable	Nature of cost of withdrawal of deviation (Positive/Negative)	Reasons for quoting deviation
1	TECHNICAL DEVIATION								
1.01									
1.02									
1.03									
1.04									
1.05									
1.06									
1.07									
1.08									
2	COMMERCIAL DEVIATION								
2.01									
2.02									
2.03									
2.04									
2.05									
2.06									
2.07									
2.08									

NOTES:

- Cost of Withdrawal of deviation will be applicable on the basic price (i.e. excluding taxes, duties & freight) only.
- All the bidders have to list out all their technical & commercial deviations (if any) in details in the above format.
- Any deviation not mentioned above and shown separately or found hidden in offer, will not be taken cognizance of.
- Bidder shall submit duly filled unpriced copy of above format indicating "quoted" in "cost of withdrawal of deviation" column of the schedule above along with their Techno-commercial offer, wherever applicable. In absence of same, such deviation(s) shall not be considered and offer shall be considered in total compliance to NIT.
- Bidder shall furnish price copy of above format along with price bid.
- The final decision of acceptance/ rejection of the deviations quoted by the bidder shall be at discretion of the Purchaser.
- Bidders to note that any deviation (technical/commercial) not listed in above and asked after Part-I opening shall not be considered.
- For deviations w.r.t. Credit Period, Liquidated damages, Firm prices if a bidder chooses not to give any cost of withdrawal of deviation loading as per Annexure-VII of GCC, Rev-07 will apply. For any other deviation mentioned in un-priced copy of this format submitted with Part-I bid but not mentioned in priced copy of this format submitted with Priced bid, the cost of withdrawal of deviation shall be taken as NIL.
- Any deviation mentioned in priced copy of this format, but not mentioned in the un-priced copy, shall not be accepted.
- All techno-commercial terms and conditions of NIT shall be deemed to have been accepted by the bidder, other than those listed in unpriced copy of this format.
- Cost of withdrawal is to be given separately for each deviation. In no event bidder should club cost of withdrawal of more than one deviation else cost of withdrawal of such deviations which have been clubbed together shall be considered as NIL.
- In case nature of cost of withdrawal (positive/negative) is not specified it shall be assumed as positive.
- In case of discrepancy in the nature of impact (positive/negative), positive will be considered for evaluation and negative for ordering.

To be given on Letter head of Bidder

Ref:

Date:

To,

Bharat Heavy Electricals Limited
PEM, PPEI Building,
Plot No 25, Sector -16A
Noida (U.P)-201301

Reference:

Order no-F6/18/2019-PPD dated 23.07.2020 issued by Ministry of Finance.

Tender Enquiry No-.....

Offer No-.....

Name of Package:

Dear Sir,

I have read the clause regarding restriction on procurement from a bidder of a country which shares a land border with India. I hereby certify that Company name, is not from such a country and is eligible to be considered.

Thanking You,

Yours faithfully,

(Company director seal and signature)

To be given on Letter head of Bidder

Ref:

Date:

To,

Bharat Heavy Electricals Limited
PEM, PPEI Building,
Plot No 25, Sector -16A
Noida (U.P)-201301

Reference: Tender Enquiry No-.....

Name of Package:

Dear Sir,

We hereby certify that items of(Package name)
for.....(Project Name) offered by M/s(bidder's name)
having its works/office at has local content of%.

Further, it is also certified that the local content percentage (%) certified above is in line with definition of local content given in point no 2 of Public Procurement (Preference to Make in India), Order 2017-revision, having ref. no. P-45021/2/2017-PP(BE-II) dated 04.06.2020 & 16.09.2020 an M/s..... qualifies as Class-I/Class-II (strike out whichever is not applicable) local supplier.

Details of the location(s) at which the local value addition-

Yours very truly

..... (Signing Authority Name & Sign)

..... (Firm Name)

Company Stamp

Annexure-I to NIT

2.5 Construction Water

- i) Construction water shall be supplied free of cost by the Purchaser to the Contractor at a single point in the NLCIL/NTPL plant premises approximately 300 meters from the battery limit. However, in case of any eventuality leading to non-supply of construction water by the Purchase due to any account, it is the responsibility of the contractor to make his own arrangements for the uninterrupted supply of construction water for the construction activities & labour colony at their own cost. Extra claim on any account by the contractor due to non-supply of water by the Purchaser shall not be considered both for cost & time. Contractor has to make his own arrangement for laying pipelines, distribution lines including all pipes & specials required, pumping, construction of sump/overhead tank as per requirement at his own cost.
- ii) The Contractor shall be responsible to store water in sufficient quantity to meet its requirements for at least 2 (two) days in well built covered/protected water storage tanks.
- iii) The Contractor shall ensure that there is no wastage of water. He will also be responsible for maintaining the taps, pipe lines etc. in proper condition. The Contractor shall obtain prior approval of the Purchaser of its distribution scheme before laying the pipelines.

2.6 Construction Power

- i) The Contractor shall be provided with construction power at 6.6 kV for the purpose of the erection construction under the Contract only at one point in the project "Site" free of charge. Maximum of 0.75 MVA shall be given free of Cost for FGD Package as Construction power. The Contractor shall make his own arrangement for stepping down and further distribution. The Contractor

shall make its own arrangements to lay and maintain necessary supply lines for temporary power. All temporary wiring must comply with local regulations and relevant Indian Electrical Act and will be subject to the Purchaser's inspection and approval before connection to supply and later. Non-availability of power from the Purchaser shall not be an excuse for delay in completion of erection construction. Contractor may at its own cost arrange suitable back-up power, by means of DG sets.

- ii) The Contractor will supply and install all distribution cables, wires and switches etc. of rated capacity for the work starting from the source of power at its own cost. It will employ Electricians having valid Electrical Licence for carrying out the installations as well as for the maintenance works.
- iii) The Contractor will provide proper facilities to the Purchaser of the Plant concerned or his authorised representative for inspecting his temporary electrical installation as and when required. The Contractor will immediately attend to the defects so pointed out during this inspection including replacement of faulty cables, switches etc.
- iv) The Contractor shall not affect any change in the temporary installation unless permission is obtained from the Purchaser or its authorised representative.
- v) The Contractor shall be responsible for all damages, losses etc. due to fire or otherwise if it is due to his negligence, improper installation, operation and/or maintenance of his part of installations.

471144(1)/2021/PS-PEM-BOP

**2x500 MW NTPL TUTICORIN FGD
SPECIAL CONDITIONS OF CONTRACT (SCC, REV0)**

PEM / PG-III, BHEL, Noida

SPECIAL CONDITIONS OF CONTRACT (SCC) Rev-0

2X500 MW NLC TAMILNADU POWER LIMITED (NTPL) (FGD SYSTEM PACKAGE); Job No. 483

471144(1)/2021/PS-PEM-BOP

These Conditions shall be read and construed along with General Conditions of Contract (GCC) rev.07 dated 10.01.2020, to be enclosed along with the tender enquiry. In case of any conflict or inconsistency, the conditions given in SCC shall prevail over the GCC.

Sl No.	Title	Description
1.	Project Name	2X500 MW NTPL TUTICORIN FGD (Page no 1)
2.	Nature of project & Type of Bidding	Non-Mega, International Competitive Bidding (Page no 8)
3.	Customer Order Ref No	COCONTS/0009H/NTPL/FGD/2019 dated 18.04.2020 (Page no 8)
4.	BHEL's Customer	NLC TAMILNADU POWER LIMITED (NTPL) (Page no 8)
5.	NTPL GSTIN	33AACCN3238N1ZD (Page no 10)
6.	Customer Consultants	M/s Development Consultant Private Ltd (Page no 45)
7.	Consignee Address (BILL TO)	For supply package: BHEL, Power Sector-Project Engineering Management, Power Project Engineering Institute, Plot No. 25, Sector-16A, Noida, Uttar Pradesh-201301. GSTIN: 09AAACB4146P2ZC For turnkey packages (where BHEL-PEM will issue only the LOA and Purchase Order shall be issued by BHEL-PSSR): BHEL-PSSR, TEK TOWERS, 11, RAJIV GANDHI IT EXPWAY, THURAIPAKKAM, CHENNAI-600097 GSTIN:33AAACB4146P2ZL
8.	Delivery Address (SHIP TO)	CEO/NTPL, 2x500 MW Tuticorin Power Project, Harbour Estate, Tuticorin -628004 Tamil Nadu (Page no 9)
9.	BHEL Site Office Address	The Construction Manager, BHEL Site Office, NTPL, 2x500 MW Tuticorin Power Project, Harbour Estate, Tuticorin -628004 Tamil Nadu
10.	Location of Plant	At Tuticorin Taluk in Tuticorin district in the Southern Part of Tamil Nadu along the Bay of Munnar, India. Nearest Port- Tuticorin sea port is located adjacent to the plant. Nearest Airport- Nearest airstrip is located at Pudukottai at a distance of 16.5 km Nearest Railway Station- The nearest railway station is Port Trust Railway Yard at a distance of 1.0 km. Nearest Town- 5.5 km away from Tuticorin, Nearest city is Pallayamkottai which is 60 km from plant (Page no 1)
11.	Mode of Dispatch	For indigenous supplies: By Rail/Road on door delivery and freight pre-paid basis. For imported supplies: On C&F basis.
12.	BHEL GSTIN Details	For supply packages: BHEL-PEM is registered in the State of Uttar Pradesh with GSTIN 09AAACB4146P2ZC For Turnkey packages: BHEL PSSR is registered in the State of Tamil Nadu with GSTIN 33AAACB4146P2ZL
13.	Transit Insurance	In BHEL Scope. For each dispatch, vendor shall inform the following to the

471144(1)/2021/PS-PEM-BOP

		<p>Underwriter under intimation to BHEL-PEM and BHEL site office:</p> <ol style="list-style-type: none"> i. Policy No. ii. Consignee Name. iii. Consignment Details (items with their weights and value (in INR). iv. Project Name and P.O. No. V. LR No. and date, Dispatch origin and destination details, Invoice No. <p>Vendors to intimate the underwriters quoting the insurance Policy No. as mentioned in PO.</p>
14.	Dispatch intimation	<p>Yes in writing, Not less than 30 (Thirty) days prior to date of shipment and dispatch details to be sent to:</p> <ol style="list-style-type: none"> a. BHEL site office (As mentioned in Sl. No.9) b. BHEL PEM Noida (As mentioned in NIT) <p>At the point of dispatch, vendor must furnish docs required as given below through Email / Fax</p> <ol style="list-style-type: none"> i. Vendor's invoice ii. LR / RR / GR / Courier Receipt iii. Packing List/ Challan indicating the items dispatched (with their weights) iv. Insurance intimation letter informing the underwriters about the dispatches V. MDCC (of BHEL / NTPL) as applicable VI. Photograph of packing / boxes showing dispatch marking as per Sl. No. 26
15.	Document required for Vendor's payment.	<p>For materials originating from Indian territory</p> <p>For claiming the payment, documents as mentioned in GCC rev 07 shall be submitted by vendor to BHEL.</p> <p>Packing List must comply to Clause No. 19.3 of General Commercial Terms & Conditions of GCC rev. 07. Description of items in packing list shall be as per PO such that proper correlation between PO & packing list must be furnished.</p> <p>Soft copy of documents for claiming payment shall be submitted by vendor as advance copy.</p> <p>For materials originating from non-Indian Territory</p> <ol style="list-style-type: none"> 1. Three (3) original and Three (3) copies of clean bill of lading or One (1) clean original Airway Bill & Three (3) copies, in case of air freight. 2. One (1) original and Three (3) copies of signed Invoices 3. One (1) original and Three (3) copies of Packing List (clearly showing number of packages, gross weight and net weight). 4. Three (3) copies of certificate of country of origin. 5. Copy of MDCC from BHEL / NTPL (as applicable) 6. Three (3) copies of inspection certificate, if any, issued by the customer/his authorised representative. 7. Three (3) of certificate from the vendor to the effect that drawings and catalogues for customs clearance purpose

471144(1)/2021/PS-PEM-BOP

		<p>have been kept with the packages for shipment.</p> <p>8. Three (3) copies of certificate from the vendor to the effect that the contents in each case are not less than that entered in the invoices and guaranteed as per the relevant technical specifications.</p> <p>9. Shipping Specification – One (1) copy.</p> <p>10. Quality Certificate – One (1) copy.</p> <p>11. Approved Test Certificates, if any. - Three (3) copies.</p> <p>12. Guarantee Certificate – One (1) Original + One (1) copy.</p> <p>13. Inspection Reports – One (1) Original + One (1) copy.</p> <p>14. PVC Calculation and copy of all applicable indices, if PVC applicable. – Two (2) copies</p>
16.	Buying and Paying Authority	<p>A. Packages for which PO is placed by BHEL-PEM Buyer and Paying Authority shall be BHEL-PEM, NOIDA.</p> <p>B. Packages for which PO is placed by BHEL-PSSR & LOA is issued by BHEL-PEM - Buyer and Paying Authority shall be BHEL-PSSR.</p>
17.	Demurrage charges	Demurrage charges shall be paid by supplier/ vendor only to the transporter. No claim shall be acceptable to BHEL in this regard.
18.	Unloading, Storage & Movement of material at site	<p>a. By BHEL site office for supply packages.</p> <p>b. By vendors for Turnkey i.e. Supply and E&C packages</p> <p>Note: The Supplier shall furnish LR wise Gross Wt. of the consignment for the purpose of handling the consignment by BHEL Site Contractor. Please note that unloading of materials at Site may be delayed due to unavoidable reasons. Vendor to inform transporters accordingly. No claim on a/c of delay in unloading shall be entertained. Prior intimation as mentioned in sl. no. 14 above is solicited</p>
19.	Taxes & Duties (For Domestic Vendor)	As per General Conditions of Contract (GCC rev 07)
20.	Taxes & Duties (For Order Directly to Foreign Bidders)	In case of foreign vendors, quoted prices & Dispatches shall be on C & F (Port-Chennai) basis and the Taxes & duties in the country of dispatch shall be borne by Foreign vendor. All the Taxes & duties and other charges applicable in India shall be borne by BHEL unit (PEM or PSSR) which has placed the Purchase Order.
21.	Inspection Agency	BHEL/ BHEL approved 3rd party inspection agencies and/or NTPL/ Customer Agency as applicable.
22.	Inspection procedure	<p><u>For Domestic supplies</u></p> <p>Please refer clause no. 14.0 of GCC Rev 07. Vendor to furnish photographs pertaining to packing of materials before despatch. MDCC shall be issued on the basis of clear inspection report (CQIR).</p> <p><u>For Foreign supplies</u></p> <p>In case of Foreign supplies, if NTPL/ NTPL approved 3rd party inspection agency does not participate in the inspection, test certificates & inspection reports duly accepted by the agreed inspection agency shall be submitted in soft copy to BHEL-PEM. The same shall be reviewed by PEM and then, sent to NTPL for</p>

471144(1)/2021/PS-PEM-BOP

		clearance. The dispatch clearance (MDCC) by NTPL/BHEL as applicable shall be given to the foreign supplier or representative in India after acceptance of above test certificates
23.	Packages for which CIF is available	NIL (Page no 1)
24.	Monthly Progress Report	Vendor to provide monthly progress report each month after placement of PO, till supply of material. Monthly progress report of vendor shall include raw material status, manufacturing, inspection & latest dispatch plan. Vendor may use their format to provide required information, however format (if any) issued by Purchaser after placement of PO shall be obligatory to vendor.
25.	Submission of Final Drgs/ Docs along with O&M Manual, Type Test Certificates (if any)	<p>No. of O&M Manuals</p> <p>As per GCC rev.07/ Technical Specification/Kick-off meeting.</p> <p>If not specified anywhere, Vendor to submit final approved O&M Manual in 10 Hard copies and 4 No of CD ROMs/DVDs/Portable Hard Disk.</p>
26.	Packing, Identification & marking [if not specified in NIT]	<p>Each box/ Drum shall be marked with Capital Letters indicating any one of the following:</p> <p>Main Supply / Mandatory Spares / Commissioning spares / Tools & Tackles</p> <p>Supplies under each of these headings shall be packed separately.</p> <p>Each package / Drum delivered under the Contract shall be marked by vendor as per details listed below and such markings must be distinct and in English language (all previous irrelevant markings being carefully obliterated) for purpose of identification.</p> <p>Each and every box (package) shall be marked with the following:</p> <p>Name & address of the Consignee Name of Project Name of BHEL Unit placing the order Package Name, Vendor Name, LR No. and PO No. & Date. Packing No.: (e.g. 1/10, 2/10, 3/10 when there are 10 packages for one consignment)</p> <p>Packing Mark: Symbols indicating "TOP" and other special markings like "TOP", "BOTTOM", "DO NOT TURN OVER", "KEEP DRY", "HANDLE WITH CARE" etc.</p> <p>Following documents must be put inside the box:</p> <ol style="list-style-type: none"> 01 copy of respective standard manufacturer's erection instruction / O&M manual shall be kept for immediate reference by BHEL site. 01 damage proof copy of Packing List/Challan indicating the items dispatched (with their weights) <p><u>Above instructions are to be read in conjunction with Clause No. 19 of General Commercial Terms & Conditions of GCC rev.07 and those specified in NIT.</u></p>

471144(1)/2021/PS-PEM-BOP

		<p>Notwithstanding anything stated in this clause, Vendor shall be entirely responsible for loss, damage or deterioration of the material due to faulty and insecure packing.</p> <p>Note: Each of the items under mandatory spares shall be tagged with part no. and PO item ref no. /BBU ref no.</p>
--	--	---

