



भारत हेवी इलेक्ट्रिकल्स लिमिटेड



वैश्वेय कुटुम्बकम्  
ONE EARTH • ONE FAMILY • ONE FUTURE

(भारत सरकार के एक उपक्रम)

क्षेत्रीय परिचालन प्रभाग, मुंबई, 14 वें तल, वर्ल्ड ट्रेड सेंटर -1, कफ परेड, कोलाबा, मुंबई-40000

फोन: 022-22171355/ 372/ 301/ 305/ 346/ 354/ 376/ 373/ 375 ईमेल: [mssea@bhel.in](mailto:mssea@bhel.in), [msair@bhel.in](mailto:msair@bhel.in)

संदर्भ संख्या. RE/MUM/IMP/BP/IS-2307

दिनांक: 14.07.2023

प्रति,

एम \_\_\_\_\_  
\_\_\_\_\_

प्रिय मोहदय / महोदया,

विषय: मैसर्स में कारखाने से समुद्री परिवहन के लिए निविदा। हिताची एनर्जी स्वीडन एबी, लुडविका, स्वीडन से न्हावा शेवा तक - **EXW** आधार पर

भारत हेवी इलेक्ट्रिकल्स लिमिटेड एक उर्जा उपकरण विनिर्माण कंपनी है और इंजीनियरिंग माल को निर्यात करना चाहता है। आपके सबसे प्रतिस्पर्धीत प्रस्ताव निम्नलिखित शर्तों पर उपरोक्त विषय के परिवहन के लिए आमंत्रित कर रहे हैं।

निविदा में निम्नलिखित शामिल हैं

- |                             |           |
|-----------------------------|-----------|
| (1) कार्य का क्षेत्र        | - खंड-I   |
| (2) टेंडर्स के लिए निर्देश  | - खंड-II  |
| (3) विशेष - शर्तें          | - खंड-III |
| (4) सामान्य नियम और शर्तें  | - खंड-IV  |
| (5) तकनीकी वाणिज्यिक शर्तें | - खंड-V   |
| (6) दर अनुसूची मूल्य बोली   | - खंड-VI  |
| (7) अनुपालन पत्र            | - खंड-VII |

प्रस्ताव प्रस्तुत करने के लिए दिशानिर्देश:

- निविदा का संचालन और मूल्यांकन जेम पोर्टल के माध्यम से ऑनलाइन किया जाएगा। बोलीदाता अपनी प्रतिक्रिया जेम पोर्टल <https://gem.gov.in> पर निविदा में जमा करके अपनी प्रतिक्रिया प्रस्तुत करेगा।
- सफल बोलीदाता सभी प्रकार से अनुबंध को पूरा करने के लिए जिम्मेदार होगा। जेम पोर्टल के माध्यम से टेक्नो कमर्शियल ऑफर खोले जाएंगे। इस टेंडर को जेम पोर्टल पर ऑनलाइन रिवर्स ऑक्शन के जरिए फाइनल किया जाएगा। बोलीदाताओं से अनुरोध है कि वे ऑनलाइन जेम पोर्टल/सिस्टम के माध्यम से अपने सर्वाधिक प्रतिस्पर्धी मूल्य उद्धृत करें। जेम पोर्टल के संबंध में समर्थन के लिए बोलीदाता निम्नलिखित से संपर्क कर सकते हैं: आर फोन नंबर: 1800-419-3436 ईमेल: [helpdesk-gem@gov.in](mailto:helpdesk-gem@gov.in)। बोलीदाता पंजीकरण जेम पोर्टल में प्रदान की जाती है।

[https://gem.gov.in/training/training\\_module](https://gem.gov.in/training/training_module)

कृपया अंतिम समय की हलचल से बचने के लिए जेम पोर्टल में नियत तारीख से पहले अपना सबसे अधिक प्रतिस्पर्धी प्रस्ताव जमा करना सुनिश्चित करें।

3. प्रस्तावों में शामिल होंगे:

ए। ईएमडी :- **27050/-** रुपये की ईएमडी एनईएफटी/आरटीजीएस के माध्यम से जमा की जानी है। निधि को भेल बैंक खाते में स्थानांतरित किया जा सकता है जिसका विवरण है: नाम: भारत हेवी इलेक्ट्रिकल्स लिमिटेड, बैंक और शाखा: भारतीय स्टेट बैंक, कफ परेड शाखा, खाता संख्या: 10783155482, IFSC कोड: **SBIN00053451**। जीईएम बोली दस्तावेज के अनुसार ईएमडी जमा किया जाना चाहिए। ईएमडी के बिना प्रस्तावों पर मूल्यांकन के लिए विचार नहीं किया जाएगा। यूटीआर विवरण निविदा खोलने से पहले ईमेल के माध्यम से प्रस्तुत किया जाएगा। कोई हार्ड कॉपी डीडी स्वीकार नहीं किया जाएगा।

बी। भाग-1 - तकनीकी वाणिज्यिक बोली। दिए गए दिशा-निर्देशों के अनुसार प्रस्तुत किया जाना चाहिए।

सी। भाग-2 - मूल्य बोली। दिए गए दिशा-निर्देशों के अनुसार प्रस्तुत किया जाना चाहिए।

भेल कार्यालय में निविदा दस्तावेजों की कोई हार्ड कॉपी स्वीकार नहीं की जाएगी।

सुभ कामनाएं

भारत हेवी इलेक्ट्रिकल्स लिमिटेड के लिए

प्रबंधक (आयात)

सहपत्र: अनुबंध के खंड-I से VII

सहपत्र: अनुबंध के खंड-I से VII



## Bharat Heavy Electricals Limited

(A Government of India Undertaking)

### Regional Operation Division,

14-15<sup>TH</sup>, Floor, World Trade Centre-1, Cuffe Parade, Colaba, Mumbai -400005.

Phone:022-22171355/ 372/ 301/ 305/ 346/ 354/ 376/ 373/ 375 Email : [mssea@bhel.in](mailto:mssea@bhel.in), [msair@bhel.in](mailto:msair@bhel.in)

No. RE/MUM/IMP/BP/IS-2307

Date: 14.07.2023

To

M/s \_\_\_\_\_  
\_\_\_\_\_

Dear Sirs,

**SUB: Tender for Sea transportation from factory at M/s. Hitachi Energy Sweden AB, Ludvika, Sweden to Nhava Sheva - on EXW basis**

BHEL, a Power Equipment Manufacturing Company, intends to import Engineering cargo. Your most competitive offer is invited for the subject transportation on the following terms and conditions.

The tender comprises of:

Sr No	Description	Section
1	Scope of Work	I
2	Instructions to Bidders	II
3	SPECIAL CONDITIONS	III
4	General Terms and Conditions	IV
5	Format for PQR & Techno Commercial Conditions	V
6	Format for Price BID	VI
7	Letter of Compliance	VII

### **GUIDELINES FOR OFFER SUBMISSION:**

- The tender will be conducted and evaluated online through GeM portal. The bidder shall submit his response through bid submission to the tender on GeM platform at <https://gem.gov.in>.
- Successful bidder shall be responsible for completion of the contract in all respects. Techno commercial offers shall be opened through the GeM portal. This tender will be finalized through online Reverse Auction on GeM platform. Bidders are request to quote their most competitive prices through the online GeM portal. For support regarding GeM system, bidders may contact following: GeM customer support team, Tele No: 1800-419-3436 Email ID : [helpdesk-gem@gov.in](mailto:helpdesk-gem@gov.in). Bidder registration procedures are provided in the portal [https://gem.gov.in/training/training\\_module](https://gem.gov.in/training/training_module). **Please ensure the submission of your most competitive offer before the due date in the GeM Portal to avoid last minute hustle.**
- The offers shall Include:
  - The EMD of **27050/-** to be submitted through NEFT/RTGS. The fund may be transferred to the following account. **Company Bank Account details: NAME : Bharat Heavy Electricals Limited, Bank & Branch: State Bank of India, Cuffe Parade Branch, Account No : 10783155482 IFSC Code: SBIN0005345.**

EMD must be deposited as per GeM bid document. The offers without EMD will not be considered for evaluation. UTR details shall be furnished vide email before opening of tender. NO hard copy DD shall be accepted.

  - Part-1 – Techno Commercial Bid. Should be submitted as per guideline provided.
  - Part-2 – Price Bid. Should be submitted as per guideline provided.

**NO Hard copies of Tender Documents will be accepted at Company Office.**

Thanking you,  
For Bharat Heavy Electricals Limited

Manager (Import)  
Encl: Section-I to VII

# CONTENTS

<b>Section I</b>	:	General Information and Scope Of Work
Section II	:	Instructions to Bidders
<b>Section III</b>	:	Special Conditions
<b>Section IV</b>	:	General Terms and Conditions
<b>Section V</b>	:	Format for PQR and Techno Commercial Conditions
<b>Section VI</b>	:	Format for Price Bid
<b>Section VII</b>	:	Letter of compliance

**Section I**  
**General Information**

**Important Details of the Tender**

<b>Name and Contact Details of the Person for Queries in the Tender</b>	1]Mr. Vishnu Waradkar, Executive Ph:022-22171372,Mo: 8779669958, <a href="mailto:varadkar@bhel.in">varadkar@bhel.in</a> 2]Mrs. Surbhi Aggarwal, Manager Ph:022-22171355,Mo:7506645314, <a href="mailto:surbhi@bhel.in">surbhi@bhel.in</a> 3] Mr. Sanjeev Shikhare, AGM (MS) Ph: 022-22171301, <a href="mailto:rodsds@bhel.in">rodsds@bhel.in</a>
<b>EMD Amount</b>	Rs 27500/- (As per GeM GTC Cl 4.xiii(m))
<b>Last Date of Submission of EMD</b>	As per tender due timeline in GeM bid document
<b>Last Date of Submission of the Tender in GeM portal</b>	As per GeM bid document
<b>Due date of tender opening (technical bid)</b>	As per GeM bid document

		<b>Supply</b>	
<b>Cargo Description</b>		DC-Bushing – 400 KV – ( 3 nos)	
<b>Imports From:</b>	<b>Exworks :</b> Factory at M/s. Hitachi Energy Sweden AB, Power Transformers, Torg 12, Dep. PGTR/PTPS, 77180 Ludvika, Sweden	<b>Discharge Port :</b>	Nhava Sheva, India
<b>FOB Readiness of cargo</b>		<b>Ready (25.06.2023)</b>	
<b>Supplier's Address</b>		Hitachi Energy Sweden AB, Power Transformers, Torg 12, Dep. PGTR/PTPS, 77180 Ludvika, Sweden	
<b>Supplier Contacts</b>		<b>Kerstin Romlin</b> Power Transformers, Projekt Support Valhallavaegen 2 Main office; Transfomers Ludvika 771 80, Dalarnas Lan, Sweden Phone: +46107383074 Mobile: +46767783074 E-mail: kerstin.romlin@hitachienergy.com <a href="http://www.hitachienergy.com">www.hitachienergy.com</a>	
<b>Value of cargo</b>	<b>PO no.</b> RE- IMPORT	<b>Value in SEK</b> 1413000	
<b>Bhopal Unit Contact</b>		Pranav Mahajan em: <a href="mailto:pmahajan@bhel.in">pmahajan@bhel.in</a> , No : +91- 9425604868/ 0755-2505690	
* <b>Shipment to be done in FCL- Ex- Work factory at M/s. Hitachi Energy Sweden AB, Ludvika, Sweden as per packing list</b>			
* <b>Shipment to be done in 2 x 40 FT DC/HC containers as per packing list in 1 BL</b>			

**Scope of Work:****Packing List for Supply - factory at M/s. Hitachi Energy Sweden AB, Ludvika, Sweden:**

Item description	Gross Wt	Length	Width	Height	CBM	No of pkgs	Remark	Packages Description
	KGs per package							
DC-Bushing – 400 KV	3240	920	110	135	40.986	3 Wooden Box	Non-Hazardous Non Stackable Non - Tilttable	Wooden Box
Total Wt. for 3 package	9720				40.986	3		

\*No minimum Load is guaranteed. Payment will be done on number of containers freighted.

## Cargo to be shipped in containerized mode

### Important notes:

- **Non BHEL Consignment is not to be clubbed in BHEL container**
  - **The above packing list is tentative and may vary at the time of shipment.**
  - The consignments are to be shipped in FCL Basis.
  - The shipment is ready.
  - Final confirmation and co-ordination to be done with the shipper before pick up.
  - All efforts to be made for early pick up of the shipment.
- **Final BL to be issued after getting confirmation on draft BL from Supplier.**
- **Bidder has to make shipping arrangements from Gothenburg port from where the earliest vessel/containers is/are available.** Shipper will handover cargo on EX-Work Basis – at factory i.e at M/s. Hitachi Energy Sweden AB, Ludvika, Sweden. The transportation of cargo/containers to the load port has to be done by the bidder without claiming any additional costs.
- Contractor to get approval of loaded container from shipping line in advance. Contractor to provide photo of loaded container showing cargo/stuffing arrangement and its choking, lashing etc. final Container loading plan for package stuffed should be shared with company after vessel sailing.

The contractor / his Load Port agent should establish contact with our Supplier / his agent and make necessary shipping arrangements as soon as Letter of Award (LOA) is placed

The Final arrangements to be made by the contractor only after proper coordination / confirmation from our supplier. The contractor to ensure that cargo/stuffed container is available at Load Port before vessel arrival to avoid "Dead Freight".

BHEL will not be liable for dead freight or any other related penalty, detention or demurrage.

### Scope of Work:

- 1 The cargo is being re-imported after testing and the serial no. and net weight should match with Export documents.
- 2 Supplier will arrange to hand over cargo to the contractor at his factory on EX-WORK basis, at M/s. Hitachi Energy Sweden AB, Ludvika, Sweden.
- 3 Contractor will place transport and arrange pick up from EX-Works Location to Gothenberg Load Port. It is contractor's responsibility to co-ordinate with supplier for all these arrangements after confirming the readiness of the cargo from supplier, stuffing, lashing, etc as required.
- 4 **All ex-works activities like pick up of cargo from shipper's warehouse, loading in to Containers/ Trucks placed by forwarder, transportation to the warehouse, stuffing, lashing, choking and securing the cargo in the containers, required customs clearance, origin charges, etc (all activities at origin is to be done by the forwarder).**
- 5 Contractor will carry out necessary custom clearance at load port. Contractor will co-ordinate with our supplier for necessary documentation for custom clearance.
- 6 **Custom duty, if applicable, at load port will be payable at actuals through reimbursement by company to the contractor. For the purpose of conversion from SEK/ EUR to INR, the SBI TT selling rate prevailing on the date of duty payment as mentioned in the shipping bill/ duty payment challan will be considered. In case there is a bank holiday on the date of Bill of Lading, then the rate prevailing on the previous working day will apply.**
- 7 Vessel arrangements at Load Port for ocean freighting of the cargo to Nhava Sheva.
- 8 All the load port dues will be payable by contractor.
- 9 Contractor shall arrange the proof of receiving cargo from supplier with date
- 10 Safe Discharge of all the loaded container/ cargo at Discharge Port.
- 11 The supplier will hand over cargo to contractor. If contractor is unable to arrange the vessel after receiving the cargo from supplier at origin, the storage charges if any will be to contractor's account.

- 12 **BHEL will not pay DEAD Freight / vessel detention/ hook idle/ port storage at load port/origin under any circumstances.**
- 13 Contractor to ensure that IGM is filled as per latest SCMTR guidelines before the arrival of containers at Nhava Sheva so that BHEL is in position to file prior Bill of Entry at customs.
- 14 **Draft BL** has to be forwarded to BHEL in 7 working **days** in advance of vessel arrival at load port for approval. Final BL to be issued by Forwarder to Shipper only after getting confirmation on draft BL from BHEL/ shipper, and is to be handed over within 3 working days of sailing of vessel.  
In case BHEL incurs any detention, demurrage, storage, penalty, interest or any other losses due to late handing of the OBL, the same will be recovered from Forwarder Bills.
- 15 Evidence of date of receipt of shipping documents from supplier (for their freight forwarder) to be provided by contractor to BHEL.
- 16 Contractor to provide 15 days of container detention free period at Nhava Sheva. Detention charges if applicable, after the free period of 15 days shall be paid as per the line's published tariff. The detention incurred if any, is to be paid by the forwarder and take reimbursement against shipping line invoice at actuals, with supporting published tariffs. **No DO Revalidation charges, if any charged by the lines will be payable.**
- 17 Cargo arrival notice along with ETA of the vessel at discharge port is to be communicated by the contractor in 15 days advances to BHEL / BHEL appointed CHA. Pre-alert through email should be given as soon as final B/L is issued.
- 18 The contractor shall furnish **prior IGM/item details** & copy of Freight bill details at least 7 days before arrival of vessel at discharge port to enable BHEL to file B/E at customs
- 19 The contractor shall arrange for single window final delivery order from his office within 02 days of final IGM (inward date) /submission of OBL, whichever is later. DO will be handed over to BHEL's authorized CHA at his port office by contractor (in case of manual DO) or online. Any charge incurred due to any delay by contractor in handing over final delivery order shall be recovered from contractor bills.
- 20 Contractor shall liaison with shipping line in resolving IGM error/amendment within five working days. Any detention/ demurrage/ penalty incurred due to wrong IGM will, late IGM amendment will be to the account of the forwarder.
- 21 The contractor should provide the details of their load port agent immediately **within 7 working days of receiving the LOA** to enable BHEL to amend the LC incorporating the agent details. Any charge incurred towards LC amendment due to any delay accountable to contractor shall be recovered from contractor.
- 22 **Upon Safe discharge of container at discharge port, the contractor shall ensure the handover of necessary documents to enable movement of BHEL container to BHEL nominated CFS (DPD + CFS) (at presently JWC Logistics Park Pvt. Ltd, may check with BHEL for the current nominated CFS before movement) IGM Code: Custom EDI Code - INNSA1JLP1, Port Code (1) JNPT Port: JWC (2) GTI Port: JWC (3) NSICT Port: NSAJWC without any financial liability to BHEL.**
- 23 Any non-specific service item, which is necessary for satisfactory completion of the work under the scope but not specified here, shall be deemed to be included in the scope of work at no additional cost to BHEL.
- 24 Description of work mentioned above is illustrative and not exhaustive and they will have to consider all incidental works if involved while conducting the job in giving their rates. No incidental/additional charges will be payable for any other miscellaneous works connected with the handling of above jobs
- 25 Detailed Instructions, terms and conditions are covered in Section II, III, and IV & V of this Tender document. Bidders are requested to carefully read these sections.

Seal of the Company & Date

Signature & Name of Contractor

## **SECTION II**

### **INSTRUCTIONS TO BIDDERS**

Bidders are advised to go through the tender document fully before submitting their offers online on GeM Portal:

- 1.0 Bidders are advised to go through the tender document fully before filling up the format for Techno-commercial Section and Price bid Section
- 2.0 The bidder must submit the total offer and the details desired therein. The offers which are not complete or mentioning "shall be furnished later" will be rejected.
- 3.0 The bidder while submitting the offer should consider the **shortest, most economical and reliable logistics** to be adopted for transportation of cargo.
- 4.0 The price offer must be made only in the Price Bid formats enclosed with this tender.
- 5.0 The offers shall be kept valid for a period of 45 days from the date of opening of the tender.
- 6.0 BHEL reserves the right to accept any tender or part of tender or to reject all tenders without assigning any reasons thereof. It shall be responsibility of the contractor that their agents ensure proper working of the offers in the interest of BHEL and the contractor shall be fully responsible for acts and deeds of the agent.
- 7.0 No modifications to the work contained in the items will be allowed. Quotations other than in prescribed Price Bid formats will not be accepted under any circumstances.
- 8.0 No clarification or modification to the specifications, item, descriptions, scope of work and other tender terms and conditions is to be enclosed. Any such clarification/modification if enclosed in the offer will be totally ignored and such bids will be rejected. No corrections to be made to the price bid.
- 9.0 Any request from the bidders in respect of additions, alternations, modifications, corrections etc. of either terms or conditions, or rates of his offer after opening of the tenders shall not be entertained.
- 10.0 The acceptance of tender shall be intimated to the successful bidder through a Letter of Award (LOA). The contractor shall be required to submit security deposit as per the Tender document, within **five working days (excluding bank holidays)** of issue of LOA, which should be valid up to 3 months after the expiry of the contract period as specified in the Letter of Award. In case of delay in submission of security deposit, enhanced security deposit which would include interest (SBI rate + 6%) for the **delayed period**, shall be submitted by the bidder. Further, if security deposit is not submitted till such time the first bill becomes due, the amount of security deposit due shall be recovered, from the bills along with due interest
- 11.0 **Evaluation criteria**
  - 11.1 The offer of parties meeting the Technical requirements will only be considered for evaluation.
  - 11.2 The offers will be evaluated on the basis of the total value offered in the Price Bid.
  - 11.3 The Tender will be finalized through Reverse Auction only on GeM portal itself. Bidders who are technically not qualified will not be allowed to participate in the reverse auction. Bidder must fill all the schedules and Price for each and every items. If the bidder fails to quote any of the items in Price Bid, he will be disqualified and will not be allowed to participate in Reverse Auction.
- 12.0 **Instruction for MSE Suppliers (Micro and Small Enterprises): As per GeM portal General Terms and conditions.**
- 13.0 **Bidder to submit the final price breakup on pro-rata basis as per Price Bid (Section VI) within the same day of completion of RA.**

Seal of the Company & Date

Signature & Name of Contractor

**SECTION III**  
**SPECIAL CONDITIONS**

- 1.0 **Transit Time**
- 1.1 Total Transit time permitted = 60 **Days** (Inclusive of Shipped on board as well as IGM inward date (as per ICE GATE/ BOE)
- 1.2 **Start of Transit time** will be the date of receipt of cargo and documents at the factory as mentioned whichever is later.
- 1.3 **End of Transit time** will be the date to final IGM (inward date - (as per ICE GATE/ BOE)) of shipment lot at JNPT Nhava Sheva Port
- 1.4 The contractor has to pick up the cargo within 14 days of readiness of the cargo.
- 1.5 Vessel details to be informed to Supplier at least 21 days prior to the arrival of such vessel at load port.
- 1.6 If the contractor has failed to arrange pick up within 14 days of shipper's intimation / LOA date / LC amendment date whichever is later, **then the transit time will start** from 31<sup>st</sup> day from shipper's intimation / LOA date / LC amendment date whichever is later.
- 1.7 BHEL reserves the right to invoke Risk Purchase clause 10.0 of section IV as per General terms and conditions.
- 2.0 **Transit Penalty:** The transit delay beyond the permitted transit period shall attract a penalty of 1% per day on the ocean freight value excluding GST for the shipment subject to maximum of 10% of the total ocean freight of the shipment lot.
- 3.0 **Vessel Qualification:**
- 3.1 Cargo should be carried by mechanically self-propelled vessels of steel construction classed with classification society which is:
- 3.1.1 a member of associate member of International Association of classification societies(ICAS) or
- 3.1.2 A national flag society as defined below, but only where vessel is engaged exclusively in coastal trading of that nation (including trading on an inter-island route within an archipelago of which the nation forms part)
- 3.1.3 For the list of Current IACS Members and associate members refer to the IACS website at [www.iacs.org.uk](http://www.iacs.org.uk)
- 3.2 Shipment by unclassified vessel is prohibited.
- 4.0 **Age limitation of vessel:**
- 4.1 Cargoes and/or interests carried by Qualifying Vessels (as defined above) which exceed the following age limits will be insured on the policy or open cover conditions subject to an additional premium to be agreed with underwriter.
- 4.2 Bulk or combination carriers over 10 years of age or Other vessels over 15 years of age unless they:
- 4.2.1 have been used for the carriage of general cargo on an established and regular pattern of trading between a range of specified ports, and do not exceed 25 years of age, or
- 4.2.2 Were constructed as containerships, vehicle carriers or double-skin open-hatch gantry crane vessels (OHGCs) and have been continuously used as such on an established and regular pattern of trading between a range of specified ports, and do not exceed 30 years of age.
- 4.3 The contractor must submit a compliance certificate from shipping company / agent confirming compliance of these requirements for Bill of Lading.
- 5.0 **National Flag society:** A national flag society is a classification society, which is domiciled in the same country as the owner of the vessel in question, which must operate under the flag of that country.
- 6.0 Suitable Vessel selected for freighting of the cargo is to be in line with Institute Classification Clause 01//01//2001
- 7.0 All taxes, charges and dues of vessel if any during execution of this contract shall be on contractor's account both in load port and the discharge port
- 8.0 Stevedoring charges if any at both load port and discharge port shall be on contractors account.
- 9.0 **Payment Terms**
- 9.1 100% payment as per Price Bid in Indian Rupees will be made by BHEL, ROD, Mumbai after adjustment of penalty, TDS, GST TDS, other deductions, if any, **within 45 working days of** release of Delivery order or bill submission whichever is later.

- 9.2 Vessel qualification, age and type certification should be submitted along with the bill as per Section III.
- 9.3 Bidders should quote in Prescribed Price Bid Format only. Prices are to be quoted by bidders inclusive of all taxes, levies etc.
- 9.4 If any new tax in India is introduced by Central/ State Govt, etc., and becomes directly applicable on items specified in the price bid, full reimbursements shall be made provided it becomes applicable on items specified in the price bid.
- 9.5 Price quoted by vender shall be deemed to be inclusive of any taxes, duties charges etc (if any) leviable outside the country. No variation shall be allowed due any change in taxes, duties, charges etc. outside India.
- 9.6 No interest will be payable by BHEL in case of delay in payment due to some unavoidable circumstances.
- 9.7 **Custom duty, if applicable, at load port will be payable at actuals through reimbursement by company to the contractor. For the purpose of conversion from SEK/ EUR to INR, the SBI TT selling rate prevailing on the date of duty payment as mentioned in the shipping bill/ duty payment challan will be considered. In case there is a bank holiday on the date of Bill of Lading, then the rate prevailing on the previous working day will apply.**
- 10 The order will be placed on only one party due to operational exigency / efficiency.**
11. The **documents to be submitted along with bills in duplicate** (Also one soft copy to be provided) are as follows:
1. Contractors Invoice duly signed and stamped as per the Price bid Schedule (**digitally signed invoice with IRN/ QR code as per norms to also be submitted**)
  2. Final suppliers Packing list.
  3. BL copy with shipped on board date.
  4. Vessel qualification / age/class certificate.
  5. Shipper's intimation of readiness (Email copy).
  6. Factory ( Ex- Work) Pick- up receipt of cargo with date time and sign
12. Company shall be resorting to Reverse Auction (RA) on GeM for this tender. RA shall be conducted among the techno-commercially qualified bidders. GeM rules will apply for RA.
13. If the supplier/situation demands for additional container for the tendered/additional cargo, then the same contracted rates will apply. Requirement of additional container should be immediately brought to the notice of BHEL and booking of container/shipment will be kept in abeyance till then. If 20' container is used in place of 40' then 50% of freight of 40' will be paid for 20' container.
- a. Container arranged should be a seaworthy, sound and good quality container.
  - b. Contractor should make available survey report of empty containers made before shipment wherever required.
  - c. Contractor has to ensure that the containers has clear CLC /CSC Plate.
  - d. Container should conform to the standards of the Convention for Safe Containers 1972 (CSC) and IMO/CSC.1/Circ.138.
  - e. The container used should have clearly mentioned CSC Certification No., Customs/Transport No., Manufacture Type, Manufacturer name, Manufacture Date, ISO code.
  - f. If container arrives in damage condition damage charges of shipping will be paid by contractor or will recovered from his bills.
14. Stevedoring charges if any at both load port/transit port and discharge port shall be on contractors account.
15. Photos of cargo with date before loading should be taken and provided to us on email/whatsapp etc.

Seal of the Company & Date

Signature & Name of Contractor

**SECTION IV  
GENERAL TERMS AND CONDITIONS**

The following terms shall have the meaning hereby assigned to them except where the context requires otherwise: -

- 1.1 "COMPANY" shall mean Bharat Heavy Electricals Limited, in short BHEL, a Company registered under Indian Companies Act 1956, with its Registered Office at BHEL House, Siri Fort, New Delhi-110 049, India and includes a duly authorized representative of the Company or any other person empowered in this behalf by the Company to discharge all or any of its functions.
- 1.2 "CONTRACTOR" / "VENDOR" / "BIDDER" shall mean the individual, or Firm who enters into this Contract with BHEL and shall include their executors, administrators, successors and assigns. "CONTRACTOR" shall also mean "AGENT" or "CARRIER" or "TRANSPORTER", "MTO" or "CFS" or "FREIGHT FORWARDER or CONSOL AGENT OR CHA where the context so requires.
- 1.3 "SITE" shall mean the place or places, including Project store at which the Cargo/ equipment are to be delivered and services are to be performed as per the specification of this tender.
- 1.4 "CONTRACT" or "CONTRACT DOCUMENT" shall mean and include the agreement, LOA, the work order, the accepted appendices of rates, Schedules of Quantities (if any), General Terms and Conditions of Contract, Special Conditions of Contract, Instructions to Bidder, the drawings, the Technical Specifications and the Special Specifications (if any) and all correspondence.
- 1.5 Any conditions or terms stipulated by the bidder in the tender documents or subsequent letters shall not form part of the Contract unless specifically accepted in writing by Company and incorporated in the Agreement.
- 1.6 "TENDER SPECIFICATIONS" shall mean the Scope of Work, Special Instructions / Conditions, Technical specifications/requirement, Appendices, Site Information and drawings pertaining to the work and any other relevant reference in the Tender Document for which the Bidder are required to submit their offer.
- 1.7 "APPROVED" "DIRECTED" or "INSTRUCTED" shall mean approved, directed or instructed by Company.
- 1.8 "SINGULAR AND PLURAL" etc. words carrying singular number shall also include plural and vice versa, where the context so requires. Words imparting masculine gender shall be taken to include the feminine gender and words imparting persons shall include any Company or Association or Body or Individuals, whether incorporated or not.
- 1.9 "VALIDITY OF THE CONTRACT". The contract will remain valid till completion of scope of work for all cargos which are handed over/ received / reported at designated place within date specified in other terms and conditions of this tender inclusive of extensions if any. Where validity date is not specified, the contract will remain valid till all the activities specified therein are completed in all respects to the satisfaction of Company or where the Company has decided to modify (increase/reduce) the scope of work, on completion of such modified scope of work to the complete satisfaction of Company.
- 1.10 "COMPLETION OF THE CONTRACT" The contract will be treated as complete on full and final settlement of all Bills / invoices raised under the contract with no claim on either side.
- 1.11 "Ton" means one metric Ton of 1,000 kilograms or one cubic meter.
- 1.12 "Full Container Load" (FCL) shall mean a container containing cargo belonging to one consignee in the vessel's manifest.
- 1.13 "LCL" means Less than Container Load wherein part of the imported cargo contained in the container belong to a particular customer/importer.
- 1.14 FREIGHT TON (FRT): Shall mean Cargo weight in Metric Tons or volume in cubic meter whichever is greater.

- 1.15 HEAVY LIFT (HL): Shall mean any one Cargo package of equipment and/or materials with weight greater than or equal to 100MT.
- 1.16 OVER DIMENSIONAL CARGO (ODC): Shall mean any one Cargo package of equipment and / or materials with any one of the dimensions exceeding those for General Cargo.
- 1.17 GENERAL CARGO: Shall mean any one Cargo package of material and /or equipment with a weight less than 100 MT and with all dimensions equal to or below 13m Length, 3m Width, 3m Height (13mx3mx3m).
- 1.18 "IGM" means import general manifest.
- 1.19 LOT: Supplies which are shipped on single voyage/Flight of each vessel/Barge/Aircraft.
- 1.20 PROJECT CARGO: Shall mean any cargo comprising of equipment, fabricated items, and components of the manufactured equipment / system of: Mechanical, Electrical, Instrumentation & Control, Electronics, Metal structures / pipes, Large/ Heavy Engineering machinery, transformer oil, Resins, insulation material, hardeners etc or a mix thereof, Items used in power plants, transported as a containerized shipment and breakbulk shipment during the course of national or international transportation or exportation-importation.
- 1.21 Non Heavy Lift Cargo means General cargo and ODC i.e. cargo that does not fall under definition of heavy lift.
- 1.22 Nhava Sheva ports means all the 5 terminals in the port, i.e., JNPCT, NSICT, NSIGT, BMCT & GTI and any other terminal/CY that may be developed in JNPT.
- 1.23 The word 'container' would mean either a twenty feet equivalent unit (TEU) or a forty feet equivalent unit (FEU) as the case may be.

**2.0 Issue of Notice:**

- 2.1 The Contractor shall furnish the name, designation and addresses of his authorized agents/associates at Mumbai (India), at the Discharge Port and or at the CFS yard. All complaints, notices, communications and references shall be deemed to have been duly given to the Contractor, if delivered to the Contractor or his authorized agent/representative.

**3.0 Commencement of Work:**

- 3.1 The Contractor shall commence the work on specific intimation from Company in writing or the time indicated in the LOA and shall proceed with the same with due expedition without delay. If the contractor fails to commence the work as per the terms of Order/Contract, Company, at its sole discretion will have the right to cancel the Order/Contract. His Earnest Money and/or Security Deposit will stand forfeited without prejudice to any and all of Company's other rights and remedies in this regard.

**4.0 DISCREPANCY AND CONTRADICTION**

- 4.1 The several documents forming the contract are to be taken as mutually explanatory of one another. In case of any contradiction in the terms and conditions as specified in the Special Conditions of Contract and General Conditions of Contract, the Special Conditions will prevail over the General Conditions of contract.
- 4.2 In case if the contradiction in the Tender terms and conditions could not be resolved on the above basis, UNIT HEAD-ROD BHEL or his authorized representative shall be the deciding authority with regard to intention of the contract.

**5.0 ARRANGEMENT OF SHIP//TRUCK/TRAILOR/AXELS:**

- 5.1 The Bidder shall arrange the vessel i.e. ship(s)/ (s)/ Truck(s)/ Trailer(s) /Axel(s) on specific intimation(s) from Company in writing or the time/schedule indicated in the LOA/Work order/Contract without delay. If the Bidder fails to do the same as per the terms of Order/Contract, Company, at its sole discretion will have the right to cancel the Order/Contract. His Earnest Money and/or Security Deposit will stand forfeited without prejudice to any and all of Company's other rights and remedies in this regard.

- 5.2 Before arrival of the vessel, the Bidder will inspect the cargo available in Port whether under the custody of the Bidder or Company or its supplier or any other authorized representative and ensure its sea worthiness. Any deficiency in this regard shall be brought to the notice of Company in writing suggesting remedial measures to enable Company to make it sea worthy. Alternatively, such action can be taken by the Bidder after obtaining written approval of Company to the action as well as to the cost. Such cost incurred by the Bidder shall be reimbursed by Company to the Bidder, if agreed. After such remedial measures, the Bidder shall be responsible for loading of the cargo on the Ship arranged by the Bidder.
- 5.3 The Bidder shall also intimate Company in writing about the documents required for loading of the cargo on the vessel. He will be responsible for examination of all the required documents before arrival of the vessel and any discrepancy in the same shall be attended to by the Bidder /Company in time to ensure loading on the vessel arranged by the Bidder as per cl.5.1 above.
- 5.4 Contractor should use vessels having good track records of timely delivery.

**6.0 DETENTION OF THE CARRIER:**

- 6.1 It will be the responsibility of the Bidder to ensure that all the declared and available cargo is loaded on the vessel and unloaded from the vessel in time without its detention. The Bidder shall be fully responsible for detention of the vessel and Company shall in no way be liable to pay any detention charges whatsoever.
- 6.2 In case of non-availability of vehicles etc to receive cargo directly from Vessel on its arrival at port, the detention charges of stoppage of vessel at port will have to be borne by the bidder.
- 6.3 For unloading of cargoes on to wharf, the availability of Hydraulic axles is essentially required at the time of arrival of vessel. Due to non-availability of required trailers/tools & equipment's, the trucking & terminal handling charges will be to bidder's accounts

**7.0 License/Permission/Registration:**

- 7.1 Wherever any License /Permission from or Registration with Local or State or Central authorities is required under the above Acts/Law or any other Laws Governing the work contracted for, the Bidder shall at his own cost arrange for such License/ Permission/ Registration. Bidder shall also be liable for producing for inspection such certificates and licenses as may be required by the Local/State/Central Authorities or Company as and when required. The Bidder shall pay all levies, fees, taxes and charges etc. to appropriate authorities and other bodies as required by them under their rules for, vehicles / trailers, employees or workers engaged by him. These charges shall be borne by the Bidder. The vehicle/trailer shall not carry load in excess of the Gross Vehicle Weight as mentioned in the RC Book of the vehicle/trailer concerned. No claim or compensation for reimbursements, made against Company by Bidder shall be entertained by Company for any breach of the provisions/Acts or laws by the Bidder.
- 7.2 In case of Risk Purchase is enforced, The Bidder will hand over the clean cargo along with all related documents, NOC etc. without any financial bearing to Company, enabling Company/Company nominated freight forwarder to carry out the work further.
- 7.3 It shall be the duty of the Bidder to acquaint himself with all safety regulations regarding handling equipment and Road Transportation of all types of containers/cargo. The Bidder shall follow the safety requirements mentioned here and as applicable by laws, rules and regulations all the time during the period of contract.
- 7.4 The Bidder shall indemnify Company against any violation of safety laws, rules and regulations while carrying-out operations as required by the contract.
- 7.5 No unauthorized person should be allowed to work on the Trailers/equipment etc. The drivers and crane operators should have valid license and should be proficient in their work. No person without a valid driving license should be allowed to drive the vehicle.

**8.0 Invoices and Payments:**

- 8.1 The Contractor will be required to raise the Invoice for the services rendered. The Invoices will have to be raised according to the explicitly agreed rates and payment terms of the contract.
- 8.2 All the Bills like Freight Bills, THC, etc must be in the name of BHEL, ROD Mumbai having GSTIN as 27AAACB4146P1ZF.
- 8.3 If contractors invoice is not in the name of "BHEL, ROD Mumbai", the GST will not be reimbursed to the contractor as Company will not be in a position to avail GST credit.
- 8.4 Contractor should timely update output data in GST portal to enable Company to take input tax credit. GST of the contractor will be released only on correct reflection of the invoice and amount of GST portal.
- 8.5 Freight payments along with the other charges as per the contract rates shall be made to the contractor in Indian Rupees only. For the purpose of conversion, the SBI TT selling rate prevailing on the date of Bill of Lading will be considered. In case there is a bank holiday on the date of Bill of Lading, then the rate prevailing on the previous working day will apply. Freight bill shall contain the details of packages, weight and MBL number and other charges as per the contracted rates.
  - 8.5.1 100% payment of the charges will be made by Company by NEFT / RTGS against the bill submitted with all documents as per payment terms.
  - 8.5.2 Payment of the amount claimed will be arranged after necessary checks of the correctness of the claim, deducting all charges/ penalties / damages / fines / recoveries due, **including TDS / GST TDS** and/or any other levies at the prescribed rates.
  - 8.5.3 Reimbursement of charges paid by the forwarder like detention/storage etc. will be made against submission of proper and correct GST invoices and bills along with applicable tariff, within 45 days of receipt of such bills. Invoices if issued in the name of BHEL will have to be submitted in original with correct GST nos. for claiming the reimbursement.
  - 8.5.4 Contractor shall issue CAN (Cargo arrival notice) immediately on filing of prior entry IGM by the Liner/ Carriers.
  - 8.5.5 TDS / GST TDS as applicable will be deducted from contractor's bill.
  - 8.5.6 All the bills should be submitted in duplicate i.e one original and one copy. In addition, one scan copy bill is also to be shared.
  - 8.5.7 All taxes, charges and dues of vessel if any during execution of this contract shall be on Contractor's account both in load port and in the discharge port.
  - 8.5.8 Wherever freight is claimed on weight/CBM, Packing List issued by Supplier will be considered for final payment.
  - 8.5.9 GST as applicable to be included in price. Contractor should ensure that original invoice/ bill/ receipt in the name of Company is provided at the time of payment.
  - 8.5.10 Payment will be made against NEFT/ RTGS details mentioned in the bank e-mandate certified copy.

**9.0 Time Limit for Submission of Bills:**

- 9.1 The contractor shall make a claim for the services rendered under this contract to Company within (3) Three months of such service. If he does not prefer claim within the said period, he shall be deemed to have waived his right in the respect thereof and shall not be entitled to any payment on account thereof. Nevertheless, the accepting authority on written request can waive off this limitation and allow late submission of bills if the reasons for delay are found convincing and reasonable.
- 9.2 No claim in respect of under payment to the contractor shall be considered valid or entertained unless a claim in writing is made thereof within (4) four months from the date on which payment of the original claim thereto was made. Any claim for such under payment, not received within the stipulated three month's period, shall be liable to be summarily rejected by Company.

Nevertheless, the accepting authority on written request can waive off this limitation and allow late submission of bills if the reasons for delay are found convincing and reasonable.

**10.0 Risk Purchase:**

- 10.1 Company reserves to itself the following rights in respect of this Contract without entitling the Contractor for any compensation.
- 10.2 If at any time during the execution of the contract, the contractor fails to render all or any of the services required under the scope of work of the contract satisfactorily in the opinion of Company, whose decision shall be final and binding on the contractor, Company reserves the right to get the work done by other parties or departmentally at the cost and risk of the contractor and also forfeit the security deposit.
- 10.3 To recover any amount due from the Contractor, from any amount due to the Contractor under this or any other contract or from the Security Deposit.
- 10.4 The Company reserves the right to terminate the contract of any contractor at any time, without assigning any reasons thereof, **by giving 5 days' notice of their intention** to do so in writing to the contractor who shall not be entitled for any compensation by reason of such termination
- 10.5 To claim compensation for losses sustained including Company's supervision charges & overheads in case of termination of Contract.
- 10.6 In case of Risk Purchase is enforced, the contractor will hand over the clean cargo along with all related documents, NOC etc without any financial bearing to Company, enabling Company/Company nominated Contractor to carry out the work further.

**11.0 Observance of Local Laws:**

- 11.1 The Contractor shall comply with all Laws, Statutory Rules, and Regulations etc. The Contractor shall obtain all necessary permits/approval from the local Governing Body, Police and other concerned Authorities as may be required under law.
- 11.2 The Contractor shall pay all taxes, fees, license charges, deposits, duties, tolls, royalty, commissions or other charges that may be leviable /levied on account of any of the operations connected with the execution of this contract.
- 11.3 The Contractor shall be responsible for the proper behavior and observance of all regulations by the staff employed.

**12.0 Safety of Men, Equipment, Material & Environment:**

- 12.1 All safety rules, codes applied by Company/its customer at port/CFS/ICD shall be observed by the Contractor and his workmen without exception. The Contractor shall be responsible for the safety of the equipment/materials and work to be performed by him.
- 12.2 It shall be the duty of the contractor to acquaint himself with all safety regulations regarding handling equipment and Road Transportation of all types of containers. The contractor shall follow the safety requirements mentioned here and as applicable by laws, rules and regulations all the time during the period of contract.
- 12.3 The contractor shall indemnify Company against any violation of safety laws, rules and regulations while carrying-out operations as required by the contract.
- 12.4 No unauthorized person should be allowed to work on the Trailers/equipment etc. The drivers and crane operators should have valid license and should be proficient in their work. No person without a valid driving license should be allowed to drive the vehicle.

**13.0 Contractor's responsibility for Insurance:**

- 13.1 Company shall arrange for insuring the project materials/properties of Company covering the risks during transit and material handling at port(s).

- 13.2 The Contractor shall during the performance of the contract take a suitable insurance to cover against bodily injury, death or damage to property of the Contractor or his employees.
- 13.3 The Contractor shall during the performance of the contract take out a Third Party insurance cover against bodily injury or death suffered by any third party/parties or damage to property occurring during the course of execution of this contract in accordance with appropriate statutory requirements.
- 13.4 If due to Contractor's carelessness, negligence, non-observance of safety precautions, improper security arrangements or due to non-compliance of paper work needed for lodging insurance claim for damage to Company/its Customer's property, if Company is unable to recover its claim from the Insurance Company, the deficit will be recovered from the Contractor.

**14.0 All Original Bill of ladings** should be issued as per UCP 600.

**15.0 Force Majeure:** The following shall amount to force majeure conditions:

- 15.1 Acts of God, Act of any Government, war, blockades, Sabotage, riots, civil Commotion , insurrection, terrorist acts, acts of Public enemy, Flood, Storms, Washouts, Fire, Explosion, landslides, lightning, Cyclone, Earthquake, epidemics, quarantine restrictions, arrest and restraints of the government, necessity for compliance with any court order, law ordinance or regulations promulgated by any governmental authority having jurisdiction, either federal /state /civil or military, strikes or other industrial disturbances, lockouts and other similar causes / events over which the Contractor has no control.
- 15.2 If the Contractor suffers delay in the due execution of the contract, due to delays caused by force majeure conditions, as defined above, the agreed time of completion of the work covered by this contract may be extended by a reasonable period of time provided notice of the happening of any such cause / event is given by the contractor to Company within 14 days from the date of occurrence thereof.
- 15.3 The Contractor by the reason of such events shall neither be entitled to terminate this contract nor shall have any claim for damages against Company in respect of such non-performance or delay in performance and deliveries under the contract shall be resumed as soon as practicable after such event has come to an end or ceased to exist, and the decision of Company as to whether the deliveries have been so resumed or not shall be final and conclusive.
- 15.4 Force Majeure conditions will apply on both sides.

**16.0 Prevention of Corruption**

- 16.1 Canvassing in any form or any attempt to influence directly or indirectly any official of Company will lead to rejection of the bid and forfeiture of the Earnest Money Deposit.
- 16.2 Company shall be entitled to cancel the contract and to recover from the Contractor the amount of any loss resulting from such cancellation, if the contractor has offered or given any person any gift or consideration of any kind as an inducement or reward for doing or intending to do any action in relation to the obtaining or the execution of the contract or any other contract with Company or for showing or intending to show favour or disfavor to any person in relation to the contract with Company, if the like acts shall have been done by any persons employed by him or acting on his behalf whether with or without the knowledge of the Contractor in relation to this or any other contract with Company.

**17.0 ARBITRATION & CONCILIATION**

**17.1 ARBITRATION:**

- 17.1.1 Except as provided elsewhere in this Contract, in case Parties are unable to reach amicable settlement (whether by Conciliation to be conducted as provided in Conciliation Clause herein below or otherwise) in respect of any dispute or difference; arising out of the formation, breach, termination, validity or execution of the Contract; or, the respective rights and liabilities of the

Parties; or, in relation to interpretation of any provision of the Contract; or, in any manner touching upon the Contract (hereinafter referred to as the 'Dispute'), then, either Party may, commence arbitration in respect of such Dispute by issuance of a notice in terms of section 21 of the Arbitration & Conciliation Act, 1996 (hereinafter referred to as the 'Notice'). The Notice shall be addressed to the Head of the ROD issuing the Contract and shall contain the particulars of all claims to be referred to arbitration in sufficient detail and shall also indicate the monetary amount of such claim. Within 60 days of receipt of the complete Notice, the Head of the BHEL ROD issuing the Contract shall offer names of three proposed Arbitrators to the invoking Party advising to choose any one of the three names to be appointed as Sole Arbitrator. On getting confirmation from the invoking Party regarding the Arbitrator chosen from among the names so offered, the Head of the BHEL ROD issuing the Contract, shall appoint such chosen person as the Sole Arbitrator for conducting the arbitration. The language of arbitration shall be English.

17.1.2 The Arbitrator shall pass a reasoned award.

17.1.3 Subject as aforesaid, the provisions of Arbitration and Conciliation Act 1996 (India) or statutory modifications or re-enactments thereof and the rules made thereunder as in force from time to time shall apply to the arbitration proceedings under this clause. The seat of arbitration shall be Mumbai. The Contract shall be governed by and be construed as per provisions of the laws of India. Subject to this provision 17.1.1 regarding ARBITRATION, the principal civil court exercising ordinary civil jurisdiction over the area where the seat of arbitration is located shall have exclusive jurisdiction over any DISPUTE to the exclusion of any other court.

17.1.4 In case of Contract with Public Sector Enterprise (PSE) or a Government Department, the following shall be applicable:

In the event of any dispute or difference relating to the interpretation and application of the provisions of commercial contract(s) between Central Public Sector Enterprises (CPSEs)/ Port Trusts inter se and also between CPSEs and Government Departments/Organizations (excluding disputes concerning Railways, Income Tax, Customs & Excise Departments), such dispute or difference shall be taken up by either party for resolution through AMRCD (Administrative Mechanism for Resolution of CPSEs Disputes) as mentioned in DPE OM No. 4(1)/2013-DPE(GM)/FTS-1835 dated 22-05-2018 as amended from time to time.

17.1.5 The cost of arbitration shall initially be borne equally by the Parties subject to the final allocation thereof as per the award/order passed by the Arbitrator.

17.1.6 Notwithstanding the existence of any dispute or differences and/or reference for the arbitration, the Contractor shall proceed with and continue without hindrance the performance of its obligations under this Contract with due diligence and expedition in a professional manner unless the dispute inter-alia relates to cancellation, termination or short-closure of the Contract by Company.

17.2 **CONCILIATION:**

If at any time (whether before, during or after the arbitral or judicial proceedings), any Disputes (which term shall mean and include any dispute, difference, question or disagreement arising in connection with construction, meaning, operation, effect, interpretation or breach of the agreement, contract), which the Parties are unable to settle mutually, arise inter-se the Parties, the same may, be referred by either party to Conciliation to be conducted through Independent Experts Committee (IEC) to be appointed by competent authority of Company from the Company Panel of Conciliators.

Notes:

1. No serving or a retired employee of Company/Administrative Ministry of Company shall be included in the Company Panel of Conciliators.

2. Any other person(s) can be appointed as Conciliator(s) who is/are mutually agreeable to both the parties from outside the Company Panel of Conciliators.

- 17.3 The proceedings of Conciliation shall broadly be governed by Part-III of the Arbitration and Conciliation Act 1996 or any statutory modification thereof and as provided in Annexure-C (will be shared by Company as and when required). The Annexure-C together with its Formats will be treated as if the same is part and parcel hereof and shall be as effectual as if set out herein.
- 17.4 The Contractor hereby agrees that Company may make any amendments or modifications to the provisions stipulated in the Annexure-C from time to time and confirms that it shall be bound by such amended or modified provisions of the Annexure-C with effect from the date as intimated by Company to it.

**18.0 Laws Governing the Contract:**

The contract shall be governed by the Indian Laws for the time being in force and only courts in Mumbai, India shall have jurisdiction over this contract.

**19.0 Indemnity:**

The Contractor shall indemnify and keep indemnified Company against all losses, claims, demurrage, detention etc. arising out of any of his acts or out of the acts of his agents or associates or servants during the execution of the contract.

**20.0 Security Deposit:**

- 20.1 Successful bidder shall submit 5% of the total contract value as security deposit **within the 05 working days (excluding bank holidays)** of issue of LOA for the contract.
- 20.2 EMD of the successful tenderer shall be converted and adjusted towards the required amount of Security.
- 20.3 Security deposit may be made in any of the following ways:
- i) Only Electronic Fund Transfer in favour of Company
  - ii) Bank Guarantee from Scheduled Banks/ Public Financial Institutions as defined in the Companies Act. The Bank Guarantee format should have the approval of Company. List of Consortium Banks for issue of Bank Guarantee enclosed with the documents.
  - iii) Fixed Deposit Receipt issued by Scheduled Banks/ Public Financial Institutions as defined in the Companies Act (FDR should be in the name of the Contractor, a/c BHEL)
  - iv) Securities available from Indian Post offices such as National Savings Certificates, Kisan Vikas Patras etc. (held in the name of Contractor furnishing the security and duly endorsed/ hypothecated/ pledged, as applicable, in favour of Company)
- (Note: Company will not be liable or responsible in any manner for the collection of interest or renewal of the documents or in any other matter connected therewith)
- 20.4 If the value of work done at any time exceeds the contract value, the amount of Security Deposit shall be correspondingly enhanced and the additional Security Deposit shall be immediately deposited by the Contractor or recovered from payment/s due to the Contractor.
- 20.5 In case of delay in submission of security deposit, enhanced security deposit which would include interest (SBI rate + 6%) for the **delayed period**, shall be submitted by the bidder. Further, if security deposit is not submitted till such time the first bill becomes due, the amount of security deposit due shall be recovered, from the bills along with due interest.
- 20.6 The security deposit shall not carry any interest. (Note: Acceptance of Security Deposit against Sl. No. (iii) and (iv) above will be subject to hypothecation or endorsement on the documents in favour of Company. However, Company will not be liable or responsible in any manner for the collection of interest or renewal of the documents or in any other matter connected therewith).
- 20.7 Securities / BG's shall be released after three **(3) months** of successful execution, completion of the contract and upon fulfillment of contractual obligations as per terms of the contract.

### **21.0 Earnest Money Deposit**

- 21.1 The offers from the bidders shall enclose a EMD as per Techno Commercial Bid in any one of the following forms: Electronic Fund Transfer credited in Company bank account (before tender opening).
- 21.2 After opening the tender and within the offer validity period, the Bidder revokes his tender or makes any modification in his tender which is not acceptable to Company.
- 21.3 The Bidder fails to deposit the required Security deposit or commence the work within the period as per LOA/ Contract.
- 21.4 If the bidder declines to accept the LOA or is unable to accept the work which has been awarded on the basis of the offer received from the bidder or revokes the offer within the validity period of the offer, the earnest money shall stand forfeited.
- 21.5 EMD by the Bidder shall be withheld in case any action on the Bidder is envisaged under the provisions of extant "Guidelines on Suspension of business dealings with suppliers/ Bidders" and forfeited/ released based on the action as determined under these guidelines.
- 21.6 EMD of successful bidder will be adjusted towards part of the security deposit.
- 21.7 EMD of all unsuccessful bidders shall be returned normally within fifteen days of placement of LOA/Work Order on successful bidder.
- 21.8 EMD shall not carry any interest.
- 21.9 In case total EMD amount is more than Rs.2.00 Lakh, the amount in excess of Rs. 2.00 lakh maybe accepted in the form of Bank Guarantee from scheduled bank. The Bank Guarantee in such cases shall be valid for at least six months. The Bank Guarantee furnished should be strictly as per Company Format.
- 21.10 Central/ State PSUs are exempted from submission of EMD.

### **22.0 Discrepancy in Words & Figures: Quoted in Offer**

- 22.1 If, in the price structure quoted for the required goods/ services/ works, there is discrepancy between the unit price and the total price (which is obtained by multiplying the unit price by the quantity), the unit price shall prevail and the total price corrected accordingly, unless in the opinion of the purchaser there is an obvious misplacement of the decimal point in the unit price, in which case the total price as quoted shall govern and the unit price corrected accordingly.
- 22.2 If there is an error in a total corresponding to the addition or subtraction of subtotals, the subtotals shall prevail and the total shall be corrected; and
- 22.3 If there is a discrepancy between words and figures, the amount in words shall prevail, unless the amount expressed in words is related to an arithmetic error, in which case the amount in figures shall prevail subject of 22.1 and 22.2 above.

### **23.0 Requirements of Performance**

- 23.1 All the permissions and Clearances or any other relevant authorization/indemnities from/to competent authority shall be obtained by the Contractor at his own cost. Any contingency arising in this respect shall be the responsibility of the Contractor. Also the Contractor shall be responsible for any mishap, accident enroute and consequences thereof including legal complications, if any.
- 23.2 The contract as entered into between Company and the contractor shall in no way, nullify, reduce, mitigate or absolve the parties of any responsibility, obligation or liability that may devolve upon them under the acts or laws governing such activity.
- 23.3 The Contractor shall take all due care for protecting the consignments from rains and be responsible for their safe and sound condition during his possession and the vehicles carrying such consignments shall be suitably equipped for the same. The Contractor shall take all due care of consignments, follow instructions given on the package, special instructions if any by supplier while loading/unloading/stowing of the cargo. During handling of cargo, he shall provide all packing and

lashing at his own cost. Contractor will be responsible for covering and uncovering of cargo with tarpaulins.

- 23.4 All the safety precautions required in transportation such as lashing and securing the consignments, providing pilots/escort (if necessary) shall be the responsibility of the Contractor at his own cost.
- 23.5 In the event of contractor backing out/not performing as per the contract, suitable action will be taken by Company as per contract. Additionally, future business of such de-faulting contractors will be suspended from business with Company as per company policy
- 23.6 Whenever asked by company, all documents including bill of lading, delivery orders, payment invoices etc. will be submitted by contractor immediately not later than three working days, failing which appropriate action as deemed fit and recovery of the losses by the company will be done.
- 23.7 In the event of the contractor going into liquidation or winding up business or making arrangements with a third party, the Company shall have the right to terminate the contract forthwith. In case any of the contractor's company becomes insolvent the contract shall automatically stand terminated.
- 23.8 In the event of vessel or its owners being declared as bankrupt or insolvent or is liable to arrest and is unable to complete the voyage then it is contractor's responsibility to make alternate arrangements at his own risk and cost to take the custody of cargo and deliver the cargo at named discharges port and complete all contractual obligation as per the scope of work.
- 23.9 In the event of midstream discharge of the cargo due to its nature/ barging operations/ draft /etc, at discharge Port, the contractor to take all permissions and make all required arrangements without any cost implications to Company. The contractor should ensure complete safety of the cargo handling operations at all times till cargo is brought to port for customs clearance and delivery.

**24.0 Short – Landed or Damaged Goods.**

- 24.1 It shall be the responsibility of Contractor to give notice of loss (damages or short landing of cargo) as per the relevant rules to the Carriers, Port authorities and Underwriters for non-delivery/short delivery/losses/damages. Under no circumstances, the intimation shall be time barred. In case of time barred cases, the loss sustained by Company shall be to the account of the Contractor.
- 24.2 In case of goods specified by Company and in case of apparent damages, the Contractor will apply for survey by Carriers, Port authorities, Underwriters etc. (including Insurance survey) within 48 hours of landing of goods. If any loss or damage is apparent, the Contractor shall lodge claim with the appropriate authorities.
- 24.3 The Contractor is responsible for safe handling and transportation of the goods.
- 24.4 The Contractor will ensure that damaged cases are repacked properly before dispatch after completing the survey by the relevant authorities.

**25.0 Subletting Not Allowed**

- 25.1 The contractor shall not sublet, transfer, or assign the contract or any part thereof. In case the contractor contravenes this condition, company shall be entitled to place the contract elsewhere at the risk and cost of the contractor and all expenses borne on this account shall be recovered from him. All details to be in line with tender provisions.
- 25.2 The contractor shall not split or transfer to any other party any part of the contract during the execution of the contract.

**26.0 Joint Survey**

- 26.1 Situations may arise during the course of handling / transportation of containers/ cargo when a container or cargo meets with an accident. The contractor may avail the services of a Surveyor on his own, at his own cost, if he so desires, to carry out a Joint Survey along with the Surveyor of Company / Consignor / Consignee / Insurance Company, /Company representative etc. for assessment of loss/damage to cargo and / or container. In case the contractor does not provide his own surveyor for the joint survey, the contractor shall not raise, subsequently, any dispute regarding the assessed value of loss/damage to cargo and/or container. Moreover, the contractor shall be under obligation

to arrange to issue "Damage Certificate" or "Short landing certificate" to the Consignor/ Consignee, within a reasonable time, enabling the Consignor/Consignee to claim compensation from the Insurance Company, in the format as desired by Company. Settlement of claims of Consignor/Consignee with Insurance Company should not lead to the conclusion on the part of the contractor that his liability is over. The contractor shall be required to settle all claims/liabilities, whatsoever, against Company, which come to Company under all such situations. The contractor may undertake to repair the damaged container, which has met with an accident under his custody, at his own initiative. This he shall do to the complete satisfaction of the concerned shipping line / Company to which the container belongs to at the time of accident.

- 27.0 Guidelines for suspension of business dealings with suppliers/ contractor's: The contractor will be binding to the "Guidelines for suspension of business dealings with suppliers/ Contractors" which is available at bhel website [www.bhel.com](http://www.bhel.com). The link for the same is available at <https://www.bhel.com/guidelines-suspension-business-dealings-supplierscontractors>**
- 28.0 Company Fraud prevention policy:** The bidder along with its associate/collaborators/sub-contractors/sub-vendors/ consultants/ service providers shall strictly adhere to Company fraud prevention policy displayed on Company web site <http://www.bhel.com> and shall immediately bring to the notice of Company Management about any fraud or suspected fraud as soon as it comes to their notice.
- 29.0 Reverse Auction:** Reverse Auction to be done on GeM portal.
- 30.0 Verification of Documents:**  
Company reserves the right to verify any documents submitted by the Bidder. Any supporting documents in line with contract copy and completion certificate like invoices, packing list, Billing details in original may be asked and Company reserves the right to reject the bid if verification from customer/ or supporting documents is not forthcoming.
- 31.0** The bidder declares that they will not enter into any illegal or undisclosed agreement or understanding, whether formal or informal with other bidder(s). This applies in particular to prices, specifications, certifications, subsidiary contracts, submission or non- submission of bids or any other actions to restrict competitiveness or to introduce cartelization in the bidding process. In case, bidder is found having indulged in above activities, suitable action shall be taken by Company as per extant policies/ guidelines.
- 32.0 Confidentiality, Use of Contract Documents and Information**
- 32.1 Bidder shall not, without Company's prior written consent, disclose the contract, or any provision thereof, or any specification, plan, drawing pattern, sample or information furnished by or on behalf of Company in connection therewith, to any person other than a person employed by Bidder in the performance of the contract. Disclosure to any such employed person shall be made in confidence and shall extend only so far, as may be necessary for purposes of such performance.
- 32.2 Bidder shall not, without Company's prior written consent, make use of any document or information provided by the Company except for purposes of performing the contract.
- 32.3 Any document supplied to the Bidder in relation to the contract other than the Contract itself remain the property of Company and shall be returned (in all copies) to Company on completion of Bidder's performance under the Contract if so required by Company. All information obtained by Bidder in the conduct of operations and the information/drawings/documents provided to the Bidder shall be considered confidential and shall not be divulged by Bidder or its employees to anyone other than the Company's personnel. This obligation of Bidder shall be in force even after the termination of the contract.
- 33.0 Integrity commitment, performance of the contract and punitive action thereof:**
- 33.1 **Commitment by Company:**

- 33.1.1 Company commits to take all measures necessary to prevent corruption in connection with the tender process and execution of the contract. Company will, during the tender process treat all Bidder(s) in a transparent and fair manner, and with equity.
- 33.2 Commitment by Bidder/ Supplier/ contractor:**
- 33.2.1 The bidder/ supplier/ contractor commit to take all measures to prevent corruption and will not directly or indirectly influence any decision or benefit which he is not legally entitled to nor will act or omit in any manner which tantamount to an offence punishable under any provision of the Indian Penal Code, 1860 or any other law in force in India.
- 33.2.2 The bidder/ supplier/ contractor will, when presenting his bid, disclose any and all payments he has made, and is committed to or intends to make to agents, brokers or any other intermediaries in connection with the award of the contract and shall adhere to relevant guidelines issued from time to time by Govt. of India/ Company.
- 33.2.3 The bidder/ supplier/ contractor will perform/ execute the contract as per the contract terms & conditions and will not default without any reasonable cause, which causes loss of business/ money/ reputation, to Company.
- 33.2.4 If any bidder/ supplier/ contractor during pre-tendering/ tendering/ post tendering/ award/ execution/ post-execution stage indulges in mal-practices, cheating, bribery, fraud or and other misconduct or formation of cartel so as to influence the bidding process or influence the price or acts or omits in any manner which tantamount to an offence punishable under any provision of the Indian Penal Code, 1860 or any other law in force in India, then, action may be taken against such bidder/ supplier/ Bidder as per extant guidelines of the company available on [www. bhel.com](http://www.bhel.com) and/or under applicable legal provisions”.
- 34.0 Stacking and Tiltability Of Cargo/Packages:**  
The cargo should be stacked as per usual shipping standard practices. However, if any specific stacking information required the same can be given by supplier.
- 35.0 E- Procurement:**
- 35.1 This tender will be conducted, evaluated and finalized online through GeM portal. The bidder shall submit his response through bid submission to the tender on GeM website as given in the General Information table.
- 35.2 Neither the Organization (Bharat Heavy Electricals Ltd.) nor the GeM portal (as given General Information table) is responsible for any failure of submission of bids due to failure of internet or other connectivity problems /uploading of corrupted unreadable bids or any reasons thereof. If e-offers found unreadable/corrupted files while decrypting the same will be ignored for further evaluation purpose.
- 36.0 Congestion at Ports:** In case of any congestions at load / discharge port, the Contractor to do all necessary work for priority vessel/barge berthing. Company shall not be responsible for any vessel/barge idling /Vessel detention charges due to delay in berthing including (1) Delay in allocation of berth at load / discharge port (2) Delay in berthing of the vessel/barge due to non-availability of the customs clearance documents (3) Delay in berthing for want of arrangement of requisite Trucks/ Trailers / Barges/ Crane etc. for direct delivery from the vessel/barge. No congestion charges will be paid.
- 37.0 Packing List:** The approximate weight and dimension is enclosed in packing list as they are based on engineering design. Please note that the weights and sizes given are indicative and for guiding the contractor. The actual Dispatch particulars may vary and shall be known at an appropriate stage. Contractor shall not claim any compensation from Company towards such variation in actual dispatch particulars of cargo/packages/shipments.

**38.0 Conflict of interest among Bidders/ Agents:** A bidder shall not have conflict of interest with other bidders. Such conflict of interest can lead to anti-competitive practices to the detriment of Procuring Entity's interests. The bidder found to have a conflict of interest shall be disqualified. A bidder may be considered to have a conflict of interest with one or more parties in this bidding process, if:

- a) They have controlling partner (s) in common; or
- b) They receive or have received any direct or indirect subsidy/ financial stake from any of them; or
- c) They have the same legal representative/agent for purposes of this bid; or
- d) they have relationship with each other, directly or through common third parties, that puts them in a position to have access to information about or influence on the bid of another Bidder; or
- e) Bidder participates in more than one bid in this bidding process. Participation by a Bidder in more than one Bid will result in the disqualification of all bids in which the parties are involved. However, this does not limit the inclusion of the components/ sub-assembly/ Assemblies from one bidding manufacturer in more than one bid; or
- f) In cases of agents quoting in offshore procurements, on behalf of their principal manufacturers, one agent cannot represent two manufacturers or quote on their behalf in a particular tender enquiry. One manufacturer can also authorize only one agent/dealer. There can be only one bid from the following:
  - 1. The principal manufacturer directly or through one Indian agent on his behalf; and
  - 2. Indian/foreign agent on behalf of only one principal; or
- g) A Bidder or any of its affiliates participated as a consultant in the preparation of the design or technical specifications of the contract that is the subject of the Bid; or
- h) In case of a holding company having more than one independently manufacturing units, or more than one unit having common business ownership/management, only one unit should quote. Similar restrictions would apply to closely related sister companies. Bidders must proactively declare such sister/ common business/ management units in same/ similar line of business.

**39.0 Status/Progress Reporting of the contract.**

- 39.1 The progress report shall indicate the progress achieved against planned with reasons indicating delays, if any, and shall give the remedial actions which the Contractor intends to take to make good the slippage or lost time, so that further works again proceed as per the original program and the slippages do not accumulate and effect the overall program.
- 39.2 The daily reports shall clearly indicate the cargo status, vessel status, customs clearance status work force deployed, category-wise, specifying also the activities in which they are engaged etc.
- 39.3 Weekly progress review meetings will be held at any suitable location during which actual progress during the week vis-à-vis scheduled program shall be discussed or actions to be taken for achieving targets. For discussions, the Contractor shall present program of subsequent week. The Contractor shall constantly update/revise his work program to meet the overall requirement.
- 39.4 During execution or before loading the packages, Contractor shall take colour digital photograph on mobile and forward the same on whatsapp/email etc. for each milestone as applicable for all important activities of the works during progress and after reaching of consignment at major locations.
- 39.5 Successful contractor has to provide for electronic/ computerized storing and re-production/ printing/ plotting of various data, photo, protocols, measurements etc. These may be stored in Removable hard disk (as per requirement) and handed over to Company on monthly basis, if required.
- 39.6 The contractor shall be bound to report movement progresses of all shipments through electronic communication systems such as Fax, Mobile telephony/STD hones/Roaming cell phones, email, web based monitoring system or any other mode desired by Company at regular intervals.

- 40.0** In case of BB shipment, no vessel should be booked unless Final Packing list is received by Freight Forwarder from supplier. If any compensation/additional charges is asked by Shipping line/vessel owner due to change in dimension/weight in packing list, it will not be payable by company.
- 41.0** Contractor to consult with supplier and if LC payment is not applicable, then Express BL should be issued to supplier.

Seal of the Company & Date

Signature & Name of Contractor

## SECTION IV

## FORMAT FOR PQR AND TECHNO- COMMERCIAL BID

Sr No	Description	Confirmation by Bidder
<b>Pre-Qualification Requirement (PQR)</b>		
1	Bidder must have an average annual turnover (revenue from operations) of the company of not less than Rs 4.06 Lakhs for the last three Years (i.e. for year, 2019-2020, 2020-21 & 2021-22). If Turnover for 2022-23 is available, average of last three years from 2022-23 to be considered.	Copy of audited financial statements with P & L to be submitted with UDIN no. or CA certificates in prescribed format with UDIN number to be submitted.
2	Bidders must submit proof of having successfully executed ocean freight contracts (any logistics contract inclusive of Ocean Freight) in last <b>seven</b> years (ending last day of month previous to the one in which the tender was due for opening) as per following (1) <b>Three</b> contracts of value not less than Rs 5.41 Lakh each OR (2) <b>Two</b> contracts of value not less than Rs 6.76 Lakh each OR (3) <b>One</b> contract of value not less than Rs 10.82 Lakh NOTES: Details of the customer with email, contact details and office address are also required for verification. In case completion certificate are not verifiable due to any reason then such bids may be rejected.	<b>Copies of contract / work order with satisfactory completion certificate of the work executed or completed from customer must be attached.</b>
4	EMD Details. Email to be sent on submission of EMD with UTR details MSE Parties to submit valid UDHYAM certificate	<b>UTR NO. to be provided</b>
5	The offers of the bidders who are under suspension as also the offers of the bidders, who engage the services of the banned firms, shall be rejected. The list of banned firms is available on Company web site www.bhel.com. Bidder to submit below self – certification: "The (company name) has not been Suspended for business dealing by BHEL and we do not engage services of any banned firms available on www.bhel.com."	A self-certification should be submitted by the bidder indicating compliances. <b>Date to be mentioned on the certificate</b>
6	The Bidder should not have been referred to BIFR/NCTL or declared 'SICK' by any Statutory Authority. Bidder to submit below self- certification: "The (company Name) has not been referred to BIFR and Interim Resolution Professional (IRP) has not been appointed for initiating insolvency proceedings by NCLT as on date of publication of NIT".	A self-certification should be submitted by the bidder indicating compliances <b>Date to be mentioned on the certificate</b>
7	The Bidder is required to state whether any owner or director is also Director of BHEL or related to any Director of BHEL. Note - Latest list is available in the company web site. Bidder may check for any changes in the list of directors at the time of submission.  1] Provide Name of the director or owner of contractor who is also Director of BHEL 2]Provide Name of the Director of the BHEL who is related to the any of director / owner of contractor	Details, whichever applicable to be submitted: In case none is applicable then bidder should submit self – declaration stating same.
8	Name, Address, email and contact details of the company office running in Mumbai Metropolitan Region (MMR).	Electricity Bill/ Telephone Bill/ Rent agreement or any other document verifying the same.
<b>Techno Commercial Bid</b>		
9	<b>Tender Documents:</b> Entire tender document along with GeM bid document with sign and seal of authorized signatory on all pages	To be submitted
10	<b>Compliance Letter:</b> The compliance letter duly signed and stamped on letter head is to be uploaded.	On letter head to be Uploaded

11	<b>PAN CARD</b> of the company, <b>GST</b> Certificate of the company, Application form with Bank signed E-mandate	Copies to be submitted
12	<b>Authority Letter</b> : An authority letter indicating that the person signing the IPA is the duly authorized by the company/firm	To be submitted
13	<b>Transit Penalty:</b> As Specified in tender Terms & Condition	Agreed
14	<b>Force Majeure:</b> As specified in the tender Terms & Conditions	Agreed
15	<b>Validity of The Contract.</b> The contract will remain valid till all the activities as per scope of work is completed or till 4 months from the date of LOA whichever is later.	Agreed
16	<b>Submission of Security Deposit:</b> Bidder agrees to submit performance security required for execution of the contract within the time period mentioned. In case of delay in submission of performance security, enhanced performance security, which would include interest (SB/ rate + 6%) for the delayed period, shall be submitted by the bidder. Further, if performance security is not submitted till such time the first bill becomes due, the amount of performance security due shall be recovered as per terms defined in NIT I contract, from the bills along with due interest.	Agreed
17	<b>Lifting Beams &amp; Accessories:</b> Contractor to arrange for lifting beams/spreader beams/parallel bars, hydraulic stools and other accessories as required for loading, unloading of the cargo both in India and overseas, if required.	Agreed
18	<b>GST</b> shall be paid only on reflection in GSTR2A of BHEL GSTIN: 27AAACB4146P1ZF. Contractor to comply with GST law and its requirement. if any penalty or interest is incurred by Company due to non-compliance by contractor, the penalty/interest incurred would be recovered from the contractor.	Agreed
19	<b>Cancellation Of The Contract:</b> As Specified in tender Terms & Conditions	Agreed
20	<b>Govt. Rules &amp; Regulations:</b> Contractor to abide by all the rules and regulations related to Road/ ocean transportation, traffic, police, customs, port etc. These would include all levies, licenses, and permits for operation in India / transit country / load port country. It is obligatory for Contractor to comply with regulating requirements in load port country are fully met before award of the contract.	Agreed
21	<b>Risk Purchase:</b> In the event of failure of Contractor to Ship the consignment offered to them within 31 days of readiness of cargo, BHEL reserves the right to use alternative source at their risk and cost and extra expenditure incurred if any shall be borne by the Contractor. Contractor shall ensure that the vessel is placed as per contract.	Agreed
22	<b>Reverse Auction:</b> The contractor accepts to participate in the Reverse Auction on GeM portal.	Agreed
23	<b>Offer Validity:</b> The offer of bidders will be valid for 45 days from due date of tender and extension thereof.	Agreed
24	If at any point of time it is found that the details furnished by the contractor are not correct then BHEL reserves the right to cancel the contract, forfeit security deposit and initiate risk purchase	Agreed
25	<b>Dead Freight:</b> Contractor has to coordinate and plan the movement of cargo with all concerned agencies. Under any circumstance Vessel detention / Dead Freight will not be paid at all.	Agreed
26	All payments will be made as per actual cargo being handled/ executed.	Agreed
27	<b>The order will be placed only on one party due to operational exigency / efficiency.</b>	Agreed
28	<b>Container detention free period of 15 days.</b>	Agreed

29	<b>Filing with BHEL DPD CODE will be done with</b> necessary permissions from the relevant agencies at Port / CFS etc without any involvement of Company, <b>without any additional cost to BHEL.</b>	Agreed
----	---	--------

**\*Note: If Bidder has submitted BHEL contract and SD has been released without any deduction, then that Work Order value will be treated as successfully executed contract.**

Seal of the Company & Date

Signature & Name of Contractor

**SECTION VI**  
**FORMAT FOR PRICE BID**

Sn	Description	% allocation	Total Qty. (tentative)	UOM	Basic Value in INR	GST INR	Total Value in INR
(a)	(b)	(c)	(d)	(e)	(f)	(g)	(h) = (f) + (g)
1	Ex Works charges for Transporting the material from Factory at M/s. Hitachi Energy Sweden AB, 77180 Ludvika, Sweden of the supplier to the Load port – includes all ex-works charges to be incurred at origin as per scope of work	23 % of 4(h)	3 Pkgs	Lumpsum			
2	Rate for ocean freighting from Gothenberg Sea Port, Sweden to Nhava Sheva in 2 x 40' GP/HC containers as per scope of work.	50% of 4(h)	3 Pkgs	Lumpsum			
3	Terminal Handling Charges at Nhava Sheva ( Includes washing charges, Maintenance charges, Delivery Order etc ) Should include all destination charges as per scope of work	27 % of 4(h)	3 Pkgs	Lumpsum			
4	Total Cost to BHEL in INR (1(h)+2(h)+3(h))	100% of 4(h)	<b>(This value should be entered in GEM portal as total price)</b>				

**Note:**

1. Bidder to quote Total Cost to BHEL inclusive of all line items as per above Table
2. Evaluation / RA will be done on Total Cost to BHEL in INR in 4(h) shown in above table (highlighted in green)
3. Prices are to be quoted by vendor as inclusive of all taxes and levies in India and Outside India.
4. No other shipping line charges will be payable separately.
5. No charges other than those specified in the contract shall be payable.
6. **Container Detention free period required: 15 days**
7. No additional payment (GRI/RRI etc) on any account shall be considered for payment.
8. No additional choking/lashing charges shall be applicable.
9. If any new tax in India is introduced by Central/ State Govt, etc, and becomes directly applicable on items specified in the price bid, full reimbursements shall be made provided it becomes applicable on items specified in the price bid.
10. Bidder must fill all the schedules and Price for each and every items. If the bidder fails to quote any of the items in Price Bid, he will be disqualified and will not be allowed to participate in Reverse Auction.
11. Contractors to note that this is an item rate contract. Payment shall be made for the actual quantities of work executed at the unit rate
12. **Bidder to submit the final price breakup on pro-rata basis as per Price Bid (Section VI) within the same day of completion of RA.**
13. **Custom duty, if applicable, at load port will be payable at actuals through reimbursement by company to the contractor. For the purpose of conversion from SEK/ EUR to INR, the SBI TT selling rate prevailing on the date of duty payment as mentioned in the shipping bill/ duty payment challan will be considered. In case there is a bank holiday on the date of Bill of Lading, then the rate prevailing on the previous working day will apply.**

Seal of the Company &amp; Date

Signature &amp; Name of Contractor

**SECTION –VII**

(Letter of compliance in Company's Letter Head)

Ref No:

Date:

To,

M/s Bharat Heavy Electricals Limited,  
14/15<sup>th</sup> Floor, World Trade Centre-1,  
Cuffe Parade, Mumbai –5

**Sub: Compliance letter for Your Tender no RE/MUM/IMP/HW/IS-2307**

Dear Sir,

With reference to your above tender, we have carefully read and understood the tender terms & conditions and hereby confirm that all the terms and conditions of your above tender are acceptable to us and our offer is based on the same.

In view of the above confirmation, any deviation mentioned by us anywhere in the tender is not valid and is to be ignored by BHEL while finalising the Tender.

Further, it is also confirmed that we have submitted the price bid in your price bid format only without any deviations / conditions.

In case, any deviation is observed in the financial bid the same is not be entertained / considered by BHEL.

I agree to furnish any other information / produce any record for inspection as may be required by the competent authority or an officer duly authorized by the competent authority of Bharat Heavy electrical Limited.

I / We also give the undertaking that all the statutory acts, rules & regulations applicable to International Business and to central /state Govt. in load port and discharge port country are being and will be followed by us in course of our operations/ execution of the contract.

We are aware and now conversant with local site conditions / Weather conditions / Route feasibility to site/Local social issues/Local labor issues/Local political issues/ Geo-political situation/ Work Culture/ Weekly holidays/ festivals Holidays, etc.

The above information is true and correct and we will not raise any claim of any nature due to lack of knowledge of site conditions both in load port country / discharge country and enroute.

I affirm that the particulars given are true to best of my knowledge and belief.

Thanking you,

Yours faithfully,

SIGNATURE AND SEAL OF BIDDER

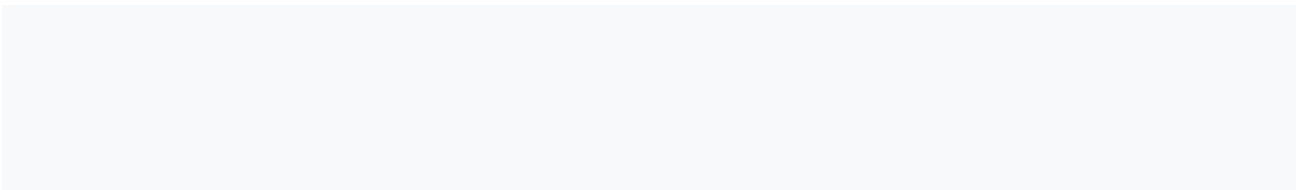

Snapshot of cargo

### Transport box of GGF600

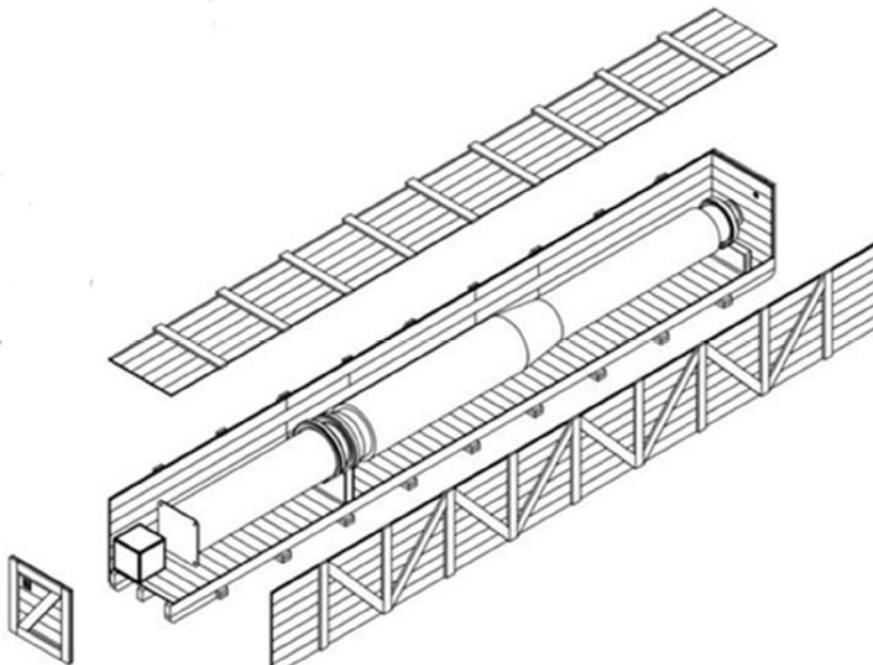
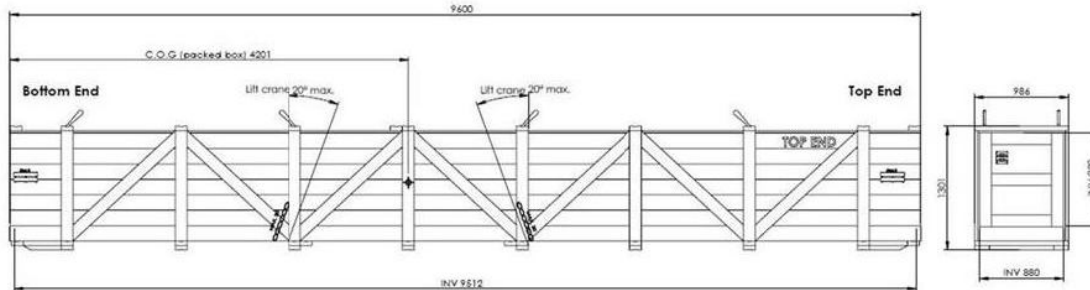

On the inside, the bushing shall be supported at the fastening flange and at the flange at top of the bushing.

Weight of bushing with transport container: 2200 kg

Bushing shall be empty of SF6 gas during transport and filled with dry air instead.