

## Amit Meena

---

**From:** gauravdixit <gauravdixit@bhel.in>  
**Sent:** 18 October 2021 16:20  
**To:** 'AMIT MEENA'  
**Cc:** 'SANJAY KUMAR-PEM'; 'Sweta'; INDRA.PAL.SINGH@BHEL.IN; Anil Kumar Pal(Sr Manager/PGII/PS-PEM)  
**Subject:** RE: 2 X 660 MW THDC KHURJA-TG : INDENT FOR M.E. BELLOWS  
**Attachments:** 2X660MW KHURJA STPP (TG PKG) project - Password for password protected e... (9.41 KB)

Sir,

Password protected estimate was already shared on e-office (under local reference) along with indent. As Open Estimates are requested due to GeM requirement, find attached password (refer attached email) for opening the password protected pdf.

सादर / With regards,  
गौरव दीक्षित / Gaurav Dixit  
उप-प्रबंधक (एमपीएल) / DY. MGR (MPL)  
भारत हेवी इलेक्ट्रिकल्स लिमिटेड / Bharat Heavy Electricals Limited  
पीएस-पीईएम, पीपीईआई भवन / PS-PEM, PPEI Building  
दूरभाष/Telephone + 91 120 4283503

---

**From:** Amit Meena <amitmeena@bhel.in>  
**Sent:** Monday, October 18, 2021 3:31 PM  
**To:** gauravdixit@bhel.in  
**Cc:** sweta@bhel.in; 'SANJAY KUMAR' <sanjaykum@bhel.in>; indra.pal.singh@bhel.in; anilkumarpal@bhel.in  
**Subject:** 2 X 660 MW THDC KHURJA-TG : INDENT FOR M.E. BELLOWS

Dear Sir,

Please share the estimate sheet generated through PULSE or password to enable us to open the estimate sheet from e office for subject indent in order to float the tender through GeM Portal for Khurja –ME Bellows.

Regards

Amit Meena |Manager| PG II |Intercom No-4613

## Amit Meena

---

**From:** Nitin Kumar <nitin.kumar@bhel.in>  
**Sent:** 06 October 2021 12:28  
**To:** 'Amit Meena'  
**Subject:** FW: Khurja TG- HT Cable-Diversion

Nitin Kumar  
PG-II, BHEL-PEM, Noida  
Mobile: 9871497600  
Phone: 0120-4368756  
Extn: 8756

---

**From:** Mukul Sharma [mailto:mukulsharma@thdc.co.in]  
**Sent:** 15 July 2021 09:34  
**To:** nitin kumar <nitin.kumar@bhel.in>  
**Cc:** Kumar Sharad AGM, Rishikesh, THDC, PAID <kumarsharad@thdc.co.in>  
**Subject:** Re: Khurja TG- HT Cable-Diversion

\_/\*\*/

Dear Sir,

We are getting repeated requests for diversion of old material from different projects. In such cases it is difficult to ensure the quality of the product.

It is therefore requested to kindly procure only new items as per laid down specifications for Khurja STPP. No such request except in emergency / extraordinary situation will be reviewed in future for approval.

Regards,

**मुकुल शर्मा**  
**उप महाप्रबंधक (TG)**  
**Khurja STPP,**  
**टी. एच्. डी.सी इंडिया लिमिटेड,**  
**9899144865**

---

**From:** "nitin kumar" <[nitin.kumar@bhel.in](mailto:nitin.kumar@bhel.in)>  
**To:** "Mukul Sharma" <[mukulsharma@thdc.co.in](mailto:mukulsharma@thdc.co.in)>  
**Cc:** [anilkumarpal@bhel.in](mailto:anilkumarpal@bhel.in), [akshattomar@bhel.in](mailto:akshattomar@bhel.in)  
**Sent:** Wednesday, July 14, 2021 2:30:40 PM  
**Subject:** Khurja TG- HT Cable-Diversion

Sir,

Approximately 3 kms of surplus 11kV 1Cx630 sq mm HT XLPE Power Cable of our Yeramarus site can be utilised for Khurja TG project and is available for diversion to Khurja TG site.

Data sheet and short circuit capability of Armour is attached. Please note that as the drum size is 600m, diverted cable would be used for UAT feeder where per feeder length is around 100m and there will be no requirement of jointing kits.

Please furnish your acceptance for diversion.

Nitin Kumar

PG-II, BHEL-PEM, Noida

Mobile: 9871497600

Phone: 0120-4368645

Extn: 8645

### इलेक्ट्रॉनिक ट्रांसमिशन संदेश- ई-मेल के लिए डिस्क्लेमर

इस इलेक्ट्रॉनिक ट्रांसमिशन संदेश में दी गई जानकारी अर्थात ई-मेल और इस इलेक्ट्रॉनिक संदेश के साथ प्रेषित कोई अटैचमेंट केवल प्रेषिती (प्रेषितियों) के उपयोग के लिए है और इसमें व्यक्ति विशेष के लिए, गोपनीय या विशेष रूप से अधिकृत जानकारी हो सकती है। यदि यह जानकारी आपके लिए नहीं है तो आपको इस ई-मेल को प्रसारित, वितरित या कॉपी न करें। यदि आपको यह संदेश गलती से मिला है, तो आपको इस संदेश को नष्ट करना चाहिए और ई-मेल द्वारा प्रेषक को सूचित कर दें।

ई-मेल ट्रांसमिशन सुरक्षित या त्रुटिरहित होने की गारंटी नहीं है, क्योंकि जानकारी ट्रांसमिशन के दौरान अवरुद्ध हो सकती है, विकृत हो सकती है, खो सकती है, नष्ट हो सकती है, देर से या अपूर्ण रूप में पहुंच सकती है, या वायरस से ग्रस्त हो सकती है। इसलिए, ई-मेल और इसकी विषय-वस्तु (निर्दिष्ट त्रुटियों के साथ या उनके बगैर) की जिम्मेवारी ई-मेल तैयार करने वाले / प्रेषक या बीएचईएल या उसके सहयोगियों

की नहीं होगी। इस ई-मेल में उल्लिखित विचार या राय, यदि कोई हो, प्रेषक के ही हैं। यह आवश्यक नहीं है कि ये बीएचईएल या इसकी सहयोगी कंपनियों के विचार या राय के साथ मेल खाएं। लक्षित प्राप्तकर्ता ई-मेल या इसकी विषय-वस्तु पर कार्रवाई करने से पहले वैकल्पिक संचार तंत्र के माध्यम से जानकारी या निहितार्थ को सत्यापित करवा सकते हैं।

चेतावनी: यद्यपि कंपनी ने यह सुनिश्चित करने के लिए कि इस ई-मेल में कोई वायरस मौजूद नहीं हो, काफी सावधानी बरती है, फिर भी प्राप्तकर्ता यह जाँच कर लें कि इस ई-मेल और इसके अटैचमेंट्स में वायरस न हों। इस ई-मेल द्वारा संक्रामित किसी वायरस के कारण होने वाली किसी क्षति के लिए ई-मेल का प्रेषक या बीएचईएल जिम्मेदार नहीं हैं।

### Disclaimer for the Electronic Transmission Message- E-mail

The information contained in this Electronic Transmission Message i.e. E-Mail and any attachments to this electronic message are intended for the exclusive use of the address(s) and may contain proprietary, confidential or privileged information. If you are not intended recipient, you should not disseminate, distribute or copy this e-mail. If you have received this message in error, you should destroy this message and may please notify the sender by email.

E-mail transmission is not guaranteed to be secure or error-free as information could be

501929/2021/PS-PEM-MPL



## PRE - QUALIFYING REQUIREMENTS

DOCUMENT NO: PE-TS-475-000-M052

REVISION NO: 00, DATE: 11.10.2021

SHEET: 1 of 2

Standard document No.:PE-TS-999-000-M052

**Project: 2X660MW KHURJA STPP (TG PKG)****Package: METAL EXPANSION BELLOWS****CRITERIA FOR EVALUATION (TECHNICAL):**1. Technical Pre-Qualifying Requirements:

1.1 The bidder should have designed, in-house manufactured, tested, inspected and supplied metal expansion bellows (Gimbal / Hinged) with minimum size of 1600 NB (Min. Design pressure: 1.1 Kg/cm<sup>2</sup>(g), Min Design temperature: 50°C), for use in power cycle piping of power plant or for similar application in other industries.

1.2 The item(s) mentioned in point 1.1 should have performed successfully for atleast one year. To establish meeting this requirement, the bidder shall conform to any one of the following clauses:

- (i) Execution of two purchase orders for different End-users with the item(s) performing successfully for one (1) year from date of commissioning to the date of bid submission as defined in Notice Inviting Tender (NIT) by BHEL-PEM. Different projects of a customer shall be considered as different End-users.
- (ii) Minimum one (1) repeat contract from two (2) different Purchasers (i.e. 2 Nos of Purchase orders from each purchaser). A contract shall be considered as repeat, when the second contract is given by the same purchaser after lapse of minimum one (1) year from supply completion of first contract.
- (iii) Execution of one (1) purchase order as per sl. no. (i) above from one End-user and one (1) repeat contract from another Purchaser as per sl. No. (ii) above.
- (iv) Three (3) repeat contracts from one (1) Purchaser. Second and third repeat contract shall be after lapse of minimum one (1) & two (2) years respectively from supply completion of first contract.

1.3 The bidder to furnish the following documents, as applicable, in support of the above:

- a) For point 1.2(i): Performance certificates from End-user (duly signed & dated) specifying that the product is performing successfully for one (1) year from date of commissioning along with correlated purchase order(s).
- b) For point 1.2 (ii) & (iv): Purchase order(s), Material dispatch clearance certificate (MDCC)/ Material receipt certificate (MRC)/Lorry receipt (LR)/supply invoice.

1.4 In addition to above, bidder should have the following facilities for Metal expansion bellows of max. size of each type as per BHEL requirement as mentioned in Data sheet of technical specification:

- a) In-house capability of manufacturing metal expansion bellows.
- b) In-house testing facilities for carrying out tests as per relevant standards & Quality plan. In case, the in-house testing facilities are not available, then bidder shall furnish undertaking that test(s) will be carried out from govt. approved lab or test house recognized by reputed customers.

**PREPARED BY:**

*Gaurav Dixit*  
 PE - PS (MPL)  
 DATED 11.10.21

**NAME:** GAURAV DIXIT  
**DESIGNATION:** DY MGR  
**DEPT.:**PS-PEM/ MPL

**REVIEWED BY:**

**SANJAY**  
**KUMAR**  
Digitally signed by SANJAY KUMAR  
 DN: cn=SANJAY KUMAR, o=BHEL, ou=PEM, c=IN  
 Date: 2021.10.13 09:38:04 +05'30'

**NAME:** SANJAY KUMAR  
**DESIGNATION:** SDGM  
**DEPT.:** PS-PEM/ MPL

**APPROVED BY:**

**Bimal Kumar**  
**Agarwal**  
Digitally signed by Bimal Kumar Agarwal  
 Date: 2021.10.13 09:49:23 +05'30'

**NAME:** B K AGARWAL  
**DESIGNATION:** DH/MPL

501929/2021/PS-PEM-MPL



## PRE - QUALIFYING REQUIREMENTS

DOCUMENT NO: PE-TS-475-000-M052

REVISION NO: 00, DATE: 11.10.2021

SHEET: 2 of 2

Bidder to submit supporting documents (Purchase order (s) / Certificate indicating capacity and details/undertaking of manufacturing & testing facilities) for point (a) & (b) above.

- 1.5 To establish business continuity, bidder is required to submit at least (2) Purchase order for any type of Metal expansion bellows (from Data Sheet Part-1 of technical specification) for minimum 300NB size in last 3 (three) years from date of bid submission as defined by BHEL-PEM in NIT.
2. Bidder to also comply with general points mentioned below:
- 2.1 Offers of the JV companies/ Joint bidders/ bidders having collaboration/ licensing agreement/ MOU/ Indian subsidiaries shall be evaluated as follows:
- If bidder happens to be an Indian subsidiaries of foreign OEM, then the credentials of the foreign OEM can also be considered for meeting PQR.
  - If bidder happens to be the Joint Venture Company, then the credentials of any of JV partners can be also considered for meeting PQR.
  - If bidder happens to be the having valid collaboration agreement/ MOU/ licensing agreement with some other company, then the credentials of collaborator/ MOU partner/ licensing company can also be considered for meeting PQR.

Note: If bidder(s) qualifies on the basis of credentials of his principal/ JV partner/ Collaborator/ joint bidder etc., then the principal/ JV partner/ Collaborator/ MOU partner/ joint bidder shall be responsible for overall design vetting and warranty/ guarantee of the package. The scope matrix clearly defining their respective roles including design vetting, manufacturing of critical component, E&C etc. and warranty/ guarantee shall be submitted along with the offer.

- Bidder to note that the arrangement of bidding (joint bid partners/ collaborator/ MOU partner/ licensing company etc.) once offered to BHEL as a part of bidding documents cannot be changed till the execution of contract(s).
- Consideration of offer shall be subject to customer's approval of bidders, if applicable.
- Bidder to submit all supporting documents in English. If documents submitted by bidder are in language other than English, a self-attested English translated document should also be submitted.
- Notwithstanding anything stated above, BHEL reserves the right to assess the capabilities and capacity of the bidder/collaborators to perform the contract, should the circumstances warrant such assessment in the overall interest of BHEL.
- After satisfactory fulfillment of all the above criteria/requirement, offer shall be considered for further evaluation as per NIT and all the other items of the tender.
- Bidder to ensure that Third Party/customer issued certificates being submitted as proof of PQR qualification should have verifiable details of document/ certificate issuing authority such as name & designation of issuing authority and its organization contact number and email-id etc. In case the same found not available, purchaser has right to reject such document from evaluation.

PREPARED BY:

*Gaurav Dixit -  
DY - MGR (MPL)*  
DATED 11.10.21

**NAME:** GAURAV DIXIT  
**DESIGNATION:** DY MGR  
**DEPT.:** PS-PEM/ MPL

REVIEWED BY:

**SANJAY  
KUMAR**  
Digitally signed by SANJAY  
KUMAR  
DN: cn=SANJAY KUMAR,  
o=BHEL, ou=PEM,  
email=sanjaykumar@bhel.co.in  
Date: 2021.10.13 09:58:29 +05'30'

**NAME:** SANJAY KUMAR  
**DESIGNATION:** SDGM  
**DEPT.:** PS-PEM/ MPL

APPROVED BY:

**Bimal Kumar  
Agarwal**  
Digitally signed by Bimal Kumar  
Agarwal  
Date: 2021.10.13 09:52:52 +05'30'

**NAME:** B K AGARWAL  
**DESIGNATION:** DH/MPL

# **2X660MW KHURJA STPP (TG PKG)**

## **TECHNICAL SPECIFICATION**

### **FOR**

## **METAL EXPANSION BELLOWS**

**SPECIFICATION NO: PE-TS-475-100-M021 REV-00**



**BHARAT HEAVY ELECTRICALS LIMITED, POWER SECTOR  
PROJECT ENGINEERING MANAGEMENT  
NOIDA, INDIA**

501929/2021/PS-PEM-MPL

	<b>TECHNICAL SPECIFICATION METAL EXPANSION BELLOWS</b>	SPECIFICATION NO. PE-TS-475-100-M021 REV-00
	<b>2X660MW KHURJA STPP (TG PKG)</b>	DATE: 07/10/2021

## CONTENTS

SL NO.	SECTION	TITLE	NO. OF SHEETS
1.	SECTION-I	SPECIFIC TECHNICAL REQUIREMENTS	7
2.	SECTION-II	DATA SHEET <ul style="list-style-type: none"> <li>• PART-1: BOQ FOR METAL EXPANSION BELLOWS</li> <li>• PART-2: GENERAL CONSTRUCTIONAL DETAIL</li> <li>• PART-3: MATERIAL OF CONSTRUCTION DETAIL</li> </ul>	1 1 1
		QUALITY PLAN	6
		COMPLIANCE SHEET	1
3.	SECTION-III	ANNEXURE-1: REFERENCE GA DRAWINGS OF ME BELLOWS	6

	<b>TECHNICAL SPECIFICATION METAL EXPANSION BELLOWS</b>  <b>2X660MW KHURJA STPP (TG PKG)</b>	SPECIFICATION NO. PE-TS-475-100-M021 REV-00	
		DATE: 07/10/2021	SECTION-I
		SPECIFIC TECHNICAL REQUIREMENTS	SHEET 1 OF 7

## SECTION-I: SPECIFIC TECHNICAL REQUIREMENTS

### 1. GENERAL

- 1.1. The Metal Expansion Bellows shall meet the technical requirements and conform to the requirements of Section-I and Data Sheet of section II. However, in the event of contradictions between Section-I & Data sheet of Section-II, Data Sheet will prevail.
- 1.2. Vendor to manufacture bellows as per final BHEL approved GA drawings which will be prepared in accordance with reference drawings & DATA Sheet. Any ambiguity in constructional/dimensional detail must be communicated to BHEL. Such changes, if any, will be subjected to BHEL approval and will NOT have any cost implication on BHEL.

### 2. SCOPE OF SUPPLY

- 2.1 The bellows to be supplied shall be as per Data Sheet. For detail, refer the same.
- 2.2 Special Tools and tackles, if any.

### 3. CODES & STANDARDS

- 3.1 The design, manufacturing, performance and testing of the expansion bellows shall conform to the latest editions of the relevant codes and standards inclusive of the stipulations in the latest edition of Expansion Joint Manufacturers Association Standards (EJMA), ASME Section IX, ASME B 16.25, ASME Section VIII, ASTM E-165, ASME SEC-V and ASME- B31.1.
- 3.2 In case the specification differs with the requirement of Codes/Standards, the specification shall govern.

### 4. DESIGN REQUIREMENTS

- 4.1 The design calculations of bellows shall be as per latest edition of EJMA.
- 4.2 Dimensional tolerance for the expansion bellows should be as per latest edition of EJMA.
- 4.3 The expansion bellows shall be capable of withstanding design pressure and 50mm of Hg (abs).
- 4.4 FEA analysis shall be carried out for Tied, Hinged and Gimbal Bellows of all sizes. The FEA report shall be submitted for approval of GA drawings. However, if the FEA of same sized bellows with similar parameters have been carried out, then test reports of same can be submitted for the approval of GA drawings. But, these reports shall not be older than 10 (ten) years from the date of placement of purchase order.
- 4.5 The expansion bellows shall be designed for the deflections indicated in GA drawing. The spring rates of the bellow expansion joint shall be within +15% to -30% of the values specified in GA drawing.
- 4.6 Designed cycle life of the expansion bellows shall be minimum of 10,000 cycles.
- 4.7 Stress relieving or annealing/heat treatment after forming of bellows is not recommended.
- 4.8 No pre-tension of bellows is permitted.

	<b>TECHNICAL SPECIFICATION METAL EXPANSION BELLOWS</b>  <b>2X660MW KHURJA STPP (TG PKG)</b>	SPECIFICATION NO. PE-TS-475-100-M021 REV-00	
		DATE: 07/10/2021	SECTION-I
		SPECIFIC TECHNICAL REQUIREMENTS	SHEET 2 OF 7

## 5. MATERIAL

- 5.1 The material of construction of bellows shall be as indicated in Data sheet and GA drawings.
- 5.2 The materials of construction of the remaining parts shall be to suit service conditions. These materials shall be subject to approval of the BHEL.
- 5.3 Materials used in manufacturing of bellows shall be of tested quality.

## 6. CONSTRUCTIONAL FEATURES

### 6.1 METALLIC BELLOWS

- a) The bellows shall be manufactured by hydraulic forming, roll forming or any other method specified in latest edition of EJMA. They should be formed from perfect cylinders of single ply, 304 grade stainless steel.
- b) The number of longitudinal weld seam shall be minimum & Circumferential welding of elements to make bellows is not permitted. The welding procedure and welder qualification shall be as per ASME Section IX.
- c) All bellow elements shall be pickled after forming.
- d) Butt welded expansion joints shall have adequate length of pipe so that site welding does not impair or reduce the metallic expansion bellows efficiency.
- e) Bidder to ensure that thinning due to forming shall be less than 15%.

### 6.2 SLEEVES & SHROUDS

- a) Expansion joints will be furnished with sleeves of the same material as the bellows and installed with sufficient clearance to allow full rated deflection. The sleeves shall be welded on the flow inlet end of the bellows only. The sleeves shall also be provided with a drain hole wherever necessary to avoid condensate accumulation.
- b) Bellows shall have shrouds with an arrow indicating the direction of flow on the outside. These are the external steel covers provided to protect bellows from physical damages during shipping, installation and while in operation. The arrangement of shrouds shall be suitable for supporting insulation where necessary and shall be detachable. Shrouds shall not restrict the free deflection of bellows.

### 6.3 TIE BARS & LIMIT RODS

- a) Untied expansion joints shall have a minimum of two limit rods across the bellows to prevent the bellows from closing/opening under vacuum / pressure beyond limit.
- b) Tied lateral angular expansion joints shall be provided with two tie rods to take care of vacuum/pressure thrust. These tie rods shall have spherical washers with sufficient clearances in flange holes to accommodate lateral deflections of bellows. These bellows shall be capable of taking care of angulation in one plane.
- c) Spherical washers/hinges should have a low coefficient of friction preferably with P.T.F.E. lining.
- d) Bellows shall be provided with complete round flanges housing the tie rods/ limit rods.

	<b>TECHNICAL SPECIFICATION METAL EXPANSION BELLOWS</b>  <b>2X660MW KHURJA STPP (TG PKG)</b>	SPECIFICATION NO. PE-TS-475-100-M021 REV-00	
		DATE: 07/10/2021	SECTION-I
		SPECIFIC TECHNICAL REQUIREMENTS	SHEET 3 OF 7

#### 6.4 HINGE & GIMBAL COMPONENTS

- a) Hinged bellows shall be provided with hinge plates and hinge pin permitting the bellows for angular rotation about one plane while taking care of pressure thrust.
- b) Gimbal bellows shall have a gimbal ring, which is square (as indicated in standard GA drawing) with hinge plates and pins allowing the bellows to angulate in both planes while taking care of pressure thrust.

### 7. QUALITY ASSURANCE, TESTING AND INSPECTION

- 7.1 The items covered under this contract shall be subjected to inspection, testing and quality surveillance. The Inspection Agency shall, at all reasonable times have access to Vendor's works, Quality Control records and all facilities as reasonably required for carrying out the inspection and testing efficiently, and these shall be provided by the vendor free of cost.
- 7.2 The Quality Plan enclosed with this specification specify minimum quality control requirement. During contract stage, vendor shall furnish this Quality Plan duly signed & stamped for BHEL approval. The final quality plan may incorporate some changes based on BHEL's customer comments (if any). Quality plans shall be approved by BHEL and/or the customer. All inspection and testing shall be carried out by BHEL/ BHEL representative and the customer (as applicable). In case, inspection is by both BHEL and the customer, then the inspection can be carried out jointly or separately, which will be informed accordingly. In case of the foreign bidder, inspection shall be carried out by reputed third party.
- 7.3 For foreign bidders, charges for third party inspection (Lloyds, TUV or equivalent) shall be included in the base price of the item by the bidder. This third party agency shall be approved by BHEL. Bidder to inform the same in the offer and mention the same in Quality Plan.

**Note:** There may be some changes in quality plan depending on customer/consultant comments which will have to be accommodated by vendor at no extra cost.

- 7.4 Bellows shall be subject to all test and inspection required by the applicable codes and standards as per quality plan and those specified below. The vendor shall fully shop assemble the expansion bellow and perform test to demonstrate that its performance is as specified:
  - a) All welds shall be dye-penetrant tested as per ASTM E-165/ASME SEC-V. Post cleaning of dye penetrant shall be taken care.
  - b) Material test certificates for both chemical and mechanical properties as per the relevant code shall be furnished.
  - c) The expansion bellow shall be assembled and hydro-statically tested with calibrated gauge at shop at 1.5 times the design pressure for a period of half-an hour.
  - d) The expansion bellow shall be subject to vacuum test with calibrated gauge at the shop at a pressure of 50 mmHg (abs) for a period of half-an hour.
  - e) All attachment welds and fillet welds in the bellow assembly shall be either magnetic particle tested or dye-penetrant tested or as per quality plan.
  - f) Axial spring rate test (stiffness test) for verifying actual spring rate with theoretical value with a tolerance of +15% to -30%.

	<b>TECHNICAL SPECIFICATION METAL EXPANSION BELLOWS</b>  <b>2X660MW KHURJA STPP (TG PKG)</b>	SPECIFICATION NO. PE-TS-475-100-M021 REV-00	
		DATE: 07/10/2021	SECTION-I
		SPECIFIC TECHNICAL REQUIREMENTS	SHEET 4 OF 7

- g) Deflection test is to ensure that the bellow deflect for the designed movement in any direction when induced individually or simultaneously without any obstruction. Deflection test shall be carried out considering the effects of combined movement of axial, lateral and angular (equivalent axial movement per convolution shall be calculated as per EJMA).
- h) Examination of radiography including radiographic techniques, radiographic examination of the longitudinal seam of the bellows should be performed before the bellow is convoluted. No lack of fusion is allowed. The test procedures shall be as per ASME SEC-V & acceptable norms as per ASME SEC VIII.
- i) Test will be witnessed by the customer / consultants/ BHEL unless otherwise waived.

## 8. TYPE TESTS (CYCLE LIFE, SQUIRM AND YIELD RUPTURE TESTS)

- 8.1 Type tests as per EJMA are required to be carried out for bellows. These shall be done as per classification given below:

Based on Diameter of Bellows: The categories are as follows:

- Nominal diameter up to and including 800mm NB.
- Nominal diameter greater than 800mm NB & up to and including 1600 NB.
- Nominal diameter greater than 1600mm NB & up to and including 2400 NB.

- 8.2 If type tests have been successfully done for earlier BHEL projects for the bellows of the same type\* in a group (as indicated in cl. 8.1 above), then test certificates of same will be reviewed and no type test needs to be carried out. But, these test certificates shall not be older than 5 (five) years from the date of placement of project specific Purchase order. However, in this case, type test clearance shall be taken from BHEL prior to offering to routine test. In case no type test has been conducted for earlier projects or type test reports are older than 5 years, type test shall be carried out and type test procedure approval shall be taken from BHEL prior to offering to routine test.

Final decision regarding conductance of type test will be conveyed by BHEL at a later date after award of contract, which will be binding on the bidder without commercial implication.

**Note: 1) Same type\* means bellows having same height, pitch, general shape of convolution profile, ply thickness and type of bellow materials.**

**2) If Type Tests & FEA are required to be carried out in line with technical specification, then the charges for the same shall deemed to be included in the unit quoted prices of main item and shall not be indicate as a separate head in the price bid.**

### 8.3 CRITERIA OF TEST

Type tests, as per EJMA, shall be carried out on two bellows of any size from each group of bellows (as per clause 8.1 above). One bellow shall be used for life cycle test and the other for Squirm & Yield rupture test. Accordingly, all the bellows of the group shall be qualified on the basis of this test.

### 8.4 NO. OF CYCLES

For the life cycle test, the number of test cycles shall be minimum 10,000 cycles. The squirm and yield pressure shall be as per approved pressure and calculations.

	<b>TECHNICAL SPECIFICATION METAL EXPANSION BELLOWS</b>  <b>2X660MW KHURJA STPP (TG PKG)</b>	SPECIFICATION NO. PE-TS-475-100-M021 REV-00	
		DATE: 07/10/2021	SECTION-I
		SPECIFIC TECHNICAL REQUIREMENTS	SHEET 5 OF 7

#### 9. PAINTING REQUIREMENT:

Painting for metal expansion bellows shall be done as per details given below:

SERVICE	SURFACE CLEANING	PAINTING DETAIL	COLOUR SHADE
Condensate suction line	SP3, Power tool cleaning	Bellows first shall be painted with two coats of Red Oxide Zinc Phosphate primer (Alkyd base) with each coat of DFT equal to 25 microns conforming to IS 12744. Finish paint shall be three coats (DFT 35 microns each coat) of synthetic enamel paint (long oil alkyd) as per IS: 2932. Total DFT of primer and paint shall be 155 microns.	As per IS 5 Sea green shade no. ISC -217
Flash Tank Vents	SP3, Power tool cleaning	2 coats (Total DFT 40 µm) of heat resistant Aluminium paint to IS 13183 Gr.III	Aluminium
TD BFP Exhaust	SP3, Power tool cleaning	2 coats (Total DFT 40 µm) of heat resistant Aluminium paint to IS 13183 Gr.III	Aluminium

#### 10. CLEANING

- 10.1 All parts which are not made of stainless steel or other corrosion resisting materials shall be cleaned, flushed and coated with anti-corrosive paints of approved make and quality before shipment. Before painting, the surfaces shall be thoroughly cleaned of grease, dirt etc.
- 10.2 Prior to inspection and shipment, the expansion bellows shall be cleaned from inside and outside to remove all manufacturing wastes, scrap, mill scale, rust, etc.
- 10.3 Each expansion bellows shall be prepared for shipment in such a manner that the quality, cleanliness and finish shall be maintained during shipment.

#### 11. PROTECTION, PACKING & DESPATCH

- 11.1 Each expansion bellows shall be fitted with a 2 mm thick rectangular stainless steel name plate indicating the following:
- Manufacturer's Name
  - Expansion Joint Size & Type
  - Tag No.
  - Assembly Weight.
- All detail shall be engraved 1 mm deep and filled with black enamel paint
- 11.2 Bellows Tag Number shall be incorporated in all the dispatch documents.
- 11.3 Exposed finished surface of metal expansion bellows shall be thoroughly greased before transportation and suitably protected in such a way so as to minimize the possibility of damage and deterioration during transit and storage.
- 11.4 The bellows has to be dispatched in total assembled form and shall be shipped at neutral length. They shall be provided with suitable erection and knock-off type temporary tie rods/ shipping brackets, wherever required, to prevent damage and misalignment during transit. These rods shall be tagged with instruction that they are to be left in place during erection but shall be removed before the system is placed in operation. These rods shall be provided in yellow colour.
- 11.5 Proper care shall be taken to avoid damage to the painted surface during transit and storage.

	<b>TECHNICAL SPECIFICATION METAL EXPANSION BELLOWS</b>  <b>2X660MW KHURJA STPP (TG PKG)</b>	SPECIFICATION NO. PE-TS-475-100-M021 REV-00	
		DATE: 07/10/2021	SECTION-I
		SPECIFIC TECHNICAL REQUIREMENTS	SHEET 6 OF 7

- 11.6 Expansion joints weighing more than 250kgs are to be provided with lifting lugs.
- 11.7 Bellows shall be packed in following manner:
- First layer of hessian cloth.
  - Second layer of bubble sheet wrapping.
  - Third layer of stretch sheet wrapping.
  - Wrapped Bellows up to 1200 NB (inclusive) size shall be packed in wooden box suitable for handling and storage.
  - Wrapped Bellows above 1200 NB shall be placed in wooden box suitable for storage purpose. The box shall have clear marking that “The bellows to be handled separately from box.”
  - The wooden boxes shall be suitable for storage at site in tropical climate conditions for a period of 15-18 months.
- 11.8 Vendor to provide soft copy of photos/snaps of duly packed ME Bellows. The soft copies to be provided by vendor to BHEL after final inspection of ME Bellows.
- 11.9 Clearance for dispatch of ME Bellows will be given only after verification of satisfactory packing conditions of ME Bellows from vendor’s works.

## 12. DOCUMENTS TO BE SUBMITTED ALONG WITH OFFER

Bidder shall submit the following documents duly filled, signed and stamped along with the bid:

- Compliance sheet
- Documents as per the list indicated in the NIT

The above are the only documents which will be used for technical evaluation unless other documents are asked for during technical clarifications. Any other technical document enclosed with the bid shall be ignored for the purpose of technical evaluation. All other documents attached with the specification are for information of the bidder and no comments shall be marked on these.

## 13. DOCUMENTS TO BE SUBMITTED AFTER AWARD OF PROJECT:

### Category-A (Primary Documents):

- GA Drawing indicating all necessary dimensions (with tolerance as per EJMA), cross sectional arrangement, arrangement of tie rods or limit rods or hinge arrangement or gimbal arrangement as applicable, along with washers, nuts, pins, arrangement of sleeves and shroud, bill of material incorporating all material of construction (MOC) of various parts & relevant standard to which MOC confirms to and total weight, welding standards and welding details, flange details/butt weld end details, design deflections, stiffness rates for each bellow and painting detail.
- Quality plan duly signed and stamped.

Submission and resubmission of the above documents shall be considered for delay analysis by BHEL.

501929/2021/PS-PEM-MPL

	<b>TECHNICAL SPECIFICATION METAL EXPANSION BELLOWS</b>  <b>2X660MW KHURJA STPP (TG PKG)</b>	SPECIFICATION NO. PE-TS-475-100-M021 REV-00	
		DATE: 07/10/2021	SECTION-I
		SPECIFIC TECHNICAL REQUIREMENTS	SHEET 7 OF 7

**Category-B (Secondary Documents):**

1. Type Test reports in accordance with clause No. 8 of technical specification

Or

Type test procedures (if type test is not performed/ Valid type test report is not available).

2. Axial spring rate test procedure for ME bellows.
3. Project specific, routine test procedure (hydro, vacuum and deflection) for ME bellows.

Approval on these documents shall be obtained before final inspection.

**14. EXCLUSIONS**

Erection & commissioning at site are excluded from the bidder's scope.

	<b>TECHNICAL SPECIFICATION METAL EXPANSION BELLOWS</b>  <b>2X660MW KHURJA STPP (TG PKG)</b>	SPECIFICATION NO. PE-TS-475-100-M021 REV-00	
		DATE: 07/10/2021	SECTION-II
		DATA SHEET- PART-1	SHEET 1 OF 1

## SECTION-II

### DATA SHEET

#### PART-1: BOQ FOR METAL EXPANSION BELLOWS

SL. NO.	ITEM DESCRIPTION			TOTAL QTY
	SIZE (NB)	TYPE	TAG NO.	
1	1800	GIMBAL BELLOWS	E1, E2, E4 & E5	8
2	1800	HINGED ANGULAR BELLOWS	E3 & E6	4
3	800	HINGED ANGULAR BELLOWS	E8 & E10	4
4	800	TIED LATERAL ANGULAR BELLOWS	E7 & E9	4
5	450	UNTIED BELLOWS	E11, E12 & E13	6
6	300	UNTIED BELLOWS	E14, E15, E16 & E17	8

NOTE: If Type Tests & FEA are required to be carried out in line with technical specification then the charges for the same shall be deemed to be included in the unit quoted prices of main item. Bidder shall not indicate these charges as a separate head in the price bid.

	<b>TECHNICAL SPECIFICATION METAL EXPANSION BELLOWS</b>  <b>2X660MW KHURJA STPP (TG PKG)</b>	SPECIFICATION NO. PE-TS-475-100-M021 REV-00	
		DATE: 07/10/2021	SECTION-II
		DATA SHEET- PART-2	SHEET 1 OF 1

**DATA SHEET****PART-2: GENERAL CONSTRUCTIONAL DETAIL**

SL. NO.	CONSTRUCTIONAL DETAIL	GIMBAL	HINGED	HINGED	TIED	UNTIED	UNTIED
	<b>BELLOWS SIZE (NB)</b>	<b>1800</b>	<b>1800</b>	<b>800</b>	<b>800</b>	<b>450</b>	<b>300</b>
1	PIPE SIZE (OD X THK)	1829X16	1829X16	813X10	813X10	457X9.53	323.9X9.53
2	ASSEMBLY TYPE	SINGLE	SINGLE	SINGLE	UNIVERSAL	UNIVERSAL	UNIVERSAL
3	OVERALL LENGTH (MM)	1100	900	800	1198	600	500
4	PLY THICKNESS (MM)	1.2	1.2	1	1	0.6	0.6
5	BELLOWS WIDTH (MM)	47	47	37	37	20	20
6	BELLOWS PITCH(MM)	40	40	28	28	20	20
7	CONVOLUTION	8	8	5	8+8	5+5	5+5
8	TANGENT THICKNESS (MM)	1.2	1.2	1	1	0.6	0.6
9	TANGENT LENGTH (MM)	20	20	20	20	20	20
10	COLLAR THICKNESS (MM)	2	2	1	1	1	1
11	COLLAR LENGTH (MM)	20	20	20	20	20	20
12	SPOOL/MID PIPE LENGTH (MM)	NA	NA	NA	350	150	90
13	SLEEVE THICKNESS (MM)	10	10	6	6	1.5	1.5
14	ROUND FLANGE THICKNESS (MM)	55	55	30	30	20	16
15	SQUARE GIMBAL RING THICKNESS (MM)	60	NA	NA	NA	NA	NA
16	SQUARE GIMBAL RING WIDTH (MM)	325	NA	NA	NA	NA	NA
17	HINGE MAIN PLATE THICKNESS (MM)	NA	60	30	NA	NA	NA
18	HINGE SUPPORT PLATE THICKNESS (MM)	28	28	15	NA	NA	NA
19	HINGE PIN/GIMBAL PIN DIA. (MM)	70	70	30	NA	NA	NA
20	GUSSET PALTE THICKNESS (MM)	30	30	15	NA	NA	NA
21	TIE ROD DIA. (MM)	NA	NA	NA	42	30	25
22	TIE ROD LENGTH (MM)	NA	NA	NA	1300	600	490
23	THICKNESS OF END PIPE LOCAL TO FLANGE (MM)*	22	22	NA	NA	NA	NA

**NOTE:**

- (\*) Thickness of end pipe local to flange to be as specified. It is to be step machined equal to pipe thickness near the bellows convolution and edge prepared to suit matching pipe ID at other end.
- Thickness of pressure parts indicated are minimum requirements and the same shall be as per Finite Element Analysis.

501929/2021/PS-PEM-MPL





	<b>TECHNICAL SPECIFICATION METAL EXPANSION BELLOWS</b>  <b>2X660MW KHURJA STPP (TG PKG)</b>	SPECIFICATION NO. PE-TS-475-100-M021 REV-00	
		DATE: 07/10/2021	SECTION-II
		DATA SHEET- PART-3	SHEET 1 OF 1

**DATA SHEET****PART-3: MATERIAL OF CONSTRUCTION DETAIL**

SL. NO	PART NAME	MATERIALS FOR BELLOWS/PRESSURE PARTS/OTHER ATTACHMENTS
1	BELLOWS	ASTM 240 TP 304
2	INTERNAL SLEEVE	ASTM 240 TP 304
3	COLLAR	ASTM 240 TP 304
4	END PIPE/MID PIPE OR SPOOL PIPE	SA 672 GR.B 70/ SA 672 GR.C 70/ SA515 GR. 70/516 GR.70/SA106GR.B
5	HINGE PLATE SUPPORT FLANGE/HOUSING FLANGE/RING	IS 2062 GR.B/ SA515 GR. 70/516 GR.70
6	HINGE PIN / GIMBAL PIN	CARBON STEEL CL.8.8
7	GIMBAL PLATE	SA515Gr.70 /SA516Gr.70/ IS2062Gr.B
8	HINGE MAIN PLATE	SA515Gr.70 /SA516Gr.70/ IS2062Gr.B
9	HINGE SUPPORT PLATE	SA515Gr.70 /SA516Gr.70/ IS2062Gr.B
10	GUSSET PLATE	SA515Gr.70 /SA516Gr.70/ IS2062Gr.B
11	TIE ROD/LIMIT ROD WITH NUT & LOCKNUT	CARBON STEEL (CL. 6.8 & 6.0)
12	SPHERICAL WASHER	SA515Gr.60/ SA515Gr.70 /SA516Gr.60/SA516Gr.70
13	EXTERNAL SLEEVE/COVER/SHROUD & SHROUD SUPPORT	IS 2062 Gr. A/B
14	CIRCLIPS/WASHER	MILD STEEL
15	BOLT & NUT	IS1367 CL6.8/6.0
16	ANY OTHER COMPONENT	SPECIFIED BY BIDDER AND SHALL BE SUITABLE FOR INTENDED DUTY

	<b>MANUFACTURER/ BIDDER/ SUPPLIER NAME &amp; ADDRESS</b>	<b>QUALITY PLAN</b>			SPEC. NO : PE-TS-475-100-M021 REV-00	DATE: 07.10.2021
		CUSTOMER : THDC INDIA LIMITED.			QP NO.: PE-QP-475-100-M021 REV-00	DATE: 07.10.2021
		PROJECT: 2X660MW KHURJA STPP (TG PKG)			PO NO.:	DATE:
		ITEM: ME BELLOWS	SYSTEM: POWER PIPING	SECTION: II	SHEET 1 OF 6	

Sl No.	COMPONENT & OPERATIONS	CHARACTERISTICS	CLASS	TYPE OF CHECK	QUANTUM OF CHECK		REFERENCE DOCUMENT #	ACCEPTANCE NORMS	Format of RECORD		Agency			REMARKS
					M	C/N			9	*	**			
<b>1.0 RAW MATERIAL</b>														
1.1	MATERIAL FOR BELLOWS AND ASSEMBLY PARTS (SHEET/ PIPE / PLATES/ ROD / BAR )	CHEMICAL COMPOSITION	MA	CHEMICAL ANALYSIS	ONE PER BATCH/LOT/HEAT		APPROVED DRAWING	MTC (or) CHECK TEST CERTIFICATE	√	P	V	V	CORELATED TC W.R.T HEAT/BATCH/LOT TO BE REVIEWED BY BHEL QC.  REFER NOTE NO:3	
		MECHANICAL PROPERTIES		UTS, YS & PERCENTAGE OF ELONGATION MEASUREMENT	ONE PER BATCH/LOT/HEAT				√	P	V	V		
		DIMENSIONAL CHECK		100 %	100 %	-			P	V	V			
		SURFACE EXAMINATION	MI	VISUAL	100 %	100 %			-	P	V	V		
<b>2.0 WELDING</b>														
2.1	1) WELDING PROCEDURE	CORRECTNESS OF PROCEDURE	CR	VERIFICATION OF WPS	100 %		IS 7307 / ASME SEC IX	IS 7307 / ASME SEC IX	IS 7307 / ASME SEC IX	√	P	V	V	REFER NOTE NO: 4
	2) PROCEDURE QUALIFICATION	WELD SOUNDNESS		DESTRUCTIVE TESTS	100%					√	P	V	V	
	3) WELDER PERFORMANCE QUALIFICATION	WELDERS' PERFORMANCE		DESTRUCTIVE TESTS / NON DESTRUCTIVE TEST OF A TEST COUPON	100%					IS 7310 / ASME SEC IX	IS 7310 / ASME SEC IX	IS 7310 / ASME SEC IX	√	

BHEL					
ENGINEERING			QUALITY		
Prepared by:	Sign & Date	Name	Checked by:	Sign & Date	Name
Prepared by:	 DATED 11.10.21	GAURAV DIXIT	Checked by:		ASHISH PANIGRAHI
Reviewed by:		SWETA SINGHAL	Reviewed by:		R K JAISWAL

BIDDER/VENDOR	
Sign & Date	Seal

FOR CUSTOMER REVIEW & APPROVAL			
Doc No:	Sign & Date	Name	Seal
Reviewed by:			
Approved by:			

	<b>MANUFACTURER/ BIDDER/ SUPPLIER NAME &amp; ADDRESS</b>	<b>QUALITY PLAN</b>				SPEC. NO : PE-TS-475-100-M021 REV-00	DATE: 07.10.2021
		CUSTOMER : THDC INDIA LIMITED.				QP NO.: PE-QP-475-100-M021 REV-00	DATE: 07.10.2021
		PROJECT: 2X660MW KHURJA STPP (TG PKG)				PO NO.:	DATE:
		ITEM: ME BELLOWS	SYSTEM: POWER PIPING	SECTION: II	SHEET 2 OF 6		

SI No	COMPONENT & OPERATIONS	CHARACTERISTICS	CLASS	TYPE OF CHECK	QUANTUM OF CHECK		REFERENCE DOCUMENT	ACCEPTANCE NORMS	FORMAT OF RECORD		AGENCY			REMARKS
					M	C/N			9	D*	M	C	N	
1	2	3	4	5	6		7	8	9		**			
					M	C/N				D*	M	C	N	
2.2	<b>BUTT / GROOVE WELDS</b>													
	1) BELLOWS AND PLATE FORMED PIPES	FITUP, SIZE OF WELD	MA	VISUAL AND MEASUREMENT	100 %	-	APPD DRG / ASME SEC VIII – DIVISION 1	ASME SEC VIII – DIVISION 1	INTERNAL INSPECTION REPORTS	-	P	-	-	
		SOUNDNESS OF WELD	CR	PT FOR BELLOWS LONG SEAM BEFORE FORMING	100 %		ASTM E 165	NO SURFACE DEFECT	INTERNAL INSPECTION REPORTS	-	P	V	V	REVIEW OF FILM BY BHEL & CUSTOMER DURING INSPECTION FOR SL. NO. 3.1
				RT FOR BELLOWS LONG SEAM BEFORE FORMING	100 %		ASME SEC V / APPD. DRG	ASME SEC VIII – DIVISION 1	RT REPORT	√	P	V	V	
				RT FOR PIPE LONG SEAM					RT REPORT	√	P	V	V	
	2) SEGMENTAL FLANGES	SURFACE DEFECTS OF WELDMENTS	MA	PT	100 %	100 %	ASTM E 165	NO SURFACE DEFECT	INTERNAL INSPECTION REPORTS	√	P	V	V	
		INTERNAL DEFECTS OF WELDMENTS		RT	100 %		ASME SEC V	ASME SEC VIII – DIVISION 1	RT REPORT	√	P	V	V	REVIEW OF FILM BY BHEL & CUSTOMER DURING INSPECTION FOR SL. NO. 3.1
		i) FOR THICKNESS 40 MM & BELOW	MA						UT REPORT	√	P	V	V	
		ii) FOR THICKNESS ABOVE 40 MM		UT			ASTM A388 & A435	ASTM A388 & A435	UT REPORT	√	P	V	V	
2.3	FILLET WELDS	SOUNDNESS OF WELDMENTS	MA	PT	100 %		ASME SEC V	ASME SEC VIII – DIVISION 1	INTERNAL INSPECTION REPORTS	√	P	V	V	

BHEL						BIDDER/VENDOR		FOR CUSTOMER REVIEW & APPROVAL			
ENGINEERING			QUALITY			Sign & Date		Doc No:			
Prepared by:	Sign & Date	Name	Checked by:	Sign & Date	Name	Seal		Sign & Date		Name	Seal
Prepared by:		GAURAV DIXIT	Checked by:	Ashish Panigrahi	ASHISH PANIGRAHI						
Reviewed by:	sweta singhal	SWETA SINGHAL	Reviewed by:	RITESH KUMAR JAISWAL	R K JAISWAL						

	<b>MANUFACTURER/ BIDDER/ SUPPLIER NAME &amp; ADDRESS</b>	<b>QUALITY PLAN</b>			SPEC. NO : PE-TS-475-100-M021 REV-00	DATE: 07.10.2021
		CUSTOMER : THDC INDIA LIMITED.			QP NO.: PE-QP-475-100-M021 REV-00	DATE: 07.10.2021
		PROJECT: 2X660MW KHURJA STPP (TG PKG)			PO NO.:	DATE:
		ITEM: ME BELLOWS	SYSTEM: POWER PIPING	SECTION: II	SHEET 3 OF 6	

SL NO	COMPONENT & OPERATIONS	CHARACTERISTICS	CLASS	TYPE OF CHECK	QUANTUM OF CHECK		REFERENCE DOCUMENT	ACCEPTANCE NORMS	FORMAT OF RECORD		AGENCY			REMARKS
					M	C/N				D*	M	C	N	
<b>3.0 INSPECTION &amp; TESTS</b>														
3.1	BELLOWS CONVOLUTIONS	WORKMANSHIP	MA	VISUAL	100 %	APPD. DRG		INTERNAL INSPECTION REPORTS	√	P	W	-		
		DIMENSIONS		MEASUREMENT			√		P	W	V			
		SURFACE DEFECTS (INSIDE & OUTSIDE OF LONG SEAM)		PT		ASTM E 165	NO SURFACE DEFECT		√	P	W	V		
		THINNING		MOCK UP PIECE (or) UT		EJMA	NOT TO EXCEED 15% OF ACTUAL RAW MATERIAL THICKNESS	INTERNAL INSPECTION REPORTS	√	P	W	W		REFER NOTE-6
3.2	FLANGE, SHROUD, SLEEVE, TIE ROD, WASHER & NUTS	WORKMANSHIP & DIMENSIONS	MA	VISUAL & MEASUREMENT	100 %	APPD. DRG		INTERNAL INSPECTION REPORTS	-	P	V	-		
3.3	SEGMENTAL FLANGE	STRESS RELIEVING	MA	REVIEW OF HT CHART	100 %	ASME SEC VIII		SR CHART	√	P	V	V		
3.4	ROUTINE TESTS	1) LEAK TIGHTNESS	CR	1) VACUUM TEST	100 %	1) 50 mm Hg (A)	NO LEAKAGE OR PERMANENT DEFORMATION	TEST REPORTS	√	P	W	W		
				2) HYDROSTATIC PR. TEST		1) APPD. DRG / 1.5 TIMES OF DESIGN PRESSURE			√	P	W	W		
		2) DEFLECTION	CR	DEFLECTION TESTS (EQUIVALENT AXIAL)	100 %	EJMA / APPD. DRG/ APPD. TEST PROCEDURE	EJMA / APPD. DRG/ APPD. TEST PROCEDURE	TEST REPORTS	√	P	W	W		

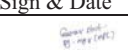
BHEL					
ENGINEERING			QUALITY		
Prepared by:	Sign & Date	Name	Checked by:	Sign & Date	Name
		GAURAV DIXIT			
Reviewed by:	sweta singhal	SWETA SINGHAL	Reviewed by:	RITESH KUMAR JAISWAL	R K JAISWAL

BIDDER/VENDOR	
Sign & Date	Seal

FOR CUSTOMER REVIEW & APPROVAL			
Doc No:	Sign & Date	Name	Seal
Reviewed by:			
Approved by:			

	<b>MANUFACTURER/ BIDDER/ SUPPLIER NAME &amp; ADDRESS</b>	<b>QUALITY PLAN</b>			SPEC. NO : PE-TS-475-100-M021 REV-00	DATE: 07.10.2021
		CUSTOMER : THDC INDIA LIMITED.			QP NO.: PE-QP-475-100-M021 REV-00	DATE: 07.10.2021
		PROJECT: 2X660MW KHURJA STPP (TG PKG)			PO NO.:	DATE:
		ITEM: ME BELLOWS	SYSTEM: POWER PIPING	SECTION: II	SHEET 4 OF 6	

SL NO	COMPONENT & OPERATIONS	CHARACTERISTICS	CLASS	TYPE OF CHECK	QUANTUM OF CHECK		REFERENCE DOCUMENT	ACCEPTANCE NORMS	FORMAT OF RECORD		AGENCY			REMARKS
					M	C/N			D*	M	C	N		
1	2	3	4	5	6		7	8	9		**			
	ROUTINE TESTS	3) SPRING RATE (ONLY AXIAL)	CR	STIFFNESS TEST	ONE/ EACH SIZE AND SPRING RATE OF BELLOW		EJMA / APPD GA DRAWING/ APPROVED TEST PROCEDURE	EJMA / APPD GA DRAWING/ APPROVED TEST PROCEDURE	SPRING RATE CURVES REPORT	√	P	W	W	BELLOWS UNDER NORMAL CONDITION DEFLECTED TO THE VALUE AS SPECIFIED IN. APPD. DRAWING/ APPROVED TEST PROCEDURE
		4) CLEANLINESS	MA	VISUAL	100 %	100 %	APPD. DRG	APPD. DRG	INTERNAL INSPECTION REPORTS	√	P	V	-	
		5)WORKMANSHIP		VISUAL						√	P	V	V	
		6) MARKING		VISUAL						√	P	V	V	
3.5	TYPE TEST	CYCLE LIFE (10000 CYCLES), SQUIRM TEST, YIELD & RUPTURE	CR	DESTRUCTIVE TEST	REFER NOTE NO:1		BHEL/CUSTOMER APPD. TEST PROCEDURES / APPD. GA DRGS	BHEL/CUSTOMER APPD. TEST PROCEDURES / APPD. GA DRGS	TEST REPORTS	√	P	W	W	REFER NOTE NO: 2, 5 & 6
3.6	ASSEMBLY	WORKMANSHIP & DIMENSIONS	MA	VISUAL & MEASUREMENT	100 %	100 %	APPD. DRGS	APPD. DRGS	INTERNAL INSPECTION REPORTS	√	P	W	V	
4.0	PAINTING	SURFACE PREPARATION, PAINT THICKNESS & COLOUR OF PAINT		VISUAL & MEASUREMENT	100%	100%	APPD. DRG	APPD. DRG	INTERNAL INSPECTION REPORTS	√	P	V	V	PHOTOGRAPHS OF BELLOWS AFTER PACKING TO BE SEND TO BHEL-PURCHASE GROUP (PG) FOR VETTING BY BHEL-ENGINEERING BEFORE ISSUING MDCC
5.0	PACKING	SOUNDNESS OF PACKING		VISUAL	100 %	100 %	AS PER NOTE-9	AS PER NOTE-9	INTERNAL INSPECTION REPORTS	√	P	W	V	

BHEL					
ENGINEERING			QUALITY		
Prepared by:	Sign & Date	Name	Checked by:	Sign & Date	Name
		GAURAV DIXIT			
Reviewed by:	sweta singhal	SWETA SINGHAL	Reviewed by:	RITESH KUMAR JAISWAL	R K JAISWAL





BIDDER/VENDOR	
Sign & Date	Seal

FOR CUSTOMER REVIEW & APPROVAL			
Doc No:	Sign & Date	Name	Seal
Reviewed by:			
Approved by:			

	<b>MANUFACTURER/ BIDDER/ SUPPLIER NAME &amp; ADDRESS</b>	<b>QUALITY PLAN</b>		SPEC. NO : PE-TS-475-100-M021 REV-00	DATE: 07.10.2021
		CUSTOMER : THDC INDIA LIMITED.		QP NO.: PE-QP-475-100-M021 REV-00	DATE: 07.10.2021
		PROJECT: 2X660MW KHURJA STPP (TG PKG)		PO NO.:	DATE:
		ITEM: ME BELLOWS	SYSTEM: POWER PIPING	SECTION: II	SHEET 5 OF 6

**NOTES: -**

- In case of foreign supplier, all test certificates shall be furnished by the supplier, duly witnessed/verified by supplier's TPI.
- Life cycle test shall be carried out on one bellow of each group as mentioned in the technical specification.
  - Squirm & Yield – Rupture test shall also be carried out on one bellow (other than the bellow on which life cycle test has been carried out of each group as mentioned below.  
Based on Diameter of Bellows: The categories are as follows:
    - Nominal diameter up to and including 800mm NB.
    - Nominal diameter greater than 800mm NB & up to and including 1600 NB.
    - Nominal diameter greater than 1600mm NB & up to and including 2400 NB.
- For, clause 1.1, in case co related test certificates are not available, check testing shall be carried out by vendor at approved lab (NABL).
- Welding to be done only by qualified welders. For qualified welders, WPS & PQR shall be reviewed by BHEL/Customer.
- If type tests as mentioned at cl.3.5 and note2 above, have been successfully done for earlier BHEL projects for the bellows of the same type (refer note-6) in a group (as indicated above), then only TCs of same shall be reviewed and no type test needs to be carried out. But TC's of the bellows shall not be older than 5 years from the date of placement of project specific Purchase order. However, type test clearance shall be taken from BHEL/Customer prior to offering to routine test. In case the type test is to be done, type test procedure approval shall be taken from BHEL/Customer.
- Bellows of the same type would mean those having the same height, pitch, general shape of convolution profile, ply thickness and type of bellow materials.
- All materials of construction shall be as per approved GA drawing.
- Manufacturing tolerances for fabricated assemblies containing expansion joints shall be as per EJMA/Approved GA drawing.

BHEL						BIDDER/VENDOR		FOR CUSTOMER REVIEW & APPROVAL			
ENGINEERING			QUALITY			Sign & Date		Doc No:			
	Sign & Date	Name		Sign & Date	Name	Seal			Sign & Date	Name	Seal
Prepared by:		GAURAV DIXIT	Checked by:		ASHISH PANIGRAHI						
Reviewed by:		SWETA SINGHAL	Reviewed by:		R K JAISWAL						

	<b>MANUFACTURER/ BIDDER/ SUPPLIER NAME &amp; ADDRESS</b>	<b>QUALITY PLAN</b>		SPEC. NO : PE-TS-475-100-M021 REV-00	DATE: 07.10.2021
		CUSTOMER : THDC INDIA LIMITED.		QP NO.: PE-QP-475-100-M021 REV-00	DATE: 07.10.2021
		PROJECT: 2X660MW KHURJA STPP (TG PKG)		PO NO.:	DATE:
		ITEM: ME BELLOWS	SYSTEM: POWER PIPING	SECTION: II	SHEET 6 OF 6

9. Packing: Bellows shall be packed in following manner:

- a) First layer of hessian cloth, second layer of bubble sheet wrapping and third layer of stretch sheet wrapping.
- b) Wrapped Bellows shall be placed in wooden box suitable handling. Wrapped Bellows up to 1200 NB (inclusive) size shall be packed in wooden box suitable for handling and storage. Wrapped Bellows above 1200 NB shall be placed in wooden box suitable for storage purpose. The box shall have clear marking that "The bellows to be handled separately from box."
- c) The wooden boxes shall be suitable for storage at site in tropical climate conditions for a period of 15-18 months.
- d) Photographs of the wooden box (with LR No.) in which items are finally packed as per approved packing procedure is to submitted to BHEL (wherever applicable) before dispatch. Clearance for dispatch of items will be given only after receipt of above photos.

10. BHEL reserves the right for conducting repeat tests, if required.

11. The latest revision/year of issue of all the standard indicated in the Quality plan shall be referred.

**LEGENDS:**

\*: Records, identified with "Tick"(✓) shall be essentially included by supplier in QA Documentation.

\*\* **M:** Supplier/ Manufacturer/ Sub-Supplier

**C:** Main Supplier/BHEL/ Third Party Inspection agency

**N:** Customer

**P:** Perform

**W:** Witness

**V:** Verification

**MA:** Major Characteristic

**MI:** Minor Characteristic

**CR:** Critical Characteristic





**MTC:** Mill Test Certificate

**PT:** Penetrant Test

**UT:** Ultrasonic Test

**RT:** Radiography Test

**D:** Documentation

BHEL						BIDDER/VENDOR		FOR CUSTOMER REVIEW & APPROVAL			
ENGINEERING			QUALITY			Sign & Date		Doc No:			
	Sign & Date	Name		Sign & Date	Name	Seal		Sign & Date	Name	Seal	
Prepared by:	 DATED 11.10.21	GAURAV DIXIT	Checked by:		ASHISH PANIGRAHI			Reviewed by:			
Reviewed by:	 sweta singhal	SWETA SINGHAL	Reviewed by:		R K JAISWAL			Approved by:			

501929/2021/PS-PEM-MPL

	<b>TECHNICAL SPECIFICATION METAL EXPANSION BELLOWS</b>  2X660MW KHURJA STPP (TG PKG)	SPECIFICATION NO. PE-TS-475-100-M021	
		REV. NO.: 00	DATE: 07.10.2021
		SECTION-II	SHEET 1 OF 1

### COMPLIANCE SHEET

I hereby comply/not comply (\*) to all the requirements of this technical specification in totality.

\* In case the bidder does not comply to the technical specification, the deviations shall be explicitly listed in the technical deviation sheet of GCC. Deviations listed in technical deviation sheet shall only be considered.

**Name of Bidder / Authorized Representative:** - \_\_\_\_\_

**Designation:** - \_\_\_\_\_

**Signature:** - \_\_\_\_\_

**Company Seal:** - \_\_\_\_\_

**Date:** - \_\_\_\_\_

501929/2021/PS-PEM-MPL

	<b>TECHNICAL SPECIFICATION METAL EXPANSION BELLOWS</b>  <b>2X660MW KHURJA STPP (TG PKG)</b>	SPECIFICATION NO. PE-TS-475-100-M021 REV-00	
		DATE: 07/10/2021	SECTION-III
		GA DRAWINGS	

## ANNEXURE-1

### GA DRAWINGS OF ME BELLOWS

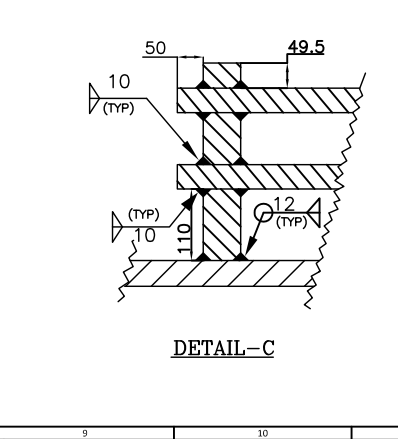
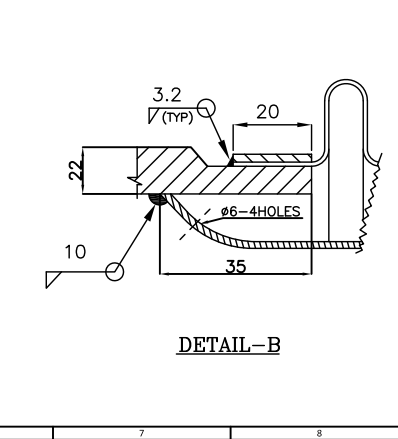
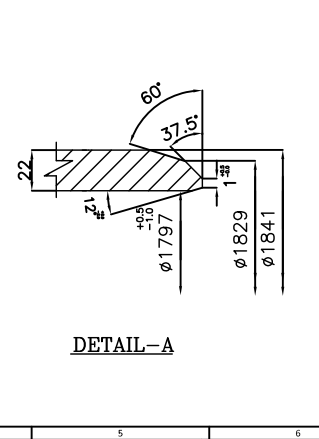
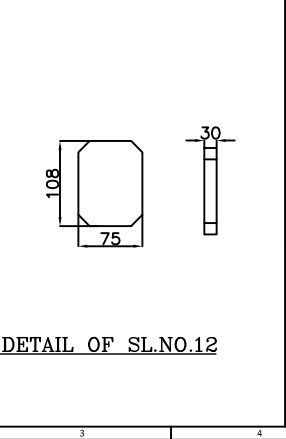
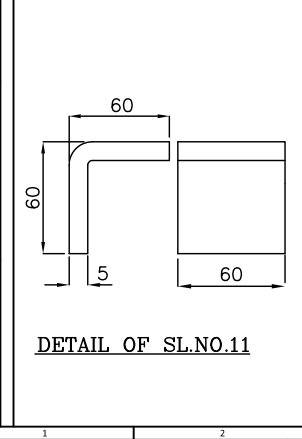
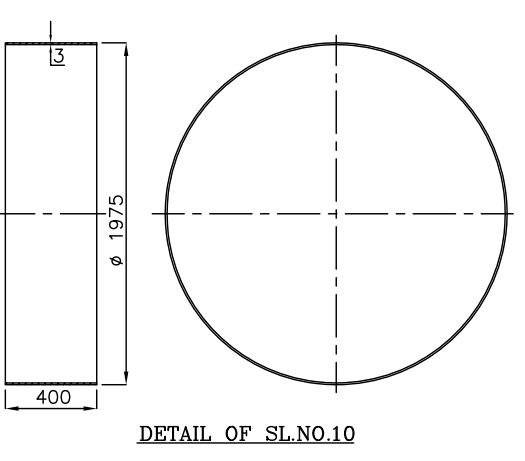
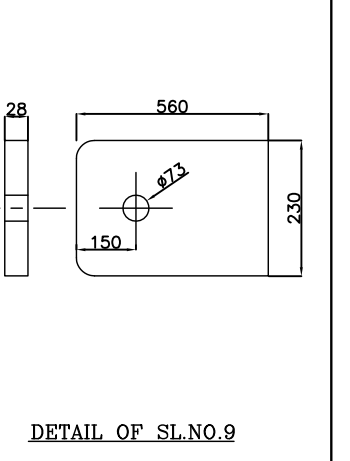
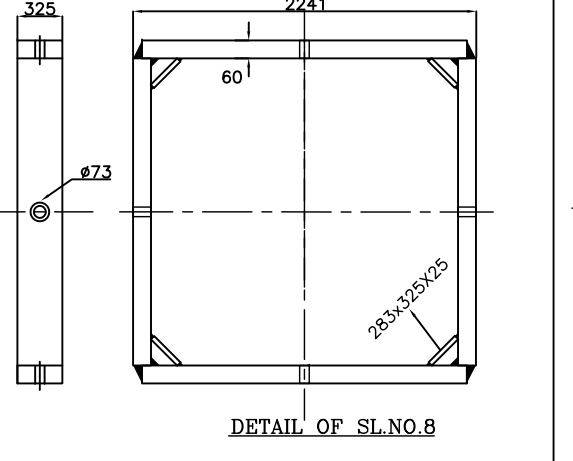
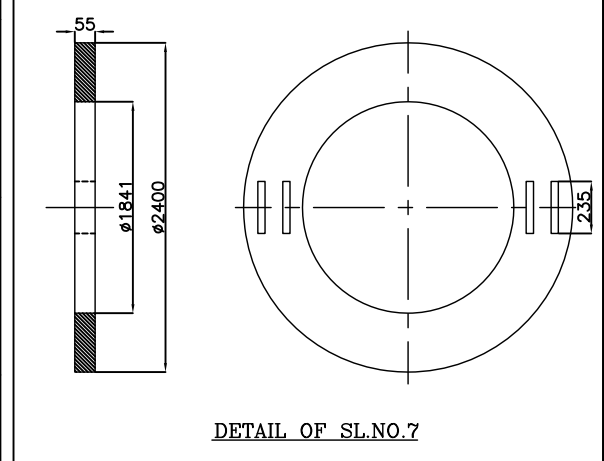
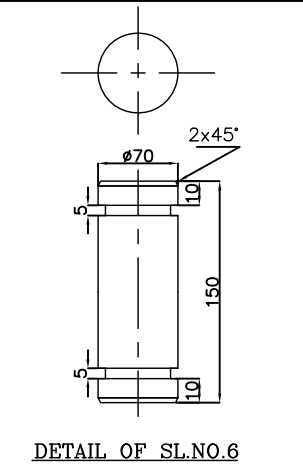
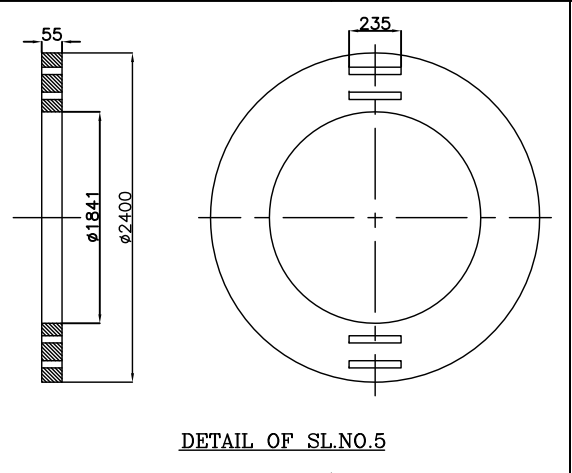
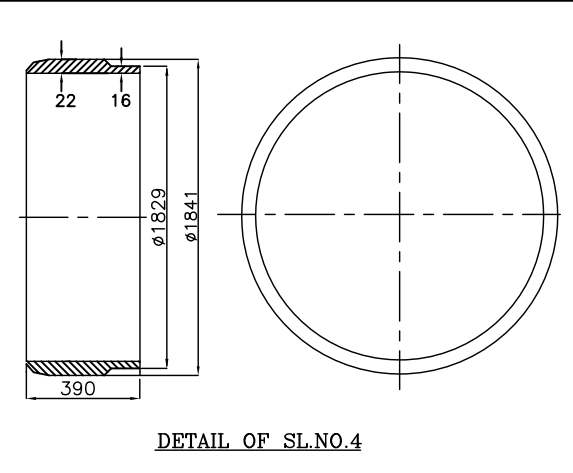
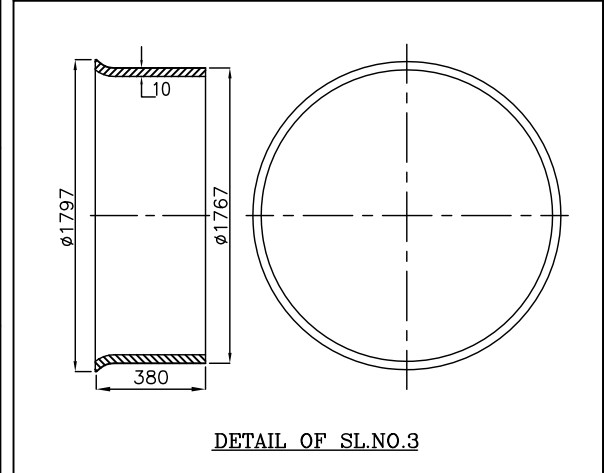
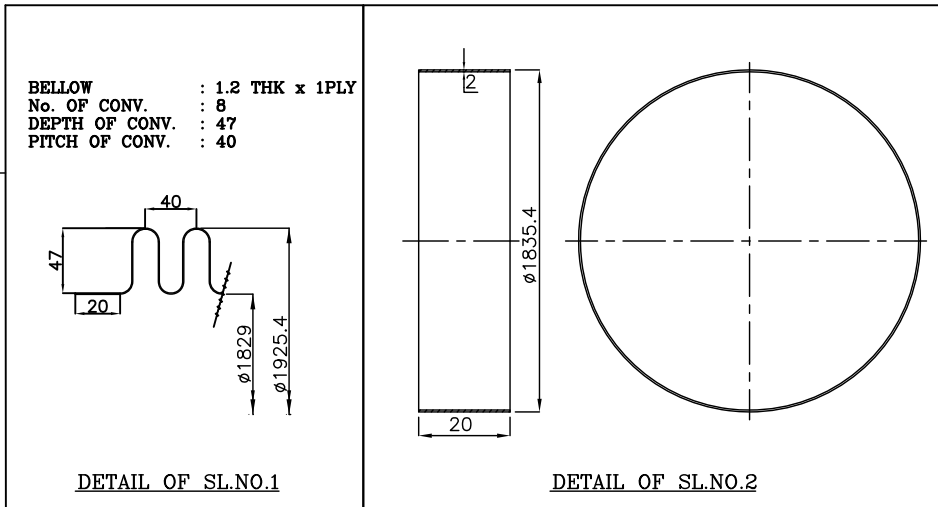
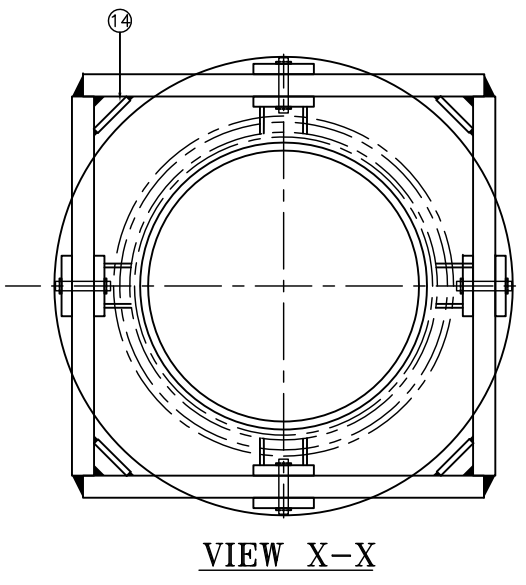
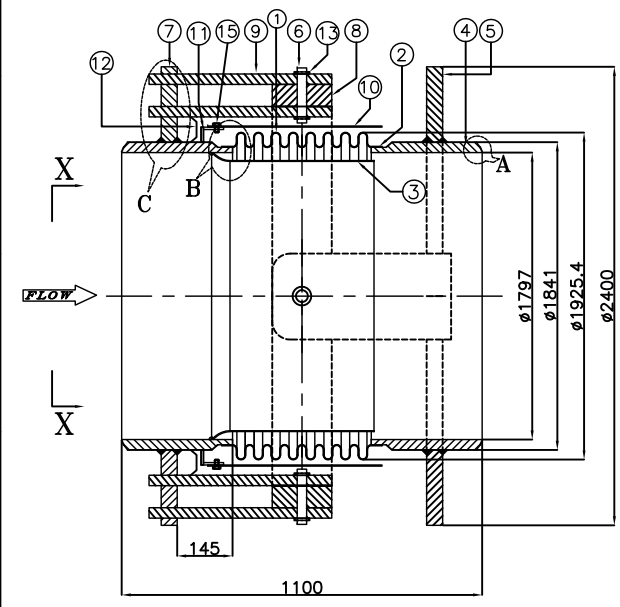

BELLOW DETAILS			
SL NO	DESCRIPTION	UNITS	DATA/PARTICULARS.
1	TAG No.	-	E1,E2,E4 & E5
2	QUANTITIES PER UNIT	Nos.	4
3	TOTAL QUANTITY	Nos.	8
4	LOCATION	-	BFPT A & B EXHAUST TO CONDENSER
5	FLUID	-	STEAM
6	INSTALLATION	-	HORIZONTAL
7	PIPE SIZE(ODxTHK)	mm	1829x16
8	OPERATING PRESSURE	Kg/cm <sup>2</sup> (A)	0.106
9	DESIGN PRESSURE	Kg/cm <sup>2</sup> (g)	1.1
10	HYDRO TEST PRESSURE (FOR 30 Min.)	Kg/cm <sup>2</sup> (g)	1.65
11	VACUUM TEST PRESSURE(FOR 30 Min.)	mm-Hg	50mm of Hg (ABS)
12	OPERATING TEMPERATURE	°C	46.6
13	DESIGN TEMPERATURE	°C	70
14	BELLOW CYCLE LIFE	Nos.	135210
15	ANGULAR DEFLECTION (DESIGN)	DEGREE	3
16	AXIAL SPRING RATE PER CONVOLUTION	Kg/mm	80.16
17	ANGULAR SPRING RATE	Kg-M/Deg.	615.92
18	TOTAL EQUIVALENT MOVEMENT	mm	50.81
19	OVERALL LENGTH	mm	1100
20	BELLOW CONVOLUTED LENGTH	mm	320
21	LIMITING INTERNAL DESIGN PRESSURE BASED ON COLUMN INSTABILITY (P <sub>sc</sub> )	Kg/cm <sup>2</sup>	20.82
22	LIMITING INTERNAL DESIGN PRESSURE BASED ON INPLANE INSTABILITY (P <sub>si</sub> )	Kg/cm <sup>2</sup>	4.31
23	TOTAL STRESS (St)	Kg/cm <sup>2</sup>	7846

BILL OF MATERIAL FOR SINGLE BELLOW			
SL NO	COMPONENT'S NAME	MATERIAL	QUANTITY
1	BELLOWS	SA240TP304	1No
2	COLLAR	SA240TP304	2 Nos.
3	SLEEVE	SA240TP304	1 No.
4	END PIPE	SA672B70/SA672C70/SA515 Gr.70/SA516Gr.70	2 Nos.
5	HINGE SUPPORT FLANGE #1	SA515Gr.70 /SA516Gr.70/ IS2062Gr.B	1 No.
6	HINGE PIN	CARBON STEEL CLASS 8.8	4 Nos.
7	HINGE SUPPORT FLANGE #2	SA515Gr.70 /SA516Gr.70/ IS2062Gr.B	1 No.
8	SQ GIMBAL RING	SA515Gr.70 /SA516Gr.70/ IS2062Gr.B	1 Nos.
9	HINGE SUPPORT PLATE	SA515Gr.70 /SA516Gr.70/ IS2062Gr.B	8 Nos.
10	SHROUD (COVER)	IS 2062 Gr. A/B	1 No.
11	SHROUD (COVER) SUPPORTS	IS 2062 Gr. A/B	4 Nos.
12	GUSSET	SA515Gr.70 /SA516Gr.70/ IS2062Gr.B	8 Nos.
13	CIRCLIP 2mm THK. (DETAIL NOT SHOWN)	MS	8 Nos.
14	STIFFNER	MS	4 Nos.
15	BOLT & NUT-M8	IS 1367 CL6.8/6.0	AR

- NOTES:-**
- BELLOW DESIGN CODE : EJMA LATEST EDITION.
  - WELDING CODE/STD : ASME SEC IX.
  - BUTT WELD DETAIL : AS PER ASME B16.25 TO SUIT MATCHING PIPE.
  - INSPECTION & TESTING : AS PER APPROVED QP.
  - SURFACE PREPARATION: SP3, POWER TOOL CLEANING.
  - PAINTING DETAILS : TWO COATS (TOTAL DFT 40 MICRON) OF HEAT RESISTANT ALUMINUM PAINT TO IS 13183 Gr.III.
  - SUITABLE SHIPPING BRACKETS WILL BE PROVIDED IN YELLOW COLOUR WHICH MUST BE REMOVED AFTER INSTALLATION.
  - STAINLESS STEEL NAME PLATE WITH REQUIRED DETAILS WILL BE FIXED ON EXPANSION JOINTS.
  - ALL DIMENSION ARE IN MM UNLESS OTHERWISE SPECIFIED.
  - EXPANSION JOINTS WEIGHING MORE THAN 250KGS ARE TO BE PROVIDED WITH LIFTING LUGS.
  - DRAWING IS NOT TO SCALE.
  - THICKNESS OF PRESSURE PARTS INDICATED ARE MINIMUM REQUIREMENTS AND THE SAME SHALL BE AS PER FINITE ELEMENT ANALYSIS.

CUSTOMER: **THDC INDIA LIMITED.**

OWNER'S CONSULTANT: **2X660MW KHURJA STPP (TG PKG)**

MANUFACTURER: **BHARAT HEAVY ELECTRICALS LTD**  
POWER SECTOR  
PROJECT ENGINEERING MANAGEMENT  
NOIDA

JOB NO. **475**  
STATUS **CONTRACT**

DISTRIBUTION

REV.	DATE	DSN	CHD	APPD

TITLE: **GIMBAL BELLOWS**  
**SIZE-1800 NB**

ASSEMBLY WEIGHT : **PE-V0-475-100-M171**

TECH. SPEC.No. PE-TS-475-100-M021 R0

DRAWING NO. **PE-V0-475-100-M171**

SHEET **1** OF **6** REV. **00**

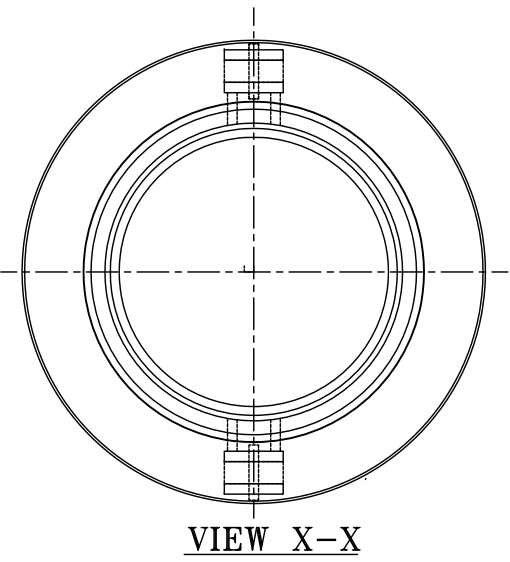
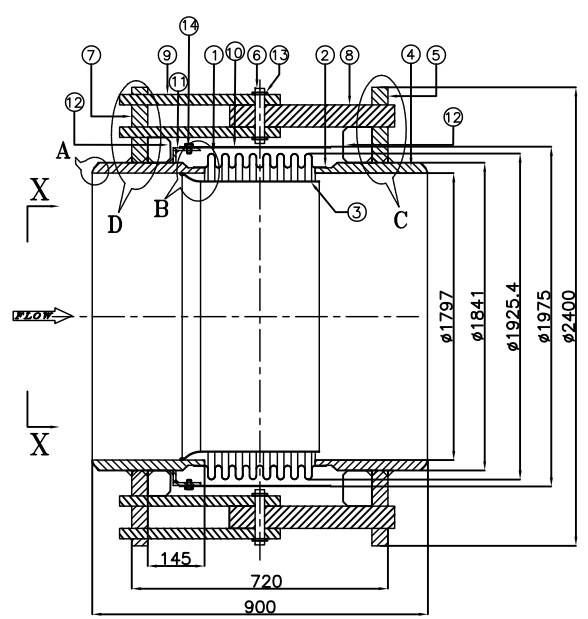

**BELLOW** : 1.2 THK x 1PLY  
**No. OF CONV.** : 8  
**DEPTH OF CONV.** : 47  
**PITCH OF CONV.** : 40

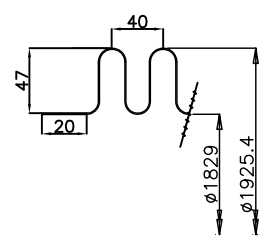

DETAIL OF SL.NO.1

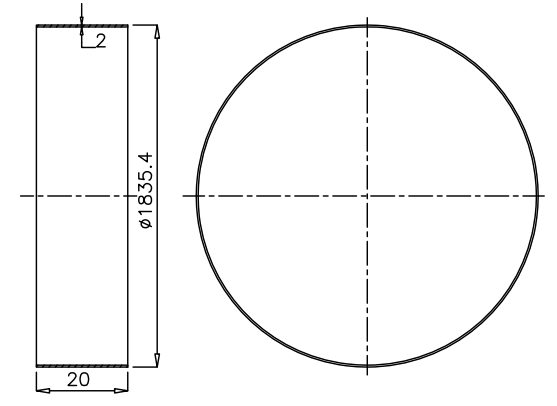

DETAIL OF SL.NO.2

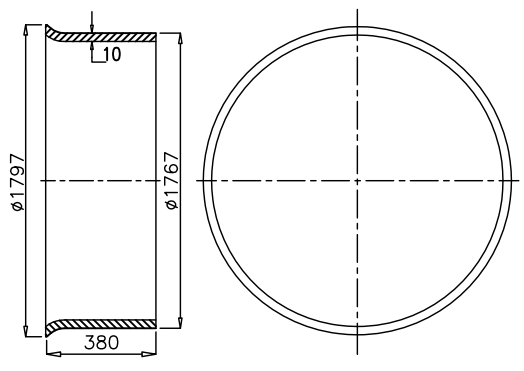

DETAIL OF SL.NO.3

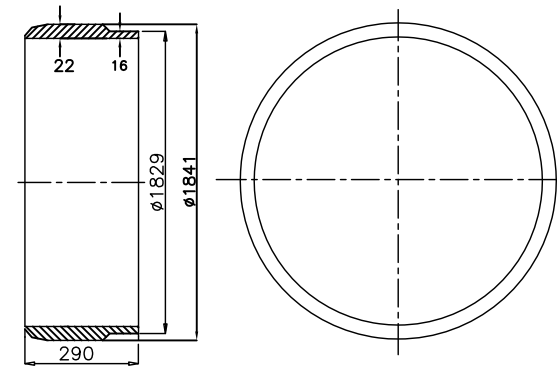

DETAIL OF SL.NO.4

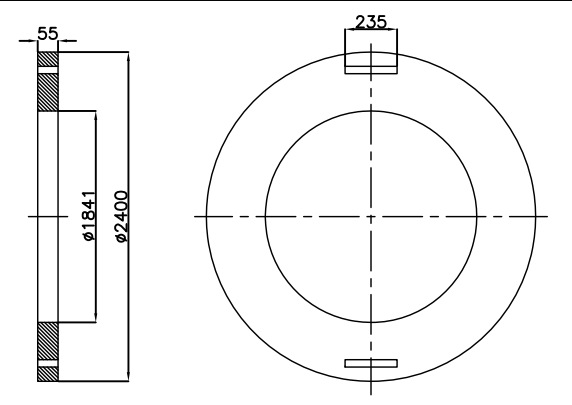

DETAIL OF SL.NO.5

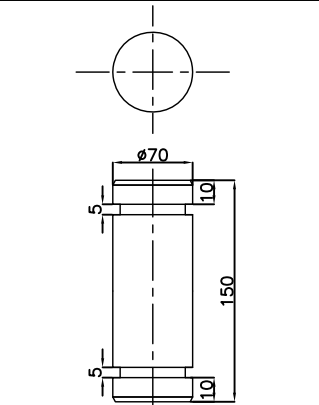

DETAIL OF SL.NO.6

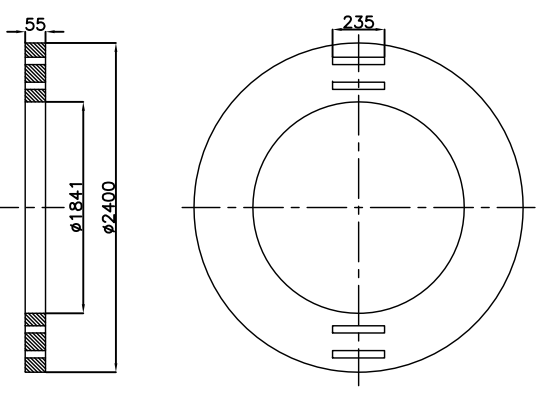

DETAIL OF SL.NO.7

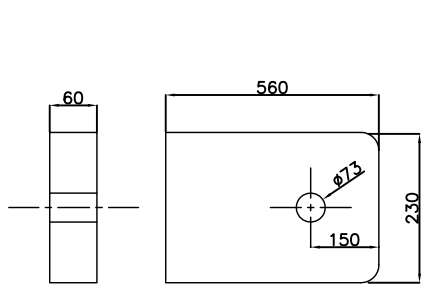

DETAIL OF SL.NO.8

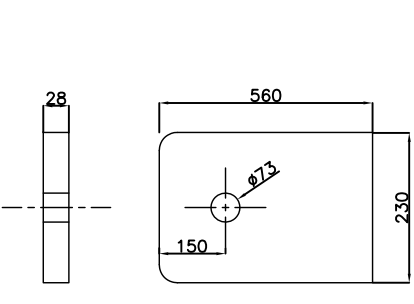

DETAIL OF SL.NO.9

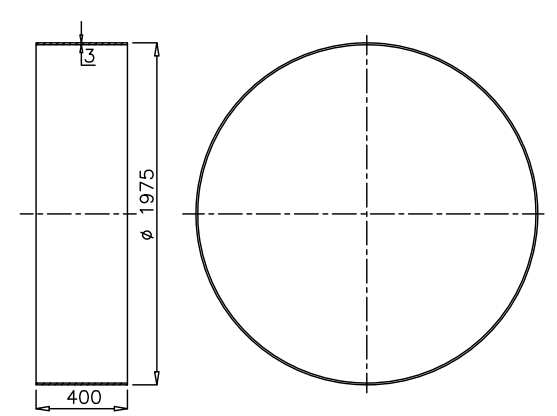

DETAIL OF SL.NO.10

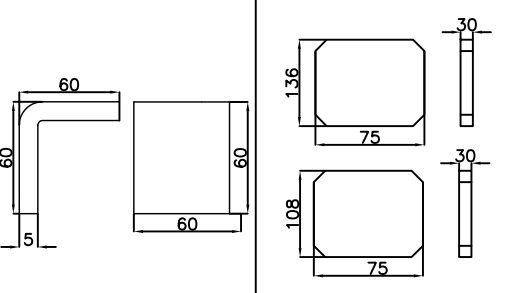

DETAIL OF SL.NO.11

DETAIL OF SL.NO.12

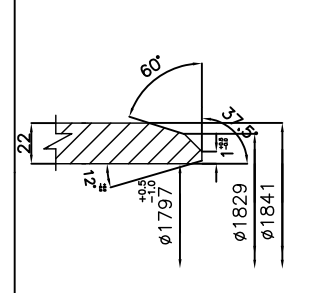

DETAIL-A

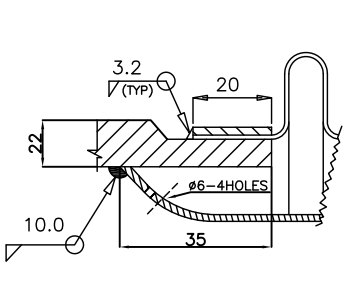

DETAIL-B

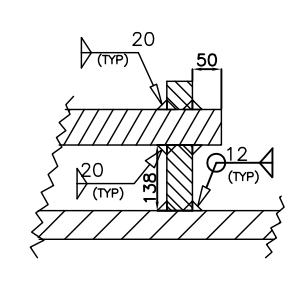

DETAIL-C

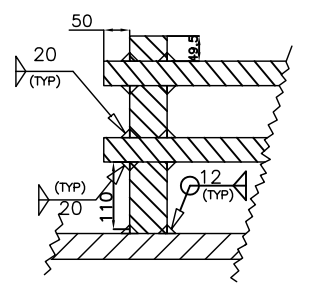

DETAIL-D

BELLOW DETAILS			
SL NO	DESCRIPTION	UNITS	DATA/PARTICULARS.
1	TAG No.	-	E3 & E6
2	QUANTITIES PER UNIT	Nos.	2
3	TOTAL QUANTITY	Nos.	4
4	LOCATION	-	BFPT A & B EXHAUST TO CONDENSER
5	FLUID	-	STEAM
6	INSTALLATION	-	HORIZONTAL
7	PIPE SIZE(ODxTHK)	mm	1829x16
8	OPERATING PRESSURE	Kg/cm <sup>2</sup> (A)	0.106
9	DESIGN PRESSURE	Kg/cm <sup>2</sup> (G)	1.1
10	HYDRO TEST PRESSURE (FOR 30 Min.)	Kg/cm <sup>2</sup> (G)	1.65
11	VACUUM TEST PRESSURE(FOR 30 Min.)	mm-Hg	50mm of Hg
12	OPERATING TEMPERATURE	°C	46.6
13	DESIGN TEMPERATURE	°C	70
14	BELLOW CYCLE LIFE	Nos.	135210
15	ANGULAR DEFLECTION (DESIGN)	DEGREE	3
16	AXIAL SPRING RATE PER CONVOLUTION	Kg/mm	80.16
17	ANGULAR SPRING RATE	Kg-M/Deg.	615.92
18	TOTAL EQUIVALENT MOVEMENT	mm	50.81
19	OVERALL LENGTH	mm	900
20	BELLOW CONVOLUTED LENGTH	mm	320
21	LIMITING INTERNAL DESIGN PRESSURE BASED ON COLUMN INSTABILITY (Psc)	Kg/cm <sup>2</sup>	20.82
22	LIMITING INTERNAL DESIGN PRESSURE BASED ON INPLANE INSTABILITY (Psi)	Kg/cm <sup>2</sup>	4.31
23	TOTAL STRESS (St)	Kg/cm <sup>2</sup>	7846

BILL OF MATERIAL FOR SINGLE BELLOW			
SL NO	COMPONENT'S NAME	MATERIAL	QUANTITY
1	BELLOWS	SA240TP304	1No
2	COLLAR	SA240TP304	2 Nos.
3	SLEEVE	SA240TP304	1 No.
4	END PIPE	SA672B70/SA672C70/SA515 Gr.70/SA516Gr.70	2 Nos.
5	HINGE SUPPORT FLANGE #1	SA515Gr.70 /SA516Gr.70/ IS2062Gr.B	1 No.
6	HINGE PIN	CARBON STEEL CLASS8.8	2 Nos.
7	HINGE SUPPORT FLANGE #2	SA515Gr.70 /SA516Gr.70/ IS2062Gr.B	1 No.
8	HINGE MAIN PLATE	SA515Gr.70 /SA516Gr.70/ IS2062Gr.B	2 Nos.
9	HINGE SUPPORT PLATE	SA515Gr.70 /SA516Gr.70/ IS2062Gr.B	4 Nos.
10	SHROUD (COVER)	IS 2062 Gr. A/B	1 No.
11	SHROUD (COVER) SUPPORTS	IS 2062 Gr. A/B	4 Nos.
12	GUSSET	SA515Gr.70 /SA516Gr.70/ IS2062Gr.B	8 Nos.
13	CIRCLIP 2mm THK. (DETAIL NOT SHOWN)	MS	8 Nos.
14	BOLT & NUT-M8	IS 1367 CL6.8/6.0	AR

- NOTES:-**
- BELLOW DESIGN CODE : EJMA LATEST EDITION.
  - WELDING CODE/STD : ASME SEC. IX.
  - BUTT WELD DETAIL : AS PER ASME B16.25 TO SUIT MATCHING PIPE.
  - INSPECTION & TESTING : AS PER APPROVED QP.
  - SURFACE PREPARATION: SP3, POWER TOOL CLEANING.
  - PAINTING DETAILS : TWO COATS (TOTAL DFT 40 MICRON) OF HEAT RESISTANT ALUMINUM PAINT TO IS 13183 Gr.III.
  - SUITABLE SHIPPING BRACKETS WILL BE PROVIDED IN YELLOW COLOUR WHICH MUST BE REMOVED AFTER INSTALLATION.
  - STAINLESS STEEL NAME PLATE WITH REQUIRED DETAILS WILL BE FIXED ON EXPANSION JOINTS.
  - ALL DIMENSION ARE IN MM UNLESS OTHERWISE SPECIFIED.
  - EXPANSION JOINTS WEIGHING MORE THAN 250KGS ARE TO BE PROVIDED WITH LIFTING LUGS.
  - DRAWING IS NOT TO SCALE.
  - THICKNESS OF PRESSURE PARTS INDICATED ARE MINIMUM REQUIREMENTS AND THE SAME SHALL BE AS PER FINITE ELEMENT ANALYSIS.

CUSTOMER: **THDC INDIA LIMITED.**

OWNER'S CONSULTANT: **2X660MW KHURJA STPP (TG PKG)**

MANUFACTURER: **BHARAT HEAVY ELECTRICALS LTD**

JOB NO. **475**  
 STATUS **CONTRACT**  
 DISTRIBUTION

REV.	DATE	DESN	CHD	APPD

TITLE: **HINGED ANGULAR BELLOWS SIZE-1800 NB**

ASSEMBLY WEIGHT : **PE-V0-475-100-M171**

TECH. SPEC.No. PE-TS-475-100-M021 R0

DRAWING NO. **PE-V0-475-100-M171**

SHEET **2** OF **6** REV. **00**

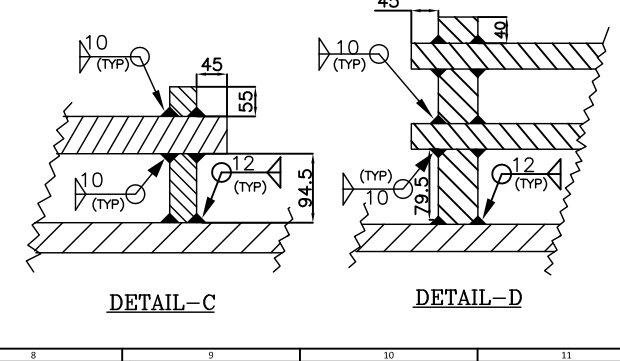
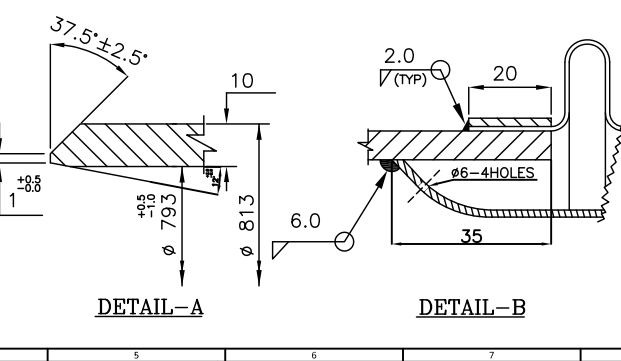
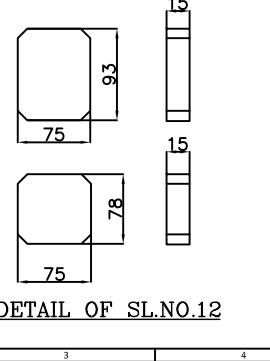
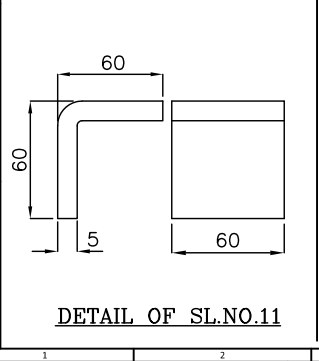
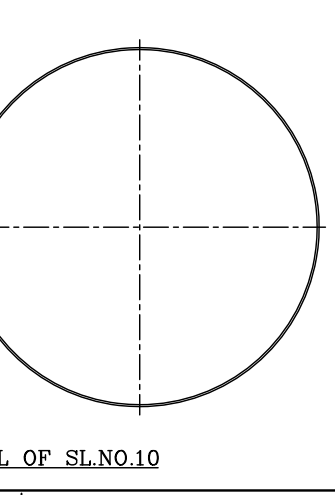
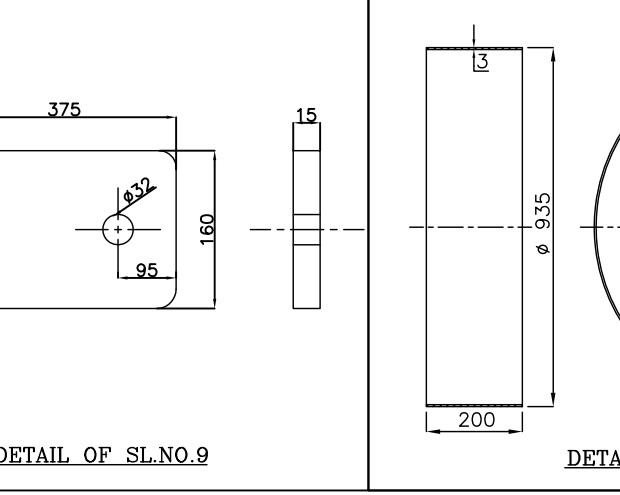
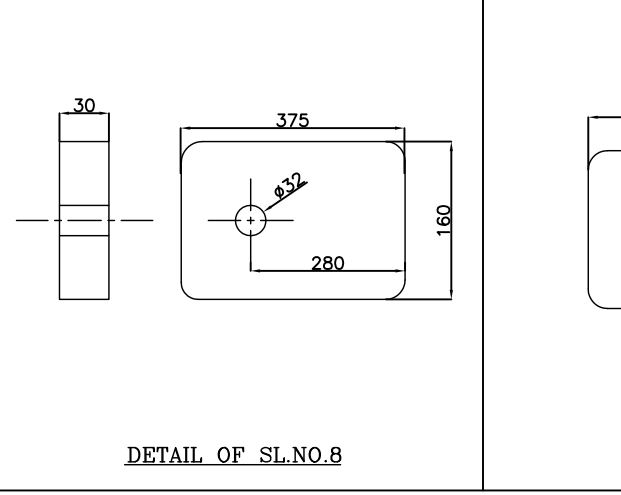
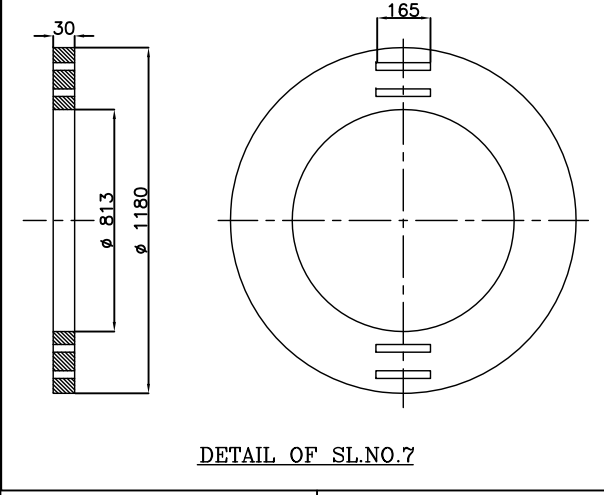
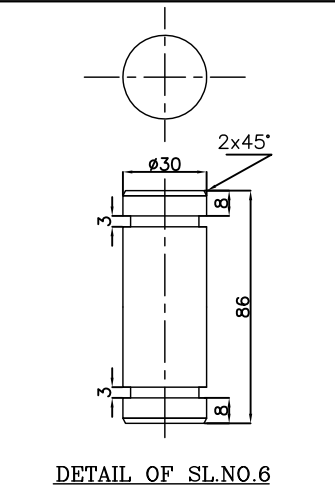
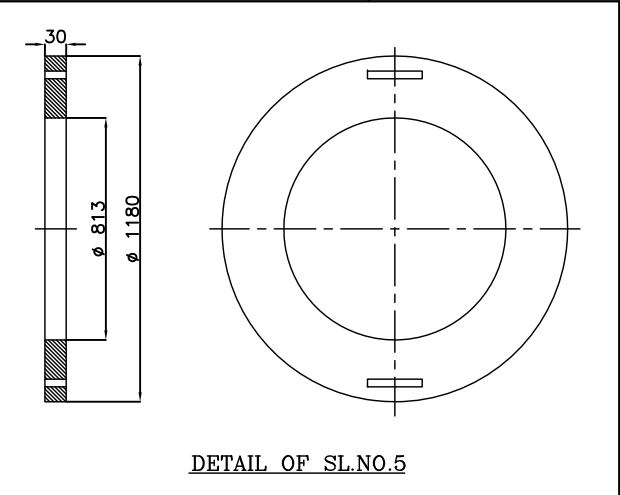
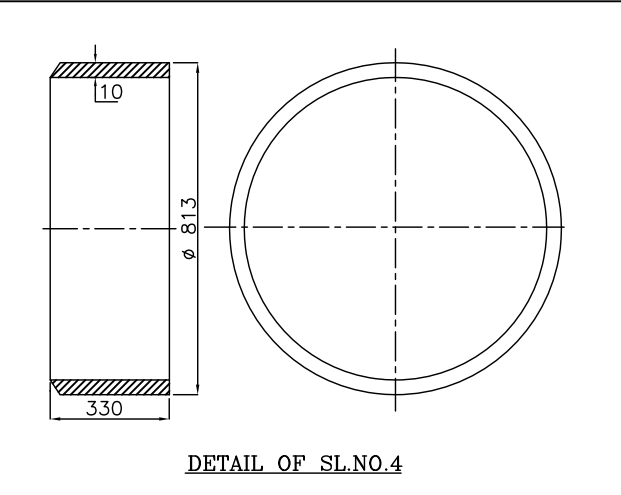
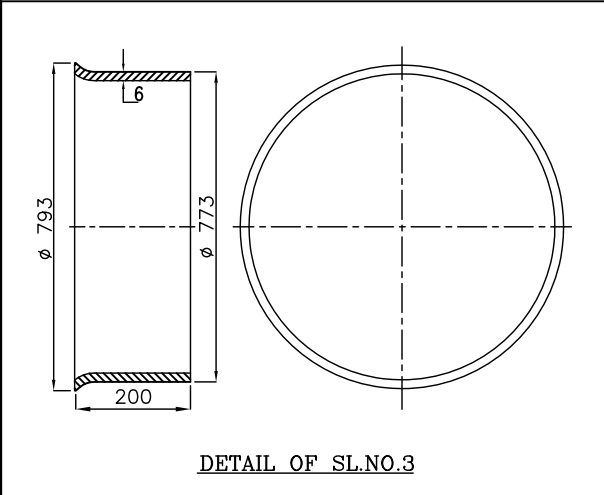
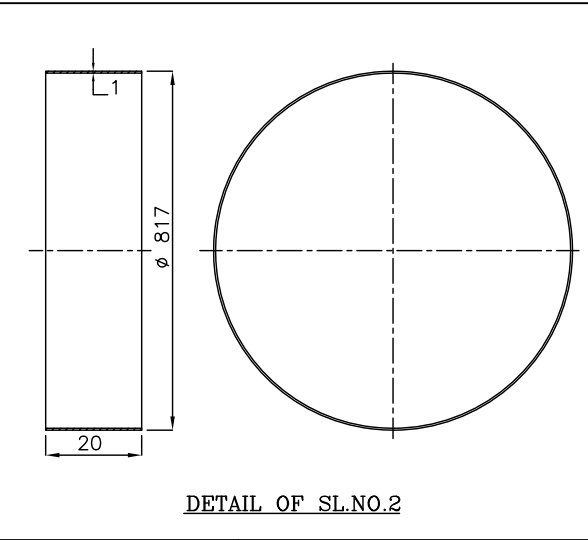
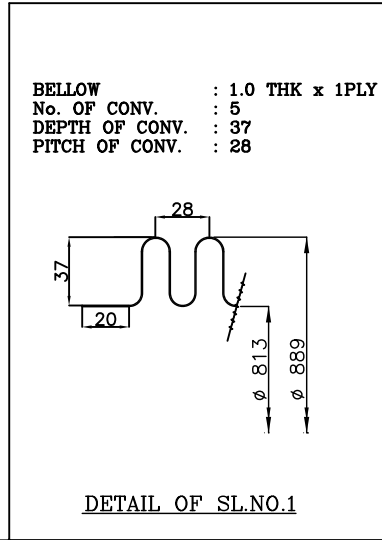
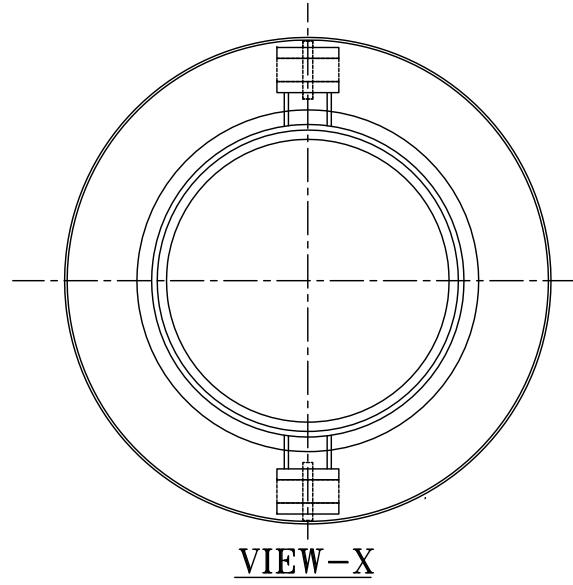
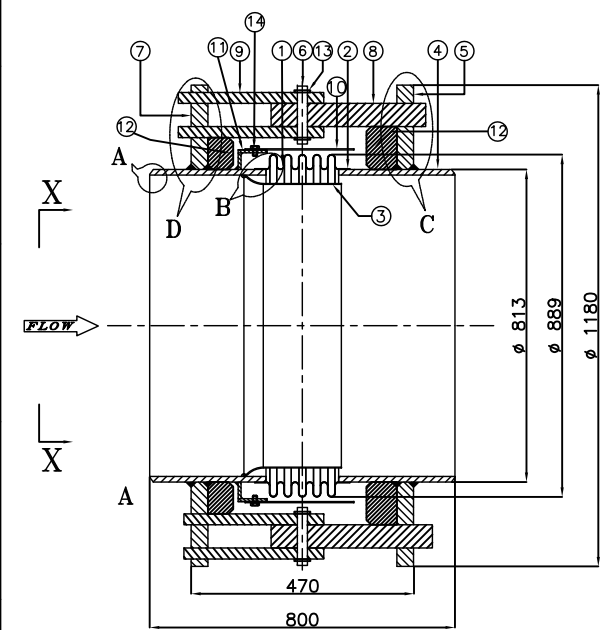

BELLOW DETAILS			
SL NO	DESCRIPTION	UNITS	DATA/PARTICULARS.
1	TAG No.	-	E8 & E10
2	QUANTITIES PER UNIT	Nos.	2
3	TOTAL QUANTITY	Nos.	4
4	LOCATION	-	FLASH TANK-A & B VENT TO COND.
5	FLUID	-	STEAM
6	INSTALLATION	-	HORIZONTAL
7	PIPE SIZE(ODxTHK)	mm	813x10
8	OPERATING PRESSURE	Kg/cm <sup>2</sup> (A)	1.11
9	DESIGN PRESSURE	Kg/cm <sup>2</sup> (G)	1.10
10	HYDRO TEST PRESSURE (FOR 30 Min.)	Kg/cm <sup>2</sup> (G)	1.65
11	VACUUM TEST PRESSURE(FOR 30 Min.)	mm-Hg	50mm of Hg (Abs)
12	OPERATING TEMPERATURE	°C	102
13	DESIGN TEMPERATURE	°C	120
14	BELLOW CYCLE LIFE	Nos.	557322
15	ANGULAR DEFLECTION (DESIGN)	DEGREE	2.5
16	AXIAL SPRING RATE PER CONVOLUTION	Kg/mm	69.58
17	ANGULAR SPRING RATE	Kg-M/Deg.	109.84
18	TOTAL EQUIVALENT MOVEMENT PER BELLOW	mm	18.87
19	OVERALL LENGTH	mm	800
20	BELLOW CONVOLUTED LENGTH	mm	140
21	LIMITING INTERNAL DESIGN PRESSURE BASED ON COLUMN INSTABILITY (Psc)	Kg/cm <sup>2</sup>	47.83
22	LIMITING INTERNAL DESIGN PRESSURE BASED ON INPLANE INSTABILITY (Psi)	Kg/cm <sup>2</sup>	5.91
23	TOTAL STRESS (St)	Kg/cm <sup>2</sup>	6466.38

BILL OF MATERIAL FOR SINGLE BELLOW			
SL NO	COMPONENT'S NAME	MATERIAL	QUANTITY
1	BELLOWS	SA240TP304	1No
2	COLLAR	SA240TP304	2 Nos.
3	SLEEVE	SA240TP304	1 No.
4	END PIPE	SA672B70/SA672C70/SA515GR.70/SA516GR.70	2 Nos.
5	HINGE SUPPORT FLANGE #1	IS 2062 Gr. B/SA 515 / 516 Gr.70	1 No.
6	HINGE PIN	CARBON STEEL CLASS 8.8	2 Nos.
7	HINGE SUPPORT FLANGE #2	IS 2062 Gr. B/SA 515 / 516 Gr.70	1 No.
8	HINGE MAIN PLATE	IS 2062 Gr. B/SA 515 / 516 Gr.70	2 Nos.
9	HINGE SUPPORT PLATE	IS 2062 Gr. B/SA 515 / 516 Gr.70	4 Nos.
10	SHROUD (COVER)	IS 2062 Gr. A/B	1 No.
11	SHROUD (COVER) SUPPORTS	IS 2062 Gr. A/B	4 Nos.
12	GUSSET	IS 2062 Gr. B/SA 515 / 516 Gr.70	4 + 4Nos.
13	CIRCLIP 2mm THK. (DETAIL NOT SHOWN)	SPRING STEEL (EN42J) OR EQUIVALENT	4 Nos.
14	M8 BOLT & NUT	IS 1367 CL 4.6/4.0	AR

- NOTES:-**
- BELLOW DESIGN CODE : EJMA LATEST EDITION.
  - WELDING CODE/STD : ASME SEC IX.
  - BUTT WELD DETAIL : AS PER ASME B16.25 TO SUIT MATCHING PIPE.
  - INSPECTION & TESTING : AS PER APPROVED QP.
  - SURFACE PREPARATION: SP3, POWER TOOL CLEANING.
  - PAINTING DETAILS : TWO COATS (TOTAL DFT 40 MICRON) OF HEAT RESISTANT ALUMINUM PAINT TO IS 13163 Gr.III.
  - SUITABLE SHIPPING BRACKETS WILL BE PROVIDED IN YELLOW COLOUR WHICH MUST BE REMOVED AFTER INSTALLATION.
  - STAINLESS STEEL NAME PLATE WITH REQUIRED DETAILS WILL BE FIXED ON EXPANSION JOINTS.
  - ALL DIMENSION ARE IN MM UNLESS OTHERWISE SPECIFIED.
  - EXPANSION JOINTS WEIGHING MORE THAN 250KGS ARE TO BE PROVIDED WITH LIFTING LUGS.
  - DRAWING IS NOT TO SCALE.
  - THICKNESS OF PRESSURE PARTS INDICATED ARE MINIMUM REQUIREMENTS AND THE SAME SHALL BE AS PER FINITE ELEMENT ANALYSIS.

**CUSTOMER:** THDC INDIA LIMITED.

**OWNER'S CONSULTANT:** 2X660MW KHURJA STPP (TG PKG)

**MANUFACTURER:** BHARAT HEAVY ELECTRICALS LTD  
 POWER SECTOR  
 PROJECT ENGINEERING MANAGEMENT  
 NOIDA

**JOB NO. 475**  
**STATUS CONTRACT**  
**DISTRIBUTION**

REV.	DATE	DESN	CHD	APPD

**TITLE** HINGED ANGULAR BELLOWS  
**SIZE-800 NB**

**ASSEMBLY WEIGHT :**      **DEPT. MPL**      **DRAWING NO. PE-V0-475-100-M171**  
**TECH. SPEC.No.:** PE-TS-475-100-M021 R0      **SIGN**      **SHEET 3 OF 6**      **REV.00**

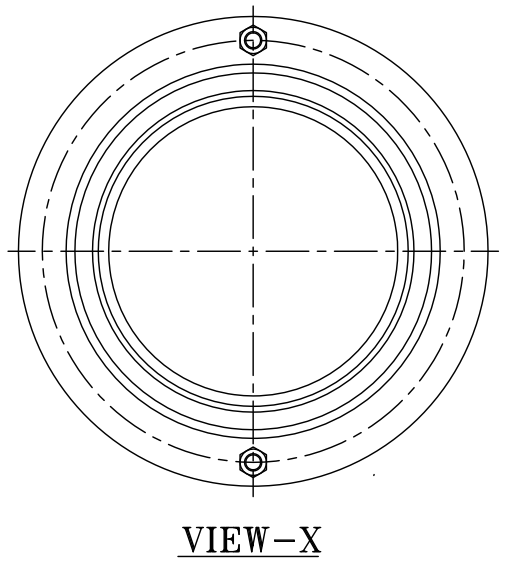
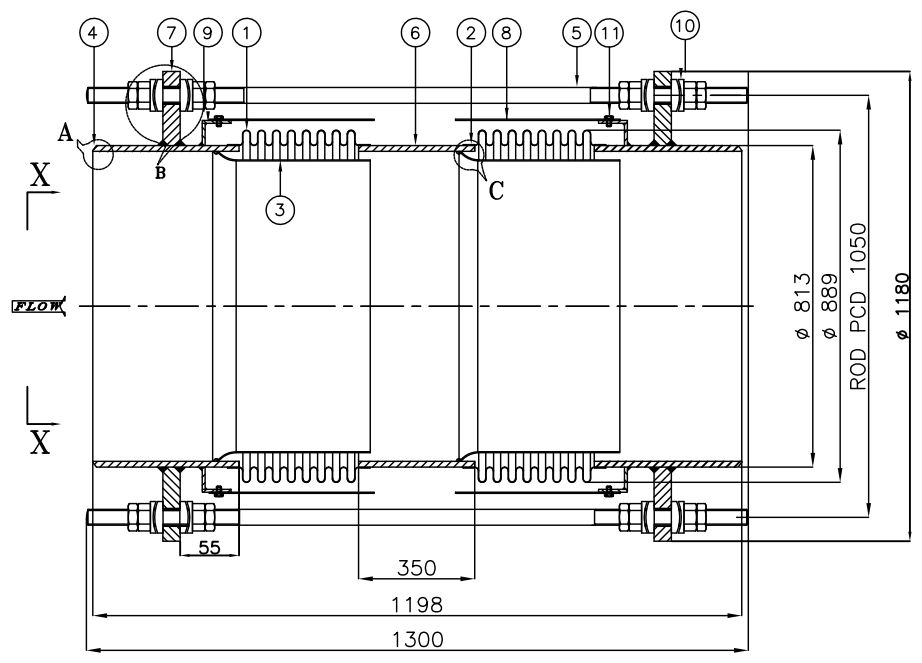

BELLOW DETAILS			
SL NO	DESCRIPTION	UNITS	DATA/PARTICULARS.
1	TAG No.	-	E7 & E9
2	QUANTITIES PER UNIT	Nos.	2
3	TOTAL QUANTITY	Nos.	4
4	LOCATION	-	FLASH TANK-A & B VENT TO COND.
5	FLUID	-	STEAM
6	INSTALLATION	-	VERTICAL
7	PIPE SIZE(ODxTHK)	mm	813 x 10
8	OPERATING PRESSURE	Kg/cm <sup>2</sup> (A)	1.11
9	DESIGN PRESSURE	Kg/cm <sup>2</sup> (G)	1.1
10	HYDRO TEST PRESSURE (FOR 30 Min.)	Kg/cm <sup>2</sup> (G)	1.65
11	VACUUM TEST PRESSURE(FOR 30 Min.)	mm-Hg	50mm of Hg
12	OPERATING TEMPERATURE	°C	102
13	DESIGN TEMPERATURE	°C	120
14	BELLOW CYCLE LIFE	Nos.	682782
15	LATERAL DEFLECTION (DESIGN)	mm	30
16	AXIAL SPRING RATE PER CONVOLUTION	Kg/mm	21.74
17	LATERAL SPRING RATE	Kg/mm	22.74
18	ANGULAR SPRING RATE AT EACH END	Kg-M/Deg.	47.74
19	ANGULAR SPRING RATE FOR FULL ASSEMBLY	Kg-M/Deg.	95.47
20	TOTAL EQUIVALENT MOVEMENT (FOR ASSEMBLY)	mm	58.84
21	TOTAL EQUIVALENT MOVEMENT (PER BELLOW)	mm	29.42
22	OVERALL LENGTH	mm	1198
23	BELLOW CENTER DISTANCE	mm	574
24	BELLOW CONVOLUTED LENGTH	mm	224
25	LIMITING INTERNAL DESIGN PRESSURE BASED ON COLUMN INSTABILITY (P <sub>sc</sub> )	Kg/cm <sup>2</sup>	5.18
26	LIMITING INTERNAL DESIGN PRESSURE BASED ON INPLANE INSTABILITY (P <sub>si</sub> )	Kg/cm <sup>2</sup>	5.91
27	TOTAL STRESS (St)	Kg/cm <sup>2</sup>	6311.62

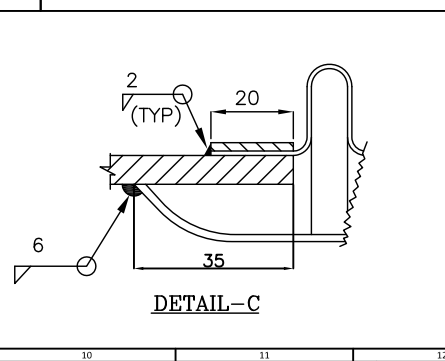
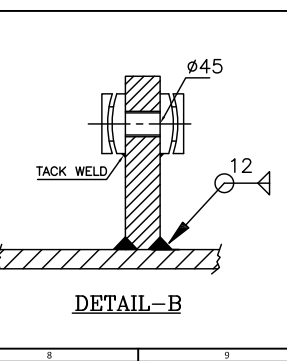
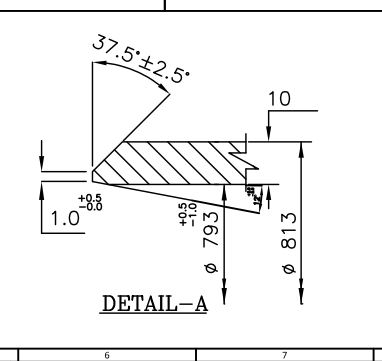
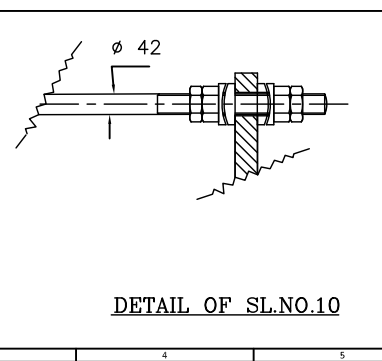
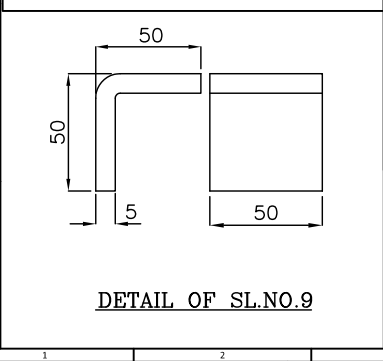
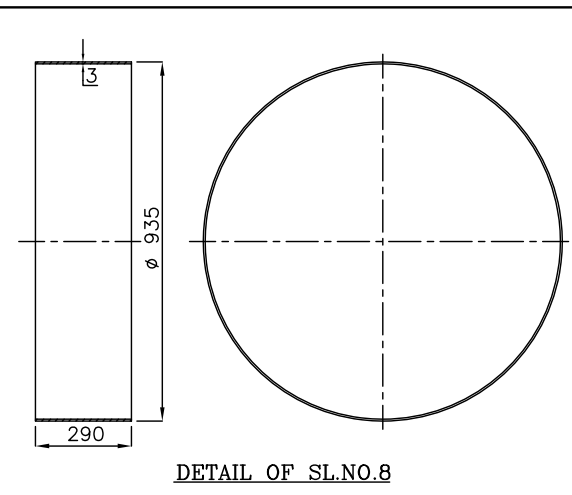
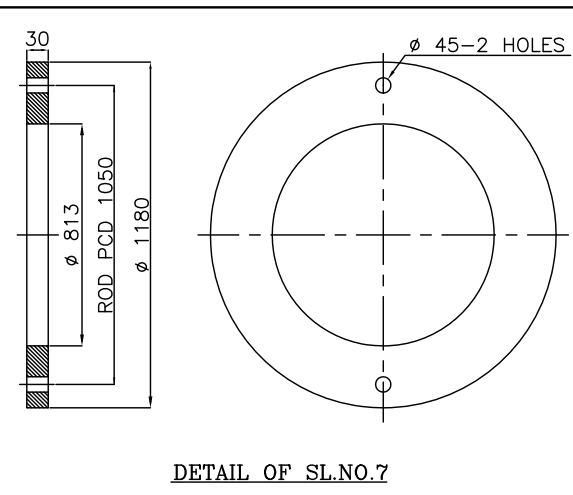
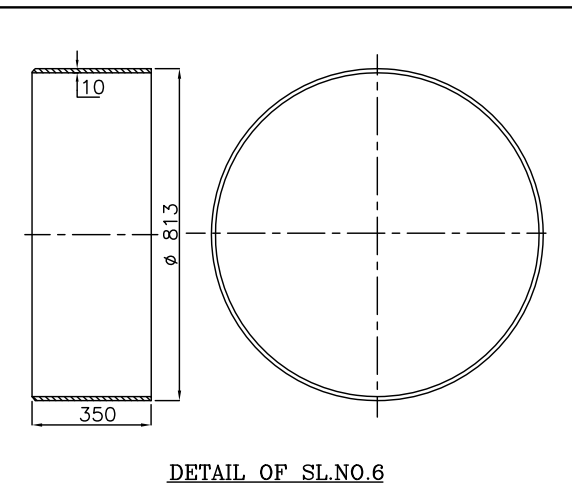
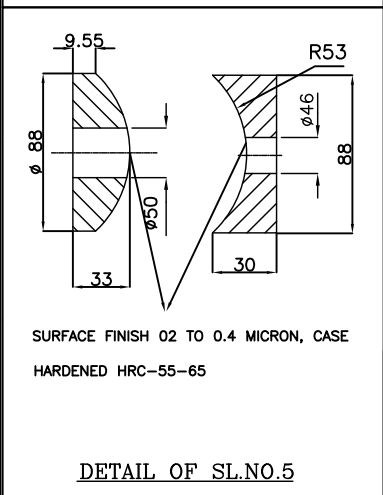
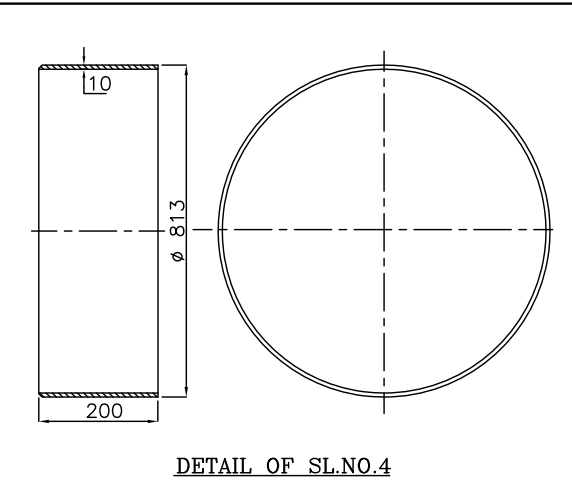
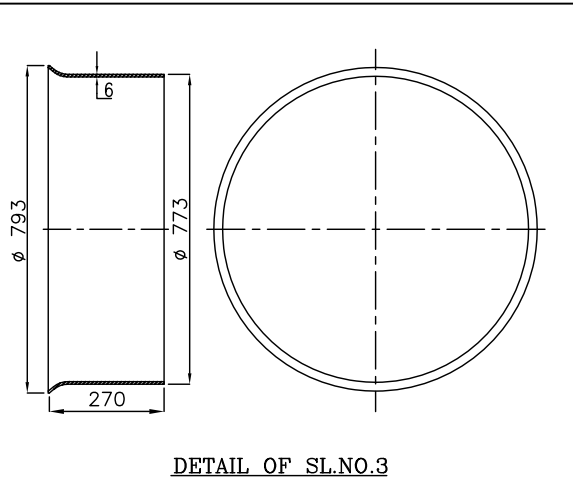
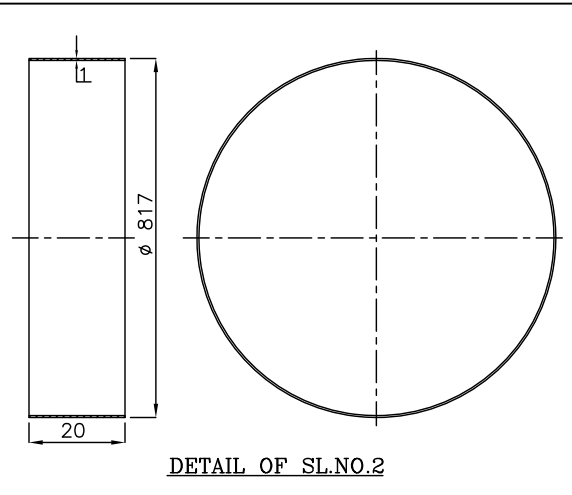
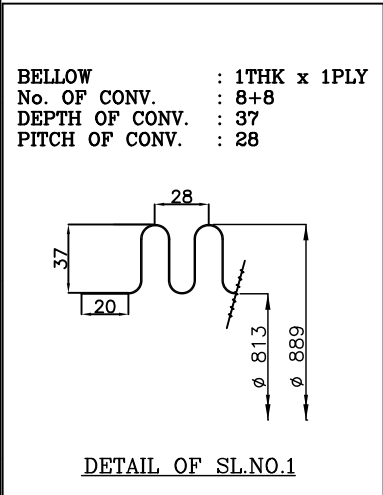

BILL OF MATERIAL FOR SINGLE BELLOW			
SL NO	COMPONENT'S NAME	MATERIAL	QUANTITY
1	BELLOWS	SA240TP304	2 Nos.
2	COLLAR	SA240TP304	4 Nos.
3	SLEEVE	SA240TP304	2 Nos.
4	END PIPE	SA672B70/SA672C70/SA515GR.70/SA516GR.70	2 Nos.
5	SPHERICAL WASHER	SA515GR.60	8 Nos.
6	SPOOL PIPE	SA672B70/SA672C70/SA515GR.70/SA516GR.70	1 No.
7	ROUND FLANGE	IS 2062 Gr. B/SA 515 / 516 Gr.70	2 Nos.
8	SHROUD (COVER)	IS 2062 Gr. A/B	2 Nos.
9	SHROUD (COVER) SUPPORTS	IS 2062 Gr. A/B	8 Nos.
10	LIMIT ROD WITH NUTS	IS 1367 (CL. 6.8 & 6.0)	2 Nos.
11	M8 BOLT & NUT	IS 1367 CL4.6/4.0	AR

- NOTES:-**
- BELLOW DESIGN CODE : EJMA LATEST EDITION.
  - WELDING CODE/STD : ASME SEC IX.
  - BUTT WELD DETAIL : AS PER ASME B16.25 TO SUIT MATCHING PIPE.
  - INSPECTION & TESTING : AS PER APPROVED QP.
  - SURFACE PREPARATION: SP3, POWER TOOL CLEANING.
  - PAINTING DETAILS : TWO COATS (TOTAL DFT 40 MICRON) OF HEAT RESISTANT ALUMINUM PAINT TO IS 13183 Gr.III.
  - SUITABLE SHIPPING BRACKETS WILL BE PROVIDED IN YELLOW COLOUR WHICH MUST BE REMOVED AFTER INSTALLATION.
  - STAINLESS STEEL NAME PLATE WITH REQUIRED DETAILS WILL BE FIXED ON EXPANSION JOINTS.
  - ALL DIMENSION ARE IN MM UNLESS OTHERWISE SPECIFIED.
  - EXPANSION JOINTS WEIGHING MORE THAN 250KGS ARE TO BE PROVIDED WITH LIFTING LUGS.
  - DRAWING IS NOT TO SCALE.
  - THICKNESS OF PRESSURE PARTS INDICATED ARE MINIMUM REQUIREMENTS AND THE SAME SHALL BE AS PER FINITE ELEMENT ANALYSIS.

CUSTOMER: **THDC INDIA LIMITED.**

OWNER'S CONSULTANT: **2X660MW KHURJA STPP (TG PKG)**

MANUFACTURER: **BHARAT HEAVY ELECTRICALS LTD**  
POWER SECTOR  
PROJECT ENGINEERING MANAGEMENT  
NOIDA

REV.	DATE	DESN	CHD	APPD

TITLE: **TIED LATERAL ANGULAR BELLOWS**  
**SIZE-800 NB**

ASSEMBLY WEIGHT : \_\_\_\_\_ DEPT. MPL \_\_\_\_\_ DRAWING NO. **PE-V0-475-100-M171**

TECH. SPEC.No.: PE-TS-475-100-M021 RO SIGN \_\_\_\_\_ SHEET 4 OF 6 REV.00

JOB NO.	475
STATUS	CONTRACT
DISTRIBUTION	

THE INFORMATION ON THIS DOCUMENT IS THE PROPERTY OF BHARAT HEAVY ELECTRICALS LIMITED. IT IS TO BE USED ONLY FOR THE PROJECT AND NOT TO BE REPRODUCED OR TRANSMITTED IN ANY FORM OR BY ANY MEANS, ELECTRONIC OR MECHANICAL, WITHOUT THE WRITTEN PERMISSION OF BHARAT HEAVY ELECTRICALS LIMITED.

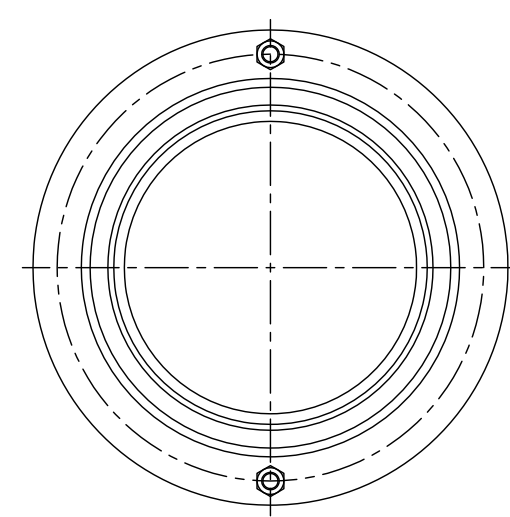
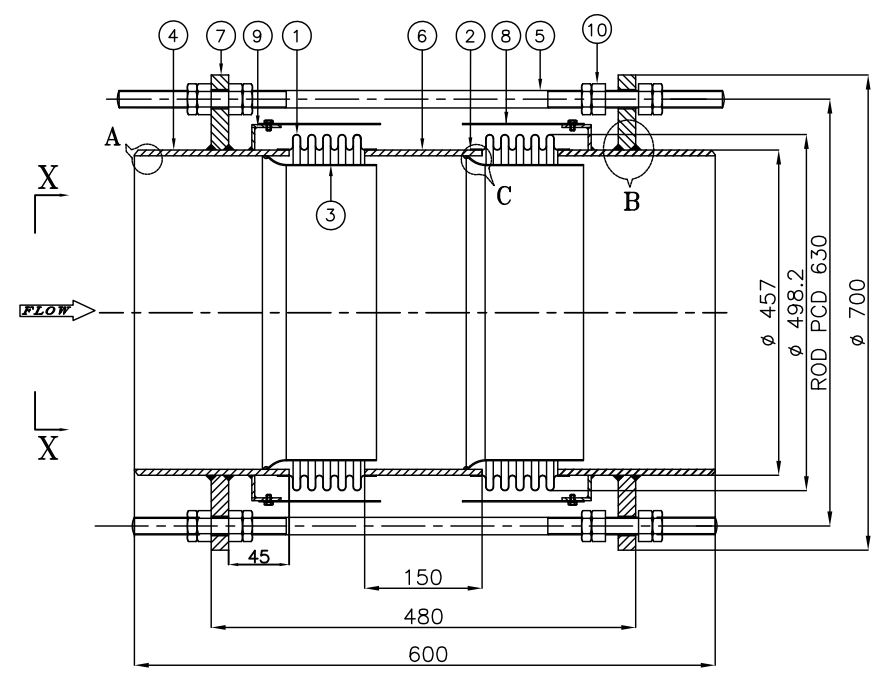

VIEW X-X

BELLOW DETAILS			
SL NO	DESCRIPTION	UNITS	DATA/PARTICULARS
1	TAG No.	-	E11, E12 & E13
2	QUANTITIES PER SET	Nos.	3
3	TOTAL QUANTITY	Nos.	6
4	LOCATION	-	CEP A, B, C SUCTION
5	FLUID	-	CONDENSATE
6	INSTALLATION	-	HORIZONTAL
7	PIPE SIZE(ODxTHK)	mm	457 x 9.53
8	OPERATING PRESSURE	Kg/cm <sup>2</sup> (A)	0.12
9	DESIGN PRESSURE	Kg/cm <sup>2</sup> (G)	2.0
10	HYDRO TEST PRESSURE (FOR 30 Min.)	Kg/cm <sup>2</sup> (G)	3.0
11	VACUUM TEST PRESSURE(FOR 30 Min.)	mm-Hg	50mm of Hg (Abs)
12	OPERATING TEMPERATURE	°C	46.1
13	DESIGN TEMPERATURE	°C	60
14	BELLOW CYCLE LIFE	Nos.	26585
15	AXIAL COMPRESSION (DESIGN)	mm	15
16	LATERAL DEFLECTION (DESIGN)	mm	7
17	AXIAL SPRING RATE PER CONVOLUTION	Kg/mm	25.38
18	LATERAL SPRING RATE	Kg/mm	47.36
19	ANGULAR SPRING RATE	Kg-M/Deg.	NA
20	TOTAL EQUIVALENT MOVEMENT (FOR ASSEMBLY)	mm	33.32
21	TOTAL EQUIVALENT MOVEMENT (PER BELLOW)	mm	16.66
22	OVERALL LENGTH	mm	600
23	BELLOW CENTER DISTANCE	mm	250
24	BELLOW CONVOLUTED LENGTH	mm	100
25	LIMITING INTERNAL DESIGN PRESSURE BASED ON COLUMN INSTABILITY (Psc)	Kg/cm <sup>2</sup>	13.56
26	LIMITING INTERNAL DESIGN PRESSURE BASED ON INPLANE INSTABILITY (Psi)	Kg/cm <sup>2</sup>	8.07
27	TOTAL STRESS (St)	Kg/cm <sup>2</sup>	10330

BILL OF MATERIAL FOR SINGLE BELLOW			
SL NO	COMPONENT'S NAME	MATERIAL	QUANTITY
1	BELLOWS	SA240TP304	2 Nos.
2	COLLAR	SA240TP304	4 Nos.
3	SLEEVE	SA240TP304	2 Nos.
4	END PIPE	SA106Gr.B	2 Nos.
5	LIMIT ROD WITH NUTS	CS (CL. 6.8 & 6.0)	2 Nos.
6	SPOOL PIPE	SA106Gr.B	1 No.
7	ROUND FLANGE	IS 2062 Gr. B/SA 515 / 516 Gr.70	2 Nos.
8	SHROUD (COVER)	IS 2062 Gr. B	2 Nos.
9	SHROUD (COVER) SUPPORTS	IS 2062 Gr. B	8 Nos.
10	NUT, LOCKNUT & WASHER	IS 1367 CL6.8/6.0	AR

- NOTES:-
- BELLOW DESIGN CODE : EJMA LATEST EDITION.
  - WELDING CODE/STD : ASME SEC IX.
  - BUTT WELD DETAIL : AS PER ASME B16.25 TO SUIT MATCHING PIPE.
  - INSPECTION & TESTING : AS PER APPROVED QP.
  - SURFACE PREPARATION: SP3, POWER TOOL CLEANING
  - PAINTING DETAILS : BELLOWS FIRST SHALL BE PAINTED WITH TWO COATS OF RED OXIDE ZINC PHOSPHATE PRIMER (ALKYD BASE) WITH EACH COAT OF DFT EQUAL TO 25 MICRONS CONFORMING TO IS 12744. FINISH PAINT SHALL BE THREE COATS (DFT 35 MICRONS EACH COAT) OF SYNTHETIC ENAMEL PAINT (LONG OIL ALKYD) AS PER IS: 2932. TOTAL DFT OF PRIMER AND PAINT SHALL BE 155 MICRONS. (COLOUR SHADE-SEA GREEN SHADE NO. ISC-217).
  - SUITABLE SHIPPING BRACKETS WILL BE PROVIDED IN YELLOW COLOUR WHICH MUST BE REMOVED AFTER INSTALLATION.
  - STAINLESS STEEL NAME PLATE WITH REQUIRED DETAILS WILL BE FIXED ON EXPANSION JOINTS.
  - ALL DIMENSION ARE IN MM UNLESS OTHERWISE SPECIFIED.
  - EXPANSION JOINTS WEIGHING MORE THAN 250KGS ARE TO BE PROVIDED WITH LIFTING LUGS.
  - DRAWING IS NOT TO SCALE.
  - THICKNESS OF PRESSURE PARTS INDICATED ARE MINIMUM REQUIREMENTS AND THE SAME SHALL BE AS PER FINITE ELEMENT ANALYSIS.

CUSTOMER: **THDC INDIA LIMITED.**

OWNER'S CONSULTANT: **2X660MW KHURJA STPP (TG PKG)**

MANUFACTURER: **BHARAT HEAVY ELECTRICALS LTD**  
POWER SECTOR  
PROJECT ENGINEERING MANAGEMENT  
NOIDA

TITLE: **UNTIED BELLOWS  
SIZE-450 NB**

ASSEMBLY WEIGHT: **PE-V0-475-100-M171**

TECH. SPEC.No.: **PE-TS-475-100-M021 R0**

DRAWING NO. **PE-V0-475-100-M171**  
SHEET **5** OF **6** REV. **00**

BELLOW : 0.6THK x 1PLY.  
No. OF CONV. : 5+5  
DEPTH OF CONV. : 20  
PITCH OF CONV. : 20

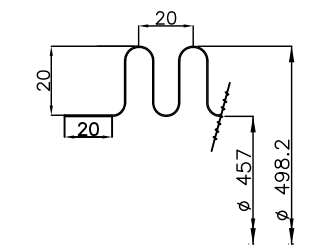

DETAIL OF SL.NO.1

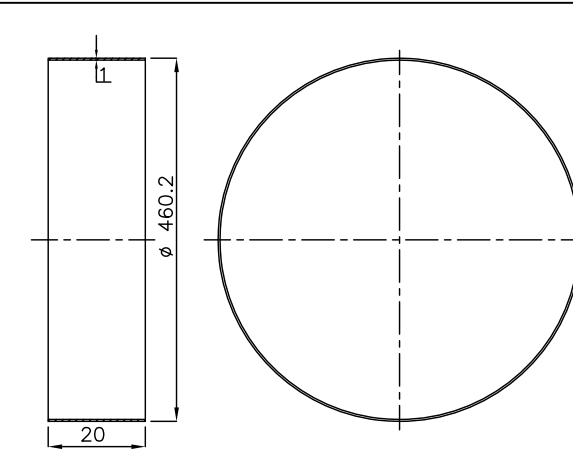

DETAIL OF SL.NO.2

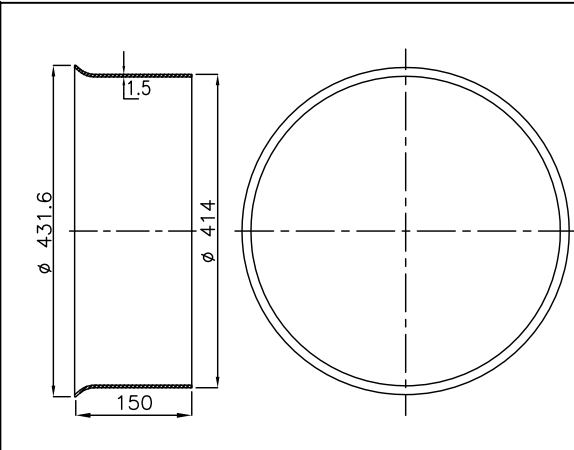

DETAIL OF SL.NO.3

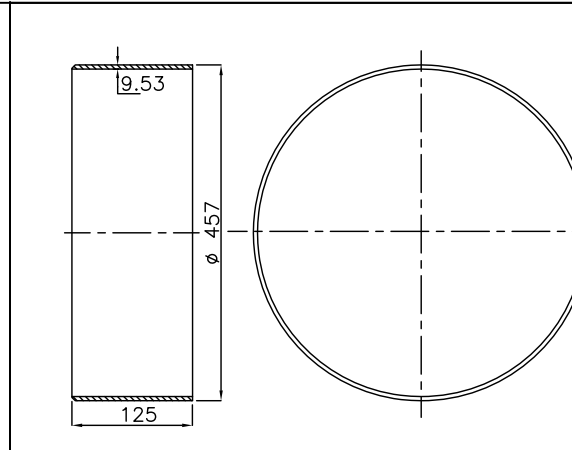

DETAIL OF SL.NO.4

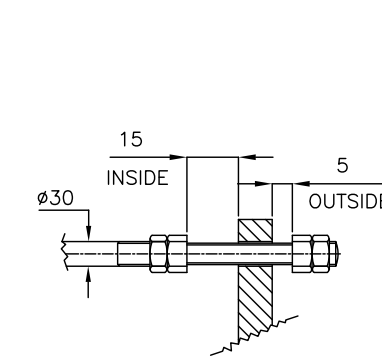

DETAIL OF SL.NO.5

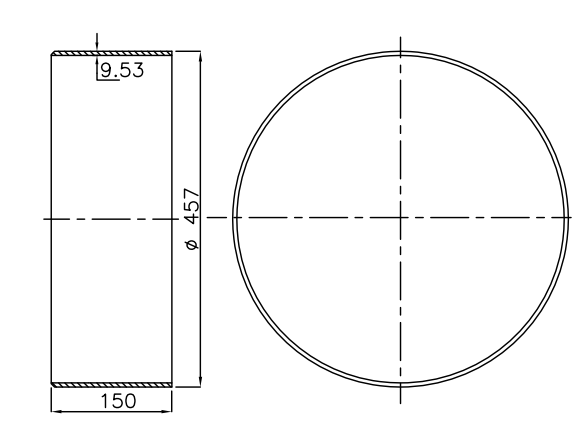

DETAIL OF SL.NO.6

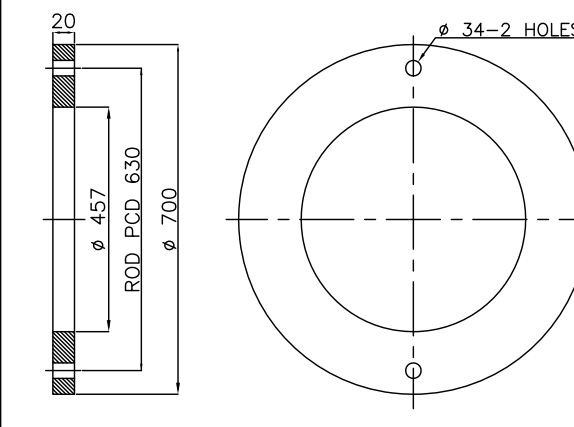

DETAIL OF SL.NO.7

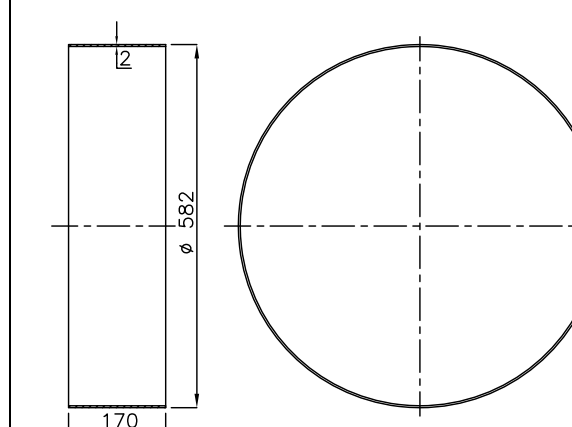

DETAIL OF SL.NO.8

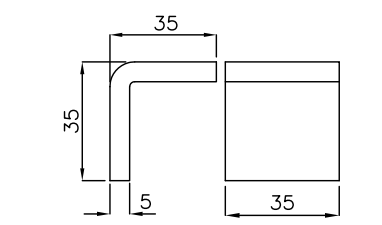

DETAIL OF SL.NO.9

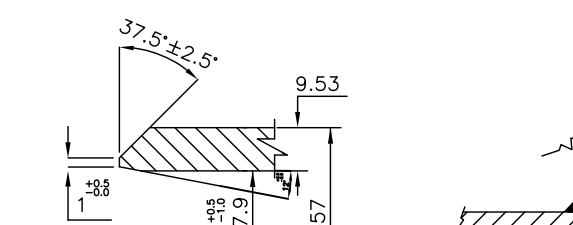

DETAIL-A

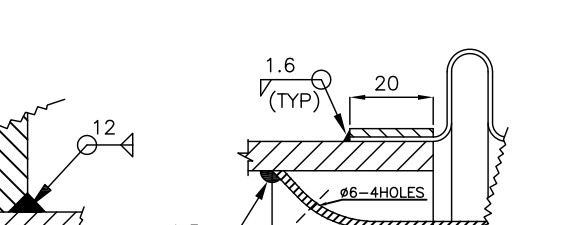

DETAIL-B

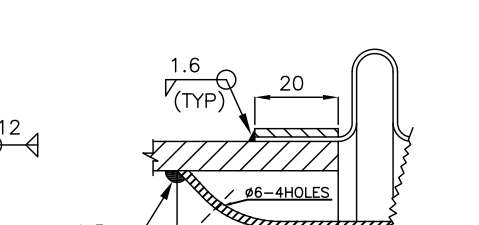

DETAIL-C

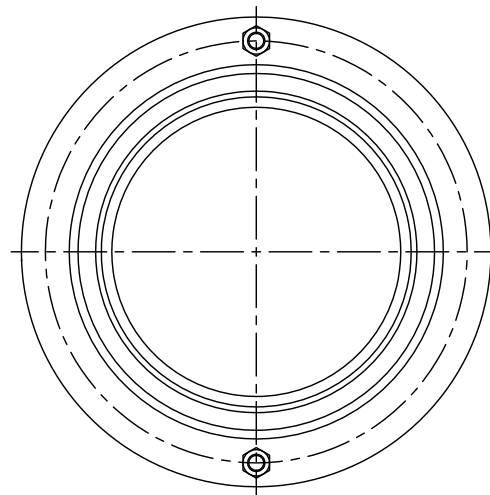
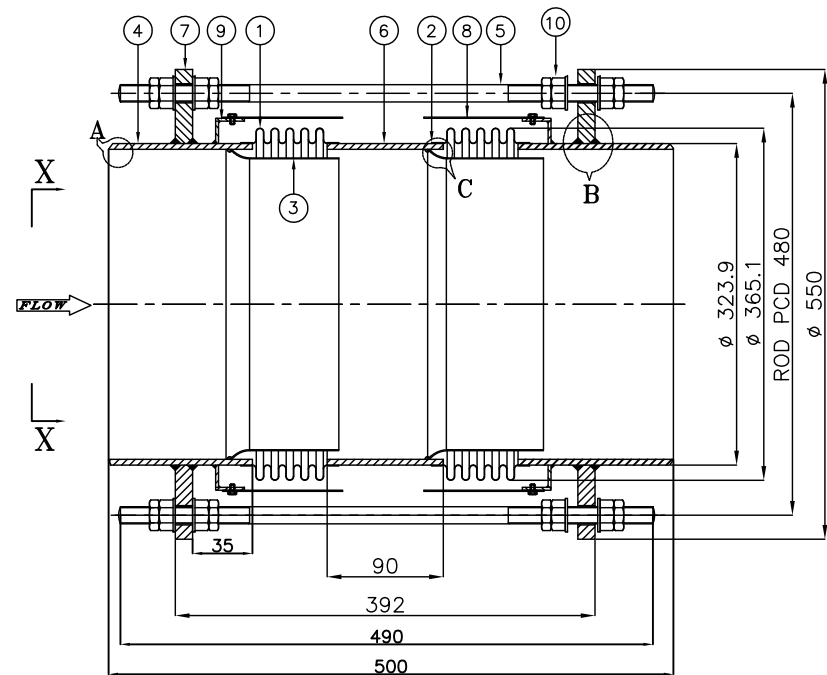

VIEW X-X

BELLOW DETAILS			
SL NO	DESCRIPTION	UNITS	DATA/PARTICULARS.
1	TAG No.	-	E14, E15, E16 & E17
2	QUANTITIES PER SET	Nos.	4
3	TOTAL QUANTITY	Nos.	8
4	LOCATION	-	MAIN CONDENSATE SUCTION
5	FLUID	-	CONDENSATE
6	INSTALLATION	-	VERTICAL
7	PIPE SIZE(ODxTHK)	mm	323.9 x 6.35
8	OPERATING PRESSURE	Kg/cm <sup>2</sup> (A)	0.12
9	DESIGN PRESSURE	Kg/cm <sup>2</sup> (G)	2.0
10	HYDRO TEST PRESSURE (FOR 30 Min.)	Kg/cm <sup>2</sup> (G)	3.0
11	VACUUM TEST PRESSURE(FOR 30 Min.)	mm-Hg	50mm of Hg (Abs)
12	OPERATING TEMPERATURE	°C	46.1
13	DESIGN TEMPERATURE	°C	60
14	BELLOW CYCLE LIFE	Nos.	22844
15	AXIAL COMPRESSION (DESIGN)	mm	17
16	LATERAL DEFLECTION (DESIGN)	mm	7
17	AXIAL SPRING RATE	Kg/mm	18.49
18	LATERAL SPRING RATE	Kg/mm	30.95
19	ANGULAR SPRING RATE	Kg-M/Deg.	NA
20	TOTAL EQUIVALENT MOVEMENT (FOR ASSEMBLY)	mm	35.56
21	TOTAL EQUIVALENT MOVEMENT (PER BELLOW)	mm	17.78
22	OVERALL LENGTH	mm	500
23	BELLOW CENTER DISTANCE	mm	190
24	BELLOW CONVOLUTED LENGTH	mm	100
25	LIMITING INTERNAL DESIGN PRESSURE BASED ON COLUMN INSTABILITY (Psc)	Kg/cm <sup>2</sup>	9.88
26	LIMITING INTERNAL DESIGN PRESSURE BASED ON INPLANE INSTABILITY (Psi)	Kg/cm <sup>2</sup>	9.29
27	TOTAL STRESS (St)	Kg/cm <sup>2</sup>	10628.15

BILL OF MATERIAL FOR SINGLE BELLOW			
SL NO	COMPONENT'S NAME	MATERIAL	QUANTITY
1	BELLOWS	SA240TP304	2 Nos.
2	COLLAR	SA240TP304	4 Nos.
3	SLEEVE	SA240TP304	2 Nos.
4	END PIPE	SA106Gr.B	2 Nos.
5	LIMIT ROD	IS 1367 CL 6.8	2 Nos.
6	SPOOL PIPE	SA106Gr.B	1 No.
7	ROUND FLANGE	IS 2062 Gr. B/SA 515 / 516 Gr.70	2 Nos.
8	SHROUD (COVER)	IS 2062 Gr. B	2 Nos.
9	SHROUD (COVER) SUPPORTS	IS 2062 Gr. B	8 Nos.
10	BOLT & NUT-M8	IS 1367 CL6.8/6.0	AR
11	NUT, LOCKNUT & WASHER (size M25)	IS 1367 CL6.8/6.0	AR

- NOTES:-
- BELLOW DESIGN CODE : EJMA LATEST EDITION.
  - WELDING CODE/STD : ASME SEC IX.
  - BUTT WELD DETAIL : AS PER ASME B16.25 TO SUIT MATCHING PIPE.
  - INSPECTION & TESTING : AS PER APPROVED OP.
  - SURFACE PREPARATION: SP3, POWER TOOL CLEANING
  - PAINTING DETAILS : BELLOWS FIRST SHALL BE PAINTED WITH TWO COATS OF RED OXIDE ZINC PHOSPHATE PRIMER (ALKYD BASE) WITH EACH COAT OF DFT EQUAL TO 25 MICRONS CONFORMING TO IS 12744. FINISH PAINT SHALL BE THREE COATS (DFT 35 MICRONS EACH COAT) OF SYNTHETIC ENAMEL PAINT (LONG OIL ALKYD) AS PER IS: 2932. TOTAL DFT OF PRIMER AND PAINT SHALL BE 155 MICRONS. (COLOUR SHADE-SEA GREEN SHADE NO. ISC-217).
  - SUITABLE SHIPPING BRACKETS WILL BE PROVIDED IN YELLOW COLOUR WHICH MUST BE REMOVED AFTER INSTALLATION.
  - STAINLESS STEEL NAME PLATE WITH REQUIRED DETAILS WILL BE FIXED ON EXPANSION JOINTS.
  - ALL DIMENSION ARE IN MM UNLESS OTHERWISE SPECIFIED.
  - EXPANSION JOINTS WEIGHING MORE THAN 250KGS ARE TO BE PROVIDED WITH LIFTING LUGS.
  - DRAWING IS NOT TO SCALE.
  - THICKNESS OF PRESSURE PARTS INDICATED ARE MINIMUM REQUIREMENTS AND THE SAME SHALL BE AS PER FINITE ELEMENT ANALYSIS.

BELLOW : 0.6THK x 1PLY  
 No. OF CONV. : 5+5  
 DEPTH OF CONV. : 20  
 PITCH OF CONV. : 20

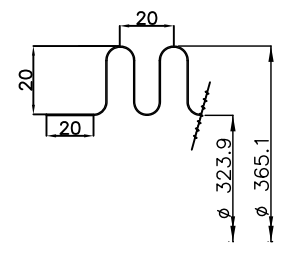

DETAIL OF SL.NO.1

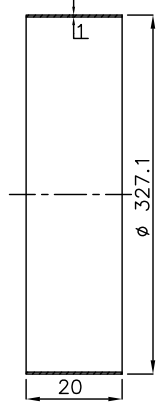

DETAIL OF SL.NO.2

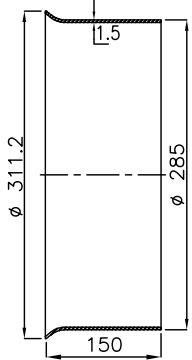

DETAIL OF SL.NO.3

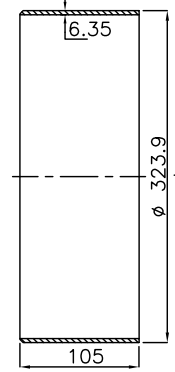

DETAIL OF SL.NO.4

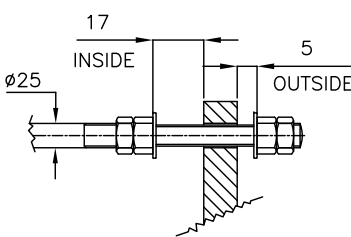

DETAIL OF SL.NO.5

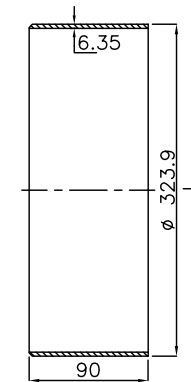

DETAIL OF SL.NO.6

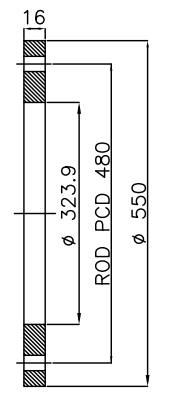

DETAIL OF SL.NO.7

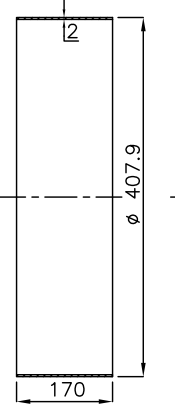

DETAIL OF SL.NO.8

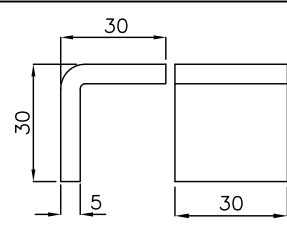

DETAIL OF SL.NO.9

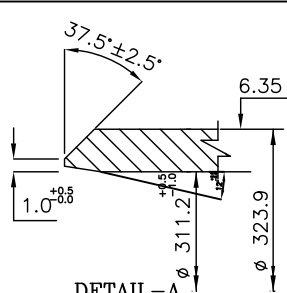

DETAIL-A

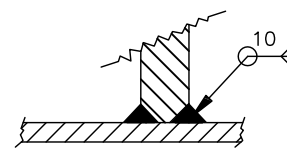

DETAIL-B

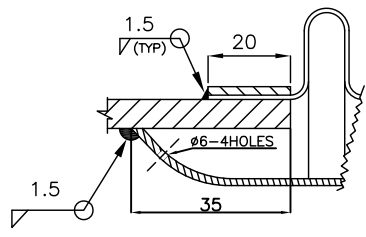

DETAIL-C

CUSTOMER: THDC INDIA LIMITED.

OWNER'S CONSULTANT: 2X660MW KHURJA STPP (TG PKG)

MANUFACTURER: BHARAT HEAVY ELECTRICALS LTD  
 POWER SECTOR  
 PROJECT ENGINEERING MANAGEMENT  
 NOIDA

TITLE: UNTIED BELLOWS  
 SIZE-300 NB

ASSEMBLY WEIGHT : DEPT. MPL  
 SIGN. SIGN. DRAWING NO. PE-V0-475-100-M171  
 TECH. SPEC.No.: PE-TS-475-100-M021 R0 SHEET 6 OF 6 REV.00

JOB NO.	475			
STATUS	CONTRACT			
DISTRIBUTION				
REV.	DATE	DESN	CHD	APPD

501929/2021/PS-PEM-MPL



## PRE - QUALIFYING REQUIREMENTS

DOCUMENT NO: PE-TS-475-000-M052

REVISION NO: 00, DATE: 11.10.2021

SHEET: 1 of 2

Standard document No.:PE-TS-999-000-M052

**Project: 2X660MW KHURJA STPP (TG PKG)****Package: METAL EXPANSION BELLOWS****CRITERIA FOR EVALUATION (TECHNICAL):**1. Technical Pre-Qualifying Requirements:

1.1 The bidder should have designed, in-house manufactured, tested, inspected and supplied metal expansion bellows (Gimbal / Hinged) with minimum size of 1600 NB (Min. Design pressure: 1.1 Kg/cm<sup>2</sup>(g), Min Design temperature: 50°C), for use in power cycle piping of power plant or for similar application in other industries.

1.2 The item(s) mentioned in point 1.1 should have performed successfully for atleast one year. To establish meeting this requirement, the bidder shall conform to any one of the following clauses:

- (i) Execution of two purchase orders for different End-users with the item(s) performing successfully for one (1) year from date of commissioning to the date of bid submission as defined in Notice Inviting Tender (NIT) by BHEL-PEM. Different projects of a customer shall be considered as different End-users.
- (ii) Minimum one (1) repeat contract from two (2) different Purchasers (i.e. 2 Nos of Purchase orders from each purchaser). A contract shall be considered as repeat, when the second contract is given by the same purchaser after lapse of minimum one (1) year from supply completion of first contract.
- (iii) Execution of one (1) purchase order as per sl. no. (i) above from one End-user and one (1) repeat contract from another Purchaser as per sl. No. (ii) above.
- (iv) Three (3) repeat contracts from one (1) Purchaser. Second and third repeat contract shall be after lapse of minimum one (1) & two (2) years respectively from supply completion of first contract.

1.3 The bidder to furnish the following documents, as applicable, in support of the above:

- a) For point 1.2(i): Performance certificates from End-user (duly signed & dated) specifying that the product is performing successfully for one (1) year from date of commissioning along with correlated purchase order(s).
- b) For point 1.2 (ii) & (iv): Purchase order(s), Material dispatch clearance certificate (MDCC)/ Material receipt certificate (MRC)/Lorry receipt (LR)/supply invoice.

1.4 In addition to above, bidder should have the following facilities for Metal expansion bellows of max. size of each type as per BHEL requirement as mentioned in Data sheet of technical specification:

- a) In-house capability of manufacturing metal expansion bellows.
- b) In-house testing facilities for carrying out tests as per relevant standards & Quality plan. In case, the in-house testing facilities are not available, then bidder shall furnish undertaking that test(s) will be carried out from govt. approved lab or test house recognized by reputed customers.

**PREPARED BY:**

*Gaurav Dixit*  
 PE - PS (MPL)  
 DATED 11.10.21

**NAME:** GAURAV DIXIT  
**DESIGNATION:** DY MGR  
**DEPT.:**PS-PEM/ MPL

**REVIEWED BY:**

*Sanjay Kumar*  
 Digitally signed by SANJAY KUMAR  
 DN: cn=SANJAY KUMAR,  
 o=BHEL, ou=PEM,  
 c=IN  
 Date: 2021.10.13 09:38:04  
 +05'30'

**NAME:** SANJAY KUMAR  
**DESIGNATION:** SDGM  
**DEPT.:** PS-PEM/ MPL

**APPROVED BY:**

*Bimal Kumar Agarwal*  
 Digitally signed by Bimal Kumar  
 Agarwal  
 Date: 2021.10.13 09:49:23 +05'30'

**NAME:** B K AGARWAL  
**DESIGNATION:** DH/MPL

501929/2021/PS-PEM-MPL



## PRE - QUALIFYING REQUIREMENTS

DOCUMENT NO: PE-TS-475-000-M052

REVISION NO: 00, DATE: 11.10.2021

SHEET: 2 of 2

Bidder to submit supporting documents (Purchase order (s) / Certificate indicating capacity and details/undertaking of manufacturing & testing facilities) for point (a) & (b) above.

- 1.5 To establish business continuity, bidder is required to submit at least (2) Purchase order for any type of Metal expansion bellows (from Data Sheet Part-1 of technical specification) for minimum 300NB size in last 3 (three) years from date of bid submission as defined by BHEL-PEM in NIT.
2. Bidder to also comply with general points mentioned below:
- 2.1 Offers of the JV companies/ Joint bidders/ bidders having collaboration/ licensing agreement/ MOU/ Indian subsidiaries shall be evaluated as follows:
- If bidder happens to be an Indian subsidiaries of foreign OEM, then the credentials of the foreign OEM can also be considered for meeting PQR.
  - If bidder happens to be the Joint Venture Company, then the credentials of any of JV partners can be also considered for meeting PQR.
  - If bidder happens to be the having valid collaboration agreement/ MOU/ licensing agreement with some other company, then the credentials of collaborator/ MOU partner/ licensing company can also be considered for meeting PQR.

Note: If bidder(s) qualifies on the basis of credentials of his principal/ JV partner/ Collaborator/ joint bidder etc., then the principal/ JV partner/ Collaborator/ MOU partner/ joint bidder shall be responsible for overall design vetting and warranty/ guarantee of the package. The scope matrix clearly defining their respective roles including design vetting, manufacturing of critical component, E&C etc. and warranty/ guarantee shall be submitted along with the offer.

- Bidder to note that the arrangement of bidding (joint bid partners/ collaborator/ MOU partner/ licensing company etc.) once offered to BHEL as a part of bidding documents cannot be changed till the execution of contract(s).
- Consideration of offer shall be subject to customer's approval of bidders, if applicable.
- Bidder to submit all supporting documents in English. If documents submitted by bidder are in language other than English, a self-attested English translated document should also be submitted.
- Notwithstanding anything stated above, BHEL reserves the right to assess the capabilities and capacity of the bidder/collaborators to perform the contract, should the circumstances warrant such assessment in the overall interest of BHEL.
- After satisfactory fulfillment of all the above criteria/requirement, offer shall be considered for further evaluation as per NIT and all the other items of the tender.
- Bidder to ensure that Third Party/customer issued certificates being submitted as proof of PQR qualification should have verifiable details of document/ certificate issuing authority such as name & designation of issuing authority and its organization contact number and email-id etc. In case the same found not available, purchaser has right to reject such document from evaluation.

PREPARED BY:

*Gaurav Dixit -  
DY - MGR (MPL)*  
DATED 11.10.21

**NAME:** GAURAV DIXIT  
**DESIGNATION:** DY MGR  
**DEPT.:** PS-PEM/ MPL

REVIEWED BY:

**SANJAY  
KUMAR**  
Digitally signed by SANJAY  
KUMAR  
DN: cn=SANJAY KUMAR,  
o=BHEL, ou=PEM,  
email=sanjaykumar@bhel.co.in  
Date: 2021.10.13 09:58:29 +05'30'

**NAME:** SANJAY KUMAR  
**DESIGNATION:** SDGM  
**DEPT.:** PS-PEM/ MPL

APPROVED BY:

**Bimal Kumar  
Agarwal**  
Digitally signed by Bimal Kumar  
Agarwal  
Date: 2021.10.13 09:52:52 +05'30'

**NAME:** B K AGARWAL  
**DESIGNATION:** DH/MPL