

ELEVATION

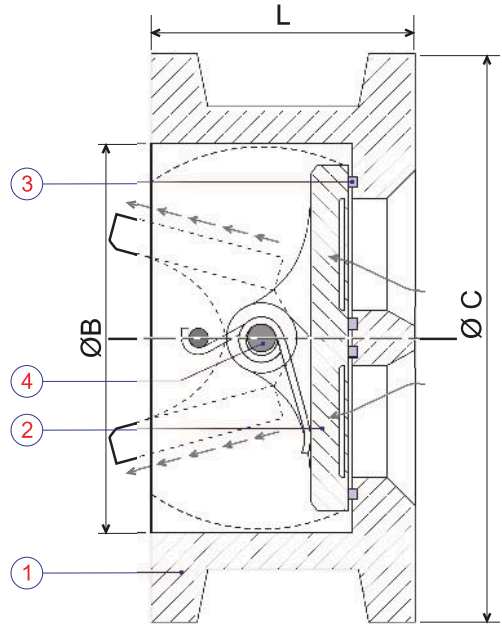

Section A - A

Wall Thk.	Wt./pc Kgs.	SIZE ØNB	L	ØB	ØC	QTY. (Nos.)
6.0	05Kgs	80 (3")	73.0	73.0	137.0	
6.5	08Kgs	100 (4")	73.0	114.0	175.0	02
7.1	14Kgs	150 (6")	98.0	168.0	222.0	04
8.0	26Kgs	200 (8")	127.0	219.0	279.0	02
8.8	45Kgs	250(10")	146.0	273.0	340.0	
		—	± 3.0	± 5.0	+0/-5.0	TOLE.

Sr. No.	Description	Material	Specification
1.	Body	Cast Iron	IS : 210, Gr.- FG 260
2.	Disc / Plate	C. C. S.	ASTM A 216, Gr.- WCB
3.	Seat	Natural Rubber	
4.	Hinge Pin	SS 410.	ASTM A 276, TP 410
5.	Springs	Inconel X750	
6.	Retainer	CS to IS : 1367, Cl.- 4.6	
7.	Bearing	Stainless Steel / PTFE	

Test Pressure in Kg/cm ² (g)	
BODY	— 24 (Hydrostatic)
SEAT	— 16 (Hydrostatic)

NOTES:—

1. Ref. Design / manufacturing Std. : API 594.
2. All Dimensions are in mm, unless otherwise specified.
3. Wafer end shall be suitable for fitment between ASA B16.5, Class 150 flanges.
4. Testing and inspection shall be done as per Approved QP.
5. An arrow indicating direction of "FLOW" shall be marked on valve body.
6. Construction : Full Bore, Soft-seated, Floating Ball, Split Body, Tight shut-off (Class VI).
7. Painting details : 8a) 2 Layers of Zinc Phosphate Epoxy primer, DFT-75 Microns.
8b) 2 Coat of Chlorinated Rubber Paint, Total DFT 60-80 microns,
8c) Color Shade : IS-5 Shade 217 (Sea Green)

Contractor : M/s Root Cooling Water Systems Pvt. Ltd., Noida		Purchase Order No. : RCS-N-0822/18-19, Rev.- 00, Dated : 15-Dec.-2018	
Project : 2x660MW, Ennore SEZ Super Thermal Power Project		Owner : M/s Tamil Nadu Generation & Distribution Corpn. (TANGEDCO)	
Package : Cooling Water Systems		Customer : M/s Bharat Heavy Electricals Ltd, Noida	
	Manufacturer :-	CAST IRON NON-RETURN VALVE Class : PN 16 Rating, Wafer Ends to suit B16.5, Flanges (Dual Plate — Swing Type)	DRN. : AMIT Kr. RANA
	A.V. VALVES LIMITED		CHD. : S. K. PATHAK
	16, Industrial Estate, Nunhai, AGRA 282006 (INDIA)		APPD. :
	Phone : + 91 562 2281202 Fax : + 91 562 2281201 email : avvalves@sancharnet.in		REV. : 01
SCALE : NTS		Doc No.:	AV's DRG. NO. : RK/ 23054
		REV.- 0	DATED : 27 / 05 / 2019
			O.A. No. : 4490
			SHEET NO.- 1 of 1

TECHNICAL DATA SHEET FOR Y-STRAINER

S.NO.	DESCRIPTION	SPECIFICATION
1	Item	Y-Strainer
2	Application	Condenser Water Circuit
3	Serving area	As per valve schedule
4	Size / Quantity	As per valve schedule
4	MAKE	D.S Engineering
5	Product Image (Indicative)	
6	Type	Y-Type Flange End
7	Pressure Rating	PN-16
8	Material Of Construction	
8.1	Body & Bonnet	Cast Iron as per IS210 Gr. FG 260
8.2	Body/Bonnet Bolts	MS 5/8" x 2 1/2" IS Standard
8.3	End Connection	Flanged
8.4	Gasket	Rubber sheet with internal wiring ,3mm thickness/Neoprene Gasket
8.5	Mesh material	SS-304 24G sheet.
8.6	Mesh Size	Φ3mm Hole
8.7	Material of Seals & O-ring	Neoprene
8.8	Whether Permanent Magnet in Base	Yes, for Attract suspended Iron Particle
8.9	Flanges	ASA 16.5 (RF)
9	Top Bolted, Ends Flanged, Drain & Vent Cock.	Yes
9.1	Hydraulic Pressure	
9.2	Pressure Rating	16 Kg/cm ²
10	Test Pressure	24 Kg/cm ²

Note :-

All Dimension are in mm.

Cast Iron Body as per IS 210 Grade 260

Filter / Strainer is of SS 304 Gauge 24 With 3mm Perforation .

Flange As Per BS - 10, Table E / ASA B 16.5

Drain Plug is Provided at the Bottom to Remove Unwanted Particles.

The Strainer is Hydraulically Tested At 16 Kg/cm2.

Magnet Permanent Magnet is Provided Near Drain Plug

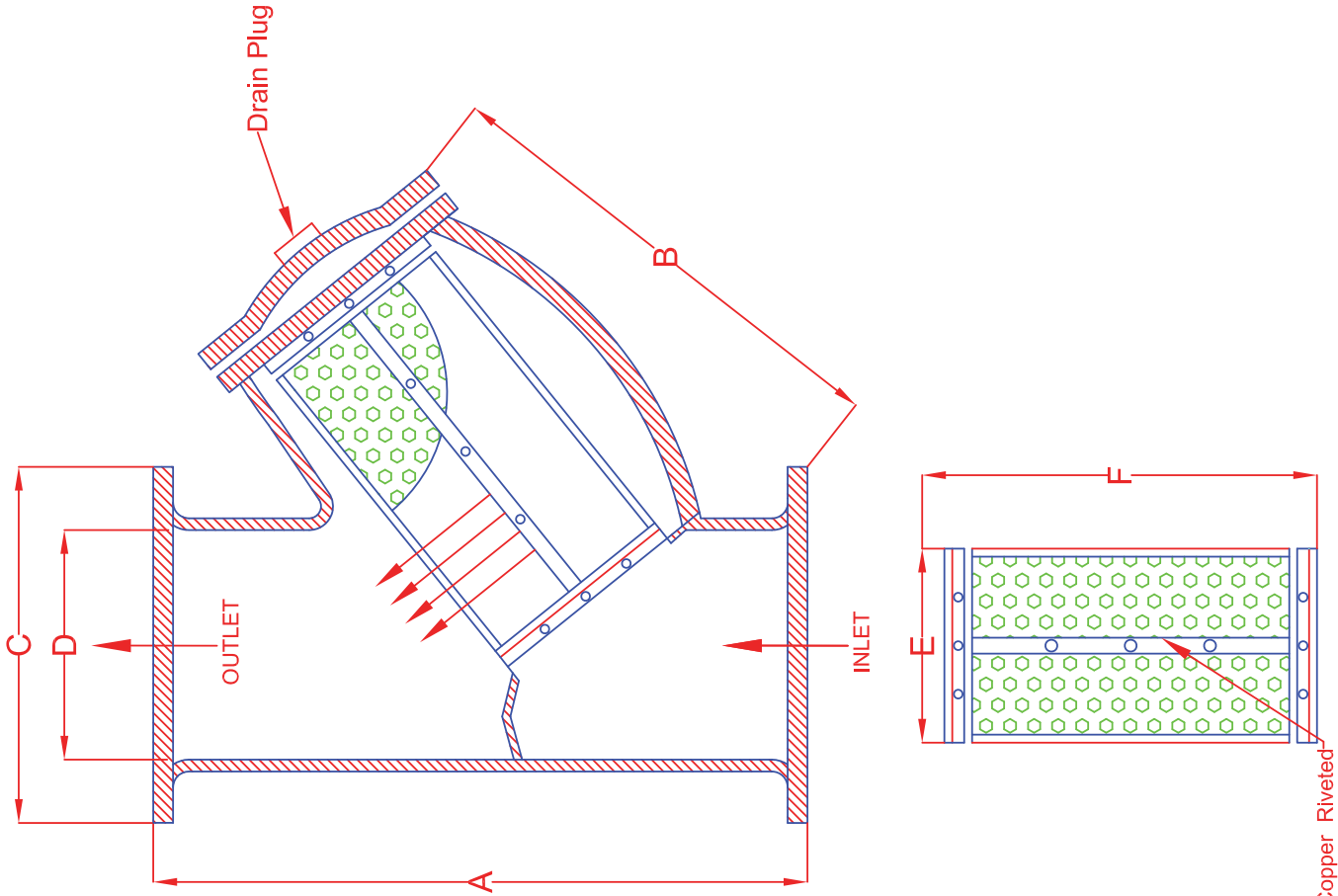

Ø250	535	380	400	250	215	360
Ø200	480	310	335	200	195	295
Ø150	395	255	277	150	140	250
Ø125	372	242	255	128	135	235
Ø100	310	205	215	105	110	205
Ø80	265	175	185	66	75	180
Ø65	250	170	168	67	65	160
Ø50	195	137	150	52	50	130
Ø40	172	120	133	42	40	120
Ø32	155	107	120	33	35	110
Ø25	130	92	115	26	30	90
SIZE	A	B	C	D	E	F



D.S ENGINEERING & MECHANICAL WORKS

CREATED BY :
TARIQUE ALI

CHECKED BY :
MANDEEP

C.I. 'Y' TYPE STRAINER

Page 8 of 46

DATE :20.02.2014 DRG.NO : DS/CI/Y01 REV.NO :

TECHNICAL DATA SHEET FOR POT-STRAINER

S.NO.	DESCRIPTION	SPECIFICATION
1	Item	Pot-Strainer
2	Application	Condenser Water Circuit
3	Serving area	As per valve schedule
4	Size / Quantity	As per valve schedule
4	MAKE	D.S Engineering
5	Product Image (Indicative)	
6	Type	Flange End
7	Pressure Rating	PN-16
8	Material Of Construction	
8.1	Body & Bonnet	MS Heavy Duty Class 'C' MS Pipe(IS 3589) to withstand High Pressure
8.2	Body/Bonnet Bolts	MS 5/8" x 2 1/2" IS Standard
8.3	End Connection	Flanged
8.4	Gasket	Rubber sheet with internal wiring ,3mm thickness/Neoprene Gasket
8.5	Mesh material	SS-304 24G sheet.
8.6	Mesh Size	Φ3mm Hole
8.7	Material of Seals & O-ring	Neoprene
8.8	Whether Permanent Magnet in Base	Yes, for Attract suspended Iron Particle
8.9	Flanges	ASA 16.5 (RF)
9	Basket	Removable basket of SS Sheet, 24 Gauge with 3 mm perforation, Duly Copper riveted. Supported with brass ring & SS angles for more Strength.
9.1	Top Bolted, Ends Flanged, Drain & Vent Cock.	Yes
10	Hydraulic Pressure	
10.1	Pressure Rating	16 Kg/cm ²
10.2	Test Pressure	24 Kg/cm ²

NOTE :

- # ALL Dimension are in mm
- # Shell Made out of MS Sheet of IS-2026/MS 'C' Class Pipe.
- # Filter / Strainer is of SS 304 Gauge.24 With 3mm Perforation.
- # Flanges : As per BS 10. Table E. / ASA B 16.5
- # Drain Plug is Provided at The Bottom to Remove Unwanted Particles.
- # The Strainer is Hydraulically Tested At 16kg/cm2.
- # Magnet Permanent Magnet is Provided Near Drain Plug.

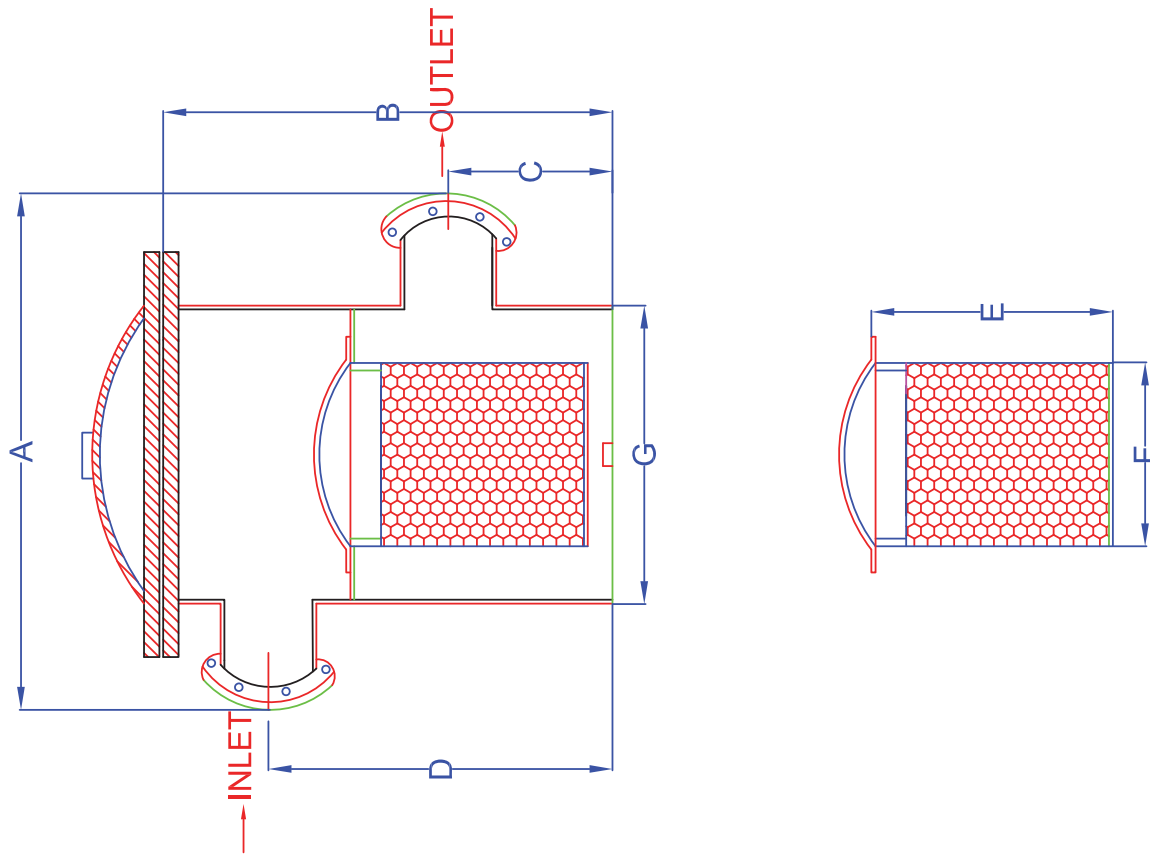

500	900	1200	340	865	510	500	600
400	750	960	320	720	425	415	500
300	655	800	280	605	355	310	406
250	575	685	230	500	305	250	355
200	520	570	200	420	255	215	322
150	435	450	165	335	205	165	272
125	380	380	145	285	200	145	220
100	380	350	135	255	190	125	220
80	325	280	110	200	120	85	168
65	325	250	100	180	120	85	168
50	325	225	85	150	115	70	141
Size	A	B	C	D	E	F	G

D.S.

D.S ENGINEERING & MECHANICAL WORKS.

CREATED BY : TARIQUE ALI

CHECKED BY : MANDEEP

M.S POT STRAINER

DATE : 05.03.2014

DRG.NO :DS/MSP/01

REV.NO :

TECHNICAL DATA SHEET FOR GATE VALVE

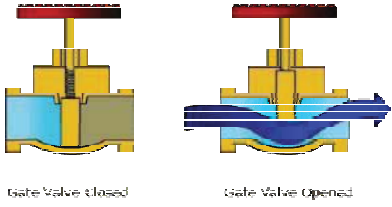
<u>S.NO.</u>	<u>DESCRIPTION</u>	<u>SPECIFICATION</u>
1	Make Name	AV VALVES
2	Size / Quantity	As per valve schedule
3	Serving area	As per valve schedule
4	Product Image (Indicative)	
FOR SIZES 15 TO 40 MM DIA		
5	<u>General</u>	
5.1	Type & operation	Non Rising Stem with hand lever Operated & bolted bonnet & solid wedge
5.2	Pressure Rating	Class 800 Rating
5.3	Test Pressure for body	211 Kg/cmsq
5.4	Test Pressure for seat	154 Kg/cmsq
5.5	Closing	Clockwise
5.6	Operation	Manually operated by hand wheel
5.7	Accessories	All valves are provided with back seat, position indicator, locking arrangement
5.8	<u>Material of Construction</u>	
6	Body, Bonnet , Gland Flange	ASTM A 105N
6.1	Body seat , Spindle & Gland	ASTM A 276, TP 410
6.2	Gland packing	Graphite
6.3	Gasket	Spiral Wound SS 316 with Graphite Filler
6.4	Body bonnet bolts	ASTM A 193, Gr.-B7 H T
6.5	Wedge/Disc ,Sleeve	13 % carbon steel
6.6	Hand Wheel, Wheel Nut	Carbon Steel H T
6.7	Name plate	Aluminum
6.8	Dimension :- Flange to Flange	As per BS 5352
6.9	Painting	i) 2 Layers of Zinc Phosphate epoxy primer, DFT-75 Microns. ii) 2 Coat of Chlorinated Rubber paint, Total DFT 60-80 microns iii) Color shade : IS-5 Shade 217 (Sea Green)
7.0	FOR SIZES 50 TO 300 MM DIA	
	<u>General</u>	
7.1	Type & operation	Non Rising Stem with hand lever Operated & bolted bonnet & solid wedge
7.2	Pressure Rating	PN16
7.3	Test Pressure for body	24 Kg/cmsq
7.4	Test Pressure for seat	15 Kg/cmsq
7.5	Closing	Clockwise
7.6	Operation	Manually operated by hand wheel
7.7	Accessories	All valves are provided with back seat, position indicator, locking arrangement & bevel open gear for 250 NB & above
7.8	<u>Material of Construction</u>	
7.9	Body, Bonnet with Yoke, Wedge ,Gland Follower ,Yoke	IS : 210 Gr.- FG 260
8	Body seat rings & wedge face rings, Bonnet Bush	IS : 318,Gr.-LTB 2
8.1	Sleeve Nut /Back Seat	GM to IS:318 GR.LTB 2
8.2	Gland packing	Graphite Asbestos
8.3	Gasket	Natural Rubber

8.4	Bolts & nuts	CS to IS: 1367 CL.4.6/4.0
8.5	Bonnet Bush	IS : 318, Gr.- LTB 2
8.6	Spindle	SS 410 to AISI :410 (No Casting)
8.7	Yoke Sleeve	ASTM A 439, Gr. – D2
8.8	Hand Wheel, Wheel Nut	Carbon Steel
8.9	Name plate	Aluminum
9.0	Dimension :- Flange to Flange	As per BS 5150.
9.1	Painting	<ul style="list-style-type: none"> i) 2 Layers of Zinc Phosphate epoxy primer , DFT-75 Microns. ii) 2 Coat of Chlorinated Rubber paint, Total DFT 60-80 microns iii) Color shade : IS-5 Shade 217 (Sea Green)

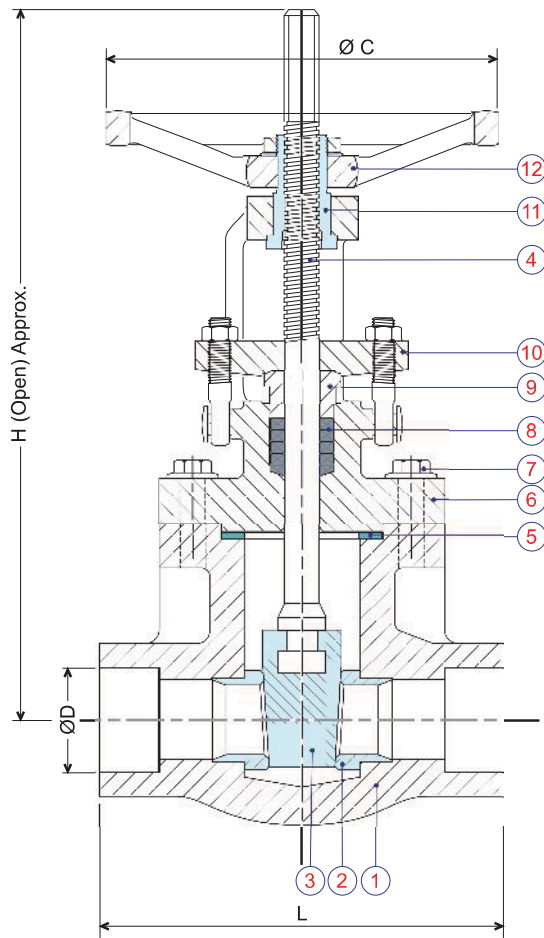

Sr. No.	Description	Material	Specification
1.	Body	F. C. S.	ASTM A 105N
2.	Body Seat	13% Cr.	ASTM A 276, TP 410
3.	Wedge/ Disc	13% Cr. Steel	
4.	Spindle	13% Cr.	ASTM A 276, TP 410
5.	Gasket	Spiral Wound SS316 with Grphh. Filler	
6.	Bonnet	F. C. S.	ASTM A 105N
7.	Body-bonnet Bolt	Steel	ASTM A 193, Gr.- B7 HT
8.	Gland Packing	Graphite	
9.	Gland	13% Cr.	ASTM A 276, TP 410
10.	Gland Flange	F. C. S.	ASTM A 105N
11.	Sleeve	13% Cr. Steel	
12.	Hand Wheel	Carbon Steel	
13.	Name Plate	Aluminum	

Test Pressure		Duration
Shell (Hydro.)	211 Kg/cm ²	60 secs.
Seat (Hydro.)	154 Kg/cm ²	60 secs.
Seat (Pneu.)	06 Kg/cm ²	60 secs.

Wall Thk.	Wt./pc Kgs.	Enq. Sr. No.	SIZE ØNB	L	ØD	H (Approx.)	ØC	Qty. (Nos)
6.0	02 Kgs	1.12	15 (1/2")	85.0	22.0	160.0	105.0	32
8.0	6.5Kgs	1.11	32(1 1/4")	127.0	42.9	270.0	155.0	37
8.2	07Kgs	1.10	40(1 1/2")	127.0	49.0	270.0	155.0	11
				± 2.0	± 0.20	± 25.0	± 5.0	TOLE.

NOTES:—

1. Ref. Design / Testing Code (Std.) : BS : 5352 / BS 6755-1.
2. All Dimensions are in mm, unless otherwise specified.
3. Socket weld Ends are as per ASME B 16.11 (3000#).
4. Testing and inspection shall be done as per Approved QP.
5. Valves shall be supplied with the Position Indicator.
6. An Arrow indicating Direction of Open / Close shall be marked on valve hand-wheel.
7. Valves shall be provided with back seating arrangement to facilitate gland renewal during full open condition.
8. Painting details : 8a) 2 Layers of Zinc Phosphate Epoxy primer, DFT-75 Microns.
8b) 2 Coat of Chlorinated Rubber Paint, Total DFT 60-80 microns,
8c) Color Shade : IS-5 Shade 217 (Sea Green)

Contractor : M/s Root Cooling Water Systems Pvt. Ltd., Noida		Reference : Email Enquiry dated 24-Nov.-2018	
Project : 2x660MW, Ennore SEZ Super Thermal Power Project		Owner : M/s Tamil Nadu Generation & Distribution Corpn. (TANGEDCO)	
Package : Cooling Water Systems		Customer : M/s Bharat Heavy Electricals Ltd, Noida	
 <p>Manufacturer :- A. V. VALVES LIMITED 16, Industrial Estate, Nunhai, AGRA 282006 (INDIA) Phone : + 91 562 2281202 Fax : + 91 562 2281201 email : avvalves@sancharnet.in</p>	<p>FORGED CARBON STEEL GATE VALVE Class : 800 Rating, Socket-weld Ends, H/w Operated (B. B, Outside Screw & Rising Type)</p>		DRN. : AMIT Kr. RANA
			CHD. : S. K. PATHAK
			APPD. :
			REV. : 01
SCALE : NTS		Doc No.:	AV's DRG. NO. : RK/ 22801
		REV.- 0	DATED : 07 / 05 / 2019
			O. A. No. : ENQ.
			SHEET NO.- 1 of 1

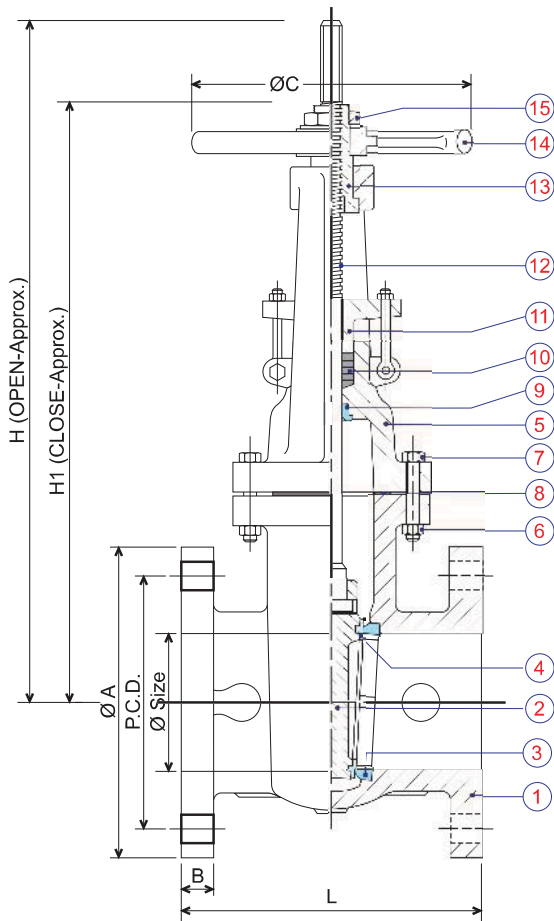

Sl. No.	Description	Material	Specification
1.	Body	Cast Iron	IS : 210, Gr.- FG 260
2.	Wedge	Cast Iron	IS : 210, Gr.- FG 260
3.	Body-seat Ring	Gunmetal	IS : 318, Gr.- LTB 2
4.	Wedge-seat Ring	Gunmetal	IS : 318, Gr.- LTB 2
5.	Bonnet with Yoke	Cast Iron	IS : 210, Gr.- FG 260
6.	Body/bonnet Nut	Steel	IS : 1367, Cl.- 4.0 HT
7.	Body/bonnet Bolts	Steel	IS : 1367, Cl.- 4.6 HT
8.	Gasket	Rubber	Natural Rubber
9.	Bonnet Bush	Gunmetal	IS : 318, Gr.- LTB 2
10.	Gland Packing	Graphited Asbestos	
11.	Gland Follower	Cast Iron	IS : 210, Gr.- FG 260
12.	Spindle	SS 410.	AISI : 410 (No Casting)
13.	Yoke Sleeve	Ni-resist	ASTM A 439, Gr.- D2
14.	Hand Wheel	C. S.	Carbon Steel
15.	Wheel Nut	C. S.	Carbon Steel
16.	Name Plate	Aluminum	

Test Pressure		Duration
Shell (Hydro.)	24 Kg/cm ²	60 secs.
Seat (Hydro.)	15 Kg/cm ²	60 secs.

Wall Thk.	Wt./pc Kgs.	SIZE ØNB	L	ØC	H (Approx.)	H1 (Approx.)	ØA	B	PCD	Bolt Holes		Qty.Nos. (Main+spare)
										Dia.	Nos.	
7.9	18 Kgs	50 (2")	178.0	200.0	410.0	360.0	152.4	15.9	120.7	19.1	4	34
7.9	27 Kgs	65(2½")	190.5	200.0	500.0	435.0	177.8	17.5	139.7	19.1	4	58
9.5	33 Kgs	80 (3")	203.0	250.0	480.0	395.0	190.5	19.1	152.4	19.1	4	08
12.7	48 Kgs	100 (4")	229.0	250.0	570.0	480.0	228.6	23.8	190.5	19.1	8	10
12.7	70 Kgs	125 (5")	254.0	300.0	675.0	550.0	254.0	23.8	215.9	22.2	8	04
14.2	85 Kgs	150 (6")	267.0	350.0	780.0	625.0	279.4	25.4	241.3	22.2	8	05
—			± 2.0	± 5.0	± 25.0	± 25.0	± 2.0	+ 2.0 - 0.0	± 1.5	± 0.5	TOLERANCE	

NOTES:—

1. Ref. Design / Testing Code (Std.) : BS : 5150 / BS 6755-1.
2. All Dimensions are in mm, unless otherwise specified.
3. Flange and drilling dimensions are as per ANSI B16.5, Class 150#, Flat face (FF).
4. Testing and inspection shall be done as per Approved QP.
5. Valves shall be supplied with the Position Indicator. An Arrow indicating Direction of Open / Close shall be marked on valve hand-wheel.
6. Valves shall be provided with back seating arrangement to facilitate gland renewal during full open condition.
7. Each Valve shall be supplied along with matching flanges
8. Painting details : 8a) 2 Layers of Zinc Phosphate Epoxy primer, DFT-75 Microns.
8b) 2 Coat of Chlorinated Rubber Paint, Total DFT 60-80 microns,
8c) Color Shade : IS-5 Shade 217 (Sea Green)

Contractor : M/s Root Cooling Water Systems Pvt. Ltd., Noida		Reference : Email Enquiry dated 24-Nov.-2018	
Project : 2x660MW, Ennore SEZ Super Thermal Power Project		Owner : M/s Tamil Nadu Generation & Distribution Corpn. (TANGEDCO)	
Package : Cooling Water Systems		Customer : M/s Bharat Heavy Electricals Ltd, Noida	
	Manufacturer :-	CAST IRON GATE VALVE Class : PN 16 Rating, Flange Ends, H/w Operated (B. B, Outside Screw & Rising Type) AV's DRG. NO. : RK/ 22802	DRN. : AMIT Kr. RANA
	A.V. VALVES LIMITED		CHD. : S. K. PATHAK
	16, Industrial Estate, Nunhai, AGRA 282006 (INDIA)		APPD. :
	Phone : + 91 562 2281202 Fax : + 91 562 2281201 email : avvalves@sancharnet.in		REV. : 01
			DATED : 07 / 05 / 2019
SCALE : NTS	Doc No.:	REV.- 0	SHEET NO.- 1 of 1

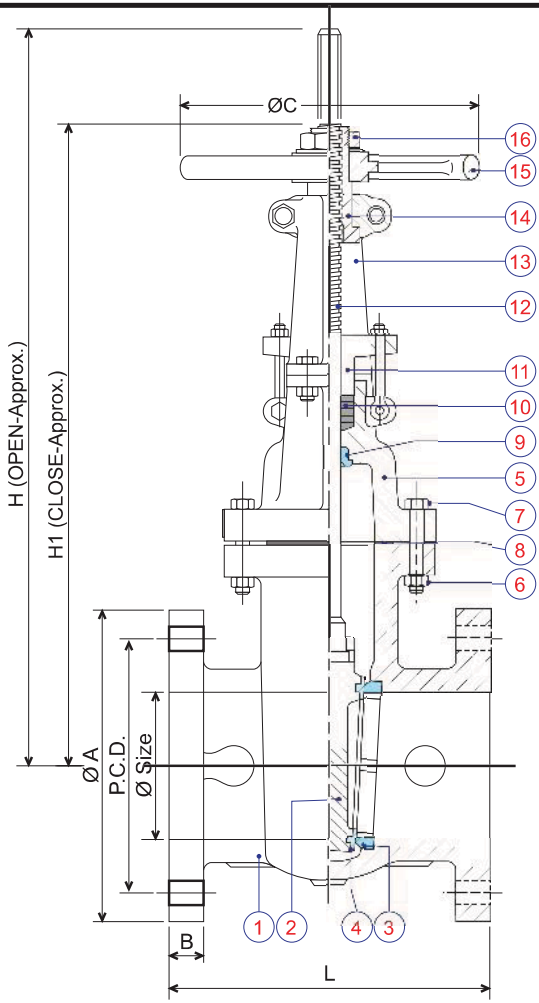

Sl. No.	Description	Material	Specification
1.	Body	Cast Iron	IS : 210, Gr.- FG 260
2.	Wedge	Cast Iron	IS : 210, Gr.- FG 260
3.	Body-seat Ring	Gunmetal	IS : 318, Gr.- LTB 2
4.	Wedge-seat Ring	Gunmetal	IS : 318, Gr.- LTB 2
5.	Bonnet	Cast Iron	IS : 210, Gr.- FG 260
6.	Body/bonnet Nut	Steel	IS : 1367, Cl.- 4.0 HT
7.	Body/bonnet Bolts	Steel	IS : 1367, Cl.- 4.6 HT
8.	Gasket	Rubber	Natural Rubber
9.	Bonnet Bush	Gunmetal	IS : 318, Gr.- LTB 2
10.	Gland Packing	Graphited Asbestos	
11.	Gland Follower	Cast Iron	IS : 210, Gr.- FG 260
12.	Spindle	SS 410.	AISI : 410 (No Casting)
13.	Yoke	Cast Iron	IS : 210, Gr.- FG 260
14.	Yoke Sleeve	Ni-resist	ASTM A 439, Gr.- D2
15.	Hand Wheel	C. S.	Carbon Steel
16.	Wheel Nut	C. S.	Carbon Steel

Test Pressure		Duration
Shell (Hydro.)	24 Kg/cm ²	60 secs.
Seat (Hydro.)	15 Kg/cm ²	60 secs.

Wall Thk.	Wt./pc Kgs.	SIZE ØNB	L	ØC	H (Approx.)	H1 (Approx.)	ØA	B	PCD	Bolt Holes		Qty.Nos. (Main+spare)
										Dia.	Nos.	
15.8	125Kgs	200 (8")	292.0	350.0	1025.0	825.0	342.9	28.6	298.5	22.2	8	06
			± 2.0	± 5.0	± 25.0	± 25.0	± 2.0	+ 2.0 - 0.0	± 1.5	± 0.5	TOLERANCE	

NOTES:—

1. Ref. Design / Testing Code (Std.) : BS : 5150 / BS 6755-1.
2. All Dimensions are in mm, unless otherwise specified.
3. Flange and drilling dimensions are as per ANSI B16.5, Class 150#, Flat face (FF).
4. Testing and inspection shall be done as per Approved QP.
5. Valves shall be supplied with the Position Indicator. An Arrow indicating Direction of Open / Close shall be marked on valve hand-wheel.
6. Valves shall be provided with back seating arrangement to facilitate gland renewal during full open condition.
7. Each Valve shall be supplied along with matching flanges
8. Painting details : 8a) 2 Layers of Zinc Phosphate Epoxy primer, DFT-75 Microns.
8b) 2 Coat of Chlorinated Rubber Paint, Total DFT 60-80 microns,
8c) Color Shade : IS-5 Shade 217 (Sea Green)

Contractor : M/s Root Cooling Water Systems Pvt. Ltd., Noida		Reference : Email Enquiry dated 24-Nov.-2018	
Project : 2x660MW, Ennore SEZ Super Thermal Power Project		Owner : M/s Tamil Nadu Generation & Distribution Corpn. (TANGEDCO)	
Package : Cooling Water Systems		Customer : M/s Bharat Heavy Electricals Ltd, Noida	
	Manufacturer :- A.V. VALVES LIMITED 16, Industrial Estate, Nunhai, AGRA 282006 (INDIA) Phone : + 91 562 2281202 Fax : + 91 562 2281201 email : avvalves@sancharnet.in		CAST IRON GATE VALVE Class : PN 16 Rating, Flange Ends, H/w Operated (B. B, Outside Screw & Rising Type) AV's DRG. NO. : RK/ 22803
			DRN. : AMIT Kr. RANA
			CHD. : S. K. PATHAK
			APPD. :
			REV. : 01
		DATED : 07 / 05 / 2019	
		O.A. No. : ENQ.	
SCALE : NTS	Doc No.:	REV.- 0	SHEET NO.- 1 of 1

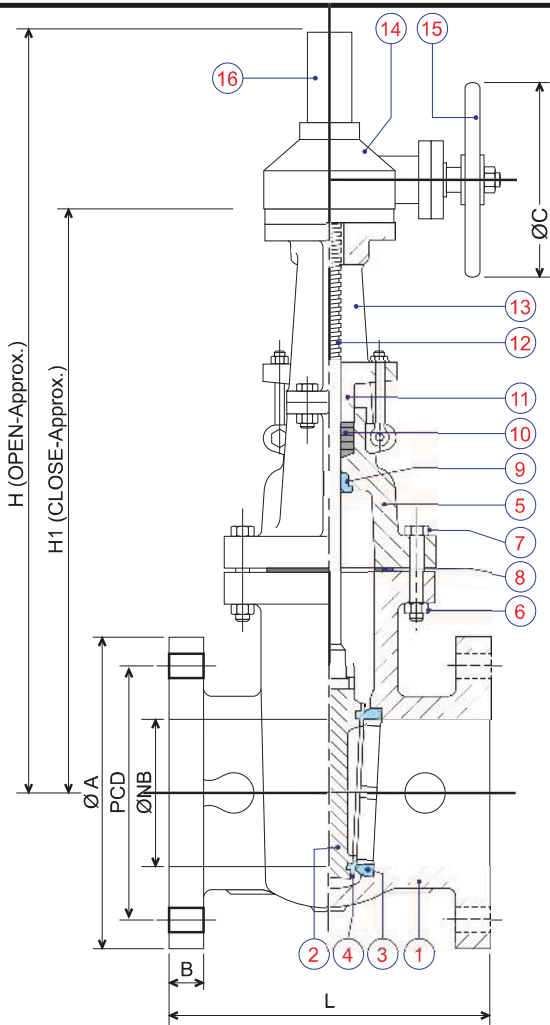

Sl. No.	Description	Material	Specification
1.	Body	Cast Iron	IS : 210, Gr.- FG 260
2.	Wedge	Cast Iron	IS : 210, Gr.- FG 260
3.	Body-seat Ring	Gunmetal	IS : 318, Gr.- LTB 2
4.	Wedge-seat Ring	Gunmetal	IS : 318, Gr.- LTB 2
5.	Bonnet	Cast Iron	IS : 210, Gr.- FG 260
6.	Body/bonnet Nut	Steel	IS : 1367, Cl.- 4.0 HT
7.	Body/bonnet Bolts	Steel	IS : 1367, Cl.- 4.6 HT
8.	Gasket	Rubber	Natural Rubber
9.	Bonnet Bush	Gunmetal	IS : 318, Gr.- LTB 2
10.	Gland Packing	Graphited Asbestos	
11.	Gland Follower	Cast Iron	IS : 210, Gr.- FG 260
12.	Spindle	SS 410.	AISI : 410 (No Casting)
13.	Yoke	Cast Iron	IS : 210, Gr.- FG 260
14.	Bevel Gear Operator	Housing in Cast Iron & Gears of EN-8	
15.	Hand Wheel	C. S.	Carbon Steel
16.	Wheel Nut	C. S.	Carbon Steel

Test Pressure		Duration
Shell (Hydro.)	24 Kg/cm ²	60 secs.
Seat (Hydro.)	15 Kg/cm ²	60 secs.

Wall Thk.	Wt./pc Kgs.	SIZE ØNB	L	ØC	H (Approx.)	H1 (Approx.)	ØA	B	PCD	Bolt Holes		Qty.Nos. (Main+spare)
										Dia.	Nos.	
19.0	210Kgs	250(10")	330.0	400.0	1230.0	980.0	406.4	30.0	362.0	25.4	12	10
20.6	300Kgs	300(12")	355.6	440.0	1450.0	1150.0	482.6	31.8	431.8	25.4	12	11
—			± 2.0	± 5.0	± 25.0	± 25.0	± 2.0	+ 2.0 - 0.0	± 1.5	± 0.5	TOLERANCE	

NOTES:—

1. Ref. Design / Testing Code (Std.) : BS : 5150 / BS 6755-1.
2. All Dimensions are in mm, unless otherwise specified.
3. Flange and drilling dimensions are as per ANSI B16.5, Class 150#, Flat face (FF).
4. Testing and inspection shall be done as per Approved QP.
5. Valves shall be supplied with the Position Indicator. An Arrow indicating Direction of Open / Close shall be marked on valve hand-wheel.
6. Valves shall be provided with back seating arrangement to facilitate gland renewal during full open condition.
7. Each Valve shall be supplied along with matching flanges
8. Painting details : 8a) 2 Layers of Zinc Phosphate Epoxy primer, DFT-75 Microns.
8b) 2 Coat of Chlorinated Rubber Paint, Total DFT 60-80 microns,
8c) Color Shade : IS-5 Shade 217 (Sea Green)

Contractor : M/s Root Cooling Water Systems Pvt. Ltd., Noida		Reference : Email Enquiry dated 24-Nov.-2018	
Project : 2x660MW, Ennore SEZ Super Thermal Power Project		Owner : M/s Tamil Nadu Generation & Distribution Corpn. (TANGEDCO)	
Package : Cooling Water Systems		Customer : M/s Bharat Heavy Electricals Ltd, Noida	
	Manufacturer :- A.V. VALVES LIMITED 16, Industrial Estate, Nunhai, AGRA 282006 (INDIA) Phone : + 91 562 2281202 Fax : + 91 562 2281201 email : avvalves@sancharnet.in		CAST IRON GATE VALVE Class : PN 16 Rating, Flange Ends, H/w Operated (B. B, Outside Screw & Rising Type) AV's DRG. NO. : RK/ 22804
			DRN. : AMIT Kr. RANA
			CHD. : S. K. PATHAK
			APPD. :
		REV. : 01	DATED : 07 / 05 / 2019
		O.A. No. : ENQ.	
SCALE : NTS	Doc No.:	REV.- 0	SHEET NO.- 1 of 1

TECHNICAL DATA SHEET FOR BALL VALVE

S.NO.	DESCRIPTION	SPECIFICATION
1	Make Name	AV VALVES
2	Size / Quantity	As per valve schedule
3	Serving area	As per valve schedule
4	Product Image (Indicative)	
5	General	
5.1	Type	Flanged End, lever operated
5.2	Pressure Rating	Class 150 Rating
5.3	Accessories	All valves are provided with back seat, position indicator, locking arrangement
5.4	Test Pressure for body	30 Kg/Sqcm
5.5	Test Pressure for seat	22 Kg/Sqcm
5.6	Design Standard	BS 5153
5.7	Testing Standard	BS 6755-1
5.8	Material of Construction	
5.9	Body , End Piece	ASTM A 216, Gr - WCB
6.0	Ball	ASTM A 216, Gr – CF 8
6.1	Seat	PTFE
6.2	Body gasket , Stem seal	PTFE / Graphite
6.3	Stud's for body	ASTM A 193, Gr.-B7 HT
6.4	Nut's for Studs	ASTM A 194, Gr.- 2H HT
6.5	Stem , Gland	ASTM A 276, TP 410
6.6	Packing	Graphite
6.7	Handle / lever	Carbon Steel with PVC Sleeve

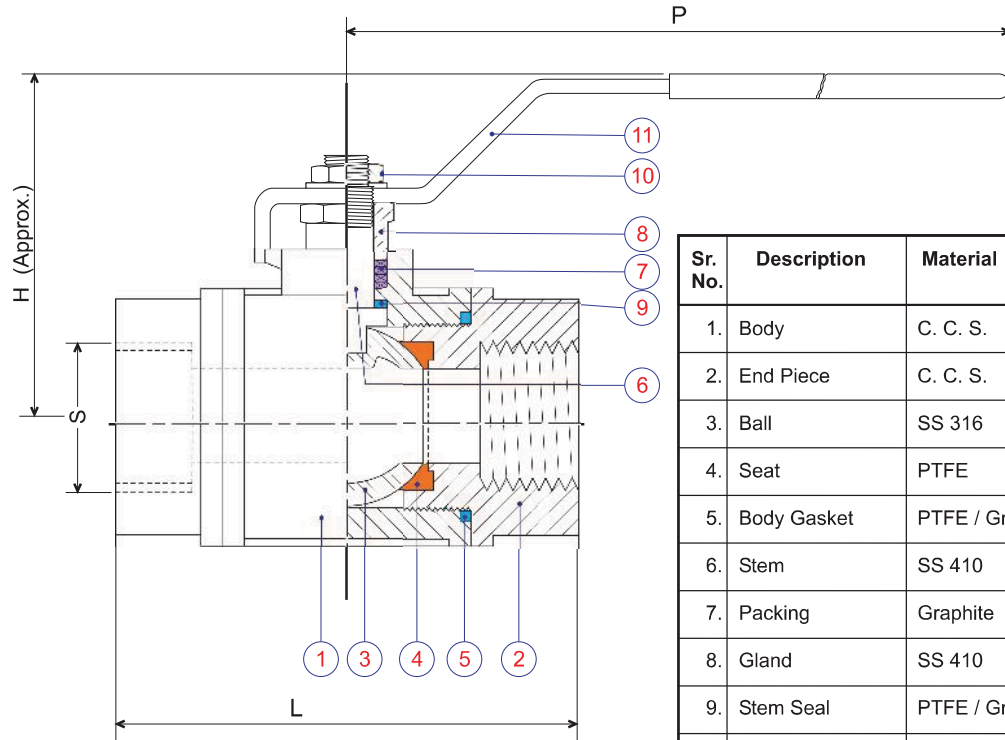

Sr. No.	Description	Material	Specification
1.	Body	C. C. S.	ASTM A 216, Gr.- WCB
2.	End Piece	C. C. S.	ASTM A 216, Gr.- WCB
3.	Ball	SS 316	ASTM A 351, Gr.- CF 8M
4.	Seat	PTFE	
5.	Body Gasket	PTFE / Graphite	
6.	Stem	SS 410	ASTM A 276, TP 410
7.	Packing	Graphite	
8.	Gland	SS 410	ASTM A 276, TP 410
9.	Stem Seal	PTFE / Graphite	
10.	Handle / Lever	Carbon Steel with PVC Sleeve	

Wall Thk.	Wt./pc Kgs.	SIZE ØNB	ØB (Bore)	L	H (Approx.)	P	S	Qty. (Nos)
4.3	55Kgs	32 (1¼")	31.0	100.0	90.0	190.0	1¼"bsp	06
		—	± 1.0	± 3.0	± 15.0	± 25.0	—	TOLE.

Test Pressure		Duration
Shell (Hydro.)	24 Kg/cm ²	60 secs.
Seat (Hydro.)	16 Kg/cm ²	60 secs.
Seat (Pneu.)	06 Kg/cm ²	60 secs.

NOTES:—

1. Ref. Design / Testing Code (Std.) : BS : 5351 / BS 6755-1.
2. All Dimensions are in mm, unless otherwise specified.
3. Screwed shall be as per BSP (Female - Parallel).
4. Testing and inspection shall be done as per Approved QP.
5. Valves shall be supplied with the Position Indicator. An Arrow indicating Direction of Open / Close shall be marked on valve handle.
6. Construction : Full Bore, Soft-seated, Floating Ball, Split Body, Tight shut-off (Class VI).
7. Painting details : 8a) 2 Layers of Zinc Phosphate Epoxy primer, DFT-75 Microns.
8b) 2 Coat of Chlorinated Rubber Paint, Total DFT 60-80 microns,
8c) Color Shade : IS-5 Shade 217 (Sea Green)

Contractor : M/s Root Cooling Water Systems Pvt. Ltd., Noida		Reference : Email Enquiry dated 24-Nov.-2018	
Project : 2x660MW, Ennore SEZ Super Thermal Power Project		Owner : M/s Tamil Nadu Generation & Distribution Corpn. (TANGEDCO)	
Package : Cooling Water Systems		Customer : M/s Bharat Heavy Electricals Ltd, Noida	
	Manufacturer :-	CAST CARBON STEEL BALL VALVE Class : PN 16 Rating, Screwed (BSP-F) End, Lever Operated	DRN. : AMIT Kr. RANA
	A.V. VALVES LIMITED		CHD. : S. K. PATHAK
	16, Industrial Estate, Nunhai, AGRA 282006 (INDIA)		APPD. :
	Phone : + 91 562 2281202 Fax : + 91 562 2281201		REV. : 01
	email : avvalves@sancharnet.in		DATED : 07 / 05 / 2019
AV's DRG. NO. : RK/ 22810		O. A. No. : ENQ.	
SCALE : NTS	Doc No.:	REV.- 0	SHEET NO.- 1 of 1

TECHNICAL DATA SHEET FOR MOTORIZED BUTTERFLY VALVE BUTTERFLY VALVE			
S.NO.	DESCRIPTION	SPECIFICATION	
1	Make	SIEMENS	
2	Type	Motorized Butterfly Valve	
3	Model Number	250mm	VKF42.250 + SQL321B270
		200mm	VKF42.200 + SQL321B150
		150mm	VKF42.150 + SQL321B150
		125mm	VKF42.125 + SQL321B50
		100mm	VKF42.100 + SQL321B25
		80mm	VKF42.80 + SQL321B25
		65mm	VKF42.65 + SQL321B25
		50mm	VKF42.50 + SQL321B25
4	PN Class	PN 16 to EN1333	
5	Medium Temperature	-10 to 80 Deg Celcius	
6	Body Material	DN 50 to 150 - Grey Cast Iron EN-GJL 200 (HT200) DN200 to 600- Nodular cast iron EN-GJS-450-10 (QT450-10)	
7	Shaft	Stainless Steel 1.4021 (2Cr13)	
8	Valve Disc	Nodular cast iron EN-GJS-450-10 (QT450-10), Nylon coating	
9	Seat	EPDM	
10	Nominal pressure	1600kPa (PN16)	

TECHNICAL DETAILS FOR BUTTERFLY VALVE ACTUATOR (ON/OFF)		
S.NO.	DESCRIPTION	SPECIFICATION
1	Actuator	Used with 50mm - 600mm Valve (Outdoor application) Torque 30NM to 3600NM
2	Power Supply	230 V +/- 10 %, 50 Hz +/- 5 % AC Supply for 50mm to 350mm
3	Frequency	50 Hz
4	Position Signal	2 Position SPDT
5	External coating	Dry powder coating
6	Degree of Protection	IP65 Water Proof
7	Heating Element	Built in Heating Element
8	Material	Alloy Die Casting Body
9	Ambient Temperature	-10 deg C to +80 deg C
10	Painting	Shall be as per Siemens Standard



ACVATIX™

Butterfly valves PN 16**VKF42..**

-
- Gray cast iron or nodular cast iron valve body
 - DN 50...600
 - k_{vs} 65...37,000 m³/h
 - For fitting with PN 16 counter-flanges to ISO 7005
 - Tight-closing in accordance with ISO 5208, leakage rate A
 - No maintenance required
 - Can be equipped with SQL321B.., SQL361B.. electromotoric actuators, or GEB..1E, GBB..1E, GIB..1E damper actuator

Use

This device is used as motorized or shut-off valves in heating, ventilation and air conditioning systems applications.

- In open and closed circuits
- For 2-position (SPDT) or 3-position controls
- For DC 0...10 V control signals
- For chiller and cooling tower sequencing circuits
- To open or close the flow to a heat exchanger or to complete plant sections

Type summary

Product No.	Stock Number	DN	k_{vs} [m ³ /h]	Top Flange EN ISO 5211	Flow velocity of medium ¹⁾ Water [m/s]	
VKF42.50	S55237-V100	50	65	F07	4.5	
VKF42.65	S55237-V101	65	140			
VKF42.80	S55237-V102	80	210			
VKF42.100	S55237-V103	100	470			
VKF42.125	S55237-V104	125	750			
VKF42.150	S55237-V105	150	1250			
VKF42.200	S55237-V106	200	3100			
VKF42.250	S55237-V107	250	4050			F10
VKF42.300	S55237-V108	300	7500			F12
VKF42.350	S55237-V109	350	10250			F14
VKF42.400	S55237-V110	400	14100			
VKF42.450	S55237-V111	450	18500			F16
VKF42.500	S55237-V112	500	24000			
VKF42.600	S55237-V113	600	37000			

¹⁾ Recommended maximum velocity of flow and the butterfly valve fully open

k_{vs} Nominal flow rate of cold water (5...30 °C) through the fully open butterfly valve by a differential pressure of 100 kPa (1 bar)

Ordering

Butterfly valve, actuator must be ordered separately.

When ordering, please specify the quantity, product name and product number.

Example

Product No.	Stock No.	Product Name	Quantity
VKF42.50	S55237-V100	Butterfly valve	1

Delivery

Butterfly valve and actuator are packed separately.

Rev. No.

Please see chapter "Rev. No" on page 8.

Equipment combinations

Butterfly valve	Electromotoric actuators ¹⁾						
	SQL321B25 SQL361B50	SQL321B50 SQL361B50	SQL321B150 SQL361B150	SQL321B270 SQL361B270	SQL321B570 SQL361B570	SQL321B1400 SQL361B1400	SQL321B2650 SQL361B2650
Δp_s [kPa]							
VKF42.50	700						
VKF42.65	700						
VKF42.80	700						
VKF42.100	700						
VKF42.125		700					
VKF42.150			700				
VKF42.200			700				
VKF42.250				700			
VKF42.300					700		
VKF42.350					700		
VKF42.400						700	
VKF42.450						700	
VKF42.500							700
VKF42.600							700

¹⁾ SQL321B.., SQL361B.. electromotoric actuators can be mounted directly on VKF42.. butterfly valves.

Δp_s Maximum permissible differential pressure at which the motorized butterfly valve will close securely against the pressure (close off pressure).

Product No.	Mounting kit	Damper actuators			
		GEB..1E	GBB...1E	GIB..1E	2*GIB...1E
		Δp_s [kPa]			
VKF42.50	ASK77.9	700			
VKF42.65		700			
VKF42.80	ASK77.10		700		
VKF42.100				700	
VKF42.125	ASK77.11				700
VKF42.150					700

Δp_s Maximum permissible differential pressure at which the motorized butterfly valve will close securely against the pressure (close off pressure).

Actuator overview

Product No.	Operating Voltage	Positioning Signal	Position Feedback Signal	Positioning Time for 90° at 50 Hz [s]	Nominal Torque [Nm]	Flange Connection EN ISO 5211	Data-sheet
SQL321B25	AC 220 V 1 phase	2-position (SPDT)	-	11	25	F07	N4520
SQL321B50		2-position (SPDT)	-	19	50	F07	
SQL361B50		DC 0...10 V	DC 0...10 V	19	50	F07	
SQL321B150		2-position (SPDT)	-	39	150	F07	
SQL361B150		DC 0...10 V	DC 0...10 V	39	150	F07	
SQL321B270		2-position (SPDT)	-	39	270	F10	
SQL361B270		DC 0...10 V	DC 0...10 V	39	270	F10	
SQL321B570		2-position (SPDT)	-	47	570	F12	
SQL361B570		DC 0...10 V	DC 0...10 V	47	570	F12	
SQL321B1400		2-position (SPDT)	-	76	1400	F14	
SQL361B1400		DC 0...10 V	DC 0...10 V	76	1400	F14	
SQL321B2650		2-position (SPDT)	-	105	2650	F16	
SQL361B2650		DC 0...10 V	DC 0...10 V	105	2650	F16	

Type		Operating voltage	Positioning		Torque	Connecting cable	Data sheet
			signal	time			
GEB331.1E	GEB336.1E	AC 230 V	3-position	150 s	15 Nm	0.9 m	N4621
GEB131.1E	GEB136.1E						
GEB161.1E	GEB166.1E		AC 24 V				
GBB331.1E	GBB336.1E	AC 230 V	3-position	150 s	25 Nm	0.9 m	N4626
GBB131.1E	GBB136.1E						
GBB161.1E	GBB166.1E		AC 24 V				
GIB331.1E	GIB336.1E	AC 230 V	3-position	150 s	35 Nm	0.9 m	N4626
GIB131.1E	GIB136.1E						
GIB161.1E	GIB166.1E		AC 24 V				

Mechanical design

Ring format, grey cast iron or nodular cast iron valve body with EPDM seat and multiple shaft bushing.

The seat is also used to seal the flange. There is thus no contact between the medium and the valve body.

The valve has a swing-through disc (angle of rotation 360°). The position of the valve disc is indicated by a notch on the front of the shaft.

Flow diagram

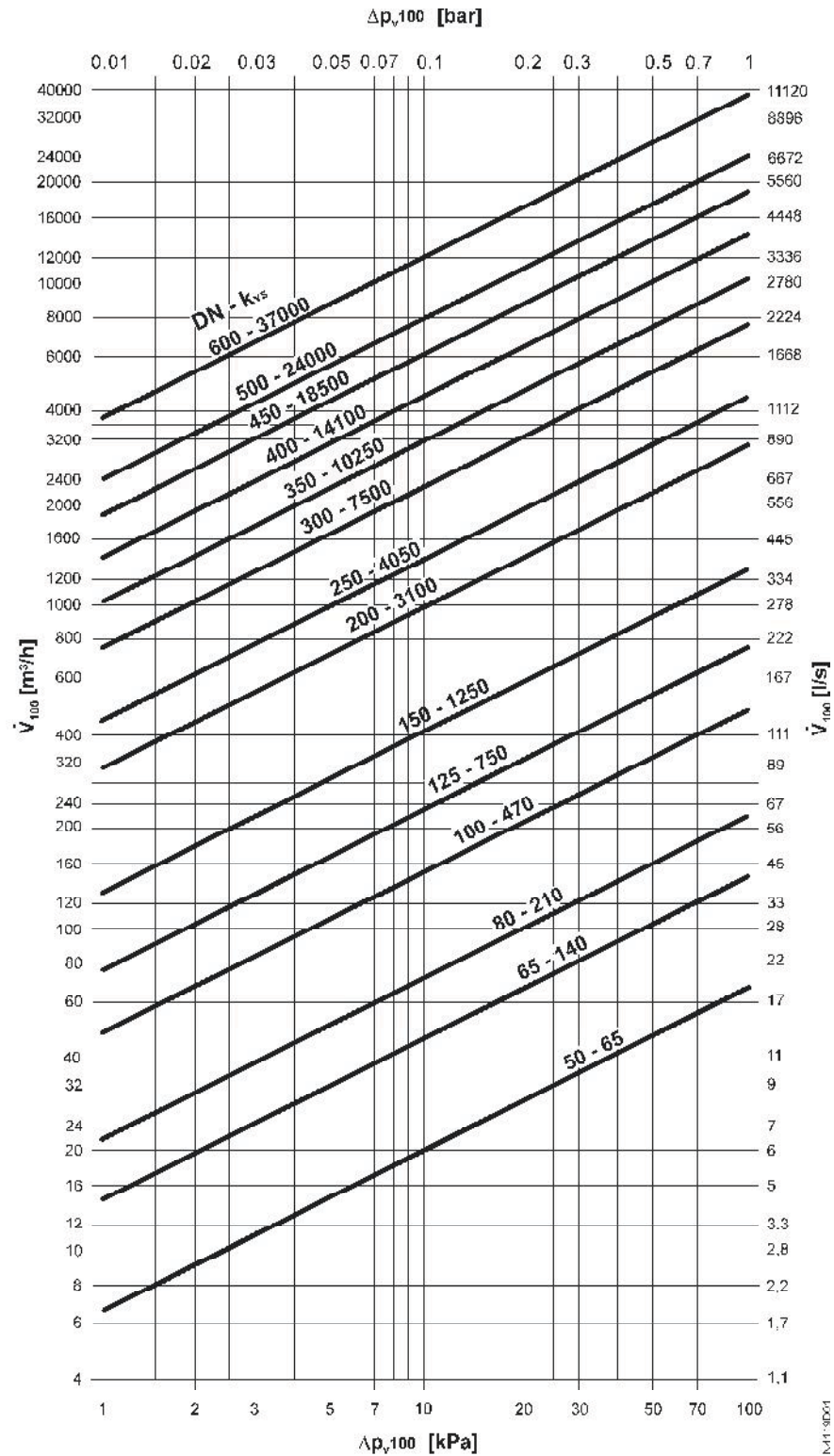

$\Delta p_{v,100}$ = Differential pressure across the fully open butterfly valve by a volume flow \dot{V}_{100}
 \dot{V}_{100} = Volume flow through the fully open butterfly valve
 100 kPa = 1 bar \approx 10 mWC
 $1 m^3/h = 0.278 l/s$ water at 20 °C

Flow characteristic

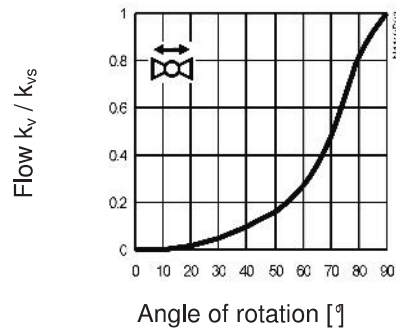

Engineering notes

Single flange mounting is possible: 700 kPa

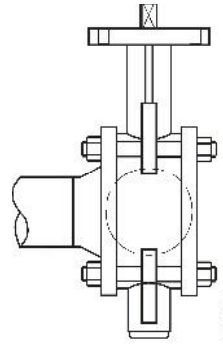

The VKF42.. butterfly valves can accommodate flow in either direction.

Warning



To avoid pressure shocks on the butterfly valve, the VKF42.. must be driven to its fully open position either manually or via control signal Y14 prior to activating the pump(s).

Mounting notes

The mounting instruction 74 319 0808 0 (M4119) is enclosed in the product packaging.

DN 50...200 butterfly valves can be mounted in PN 10, PN 16 applications.

DN 250...600 butterfly valve can be mounted in PN 16 applications only!

Do not use additional flange sealing.

Orientation

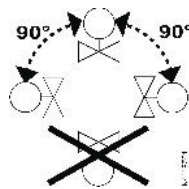

Upright to horizontal

Maintenance notes

The VKF42.. butterfly valves require no maintenance.

Caution



Before performing any service works on the valve, actuator or mounting kit:

- Switch off the pump and power supply
- Close the main shut-off valves in the pipe work
- Release pressure in the pipes and allow them to cool down completely

If necessary, disconnect electrical connections from terminals.

Disposal



The valve must be commissioned only with the actuator correctly assembled.

Before disposal the valve must be dismantled and separated into its various constituent materials.

Legislation may demand special handling of certain components, or it may be sensible from an ecological point of view.

Current local legislation must be observed.

Warranty

The technical data given for these applications is valid only in conjunction with the Siemens actuators as detailed under "Equipment combinations", page 2.

All terms of the warranty will be invalidated by the use of actuators from other manufacturers.

Technical data

Operating data	PN class	PN 16 to EN1333		
	Permissible operating pressure	1600 kPa (16 bar)		
	Flow characteristic	according to the diagram on page 5		
	Leakage rate	A to ISO 5208 (tight-closing)		
	Permissible medium	Chilled water, low temperature hot water, cooling water, brine, demineralized water (softened), water with anti-freeze Recommendation: Water treatment to VDI 2035		
	Medium temperature	-10...80 °C		
	Flange connection for pipes ¹⁾	PN 16 to ISO 7005		
	Face to face dimension	DIN EN 558, series 20		
	Top flange (flange for actuator)	EN ISO 5211		
	Angle of rotation	90°		
	Standards	Environmental compatibility	ISO 14001 (Environment) ISO 9001 (Quality) Directive 2002/95/EC (RoHS)	
		Materials	Body	DN 50...150
	DN 200...600			Nodular cast iron EN-GJS-450-10 (QT450-10)
Shaft			Stainless steel 1.4021 (2Cr13)	
Valve disc			Nodular cast iron EN-GJS-450-10 (QT450-10), Nylon coating	
Dimensions	Seat	EPDM		
			Refer to page 7 "Dimensions"	
Weight			Refer to page 7 "Dimensions"	

¹⁾ VKF42., DN 50...200 are also suited for PN 10

Dimensions (mm)

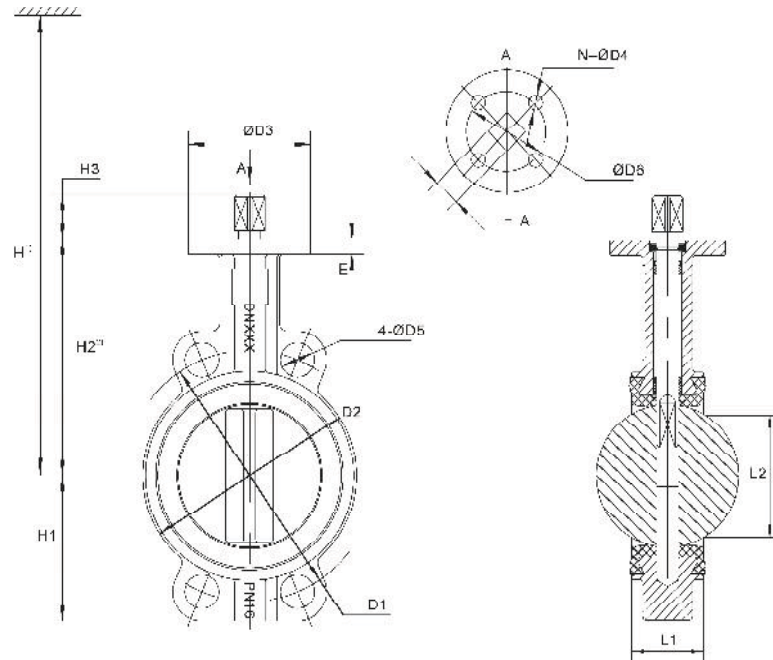

Product No.	DN	L1	L2	H ¹⁾	H1	H2 ²⁾	H3	ØD3	E	PN 16			EN ISO 5211	n-ØD4	ØD6	A	Weight
										D1	D2	ØD5					
VKF42.50	50	42.6	32	594	65	130	14	90	9	125	92	18	F07	4-10	70	11	2.14
VKF42.65	65	45.6	47	607	71	143	14	90	9	145	106	18					2.53
VKF42.80	80	45.6	65	619	92	155	14	90	9	160	122	18					3.31
VKF42.100	100	51.6	91	634	104	170	14	90	11	180	150	18					4.47
VKF42.125	125	55.6	112	654	118	190	19	90	13	210	176	18					6.23
VKF42.150	150	55.6	146	674	132	210	19	90	13	240	204	23	17			7.86	
VKF42.200	200	59.6	194	707	167	243	22	125	15	295	260	23				13.49	
VKF42.250	250	67.6	242	818	198	282	24	125	17	355	316	26	F10	4-12	102	22	21.39
VKF42.300	300	77.6	292	846	230.5	310	29	150	17	410	372	26	F12	4-14	125	27	30.42
VKF42.350	350	79	325	881	257	345	29	150	20	470	415	26					41.94
VKF42.400	400	101.6	380	1118	309	377	45	175	21	525	473	30	F14	4-18	140	36	65.03
VKF42.450	450	113.6	428	1153	349	412	45	175	22	585	531	30					82.40
VKF42.500	500	126.6	474	1181	384	440	50	210	24	650	589	33	F16	4-22	165	46	108.71
VKF42.600	600	153.6	573	1303	477	562	50	210	28	770	700	36					184.71

L1	Corresponds to overall length according to EN 558, series 20
H ¹⁾	Overall height of valve and actuator
=	Valve installation height (H2) from middle of pipe
+	Installation height of actuator
	- SQL321B25 = 195 mm (DN50...100)
	- SQL3..1B50, SQL3..1B150 = 264 mm (DN50...200)
	- SQL3..1B270, SQL3..1B570 = 336 mm (DN250...350)
	- SQL3..1B1400, SQL3..1B2650 = 541 mm (DN400...600)
+	Minimum clearance (≥200 mm) from ceiling or wall for mounting, connection, operation, service etc.
H2 ²⁾	Dimension for actuator connection from centre of pipe

Revision numbers

Product No.	Valid from Rev. No.	Product No.	Valid from Rev. No.	Product No.	Valid from Rev. No.
VKF42.50	..A	VKF42.150	..A	VKF42.400	..A
VKF42.65	..A	VKF42.200	..A	VKF42.450	..A
VKF42.80	..A	VKF42.250	..A	VKF42.500	..A
VKF42.100	..A	VKF42.300	..A	VKF42.600	..A
VKF42.125	..A	VKF42.350	..A		



ACVATIX™

Electromotoric actuators

SQL321B..
SQL361B..

For VKF42.. butterfly valves

-
- **SQL321B..** Operating voltage AC 220 V, 2-position (SPDT) control signal
 - **SQL361B..** Operating voltage AC 220 V, DC 0...10 V control signal
 - Optional 1000 Ω potentiometer and auxiliary switch
 - Nominal angle of rotation 90°
 - Handwheel and position indicator
 - Built-in heating element to avoid condensation
 - Compatible with EN ISO 5211 flanges

Use

For operation of VKF42.. butterfly valves as shutoff and control valves in heating, ventilation and air conditioning plants.

Type summary

Product No.	Stock No.	Operating Voltage	Positioning Signal	Position Feedback Signal	Positioning Time for 90° at 50 Hz [s]	Nominal Torque [Nm]	Flange Connection EN ISO 5211
SQL321B25	S55164-A100	AC 220 V	2-position (SPDT)	-	11	25	F07
SQL321B50	S55164-A101	AC 220 V	2-position (SPDT)	-	19	50	F07
SQL361B50	S55164-A102	AC 220 V	DC 0...10 V	DC 0...10 V	19	50	F07
SQL321B150	S55164-A103	AC 220 V	2-position (SPDT)	-	39	150	F07
SQL361B150	S55164-A104	AC 220 V	DC 0...10 V	DC 0...10 V	39	150	F07
SQL321B270	S55164-A105	AC 220 V	2-position (SPDT)	-	39	270	F10
SQL361B270	S55164-A106	AC 220 V	DC 0...10 V	DC 0...10 V	39	270	F10
SQL321B570	S55164-A107	AC 220 V	2-position (SPDT)	-	47	570	F12
SQL361B570	S55164-A108	AC 220 V	DC 0...10 V	DC 0...10 V	47	570	F12
SQL321B1400	S55164-A109	AC 220 V	2-position (SPDT)	-	76	1400	F14
SQL361B1400	S55164-A110	AC 220 V	DC 0...10 V	DC 0...10 V	76	1400	F14
SQL321B2650	S55164-A111	AC 220 V	2-position (SPDT)	-	105	2650	F16
SQL361B2650	S55164-A112	AC 220 V	DC 0...10 V	DC 0...10 V	105	2650	F16

Ordering

The actuator, butterfly valve and any accessories must be ordered separately.

When ordering, please specify the quantity, product name and product number.

Example

Product No.	Stock No.	Description	Quantity
SQL361B150	S55164-A104	Electromotoric actuator	1
ASC10.21	S55845-Z122	Double auxiliary switch	1

Delivery

The actuator, accessory and butterfly valve are packed separately and delivered as individual items.

Rev. No.

Please see chapter "Rev. No" on page 12.

Equipment combinations

Butterfly Valve	Electromotoric Actuators ¹⁾						
	SQL321B25 SQL361B50	SQL321B50 SQL361B50	SQL321B150 SQL361B150	SQL321B270 SQL361B270	SQL321B570 SQL361B570	SQL321B1400 SQL361B1400	SQL321B2650 SQL361B2650
	Δp_s [kPa]						
VKF42.50	700						
VKF42.65	700						
VKF42.80	700						
VKF42.100	700						
VKF42.125		700					
VKF42.150			700				
VKF42.200			700				
VKF42.250				700			
VKF42.300					700		
VKF42.350					700		
VKF42.400						700	
VKF42.450						700	
VKF42.500							700
VKF42.600							700

¹⁾ SQL321B.., SQL361B.. electromotoric actuators can be mounted directly on VKF42.. butterfly valves.

Δp_s Maximum permissible differential pressure at which the motorized butterfly valve will close securely against the pressure (close off pressure)

Mechanical design

The actuator is driven by a 2-position (SPDT) or DC 0...10 V control signal from the controller and generates a rotary motion which is transferred to the butterfly valve via a driver.

These electromotoric actuators require no maintenance. They have a reversible asynchronous motor which drives the main shaft via gear train, which accommodates the diagonal square head of the butterfly valve. For SQL321B25, the coil spring is fitted with handwheel shaft, handwheel is engaged when pushed in. For others, the worm shaft is fitted with a direct-acting handwheel.

The actuators are 90° rotated so as to work with Siemens VKF42.. butterfly valves. During automatic operation, rotation is stopped by two built-in end-switches.

To prevent the temperature inside the housing from falling below the dew point temperature, the actuators are equipped with a built-in heating element.

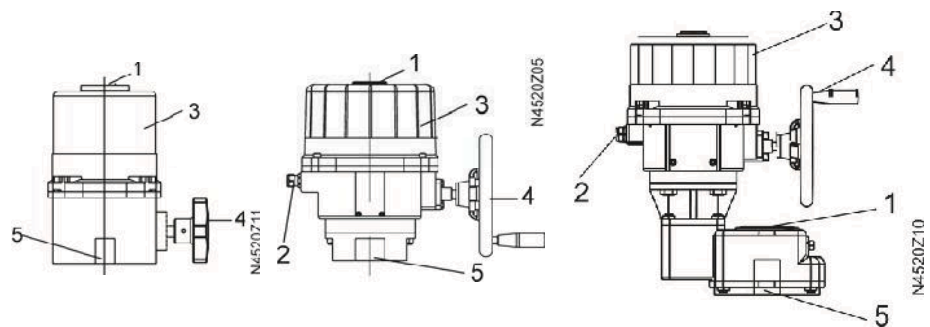







- | | |
|------------------------|---------------------------------|
| 1 Position indication | 4 Handwheel |
| 2 Terminal compartment | 5 EN ISO 5211 flange connection |
| 3 Cover (motor inside) | |

**Calibration
SQL361B..**

In order to determine the disc position fully closed “0%” or fully open “100%”, calibration is recommended on initial commissioning of modulating type actuator.

Prerequisites

- Actuator is mounted on butterfly valve
- Rotate the actuator to the half-open position using the handwheel
- Housing cover is removed

Step	To do	LED on PCB		Actuator action
1. Power supply	<ul style="list-style-type: none"> • Supply power to actuator terminal 1 and 2 • No control signal connected 		Lit	Actuator moves to “0%” (closed) disc position
2. Start calibration	<ul style="list-style-type: none"> • Press button S2 for 5 seconds 		Dark	Actuator remains at “0%” (closed) disc position
3. 0% (close) position	<ul style="list-style-type: none"> • Press button S6 • 0% (closed) value is stored 	 → 	Lit → Dark	When S6 is released actuator moves to 100% (open) disc position
	<ul style="list-style-type: none"> • Wait, actuator moves to open disc position 			
4. 100% (open) position	<ul style="list-style-type: none"> • Press button S7 • 100% (open) value is stored 		Lit	When S7 is released actuator moves to “0%” (closed) disc position
	<ul style="list-style-type: none"> • Wait, actuator moves to close disc position 			
5. Calibration completed	<ul style="list-style-type: none"> • Press button S6 • Calibration is now completed 		Flash	Actuator remains at “0%” (closed) disc position

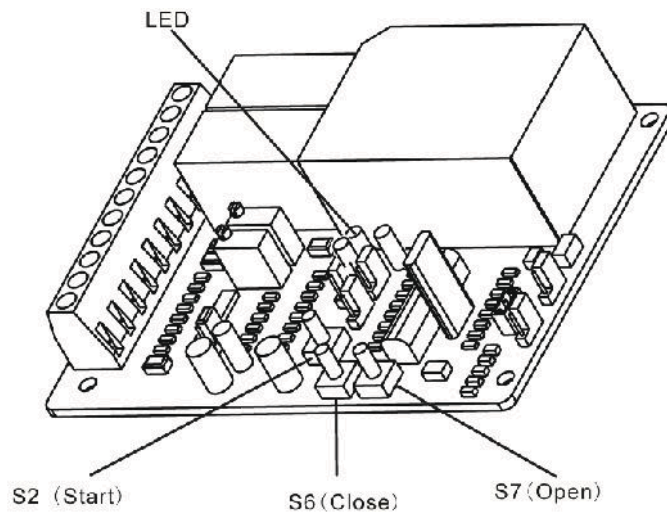

Normal operation

Actuator follows control signal Y, the LED on PCB lights.

Accessories

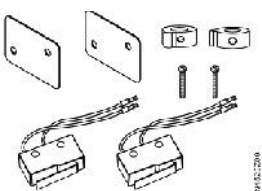
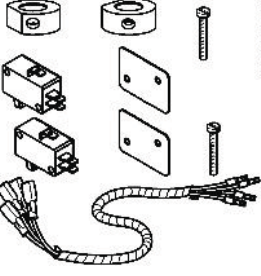
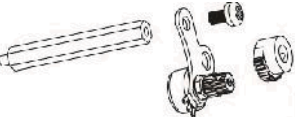
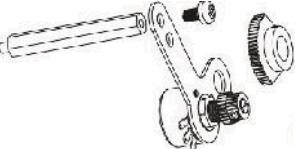
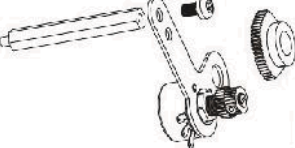
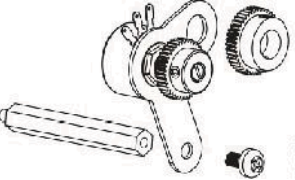
Product No.	Stock No.	Figure	Description	For Actuators
ASC10.20	S55845-Z121		Double auxiliary switch	SQL321B25
ASC10.21	S55845-Z122		Double auxiliary switch	SQL321B50 SQL361B50 SQL321B150 SQL361B150 SQL321B270 SQL361B270 SQL321B570 SQL361B570 SQL321B1400 SQL361B1400 SQL321B2650 SQL361B2650
ASZ10.20	S55845-Z123		Potentiometer 1000 Ω	SQL321B25
ASZ10.21	S55845-Z124		Potentiometer 1000 Ω	SQL321B50 SQL321B150
ASZ10.22	S55845-Z125		Potentiometer 1000 Ω	SQL321B270 SQL321B570
ASZ10.23	S55845-Z126		Potentiometer 1000 Ω	SQL321B1400 SQL321B2650

Engineering notes

Electrical installation

The actuators must be electrically connected in accordance with local regulations and with the connection diagrams.

Warning



Regulations and requirements to ensure the safety of people and property must be always observed.

Mounting notes

Mounting instructions

Product No.	Documentation No.
VKF42..	74 319 0808 0 (M4119)
SQL321B.. / SQL361B..	74 319 0809 0 (M4520)
ASC10..	74 319 0810 0 (M4520.1)
ASZ10..	74 319 0811 0 (M4520.2)

SQL321B.., SQL361B..

These actuators can be mounted directly on type VKF42.. butterfly valves. The butterfly valves have to be closed "0%" when the actuators are mounted onto the valves.

Orientation

The valve and actuator can be assembled on site. There is no need for special tools.

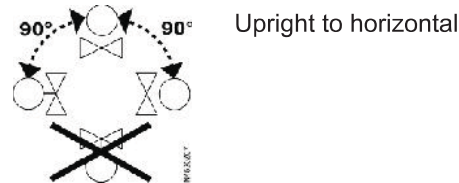

Commissioning notes

When commissioning the motorized butterfly valves, always check wiring and test the functions. This also applies to any additional components fitted, e.g. auxiliary switch.

Warning



To avoid pressure shocks on the butterfly valve, the VKF42.. must be driven to its fully open position either manually or via positioning signal prior to activating the pump(s).

The flow rate can be adjusted either by operating the electric actuators when necessary, or by operating the handwheel.

Operating notes

Manual operation mode

SQL321B25	Handwheel is engaged by pushing the handwheel in.
SQL321B50...B2650 SQL361B50...B2650	The handwheel is always engaged.

Reversing the direction of rotation

If the direction of rotation needs to be reversed, simply exchange the connections Y12 and Y14.

Setting the angle of rotation

The 0...90° angle of rotation for the mechanical limit switches is factory-set and cannot be changed.

The potential-free auxiliary switches are equipped with adjustable switching points.

Maintenance notes

Warning



The actuators and butterfly valves require no maintenance.

Before performing any service work on the valve or actuator:

- Switch off the pump and power supply
- Close the main shut-off valves in the pipe work
- Release pressure in the pipes and allow them to cool down completely

If necessary, disconnect electrical connections from terminals.

The valve must be re-commissioned only with the handwheel or the actuator correctly assembled.

Disposal



The products contain electrical and electronic components and must not be disposed of together with domestic waste. This applies in particular to the printed circuit board.

Legislation may demand special handling of certain components, or it may be sensible from an ecological point of view.

Observe all local and currently valid legislation.

Warranty

The engineering data specified in chapter "Equipment combinations" (page 2) are only guaranteed in connection with the Siemens butterfly valves listed.

Note

When using the actuators in connection with butterfly valves of other manufacture, correct functioning must be ensured by the user, and Siemens will assume no responsibility.

Technical data

	SQL321B25	SQL321B50	SQL321B150	SQL321B270	SQL321B570	SQL321B1400	SQL321B2650
	-	SQL361B50	SQL361B150	SQL361B270	SQL361B570	SQL361B1400	SQL361B2650
Power supply	Operating voltage	AC 220 V / 1 phase					
	Voltage tolerance	+/- 10%					
	Frequency	50 / 60 Hz					
	Power consumption ¹⁾	42 VA	88 VA	91 VA	165 VA	194 VA	361 VA
Signal inputs	Positioning signal SQL321..	2-position (SPDT)					
	SQL361..	DC 0...10 V					
	Parallel operation	For SQL321B.., it is not possible for electrical parallel operation of several actuators. For SQL361B.., electrical parallel operation of several actuators is possible, and the specific quantity of actuator depends on the controller output.					
	Position feedback SQL361..	DC 0...10 V					
Operating data	Positioning time for 90° at 50 Hz	11 s	19 s	39 s	39 s	47 s	105 s
	Angle of rotation	90° ± 1° (factory setting)					
	Nominal Torque ¹⁾	25 Nm	50 Nm	150 Nm	270 Nm	570 Nm	2650 Nm
Auxiliary switch	Switching capacity	AC 250 V, 5 A resistive	AC 250 V, 10 A resistive				
	Heating element (Build in)	220 V 2.0 W	220 V 7.5 W	220 V 8.5 W			
	Max. permissible medium temperature	-10...80 °C					
Degree of protection Standards	Housing upright to horizontal	IP65 as per EN 60529					
	Insulation class	Class I as per EN 60730					
	CE-conformity						
	As per EMC directive	2004/108/EC					
	Immunity	EN 61000-6-2:[2005] Industrial					
	Emissions	EN 61000-6-3:[2007] Residential					
	Electrical safety	EN 60730-1:[2000] +A1:[2004] +A2:[2008] +A12:[2003] +A13:[2004] +A14:[2005] +A16:[2007]					
Low-voltage directive (LVD)	AC 220 V	EN 60730-1:[2000] +A1:[2004] +A2:[2008] +A12:[2003] +A13:[2004] +A14:[2005] +A16:[2007]					
		EN 60730-2-14:[1997] +A1:[2001] +A11:[2005] +A2:[2008]					
	C-tick	N474					
	Environmental compatibility	ISO 9001 (quality) Directive 2002/95/EC (RoHS)					
Dimension weight	Flange / shaft connection types to valve (top flange)	EN ISO 5211		F07	F10	F12	F14
	Dimensions	see "Dimensions", page 11, 12					
	Weight	see "Dimensions", page 11, 12					
	Cable glands	2 x Pg 13.5	2 x Pg 16				
Materials	Housing base, yoke	Die-cast aluminum alloy				Housing: Die-cast aluminum alloy	
						Gear box: Cast Iron	
	Cover	Die-cast aluminum alloy					

¹⁾ These values apply at nominal voltage, ambient temperature of 20 °C and at nominal running time.

General ambient conditions

	Operation EN 60721-3-4	Transport EN 60721-3-2	Storage EN 60721-3-1
Environmental conditions	Class 4K1	Class 2K2	Class 1K3
Temperature	-20...65 °C	-30...65 °C	-5...55 °C
Humidity	15...100% r. h.	<95% r. h.	0...95% r. h.

Connection diagrams

SQL321B..

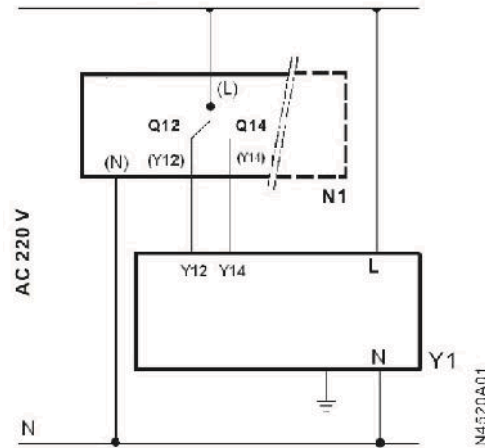

- N1 Controller
- Y1 Actuator
- L 1 phase AC 220 V
- N Neutral
- Q1, Q2 Controller contacts
- Y12 Positioning signal (Closed)
- Y14 Positioning signal (Open)

SQL361B..

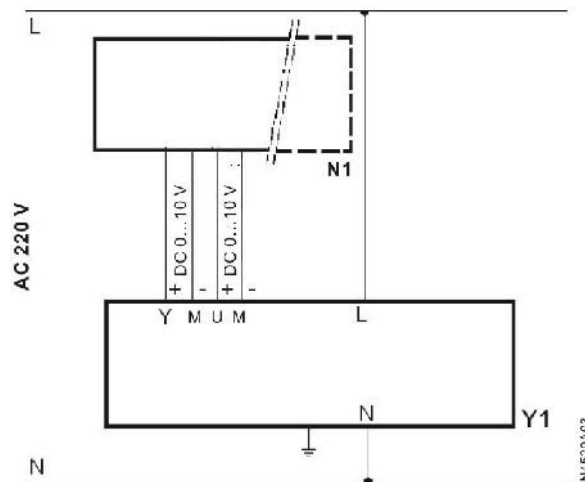

- N1 Controller
- Y1 Actuator
- L 1 phase AC 220 V
- N Neutral
- Y Positioning signal DC 0...10 V
- M Measuring neutral
- U Position feedback signal DC 0...10 V

Dimensions (mm)

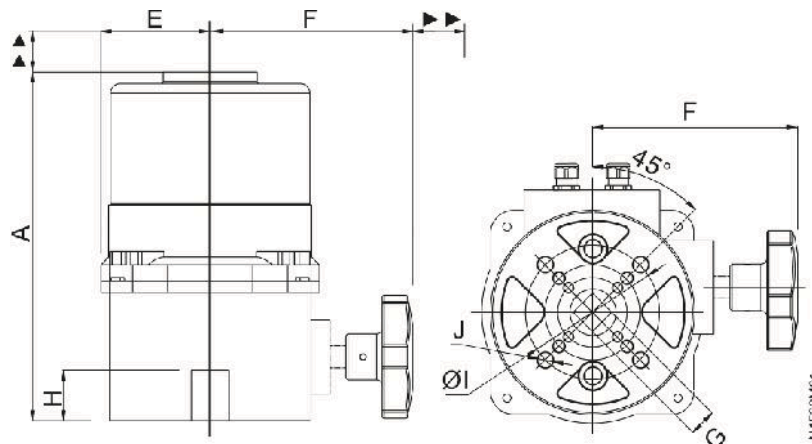

Product No.	A	E	F	H	G	Ø I	J	Weight [kg]	EN ISO 5211
SQL321B25	195	60	110	15	11	70	4-M8	3.6	F07

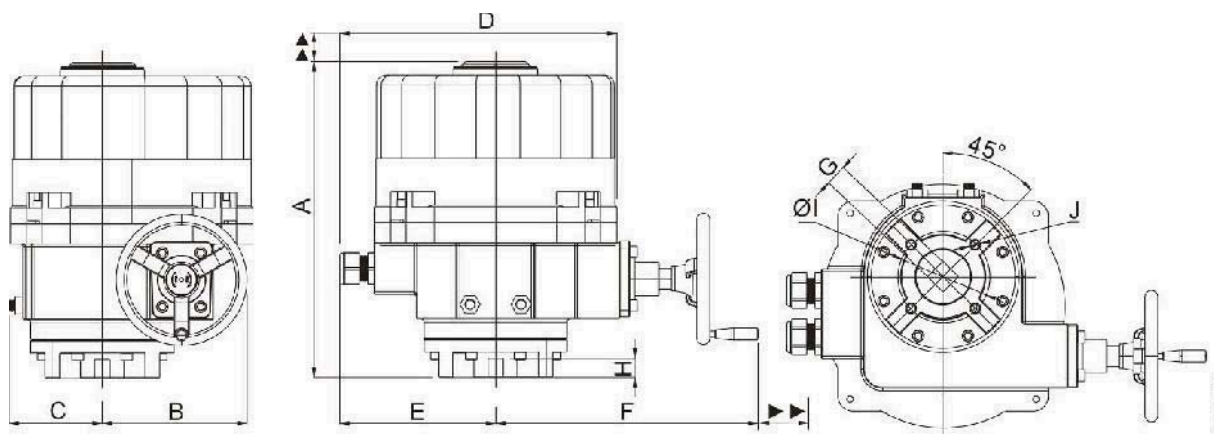

Product No.	A	B	C	D	E	F	G	H	Ø I	J	Weight [kg]	EN ISO 5211
SQL321B50 SQL361B50	264	125	72	213	125	239	17*	35	70	4-M8	11	F07
SQL321B150 SQL361B150	264	125	72	213	125	239	17	35	70	4-M8	11	F07
SQL321B270 SQL361B270	336	154	98	377	148	251	22	55	102	4-M10	22	F10
SQL321B570 SQL361B570	336	154	98	377	148	251	27	55	125	4-M12	22	F12

* Actuator SQL361B50 has one additional bush.

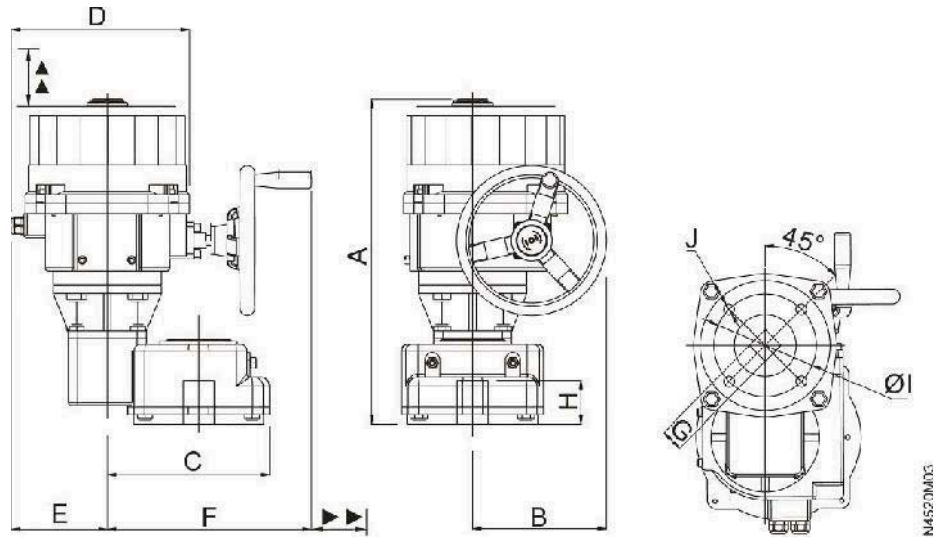

Product No.	A	B	C	D	E	F	G □	H	Ø I	J	Weight [kg]	EN ISO 5211
SQL321B1400 SQL361B1400	541	218	263	295	162	344	36	85	140	4-M16	76	F14
SQL321B2650 SQL361B2650	541	218	263	295	162	344	46	85	165	4-M20	76	F16

▲ ▶▶ ≥ 200 mm: For mounting, connection, operation, service, etc.

Revision numbers

Product No.	Valid from Rev. No.	Product No.	Valid from Rev. No.
SQL321B25	..B	-	-
SQL321B50	..B	SQL361B50	..B
SQL321B150	..B	SQL361B150	..B
SQL321B270	..B	SQL361B270	..B
SQL321B570	..B	SQL361B570	..B
SQL321B1400	..B	SQL361B1400	..B
SQL321B2650	..B	SQL361B2650	..B

TECHNICAL DATA SHEET FOR FLOAT VALVE

S.NO.	DESCRIPTION	SPECIFICATION
1	Make Name	LEADER
2	Size / Quantity	As per valve schedule
3	Serving area	As per valve schedule
4	Product Image (Indicative)	
5	General	
5.1	Body	Gun Metal
5.2	Washer	Nitrile Rubber
5.3	Piston Cap	Gun Metal
5.4	Piston	Gun Metal
5.6	Split Pin	PH Bronze
5.7	Lever	Brass Rod
5.8	Ball Cap	Gun Metal
5.9	Ball	HDPE Copper

SPECIFICATIONS

SCREWED MALE BSP PARALLEL THREADS TO BS 21. OTHER FORMS OF THREADS CAN BE PROVIDED ON REQUEST.

CLASS RATING

PN-10

WORKING PRESSURE/ TEMPERATURE

10 Bar UP TO 45C °

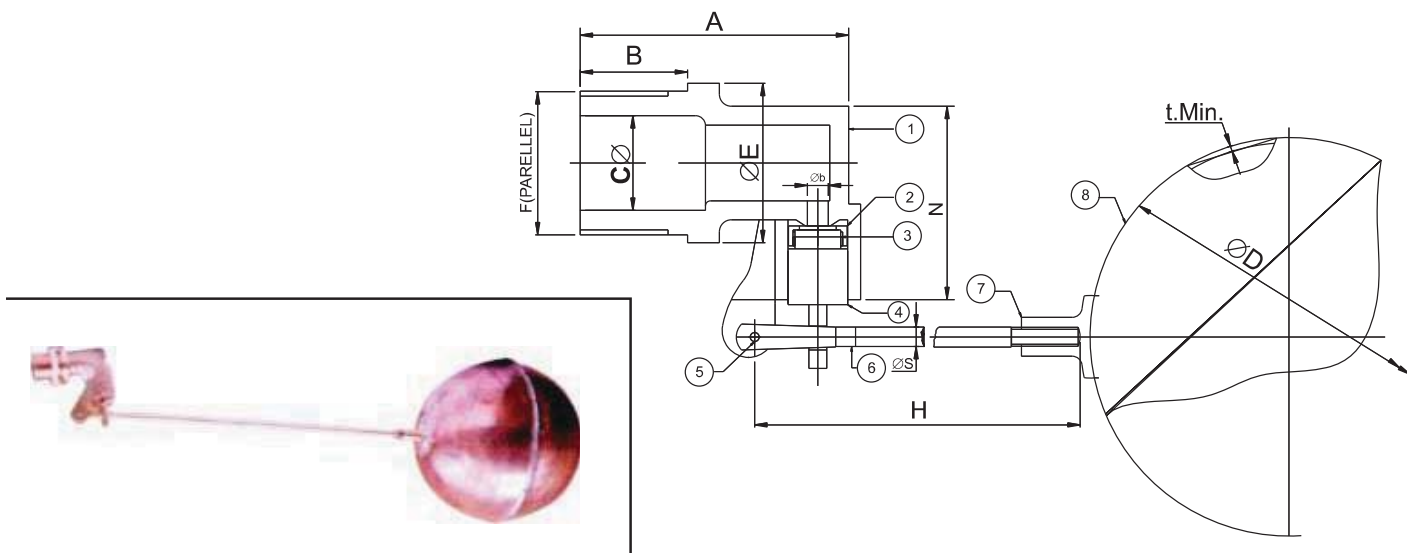

STANDARD MATERIAL COMBINATION

P. NO.	QTY.	DESCRIPTION	MATERIALS	SPECIFICATIONS
1.	1	BODY	GUN METAL	EN 1982 Gr. CC491K
2.	1	WASHER	NITRILE RUBBER	BS: 2751 BA70
3.	1	PISTON CAP	GUN METAL	EN 1982 Gr. CC491K
4.	1	PISTON	GUN METAL	EN 1982 Gr. CC491K
5.	1	SPLIT PIN	PH. BRONZE	BS 2873 PB 102
6.	1	LEVER	BRASS ROD	DIN EN 12165:98 CW721R
7.	1	BALL CAP	GUN METAL	EN 1982 Gr. CC491K
8.	1	BALL	HDPE/COPPER	PEBW A 50 T 090 OF OF IS 7328

DIMENSIONAL DATA

DN	A (mm)	B (mm)	∅C (mm)	∅E (mm)	F (mm)	H (mm)	N (mm)	∅S (mm)	∅b (mm)	∅D (mm)	t (mm)	Aprox. Wt. ^	ITEM CODE NOS.
15	78	38.5	12.5	29.5	1/2	222	40	6.3	5.5	127	1.5		GM 066 D
20	80	37	19	36	3/4	330	45	6.3	6.5	152	2.0		GM 066 F
25	81	30.5	25.4	42	1	406	60	8	7.5	203	2.5		GM 066 G
32	96	38	32	58	1 1/4	571	76	9.5	7.5	229	2.5		GM 066 H
40	114	50	38	67	1 1/2	571	80	9.5	9.5	254	2.5		GM 066 I
50	135	54	47.5	80	2	736	97	10	10.5	305	2.5		GM 066 J
80	185	75	74	105	3	800	139	10	16	355	2.5		GM 066 L

TEST PRESSURES

NOMINAL PRESSURE ACCORDING TO CLASS DESIGNATION	SHELL TEST (HYDROSTATIC)	SEAT (HYDROSTATIC)	STANDARD NO.
PN 10	15 BAR (HYD)	11 BAR (HYD)	

NOTE: The above data is subject to change without notice due to our continuing product improvement program. (^WEIGHT GIVEN IN KGS)

VALVE SCHEDULE MAIN BUILDING				
S.No	DESCRIPTION	SIZE	QTY	LOCATION
CHILLED WATER PUMP				
1	GATE VALVE	250	2	CHW PUMP SUCTION LINE
2	GATE VALVE	200	2	CHW PUMP DISCHARGE LINE
3	Y-STRAINER	250	2	CHW PUMP SUCTION LINE
4	NON RETURN VALVE	200	2	CHW PUMP DISCHARGE LINE
5	BUTTERFLY VALVE-MOTORIZED	200	2	CHW PUMP DISCHARGE LINE
CONDENSOR WATER PUMP				
1	GATE VALVE	300	2	CDW PUMP SUCTION LINE
2	Y-STRAINER	300	2	CDW PUMP SUCTION LINE
3	NON RETURN VALVE	250	2	CDW PUMP DISCHARGE LINE
4	GATE VALVE	250	2	CDW PUMP DISCHARGE LINE
5	BUTTERFLY VALVE-MOTORIZED	250	2	CDW PUMP DISCHARGE LINE
6	POT STRAINER	300	1	CDW PUMP SUCTION LINE
7	GATE VALVE	300	2	CDW POT STRAINER LINE
8	GATE VALVE	300	1	CDW POT STRAINER BYPASS LINE
NON CHEMICAL WATER TREATMENT EQ. ISOLATION				
1	GATE VALVE	250	3	NON CHEMICAL WATER TREATMENT EQ. ISOLATION
CHILLER CHILLED WATER LINE				
1	GATE VALVE	200	4	CHILLER CHILLED WATER LINE
2	BUTTERFLY VALVE-MOTORIZED	200	2	CHILLER CHILLED WATER LINE
3	BALANCING VALVE	200	2	CHILLER CHILLED WATER LINE
4	BALL VALVE	25	4	CHILLER CHILLED WATER DRAIN LINE
CHILLER CONDENSER WATER LINE				
1	GATE VALVE	250	4	CHILLER CONDENSER WATER LINE
2	BUTTERFLY VALVE-MOTORIZED	250	2	CHILLER CONDENSER WATER LINE
3	BALANCING VALVE	250	2	CHILLER CONDENSER WATER LINE
4	BALL VALVE	25	4	CHILLER CHILLED WATER DRAIN LINE
VALVE SCHEDULE-AHU ROOM FOR CCR, EL.+24.00M				
1	GATE VALVE	150	2	AHU CHILLED WATER HEADER
2	BALANCING VALVE	150	1	AHU CHILLED WATER HEADER
3	BUTTERFLY VALVE-MOTORIZED	125	4	AHU CHILLED WATER LINE
4	GATE VALVE	125	8	AHU CHILLED WATER LINE
5	BALANCING VALVE	125	4	AHU BYPASS LINE
6	3-WAY MOTORIZED VALVE	125	4	AHU CHILLED WATER LINE
7	BALANCING VALVE	125	4	AHU CHILLED WATER LINE
8	BALL VALVE	15	2	PAN HUMIDIFIER
9	BALL VALVE	25	1	PAN HUMIDIFIER DRAIN LINE
VALVE SCHEDULE-AHU ROOM FOR UPS CONTROL ROOM, EL+8.50M.				
1	BUTTERFLY VALVE-MOTORIZED	100	2	AHU CHILLED WATER LINE
2	GATE VALVE	100	4	AHU CHILLED WATER LINE
3	BALANCING VALVE	100	2	AHU BYPASS LINE
4	3-WAY MOTORIZED VALVE	100	2	AHU CHILLED WATER LINE
5	BALANCING VALVE	100	2	AHU CHILLED WATER LINE
6	BALL VALVE	15	2	PAN HUMIDIFIER
7	BALL VALVE	25	1	PAN HUMIDIFIER DRAIN LINE
VALVE SCHEDULE-SWAS ROOM UNIT 1&2				
1	GATE VALVE	100	2	FCU CHILLED WATER HEADER
2	BALANCING VALVE	100	1	FCU CHILLED WATER HEADER
3	BALL VALVE WITH STRAINER	25	6	FCU CHILLED WATER LINE

4	BALL VALVE	25	6	FCU CHILLED WATER LINE
5	2-WAY MOTORIZED VALVE	25	6	FCU CHILLED WATER LINE
VALVE SCHEDULE-FRP STORAGE TANK				
1	BUTTERFLY VALVE-MOTORIZED	50	1	MAKE UP LINE
2	GATE VALVE	50	1	MAKE UP LINE
3	GATE VALVE	50	4	MAKE UP TANK FILLING
4	GATE VALVE	40	2	MAKE UP WATER TANK DRAIN LINE
5	GATE VALVE	50	2	MAKE UP WATER TANK TO EXPANSION TANK
6	GATE VALVE	50	2	EXPANSION TANK FILLING
7	GATE VALVE	32	1	EXPANSION TANK DRAIN
8	Float Valve	50	2	MAKE-UP WATER TANK 01 & 02
9	Float Valve	50	1	EXPANSION WATER TANK
VALVE SCHEDULE-COOLING TOWER				
1	BUTTERFLY VALVE-MOTORIZED	250	2	COOLING TOWER INLET LINE
2	GATE VALVE	250	2	COOLING TOWER INLET LINE
3	GATE VALVE	300	2	COOLING TOWER OUTLET LINE
4	GATE VALVE	50	4	COOLING TOWER MAKE UP LINE
5	GATE VALVE	50	2	COOLING TOWER DRAIN & OVERFLOW LINE
6	GATE VALVE	80	2	COOLING TOWER EQUALIZER LINE

VALVE SCHEDULE ESP BUILDING (UNIT-01)				
S.No	DESCRIPTION	SIZE	QTY	LOCATION
1	GATE VALVE	100	2	COOLING TOWER DISCHARGE LINE
		100	2	CONDENSER WATER PUMP SUCTION LINE
		80	2	COOLING TOWER SUCTION LINE
		80	2	CONDENSER WATER PUMP DISCHARGE LINE
		80	3	NON CHEMICAL WATER TREATMENT EQ. ISOLATION
		80	2	CONDENSING UNIT SUCTION LINE
		80	2	CONDENSING UNIT DISCHARGE LINE
		50	2	COOLING TOWER EQUALIZER LINE
		32	5	MAKE-UP WATER SUCTION LINE
		32	2	MAKE-UP WATER TANK DRAIN LINE
2	MOTORIZED BUTTERFLY VALVE	80	2	COOLING TOWER SUCTION LINE
		80	2	CONDENSER WATER PUMP DISCHARGE LINE
		80	2	CONDENSING UNIT DISCHARGE LINE
		32	1	MAKE-UP WATER LINE
3	NON RETURN VALVE	80	2	CONDENSER WATER PUMP DISCHARGE LINE
4	BALANCING VALVE	80	2	CONDENSER UNIT DISCHARGE LINE
5	Y-STRAINER VALVE	100	2	CONDENSER WATER PUMP SUCTION LINE
6	BALL VALVE	32	6	COOLING TOWER MAKE-UP & DRAIN LINE
7	BALL VALVE	25	2	CONDENSER WATER PUMP SUCTION LINE
8	BALL VALVE	25	2	CONDENSER UNIT SUCTION LINE
9	BALL VALVE	25	2	CONDENSER UNIT DISCHARGE LINE
10	BALL VALVE	25	1	PAN HUMIDIFIER DRAIN LINE
11	BALL VALVE	15	2	PAN HUMIDIFIER MAKE-UP LINE
12	FLOAT VALVE	32	2	MAKE-UP WATER TANK 01 & 02
VALVE SCHEDULE ESP BUILDING (UNIT-02)				
S.No	DESCRIPTION	SIZE	QTY	LOCATION
1	GATE VALVE	100	2	COOLING TOWER DISCHARGE LINE
		100	2	CONDENSER WATER PUMP SUCTION LINE
		80	2	COOLING TOWER SUCTION LINE
		80	2	CONDENSER WATER PUMP DISCHARGE LINE
		80	3	NON CHEMICAL WATER TREATMENT EQ. ISOLATION
		80	2	CONDENSING UNIT SUCTION LINE
		80	2	CONDENSING UNIT DISCHARGE LINE
		50	2	COOLING TOWER EQUALIZER LINE
		32	5	MAKE-UP WATER SUCTION LINE
		32	2	MAKE-UP WATER TANK DRAIN LINE
2	MOTORIZED BUTTERFLY VALVE	80	2	COOLING TOWER SUCTION LINE
		80	2	CONDENSER WATER PUMP DISCHARGE LINE
		80	2	CONDENSING UNIT DISCHARGE LINE
		32	1	MAKE-UP WATER LINE
3	NON RETURN VALVE	80	2	CONDENSER WATER PUMP DISCHARGE LINE
4	BALANCING VALVE	80	2	CONDENSER UNIT DISCHARGE LINE
5	Y-STRAINER VALVE	100	2	CONDENSER WATER PUMP SUCTION LINE
6	BALL VALVE	32	6	COOLING TOWER MAKE-UP & DRAIN LINE
7	BALL VALVE	25	2	CONDENSER WATER PUMP SUCTION LINE
8	BALL VALVE	25	2	CONDENSER UNIT SUCTION LINE
9	BALL VALVE	25	2	CONDENSER UNIT DISCHARGE LINE
10	BALL VALVE	25	1	PAN HUMIDIFIER DRAIN LINE
11	BALL VALVE	15	2	PAN HUMIDIFIER MAKE-UP LINE
12	FLOAT VALVE	32	2	MAKE-UP WATER TANK 01 & 02

VALVE SCHEDULE - AC PLANT ROOM, SERVICE BUILDING

S.No	DESCRIPTION	SIZE	QTY	LOCATION
1	GATE VALVE	300	2	COOLING TOWER DISCHARGE LINE
		300	2	CDW PUMP SUCTION LINE
		250	2	COOLING TOWER SUCTION LINE
		250	2	CDW PUMP DISCHARGE LINE
		250	3	NON CHEMICAL WATER TREATMENT EQ. ISOLATION
		80	2	COOLING TOWER EQUALIZER LINE
		50	5	MAKE-UP WATER SUCTION LINE
		50	2	MAKE-UP WATER DISCHARGE LINE
		50	2	MAKE-UP WATER DRAIN LINE
		50	1	MAKE-UP WATER EQUALIZER LINE
2	MOTORIZED BUTTERFLY VALVE	250	2	COOLING TOWER SUCTION LINE
		250	2	CDW PUMP DISCHARGE LINE
		50	1	MAKE-UP WATER LINE
3	NON RETURN VALVE	250	2	CDW PUMP DISCHARGE LINE
4	Y-STRAINER VALVE	300	2	CDW PUMP SUCTION LINE
5	BALL VALVE	50	6	COOLING TOWER MAKE-UP & DRAIN LINE
6	BALL VALVE	25	2	CDW PUMP SUCTION LINE
7	FLOAT VALVE	50	2	MAKE-UP WATER TANK 01 & 02

VALVE SCHEDULE - PACKAGE AC ROOM, SERVICE BUILDING

S.No	DESCRIPTION	SIZE	QTY	LOCATION
1	GATE VALVE	65	80	PAC SUCTION / DISCHARGE LINE
2	MOTORIZED BUTTERFLY VALVE	65	40	PAC SUCTION LINE
3	BALANCING VALVE	65	40	PAC DISCHARGE LINE
4	BALL VALVE	25	80	PAC SUCTION / DISCHARGE LINE
5	BALL VALVE	25	10	P.H.E
6	BALL VALVE	15	20	P.H.E

VALVE SCHEDULE - ADMIN BUILDING

S.No	DESCRIPTION	SIZE	QTY	LOCATION
1	GATE VALVE	200	2	COOLING TOWER DISCHARGE LINE
		200	2	COOLING TOWER PUMP SUCTION LINE
		150	2	COOLING TOWER INLET LINE
		150	2	COOLING TOWER PUMP DISCHARGE LINE
		150	3	NON CHEMICAL WATER TREATMENT EQ. ISOLATION
		65	2	COOLING TOWER EQUALIZER LINE
		40	5	MAKE-UP WATER TANK SUCTION LINE
		40	2	MAKE-UP WATER TANK DISCHARGE LINE
		40	2	MAKE-UP WATER TANK DRAIN LINE
2	MOTORIZED BUTTERFLY VALVE	150	2	COOLING TOWER INLET LINE
		150	2	COOLING TOWER PUMP DISCHARGE LINE
		40	1	MAKE-UP WATER TANK LINE
3	NON RETURN VALVE	150	2	COOLING TOWER PUMP DISCHARGE LINE
4	Y-STRAINER VALVE	200	2	COOLING TOWER PUMP SUCTION LINE
5	BALL VALVE	32	6	COOLING TOWER MAKE-UP & DRAIN LINE
6	BALL VALVE	25	2	COOLING TOWER PUMP SUCTION LINE
7	FLOAT VALVE	40	2	FRP MAKE-UP WATER TANK 01 & 02

VALVE SCHEDULE - 0.00 MTR. ZONE-1 PACKAGE AC ROOM, ADMIN BUILDING

S.No	DESCRIPTION	SIZE	QTY	LOCATION
1	GATE VALVE	65	4	PACKAGE AC 1, 2, 3, 4 SUCTION LINE
		65	4	PACKAGE AC 1, 2, 3, 4 DISCHARGE LINE
2	MOTORIZED BUTTERFLY VALVE	65	4	PACKAGE AC 1, 2, 3, 4 SUCTION LINE
3	BALANCING VALVE	65	4	PACKAGE AC 1, 2, 3, 4 DISCHARGE LINE
4	BALL VALVE	25	4	PACKAGE AC 1, 2, 3, 4 SUCTION LINE
		25	4	PACKAGE AC 1, 2, 3, 4 DISCHARGE LINE
5	BALL VALVE	25	1	PAN HUMIDIFIER
6	BALL VALVE	15	2	PAN HUMIDIFIER

VALVE SCHEDULE - 0.00 MTR. ZONE-2 PACKAGE AC ROOM, ADMIN BUILDING



S.No	DESCRIPTION	SIZE	QTY	LOCATION
1	GATE VALVE	65	4	PACKAGE AC 5,6,7 & 8 SUCTION LINE
		65	4	PACKAGE AC 5,6,7 & 8 DISCHARGE LINE
2	MOTORIZED BUTTERFLY VALVE	65	4	PACKAGE AC 5,6,7 & 8 SUCTION LINE
3	BALANCING VALVE	65	4	PACKAGE AC 5,6,7 & 8 DISCHARGE LINE
4	BALL VALVE	25	4	PACKAGE AC 5,6,7 & 8 SUCTION LINE
		25	4	PACKAGE AC 5,6,7 & 8 DISCHARGE LINE
5	BALL VALVE	25	1	PAN HUMIDIFIER
6	BALL VALVE	15	2	PAN HUMIDIFIER

VALVE SCHEDULE - 4.25 MTR. ZONE-1 PACKAGE AC ROOM, ADMIN BUILDING



S.No	DESCRIPTION	SIZE	QTY	LOCATION
1	GATE VALVE	65	4	PACKAGE AC 9,10,11 & 12 SUCTION LINE
		65	4	PACKAGE AC 9,10,11 & 12 DISCHARGE LINE
2	MOTORIZED BUTTERFLY VALVE	65	4	PACKAGE AC 9,10,11 & 12 SUCTION LINE
3	BALANCING VALVE	65	4	PACKAGE AC 9,10,11 & 12 DISCHARGE LINE
4	BALL VALVE	25	4	PACKAGE AC 9,10,11 & 12 SUCTION LINE
		25	4	PACKAGE AC 9,10,11 & 12 DISCHARGE LINE
5	BALL VALVE	25	1	PAN HUMIDIFIER
6	BALL VALVE	15	2	PAN HUMIDIFIER

VALVE SCHEDULE - 4.25 MTR. ZONE-2 PACKAGE AC ROOM, ADMIN BUILDING

S.No	DESCRIPTION	SIZE	QTY	LOCATION
1	GATE VALVE	65	4	PACKAGE AC 13,14,15 & 16 SUCTION LINE
		65	4	PACKAGE AC 13,14,15 & 16 DISCHARGE LINE
2	MOTORIZED BUTTERFLY VALVE	65	4	PACKAGE AC 13,14,15 & 16 SUCTION LINE
3	BALANCING VALVE	65	4	PACKAGE AC 13,14,15 & 16 DISCHARGE LINE
4	BALL VALVE	25	4	PACKAGE AC 13,14,15 & 16 SUCTION LINE
		25	4	PACKAGE AC 13,14,15 & 16 DISCHARGE LINE
5	BALL VALVE	25	1	PAN HUMIDIFIER
6	BALL VALVE	15	2	PAN HUMIDIFIER

	BHARAT HEAVY ELECTRICALS LIMITED PROJECT ENGINEERING MANAGEMENT (MECHANICAL AUXILIARY)
This approval status shall be interpreted as laid down in the contract and it shall not relieve the contractor from his contractual obligation.	
APPROVAL CATEGORY AWARDED = I	
CAT I - Approved CAT II - Approved with Comments as Noted CAT III - Not Approved CAT IV - Reference Drawing	
Name: VIPIN NAUNI	Signature: 

VIPIN NAUNI
 Revised as per TANGEDCO /
 Desein Comments.
 Reviewed by BHEL and
 found in order. Submitted
 for TANGEDCO / Desein
 Approval. 
 2019.01.14 11:40:22 +05'30'

Date	Rev	Description of Revision	ALT	CHD	APPD
PROJECT		2x660 MW ENNORE SEZ COAL BASED STPP AT ASH DYKE OF NCTPS, CHENNAI			
		CUSTOMER TAMILNADU GENERATION AND DISTRIBUTION CORPORATION LIMITED (TANGEDCO)			
		CONSULTANT DESEIN PRIVATE LIMITED DESEIN HOUSE, GREATER KAILASH-II, NEW DELHI			
		EPC CONTRACTOR BHARAT HEAVY ELECTRICALS LTD PS-PEM, PPEI-BUILDING, SECTOR-16A, PLOT NO. 25, NOIDA-201301			

JOB NO.	412		
STATUS	CONTRACT	DOC. NO: PE-V0-412-553-A031	Rev: 01
PACKAGE		AIR CONDITIONING SYSTEM	
TITLE		TDS & GA OF SUPPLY & RETURN AIR DIFFUSER/GRILLE	
PREPARED BY	V.K	-SD-	25/10/2017
CHECKED BY	RSK	-SD-	25/10/2017
APPROVED BY	P.C.	-SD-	25/10/2017

BHEL REPLY TO TANGEDCO / DESEIN COMMENTS		
Document / Drawing Title	TDS AND GA OF GRILLES & DIFFUSERS FOR AIR CONDITIONING SYSTEM	
Document / Drawing No.	PE-V0-412-553-A031	Revision No. 00
Contractor	BHEL	
Contract package	EPC Package	

S.no.	TANGEDCO Comments	BHEL reply	TANGEDCO / DESEIN REPLY
1.	Provide dimensional GA drawings of all diffusers/grilles	Noted and as per comments GA Drawing of all diffusers and grills along with damper details is enclosed in the document for your review and approval.	

TECHNICAL DATA SHEET

GRILLE

S.No.	DESCRIPTION	DETAILS
1	MAKE	SYSTEMAIR
2	SIZE	NECK- AS PER SITE REQUIREMENT
3	MODEL	AL1(RS3)/AL15(RS3)
4	MATERIAL OF GRILLE	EXTRUDED ALUMINIUM SECTION
5	THICKNESS OF MATERIAL	FRAME 1.2 MM(+/-0.1 MM)
		BLADE 5 MM FROM FRONT
6	TYPE OF GRILLE	0/15 DEG DEFLECTION
7	COLOUR	OFFWHITE, OTHER COLOR ARE AVAILBLEON REQUEST
8	FINISH	POWDER COATED
9	MOUNTING	DUCT COLLARS
10	WIDE	MINIMUM SIZE 150 X 150 MM (NECK)
		MAXIMUM SIZE 1800 X 600 MM (NECK) IN SINGLE MODULE
		OR SIZE AS PER SITE REQUIREMENT.

Prepared By



1	2	3	4	5	6	7	8
UNLESS OTHERWISE SPECIFIED ALL DIMENSION ARE IN m.m.					REV NO.	DATE	REVISION
					REV. BY		

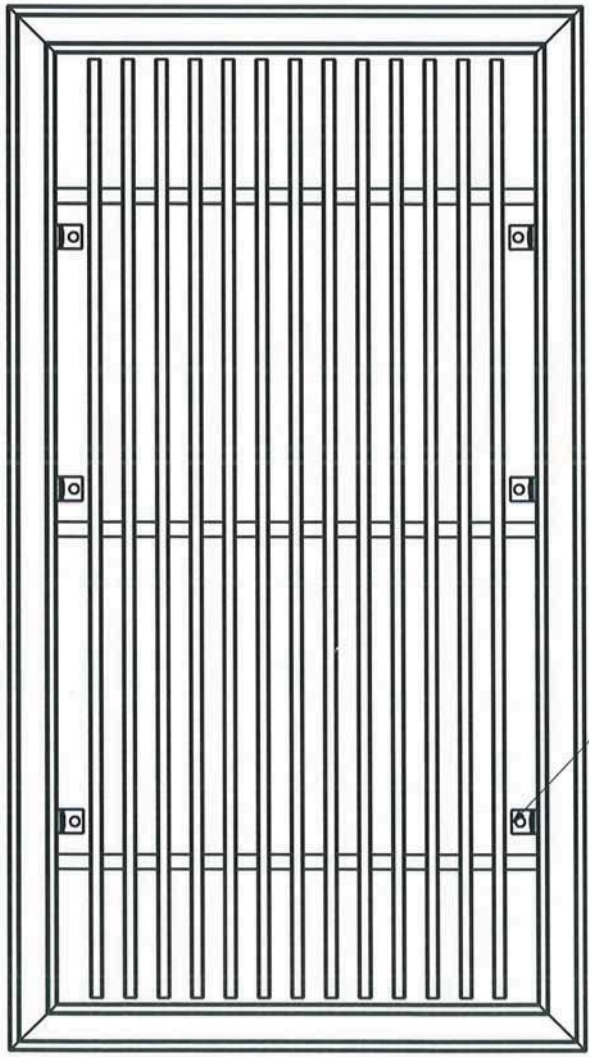
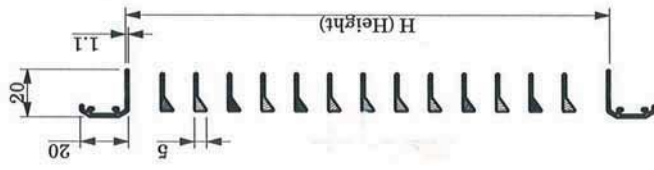

L-ANGLE FOR MOUNTING
NO. OF L-ANGLE MAY DIFFER AS PER SIZE

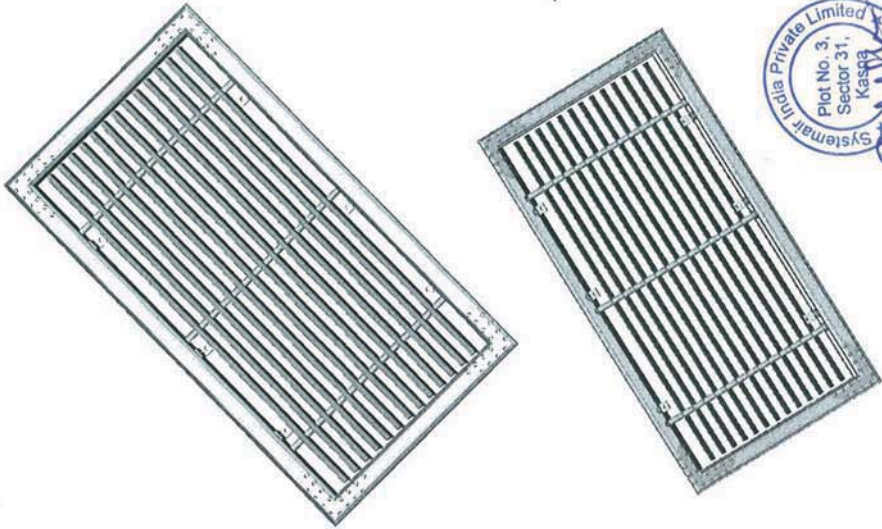

PART DESCRIPTION:		REMOVE SHARP EDGES	DRAWING No.:	REV NO.:
AL15 (RS3)		DATE: 13-Nov-2018	SIPL/ADP/GA/2606	00
MATERIAL:	M. STANDARD:	SCALE:	DRN. BY:	APPD. BY:
-	-	N.T.S.	AMTR	DALIP
		SYSTEMAIR INDIA PVT.LTD.		
<p>THIS DRAWING AND DESIGN IS A PROPERTY OF SYSTEMAIR INDIA PVT. LTD. IS CONFIDENTIAL INFORMATION. SUBJECT TO THEIR RECALL, THE DOCUMENT MUST NOT BE COPIED WITHOUT THEIR WRITTEN PERMISSION. CONTRAVENTION WILL BE PROSECUTED.</p>		<p>REMOVE SHARP EDGES</p>		
<p>TOLERANCE LIMIT UNLESS SPECIFIED:</p> <p>LINEAR DIMENSIONS</p> <p>0.5 - 6 = ±0.3</p> <p>> 6 - 30 = ±0.5</p> <p>> 30 - 120 = ±0.8</p> <p>> 120 - 400 = ±2.0</p> <p>> 400 - 1000 = ±3.0</p> <p>> 1000 - 2000 = ±4.0</p> <p>Over 2000 = ±5.0</p> <p>ANGULAR DIMENSIONS</p> <p>0.5 - 10 = ±4°</p> <p>> 10 - 50 = ±3°</p> <p>> 50 - 120 = ±2°</p> <p>> 120 - 400 = ±1°</p> <p>Over 400 = ±0°40'</p>		<p>MASS PROPERTIES:</p> <p>WEIGHT (kg)</p> <p>VOLUME (mm³)</p> <p>STUR. AREA (mm²)</p> <p>No. of SC/CC</p>		
<p>1</p>		<p>4</p>		
<p>2</p>		<p>4</p>		
<p>3</p>		<p>4</p>		
<p>4</p>		<p>4</p>		
<p>5</p>		<p>4</p>		
<p>6</p>		<p>4</p>		
<p>7</p>		<p>4</p>		
<p>8</p>		<p>4</p>		

TECHNICAL DATA SHEET

DIFFUSER

S.No.	DESCRIPTION	DETAILS
1	MAKE	SYSTEMAIR
2	Type	Square diffuser
3	MODEL	DF(S)
4	CONSTRUCTION	EXTRUDED ALUMINUM
5	MATERIAL OF DIFFUSER	ALUMINIUM – 1.25mm (+/-0.1mm) Border with joint less 1.0mm (+/-0.1mm) die formed core
6	CORE	Removable core Type
7	DEFLECTION	Four Way Type
8	Finish	Powder Coated
9	DAMPER OPERATION	Face Key operated

Prepared By



UNLESS OTHERWISE SPECIFIED ALL DIMENSION ARE IN m.m.

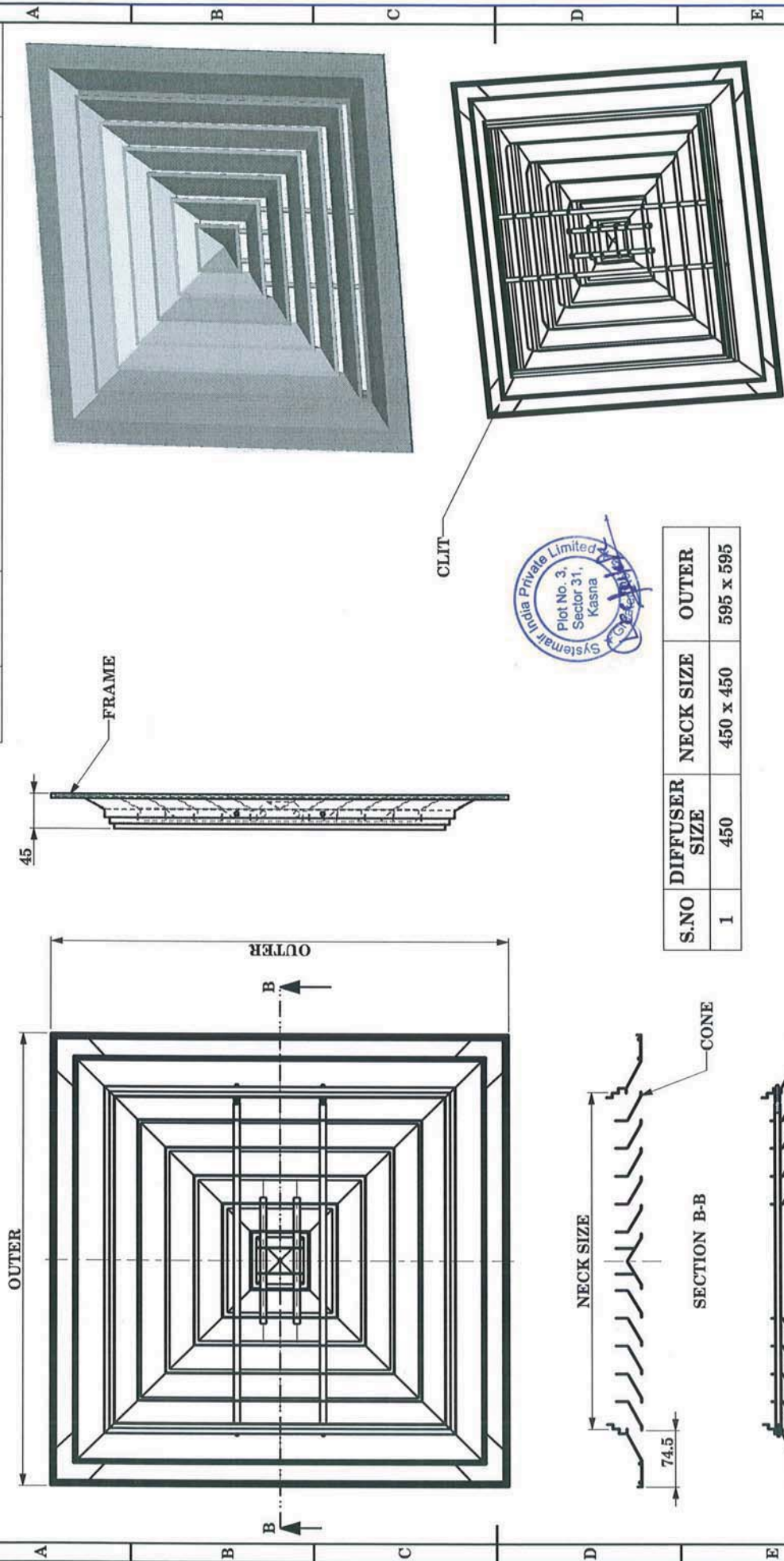

S.NO	DIFFUSER SIZE	NECK SIZE	OUTER
1	450	450 x 450	595 x 595

PART DESCRIPTION:

DIFFUSER DF - GRID

REMOVE SHARP EDGES

REV NO.:

DATE: 06-Aug-2015 SIPL/ADP/GA/1725

DALIP

ATUL

CHD R.F.

DRN. R.F.

SCALE: N.T.S.

M. STANDARD:

MATERIAL:

DATE: 06-Aug-2015 SIPL/ADP/GA/1725

ATUL

CHD R.F.

DRN. R.F.

SCALE: N.T.S.

M. STANDARD:

MATERIAL:

DATE: 06-Aug-2015 SIPL/ADP/GA/1725

ATUL

CHD R.F.

DRN. R.F.

MASS PROPERTIES:

VOLUME (mm ³)	WEIGHT (kg)	No. of SC/CC
-	-	SC
-	-	CC

TOLERANCE LIMIT UNLESS SPECIFIED	0.5 - 6 = ±0.1	120 - 315 = ±1.0	315 - 1000 = ±2.0	1000 - 2000 = ±4.0
30 - 120 = ±0.4	1000 - 2000 = ±4.0			

THIS DRAWING AND DESIGN IS A PROPERTY OF SYSTEMAIR INDIA PVT. LTD. IS CONFIDENTIAL INFORMATION, SUBJECT TO THEIR RECALL. THE DOCUMENT MUST NOT BE COPIED WITHOUT THEIR WRITTEN PERMISSION. CONTRAVENTION WILL BE PROSECUTED.



SYSTEMAIR INDIA PVT.LTD.



TECHNICAL DATA SHEET

MS
DAMPER

S.No.	DESCRIPTION	DETAILS
1	MAKE	SYSTEMAIR
2	SIZE	NECK- AS PER SITE REQUIREMENT
3	MODEL	MS OBSS(COLLAR DAMPER FOR GRILLES/DIFFUSER)
4	MATERIAL OF COLLAR DAMPER	MS Construction
5	THICKNESS OF MATERIAL	BLADE – over all thickness of blade 6mm Aero foil type blade28G(0.38+0.0.38)mm , FRAME - 22 G,
6	TYPE OF VCD	KEY OPERATED OPPOSED BLADE TYPE
7	FINISH	BLACK PAINTED
9	MOUNTING	DUCT COLLARS
10	WIDE	MINIMUM SIZE 100 X 100 MM (NECK) IN SINGLE MODULE
		MAXIMUM SIZE 600 X 600 MM (NECK) IN SINGLE MODULE
		SIZE ABOVE THAN MAX WILL BE IN TWO MODULE

Prepared By



UNLESS OTHERWISE SPECIFIED ALL DIMENSION ARE IN m.m.

REV. NO. DATE REVISION

REV. BY

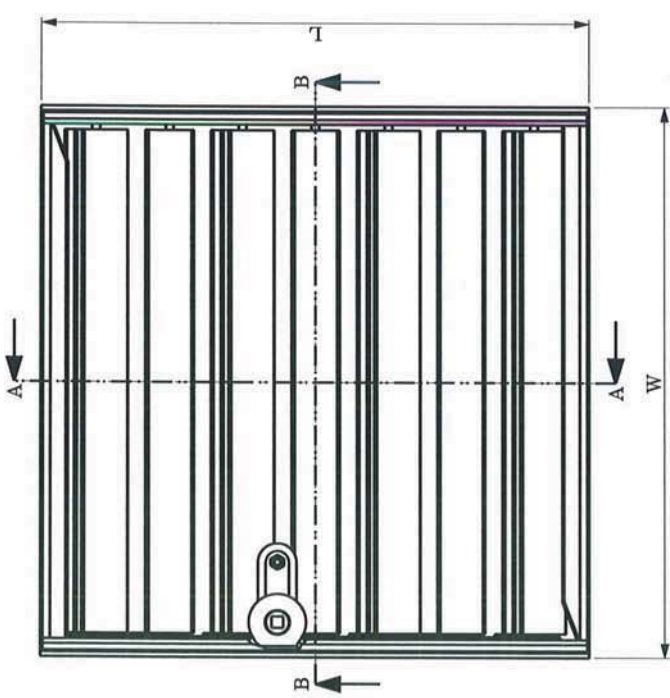

SECTION A-A

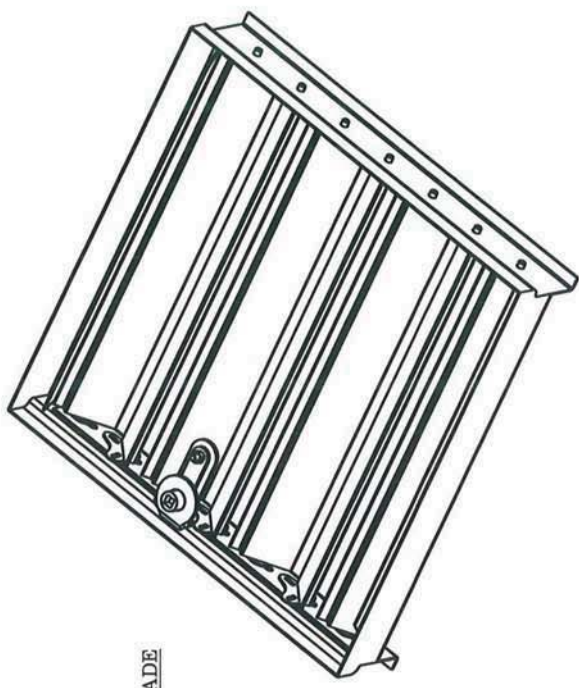
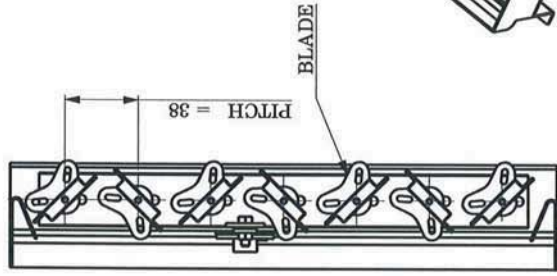

SECTION B-B



PART DESCRIPTION:		REMOVE SHARP EDGES	DRAWING No.:	REV NO.:
MS - OBSS		DATE: 09-Oct-2018	SIPL/ADP/GA/2577	00
MATERIAL:	M. STANDARD:	SCALE:	DEN. BY:	BMM
-	-	N.T.S.	BMM	
systemair		SYSTEMAIR INDIA PVT.LTD.		
APPROVED BY:		APPROVED BY:		
[Signature]		[Signature]		

TOLERANCE LIMIT UNLESS SPECIFIED	MASS PROPERTIES:
LINEAR DIMENSIONS	WEIGHT (kg)
0.5 - 6 = ±2.0	> 120 - 400 = ±8.0
> 6 - 30 = ±4.0	> 400 - 1000 = ±12
> 30 - 120 = ±6.0	> 1000 - 2000 = ±16
Over 2000 = ±20	SUR. AREA (mm²)
ANGULAR DIMENSIONS	No. of SC/CC
0 - 10 = ±8°	SC
> 10 - 30 = ±6°	CC
Over 400 = ±0°40'	

Note: This is only General arrangement drawing, the actual product supplied may deviate from the drawing.

THIS DRAWING AND DESIGN IS A PROPERTY OF SYSTEMAIR INDIA PVT. LTD. IS CONFIDENTIAL INFORMATION, SUBJECT TO THEIR RECALL. THE DOCUMENT MUST NOT BE COPIED WITHOUT THEIR WRITTEN PERMISSION. CONTRAVENTION WILL BE PROSECUTED.

TECHNICAL DATA SHEET

FIRE DAMPER WITHOUT SLEEVE (MOTORIZED)

S.No.	DESCRIPTION	DETAILS
1	MAKE	SYSTEMAIR
2	SIZE	AS PER REQUIREMENT
3	MODEL	WGD
4	REFERENCE CODE/ STANDARD	UL-555,1995 (CERTIFIED BY CBRI)
5	FIRE RATING	120 MINUTES, WITH STAND TEMPERATION - 900Degree Celsius
6	MOUNTING	DUCT MOUNTED
7	BLADE CONSTRUCTION	V- TYPE
8	SHAFT	18mm X 14 mm DIA CIRCULAR ROD code. IS-9550 GRI
9	MATERIAL OF DAMPER	GALVANIZED SHEET, IS277
10	THICKNESS OF DAMPER	FRAME -16 G, LOUVER -16 G
11	MAKE OF SHEET	JINDAL/TATA/BHUSAN/ESSAR/NATIONAL
12	LINKAGE/BUSH ACTUATOR	U TYPE LINKAGE,STEEL IS-9550 FLAT CHROME PLATED HANDLE FOR ACTUATOR
13		BELIMO MAKE ACTUATOR,MODEL- NFA-S2 DEGREE OF PROTECTION – IP54
14	CONTROL PANEL	OPERATING VOLTAGE -220V AC,FREQUENCY 50 Hz, MAKE – CC Indication of power on/off Connect with AHU/FIRE SIGNAL etc.
15	TYPE OF DAMPER	MOTORIZED
16	WIDE	MINIMUM SIZE 300 X 300 MM (NECK) MAXIMUM SIZE 1000 X 1000 MM (NECK) SIZES ABOVE 1000 X 1000 WILL BE IN PARTITION

Prepared By



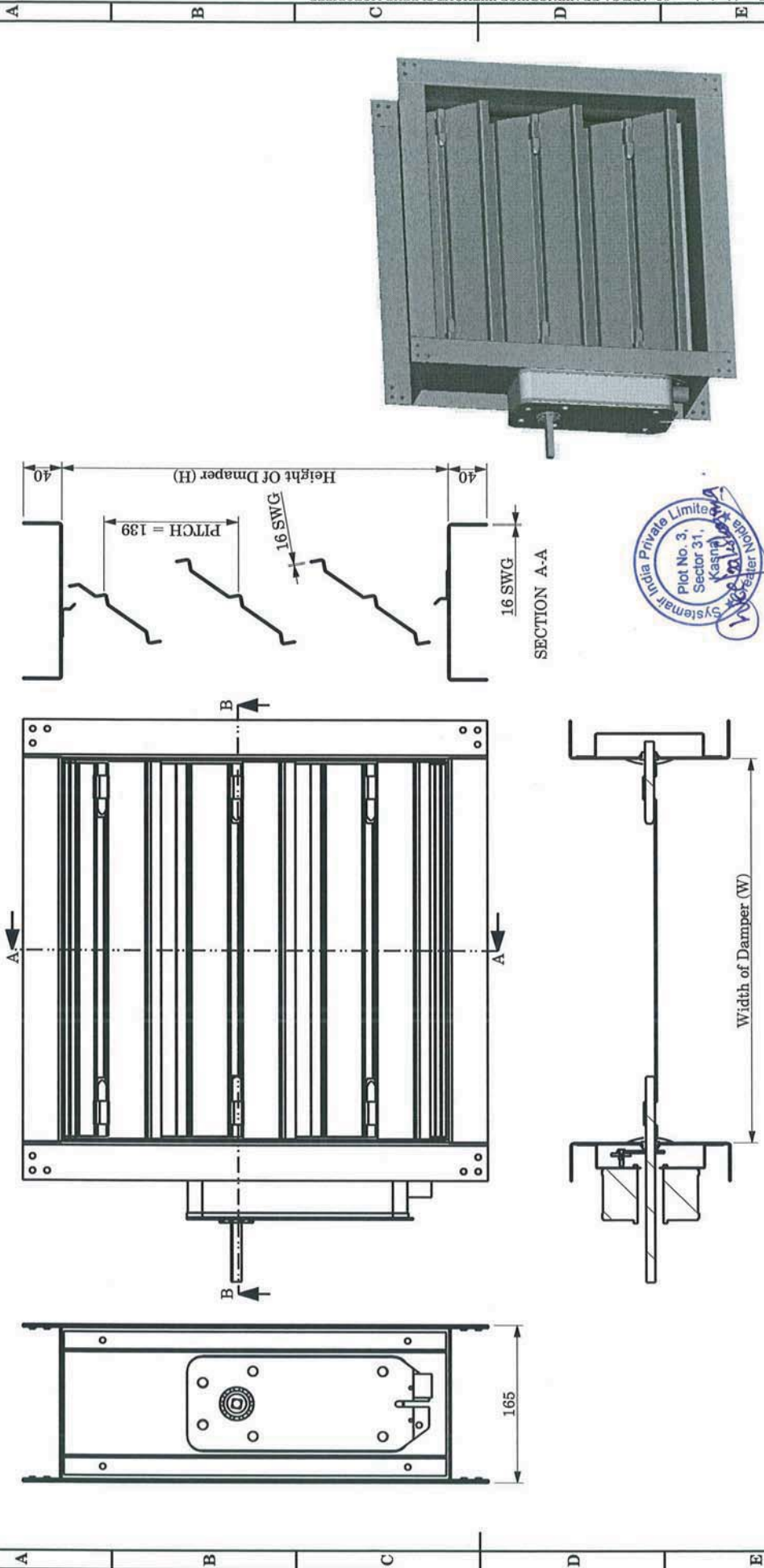

1	2	3	4	5	6	7	8
UNLESS OTHERWISE SPECIFIED ALL DIMENSION ARE IN m.m.				REV NO.	DATE	REVISION	REV. BY



PART DESCRIPTION:		REMOVE SHARP EDGES	DRAWING No.:	REV NO.:
WGD - WITHOUT SLEEVE - MOTORIZED		DATE: 13-Nov-2018	SIPL/ADP/GA/2804	00
MATERIAL:	M. STANDARD:	SCALE:	DRN. BY:	APP. BY:
-	-	-	N.T.S.	DALIP
MASS PROPERTIES:		AMTR	CHRD. BY:	ASRANJAN
VOLUME (mm ³)	WEIGHT (kg)	SYSTEMAIR INDIA PVT.LTD.		
-	-	No. of SC/CC		
TOLERANCE LIMIT UNLESS SPECIFIED		0.5 - 6 = ±0.3		
> 120 - 400 = ±2.0		SC		
> 400 - 1000 = ±3.0		CC		
> 6 - 30 = ±0.5		0		
> 30 - 120 = ±0.8		4		
> 1000 - 2000 = ±4.0		2		
THIS DRAWING AND DESIGN IS A PROPERTY OF SYSTEMAIR INDIA PVT. LTD. IS CONFIDENTIAL INFORMATION. SUBJECT TO THEIR RECALL, THE DOCUMENT MUST NOT BE COPIED WITHOUT THEIR WRITTEN PERMISSION. CONTRAVENTION WILL BE PROSECUTED.				

DOCUMENT IS APPROVED IDE TANGEDCO LETTER NO. SE/E/TH&H P/EE-7/M/AEE/M/F.EN SE STPP/D.714 /18 DT. 20.11.2018

	BHARAT HEAVY ELECTRICALS LIMITED PROJECT ENGINEERING MANAGEMENT (MECHANICAL AUXILIARY)
This approval status shall be interpreted as laid down in the contract and it shall not relieve the contractor from his contractual obligation.	
APPROVAL CATEGORY AWARDED = I	
<input checked="" type="checkbox"/> CAT I - Approved <input type="checkbox"/> CAT II - Approved with Comments as Noted <input type="checkbox"/> CAT III - Not Approved <input type="checkbox"/> CAT IV - Reference Drawing	
Name:	VIPIN NAUNI
Signature:	



VIPIN NAUNI
Reviewed and
found in order.
Approved by BHEL.
2017.10.31
10:09:33 +05'30'

Date	Rev	Description of Revision	ALT	CHD	APPD	
PROJECT		2x660 MW ENNORE SEZ COAL BASED STPP AT ASH DYKE OF NCTPS, CHENNAI				
		CUSTOMER TAMILNADU GENERATION AND DISTRIBUTION CORPORATION LIMITED (TANGEDCO)				
		CONSULTANT DESEIN PRIVATE LIMITED DESEIN HOUSE, GREATER KAILASH-II, NEW DELHI				
		EPC CONTRACTOR BHARAT HEAVY ELECTRICALS LTD PS-PEM, PPEI-BUILDING, SECTOR-16A, PLOT NO. 25, NOIDA-201301				
STATUS		CONTRACT			DOC. NO: PE-V0-412-553-A032	Rev: 00
PACKAGE		AIR CONDITIONING SYSTEM				
TITLE		TDS of GI Sheet				



TECHNICAL DATA SHEET OF GSS Sheet and GI duct

S.NO.	DESCRIPTION	SPECIFICATION
A	<u>GI Sheet</u>	
1	Item	Site Fabricated Rectangular GSS Duct
2	Sheet Make	AS PER APPROVED VENDOR LIST
3	Product Image	
4	Material	Galvanized Steel Sheet
5	Standard	IS: 277 for GI Sheet, IS:655 for GI Duct Construction
6	Galvanization Coating	275 GSM
7	Velocity	Not Exceed 7.5 m/sec for main duct and 6 m/s for branch duct.
8	Service Area	As Per Ducting Layout
9	<u>THICKNESS OF SHEET</u>	<u>SIZES OF DUCT (As per IS:655)</u>
9.1	24 Gauge	Up to 750 mm
9.2	22 Gauge	751 mm to 1500mm
9.3	20 Gauge	1501mm to 2250mm
9.4	18 Gauge	Above 2250 mm
10	Duct Support Details	Refer "DWG No: PE-V0-412-553-A038"

DOCUMENT IS APPROVED VIDE TANGEDCO LETTER NO. SE/E/TH&HYP/EE-7/M/AEE/M/F.EN SEZ STPP/D.747 /18 DT. 26.12.2018



	BHARAT HEAVY ELECTRICALS LIMITED PROJECT ENGINEERING MANAGEMENT (MECHANICAL AUXILIARY)
This approval status shall be interpreted as laid down in the contract and it shall not relieve the contractor from his contractual obligation.	
APPROVAL CATEGORY AWARDED = I	
<input checked="" type="checkbox"/> CAT I - Approved <input type="checkbox"/> CAT II - Approved with Comments as Noted <input type="checkbox"/> CAT III - Not Approved <input type="checkbox"/> CAT IV - Reference Drawing	
Name: VIPIN NAUNI	Signature: 

VIPIN NAUNI
Reviewed by BHEL and
found in order. Submitted
for TANGEDCO / Desein
Approval.
2018.12.06 19:20:20
+05'30'

Date	Rev	Description of Revision	ALT	CHD	APPD
PROJECT		2x660 MW ENNORE SEZ COAL BASED STPP AT ASH DYKE OF NCTPS, CHENNAI			
		CUSTOMER TAMILNADU GENERATION AND DISTRIBUTION CORPORATION LIMITED (TANGEDCO)			
		CONSULTANT DESEIN PRIVATE LIMITED DESEIN HOUSE, GREATER KAILASH-II, NEW DELHI			
		EPC CONTRACTOR BHARAT HEAVY ELECTRICALS LTD PS-PEM, PPEI-BUILDING, SECTOR-16A, PLOT NO. 25, NOIDA-201301			

STATUS	CONTRACT	DOC. NO: PE-V0-412-553-A033	Rev:01
PACKAGE	AIR CONDITIONING SYSTEM		
TITLE	TDS of Pipe		

TECHNICAL DATA SHEET FOR PIPE & PIPE FITTINGS

S.NO.	DESCRIPTION	SPECIFICATION
A	<u>MS PIPE</u>	
1	Item	ERW MS Pipe
2	Application	Chilled Water/Condenser Water/Condensate drain
3	MAKE	AS PER APPROVED VENDOR LIST
4	Product Image (Indicative)	
4	Class	Heavy Grade
5	Pipe Sizes up to 150 MM Dia	Confirming to IS :1239, Heavy Grade, GI pipe
6	Pipe Sizes 200 mm Dia and above	Confirming to IS :3589, 6.35mm thick(Min), MS Pipe
B	<u>FITTINGS</u>	
1	Item	GI/MS Pipe Fittings
2	Pipe Sizes 65 to 150 MM Dia	GI Pipe Fitting with Butt Welded / Screw Ends (for GI) as per ASA B16.9, Long Radius (R=1.5D) Thickness – same as per pipe thickness.
3	Pipe Sizes below 65mm Dia	GI Pipe Fitting with Socket welded / Screw End as per ASA B16.11
4	Pipe Sizes 200 mm Dia and above	Fabricated from pipe.
5	Material of pipe fittings	MS Pipe Fabricated for 200NB & Above. GI (ASTM A234 Gr. WPB) for 65 NB to 150 NB. For sizes 50 NB and below, the material shall confirm to ASTM A-105 (Galvanized) or IS:1875 (Galvanized)
6	Flanges	Forged Carbon Steel to ASTM 105 Gr. II, Dimension as per ANSI B 16.5, Rating Min #150
7	All Nuts & Bolts for Flange connection	Hexagonal Head machined Carbon Steel Bolt and Hot Forged Carbon Steel Hexagonal Nuts as per IS 1367 Class 4.6
8	Gasket for Flange Joint	Wire inserted red rubber full face gaskets, 150# ASA standard, min thickness 3.0mm
9	End connection (pipe to pipe)	Bevel end
10	End connection (pipe to valve)	Flanges End, Conforming to ANSI B 16.5
11	Working Water temperature	7° C to Ambient Temperature
12	Type of Joint	Butt Welded/Socket Welded/Screwed
13	Painting for non galvanized ms pipe	External painting - primer coat: two (2) coats of epoxy primer coats. The minimum dft of each coat shall be 35 microns. Finish coat-two (2) coats of high build epoxy paint. The minimum dft of each coat shall be 35 microns. The total dry film thickness of 150 microns
C	<u>COPPER PIPE</u>	
1	Item	Seamless Copper Pipe
2	Application	Refrigerant Piping for DX system
3	MAKE	REPUTED MAKE
4	Product Image (Indicative)	
5	Standard	As per ASTM B68 / ASTM B75
6	Pipe Sizes less than 1" Dia	Annealed seamless soft copper tube, Grade L (min)
7	Pipe Sizes 1" and above	Drawn seamless hard copper tube, Grade L (min)

TECHNICAL DATA SHEET FOR PIPE & PIPE FITTINGS

S.NO.	DESCRIPTION	SPECIFICATION
<u>D</u>	<u>FITTINGS</u>	
1	Item	Copper Fittings
2	Copper Fittings	As per ANSI/ASME B16.50
<u>E</u>	Pipe sizes	As per approved P & ID
<u>F</u>	Quantity	As per system requirement / Layout
<u>G</u>	Inspection & testing	As per Certificate of Conformance (COC)

BUTT WELDING FITTINGS

ALL DIMNS. IN MM.



Nominal Pipe sizes inch	Outside Dia- metre (O.D.)	90° ELBOWS Long Radius		45° ELBOWS Long Radius		90° ELBOWS SHORT Radius	Straight TEES	CAPS	STUB ENDS			Reducer Concentric Eccentric
		Center to face (A)	Center to face (B)	Center to face (A)	Radius (A)	Center to face (A)			Diameter (G)	Long (ASA) Length (F)	Short (MSS) Length (F)	
1/2	21.34	38.1	15.9	38.1	38.1	-	25.4	25.4	34.9	76.2	50.8	50.8
3/4	26.67	28.6	11.1	28.6	28.6	-	28.6	25.4	42.8	76.2	50.8	50.8
1	33.40	38.1	22.2	38.1	38.1	25.4	38.1	38.1	50.8	101.6	50.8	50.8
1 1/4	42.16	47.6	25.4	47.6	47.6	31.8	47.6	38.1	63.5	101.6	50.8	50.8
1 1/2	48.26	57.2	28.6	57.2	57.2	38.1	57.2	38.1	73.0	101.6	50.8	63.5
2	60.32	76.2	34.9	76.2	76.2	50.8	63.5	38.1	92.0	152.4	63.5	76.2
2 1/2	73.02	95.2	44.5	95.2	95.2	63.5	76.2	38.1	104.8	152.4	63.5	88.9
3	88.90	114.0	50.8	114.0	114.0	76.2	85.7	50.8	127.0	152.4	63.5	88.9
3 1/2	101.60	133.0	57.2	133.0	133.0	88.9	95.3	63.5	139.7	152.4	76.2	-
4	114.30	152.0	63.5	152.0	152.0	101.6	104.8	63.5	157.2	152.4	76.2	101.6
5	141.30	191.0	82.6	191.0	191.0	127.0	123.8	76.2	185.7	203.2	76.2	127.0
6	168.27	228.6	95.3	228.6	228.6	152.4	142.8	88.9	215.9	203.2	88.9	140.0
8	219.07	304.8	127.0	304.8	304.8	203.2	177.8	101.6	270.0	203.2	101.6	152.0
10	273.05	381.0	159.7	381.0	381.0	254.0	215.9	127.0	324.0	254.0	127.0	178.0
12	323.85	457.2	190.5	457.2	457.2	305.0	254.0	152.4	381.0	254.0	152.4	203.0
14	355.60	533.4	222.2	533.4	533.4	356.0	280.0	165.1	412.8	305.0	152.4	330.0
16	406.40	609.6	254.0	609.6	609.6	406.0	304.8	177.8	470.0	305.0	152.4	356.0
18	457.20	685.8	285.7	685.8	685.8	457.0	343.0	203.2	533.4	305.0	152.4	381.0
20	508.00	762.0	317.6	762.0	762.0	508.0	381.0	228.6	584.2	305.0	152.4	508.0
24	609.60	914.4	381.0	914.4	914.4	610.0P	432.6	266.7	692.2	305.0	152.4	508.0

FLANGE DIMN. TO ANSI B16.5



NB Size	Outside Diameter of Flange O		Thickness Of Flange Q		Diameter of Raised Face R		Length through hub - Y			Drilling					
	in	mm	in	mm	in	mm	Welding Neck	Slip-on		Lap Joint	Diameter of Bolt Circle	No	Number and Size of holes		
								Screwed	Socket-weld						
							in	mm	in	mm	in	mm	in	mm	
1/2	3 1/2	88.9	7/16	11.1	1 3/8	34.9	1 7/8	47.6	5/8	15.9	2 3/8	60.3	4	5/8	15.9
3/4	3 7/8	98.4	1/2	12.7	1 11/16	42.9	2 1/16	52.4	5/8	15.9	2 3/4	69.8	4	5/8	15.9
1	4 1/4	107.9	9/16	14.3	2	50.8	2 3/16	55.6	11/16	17.5	3 1/8	79.4	4	5/8	15.9
1 1/4	4 5/8	117.5	5/8	15.9	2 1/2	63.5	2 1/4	57.1	13/16	20.6	3 1/2	88.9	4	5/8	15.9
1 1/2	5	127.0	11/16	17.5	2 7/8	73.0	2 7/16	61.9	7/8	22.2	3 7/8	98.4	4	5/8	15.9
2	6	152.4	3/4	19.1	3 5/8	92.1	2 1/2	63.5	1	25.4	4 3/4	120.6	4	3/4	19.0
2 1/2	7	177.8	7/8	22.2	4 1/8	104.8	2 3/4	69.8	1 1/8	28.6	5 1/2	139.7	4	3/4	19.0
3	7 1/2	190.5	15/16	23.8	5	127.0	2 3/4	69.8	1 3/16	30.2	6	152.4	4	3/4	19.0
3 1/2	8 1/2	215.9	15/16	23.8	5 1/2	139.7	2 13/16	71.4	1 1/4	31.7	7	177.8	8	3/4	19.0
4	9	228.6	15/16	23.8	6 3/16	157.2	3	76.2	1 5/16	33.3	7 1/2	190.5	8	3/4	19.0
5	10	254.0	15/16	23.8	7 5/16	185.7	3 1/2	88.9	1 7/16	36.5	8 1/2	215.9	8	7/8	22.2
6	11	279.4	1	25.4	8 1/2	215.9	3 1/2	88.9	1 9/16	39.7	9 1/2	241.3	8	7/8	22.2
8	13 1/2	342.9	1 1/8	28.6	10 5/8	269.9	4	101.6	1 3/4	44.4	11 3/4	298.4	8	7/8	22.2
10	16	406.4	1 3/16	30.2	12 3/4	323.8	4	101.6	1 15/16	49.2	14 1/4	361.9	12	1	25.4
12	19	482.6	1 1/4	31.8	15	381.0	4 1/2	114.3	2 3/16	55.6	17	431.8	12	1	25.4
14	21	533.4	1 1/8	34.9	16 1/4	412.7	5	127.0	2 1/4	57.1	18 3/4	476.2	12	1 1/8	28.6
16	23 1/2	596.9	1 7/16	36.5	18 1/2	469.9	5	127.0	2 1/2	63.5	21 1/4	539.7	16	1 1/8	28.6
18	25	635.0	1 9/16	39.7	21	533.4	5 1/2	139.7	2 11/16	68.3	22 3/4	577.8	16	1 1/4	31.7
20	27 1/2	698.5	1 11/16	42.9	23	584.2	5 11/16	144.5	2 7/8	73.0	25	635.0	20	1 1/4	31.7
22	29 1/2	749.3	1 13/16	46.0	25 1/4	641.3	5 7/8	149.2	3 1/8	79.4	27 1/4	692.1	20	1 3/8	34.9
24	32	812.8	1 7/8	47.6	27 1/4	692.1	6	152.4	3 1/4	82.5	29 1/2	749.3	20	1 3/8	34.9
26	34 1/2	869.9	2	50.8	29 1/4	742.9	5	127.0	3 3/8	85.7	31 3/4	806.4	24	1 3/8	34.9
28	36 1/2	927.1	2 1/16	52.4	31 1/4	793.7	5 11/16	128.6	3 7/16	87.3	34	863.6	28	1 3/8	34.9
30	38 3/4	984.2	2 1/8	54.0	33 3/4	857.2	5 1/8	130.2	3 1/2	88.9	36	914.4	28	1 3/8	34.9
32	41 3/4	1060.4	2 1/4	57.1	35 3/4	908.0	5 1/4	133.3	3 5/8	92.1	38 1/2	977.9	28	1 5/8	41.3
34	43 3/4	1111.2	2 5/16	58.7	37 3/4	958.8	5 5/16	134.9	3 11/16	93.7	40 1/2	1028.7	32	1 5/8	41.3
36	46	1168.4	2 3/8	60.3	40 1/4	1022.3	5 3/8	136.5	3 3/4	95.2	42 3/4	1085.8	32	1 5/8	41.3

150 lbs



REASON FOR RESUBMISSION: NO COMMENTS FROM TANGEDCO / DESEIN RECEIVED ON REV. 0 DOCUMENT. ADDITIONAL DETAILS ARE INCLUDED IN THE DOCUMENT. SUBMITTED FOR APPROVAL PLEASE.

	BHARAT HEAVY ELECTRICALS LIMITED PROJECT ENGINEERING MANAGEMENT (MECHANICAL AUXILIARY)
This approval status shall be interpreted as laid down in the contract and it shall not relieve the contractor from his contractual obligation.	
APPROVAL CATEGORY AWARDED = I	
<input checked="" type="checkbox"/> CAT I - Approved <input type="checkbox"/> CAT II - Approved with Comments as Noted <input type="checkbox"/> CAT III - Not Approved <input type="checkbox"/> CAT IV - Reference Drawing	
Name:	Signature: 
VIPIN NAUNI	

VIPIN NAUNI
Reviewed by BHEL and
found in order. Submitted
for TANGEDCO / Desein
Approval.
2018.12.31 11:55:31 +05'30'

Date	Rev	Description of Revision	ALT	CHD	APPD
PROJECT		2x660 MW ENNORE SEZ COAL BASED STPP AT ASH DYKE OF NCTPS, CHENNAI			
		CUSTOMER TAMILNADU GENERATION AND DISTRIBUTION CORPORATION LIMITED (TANGEDCO)			
		CONSULTANT DESEIN PRIVATE LIMITED DESEIN HOUSE, GREATER KAILASH-II, NEW DELHI			
		EPC CONTRACTOR BHARAT HEAVY ELECTRICALS LTD PS-PEM, PPEI-BUILDING, SECTOR-16A, PLOT NO. 25, NOIDA-201301			
JOB NO. _____					
STATUS	CONTRACT	DOC. NO: PE-V0-412-553-A034			Rev: 01
PACKAGE		AIR CONDITIONING SYSTEM			
TITLE		TDS & GAD of Expansion Tank & make up water tank			

TECHNICAL DATA SHEET OF MAKE UP WATER & EXPANSION TANK

S.No	DESCRIPTION	TECHNICAL DATA		
1	Item	Make Up water Tank	Make Up water Tank	Expansion Tank
2	Indicative Image			
3	Quantity	4	6	1
4	Type	FRP	FRP	FRP
5	Make			
6	Overall Dimension in mm (L X W X H)	1700 X1200 x 1300	2000 X 2000 x 2400	1000 X1000 x 1400
7	Capacity (CUM)	2	8	1
8	MOC	FRP Steel Reinforced	FRP Steel Reinforced	FRP Steel Reinforced
9	Thickness	7mm	7mm	7mm
10	Reference drawing	GA DRGS	GA DRGS	GA DRGS

NOTE -

1. MATERIAL OF CONSTRUCTION : 7.0 MM THICK FRP
2. QUANTITY :1 NOS. TO HALL (1 CUM CAPACITY EACH)
3. WEIGHT OF TANK WITH WATER : 1100 KGS.
4. WEIGHT OF TANK WITHOUT WATER : 100 KGS.
5. TANK SHALL BE SUPPLIED WITH NOZZLE OPENING.
6. PROJECTION OF PIPE CONNECTION FROM TANK SURFACE = 100MM (TYP.)
7. STIFFENERS/ANGLES SHALL BE PROVIDED ON THE TANK AT REQUIRED LOCATION FOR TANK STABILITY.

OTHER COMMENTS:

1. NOZZLES QTY. & SIZE ARE AS SHOWN IN THE DRAWING.
2. FOUNDATION DETAILS ARE INCLUDED IN THE COOLING TOWER LAYOUT DRAWING.
3. LOW LEVEL & HIGH LEVEL POSITION ARE AS SHOWN IN THE DRAWING.

SN.	SIZE	QTY	DESCRIPTION
01	50NB	01	NOZZLE FOR MAKE UP WATER
02	50NB	01	NOZZLE FOR QUICK FILL
03	25NB	01	NIPPLE FOR LEVEL INDICATOR
04	25NB	01	NIPPLE FOR LEVEL INDICATOR
05	32NB	01	NOZZLE FOR DRAIN WATER
06	32NB	01	NOZZLE FOR OVER FLOW
07	65NB	02	LOW LEVEL SWITCH
08	65NB	02	HI-LEVEL SWITCH
09	50NB	01	NOZZLE FOR WATER OUT
10	500NB	01	MAN HOLE

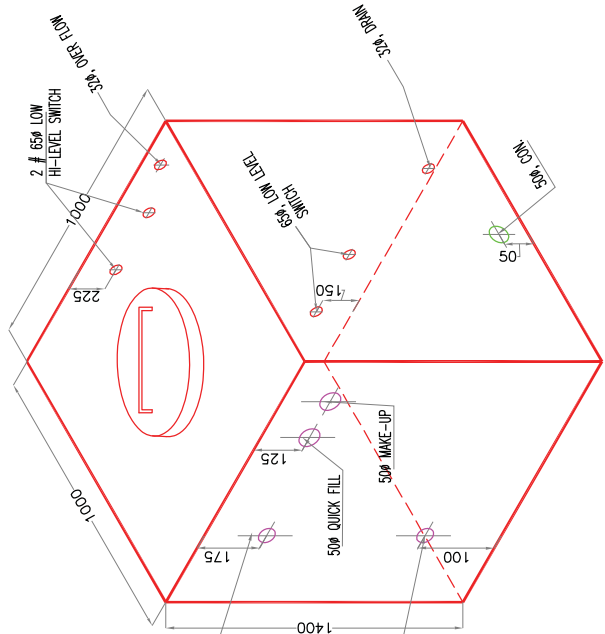

ISOMETRIC VIEW

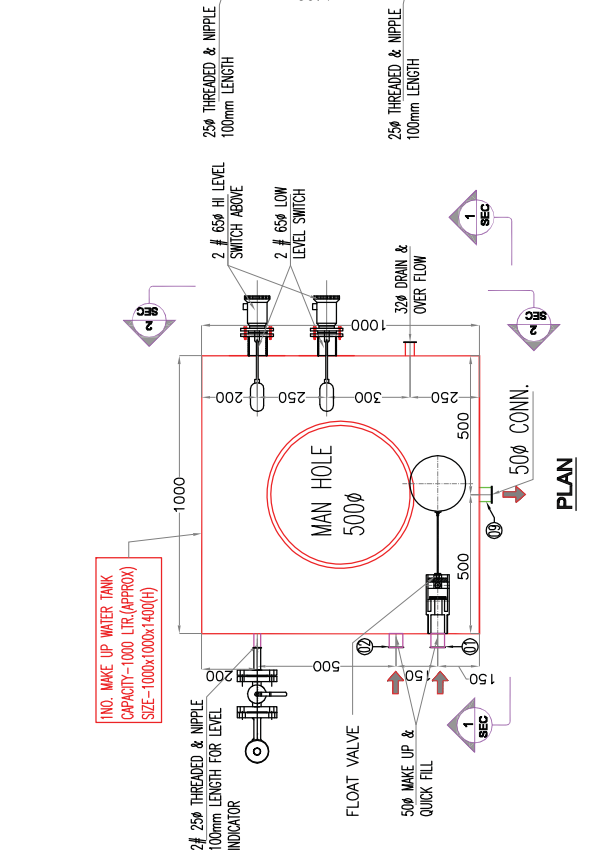

PLAN

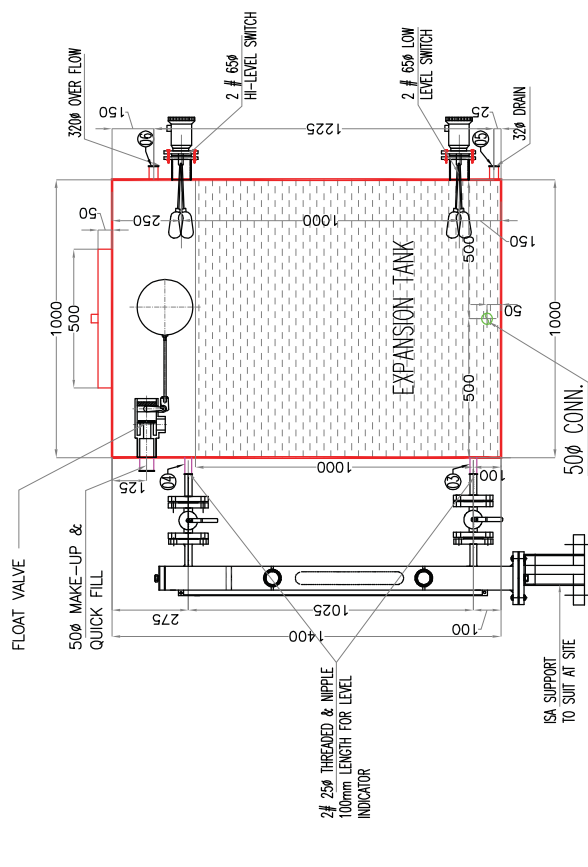

SECTION - 11

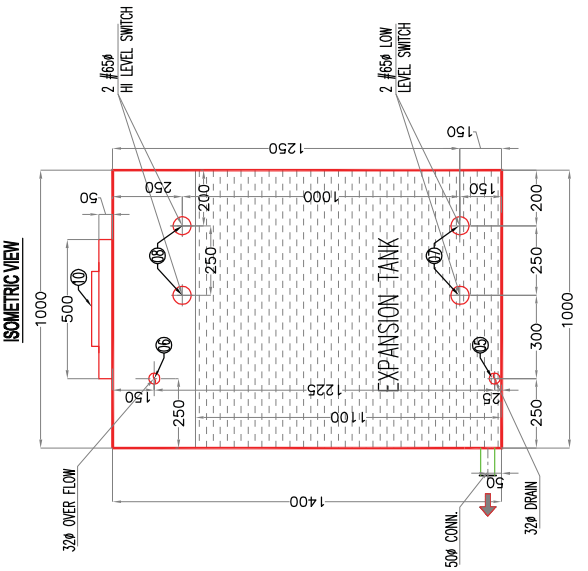

SECTION - 22

REV	REVISION DESCRIPTION	DRAWN	CHECK	DATE
REVISIONS				
	PROJECT: 2x660 MW ENMORE SEZ COAL BASED STPP AT ASH DYKE OF NCTPS, CHENNAI			
	CUSTOMER: TAMILNADU GENERATION AND DISTRIBUTION CORPORATION LIMITED (TANGEDCO)			
	CONSULTANT: DESIGN HOUSE, GREATER KALASHI-II, NEW DELHI			
	EPC CONTRACTOR: BHEL DRAWING NO. [REDACTED]			
	DRAWING TITLE: FRP STEEL REINFORCED EXPANSION WATER TANK (1 CUM) QTY.-1 NOS. (EXPANSION TANK FOR TG. BUILDING)			

NOTE -

1. MATERIAL OF CONSTRUCTION : 7.0 MM THICK FRP
2. QUANTITY -4 NOS. ESP BLDG. (2 CUM CAPACITY EACH) PER UNIT
3. WEIGHT OF TANK WITH WATER : 2150 KGS.
4. WEIGHT OF TANK WITHOUT WATER : 150 KGS.
5. TANK SHALL BE SUPPLIED WITH NOZZLE OPENING.
6. PROJECTION OF PIPE CONNECTION FROM TANK SURFACE = 100MM (TYP.)
7. PROJECTION OF SOCKET CONNECTION FROM TANK SURFACE = 60MM (TYP.)
8. STIFFENERS/ANGLES SHALL BE PROVIDED ON THE TANK AT REQUIRED LOCATION FOR TANK STABILITY.
9. 2 NOS. TANK EQUALIZER SOCKET MAKE-UP SIDE & 2 NOS. TANK EQUALIZER SOCKET OVER FLOW DRAIN SIDE

OTHER COMMENTS:

1. NOZZLES QTY. & SIZE ARE AS SHOWN IN THE DRAWING.
2. FOUNDATION DETAILS ARE INCLUDED IN THE COOLING TOWER LAYOUT DRAWING.
3. LOW LEVEL & HIGH LEVEL POSITION ARE AS SHOWN IN THE DRAWING.

NOZZLE SCHEDULE (FOR EACH TANK)		
SN.	SIZE	DESCRIPTION
01	32NB	NOZZLE FOR MAKE UP WATER
02	32NB	NOZZLE FOR QUICK FILL
03	25NB	NIPPLE FOR LEVEL INDICATOR
04	25NB	NIPPLE FOR LEVEL INDICATOR
05	32NB	NOZZLE FOR DRAIN WATER
06	32NB	NOZZLE FOR OVER FLOW
07	65NB	LOW LEVEL SWITCH
08	65NB	HI-LEVEL SWITCH
09	32NB	NOZZLE FOR WATER OUT
10	50NB	MAN HOLE
11	50NB	NOZZLE FOR EQUALIZER

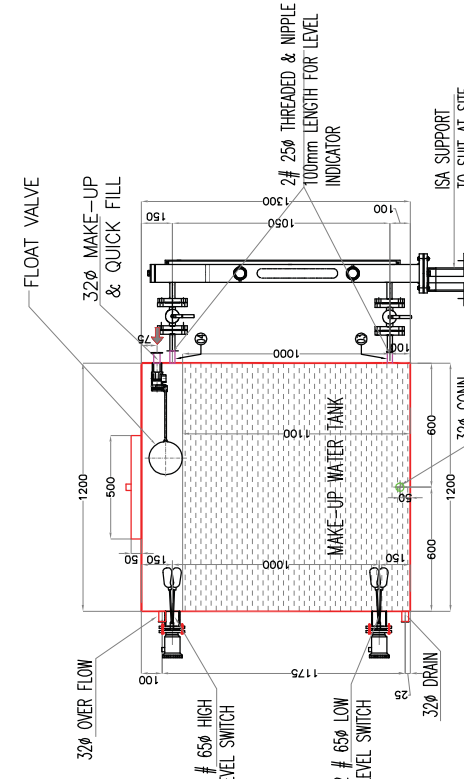
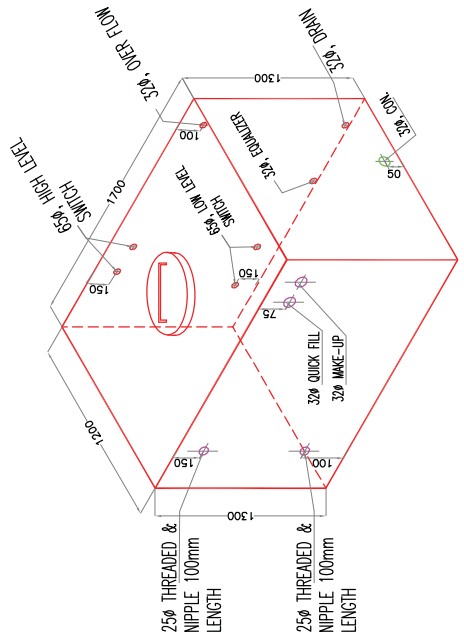
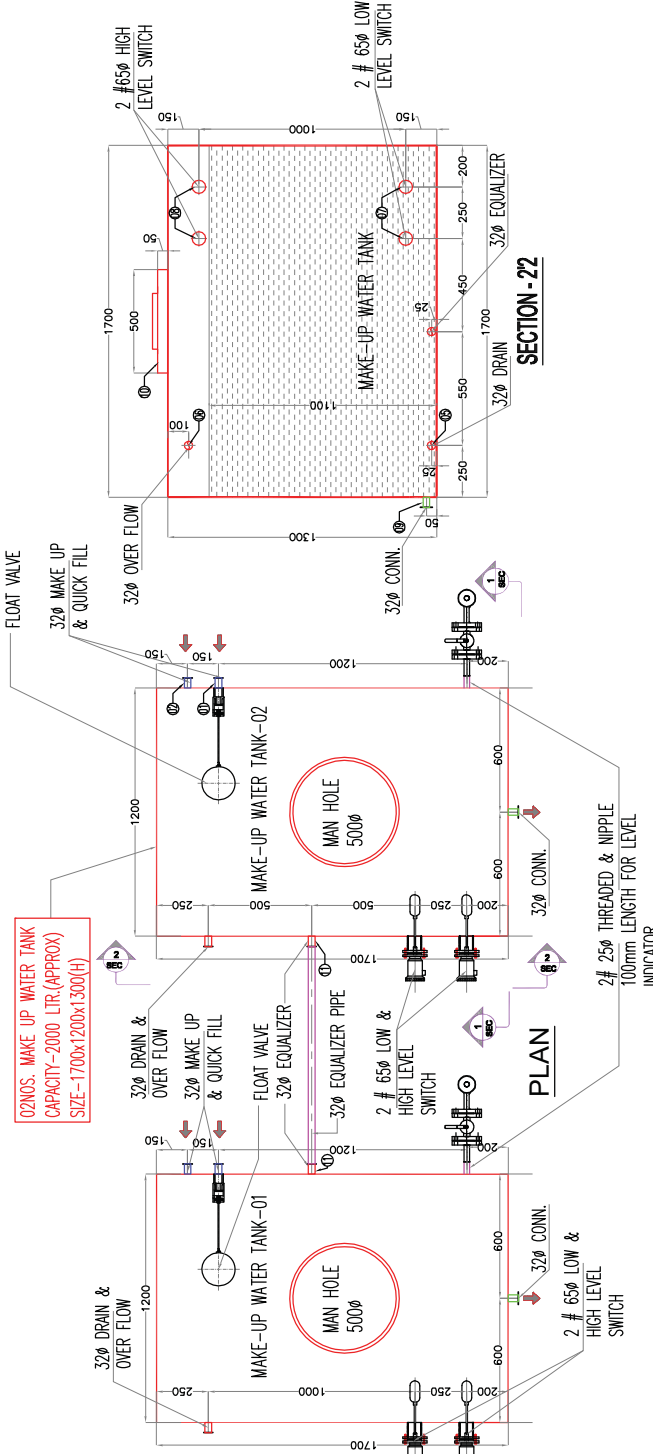

REV	REVISION DESCRIPTION	DRAWN	CHECK	DATE
REVISIONS				
	PROJECT: 2x660 MW ENMORE SEZ COAL BASED STPP AT ASH DYKE OF NCTPS, CHENNAI			
	CUSTOMER: TAMILNADU GENERATION AND DISTRIBUTION CORPORATION LIMITED (TANGEDCO)			
	CONSULTANT: DESIGN PRIVATE LIMITED DESIGN HOUSE, GREATER KALASHI-II, NEW DELHI			
	EPC CONTRACTOR: RELIANT ENERGY SERVICES LTD. PROJECT: ENMORE SEZ			
	DRAWING TITLE: FRP STEEL REINFORCED MAKE-UP WATER TANK (2 CUM) QTY. - 02			

NOTE -

1. MATERIAL OF CONSTRUCTION : 7.0 MM THICK FRP
2. QUANTITY -2 NOS. TG BLDG., 2 NOS. SERVICE BLDG., 2 NOS. ADMIN BLDG. (8 CUM CAPACITY EACH)
3. WEIGHT OF TANK WITH WATER : 8350 KGS
4. WEIGHT OF TANK WITHOUT WATER : 350 KGS
5. TANK SHALL BE SUPPLIED WITH NOZZLE OPENING.
6. PROJECTION OF PIPE CONNECTION FROM TANK SURFACE = 100MM (TYP.)
7. PROJECTION OF SOCKET CONNECTION FROM TANK SURFACE = 60MM (TYP.)
8. STIFFENERS/ANGLES SHALL BE PROVIDED ON THE TANK AT REQUIRED LOCATION FOR TANK STABILITY.
9. 3 NOS. TANK EQUALIZER SOCKET MAKE-UP SIDE & 3 NOS. TANK EQUALIZER SOCKET OVER FLOW DRAIN SIDE

OTHER COMMENTS:

1. NOZZLES QTY. & SIZE ARE AS SHOWN IN THE DRAWING.
2. FOUNDATION DETAILS ARE INCLUDED IN THE COOLING TOWER LAYOUT DRAWING.
3. LOW LEVEL & HIGH LEVEL POSITION ARE AS SHOWN IN THE DRAWING.

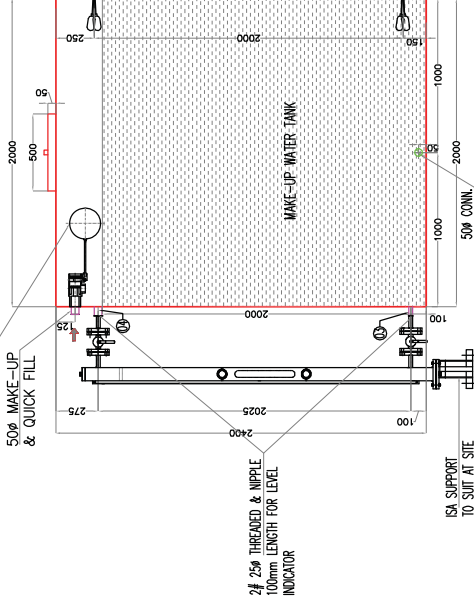
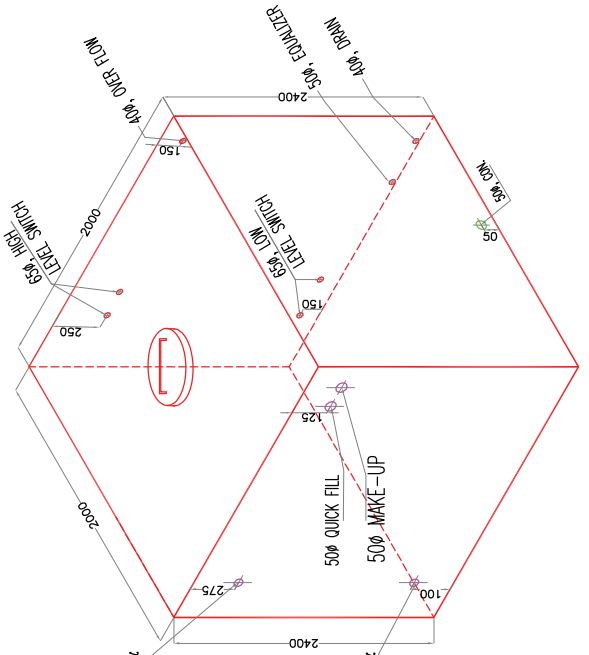
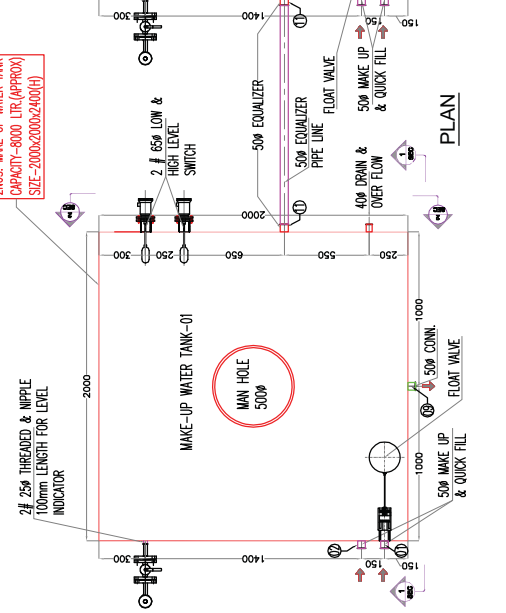
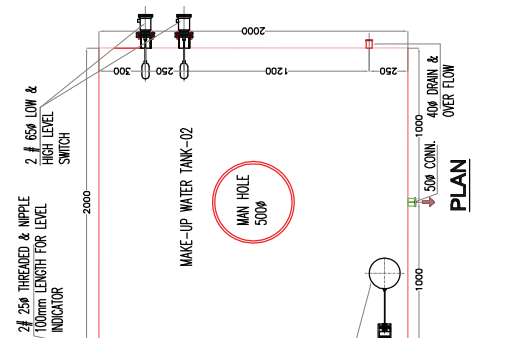
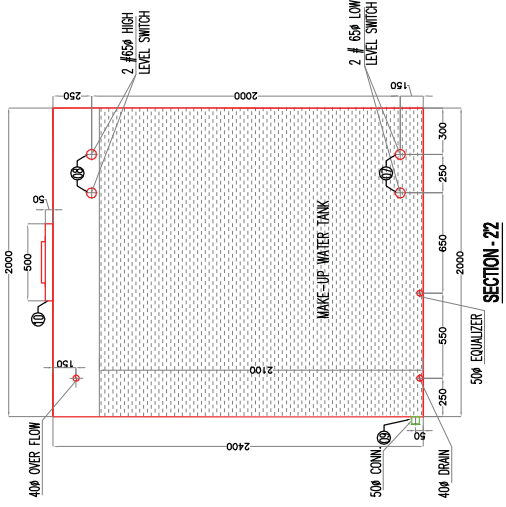

NOZZLE SCHEDULE (FOR EACH TANK)	
SN.	DESCRIPTION
01	NOZZLE FOR MAKE UP WATER
02	NOZZLE FOR QUICK FILL
03	NIPPLE FOR LEVEL INDICATOR
04	NIPPLE FOR LEVEL INDICATOR
05	NOZZLE FOR DRAIN WATER
06	NOZZLE FOR OVER FLOW
07	LOW LEVEL SWITCH
08	HI-LEVEL SWITCH
09	NOZZLE FOR WATER OUT
10	MAN HOLE
11	NOZZLE FOR EQUALIZER



REV	REVISION DESCRIPTION	DRAWN	CHECK	DATE
REVISIONS				
	2x660 MW ENRORR SEZ COAL BASED STPP AT ASH DYKE OF NCTPS, CHENNAI			
CUSTOMER	TAMILNADU GENERATION AND DISTRIBUTION CORPORATION LIMITED (TANGEDCO)			
CONSULTANT	DESIGN PRIVATE LIMITED DISIGN HOUSE, GREATER KALASHI-IL, NEW DELHI			
EPC CONTRACTOR:	BHEL DRAWING NO.			
	SHARAD RAVI SUDHAKAR ITR POWER SECTOR PROJECT MANAGERS PROJECT ENGINEER, INDIA			

DRAWING TITLE
FRP STEEL REINFORCED MAKE-UP WATER TANK (8 CUM) QTY.-02
(02 NOS MAKE-UP WATER TANKS FOR TG BUILDING)



DOCUMENT IS APPROVED VIDE TANGEDCO LETTER NO. SE/E/TH&HYP/EE-7/M/AEE/M/F.EN SEZ STPP/D.670 /18 DT.25.09.2018

	BHARAT HEAVY ELECTRICALS LIMITED PROJECT ENGINEERING MANAGEMENT (MECHANICAL AUXILIARY)
This approval status shall be interpreted as laid down in the contract and it shall not relieve the contractor from his contractual obligation.	
APPROVAL CATEGORY AWARDED = I	
<input checked="" type="checkbox"/> CAT I - Approved <input type="checkbox"/> CAT II - Approved with Comments as Noted <input type="checkbox"/> CAT III - Not Approved <input type="checkbox"/> CAT IV - Reference Drawing	
Name: VIPIN NAUNI	Signature: 

Digitally signed by VIPIN NAUNI

Reason: Reviewed by BHEL. Submitted for Desein / TANGEDCO Approval.

Date: 2018.07.17
15:34:49 +05'30'

Date	Rev	Description of Revision	ALT	CHD	APPD
PROJECT		2x660 MW ENNORE SEZ COAL BASED STPP AT ASH DYKE OF NCTPS, CHENNAI			
		CUSTOMER	TAMILNADU GENERATION AND DISTRIBUTION CORPORATION LIMITED (TANGEDCO)		
		CONSULTANT	DESEIN PRIVATE LIMITED DESEIN HOUSE, GREATER KAILASH-II, NEW DELHI		
		EPC CONTRACTOR	BHARAT HEAVY ELECTRICALS LTD PS-PEM, PPEI-BUILDING, SECTOR-16A. PLOT NO. 25. NOIDA-201301		



STATUS	CONTRACT	DOC. PE-V0-412-553-A035	Rev: 00
PACKAGE		AIR CONDITIONING SYSTEM	
TITLE		Technical Data Sheet of filters	

TECHNICAL DATA SHEET FOR FILTER



S.NO.	DESCRIPTION	SPECIFICATION
A.	PRE-FILTER	
1	Item	Pre-Filter
2	Application	Air Filtration
3	MAKE	AS PER APPROVED VENDOR LIST
4	Product Image	
5	Standard	As Per ASHRAE-52-79/EN-779
6	Type of Construction	Cassette Type/Box Type
7	Media Used	Non Woven Synthetic
8	Efficiency of Filter	Average arrestance of 65 to 80% As BS-6540 / ASHRAE-52-76
9	Filter Grade	EU-4/G-4
10	Thickness	50 MM
11	Material of Filter Frame	GI sheet (min 18 gauge) / Aluminum alloy (min. 16 gauge)
12	Media Support/Separator	Galvanized steel wire Mesh of 10MM with Handle
13	Filter Media	High Density Poly Ethylene (HDPE)
14	Standard Size	610MM x 610MM x 50MM
		610MM x 305MM x 50MM
15	Face Velocity	Not more than 2.50 m/sec (Max)
16	Pressure Drop (Initial/Final)	≤04.50 MM/≤7.5 MM
17	Mode of Cleaning of Filter	By Water Or By Detergent at Low Pressure((less than 5kg/cm ²)
18	Spaces	Suitable Aluminum Spaces shall be provided for uniform air flow
19	Sealing in casing	Casing shall be provided with Neoprene sponge rubber sealing
20	Temperature Resistance	70 Degree C
B.	FINE FILTER	
1	Item	Fine Filter
2	Application	Air Filtration
3	MAKE	AS PER APPROVED VENDOR LIST
4	Product Image	
5	Standard	As Per ASHRAE-52-79/EN-779
6	Type of Construction	Flange Type
7	Media Used	Non Woven Synthetic

8	Efficiency of Filter	Average arrestance of 80-90% As BS-6540 / ASHRAE-52-76
9	Filter Grade	EU-7/F-7
10	Thickness	305 MM
11	Material of Filter Frame	Aluminum alloy (min. 16 gauge)
12	Media Support/Separator	Heavy Corrugated Aluminum spaces
13	Filter Media	High Density Poly Ethylene (HDPE)
14	Standard Size	610MM x 610MM x 305MM
		610MM x 305MM x 305MM
15	Face Velocity	Not more than 2.4 m/sec (Max)
16	Pressure Drop (Initial/Final)	≤07.50 MM/≤18.00 MM
17	Mode of Cleaning of Filter	By Compressed Air at Low Pressure (less than 5kg/cm ²)
18	Sealing in casing	Neoprene sponge rubber sealing shall be provided on either face of filter frame
19	Temperature Resistance	70 Degree C
C.	<u>HEPA FILTER</u>	
1	Item	HEPA Filter
2	Application	Air Filtration
3	MAKE	AS PER APPROVED VENDOR LIST
4	Product Image	
5	Standard	As Per ASHRAE-52-79/EN-779
6	Type of Construction	Flange Type/Box type
7	Media Used	Micro fibre Glass paper
8	Efficiency of Filter	99.97% Down to 0.3 Micron
9	Filter Grade	EU-13/F-13
10	Thickness	305 MM
11	Material of Filter Frame	Aluminium Alloy (Min 16 Gauge) with Handle
12	Media Support/Separator	Aluminium
13	Standard Size	610MM x 610MM x 305MM
		610MM x 305MM x 305MM
14	Face Velocity	Not more than 1.2 m/sec (Max)
15	Pressure Drop (Initial/Final)	≤20.00 MM/≤60.00 MM
16	Mode of Cleaning of Filter	By Compressed Air at Low Pressure(less than 5kg/cm ²)
17	Sealing in casing	Neoprene sponge rubber sealing shall be provided on either face of filter frame
18	Temperature Resistance	70 Degree C

DOCUMENT IS APPROVED TANGEDCO LETTER NO. **CE/PR-1/SE/E/THPRO./EE2/AEE/F.BHEL/PEM/ D. 455 /19 DTD .10 .05.2019**

	BHARAT HEAVY ELECTRICALS LIMITED PROJECT ENGINEERING MANAGEMENT (MECHANICAL AUXILIARY)
This approval status shall be interpreted as laid down in the contract and it shall not relieve the contractor from his contractual obligation.	
APPROVAL CATEGORY AWARDED = I	
<input checked="" type="checkbox"/> CAT I - Approved <input type="checkbox"/> CAT II - Approved with Comments as Noted <input type="checkbox"/> CAT III - Not Approved <input type="checkbox"/> CAT IV - Reference Drawing	
Name: VIPIN NAUNI	Signature: 

VIPIN NAUNI
Revised as per TANGEDCO /
Desein Comments. Reviewed
by BHEL and found in order.
Submitted for TANGEDCO /
Desein Approval.
2019.05.07 12:53:29 +05'30'

31/10/2017	A	First Submission	Vikas	Rajvir	PC
Date	Rev	Description of Revision	ALT	CHD	APPD
PROJECT		2x660 MW ENNORE SEZ COAL BASED STPP AT ASH DYKE OF NCTPS, CHENNAI			
		CUSTOMER TAMILNADU GENERATION AND DISTRIBUTION CORPORATION LIMITED (TANGEDCO)			
		CONSULTANT DESEIN PRIVATE LIMITED DESEIN HOUSE, GREATER KAILASH-II, NEW DELHI			
		EPC CONTRACTOR BHARAT HEAVY ELECTRICALS LTD PS-PEM, PPEI-BUILDING, SECTOR-16A, PLOT NO. 25, NOIDA-201301			
STATUS	CONTRACT	DOC. NO: PE-V0-412-553-A037			Rev: 02
PACKAGE		AIR CONDITIONING SYSTEM			
TITLE		PID & AIR FLOW FOR MAIN PLANT, SERVICE, ADMIN & ESP BUILDING ETC			

