

Item Details and Technical Specifications

Sl.No	Technical Specifications	Qty
1	<p>HYD. CYLINDER ASSY. 3-M-04D03-16325</p> <p>HYD. CYLINDER ASSEMBLY DRAWING GIVEN BELOW IS ONLY FOR REFERENCE</p> <p>CYLINDER ASSEMBLY AS PER THE DRAWING NUMBER: 3-M-04D03-16325</p> <p>(1) Cylinder Inner Bore Dia: 63.5 mm/Nearest standard size, (2) Piston Rod Dia: 35 mm/Nearest standard size, (3) Stroke: 800 mm, (4) Type: Single rod and double acting, (5) Mounting: To suit the existing arrangement in the machine for its supporting operation. The cylinder is mounted in horizontal Position.</p>	2 Nos.
2	<p>SPARE SEAL KIT FOR 3-M-04D03-16325</p> <p>Seal kit for the ITEM 1 REFERENCE</p> <p>CYLINDER ASSEMBLY AS PER THE DRAWING NUMBER: 3-M-04D03-16325</p> <p>One set seal kit consists of Piston seals, Rod seals, Guide rings, O-rings, Wear strips etc., (All seals used in the supplied cylinder)</p>	Qty: 2 Set
<p>OPERATING PARAMETERS FOR ITEMS 1 and 2:</p> <p>(1) Working pressure: 100 bar, (2) Working temperature: up to 100 deg c, (3) Testing Pressure: 150 bar, (4) Working medium: Hydraulic oil (SS 68).</p> <p>GENERAL NOTE FOR CYLINDER ASSEMBLY ITEMS ONLY:</p> <p>The cylinder assembly to be tested to a pressure as specified under each item at supplier's works for a holding time of minimum 15 minutes at both ends and intermediate position for leak free sealing. The supplier should provide all the facilities for testing at suppliers work to BHEL engineer for pre-dispatch inspection.</p> <p>COMMON NOTE FOR ALL CYLINDER ITEMS:</p> <p>(1) The successful vendor should provide Cylinder drawings with bill of materials, Make, Critical dimensions, etc., to be submitted for BHEL's approval before starting manufacturing within 15 days from date of receipt of Purchase order in case of ordering. BHEL shall accord approval within 2 weeks' time. Bore Inner diameter shall be standard size suitable to seals which shall be designed by supplier and shall get necessary approval from BHEL engineers before manufacturing.</p> <p>(2) Both Rear and front end cushioning, air bleeding ports (if required), Breakaway pressure shall be included in the cylinder based on its application while quoting itself for technical evaluation.</p> <p>(3) Cylinder bore to be honed to a surface finish not less than 20 micro inches (or) Ra 0.6 to Ra 0.4, Piston rod should be hard chrome plated to 40 microns (min) and 55 HRC (min) hardness.</p> <p>(4) Latest wear resistant sealing arrangement and only standard size seals of Make Trelleborg / Merkel / Parker / Simrit Freudenberg / Hunger / Hallite / James Walker/ SKF /Equivalent acceptable.</p> <p>(5) Test certificates for hydraulic pressure testing, material, hardness and thickness of chrome plating to be submitted during Pre-dispatch inspection.</p> <p>(6) Warranty shall be provided for 12 months from the date of installation or 18 months from the date of supply, whichever is earlier.</p> <p>(7) Standard: The hydraulic cylinder to be designed in accordance with ISO 3320:2013/EQUIVALENT. Fluid power systems and components - Cylinder bores and piston rod diameters and area ratios - Metric series or latest revision. Unless otherwise specified in this specification. Bidder to Specify.</p>		

(8) Materials for construction for all the components are as follows (OR ITS EQUIVALENT ACCEPTABLE TO BHEL ENGINEERS)

CYLINDER TUBE (SEAMLESS) : ST52-W/EN 8/EN 24

PISTON ROD OR RAM : EN 8/ EN 24

PISTON : EN 8

LOCK NUT : EN 24

TIE RODS /PINS : EN 24

END COVERS/FLANGES : EN 8/EN 24

FASTENERS HIGH TENSILE GRADE: 10.9/12.8

SEALS : PU/PTFE/VITON OR ITS COMBINATION IN THE Makes as per Sl.No: 4

(9) Supplier may visit the site to get acquaintance about the machine and its operation before quoting.

(10) All formed threads shall be ensured with standard GO and NO GO gauges, Ring gauges so as to match in the existing arrangement in machine (if required). The same has to be ensured by the supplier in pre dispatch inspection.

(11) Point by point confirmation is required for technical evaluation.

(12) Delivery period shall be 134 days (Inclusive of duration required by BHEL for according approval of drawings & documents and for Pre-dispatch inspection).

(13) Offer shall be submitted in Two Part bid system.

ALL DIMENSIONS ARE IN MILLIMETRES

3-M-04D03-16325

DRAWING NO:

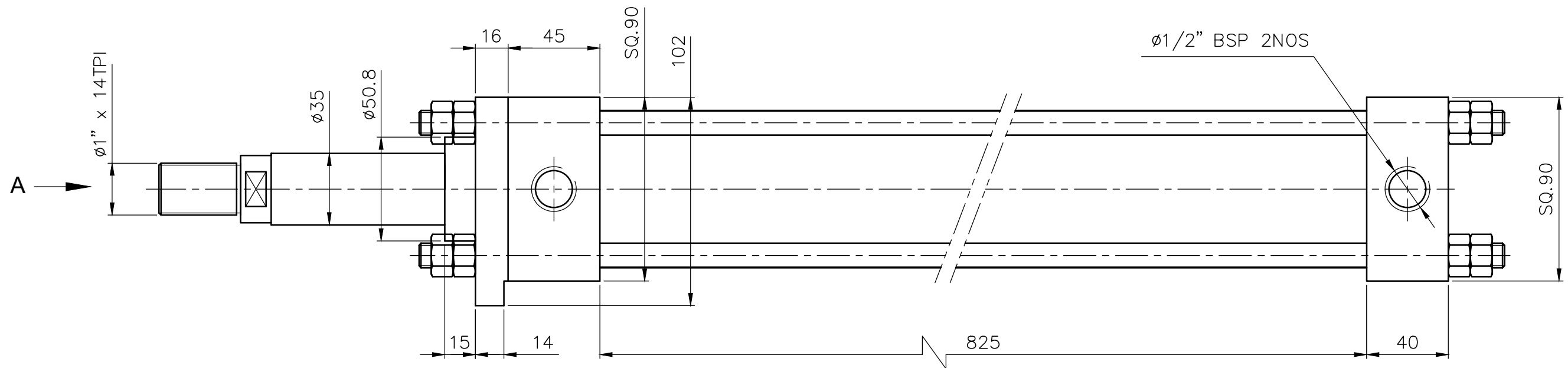

M12 / TIE ROD / 4NOS.

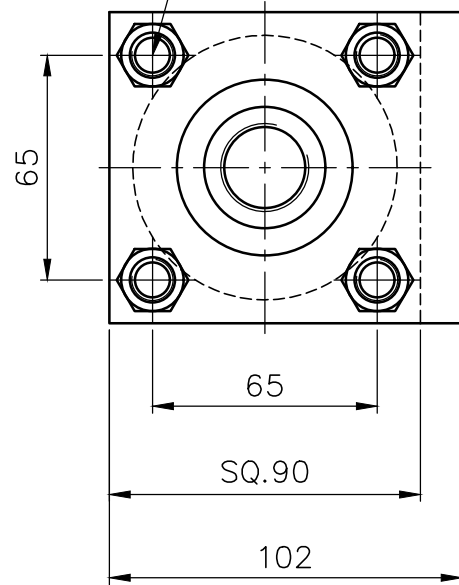

VIEW - A

CYLINDER SPECIFICATION	
CYLINDER BORE	ø63.5
CYLINDER OUTER DIA	ø76.2
PISTON ROD	ø35
STORKE	800

FOR TENDERING PURPOSE ONLY

REV	DATE	ALTERED
		CHECKED
		APPROVED
ZONE		

CAUTION: THE INFORMATION ON THIS DOCUMENT IS THE PROPERTY OF BHARAT HEAVY ELECTRICALS LIMITED. IT MUST NOT BE USED DIRECTLY OR INDIRECTLY IN ANY WAY DETRIMENTAL TO THE INTEREST OF THE COMPANY.

ITEM NO	DESCRIPTION	DRAWING NO	MATL CODE	UNIT WT
			MATL SPEC	QTY
EQPT: NC DEEP HOLE DRILLING MACHINE - AVEY				
Bharat Heavy Electricals Ltd HIGH PRESSURE BOILER PLANT TIRUCHIRAPALLI - 620014		DRN	NAME	SIGNATURE
		CHD	N.MADURAVEERAN	<i>N. maduraveeran</i>
		APPD	A.DANASEKAR	<i>A. Danasekar</i>
DEPT	GRADE OF UNTOL. DIM	SCALE	WEIGHT (Kg)	REF TO ASSY DWG NO
M&S	φ/M/£	1:2	-	-
CODE	IS: 2102			REF TO OLD DWG NO
2597				-
TITLE			CARD CODE	REV
HYDRAULIC CYLINDER			U 01	00
(CHIP BOX)			DRAWING NO :	
			3-M-04D03-16325	

Annexure B

Pre-Qualification Criteria, Vendor Confirmation to Technical Specifications

A. Pre-Qualification Criteria		
SL. No	Pre-Qualification Criteria	Vendor's Confirmation /Acceptance
	Only those vendors who satisfy the following conditions will get qualified to participate in the tender. Offers of vendors not meeting the PQR will not be considered.	
1.	Previous PO details for supplying similar kind of hydraulic cylinder items should be submitted along with offer. Otherwise offer will be rejected.	
2.	BHEL reserves the right to visit the vendor's works for verifying the manufacturing facilities and any other credential furnished by the vendor. In case the information furnished with the offers found to be false /incorrect, the offer shall be rejected.	
B. Technical Specifications		
SL. No	Description and Technical Specification of the item	Vendor's Confirmation/Acceptance
1	<p>HYD. CYLINDER ASSY. 3-M-04D03-16325</p> <p>HYD. CYLINDER ASSEMBLY DRAWING GIVEN BELOW IS ONLY FOR REFERENCE</p> <p>CYLINDER ASSEMBLY AS PER THE DRAWING NUMBER: 3-M-04D03-16325</p> <p>(1) Cylinder Inner Bore Dia: 63.5 mm/Nearest standard size, (2) Piston Rod Dia: 35 mm/Nearest standard size, (3) Stroke: 800 mm, (4) Type: Single rod and double acting, (5) Mounting: To suit the existing arrangement in the machine for its supporting operation. The cylinder is mounted in horizontal Position.</p>	Qty: 2 Nos.
2	<p>SPARE SEAL KIT FOR 3-M-04D03-16325</p> <p>Seal kit for the ITEM 1 REFERENCE</p> <p>CYLINDER ASSEMBLY AS PER THE DRAWING NUMBER: 3-M-04D03-16325</p> <p>One set seal kit consists of Piston seals, Rod seals, Guide rings, O-rings, Wear strips etc., (All seals used in the supplied cylinder)</p>	Qty: 2 Set
	<p>OPERATING PARAMETERS FOR ITEMS 1 and 2:</p> <p>(1) Working pressure: 100 bar, (2) Working temperature: up to 100 deg c, (3) Testing Pressure: 150 bar, (4) Working medium: Hydraulic oil (SS 68).</p> <p>GENERAL NOTE FOR CYLINDER ASSEMBLY ITEMS ONLY:</p> <p>The cylinder assembly to be tested to a pressure as specified under each item at supplier's works for a holding time of minimum 15 minutes at both ends and intermediate position for leak free sealing. The supplier should provide all the facilities for testing at suppliers work to BHEL engineer for pre-dispatch inspection.</p> <p>COMMON NOTE FOR ALL CYLINDER ITEMS:</p> <p>(1) The successful vendor should provide Cylinder drawings with bill of materials, Make, Critical dimensions, etc., to be submitted for BHEL's approval before starting manufacturing within 15 days from date of receipt of Purchase order in case of ordering.</p>	

BHEL shall accord approval within 2 weeks' time. Bore Inner diameter shall be standard size suitable to seals which shall be designed by supplier and shall get necessary approval from BHEL engineers before manufacturing.

(2) Both Rear and front end cushioning, air bleeding ports (if required), Breakaway pressure shall be included in the cylinder based on its application while quoting itself for technical evaluation.

(3) Cylinder bore to be honed to a surface finish not less than 20 micro inches (or) Ra 0.6 to Ra 0.4, Piston rod should be hard chrome plated to 40 microns (min) and 55 HRC (min) hardness.

(4) Latest wear resistant sealing arrangement and only standard size seals of Make Trelleborg / Merkel / Parker / Simrit Freudenberg / Hunger / Hallite / James Walker/ SKF /Equivalent acceptable.

(5) Test certificates for hydraulic pressure testing, material, hardness and thickness of chrome plating to be submitted during Pre-dispatch inspection.

(6) Warranty shall be provided for 12 months from the date of installation or 18 months from the date of supply, whichever is earlier.

(7) Standard: The hydraulic cylinder to be designed in accordance with ISO 3320:2013/EQUIVALENT. Fluid power systems and components - Cylinder bores and piston rod diameters and area ratios - Metric series or latest revision. Unless otherwise specified in this specification. Bidder to Specify.

(8) Materials for construction for all the components are as follows (OR ITS EQUIVALENT ACCEPTABLE TO BHEL ENGINEERS)
CYLINDER TUBE (SEAMLESS) : ST52-W/EN 8/EN 24
PISTON ROD OR RAM : EN 8/ EN 24
PISTON : EN 8
LOCK NUT : EN 24
TIE RODS /PINS : EN 24
END COVERS/FLANGES : EN 8/EN 24
FASTENERS HIGH TENSILE GRADE: 10.9/12.8
SEALS : PU/PTFE/VITON OR ITS COMBINATION IN THE Makes as per Sl.No: 4

(9) Supplier may visit the site to get acquaintance about the machine and its operation before quoting.

(10) All formed threads shall be ensured with standard GO and NO GO gauges, Ring gauges so as to match in the existing arrangement in machine (if required). The same has to be ensured by the supplier in pre dispatch inspection.

(11) Point by point confirmation is required for technical evaluation.

(12) Delivery period shall be 134 days (Inclusive of duration required by BHEL for according approval of drawings & documents and for Pre-dispatch inspection).

(13) Offer shall be submitted in Two Part bid system.

Supplier's Signature & Seal

Annexure – A- Additional Terms and Conditions for GeM Enquiry

The terms and condition mentioned in this document are applicable in addition to the GeM General Terms and Conditions. Bidders shall furnish pointwise confirmation/details.

Description of the Equipment:		Hydraulic cylinder and Seal kit
BHEL Tender No. & Date		
<i>To be filled by bidder</i>		
Name of the firm (Bidder)		:
Address		:
Contact details		<u>Contact person 1</u> Name: Designation: Office Phone: Mobile: e-mail: <u>Contact person 2</u> Name: Designation: Office Phone: Mobile: e-mail:
Offer reference with date		:
Sl. No	Terms and conditions	Vendor's confirmation
1.	Technical: Supply of Hydraulic cylinder and Seal kit shall be as per technical Specifications attached with the enquiry. Bidder shall comply the technical specification as per the enquiry. Any clarifications/deviations to the specification requirements are to be clearly indicated in the above format. Hidden deviations indicated elsewhere in the offer will not be evaluated.	
2.	Pre-qualification requirement: Offer shall be considered only if bidder is meeting Tender Prequalification requirement (Annexure-B). Vendor to comply with Pre-Qualification requirement of the tender and submit along with their technical bid - the credentials and other documents as indicated in the PQR in the format prescribed. Otherwise their offer will get rejected.	
3.	Inspection by BHEL/as per Technical specification(if any).	
4.	Vendor offers will be considered for price bid opening subject to fulfilment of techno commercial suitability.	
5.	Evaluation of tender will be Package wise.	
6.	Payment terms: <ol style="list-style-type: none"> 1. Payment terms for Micro & Small Enterprises (MSEs): Within 45 days after CRAC. To entitle the above payment terms, the supplier should be manufacturer of the offered item and should upload UDYAM Registration Certificate in proof of MSE. 2. Payment terms for Medium Enterprises: Within 60 days after CRAC. To entitle the above payment terms, the supplier should be manufacturer of the offered item and should upload UDYAM Registration Certificate in proof of Medium Enterprises. 3. Payment terms for Non MSME Suppliers: Within 90 days after CRAC 	

	<p>4. Dealers/Traders (if the quoted items are not manufactured by the supplier) shall be considered as Non-MSME supplier for this tender.</p> <p>Payment shall be as per above terms. This a mandatory deemed accepted clause if you are submitted your offer through GeM. Any deviation in this clause anywhere in the offer will be ignored. In case of Auto PRC/CRAC, Payment due date shall be calculated from CRAC date or material acceptance date by BHEL whichever is later.</p>	
7.	<p>Firm Price: The quoted / finalised rates shall be Firm till execution of the supplies. Offer with PVC clause will not be considered.</p>	
8.	<p>Liquidated Damages: LD terms shall be as per GeM General Terms and Conditions. Invoice date/Bill of Lading date/Airway Bill date/Lorry way bill date/e-waybill/Railway Receipt date, whichever is later will be considered for LD calculation.</p>	
9.	<p>Delivery term: The quote shall be on FOR BHEL Trichy destination basis inclusive of Packing, forwarding, Freight also to yours account. Transit Insurance is under Supplier scope.</p>	
10.	<p>Performance Bank Guarantee: Not Applicable</p>	
11.	<p>Repair & replacements: Within the guarantee period vendor has to replace / rectify the defective/ damaged items on free of cost within a reasonable time of reporting from our end.</p>	
12.	<p>Kindly Indicate the HSN Code for all items</p>	
13.	<p>Rate quoted in GeM portal should be on FOR destination basis inclusive of all taxes, freight etc. Transit Insurance is under Supplier scope.</p> <p>Please indicate the applicable GST %, P & F and freight cost (in % of material cost), which is included in your quoted rate in GeM portal.</p>	
14.	<p>Documents are to be submitted along with technical bid (Part-1)</p> <ol style="list-style-type: none"> 01. Covering letter 02. Unpriced offer. 03. Filled up and signed technical specification (GeM catalogue). 04. Filled BHEL Terms and condition sheet (Annexure-A). 05. Filled Annexure-B - PQR along with supporting documents. 06. Documents required along with offer as per technical specification 07. Catalogues. 08. MSE UDYAM Certificate (if applicable). <p>Note: All the pages of documents are to be signed and sealed by authorized signatory of the company. Any query during enquiry stage shall be replied within three days failing which offer may be rejected as non-responsive.</p>	
15.	<p>Inspection and testing requirements: Inspection and testing requirements are to be carried out as per the specification and BHEL Technical specifications in the enquiry. All test certificates are to be submitted while supply. If required by BHEL, test</p>	

	certificates to be produced before supply.	
16.	Response to Tenders for Indigenous supplier will be entertained only if the vendor has a valid GST registration Number (GSTIN) which should be clearly mentioned in the offer. If the dealer is exempted from GST registration, a declaration with due supporting documents need to be furnished for considering the offer. Dealers under composition scheme should declare that he is a composition dealer supported by the screen shot taken from GSTN portal. The dealer has to submit necessary documents if there is any change in status under GST.	
17.	Supplier shall mention their GSTIN in all their invoices (incl. credit Notes, Debit Notes) and invoices shall be in the format as specified/prescribed under GST laws. Invoices shall necessarily contain Invoice number (in case of multiple numbering system is being followed for billing like SAP invoice no, commercial invoice no etc., then the Invoice No. which is linked/uploaded in GSTN network shall be clearly indicated), Billed to party (with GSTIN) & Shipped to party details, item description as per PO, Quantity, Rate, Value, applicable taxes with nomenclature (like IGST, SGST, CGST & UTGST) separately, HSN/ SAC Code, Place of Supply etc. Wherever E-Invoice is applicable, the tax invoice/ CN / DN submitted by the vendor must contain the QR code generated in E-Invoice Portal & IRN.	
18.	All invoices shall bear the HSN Code for each item separately (Harmonized System of Nomenclature)/ SAC code (Services Accounting Code).	
19.	Invoices will be processed only upon completion of statutory requirement and further subject to following: <ul style="list-style-type: none"> • Vendor declaring such invoice in their GSTR-1 Return/ IFF • Receipt of Goods or Services and Tax invoice by BHEL. 	
20.	As the continuous uploading of tax invoices in GSTN portal (in GSTR-1/ IFF) is available for all (i.e. both Small & Large) tax payers, all invoices raised on BHEL may be uploaded immediately in GST portal on dispatch of material /rendering of services. The supplier shall ensure availability of Invoice in GSTN portal before submission of invoice to BHEL. Invoices will be admitted by BHEL only if the invoices are available in GSTN portal (in BHEL's GSTR-2A/ GSTR-2B).	
21.	In case of discrepancy in the data uploaded by the supplier in the GSTN portal or in case of any shortages or rejection in the supply, then BHEL will not be able to avail the tax credit and will notify the supplier of the same. Supplier has to rectify the data discrepancy in the GSTN portal or issue credit note or debit note (details also to be uploaded in GSTN portal) for the shortages or rejections in the supplies or additional claims, within the calendar month informed by BHEL.	
22.	In cases where invoice details have been uploaded by the vendor but failed to remit the GST amount to GST Department (Form PMT-08 or Form GST RET-01 to be submitted) within stipulated time, then GST paid on the invoices pertaining to the month for which GST return not filed by the vendor will be recovered from the vendor along with the applicable interest (currently 24% p.a) and all subsequent bills of the vendor will not be processed till filing of the GST return by the vendor	
23.	In case GST credit is denied to BHEL due to non-receipt or delayed receipt of goods and/ or tax invoice or expiry of timeline prescribed in GST law for availing such ITC, or any other reasons not attributable to BHEL, GST amount claimed in the invoice shall be disallowed to the vendor.	

24.	Where any GST liability arising on BHEL under Reverse Charge (RCM), the vendor has to submit the invoices to BHEL well within the timeline prescribed in GST Law, to enable BHEL to discharge the GST liability. If there is a delay in submission of invoice by the vendor resulting in delayed payment of GST by BHEL along with Interest, then such Interest payable or paid shall be recovered from the vendor.	
25.	GST TDS will be deducted as per Section 51 of CGST Act 2017 and in line with Notification 50/2018 –Central Tax dated 13.09.2018. GST TDS certificate will be generated in GSTN portal subsequent to vendor accepting the TDS deduction in the GSTN portal & the vendor can directly download the Certificate from the GSTN Portal.	
26.	As per the provisions of Section 194Q of the Income Tax Act, we BHARAT HEAVY ELECTRICALS LIMITED, HPBP, TRICHY having PAN AAACB4146P, had turnover in the preceding financial year for more than Rs 10 Crores. Hence, we are liable as buyer to deduct tax at source on the payment for invoices issued by Supplier on or after 1st July 2021. Accordingly, discontinue charging TCS u/s 206C(1H) on invoices issued from 1st Jul 2021 onward. We shall deduct the eligible TDS u/s 194Q on the payments for invoices issued on or after 1st Jul 2021. TDS deducted so, shall be deposited to the Income Tax Department, and TDS certificate to this effect. Tax credit of such TDS shall reflect in FORM26AS of the supplier at the end of same quarter in which TDS is deducted.	
27.	GST CREDIT: Suppliers are advised to get registered to GSTN portal. Tenderer under "GST credit" shall be preferred.	
28.	BILL PROCESSING METHOD: Supplier has to ensure the full quantity of material delivery within given PO delivery date to process the bill for payment. In case supplier fails to deliver full quantity within delivery date, bills received after PO delivery date will be processed after final despatch of the total pending supply. Further, bills will be clubbed and forwarded for payment processing as a single bunch.	
29.	MSE VENDOR: <i>Udyam Registration certificate shall be submitted by MSE vendors for availing the benefits.</i>	
30.	Fraud Prevention Policy Bidder along with its associate /collaborators /sub-contractors /sub-vendors / consultants / service providers shall strictly adhere to BHEL Fraud Prevention Policy displayed on BHEL website http://www.bhel.com and shall immediately bring to the notice of BHEL Management about any fraud or suspected fraud as soon as it comes to their notice.	
31.	Risk purchase clause: a. In the event of any successful Tenderer's failure to fulfil any of the tender / Contract obligations including supply of whole or any part of the ordered items as per Contract / Agreement, BHEL has the right to terminate the contract and purchase from elsewhere, at the risk and cost of the defaulted supplier, either the whole of the goods or any part which the supplier has failed to deliver or dispatch within the time stipulated in the contract or if the same were not	

	<p>available, the best and nearest available substitute thereof. The supplier shall be liable for the additional expenditure/difference in Cost, if any, including consequential losses which BHEL may sustain by reason of risk purchase in addition to the applicable LD as per the Purchase order/contract.</p> <p>b) The decision of BHEL with regard to the additional expenditure / difference in cost and consequential losses incurred by BHEL shall be final and binding on the supplier.</p> <p>c) The amount recoverable under risk purchase shall be recovered from the defaulted supplier in all or any of the following manners:</p> <ol style="list-style-type: none"> i. from dues available in the form of Bills payable to defaulted supplier, SD, BGs against the same contract. ii. from the dues payable to defaulted supplier against other contracts in the same Region/Unit /any other region/unit iii. In-case recoveries are not possible with any of the above available options, Legal action shall be initiated for recovery against defaulted supplier. 	
32.	<p><u>Suspension of Business Dealings:</u></p> <p>The offers of the bidders who are under suspension and also the offers of the bidders, who engage the services of the banned firms, shall be rejected. The list of banned firms is available on BHEL web site www.bhel.com.</p> <p>If any bidder/ supplier/ contractor during pre-tendering/ tendering/ post tendering/ award/ execution/ post-execution stage indulges in mal-practices, cheating, bribery, fraud or and other misconduct or formation of cartel so as to influence the bidding process or influence the price or acts or omits in any manner which tantamount to an offence punishable under any provision of the Indian Penal Code, 1860 or any other law in force in India, or does anything which is actionable under the Guidelines for Suspension of Business dealings, action may be taken against such bidder/ supplier/ contractor as per extant guidelines of the company available on www.bhel.com and/or under applicable legal provisions.</p> <p>Abridged version of extant ‘Guidelines for suspension of business dealings with suppliers/ contractors’ has now been uploaded on www.bhel.com on “supplier registration page” at the following link:</p> <p>http://www.bhel.com/vender_registration/vender.php (Guidelines for suspension of business dealings with suppliers/ contractors).</p>	
33.	<p><u>Set off :</u> BHEL shall have the right to recover any money which in the sole opinion of BHEL is due from the supplier from any money due to the supplier under this Contract or any other contract or from the Security Deposit/BG furnished by the supplier under this Contract or any other contract.</p>	
34.	<p><u>Cartel Formation:</u></p> <p>The Bidder declares that they will not enter into any illegal or undisclosed agreement or understanding, whether formal or informal with other Bidder(s). This applies in particular to prices, specifications, certifications, subsidiary contracts, submission or non-submission of bids or any other actions to restrict competitiveness or to introduce cartelization in the bidding process. In case, the Bidder is found having indulged in above activities, suitable action shall be taken by BHEL as</p>	

	per extant policies/ guidelines.	
35.	The following documents are to be sent along with consignment to store: One Duplicate for Transporter copy of tax invoice + one extra copy of tax invoice + Delivery challan + LR COPY+E-Way bill + Test certificates (if applicable).	
36.	Seller Tax invoice, LR copy, E-Way bill, Courier docket etc. are to be uploaded in GeM portal while updating dispatch details in GeM portal	
37.	Seller Tax invoices (Original for Recipient + Duplicate for Transporter) either in Original hard copies or Digitally Signed Soft copies along with copy of LR + E-Way bill are to be sent to the buyer	
	<p>Note:</p> <ol style="list-style-type: none"> 1. In the event of our customer order covering this tender being cancelled /placed on hold / otherwise modified, BHEL would be constrained to accordingly cancel / hold / modify the tender at any stage of execution. 2. BHEL may negotiate the L1 rate, if not meeting our budget / estimated cost. BHEL may re-float the tender opened, if L1 price is not acceptable to BHEL. 3. BHEL reserves its right to reject an offer due to unsatisfactory past performance by the respective Vendor in the execution of any contract to any BHEL project / Unit. 4. Any other commercial Terms indicated by the vendor in their offer elsewhere will be ignored. BHEL will proceed with tender evaluation as per Annexure-A and GeM general terms and conditions only. 	