

Technical Specifications

Sl.No	Item Description and Technical Specifications	Qty	Vendor's Confirmation /Acceptance
1	<p>Supply and Installation of Suction Blower Inlet ducts.</p> <p>1 Set contains: Suction Blower Inlet ducts As per drawing No : 3-M-19A25-16455 - 2 Nos and As per drawing No : 3-M-19A25-16456 - 2 Nos.</p>	1 Set	
<p>Scope:</p> <p>Supply and Installation of Painting Booth Suction Blower Inlet ducts in Bldg-6 at BHEL-Trichy.</p> <p>1)The supply and installation of Suction Blower Inlet ducts as per drawing Nos: 3-M-19A25-16455---- 2 Nos and 3-M-19A25-16456---- 2 Nos</p> <p>2)The Vendor shall dismantle the existing ducts (4 Nos) in the suction blowers of painting booth and install the newly fabricated ducts.</p> <p>3) All the tools, tackles and fasteners required to execute the above work is vendors scope.</p> <p>4) Required drilling machine (to make holes in the duct flanges) and crane facilities will be provided by BHEL at Free of cost.</p> <p>5) The Vendor may visit BHEL works for better understanding before submitting the offer.</p>			

Supplier's Signature & Seal

3-M-19A25-16455

DRAWING NO:

ALL DIMENSIONS ARE IN MILLIMETRES

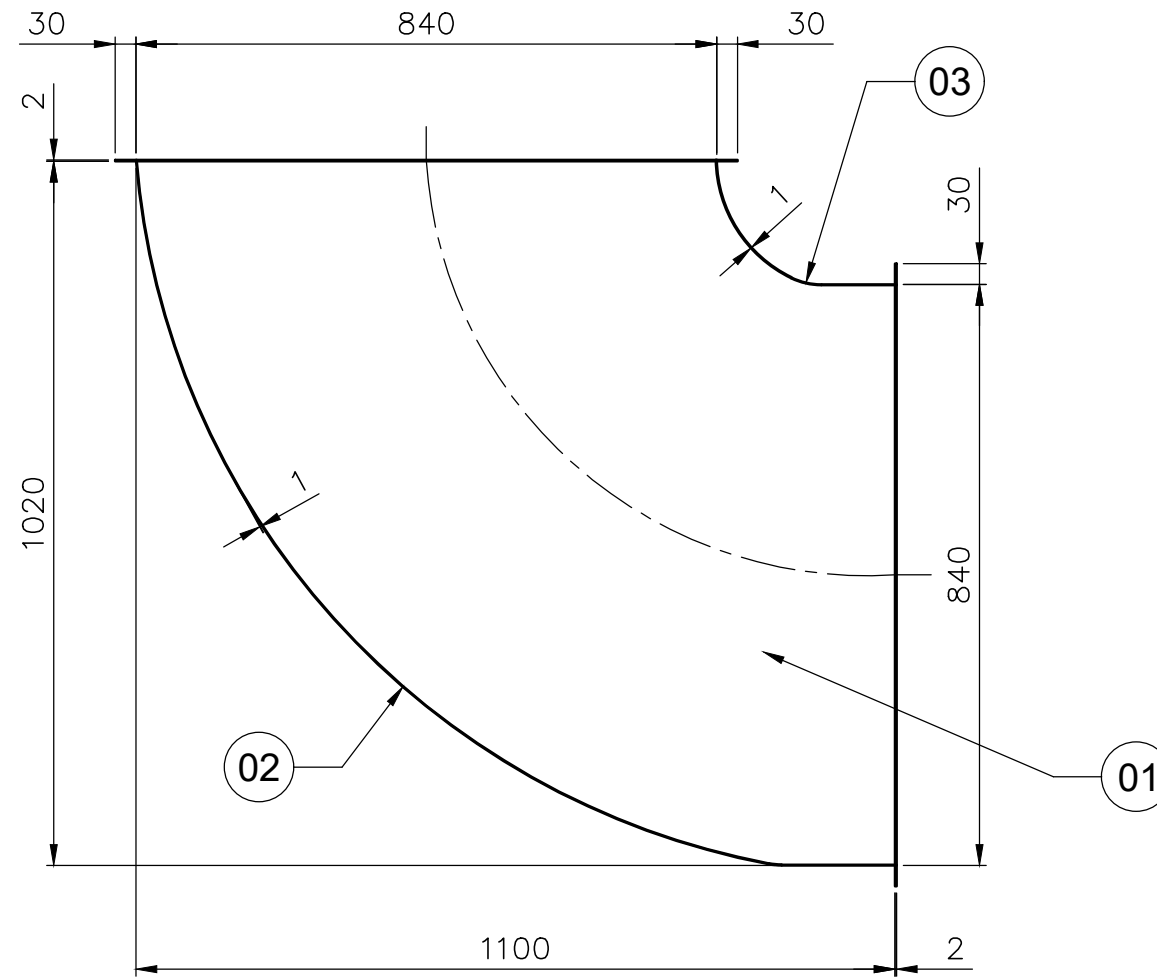
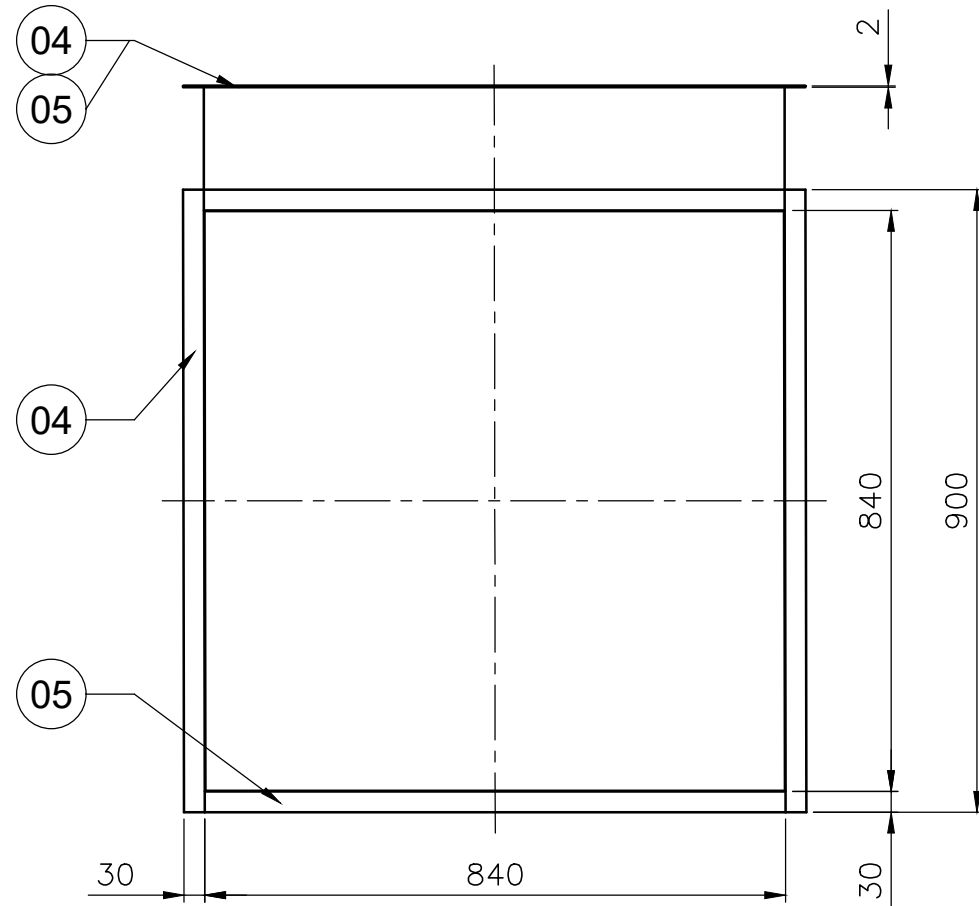

NOTE:
01. SHARP EDGES TO BE REMOVED.
02. FLANGE MATTING HOLE PROVIDED AT SITE

05	PL 5t x 30 x 840	—	IS 6911	1.00
			STAINLESS STEEL 304	4
04	PL 5t x 30 x 900	—	IS 6911	1.10
			STAINLESS STEEL 304	4
03	St 1t x 365 x 840	—	IS 6911	2.43
			STAINLESS STEEL 304	1
02	St 1t x 840 x 1100	—	IS 6911	11.02
			STAINLESS STEEL 304	1
01	St 1t x 1020 x 1100	—	IS 6911	6.58
			STAINLESS STEEL 304	2

CAUTION: THE INFORMATION ON THIS DOCUMENT IS THE PROPERTY OF BHARAT HEAVY ELECTRICALS LIMITED. IT MUST NOT BE USED DIRECTLY OR INDIRECTLY IN ANY WAY DETRIMENTAL TO THE INTEREST OF THE COMPANY.

ITEM NO	DESCRIPTION	DRAWING NO	MATL CODE	UNIT WT
			MATL SPEC	QTY
EQPT: WATER WASH SPARY PAINTING BOOTH / RSK				
DEPT M&S CODE 2597	GRADE OF UNTOL. DIM φ/M/∅ IS: 2102	SCALE 1:10	WEIGHT (Kg) 35.00	NAME N.MADURAVEERAN
				SIGNATURE <i>N. Maduraveeran</i>
				DATE 18.12.23
TITLE DUCT - 01 840x1020x1100 (SUCTION BLOWER INLET)		CARD CODE U 01	DRAWING NO : 3-M-19A25-16455	
REV			REF TO ASSY DWG NO	ITEM
DATE			REF TO OLD DWG NO	00
ALTERED				
CHECKED				
APPROVED				
ZONE				

ALL DIMENSIONS ARE IN MILLIMETRES

3-M-19A25-16456

DRAWING NO:

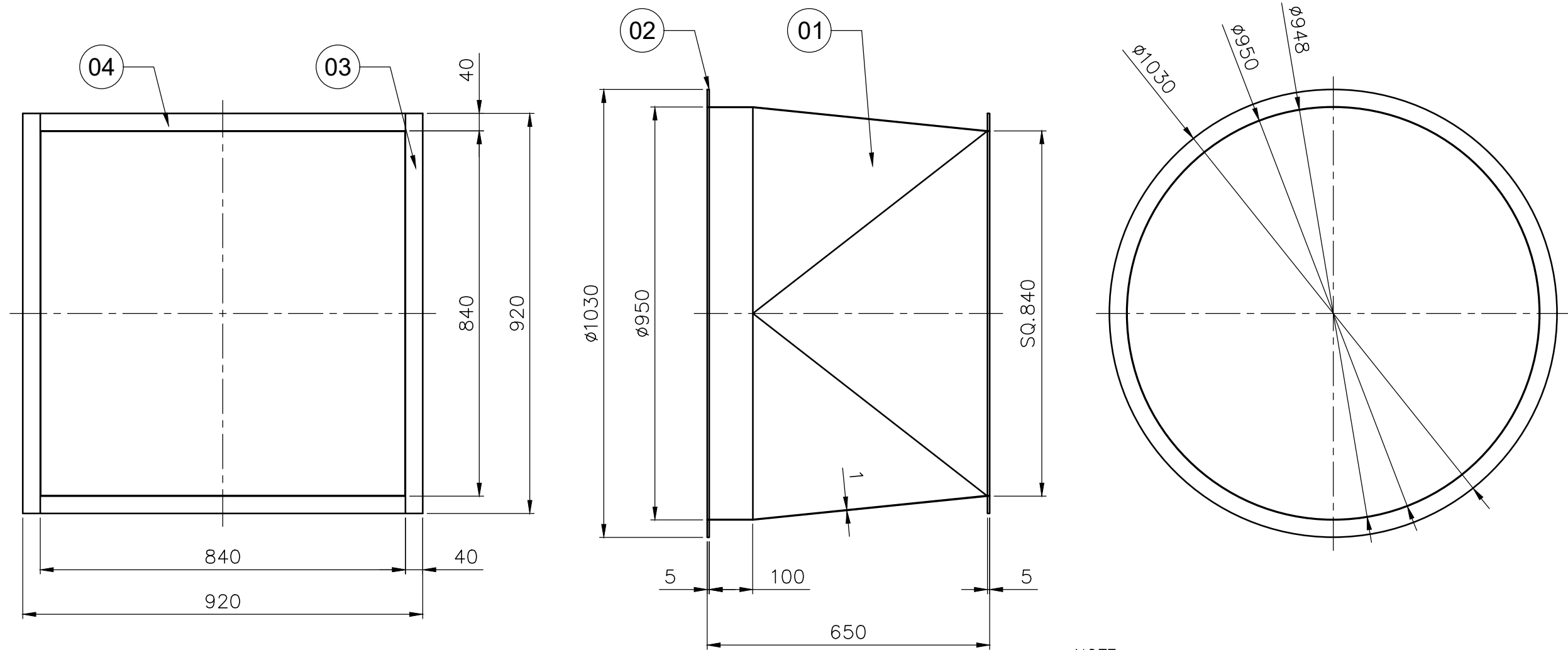

NOTE: -

01. SHARP EDGES TO BE REMOVED.

02. FLANGE MATTING HOLE PROVIDED AT SITE

04	PL 5t x 40 x 840	—	IS 6911	1.33
			STAINLESS STEEL 304	2
03	PL 5t x 40 x 920	—	IS 6911	1.46
			STAINLESS STEEL 304	2
02	PL 5t x 40 x 3110	—	IS 6911	5.00
			STAINLESS STEEL 304	1
01	St 1t x 650 x 3000	—	IS 6911	15.50
			STAINLESS STEEL 304	1

CAUTION: THE INFORMATION ON THIS DOCUMENT IS THE PROPERTY OF BHARAT HEAVY ELECTRICALS LIMITED. IT MUST NOT BE USED DIRECTLY OR INDIRECTLY IN ANY WAY DETRIMENTAL TO THE INTEREST OF THE COMPANY.

ITEM NO	DESCRIPTION	DRAWING NO	MATL CODE	UNIT WT
			MATL SPEC	QTY
EQPT: WATER WASH SPARY PAINTING BOOTH / RSK				
	Bharat Heavy Electricals Ltd		DRN	NAME
	HIGH PRESSURE BOILER PLANT		CHD	N.MADURAVEERAN
	TIRUCHIRAPALLI - 620014		APPD	A.DANASEKAR
DEPT	GRADE OF UNTOL. DIM	SCALE	WEIGHT (Kg)	REF TO ASSY DWG NO
M&S	φ/M/£	1:10	26.00	—
CODE	IS: 2102			REF TO OLD DWG NO
2597				—
TITLE			CARD CODE	REV
DUCT - 02 Ø950 x 650			U 01	00
(SUCTION BLOWER INLET)			DRAWING NO : 3-M-19A25-16456	

REV	DATE	ALTERED
		CHECKED
		APPROVED
ZONE		

Annexure B

Pre-Qualification Criteria

A. Pre-Qualification Criteria		
SL. No	Pre-Qualification Criteria	Vendor's Confirmation /Acceptance
	Only those vendors who satisfy the following conditions will get qualified to participate in the tender. If the vendor does not qualify as per pre-qualification criteria, the technical offer of such bidder / vendor offer will not be considered.	
1.	Previous purchase order (PO) details for supply and installation of similar kind of items to BHEL and/or any-other Organization should be submitted along with offer. Otherwise offer will be rejected.	

Supplier's Signature & Seal

Annexure – A- Additional Terms and Conditions for GeM Enquiry

The terms and condition mentioned in this document are applicable in addition to the GeM General Terms and Conditions. Bidders shall furnish pointwise confirmation/details.

<i>To be filled by bidder</i>		
Description of the Equipment:		
GeM Tender No. & Date		
Name of the firm (Bidder)		:
Address		:
Contact person 1		Contact person 2
Name:		Name:
Designation:		Designation:
Office Phone:		Office Phone:
Mobile:		Mobile:
e-mail:		e-mail:
Offer/Quotation reference with date		:
SI	Terms and conditions	Vendor's confirmation
1.	<p>Payment terms:</p> <ol style="list-style-type: none"> 1. Payment terms for Non MSME Suppliers: Within 90 days after CRAC 2. Payment terms for eligible Micro & Small Enterprises (MSEs): Within 45 days after CRAC. The supplier should upload UDYAM Registration Certificate in proof of MSE. 3. Payment terms for eligible Medium Enterprises: Within 60 days after CRAC. The supplier should upload UDYAM Registration Certificate in proof of Medium Enterprises. <p>Note:</p> <ol style="list-style-type: none"> 1. CRAC will be made only after completion of Installation of ducts. 2. In case of Auto PRC/CRAC, Payment due date shall be calculated from CRAC date or material acceptance date by BHEL whichever is later. 	
2.	Delivery Period: Supply and installation to be completed Within 30 days from the date of GeM contract	
3.	<p>Liquidated Damages: LD terms shall be as per GeM General Terms and Conditions.</p> <p>Note: Installation completion date will be considered for LD calculation (I.e. LD will be calculated for the Period from Contract delivery due date to the date of completion of installation at BHEL, Trichy).</p>	
4.	Response to Tenders for Indigenous supplier will be entertained only if the vendor has a valid GST registration number which should clearly mentioned in the offer. Indicate the GST registration number. If any specific exemption is available, a declaration with due supporting documents need to be furnished for considering the offer.	GST Registration No. _____
5.	The quoted price should be inclusive of all the charges for supply and Installation	
6.	Kindly Indicate the HSN Code for all items	HSN CODE : _____
7.	Rate quoted in GeM portal should be on FOR destination basis inclusive of all taxes, P&F, freight etc. Transit Insurance is under Supplier scope. Please indicate how much GST percentage is included in quoted price.	GST in %: _____

Vendor's Seal & Signature

Bid Specific Additional Terms and Conditions

1.	<p>Technical: Supply and Installation shall be made as per technical Specifications indicated in the enquiry. Bidder shall comply the technical specification as per the enquiry. Any clarifications/deviations to the specification requirements are to be clearly indicated.</p> <p>The quoted price should be inclusive of all the charges for supply and Installation.</p>
2.	Vendor offers will be considered for price bid opening subject to fulfilment of techno commercial suitability.
3.	Delivery Period: Supply and installation to be completed Within 30 days from the date of GeM contract
4.	<p>Firm Price: The quoted / finalised rates shall be Firm till execution of the supplies. Offer with PVC clause will not be considered.</p>
5.	<p>Payment terms:</p> <ol style="list-style-type: none"> 1. Payment terms for Non MSME Suppliers: Within 90 days after CRAC 2. Payment terms for eligible Micro & Small Enterprises (MSEs): Within 45 days after CRAC. The supplier should upload UDYAM Registration Certificate in proof of MSE. 3. Payment terms for eligible Medium Enterprises: Within 60 days after CRAC. The supplier should upload UDYAM Registration Certificate in proof of Medium Enterprises. <p>Note:</p> <ol style="list-style-type: none"> 1. CRAC will be made only after completion of Installation of ducts. 2. In case of Auto PRC/CRAC, Payment due date shall be calculated from CRAC date or material acceptance date by BHEL whichever is later.
6.	<p>Liquidated Damages: LD terms shall be as per GeM General Terms and Conditions. Note: Installation completion date will be considered for LD calculation (I.e. LD will be calculated for the Period from Contract delivery due date to the date of completion of installation at BHEL, Trichy).</p>
7.	<p>Delivery term: The quote shall be on FOR BHEL STORES (Consignee address) basis inclusive of Packing, forwarding, Freight also to yours account. Transit Insurance is under Supplier scope. The quoted price should be inclusive of all the charges for supply and Installation.</p>
8.	If Guarantee / Warranty period is applicable as per tender specification, No deviation is permitted and deviated offers are liable for rejection.
9.	Repair & replacements: Within the guarantee period vendor has to replace / rectify the defective/damaged items on free of cost within a reasonable time of reporting from our end.
10.	<p>Documents are to be submitted along with technical bid (Part-1)</p> <ol style="list-style-type: none"> 01. Duly Filled, signed and stamped Annexure – A (Additional Terms and Conditions for GeM Enquiry), Annexure-B (Pre-Qualification Criteria) and Specification document along with supporting documents. Annexure A and B are available along with Specification document. 02. Documents required as per technical specification 03. Product Catalogues (if any). 04. MSME UDYAM Certificate (if applicable). 05. If MII Purchase Preference is applicable as per the GeM enquiry, Self-certification for local content declaration as per Make In India Policy, bidder shall submit Local content certificate with details of minimum local content percentage and Location at which the local value addition is made. <p>Note: All the pages of documents are to be signed and sealed by authorized signatory of the company. Any query during enquiry stage shall be replied within two days failing which offer may be rejected as non-responsive.</p>
11.	<p>Inspection and testing requirements: Inspection and testing requirements are to be carried out as per the specification and BHEL Technical specifications in the enquiry. If applicable all test certificates are to be submitted while supply. If required by BHEL, test certificates to be produced before supply.</p>

12.	PACKING AND MARKING: The supplier shall arrange for securely protecting and packing the stores to avoid loss or damages during transit. (Wherever if applicable).Also, Supplier to comply for packing & marking as per Technical specification.
13.	Response to Tenders for Indigenous supplier will be entertained only if the vendor has a valid GST registration Number (GSTIN) which should be clearly mentioned in the offer. If the dealer is exempted from GST registration, a declaration with due supporting documents need to be furnished for considering the offer. Dealers under composition scheme should declare that he is a composition dealer supported by the screen shot taken from GSTN portal. The dealer has to submit necessary documents if there is any change in status under GST.
14.	Supplier shall mention their GSTIN in all their invoices (incl. credit Notes, Debit Notes) and invoices shall be in the format as specified/prescribed under GST laws. Invoices shall necessarily contain Invoice number (in case of multiple numbering system is being followed for billing like SAP invoice no, commercial invoice no etc., then the Invoice No. which is linked/uploaded in GSTN network shall be clearly indicated), Billed to party (with GSTIN) & Shipped to party details, item description as per PO, Quantity, Rate, Value, applicable taxes with nomenclature (like IGST, SGST, CGST & UTGST) separately, HSN/ SAC Code, Place of Supply etc. Wherever E-Invoice is applicable, the tax invoice/ CN / DN submitted by the vendor must contain the QR code generated in E-Invoice Portal & IRN.
15.	All invoices shall bear the HSN Code for each item separately (Harmonized System of Nomenclature)/ SAC code (Services Accounting Code).
16.	Invoices will be processed only upon completion of statutory requirement and further subject to following: <ul style="list-style-type: none"> • Vendor declaring such invoice in their GSTR-1 Return/ IFF • Receipt of Goods or Services and Tax invoice by BHEL.
17.	As the continuous uploading of tax invoices in GSTN portal (in GSTR-1/ IFF) is available for all (i.e. both Small & Large) tax payers, all invoices raised on BHEL may be uploaded immediately in GST portal on dispatch of material /rendering of services. The supplier shall ensure availability of Invoice in GSTN portal before submission of invoice to BHEL. Invoices will be admitted by BHEL only if the invoices are available in GSTN portal (in BHEL's GSTR-2A/ GSTR-2B).
18.	In case of discrepancy in the data uploaded by the supplier in the GSTN portal or in case of any shortages or rejection in the supply, then BHEL will not be able to avail the tax credit and will notify the supplier of the same. Supplier has to rectify the data discrepancy in the GSTN portal or issue credit note or debit note (details also to be uploaded in GSTN portal) for the shortages or rejections in the supplies or additional claims, within the calendar month informed by BHEL.
19.	In cases where invoice details have been uploaded by the vendor but failed to remit the GST amount to GST Department (Form PMT-08 or Form GST RET-01 to be submitted) within stipulated time, then GST paid on the invoices pertaining to the month for which GST return not filed by the vendor will be recovered from the vendor along with the applicable interest (currently 24% p.a) and all subsequent bills of the vendor will not be processed till filing of the GST return by the vendor
20.	In case GST credit is denied to BHEL due to non-receipt or delayed receipt of goods and/ or tax invoice or expiry of timeline prescribed in GST law for availing such ITC, or any other reasons not attributable to BHEL, GST amount claimed in the invoice shall be disallowed to the vendor.
21.	Where any GST liability arising on BHEL under Reverse Charge (RCM), the vendor has to submit the invoices to BHEL well within the timeline prescribed in GST Law, to enable BHEL to discharge the GST liability. If there is a delay in submission of invoice by the vendor resulting in delayed payment of GST by BHEL along with Interest, then such Interest payable or paid shall be recovered from the vendor.
22.	GST TDS will be deducted as per Section 51 of CGST Act 2017 and in line with Notification 50/2018 –Central Tax dated 13.09.2018. GST TDS certificate will be generated in GSTN portal subsequent to vendor accepting the TDS deduction in the GSTN portal & the vendor can directly download the Certificate from the GSTN Portal.

23.	<p>As per the provisions of Section 194Q of the Income Tax Act, we BHARAT HEAVY ELECTRICALS LIMITED, HPBP, TRICHY having PAN AAACB4146P, had turnover in the preceding financial year for more than Rs 10 Crores.</p> <p>Hence, we are liable as buyer to deduct tax at source on the payment for invoices issued by Supplier on or after 1st July 2021. Accordingly, discontinue charging TCS u/s 206C(1H) on invoices issued from 1st Jul 2021 onward.</p> <p>We shall deduct the eligible TDS u/s 194Q on the payments for invoices issued on or after 1st Jul 2021. TDS deducted so, shall be deposited to the Income Tax Department, and TDS certificate to this effect. Tax credit of such TDS shall reflect in FORM26AS of the supplier at the end of same quarter in which TDS is deducted.</p> <p>For Suppliers who have not filed Income Tax returns for the last 2 preceding assessment years, TDS deduction at higher rates will be applicable as per Section 206AB and Section 206CCA of Income-tax act.</p>
24.	BHEL will be deducting TDS u/s 194Q TDS. Hence TCS shall not be claimed in Supplier's Invoice.
25.	GST CREDIT: Suppliers are advised to get registered to GSTN portal. Tenderer under "GST credit" shall be preferred.
26.	Any change in applicable rates of Tax or any other statutory levies (Direct / Indirect) or any new introduction of any levy by means of statute and its corresponding liability for the deliveries beyond the agreed delivery date for reasons not attributable to BHEL will be to vendors account. BHEL will not reimburse the same and any subsequent claim in this respect will be summarily rejected.
27.	<p>MSE /START-UP VENDOR: UDYAM Registration certificate shall be submitted by MSE vendors to avail MSE benefits. Start-up category certificate shall be submitted by start-up companies to avail exemption (if applicable as per GeM enquiry) in Annual Turnover/Past experience (if PQC stipulates requirement of Annual Turnover/Past experience).</p>
28.	<p>Make in India Policy: Refer the Tender document regarding public procurement policy (Preference to Make in India), Order 2017. If MII Purchase Preference is applicable as per the tender documents, Bidders shall ensure to apply for Make In India preference while quoting through GeM portal. Otherwise offer will not be considered.</p> <p>The local supplier at the time of tender, bidding or solicitation shall be required to provide self-certification that the item offered meets the minimum local content and shall give details of the Location(s) at which the local value addition is made."</p>
29.	<p>Fraud Prevention Policy Bidder along with its associate /collaborators /sub-contractors /sub-vendors / consultants / service providers shall strictly adhere to BHEL Fraud Prevention Policy displayed on BHEL website http://www.bhel.com and shall immediately bring to the notice of BHEL Management about any fraud or suspected fraud as soon as it comes to their notice.</p>

30.	<p>Breach of contract, Remedies and Termination:</p> <p>In case of breach of contract, wherever the value of security instruments like performance bank guarantee available with BHEL against the said contract is 10% of the contract value or more, such security instruments to the extent of 10% contract value will be encashed. In case no security instruments are available or the value of the security instruments available is less than 10% of the contract value, the 10% of the contract value or the balance amount, as the case may be, will be recovered in all or any of the following manners:</p> <p>a. from dues available in the form of Bills payable to defaulted supplier against the same contract.</p> <p>b. from the dues payable to defaulted supplier against other contracts in the same Region/Unit /any other region/unit</p> <p>c. In-case recoveries are not possible with any of the above available options, Legal action shall be initiated for recovery against defaulted supplier.</p> <p>Further, levy of liquidated damages, debarment, termination, de-scoping, short-closure, etc., will be applied as per provisions of the contract</p>
31.	<p>CONFLICT OF INTEREST:</p> <p>A bidder shall not have conflict of interest with other bidders. Such conflict of interest can lead to anti-competitive practices to the detriment of Procuring Entity's interests. The bidder found to have a conflict of interest shall be disqualified. A bidder may be considered to have a conflict of interest with one or more parties in this bidding process, if:</p> <p>a) they have controlling partner (s) in common; or</p> <p>b) they receive or have received any direct or indirect subsidy financial stake from any of them; or</p> <p>c) they have the same legal representative/agent for purposes of this bid; or</p> <p>d) they have relationship with each other, directly or through common third parties, that puts them in a position to have access to information about or influence on the bid of another Bidder; or</p> <p>e) Bidder participates in more than one bid in this bidding process, Participation by a Bidder in more than one Bid will result in the disqualification of all bids in which the parties are involved. However, this does not limit the inclusion of the components/ sub-assembly/ Assemblies from one bidding manufacturer in more than one bid: or</p> <p>f) In cases of agents quoting in offshore procurements, on behalf of their principal manufacturers, one agent cannot represent two manufacturers or quote on their behalf in a particular tender enquiry. One manufacturer can also authorise only one agent/dealer. There can be only one bid from the following:</p> <ol style="list-style-type: none"> 1. The principal manufacturer directly or through one Indian agent on his behalf; and 2. Indian/foreign agent on behalf of only one principal; <p style="text-align: center;">or</p> <p>g) A Bidder or any of its affiliates participated as a consultant in the preparation of the design or technical specifications of the contract that is the subject of the Bid, or</p> <p>h) In case of a holding company having more than one independently manufacturing units, or more than one unit having common business ownership/Management, only one unit shall quote. Similar restrictions would apply to closely related sister companies. Bidder must proactively declare such sister/common business/ management units in same/similar line of business.</p>
32.	<p>Resolution of Disputes:</p> <p>The Parties agree that if at any time (whether before, during or after the arbitral or judicial proceedings), any Disputes (which term shall mean and include any dispute, difference, question or disagreement arising in connection with construction, meaning, operation, effect, interpretation or breach of the contract/tender which the Parties are unable to settle mutually),</p>

	<p>arise inter-se the Parties, the same may, be referred by either party to Conciliation to be conducted through Independent Experts Committee to be appointed by competent authority of BHEL from the BHEL Panel of Conciliators.</p> <p>Notes:</p> <p>No serving or a retired employee of BHEL/Administrative Ministry of BHEL shall be included in the BHEL Panel of Conciliators.</p> <p>Any other person(s) can be appointed as Conciliator(s) who is/are mutually agreeable to both the parties from outside the BHEL Panel of Conciliators.</p> <p>The proceedings of Conciliation shall broadly be governed by Part-III of the Arbitration and Conciliation Act 1996 or any statutory modification thereof and as provided in Annexure X to this Terms and conditions.</p> <p>The Annexure X together with its appendices will be treated as if the same is part and parcel hereof and shall be as effectual as if set out herein in this terms and conditions.</p> <p>Except as provided elsewhere in this Contract, in case amicable settlement is not reached between the parties, in respect of any dispute or difference; arising out of the formation, breach, termination, validity or execution of the Contract; or, the respective rights and liabilities of the Parties; or, in relation to interpretation of any provision of the Contract; or, in any manner touching upon the Contract, then, either Party may, by a notice in writing to other Party, refer such dispute or difference to sole arbitration of an arbitrator appointed as per the Arbitration and Conciliation Act, 1996 (India) or statutory modification or re-enactment thereof and the rules made thereunder and for the time being in force.</p> <p>The Arbitrator shall pass a reasoned award and the award of the Arbitrator shall be final and binding upon the parties.</p> <p>This contract shall be governed, construed and interpreted in accordance with the laws of India. Subject as aforesaid, the provisions of Arbitration & Conciliation Act 1996 (India) or statutory modification or re-enactment thereof and the rules made thereunder and for the time being in force shall apply to the arbitration proceeding under this clause.</p> <p>The seat of arbitration shall be Trichy, Tamil Nadu, India</p> <p>The cost of arbitration shall be borne as per the award of the Arbitrator.</p> <p>Subject to arbitration in terms of clause above, the Courts at Trichy, Tamil Nadu, India shall have exclusive jurisdiction over any matter arising out of or in connection with this Contract.</p> <p>Notwithstanding the existence or any dispute or difference and/or reference for the arbitration, the vendor/contractor shall proceed with and continue without hindrance the performance of its obligation under this Contract with due diligence and expedition in a professional manner except where the Contract has been terminated by either Party in terms of this Contract.</p> <p>In Case of Contract with Public Sector Enterprise (PSE) or a Government Department, the following shall be applicable:</p> <p>In the event of any dispute or difference relating to the interpretation and application of the provisions of commercial contract(s) between Central Public Sector Enterprises (CPSEs)/Port Trusts inter se and also between CPSEs and Government Departments/Organizations (Excluding disputes concerning Railways, Income Tax, Customs & Excise Departments, such dispute or difference shall be taken up by either party for its resolution through AMRCD as mentioned in DPE OM No.05/003/2019-FTS-10937 dtd. 14TH December, 2022 and the decision of AMRCD on the said dispute will be binding on both the parties.”</p>
33.	Set off : BHEL shall have the right to recover any money which in the sole opinion of BHEL is due from the supplier from any money due to the supplier under this Contract or any other contract or from the Security Deposit/BG furnished by the supplier under this Contract or any other contract.
34.	<p>Cartel Formation:</p> <p>The Bidder declares that they will not enter into any illegal or undisclosed agreement or understanding, whether formal or informal with other Bidder(s). This applies in particular to prices, specifications, certifications, subsidiary contracts, submission or non-submission of bids or any other actions to restrict competitiveness or to introduce cartelization in the bidding process. In case, the Bidder is found having indulged in above activities, suitable action shall be taken by BHEL as per extant policies/ guidelines.</p>

35.	The offers of the bidders who are under suspension and also the offers of the bidders, who engage the services of the banned firms /principal/agents, shall be rejected. The list of banned firms is available on BHEL web site www.bhel.com
36.	The following documents are to be sent along with consignment to store: One Original for Recipient copy of tax invoice + One Duplicate for Transporter copy of tax invoice + One extra copy of tax invoice + Delivery challan + LR COPY+E-Way bill (Part A & Part B)+ Test Certificates (if applicable).
37.	Seller Tax invoice, LR copy, E-Way bill, Courier docket etc. are to be uploaded in GeM portal while updating dispatch details in GeM portal
38.	Seller Tax invoices (Original for Recipient + Duplicate for Transporter) either in Original hard copies or Digitally Signed Soft copies along with copy of LR/Courier docket + Part B of E-Way bill are to be sent to the buyer for bill processing
39.	Bidder financial standing: The bidder should not be under liquidation, court receivership or similar proceedings, should not be bankrupt. Bidder to upload undertaking to this effect with bid.
40.	Bidder's offer is liable to be rejected if they don't upload any of the certificates / documents sought in the Bid document, ATC and Corrigendum if any.
41.	Any other conditions which might have been quoted by the seller and are in contravention to the terms prescribed in the Enquiry documents and which have not been specifically accepted in by purchaser will not be applicable to the contract.
42.	Without prejudice to Buyer's right to price adjustment by way of discount or any other right or remedy available to Buyer, Buyer may terminate the Contract or any part thereof by a written notice to the Seller, if: The Seller fails to comply with any material term of the Contract. The Seller informs Buyer of its inability to deliver the Material(s) or any part thereof within the stipulated Delivery Period or such inability otherwise becomes apparent. The Seller fails to deliver the Material(s) or any part thereof within the stipulated Delivery Period and/or to replace/rectify any rejected or defective Material(s) promptly. The Seller becomes bankrupt or goes into liquidation. The Seller makes a general assignment for the benefit of creditors. A receiver is appointed for any substantial property owned by the Seller. The Seller has misrepresented to Buyer, acting on which misrepresentation Buyer has placed the Purchase Order on the Seller.
43.	BHEL may negotiate the L1 rate, if not meeting our budget / estimated cost. BHEL may re-float the tender opened, if L1 price is not acceptable to BHEL.
44.	In case of any queries before bid submission, the supplier may reach us at the mail id govindaraj@bhel.in