

Technical Specifications

SL. No	Description and Technical Specification of the item	QTY	UNIT	Delivery
1.	<p>Inductor Assembly 480DW90:</p> <p>Specification: 480DW90 Inductor set (Complete set consisting of Inductor Ring, Quench Ring, Air Ring and Mounting Parts) required for bending following pipe in PB1200 machine (M/c SI No.: BH9901) Pipe Size: ID 300 mm x 90 mm (thickness) x 4000 mm (length). Pipe Material: SA335P92.</p> <p>INDUCTOR: 2M-12A23-06150/00 (AS PER SL. No.03), AIR RING: 3M-12A24-14416/02 (AS PER SL. No.09), QUENCH RING: 2M-12A24-04901/01 (AS PER SL. No.09), SUB DRG. No: Flange :3M-12A23-16187/00, Strips and Blocks:2M-12A18-04364 (ref dwg only), Strips:4M-12A-18-26664 (ref dwg only). Inductor Coil ID-600mm with 40x30mm rectangular copper tubing (Double turn)</p>	1	SET	90 DAYS
2.	<p>Inductor Assembly 575DW90:</p> <p>Specification: 575DW90 Inductor set (Complete set consisting of Inductor Ring, Quench Ring, Air Ring and Mounting Parts) required for bending following pipe in PB1200 machine (M/c SI No.: BH9901). Pipe Size: ID 320 mm x 105 mm (thickness) x 8000 mm (length). Pipe Material: SA335P91.</p> <p>INDUCTOR: 2M-12A23-06150/00 (AS PER SL. No.04), AIR RING: 3M-12A24-14416/02 (AS PER SL. No.10), QUENCH RING: 2M-12A24-04901/01 (AS PER SL. No.10), SUB DRG. No: Flange :3M-12A23-16187/00, Strips and Blocks:2M-12A18-04364 (ref dwg only), Strips:4M-12A-18-26664 (ref dwg only). Inductor Coil ID-695mm with 40x30mm rectangular copper tubing (Double turn)</p>	1	SET	90 DAYS
3.	<p>Insulation Ring 1:</p> <p>Specification: Mica Insulation Ring 1 Specification: OD: 30 mm x ID: 16.2 +/- 0.2 mm x Thick: 3 mm</p>	100	NO	90 DAYS

4.	Insulation Ring 2: Mica Insulation Ring 2 Specification: OD: 20 mm x ID: 10.2 +/- 0.2 mm x Thick: 2 mm	100	NO	90 DAYS
5.	Insulation Bush 1: Mica Insulation Bush 1 Specification: OD: 16 +/-0.3 mm x ID: 12.2 +/-0.2 mm x Length: 20 +/-0.3 mm	100	NO	90 DAYS
6.	Insulation Bush 2: Mica Insulation Bush 2 Specification: OD: 16 +/-0.3 mm x ID: 12.2 +/-0.2 mm x Length: 11 +/-0.3 mm	100	NO	90 DAYS
7.	Insulation Bush 3: Mica Insulation Bush 3 Specification: OD: 14 mm x ID: 10 mm x Length: 20 mm	100	NO	90 DAYS
8.	Insulation Bush 4: Mica Insulation Bush 4 Specification: OD: 21 mm x ID: 6 mm x Length: 16 mm	100	NO	90 DAYS
9.	Strip as per drawing 1: Specification: Strip as per drawing 1	100	NO	90 DAYS
10.	Strip as per drawing 2: Specification: Strip as per drawing 2	50	NO	90 DAYS
11.	Block as per drawing 3: Specification: Block as per drawing 3	100	NO	90 DAYS
12.	Block as per drawing 4: Specification: Block as per drawing 4	100	NO	90 DAYS
13.	Washer (Brass):	100	NO	90 DAYS

	Specification: OD: 20 mm x ID: 8 mm x Length: 6 mm Material Brass: CuZn39Pb3			
14.	Pivot Block as per drawing 5: Specification: Pivot Block as per drawing 5	100	NO	90 DAYS

Special instructions for item Note no 10 and 20:

Acceptance criteria:

1. Test certificates for Inductor raw material/composition from government approved/NABL accredited lab to be sent to BHEL. for clearance before manufacturing inductors.
2. Vendor may visit BHEL works if required, before manufacturing for better understanding the product requirement.
3. Pre-dispatch inspection (PDI) at vendor works is applicable. Vendor has to inform BHEL after manufacturing for Inspection.
4. Delivery: The inductors shall be manufactured and dispatched only after clearance from BHEL. The delivery shall be within 1 month from date of clearance by BHEL.
5. Final Acceptance will be given after the satisfactory performance of inductor sets at BHEL PPPU Thirumayam.

Sign. of the AUTHORISED SIGNATORY
(With Name, Designation and Company seal)

Pre-Qualification criteria

OEM details:

Sl.No	Name of the supplier	Address
1	M/S Intek Engineering Pvt.Ltd Address : T-3/450, Dehu-Alandi Road , Talwade, Pune- 411062.	Contact details: Mr.R.S.Pillai, Director E-Mail: rajpillai2404@gmail.com; Ph.:9890447678

S.No	Requirement	Remarks
1	The Bidder shall be OEM M/s Intek Engineering Pvt.Ltd .	
2	In case of dealer, valid dealership certificate shall be submitted along with offer	

Sign. of the AUTHORISED SIGNATORY
(With Name, Designation and Company seal)

ALL DIMENSIONS ARE IN MILLIMETERS

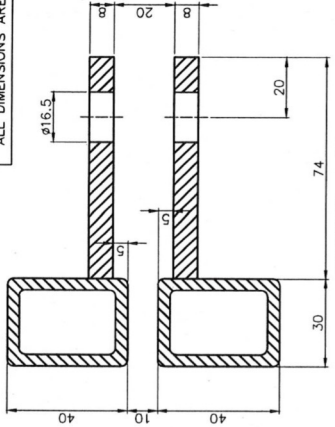

SECTION - AA

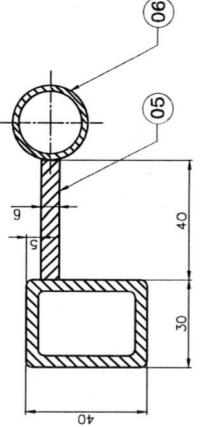

SECTION - BB

02	530	650	710	90	800
01	593	713	773	90	860
SL NO	#PIPE	#A	#B	C	D
03	480	600	660	90	750
04	575	695	755	90	860

06	TUBE #25 x 2 x 30L	-	-	IS 410	0.03
05	PL 6 x 30 x 40	-	-	ASTM A55 C 38500	0.08
04	PL 8 x 40 x 74	-	-	ASTM A55 C 38500	0.18
03	FLANGE 45 x 80 x 120	3-M-12A23-16187	-	IS 191	3.24
02	RECT.TUBE 40 x 30 x 4 x 457L	-	-	ASTM B75 C 12200	2.00
01	RECT.TUBE 40 x 30 x 4 x 4857L	-	-	ASTM B75 C 12200	21.40
ITEM NO	DESCRIPTION	DRAWING NO	MATL CODE	UNIT WT	QTY

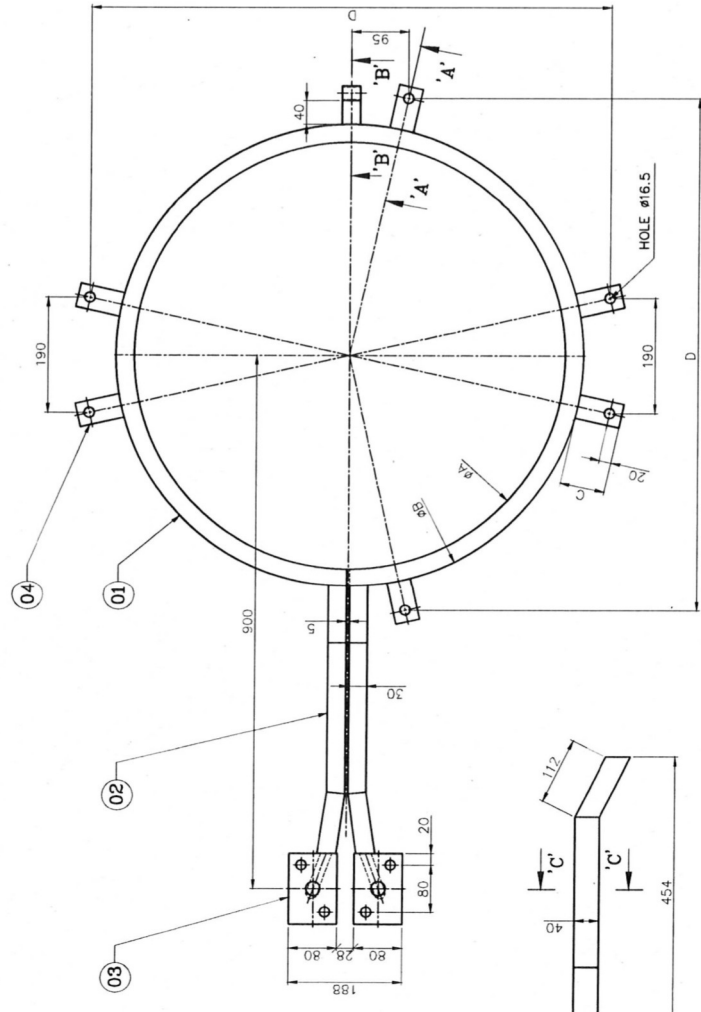
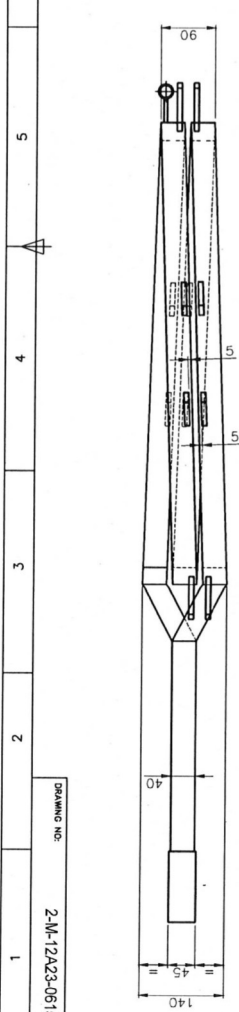

NOTE:-
 01. ALL JOINTS BY TIG WELDING.
 02. OVALITY SHOULD BE +5MM.
 03. FOR ALL WELD JOINTS SUITABLE EDGE PREPARATION TO BE CARRIED OUT BEFORE WELDING.
 04. ALL TUBES ARE EXTRUDED AND MADE UP OF SINGLE PIECE WITHOUT ANY JOINTS.

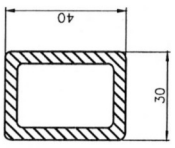

SECTION - CC

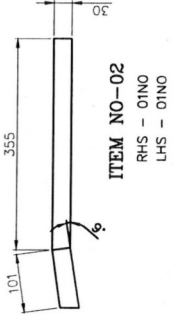

ITEM NO-02
 RHS - 01NO
 LHS - 01NO

CAUTION: THE INFORMATION ON THIS DOCUMENT IS THE PROPERTY OF BHARAT HEAVY ELECTRICALS LIMITED. ANY REPRODUCTION OR TRANSMISSION IN ANY FORM WITHOUT THE WRITTEN PERMISSION OF THE COMPANY.

Bharat Heavy Electricals Ltd
 HIGH PRESSURE BOILER PLANT
 TIRUCHIRAPPALLI - 620014

SCALE: 1:5.11

WEIGHT (Kg): 38.00

REF TO OLD Dwg NO: /

REF TO OLD Dwg NO: /

DATE: 22.07.20

DESIGNED BY: HANUMANTHAN

CHECKED BY: ADAMASBAR

APPROVED BY: ADAMASBAR

DATE: 22.07.20

ITEM NO: 01

REV: 01

DRAWING NO: 2-M-12A23-06150

REV: 01

A2-SIZE

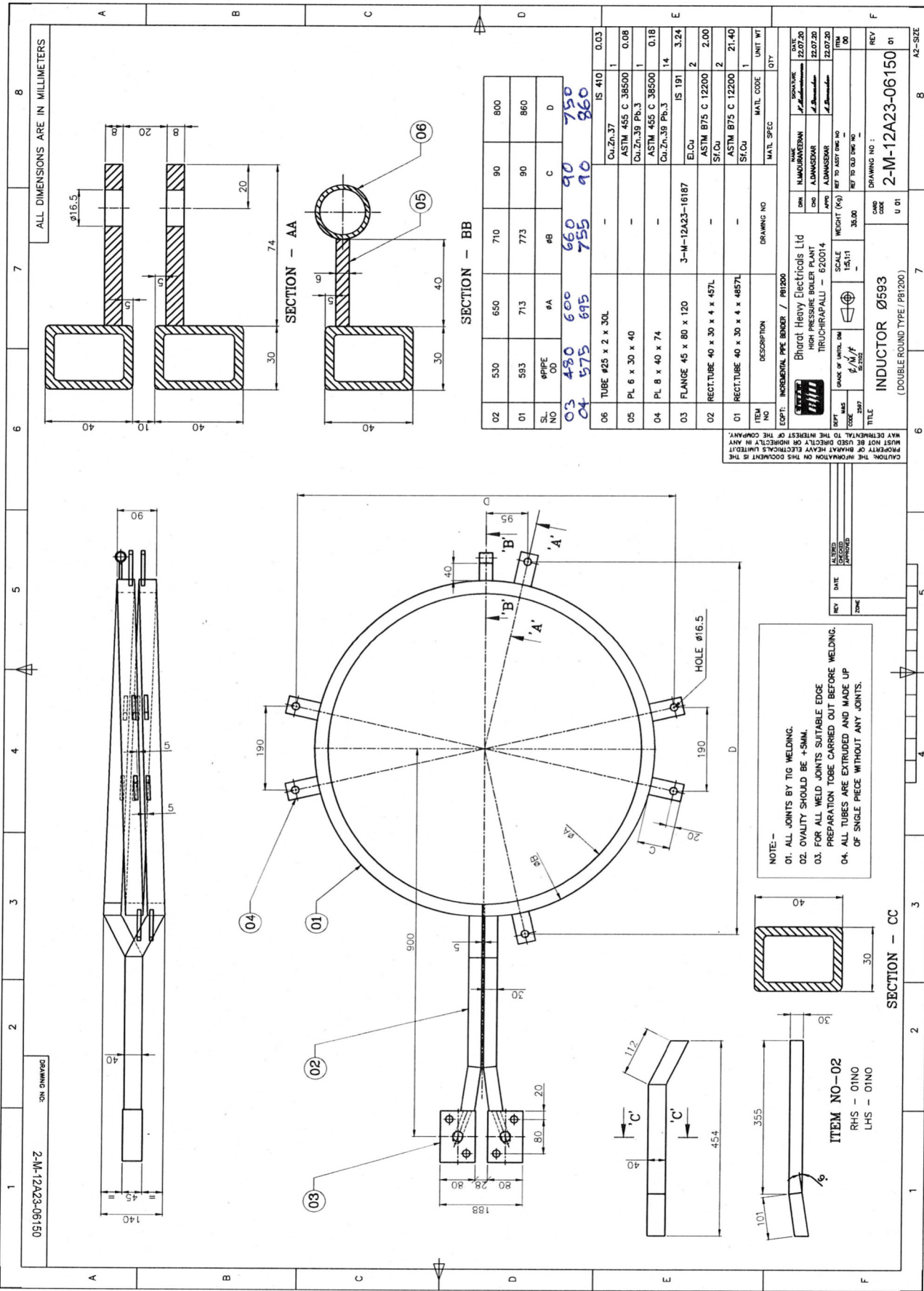

CAUTION: THIS DRAWING IS OUR SOLE PROPERTY AND SHOULD NOT BE USED IN ANY FORM FOR ANY PURPOSE WITHOUT THE WRITTEN PERMISSION OF BHARAT HEAVY ELECTRICALS LIMITED. TRICHRAPALLI - 620 014

ALL DIMENSIONS ARE IN MM

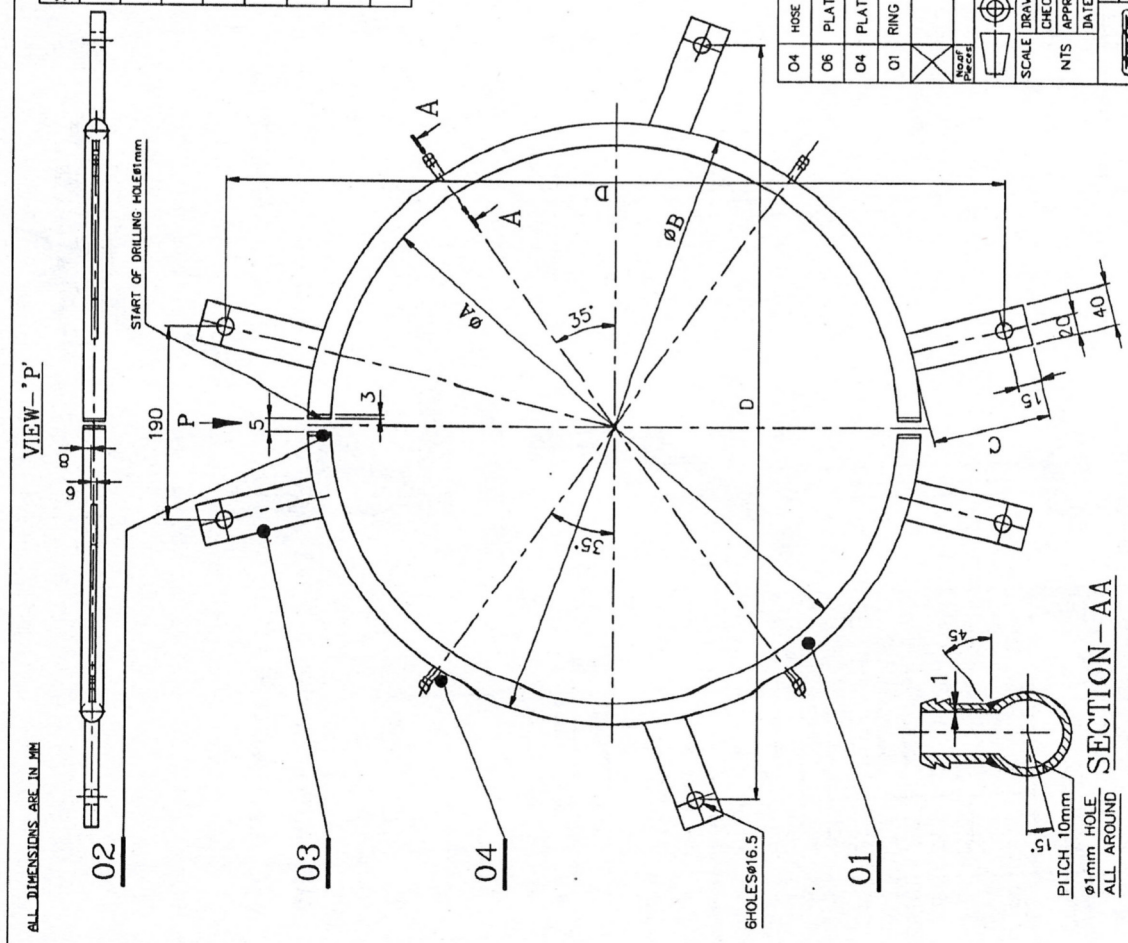

SL.NO.	PIPE Ø	øA	øB	C	D
01	508	610	654	99	800
02	526	630	674	95	800
03	543	650	694	94	850
04	559	670	714	94	850
05	610	720	764	92	900
06	660	770	814	92	950
07	670	780	824	90	950
08	720	830	840	88	1000
09	480	580	624	100	750
10	575	685	729	94	860

NOTE: 09 480 580 624 100 750
10 575 685 729 94 860

01. ALL JOINTS BY TIG WELDING.
02. OVALITY SHOULD BE +5mm
03. FOR ALL WELD JOINTS, SUITABLE EDGE PREPARATION TO BE CARRIED OUT BEFORE WELDING
04. ALL TUBES ARE EXTRUDED AND MADE UP OF SINGLE PIECE WITHOUT ANY JOINTS

ITEM No.	DESCRIPTION	MATERIAL	STANDARD	NET.WT. IN KGS.	DRAWING No.	REV.
04	HOSE CONNECTION FOR HOSE ØD13	BRASS	IS: 6912			
06	PLATE 8x40x C	CuZn39Pb3	ASTM 455 C 38500			
04	PLATE 2x922	CuZn39Pb3	ASTM 455 C 38500			
01	RING TUBE ø22x1.5t x L	CuZn37	IS: 410		ZM12A2404810 ZM12A1804914	01

ALTERATIONS:	UN	REF	DATE	SIGN.	INDEX
TABULATION ADDED					01
ITEM NO. 3 PLATE					02
8MM WAS 6MM			03.06.11		

SCALE	DRAWN/TCR	S.Selvamaniakam
CHECKED	R.RAMAMOORTHY	
APPROVED	C.S.JAYASHEELAN	
DATE	19.12.09/24.02.10	

MACHINE:	INCREMENTAL PIPE BENDER
TITLE:	AIR RING (PIPE ø508-ø720)
TYPE:	PB1400HE (1200R)
DRAWING No:	3M12A2414416
REV:	02
Sheet No:	
No of Sheets	

ALL DIMENSIONS ARE IN MILLIMETRES

3.2/

3-M-12A23-16187 DRAWING NO:

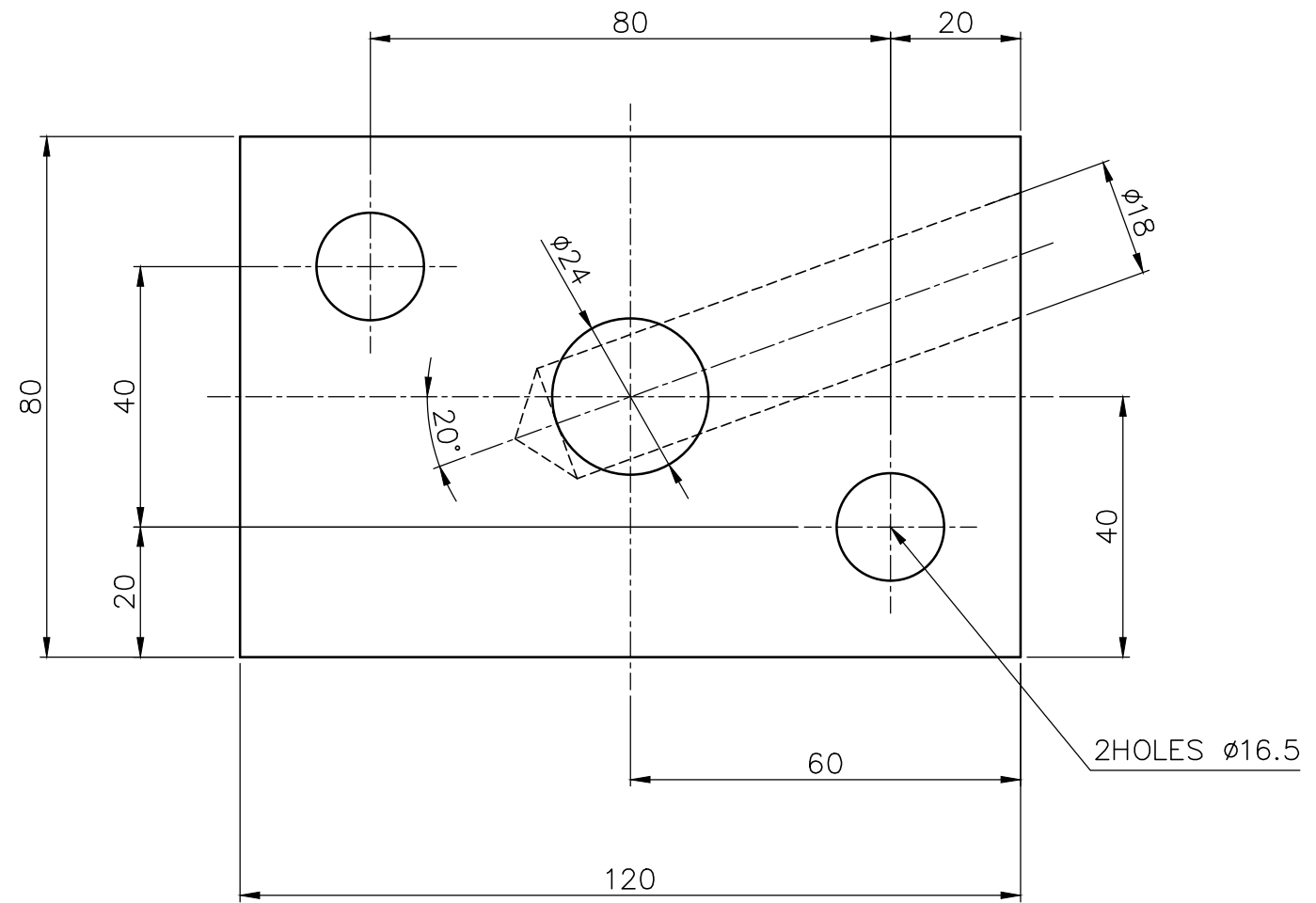
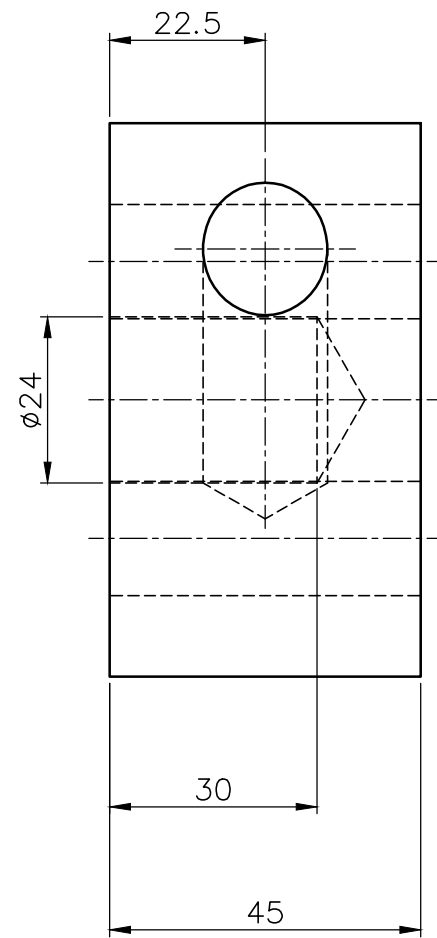

QUANTITY
 RIGHT HAND FLANGE - 01 NO.
 LEFT HAND FLANGE - 01 NO.

NOTE: -
 01. SHARP EDGES TO BE REMOVED

REV	DATE	ALTERED
		CHECKED
		APPROVED
ZONE		

ITEM NO	DESCRIPTION	DRAWING NO	IS 191	3.24		
			EI.Cu	1		
EQPT:	INCREMENTAL PIPE BENDER / PB1200		MATL CODE	UNIT WT		
			MATL SPEC	QTY		
DEPT M&S	GRADE OF UNTOL. DIM φ/M/£ IS: 2102	SCALE 1:1	NAME	SIGNATURE	DATE	
			DRN	N.MADURAVEERAN	<i>N. maduraveeran</i>	30.07.20
			CHD	A.DANASEKAR	<i>A. Danasekar</i>	30.07.20
APPD	A.DANASEKAR	<i>A. Danasekar</i>	30.07.20			
CODE	2597	WEIGHT (Kg)	3.24	REF TO ASSY DWG NO 2-M-12A23-06150	ITEM 03	
TITLE			DRAWING NO :		REV	
FLANGE 45 x 80 x 120 (INDUCTOR Ø593)			3-M-12A23-16187		00	
			CARD CODE			
			U 01			

CAUTION: THE INFORMATION ON THIS DOCUMENT IS THE PROPERTY OF BHARAT HEAVY ELECTRICALS LIMITED. IT MUST NOT BE USED DIRECTLY OR INDIRECTLY IN ANY WAY DETRIMENTAL TO THE INTEREST OF THE COMPANY.

CAUTION: THIS DRAWING IS OUR SOLE PROPERTY AND NOT TO BE REPRODUCED OR USED FOR ANY PURPOSE WITHOUT THE WRITTEN PERMISSION OF BHARAT HEAVY ELECTRICALS LIMITED TRICHIRAPPALLI - 620 014.

ALL DIMENSIONS ARE IN MM

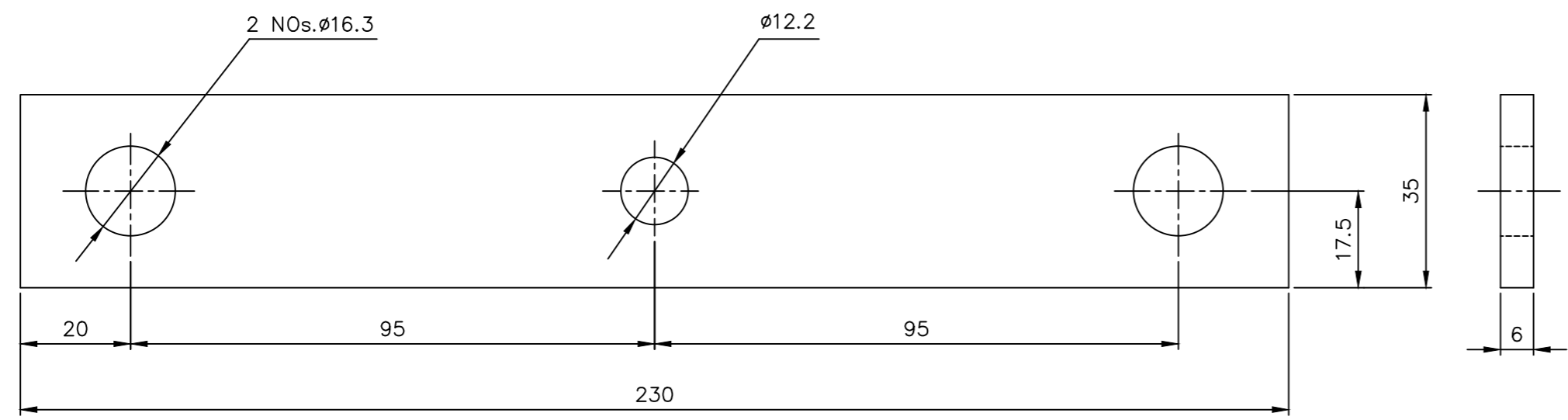

ITEM-04 REF: -48,55,0351/4

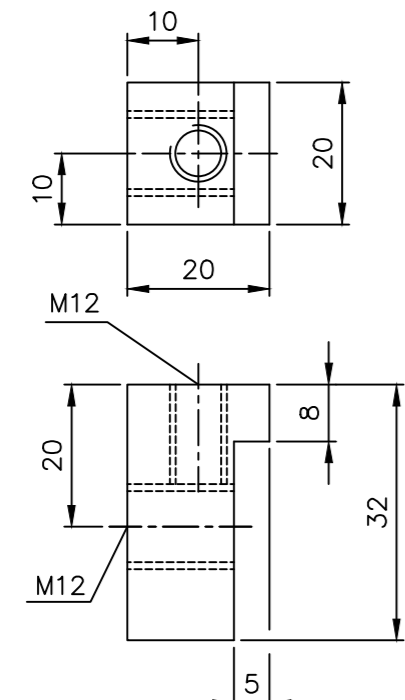

ITEM-06
REF: -48,55,0353/4

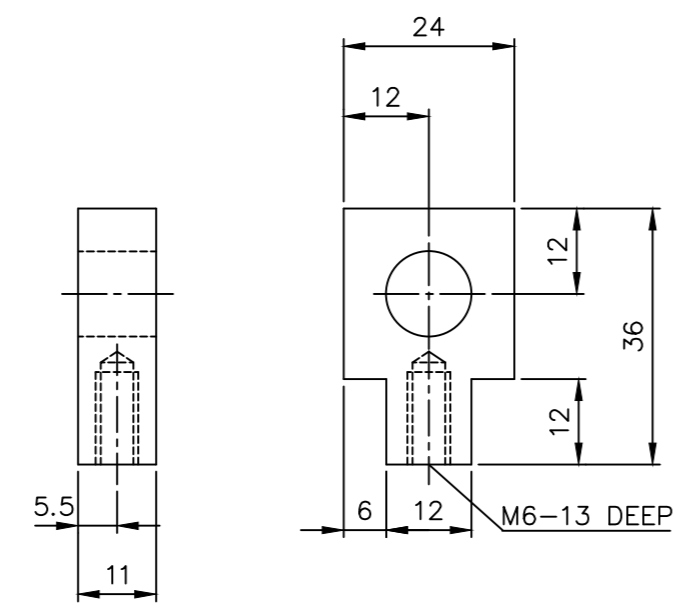

ITEM-05
REF: -48,55,0354/4

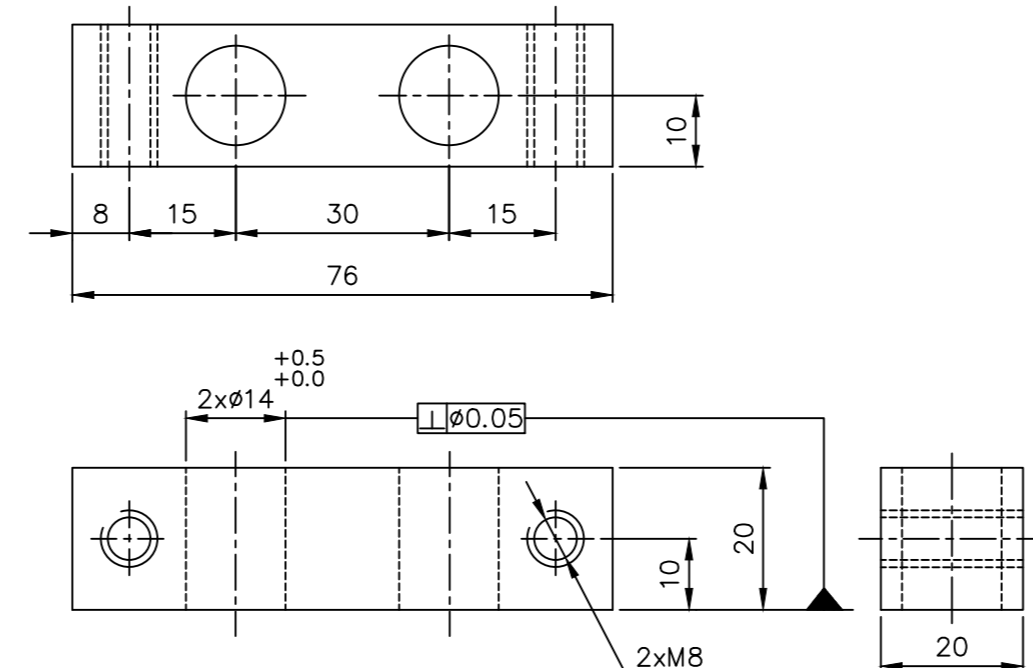

ITEM-10 REF: -48,55,0360/4

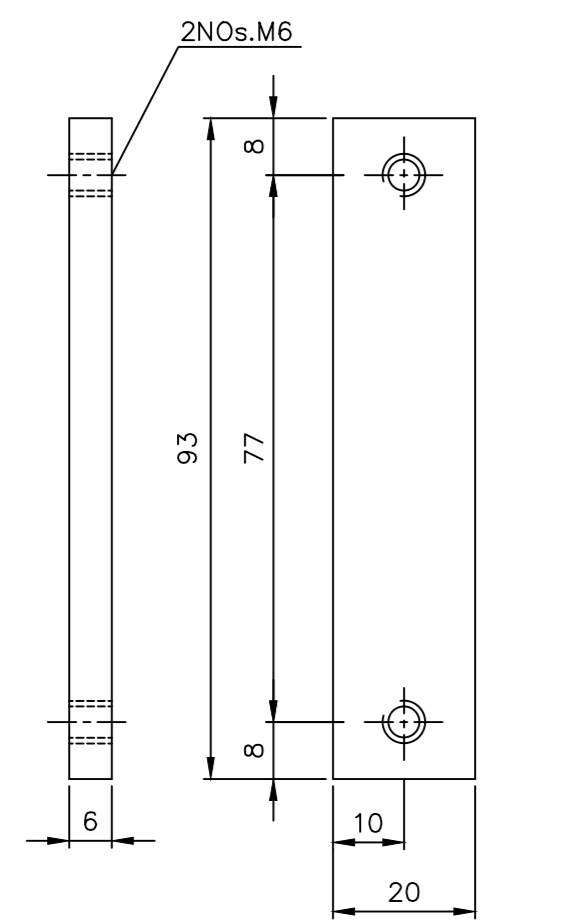

ITEM-07 REF: -48,55,0358/4

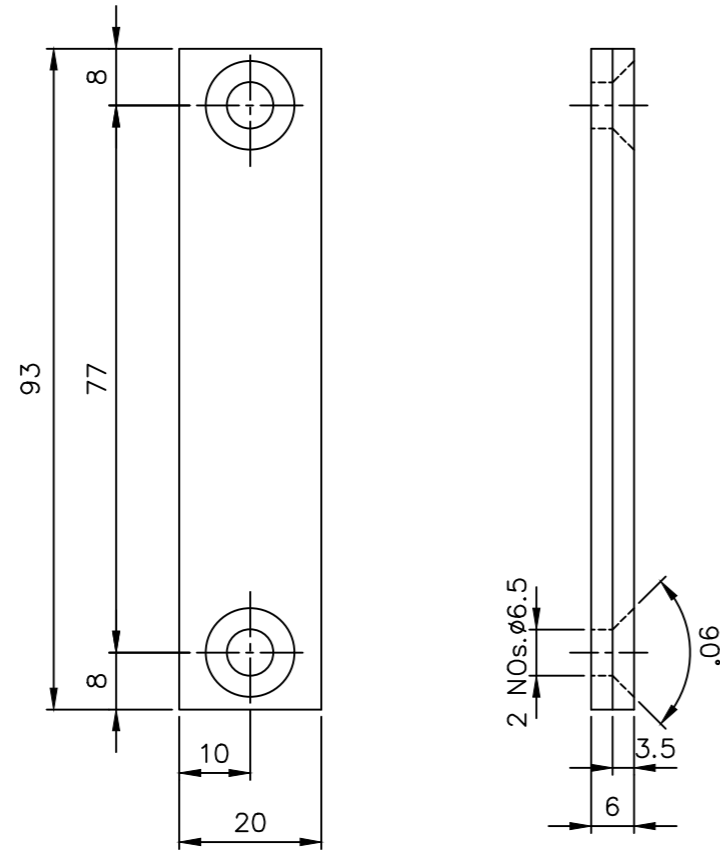

ITEM-08
REF: -48,55,0357/4

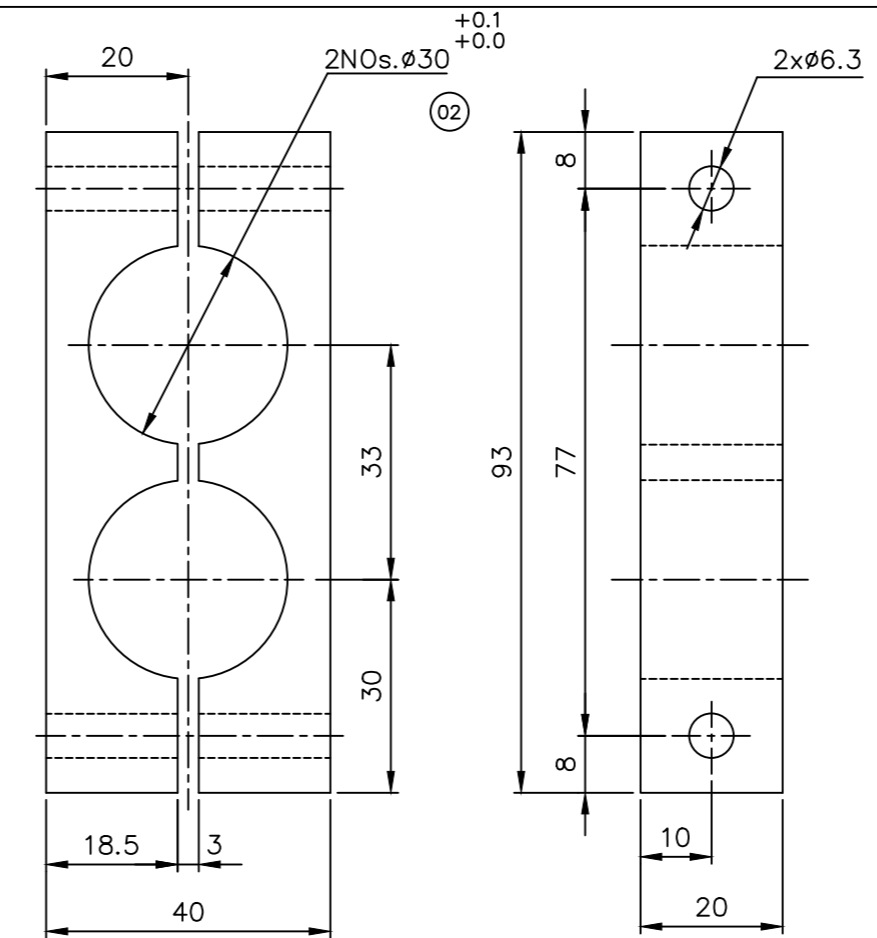

ITEM-09
REF: -48,55,0207/4

NOTE: -
 CHAMFER SHARP CORNERS TO 1/45°
 GRADE OF UNTOL.DIM IS: 2102 (MEDIUM)

	PIVOT BLOCK SQ.20x76	Cu.Zn.39Pb3	ASTM 455 C 38500			10
	CLAMP 20x40x93	HYLUM				09
	STRIP 6x20x93		AISI 316			08
	STRIP 6x20x93		AISI 316			07
	BLOCK SQ.20x32	Cu.Zn.39Pb3	ASTM 455 C 38500			06
	BLOCK 11x24x36	Cu.Zn.39Pb3	ASTM 455 C 38500			05
	STRIP 6x35x230		AISI 316			04
					2M12A2404810 2M12A2304808 2M12A1804914 2M12A1804365	
No. of Pieces	DESCRIPTION	MATERIAL	STANDARD	NET.WT.IN KGS.	DRGNO/MATL CODE	ITEM No.
	REFERENCE:		ALTERATIONS:	DCN REF	DATE	SIGN.
SCALE	DRAWN	P.A.ROSS	DRG. MODIFIED TO DATE		15.03.12	CSJ (01)
	CHECKED	R.RAMAMOORTHY	DRG. MODIFIED TO DATE		31.01.15	GGR (02)
1:1	APPROVED	C.S.JAYASHEELAN	TOLERANCE STANDARED ADDED		05.08.20	NMV (03)
	DATE	25-10-2000/28-12-10				
	MACHINE: INCREMENTAL PIPE BENDER			TYPE: PB 1400HE, PB 1200R, PB 600R		
	TITLE:			DRAWING No.		
	STRIPS & BLOCKS			2M12A180436403		
	Sheet No.			No. of Sheets		

CAUTION: THIS DRAWING IS OUR SOLE PROPERTY AND SHOULD NOT BE USED IN ANY FORM FOR ANY PURPOSE WITHOUT THE WRITTEN PERMISSION OF BHARAT HEAVY ELECTRICALS LIMITED

ALL DIMENSIONS ARE IN MM

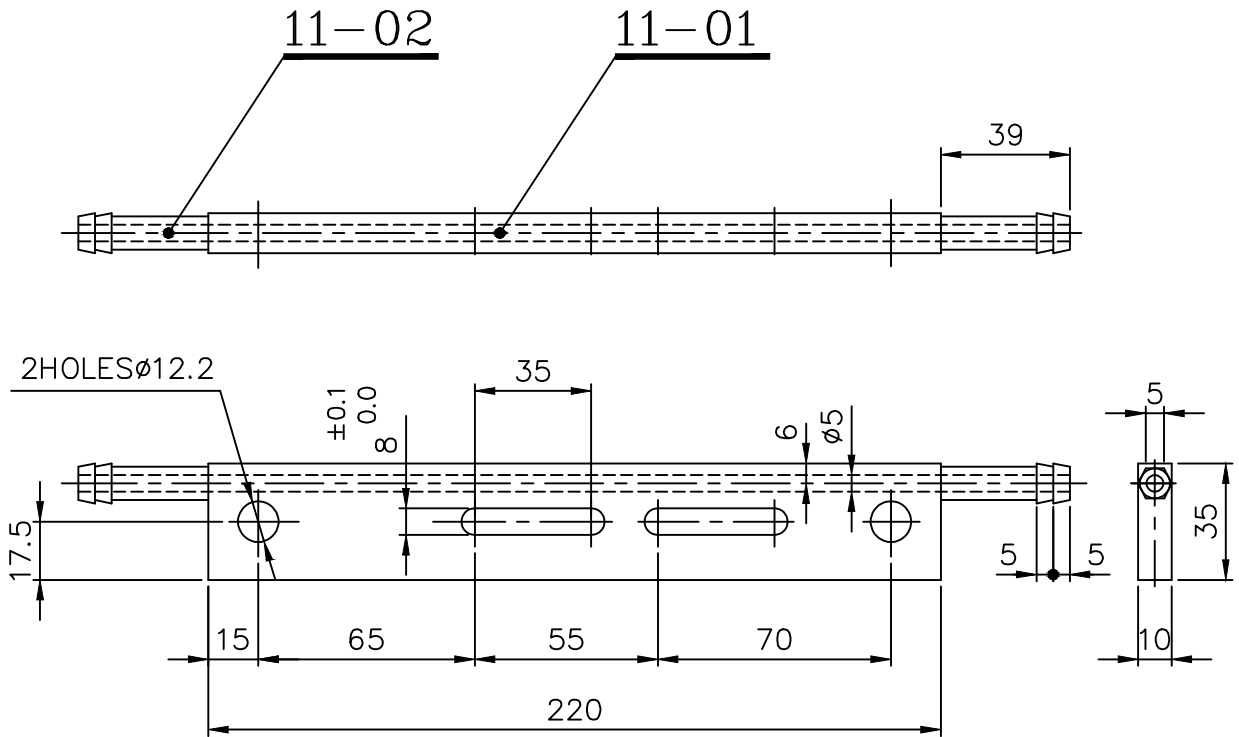

NOTE: -

REMOVE ALL SHARP CORNERS

TO BE SOLDERED WITH SILFOS

② GRADE OF UNTOL.DIM IS: 2102 (MEDIUM)

02	∅12x39	CuZn39Pb3	ASTM 455 C 38500			02
01	10x35x220	CuZn39Pb3	ASTM 455 C 38500			01
X					2M12A1804365 2M12A2404810 2M12A2304808 2M12A1804914	11
No. of Pieces	DESCRIPTION	MATERIAL	STANDARD	NET.WT.IN KGS.	DRAWING No.	ITEM No.
	REFERENCE:	ALTERATIONS:		DCN REF	DATE	SIGN.
SCALE	DRAWN/TC'D	S.selvamanickam	MATERIAL CHANGED		17.02.10	CSJ
1:2	CHECKED	R.RAMAMOORTHY	TOLERANCE STANDARED ADDED		05.08.20	NMV
	APPROVED	C.S.JAYASHEELAN				
	DATE	24.10.2000/17.02.10'				
	MACHINE: INCREMENTAL PIPE BENDER	TYPE: PB 1200R				
	TITLE:	DRAWING No:				REV.
	STRIP	4M12A182666402				
	Sheet No:	No. of Sheets:				

Annexure: Inductor Assembly Spare Parts Drawings

ITEM 3: Mica Insulation Ring 1

Specification: OD: 30 mm x ID: 16.2 +/- 0.2 mm x Thick: 3 mm

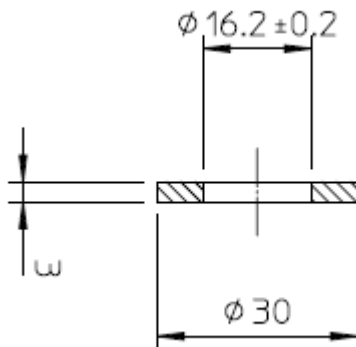

ITEM 4: Mica Insulation Ring 2

Specification: OD: 20 mm x ID: 10.2 +/- 0.2 mm x Thick: 2 mm

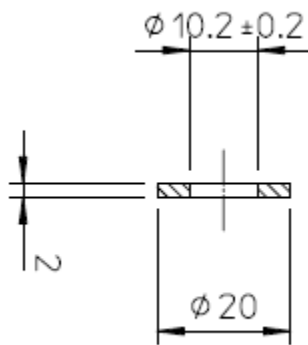

ITEM 5: Mica Insulation Bush 1

Specification: OD: 16 +/- 0.3 mm x ID: 12.2 +/- 0.2 mm x Length: 20 +/- 0.3 mm

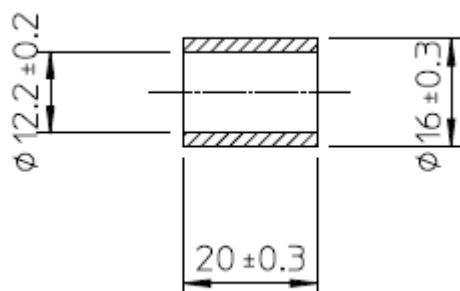

Annexure: Inductor Assembly Spare Parts Drawings

ITEM 6: Mica Insulation Bush 2

Specification: OD: 16 +/- 0.3 mm x ID: 12.2 +/- 0.2 mm x Length: 11 +/- 0.3 mm

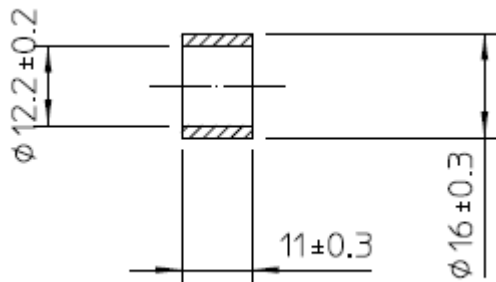

ITEM 7: Mica Insulation Bush 3

Specification: OD: 14 mm x ID: 10 mm x Length: 20 mm

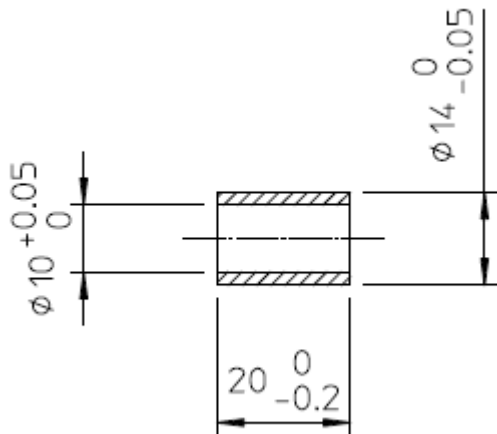

ITEM 8: Mica Insulation Bush 4

Specification: OD: 21 mm x ID: 6 mm x Length: 16 mm

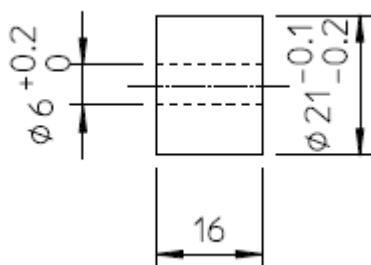

Annexure: Inductor Assembly Spare Parts Drawings

ITEM 9: Strip as per drawing 1

Material : AISI 316

Weight : 0.4kg

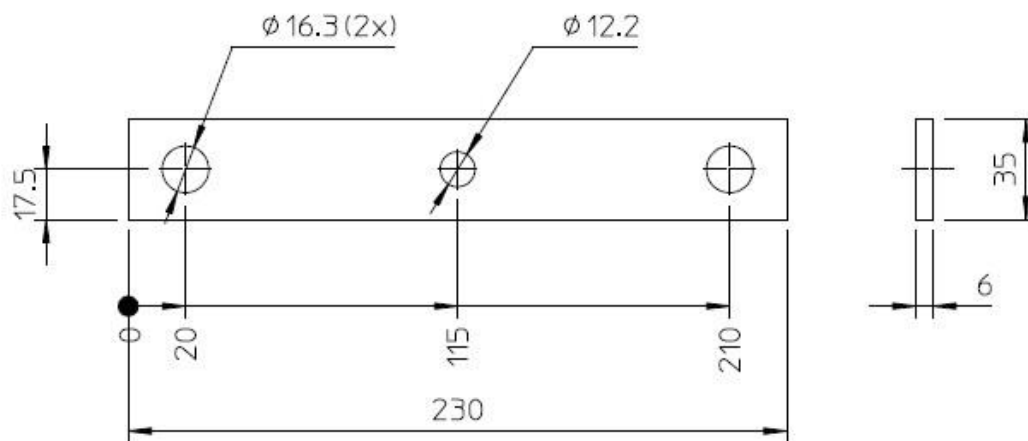

Drawing 1: Strip

Annexure: Inductor Assembly Spare Parts Drawings

ITEM 10: Strip as per drawing 2

Material: CuZn40Pb3

Weight : 0.7kg

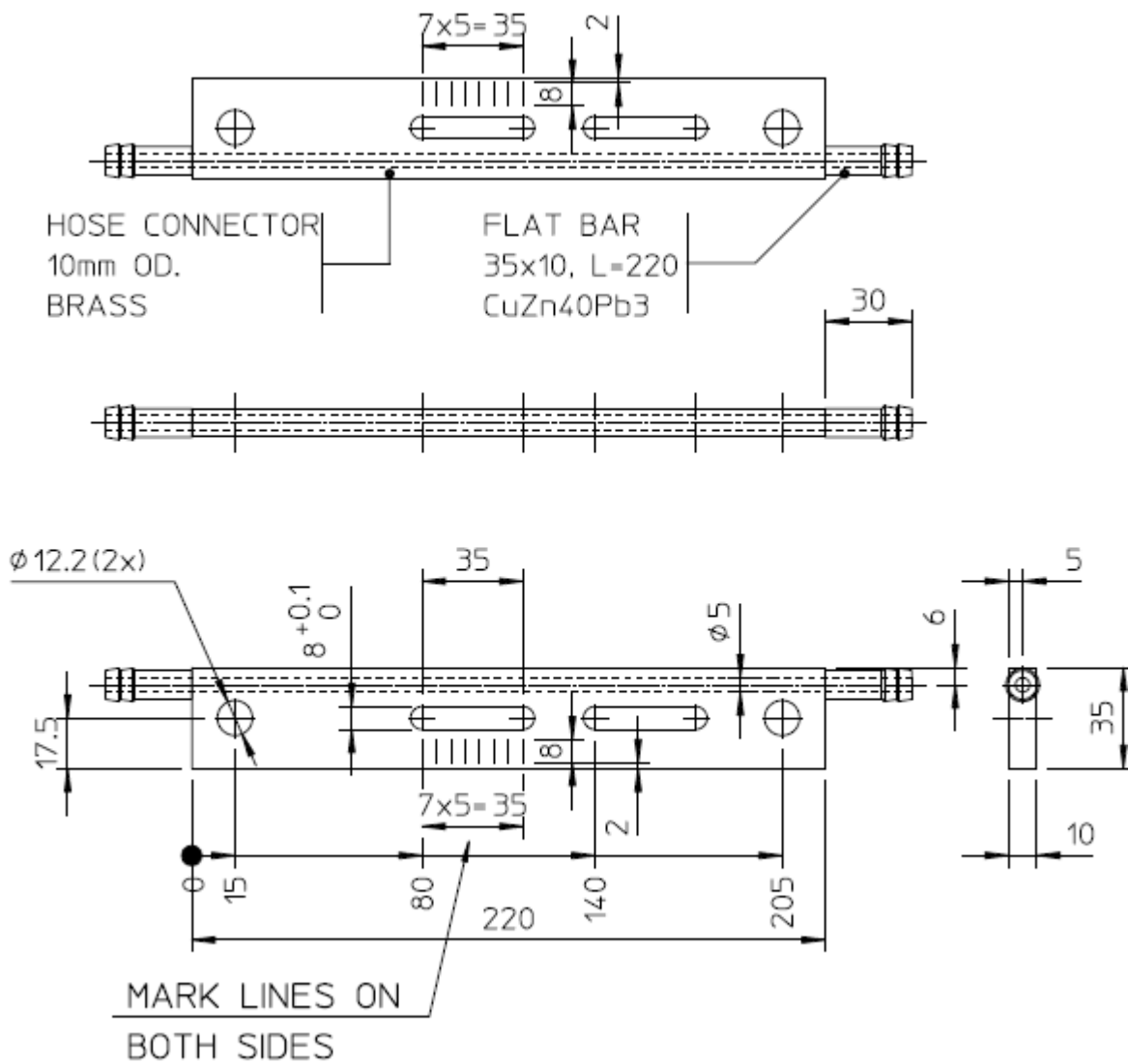

Drawing 2:Strip

Annexure: Inductor Assembly Spare Parts Drawings

ITEM 11: Block as per drawing 3

BLOCK - SQUARE BAR:

Material: CuZn39Pb3

Weight :0.1kg

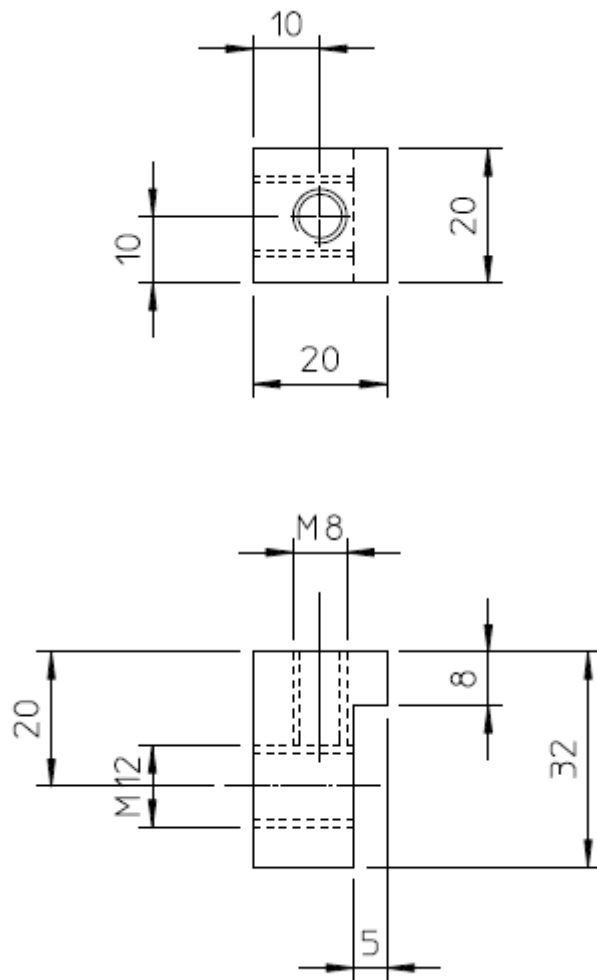

Drawing 3: Block Square Bar

Annexure: Inductor Assembly Spare Parts Drawings

ITEM 14: Pivot Block as per drawing 5

Pivot Block - Square Bar:

Material : CuZn39Pb3

Weight : 0.3kg

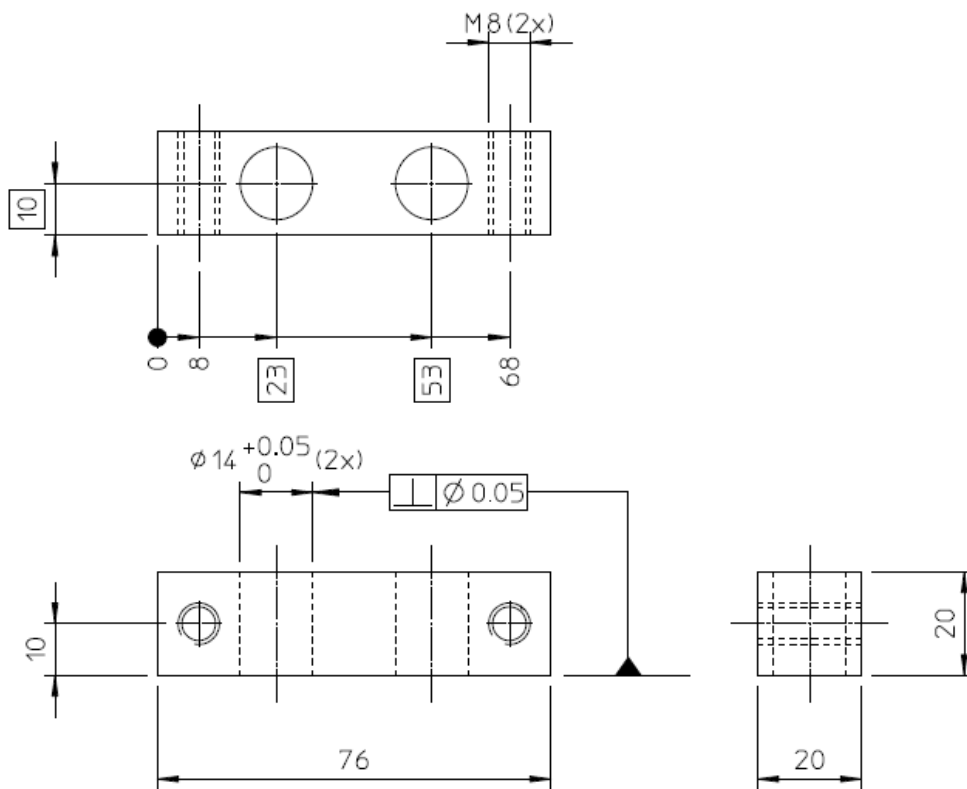

NOTES:

TO BE SOLDERED WITH SILFOS

REMOVE SHARP EDGES

ALL HOLES: $\phi \phi 0.2$

Drawing 5: Pivot Block Square Bar

Annexure – A- Special Conditions for GeM Enquiry

The terms and condition mentioned in this document are applicable in addition to the Buyer Added Bid Specific Additional Terms & Conditions and GeM General Terms and Conditions. Bidders shall furnish pointwise confirmation/details.

<u>To be filled by bidder</u>				
Description of the item/Equipment:				
GeM Tender No. & Date				
Name of the firm (Bidder)		:		
Address		:		
<u>Contact person 1</u>		<u>Contact person 2</u>		
Name:		Name:		
Designation:		Designation:		
Office Phone:		Office Phone:		
Mobile:		Mobile:		
e-mail:		e-mail:		
Sl	Terms and conditions/Details required			Vendor's confirmation
1.	Indicate the MSME status of the bidder. MICRO/SMALL/MEDIUM/Non-MSME (Udyam certificate is to be uploaded in proof of above).			
2.	Any Bidder falling under MSE category shall furnish the following details & submit documentary evidence/ Govt. Certificate etc. in support of the same along with their offer.			
	Type under MSE	SC/ST Owned	Women Owned	Others (excluding SC/ST & Women Owned)
	Micro			
	SMALL			
	Note: If the bidder does not furnish the above in the tender, offer shall be processed construing that the bidder is not falling under MSE category.			
3.	Payment terms shall be as per clause 9 of Buyer Added Bid Specific Additional Terms & Conditions for this tender. Confirm your acceptance for the payment terms relevance to your MSME status indicated above. Note: If it is indicated as "For availing benefits of Priority Sector Lending(PSL) ONLY" in Udyam certificate, then no MSME benefit will be considered for this tender.			
4.	Liquidated Damages shall be as per clause 18 of Buyer Added Bid Specific Additional Terms & Conditions. Confirm your acceptance.			

5.	Offers from Indigenous supplier will be considered only if they have a valid GST registration certificate. Please Indicate the GST registration number. If any specific exemption is available, a declaration with due supporting documents need to be furnished for considering the offer.	GST No. _____
6.	Performance Bank Guarantee: Not Applicable	
7.	HSN Code for the quoted items	HSN CODE : _____
8.	Rate quoted in GeM portal should be on FOR destination basis inclusive of all taxes, P&F, freight etc. Transit Insurance is under Supplier scope. Please indicate how much GST percentage is included in quoted price.	GST in %: _____
9.	Technical (Specification, brand, etc.) and commercial terms agreed against BHEL clarifications during the techno-commercial evaluation stage should also be honoured by the bidder, even if they aren't explicitly part of the final GeM contract. The rationale behind this is that such agreements influence the final decision and are not captured by GeM in to the GeM contract. Please confirm your acceptance.	
10.	All the terms and conditions in Buyer Added Bid Specific Additional Terms & Conditions of this tender are read, understood and agreed by the vendor without any deviation. Vendor to confirm.	
11.	Duly filled, signed and stamped copies of the annexures as indicated in clause 31 of Buyer Added Bid Specific Additional Terms & Conditions of the enquiry are to be provided in the letter head of the Supplier. Please fill the annexures with GeM enquiry number, Item description and your company name wherever required. Also please Tick the appropriate option wherever required.	
12.	There will not be any RA (Reverse Auction). Hence suppliers to quote their best price while submitting their offer itself.	

Vendor's Seal & Signature

CHECK LIST

NOTE: - Suppliers are required to fill in the following details in their Letterhead and no column should be left blank

A	Name and Address of the Supplier		
B	GSTN No. the Supplier (Place of Execution of Contract / Purchase Order)		
C	Details of Contact person for this Tender	Name: Mr./ Ms. Designation: Telephone No: Mobile No: Email ID:	
D	EMD DETAILS	Not applicable	
E	DESCRIPTION	APPLICABILITY (BY BHEL)	ENCLOSED BY BIDDER
i.	Whether Pre - Qualification Criteria is understood and provided proper supporting documents.	Applicable/ Not Applicable	YES / NO
ii.	Whether all pages of the Tender documents including annexures, appendices etc are read and understood	Applicable/ Not Applicable	YES / NO
iii.	Audited Balance Sheet and profit & Loss Account for the last three years	Applicable/ Not Applicable	YES / NO
iv.	Copy of PAN Card & GST registration	Applicable/ Not Applicable	YES / NO
v.	Submission of Udyam certificate as specified in Tender (applicable in case of MSME supplier)	Applicable/ Not Applicable	YES / NO
vi.	Offer forwarding letter / tender submission letter as per Annexure – 2	Applicable/ Not Applicable	YES / NO
vii.	Submission of Certificate of No Deviation as per Annexure – 3	Applicable/ Not Applicable	YES / NO
viii.	Declaration regarding Insolvency/ Liquidation/ Bankruptcy Proceedings as per Annexure – 4	Applicable/ Not Applicable	YES / NO
ix.	Declaration by Authorized Signatory as per Annexure – 5	Applicable/ Not Applicable	YES / NO
x.	Declaration by Authorized Signatory regarding Authenticity of submitted Documents Annexure – 6	Applicable/ Not Applicable	YES / NO
xi.	Submission of Non-Disclosure Certificate as per Annexure – 7	Applicable/ Not Applicable	YES / NO
xii.	Submission of Integrity Pact as specified in Tender as per Annexure – 8	Applicable/ Not Applicable	YES / NO
xiii.	Declaration confirming knowledge about Site Conditions as per Annexure – 9	Applicable/ Not Applicable	YES / NO

xiv.	Declaration reg. Related Firms & their areas of Activities as per Annexure – 10	Applicable/ Not Applicable	YES / NO
xv.	Declaration for relation in BHEL as per Annexure – 11	Applicable/ Not Applicable	YES / NO
xvi.	Declaration reg. minimum local content in line with revised public procurement as per Annexure – 12	Applicable/ Not Applicable	YES / NO
xvii.	Declaration regarding compliance to Restrictions under Rule 144 (xi) of GFR 2017 as per Annexure – 13	Applicable/ Not Applicable	YES / NO
xviii.	Bank Account Details for E-Payment as per Annexure – 14	Applicable/ Not Applicable	YES / NO
xix.	Power of Attorney for submission of tender as per Annexure – 15	Applicable/ Not Applicable	YES / NO
xx.	Proforma of Bank Guarantee for Earnest Money as per Annexure – 16	Applicable/ Not Applicable	YES / NO
xxi.	Treatment of cases regarding conflict of interest as per Annexure – 20	Applicable/ Not Applicable	YES / NO

NOTE: Strike off 'YES' or 'NO', as applicable. Tender not accompanied by the prescribed **above applicable documents** are liable to be summarily rejected.

DATE:

**Sign. of the AUTHORISED SIGNATORY
(With Name, Designation and Company seal)**

CERTIFICATE OF NO DEVIATION

(To be Typed & submitted in the Letter Head of the Company/Firm of Bidder)

To,

(Write Name & Address of Officer of BHEL inviting the Tender)

Dear Sir,

Subject: **No Deviation Certificate**

Ref: 1) GeM Bid No:

2) All other pertinent issues till date

We hereby confirm that we have not changed/ modified/materially altered any of the tender documents as downloaded from the website/ issued by BHEL and in case of such observance at any stage, it shall be treated as null and void.

We also hereby confirm that we have neither set any Terms and Conditions and nor have we taken any deviation from the Tender conditions together with other references applicable for the above referred GeM Bid.

We further confirm our unqualified acceptance to all Terms and Conditions, unqualified compliance to Tender Conditions.

We confirm to have submitted offer in accordance with tender instructions and as per aforesaid references.

Thanking you,

Yours faithfully,

**(Signature, date & seal of
authorized representative of the
bidder)**

Date:

Place:

UNDERTAKING

(To be typed and submitted in the Letter Head of the Company/Firm of Bidder)

To,

(Write Name & Address of Officer of BHEL inviting the Tender)

Dear Sir/Madam,

Sub: DECLARATION REGARDING INSOLVENCY/ LIQUIDATION/ BANKRUPTCY PROCEEDINGS

Ref: GeM Bid Specification No:

I/We, _____ declare that, I/We am/are not admitted under insolvency resolution process or liquidation under Insolvency and Bankruptcy Code, 2016, as amended from time to time or under any other law as on date, by NCLT or any adjudicating authority/authorities

**Sign. of the AUTHORISED SIGNATORY
(With Name, Designation and Company seal)**

Place:

Date:

DECLARATION BY AUTHORISED SIGNATORY OF BIDDER

(To be typed and submitted in the Letter Head of the Company/Firm of Bidder)

To,

(Write Name & Address of Officer of BHEL inviting the Tender)

Dear Sir,

Sub: **Declaration by Authorised Signatory regarding Authenticity of submitted documents.**

Ref: 1) GeM Bid No. & Date:

2) All other pertinent issues till date

I/We, hereby certify that all the documents submitted by us in support of possession of "Qualifying Requirements" are true copies of the original and are fully compliant required for qualifying / applying in the bid and shall produce the original of same as and when required by Bharat Heavy Electricals Limited.

I / We hereby further confirm that no tampering is done with documents submitted in support of our qualification as bidder. I / We understand that at any stage (during bidding process or while executing the awarded contract) if it is found that fake / false / forged bid qualifying / supporting documents / certificates were submitted, it would lead to summarily rejection of our bid / termination of contract. BHEL shall be at liberty to initiate other appropriate actions as per the terms of the Bid / Contract and other extant policies of Bharat Heavy Electricals Limited.

Yours faithfully,

(Signature, Date & Seal of Authorized Signatory of the Bidder)

Date:

NON-DISCLOSURE CERTIFICATE

(To be Typed & submitted in the Letter Head of the Company/Firm of Bidder)

I/We understand that BHEL, Trichy is committed to Information Security Management System as per their Information Security Policy.

Hence, I/We M/s who are submitting offer for providing Supply/services to BHEL, Trichy against GeM Bid No..... hereby undertake to comply with the following in line with Information Security Policy of BHEL, Trichy.

- To maintain confidentiality of documents & information which shall be used during the execution of the Contract.
- The documents & information shall not be revealed to or shared with third party which shall not be in the business interest of BHEL, Trichy.

(Signature, date & seal of Authorized Signatory of the bidder)

Date:

DECLARATION

Date: _____

To,

(Write Name & Address of Officer of BHEL inviting the Tender)

Dear Sir/ Madam,

Sub: Details of related firms and their area of activities

Please find below details of firms owned by our family members that are doing business/ registered for same item with BHEL, _____ (NA, if not applicable)

1	Material Category/ Work Description	
	Name of Firm	
	Address of Firm	
	Nature of Business	
	Name of Family Member	
	Relationship	
2	Material Category/ Work Description	
	Name of Firm	
	Address of Firm	
	Nature of Business	
	Name of Family Member	
	Relationship	
...		

Note: I certify that the above information is true and I agree for penal action from BHEL in case any of the above information furnished is found to be false.

Regards,

(_____)

From: M/s

Supplier

Code:

Address:

DECLARATION FOR RELATION IN BHEL

(To be typed and submitted in the Letter Head of the Company/Firm of Bidder failing which the offer of Bidder is liable to be summarily rejected)

To,

(Write Name & Address of Officer of BHEL inviting the Tender)

Dear Sir,

Sub: Declaration for relation in BHEL

Ref: 1) GeM Bid Specification No:

I/We hereby submit the following information pertaining to relation/relatives of Proprietor/Partner(s)/ Director(s) employed in BHEL

Tick (✓) any one as applicable:

1. The Proprietor, Partner(s), Director(s) of our Company/Firm DO NOT have any relation or relatives employed in BHEL

OR

2. The Proprietor, Partner(s), or Director(s) of our Company/Firm HAVE relation/relatives employed in BHEL and their particulars are as below:

i.

ii.

**(Signature, Date & Seal of
Authorized Signatory of the Bidder)**

Note:

1. Attach separate sheet, if necessary.
2. If BHEL Management comes to know at a later date that the information furnished by the Bidder is false, BHEL reserves the right to take suitable against the Bidder/Contractor.

**DECLARATION REGARDING MINIMUM LOCAL CONTENT IN LINE WITH
REVISED PUBLIC PROCUREMENT (PREFERENCE TO MAKE IN INDIA), ORDER
2017 DATED 04TH**

JUNE, 2020 AND SUBSEQUENT ORDER(S)

(To be typed and submitted in the Letter Head of the Entity/Firm providing certificate as applicable)

To,

(Write Name & Address of Officer of BHEL inviting the Tender)

Dear Sir,

Sub: Declaration reg. minimum local content in line with Public Procurement (Preference to Make in India), Order 2017-Revision, dated 04th June, 2020 and subsequent order(s).

Ref: 1) GeM Bid Specification No:

2) All other pertinent issues till date

We hereby certify that the items/works/services offered by.....
(specify the name of the organization here) has a local content of _____ % and this meets the local content requirement for '**Class-I local supplier**' / '**Class II local supplier**' ** as defined in Public Procurement (Preference to Make in India), Order 2017-Revision dated 04.06.2020 issued by DPIIT and subsequent order(s).

The details of the location(s) at which the local value addition is made are as follows:

- | | |
|----------|----------|
| 1. _____ | 2. _____ |
| 3. _____ | 4. _____ |

Thanking you,
Yours faithfully,

**(Signature, Date & Seal of
Authorized Signatory of the
Bidder)**

** - Strike out whichever is not applicable.

Note:

1. Bidders to note that above format, duly filled & signed by authorized signatory, shall be submitted along with the techno-commercial offer.
2. In case the bidder's quoted value is in excess of Rs. 10 crores, the authorized signatory for this declaration shall necessarily be the statutory auditor or cost auditor of the company (in the case of companies) or a practising cost accountant or practicing chartered accountant (in respect of suppliers other than companies).
3. In the event of false declaration, actions as per the above order and as per BHEL Guidelines shall be initiated against the bidder.

DECLARATION REGARDING COMPLIANCE TO RESTRICTIONS UNDER RULE 144 (xi) OF GFR 2017

(To be typed and submitted in the Letter Head of the Entity/ Firm providing certificate as applicable)

To,

(Write Name & Address of Officer of BHEL inviting the Tender)

Dear Sir,

Sub: Declaration regarding compliance to Restrictions under Rule 144 (xi) of GFR 2017

Ref: 1) GeM Bid Specification No:
2) All other pertinent issues till date

I have read the clause regarding restrictions on procurement from a bidder of a country which shares a land border with India. I certify that _____ (**SPECIFY THE NAME OF THE ORGANIZATION HERE**), is not from such a country/ has been registered with the Competent Authority (*attach valid registration by the Competent Authority, i.e., the Registration Committee constituted by the Dept. for Promotion of Industry and Internal Trade (DPIIT)*).

I hereby certify that we fulfil all requirements in this regard and is eligible to be considered.

Thanking you,

Yours faithfully,

**(Signature, Date & Seal of
Authorized Signatory of the Bidder)**

Note: Bidders to note that in case above certification given by a bidder, whose bid is accepted, is found to be false, then this would be a ground for immediate termination and for taking further action in accordance with law and as per BHEL guidelines.

TREATMENT OF CASES REGARDING CONFLICT OF INTEREST

The bidder notes that a conflict of interest would said to have occurred in the tender process and execution of the resultant contract, in case of any of the following situations:

- i) If its personnel have a close personal, financial, or business relationship with any personnel of BHEL who are directly or indirectly related to the procurement or execution process of the contract, which can affect the decision of BHEL directly or indirectly;
- ii) The bidder (or his allied firm) provided services for the need assessment/ procurement planning of the Tender process in which it is participating;
- iii) Procurement of goods directly from the manufacturers/ suppliers shall be preferred. However, if the OEM/Principal insists on engaging the services of an agent, such agent shall not be allowed to represent more than one manufacturer/ supplier in the same tender. Moreover, either the agent could bid on behalf of the manufacturer/ supplier or the manufacturer/ supplier could bid directly but not both. In case bids are received from both the manufacturer/ supplier and the agent, bid received from the agent shall be ignored. However, this shall not debar more than one Authorised distributor (with/ or without the OEM) from quoting equipment manufactured by an Original Equipment Manufacturer (OEM) in procurements under a Proprietary Article Certificate.
- iv) A bidder participates in more than one bid in this tender process. Participation in any capacity by a Bidder (including the participation of a Bidder as a partner/ JV member or sub-contractor in another bid or vice-versa) in more than one bid shall result in the disqualification of all bids in which he is a party. However, this does not limit the participation of an entity as a sub-contractor in more than one bid if he is not bidding independently in his own name or as a member of a JV.

The Bidder declares that they have read and understood the above aspects, and the bidder confirms that such conflict of interest does not exist and undertakes that they will not enter into any illegal or undisclosed agreement or understanding, whether formal or informal with other Bidder(s), in this regard. This applies in particular to prices, specifications, certifications, subsidiary contracts, submission or non-submission of bids or any other actions to restrict competitiveness or to introduce cartelization in the bidding process. **In case, the Bidder is found having indulged in above activities, the same will be considered as a violation of the tender conditions, and suitable action shall be taken by BHEL as per extant policies/ guidelines.**

(Signature, Date & Seal of Authorized
Signatory of the Bidder)