

Technical Specifications

SL. No	Description and Technical Specification of the item	QTY	UNIT	Delivery
1	<p><u>MALE CABLE CONNECTOR</u></p> <p>Male welding cable connector (in assembled condition) for 600 Ampere as per Drawing Number 3M-10A-4313322/04 and Test certificate is required along with supply.</p> <p>Application-In welding industry.</p>	1,000	NO	60 DAYS
2	<p><u>FEMALE CABLE CONNECTOR</u></p> <p>Female welding cable connector (in assembled condition) for 600 Ampere as per Drawing Number 3M-10A-4313322/04 and Test certificate is required along with supply.</p> <p>Application-In welding industry.</p>	1,000	NO	60 DAYS
3	<p><u>ITEM NO 07 HYLUM PIN</u></p> <p>ITEM NO 07 (HYLUM PIN) as per Drawing Number 3M-10A-4313322/04.</p> <p>Application-In welding industry.</p>	3,000	NO	60 DAYS
4	<p><u>ELECTRODE HOLDER 600 AMPS</u></p> <ol style="list-style-type: none"> 1. Electrode Holder (Fully insulated) for rated current 600 amperes at 35 % Duty Cycle as per IS 2641: 1989 (latest) or relevant standard. 2. Electrode holder is suitable for electrode diameter 2.4 mm to 6.3 mm. 3. Electrode Holder Jaw - Open Type. 4. Maximum Distance between the Handle (Lower portion) and lever (top surface) shall be 85 mm maximum. Refer the Schematic diagram of electrode holder. 5. Weight of electrode holder - Maximum 600 grams. 6. Electrode holder has "ball point connection for clamping welding cable" or "cable connection by brass nut and conical pin connecting method". One Allen key is supplied along with each electrode holder in case of ball connection. 	600	NO	60 DAYS

	<p>7. Electrode holder shall permit following point.</p> <p>7.1. The safe and rapid fitting of electrodes and release of stub ends.</p> <p>7.2. The design of the electrode holders shall be such that under normal conditions of service, it shall be possible to weld with electrodes in any position in the holder until a stub of only 40 mm in length remains without damage to the holder.</p> <p>7.3. The electrode to be pulled off the work piece in the event of unwanted sticking to the work piece.</p> <p>7.4. The clamping of all electrode diameters as specified (from diameter 2.4 mm to 6.3 mm) without pressure being exerted by the operator.</p> <p>7.5. Electrode holder is suitable for 35 square mm welding cable and 50 square mm welding cable.</p> <p>7.6. Electrode holder spring force such as it is, electrode holder lever is effortlessly compressed and simultaneously it shall hold Welding electrodes properly during welding process.</p> <p>7.7. Electrode holders shall have the provision for alternative positions for gripping electrodes to avoid the necessity for bending the electrodes when welding in different positions.</p> <p>7.8. Electrode holder handle shall have proper gripping.</p> <p>8. Electrode holder test certificate as per relevant standard is required along with supply.</p>			
5	<p><u>ELECTRODE HOLDER ASSEMBLY (As per drg. 400A)</u></p> <p>Electrode Holder 400 Amperes (FULLY INSULATED) as per Drawing number 3M-10A43-12947 TO 12950 and as per Drawing number 4M-10A43-28059 TO 28064. Material Test Certificate is Required Along with Supply.</p> <p>Application - SMAW Welding Process.</p> <p>Jaw hole is blind hole in drawing number 3M-10A43-12948 and 3M-10A43-12949.</p> <p>Electrode holder shall permit safe and rapid fitting of electrodes and release of stub ends. Electrode holder spring force such as it is, electrode holder lever is effortlessly compressed by welder and simultaneously it shall hold welding electrodes properly during welding process.</p>	1,500	NO	60 DAYS

6	<u>Earth clamp and Handle for 600 Amperes.</u> Earth Clamp and handle for 600 Amperes as per BHEL's drawing number 4M-10A43-25046/01. With full tightening of handle during and after clamping, no visible crack is permitted in the earth clamp surface. Earth clamp and handle shall be smooth and free of burrs.	1,000	NO	60 DAYS
---	--	-------	----	---------

Important Note:

Item SI no. 1,2 & 3 - Package basis.

Item 4 - item wise.

Item 5 - item wise.

Item 6 - item wise.

CAUTION: THIS DRAWING IS OUR SOLE PROPERTY AND SHOULD NOT BE USED IN ANY FORM FOR ANY PURPOSES WITHOUT THE WRITTEN PERMISSION OF BHARAT HEAVY ELECTRICALS LIMITED TRICHYRAPPALLI - 620 014.

ALL DIMENSIONS ARE IN MM

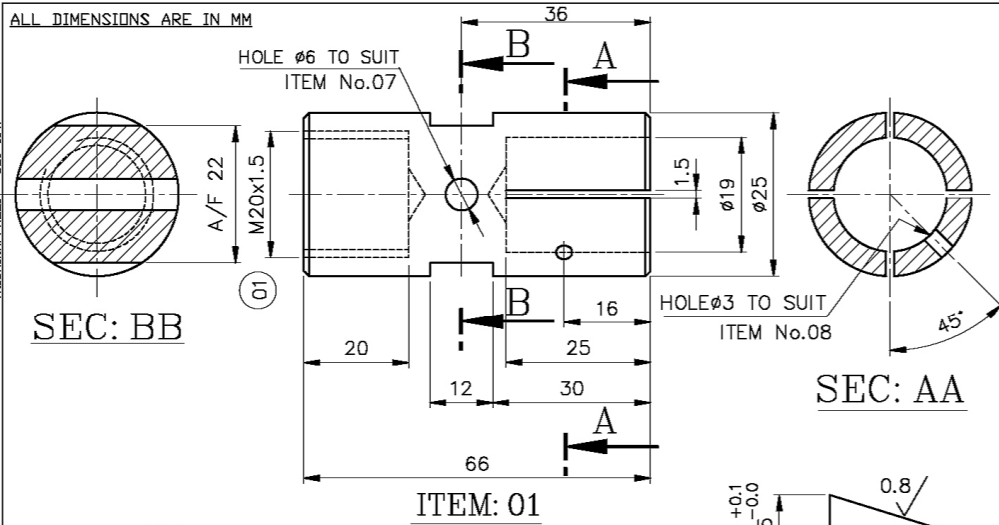

SEC: BB

SEC: AA

ITEM: 01

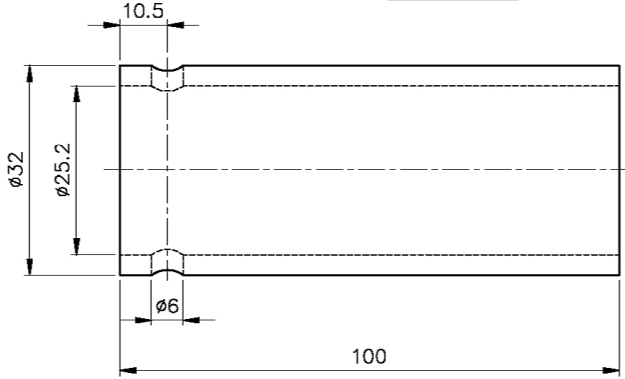

ITEM: 04

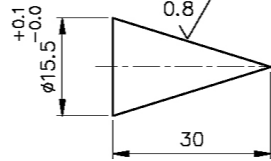

ITEM: 05

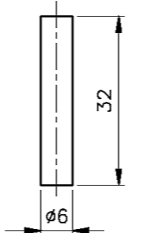

ITEM: 07

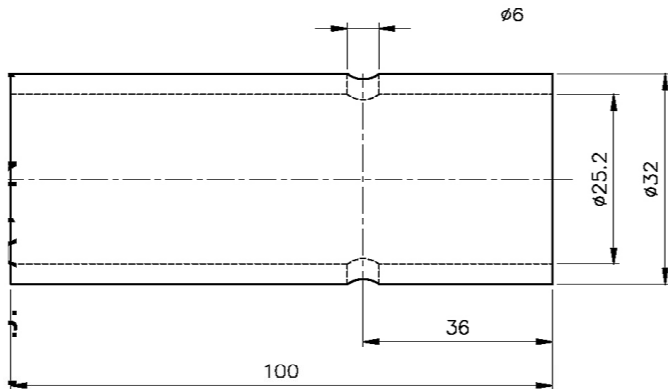

ITEM: 02

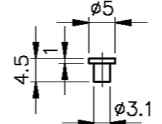

ITEM: 08

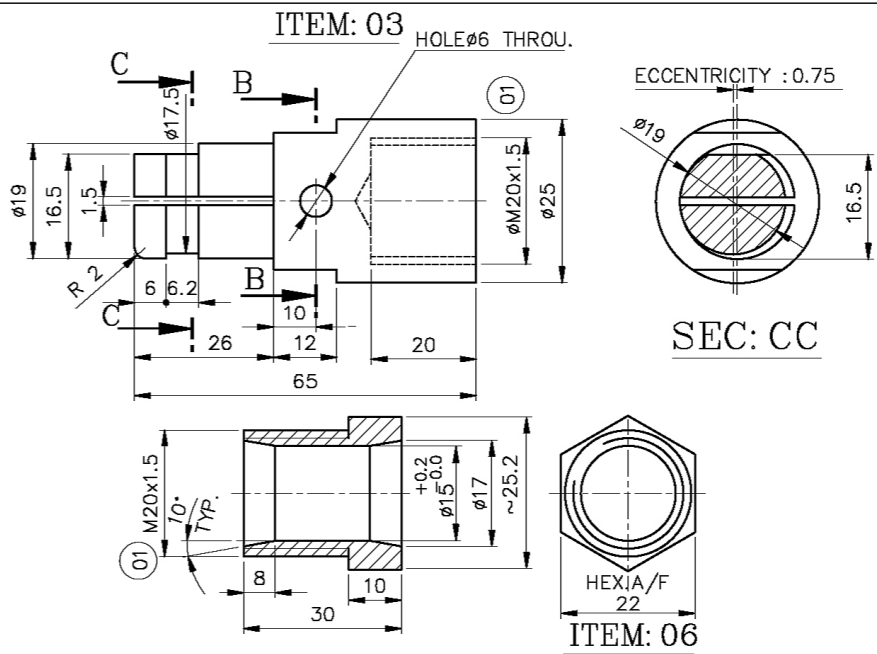

SEC: CC

ITEM: 06

FEMALE CONNECTOR → ① + ② + ⑤ + ⑥ + ⑦ + ⑧ IN ASSEMBLED CONDITION

MALE CONNECTOR → ③ + ④ + ⑤ + ⑥ + ⑦ IN ASSEMBLED CONDITION

③ MALE & FEMALE CONNECTOR SHALL HAVE PROPER FITTING TO GRIP THE WELDING CABLE IN TIGHT CONDITION.

No. of Pieces	DESCRIPTION	MATERIAL	STANDARD	DRAWING No.	ITEM No.
1	RIVET	30 C8	IS:1875:1992 (LATEST)		08
2	PIN $\phi 6 \times 32$ L	FRP-FIBRE REINFORCED PLASTIC			07
2	HEX.NUT M20x1.5x30 L	CU.Zn.40	IS: 4170:1967 (LATEST)		06
2	TAPER PLUG	CU.Zn.40	IS: 4170:1967 (LATEST)		05
1	HANDLE	FRP-FIBRE REINFORCED PLASTIC			04
1	PLUG (MALE CONNECTOR)	CU.Zn.40	IS: 4170:1967 (LATEST)		03
1	HANDLE	FRP-FIBRE REINFORCED PLASTIC			02
1	SOCKET (FEMALE CONNECTOR)	CU.Zn.40	IS: 4170:1967 (LATEST)		01

SCALE	DRAWN/TCD	P.A.ROSS.	ITEM NO.08 IS:1875:1992 (LATEST) WAS 30 C8 IS: 7283	DATE	SIGN.	INDEX
1:1	CHECKED	R.RAMAMOORTHY	ITEM NO.01,03,05,06 IS: 4170:1967 (LATEST) WAS CU.Zn.42 Pb.2 IS: 3488	26.10.09	CSJ	①
	APPROVED	C.S.JAYASHEELAN	MATERIAL HYLAM WAS HEAT RESISTANT UNBREAKABLE INSULATOR FOR IT.2.4&7	28/06/16	CAP	③
	DATE	27-08-93/26-10-09	HYLAM MATERIAL CHANGED TO FRP - FIBER REINFORCED PLASTIC	17/03/21	CAP	④

MACHINE	WELDING ACESERIES	TYPE	WTC

TITLE	DRAWING No	Sheet No	No. of Sheets
CABLE CONNECTOR (600 AMPS)	3M10A431332204		

CAUTION: THIS DRAWING IS OUR SOLE PROPERTY AND SHOULD NOT BE USED IN ANY FORM FOR ANY PURPOSE WITHOUT THE WRITTEN PERMISSION OF BHARAT HEAVY ELECTRICALS LIMITED TRICHIRAPPALLI - 620 014.

ALL DIMENSIONS ARE IN MM

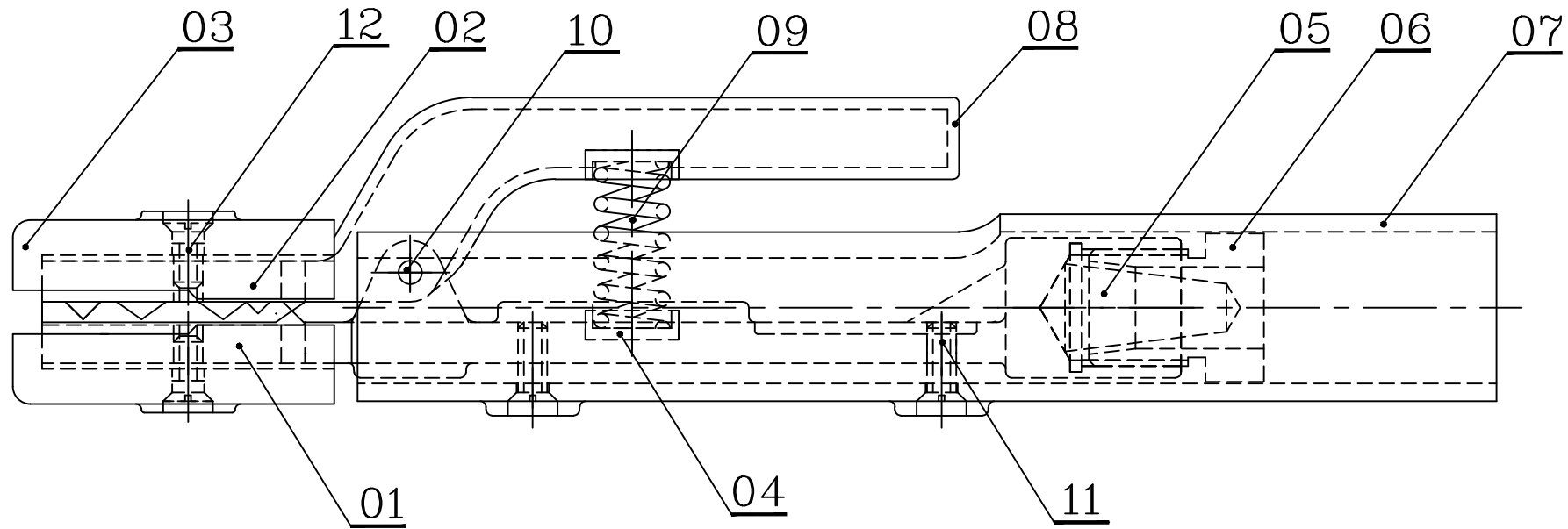

2	CSK HD.SCREW M5x12L	A8M	IS 617			12
2	CSK HD.SCREW M5x10L	A8M	IS 617			11
1	PIN ϕ 4x20L	45C8	IS: 7283			10
1	COMP.SPRING	50 Cr 4 V2	IS 2507	4-M-10A43-28063		09
1	HANDLE INSULATION	HEAT RESISTANCE UNBREAKABLE FIBRE		4-M-10A43-28062		08
1	HOLDER COVER	HEAT RESISTANCE UNBREAKABLE FIBRE		3-M-10A43-12950		07

1	HEX.NUT-M20x2	FNB	IS: 6912		4-M-10A43-28061	06	
1	TAPER PLUG	FNB	IS: 6912		4-M-10A43-28060	05	
2	SPRING RETAINER	BAKELITE			4-M-10A43-28059	04	
2	JAW COVER	HEAT RESISTANCE UNBREAKABLE FIBRE			4-M-10A43-28064	03	
1	TOP JAW	FNB	IS: 6912		3-M-10A43-12949	02	
1	BOTTOM JAW	FNB	IS: 6912		3-M-10A43-12948	01	
				0.575			
No. of Pieces		DESCRIPTION	MATERIAL	STANDARD	NET.WT.IN KGS.	DRAWING No.	ITEM No.
		REFERENCE:	ALTERATIONS:		DCN REF	DATE	SIGN.
SCALE	DRAWN	G.G.R					
/	CHECKED	R.RAMAMOORTHY					
	APPROVED	C.S.JAYASHEELAN					
	DATE	20-09-07					
MACHINE: WELDING ACCESSORIES				TYPE: WTC			
TITLE: SMAW ELECTRODE HOLDER WITH MODIFIED HANDLE FOR NARROW GAP WELDING 400 AMPS (FULLY INSULATED)				DRAWING No:		REV.	
				3M10A4312947			
				Sheet No:		No. of Sheets:	

CAUTION: THIS DRAWING IS OUR SOLE PROPERTY AND SHOULD NOT BE USED IN ANY FORM FOR ANY PURPOSE WITHOUT THE WRITTEN PERMISSION OF BHARAT HEAVY ELECTRICALS LIMITED TRICHIRAPPALLI - 620 014.

ALL DIMENSIONS ARE IN MM

3.2/

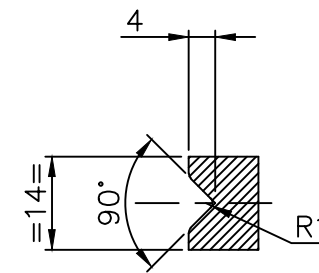
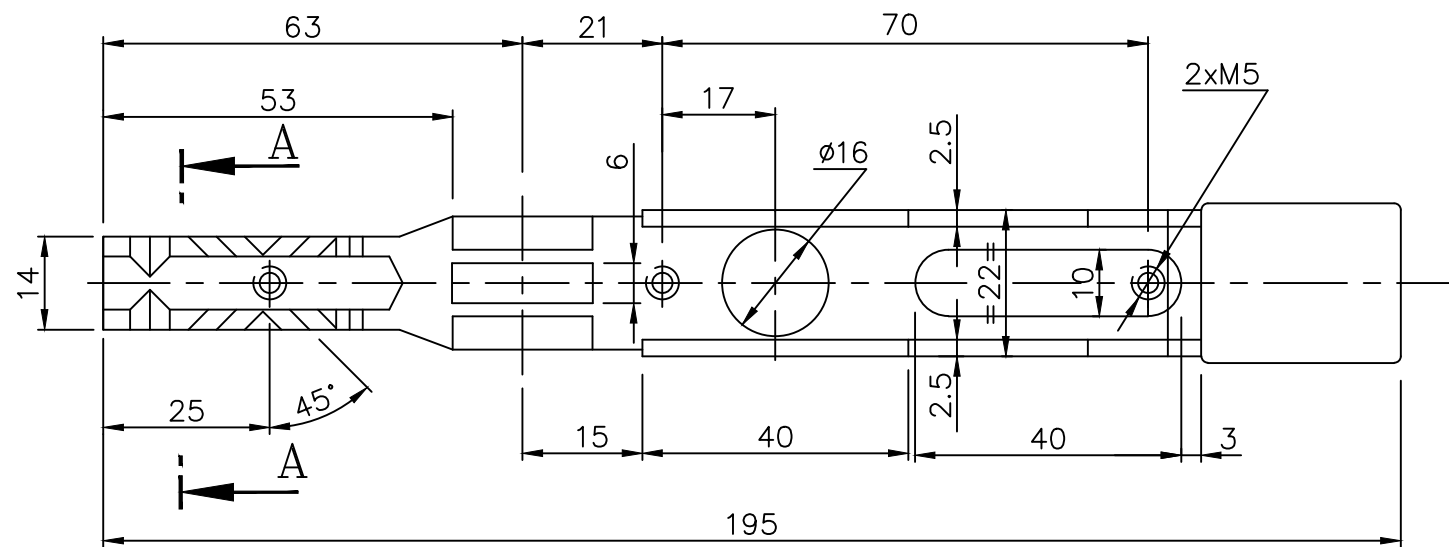
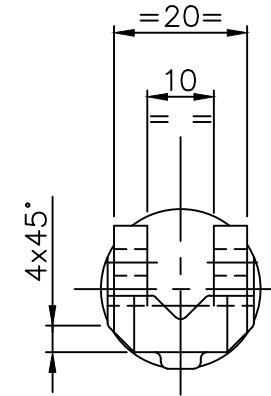
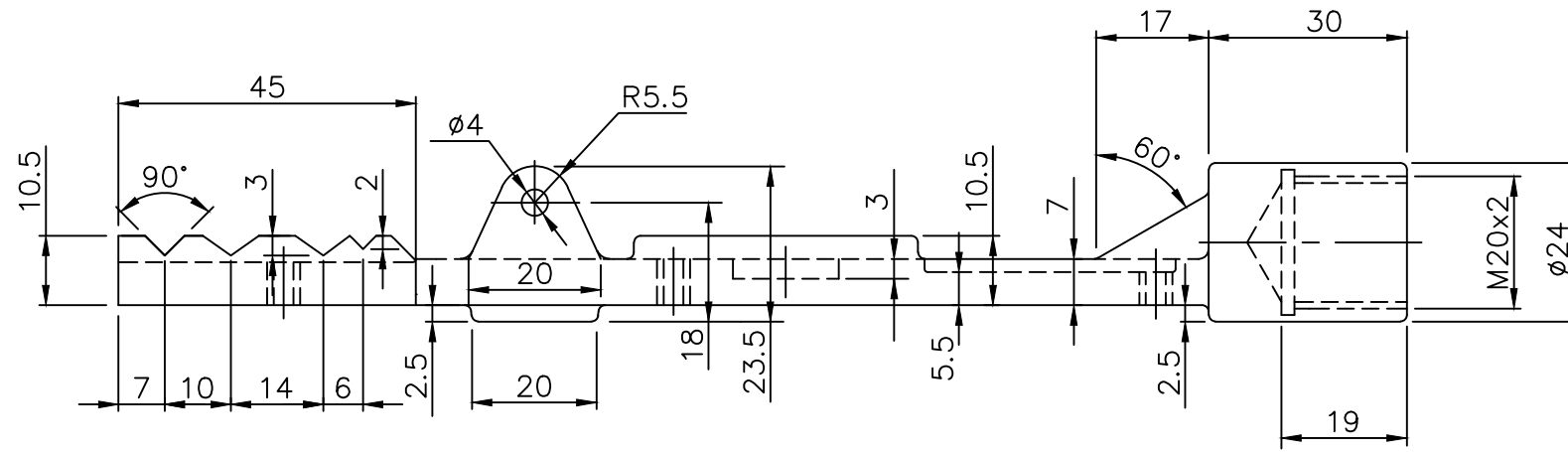

SECTION-AA

MATL. COMPOSITION : NAVAL BRASS
 CU-61-64, Pb-0-2MAX.,
 Sn 1.0 TO 1.5, Fe-0.10MAX.,
 REST-Zn

Ø24x195	FNB	IS: 6912		3-M-10A43-12947	01
No. of Pieces	DESCRIPTION	MATERIAL	STANDARD	NET.WT.IN KGS.	DRAWING No.
	REFERENCE:		ALTERATIONS:	DCN REF	DATE
					SIGN.
SCALE	DRAWN	G.G.R			
	CHECKED	R.RAMAMOORTHY			
	APPROVED	C.S.JAYASHEELAN			
	DATE	20-09-07			
	MACHINE:	WELDING ACCESSORIES		TYPE:	WTC
	TITLE:	BOTTOM JAW (MODIFIED)		DRAWING No:	
		400 AMPS (FULLY INSULATED)		3M10A4312948	
		Sheet No:		No. of Sheets:	

CAUTION: THIS DRAWING IS OUR SOLE PROPERTY AND SHOULD NOT BE USED IN ANY FORM FOR ANY PURPOSE WITHOUT THE WRITTEN PERMISSION OF BHARAT HEAVY ELECTRICALS LIMITED TRICHIRAPPALLI - 620 014.

ALL DIMENSIONS ARE IN MM

3.2/

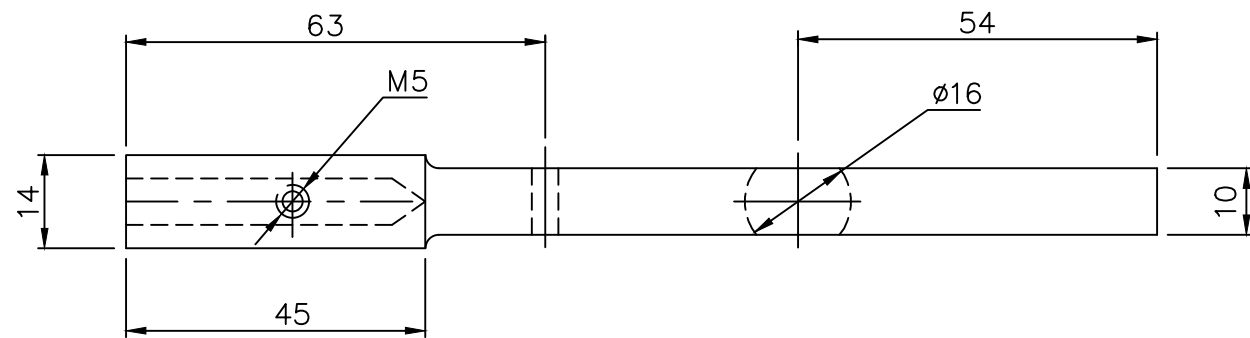
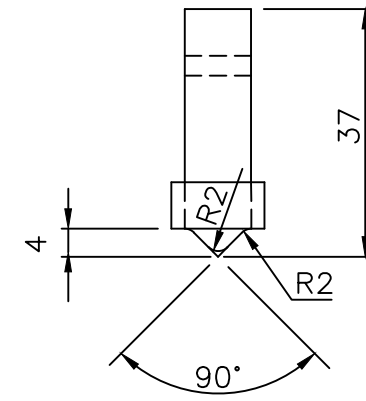
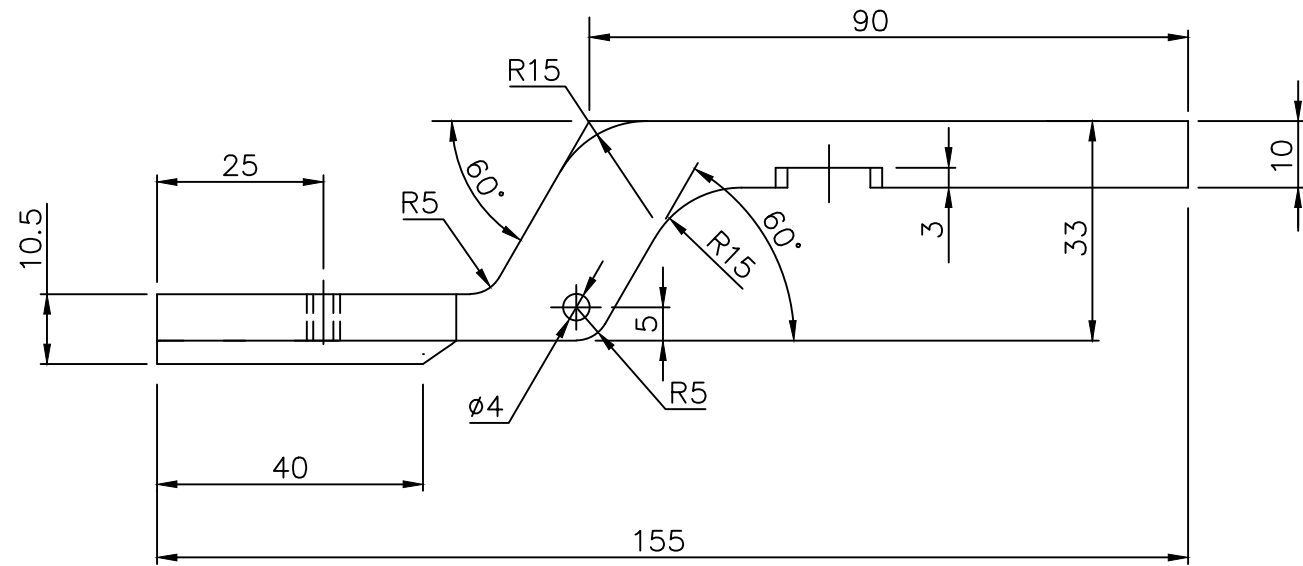

MATL. COMPOSITION : NAVAL BRASS
 CU-61-64, Pb-0-2MAX.,
 Sn 1.0 TO 1.5, Fe-0.10MAX.,
 REST-Zn

No. of Pieces		DESCRIPTION		FNB	IS: 6912	3-M-10A43-12947		02
REFERENCE:		ALTERATIONS:		MATERIAL	STANDARD	NET.WT.IN KGS.	DRAWING No.	ITEM No.
SCALE		DRAWN/TCD		G.G.R		DCN REF		DATE
CHECKED		R.RAMAMOORTHY				SIGN.		INDEX
APPROVED		C.S.JAYASHEELAN						
DATE		20-09-07						
MACHINE: WELDING ACCESSORIES				TYPE: WTC				
TITLE: TOP JAW (MODIFIED)				DRAWING No:				REV.
400 AMPS (FULLY INSULATED)				3M10A4312949				
Sheet No:				No.of Sheets:				

CAUTION: THIS DRAWING IS OUR SOLE PROPERTY AND SHOULD NOT BE USED IN ANY FORM FOR ANY PURPOSE WITHOUT THE WRITTEN PERMISSION OF BHARAT HEAVY ELECTRICALS LIMITED TRICHIRAPPALLI - 620 014.

ALL DIMENSIONS ARE IN MM

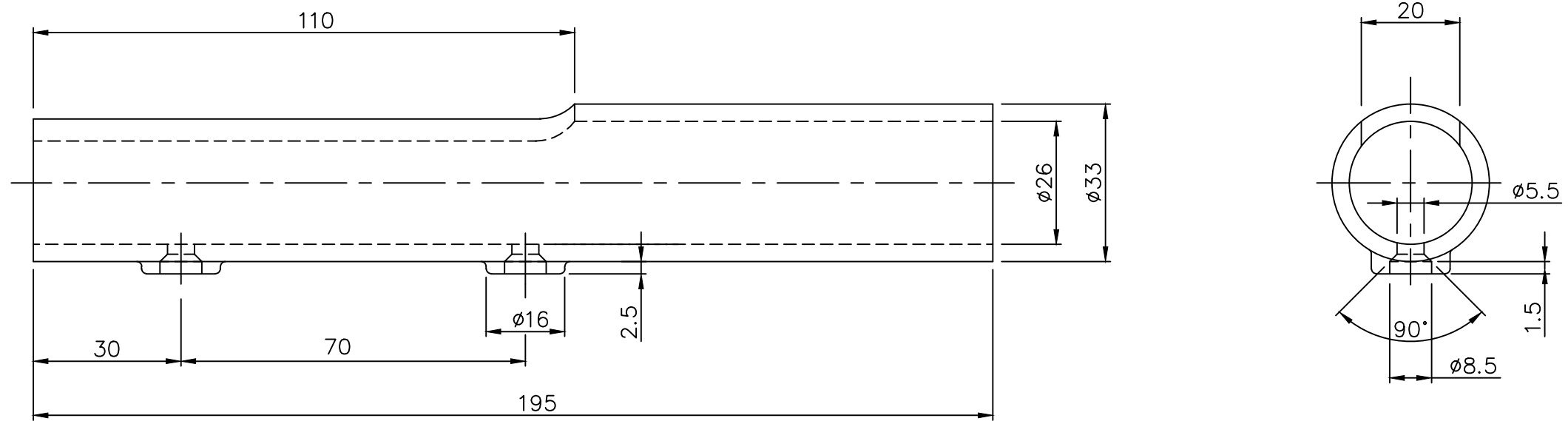

No. of Pieces		DESCRIPTION		MATERIAL	STANDARD	NET.WT.IN KGS.	DRAWING No.	ITEM No.
/		REFERENCE:		ALTERATIONS:		DCN REF	DATE	SIGN.
SCALE	DRAWN	G.G.R						
	CHECKED	R.RAMAMOORTHY						
	APPROVED	C.S.JAYASHEELAN						
	DATE	20-09-07						
MACHINE: WELDING ACCESSORIES				TYPE: WTC				
TITLE: HOLDER COVER(MODIFIED)				DRAWING No:		REV.		
400 AMPS (FULLY INSULATED)				3M10A4312950				
Sheet No:				No.of Sheets:				





THIS DRAWING IS OUR SOLE PROPERTY AND SHOULD NOT BE USED IN ANY FORM FOR ANY PURPOSE WITHOUT THE WRITTEN PERMISSION OF BHARAT HEAVY ELECTRICALS LIMITED TRICHIRAPPALLI - 620 014.

ALL DIMENSIONS ARE IN MM

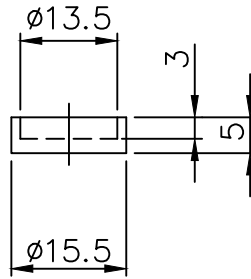
3.2 / 

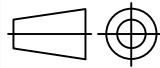

		BAKELITE		3-M-10A43-12943		04							
No. of Pieces		DESCRIPTION		MATERIAL		STANDARD		NET.WT.IN KGS.		DRAWING No.		ITEM No.	
		REFERENCE:		ALTERATIONS:		DCN REF		DATE		SIGN.		INDEX	
SCALE		DRAWN/TCD		G.G.R									
/		CHECKED		R.RAMAMOORTHY									
		APPROVED		C.S.JAYASHEELAN									
		DATE		20/09/07									
		MACHINE: WELDING ACCESSORIES				TYPE: WTC				REV.			
		TITLE:				DRAWING No:							
		SPRING RETAINER (MODIFIED)				4M10A4328059							
		600&400 AMPS (FULLY INSULATED)				Sheet No:				No. of Sheets:			

THIS DRAWING IS OUR SOLE PROPERTY AND SHOULD NOT BE USED IN ANY FORM FOR ANY PURPOSE WITHOUT THE WRITTEN PERMISSION OF BHARAT HEAVY ELECTRICALS LIMITED TRICHIRAPPALLI - 620 014.

ALL DIMENSIONS ARE IN MM

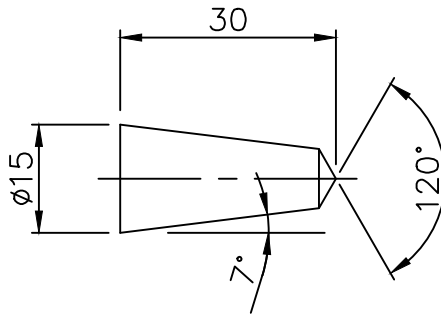

MATL. COMPOSITION : NAVAL BRASS

CU-61-64, Pb-0-2MAX.,

Sn 1.0 TO 1.5, Fe-0.10MAX.,

REST-Zn

No. of Pieces	DESCRIPTION		MATERIAL	STANDARD	NET.WT.IN KGS.	DRAWING No.		ITEM No.
	REFERENCE:		ALTERATIONS:		DCN REF	DATE	SIGN.	INDEX
SCALE	DRAWN/TCD	G.G.R						
/	CHECKED	R.RAMAMOORTHY						
	APPROVED	C.S.JAYASHEELAN						
	DATE	20-09-07						
	MACHINE: WELDING ACCESSORIES			TYPE: WTC				REV.
	TITLE:			DRAWING No:				
	TAPER PLUG (MODIFIED)			4M10A4328060				
600&400 AMPS (FULLY INSULATED)			Sheet No:		No. of Sheets:			

CAUTION: THIS DRAWING IS OUR SOLE PROPERTY AND SHOULD NOT BE USED IN ANY FORM FOR ANY PURPOSE WITHOUT THE WRITTEN PERMISSION OF BHARAT HEAVY ELECTRICALS LIMITED TRICHIRAPPALLI - 620 014.

ALL DIMENSIONS ARE IN MM

3.2 /

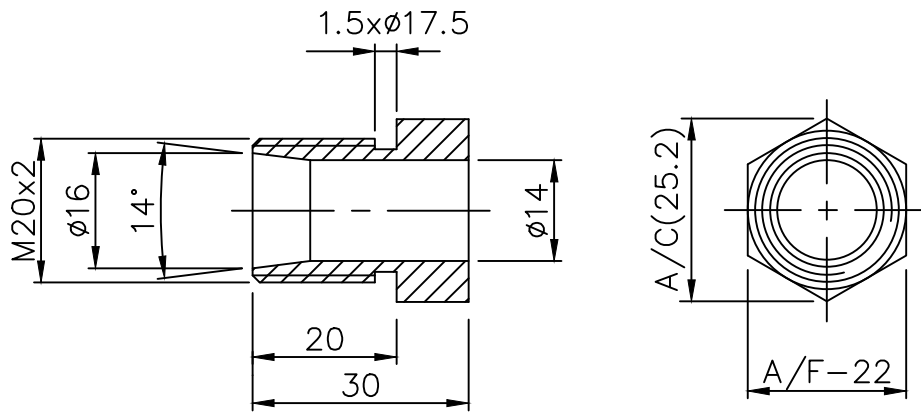

MATL. COMPOSITION : NAVAL BRASS

CU-61-64, Pb-0-2MAX.,

Sn 1.0 TO 1.5, Fe-0.10MAX.,

REST-Zn

X		FNB	IS: 6912		3-M-10A43-12943 3-M-10A43-12947	06
No. of Pieces	DESCRIPTION	MATERIAL	STANDARD	NET.WT.IN KGS.	DRAWING No.	ITEM No.
	REFERENCE:	ALTERATIONS:		DCN REF	DATE	SIGN.
SCALE	DRAWN	G.G.R				
/	CHECKED	R.RAMAMOORTHY				
	APPROVED	C.S.JAYASHEELAN				
	DATE	20-09-07				
MACHINE: WELDING ACCESSORIES			TYPE: WTC			
TITLE:			DRAWING No:			REV.
HEX. NUT M20x2 (MODIFIED)			4M10A4328061			
600&400 AMPS (FULLY INSULATED)			Sheet No:			No. of Sheets:

THIS DRAWING IS OUR SOLE PROPERTY AND SHOULD NOT BE USED IN ANY FORM FOR ANY PURPOSE WITHOUT THE WRITTEN PERMISSION OF BHARAT HEAVY ELECTRICALS LIMITED TRICHIRAPPALLI - 620 014.

ALL DIMENSIONS ARE IN MM

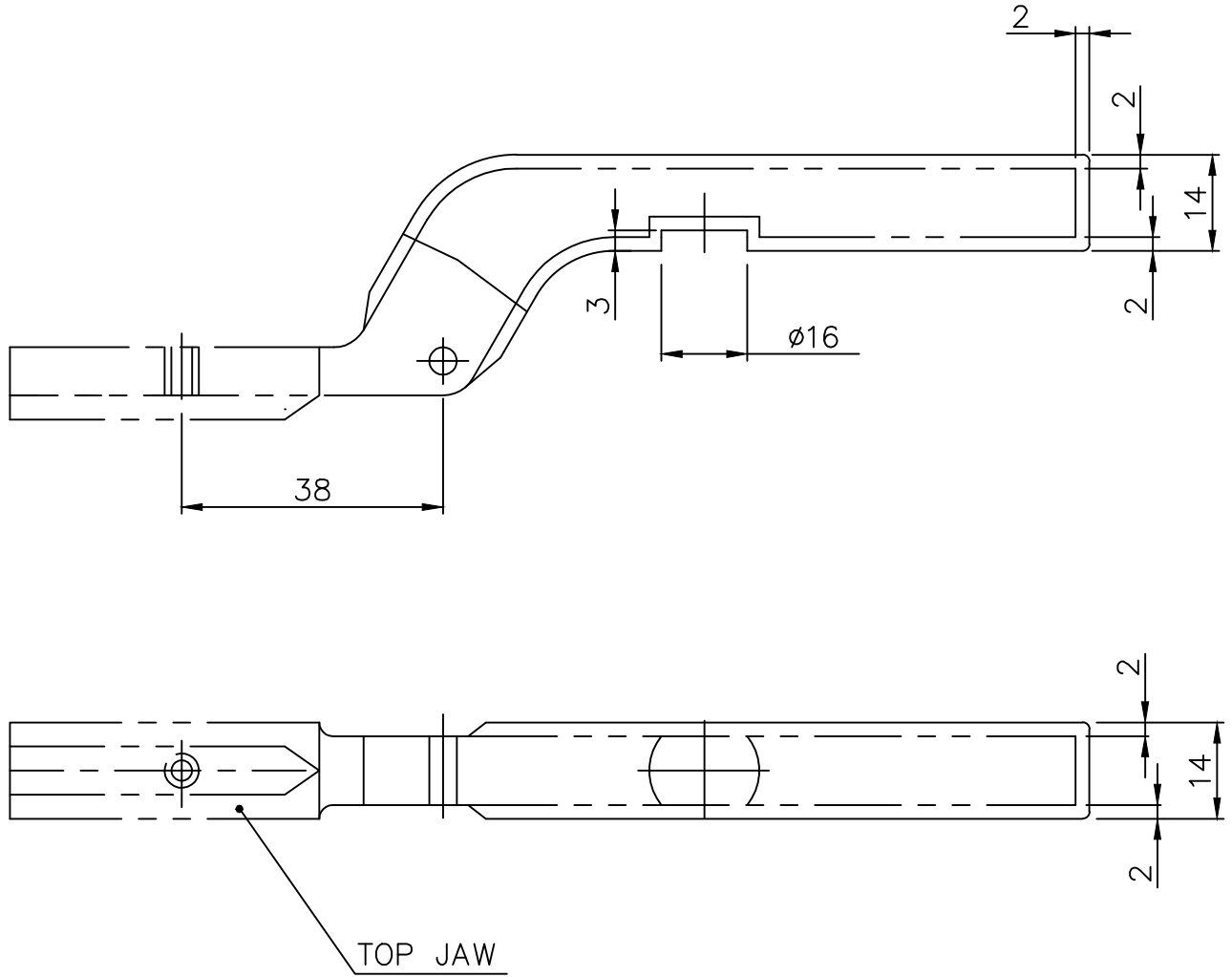

No. of Pieces		DESCRIPTION		MATERIAL	STANDARD	NET.WT.IN KGS.	DRAWING No.		ITEM No.
X				HEAT RESISTANCE UNBREAKABLE FIBRE			3-M-10A43-12943 3-M-10A43-12947		08
REFERENCE:		ALTERATIONS:		DCN REF	DATE	SIGN.	INDEX		
SCALE	DRAWN	G.G.R							
/	CHECKED	R.RAMAMOORTHY							
	APPROVED	C.S.JAYASHEELAN							
	DATE	20-09-07							
MACHINE: WELDING ACCESSORIES				TYPE: WTC					
TITLE:				DRAWING No:					REV.
 JAW COVER (MODIFIED) 600&400 AMPS (FULLY INSULATED)				4M10A4328062					
				Sheet No:		No. of Sheets:			

THIS DRAWING IS OUR SOLE PROPERTY AND SHOULD NOT BE USED IN ANY FORM FOR ANY PURPOSE WITHOUT THE WRITTEN PERMISSION OF BHARAT HEAVY ELECTRICALS LIMITED TRICHIRAPPALLI - 620 014.

CAUTION:

ALL DIMENSIONS ARE IN MM

3.2 // 1.6 //

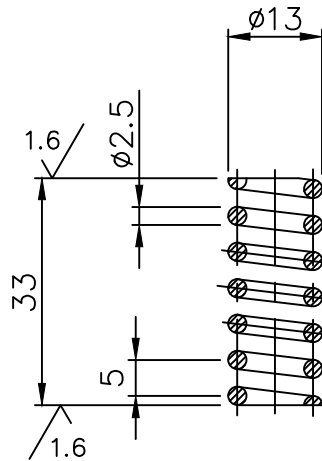

NOTE:

TOTAL No.OF COILS : 8
 EFFECTIVE COILS : 6
 ENDS : CLOSED END COILS SQUARED BY GRINDING
 HARDENED AND TEMPERED

No. of Pieces	DESCRIPTION	MATERIAL	STANDARD	NET.WT.IN KGS.	DRAWING No.	ITEM No.	
	REFERENCE:	ALTERATIONS:	DCN REF	DATE	SIGN.	INDEX	
SCALE	DRAWN	G.G.R					
/	CHECKED	R.RAMAMOORTHY					
	APPROVED	C.S.JAYASHEELAN					
	DATE	20-09-07					
	MACHINE:	WELDING ACCESSORIES		TYPE:	WTC		
	TITLE:	COMP. SPRING (MODIFIED) ID8xOD13x33L 600&400 AMPS (FULLY INSULATED)			DRAWING No:		REV.
					4M10A4328063 Sheet No:	No. of Sheets:	

THIS DRAWING IS OUR SOLE PROPERTY AND SHOULD NOT BE USED IN ANY FORM FOR ANY PURPOSE WITHOUT THE WRITTEN PERMISSION OF BHARAT HEAVY ELECTRICALS LIMITED TRICHIRAPPALLI - 620 014.

ALL DIMENSIONS ARE IN MM

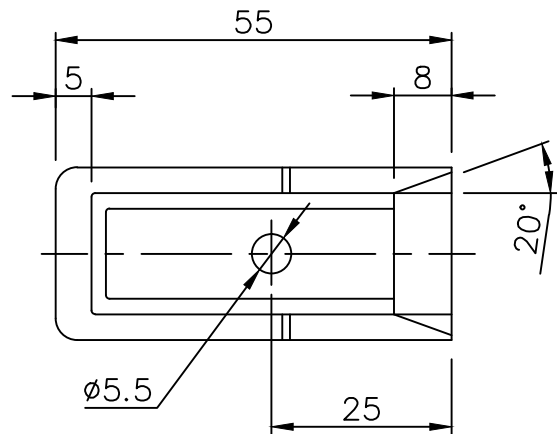
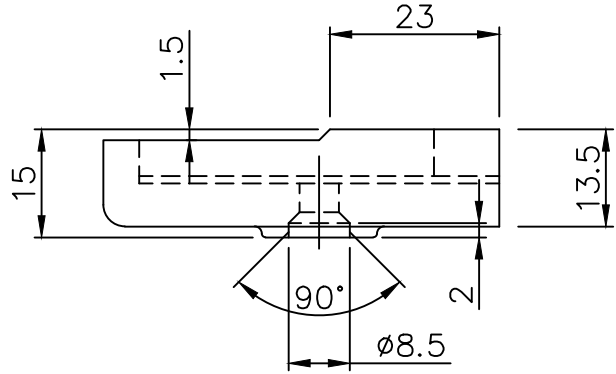
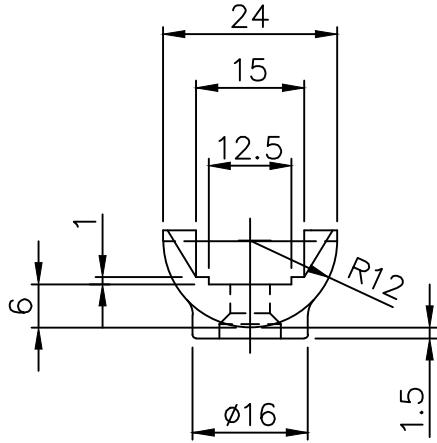

No. of Pieces		DESCRIPTION		MATERIAL	STANDARD	NET.WT.IN KGS.	DRAWING No.	ITEM No.
X				HEAT RESISTANCE UNBREAKABLE FIBRE			3-M-10A43-12947	03
REFERENCE:		ALTERATIONS:		DCN REF	DATE	SIGN.	INDEX	
SCALE		DRAWN	G.G.R					
/		CHECKED	R.RAMAMOORTHY					
		APPROVED	C.S.JAYASHEELAN					
		DATE	20/09/07					
MACHINE: WELDING ACCESSORIES				TYPE: WTC				
TITLE: JAW COVER (MODIFIED) 400 AMPS (FULLY INSULATED)				DRAWING No:				REV.
				4M10A4328064				
				Sheet No:				No. of Sheets:

THIS DRAWING IS OUR SOLE PROPERTY AND SHOULD NOT BE USED IN ANY FORM FOR ANY OTHER PURPOSE WITHOUT THE WRITTEN PERMISSION OF BHAGAT HEAVY ELECTRICALS LTD., TRUSCHERAPALLI - 629 014.

39-607 A

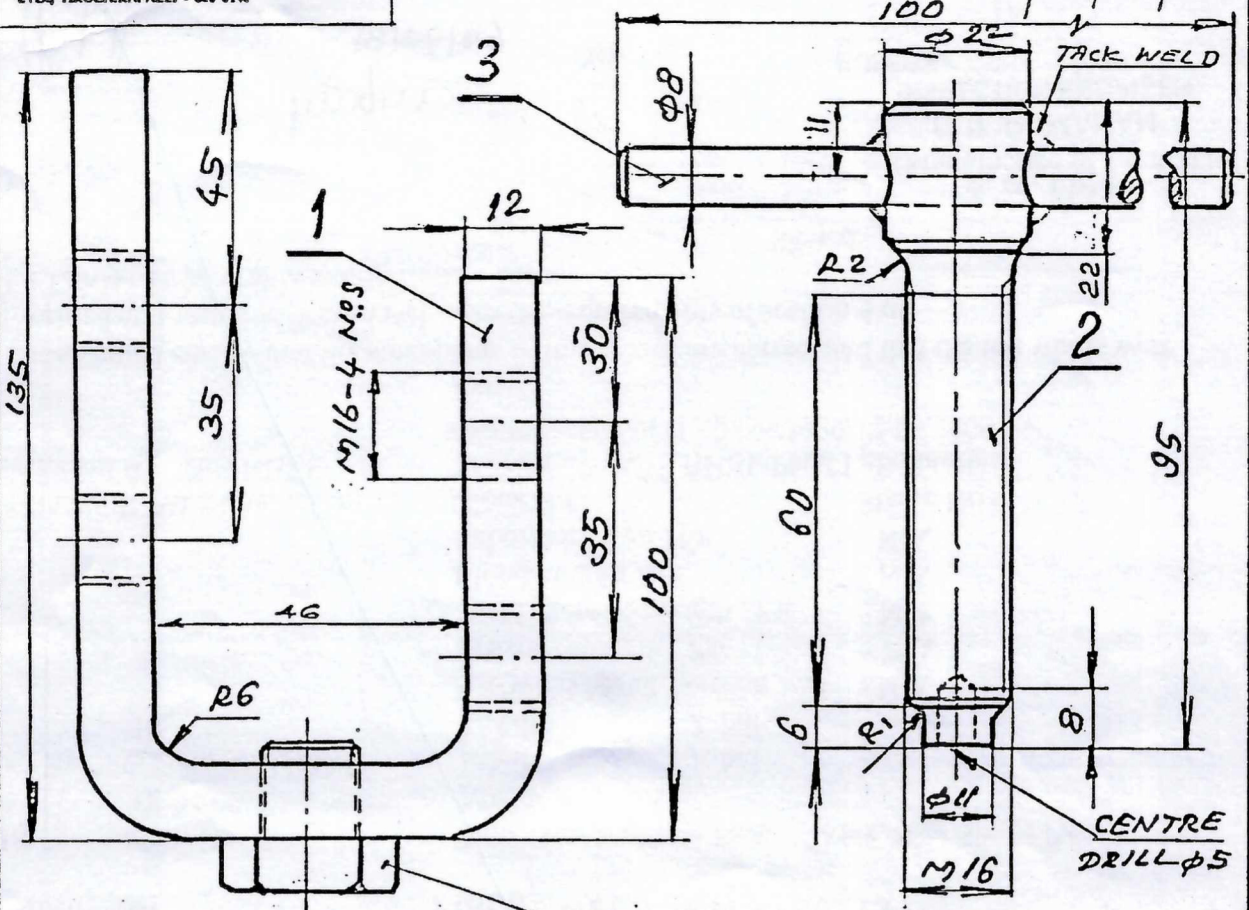

HEX SCREW M16-15 L
MATE C-45 ~~18:7283~~
15:7283

TO BE GALVANISED

1	ROD φ8 x 100	① E-410	15:2062					3
1	ROD φ22 x 95	C-45	15:7283					2
1	PL 12 x 30 x 273	C-45	15:7283					1
NO. OF Pcs	DESCRIPTION	MATERIAL	STD/BPS	Net wt. (kg)	Gross wt. (kg)	DRAWING No.		Item No.
REFERENCE:			ALTERATIONS	EC: 31	CC: 00	DATE	SIGN.	Index
SCALE	DRAWN	15:7283 & E-410 WERE		03.10.15	GAR	01		
1:1	CHECKED	15:2073 & Fe 410 S						
	APPROVED							
	DATE							
MACHINE: WELDING ACCESSORIES			TYPE: GENERAL WTC		Total wt. (kg.)			
TITLE			DRAWING No.		REV.			
CLAMP & HANDLE			4-M-25046		01			
No. of Sheets: 10A43			Sheet No.					

Sl. No.	Pre –Qualification Criteria	Bidder remark
1	<p>Bidder shall be a manufacturer of the Quoted item or an authorized dealer of the same.</p> <p>If the offer is quoted by agent, letter of authorization or agreement duly signed by the manufacturer is required to consider the offer.</p> <p>(Specify: Manufacturer/Authorised Dealer)</p>	
2	<p>Shall confirm to Technical specification as per Tender.</p>	
3	<p>Vendor should give confirmation to BHEL’s Technical Specification.</p> <p>Any deviation from the Specification are to be mentioned in the “Bidder remark Space”.</p> <p>If There is no deviation vendor should indicate “No Deviation”.</p>	

Annexure – A- Additional Terms and Conditions for GeM Enquiry

The terms and condition mentioned in this document are applicable in addition to the GeM General Terms and Conditions. Bidders shall furnish pointwise confirmation/details.

<i>To be filled by bidder</i>		
Description of the Equipment:		
GeM Tender No. & Date		
Name of the firm (Bidder)		:
Address		:
Contact details	<u>Contact person 1</u> Name: Designation: Office Phone: Mobile: e-mail: <u>Contact person 2</u> Name: Designation: Office Phone: Mobile: e-mail:	
Offer/Quotation reference with date		:
Sl. No	Terms and conditions	Vendor's confirmation
1.	Technical: Supply of Welding Accessories - Cable connector sets, electrode holder & assembly, earth clamp and handle shall be as per technical Specifications attached with the enquiry. Bidder shall comply the technical specification as per the enquiry. Any clarifications/deviations to the specification requirements are to be clearly indicated in the above format. Hidden deviations indicated elsewhere in the offer will not be evaluated.	
2.	Pre-qualification requirement: Offer shall be considered only if bidder is meeting Tender Prequalification requirement (Annexure-B). Vendor to comply with Pre-Qualification requirement of the tender and submit along with their technical bid - the credentials and other documents as indicated in the PQR in the format prescribed. Otherwise their offer will get rejected.	
3.	Inspection by BHEL/as per Technical specification(if any).	
4.	Vendor offers will be considered for price bid opening subject to fulfilment of techno commercial suitability.	
5.	Evaluation of tender will be Item Sl no. 1,2 & 3 - Package basis. Item 4 - item wise. Item 5 - item wise. Item 6 - item wise.	
6.	Payment terms: 1. Payment terms for Non MSME Suppliers: Within 90 days after CRAC	

	<p>2. Dealers/Traders (if the quoted items are not manufactured by the supplier) shall be considered as Non-MSME supplier for this tender.</p> <p>3. Payment terms for Micro & Small Enterprises (MSEs): Within 45 days after CRAC. To entitle the above payment terms, the supplier should be manufacturer of the offered item and should upload UDYAM Registration Certificate in proof of MSE.</p> <p>4. Payment terms for Medium Enterprises: Within 60 days after CRAC. To entitle the above payment terms, the supplier should be manufacturer of the offered item and should upload UDYAM Registration Certificate in proof of Medium Enterprises.</p> <p>Payment shall be as per above terms. This a mandatory deemed accepted clause if you are submitted your offer through GeM. Any deviation in this clause anywhere in the offer will be ignored. If a supplier has submitted their offer against this enquiry, it shall be construed that they have accepted the above payment terms relevant to their MSME category without any deviation (Dealers/Traders (if the quoted items are not manufactured by the supplier) shall be considered as Non-MSME supplier for this tender). In case of Auto PRC/CRAC, Payment due date shall be calculated from CRAC date or material acceptance date by BHEL whichever is later.</p>	
7.	<p>Firm Price: The quoted / finalised rates shall be Firm till execution of the supplies. Offer with PVC clause will not be considered.</p>	
8.	<p>Liquidated Damages: LD terms shall be as per GeM General Terms and Conditions. Invoice date/Bill of Lading date/Airway Bill date/Lorry way bill date/e-waybill/Railway Receipt date, whichever is later will be considered for LD calculation.</p>	
9.	<p>Delivery term: The quote shall be on FOR BHEL Trichy destination basis inclusive of Packing, forwarding, Freight also to yours account. Transit Insurance is under Supplier scope.</p>	
10.	<p>Performance Bank Guarantee: Not Applicable</p>	
11.	<p>If Guarantee / Warranty period is applicable as per tender specification, No deviation is permitted and deviated offers are liable for rejection.</p>	
12.	<p>Repair & replacements: Within the guarantee period vendor has to replace / rectify the defective/ damaged items on free of cost within a reasonable time of reporting from our end.</p>	
13.	<p>Kindly Indicate the HSN Code for all items</p>	<p>HSN CODE : _____</p>
14.	<p>Rate quoted in GeM portal should be on FOR destination basis inclusive of all taxes, freight etc. Transit Insurance is under Supplier scope.</p> <p>Please indicate the applicable GST %, P & F and freight cost (in % of material cost), which is included in your quoted rate in GeM portal.</p>	<p>GST in %: _____</p>
15.	<p>Documents are to be submitted along with technical bid (Part-1)</p> <ol style="list-style-type: none"> 01. Covering letter 02. Unpriced offer. 03. Filled up and signed technical specification (GeM Tender 	

	<p>catalogue).</p> <p>04. Filled BHEL Terms and condition sheet (Annexure-A).</p> <p>05. Filled Annexure-B - PQR along with supporting documents.</p> <p>06. Documents required along with offer as per technical specification</p> <p>07. Product Catalogues (if any).</p> <p>08. MSE UDYAM Certificate (if applicable).</p> <p>09. Self-certification for local content declaration as per Make In India Policy</p> <p>Note: All the pages of documents are to be signed and sealed by authorized signatory of the company. Any query during enquiry stage shall be replied within two days failing which offer may be rejected as non-responsive.</p>	
16.	<p>Inspection and testing requirements:</p> <p>Inspection and testing requirements are to be carried out as per the specification and BHEL Technical specifications in the enquiry. All test certificates are to be submitted while supply. If required by BHEL, test certificates to be produced before supply.</p>	
17.	<p>Response to Tenders for Indigenous supplier will be entertained only if the vendor has a valid GST registration Number (GSTIN) which should be clearly mentioned in the offer. If the dealer is exempted from GST registration, a declaration with due supporting documents need to be furnished for considering the offer. Dealers under composition scheme should declare that he is a composition dealer supported by the screen shot taken from GSTN portal. The dealer has to submit necessary documents if there is any change in status under GST.</p>	
18.	<p>PACKING AND MARKING:</p> <p>The supplier shall arrange for securely protecting and packing the stores to avoid loss or damages during transit. (Wherever if applicable).Also, Supplier to comply for packing & marking as per Technical specification.</p>	
19.	<p>Supplier shall mention their GSTIN in all their invoices (incl. credit Notes, Debit Notes) and invoices shall be in the format as specified/prescribed under GST laws. Invoices shall necessarily contain Invoice number (in case of multiple numbering system is being followed for billing like SAP invoice no, commercial invoice no etc., then the Invoice No. which is linked/uploaded in GSTN network shall be clearly indicated), Billed to party (with GSTIN) & Shipped to party details, item description as per PO, Quantity, Rate, Value, applicable taxes with nomenclature (like IGST, SGST, CGST & UTGST) separately, HSN/ SAC Code, Place of Supply etc. Wherever E-Invoice is applicable, the tax invoice/ CN / DN submitted by the vendor must contain the QR code generated in E-Invoice Portal & IRN.</p>	
20.	<p>All invoices shall bear the HSN Code for each item separately (Harmonized System of Nomenclature)/ SAC code (Services Accounting Code).</p>	
21.	<p>Invoices will be processed only upon completion of statutory requirement and further subject to following:</p> <ul style="list-style-type: none"> • Vendor declaring such invoice in their GSTR-1 Return/ IFF • Receipt of Goods or Services and Tax invoice by BHEL. 	
22.	<p>As the continuous uploading of tax invoices in GSTN portal (in GSTR-1/ IFF) is available for all (i.e. both Small & Large) tax payers, all invoices raised on BHEL may be uploaded immediately in GST portal on dispatch of material /rendering of services. The supplier shall ensure availability</p>	

	of Invoice in GSTN portal before submission of invoice to BHEL. Invoices will be admitted by BHEL only if the invoices are available in GSTN portal (in BHEL's GSTR-2A/ GSTR-2B).	
23.	In case of discrepancy in the data uploaded by the supplier in the GSTN portal or in case of any shortages or rejection in the supply, then BHEL will not be able to avail the tax credit and will notify the supplier of the same. Supplier has to rectify the data discrepancy in the GSTN portal or issue credit note or debit note (details also to be uploaded in GSTN portal) for the shortages or rejections in the supplies or additional claims, within the calendar month informed by BHEL.	
24.	In cases where invoice details have been uploaded by the vendor but failed to remit the GST amount to GST Department (Form PMT-08 or Form GST RET-01 to be submitted) within stipulated time, then GST paid on the invoices pertaining to the month for which GST return not filed by the vendor will be recovered from the vendor along with the applicable interest (currently 24% p.a) and all subsequent bills of the vendor will not be processed till filing of the GST return by the vendor	
25.	In case GST credit is denied to BHEL due to non-receipt or delayed receipt of goods and/ or tax invoice or expiry of timeline prescribed in GST law for availing such ITC, or any other reasons not attributable to BHEL, GST amount claimed in the invoice shall be disallowed to the vendor.	
26.	Where any GST liability arising on BHEL under Reverse Charge (RCM), the vendor has to submit the invoices to BHEL well within the timeline prescribed in GST Law, to enable BHEL to discharge the GST liability. If there is a delay in submission of invoice by the vendor resulting in delayed payment of GST by BHEL along with Interest, then such Interest payable or paid shall be recovered from the vendor.	
27.	GST TDS will be deducted as per Section 51 of CGST Act 2017 and in line with Notification 50/2018 –Central Tax dated 13.09.2018. GST TDS certificate will be generated in GSTN portal subsequent to vendor accepting the TDS deduction in the GSTN portal & the vendor can directly download the Certificate from the GSTN Portal.	
28.	<p>As per the provisions of Section 194Q of the Income Tax Act, we BHARAT HEAVY ELECTRICALS LIMITED, HPBP, TRICHY having PAN AAACB4146P, had turnover in the preceding financial year for more than Rs 10 Crores.</p> <p>Hence, we are liable as buyer to deduct tax at source on the payment for invoices issued by Supplier on or after 1st July 2021. Accordingly, discontinue charging TCS u/s 206C(1H) on invoices issued from 1st Jul 2021 onward.</p> <p>We shall deduct the eligible TDS u/s 194Q on the payments for invoices issued on or after 1st Jul 2021. TDS deducted so, shall be deposited to the Income Tax Department, and TDS certificate to this effect. Tax credit of such TDS shall reflect in FORM26AS of the supplier at the end of same quarter in which TDS is deducted.</p> <p>For Suppliers who have not filed Income Tax returns for the last 2 preceding assessment years, TDS deduction at higher rates will be applicable as per Section 206AB and Section 206CCA of Income-tax act.</p>	
29.	GST CREDIT: Suppliers are advised to get registered to GSTN portal. Tenderer under "GST credit" shall be preferred.	

30.	<p>BILL PROCESSING METHOD: Supplier has to ensure the full quantity of material delivery within given PO delivery date to process the bill for payment. In case supplier fails to deliver full quantity within delivery date, bills received after PO delivery date will be processed after final despatch of the total pending supply. Further, bills will be clubbed and forwarded for payment processing as a single bunch.</p>	
31.	<p>MSE /START-UP VENDOR: <i>UDYAM Registration certificate shall be submitted by MSE vendors to avail MSE benefits. Start-up category certificate shall be submitted by start-up companies to avail exemption in Annual Turnover/Past experience if PQC stipulates requirement of Annual Turnover/Past experience.</i></p>	
32.	<p><u>Make in India Policy:</u> Refer the Tender document regarding public procurement policy (Preference to Make in India), Order 2017. "Bidders shall ensure to apply for Make In India preference while quoting through GeM portal. Otherwise offer will not be considered. The local supplier at the time of tender, bidding or solicitation shall be required to provide self-certification that the item offered meets the minimum local content and shall give details of the Location(s) at which the local value addition is made."</p>	
33.	<p>BHEL has the right to test the materials at BHEL works, if required. If supplied materials are found not acceptable, then BHEL will inform to re-supply the materials as per tender specification mentioned in Purchase Order. If any subsequent failure of not meeting the tender specification, RISK PURCHASE is applicable for the full P.O quantity.</p>	
34.	<p>The offers of the bidders who are under suspension and also the offers of the bidders, who engage the services of the banned firms /principal/agents, shall be rejected. The list of banned firms is available on BHEL web site www.bhel.com</p>	
35.	<p><u>Fraud Prevention Policy</u> Bidder along with its associate /collaborators /sub-contractors /sub-vendors / consultants / service providers shall strictly adhere to BHEL Fraud Prevention Policy displayed on BHEL website http://www.bhel.com and shall immediately bring to the notice of BHEL Management about any fraud or suspected fraud as soon as it comes to their notice.</p>	
36.	<p><u>Risk purchase clause:</u> a. In the event of any successful Tenderer's failure to fulfil any of the tender / Contract obligations including supply of whole or any part of the ordered items as per Contract / Agreement, BHEL has the right to terminate the contract and purchase from elsewhere, at the risk and cost of the defaulted supplier, either the whole of the goods or any part which the supplier has failed to deliver or dispatch within the time stipulated in the contract or if the same were not available, the best and nearest available substitute thereof. The supplier shall be liable for the additional expenditure/difference in Cost, if any, including consequential losses which BHEL may sustain by reason of risk purchase in addition to the applicable LD as per the Purchase order/contract. b) The decision of BHEL with regard to the additional expenditure / difference in cost and consequential losses incurred by BHEL shall be final and binding on the supplier.</p>	

	<p>c) The amount recoverable under risk purchase shall be recovered from the defaulted supplier in all or any of the following manners:</p> <ol style="list-style-type: none"> i. from dues available in the form of Bills payable to defaulted supplier, SD, BGs against the same contract. ii. from the dues payable to defaulted supplier against other contracts in the same Region/Unit /any other region/unit iii. In-case recoveries are not possible with any of the above available options, Legal action shall be initiated for recovery against defaulted supplier. iv. GST will be applicable to the amount recoverable under risk purchase 	
37.	<p><u>CONFLICT OF INTEREST:</u></p> <p>A bidder shall not have conflict of interest with other bidders. Such conflict of interest can lead to anti-competitive practices to the detriment of Procuring Entity's interests. The bidder found to have a conflict of interest shall be disqualified. A bidder may be considered to have a conflict of interest with one or more parties in this bidding process, if:</p> <ol style="list-style-type: none"> a) they have controlling partner (s) in common; or b) they receive or have received any direct or indirect subsidy financial stake from any of them; or c) they have the same legal representative/agent for purposes of this bid; or d) they have relationship with each other, directly or through common third parties, <u>that puts them in a position to have access to information about or influence on the bid of another Bidder;</u> or e) Bidder participates in more than one bid in this bidding process, Participation by a Bidder in more than one Bid will result in the disqualification of all bids in which the parties are involved. <u>However, this does not limit the inclusion of the components/ sub-assembly/ Assemblies from one bidding manufacturer in more than one bid;</u> or f) In cases of agents quoting in offshore procurements, on behalf of their principal manufacturers, one agent cannot represent two manufacturers or quote on their behalf in a particular tender enquiry. One manufacturer can also authorise only one agent/dealer. There can be only one bid from the following: <ol style="list-style-type: none"> 1. The principal manufacturer directly or through one Indian agent on his behalf; and 2. Indian/foreign agent on behalf of only one principal; <p style="text-align: center;">or</p> g) A Bidder or any of its affiliates participated as a consultant in the preparation of the design or technical specifications of the contract that is the subject of the Bid, or h) In case of a holding company having more than one independently manufacturing units, or more than one unit having common business ownership/Management, only one unit shall quote. Similar restrictions would apply to closely related sister companies. Bidder must proactively declare such sister/common business/ management units in same/similar line of business. 	
38.	<p><u>Set off :</u> BHEL shall have the right to recover any money which in the sole opinion of BHEL is due from the supplier from any money due to the supplier under this Contract or any other contract or from the Security Deposit/BG furnished by the supplier under this Contract or</p>	

	any other contract.	
39.	<u>Cartel Formation:</u> The Bidder declares that they will not enter into any illegal or undisclosed agreement or understanding, whether formal or informal with other Bidder(s). This applies in particular to prices, specifications, certifications, subsidiary contracts, submission or non-submission of bids or any other actions to restrict competitiveness or to introduce cartelization in the bidding process. In case, the Bidder is found having indulged in above activities, suitable action shall be taken by BHEL as per extant policies/ guidelines.	
40.	The following documents are to be sent along with consignment to store: One Duplicate for Transporter copy of tax invoice + one extra copy of tax invoice + Delivery challan + LR COPY+E-Way bill+ Test Certificates (if applicable).	
41.	Seller Tax invoice, LR copy, E-Way bill, Courier docket etc. are to be uploaded in GeM portal while updating dispatch details in GeM portal	
42.	Seller Tax invoices (Original for Recipient + Duplicate for Transporter) either in Original hard copies or Digitally Signed Soft copies along with copy of LR + E-Way bill are to be sent to the buyer	
43.	Any change in applicable rates of Tax or any other statutory levies (Direct / Indirect) or any new introduction of any levy by means of statute and its corresponding liability for the deliveries beyond the agreed delivery date for reasons not attributable to BHEL will be to vendors account. BHEL will not reimburse the same and any subsequent claim in this respect will be summarily rejected.	
	<p><u>Note:</u></p> <ol style="list-style-type: none"> 1. In the event of our customer order covering this tender being cancelled /placed on hold / otherwise modified, BHEL would be constrained to accordingly cancel / hold / modify the tender at any stage of execution. 2. BHEL may negotiate the L1 rate, if not meeting our budget / estimated cost. BHEL may re-float the tender opened, if L1 price is not acceptable to BHEL. 3. BHEL reserves its right to reject an offer due to unsatisfactory past performance by the respective Vendor in the execution of any contract to any BHEL project / Unit. 4. Any other commercial terms indicated by the vendor in their offer elsewhere will be ignored. BHEL will proceed with tender evaluation as per Annexure-A and GeM general terms and conditions only. 	

/ On Bidder's office letter pad /

Self-Declaration

Enquiry No.	
Enquiry Date	

In line with Government public procurement order Number P-45021/2/2017-B.E-II dated 15.06.2017, and further modified order dt. 28.05.2018, 29.05.2019 & order 04.06.2020 issued by DPIIT

I / We hereby declare that I / We are a "Local Supplier" meeting the requirement of minimum local content (..... %) defined in the above government notification for the goods against above mentioned enquiry Number.

Details of location at which local value addition will be made is as follows:

Door No.	
Street / Address 1	
Street / Address 2	
District	
State	
Country	
PIN Code	

We also understand that the false declarations will be in breach of the code of Integrity under rule 175(1)(i)(h) of the General financial rules for which a bidder or its successors can be debarred for up to two years as per Rule 151(iii) of the General Financial Rules along with such other actions as may be permissible under law.

For Company Name:

Seal:

Signature:

Date:

Place:

Note:

" Local Content "means the amount of value added in India which shall ,unless otherwise prescribed by the Nodal Ministry, be the total value of the item procured(excluding net domestic indirect taxes) minus the value of imported content in the item(including all customs duties) as a proportion of the total value, in percent. "Local Supplier "means a supplier or service provider whose product or service offered for procurement meets the minimum local content.

The above declaration shall be submitted mandatorily along with the offer in company letter head with seal & signature.

(Please fill all the yellow color field)